

SECTION **DMS**

DRIVE MODE SYSTEM

A
B
C
D
E
F
G
H
I
J
K
L
M
N
DMS
P

CONTENTS

SPORT MODE	
PRECAUTION	3
PRECAUTIONS	3
Precaution for Supplemental Restraint System (SRS) "AIR BAG" and "SEAT BELT PRE-TENSIONER"	3
Precaution for Work	3
PREPARATION	4
PREPARATION	4
Special Service Tool	4
SYSTEM DESCRIPTION	5
COMPONENT PARTS	5
Component Parts Location	5
SPORT Mode Switch	6
SPORT Mode Indicator Lamp	6
SYSTEM	8
SPORT MODE CONTROL	8
SPORT MODE CONTROL : System Description.....	8
ECU DIAGNOSIS INFORMATION	9
SPORT MODE	9
List of ECU Reference	9
WIRING DIAGRAM	10
SPORT MODE SYSTEM	10
Wiring Diagram	10
BASIC INSPECTION	14
DIAGNOSIS AND REPAIR WORK FLOW	14
Work Flow	14
DTC/CIRCUIT DIAGNOSIS	15
SPORT MODE SWITCH	15
Component Function Check	15
Diagnosis Procedure	15
Component Inspection	16
SYMPTOM DIAGNOSIS	17
THE SPORT MODE INDICATOR LAMP DOES NOT TURN ON	17
Description	17
Diagnosis Procedure	17
REMOVAL AND INSTALLATION	18
SPORT MODE SWITCH	18
Removal and Installation	18
ECO MODE	
PRECAUTION	19
PRECAUTIONS	19
Precaution for Supplemental Restraint System (SRS) "AIR BAG" and "SEAT BELT PRE-TENSIONER"	19
Precaution for Work	19
PREPARATION	20
PREPARATION	20
Special Service Tool	20
SYSTEM DESCRIPTION	21
COMPONENT PARTS	21
Component Parts Location	21
ECO Mode Switch	22
ECO Mode Indicator Lamp	22
SYSTEM	23
ECO MODE CONTROL	23
ECO MODE CONTROL : System Description	23

ECU DIAGNOSIS INFORMATION	24	ECO MODE SWITCH	30
ECO MODE	24	Component Function Check	30
List of ECU Reference	24	Diagnosis Procedure	30
WIRING DIAGRAM	25	Component Inspection	32
ECO MODE SYSTEM	25	SYMPTOM DIAGNOSIS	33
Wiring Diagram	25	THE ECO MODE INDICATOR LAMP DOES	
BASIC INSPECTION	29	NOT TURN ON	33
DIAGNOSIS AND REPAIR WORK FLOW	29	Description	33
Work Flow	29	Diagnosis Procedure	33
DTC/CIRCUIT DIAGNOSIS	30	REMOVAL AND INSTALLATION	34
		ECO MODE SWITCH	34
		Removal and Installation	34

PRECAUTION

PRECAUTIONS

Precaution for Supplemental Restraint System (SRS) "AIR BAG" and "SEAT BELT PRE-TENSIONER"

INFOID:000000011279910

The Supplemental Restraint System such as "AIR BAG" and "SEAT BELT PRE-TENSIONER", used along with a front seat belt, helps to reduce the risk or severity of injury to the driver and front passenger for certain types of collision. Information necessary to service the system safely is included in the SR and SB section of this Service Manual.

WARNING:

- To avoid rendering the SRS inoperative, which could increase the risk of personal injury or death in the event of a collision which would result in air bag inflation, all maintenance must be performed by an authorized NISSAN/INFINITI dealer.
- Improper maintenance, including incorrect removal and installation of the SRS, can lead to personal injury caused by unintentional activation of the system. For removal of Spiral Cable and Air Bag Module, see the SR section.
- Do not use electrical test equipment on any circuit related to the SRS unless instructed to in this Service Manual. SRS wiring harnesses can be identified by yellow and/or orange harnesses or harness connectors.

PRECAUTIONS WHEN USING POWER TOOLS (AIR OR ELECTRIC) AND HAMMERS

WARNING:

- When working near the Airbag Diagnosis Sensor Unit or other Airbag System sensors with the Ignition ON or engine running, DO NOT use air or electric power tools or strike near the sensor(s) with a hammer. Heavy vibration could activate the sensor(s) and deploy the air bag(s), possibly causing serious injury.
- When using air or electric power tools or hammers, always switch the Ignition OFF, disconnect the battery and wait at least three minutes before performing any service.

Precaution for Work

INFOID:000000011376588

- When removing or disassembling each component, be careful not to damage or deform it. If a component may be subject to interference, be sure to protect it with a shop cloth.
- When removing (disengaging) components with a screwdriver or similar tool, be sure to wrap the component with a shop cloth or vinyl tape to protect it.
- Protect the removed parts with a shop cloth and prevent them from being dropped.
- Replace a deformed or damaged clip.
- If a part is specified as a non-reusable part, always replace it with a new one.
- Be sure to tighten bolts and nuts securely to the specified torque.
- After installation is complete, be sure to check that each part works properly.
- Follow the steps below to clean components:
 - Water soluble dirt:
 - Dip a soft cloth into lukewarm water, wring the water out of the cloth and wipe the dirty area.
 - Then rub with a soft, dry cloth.
 - Oily dirt:
 - Dip a soft cloth into lukewarm water with mild detergent (concentration: within 2 to 3%) and wipe the dirty area.
 - Then dip a cloth into fresh water, wring the water out of the cloth and wipe the detergent off.
 - Then rub with a soft, dry cloth.
 - Do not use organic solvent such as thinner, benzene, alcohol or gasoline.
 - For genuine leather seats, use a genuine leather seat cleaner.

A
B
C
D
E
F
G
H
I
J
K
L
M
N
P

DMS

PREPARATION

PREPARATION

Special Service Tool

INFOID:000000011376589

The actual shape of the tools may differ from those illustrated here.

Tool number (TechMate No.) Tool name	Description
— (J-46534) Trim Tool Set	Removing trim components

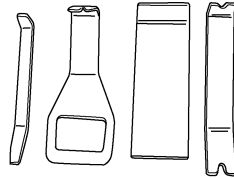

AWJIA04832Z

SYSTEM DESCRIPTION

COMPONENT PARTS

Component Parts Location

INFOID:0000000011279911

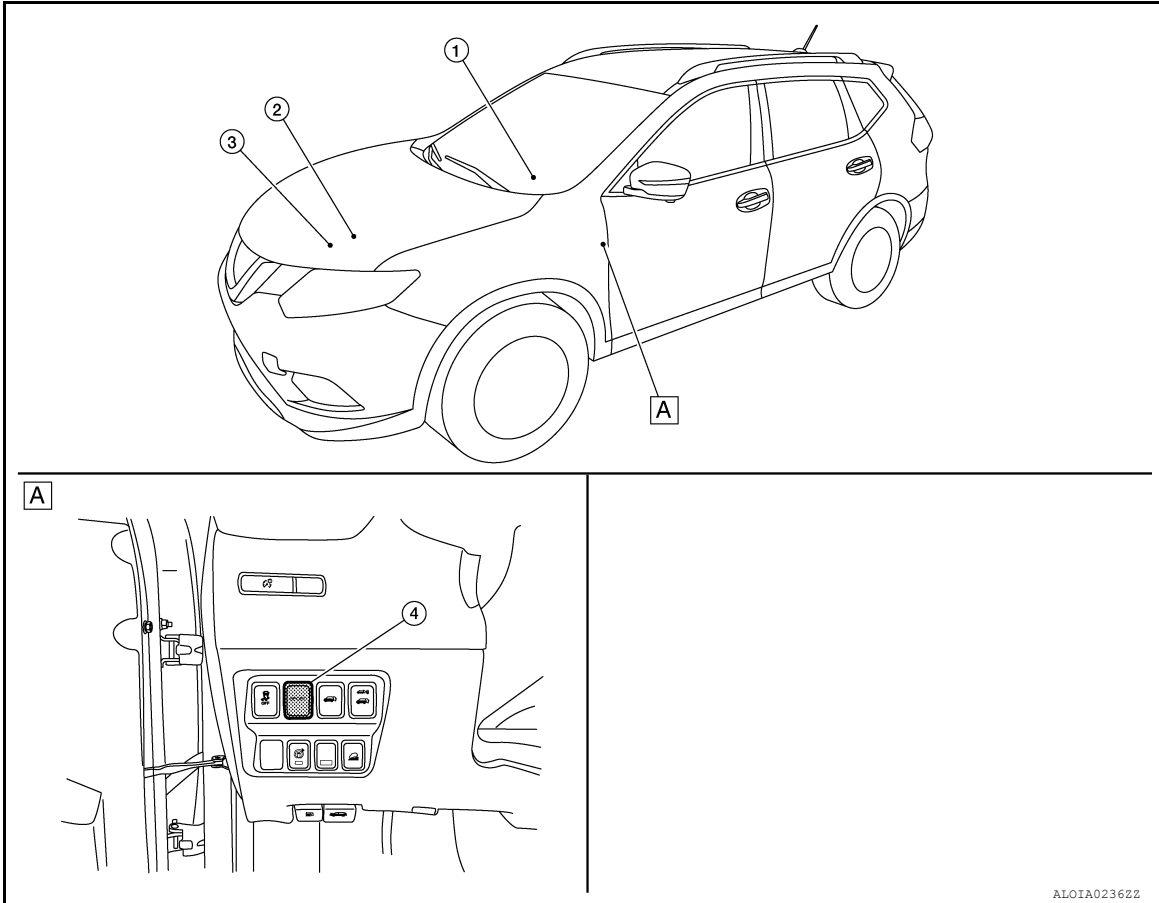

A Instrument lower panel LH

No.	Component	Function
①	Combination meter	<ul style="list-style-type: none"> The combination meter transmits the following signal via CAN communications to the TCM. <ul style="list-style-type: none"> - SPORT mode switch signal The combination meter receives the following signal via CAN communications from the ECM. <ul style="list-style-type: none"> - SPORT mode indicator signal Refer to MWI-6, "METER SYSTEM : Component Parts Location" for detailed installation location.
②	TCM	<ul style="list-style-type: none"> The TCM receives the following signal via CAN communications from the combination meter. <ul style="list-style-type: none"> - SPORT mode switch signal The TCM transmits the following signal via CAN communications to the ECM. <ul style="list-style-type: none"> - SPORT mode signal Refer to TM-12, "CVT CONTROL SYSTEM : Component Parts Location" for detailed installation location.

A
B
C
D
E
F
G
H
I
J
K
L
M
N
DMS
P

COMPONENT PARTS

< SYSTEM DESCRIPTION >

[SPORT MODE]

No.	Component	Function
③	ECM	<ul style="list-style-type: none"> The ECM receives the following signal via CAN communications from the TCM. <ul style="list-style-type: none"> - SPORT mode signal The ECM transmits the following signal via CAN communications to the combination meter. <ul style="list-style-type: none"> - SPORT mode indicator signal Refer to EC-14. "Component Parts Location" for detailed installation location.
④	SPORT mode switch	Refer to DMS-6. "SPORT Mode Switch" .

SPORT Mode Switch

INFOID:000000011279912

- The SPORT mode switch is installed to the instrument lower finisher.
- When the SPORT mode indicator lamp on the combination meter is OFF and the SPORT mode switch is pressed, the SPORT mode is active and the SPORT mode indicator lamp is ON.
- When the SPORT mode indicator lamp on the combination meter is ON and the SPORT mode switch is pressed, the SPORT mode is cancelled and the SPORT mode indicator lamp is OFF.

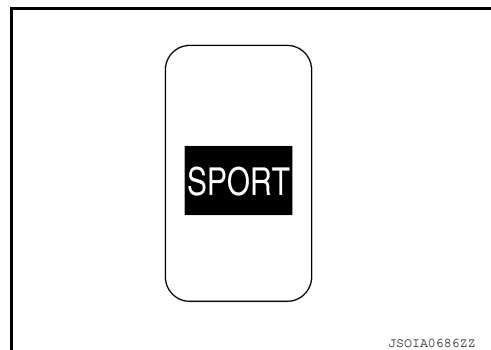

SPORT Mode Indicator Lamp

INFOID:000000011279913

DESIGN/PURPOSE

The SPORT mode indicator lamp inform the driver that the vehicle is in SPORT mode.

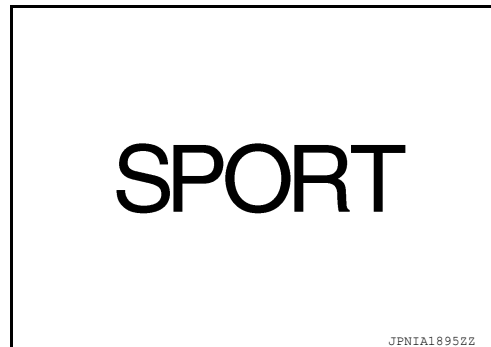

BULB CHECK

Not applicable

SYSTEM DIAGRAM

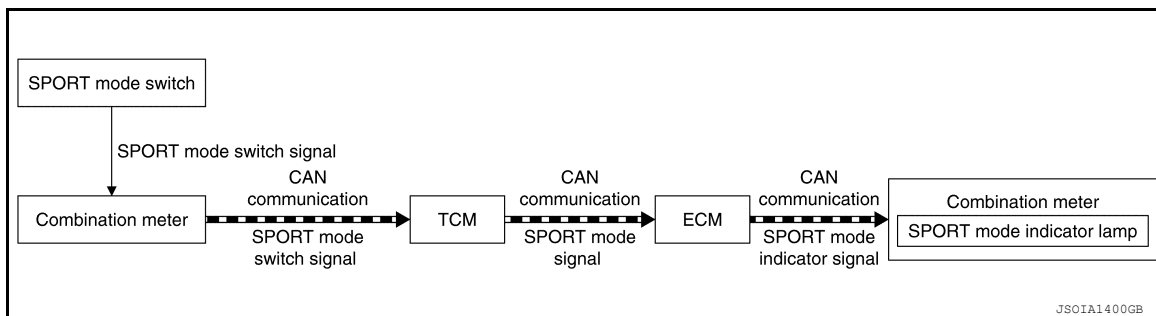

SIGNAL PATH

- TCM receives SPORT mode switch signal (ON/OFF) from combination meter via CAN communication. Based on the signal, TCM transmits SPORT mode signal to ECM via CAN communication.
- ECM transmits SPORT mode indicator signal to combination meter via CAN communication. Based on the signal, combination meter illuminates SPORT mode indicator lamp.

LIGHTING CONDITION

When all of the following conditions are satisfied.

COMPONENT PARTS

< SYSTEM DESCRIPTION >

[SPORT MODE]

- Ignition switch: ON
- The SPORT mode switch is pressed when the SPORT mode indicator lamp is OFF

A

SHUTOFF CONDITION

When any of the condition listed below is satisfied.

- Ignition switch: Other than ON
- The SPORT mode switch is pressed when the SPORT mode indicator lamp is ON.

B

C

D

E

F

G

H

I

J

K

L

M

N

DMS

P

SYSTEM

SPORT MODE CONTROL

SPORT MODE CONTROL : System Description

INFOID:0000000011279914

SYSTEM DIAGRAM

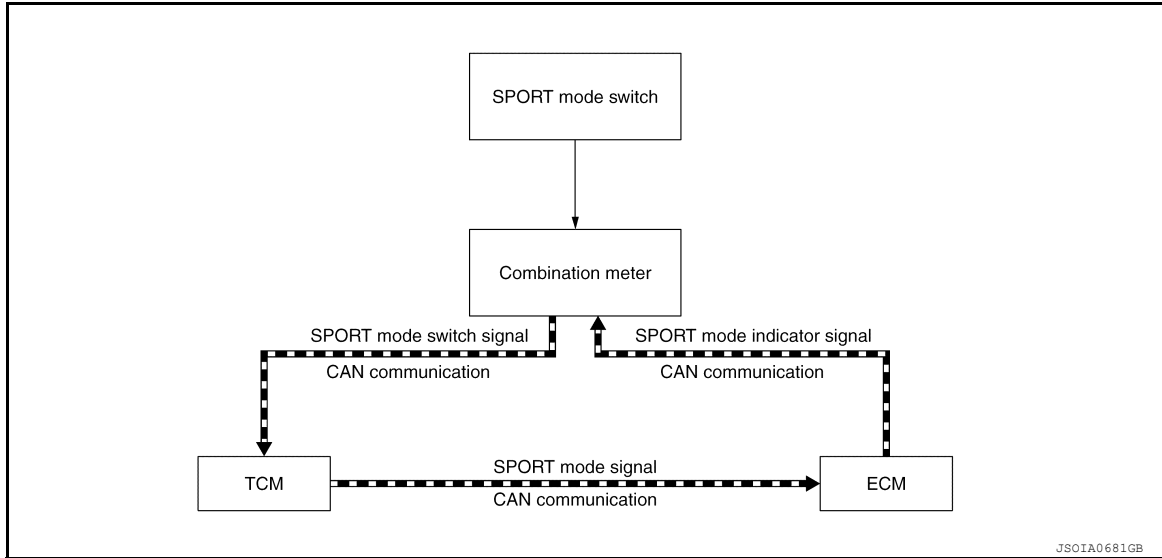

SYSTEM DISCRIPTION

- TCM receives SPORT mode switch signal (ON/OFF) from combination meter via CAN communication. TCM transmit SPORT mode signal to ECM via CAN communication according to the signal.
- ECM transmits SPORT mode indicator signal to combination meter via CAN communication. Combination meter illuminates SPORT mode indicator lamp according to the signal.

Each ECU Control

- For TCM control, refer to [TM-41. "SPORT MODE CONTROL : System Description"](#).
- For ECM control, refer to [EC-56. "SPORT MODE CONTROL : System Description"](#).

ECU DIAGNOSIS INFORMATION

SPORT MODE

List of ECU Reference

INFOID:0000000011279915

ECU	Reference
TCM	TM-52, "Reference Value"
	TM-58, "Fail-safe"
	TM-62, "DTC Inspection Priority Chart"
	TM-63, "DTC Index"
ECM	EC-80, "Reference Value"
	EC-92, "Fail Safe"
	EC-95, "DTC Inspection Priority Chart"
	EC-96, "DTC Index"
Combination meter	MWI-25, "Reference Value"
	MWI-30, "Fail-safe"
	MWI-31, "DTC Index"

A
B
C
D
E
F
G
H
I
J
K
L
M
N
P

DMS

SPORT MODE SYSTEM

< WIRING DIAGRAM >

[SPORT MODE]

WIRING DIAGRAM

SPORT MODE SYSTEM

Wiring Diagram

INFOID:0000000011279916

SPORT MODE SYSTEM

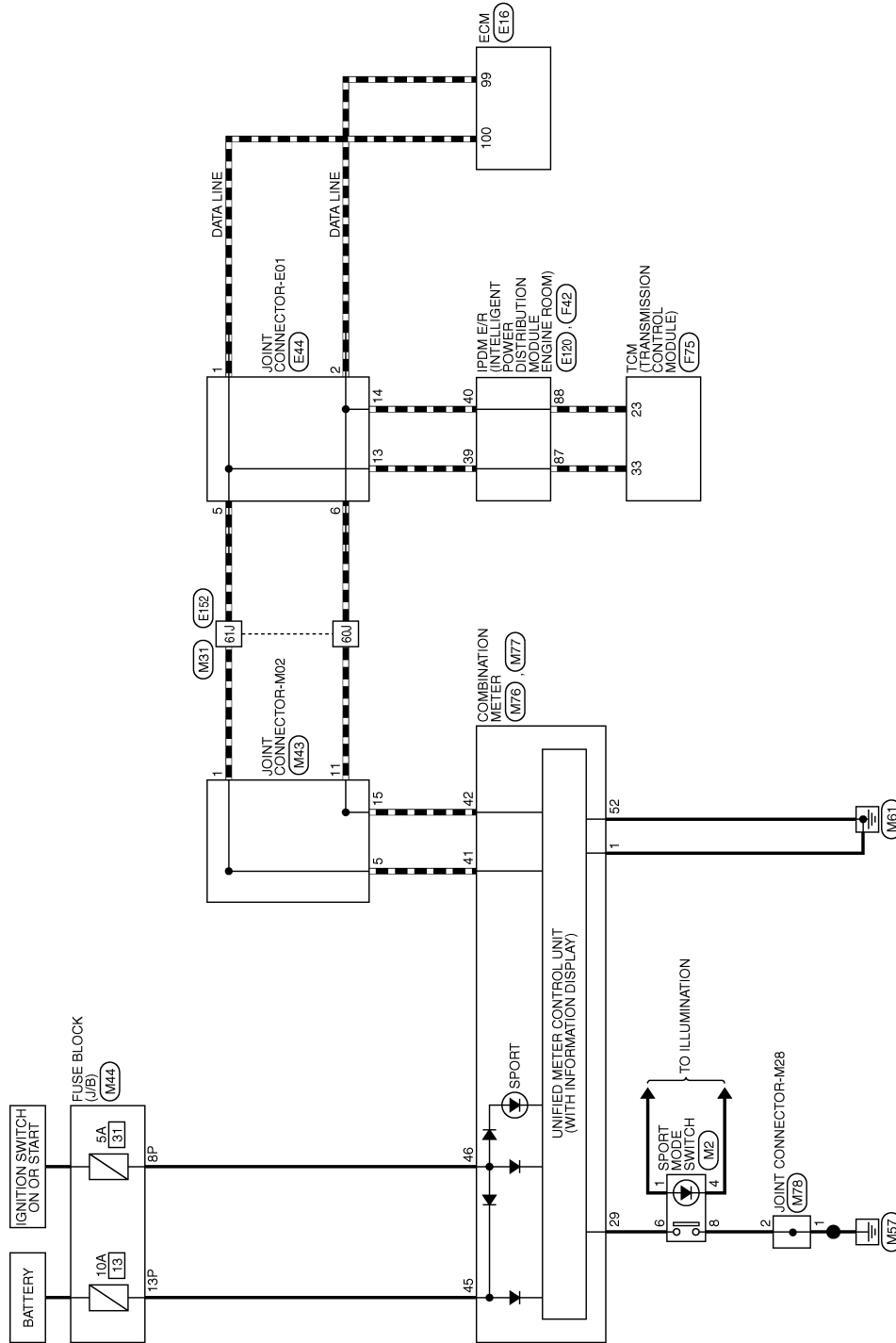

AAQWA0050GB

SPORT MODE SYSTEM

< WIRING DIAGRAM >

[SPORT MODE]

SPORT MODE SYSTEM CONNECTORS

Connector No.	M2
Connector Name	SPORT MODE SWITCH
Connector Color	BLUE

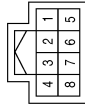

Terminal No.	Color of Wire	Signal Name
1	G	-
4	GR	-
6	R	-
8	GR	-

Connector No.	M31
Connector Name	WIRE TO WIRE
Connector Color	WHITE

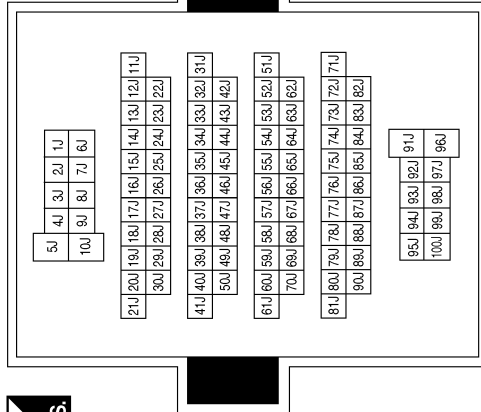

Terminal No.	Color of Wire	Signal Name
60J	P	-
61J	L	-

Connector No.	M43
Connector Name	JOINT CONNECTOR-M02
Connector Color	BLUE

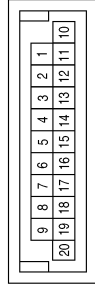

Terminal No.	Color of Wire	Signal Name
1	L	-
5	L	-
11	P	-
15	P	-

Connector No.	M44
Connector Name	FUSE BLOCK (J/B)
Connector Color	WHITE



Terminal No.	Color of Wire	Signal Name
8P	LA/BR	-
13P	LA/G	-

Connector No.	M76
Connector Name	COMBINATION METER
Connector Color	WHITE



Terminal No.	Color of Wire	Signal Name
1	B	GND
29	R	SPORT MODE SW

A
B
C
D
E
F
G
H
I
J
K
L
M
N
P



SPORT MODE SYSTEM

< WIRING DIAGRAM >

[SPORT MODE]

Connector No.	E16
Connector Name	ECM
Connector Color	BLACK

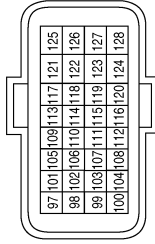

Terminal No.	Color of Wire	Signal Name
99	P	CAN-L
100	L	CAN-H

Connector No.	M78
Connector Name	JOINT CONNECTOR-M28
Connector Color	WHITE



Terminal No.	Color of Wire	Signal Name
1	GR	-
2	GR	-

Connector No.	M77
Connector Name	COMBINATION METER
Connector Color	WHITE

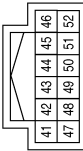

Terminal No.	Color of Wire	Signal Name
41	L	CAN-H
42	P	CAN-L
45	LA/G	BAT
46	LA/BR	IGN
52	B	G1

Connector No.	E120
Connector Name	IPDM E/R (INTELLIGENT POWER DISTRIBUTION MODULE ENGINE ROOM)
Connector Color	GRAY

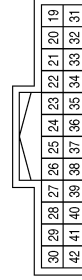

Terminal No.	Color of Wire	Signal Name
39	L	CAN-H
40	P	CAN-L

Terminal No.	Color of Wire	Signal Name
1	L	-
2	P	-
5	L	-
6	P	-
13	L	-
14	P	-

Connector No.	E44
Connector Name	JOINT CONNECTOR-E01
Connector Color	WHITE

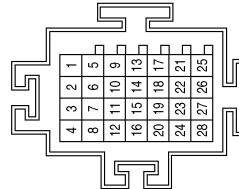

AA01A0190GB

SPORT MODE SYSTEM

< WIRING DIAGRAM >

[SPORT MODE]

Connector No.	F42
Connector Name	IPDM E/R (INTELLIGENT POWER DISTRIBUTION MODULE ENGINE ROOM)
Connector Color	BLACK

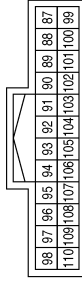

Terminal No.	Color of Wire	Signal Name
87	L	CAN-H
88	P	CAN-L

Terminal No.	Color of Wire	Signal Name
60J	P	-
61J	L	-

Connector No.	E152
Connector Name	WIRE TO WIRE
Connector Color	WHITE

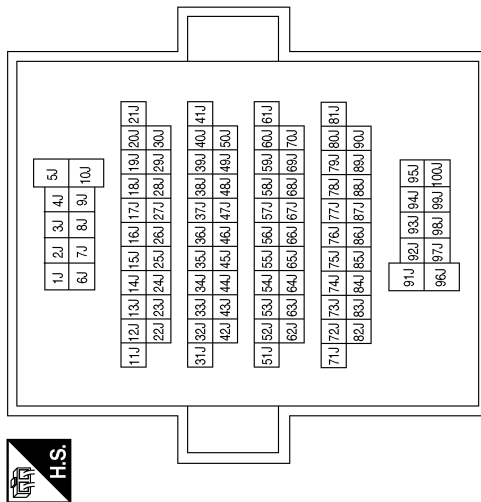

Connector No.	F75
Connector Name	TCM (TRANSMISSION CONTROL MODULE)
Connector Color	BLACK

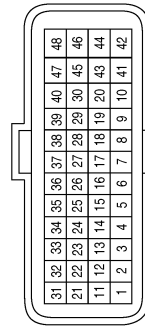

Terminal No.	Color of Wire	Signal Name
23	P	CAN-L
33	L	CAN-H

AA01A0197GB

A
B
C
D
E
F
G
H
I
J
K
L
M
N
P



BASIC INSPECTION

DIAGNOSIS AND REPAIR WORK FLOW

Work Flow

INFOID:0000000011279917

DETAILED FLOW

1.OBTAIN INFORMATION ABOUT SYMPTOM

Interview the customer to obtain as much information as possible about the conditions and environment under which the malfunction occurs.

>> GO TO 2.

2.CHECK SYMPTOM

- Check the symptom based on the information obtained from the customer.
- Check if any other malfunctions are present.

>> GO TO 3.

3.DTC/SYSTEM DIGANOSIS

Perform a DTC/system diagnosis and repair or replace any malfunctioning part.

>> GO TO 4.

4.FINAL CHECK

Check that the SPORT mode functions normally.

Does it operation normally?

- YES >> End of trouble diagnosis
NO >> GO TO 2.

DTC/CIRCUIT DIAGNOSIS**SPORT MODE SWITCH****Component Function Check**

INFOID:0000000011279918

1. CHECK SPORT MODE SWITCH OPERATION

1. Turn ignition switch ON.
2. Check SPORT mode indicator lamp turns ON/OFF on combination meter when turn SPORT mode switch ON/OFF.

Is the inspection result normal?

- YES >> INSPECTION END
 NO >> Proceed to [DMS-15, "Diagnosis Procedure"](#).

Diagnosis Procedure

INFOID:0000000011279919

1. CHECK SPORT MODE SWITCH CIRCUIT

1. Turn ignition switch OFF.
2. Disconnect SPORT mode switch harness connector.
3. Turn ignition switch ON.
4. Check voltage between SPORT mode switch harness connector terminals.

SPORT mode switch			Voltage (Approx.)
Connector	+	-	
	Terminal		
M2	6	8	5 V

Is the inspection result normal?

- YES >> GO TO 6.
 NO >> GO TO 2.

2. CHECK GROUND CIRCUIT

1. Turn ignition switch OFF.
2. Check the continuity between SPORT mode switch harness connector and ground.

SPORT mode switch		—	Continuity
Connector	Terminal		
M2	8	Ground	Existed

Is the inspection result normal?

- YES >> GO TO 3.
 NO >> Repair or replace damaged parts.

3. CHECK CIRCUIT BETWEEN COMBINATION METER AND SPORT MODE SWITCH (1)

1. Disconnect combination meter harness connector M76.
2. Check continuity between combination meter harness connector terminal and SPORT mode switch harness connector terminal.

Combination meter		SPORT mode switch		Continuity
Connector	Terminal	Connector	Terminal	
M76	29	M2	6	Existed

Is the inspection result normal?

- YES >> GO TO 4.
 NO >> Repair or replace damaged parts.

4. CHECK CIRCUIT BETWEEN COMBINATION METER AND SPORT MODE SWITCH (2)

A

B

C

D

E

F

G

H

I

J

K

L

M

N

DMS

P

SPORT MODE SWITCH

< DTC/CIRCUIT DIAGNOSIS >

[SPORT MODE]

Check continuity between combination meter harness connector terminal and SPORT mode switch harness connector terminal.

Combination meter		—	Continuity
Connector	Terminal		
M76	29	Ground	Not existed

Is the inspection result normal?

- YES >> GO TO 5.
- NO >> Repair or replace damaged parts.

5.CHECK COMBINATION METER INPUT/OUTPUT SIGNAL

1. Connect all of disconnected connectors.
2. Check input/output signal of combination meter. Refer to [MWI-25, "Reference Value"](#).

Is the inspection result normal?

- YES >> Check intermittent incident. Refer to [GI-44, "Intermittent Incident"](#).
- NO >> Replace combination meter. Refer to [MWI-84, "Removal and Installation"](#).

6.CHECK SPORT MODE SWITCH

Check SPORT mode switch. Refer to [DMS-16, "Component Inspection"](#).

Is the inspection result normal?

- YES >> Check intermittent incident. Refer to [GI-44, "Intermittent Incident"](#).
- NO >> Replace SPORT mode switch. Refer to [DMS-18, "Removal and Installation"](#).

Component Inspection

INFOID:0000000011279920

1.CHECK SPORT MODE SWITCH

Check continuity between SPORT mode switch connector terminals.

SPORT mode switch	Condition	Continuity
Terminal		
6 – 8	SPORT mode switch is depressed.	Existed
	SPORT mode switch is released.	Not existed

Is the inspection result normal?

- YES >> INSPECTION END
- NO >> Replace SPORT mode switch. Refer to [DMS-18, "Removal and Installation"](#).

THE SPORT MODE INDICATOR LAMP DOES NOT TURN ON

< SYMPTOM DIAGNOSIS >

[SPORT MODE]

SYMPTOM DIAGNOSIS

THE SPORT MODE INDICATOR LAMP DOES NOT TURN ON

Description

INFOID:0000000011279921

The SPORT mode indicator lamp does not turn ON when the SPORT mode switch is operated.

Diagnosis Procedure

INFOID:0000000011279922

1. CHECK SPORT MODE INDICATOR LAMP FUNCTION

Perform combination meter self-diagnosis mode and check test order 10. Refer to [MWI-19. "Description"](#).

Is the check result normal?

YES >> GO TO 2.

NO >> Replace combination meter. Refer to [MWI-84. "Removal and Installation"](#).

2. CHECK DTC (TCM)

 **With CONSULT**

1. Start the engine.
2. Check "Self Diagnostic Results" in "TRANSMISSION".

Is any DTC detected?

YES >> Check DTC detected item. Refer to [TM-63. "DTC Index"](#).

NO >> GO TO 3.

3. CHECK DTC (ECM)

 **With CONSULT**

Check "Self Diagnostic Results" in "ENGINE".

Is any DTC detected?

YES >> Check DTC detected item. Refer to [EC-96. "DTC Index"](#).

NO >> GO TO 4.

4. CHECK DTC (COMBINATION METER)

 **With CONSULT**

Check "Self Diagnostic Results" in "METER/M&A".

Is any DTC detected?

YES >> Check DTC detected item. Refer to [MWI-31. "DTC Index"](#).

NO >> GO TO 5.

5. CHECK COMBINATION METER INPUT/OUTPUT SIGNAL

 **With CONSULT**

1. Select "Data Monitor" in "METER/M&A".
2. Select "SPORT MODE IND".
3. Check that "SPORT MODE IND" turns ON/OFF when SPORT mode switch is operated. Refer to [MWI-25. "Reference Value"](#).

Is any DTC detected?

YES >> Replace combination meter. Refer to [MWI-84. "Removal and Installation"](#).

NO >> GO TO 6.

6. CHECK SPORT MODE SWITCH CIRCUIT

Check SPORT mode switch circuit. Refer to [DMS-15. "Diagnosis Procedure"](#).

Is any DTC detected?

YES >> INSPECTION END

NO >> Repair or replace malfunctioning parts.

REMOVAL AND INSTALLATION

SPORT MODE SWITCH

Removal and Installation

INFOID:0000000011279923

REMOVAL

1. Remove instrument lower panel LH. Refer to [JP-23. "Removal and Installation"](#).
2. Release pawls using suitable tool and remove SPORT mode switch (1) from instrument lower panel LH.

: Pawl

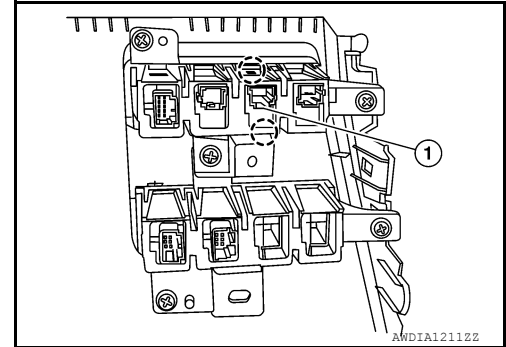

INSTALLATION

Installation is in the reverse order of removal.

PRECAUTION

PRECAUTIONS

Precaution for Supplemental Restraint System (SRS) "AIR BAG" and "SEAT BELT PRE-TENSIONER"

INFOID:000000011317484

The Supplemental Restraint System such as "AIR BAG" and "SEAT BELT PRE-TENSIONER", used along with a front seat belt, helps to reduce the risk or severity of injury to the driver and front passenger for certain types of collision. Information necessary to service the system safely is included in the SR and SB section of this Service Manual.

WARNING:

- To avoid rendering the SRS inoperative, which could increase the risk of personal injury or death in the event of a collision which would result in air bag inflation, all maintenance must be performed by an authorized NISSAN/INFINITI dealer.
- Improper maintenance, including incorrect removal and installation of the SRS, can lead to personal injury caused by unintentional activation of the system. For removal of Spiral Cable and Air Bag Module, see the SR section.
- Do not use electrical test equipment on any circuit related to the SRS unless instructed to in this Service Manual. SRS wiring harnesses can be identified by yellow and/or orange harnesses or harness connectors.

PRECAUTIONS WHEN USING POWER TOOLS (AIR OR ELECTRIC) AND HAMMERS

WARNING:

- When working near the Airbag Diagnosis Sensor Unit or other Airbag System sensors with the Ignition ON or engine running, DO NOT use air or electric power tools or strike near the sensor(s) with a hammer. Heavy vibration could activate the sensor(s) and deploy the air bag(s), possibly causing serious injury.
- When using air or electric power tools or hammers, always switch the Ignition OFF, disconnect the battery and wait at least three minutes before performing any service.

Precaution for Work

INFOID:000000011376590

- When removing or disassembling each component, be careful not to damage or deform it. If a component may be subject to interference, be sure to protect it with a shop cloth.
- When removing (disengaging) components with a screwdriver or similar tool, be sure to wrap the component with a shop cloth or vinyl tape to protect it.
- Protect the removed parts with a shop cloth and prevent them from being dropped.
- Replace a deformed or damaged clip.
- If a part is specified as a non-reusable part, always replace it with a new one.
- Be sure to tighten bolts and nuts securely to the specified torque.
- After installation is complete, be sure to check that each part works properly.
- Follow the steps below to clean components:
 - Water soluble dirt:
 - Dip a soft cloth into lukewarm water, wring the water out of the cloth and wipe the dirty area.
 - Then rub with a soft, dry cloth.
 - Oily dirt:
 - Dip a soft cloth into lukewarm water with mild detergent (concentration: within 2 to 3%) and wipe the dirty area.
 - Then dip a cloth into fresh water, wring the water out of the cloth and wipe the detergent off.
 - Then rub with a soft, dry cloth.
 - Do not use organic solvent such as thinner, benzene, alcohol or gasoline.
 - For genuine leather seats, use a genuine leather seat cleaner.

A
B
C
D
E
F
G
H
I
J
K
L
M
N
DMS
P

PREPARATION

< PREPARATION >

[ECO MODE]

PREPARATION

PREPARATION

Special Service Tool

INFOID:000000011376591

The actual shape of the tools may differ from those illustrated here.

Tool number (TechMate No.) Tool name	Description
— (J-46534) Trim Tool Set	Removing trim components

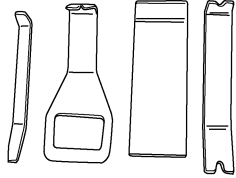

AWJIA04832Z

COMPONENT PARTS

< SYSTEM DESCRIPTION >

[ECO MODE]

SYSTEM DESCRIPTION

COMPONENT PARTS

Component Parts Location

INFOID:0000000011317485

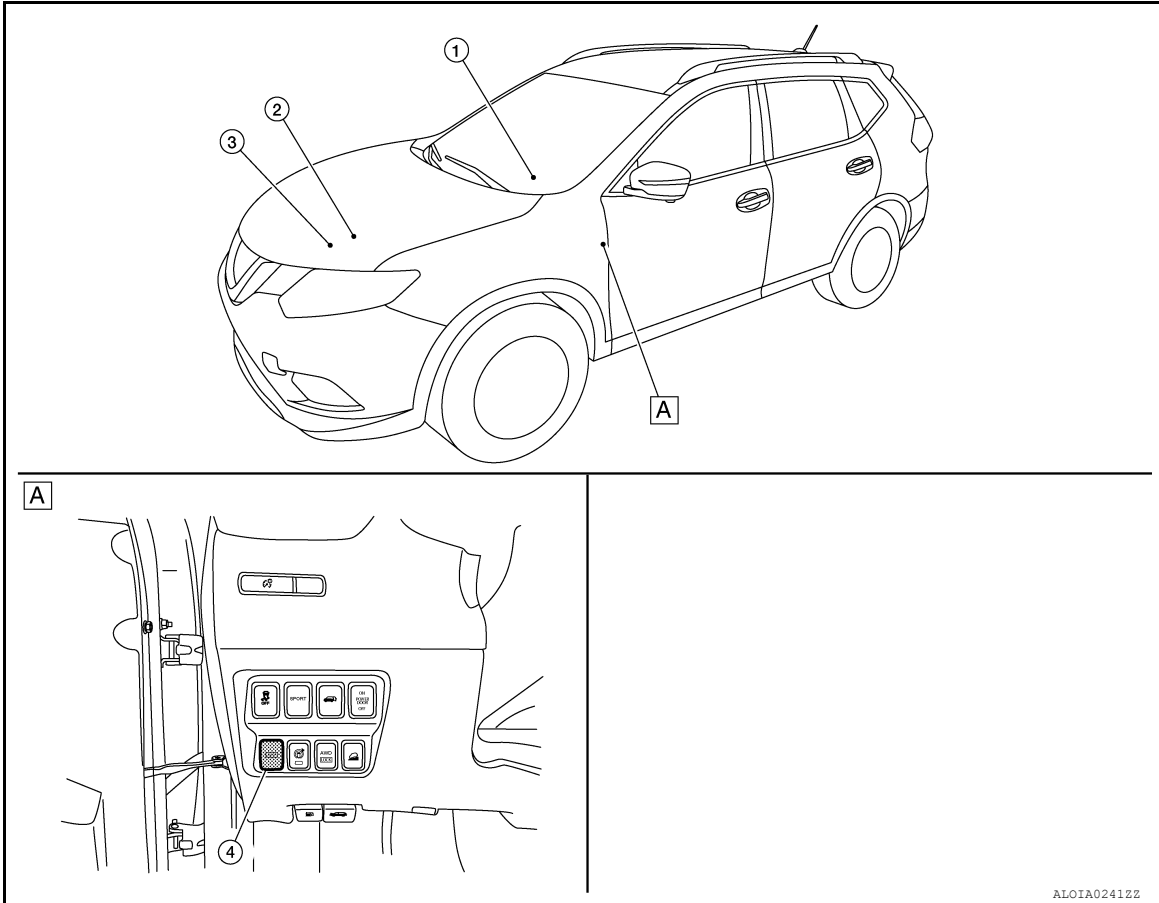

A Instrument lower panel LH

COMPONENT DESCRIPTION

No.	Component	Function
①	Combination meter	<ul style="list-style-type: none"> The combination meter transmits the following signal via CAN communications to the TCM. <ul style="list-style-type: none"> - ECO mode switch signal The combination meter receives the following signal via CAN communications from the ECM. <ul style="list-style-type: none"> - ECO mode indicator signal Refer to MWI-6, "METER SYSTEM : Component Parts Location" for detailed installation location.
②	TCM	<ul style="list-style-type: none"> The TCM receives the following signal via CAN communications from the combination meter. <ul style="list-style-type: none"> - ECO mode switch signal The TCM transmits the following signal via CAN communications to the ECM. <ul style="list-style-type: none"> - ECO mode signal Refer to TM-12, "CVT CONTROL SYSTEM : Component Parts Location" for detailed installation location.

A
B
C
D
E
F
G
H
I
J
K
L
M
N
P

DMS

COMPONENT PARTS

< SYSTEM DESCRIPTION >

[ECO MODE]

No.	Component	Function
③	ECM	<ul style="list-style-type: none"> The ECM receives the following signal via CAN communications from the TCM. <ul style="list-style-type: none"> - ECO mode signal The ECM transmits the following signal via CAN communications to the combination meter. <ul style="list-style-type: none"> - ECO mode indicator signal Refer to EC-14, "Component Parts Location" for detailed installation location.
④	ECO mode switch	Refer to DMS-22, "ECO Mode Switch" .

ECO Mode Switch

INFOID:000000011317486

- The ECO mode switch is installed to the instrument lower finisher.
- When the ECO mode indicator lamp on the combination meter is OFF and the ECO mode switch is pressed, the ECO mode is active and the ECO mode indicator lamp is ON.
- When the ECO mode indicator lamp on the combination meter is ON and the ECO mode switch is pressed, the ECO mode is cancelled and the ECO mode indicator lamp is OFF.

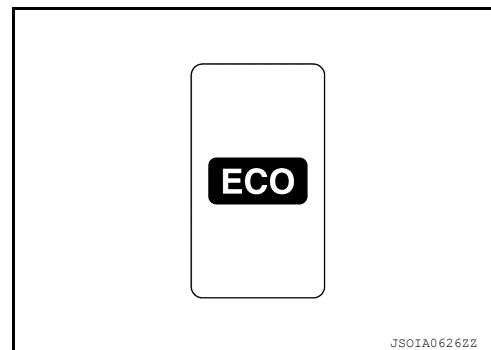

ECO Mode Indicator Lamp

INFOID:000000011317487

DESIGN/PURPOSE

The ECO mode indicator lamp inform the driver that the vehicle is in ECO mode.

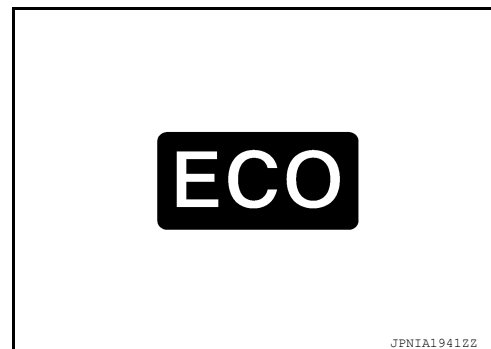

BULB CHECK

Not applicable

SIGNAL PATH

- TCM receives ECO mode switch signal (ON/OFF) from combination meter via CAN communication. Based on the signal, TCM transmits ECO mode signal to ECM via CAN communication.
- ECM transmits ECO mode indicator signal to combination meter via CAN communication. Based on the signal, combination meter illuminates ECO mode indicator lamp.

LIGHTING CONDITION

When all of the following conditions are satisfied.

- Ignition switch: ON
- The ECO mode switch is pressed when the ECO mode indicator lamp is OFF

SHUTOFF CONDITION

When any of the condition listed below is satisfied.

- Ignition switch: Other than ON
- The ECO mode switch is pressed when the ECO mode indicator lamp is ON.
- The SPORT mode switch is pressed when the ECO mode indicator lamp is ON.

SYSTEM

ECO MODE CONTROL

ECO MODE CONTROL : System Description

INFOID:000000011317488

SYSTEM DIAGRAM

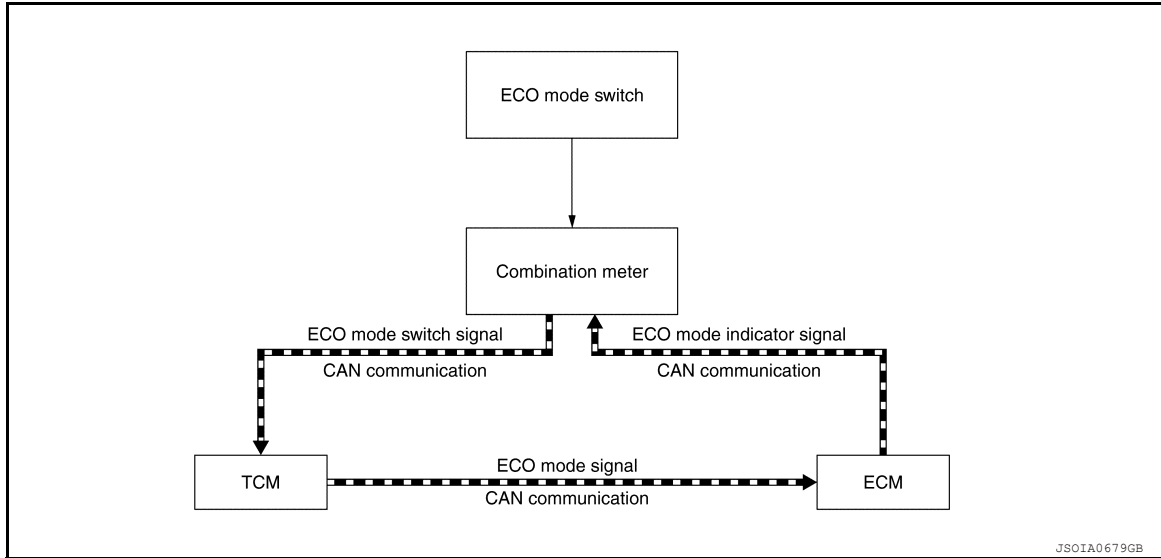

SYSTEM DISCRIPTION

- TCM receive ECO mode switch signal (ON/OFF) from combination meter via CAN communication. TCM transmit ECO mode signal to ECM via CAN communication according to the signal.
- ECM transmit ECO mode indicator signal to combination meter via CAN communication. Combination meter illuminates ECO mode indicator lamp according to the signal.

Each ECU Control

- For TCM control, refer to [TM-43. "ECO MODE SYSTEM : System Description"](#).
- For ECM control, refer to [EC-56. "ECO MODE CONTROL : System Description"](#).

A
B
C
D
E
F
G
H
I
J
K
L
M
N
P

DMS

ECU DIAGNOSIS INFORMATION

ECO MODE

List of ECU Reference

INFOID:0000000011317489

ECU	Reference
TCM	TM-52, "Reference Value"
	TM-58, "Fail-safe"
	TM-62, "DTC Inspection Priority Chart"
	TM-63, "DTC Index"
ECM	EC-80, "Reference Value"
	EC-92, "Fail Safe"
	EC-95, "DTC Inspection Priority Chart"
	EC-96, "DTC Index"
Combination meter	MWI-25, "Reference Value"
	MWI-30, "Fail-safe"
	MWI-31, "DTC Index"

ECO MODE SYSTEM

< WIRING DIAGRAM >

[ECO MODE]

WIRING DIAGRAM

ECO MODE SYSTEM

Wiring Diagram

INFOID:0000000011317490

ECO MODE SYSTEM

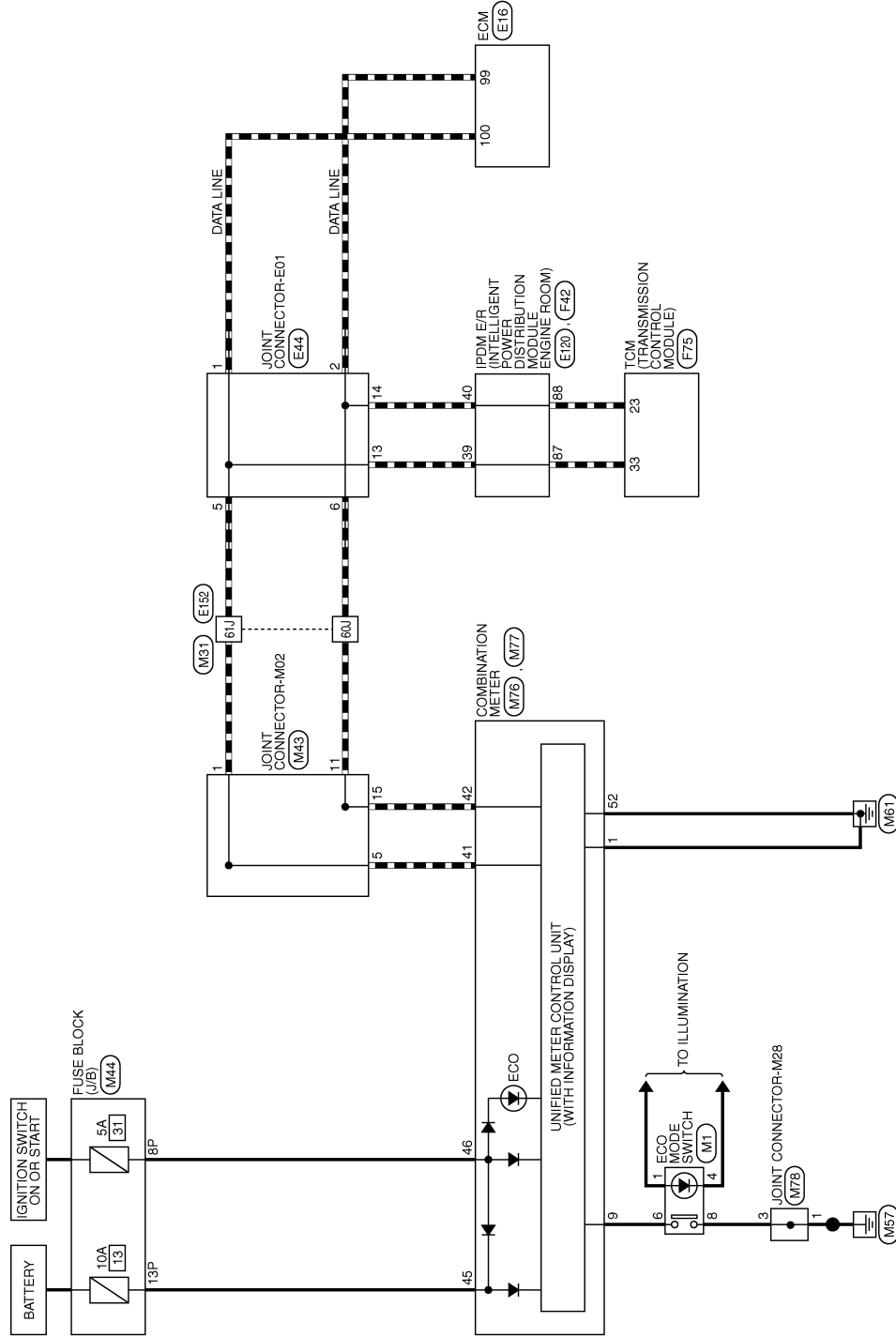

AAOWA0057GB

A
B
C
D
E
F
G
H
I
J
K
L
M
N
P

DMS

ECO SYSTEM CONNECTORS

Connector No.	M1
Connector Name	ECO MODE SWITCH
Connector Color	GRAY

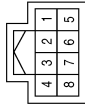

Terminal No.	Color of Wire	Signal Name
1	G	-
4	GR	-
6	GR	-
8	GR	-

Connector No.	M31
Connector Name	WIRE TO WIRE
Connector Color	WHITE

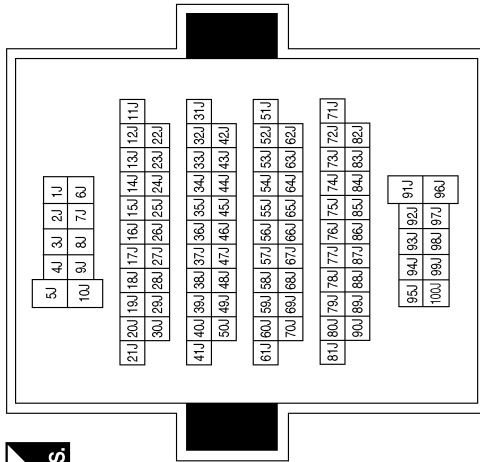

Terminal No.	Color of Wire	Signal Name
60J	P	-
61J	L	-

Connector No.	M43
Connector Name	JOINT CONNECTOR-M02
Connector Color	BLUE

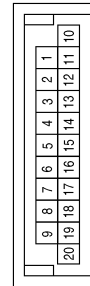

Terminal No.	Color of Wire	Signal Name
1	L	-
5	L	-
11	P	-
15	P	-

Connector No.	M44
Connector Name	FUSE BLOCK (J/B)
Connector Color	WHITE



Terminal No.	Color of Wire	Signal Name
8P	LA/BR	-
13P	LA/G	-

ECO MODE SYSTEM

< WIRING DIAGRAM >

[ECO MODE]

Connector No.	M78
Connector Name	JOINT CONNECTOR-M28
Connector Color	WHITE



Terminal No.	Color of Wire	Signal Name
1	GR	-
3	GR	-

Connector No.	M77
Connector Name	COMBINATION METER
Connector Color	WHITE

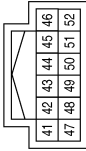

Terminal No.	Color of Wire	Signal Name
41	L	CAN-H
42	P	CAN-L
45	LA/G	BAT
46	LA/BR	IGN
52	B	G1

Connector No.	M76
Connector Name	COMBINATION METER
Connector Color	WHITE

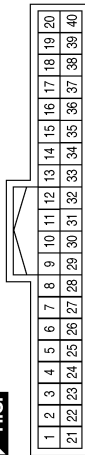

Terminal No.	Color of Wire	Signal Name
1	B	GND
9	GR	ECO MODE SW

Terminal No.	Color of Wire	Signal Name
1	L	-
2	P	-
5	L	-
6	P	-
13	L	-
14	P	-

Connector No.	E44
Connector Name	JOINT CONNECTOR-E01
Connector Color	WHITE

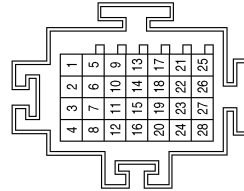

Connector No.	E16
Connector Name	ECM
Connector Color	BLACK

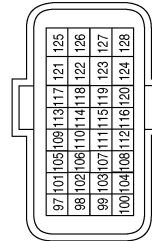

Terminal No.	Color of Wire	Signal Name
99	P	CAN-L
100	L	CAN-H

AA0IA0213GB

A
B
C
D
E
F
G
H
I
J
K
L
M
N
P



ECO MODE SYSTEM

< WIRING DIAGRAM >

[ECO MODE]

Terminal No.	Color of Wire	Signal Name
60J	P	-
61J	L	-

Connector No.	E152
Connector Name	WIRE TO WIRE
Connector Color	WHITE

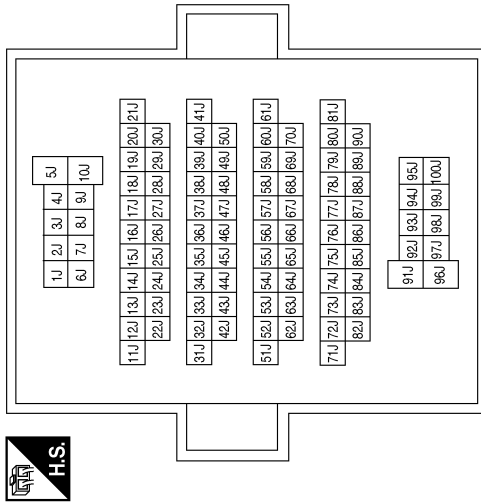

Connector No.	E120
Connector Name	IPDM E/R (INTELLIGENT POWER DISTRIBUTION MODULE ENGINE ROOM)
Connector Color	GRAY

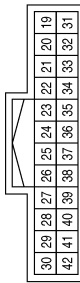

Terminal No.	Color of Wire	Signal Name
39	L	CAN-H
40	P	CAN-L

Connector No.	F75
Connector Name	TCM (TRANSMISSION CONTROL MODULE)
Connector Color	BLACK

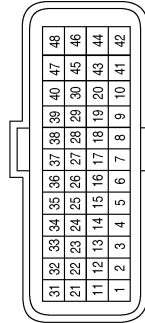

Terminal No.	Color of Wire	Signal Name
23	P	CAN-L
33	L	CAN-H

Connector No.	F42
Connector Name	IPDM E/R (INTELLIGENT POWER DISTRIBUTION MODULE ENGINE ROOM)
Connector Color	BLACK

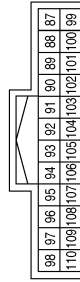

Terminal No.	Color of Wire	Signal Name
87	L	CAN-H
88	P	CAN-L

DIAGNOSIS AND REPAIR WORK FLOW

< BASIC INSPECTION >

[ECO MODE]

BASIC INSPECTION

DIAGNOSIS AND REPAIR WORK FLOW

Work Flow

INFOID:0000000011317491

DETAILED FLOW

1.OBTAIN INFORMATION ABOUT SYMPTOM

Interview the customer to obtain as much information as possible about the conditions and environment under which the malfunction occurs.

>> GO TO 2.

2.CHECK SYMPTOM

- Check the symptom based on the information obtained from the customer.
- Check if any other malfunctions are present.

>> GO TO 3.

3.DTC/SYSTEM DIGANOSIS

Perform a DTC/system diagnosis and repair or replace any malfunctioning part.

>> GO TO 4.

4.FINAL CHECK

Check that the ECO mode functions normally.

Does it operation normally?

- YES >> End of trouble diagnosis
- NO >> GO TO 2.

A
B
C
D
E
F
G
H
I
J
K
L
M
N
P

DMS

DTC/CIRCUIT DIAGNOSIS

ECO MODE SWITCH

Component Function Check

INFOID:000000011317492

1. CHECK ECO MODE SWITCH OPERATION

1. Turn ignition switch ON.
2. Check ECO mode indicator lamp turns ON/OFF on combination meter when turn ECO mode switch ON/OFF.

Is the inspection result normal?

- YES >> INSPECTION END
 NO >> Go to [DMS-33. "Diagnosis Procedure"](#).

Diagnosis Procedure

INFOID:000000011317493

1. DETECT MALFUNCTIONING ITEMS

What is malfunction item?

- ECO mode switch illumination does not turn ON>>GO TO 2.
 ECO mode indicator does not turn ON>>GO TO 7.

2. CHECK ECO MODE SWITCH ILLUMINATION POWER SUPPLY (PART 1)

1. Turn OFF the headlamp.
2. Turn ignition switch OFF.
3. Disconnect ECO mode switch harness connector.
4. Turn ignition switch ON.
5. Turn ON the headlamp.
6. Check the voltage between ECO mode switch harness connector terminals.

ECO mode switch			Voltage (Approx.)
Connector	+	-	
		Terminal	
M1	1	4	12 V

Is the inspection result normal?

- YES >> GO TO 3.
 NO >> GO TO 4.

3. CHECK INTERMITTENT INCIDENTS

Refer to [GI-44. "Intermittent Incident"](#).

Is the inspection result normal?

- YES >> Replace ECO mode switch. Refer to [DMS-34. "Removal and Installation"](#).
 NO >> Replace the fuse after repair the applicable circuit.

4. CHECK ECO MODE SWITCH ILLUMINATION POWER SUPPLY (PART 2)

Check the voltage between ECO mode switch harness connector and ground.

+		-	Voltage (Approx.)
ECO mode switch			
Connector	Terminal		
M1	1	Ground	12 V

Is the inspection result normal?

- YES >> GO TO 6.
 NO >> GO TO 5.

ECO MODE SWITCH

< DTC/CIRCUIT DIAGNOSIS >

[ECO MODE]

5. CHECK CIRCUIT BETWEEN COMBINATION METER AND ECO MODE SWITCH

1. Disconnect combination meter connector M77.
2. Check the continuity between combination meter harness connector terminal and ECO mode switch harness connector terminal.

Combination meter		ECO mode switch		Continuity
Connector	Terminal	Connector	Terminal	
M77	43	M1	1	Existed

3. Also check harness for short to ground.

Is the inspection result normal?

YES >> GO TO 11.

NO >> Repair or replace malfunctioning parts.

6. CHECK GROUND CIRCUIT

1. Turn OFF the headlamp.
2. Turn ignition switch OFF.
3. Check continuity between ECO mode switch harness connector terminal and ground.

ECO mode switch		—	Continuity
Connector	Terminal		
M1	4	Ground	Existed

Is the inspection result normal?

YES >> Check intermittent incident. Refer to [GI-44. "Intermittent Incident"](#).

NO >> Repair or replace malfunctioning parts.

7. CHECK ECO MODE SWITCH CIRCUIT

1. Turn ignition switch OFF.
2. Disconnect ECO mode switch connector.
3. Turn ignition switch ON.
4. Check voltage between ECO mode switch harness connector terminals.

Connector	ECO mode switch		Voltage (Approx.)
	+	-	
	Terminal		
M1	6	8	10 V

Is the inspection result normal?

YES >> GO TO 12.

NO >> GO TO 8.

8. CHECK GROUND CIRCUIT

1. Turn ignition switch OFF.
2. Check the continuity between ECO mode switch harness connector and ground.

ECO mode switch		—	Continuity
Connector	Terminal		
M1	8	Ground	Existed

Is the inspection result normal?

YES >> GO TO 9.

NO >> Repair or replace malfunctioning parts.

9. CHECK CIRCUIT BETWEEN COMBINATION METER AND ECO MODE SWITCH (PART 1)

1. Disconnect combination meter harness connector M76.

A
B
C
D
E
F
G
H
I
J
K
L
M
N

DMS

P

ECO MODE SWITCH

[ECO MODE]

< DTC/CIRCUIT DIAGNOSIS >

2. Check continuity between combination meter harness connector terminal and ECO mode switch harness connector terminal.

Combination meter		ECO mode switch		Continuity
Connector	Terminal	Connector	Terminal	
M76	9	M1	6	Existed

Is the inspection result normal?

YES >> GO TO 10.

NO >> Repair or replace malfunctioning parts.

10.CHECK CIRCUIT BETWEEN COMBINATION METER AND ECO MODE SWITCH (PART 2)

Check continuity between combination meter harness connector terminal and ground.

Combination meter		—	Continuity
Connector	Terminal		
M76	9	Ground	Not existed

Is the inspection result normal?

YES >> GO TO 11.

NO >> Repair or replace malfunctioning parts.

11.CHECK COMBINATION METER INPUT/OUTPUT SIGNAL

1. Connect all of disconnected connectors.
2. Check input/output signal of combination meter. Refer to [MWI-25, "Reference Value"](#).

Is the inspection result normal?

YES >> Check intermittent incident. Refer to [GI-44, "Intermittent Incident"](#).

NO >> Replace combination meter. Refer to [MWI-84, "Removal and Installation"](#).

12.CHECK ECO MODE SWITCH

Check ECO mode switch. Refer to [DMS-32, "Component Inspection"](#).

Is the inspection result normal?

YES >> Check intermittent incident. Refer to [GI-44, "Intermittent Incident"](#).

NO >> Replace ECO mode switch. Refer to [DMS-34, "Removal and Installation"](#).

Component Inspection

INFOID:0000000011317494

1.CHECK ECO MODE SWITCH

Check continuity between ECO mode switch connector terminals.

ECO mode switch	Condition	Continuity
Terminal		
6 – 8	ECO mode switch is depressed.	Existed
	ECO mode switch is released.	Not existed

Is the inspection result normal?

YES >> INSPECTION END

NO >> Replace ECO mode switch. Refer to [DMS-34, "Removal and Installation"](#).

THE ECO MODE INDICATOR LAMP DOES NOT TURN ON

< SYMPTOM DIAGNOSIS >

[ECO MODE]

SYMPTOM DIAGNOSIS

THE ECO MODE INDICATOR LAMP DOES NOT TURN ON

Description

INFOID:0000000011317495

The ECO mode indicator lamp does not turn ON when the ECO mode switch is operated.

Diagnosis Procedure

INFOID:0000000011317496

1. PERFORM COMBINATION METER ON BOARD DIAGNOSIS

Perform combination meter on board diagnosis. Refer to [MWI-19. "Description"](#).

Is the check result normal?

YES >> GO TO 2.

NO >> Replace combination meter. Refer to [MWI-84. "Removal and Installation"](#).

2. CHECK DTC (TCM)

Ⓜ With CONSULT

1. Start the engine.
2. Check "Self Diagnostic Results" in "TRANSMISSION".

Is any DTC detected?

YES >> Check DTC detected item. Refer to [TM-63. "DTC Index"](#).

NO >> GO TO 3.

3. CHECK DTC (ECM)

Ⓜ With CONSULT

Check "Self Diagnostic Results" in "ENGINE".

Is any DTC detected?

YES >> Check DTC detected item. Refer to [EC-96. "DTC Index"](#).

NO >> GO TO 4.

4. CHECK DTC (COMBINATION METER)

Ⓜ With CONSULT

Check "Self Diagnostic Results" in "METER/M&A".

Is any DTC detected?

YES >> Check DTC detected item. Refer to [MWI-31. "DTC Index"](#).

NO >> GO TO 5.

5. CHECK COMBINATION METER INPUT/OUTPUT SIGNAL

Ⓜ With CONSULT

1. Select "Data Monitor" in "METER/M&A".
2. Select "ECO MODE IND".
3. Check that "ECO MODE IND" turns ON/OFF when ECO mode switch is operated. Refer to [MWI-25. "Reference Value"](#).

Is any DTC detected?

YES >> Replace combination meter. Refer to [MWI-86. "Disassembly and Assembly"](#).

NO >> GO TO 6.

6. CHECK ECO MODE SWITCH CIRCUIT

Check ECO mode switch circuit. Refer to [DMS-30. "Diagnosis Procedure"](#).

Is any DTC detected?

YES >> INSPECTION END

NO >> Repair or replace malfunctioning parts.

A
B
C
D
E
F
G
H
I
J
K
L
M
N
P

DMS

REMOVAL AND INSTALLATION

ECO MODE SWITCH

Removal and Installation

INFOID:000000011317497

REMOVAL

1. Remove instrument lower panel LH. Refer to [JP-23. "Removal and Installation"](#).
2. Release pawls using suitable tool and remove ECO mode switch from instrument lower panel LH.

INSTALLATION

Installation is in the reverse order of removal.