

A  
EC  
C  
D  
E  
F  
G  
H  
I  
J  
K  
L  
M  
N  
O  
P

# SECTION EC

## ENGINE CONTROL SYSTEM

### CONTENTS

#### QR25DE

<b>PRECAUTION</b> .....		
<b>PRECAUTIONS</b> .....		
Precaution for Supplemental Restraint System (SRS) "AIR BAG" and "SEAT BELT PRE-TENSIONER" .....	8	
Precaution for Procedure without Cowl Top Cover.....	8	
On Board Diagnostic (OBD) System of Engine and CVT .....	8	
General Precautions .....	9	
<b>PREPARATION</b> .....	12	
<b>PREPARATION</b> .....	12	
Special Service Tools .....	12	
Commercial Service Tools .....	12	
<b>SYSTEM DESCRIPTION</b> .....	14	
<b>COMPONENT PARTS</b> .....	14	
Component Parts Location .....	14	
ECM .....	18	
Accelerator Pedal Position Sensor .....	18	
Electric Throttle Control Actuator .....	19	
Ignition Coil With Power Transistor .....	19	
Fuel Injector .....	20	
Fuel Level Sensor Unit and Fuel Pump .....	20	
Fuel Tank Temperature Sensor .....	20	
Mass Air Flow Sensor (With Intake Air Temperature Sensor) .....	21	
Engine Coolant Temperature Sensor .....	21	
Crankshaft Position Sensor (POS) .....	22	
Camshaft Position Sensor (PHASE) .....	22	
Intake Valve Timing Control Solenoid Valve .....	23	
Intake Valve Timing Intermediate Lock Control Solenoid Valve .....	23	
Exhaust Valve Timing Control Position Sensor .....	23	
Exhaust Valve Timing Control Solenoid Valve .....	24	
Intake Manifold Runner Control Valve .....	24	
Air Fuel Ratio (A/F) Sensor 1 .....	24	
Heated Oxygen Sensor 2 .....	25	
Knock Sensor .....	25	
Engine Oil Pressure Sensor .....	26	
Engine Oil Temperature Sensor .....	26	
Cooling Fan .....	26	
EVAP Canister .....	27	
EVAP Canister Purge Volume Control Solenoid Valve .....	27	
EVAP Canister Vent Control Valve .....	27	
EVAP Control System Pressure Sensor .....	27	
Refrigerant Pressure Sensor .....	28	
Stop Lamp Switch & Brake Pedal Position Switch.....	28	
ASCD Steering Switch .....	28	
Information Display .....	28	
<b>STRUCTURE AND OPERATION</b> .....	29	
Positive Crankcase Ventilation .....	29	
On Board Refueling Vapor Recovery (ORVR) .....	30	
<b>SYSTEM</b> .....	31	
<b>ENGINE CONTROL SYSTEM</b> .....	31	
ENGINE CONTROL SYSTEM : System Description .....	31	
ENGINE CONTROL SYSTEM : Circuit Diagram .....	33	
ENGINE CONTROL SYSTEM : Fail Safe .....	34	
<b>MULTIPOINT FUEL INJECTION SYSTEM</b> .....	37	
MULTIPOINT FUEL INJECTION SYSTEM : System Description (with automatic air conditioner) .....	37	
MULTIPOINT FUEL INJECTION SYSTEM : System Description (with manual air conditioner) .....	39	
<b>ELECTRIC IGNITION SYSTEM</b> .....	41	
ELECTRIC IGNITION SYSTEM : System Description .....	41	
<b>INTAKE VALVE TIMING CONTROL</b> .....	42	
INTAKE VALVE TIMING CONTROL : System Description .....	42	
<b>EXHAUST VALVE TIMING CONTROL</b> .....	44	

EXHAUST VALVE TIMING CONTROL : System Description .....	45	Diagnosis Description .....	58
		GST (Generic Scan Tool) .....	58
<b>INTAKE MANIFOLD RUNNER CONTROL .....</b>	<b>45</b>	<b>DIAGNOSIS SYSTEM (ECM) .....</b>	<b>59</b>
INTAKE MANIFOLD RUNNER CONTROL : System Description .....	46	<b>DIAGNOSIS DESCRIPTION .....</b>	<b>59</b>
<b>ENGINE PROTECTION CONTROL AT LOW ENGINE OIL PRESSURE .....</b>	<b>46</b>	DIAGNOSIS DESCRIPTION : 1st Trip Detection Logic and Two Trip Detection Logic .....	59
ENGINE PROTECTION CONTROL AT LOW ENGINE OIL PRESSURE : System Description .....	46	DIAGNOSIS DESCRIPTION : DTC and Freeze Frame Data .....	59
<b>AIR CONDITIONING CUT CONTROL .....</b>	<b>46</b>	DIAGNOSIS DESCRIPTION : Counter System .....	60
AIR CONDITIONING CUT CONTROL : System Description .....	47	DIAGNOSIS DESCRIPTION : Driving Pattern .....	63
<b>POWER GENERATION VOLTAGE VARIABLE CONTROL SYSTEM .....</b>	<b>47</b>	DIAGNOSIS DESCRIPTION : System Readiness Test (SRT) Code .....	64
POWER GENERATION VOLTAGE VARIABLE CONTROL SYSTEM : System Description .....	47	DIAGNOSIS DESCRIPTION : Permanent Diagnostic Trouble Code (Permanent DTC) .....	65
<b>COOLING FAN CONTROL .....</b>	<b>47</b>	DIAGNOSIS DESCRIPTION : Malfunction Indicator Lamp (MIL) .....	66
COOLING FAN CONTROL : System Description .....	48	On Board Diagnosis Function .....	66
<b>AUTOMATIC SPEED CONTROL DEVICE (ASCD)..</b>	<b>49</b>	CONSULT Function .....	69
AUTOMATIC SPEED CONTROL DEVICE (ASCD) : System Description .....	49	<b>ECU DIAGNOSIS INFORMATION .....</b>	<b>80</b>
<b>FUEL FILLER CAP WARNING SYSTEM .....</b>	<b>50</b>	<b>ECM .....</b>	<b>80</b>
FUEL FILLER CAP WARNING SYSTEM : System Description .....	50	Reference Value .....	80
<b>WARNING/INDICATOR/CHIME LIST .....</b>	<b>51</b>	Fail Safe .....	92
WARNING/INDICATOR/CHIME LIST : Warning lamps/Indicator lamps .....	51	DTC Inspection Priority Chart .....	95
WARNING/INDICATOR/CHIME LIST : Warning/Indicator (On Information Display) .....	51	DTC Index .....	96
WARNING/INDICATOR/CHIME LIST : Malfunction Indicator Lamp (MIL) .....	51	Test Value and Test Limit .....	100
WARNING/INDICATOR/CHIME LIST : Engine Oil Pressure Warning .....	53	<b>WIRING DIAGRAM .....</b>	<b>108</b>
WARNING/INDICATOR/CHIME LIST : Fuel Filler Cap Warning .....	54	<b>ENGINE CONTROL SYSTEM .....</b>	<b>108</b>
<b>EVAPORATIVE EMISSION SYSTEM .....</b>	<b>54</b>	Wiring Diagram .....	108
EVAPORATIVE EMISSION SYSTEM : System Description .....	55	<b>BASIC INSPECTION .....</b>	<b>130</b>
<b>CAN COMMUNICATION .....</b>	<b>55</b>	<b>DIAGNOSIS AND REPAIR WORKFLOW .....</b>	<b>130</b>
CAN COMMUNICATION : System Description .....	55	Work Flow .....	130
<b>SPORT MODE CONTROL .....</b>	<b>56</b>	Diagnostic Work Sheet .....	133
SPORT MODE CONTROL : System Description .....	56	<b>BASIC INSPECTION .....</b>	<b>135</b>
<b>ECO MODE CONTROL .....</b>	<b>56</b>	Work Procedure .....	135
ECO MODE CONTROL : System Description .....	56	<b>ADDITIONAL SERVICE WHEN REPLACING ECM .....</b>	<b>139</b>
<b>OPERATION .....</b>	<b>57</b>	Description .....	139
<b>AUTOMATIC SPEED CONTROL DEVICE (ASCD)..</b>	<b>57</b>	Work Procedure .....	139
AUTOMATIC SPEED CONTROL DEVICE (ASCD) : Switch Name and Function .....	57	<b>VIN REGISTRATION .....</b>	<b>141</b>
<b>ON BOARD DIAGNOSTIC (OBD) SYSTEM ....</b>	<b>58</b>	Description .....	141
		Work Procedure .....	141
		<b>ACCELERATOR PEDAL RELEASED POSITION LEARNING .....</b>	<b>142</b>
		Description .....	142
		Work Procedure .....	142
		<b>THROTTLE VALVE CLOSED POSITION LEARNING .....</b>	<b>143</b>
		Description .....	143
		Work Procedure .....	143

<b>IDLE AIR VOLUME LEARNING</b> .....	<b>144</b>	Diagnosis Procedure .....	185	A
Description .....	144	Component Inspection .....	186	
Work Procedure .....	144			
<b>MIXTURE RATIO SELF-LEARNING VALUE CLEAR</b> .....	<b>146</b>	<b>P0030, P0031, P0032 A/F SENSOR 1 HEATER</b> .....	<b>188</b>	<b>EC</b>
Description .....	146	DTC Description .....	188	
Work Procedure .....	146	Diagnosis Procedure .....	188	
		Component Inspection .....	189	
<b>FUEL PRESSURE</b> .....	<b>147</b>	<b>P0037, P0038 HO2S2 HEATER</b> .....	<b>191</b>	C
Work Procedure .....	147	DTC Description .....	191	
		Diagnosis Procedure .....	191	D
<b>HOW TO SET SRT CODE</b> .....	<b>148</b>	Component Inspection .....	192	
Description .....	148	<b>P0075 INTAKE VALVE TIMING CONTROL</b> ...	<b>194</b>	E
SRT Set Driving Pattern .....	149	DTC Description .....	194	
Work Procedure .....	151	Diagnosis Procedure .....	194	
<b>HOW TO ERASE PERMANENT DTC</b> .....	<b>154</b>	Component Inspection (IVT Control Solenoid Valve) .....	196	F
Description .....	154	Component Inspection (IVT Intermediate Lock Control Solenoid Valve) .....	197	
Work Procedure (Group A) .....	155	<b>P0078 EVT CONTROL SOLENOID VALVE</b> ...	<b>198</b>	G
Work Procedure (Group B) .....	157	DTC Description .....	198	
<b>DTC/CIRCUIT DIAGNOSIS</b> .....	<b>160</b>	Diagnosis Procedure .....	198	H
<b>TROUBLE DIAGNOSIS - SPECIFICATION VALUE</b> .....	<b>160</b>	Component Inspection .....	199	
Description .....	160	<b>P0101 MAF SENSOR</b> .....	<b>201</b>	I
Component Function Check .....	160	DTC Description .....	201	
Diagnosis Procedure .....	161	Diagnosis Procedure .....	202	
<b>POWER SUPPLY AND GROUND CIRCUIT</b> ...	<b>168</b>	Component Inspection .....	203	J
Diagnosis Procedure .....	168	<b>P0102, P0103 MAF SENSOR</b> .....	<b>205</b>	
<b>U0101 CAN COMM CIRCUIT</b> .....	<b>172</b>	DTC Description .....	205	K
Description .....	172	Diagnosis Procedure .....	206	
DTC Description .....	172	Component Inspection .....	207	
Diagnosis Procedure .....	172	<b>P0111 IAT SENSOR</b> .....	<b>209</b>	L
<b>U1001 CAN COMM CIRCUIT</b> .....	<b>173</b>	DTC Description .....	209	
Description .....	173	Diagnosis Procedure .....	210	
DTC Description .....	173	Component Inspection .....	210	M
Diagnosis Procedure .....	173	<b>P0112, P0113 IAT SENSOR</b> .....	<b>211</b>	
<b>U1040 ENG COMM CIRCUIT</b> .....	<b>174</b>	DTC Description .....	211	
DTC Description .....	174	Diagnosis Procedure .....	211	N
Diagnosis Procedure .....	174	Component Inspection .....	212	
<b>U1044 ENG COMM CIRCUIT</b> .....	<b>176</b>	<b>P0116 ECT SENSOR</b> .....	<b>214</b>	O
DTC Description .....	176	DTC Description .....	214	
Diagnosis Procedure .....	176	Diagnosis Procedure .....	215	
<b>U1050, U1051 LIN COMMUNICATION</b> .....	<b>178</b>	Component Inspection .....	215	
DTC Description .....	178	<b>P0117, P0118 ECT SENSOR</b> .....	<b>216</b>	P
Diagnosis Procedure .....	178	DTC Description .....	216	
<b>P0011 IVT CONTROL</b> .....	<b>180</b>	Diagnosis Procedure .....	216	
DTC Description .....	180	Component Inspection .....	217	
Diagnosis Procedure .....	181	<b>P0122, P0123 TP SENSOR</b> .....	<b>219</b>	
Component Inspection .....	182	DTC Description .....	219	
<b>P0014 EVT CONTROL</b> .....	<b>184</b>	Diagnosis Procedure .....	219	
DTC Description .....	184	Component Inspection .....	221	

<b>P0125 ECT SENSOR</b> .....	<b>222</b>	<b>P0182, P0183 FTT SENSOR</b> .....	<b>277</b>
DTC Description .....	222	DTC Description .....	277
Diagnosis Procedure .....	223	Diagnosis Procedure .....	277
Component Inspection .....	223	Component Inspection .....	279
<b>P0127 IAT SENSOR</b> .....	<b>224</b>	<b>P0196 EOT SENSOR</b> .....	<b>280</b>
DTC Description .....	224	DTC Description .....	280
Diagnosis Procedure .....	224	Diagnosis Procedure .....	282
Component Inspection .....	225	Component Inspection .....	282
<b>P0128 THERMOSTAT FUNCTION</b> .....	<b>226</b>	<b>P0197, P0198 EOT SENSOR</b> .....	<b>284</b>
DTC Description .....	226	DTC Description .....	284
Diagnosis Procedure .....	227	Diagnosis Procedure .....	284
Component Inspection .....	228	Component Inspection .....	285
<b>P0130 A/F SENSOR 1</b> .....	<b>229</b>	<b>P0222, P0223 TP SENSOR</b> .....	<b>287</b>
DTC Description .....	229	DTC Description .....	287
Diagnosis Procedure .....	230	Diagnosis Procedure .....	287
<b>P0131 A/F SENSOR 1</b> .....	<b>233</b>	Component Inspection .....	289
DTC Description .....	233	<b>P0300, P0301, P0302, P0303, P0304 MIS-</b>	
Diagnosis Procedure .....	234	<b>FIRE</b> .....	<b>290</b>
<b>P0132 A/F SENSOR 1</b> .....	<b>236</b>	DTC Description .....	290
DTC Description .....	236	Diagnosis Procedure .....	291
Diagnosis Procedure .....	237	<b>P0327, P0328 KS</b> .....	<b>296</b>
<b>P0137 HO2S2</b> .....	<b>239</b>	DTC Description .....	296
DTC Description .....	239	Diagnosis Procedure .....	296
Diagnosis Procedure .....	241	Component Inspection .....	297
Component Inspection .....	242	<b>P0335 CKP SENSOR (POS)</b> .....	<b>298</b>
<b>P0138 HO2S2</b> .....	<b>245</b>	DTC Description .....	298
DTC Description .....	245	Diagnosis Procedure .....	298
Diagnosis Procedure .....	247	Component Inspection (Crankshaft Position sen-	
Component Inspection .....	250	sor) .....	300
<b>P0139 HO2S2</b> .....	<b>252</b>	<b>P0340 CMP SENSOR (PHASE)</b> .....	<b>301</b>
DTC Description .....	252	DTC Description .....	301
Diagnosis Procedure .....	254	Diagnosis Procedure .....	301
Component Inspection .....	256	Component Inspection (Camshaft position sen-	
<b>P014C, P014D, P015A, P015B, A/F SENSOR</b>		sor) .....	303
<b>1</b> .....	<b>258</b>	<b>P0420 THREE WAY CATALYST FUNCTION..</b>	<b>304</b>
DTC Description .....	258	DTC Description .....	304
Diagnosis Procedure .....	260	Diagnosis Procedure .....	305
<b>P0171 FUEL INJECTION SYSTEM FUNC-</b>		<b>P0441 EVAP CONTROL SYSTEM</b> .....	<b>309</b>
<b>TION</b> .....	<b>263</b>	DTC Description .....	309
DTC Description .....	263	Diagnosis Procedure .....	311
Diagnosis Procedure .....	264	<b>P0443 EVAP CANISTER PURGE VOLUME</b>	
<b>P0172 FUEL INJECTION SYSTEM FUNC-</b>		<b>CONTROL SOLENOID VALVE</b> .....	<b>314</b>
<b>TION</b> .....	<b>268</b>	DTC Description .....	314
DTC Description .....	268	Diagnosis Procedure .....	315
Diagnosis Procedure .....	269	Component Inspection .....	318
<b>P0181 FTT SENSOR</b> .....	<b>273</b>	<b>P0444, P0445 EVAP CANISTER PURGE</b>	
DTC Description .....	273	<b>VOLUME CONTROL SOLENOID VALVE</b> .....	<b>319</b>
Diagnosis Procedure .....	275	DTC Description .....	319
Component Inspection .....	276	Diagnosis Procedure .....	319
		Component Inspection .....	321

<b>P0447 EVAP CANISTER VENT CONTROL VALVE</b> .....	<b>322</b>	<b>P050A, P050B, P050E COLD START CONTROL</b> .....	<b>359</b>	A
DTC Description .....	322	Description .....	359	
Diagnosis Procedure .....	322	DTC Description .....	359	
Component Inspection .....	324	Diagnosis Procedure .....	360	EC
<b>P0448 EVAP CANISTER VENT CONTROL VALVE</b> .....	<b>326</b>	<b>P0520 EOP SENSOR</b> .....	<b>361</b>	
DTC Description .....	326	DTC Description .....	361	C
Diagnosis Procedure .....	327	Diagnosis Procedure .....	361	
Component Inspection .....	328	Component Inspection .....	363	
<b>P0451 EVAP CONTROL SYSTEM PRES-SURE SENSOR</b> .....	<b>330</b>	<b>P0524 ENGINE OIL PRESSURE</b> .....	<b>364</b>	D
DTC Description .....	330	DTC Description .....	364	
Diagnosis Procedure .....	331	Diagnosis Procedure .....	365	E
Component Inspection .....	333	Component Inspection .....	366	
<b>P0452 EVAP CONTROL SYSTEM PRES-SURE SENSOR</b> .....	<b>334</b>	<b>P052A, P052B INTAKE VALVE TIMING CONTROL</b> .....	<b>367</b>	F
DTC Description .....	334	DTC Description .....	367	
Diagnosis Procedure .....	335	Diagnosis Procedure .....	368	G
Component Inspection .....	336	Component Inspection (Intake Valve Timing Control Solenoid Valve) .....	369	
<b>P0453 EVAP CONTROL SYSTEM PRES-SURE SENSOR</b> .....	<b>337</b>	Component Inspection (Intake Valve Timing Intermediate Lock Control Solenoid Valve) .....	370	H
DTC Description .....	337	Component Inspection (Crankshaft Position sensor) .....	371	
Diagnosis Procedure .....	338	Component Inspection (Camshaft position sensor) .....	371	I
Component Inspection .....	340	<b>P0603, P062F ECM</b> .....	<b>373</b>	J
<b>P0456 EVAP CONTROL SYSTEM</b> .....	<b>341</b>	DTC Description .....	373	
DTC Description .....	341	Diagnosis Procedure .....	374	K
Diagnosis Procedure .....	342	<b>P0604 ECM</b> .....	<b>375</b>	
Component Inspection .....	346	DTC Description .....	375	L
<b>P0460 FUEL LEVEL SENSOR</b> .....	<b>347</b>	Diagnosis Procedure .....	375	
DTC Description .....	347	<b>P0605 ECM</b> .....	<b>376</b>	M
Diagnosis Procedure .....	347	DTC Description .....	376	
<b>P0461 FUEL LEVEL SENSOR</b> .....	<b>349</b>	Diagnosis Procedure .....	376	N
DTC Description .....	349	<b>P0606 ECM</b> .....	<b>377</b>	
Diagnosis Procedure .....	350	DTC Description .....	377	O
<b>P0462, P0463 FUEL LEVEL SENSOR</b> .....	<b>351</b>	Diagnosis Procedure .....	377	
DTC Description .....	351	<b>P0607 ECM</b> .....	<b>379</b>	P
Diagnosis Procedure .....	351	DTC Description .....	379	
<b>P0500 VSS</b> .....	<b>353</b>	Diagnosis Procedure .....	379	
Description .....	353	<b>P060A ECM</b> .....	<b>380</b>	
DTC Description .....	353	DTC Description .....	380	
Diagnosis Procedure .....	354	Diagnosis Procedure .....	380	
<b>P0506 ISC SYSTEM</b> .....	<b>355</b>	<b>P060B ECM</b> .....	<b>381</b>	
Description .....	355	DTC Description .....	381	
DTC Description .....	355	Diagnosis Procedure .....	381	
Diagnosis Procedure .....	356	<b>P0643 SENSOR POWER SUPPLY</b> .....	<b>382</b>	
<b>P0507 ISC SYSTEM</b> .....	<b>357</b>	Description .....	382	
Description .....	357	DTC Description .....	382	
DTC Description .....	357	Diagnosis Procedure .....	383	
Diagnosis Procedure .....	358			

<b>P0850 PNP SWITCH</b> .....	<b>385</b>	DTC Description .....	419
Description .....	385	Diagnosis Procedure .....	419
DTC Description .....	385		
Diagnosis Procedure .....	386		
<b>P1078 EVT CONTROL POSITION SENSOR</b> .....	<b>388</b>	<b>P1805 BRAKE SWITCH</b> .....	<b>421</b>
DTC Description .....	388	DTC Description .....	421
Diagnosis Procedure .....	388	Diagnosis Procedure .....	421
Component Inspection .....	390	Component Inspection (Stop Lamp Switch) .....	422
<b>P1148 CLOSED LOOP CONTROL</b> .....	<b>391</b>	<b>P2004 INTAKE MANIFOLD RUNNER CON- TROL VALVE</b> .....	<b>423</b>
DTC Description .....	391	DTC Description .....	423
Diagnosis Procedure .....	391	Diagnosis Procedure .....	423
		Component Inspection .....	424
<b>P117A AIR FUEL RATIO</b> .....	<b>392</b>	<b>P2014, P2016, P2017, P2018 INTAKE MANI- FOLD RUNNER CONTROL VALVE POSI- TION SENSOR</b> .....	<b>426</b>
DTC Description .....	392	DTC Description .....	426
Diagnosis Procedure .....	393	Diagnosis Procedure .....	427
<b>P1212 TCS COMMUNICATION LINE</b> .....	<b>398</b>	<b>P2096, P2097 A/F SENSOR 1</b> .....	<b>429</b>
Description .....	398	DTC Description .....	429
DTC Description .....	398	Diagnosis Procedure .....	429
Diagnosis Procedure .....	398		
<b>P1217 ENGINE OVER TEMPERATURE</b> .....	<b>400</b>	<b>P2100, P2103 THROTTLE CONTROL MO- TOR RELAY</b> .....	<b>433</b>
DTC Description .....	400	DTC Description .....	433
Diagnosis Procedure .....	401	Diagnosis Procedure .....	434
<b>P1225 TP SENSOR</b> .....	<b>403</b>	<b>P2101 ELECTRIC THROTTLE CONTROL FUNCTION</b> .....	<b>436</b>
DTC Description .....	403	DTC Description .....	436
Diagnosis Procedure .....	403	Diagnosis Procedure .....	436
		Component Inspection .....	438
<b>P1226 TP SENSOR</b> .....	<b>404</b>	<b>P2118 THROTTLE CONTROL MOTOR</b> .....	<b>439</b>
DTC Description .....	404	DTC Description .....	439
Diagnosis Procedure .....	404	Diagnosis Procedure .....	439
		Component Inspection .....	440
<b>P155D GENERATOR</b> .....	<b>405</b>	<b>P2119 ELECTRIC THROTTLE CONTROL ACTUATOR</b> .....	<b>441</b>
DTC Description .....	405	DTC Description .....	441
Diagnosis Procedure .....	405	Diagnosis Procedure .....	441
<b>P1564 ASCD STEERING SWITCH</b> .....	<b>406</b>	<b>P2122, P2123 APP SENSOR</b> .....	<b>443</b>
DTC Description .....	406	DTC Description .....	443
Diagnosis Procedure .....	406	Diagnosis Procedure .....	443
Component Inspection .....	408	Component Inspection .....	445
<b>P1568 SIGNAL INVALID</b> .....	<b>409</b>	<b>P2127, P2128 APP SENSOR</b> .....	<b>446</b>
DTC Description .....	409	DTC Description .....	446
Diagnosis Procedure .....	409	Diagnosis Procedure .....	446
		Component Inspection .....	447
<b>P1572 BRAKE PEDAL POSITION SWITCH</b> ..	<b>411</b>	<b>P2135 TP SENSOR</b> .....	<b>449</b>
DTC Description .....	411	DTC Description .....	449
Diagnosis Procedure .....	412	Diagnosis Procedure .....	449
Component Inspection (Brake Pedal Position Switch) .....	414	Component Inspection .....	451
Component Inspection (Stop Lamp Switch) .....	415	<b>P2138 APP SENSOR</b> .....	<b>452</b>
<b>P1574 ASCD VEHICLE SPEED SENSOR</b> .....	<b>417</b>		
Description .....	417		
DTC Description .....	417		
Diagnosis Procedure .....	418		
<b>P1715 INPUT SPEED SENSOR</b> .....	<b>419</b>		
Description .....	419		

DTC Description .....	452	Component Function Check .....	480	
Diagnosis Procedure .....	452	Diagnosis Procedure .....	480	A
Component Inspection .....	454	Component Inspection .....	482	
<b>P2610 ECM INTERNAL TIMER .....</b>	<b>456</b>	<b>REFRIGERANT PRESSURE SENSOR .....</b>	<b>485</b>	<b>EC</b>
Description .....	456	Component Function Check .....	485	
DTC Description .....	456	Diagnosis Procedure .....	485	
Diagnosis Procedure .....	457	<b>SENSOR POWER SUPPLY2 CIRCUIT .....</b>	<b>487</b>	<b>C</b>
<b>BRAKE PEDAL POSITION SWITCH .....</b>	<b>458</b>	Description .....	487	
Component Function Check .....	458	Diagnosis Procedure .....	487	
Diagnosis Procedure .....	458	<b>SYMPTOM DIAGNOSIS .....</b>	<b>489</b>	<b>D</b>
Component Inspection (Brake Pedal Position Switch) .....	459	<b>ENGINE CONTROL SYSTEM .....</b>	<b>489</b>	<b>E</b>
<b>COOLING FAN .....</b>	<b>461</b>	Symptom Table .....	489	
Component Function Check .....	461	<b>INFORMATION DISPLAY IS MALFUNCTION- ING .....</b>	<b>494</b>	<b>F</b>
Diagnosis Procedure .....	461	Diagnosis Procedure .....	494	
Component Inspection (Cooling Fan Motor) .....	464	<b>NORMAL OPERATING CONDITION .....</b>	<b>495</b>	<b>G</b>
Component Inspection (Cooling Fan Relay) .....	464	Description .....	495	
<b>ELECTRICAL LOAD SIGNAL .....</b>	<b>465</b>	<b>PERIODIC MAINTENANCE .....</b>	<b>496</b>	<b>H</b>
Description .....	465	<b>IDLE SPEED .....</b>	<b>496</b>	
Component Function Check .....	465	Inspection .....	496	
Diagnosis Procedure .....	465	<b>IGNITION TIMING .....</b>	<b>497</b>	<b>I</b>
Component Inspection .....	465	Inspection .....	497	
<b>FUEL INJECTOR .....</b>	<b>467</b>	<b>EVAPORATIVE EMISSION SYSTEM .....</b>	<b>498</b>	<b>J</b>
Component Function Check .....	467	Inspection .....	498	
Diagnosis Procedure .....	467	<b>EVAP LEAK CHECK .....</b>	<b>499</b>	<b>K</b>
Component Inspection .....	468	Inspection .....	499	
<b>FUEL PUMP .....</b>	<b>470</b>	<b>POSITIVE CRANKCASE VENTILATION .....</b>	<b>501</b>	<b>L</b>
Description .....	470	Inspection .....	501	
Component Function Check .....	470	<b>REMOVAL AND INSTALLATION .....</b>	<b>502</b>	<b>M</b>
Diagnosis Procedure .....	470	<b>ECM .....</b>	<b>502</b>	
Component Inspection .....	472	Removal and Installation .....	502	
<b>IGNITION SIGNAL .....</b>	<b>473</b>	<b>SERVICE DATA AND SPECIFICATIONS (SDS) .....</b>	<b>503</b>	<b>N</b>
Component Function Check .....	473	<b>SERVICE DATA AND SPECIFICATIONS (SDS) .....</b>	<b>503</b>	<b>O</b>
Diagnosis Procedure .....	473	Idle Speed .....	503	
Component Inspection (Ignition Coil with Power Transistor) .....	476	Ignition Timing .....	503	
Component Inspection (Condenser) .....	477	Calculated Load Value .....	503	
<b>INFORMATION DISPLAY (ASCD) .....</b>	<b>478</b>	Mass Air Flow Sensor .....	503	<b>P</b>
Component Function Check .....	478			
Diagnosis Procedure .....	478			
<b>MALFUNCTION INDICATOR LAMP .....</b>	<b>479</b>			
Component Function Check .....	479			
Diagnosis Procedure .....	479			
<b>ON BOARD REFUELING VAPOR RECOV- ERY (ORVR) .....</b>	<b>480</b>			

## PRECAUTION

### PRECAUTIONS

#### Precaution for Supplemental Restraint System (SRS) "AIR BAG" and "SEAT BELT PRE-TENSIONER"

INFOID:000000011277813

The Supplemental Restraint System such as "AIR BAG" and "SEAT BELT PRE-TENSIONER", used along with a front seat belt, helps to reduce the risk or severity of injury to the driver and front passenger for certain types of collision. Information necessary to service the system safely is included in the SR and SB section of this Service Manual.

**WARNING:**

- To avoid rendering the SRS inoperative, which could increase the risk of personal injury or death in the event of a collision which would result in air bag inflation, all maintenance must be performed by an authorized NISSAN/INFINITI dealer.
- Improper maintenance, including incorrect removal and installation of the SRS, can lead to personal injury caused by unintentional activation of the system. For removal of Spiral Cable and Air Bag Module, see the SR section.
- Do not use electrical test equipment on any circuit related to the SRS unless instructed to in this Service Manual. SRS wiring harnesses can be identified by yellow and/or orange harnesses or harness connectors.

#### PRECAUTIONS WHEN USING POWER TOOLS (AIR OR ELECTRIC) AND HAMMERS

**WARNING:**

- When working near the Airbag Diagnosis Sensor Unit or other Airbag System sensors with the Ignition ON or engine running, DO NOT use air or electric power tools or strike near the sensor(s) with a hammer. Heavy vibration could activate the sensor(s) and deploy the air bag(s), possibly causing serious injury.
- When using air or electric power tools or hammers, always switch the Ignition OFF, disconnect the battery and wait at least three minutes before performing any service.

#### Precaution for Procedure without Cowl Top Cover

INFOID:000000011277814

When performing the procedure after removing cowl top cover, cover the lower end of windshield with urethane, etc to prevent damage to windshield.

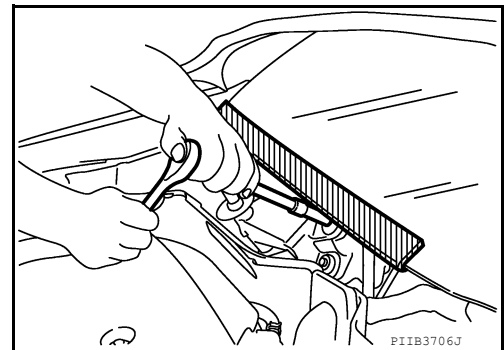

#### On Board Diagnostic (OBD) System of Engine and CVT

INFOID:000000011277815

The ECM has an on board diagnostic system. It will light up the malfunction indicator lamp (MIL) to warn the driver of a malfunction causing emission deterioration.

**CAUTION:**

- Be sure to turn the ignition switch OFF and disconnect the negative battery cable before any repair or inspection work. The open/short circuit of related switches, sensors, solenoid valves, etc. will cause the MIL to light up.
- Be sure to connect and lock the connectors securely after work. A loose (unlocked) connector will cause the MIL to light up due to the open circuit. (Be sure the connector is free from water, grease, dirt, bent terminals, etc.)
- Certain systems and components, especially those related to OBD, may use a new style slide-locking type harness connector. For description and how to disconnect, refer to [PG-7. "Harness Connector"](#).
- Be sure to route and secure the harnesses properly after work. The interference of the harness with a bracket, etc. may cause the MIL to light up due to the short circuit.



# PRECAUTIONS

[QR25DE]

## < PRECAUTION >

- Be sure to connect rubber tubes properly after work. A misconnected or disconnected rubber tube may cause the MIL to light up due to the malfunction of the EVAP system or fuel injection system, etc.
- Be sure to erase the unnecessary malfunction information (repairs completed) from the ECM and TCM (Transmission control module) before returning the vehicle to the customer.

## General Precautions

INFOID:000000011277816

- Always use a 12 volt battery as power source.
- Do not attempt to disconnect battery cables while engine is running.
- Before connecting or disconnecting the ECM harness connector, turn ignition switch OFF and disconnect negative battery cable. Failure to do so may damage the ECM because battery voltage is applied to ECM even if ignition switch is turned OFF.
- Before removing parts, turn ignition switch OFF and then disconnect battery ground cable.

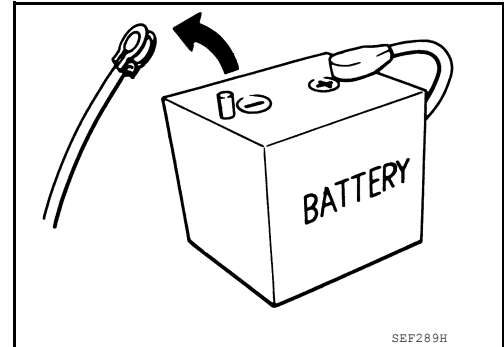

- Do not disassemble ECM.
- If a battery cable is disconnected, the memory will return to the ECM value. The ECM will now start to self-control at its initial value. Engine operation can vary slightly when the terminal is disconnected. However, this is not an indication of a malfunction. Do not replace parts because of a slight variation.
- If the battery is disconnected, the following emission-related diagnostic information will be lost within 24 hours.

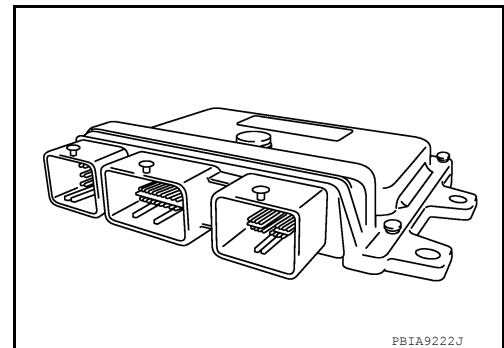

- Diagnostic trouble codes
- 1st trip diagnostic trouble codes
- Freeze frame data
- 1st trip freeze frame data
- System readiness test (SRT) codes
- Test values

- When connecting ECM harness connector<sup>①</sup>, fasten<sup>Ⓑ</sup> it securely with a lever as far as it will go as shown in the figure.

- ② ECM
- Ⓑ Loosen

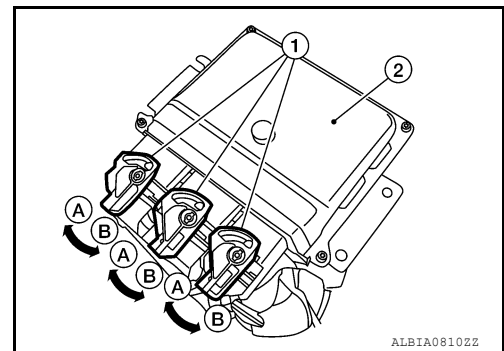

- When connecting or disconnecting pin connectors into or from ECM, take care not to damage pin terminals (bend or break). Make sure that there are not any bends or breaks on ECM pin terminal, when connecting pin connectors.
- Securely connect ECM harness connectors. A poor connection can cause an extremely high (surge) voltage to develop in coil and condenser, thus resulting in damage to ICs.
- Keep engine control system harness at least 10 cm (4 in) away from adjacent harness, to prevent engine control system malfunctions due to receiving external noise, degraded operation of ICs, etc.

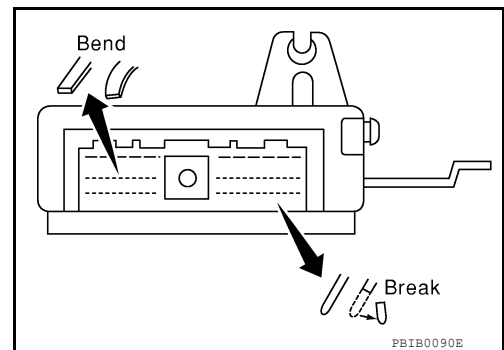

# PRECAUTIONS

[QR25DE]

## < PRECAUTION >

- Keep engine control system parts and harness dry.
- Before replacing ECM, perform ECM Terminals and Reference Value inspection and make sure ECM functions properly. Refer to **EC-80, "Reference Value"**.
- Handle mass air flow sensor carefully to avoid damage.
- Do not clean mass air flow sensor with any type of detergent.
- Do not disassemble electric throttle control actuator.
- Even a slight leak in the air intake system can cause serious incidents.
- Do not shock or jar the camshaft position sensor (PHASE), crankshaft position sensor (POS).

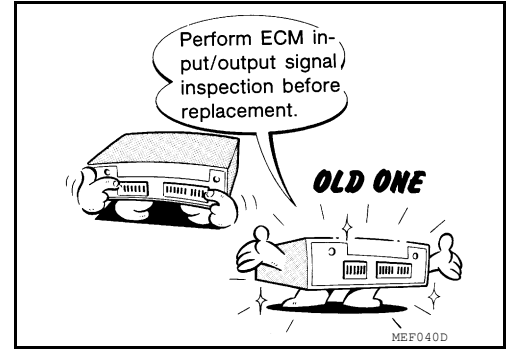

- After performing each TROUBLE DIAGNOSIS, perform DTC CONFIRMATION PROCEDURE or Component Function Check. The DTC should not be displayed in the DTC Confirmation Procedure if the repair is completed. The Component Function Check should be a good result if the repair is completed.

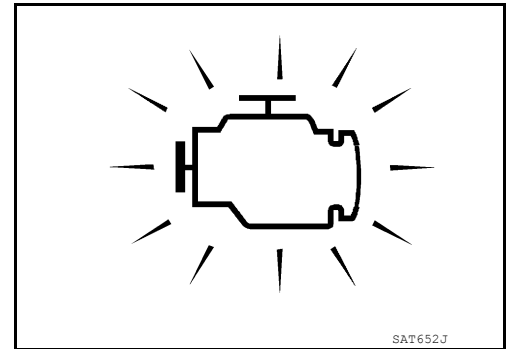

- When measuring ECM signals with a circuit tester, never allow the two tester probes to contact. Accidental contact of probes will cause a short circuit and damage the ECM power transistor.

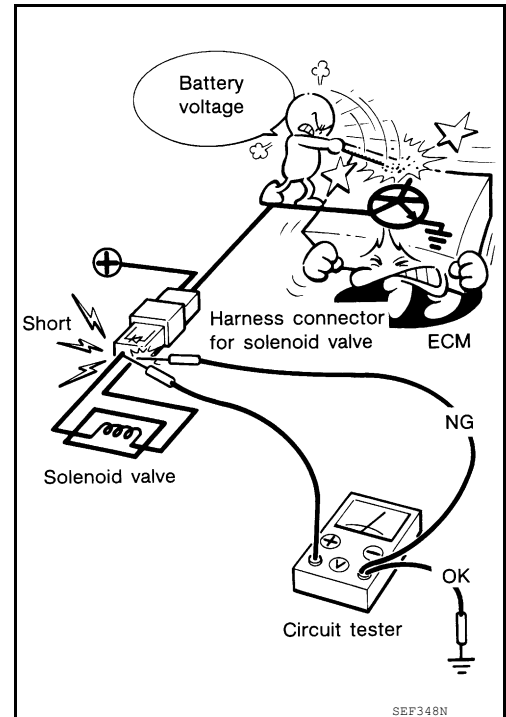

- Do not operate fuel pump when there is no fuel in lines.
- Tighten fuel hose clamps to the specified torque.

# PRECAUTIONS

[QR25DE]

## < PRECAUTION >

- Do not depress accelerator pedal when starting.
- Immediately after starting, do not rev up engine unnecessarily.
- Do not rev up engine just prior to shutdown.



- When installing C.B. ham radio or a mobile phone, be sure to observe the following as it may adversely affect electronic control systems depending on installation location.
  - Keep the antenna as far as possible from the electronic control units.
  - Keep the antenna feeder line more than 20 cm (8 in) away from the harness of electronic controls. Do not let them run parallel for a long distance.
  - Adjust the antenna and feeder line so that the standing-wave ratio can be kept smaller.
  - Be sure to ground the radio to vehicle body.

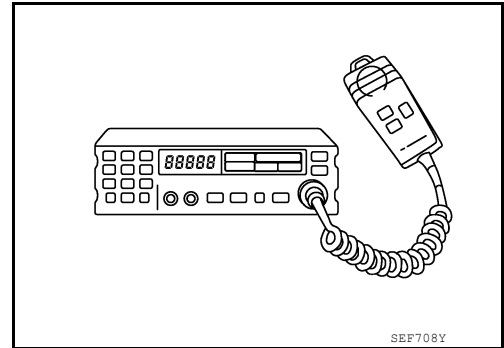

A

EC

C

D

E

F

G

H

I

J

K

L

M

N

O

P

# PREPARATION

< PREPARATION >

[QR25DE]

## PREPARATION

### PREPARATION

#### Special Service Tools

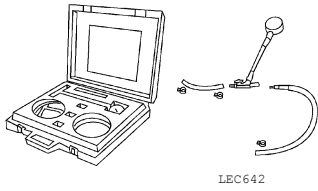
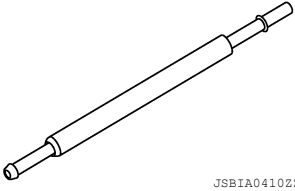

INFOID:000000011277817

The actual shape of the tools may differ from those illustrated here.

Tool number (TechMate No.) Tool name	Description
<p>— (J-44321) Fuel pressure gauge kit</p>  <p style="text-align: center;">LEC642</p>	Checks fuel pressure
<p>KV10120000 ( — ) Fuel tube adapter</p>  <p style="text-align: center;">JSBIA04102Z</p>	Measures fuel pressure

#### Commercial Service Tools

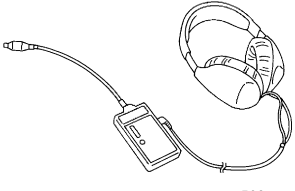
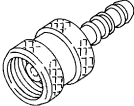

INFOID:000000011277818

Tool name (TechMate No.)	Description
<p>Leak detector i.e.: (J-41416)</p>  <p style="text-align: center;">S-NT703</p>	Locates the EVAP leak
<p>EVAP service port adapter i.e.: (J-41413-OBID)</p>  <p style="text-align: center;">S-NT704</p>	Applies positive pressure through EVAP service port
<p>Fuel filler cap adapter i.e.: (MLR-8382)</p>  <p style="text-align: center;">S-NT815</p>	Checks fuel tank vacuum relief valve opening pressure

# PREPARATION

< PREPARATION >

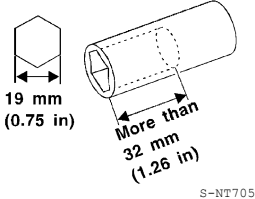
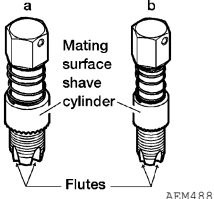
[QR25DE]

Tool name (TechMate No.)	Description	A
<p>Socket wrench i.e.: ( — )</p> 	<p>Removes and installs engine coolant temperature sensor</p>	<p>EC</p>
<p>Oxygen sensor thread cleaner i.e.: (J-43897-18) (J-43897-12)</p> 	<p>Reconditions the exhaust system threads before installing a new oxygen sensor. Use with anti-seize lubricant shown below. <b>a: 18 mm diameter with pitch 1.5 mm for Zirconia Oxygen Sensor</b> <b>b: 12 mm diameter with pitch 1.25 mm for Titanium Oxygen Sensor</b></p>	<p>D</p>
<p>Anti-seize lubricant i.e.: (Permatex™ 133AR or equivalent meeting MIL specification MIL-A-907)</p> 	<p>Lubricates oxygen sensor thread cleaning tool when reconditioning exhaust system threads.</p>	<p>F</p>

C

D

E

F

G

H

I

J

K

L

M

N

O

P

# COMPONENT PARTS

< SYSTEM DESCRIPTION >

[QR25DE]

## SYSTEM DESCRIPTION

### COMPONENT PARTS

#### Component Parts Location

INFOID:000000011277819

#### ENGINE ROOM COMPARTMENT

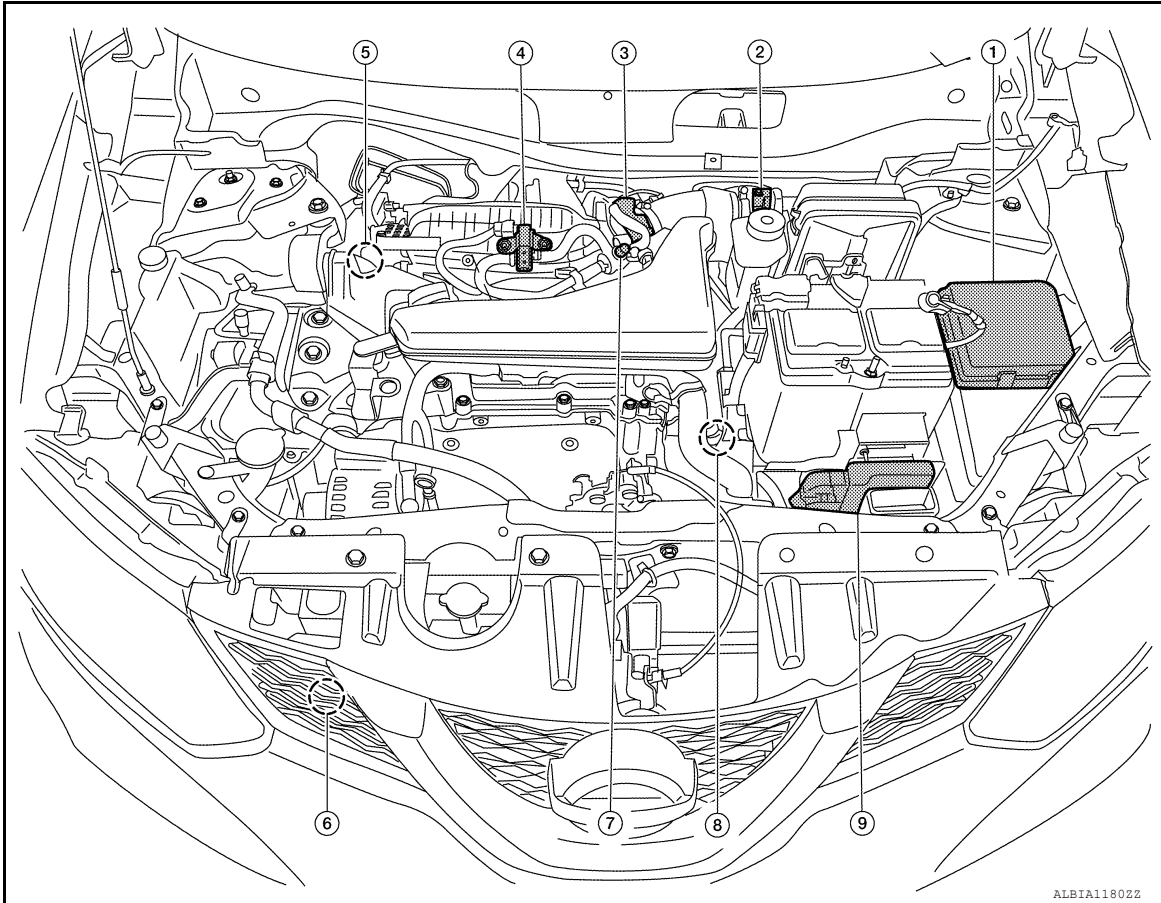

No.	Component	Function
①	IPDM E/R	<ul style="list-style-type: none"> <li>• IPDM E/R control the internal relays and the actuators.</li> <li>- Refer to <a href="#">PCS-7, "RELAY CONTROL SYSTEM : System Description"</a>.</li> <li>• When CAN communication with ECM is impossible, IPDM E/R performs fail-safe control.</li> <li>- Refer to <a href="#">PCS-8, "RELAY CONTROL SYSTEM : Fail-safe"</a>.</li> </ul>
②	Mass air flow sensor (with intake air temperature sensor)	<a href="#">EC-21, "Mass Air Flow Sensor (With Intake Air Temperature Sensor)"</a>
③	Electric throttle control actuator (with built in throttle position sensor and throttle control motor)	<a href="#">EC-19, "Electric Throttle Control Actuator"</a>
④	EVAP canister purge volume control solenoid valve	<a href="#">EC-27, "EVAP Canister Purge Volume Control Solenoid Valve"</a>
⑤	Intake manifold runner control valve actuator	<a href="#">EC-24, "Intake Manifold Runner Control Valve"</a>
⑥	Refrigerant pressure sensor	<a href="#">EC-28, "Refrigerant Pressure Sensor"</a>
⑦	EVAP service port	<p>When perform the EVAP leak check, positive pressure is delivered to the EVAP system through the EVAP service port.</p> <p>Refer to <a href="#">EC-499, "Inspection"</a>.</p>

# COMPONENT PARTS

< SYSTEM DESCRIPTION >

[QR25DE]

No.	Component	Function
⑧	Transmission range switch	<ul style="list-style-type: none"> <li>The transmission range switch is installed to upper part of transaxle case.</li> <li>ECM detects the selector lever position because the continuity of the transmission range switch line (the ON) exists.</li> </ul>
⑨	ECM	<a href="#">EC-18, "ECM"</a>

## ENGINE COMPARTMENT

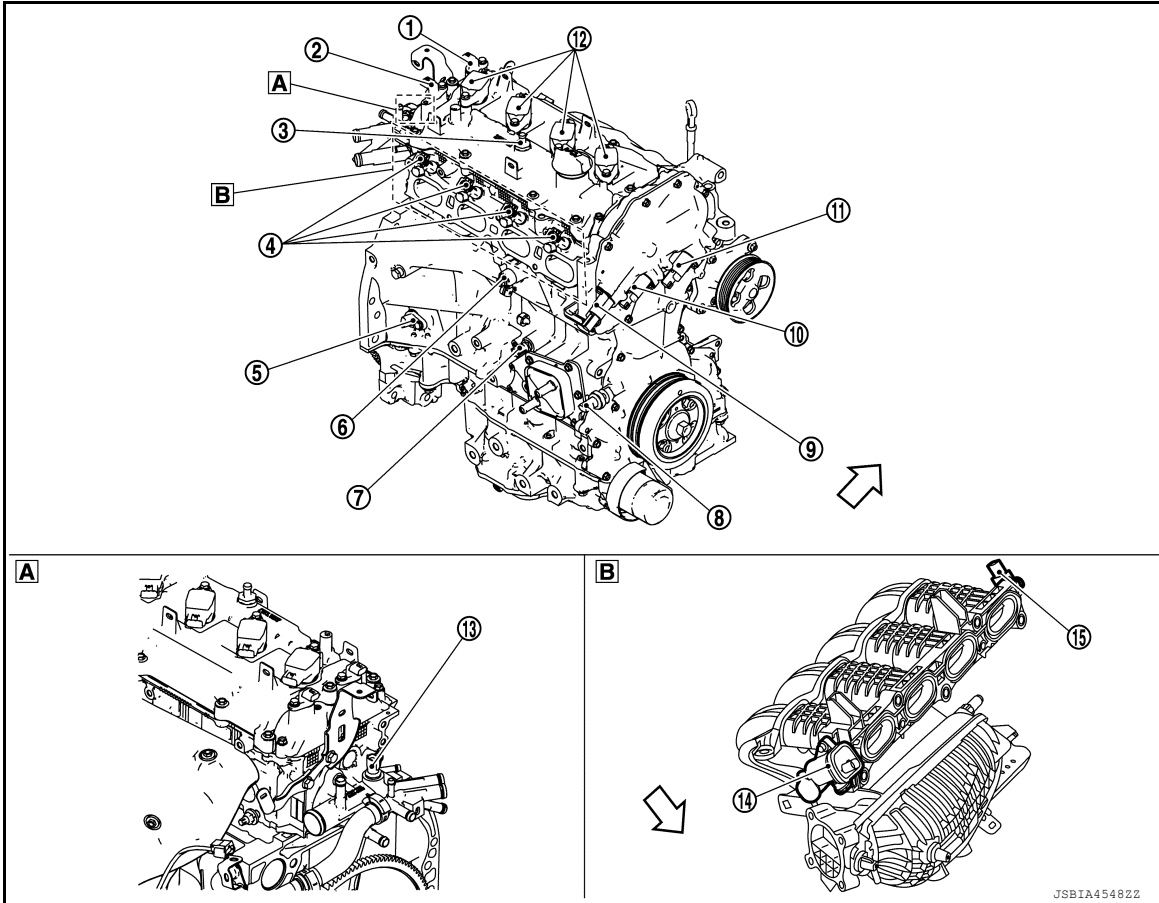

**A** Engine rear side

**B** Intake side

← : Vehicle front

No.	Component	Function
①	Exhaust valve timing control position sensor	<a href="#">EC-23, "Exhaust Valve Timing Control Position Sensor"</a>
②	Camshaft position sensor (PHASE)	<a href="#">EC-22, "Camshaft Position Sensor (PHASE)"</a>
③	PCV valve	The positive crankcase ventilation (PCV) valve is provided to conduct crankcase blow-by gas to the intake manifold.
④	Fuel injector	<a href="#">EC-20, "Fuel Injector"</a>
⑤	Crankshaft position sensor (POS)	<a href="#">EC-22, "Crankshaft Position Sensor (POS)"</a>
⑥	Knock sensor	<a href="#">EC-25, "Knock Sensor"</a>
⑦	Engine oil temperature sensor	<a href="#">EC-26, "Engine Oil Temperature Sensor"</a>
⑧	Engine oil pressure sensor	<a href="#">EC-26, "Engine Oil Pressure Sensor"</a>

# COMPONENT PARTS

< SYSTEM DESCRIPTION >

[QR25DE]

No.	Component	Function
⑨	Intake valve timing intermediate lock control solenoid valve	<a href="#">EC-23, "Intake Valve Timing Intermediate Lock Control Solenoid Valve"</a>
⑩	Intake valve timing control solenoid valve	<a href="#">EC-23, "Intake Valve Timing Control Solenoid Valve"</a>
⑪	Exhaust valve timing control solenoid valve	<a href="#">EC-24, "Exhaust Valve Timing Control Solenoid Valve"</a>
⑫	Ignition coil (with power transistor)	<a href="#">EC-19, "Ignition Coil With Power Transistor"</a>
⑬	Engine coolant temperature sensor	<a href="#">EC-21, "Engine Coolant Temperature Sensor"</a>
⑭	Intake manifold runner control valve position sensor	<a href="#">EC-24, "Intake Manifold Runner Control Valve"</a>
⑮	Intake manifold runner control valve actuator	

## EXHAUST COMPARTMENT

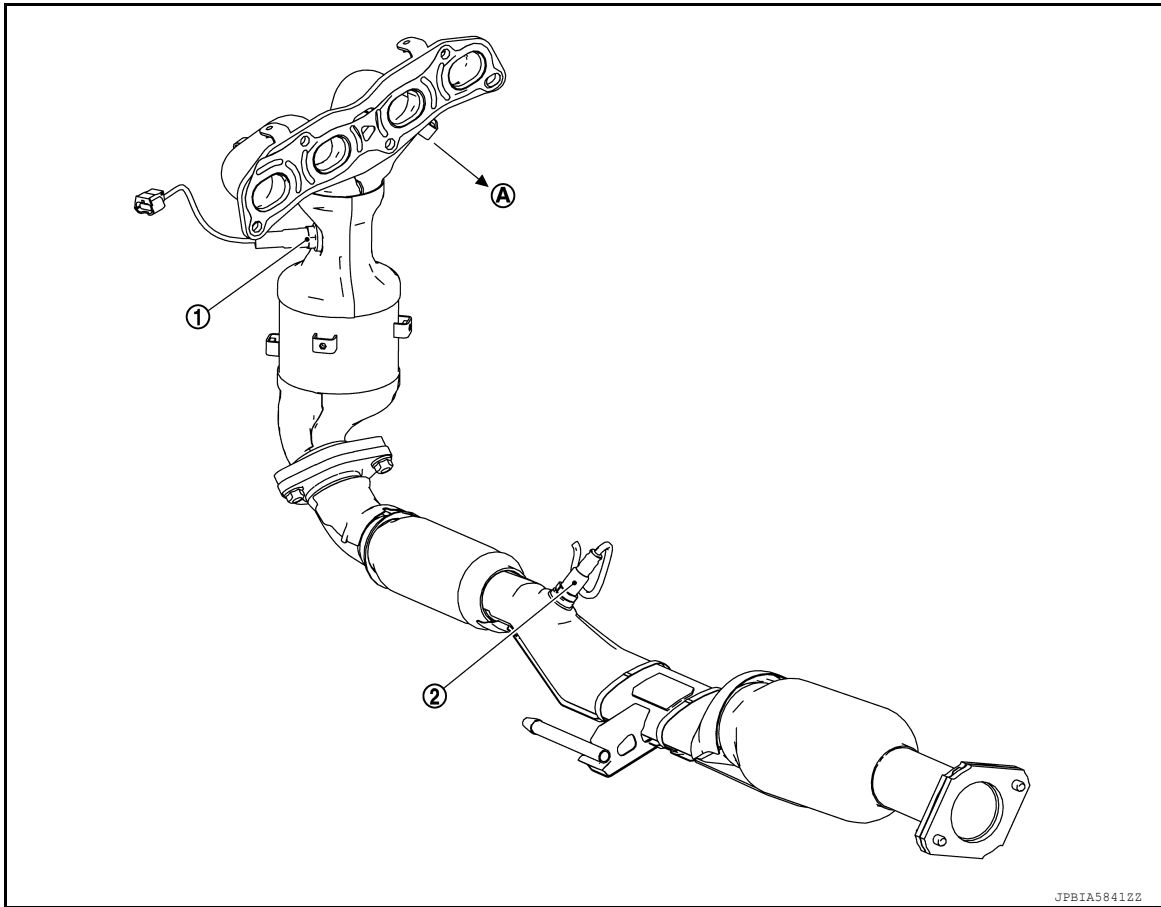

Ⓐ To engine assembly

No.	Component	Function
①	Air fuel ratio (A/F) sensor 1	<a href="#">EC-24, "Air Fuel Ratio (A/F) Sensor 1"</a>
②	Heated oxygen sensor 2	<a href="#">EC-25, "Heated Oxygen Sensor 2"</a>

## BODY COMPARTMENT



# COMPONENT PARTS

< SYSTEM DESCRIPTION >

[QR25DE]

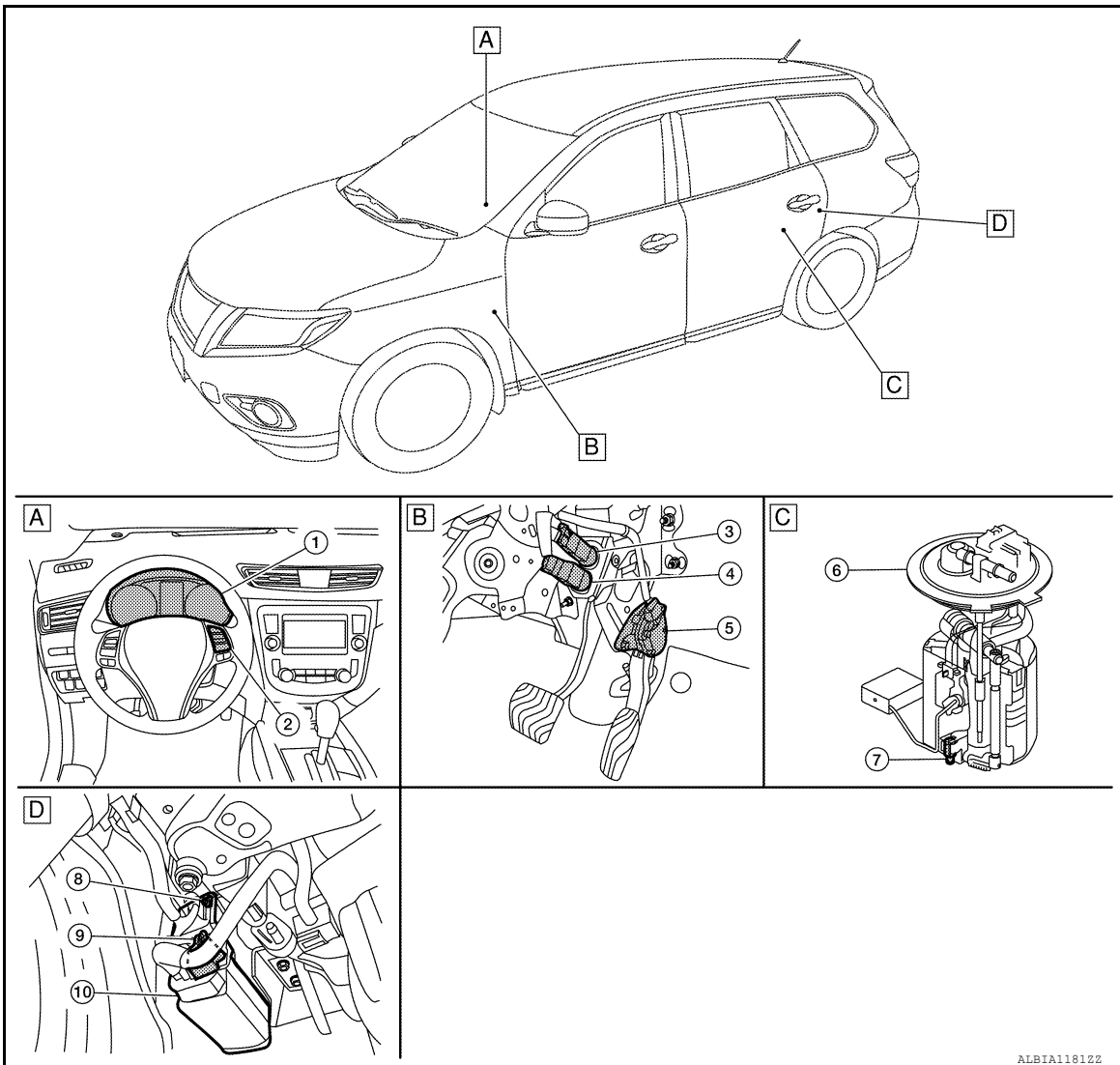

**A** Instrument panel area

**B** Periphery of pedals

**C** Inside fuel tank area

**D** Behind fuel tank

↶ : Vehicle front

No.	Component		Function
①	Combination meter	Malfunction indicator lamp (MIL)	<a href="#">EC-51. "WARNING/INDICATOR/CHIME LIST : Malfunction Indicator Lamp (MIL)"</a>
		Information display	<a href="#">EC-28. "Information Display"</a>
②	ASCD steering switch		<a href="#">EC-28. "ASCD Steering Switch"</a>
③	Stop lamp switch		<a href="#">EC-28. "Stop Lamp Switch &amp; Brake Pedal Position Switch"</a>
④	Brake pedal position switch		
⑤	Accelerator pedal position sensor		<a href="#">EC-18. "Accelerator Pedal Position Sensor"</a>
⑥	Fuel level sensor unit and fuel pump		<a href="#">EC-20. "Fuel Level Sensor Unit and Fuel Pump"</a>
⑦	Fuel tank temperature sensor		<a href="#">EC-20. "Fuel Tank Temperature Sensor"</a>
⑧	EVAP control system pressure sensor		<a href="#">EC-27. "EVAP Control System Pressure Sensor"</a>

# COMPONENT PARTS

< SYSTEM DESCRIPTION >

[QR25DE]

No.	Component	Function
⑨	EVAP canister vent control valve	EC-27, "EVAP Canister Vent Control Valve"
⑩	EVAP canister	EC-27, "EVAP Canister"

## ECM

INFOID:000000011277820

The ECM consists of a microcomputer and connectors for signal input and output and for power supply. The ECM controls the engine.

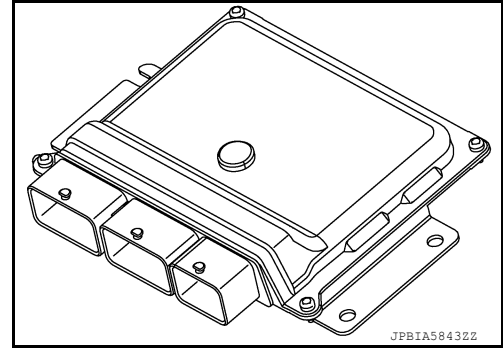

## Accelerator Pedal Position Sensor

INFOID:000000011277821

The accelerator pedal position sensor is installed on the upper end of the accelerator pedal assembly. The sensor detects the accelerator position and sends a signal to the ECM.

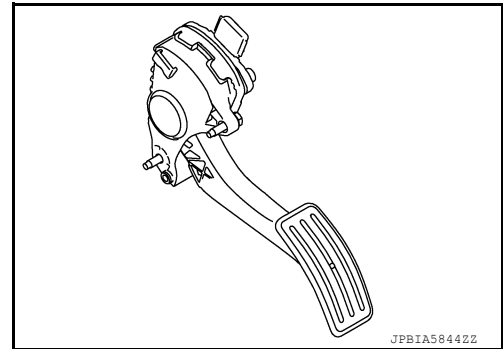

Accelerator pedal position sensor has two sensors. These sensors are a kind of potentiometers which transform the accelerator pedal position into output voltage, and emit the voltage signal to the ECM. In addition, these sensors detect the opening and closing speed of the accelerator pedal and feed the voltage signals to the ECM. The ECM judges the current opening angle of the accelerator pedal from these signals and controls the throttle control motor based on these signals.

Idle position of the accelerator pedal is determined by the ECM receiving the signal from the accelerator pedal position sensor. The ECM uses this signal for the engine operation such as fuel cut.

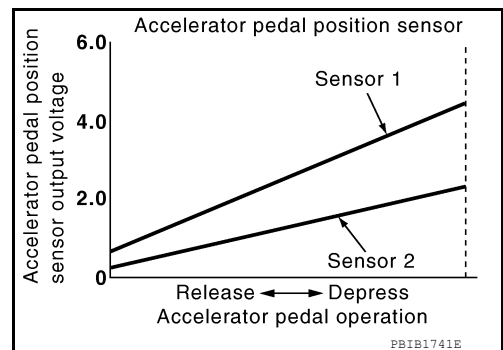

Electric Throttle Control Actuator

INFOID:000000011277822

Electric throttle control actuator consists of throttle body, throttle valve, throttle control motor and throttle position sensor.

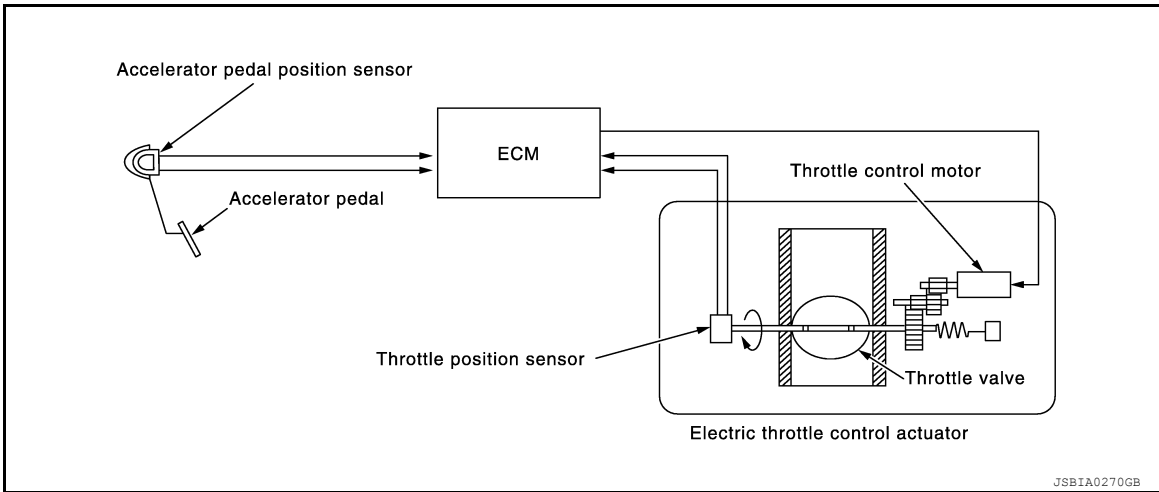

THROTTLE CONTROL MOTOR RELAY

Power supply for the throttle control motor is provided to the ECM via throttle control motor relay. The throttle control motor relay is ON/OFF controlled by the ECM. When the ignition switch is turned ON, the ECM sends an ON signal to throttle control motor relay and battery voltage is provided to the ECM. When the ignition switch is turned OFF, the ECM sends an OFF signal to throttle control motor relay and battery voltage is not provided to the ECM.

THROTTLE CONTROL MOTOR

The throttle control motor is operated by the ECM and it opens and closes the throttle valve. The current opening angle of the throttle valve is detected by the throttle position sensor and it provides feedback to the ECM to control the throttle control motor to make the throttle valve opening angle properly in response to driving condition.

THROTTLE POSITION SENSOR

The throttle position sensor responds to the throttle valve movement. The throttle position sensor has two sensors. These sensors are a kind of potentiometers which transform the throttle valve position into output voltage, and emit the voltage signal to the ECM. In addition, these sensors detect the opening and closing speed of the throttle valve and feed the voltage signals to the ECM. The ECM judges the current opening angle of the throttle valve from these signals and the ECM controls the throttle control motor to make the throttle valve opening angle properly in response to driving condition.

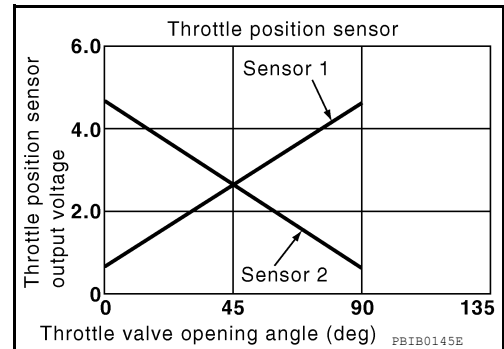

Ignition Coil With Power Transistor

INFOID:000000011277823

The ignition signal from the ECM is sent to and amplified by the power transistor. The power transistor turns ON and OFF the ignition coil primary circuit. This ON/OFF operation induces the proper high voltage in the coil secondary circuit.

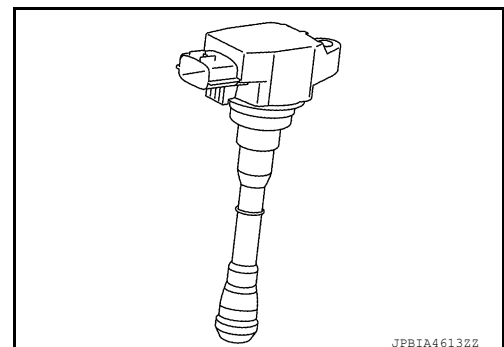

# COMPONENT PARTS

< SYSTEM DESCRIPTION >

[QR25DE]

## Fuel Injector

INFOID:000000011277824

The fuel injector is a small, precise solenoid valve. When the ECM supplies a ground to the fuel injector circuit, the coil in the fuel injector is energized. The energized coil pulls the ball valve back and allows fuel to flow through the fuel injector into the intake manifold. The amount of fuel injected depends upon the injection pulse duration. Pulse duration is the length of time the fuel injector remains open. The ECM controls the injection pulse duration based on engine fuel needs.

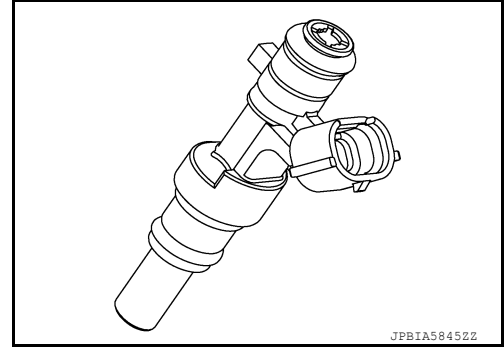

## Fuel Level Sensor Unit and Fuel Pump

INFOID:000000011277825

### FUEL PUMP

The ECM activates the fuel pump for 1 second after the ignition switch is turned ON to improve engine start ability. If the ECM receives a engine speed signal from the camshaft position sensor (PHASE), it knows that the engine is rotating, and causes the pump to operate. If the engine speed signal is not received when the ignition switch is ON, the engine stalls. The ECM stops pump operation and prevents battery discharging, thereby improving safety. The ECM does not directly drive the fuel pump. It sends the control signal to the fuel pump control module, which in turn controls the fuel pump.

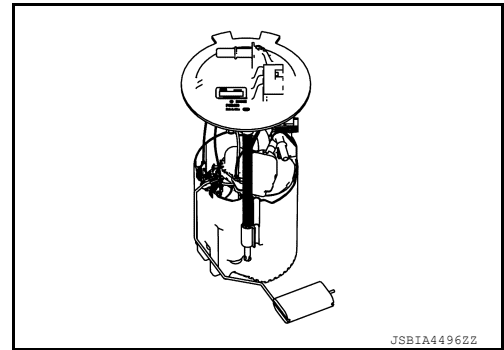

Condition	Fuel pump operation
Ignition switch is turned to ON.	Operates for 1 second.
Engine running and cranking	Operates.
When engine is stopped	Stops in 1.5 seconds.
Except as shown above	Stops.

### FUEL LEVEL SENSOR

The fuel level sensor is mounted in the fuel level sensor unit. The sensor detects a fuel level in the fuel tank and transmits a signal to the combination meter. The combination meter sends the fuel level sensor signal to the ECM via the CAN communication line. It consists of two parts, one is mechanical float and the other is variable resistor. Fuel level sensor output voltage changes depending on the movement of the fuel mechanical float.

## Fuel Tank Temperature Sensor

INFOID:000000011277826

The fuel tank temperature sensor is used to detect the fuel temperature inside the fuel tank. The sensor modifies a voltage signal from the ECM. The modified signal returns to the ECM as the fuel temperature input. The sensor uses a thermistor which is sensitive to the change in temperature. The electrical resistance of the thermistor decreases as temperature increases.

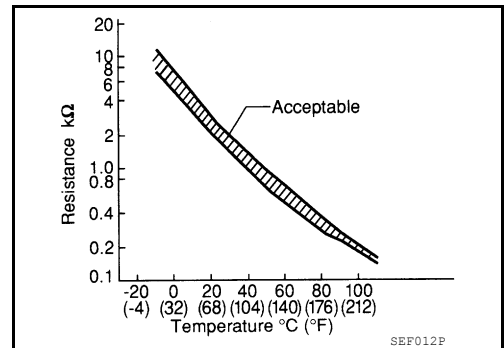

<Reference data>

Fluid temperature [°C (°F)]	Voltage* (V)	Resistance (kΩ)
20 (68)	3.5	2.3 - 2.7
50 (122)	2.2	0.79 - 0.90

\*: These data are reference values and are measured between ECM terminals.

## Mass Air Flow Sensor (With Intake Air Temperature Sensor)

INFOID:0000000011277827

### MASS AIR FLOW SENSOR

The mass air flow sensor ① is placed in the stream of intake air. It measures the intake flow rate by measuring a part of the entire intake flow. The MAF sensor controls the temperature of the heater in sensing element to a certain amount. The temperature distribution around the heater changes according to the increase in intake air volume. The change is detected by a thermistor and the air volume data is sent to ECM by the MAF sensor.

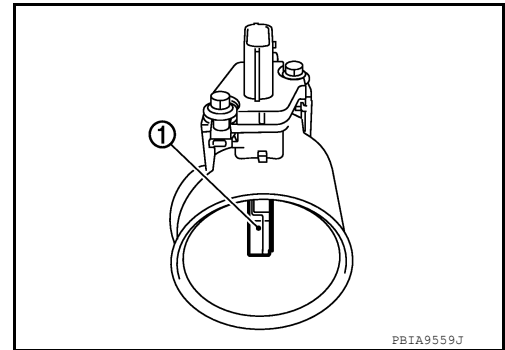

### INTAKE AIR TEMPERATURE SENSOR

The intake air temperature sensor is built-into mass air flow sensor. The sensor detects intake air temperature and transmits a signal to the ECM.

The temperature sensing unit uses a thermistor which is sensitive to the change in temperature.

#### <Reference data>

Intake air temperature [°C (°F)]	Voltage* (V)
25 (77)	1.9 - 2.1
80 (176)	3.2 - 3.4

\*: These data are reference values on the diagnosis tool.

## Engine Coolant Temperature Sensor

INFOID:0000000011277828

The engine coolant temperature sensor is used to detect the engine coolant temperature. The sensor modifies a voltage signal from the ECM. The modified signal returns to the ECM as the engine coolant temperature input. The sensor uses a thermistor which is sensitive to the change in temperature. The electrical resistance of the thermistor decreases as temperature increases.

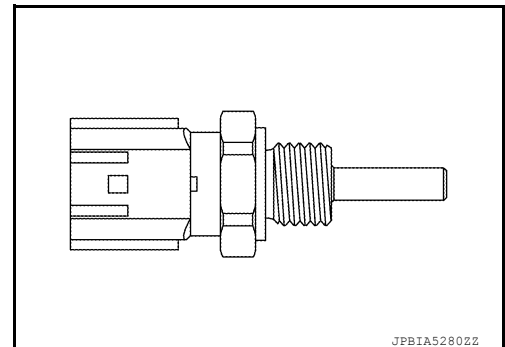

A  
EC  
C  
D  
E  
F  
G  
H  
I  
J  
K  
L  
M  
N  
O  
P

# COMPONENT PARTS

[QR25DE]

## < SYSTEM DESCRIPTION >

### <Reference data>

Engine coolant temperature [°C (°F)]	Voltage* (V)	Resistance (kΩ)
-10 (14)	4.4	7.0 - 11.4
20 (68)	3.5	2.37 - 2.63
50 (122)	2.2	0.68 - 1.00
90 (194)	1.0	0.236 - 0.260

\*: These data are reference values and are measured between ECM terminals.

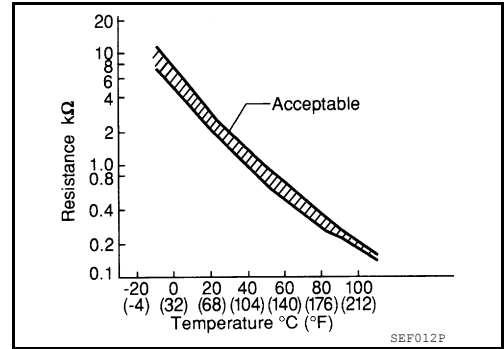

## Crankshaft Position Sensor (POS)

INFOID:000000011277829

The crankshaft position sensor (POS) is located on the oil pan facing the gear teeth (cogs) of the signal plate. It detects the fluctuation of the engine revolution.

The sensor consists of a permanent magnet and Hall IC.

When the engine is running, the high and low parts of the teeth cause the gap with the sensor to change.

The changing gap causes the magnetic field near the sensor to change.

Due to the changing magnetic field, the voltage from the sensor changes.

The ECM receives the voltage signal and detects the fluctuation of the engine revolution.

ECM receives the signals as shown in the figure.

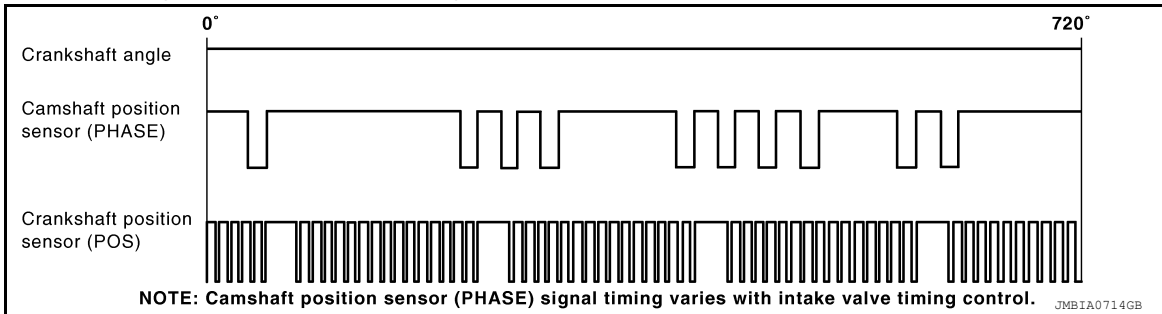
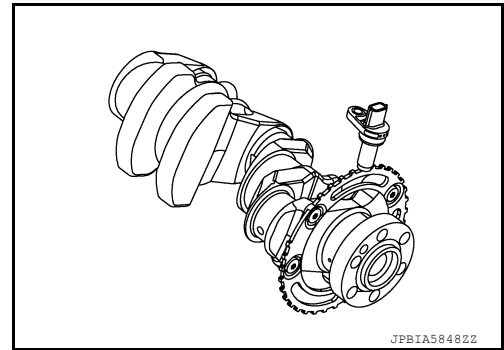

## Camshaft Position Sensor (PHASE)

INFOID:000000011277830

The camshaft position sensor (PHASE) senses the retraction of intake camshaft to identify a particular cylinder. The camshaft position sensor (PHASE) senses the piston position.

When the crankshaft position sensor (POS) system becomes inoperative, the camshaft position sensor (PHASE) provides various controls of engine parts instead, utilizing timing of cylinder identification signals.

The sensor consists of a permanent magnet and Hall IC.

When engine is running, the high and low parts of the teeth cause the gap with the sensor to change.

The changing gap causes the magnetic field near the sensor to change.

Due to the changing magnetic field, the voltage from the sensor changes.

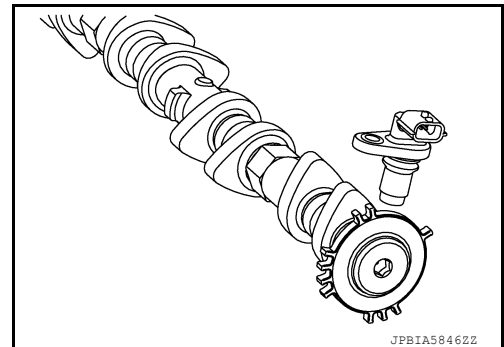

ECM receives the signals as shown in the figure.

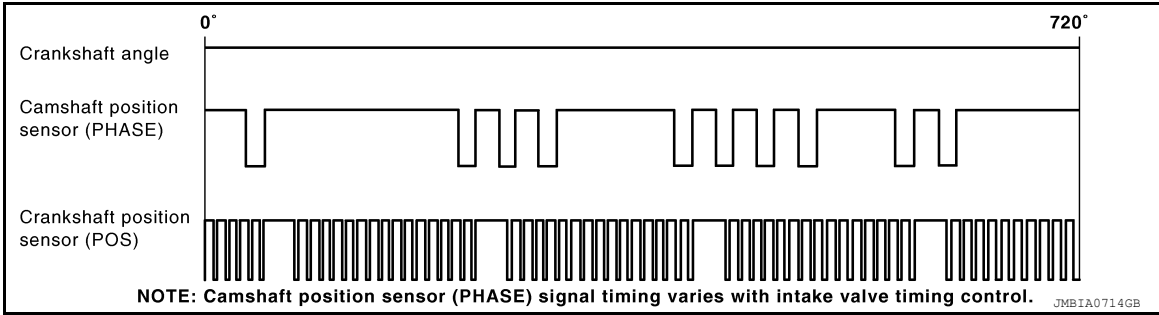

## Intake Valve Timing Control Solenoid Valve

INFOID:000000011277831

Intake valve timing control solenoid valve is activated by ON/OFF pulse duty (ratio) signals from the ECM.

The intake valve timing control solenoid valve changes the oil amount and direction of flow through intake valve timing control unit or stops oil flow.

The longer pulse width advances valve angle.

The shorter pulse width retards valve angle.

When ON and OFF pulse widths become equal, the solenoid valve stops oil pressure flow to fix the intake valve angle at the control position.

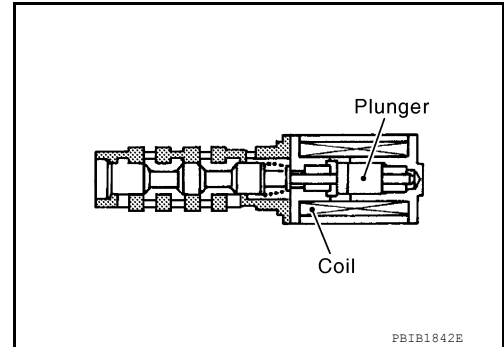

## Intake Valve Timing Intermediate Lock Control Solenoid Valve

INFOID:000000011277832

Intake valve timing intermediate lock control solenoid valve is activated by ON/OFF signals from the ECM.

The intake valve timing intermediate lock control solenoid valve opens/closes the path of oil pressure acting on the lock key in the camshaft sprocket (INT).

- When the solenoid valve becomes ON, oil pressure to the lock key is trained to perform intermediate lock.
- When the solenoid valve becomes OFF, oil pressure is acted on the lock key to release the intermediate lock.

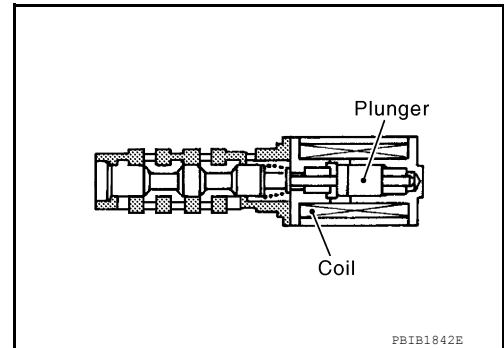

## Exhaust Valve Timing Control Position Sensor

INFOID:000000011277833

Exhaust valve timing control position sensor detects the protrusion of the signal plate installed to the exhaust camshaft front end.

This sensor signal is used for sensing a position of the exhaust camshaft.

The sensor consists of a permanent magnet and Hall IC.

When engine is running, the high and low parts of the teeth cause the gap with the sensor to change.

The changing gap causes the magnetic field near the sensor to change.

Due to the changing magnetic field, the voltage from the sensor changes.

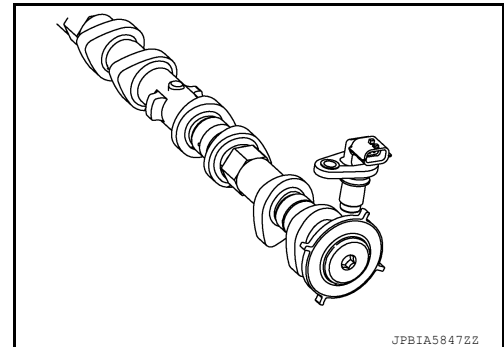

A  
EC  
C  
D  
E  
F  
G  
H  
I  
J  
K  
L  
M  
N  
O  
P

## Exhaust Valve Timing Control Solenoid Valve

INFOID:000000011277834

Exhaust valve timing control solenoid valve is activated by ON/OFF pulse duty (ratio) signals from the ECM.

The exhaust valve timing control solenoid valve changes the oil amount and direction of flow through exhaust valve timing control unit or stops oil flow.

The longer pulse width retards valve angle.

The shorter pulse width advances valve angle.

When ON and OFF pulse widths become equal, the solenoid valve stops oil pressure flow to fix the exhaust valve angle at the control position.

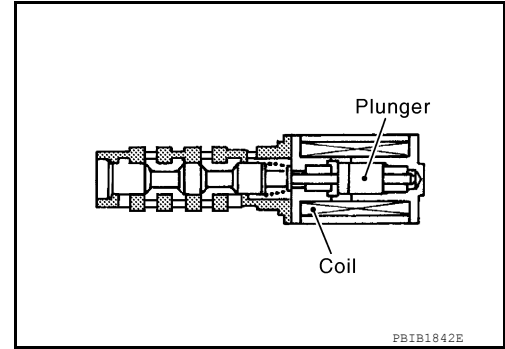

## Intake Manifold Runner Control Valve

INFOID:000000011277835

Intake manifold runner control valve① is integrated to intake manifold.

Intake manifold runner control valve is mounted each port of the intake manifold and opened/closed by the intake manifold runner control valve motor.

ECM controls the intake manifold runner control valve motor, according to signals of engine speed, water temperature, etc. and stabilizes combustion by generating a strong tumble flow.

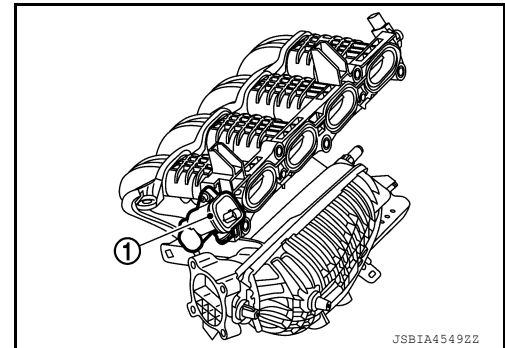

### INTAKE MANIFOLD RUNNER CONTROL VALVE MOTOR

Intake manifold runner control valve motor is connected to the rear end of the valve shaft.

The motor opens or closes the valve by the output signal of the ECM.

### INTAKE MANIFOLD RUNNER CONTROL VALVE POSITION SENSOR

Intake manifold runner control valve position sensor is connected to the front end of the valve shaft.

The sensor consists of variable resistor. It senses the valve shaft movement and feeds the voltage signals to the ECM.

## Air Fuel Ratio (A/F) Sensor 1

INFOID:000000011277836

The sensor element of the A/F sensor 1 is composed an electrode layer, which transports ions. It has a heater in the element.

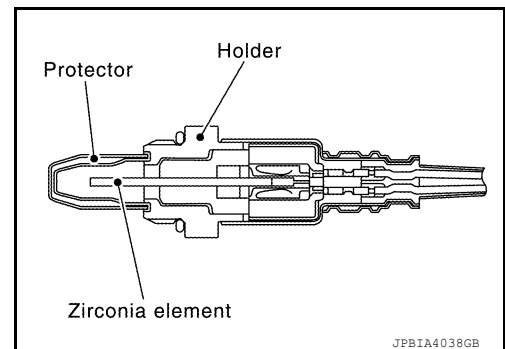

The sensor is capable of precise measurement  $\lambda = 1$ , but also in the lean and rich range. Together with its control electronics, the sensor outputs a clear, continuous signal throughout a wide  $\lambda$  range.

The exhaust gas components diffuse through the diffusion layer at the sensor cell. An electrode layer is applied voltage, and this current relative oxygen density in lean. Also this current relative hydrocarbon density in rich.



# COMPONENT PARTS

## < SYSTEM DESCRIPTION >

[QR25DE]

Therefore, the A/F sensor 1 is able to indicate air fuel ratio by this electrode layer of current. In addition, a heater is integrated in the sensor to ensure the required operating temperature of approximately 760°C (1,400°F).



### A/F SENSOR 1 HEATER

A/F sensor 1 heater is integrated in the sensor.

The ECM performs ON/OFF duty control of the A/F sensor 1 heater corresponding to the engine operating condition to keep the temperature of A/F sensor 1 element within the specified range.

### Heated Oxygen Sensor 2

INFOID:000000011277837

The heated oxygen sensor 2, after three way catalyst (manifold), monitors the oxygen level in the exhaust gas.

Even if switching characteristics of the air fuel ratio (A/F) sensor 1 are shifted, the air fuel ratio is controlled to stoichiometric, by the signal from the heated oxygen sensor 2.

This sensor is made of ceramic zirconia. The zirconia generates voltage from approximately 1 V in richer conditions to 0 V in leaner conditions.

Under normal conditions the heated oxygen sensor 2 is not used for engine control operation.

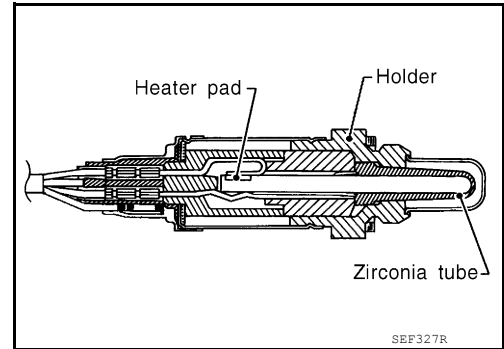

### HEATED OXYGEN SENSOR 2 HEATER

Heated oxygen sensor 2 heater is integrated in the sensor.

The ECM performs ON/OFF control of the heated oxygen sensor 2 heater corresponding to the engine speed, amount of intake air and engine coolant temperature.

Engine speed	Heated oxygen sensor 2 heater
Above 3,600 rpm	OFF
Below 3,600 rpm after the following conditions are met. <ul style="list-style-type: none"> <li>• Engine: After warming up</li> <li>• Keeping the engine speed between 3,500 and 4,000 rpm for 1 minute and at idle for 1 minute under no load</li> </ul>	ON

### Knock Sensor

INFOID:000000011277838

The knock sensor is attached to the cylinder block. It senses engine knocking using a piezoelectric element. A knocking vibration from the cylinder block is sensed as vibrational pressure. This pressure is converted into a voltage signal and sent to the ECM.

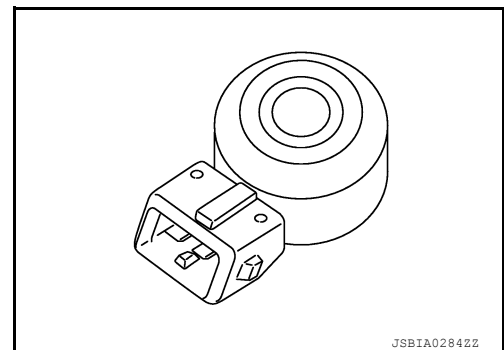

# COMPONENT PARTS

< SYSTEM DESCRIPTION >

[QR25DE]

## Engine Oil Pressure Sensor

INFOID:000000011277839

The engine oil pressure (EOP) sensor is detects engine oil pressure and transmits a voltage signal to the ECM.

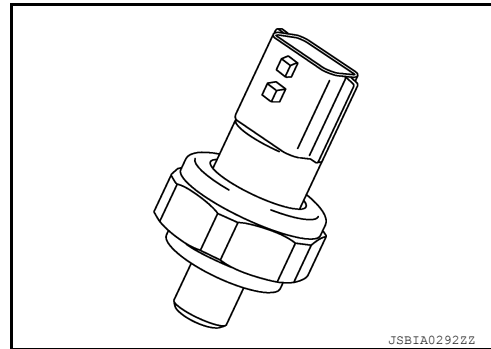

JSBIA02922Z

## Engine Oil Temperature Sensor

INFOID:000000011277840

The engine oil temperature sensor is used to detect the engine oil temperature. The sensor modifies a voltage signal from the ECM. The modified signal returns to the ECM as the engine oil temperature input. The sensor uses a thermistor which is sensitive to the change in temperature. The electrical resistance of the thermistor decreases as temperature increases.

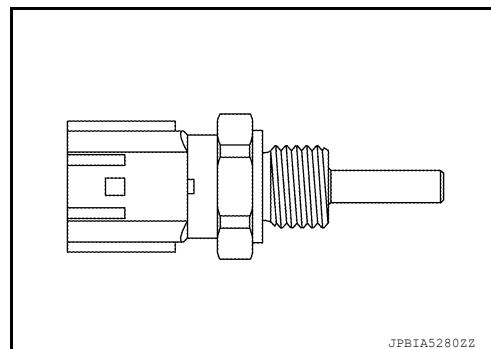

JPBIA52802Z

### <Reference data>

Engine oil temperature [°C (°F)]	Voltage* (V)	Resistance (kΩ)
-10 (14)	4.4	7.0 - 11.4
20 (68)	3.5	2.37 - 2.63
50 (122)	2.2	0.68 - 1.00
90 (194)	1.0	0.236 - 0.260
110 (230)	0.6	0.143 - 0.153

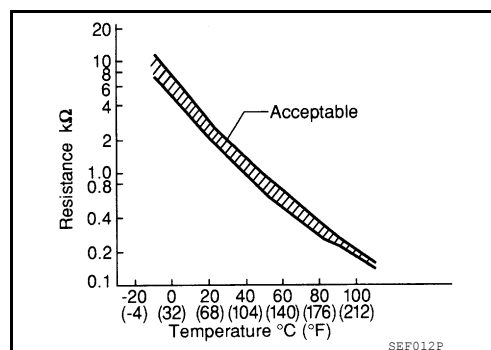

SEP012P

\*: These data are reference values and are measured between ECM terminals.

## Cooling Fan

INFOID:000000011277841

The ECM controls the cooling fan corresponding to the vehicle speed, engine coolant temperature, refrigerant pressure, and air conditioner ON signal. The control system has 4-step control [HIGH/MIDDLE/LOW/OFF]. Cooling fan operates at each speed when the current flows in the cooling fan motor. Refer to [EC-48, "COOLING FAN CONTROL : System Description"](#) for cooling fan operation.

# COMPONENT PARTS

< SYSTEM DESCRIPTION >

[QR25DE]

## EVAP Canister

INFOID:000000011277842

EVAP canister stores the generated fuel vapors in the sealed fuel tank to activated charcoals of EVAP canister when the engine is not operating or when refueling to the fuel tank.

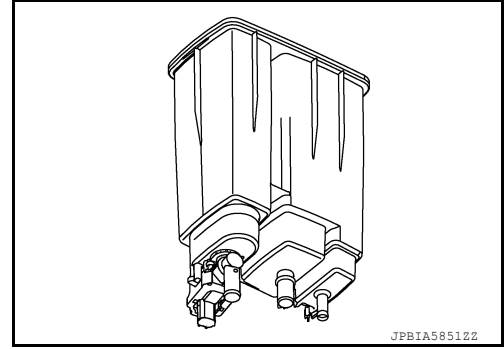

## EVAP Canister Purge Volume Control Solenoid Valve

INFOID:000000011277843

The EVAP canister purge volume control solenoid valve uses a ON/OFF duty to control the flow rate of fuel vapor from the EVAP canister. The EVAP canister purge volume control solenoid valve is moved by ON/OFF pulses from the ECM. The longer the ON pulse, the greater the amount of fuel vapor that will flow through the valve.

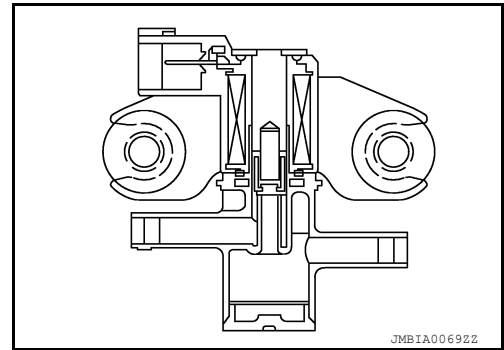

## EVAP Canister Vent Control Valve

INFOID:000000011277844

The EVAP canister vent control valve is located on the EVAP canister and is used to seal the canister vent.

This solenoid valve responds to signals from the ECM. When the ECM sends an ON signal, the coil in the solenoid valve is energized. A plunger will then move to seal the canister vent. The ability to seal the vent is necessary for the on board diagnosis of other evaporative emission control system components.

This solenoid valve is used only for diagnosis, and usually remains opened.

When the vent is closed, under normal purge conditions, the evaporative emission control system is depressurized and allows "EVAP Control System" diagnosis.

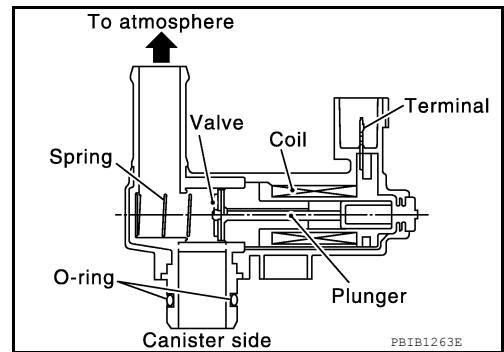

## EVAP Control System Pressure Sensor

INFOID:000000011277845

The EVAP control system pressure sensor detects pressure in the purge line. The sensor output voltage to the ECM increases as pressure increases.

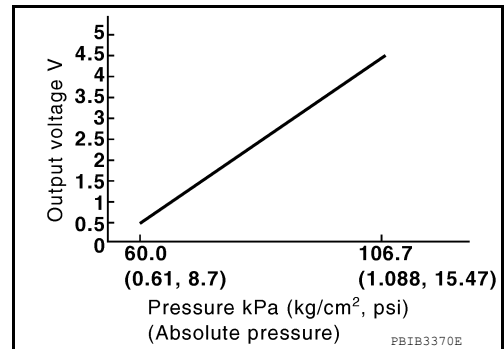

# COMPONENT PARTS

< SYSTEM DESCRIPTION >

[QR25DE]

## Refrigerant Pressure Sensor

INFOID:000000011277846

The refrigerant pressure sensor is installed at the condenser of the air conditioner system. The sensor uses an electrostatic volume pressure transducer to convert refrigerant pressure to voltage. The voltage signal is sent to ECM, and ECM controls cooling fan system.

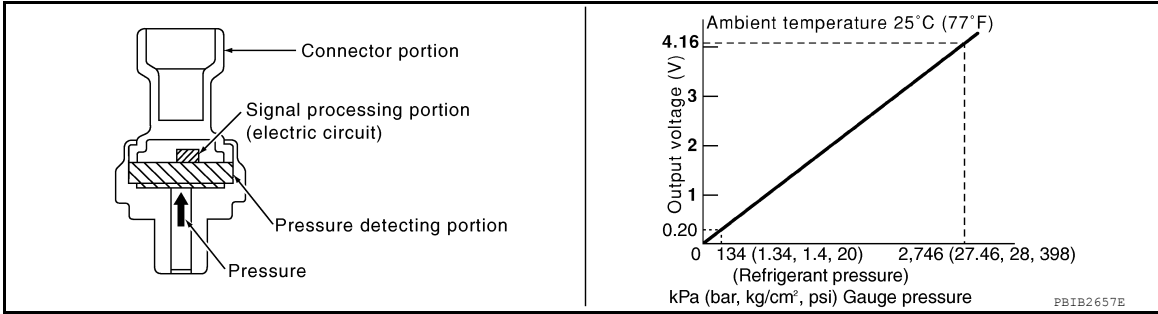

## Stop Lamp Switch & Brake Pedal Position Switch

INFOID:000000011277847

Stop lamp switch and brake pedal position switch are installed to brake pedal bracket. ECM detects the state of the brake pedal by those two types of input (ON/OFF signal).

Brake pedal	Brake pedal position switch	Stop lamp switch
Released	ON	OFF
Depressed	OFF	ON

## ASCD Steering Switch

INFOID:000000011277848

ASCD steering switch has variant values of electrical resistance for each button. ECM reads voltage variation of switch, and determines which button is operated.

## Information Display

INFOID:000000011277849

The operation mode of the ASCD is indicated on the information display in the combination meter. ECM transmits the status signal to the combination meter via CAN communication according to ASCD operation.

STRUCTURE AND OPERATION

Positive Crankcase Ventilation

INFOID:000000011277850

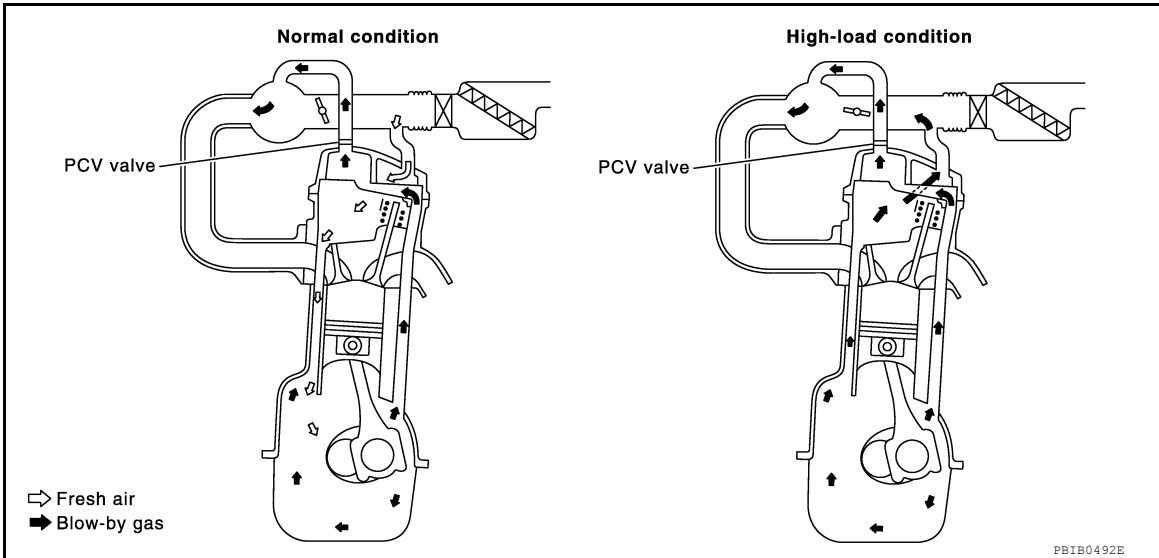

This system returns blow-by gas to the intake manifold.

The positive crankcase ventilation (PCV) valve is provided to conduct crankcase blow-by gas to the intake manifold.

During partial throttle operation of the engine, the intake manifold sucks the blow-by gas through the PCV valve.

Normally, the capacity of the valve is sufficient to handle any blow-by and a small amount of ventilating air.

The ventilating air is then drawn from the air inlet tubes into the crankcase. In this process the air passes through the hose connecting air inlet tubes to rocker cover.

Under full-throttle condition, the manifold vacuum is insufficient to draw the blow-by flow through the valve. The flow goes through the hose connection in the reverse direction.

On vehicles with an excessively high blow-by, the valve does not meet the requirement. This is because some of the flow will go through the hose connection to the air inlet tubes under all conditions.

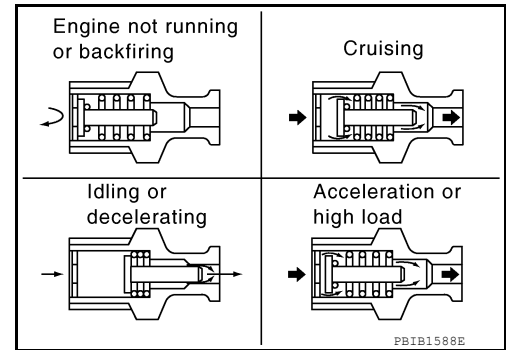

# STRUCTURE AND OPERATION

< SYSTEM DESCRIPTION >

[QR25DE]

## On Board Refueling Vapor Recovery (ORVR)

INFOID:000000011277851

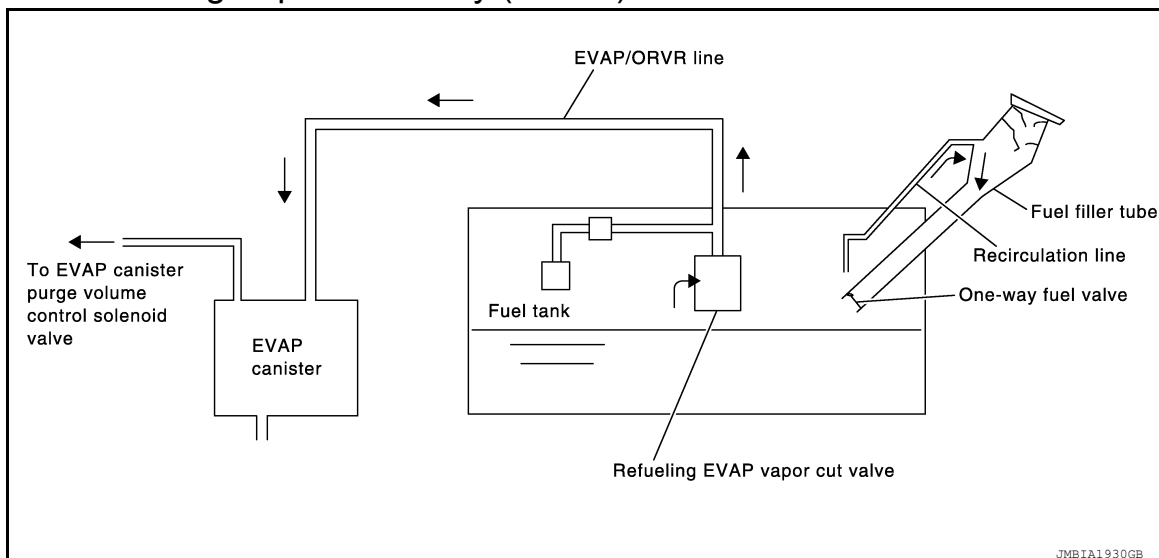

From the beginning of refueling, the air and vapor inside the fuel tank go through refueling EVAP vapor cut valve and EVAP/ORVR line to the EVAP canister. The vapor is absorbed by the EVAP canister and the air is released to the atmosphere.

When the refueling has reached the full level of the fuel tank, the refueling EVAP vapor cut valve is closed and refueling is stopped because of auto shut-off. The vapor which was absorbed by the EVAP canister is purged during driving.

### **WARNING:**

When conducting inspections below, be sure to observe the following:

- Put a “CAUTION: FLAMMABLE” sign in workshop.
- Do not smoke while servicing fuel system. Keep open flames and sparks away from work area.
- Be sure to furnish the workshop with a CO<sub>2</sub> fire extinguisher.

### **CAUTION:**

- Before removing fuel line parts, carry out the following procedures:
  - Put drained fuel in an explosion-proof container and put lid on securely.
  - Release fuel pressure from fuel line. Refer to [EC-147, "Work Procedure"](#).
  - Disconnect battery ground cable.
- Always replace O-ring when the fuel gauge retainer is removed.
- Do not kink or twist hose and tube when they are installed.
- Do not tighten hose and clamps excessively to avoid damaging hoses.
- After installation, run engine and check for fuel leaks at connection.
- Do not attempt to top off the fuel tank after the fuel pump nozzle shuts off automatically. Continued refueling may cause fuel overflow, resulting in fuel spray and possibly a fire.

SYSTEM  
ENGINE CONTROL SYSTEM

ENGINE CONTROL SYSTEM : System Description

INFOID:000000011277852

A

EC

SYSTEM DIAGRAM

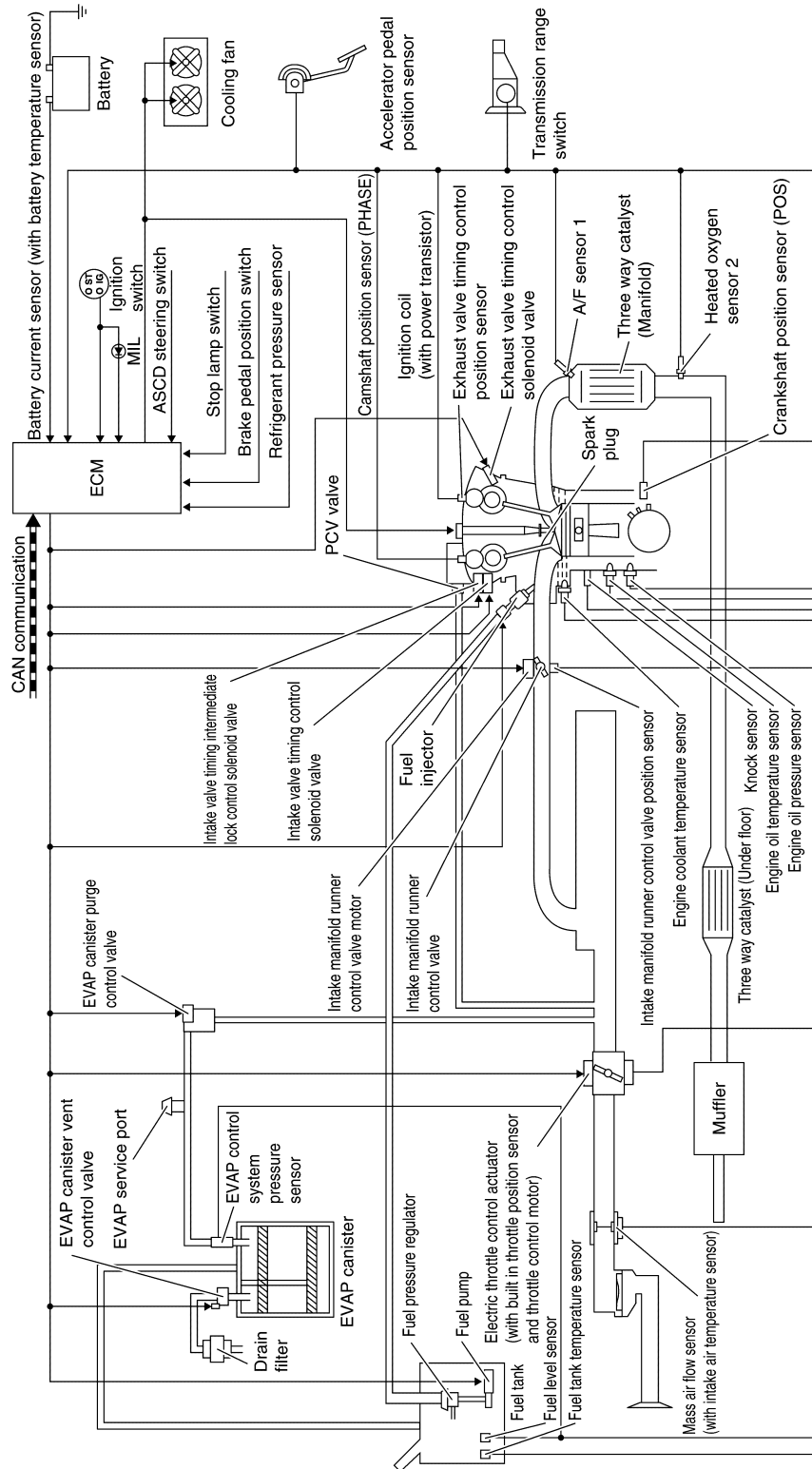

JSBIA4499GB

SYSTEM DESCRIPTION

C

D

E

F

G

H

I

J

K

L

M

N

O

P

# SYSTEM

< SYSTEM DESCRIPTION >

[QR25DE]

ECM controls the engine by various functions.

Function	Reference
Multiport fuel injection system	<a href="#">EC-37. "MULTIPORT FUEL INJECTION SYSTEM : System Description (with automatic air conditioner)"</a>
Electric ignition system	<a href="#">EC-41. "ELECTRIC IGNITION SYSTEM : System Description"</a>
Intake valve timing control	<a href="#">EC-42. "INTAKE VALVE TIMING CONTROL : System Description"</a>
Exhaust valve timing control	<a href="#">EC-45. "EXHAUST VALVE TIMING CONTROL : System Description"</a>
Intake manifold runner control	<a href="#">EC-46. "INTAKE MANIFOLD RUNNER CONTROL : System Description"</a>
Engine protection control	<a href="#">EC-46. "ENGINE PROTECTION CONTROL AT LOW ENGINE OIL PRESSURE : System Description"</a>
Fuel filler cap warning system	<a href="#">EC-50. "FUEL FILLER CAP WARNING SYSTEM : System Description"</a>
Air conditioning cut control	<a href="#">EC-47. "AIR CONDITIONING CUT CONTROL : System Description"</a>
Power generation voltage variable control	<a href="#">EC-47. "POWER GENERATION VOLTAGE VARIABLE CONTROL SYSTEM : System Description"</a>
Cooling fan control	<a href="#">EC-48. "COOLING FAN CONTROL : System Description"</a>
Evaporative emission system	<a href="#">EC-55. "EVAPORATIVE EMISSION SYSTEM : System Description"</a>
Automatic speed control device (ASCD)	<a href="#">EC-49. "AUTOMATIC SPEED CONTROL DEVICE (ASCD) : System Description"</a>
CAN communication	<a href="#">EC-55. "CAN COMMUNICATION : System Description"</a>
Sport mode	<a href="#">EC-56. "SPORT MODE CONTROL : System Description"</a>



# SYSTEM

< SYSTEM DESCRIPTION >

[QR25DE]

## ENGINE CONTROL SYSTEM : Circuit Diagram

INFOID:000000011518216

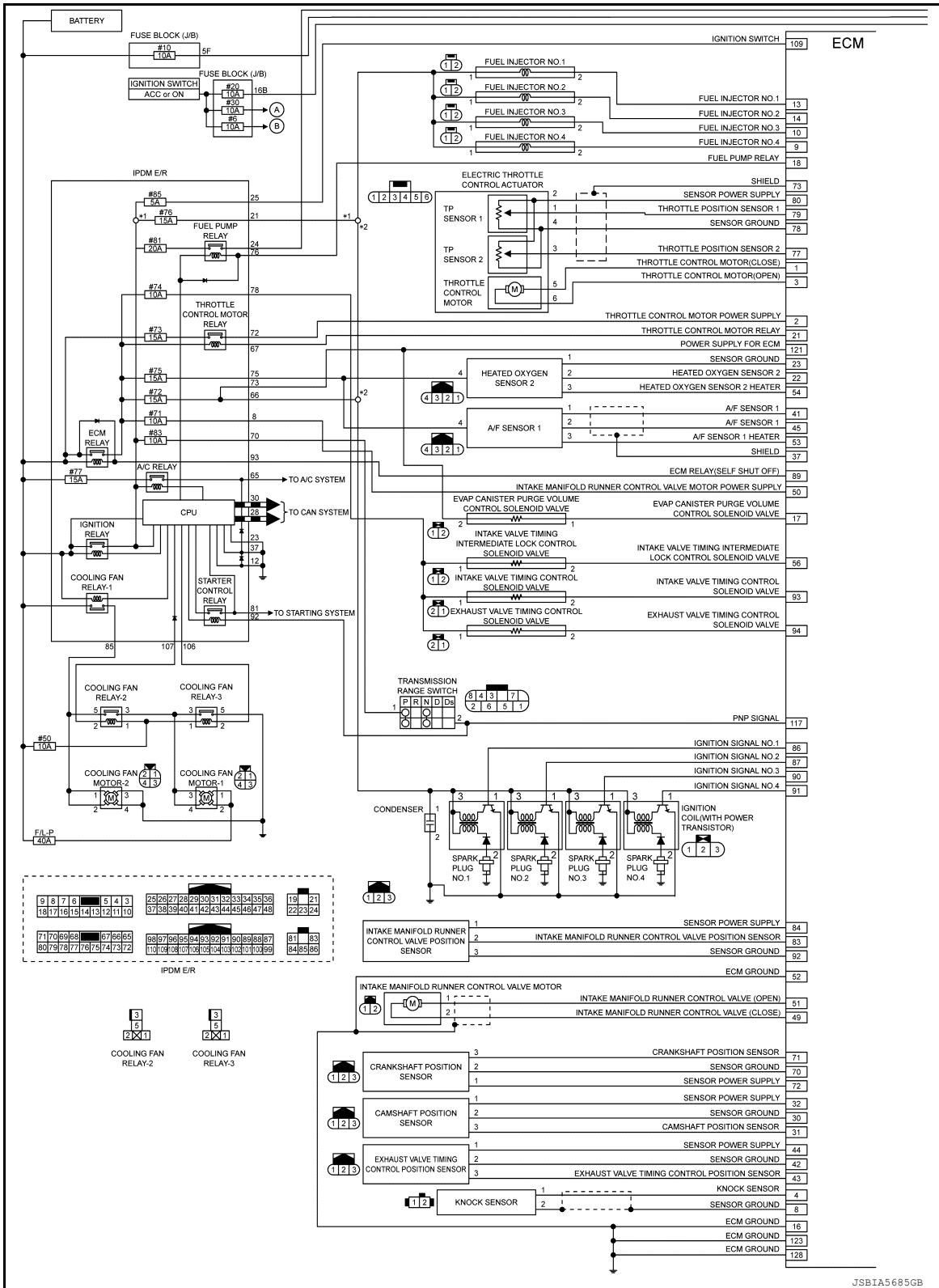

JSBIA5685GB

# SYSTEM

< SYSTEM DESCRIPTION >

[QR25DE]

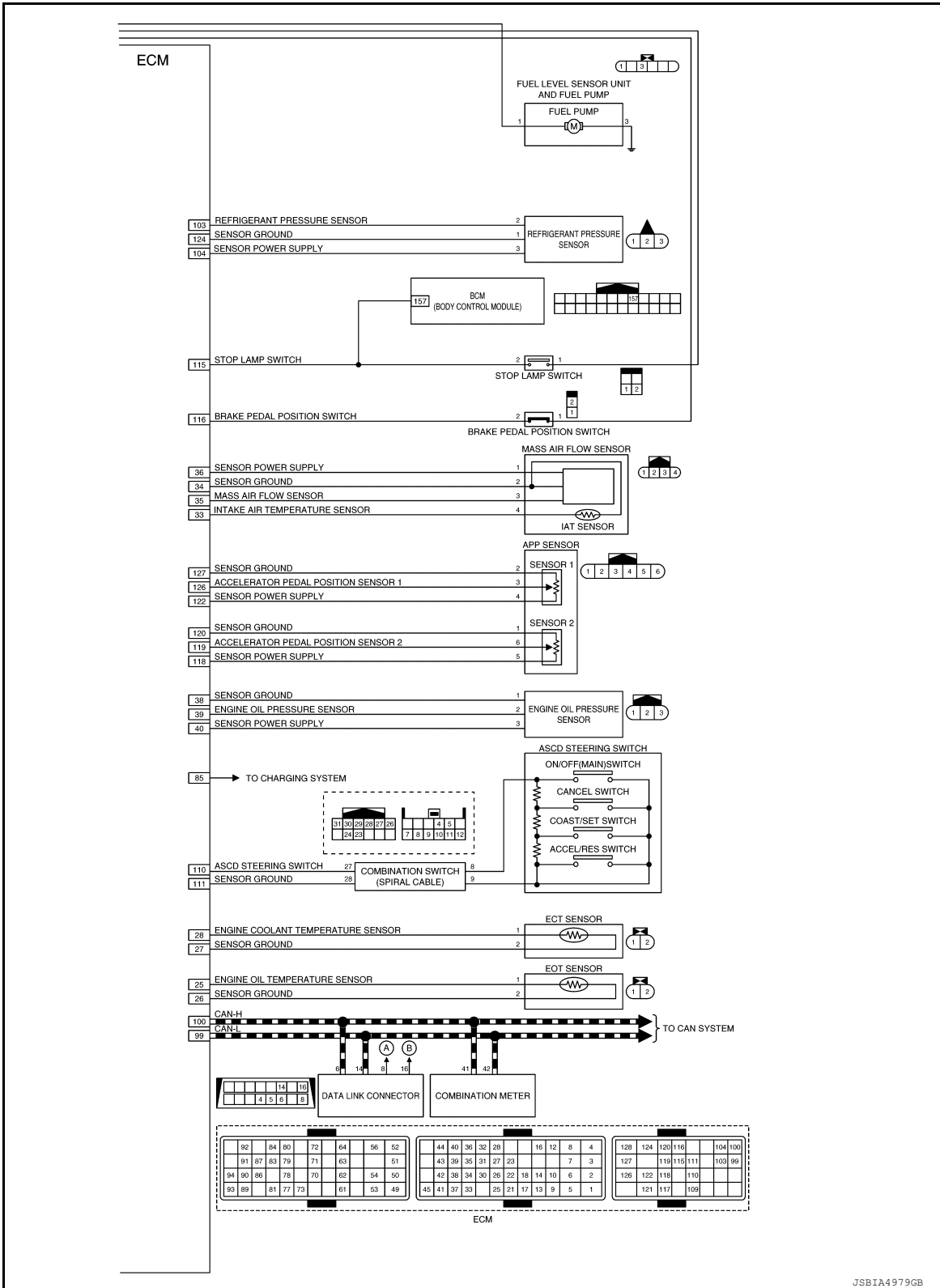

JSBIA4979GB

ENGINE CONTROL SYSTEM : Fail Safe

INFOID:000000011551458

NON DTC RELATED ITEM

# SYSTEM

< SYSTEM DESCRIPTION >

[QR25DE]

Detected items	Engine operating condition in fail-safe mode	Remarks	Reference page
Malfunction indicator lamp circuit	Engine speed will not rise more than 2,500 rpm due to the fuel cut	When there is an open circuit on MIL circuit, the ECM cannot warn the driver by lighting up MIL when there is malfunction on engine control system. Therefore, when electrical controlled throttle and part of ECM related diagnoses are continuously detected as NG for 5 trips, ECM warns the driver that engine control system malfunctions and MIL circuit is open by means of operating fail safe function. The fail safe function also operates when above diagnoses except MIL circuit are detected and demands the driver to repair the malfunction.	<a href="#">EC-479. "Component Function Check"</a>

## DTC RELATED ITEM

### Description

When a DTC is detected, ECM executes a mode (in the Fail-safe mode) applicable to the DTC. The fail-safe mode has the preset traveling control mode (accelerator angle variation and engine output limit) and device fix mode.

Fail safe mode	Vehicle behavior
Traveling control mode	Accelerator angle variation control ECM controls the accelerator pedal depression speed to make it slower than actual speed. This causes a drop in accelerating performance and encourages the driver to repair malfunction. <b>NOTE:</b> ECM does not control the accelerator pedal releasing speed.
	Engine output control ECM reduces the engine output, according to the rise in engine speed. This reduces the vehicle speed to encourage the driver to repair malfunction.
Device fix mode	<ul style="list-style-type: none"> <li>This mode fixes the IVT control solenoid valve and the EVT control solenoid valve in the reference position.</li> <li>The intake manifold runner control valve motor is turned OFF (intake manifold runner control valve opens).</li> </ul>

### Fail Safe Pattern

Pattern	Fail safe mode	
A	Traveling control mode	Accelerator angle variation control
B		Engine output control
C	Device fix mode	

### Fail Safe List

×:Applicable —: Not applicable

DTC No.	Detected items	Vehicle behavior				Others
		Pattern				
		A	B	C		
P0011	Intake valve timing control	—	—	×	×	ECM activates the IVT intermediate lock control solenoid valve to bring the cam sprocket into an intermediate lock condition.
P0014 P0078	Exhaust valve timing control	—	—	×	—	—
P0101 P0102 P0103	Mass air flow sensor circuit	×	×	×	—	—
P0122 P0123 P0222 P0223 P2135	Throttle position sensor	—	—	—	—	The ECM controls the electric throttle control actuator in regulating the throttle opening in order for the idle position to be within +10 degrees. The ECM regulates the opening speed of the throttle valve to be slower than the normal condition. So, the acceleration will be poor.

# SYSTEM

< SYSTEM DESCRIPTION >

[QR25DE]

DTC No.	Detected items	Vehicle behavior			
		Pattern			Others
		A	B	C	
P0171 P0172	Fuel injection system	×	—	—	—
P0197 P0198	Engine oil temperature sensor	—	—	—	Exhaust valve timing control does not function.
P0300 P0301 P0302 P0303 P0304	Misfire	×	—	—	—
P0500	Vehicle speed sensor	×	—	—	—
P050A	Cold start control	—	—	—	—
P0524	Engine oil pressure	—	—	—	<ul style="list-style-type: none"> <li>ECM illuminates oil pressure warning lamp on the combination meter.</li> <li>Engine speed will not rise more than 4,000rpm due to the fuel cut.</li> <li>Fail-safe is canceled when ignition switch OFF → ON.</li> </ul>
P052A P052B	Intake valve timing intermediate lock control	—	—	×	—
P0603	ECM	—	—	—	—
		—	×	—	ASCD operation may be deactivated.
P0604	ECM	×	—	×	ASCD operation may be deactivated.
P0605 P060B	ECM	—	—	—	—
		×	—	×	ASCD operation may be deactivated.
P0606	ECM	—	—	—	ASCD operation may be deactivated.
		×	—	×	ASCD operation may be deactivated.
P0607	ECM	—	—	—	—
		—	×	—	—
P060A	ECM	×	—	×	—
		×	×	×	ASCD operation may be deactivated.
P0643	ECM	×	—	×	—
P1078	Exhaust valve timing control position sensor circuit	×	—	×	—
P1568	Signal invalid	—	—	—	Active trace control does not function.
P1805	Brake switch	—	—	—	ECM controls the electric throttle control actuator by regulating the throttle opening to a small range. Therefore, acceleration will be poor.
		Vehicle condition		Driving condition	
		When engine is idling		Normal	
		When accelerating		Poor acceleration	
P2004	Intake manifold runner control valve	—	×	×	—
P2100 P2103	Throttle control motor relay	—	—	—	ECM stops the electric throttle control actuator control, throttle valve is maintained at a fixed opening (approx. 5 degrees) by the return spring.
P2101	Electric throttle control function	—	—	—	ECM stops the electric throttle control actuator control, throttle valve is maintained at a fixed opening (approx. 5 degrees) by the return spring.

# SYSTEM

< SYSTEM DESCRIPTION >

[QR25DE]

DTC No.	Detected items	Vehicle behavior			
		Pattern			Others
		A	B	C	
P2118	Throttle control motor	—	—	—	ECM stops the electric throttle control actuator control, throttle valve is maintained at a fixed opening (approx. 5 degrees) by the return spring.
P2119	Electric throttle control actuator	—	×	—	—
P2122 P2123 P2127 P2128 P2138	Accelerator pedal position sensor	—	—	—	The ECM controls the electric throttle control actuator in regulating the throttle opening in order for the idle position to be within +10 degrees. The ECM regulates the opening speed of the throttle valve to be slower than the normal condition. So, the acceleration will be poor.

## MULTIPOINT FUEL INJECTION SYSTEM

### MULTIPOINT FUEL INJECTION SYSTEM : System Description (with automatic air conditioner)

INFOID:000000011277854

### SYSTEM DIAGRAM

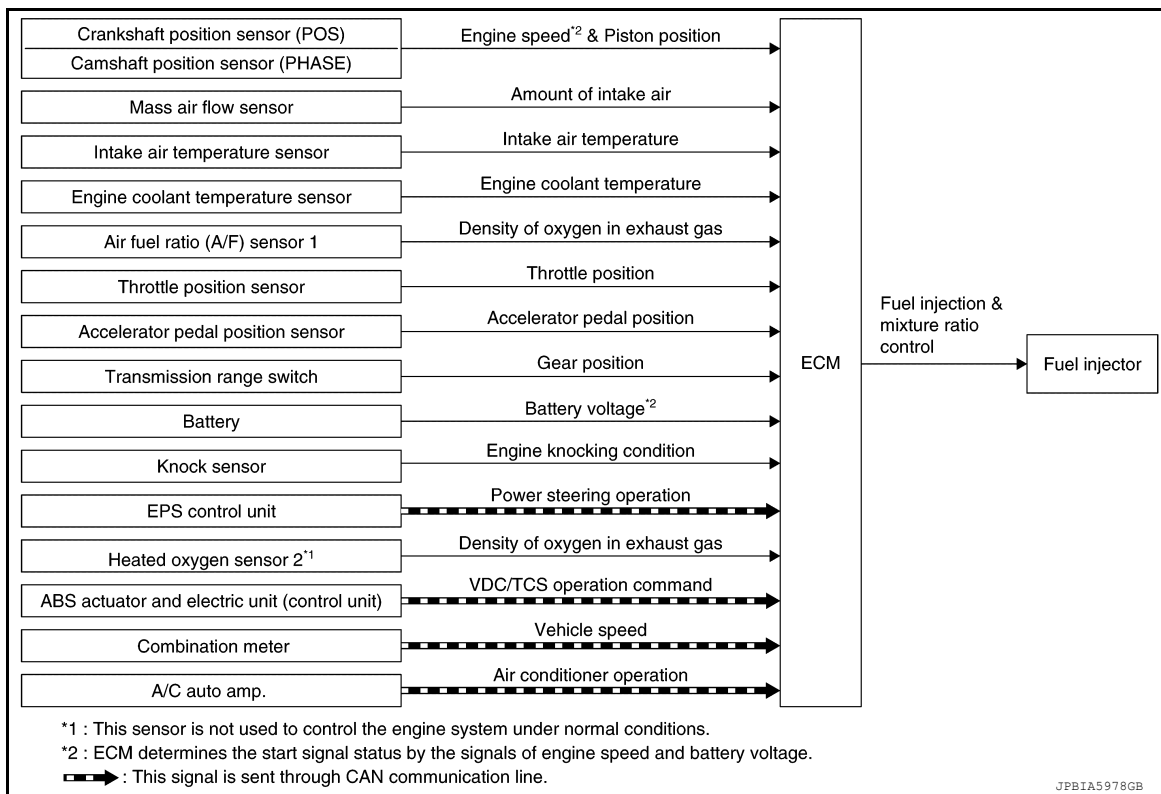

### SYSTEM DESCRIPTION

The amount of fuel injected from the fuel injector is determined by the ECM. The ECM controls the length of time the valve remains open (injection pulse duration). The amount of fuel injected is a program value in the ECM memory. The program value is preset by engine operating conditions. These conditions are determined by input signals (for engine speed and intake air) from the crankshaft position sensor (POS), camshaft position sensor (PHASE) and the mass air flow sensor.

### VARIOUS FUEL INJECTION INCREASE/DECREASE COMPENSATION

In addition, the amount of fuel injected is compensated to improve engine performance under various operating conditions as listed below.

<Fuel increase>

- During warm-up

## &lt; SYSTEM DESCRIPTION &gt;

- When starting the engine
- During acceleration
- Hot-engine operation
- When selector lever is changed from N to D
- High-load, high-speed operation

## &lt;Fuel decrease&gt;

- During deceleration
- During high engine speed operation

## MIXTURE RATIO FEEDBACK CONTROL (CLOSED LOOP CONTROL)

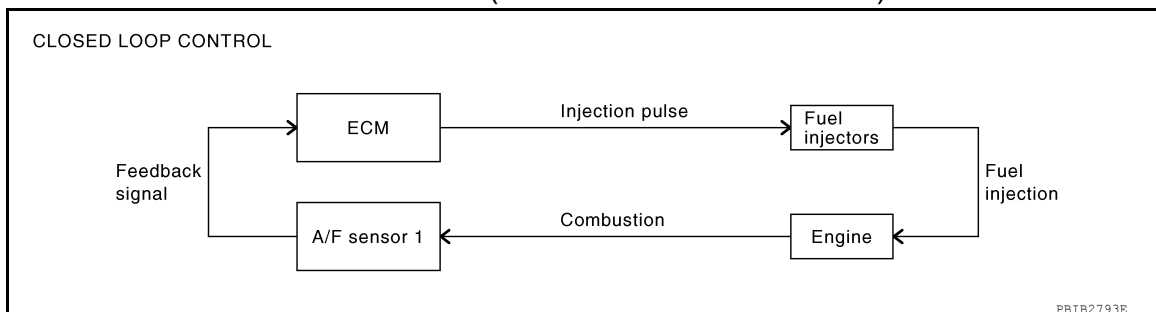

The mixture ratio feedback system provides the best air-fuel mixture ratio for driveability and emission control. The three way catalyst (manifold) can then better reduce CO, HC and NOx emissions. This system uses A/F sensor 1 in the exhaust manifold to monitor whether the engine operation is rich or lean. The ECM adjusts the injection pulse width according to the sensor voltage signal. For more information about A/F sensor 1, refer to [EC-24, "Air Fuel Ratio \(A/F\) Sensor 1"](#). This maintains the mixture ratio within the range of stoichiometric (ideal air-fuel mixture).

This stage is referred to as the closed loop control condition.

Heated oxygen sensor 2 is located downstream of the three way catalyst (manifold). Even if the switching characteristics of A/F sensor 1 shift, the air-fuel ratio is controlled to stoichiometric by the signal from heated oxygen sensor 2.

## • Open Loop Control

The open loop system condition refers to when the ECM detects any of the following conditions. Feedback control stops in order to maintain stabilized fuel combustion.

- Deceleration and acceleration
- High-load, high-speed operation
- Malfunction of A/F sensor 1 or its circuit
- Insufficient activation of A/F sensor 1 at low engine coolant temperature
- High engine coolant temperature
- During warm-up
- After shifting from N to D
- When starting the engine

## MIXTURE RATIO SELF-LEARNING CONTROL

The mixture ratio feedback control system monitors the mixture ratio signal transmitted from A/F sensor 1. This feedback signal is then sent to the ECM. The ECM controls the basic mixture ratio as close to the theoretical mixture ratio as possible. However, the basic mixture ratio is not necessarily controlled as originally designed. Both manufacturing differences (i.e., mass air flow sensor hot wire) and characteristic changes during operation (i.e., fuel injector clogging) directly affect mixture ratio.

Accordingly, the difference between the basic and theoretical mixture ratios is monitored in this system. This is then computed in terms of "injection pulse duration" to automatically compensate for the difference between the two ratios.

"Fuel trim" refers to the feedback compensation value compared against the basic injection duration. Fuel trim includes short term fuel trim and long term fuel trim.

"Short term fuel trim" is the short-term fuel compensation used to maintain the mixture ratio at its theoretical value. The signal from A/F sensor 1 indicates whether the mixture ratio is RICH or LEAN compared to the theoretical value. The signal then triggers a reduction in fuel volume if the mixture ratio is rich, and an increase in fuel volume if it is lean.

"Long term fuel trim" is overall fuel compensation carried out long-term to compensate for continual deviation of the short term fuel trim from the central value. Such deviation will occur due to individual engine differences, wear over time and changes in the usage environment.

## FUEL INJECTION TIMING

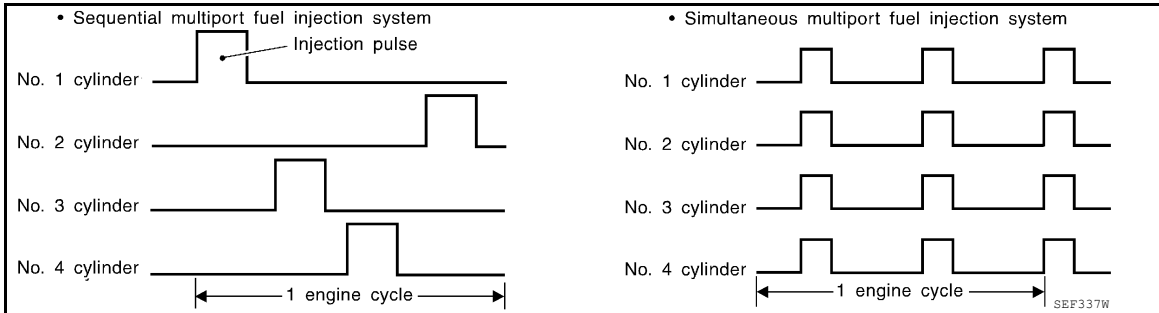

Two types of systems are used.

- Sequential Multiport Fuel Injection System

Fuel is injected into each cylinder during each engine cycle according to the firing order. This system is used when the engine is running.

- Simultaneous Multiport Fuel Injection System

Fuel is injected simultaneously into all four cylinders twice each engine cycle. In other words, pulse signals of the same width are simultaneously transmitted from the ECM.

The four injectors will then receive the signals two times for each engine cycle.

This system is used when the engine is being started and/or if the fail-safe system (CPU) is operating.

## FUEL SHUT-OFF

Fuel to each cylinder is cut off during deceleration, operation of the engine at excessively high speeds or operation of the vehicle at excessively high speeds.

## MULTIPOINT FUEL INJECTION SYSTEM : System Description (with manual air conditioner)

INFOID:0000000011277855

## SYSTEM DIAGRAM

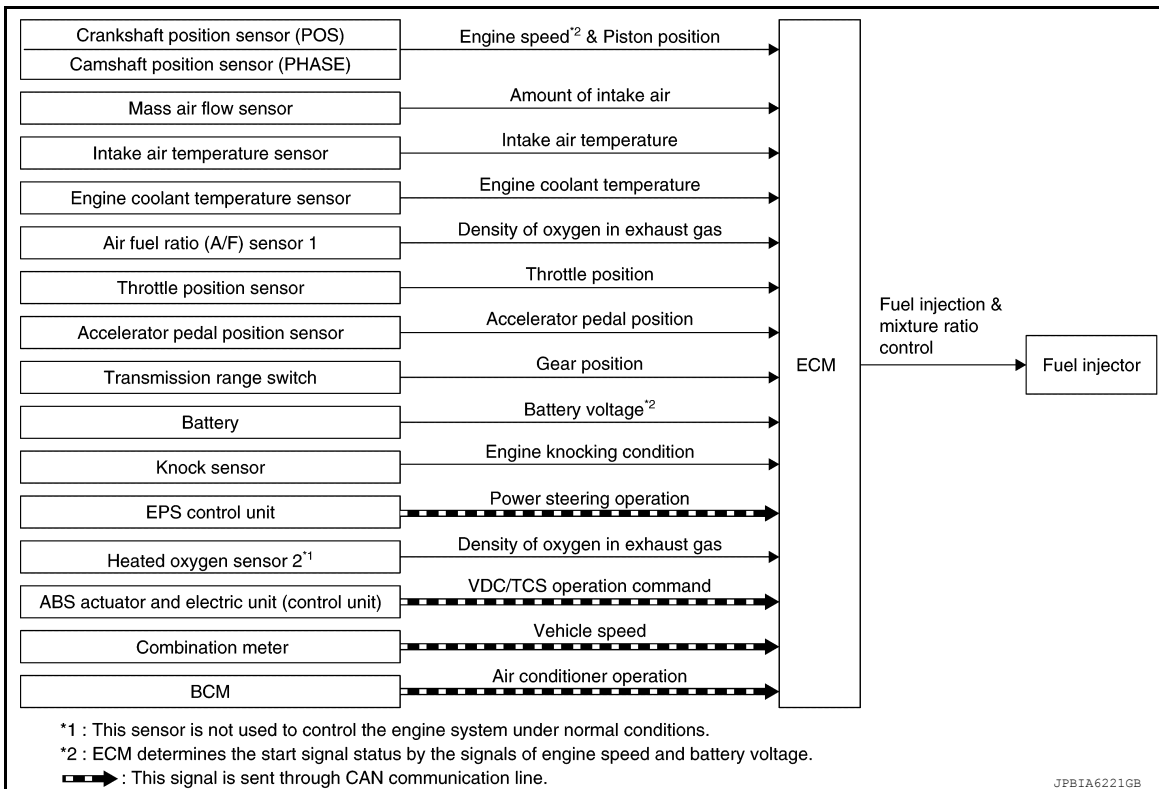

## SYSTEM DESCRIPTION

The amount of fuel injected from the fuel injector is determined by the ECM. The ECM controls the length of time the valve remains open (injection pulse duration). The amount of fuel injected is a program value in the ECM memory. The program value is preset by engine operating conditions. These conditions are determined

# SYSTEM

[QR25DE]

## < SYSTEM DESCRIPTION >

by input signals (for engine speed and intake air) from the crankshaft position sensor (POS), camshaft position sensor (PHASE) and the mass air flow sensor.

### VARIOUS FUEL INJECTION INCREASE/DECREASE COMPENSATION

In addition, the amount of fuel injected is compensated to improve engine performance under various operating conditions as listed below.

#### <Fuel increase>

- During warm-up
- When starting the engine
- During acceleration
- Hot-engine operation
- When selector lever is changed from N to D
- High-load, high-speed operation

#### <Fuel decrease>

- During deceleration
- During high engine speed operation

### MIXTURE RATIO FEEDBACK CONTROL (CLOSED LOOP CONTROL)

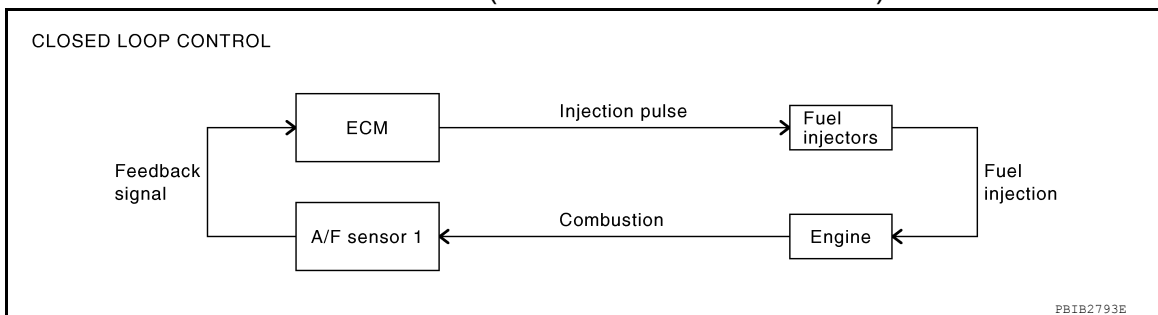

The mixture ratio feedback system provides the best air-fuel mixture ratio for driveability and emission control. The three way catalyst (manifold) can then better reduce CO, HC and NOx emissions. This system uses A/F sensor 1 in the exhaust manifold to monitor whether the engine operation is rich or lean. The ECM adjusts the injection pulse width according to the sensor voltage signal. For more information about A/F sensor 1, refer to [EC-24, "Air Fuel Ratio \(A/F\) Sensor 1"](#). This maintains the mixture ratio within the range of stoichiometric (ideal air-fuel mixture).

This stage is referred to as the closed loop control condition.

Heated oxygen sensor 2 is located downstream of the three way catalyst (manifold). Even if the switching characteristics of A/F sensor 1 shift, the air-fuel ratio is controlled to stoichiometric by the signal from heated oxygen sensor 2.

#### • Open Loop Control

The open loop system condition refers to when the ECM detects any of the following conditions. Feedback control stops in order to maintain stabilized fuel combustion.

- Deceleration and acceleration
- High-load, high-speed operation
- Malfunction of A/F sensor 1 or its circuit
- Insufficient activation of A/F sensor 1 at low engine coolant temperature
- High engine coolant temperature
- During warm-up
- After shifting from N to D
- When starting the engine

### MIXTURE RATIO SELF-LEARNING CONTROL

The mixture ratio feedback control system monitors the mixture ratio signal transmitted from A/F sensor 1. This feedback signal is then sent to the ECM. The ECM controls the basic mixture ratio as close to the theoretical mixture ratio as possible. However, the basic mixture ratio is not necessarily controlled as originally designed. Both manufacturing differences (i.e., mass air flow sensor hot wire) and characteristic changes during operation (i.e., fuel injector clogging) directly affect mixture ratio.

Accordingly, the difference between the basic and theoretical mixture ratios is monitored in this system. This is then computed in terms of "injection pulse duration" to automatically compensate for the difference between the two ratios.

"Fuel trim" refers to the feedback compensation value compared against the basic injection duration. Fuel trim includes short term fuel trim and long term fuel trim.



# SYSTEM

[QR25DE]

## < SYSTEM DESCRIPTION >

“Short term fuel trim” is the short-term fuel compensation used to maintain the mixture ratio at its theoretical value. The signal from A/F sensor 1 indicates whether the mixture ratio is RICH or LEAN compared to the theoretical value. The signal then triggers a reduction in fuel volume if the mixture ratio is rich, and an increase in fuel volume if it is lean.

“Long term fuel trim” is overall fuel compensation carried out long-term to compensate for continual deviation of the short term fuel trim from the central value. Such deviation will occur due to individual engine differences, wear over time and changes in the usage environment.

## FUEL INJECTION TIMING

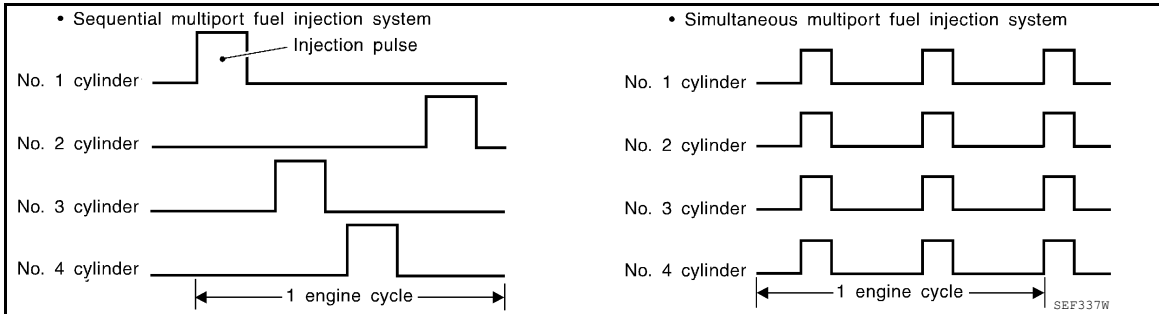

Two types of systems are used.

- Sequential Multiport Fuel Injection System

Fuel is injected into each cylinder during each engine cycle according to the firing order. This system is used when the engine is running.

- Simultaneous Multiport Fuel Injection System

Fuel is injected simultaneously into all four cylinders twice each engine cycle. In other words, pulse signals of the same width are simultaneously transmitted from the ECM.

The four injectors will then receive the signals two times for each engine cycle.

This system is used when the engine is being started and/or if the fail-safe system (CPU) is operating.

## FUEL SHUT-OFF

Fuel to each cylinder is cut off during deceleration, operation of the engine at excessively high speeds or operation of the vehicle at excessively high speeds.

## ELECTRIC IGNITION SYSTEM

### ELECTRIC IGNITION SYSTEM : System Description

INFOID:000000011277856

### SYSTEM DIAGRAM

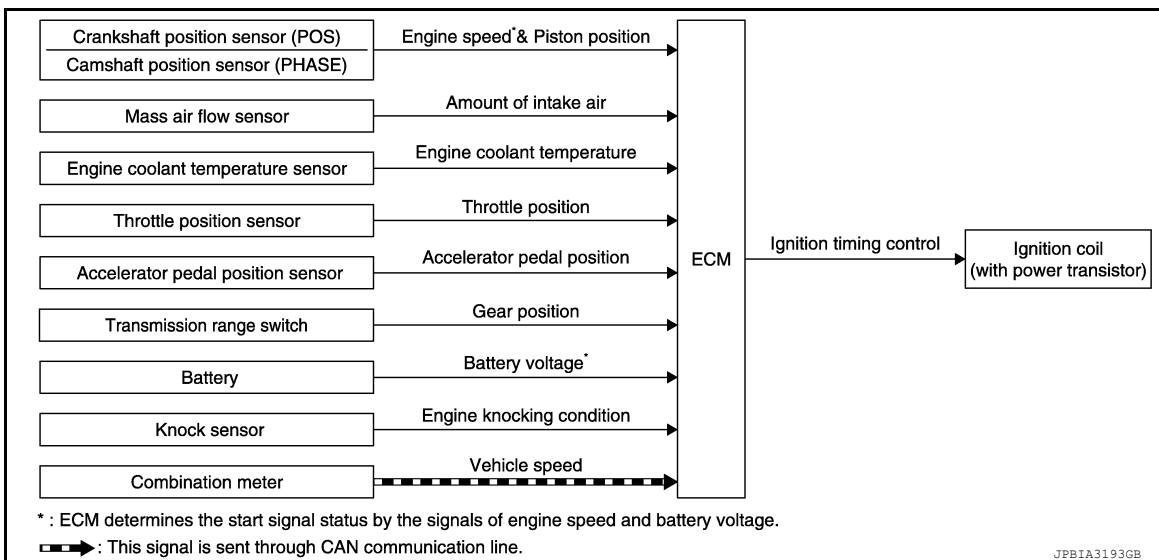

### SYSTEM DESCRIPTION

Firing order: 1 - 3 - 4 - 2

The ignition timing is controlled by the ECM to maintain the best air-fuel ratio for every running condition of the engine. The ignition timing data is stored in the ECM.

# SYSTEM

[QR25DE]

## < SYSTEM DESCRIPTION >

The ECM receives information such as the injection pulse width and camshaft position sensor (PHASE) signal. Computing this information, ignition signals are transmitted to the power transistor. During the following conditions, the ignition timing is revised by the ECM according to the other data stored in the ECM.

- At starting
- During warm-up
- At idle
- At low battery voltage
- During acceleration

The knock sensor retard system is designed only for emergencies. The basic ignition timing is programmed within the anti-knocking zone, if recommended fuel is used under dry conditions. The retard system does not operate under normal driving conditions. If engine knocking occurs, the knock sensor monitors the condition. The signal is transmitted to the ECM. The ECM retards the ignition timing to eliminate the knocking condition.

## INTAKE VALVE TIMING CONTROL

### INTAKE VALVE TIMING CONTROL : System Description

INFOID:000000011277857

### INTAKE VALVE TIMING CONTROL

#### System Diagram

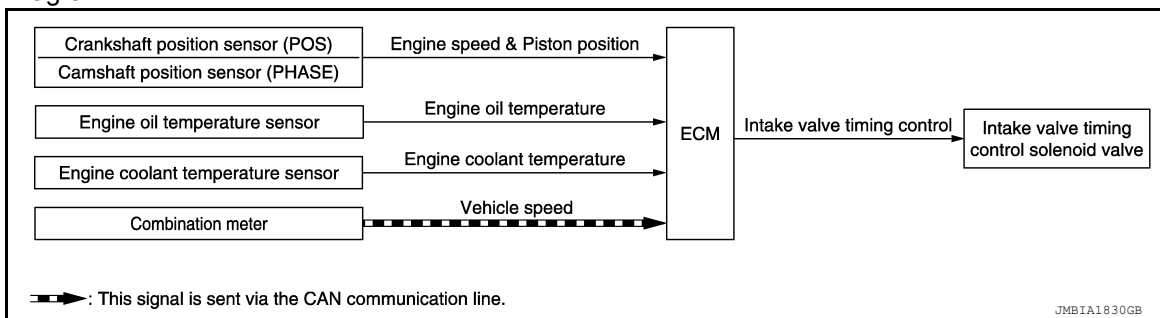

#### System Description

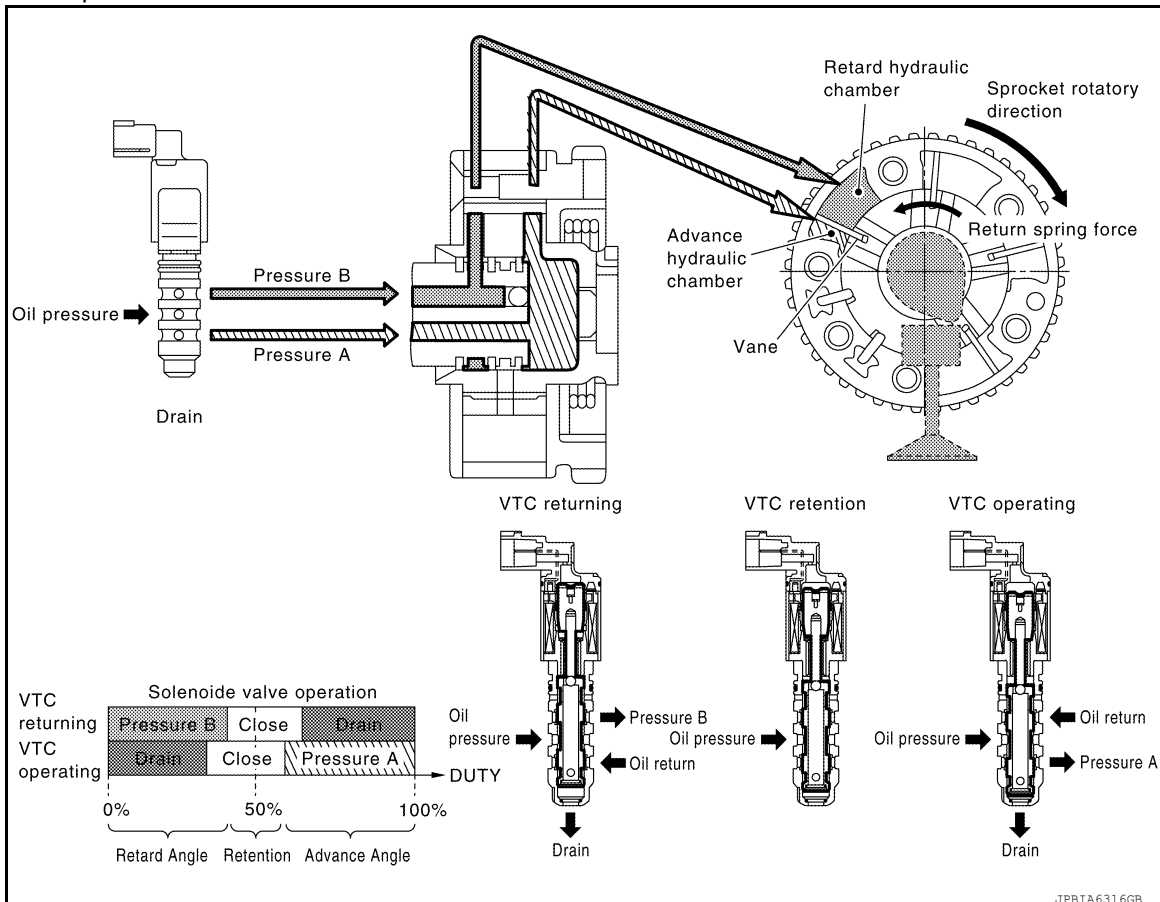

# SYSTEM

## < SYSTEM DESCRIPTION >

[QR25DE]

This mechanism hydraulically controls cam phases continuously with the fixed operating angle of the intake valve.

The ECM receives signals such as crankshaft position, camshaft position, engine speed, and engine coolant temperature. Then, the ECM sends ON/OFF pulse duty signals to the intake valve timing (IVT) control solenoid valve depending on driving status. This makes it possible to control the shut/open timing of the intake valve to increase engine torque in low/mid speed range and output in high-speed range.

### INTAKE VALVE TIMING INTERMEDIATE LOCK CONTROL

#### System Diagram

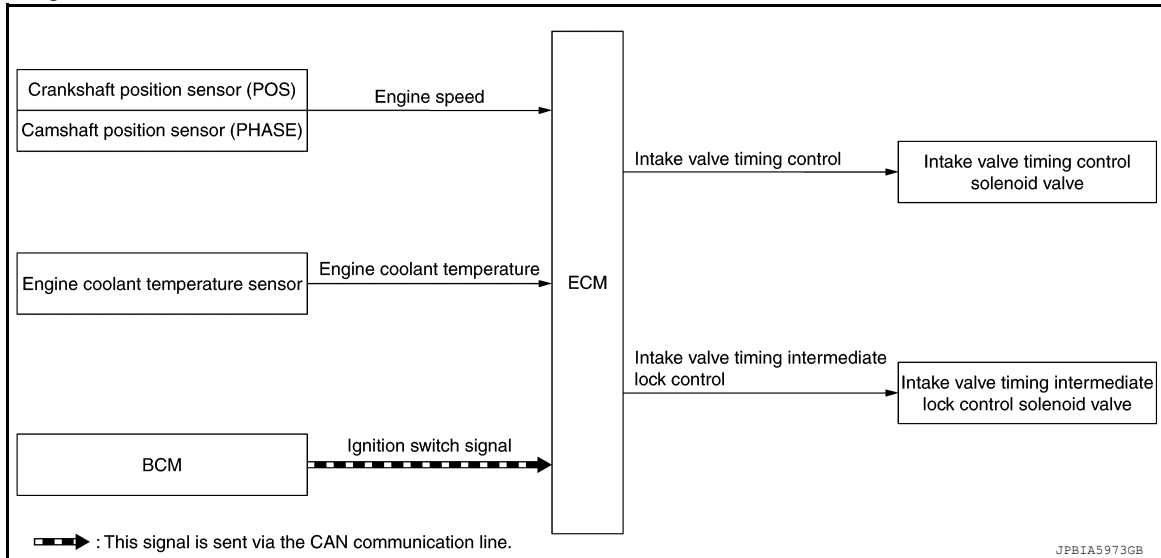

#### System Description

The intake valve timing intermediate lock control improves the cleaning ability of exhaust gas at cold starting by fixing the camshaft sprocket (INT) with two lock keys and bringing the cam phase into intermediate phase.

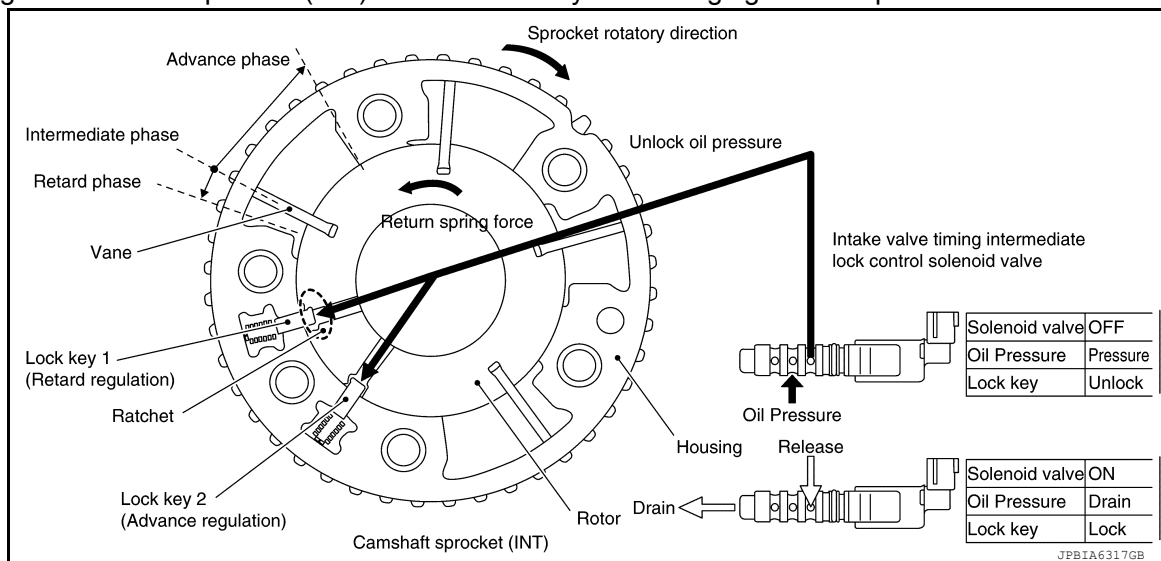

Cam phase is fixed at the intermediate phase by two lock keys in the camshaft sprocket (INT). Lock key 1 controls retard position and lock key 2 controls advance position.

ECM controls the intermediate phase lock by opening/closing the intake valve timing intermediate lock control solenoid valve to control oil pressure acting on the lock key and locking/unlocking the lock key.

#### Lock/Unlock Activation

When ECM activates the intake valve timing intermediate lock control solenoid valve, oil pressure generated in the oil pump is drained through the oil pressure path in the control valve. Since oil pressure is not acted on the lock key, the lock key position is fixed by the spring tension and the cam phase is fixed at the intermediate phase.

When ECM deactivates the intake valve timing intermediate lock control solenoid valve, unlocking oil pressure acts on each lock key. Lock key 1 is not released because it is under load due to sprocket rotational force. For

this reason, lock key 2 is released first by being pushed up by unlocking oil pressure. When lock key 2 is released, some clearance is formed between lock key 1 and the rotor due to sprocket rotational force and return spring force. Accordingly, lock key 1 is pushed up by unlocking oil pressure and the intermediated phase lock is released.

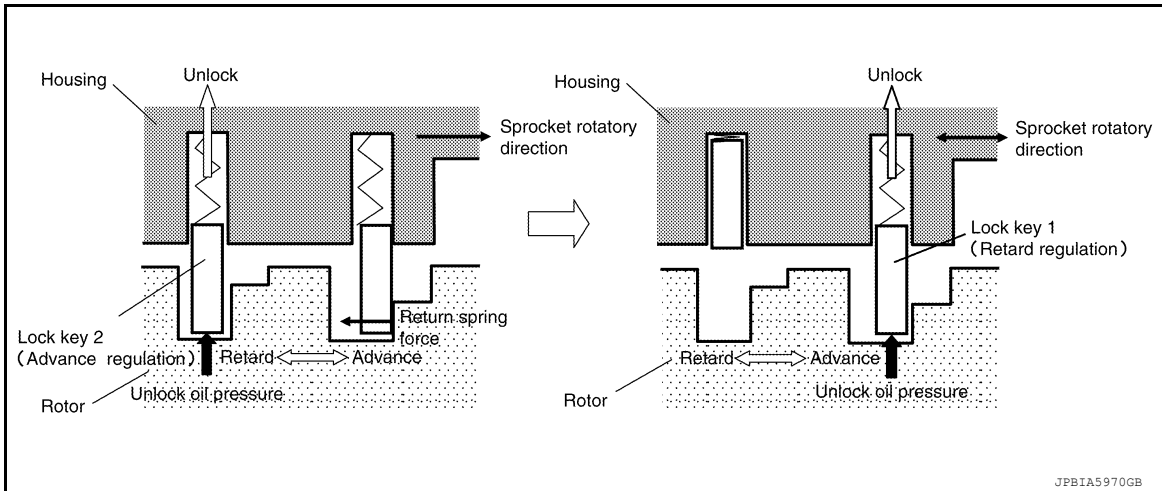

**When stopping the engine**

When the ignition switch is turned from idle state to OFF, ECM receives an ignition switch signal from BCM via CAN communication and activates the intake valve timing intermediate lock control solenoid valve and drains oil pressure acting on the lock key before activating the intake valve timing control solenoid valve and operating the cam phase toward the advance position.

The cam phase is fixed by the lock key when shifting to the intermediated phase and ECM performs Lock judgment to stop the engine.

**When starting the engine**

When starting the engine by cold start, ECM judges the locked/unlocked state when ignition switch is turned ON. When judged as locked state (fixed at the intermediate phase), the intake valve timing intermediate lock control solenoid valve is activated. Since oil pressure does not act on the lock key even when the engine is started, the cam phase is fixed at the intermediate phase and the intake valve timing control is not performed.

When the engine stops without locking the cam phase at the intermediate phase due to an engine stall and the state is not judged as locked, the intake valve timing intermediate lock control solenoid valve and the intake valve timing control solenoid valve are activated and the cam phase shifts to the advanced position to be locked at the intermediate phase. Even when not locked in the intermediate lock phase due to no oil pressure or low oil pressure, a ratchet structure of the camshaft sprocket (INT) rotor allows the conversion to the intermediate phase in stages by engine vibration.

When engine coolant temperature is more than 60°C, the intake valve timing is controlled by deactivating the intake valve timing intermediate lock control solenoid valve and releasing the intermediate phase lock.

When the engine is started after warming up, ECM releases the intermediate phase lock immediately after the engine start and controls the intake valve timing.

**EXHAUST VALVE TIMING CONTROL**

EXHAUST VALVE TIMING CONTROL : System Description

INFOID:000000011277858

SYSTEM DIAGRAM

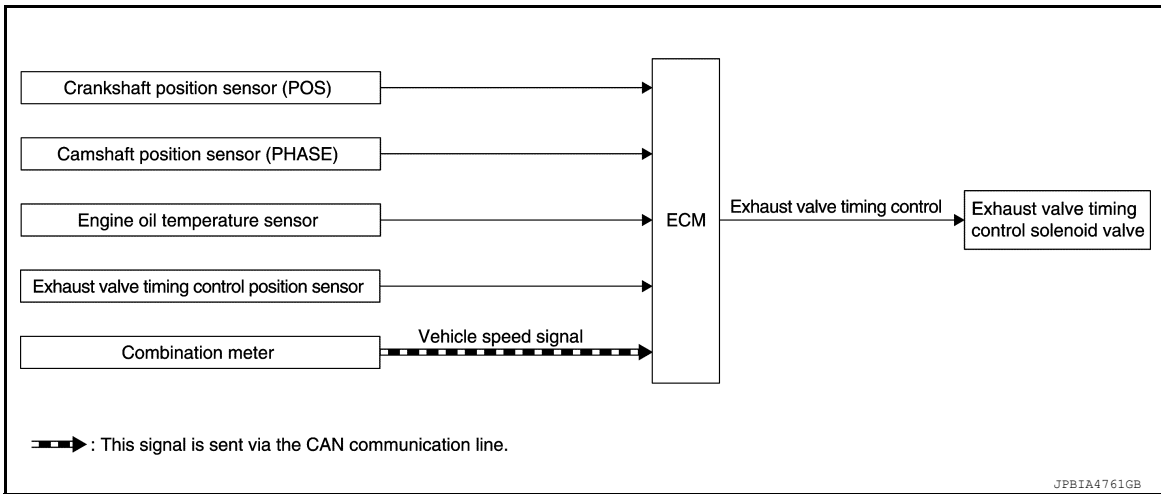

SYSTEM DESCRIPTION

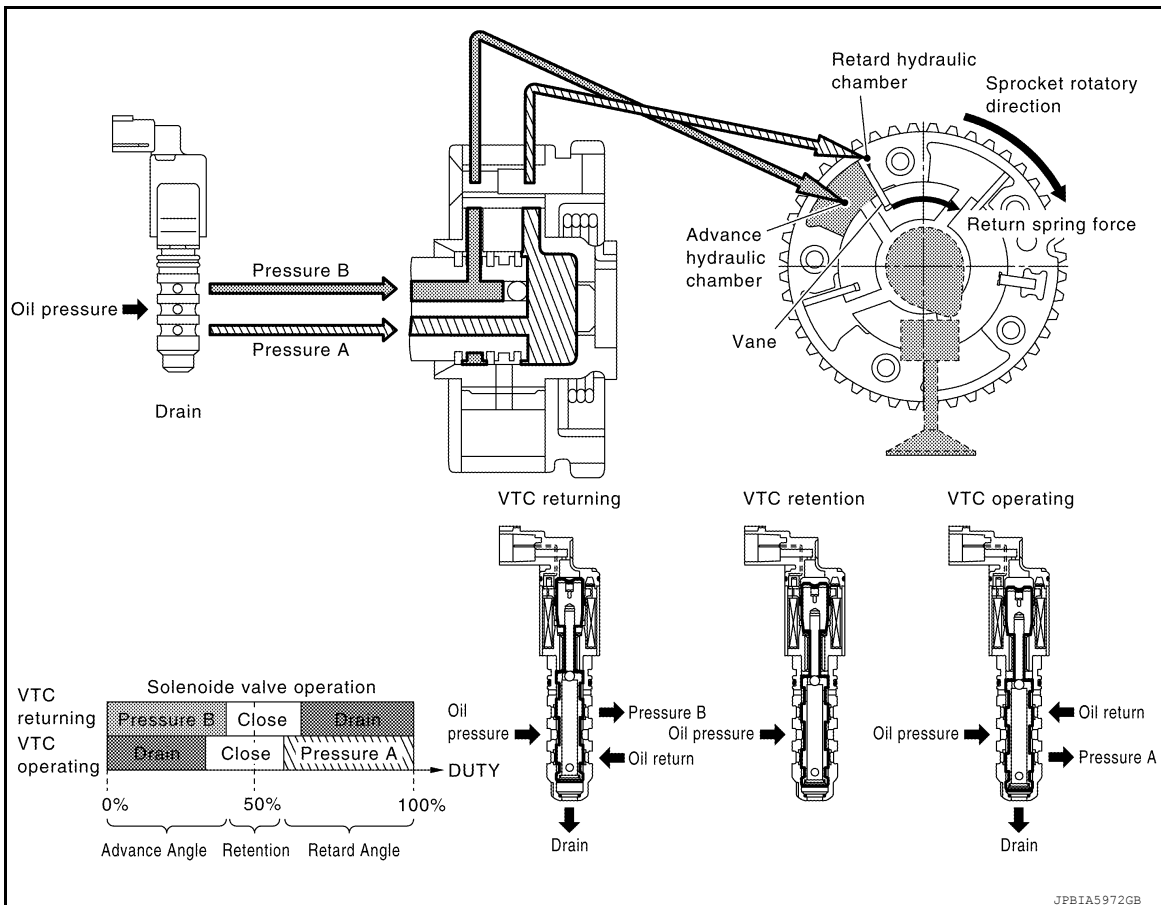

This mechanism hydraulically controls cam phases continuously with the fixed operating angle of the exhaust valve.

The ECM receives signals such as crankshaft position, camshaft position, engine speed, and engine oil temperature. Then, the ECM sends ON/OFF pulse duty signals to the exhaust valve timing (EVT) control solenoid valve depending on driving status. This makes it possible to control the shut/open timing of the exhaust valve to increase engine torque and output in a range of high engine speed.

INTAKE MANIFOLD RUNNER CONTROL

INTAKE MANIFOLD RUNNER CONTROL : System Description

INFOID:000000011277859

SYSTEM DIAGRAM

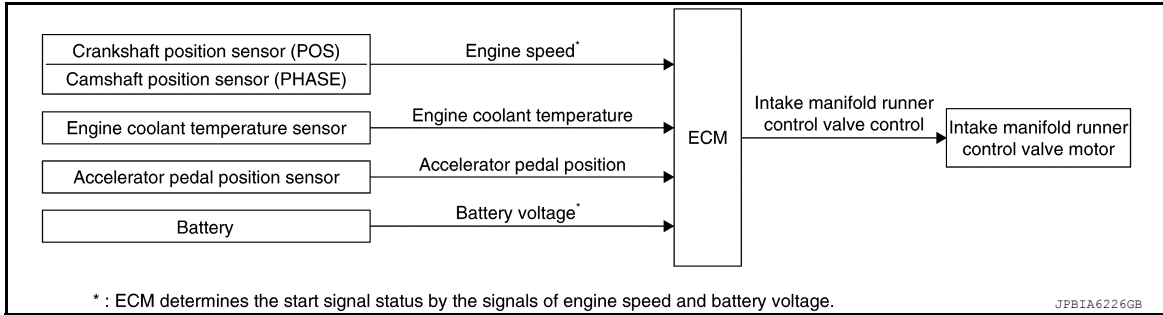

SYSTEM DESCRIPTION

Intake manifold runner control valve has a valve portion in the intake passage of each cylinder. While idling and during low engine coolant temperature, the intake manifold runner control valve closes. Thus the velocity of the air in the intake passage increases, promoting the vaporization of the fuel and producing an intake manifold runner in the combustion chamber. Because of this operation, this system tends to increase the burning speed of the gas mixture, improve exhaust emission, and increase the stability in running conditions. Also, except when idling and during low engine coolant temperature, this system opens the intake manifold runner control valve. In this condition, this system tends to increase power by improving intake efficiency via reduction of intake flow resistance.

The intake manifold runner control valve is operated by the ECM.

ENGINE PROTECTION CONTROL AT LOW ENGINE OIL PRESSURE

ENGINE PROTECTION CONTROL AT LOW ENGINE OIL PRESSURE : System Description

INFOID:000000011277860

SYSTEM DIAGRAM

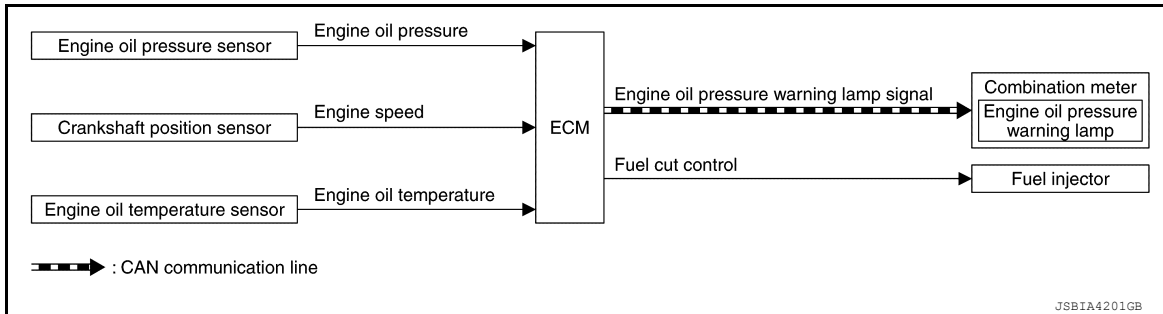

SYSTEM DESCRIPTION

- The engine protection control at low engine oil pressure warns the driver of a decrease in engine oil pressure by the engine oil pressure warning lamp a before the engine becomes damaged.
- When detecting a decrease in engine oil pressure at an engine speed less than 1,000 rpm, ECM transmits an engine oil pressure warning lamp signal to the combination meter. The combination meter turns ON the engine oil pressure warning lamp, according to the signal.

Decrease in engine oil pressure	Engine speed	Combination meter	Fuel cut
		Engine oil pressure warning lamp	
Detection	Less than 1,000 rpm	ON*	NO
	1,000 rpm or more	ON	YES

\*: When detecting a normal engine oil pressure, ECM turns OFF the engine oil pressure warning lamp.

AIR CONDITIONING CUT CONTROL

AIR CONDITIONING CUT CONTROL : System Description

INFOID:000000011277861

SYSTEM DIAGRAM

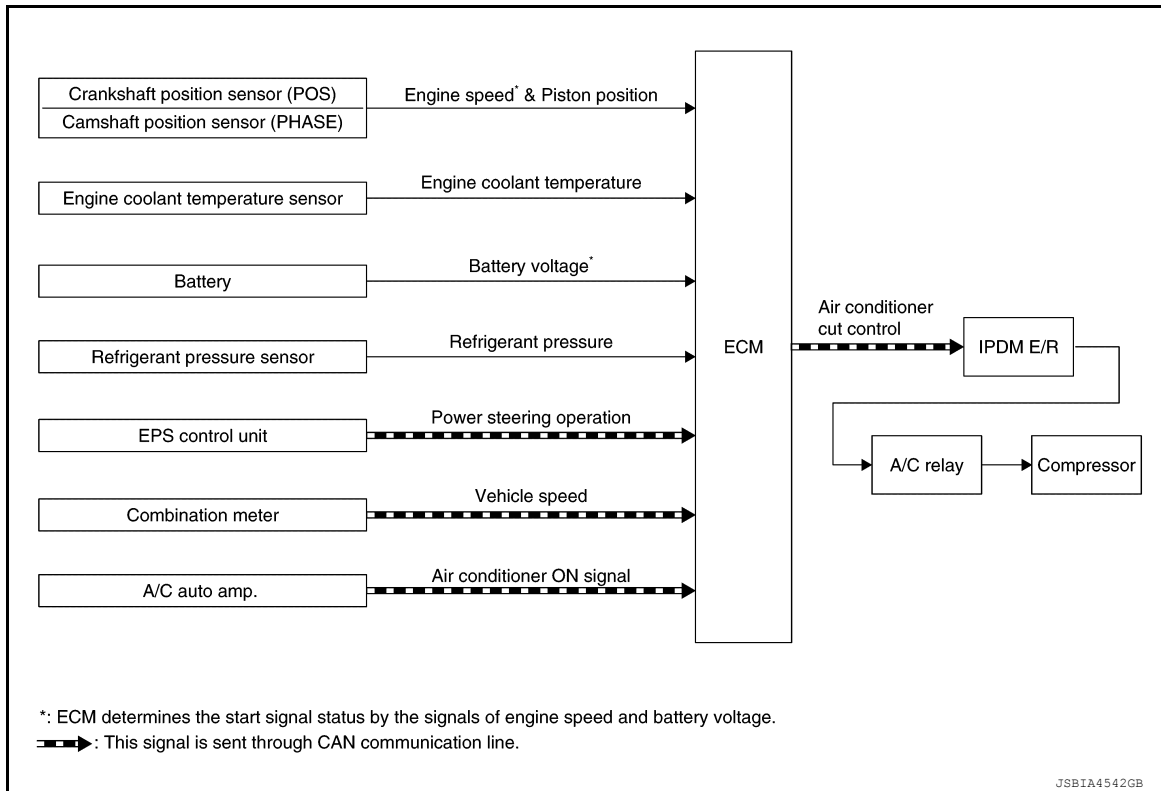

SYSTEM DESCRIPTION

This system improves engine operation when the air conditioner is used. Under the following conditions, the air conditioner is turned off.

- When cranking the engine.
- At high engine speeds.
- When the engine coolant temperature becomes excessively high.
- When operating power steering during low engine speed or low vehicle speed.
- When engine speed is excessively low.
- When refrigerant pressure is excessively low or high.

POWER GENERATION VOLTAGE VARIABLE CONTROL SYSTEM

POWER GENERATION VOLTAGE VARIABLE CONTROL SYSTEM : System Description

INFOID:000000011277862

DESCRIPTION

ECM transmits a target power generation voltage signal received from IPDM E/R to the generator via LIN communication.

The generator includes a self-diagnosis function and transmits a diagnosis signal to ECM via LIN communication when detecting a malfunction. When ECM receives a diagnosis signal, ECM detects DTC and transmits a charge warning lamp request signal to the combination meter to turn ON the charge warning lamp.

COOLING FAN CONTROL

## COOLING FAN CONTROL : System Description

INFOID:000000011277863

### SYSTEM DIAGRAM

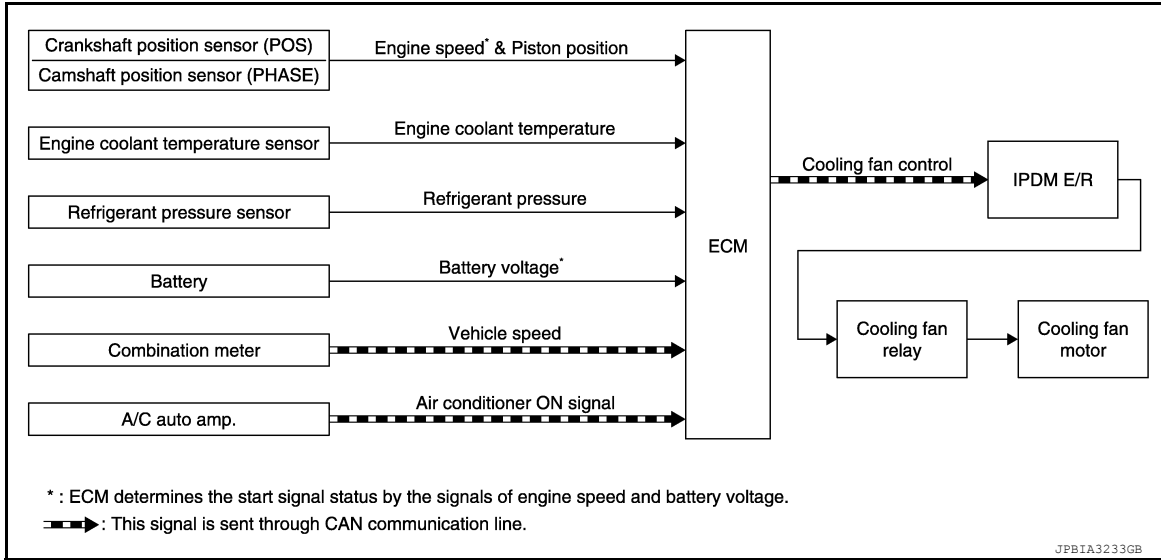

### SYSTEM DESCRIPTION

ECM controls cooling fan speed corresponding to vehicle speed, engine coolant temperature, refrigerant pressure, air conditioner ON signal. Then control system has 3-step control [HIGH/LOW/OFF].

#### Cooling Fan Operation

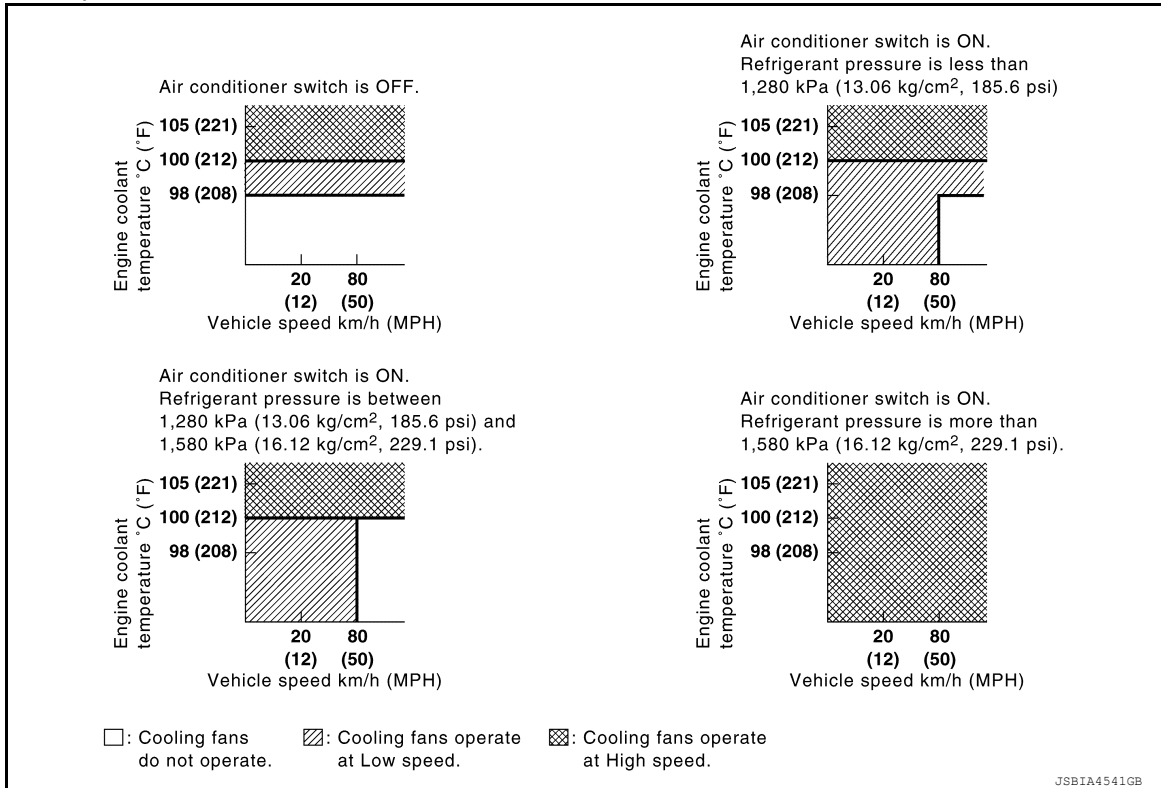

#### Cooling Fan Relay Operation

The ECM controls cooling fan relays through CAN communication line.

Cooling fan speed	Cooling fan relay		
	1	2	3
Stop (OFF)	OFF	OFF	OFF



# SYSTEM

< SYSTEM DESCRIPTION >

[QR25DE]

Cooling fan speed	Cooling fan relay		
	1	2	3
Low (LOW)	OFF	ON	OFF
High (HI)	ON	OFF	ON

## AUTOMATIC SPEED CONTROL DEVICE (ASCD)

### AUTOMATIC SPEED CONTROL DEVICE (ASCD) : System Description

INFOID:0000000011277864

#### SYSTEM DIAGRAM

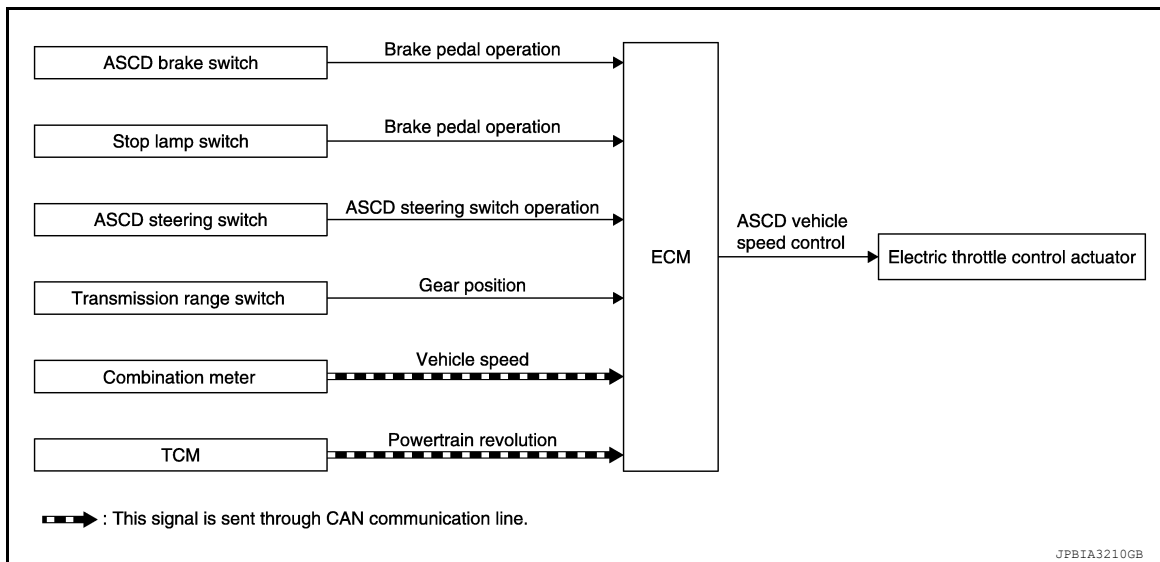

#### BASIC ASCD SYSTEM

Refer to Owner's Manual for ASCD operating instructions.

Automatic Speed Control Device (ASCD) allows a driver to keep vehicle at predetermined constant speed without depressing accelerator pedal. Driver can set vehicle speed in advance between approximately 40 km/h (25 MPH) and 144 km/h (89 MPH).

ECM controls throttle angle of electric throttle control actuator to regulate engine speed.

The ASCD operation status is indicated by two indicators (CRUISE and SET on the information display) on the combination meter. If any malfunction occurs in ASCD system, SET indicator blinks and ASCD control is deactivated.

#### NOTE:

**Always drive vehicle in safe manner according to traffic conditions and obey all traffic laws.**

#### SET OPERATION

Press MAIN switch. (CRUISE is indicated on the information display.)

When vehicle speed reaches a desired speed between approximately 40 km/h (25 MPH) and 144 km/h (89 MPH), press SET/COAST switch. (Then SET is indicated on the information display.)

#### ACCELERATE OPERATION

If the RESUME/ACCELERATE switch is pressed during cruise control driving, increase the vehicle speed until the switch is released or vehicle speed reaches maximum speed controlled by the system.

And then ASCD will keep the new set speed.

#### CANCEL OPERATION

When any of following conditions exist, cruise operation will be canceled.

- CANCEL switch is pressed
- More than 2 switches at ASCD steering switch are pressed at the same time (Set speed will be cleared)
- Brake pedal is depressed
- Selector lever is changed to N, P, R position
- Vehicle speed decreased to 13 km/h (8 MPH) lower than the set speed
- TCS system is operated

When the ECM detects any of the following conditions, the ECM will cancel the cruise operation and inform the driver by blinking indicators.

# SYSTEM

[QR25DE]

## < SYSTEM DESCRIPTION >

- Engine coolant temperature is slightly higher than the normal operating temperature, CRUISE indicator may blink slowly.  
When the engine coolant temperature decreases to the normal operating temperature, CRUISE indicator will stop blinking and the cruise operation will be able to work by pressing SET/COAST switch or RESUME/ACCELERATE switch.
- Malfunction for some self-diagnoses regarding ASCD control: SET indicator will blink quickly.  
If MAIN switch is turned off during ASCD is activated, all of ASCD operations will be canceled and vehicle speed memory will be erased.

### COAST OPERATION

When the SET/COAST switch is pressed during cruise control driving, decrease vehicle set speed until the switch is released. And then ASCD will keep the new set speed.

### RESUME OPERATION

When the RESUME/ACCELERATE switch is pressed after cancel operation other than pressing MAIN switch is performed, vehicle speed will return to last set speed. To resume vehicle set speed, vehicle condition must meet following conditions.

- Brake pedal is released
- Selector lever is in other than P and N positions
- Vehicle speed is greater than 40 km/h (25 MPH) and less than 144 km/h (89 MPH)

## FUEL FILLER CAP WARNING SYSTEM

### FUEL FILLER CAP WARNING SYSTEM : System Description

INFOID:000000011277865

### SYSTEM DIAGRAM

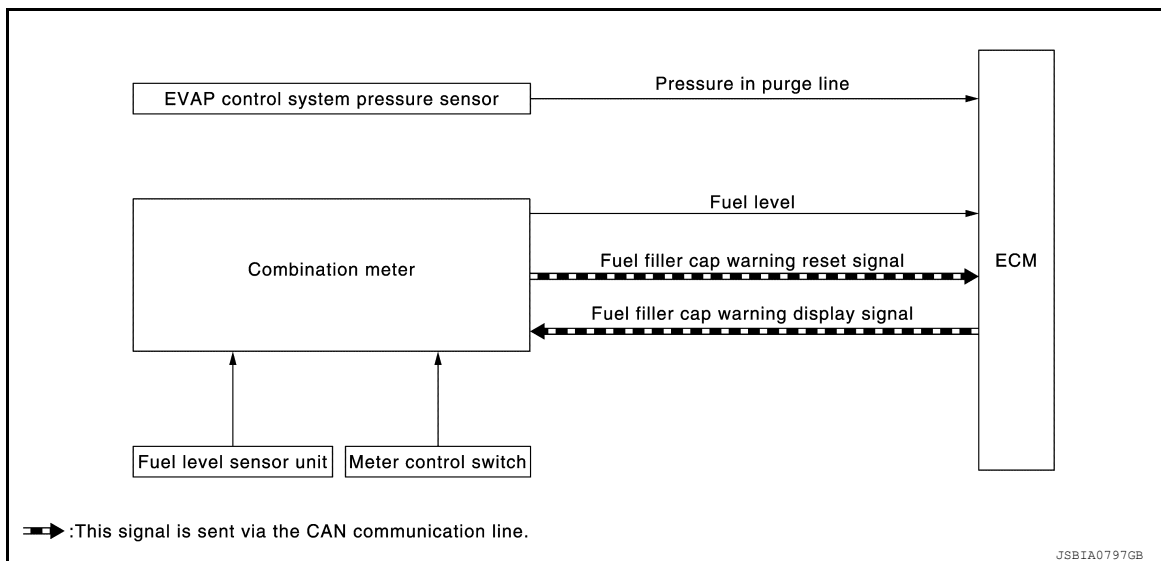

### SYSTEM DESCRIPTION

The fuel filler cap warning system alerts the driver to the prevention of the fuel filler being left uncapped and malfunction occurrences after refueling, by turning ON the fuel filler cap warning display on the combination meter.

ECM judges a refueled state, based on a fuel level signal transmitted from the combination meter.

When a very small leak is detected through the EVAP leak diagnosis performed after judging the refueled state, ECM transmits a fuel filler cap warning display signal (request for display ON) to the combination meter via CAN communication.

When receiving the signal, the combination meter turns ON the fuel filler cap warning display.

#### **CAUTION:**

**Check fuel filler cap installation condition when the fuel filler cap warning display turns ON.**

#### Reset Operation

The fuel filler cap warning lamp turns OFF, according to any condition listed below:

- Reset operation is performed by operating the meter control switch on the combination meter. Refer to [MWI-18, "Switch Name and Function"](#).
- When the reset operation is performed, the combination meter transmits a fuel filler cap warning reset signal to ECM via CAN communication. ECM transmits a fuel filler cap warning display signal (request for display

# SYSTEM

< SYSTEM DESCRIPTION >

[QR25DE]

- OFF) to the combination meter via CAN communication. When receiving the signal, the combination meter turns OFF the fuel filler cap warning display.
- EVAP leak diagnosis result is normal.
  - Fuel refilled.
  - DTC erased by using CONSULT.

**NOTE:**

MIL turns ON if a malfunction is detected in leak diagnosis results again at the trip after the fuel filler cap warning display turns ON/OFF.

## WARNING/INDICATOR/CHIME LIST

### WARNING/INDICATOR/CHIME LIST : Warning lamps/Indicator lamps

INFOID:000000011277866

Name	Arrangement/Function
Malfunction indicator lamp (MIL)	Regarding the function. Refer to <a href="#">EC-51, "WARNING/INDICATOR/CHIME LIST : Malfunction Indicator Lamp (MIL)"</a> .

### WARNING/INDICATOR/CHIME LIST : Warning/Indicator (On Information Display)

INFOID:000000011277867

## WARNING

Name	Arrangement/Function
Engine oil pressure warning	Regarding the function. Refer to <a href="#">EC-53, "WARNING/INDICATOR/CHIME LIST : Engine Oil Pressure Warning"</a> .
Fuel filler cap warning	Regarding the function. Refer to <a href="#">EC-54, "WARNING/INDICATOR/CHIME LIST : Fuel Filler Cap Warning"</a> .

## INDICATOR/INFORMATION

Name	Design	Function
①CRUISE indicator ②SET indicator		<a href="#">EC-49, "AUTOMATIC SPEED CONTROL DEVICE (ASCD) : System Description"</a>

JSBIA34592Z

### WARNING/INDICATOR/CHIME LIST : Malfunction Indicator Lamp (MIL)

INFOID:000000011277868

## DESIGN/PURPOSE

When a malfunction which increases exhaust gases is detected, ECM turns ON MIL and informs the driver of the necessity of inspection and repair.

# SYSTEM

[QR25DE]

## < SYSTEM DESCRIPTION >

When a malfunction which causes damage to the catalyst is detected, ECM immediately blinks MIL to alert the driver.

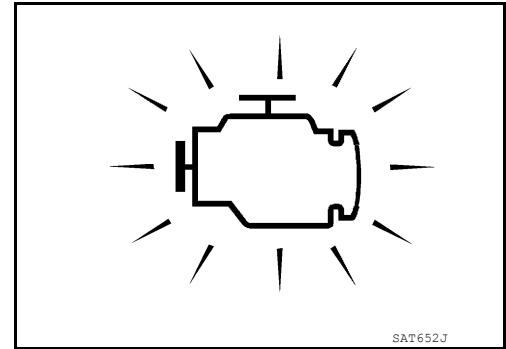

## BULB CHECK

The bulb turns ON after turning ON the ignition switch (engine stop) and turns OFF after restarting the engine.

## OPERATION AT COMBINATION METER CAN COMMUNICATION CUT-OFF OR UNUSUAL SIGNAL

For the operation for CAN communication blackout in the combination meter, refer to [MWI-30. "Fail-safe"](#).

## SYSTEM DIAGRAM

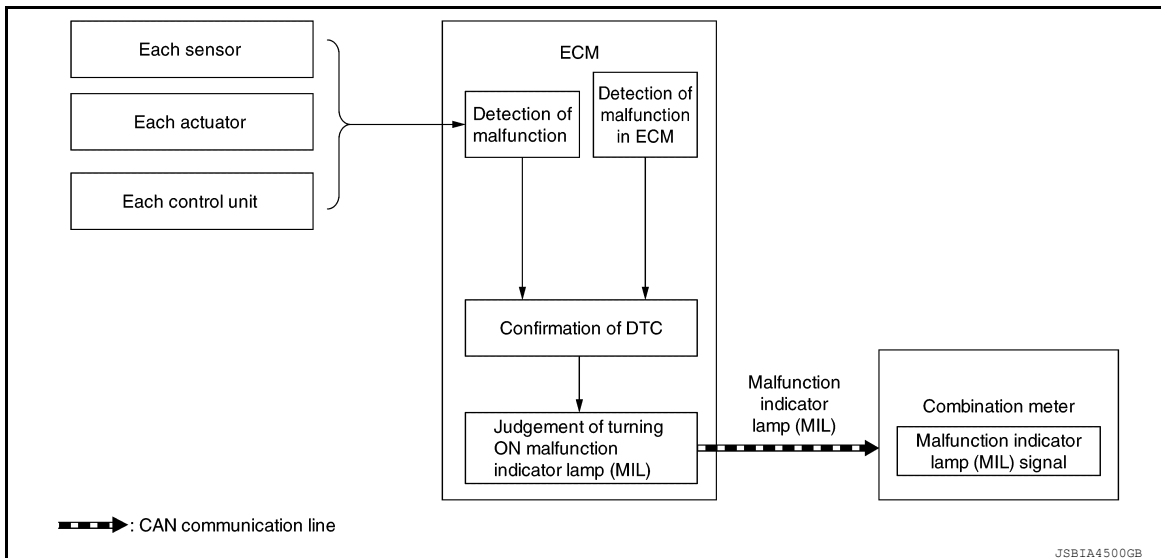

## SIGNAL PATH

- When the lighting conditions of the malfunction indicator lamp (MIL) are satisfied, ECM transmits a malfunction indicator lamp (MIL) signal to the combination meter via CAN communication.
- The combination meter turns ON or blinks the malfunction indicator lamp (MIL), according to a signal received from ECM.

## LIGHTING CONDITION

When all of the following conditions are satisfied:

- Ignition switch: ON
- DTC which influences on exhaust gasses is judged.

For DTCs that the malfunction indicator lamp turns ON and the number of DTC diagnosis trips, refer to [EC-96. "DTC Index"](#).

## SHUTOFF CONDITION

When any of the following conditions is satisfied:

- Ignition switch: OFF
- Erase DTC

### NOTE:

For the conditions of erasing DTC, refer to [EC-59. "DIAGNOSIS DESCRIPTION : DTC and Freeze Frame Data"](#).

TIMING CHART

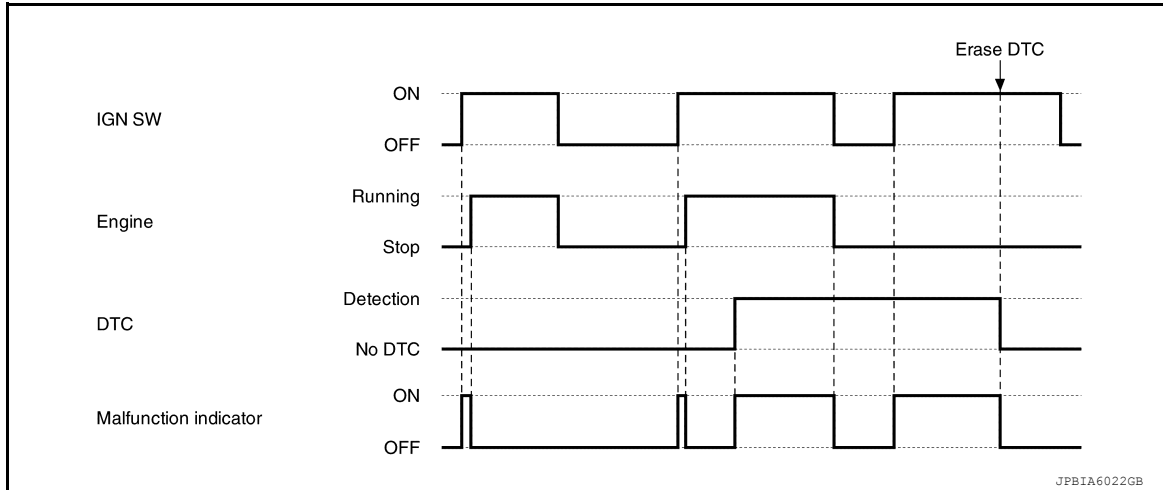

WARNING/INDICATOR/CHIME LIST : Engine Oil Pressure Warning

INFOID:000000011277869

DESIGN/PURPOSE

When engine oil pressure is low, the engine oil pressure warning informs the driver of low oil pressure to prevent damage to the engine.

Symbol	Message
<p>JPNIA1881ZZ</p>	<ul style="list-style-type: none"> <li>• Low oil pressure: See owner's Manual</li> </ul>

BULB CHECK

Not applicable

OPERATION AT COMBINATION METER CAN COMMUNICATION CUT-OFF OR UNUSUAL SIGNAL

For the operation for CAN communications blackout or abnormal signal reception, refer to [MWI-30. "Fail-safe"](#).

SYSTEM DIAGRAM

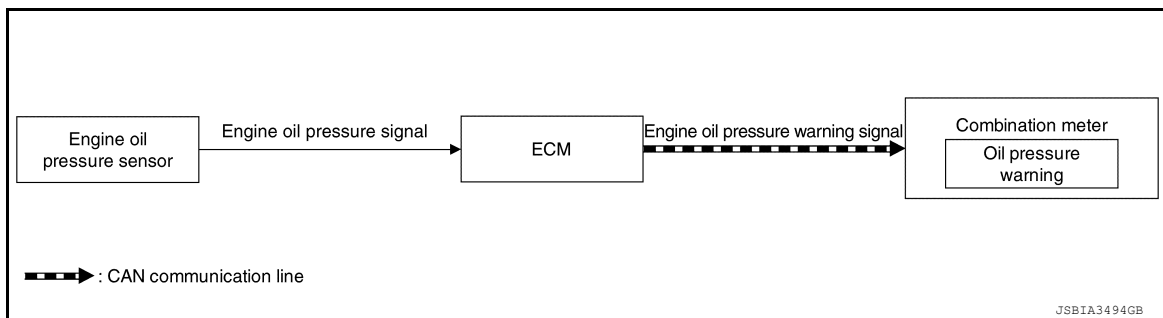

SIGNAL PATH

ECM calculates an engine oil pressure according to a signal transmitted from the engine oil pressure sensor. After engine running when the engine oil pressure is low and at least 5 seconds, ECM transmits the engine oil

# SYSTEM

[QR25DE]

## < SYSTEM DESCRIPTION >

pressure warning signal to combination meter via CAN communication. Then the engine oil pressure warning displays.

### LIGHTING CONDITION

When all of the following conditions for at least 5 seconds are satisfied:

- Ignition switch: ON
- Engine oil pressure is less than specified value.
- Engine speed is more than 500 rpm.

### SHUTOFF CONDITION

When any of the following conditions is satisfied:

- Ignition switch: OFF
- Engine oil pressure is the specified value or more.
- Engine speed is less than 500 rpm.

### TIMING CHART

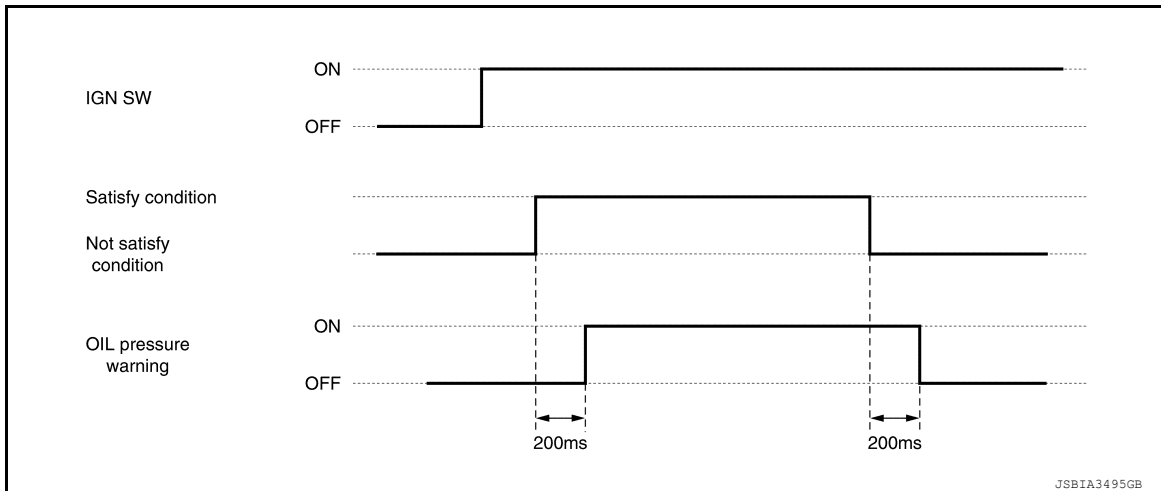

## WARNING/INDICATOR/CHIME LIST : Fuel Filler Cap Warning

INFOID:000000011277870

### DESIGN/PURPOSE

Warn the driver that the fuel filler cap is left opened.

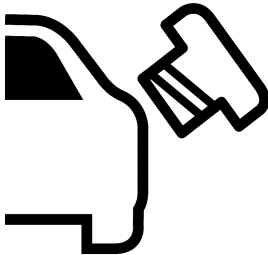
Symbol	Message
 <p style="text-align: right; font-size: small;">JSBIA3176GB</p>	<p>Loose Fuel Cap</p>

For details, refer to [EC-50. "FUEL FILLER CAP WARNING SYSTEM : System Description"](#).

## EVAPORATIVE EMISSION SYSTEM

# SYSTEM

< SYSTEM DESCRIPTION >

[QR25DE]

## EVAPORATIVE EMISSION SYSTEM : System Description

INFOID:000000011277871

### SYSTEM DIAGRAM

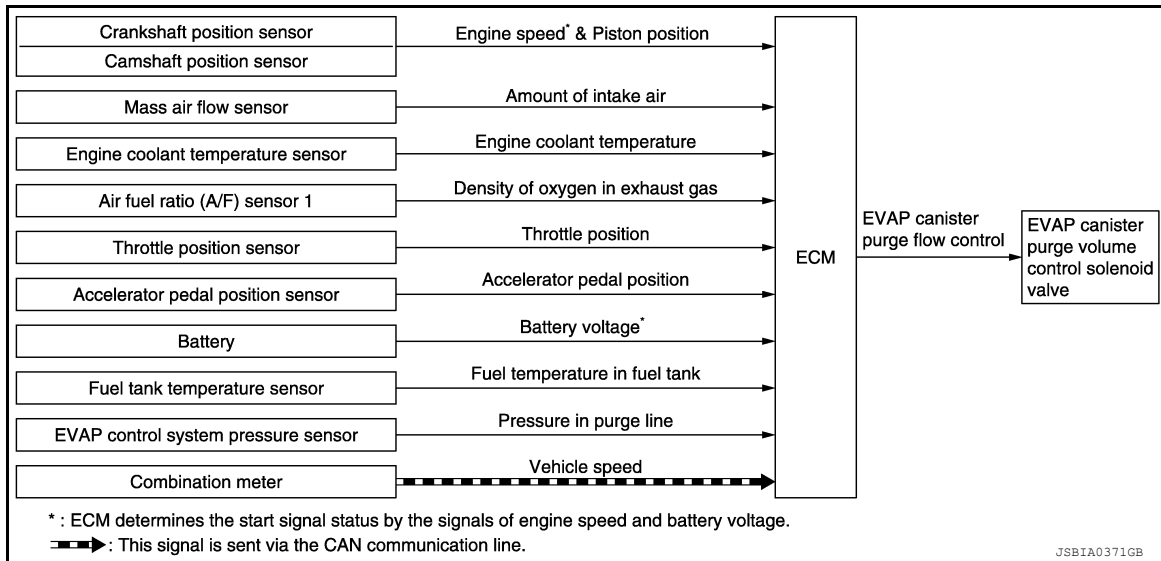

### SYSTEM DESCRIPTION

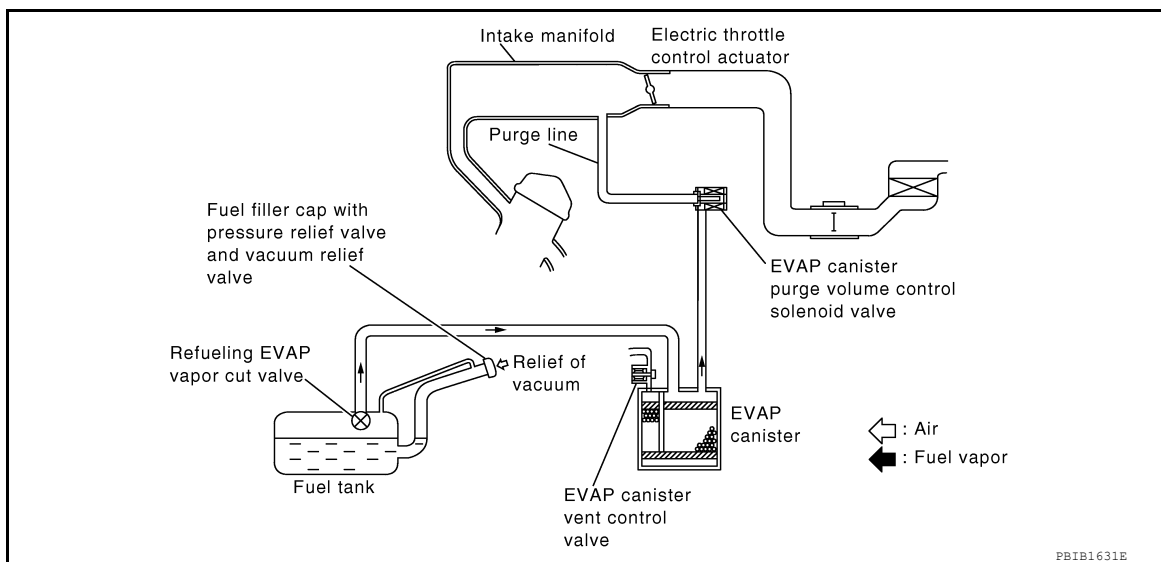

The evaporative emission system is used to reduce hydrocarbons emitted into the atmosphere from the fuel system. This reduction of hydrocarbons is accomplished by activated charcoals in the EVAP canister. The fuel vapor in the sealed fuel tank is led into the EVAP canister which contains activated carbon and the vapor is stored there when the engine is not operating or when refueling to the fuel tank. The vapor in the EVAP canister is purged by the air through the purge line to the intake manifold when the engine is operating. EVAP canister purge volume control solenoid valve is controlled by ECM. When the engine operates, the flow rate of vapor controlled by EVAP canister purge volume control solenoid valve is proportionally regulated as the air flow increases. EVAP canister purge volume control solenoid valve also shuts off the vapor purge line during decelerating.

### CAN COMMUNICATION

#### CAN COMMUNICATION : System Description

INFOID:000000011277872

CAN (Controller Area Network) is a serial communication line for real time application. It is an on-vehicle multiplex communication line with high data communication speed and excellent error detection ability. Many electronic control units are equipped onto a vehicle, and each control unit shares information and links with other control units during operation (not independent). In CAN communication, control units are connected with 2 communication lines (CAN H line, CAN L line) allowing a high rate of information transmission with less wiring. Each control unit transmits/receives data but selectively reads required data only.

# SYSTEM

< SYSTEM DESCRIPTION >

[QR25DE]

Refer to [LAN-32. "CAN COMMUNICATION SYSTEM : CAN Communication Signal Chart"](#), about CAN communication for detail.

## SPORT MODE CONTROL

### SPORT MODE CONTROL : System Description

INFOID:000000011277873

#### SYSTEM DIAGRAM

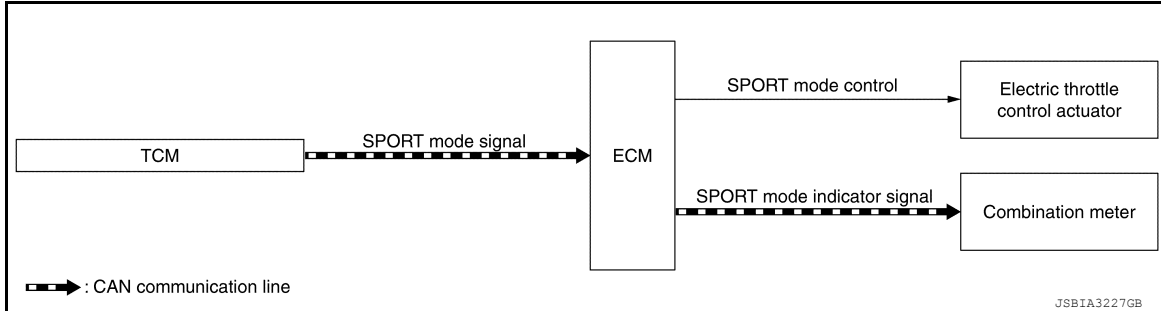

#### SYSTEM DESCRIPTION

- SPORT mode that keeps high engine revolution and provides direct feel and acceleration performance suitable for driving on winding road.
- ECM receives an SPORT mode signal from TCM via CAN communication and improves drivability by controlling the throttle movement.
- ECM transmits an SPORT mode indicator lamp signal to the combination meter via CAN communication.

**NOTE:**

For the details of the SPORT mode, refer to [DMS-8. "SPORT MODE CONTROL : System Description"](#).

## ECO MODE CONTROL

### ECO MODE CONTROL : System Description

INFOID:000000011518220

#### SYSTEM DESCRIPTION

ECM receives an ECO mode signal from TCM via CAN communication and improves the fuel economy by controlling the throttle movement to less than usual.

For details of ECO mode system, refer to [TM-43. "ECO MODE SYSTEM : System Description"](#).



# OPERATION

< SYSTEM DESCRIPTION >

[QR25DE]

## OPERATION

### AUTOMATIC SPEED CONTROL DEVICE (ASCD)

### AUTOMATIC SPEED CONTROL DEVICE (ASCD) : Switch Name and Function

INFOID:000000011277874

#### SWITCHES AND INDICATORS

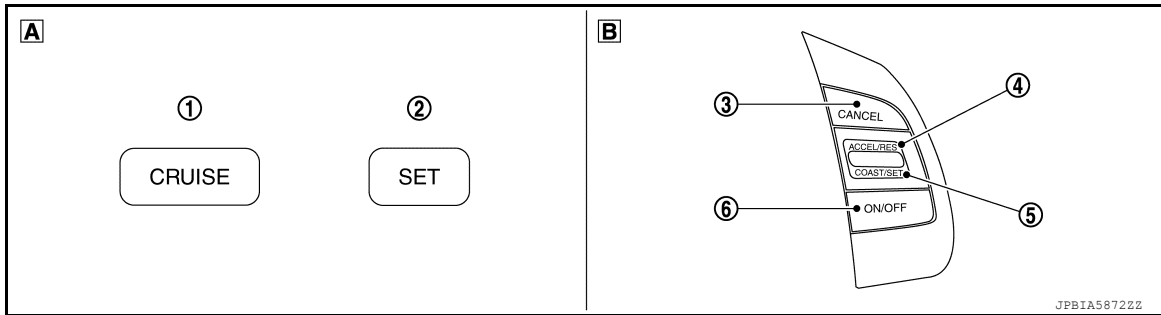

**A** On the combination meter

**B** On the steering wheel

① CRUISE indicator

② SET indicator

③ CANCEL switch

④ ACCEL/RES switch

⑤ COAST/SET switch

⑥ ASCD MAIN switch

#### SET SPEED RANGE

ASCD system can be set the following vehicle speed.

Minimum speed (Approx.)	Maximum speed (Approx.)
40 km/h (25 MPH)	144 km/h (90 MPH)

#### SWITCH OPERATION

Item	Function
CANCEL switch	Cancels the cruise control driving.
ACCEL/RES switch	<ul style="list-style-type: none"> <li>Resumes the set speed.</li> <li>Increases speed incrementally during cruise control driving.</li> </ul>
COAST/SET switch	<ul style="list-style-type: none"> <li>Sets desired cruise speed.</li> <li>Decreases speed incrementally during cruise control driving.</li> </ul>
ASCD MAIN switch	Master switch to activate the ASCD system.

Refer to [EC-49. "AUTOMATIC SPEED CONTROL DEVICE \(ASCD\) : System Description"](#) for ASCD operating instructions.

# ON BOARD DIAGNOSTIC (OBD) SYSTEM

< SYSTEM DESCRIPTION >

[QR25DE]

---

## ON BOARD DIAGNOSTIC (OBD) SYSTEM

### Diagnosis Description

INFOID:000000011277875

This system is an on board diagnostic system that records exhaust emission-related diagnostic information and detects a sensors/actuator-related malfunction. A malfunction is indicated by the malfunction indicator lamp (MIL) and stored in control module memory as a DTC. The diagnostic information can be obtained with the diagnostic tool (GST: Generic Scan Tool).

### GST (Generic Scan Tool)

INFOID:000000011277876

When GST is connected with a data link connector equipped on the vehicle side, it will communicate with the control module equipped in the vehicle and then enable various kinds of diagnostic tests. Refer to [EC-58, "Diagnosis Description"](#).

**NOTE:**

Service \$0A is not applied for regions where it is not mandated.

# DIAGNOSIS SYSTEM (ECM)

< SYSTEM DESCRIPTION >

[QR25DE]

## DIAGNOSIS SYSTEM (ECM)

### DIAGNOSIS DESCRIPTION

#### DIAGNOSIS DESCRIPTION : 1st Trip Detection Logic and Two Trip Detection Logic

INFOID:000000011277877

When a malfunction is detected for the first time, 1st trip DTC and 1st trip Freeze Frame data are stored in the ECM memory. The MIL will not illuminate at this stage. <1st trip>

If the same malfunction is detected again during the next drive, the DTC and Freeze Frame data are stored in the ECM memory, and the MIL illuminates. The MIL illuminates at the same time when the DTC is stored. <2nd trip> The "trip" in the "Two Trip Detection Logic" means a driving mode in which self-diagnosis is performed during vehicle operation. Specific on board diagnostic items will cause the ECM to illuminate or blink the MIL, and store DTC and Freeze Frame data, even in the 1st trip, as shown below.

×: Applicable —: Not applicable

Items	MIL				DTC		1st trip DTC	
	1st trip		2nd trip		1st trip displaying	2nd trip displaying	1st trip displaying	2nd trip displaying
	Blinking	Illuminated	Blinking	Illuminated				
Misfire (Possible three way catalyst damage) — DTC: P0300 – P0304 is being detected	×	—	—	—	—	—	×	—
Misfire (Possible three way catalyst damage) — DTC: P0300 – P0304 is being detected	—	—	×	—	—	×	—	—
One trip detection diagnoses (Refer to <a href="#">EC-96, "DTC Index"</a> .)	—	×	—	—	×	—	—	—
Except above	—	—	—	×	—	×	×	—

#### DIAGNOSIS DESCRIPTION : DTC and Freeze Frame Data

INFOID:000000011277878

##### DTC AND 1ST TRIP DTC

The 1st trip DTC (whose number is the same as the DTC number) is displayed for the latest self-diagnostic result obtained. If the ECM memory was cleared previously, and the 1st trip DTC did not recur, the 1st trip DTC will not be displayed.

If a malfunction is detected during the 1st trip, the 1st trip DTC is saved in the ECM memory. The MIL will not light up (two trip detection logic). If the same malfunction is not detected in the 2nd trip (meeting the required driving pattern), the 1st trip DTC is cleared from the ECM memory. If the same malfunction is detected in the 2nd trip, both the 1st trip DTC and DTC are saved in the ECM memory and the MIL lights up. In other words, the DTC is stored in the ECM memory and the MIL lights up when the same malfunction occurs in two consecutive trips. If a 1st trip DTC is stored and a non-diagnostic operation is performed between the 1st and 2nd trips, only the 1st trip DTC will continue to be stored. For malfunctions that blink or light up the MIL during the 1st trip, the DTC and 1st trip DTC are stored in the ECM memory.

For malfunctions in which 1st trip DTCs are displayed, refer to [EC-96, "DTC Index"](#). These items are required by legal regulations to continuously monitor the system/component. In addition, the items monitored non-continuously are also displayed on CONSULT.

1st trip DTC is specified in Service \$07 of SAE J1979/ISO 15031-5. 1st trip DTC detection occurs without illuminating the MIL and therefore does not warn the driver of a malfunction.

When a 1st trip DTC is detected, check, print out or write down and erase (1st trip) DTC and Freeze Frame data as specified in Work Flow procedure Step 2, refer to [EC-130, "Work Flow"](#). Then perform DTC Confirmation Procedure or Component Function Check to try to duplicate the malfunction. If the malfunction is duplicated, the item requires repair.

##### FREEZE FRAME DATA AND 1ST TRIP FREEZE FRAME DATA

The ECM records the driving conditions such as fuel system status, calculated load value, engine coolant temperature, short term fuel trim, long term fuel trim, engine speed, vehicle speed, absolute throttle position, base fuel schedule and intake air temperature at the moment a malfunction is detected.

Data which are stored in the ECM memory, along with the 1st trip DTC, are called 1st trip freeze frame data. The data, stored together with the DTC data, are called freeze frame data and displayed on CONSULT or GST. The 1st trip freeze frame data can only be displayed on the CONSULT screen.

# DIAGNOSIS SYSTEM (ECM)

[QR25DE]

## < SYSTEM DESCRIPTION >

Only one set of freeze frame data (either 1st trip freeze frame data or freeze frame data) can be stored in the ECM. 1st trip freeze frame data is stored in the ECM memory along with the 1st trip DTC. There is no priority for 1st trip freeze frame data and it is updated each time a different 1st trip DTC is detected. However, once freeze frame data (2nd trip detection/MIL on) is stored in the ECM memory, 1st trip freeze frame data is no longer stored. Remember, only one set of freeze frame data can be stored in the ECM. The ECM has the following priorities to update the data.

Priority	Items	
1	Freeze frame data	Misfire — DTC: P0300 – P0304 Fuel Injection System Function — DTC: P0171, P0172
2		Except the above items
3	1st trip freeze frame data	

For example, the EGR malfunction (Priority: 2) was detected and the freeze frame data was saved in the 2nd trip. After that when the misfire (Priority: 1) is detected in another trip, the freeze frame data will be updated from the EGR malfunction to the misfire. The 1st trip freeze frame data is updated each time a different malfunction is detected. There is no priority for 1st trip freeze frame data. However, once freeze frame data is stored in the ECM memory, 1st trip freeze data is no longer stored (because only one freeze frame data or 1st trip freeze frame data can be stored in the ECM). If freeze frame data is stored in the ECM memory and freeze frame data with the same priority occurs later, the first (original) freeze frame data remains unchanged in the ECM memory.

Both 1st trip freeze frame data and freeze frame data (along with the DTCs) are cleared when the ECM memory is erased.

## DIAGNOSIS DESCRIPTION : Counter System

INFOID:00000001127879

### RELATIONSHIP BETWEEN MIL, 1ST TRIP DTC, DTC, AND DETECTABLE ITEMS

- When a malfunction is detected for the first time, the 1st trip DTC and the 1st trip freeze frame data are stored in the ECM memory.
- When the same malfunction is detected in two consecutive trips, the DTC and the freeze frame data are stored in the ECM memory, and the MIL will come on.
- The MIL will turn OFF after the vehicle is driven 3 times (driving pattern B) with no malfunction. The drive is counted only when the recorded driving pattern is met (as stored in the ECM). If another malfunction occurs while counting, the counter will reset.
- The DTC and the freeze frame data will be stored until the vehicle is driven 40 times (driving pattern A) without the same malfunction recurring (except for Misfire and Fuel Injection System). For Misfire and Fuel Injection System, the DTC and freeze frame data will be stored until the vehicle is driven 80 times (driving pattern C) without the same malfunction recurring. The “TIME” in “SELF-DIAGNOSTIC RESULTS” mode of CONSULT will count the number of times the vehicle is driven.
- The 1st trip DTC is not displayed when the self-diagnosis results in OK for the 2nd trip.

### COUNTER SYSTEM CHART

Items	Fuel Injection System	Misfire	Other
MIL (turns OFF)	3 (pattern B)	3 (pattern B)	3 (pattern B)
DTC, Freeze Frame Data (no display)	80 (pattern C)	80 (pattern C)	40 (pattern A)
1st Trip DTC (clear)	1 (pattern C), *1	1 (pattern C), *1	1 (pattern B)
1st Trip Freeze Frame Data (clear)	*1, *2	*1, *2	1 (pattern B)

For details about patterns B and C under “Fuel Injection System” and “Misfire”, see “EXPLANATION FOR DRIVING PATTERNS FOR “MISFIRE <EXHAUST QUALITY DETERIORATION>”, “FUEL INJECTION SYSTEM”.

For details about patterns A and B under Other, see “EXPLANATION FOR DRIVING PATTERNS FOR “MISFIRE <EXHAUST QUALITY DETERIORATION>”, “FUEL INJECTION SYSTEM”.

- \*1: Clear timing is at the moment OK is detected.
- \*2: Clear timing is when the same malfunction is detected in the 2nd trip.

Relationship Between MIL, DTC, 1st Trip DTC and Driving Patterns for “Misfire <Exhaust Quality Deterioration>”, “Fuel Injection System”

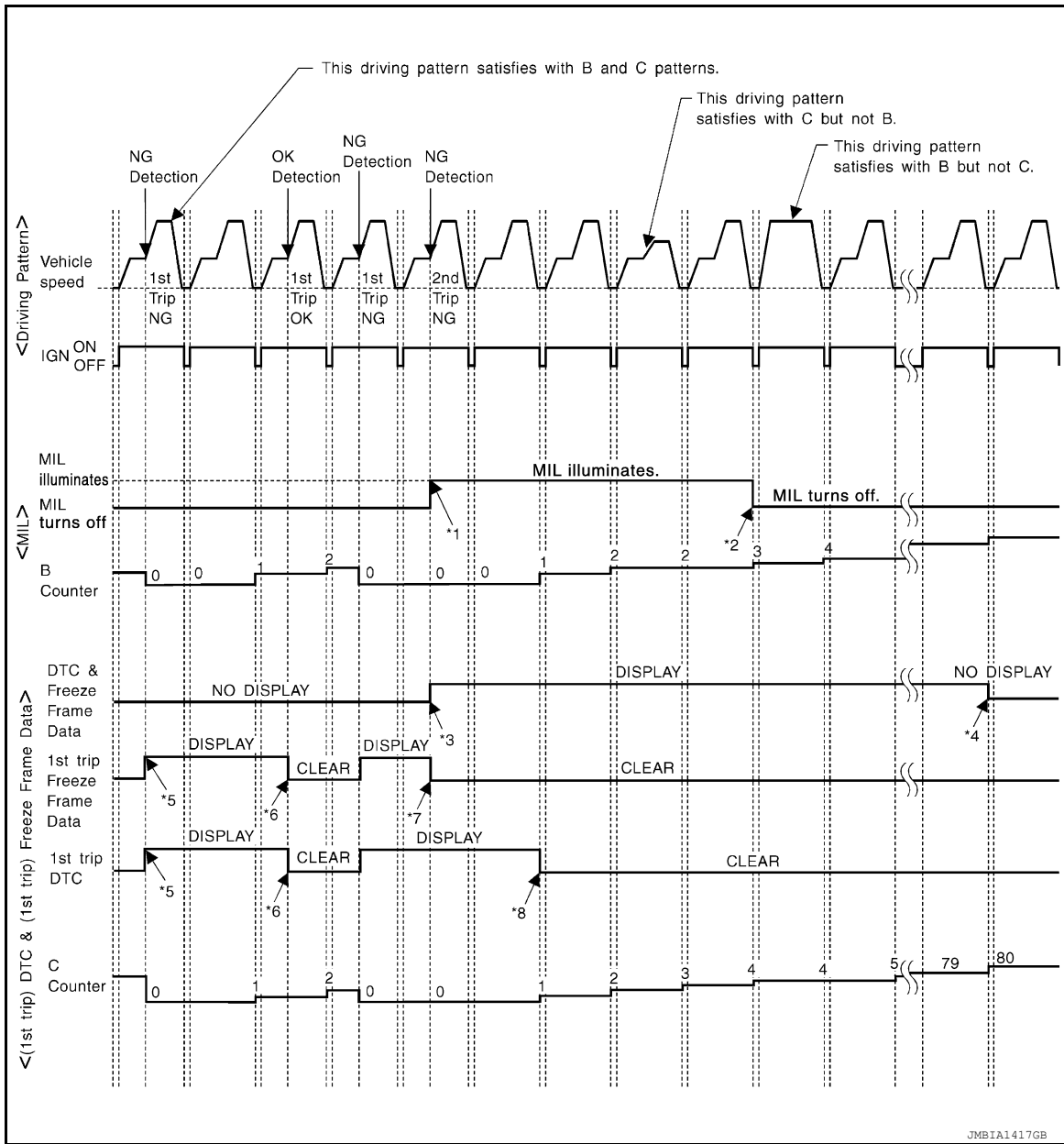

\*1: When the same malfunction is detected in two consecutive trips, MIL will light up.

\*2: MIL will turn OFF after vehicle is driven 3 times (pattern B) without any malfunctions.

\*3: When the same malfunction is detected in two consecutive trips, the DTC and the freeze frame data will be stored in ECM.

\*4: The DTC and the freeze frame data will not be displayed any longer after vehicle is driven 80 times (pattern C) without the same malfunction. (The DTC and the freeze frame data still remain in ECM.)

\*5: When a malfunction is detected for the first time, the 1st trip DTC and the 1st trip freeze frame data will be stored in ECM.

\*6: The 1st trip DTC and the 1st trip freeze frame data will be cleared at the moment OK is detected.

\*7: When the same malfunction is detected in the 2nd trip, the 1st trip freeze frame data will be cleared.

\*8: 1st trip DTC will be cleared when vehicle is driven once (pattern C) without the same malfunction after DTC is stored in ECM.

## Explanation for Driving Patterns for "Misfire <Exhaust Quality Deterioration>", "Fuel Injection System"

### Driving Pattern B

Refer to [EC-63. "DIAGNOSIS DESCRIPTION : Driving Pattern"](#).

# DIAGNOSIS SYSTEM (ECM)

[QR25DE]

## < SYSTEM DESCRIPTION >

### Driving Pattern C

Refer to [EC-63. "DIAGNOSIS DESCRIPTION : Driving Pattern"](#).

Example:

If the stored freeze frame data is as per the following:

Engine speed: 850 rpm, Calculated load value: 30%, Engine coolant temperature: 80°C (176°F)

To be satisfied with driving pattern C, the vehicle should run under the following conditions:

Engine speed: 475 – 1,225 rpm, Calculated load value: 27 – 33%, Engine coolant temperature: more than 70°C (158°F)

Relationship Between MIL, DTC, 1st Trip DTC and Driving Patterns Except For “Misfire <Exhaust Quality Deterioration>”, “Fuel Injection System”

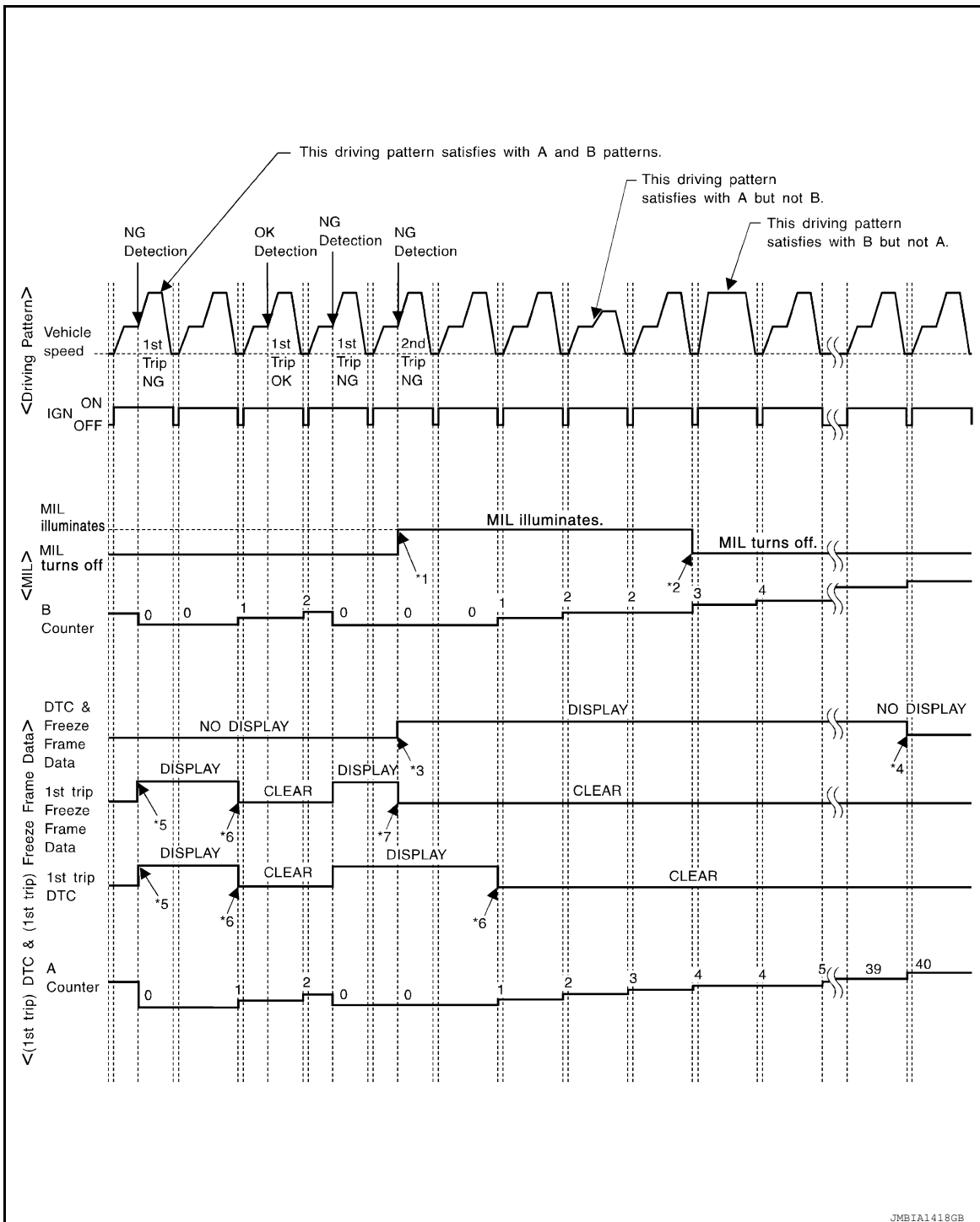

- |   |  |   |    |
|---|--|---|----|
| <p>*1: When the same malfunction is detected in two consecutive trips, MIL will light up.</p>   | <p>*2: MIL will turn OFF after vehicle is driven 3 times (pattern B) without any malfunctions.</p>                                       | <p>*3: When the same malfunction is detected in two consecutive trips, the DTC and the freeze frame data will be stored in ECM.</p> | A  |
| <p>*4: The DTC and the freeze frame data will not be displayed any longer after vehicle is driven 40 times (pattern A) without the same malfunction. (The DTC and the freeze frame data still remain in ECM.)</p> | <p>*5: When a malfunction is detected for the first time, the 1st trip DTC and the 1st trip freeze frame data will be stored in ECM.</p> | <p>*6: 1st trip DTC will be cleared after vehicle is driven once (pattern B) without the same malfunction.</p>                      | EC |
| <p>*7: When the same malfunction is detected in the 2nd trip, the 1st trip freeze frame data will be cleared.</p>   |  |   | C  |

Explanation for Driving Patterns Except for “Misfire <Exhaust Quality Deterioration>”, “Fuel Injection System”

**Driving Pattern A**

Refer to [EC-63, "DIAGNOSIS DESCRIPTION : Driving Pattern"](#).

**Driving Pattern B**

Refer to [EC-63, "DIAGNOSIS DESCRIPTION : Driving Pattern"](#).

**DIAGNOSIS DESCRIPTION : Driving Pattern**

INFOID:000000011277880

**CAUTION:**

**Always drive at a safe speed.**

**DRIVING PATTERN A**

Driving pattern A means a trip satisfying the following conditions.

- Engine speed reaches 400 rpm or more.
- Engine coolant temperature rises by 20°C (36°F) or more after starting the engine.
- Engine coolant temperature reaches 70°C (158°F) or more.
- The ignition switch is turned from ON to OFF.

**NOTE:**

- When the same malfunction is detected regardless of driving conditions, reset the counter of driving pattern A.
- When the above conditions are satisfied without detecting the same malfunction, reset the counter of driving pattern A.

**DRIVING PATTERN B**

Driving pattern B means a trip satisfying the following conditions.

- Engine speed reaches 400 rpm or more.
- Engine coolant temperature reaches 70°C (158°F) or more.
- Vehicle speed of 70 – 120 km/h (44 – 75 MPH) is maintained for 60 seconds or more under the control of closed loop.
- Vehicle speed of 30 – 60 km/h (19 – 37 MPH) is maintained for 10 seconds or more under the control of closed loop.
- Under the closed loop control condition, the following state reaches 12 seconds or more in total: Vehicle speed of 4 km/h (2 MPH) or less with idling condition.
- The state of driving at 10 km/h (7 MPH) or more reaches 10 minutes or more in total.
- A lapse of 22 minutes or more after engine start.

**NOTE:**

- Drive the vehicle at a constant velocity.
- When the same malfunction is detected regardless of driving conditions, reset the counter of driving pattern B.
- When the above conditions are satisfied without detecting the same malfunction, reset the counter of driving pattern B.

**DRIVING PATTERN C**

Driving pattern C means operating vehicle as per the following:

The following conditions should be satisfied at the same time:

Engine speed: (Engine speed in the freeze frame data) ±375 rpm

## DIAGNOSIS SYSTEM (ECM)

[QR25DE]

### < SYSTEM DESCRIPTION >

Calculated load value: (Calculated load value in the freeze frame data) x (1±0.1) [%]

Engine coolant temperature condition:

- When the freeze frame data shows lower than 70°C (158°F), engine coolant temperature should be lower than 70°C (158°F).
- When the freeze frame data shows higher than or equal to 70°C (158°F), engine coolant temperature should be higher than or equal to 70°C (158°F).

#### **NOTE:**

- When the same malfunction is detected regardless of the above vehicle conditions, reset the counter of driving pattern C.
- When the above conditions are satisfied without detecting the same malfunction, reset the counter of driving pattern C.
- The 1st trip DTC will be cleared when C counter is counted once without the same malfunction after DTC is stored in ECM.

### DRIVING PATTERN D

Driving pattern D means a trip satisfying the following conditions.

- The state of driving at 40 km/h (25 MPH) reaches 300 seconds or more in total.
- Idle speed lasts 30 seconds or more.
- A lapse of 600 seconds or more after engine start.

#### **NOTE:**

- When the same malfunction is detected regardless of driving conditions, reset the counter of driving pattern D.
- When the above conditions are satisfied without detecting the same malfunction, reset the counter of driving pattern D.

### DIAGNOSIS DESCRIPTION : System Readiness Test (SRT) Code

INFOID:000000011277881

System Readiness Test (SRT) code is specified in Service \$01 of SAE J1979/ISO 15031-5.

As part of an enhanced emissions test for Inspection & Maintenance (I/M), certain states require the status of SRT be used to indicate whether the ECM has completed self-diagnosis of major emission systems and components. Completion must be verified in order for the emissions inspection to proceed.

If a vehicle is rejected for a State emissions inspection due to one or more SRT items indicating "INCMP", use the information in this Service Manual to set the SRT to "CMPLT".

In most cases the ECM will automatically complete its self-diagnosis cycle during normal usage, and the SRT status will indicate "CMPLT" for each application system. Once set as "CMPLT", the SRT status remains "CMPLT" until the self-diagnosis memory is erased.

Occasionally, certain portions of the self-diagnostic test may not be completed as a result of the customer's normal driving pattern; the SRT will indicate "INCMP" for these items.

#### **NOTE:**

The SRT will also indicate "INCMP" if the self-diagnosis memory is erased for any reason or if the ECM memory power supply is interrupted for several hours.

If, during the state emissions inspection, the SRT indicates "CMPLT" for all test items, the inspector will continue with the emissions test. However, if the SRT indicates "INCMP" for one or more of the SRT items the vehicle is returned to the customer untested.

#### **NOTE:**

If permanent DTC is stored or MIL illuminates during the state emissions inspection, the vehicle is also returned to the customer untested even though the SRT indicates "CMPLT" for all test items. therefore, it is important to check SRT ("CMPLT"), DTC (No DTCs) and permanent DTC (No permanent DTC) before the inspection.

### SRT SET TIMING

SRT is set as "CMPLT" after self-diagnosis has been performed one or more times. Completion of SRT is done regardless of whether the result is OK or NG. The set timing is different between OK and NG results and is shown in the table below.



# DIAGNOSIS SYSTEM (ECM)

< SYSTEM DESCRIPTION >

[QR25DE]

Self-diagnosis result		Example						
		Diagnosis	Ignition cycle					
			← ON →	OFF	← ON →	OFF	← ON →	OFF
All OK	Case 1	P0400	OK (1)	— (1)	OK (2)	— (2)		
		P0402	OK (1)	— (1)	— (1)	OK (2)		
		P1402	OK (1)	OK (2)	— (2)	— (2)		
		SRT of EGR	“CMPLT”	“CMPLT”	“CMPLT”	“CMPLT”		
	Case 2	P0400	OK (1)	— (1)	— (1)	— (1)		
		P0402	— (0)	— (0)	OK (1)	— (1)		
		P1402	OK (1)	OK (2)	— (2)	— (2)		
		SRT of EGR	“INCMP”	“INCMP”	“CMPLT”	“CMPLT”		
NG exists	Case 3	P0400	OK	OK	—	—		
		P0402	—	—	—	—		
		P1402	NG	—	NG	NG (Consecutive NG)		
		(1st trip) DTC	1st trip DTC	—	1st trip DTC	DTC (= MIL ON)		
		SRT of EGR	“INCMP”	“INCMP”	“INCMP”	“CMPLT”		

OK: Self-diagnosis is carried out and the result is OK.

NG: Self-diagnosis is carried out and the result is NG.

—: Self-diagnosis is not carried out.

When all SRT related self-diagnoses show OK results in a single cycle (Ignition OFF-ON-OFF), the SRT will indicate “CMPLT”. → Case 1 above

When all SRT related self-diagnoses show OK results through several different cycles, the SRT will indicate “CMPLT” at the time the respective self-diagnoses have at least one OK result. → Case 2 above

If one or more SRT related self-diagnoses show NG results in 2 consecutive cycles, the SRT will also indicate “CMPLT”. → Case 3 above

The table above shows that the minimum number of cycles for setting SRT as “INCMP” is the number one (1) for each self-diagnosis (Case 1 & 2) or the number two (2) for one of self-diagnoses (Case 3). However, in preparation for the state emissions inspection, it is unnecessary for each self-diagnosis to be executed twice (Case 3) for the following reasons:

- The SRT will indicate “CMPLT” at the time the respective self-diagnoses have one (1) OK result.
- The emissions inspection requires “CMPLT” of the SRT only with OK self-diagnosis results.
- During SRT driving pattern, the 1st trip DTC (NG) is detected prior to “CMPLT” of SRT and the self-diagnosis memory must be erased from the ECM after repair.
- If the 1st trip DTC is erased, all the SRT will indicate “INCMP”.

**NOTE:**

SRT can be set as “CMPLT” together with the DTC(s). Therefore, DTC check must always be carried out prior to the state emission inspection even though the SRT indicates “CMPLT”.

## DIAGNOSIS DESCRIPTION : Permanent Diagnostic Trouble Code (Permanent DTC)

INFOID:000000011277882

Permanent DTC is defined in SAE J1979/ISO 15031-5 Service \$0A.

ECM stores a DTC issuing a command of turning on MIL as a permanent DTC and keeps storing the DTC as a permanent DTC until ECM judges that there is no presence of malfunction.

Permanent DTCs cannot be erased by using the erase function of CONSULT or Generic Scan Tool (GST) and by disconnecting the battery to shut off power to ECM. This prevents a vehicle from passing the in-use inspection without repairing a malfunctioning part.

When not passing the in-use inspection due to more than one permanent DTC, permanent DTCs should be erased, referring to this manual.

**NOTE:**

- The important items in in-use inspection are that MIL is not ON, SRT test items are set, and permanent DTCs are not included.
- Permanent DTCs do not apply for regions that permanent DTCs are not regulated by law.

< SYSTEM DESCRIPTION >

## PERMANENT DTC SET TIMING

The setting timing of permanent DTC is stored in ECM with the lighting of MIL when a DTC is confirmed.

## DIAGNOSIS DESCRIPTION : Malfunction Indicator Lamp (MIL)

INFOID:0000000011277883

When emission-related ECU detects a malfunction in the emission control systems components and/or the powertrain control components (which affect vehicle emissions), it turns on/blinks MIL to inform the driver that a malfunction has been detected.

1. The MIL illuminates when ignition switch is turned ON (engine is not running).

**NOTE:**

Check the MIL circuit if MIL does not illuminate. Refer to [EC-479, "Diagnosis Procedure"](#).

2. When the engine is started, the MIL should go off.

**NOTE:**

If MIL continues to illuminate/blink, perform self-diagnoses and inspect/repair accordingly because an emission-related ECU has detected a malfunction in the emission control systems components and/or the powertrain control components (which affect vehicle emissions).

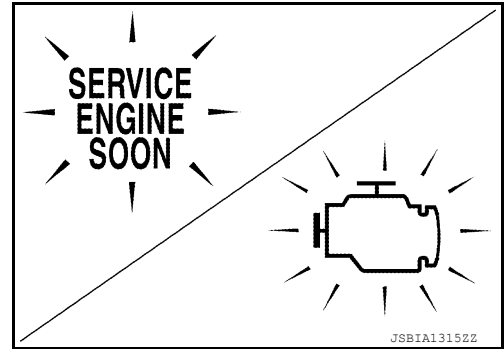

## On Board Diagnosis Function

INFOID:0000000011277884

### ON BOARD DIAGNOSIS ITEM

The on board diagnostic system has the following functions.

Diagnostic test mode	Function
Bulb check	MIL can be checked.
SRT status	ECM can read if SRT codes are set.
Malfunction warning	If ECM detects a malfunction, it illuminates or blinks MIL to inform the driver that a malfunction has been detected.
Self-diagnostic results	DTCs or 1st trip DTCs stored in ECM can be read.
Accelerator pedal released position learning	ECM can learn the accelerator pedal released position. Refer to <a href="#">EC-142, "Work Procedure"</a> .
Throttle valve closed position learning	ECM can learn the throttle valve closed position. Refer to <a href="#">EC-143, "Work Procedure"</a> .
Idle air volume learning	ECM can learn the idle air volume. Refer to <a href="#">EC-144, "Work Procedure"</a> .
Mixture ratio self-learning value clear	Mixture ratio self-learning value can be erased. Refer to <a href="#">EC-146, "Work Procedure"</a> .

## BULB CHECK MODE

### Description

This function allows damage inspection in the MIL bulb (blown, open circuit, etc.).

### Operation Procedure

1. Turn ignition switch ON.
2. The MIL on the instrument panel should stay ON.  
If it remains OFF, check MIL circuit. Refer to [EC-479, "Diagnosis Procedure"](#).

## SRT STATUS MODE

### Description

This function allows to read if ECM has completed the self-diagnoses of major emission control systems and components. For SRT, refer to [EC-64, "DIAGNOSIS DESCRIPTION : System Readiness Test \(SRT\) Code"](#).

### Operation Procedure

1. Turn ignition switch ON and wait 20 seconds.
2. SRT status is indicated as shown below.
  - ECM continues to illuminate MIL if all SRT codes are set.

- ECM blinks MIL for about 10 seconds if all SRT codes are not set.

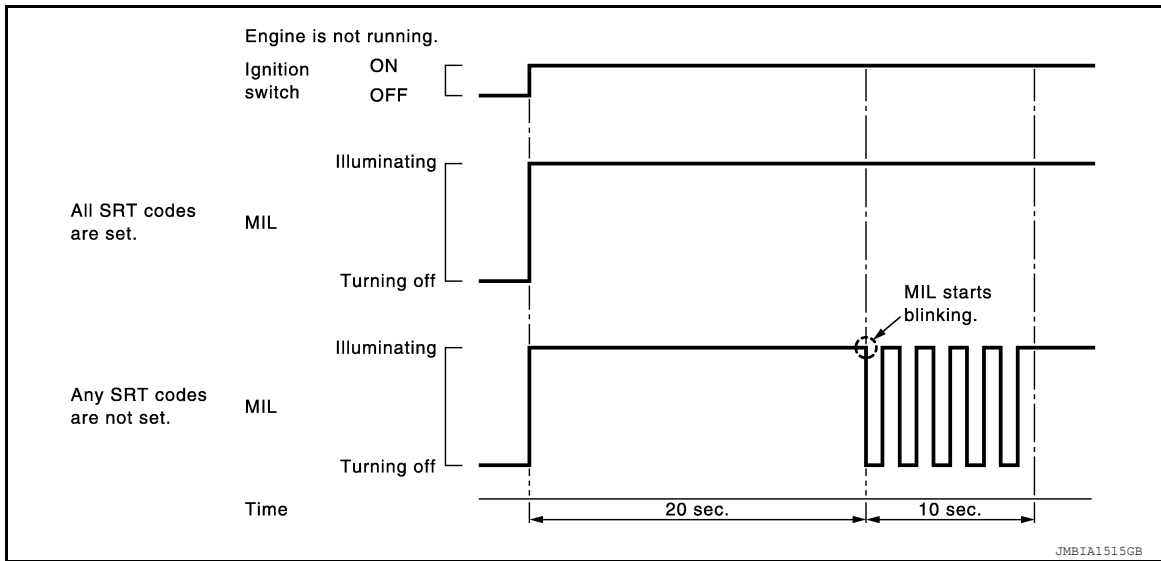

## MALFUNCTION WARNING MODE

### Description

In this function ECM turns on or blinks MIL when it detects a malfunction in the emission control system components and/or the powertrain control components (which affect vehicle emissions) to inform the driver that a malfunction has been detected.

### Operation Procedure

1. Turn ignition switch ON.
2. Check that MIL illuminates.  
If it remains OFF, check MIL circuit. Refer to [EC-479, "Diagnosis Procedure"](#).
3. Start engine and let it idle.
  - For two trip detection logic diagnoses, ECM turns on MIL when it detects the same malfunction twice in the two consecutive driving cycles.
  - For 1st trip detection logic diagnoses, ECM turns on MIL when it detects a malfunction in one driving cycle.
  - ECM blinks MIL when it detects a malfunction that may damage the three way catalyst (misfire).

## SELF-DIAGNOSTIC RESULTS MODE

### Description

This function allows to indicate DTCs or 1st trip DTCs stored in ECM according to the number of times MIL is blinking.

### How to Set Self-diagnostic Results Mode

#### NOTE:

- It is better to count the time accurately with a clock.
  - It is impossible to switch the diagnostic mode when an accelerator pedal position sensor circuit has a malfunction.
  - After ignition switch is turned off, ECM is always released from the "self-diagnostic results" mode.
1. Confirm that accelerator pedal is fully released, turn ignition switch ON and wait 3 seconds.
  2. Repeat the following procedure quickly five times within 5 seconds.
    - Fully depress the accelerator pedal.
    - Fully release the accelerator pedal.
  3. Wait 7 seconds, fully depress the accelerator pedal and keep it depressed for approx. 10 seconds until the MIL starts blinking.

#### NOTE:

Do not release the accelerator pedal for 10 seconds if MIL starts blinking during this period. This blinking is displaying SRT status and is continued for another 10 seconds.

4. Fully release the accelerator pedal.  
ECM has entered to "Self-diagnostic results" mode.

# DIAGNOSIS SYSTEM (ECM)

< SYSTEM DESCRIPTION >

[QR25DE]

**NOTE:**

Wait until the same DTC (or 1st trip DTC) appears to completely confirm all DTCs.

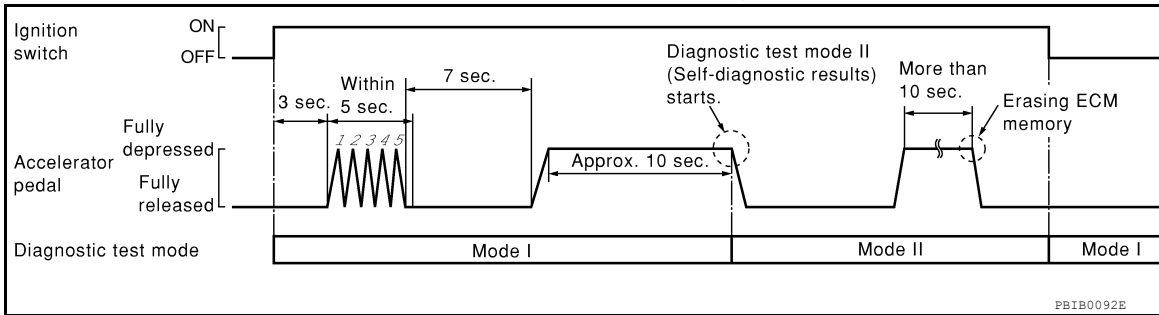

**How to Read Self-diagnostic Results**

The DTC and 1st trip DTC are indicated by the number of blinks of the MIL as shown below.

The DTC and 1st trip DTC are displayed at the same time. If the MIL does not illuminate in diagnostic test mode I (Malfunction warning), all displayed items are 1st trip DTCs. If only one code is displayed when the MIL illuminates in "malfunction warning" mode, it is a DTC; if two or more codes are displayed, they may be either DTCs or 1st trip DTCs. DTC No. is same as that of 1st trip DTC. These unidentified codes can be identified by using the CONSULT or GST. A DTC will be used as an example for how to read a code.

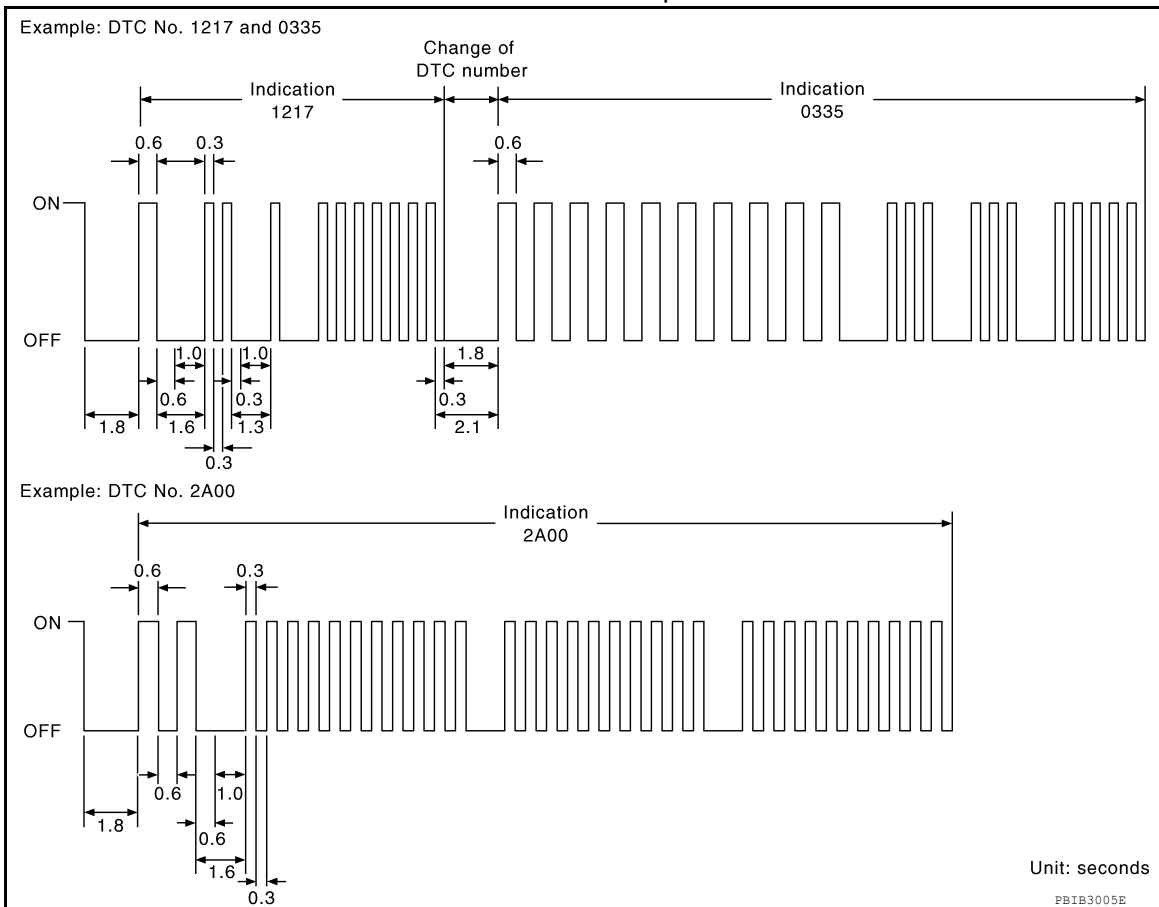

A particular trouble code can be identified by the number of four-digit numeral flashes per the following.

Number	0	1	2	3	4	5	6	7	8	9	A	B	C	D	E	F
Flashes	10	1	2	3	4	5	6	7	8	9	11	12	13	14	15	16

The length of time the 1,000th-digit numeral flashes on and off is 1.2 seconds consisting of an ON (0.6-seconds) - OFF (0.6-seconds) cycle.

The 100th-digit numeral and lower digit numerals consist of a 0.3-seconds ON and 0.3-seconds OFF cycle.

A change from one digit numeral to another occurs at an interval of 1.0-second OFF. In other words, the later numeral appears on the display 1.3 seconds after the former numeral has disappeared.

A change from one trouble code to another occurs at an interval of 1.8-seconds OFF.

# DIAGNOSIS SYSTEM (ECM)

[QR25DE]

## < SYSTEM DESCRIPTION >

In this way, all the detected malfunctions are classified by their DTC numbers. The DTC 0000 refers to no malfunction. Refer to [EC-96, "DTC Index"](#).

### How to Erase Self-diagnostic Results

By performing this procedure, ECM memory is erased and the following diagnostic information is erased as well.

- Diagnostic trouble codes
- 1st trip diagnostic trouble codes
- Freeze frame data
- 1st trip freeze frame data
- System readiness test (SRT) codes
- Test values

#### NOTE:

Also, if a battery terminal is disconnected, ECM memory is erased and the diagnostic information as listed above is erased. (The amount of time required for erasing may vary from a few seconds to several hours.)

1. Turn ignition switch OFF and wait at least 10 seconds.
2. Turn ignition switch ON.
3. Turn ignition switch OFF and wait at least 10 seconds.
4. Turn ignition switch ON.
5. Set ECM in "self-diagnostic results" mode.
6. The diagnostic information has been erased from the backup memory in the ECM. Fully depress the accelerator pedal and keep it depressed for more than 10 seconds.
7. Fully release the accelerator pedal, and confirm the DTC 0000 is displayed.

## CONSULT Function

INFOID:0000000011277885

### FUNCTION

Diagnostic test mode	Function
Self Diagnostic Result	Self-diagnostic results such as 1st trip DTC, DTC and 1st trip freeze frame data or freeze frame data can be read and erased quickly.*
Data Monitor	Input/Output data in the ECM can be read.
Work support	This mode enables a technician to adjust some devices faster and more accurately by following the indications on the CONSULT screen.
Active Test	Diagnostic Test Mode in which CONSULT drives some actuators apart from the ECMs and also shifts some parameters in a specified range.
ECU Identification	ECM part number can be read.
DTC Work Support	The status of system monitoring tests and the self-diagnosis status/results can be confirmed.

\*: The following emission-related diagnostic information is cleared when the ECM memory is erased.

- Diagnostic trouble codes
- 1st trip diagnostic trouble codes
- Freeze frame data
- 1st trip freeze frame data
- System readiness test (SRT) codes
- Test values

## SELF DIAGNOSTIC RESULT MODE

### Self Diagnostic Item

Regarding items of DTC and 1st trip DTC, refer to [EC-96, "DTC Index"](#).)

### How to Read DTC and 1st Trip DTC

DTCs and 1st trip DTCs related to the malfunction are displayed in "self-diag results".

- When ECM detects a 1st trip DTC, "1t" is displayed for "TIME".
- When ECM has detected a current DTC, "0" is displayed for "TIME".
- If "TIME" is neither "0" nor "1t", the DTC occurred in the past and ECM shows the number of times the vehicle has been driven since the last detection of the DTC.

# DIAGNOSIS SYSTEM (ECM)

[QR25DE]

## < SYSTEM DESCRIPTION >

### How to Erase DTC and 1st Trip DTC

**NOTE:**

If the ignition switch stays ON after repair work, be sure to turn ignition switch OFF once. Wait at least 10 seconds and then turn it ON (engine stopped) again.

### Freeze Frame Data and 1st Trip Freeze Frame Data

Freeze frame data item*	Description
DIAG TROUBLE CODE [PXXXX]	<ul style="list-style-type: none"> <li>The engine control component part/control system has a trouble code that is displayed as PXXXX. (Refer to <a href="#">EC-96, "DTC Index"</a>.)</li> </ul>
FUEL SYS-B1	<ul style="list-style-type: none"> <li>"Fuel injection system status" at the moment a malfunction is detected is displayed.</li> <li>- One of the following mode is displayed.</li> <li>- Mode2: Open loop due to detected system malfunction</li> <li>- Mode3: Open loop due to driving conditions (power enrichment, deceleration enrichment)</li> <li>- Mode4: Closed loop - using oxygen sensor(s) as feedback for fuel control</li> <li>- Mode5: Open loop - has not yet satisfied condition to go to closed loop</li> </ul>
CAL/LD VALUE [%]	<ul style="list-style-type: none"> <li>The calculated load value at the moment a malfunction is detected is displayed.</li> </ul>
COOLANT TEMP [°C] or [°F]	<ul style="list-style-type: none"> <li>The engine coolant temperature at the moment a malfunction is detected is displayed.</li> </ul>
L-FUEL TRM-B1 [%]	<ul style="list-style-type: none"> <li>"Long-term fuel trim" at the moment a malfunction is detected is displayed.</li> <li>The long-term fuel trim indicates much more gradual feedback compensation to the base fuel schedule than short-term fuel trim.</li> </ul>
S-FUEL TRM-B1 [%]	<ul style="list-style-type: none"> <li>"Short-term fuel trim" at the moment a malfunction is detected is displayed.</li> <li>The short-term fuel trim indicates dynamic or instantaneous feedback compensation to the base fuel schedule.</li> </ul>
ENGINE SPEED [rpm]	<ul style="list-style-type: none"> <li>The engine speed at the moment a malfunction is detected is displayed.</li> </ul>
VEHICL SPEED [km/h] or [mph]	<ul style="list-style-type: none"> <li>The vehicle speed at the moment a malfunction is detected is displayed.</li> </ul>
ABSOL TH-P/S [%]	<ul style="list-style-type: none"> <li>The throttle valve opening angle at the moment a malfunction is detected is displayed.</li> </ul>
B/FUEL SCHDL [msec]	<ul style="list-style-type: none"> <li>The base fuel schedule at the moment a malfunction is detected is displayed.</li> </ul>
INT/A TEMP SE [°C] or [°F]	<ul style="list-style-type: none"> <li>The intake air temperature at the moment a malfunction is detected is displayed.</li> </ul>
FUEL SYS-B2	<ul style="list-style-type: none"> <li>These items are displayed but are not applicable to this model.</li> </ul>
L-FUEL TRM-B2 [%]	
S-FUEL TRM-B2 [%]	
INT MANI PRES [kPa]	
COMBUST CONDITION	

\*: The items are the same as those of 1st trip freeze frame data.

### DATA MONITOR MODE

**NOTE:**

The following table includes information (items) inapplicable to this vehicle. For information (items) applicable to this vehicle, refer to CONSULT display items.

#### Monitored Item

# DIAGNOSIS SYSTEM (ECM)

< SYSTEM DESCRIPTION >

[QR25DE]

Monitored item	Unit	Monitor Item Selection		Description	Remarks
		ECU INPUT SIGNALS	MAIN SIGNALS		
ENG SPEED	rpm	×	×	<ul style="list-style-type: none"> <li>Indicates the engine speed computed from the signal of the crankshaft position sensor (POS) and camshaft position sensor (PHASE).</li> </ul>	<ul style="list-style-type: none"> <li>Accuracy becomes poor if engine speed drops below the idle rpm.</li> <li>If the signal is interrupted while the engine is running, an abnormal value may be indicated.</li> </ul>
B/FUEL SCHDL	msec	×	×	<ul style="list-style-type: none"> <li>"Base fuel schedule" indicates the fuel injection pulse width programmed into ECM, prior to any learned on board correction.</li> </ul>	<ul style="list-style-type: none"> <li>When engine is running, specification range is indicated in "SPEC".</li> </ul>
A/F ALPHA-B1	%			<ul style="list-style-type: none"> <li>The mean value of the air-fuel ratio feedback correction factor per cycle is indicated.</li> </ul>	<ul style="list-style-type: none"> <li>When the engine is stopped, a certain value is indicated.</li> <li>When engine is running, specification range is indicated in "SPEC".</li> <li>This data also includes the data for the air-fuel ratio learning control.</li> </ul>
COOLAN TEMP/S	°C or °F	×	×	<ul style="list-style-type: none"> <li>The engine coolant temperature (determined by the signal voltage of the engine coolant temperature sensor) is displayed.</li> </ul>	<ul style="list-style-type: none"> <li>When the engine coolant temperature sensor is open or short-circuited, ECM enters fail-safe mode. The engine coolant temperature determined by the ECM is displayed.</li> </ul>
A/F SEN1 (B1)	V	×	×	<ul style="list-style-type: none"> <li>The A/F signal computed from the input signal of the air fuel ratio (A/F) sensor 1 is displayed.</li> </ul>	
HO2S2 (B1)	V	×	×	<ul style="list-style-type: none"> <li>The signal voltage of the heated oxygen sensor 2 is displayed.</li> </ul>	
HO2S2 MNTR(B1)	RICH/LEAN		×	<ul style="list-style-type: none"> <li>Display of heated oxygen sensor 2 signal.</li> <li>- RICH: means the amount of oxygen after three way catalyst is relatively small.</li> <li>- LEAN: means the amount of oxygen after three way catalyst is relatively large.</li> </ul>	<ul style="list-style-type: none"> <li>When the engine is stopped, a certain value is indicated.</li> </ul>
VHCL SPEED SE	km/h or mph	×	×	<ul style="list-style-type: none"> <li>The vehicle speed computed from the vehicle speed signal sent from combination meter is displayed.</li> </ul>	
BATTERY VOLT	V			<ul style="list-style-type: none"> <li>The power supply voltage of ECM is displayed.</li> </ul>	
ACCEL SEN 1	V			<ul style="list-style-type: none"> <li>The accelerator pedal position sensor signal voltage is displayed.</li> </ul>	<ul style="list-style-type: none"> <li>ACCEL SEN 2 signal is converted by ECM internally. Thus, it differs from ECM terminal voltage signal.</li> </ul>
ACCEL SEN 2					
TP SEN 1-B1	V	×	×	<ul style="list-style-type: none"> <li>The throttle position sensor signal voltage is displayed.</li> </ul>	<ul style="list-style-type: none"> <li>TP SEN 2-B1 signal is converted by ECM internally. Thus, it differs from ECM terminal voltage signal.</li> </ul>
TP SEN 2-B1		×	×		
FUEL T/TMP SE	°C or °F			<ul style="list-style-type: none"> <li>The fuel temperature (determined by the signal voltage of the fuel tank temperature sensor) is displayed.</li> </ul>	

A  
EC  
C  
D  
E  
F  
G  
H  
I  
J  
K  
L  
M  
N  
O  
P

# DIAGNOSIS SYSTEM (ECM)

< SYSTEM DESCRIPTION >

[QR25DE]

Monitored item	Unit	Monitor Item Selection		Description	Remarks
		ECU IN-PUT SIGNALS	MAIN SIGNALS		
EVAP SYS PRES	V			<ul style="list-style-type: none"> <li>The signal voltage of EVAP control system pressure sensor is displayed.</li> </ul>	
FUEL LEVEL SE	V	×		<ul style="list-style-type: none"> <li>The signal voltage of the fuel level sensor is displayed.</li> </ul>	
START SIGNAL	On/Off			<ul style="list-style-type: none"> <li>Indicates start signal status [ON/OFF] computed by the ECM according to the signals of engine speed and battery voltage.</li> </ul>	<ul style="list-style-type: none"> <li>After starting the engine, [OFF] is displayed regardless of the starter signal.</li> </ul>
CLSD THL POS	On/Off	×	×	<ul style="list-style-type: none"> <li>Indicates idle position [ON/OFF] computed by ECM according to the accelerator pedal position sensor signal.</li> </ul>	
AIR COND SIG	On/Off	×	×	<ul style="list-style-type: none"> <li>Indicates [ON/OFF] condition of the air conditioner switch as determined by the air conditioner signal.</li> </ul>	
PW/ST SIGNAL	On/Off	×	×	<ul style="list-style-type: none"> <li>[ON/OFF] condition of the power steering system (determined by the signal sent from EPS control unit) is indicated.</li> </ul>	
LOAD SIGNAL	On/Off	×	×	<ul style="list-style-type: none"> <li>Indicates [ON/OFF] condition from the electrical load signal.</li> <li>- On: Rear window defogger switch is ON and/or lighting switch is in 2nd position.</li> <li>- Off: Both rear window defogger switch and lighting switch are OFF.</li> </ul>	
IGNITION SW	On/Off	×	×	<ul style="list-style-type: none"> <li>Indicates [ON/OFF] condition from ignition switch signal.</li> </ul>	
HEATER FAN SW	On/Off	×		<ul style="list-style-type: none"> <li>Indicates [ON/OFF] condition from the heater fan switch signal.</li> </ul>	
BRAKE SW	On/Off			<ul style="list-style-type: none"> <li>Indicates [ON/OFF] condition from the stop lamp switch signal.</li> </ul>	
INJ PULSE-B1	msec			<ul style="list-style-type: none"> <li>Indicates the actual fuel injection pulse width compensated by ECM according to the input signals.</li> </ul>	<ul style="list-style-type: none"> <li>When the engine is stopped, a certain computed value is indicated.</li> </ul>
IGN TIMING	BTDC		×	<ul style="list-style-type: none"> <li>Indicates the ignition timing computed by ECM according to the input signals.</li> </ul>	<ul style="list-style-type: none"> <li>When the engine is stopped, a certain value is indicated.</li> </ul>
CAL/LD VALUE	%			<ul style="list-style-type: none"> <li>"Calculated load value" indicates the value of the current air flow divided by peak air flow.</li> </ul>	
MASS AIRFLOW	g/s			<ul style="list-style-type: none"> <li>Indicates the mass air flow computed by ECM according to the signal voltage of the mass air flow sensor.</li> </ul>	
PURG VOL C/V	%			<ul style="list-style-type: none"> <li>Indicates the EVAP canister purge volume control solenoid valve control value computed by the ECM according to the input signals.</li> <li>The opening becomes larger as the value increases.</li> </ul>	
INT/V TIM(B1)	°CA			<ul style="list-style-type: none"> <li>Indicates [°CA] of intake camshaft advance angle.</li> </ul>	
EXH/V TIM B1	°CA			<ul style="list-style-type: none"> <li>Indicates [°CA] of exhaust camshaft advance angle.</li> </ul>	



# DIAGNOSIS SYSTEM (ECM)

< SYSTEM DESCRIPTION >

[QR25DE]

Monitored item	Unit	Monitor Item Selection		Description	Remarks
		ECU IN-PUT SIGNALS	MAIN SIGNALS		
INT/V SOL(B1)	%			<ul style="list-style-type: none"> <li>The control value of the intake valve timing control solenoid valve (determined by ECM according to the input signals) is indicated.</li> <li>The advance angle becomes larger as the value increases.</li> </ul>	
SWRL CONT S/V	On/Off			<ul style="list-style-type: none"> <li>The control condition of the intake manifold runner control valve (determined by ECM according to the input signals) is indicated.</li> <li>- On: Closed</li> <li>- Off: Open</li> </ul>	
AIR COND RLY	On/Off			<ul style="list-style-type: none"> <li>The air conditioner relay control condition (determined by ECM according to the input signals) is indicated.</li> </ul>	
FUEL PUMP RLY	On/Off			<ul style="list-style-type: none"> <li>Indicates the fuel pump relay control condition determined by ECM according to the input signals.</li> </ul>	
VENT CONT/V	On/Off			<ul style="list-style-type: none"> <li>The control condition of the EVAP canister vent control valve (determined by ECM according to the input signals) is indicated.</li> <li>- On: Closed</li> <li>- Off: Open</li> </ul>	
THRTL RELAY	On/Off			<ul style="list-style-type: none"> <li>Indicates the throttle control motor relay control condition determined by the ECM according to the input signals.</li> </ul>	
FAN DUTY	%			<ul style="list-style-type: none"> <li>Indicates a command value for cooling fan. The value is calculated by ECM based on input signals.</li> </ul>	
HO2S2 HTR (B1)	On/Off			<ul style="list-style-type: none"> <li>Indicates [ON/OFF] condition of heated oxygen sensor 2 heater determined by ECM according to the input signals.</li> </ul>	
I/P PULLY SPD	rpm			<ul style="list-style-type: none"> <li>Indicates the engine speed computed from the input speed sensor signal.</li> </ul>	
VEHICLE SPEED	km/h or mph			<ul style="list-style-type: none"> <li>The vehicle speed computed from the vehicle speed signal sent from TCM is displayed.</li> </ul>	
IDL A/V LEARN	YET/CMPLT			<ul style="list-style-type: none"> <li>Displays the condition of Idle Air Volume Learning</li> <li>- YET: Idle air volume learning has not been performed yet.</li> <li>- CMPLT: Idle air volume learning has already been performed successfully.</li> </ul>	
TRVL AFTER MIL	km or mile			<ul style="list-style-type: none"> <li>Distance traveled while MIL is activated.</li> </ul>	
ENG OIL TEMP	°C or °F			<ul style="list-style-type: none"> <li>The engine oil temperature (determined by the signal voltage of the engine oil temperature sensor) is displayed.</li> </ul>	

A

EC

C

D

E

F

G

H

I

J

K

L

M

N

O

P

# DIAGNOSIS SYSTEM (ECM)

[QR25DE]

< SYSTEM DESCRIPTION >

Monitored item	Unit	Monitor Item Selection		Description	Remarks
		ECU IN-PUT SIGNALS	MAIN SIGNALS		
A/F S1 HTR(B1)	%			<ul style="list-style-type: none"> <li>Air fuel ratio (A/F) sensor 1 heater control value computed by ECM according to the input signals.</li> <li>The current flow to the heater becomes larger as the value increases.</li> </ul>	
VHCL SPEED SE	km/h or mph			<ul style="list-style-type: none"> <li>The vehicle speed computed from the vehicle speed signal sent from combination meter is displayed.</li> </ul>	
SET VHCL SPD	km/h or mph			<ul style="list-style-type: none"> <li>The preset vehicle speed is displayed.</li> </ul>	
MAIN SW	On/Off			<ul style="list-style-type: none"> <li>Indicates [ON/OFF] condition from MAIN switch signal.</li> </ul>	
CANCEL SW	On/Off			<ul style="list-style-type: none"> <li>Indicates [ON/OFF] condition from CANCEL switch signal.</li> </ul>	
RESUME/ACC SW	On/Off			<ul style="list-style-type: none"> <li>Indicates [ON/OFF] condition from RESUME/ACCELERATE switch signal.</li> </ul>	
SET SW	On/Off			<ul style="list-style-type: none"> <li>Indicates [ON/OFF] condition from SET/COAST switch signal.</li> </ul>	
BRAKE SW1	On/Off			<ul style="list-style-type: none"> <li>Indicates [ON/OFF] condition from brake pedal position switch signal.</li> </ul>	
BRAKE SW2	On/Off			<ul style="list-style-type: none"> <li>Indicates [ON/OFF] condition of stop lamp switch signal.</li> </ul>	
VHCL SPD CUT	Non/Cut			<ul style="list-style-type: none"> <li>Indicates the vehicle cruise condition.</li> <li>- Non: Vehicle speed is maintained at the ASCD set speed.</li> <li>- Cut: Vehicle speed decreased to excessively low compared with the ASCD set speed, and ASCD operation is cut off.</li> </ul>	
LO SPEED CUT	Non/Cut			<ul style="list-style-type: none"> <li>Indicates the vehicle cruise condition.</li> <li>- Non: Vehicle speed is maintained at the ASCD set speed.</li> <li>- Cut: Vehicle speed decreased to excessively low, and ASCD operation is cut off.</li> </ul>	
AT OD MONITOR	On/Off			<ul style="list-style-type: none"> <li>Indicates [ON/OFF] condition of CVT O/D according to the input signal from the TCM.</li> </ul>	
AT OD CANCEL	On/Off			<ul style="list-style-type: none"> <li>Indicates [ON/OFF] condition of CVT O/D cancel request signal.</li> </ul>	
CRUISE LAMP	On/Off			<ul style="list-style-type: none"> <li>Indicates [ON/OFF] condition of CRUISE lamp determined by the ECM according to the input signals.</li> </ul>	
SET LAMP	On/Off			<ul style="list-style-type: none"> <li>Indicates [ON/OFF] condition of SET lamp determined by the ECM according to the input signals.</li> </ul>	
A/F ADJ-B1	—			<ul style="list-style-type: none"> <li>Indicates the correction of factor stored in ECM. The factor is calculated from the difference between the target air-fuel ratio stored in ECM and the air-fuel ratio calculated from A/F sensor 1 signal.</li> </ul>	
TUMBLE POS SEN	V			<ul style="list-style-type: none"> <li>The intake manifold runner control valve position sensor signal voltage is displayed.</li> </ul>	

# DIAGNOSIS SYSTEM (ECM)

< SYSTEM DESCRIPTION >

[QR25DE]

Monitored item	Unit	Monitor Item Selection		Description	Remarks
		ECU IN-PUT SIGNALS	MAIN SIGNALS		
P/N POSI SW	On/Off	×	×	<ul style="list-style-type: none"> <li>Indicates [ON/OFF] condition from the park/neutral position (PNP) signal.</li> </ul>	A C
INT/A TEMP SE	°C or °F	×	×	<ul style="list-style-type: none"> <li>The intake air temperature (determined by the signal voltage of the intake air temperature sensor) is indicated.</li> </ul>	D
AC PRESS SEN	V			<ul style="list-style-type: none"> <li>The signal voltage from the refrigerant pressure sensor is displayed.</li> </ul>	E
VTC DTY EX B1	%			<ul style="list-style-type: none"> <li>The control value of the exhaust valve timing control solenoid valve (determined by ECM according to the input signals) is indicated.</li> <li>The advance angle becomes larger as the value increases.</li> </ul>	F
EOP SENSOR	mV			<ul style="list-style-type: none"> <li>The signal voltage of engine oil pressure sensor is displayed.</li> </ul>	G
EVAP LEAK DIAG	YET/CMPLT			<ul style="list-style-type: none"> <li>Indicates the condition of EVAP leak diagnosis.</li> <li>YET: EVAP leak diagnosis has not been performed yet.</li> <li>CMPLT: EVAP leak diagnosis has been performed successfully.</li> </ul>	H
EVAP DIAG READY	ON/OFF			<ul style="list-style-type: none"> <li>Indicates the ready condition of EVAP leak diagnosis.</li> <li>ON: Diagnosis has been ready condition.</li> <li>OFF: Diagnosis has not been ready condition.</li> </ul>	I J
THRTL STK CNT B1*	—			—	K
A/F SEN1 DIAG1(B1)	INCMP/CMPLT			<ul style="list-style-type: none"> <li>Indicates DTC P015A or P015B self-diagnosis condition.</li> <li>- INCMP: Self-diagnosis is incomplete.</li> <li>- CMPLT: Self-diagnosis is complete.</li> </ul>	L
A/F SEN1 DIAG2(B1)	INCMP/CMPLT			<ul style="list-style-type: none"> <li>Indicates DTC P014C or P014D self-diagnosis condition.</li> <li>- INCMP: Self-diagnosis is incomplete.</li> <li>- CMPLT: Self-diagnosis is complete.</li> </ul>	M
A/F SEN1 DIAG3(B1)	ABSNT/PRSNT			<ul style="list-style-type: none"> <li>Indicates DTC P014C, P014D, P015A or P015B self-diagnosis condition.</li> <li>- ABSNT: The vehicle condition is not within the diagnosis range.</li> <li>- PRSNT: The vehicle condition is within the diagnosis range.</li> </ul>	N O
HO2 S2 DIAG1 (B1)	INCMP/CMPLT			<ul style="list-style-type: none"> <li>Indicates DTC P0139 self-diagnosis (delayed response) condition.</li> <li>- INCMP: Self-diagnosis is incomplete.</li> <li>- CMPLT: Self-diagnosis is complete.</li> </ul>	P
HO2 S2 DIAG2 (B1)	INCMP/CMPLT			<ul style="list-style-type: none"> <li>Indicates DTC P0139 self-diagnosis (slow response) condition.</li> <li>- INCMP: Self-diagnosis is incomplete.</li> <li>- CMPLT: Self-diagnosis is complete.</li> </ul>	

EC

# DIAGNOSIS SYSTEM (ECM)

< SYSTEM DESCRIPTION >

[QR25DE]

Monitored item	Unit	Monitor Item Selection		Description	Remarks
		ECU IN-PUT SIGNALS	MAIN SIGNALS		
SYSTEM 1 DIAGNOSIS A B1	INCMP/CM-PLT			<ul style="list-style-type: none"> <li>Indicates DTC P117A self-diagnosis condition.</li> <li>INCMP: Self-diagnosis is incomplete.</li> <li>CMPLT: Self-diagnosis is complete.</li> </ul>	
SYSTEM 1 DIAGNOSIS B B1	ABSNT/PRSNT			<ul style="list-style-type: none"> <li>Indicates DTC P117A self-diagnosis condition.</li> <li>ABSNT: Self-diagnosis standby</li> <li>PRSNT: Under self-diagnosis</li> </ul>	
MASS AIR FLOW SENSOR (Hz)	Hz			<ul style="list-style-type: none"> <li>The signal frequency of the mass air flow sensor is displayed.</li> </ul>	<ul style="list-style-type: none"> <li>When the engine is stopped, a certain value is indicated.</li> <li>When engine is running, specification range is indicated in "SPEC".</li> </ul>

\*: The item is indicated, but not used.

**NOTE:**

Any monitored item that does not match the vehicle being diagnosed is deleted from the display automatically.

## WORK SUPPORT MODE

### Work Item

Work item	Condition	Usage
IDLE AIR VOL LEARN	<ul style="list-style-type: none"> <li>The idle air volume that keeps the engine within the specified range is memorized in ECM.</li> </ul>	When learning the idle air volume
EVAP SYSTEM CLOSE	Close the EVAP canister vent control valve in order to make EVAP system close under the following conditions. <ul style="list-style-type: none"> <li>Ignition switch ON</li> <li>Engine not running</li> <li>Ambient temperature is above 0°C (32°F).</li> <li>No vacuum and no high pressure in EVAP system</li> <li>Fuel tank temp is more than 0°C (32°F).</li> <li>Within 10 minutes after starting "EVAP SYSTEM CLOSE"</li> <li>When trying to execute "EVAP SYSTEM CLOSE" under the condition except above, CONSULT will discontinue it and display appropriate instruction.</li> </ul> <p><b>NOTE:</b> When starting engine, CONSULT may display "BATTERY VOLTAGE IS LOW. CHARGE BATTERY", even in when using a charged battery.</p>	When detecting EVAP vapor leak in the EVAP system
FUEL PRESSURE RELEASE	<ul style="list-style-type: none"> <li>Fuel pump will stop by touching "START" during idling. Crank a few times after engine stalls.</li> </ul>	When releasing fuel pressure from fuel line
TARGET IGN TIM ADJ*	<ul style="list-style-type: none"> <li>Idle condition</li> </ul>	When adjusting target ignition timing
TARGET IDLE RPM ADJ*	<ul style="list-style-type: none"> <li>Idle condition</li> </ul>	When setting target idle speed
VIN REGISTRATION	<ul style="list-style-type: none"> <li>In this mode, VIN is registered in ECM.</li> </ul>	When registering VIN in ECM
SELF-LEARNING CONT	<ul style="list-style-type: none"> <li>The coefficient of self-learning control mixture ratio returns to the original coefficient.</li> </ul>	When clearing mixture ratio self-learning value
CLSD THL POS LEARN	<ul style="list-style-type: none"> <li>Ignition on and engine stopped.</li> </ul>	When learning the throttle valve closed position
SAVING DATA FOR REPLC CPU	In this mode, save data that is in ECM.	SAVING DATA FOR REPLC CPU
WRITING DATA FOR REPLC CPU	In this mode, write data stored by "SAVE DATA FOR CPU REPLC" in work support mode to ECM.	WRITING DATA FOR REPLC CPU

# DIAGNOSIS SYSTEM (ECM)

[QR25DE]

< SYSTEM DESCRIPTION >

\*: This function is not necessary in the usual service procedure.

## ACTIVE TEST MODE

### Test Item

Test item	Condition	Judgment	Check item (Remedy)
FUEL INJECTION	<ul style="list-style-type: none"> <li>Engine: Return to the original trouble condition</li> <li>Change the amount of fuel injection using CONSULT.</li> </ul>	If trouble symptom disappears, see CHECK ITEM.	<ul style="list-style-type: none"> <li>Harness and connectors</li> <li>Fuel injector</li> <li>Air fuel ratio (A/F) sensor 1</li> </ul>
ENG COOLANT TEMP	<ul style="list-style-type: none"> <li>Engine: Return to the original trouble condition</li> <li>Change the engine coolant temperature using CONSULT.</li> </ul>	If trouble symptom disappears, see CHECK ITEM.	<ul style="list-style-type: none"> <li>Harness and connectors</li> <li>Engine coolant temperature sensor</li> <li>Fuel injector</li> </ul>
PURG VOL CONT/V	<ul style="list-style-type: none"> <li>Engine: After warming up, run engine at 1,500 rpm.</li> <li>Change the EVAP canister purge volume control solenoid valve opening percent using CONSULT.</li> </ul>	Engine speed changes according to the opening percent.	<ul style="list-style-type: none"> <li>Harness and connectors</li> <li>Solenoid valve</li> </ul>
FUEL/T TEMP SEN	<ul style="list-style-type: none"> <li>Change the fuel tank temperature using CONSULT.</li> </ul>		
FAN DUTY CONTROL*	<ul style="list-style-type: none"> <li>Ignition switch: ON</li> <li>Change duty ratio using CONSULT.</li> </ul>	Cooling fan speed changes.	<ul style="list-style-type: none"> <li>Harness and connectors</li> <li>Cooling fan motor</li> <li>Cooling fan relay</li> <li>Cooling fan control module</li> <li>IPDM E/R</li> </ul>
FUEL PUMP RELAY	<ul style="list-style-type: none"> <li>Ignition switch: ON (Engine stopped)</li> <li>Turn the fuel pump relay "ON" and "OFF" using CONSULT and listen to operating sound.</li> </ul>	Fuel pump relay makes the operating sound.	<ul style="list-style-type: none"> <li>Harness and connectors</li> <li>Fuel pump relay</li> </ul>
TUMBLE CONTROL VALVE	<ul style="list-style-type: none"> <li>Ignition switch: ON</li> <li>Turn intake manifold runner control valve "ON" and "OFF" using CONSULT and listen to operating sound.</li> </ul>	Intake Manifold Runner control valve motor makes an operating sound.	<ul style="list-style-type: none"> <li>Harness and connectors</li> <li>Intake Manifold Runner control valve motor</li> </ul>
IGNITION TIMING	<ul style="list-style-type: none"> <li>Engine: Return to the original trouble condition</li> <li>Timing light: Set</li> <li>Retard the ignition timing using CONSULT.</li> </ul>	If trouble symptom disappears, see CHECK ITEM.	<ul style="list-style-type: none"> <li>Perform Idle Air Volume Learning.</li> </ul>
POWER BALANCE	<ul style="list-style-type: none"> <li>Engine: After warming up, idle the engine.</li> <li>A/C switch OFF</li> <li>Selector lever: P or N</li> <li>Cut off each fuel injector signal one at a time using CONSULT.</li> </ul>	Engine runs rough or stops.	<ul style="list-style-type: none"> <li>Harness and connectors</li> <li>Compression</li> <li>Fuel injector</li> <li>Power transistor</li> <li>Spark plug</li> <li>Ignition coil</li> </ul>
VENT CONTROL/V	<ul style="list-style-type: none"> <li>Ignition switch: ON (Engine stopped)</li> <li>Turn solenoid valve "ON" and "OFF" using CONSULT and listen to operating sound.</li> </ul>	Solenoid valve makes an operating sound.	<ul style="list-style-type: none"> <li>Harness and connectors</li> <li>Solenoid valve</li> </ul>
INT V/T ASSIGN ANGLE	<ul style="list-style-type: none"> <li>Engine: Return to the original trouble condition</li> <li>Change intake valve timing using CONSULT.</li> </ul>	If trouble symptom disappears, see CHECK ITEM.	<ul style="list-style-type: none"> <li>Harness and connectors</li> <li>Intake valve timing control solenoid valve</li> </ul>
EXH V/T ASSIGN ANGLE	<ul style="list-style-type: none"> <li>Engine: Return to the original trouble condition</li> <li>Change exhaust valve timing using CONSULT.</li> </ul>	If trouble symptom disappears, see CHECK ITEM.	<ul style="list-style-type: none"> <li>Harness and connectors</li> <li>Exhaust valve timing control solenoid valve</li> </ul>

# DIAGNOSIS SYSTEM (ECM)

[QR25DE]

## < SYSTEM DESCRIPTION >

\*: Leaving cooling fan OFF with CONSULT while engine is running may cause the engine to overheat.

## DTC WORK SUPPORT MODE

### Test Item

Test mode	Test item	Corresponding DTC No.	Reference page
A/F SEN1	A/F SEN1(B1) P1276	P0130	<a href="#">EC-229</a>
	A/F SENSOR1(B1) P014C/P014D	P014C, P014D	<a href="#">EC-258</a>
	A/F SENSOR1(B1) P015A/P015B	P015A, P015B	<a href="#">EC-258</a>
EVAPORATIVE SYSTEM	PURG FLOW P0441	P0441	<a href="#">EC-309</a>
	PURG VOL CN/V P1444	P0443	<a href="#">EC-314</a>
HO2S2	HO2S2(B1) P1146	P0138	<a href="#">EC-245</a>
	HO2S2(B1) P1147	P0137	<a href="#">EC-239</a>
	HO2S2(B1) P0139	P0139	<a href="#">EC-252</a>

## SRT & P-DTC MODE

### SRT STATUS Mode

- For items whose SRT codes are set, “CMPLT” is displayed on the CONSULT screen; for items whose SRT codes are not set, “INCMP” is displayed.
- “SRT STATUS” provides the presence or absence of permanent DTCs stored in ECM memory.

### PERMANENT DTC STATUS Mode

#### How to display permanent DTC status

1. Turn ignition switch OFF and wait at least 10 seconds.
2. Turn ignition switch ON.
3. Turn ignition switch OFF and wait at least 10 seconds.
4. Turn ignition switch ON.
5. Select “PERMANENT DTC STATUS” in “DTC & SRT CONFIRMATION” mode with CONSULT.

#### NOTE:

Permanent DTCs stored in ECM memory are displayed on the CONSULT screen to show if a driving pattern required for erasing permanent DTCs is complete (CMPLT) or incomplete (INCMP).

#### CAUTION:

Since the “PERMANENT DTC STATUS” screen displays the previous trip information, repeat the following twice to update the information: “Ignition switch OFF”, “Wait for more than 10 seconds” and “Ignition switch ON”.

PERMANENT DTC & SRT CONFIRMATION : PERMANENT DTC STATUS		
<p>CAUTION: Turn ignition switch from ON to OFF twice to update the information on the status screen.</p>		
PERMANENT DTC	DRIVING PATTERN B	DRIVING PATTERN D
XXXX	INCMP	INCMP
XXXX	CMPLT	INCMP
XXXX	INCMP	CMPLT
XXXX	CMPLT	INCMP
XXXX	INCMP	INCMP
XXXX	INCMP	INCMP
<p>The previous trip information is displayed. </p>		

JSBIA0062GB

#### NOTE:

This mode is not used in regions that permanent DTCs are not regulated by law.

### SRT WORK SUPPORT Mode

This mode enables a technician to drive a vehicle to set the SRT while monitoring the SRT status.

# DIAGNOSIS SYSTEM (ECM)

[QR25DE]

< SYSTEM DESCRIPTION >

## PERMANENT DTC WORK SUPPORT Mode

This mode enables a technician to drive a vehicle to complete the driving pattern that is required for erasing permanent DTC.

### NOTE:

This mode is not used in regions that permanent DTCs are not regulated by law.

A

EC

C

D

E

F

G

H

I

J

K

L

M

N

O

P

# ECU DIAGNOSIS INFORMATION

## ECM

### Reference Value

INFOID:000000011277886

#### VALUES ON THE DIAGNOSIS TOOL

##### NOTE:

The following table includes information (items) inapplicable to this vehicle. For information (items) applicable to this vehicle, refer to CONSULT display items.

● Numerical values in the following table are reference values.

● These values are input/output values that ECM receives/transmits and may differ from actual operations.

Example:

The ignition timing shown by the timing light may differ from the ignition timing displayed on the data monitor. This occurs because the timing light shows a value calculated by ECM according to signals received from the cam shaft position sensor and other sensors related to ignition timing.

Monitor Item	Condition		Values/Status
ENG SPEED	• Run engine and compare CONSULT value with the tachometer indication.		Almost the same speed as the tachometer indication.
B/FUEL SCHDL	See <a href="#">EC-161, "Diagnosis Procedure"</a> .		
A/F ALPHA-B1	See <a href="#">EC-161, "Diagnosis Procedure"</a> .		
COOLAN TEMP/S	• Engine: After warming up		More than 70°C (158°F)
A/F SEN1 (B1)	• Engine: After warming up	Maintaining engine speed at 2,000 rpm	Fluctuates around 2.2 V
HO2S2 (B1)	<ul style="list-style-type: none"> <li>• Revving engine from idle up to 3,000 rpm quickly after the following conditions are met.</li> <li>- Engine: After warming up</li> <li>- After keeping engine speed between 3,500 and 4,000 rpm for 1 minute and at idle for 1 minute under no load</li> </ul>		0 - 0.3 V ↔ Approx. 0.6 - 1.0 V
HO2S2 MNTR(B1)	<ul style="list-style-type: none"> <li>• Revving engine from idle up to 3,000 rpm quickly after the following conditions are met.</li> <li>- Engine: After warming up</li> <li>- After keeping engine speed between 3,500 and 4,000 rpm for 1 minute and at idle for 1 minute under no load</li> </ul>		LEAN ↔ RICH
VHCL SPEED SE	• Turn drive wheels and compare CONSULT value with the speedometer indication.		Almost the same speed as speedometer indication
BATTERY VOLT	• Ignition switch: ON (Engine stopped)		11 - 14 V
ACCEL SEN 1	• Ignition switch: ON (Engine stopped)	Accelerator pedal: Fully released	0.5 - 1.0 V
		Accelerator pedal: Fully depressed	4.2 - 4.8 V
ACCEL SEN 2*	• Ignition switch: ON (Engine stopped)	Accelerator pedal: Fully released	0.5 - 1.0 V
		Accelerator pedal: Fully depressed	4.2 - 4.8 V
TP SEN 1-B1	• Ignition switch: ON (Engine stopped) • Selector lever: D	Accelerator pedal: Fully released	More than 0.36 V
		Accelerator pedal: Fully depressed	Less than 4.75 V
TP SEN 2-B1*	• Ignition switch: ON (Engine stopped) • Selector lever: D	Accelerator pedal: Fully released	Less than 4.75 V
		Accelerator pedal: Fully depressed	More than 0.36 V
FUEL T/TMP SE	• Ignition switch: ON		Indicates fuel tank temperature
EVAP SYS PRES	• Ignition switch: ON		Approx. 1.8 - 4.8 V
FUEL LEVEL SE	• Ignition switch: ON		Depending on fuel level of fuel tank
START SIGNAL	• Ignition switch: ON → START → ON		Off → On → Off



# ECM

## < ECU DIAGNOSIS INFORMATION >

[QR25DE]

Monitor Item	Condition	Values/Status	
CLSD THL POS	• Ignition switch: ON (Engine stopped)	Accelerator pedal: Fully released	On
		Accelerator pedal: Slightly depressed	Off
AIR COND SIG	• Engine: After warming up, idle the engine	Air conditioner switch: OFF	Off
		Air conditioner switch: ON (Compressor operates.)	On
PW/ST SIGNAL	• Engine: After warming up, idle the engine	Steering wheel: Not being turned	Off
		Steering wheel: Being turned	On
LOAD SIGNAL	• Ignition switch: ON	Rear window defogger switch: ON and/or Lighting switch: 2nd position	On
		Rear window defogger switch and lighting switch: OFF	Off
IGNITION SW	• Ignition switch: ON → OFF → ON		On → Off → On
HEATER FAN SW	• Engine: After warming up, idle the engine	Heater fan switch: ON	On
		Heater fan switch: OFF	Off
BRAKE SW	• Ignition switch: ON	Brake pedal: Fully released	Off
		Brake pedal: Slightly depressed	On
INJ PULSE-B1	• Engine: After warming up • Selector lever: P or N • Air conditioner switch: OFF • No load	Idle	2.0 - 3.0 msec
		2,000 rpm	1.9 - 2.9 msec
IGN TIMING	• Engine: After warming up • Selector lever: P or N • Air conditioner switch: OFF • No load	Idle	5° - 15° BTDC
		2,000 rpm	25° - 45° BTDC
CAL/LD VALUE	• Engine: After warming up • Selector lever: P or N • Air conditioner switch: OFF • No load	Idle	10% - 35%
		2,500 rpm	10% - 35%
MASS AIRFLOW	• Engine: After warming up • Selector lever: P or N • Air conditioner switch: OFF • No load	Idle	1.0 - 4.0 g/s
		2,500 rpm	4.0 - 10.0 g/s
PURG VOL C/V	• Engine: After warming up • Selector lever: P or N • Air conditioner switch: OFF • No load	Idle (Accelerator pedal: Not depressed even slightly, after engine starting.)	0%
		2,000 rpm	20% - 90%
INT/V TIM(B1)	• Engine: After warming up • Selector lever: P or N • Air conditioner switch: OFF • No load	Idle	-5° - 5°CA
		4,000 rpm	Approx. 0° - 30°CA
EXH/V TIM B1	• Engine: After warming up • Selector lever: P or N • Air conditioner switch: OFF • No load	Idle	-5° - 5°CA
		2,000 rpm	Approx. 0° - 40°CA
INT/V SOL (B1)	• Engine: Idle speed • Selector lever: P or N • Air conditioner switch: OFF • No load	After warming up	0%
		Cold condition [Engine coolant tempera- ture below 60°C (140°F)]	Approx. 50% - 100%
SWRL CONT S/V	• Ignition switch: ON • Engine coolant temperature: Be- tween -7°C (19°F) and 60°C (140°F)	Accelerator pedal: Fully released	On
		Accelerator pedal: Fully depressed	Off

# ECM

## < ECU DIAGNOSIS INFORMATION >

[QR25DE]

Monitor Item	Condition		Values/Status
AIR COND RLY	• Engine: After warming up, idle the engine	Air conditioner switch: OFF	Off
		Air conditioner switch: ON (Compressor operates)	On
FUEL PUMP RLY	• For 1 second after turning ignition switch: ON • Engine running or cranking		On
	• Except above		Off
VENT CONT/V	• Ignition switch: ON		Off
THRTL RELAY	• Ignition switch: ON		On
FAN DUTY	• Engine: Running		0 - 100%
HO2S2 HTR (B1)	• Engine speed: Below 3,600 rpm after the following conditions are met. - Engine: After warming up - Keeping the engine speed between 3,500 and 4,000 rpm for 1 minute and at idle for 1 minute under no load		On
	• Engine speed: Above 3,600 rpm		Off
I/P PULLY SPD	• Vehicle speed: More than 20 km/h (12 MPH)		Almost the same speed as the tachometer indication
VEHICLE SPEED	• Turn drive wheels and compare CONSULT value with the speedometer indication.		Almost the same speed as the speedometer indication
IDL A/V LEARN	• Engine: running	Idle air volume learning has not been performed yet.	YET
		Idle air volume learning has already been performed successfully.	CMPLT
TRVL AFTER MIL	• Ignition switch: ON	Vehicle has traveled after MIL has turned ON.	0 - 65,535 km (0 - 40,723 miles)
ENG OIL TEMP	• Engine: After warming up		More than 70°C (158°F)
A/F S1 HTR(B1)	• Engine: After warming up, idle the engine (More than 140 seconds after starting engine.)		4 - 100%
VHCL SPEED SE	• Turn drive wheels and compare CONSULT value with the speedometer indication.		Almost the same speed as the speedometer indication
SET VHCL SPD	• Engine: Running	ASCD: Operating	The preset vehicle speed is displayed
MAIN SW	• Ignition switch: ON	MAIN switch: Pressed	On
		MAIN switch: Released	Off
CANCEL SW	• Ignition switch: ON	CANCEL switch: Pressed	On
		CANCEL switch: Released	Off
RESUME/ACC SW	• Ignition switch: ON	RESUME/ACCELERATE switch: Pressed	On
		RESUME/ACCELERATE switch: Released	Off
SET SW	• Ignition switch: ON	SET/COAST switch: Pressed	On
		SET/COAST switch: Released	Off
BRAKE SW1 (Brake pedal position switch)	• Ignition switch: ON	Brake pedal: Fully released	On
		Brake pedal: Slightly depressed	Off
BRAKE SW2 (Stop lamp switch)	• Ignition switch: ON	Brake pedal: Fully released	Off
		Brake pedal: Slightly depressed	On
VHCL SPD CUT	• Ignition switch: ON		Non
LO SPEED CUT	• Ignition switch: ON		Non
AT OD MONITOR	• Ignition switch: ON		Off
AT OD CANCEL	• Ignition switch: ON		Off

# ECM

## < ECU DIAGNOSIS INFORMATION >

[QR25DE]

Monitor Item	Condition		Values/Status
CRUISE LAMP	• Ignition switch: ON	MAIN switch: Pressed at the 1st time → at the 2nd time	On → Off
SET LAMP	• MAIN switch: ON • When vehicle speed: Between 40 km/h (25 MPH) and 144 km/h (89 MPH)	ASCD: Operating	On
		ASCD: Not operating	Off
A/F ADJ-B1	• Engine: running		-0.330 - 0.330
TUMBLE POS SEN	• Ignition switch: ON • Engine coolant temperature: Between -7°C (19°F) and 60°C (140°F)	Accelerator pedal: Fully released	Less than 1.4 V
		Accelerator pedal: Fully depressed	More than 2.8 V
P/N POSI SW	• Ignition switch: ON	Selector lever: P or N	On
		Selector lever: Except above	Off
INT/A TEMP SE	• Ignition switch: ON		Indicates intake air temperature
AC PRESS SEN	• Engine speed: Idle • Both A/C switch and blower fan switch: ON (Compressor operates)		1.0 - 4.0 V
VTC DTY EX B1	• Engine: After warming up • Selector lever: P or N • Air conditioner switch: OFF • No load	Idle	0 - 2%
		2,000 rpm	Approx. 0- 90%
EOP SENSOR	• Engine: After warming up • Selector lever: P or N • Air conditioner switch: OFF • No load	Idle	1,000 - 2,000 mV
		2,000 rpm	1,500 - 3,500 mV
EVAP LEAK DIAG	• Ignition switch: ON		Indicates the condition of EVAP leak diagnosis.
EVAP DIAG READY	• Ignition switch: ON		Indicates the ready condition of EVAP leak diagnosis.
THRTL STK CNT B1	<b>NOTE:</b> The item is indicated, but not used.		—
A/F SEN1 DIAG1 (B1)	DTC P015A and P015B self-diagnosis is incomplete.		INCMP
	DTC P015A and P015B self-diagnosis is complete.		CMPLT
A/F SEN1 DIAG2 (B1)	DTC P014C and P014D self-diagnosis is incomplete.		INCMP
	DTC P014C and P014D self-diagnosis is complete.		CMPLT
A/F SEN1 DIAG3 (B1)	The vehicle condition is not within the diagnosis range of DTC P014C, P014D, P015A or P015B.		ABSNT
	The vehicle condition is within the diagnosis range of DTC P014C, P014D, P015A or P015B.		PRSNT
HO2 S2 DIAG1 (B1)	DTC P0139 self-diagnosis (delayed response) is incomplete.		INCMP
	DTC P0139 self-diagnosis (delayed response) is complete.		CMPLT
HO2 S2 DIAG2 (B1)	DTC P0139 self-diagnosis (slow response) is incomplete.		INCMP
	DTC P0139 self-diagnosis (slow response) is complete.		CMPLT
SYSTEM 1 DIAG-NOSIS A B1	DTC P117A self-diagnosis is incomplete.		INCMP
	DTC P117A self-diagnosis is complete.		CMPLT
SYSTEM 1 DIAG-NOSIS B B1	DTC P117A self-diagnosis is on standby.		ABSENT
	DTC P117A self-diagnosis is under diagnosis.		PRSENT
MASS AIR FLOW SENSOR (Hz)	See <a href="#">EC-161. "Diagnosis Procedure"</a> .		

\*: Accelerator pedal position sensor 2 signal and throttle position sensor 2 signal are converted by ECM internally. Thus, they differ from ECM terminals voltage signal.

TERMINAL LAYOUT

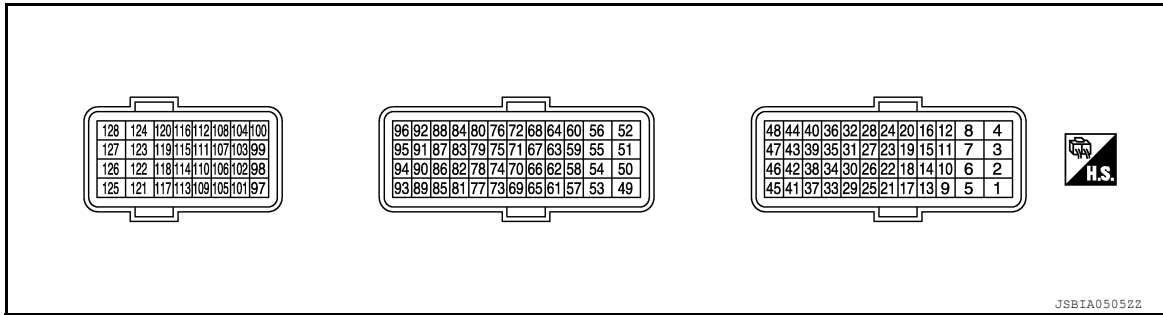

PHYSICAL VALUES

NOTE:

- ECM is located in the engine room left side near battery.
- Specification data are reference values and are measured between each terminal and ground.
- Pulse signal is measured by CONSULT.

Terminal No. (Wire color)		Description		Condition	Value (Approx.)
+	-	Signal name	Input/ Output		
1 (G)	128 (BR)	Throttle control motor (Close)	Output	[Ignition switch: ON] • Engine stopped • Selector lever: D • Accelerator pedal: Fully released	1.8 V★ 5mSec/div  5V/div JMBIA0326GB
2 (GR)	128 (BR)	Throttle control motor power supply	Input	[Ignition switch: ON]	Battery voltage (11 - 14 V)
3 (L)	128 (BR)	Throttle control motor (Open)	Output	[Ignition switch: ON] • Engine stopped • Selector lever: D • Accelerator pedal: Fully depressed	3.2 V★ 1mSec/div  5V/div JMBIA0324GB
4 (W)	8 (—)	Knock sensor	Input	[Engine is running] • Idle speed	2.5 V
8 (—)	—	Sensor ground (Knock sensor shield cir- cuit)	—	—	—

# ECM

## < ECU DIAGNOSIS INFORMATION >

[QR25DE]

Terminal No. (Wire color)		Description	Input/ Output	Condition	Value (Approx.)
+	-	Signal name			
9 (Y) 10 (P) 13 (L) 14 (G)	128 (BR)	Fuel injector No. 4 Fuel injector No. 3 Fuel injector No. 1 Fuel injector No. 2	Output	[Engine is running] • Warm-up condition • Idle speed <b>NOTE:</b> The pulse cycle changes depending on rpm at idle	Battery voltage (11 - 14 V)★ 50mSec/div  10V/div JMBIA0089GB
				[Engine is running] • Warm-up condition • Engine speed: 2,000 rpm	Battery voltage (11 - 14 V)★ 50mSec/div  10V/div JMBIA0090GB
16 (BR)	—	ECM ground	—	—	—
17 (BG)	128 (BR)	EVAP canister purge volume control solenoid valve	Output	[Engine is running] • Idle speed • Accelerator pedal: Not depressed even slightly, after engine starting	Battery voltage (11 - 14 V)★ 50mSec/div  20V/div JMBIA0087GB
				[Engine is running] • Engine speed: About 2,000 rpm (More than 100 seconds after starting engine.)	Battery voltage (11 - 14 V)★ 50mSec/div  10V/div JMBIA0088GB
18 (P)	128 (BR)	Fuel pump relay	Output	[Ignition switch: ON] • For 1 second after turning ignition switch ON	0 - 1.0 V
				[Engine is running]	
				[Ignition switch: ON] • More than 1 second after turning ignition switch ON	Battery voltage (11 - 14 V)
21 (V)	128 (BR)	Throttle control motor relay	Output	[Ignition switch: OFF]	Battery voltage (11 - 14 V)
				[Ignition switch: ON]	0 - 1.0 V

A  
EC  
C  
D  
E  
F  
G  
H  
I  
J  
K  
L  
M  
N  
O  
P

# ECM

## < ECU DIAGNOSIS INFORMATION >

[QR25DE]

Terminal No. (Wire color)		Description	Input/ Output	Condition	Value (Approx.)
+	-	Signal name			
22 (Y)	23 (B)	Heated oxygen sensor 2	Input	[Engine is running] • Revving engine from idle to 3,000 rpm quickly after the following conditions are met - Engine: after warming up - Keeping the engine speed between 3,500 and 4,000 rpm for 1 minute and at idle for 1 minute under no load	0 - 1.0 V
23 (B)	—	Sensor ground (Heated oxygen sensor 2)	—	—	—
25 (P)	26 (BR)	Engine oil temperature sensor	Input	[Engine is running]	0 - 4.8 V Output voltage varies with engine oil temperature.
26 (BR)	—	Sensor ground (Engine oil temperature sensor)	—	—	—
27 (L)	—	Sensor ground (Engine coolant temperature sensor)	—	—	—
28 (G)	27 (L)	Engine coolant temperature sensor	Input	[Engine is running]	0 - 4.8 V Output voltage varies with engine coolant temperature.
30 (R)	—	Sensor ground [Camshaft position sensor (PHASE)]	—	—	—
31 (W)	30 (R)	Camshaft position sensor (PHASE)	Input	[Engine is running] • Warm-up condition • Idle speed <b>NOTE:</b> The pulse cycle changes depending on rpm at idle	<p style="text-align: center;">1.0 - 2.0★ 10mSec/div</p> <p style="text-align: right;">2V/div JPBIA4726Z2</p>
				[Engine is running] • Engine speed is 2,000 rpm	<p style="text-align: center;">1.0 - 2.0★ 10mSec/div</p> <p style="text-align: right;">2V/div JPBIA4727Z2</p>
32 (B)	—	Sensor power supply [Camshaft position sensor (PHASE)]	—	[Ignition switch: ON]	5.0 V
33 (V)	34 (GR)	Intake air temperature sensor	Input	[Engine is running]	0 - 4.8 V Output voltage varies with intake air temperature.
34 (GR)	—	Sensor ground (Mass air flow sensor, intake air temperature sensor)	—	—	—

# ECM

## < ECU DIAGNOSIS INFORMATION >

[QR25DE]

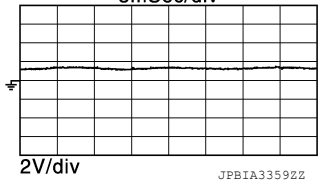
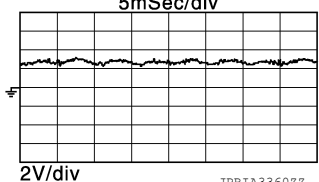
Terminal No. (Wire color)		Description		Condition	Value (Approx.)
+	-	Signal name	Input/ Output		
35 (BR)	34 (GR)	Mass air flow sensor	Input	[Ignition switch: ON] • Engine stopped	1.3 V
				[Engine is running] • Warm-up condition • Idle speed	1.3 - 1.6 V
				[Engine is running] • Warm-up condition • Engine is revving from idle to about 4,000 rpm	1.3 - 1.6 to 2.5 V (Check for linear voltage rise in response to engine being increased to about 4,000 rpm.)
36 (L)	—	Sensor power supply (Mass air flow sensor, intake air temperature sensor)	—	[Ignition switch: ON]	5.0 V
37 (—)	—	Shield	—	—	—
38 (SB)	—	Sensor ground (Engine oil pressure sensor)	—	—	—
39 (P)	38 (SB)	Engine oil pressure sensor	Input	[Engine is running] • Warm-up condition • Idle speed	1.3 V★ 
				[Engine is running] • Warm-up condition • Engine speed is 2,000 rpm	2.7 V★ 
40 (W)	38 (SB)	Sensor power supply (Engine oil pressure sensor)	—	[Ignition switch: ON]	5.0 V
41 (Y)	128 (BR)	A/F sensor 1	Input	[Ignition switch: ON]	2.2 V Output voltage varies with air fuel ratio.
42 (B)	—	Sensor ground [Exhaust valve timing control position sensor]	—	—	—

A  
EC  
C  
D  
E  
F  
G  
H  
I  
J  
K  
L  
M  
N  
O  
P

# ECM

## < ECU DIAGNOSIS INFORMATION >

[QR25DE]

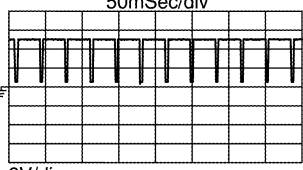
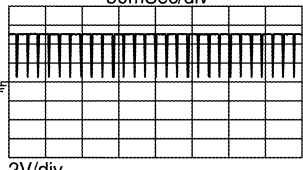
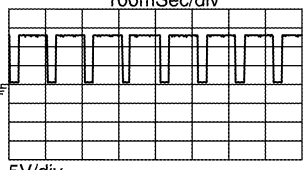
Terminal No. (Wire color)		Description	Input/ Output	Condition	Value (Approx.)
+	-				
43 (LG)	42 (B)	Exhaust valve timing control position sensor	Input	[Engine is running] • Warm-up condition • Idle speed <b>NOTE:</b> The pulse cycle changes depending on rpm at idle	1.0 - 2.0★ 50mSec/div  2V/div
				[Engine is running] • Engine speed is 2,000 rpm	1.0 - 2.0★ 50mSec/div  2V/div
44 (Y)	—	Sensor power supply [Exhaust valve timing control position sensor]	—	[Ignition switch: ON]	5 V
45 (G)	128 (BR)	A/F sensor 1	Input	[Engine is running] • Engine speed is 2,000 rpm	1.8 V
49 (G)	128 (BR)	Intake manifold runner control valve motor (Close)	Output	[Ignition switch ON] • Engine coolant temperature: Between -7°C (19°F) and 60°C (140°F) • Accelerator pedal: Depressed → fully released	Battery voltage appears for about 1 second.
50 (V)	128 (BR)	Intake manifold runner control valve motor power supply	Input	[Ignition switch: ON]	Battery voltage (11 - 14 V)
51 (Y)	128 (BR)	Intake manifold runner control valve motor (Open)	Output	[Ignition switch ON] • Engine coolant temperature: Between -7°C (19°F) and 60°C (140°F) • Accelerator pedal: Fully released → depressed	Battery voltage appears for about 1 second.
52 (B)	—	ECM ground	—	—	—
53 (P)	128 (BR)	A/F sensor 1 heater	Input	[Engine is running] • Warm-up condition • Idle speed (More than 140 seconds after starting engine)	2.9 - 8.8 V★ 100mSec/div  5V/div



# ECM

## < ECU DIAGNOSIS INFORMATION >

[QR25DE]

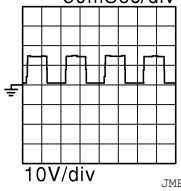
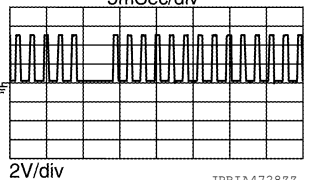
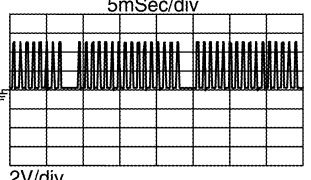
Terminal No. (Wire color)		Description		Condition	Value (Approx.)
+	-	Signal name	Input/ Output		
54 (V)	128 (BR)	Heated oxygen sensor 2 heater	Output	[Engine is running] • Engine speed: Below 3,600 rpm after the following conditions are met - Engine: after warming up - Keeping the engine speed between 3,500 and 4,000 rpm for 1 minute and at idle for 1 minute under no load	<p>10 V★</p> <p>50mSec/div</p>  <p>10V/div</p> <p style="text-align: right; font-size: small;">JMBIA0325GB</p>
				[Ignition switch: ON] • Engine stopped [Engine is running] • Engine speed: Above 3,600 rpm	<p>Battery voltage (11 - 14 V)</p>
56 (GR)	128 (BR)	Intake valve timing intermediate lock control solenoid valve	Output	[Engine is running] • Warm-up condition • Idle speed	<p>0 V</p>
				[Engine is running] • Cold condition [Engine coolant temperature: below 60°C (140°F)] • Idle speed	<p>Battery voltage (11 - 14 V)</p>
70 (BR)	—	Sensor ground [Crankshaft position sensor (POS)]	—	—	—
71 (GR)	70 (BR)	Crankshaft position sensor (POS)	Input	[Engine is running] • Warm-up condition • Idle speed <b>NOTE:</b> The pulse cycle changes depending on rpm at idle	<p>4.0 V★</p> <p>5mSec/div</p>  <p>2V/div</p> <p style="text-align: right; font-size: small;">JPBIA47282Z</p>
				[Engine is running] • Engine speed: 2,000 rpm	<p>4.0 V★</p> <p>5mSec/div</p>  <p>2V/div</p> <p style="text-align: right; font-size: small;">JPBIA47292Z</p>
72 (L)	—	Sensor power supply [Crankshaft position sensor (POS)]	—	[Ignition switch: ON]	<p>5.0 V</p>
73 (—)	—	Shield	—	—	—
77 (W)	78 (B)	Throttle position sensor 2	Input	[Ignition switch: ON] • Engine stopped • Selector lever: D • Accelerator pedal: Fully released	<p>Less than 4.75 V</p>
				[Ignition switch: ON] • Engine stopped • Selector lever: D • Accelerator pedal: Fully depressed	<p>More than 0.36 V</p>
78 (B)	—	Sensor ground (Throttle position sensor 1, 2)	—	—	—

A  
EC  
C  
D  
E  
F  
G  
H  
I  
J  
K  
L  
M  
N  
O  
P

# ECM

## < ECU DIAGNOSIS INFORMATION >

[QR25DE]

Terminal No. (Wire color)		Description	Input/ Output	Condition	Value (Approx.)
+	-	Signal name			
79 (G)	78 (B)	Throttle position sensor 1	Input	[Ignition switch: ON] • Engine stopped • Selector lever: D • Accelerator pedal: Fully released	More than 0.36 V
				[Ignition switch: ON] • Engine stopped • Selector lever: D • Accelerator pedal: Fully depressed	Less than 4.75 V
80 (R)	—	Sensor power supply (Throttle position sensor)	—	[Ignition switch: ON]	5.0 V
81 (R)	128 (BR)	Power supply for ECM (Backup)	Input	[Ignition switch: OFF]	Battery voltage (11 - 14 V)
83 (L)	92 (LG)	Intake manifold runner control valve position sensor	Input	[Ignition switch ON] • Engine coolant temperature: Between -7°C (19°F) and 60°C (140°F) • Accelerator pedal: Fully released	Less than 1.4 V
				[Ignition switch ON] • Engine coolant temperature: Between -7°C (19°F) and 60°C (140°F) • Accelerator pedal: Slightly depressed	More than 2.8 V
84 (V)	—	Sensor power supply (Intake manifold runner control valve position sensor)	—	[Ignition switch: ON]	5.0 V
85 (G)	—	Lin communication line	Input/ Output	—	—
86 (Y)	128 (BR)	Ignition signal No. 1	Output	[Engine is running] • Warm-up condition • Idle speed <b>NOTE:</b> The pulse cycle changes depending on rpm at idle	
87 (BR)		Ignition signal No. 2			
90 (W)		Ignition signal No. 3			
91 (SB)		Ignition signal No. 4			
89 (P)	128 (BR)	ECM relay (Self shut-off)	Output	[Engine is running] [Ignition switch: OFF] • A few seconds after turning ignition switch OFF	0 - 1.0 V
				[Ignition switch: OFF] • More than a few seconds after turning ignition switch OFF	Battery voltage (11 - 14 V)
92 (LG)	—	Sensor ground (Intake manifold runner control valve position sensor)	—	—	—

# ECM

## < ECU DIAGNOSIS INFORMATION >

[QR25DE]

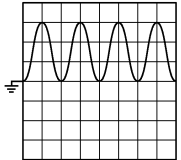
Terminal No. (Wire color)		Description	Input/ Output	Condition	Value (Approx.)
+	-	Signal name			
93 (L)	128 (BR)	Intake valve timing control solenoid valve	Output	[Engine is running] • Warm-up condition • Idle speed	0 V
				[Engine is running] • Warm-up condition • When revving engine up to 2,000rpm Quickly	Battery voltage (11 - 14 V) ★  5V/div <small>JMBIA1638GB</small>
94 (BR)	128 (BR)	Exhaust valve timing control solenoid valve	Output	[Engine is running] • Warm-up condition • Idle speed	0 V
				[Engine is running] • Warm-up condition • Engine speed: 2,000 rpm	Battery voltage (11 - 14 V)
97 (GR)	128 (BR)	EVAP canister vent control valve	Output	[Ignition switch: ON]	Battery voltage (11 - 14 V)
99 (P)	—	CAN communication line (CAN-L)	Input/ Output	—	—
100 (L)	—	CAN communication line (CAN-H)	Input/ Output	—	—
103 (Y)	124 (W)	Refrigerant pressure sensor	Input	[Engine is running] • Warm-up condition • Both A/C switch and blower fan motor switch: ON (Compressor operates)	1.0 - 4.0 V
104 (R)	—	Sensor power supply (Refrigerant pressure sensor)	—	[Ignition switch: ON]	5.0 V
109 (LG)	128 (BR)	Ignition switch	Input	[Ignition switch: OFF]	0 V
				[Ignition switch: ON]	Battery voltage (11 - 14 V)
110 (G)	111 (BR)	ASCDC steering switch	Input	[Ignition switch: ON] • ASCDC steering switch: OFF	4 V
				[Ignition switch: ON] • MAIN switch: Pressed	0 V
				[Ignition switch: ON] • CANCEL switch: Pressed	1 V
				[Ignition switch: ON] • ACCEL/RES switch: Pressed	3 V
				[Ignition switch: ON] • COAST/SET switch: Pressed	2 V
111 (BR)	—	Sensor ground (ASCDC steering switch)	—	—	—
113 (R)	—	Sensor power supply (EVAP control system pressure sensor)	—	[Ignition switch: ON]	5.0 V
114 (BR)	124 (W)	EVAP control system pressure sensor	Input	[Ignition switch: ON]	0.5 - 4.6 V

A

EC

C

D

E

F

G

H

I

J

K

L

M

N

O

P

# ECM

## < ECU DIAGNOSIS INFORMATION >

[QR25DE]

Terminal No. (Wire color)		Description	Input/ Output	Condition	Value (Approx.)
+	-				
115 (V)	128 (BR)	Stop lamp switch	Input	[Ignition switch: OFF] • Brake pedal: Fully released	0 V
				[Ignition switch: OFF] • Brake pedal: Slightly depressed	Battery voltage (11 - 14 V)
116 (GR)	128 (BR)	Brake pedal position switch	Input	[Ignition switch: OFF] • Brake pedal: Fully released	Battery voltage (11 - 14 V)
117 (W)	128 (BR)	PNP signal	Input	[Ignition switch: ON] • Selector lever: P or N	Battery voltage (11 - 14 V)
				[Ignition switch: ON] • Selector lever: Except above	0 V
118 (SB)	—	Sensor power supply (Accelerator pedal position sensor 2)	—	[Ignition switch: ON]	5.0 V
119 (Y)	120 (LG)	Accelerator pedal position sensor 2	Input	[Ignition switch: ON] • Engine stopped • Accelerator pedal: Fully released	0.25 - 0.5 V
				[Ignition switch: ON] • Engine stopped • Accelerator pedal: Fully depressed	2.0 - 2.5 V
120 (LG)	—	Sensor ground (Accelerator pedal position sensor 2)	—	—	—
121 (BR)	128 (BR)	Power supply for ECM	Input	[Ignition switch: ON]	Battery voltage (11 - 14 V)
122 (V)	—	Sensor power supply (Accelerator pedal position sensor 1)	—	[Ignition switch: ON]	5.0 V
123 (BR)	—	ECM ground	—	—	—
124 (W)	—	Sensor ground (EVAP control system pressure sensor, refrigerant pressure sensor)	—	—	—
125 (BG)	128 (BR)	Fuel tank temperature sensor	Input	[Engine is running]	0 - 4.8 V Output voltage varies with fuel tank temperature
126 (GR)	127 (L)	Accelerator pedal position sensor 1	Input	[Ignition switch: ON] • Engine stopped • Accelerator pedal: Fully released	0.5 - 1.0 V
				[Ignition switch: ON] • Engine stopped • Accelerator pedal: Fully depressed	4.2 - 4.8 V
127 (R)	—	Sensor ground (Accelerator pedal position sensor 1)	—	—	—
128 (BR)	—	ECM ground	—	—	—

★: Average voltage for pulse signal (Actual pulse signal can be confirmed by oscilloscope.)

### Fail Safe

INFOID:0000000011277887

### NON DTC RELATED ITEM

Detected items	Engine operating condition in fail-safe mode	Remarks	Reference page
Malfunction indicator lamp circuit	Engine speed will not rise more than 2,500 rpm due to the fuel cut	When there is an open circuit on MIL circuit, the ECM cannot warn the driver by lighting up MIL when there is malfunction on engine control system. Therefore, when electrical controlled throttle and part of ECM related diagnoses are continuously detected as NG for 5 trips, ECM warns the driver that engine control system malfunctions and MIL circuit is open by means of operating fail safe function. The fail safe function also operates when above diagnoses except MIL circuit are detected and demands the driver to repair the malfunction.	<a href="#">EC-479. "Component Function Check"</a>

DTC RELATED ITEM

Description

When a DTC is detected, ECM executes a mode (in the Fail-safe mode) applicable to the DTC. The fail-safe mode has the preset traveling control mode (accelerator angle variation and engine output limit) and device fix mode.

Fail safe mode		Vehicle behavior
Traveling control mode	Accelerator angle variation control	ECM controls the accelerator pedal depression speed to make it slower than actual speed. This causes a drop in accelerating performance and encourages the driver to repair malfunction. <b>NOTE:</b> ECM does not control the accelerator pedal releasing speed.
	Engine output control	ECM reduces the engine output, according to the rise in engine speed. This reduces the vehicle speed to encourage the driver to repair malfunction.
Device fix mode		<ul style="list-style-type: none"> <li>This mode fixes the IVT control solenoid valve and the EVT control solenoid valve in the reference position.</li> <li>The intake manifold runner control valve motor is turned OFF (intake manifold runner control valve opens).</li> </ul>

Fail Safe Pattern

Pattern	Fail safe mode	
A	Traveling control mode	Accelerator angle variation control
B		Engine output control
C	Device fix mode	

Fail Safe List

×:Applicable —: Not applicable

DTC No.	Detected items	Vehicle behavior			
		Pattern			Others
		A	B	C	
P0011	Intake valve timing control	—	—	×	ECM activates the IVT intermediate lock control solenoid valve to bring the cam sprocket into an intermediate lock condition.
P0014 P0078	Exhaust valve timing control	—	—	×	—
P0101 P0102 P0103	Mass air flow sensor circuit	×	×	×	—
P0122 P0123 P0222 P0223 P2135	Throttle position sensor	—	—	—	The ECM controls the electric throttle control actuator in regulating the throttle opening in order for the idle position to be within +10 degrees. The ECM regulates the opening speed of the throttle valve to be slower than the normal condition. So, the acceleration will be poor.

# ECM

## < ECU DIAGNOSIS INFORMATION >

[QR25DE]

DTC No.	Detected items	Vehicle behavior				
		Pattern			Others	
		A	B	C		
P0171 P0172	Fuel injection system	×	—	—	—	
P0197 P0198	Engine oil temperature sensor	—	—	—	Exhaust valve timing control does not function.	
P0300 P0301 P0302 P0303 P0304	Misfire	×	—	—	—	
P0500	Vehicle speed sensor	×	—	—	—	
P050A	Cold start control	—	—	—	—	
P0524	Engine oil pressure	—	—	—	<ul style="list-style-type: none"> <li>• ECM illuminates oil pressure warning lamp on the combination meter.</li> <li>• Engine speed will not rise more than 4,000rpm due to the fuel cut.</li> <li>• Fail-safe is canceled when ignition switch OFF → ON.</li> </ul>	
P052A P052B	Intake valve timing intermediate lock control	—	—	×	—	
P0603	ECM	—	—	—	—	
		—	×	—	ASCD operation may be deactivated.	
P0604	ECM	×	—	×	ASCD operation may be deactivated.	
P0605 P060B	ECM	—	—	—	—	
		×	—	×	ASCD operation may be deactivated.	
P0606	ECM	—	—	—	ASCD operation may be deactivated.	
		×	—	×	ASCD operation may be deactivated.	
P0607	ECM	—	—	—	—	
		—	×	—	—	
P060A	ECM	×	—	×	—	
		×	×	×	ASCD operation may be deactivated.	
P0643	ECM	×	—	×	—	
P1078	Exhaust valve timing control position sensor circuit	×	—	×	—	
P1568	Signal invalid	—	—	—	Active trace control does not function.	
P1805	Brake switch	—	—	—	ECM controls the electric throttle control actuator by regulating the throttle opening to a small range. Therefore, acceleration will be poor.	
					Vehicle condition	Driving condition
					When engine is idling	Normal
					When accelerating	Poor acceleration
P2004	Intake manifold runner control valve	—	×	×	—	
P2100 P2103	Throttle control motor relay	—	—	—	ECM stops the electric throttle control actuator control, throttle valve is maintained at a fixed opening (approx. 5 degrees) by the return spring.	
P2101	Electric throttle control function	—	—	—	ECM stops the electric throttle control actuator control, throttle valve is maintained at a fixed opening (approx. 5 degrees) by the return spring.	

# ECM

< ECU DIAGNOSIS INFORMATION >

[QR25DE]

DTC No.	Detected items	Vehicle behavior			
		Pattern			Others
		A	B	C	
P2118	Throttle control motor	—	—	—	ECM stops the electric throttle control actuator control, throttle valve is maintained at a fixed opening (approx. 5 degrees) by the return spring.
P2119	Electric throttle control actuator	—	×	—	—
P2122 P2123 P2127 P2128 P2138	Accelerator pedal position sensor	—	—	—	The ECM controls the electric throttle control actuator in regulating the throttle opening in order for the idle position to be within +10 degrees. The ECM regulates the opening speed of the throttle valve to be slower than the normal condition. So, the acceleration will be poor.

## DTC Inspection Priority Chart

INFOID:000000011277888

If some DTCs are displayed at the same time, perform inspections one by one based on the following priority chart.

Priority	DTC	Detected items
1	U0101, U1001	CAN communication line
	P0101, P0102, P0103	Mass air flow sensor
	P0111, P0112, P0113, P0127	Intake air temperature sensor
	P0116, P0117, P0118, P0125	Engine coolant temperature sensor
	P0122, P0123, P0222, P0223, P1225, P1226, P2135	Throttle position sensor
	P0128	Thermostat function
	P0181, P0182, P0183	Fuel tank temperature sensor
	P0196, P0197, P0198	Engine oil temperature sensor
	P0327, P0328	Knock sensor
	P0335	Crankshaft position sensor (POS)
	P0340	Camshaft position sensor (PHASE)
	P0460, P0461, P0462, P0463	Fuel level sensor
	P0500	Vehicle speed sensor
	P0520	Engine oil pressure sensor
	P0603, P0604, P0605, P0606, P0607, P060A, P060B, P2610	ECM
	P0643	Sensor power supply
	P0850	Transmission range switch
	P1078	Exhaust valve timing control position sensor
	P1610, P1611, P1612, P1615	NATS
	P2014, P2016, P2017, P2018	Intake manifold runner control valve position sensor
P2122, P2123, P2127, P2128, P2138	Accelerator pedal position sensor	

Priority	DTC	Detected items
2	P0030, P0031, P0032	Air fuel ratio (A/F) sensor 1 heater
	P0037, P0038	Heated oxygen sensor 2 heater
	P0075	Intake valve timing control solenoid valve/Intake valve timing intermediate lock control solenoid valve
	P0078	Exhaust valve timing control solenoid valve
	P0130, P0131, P0132, P014C, P014D, P015A, P015B, P117A, P2096, P2097	Air fuel ratio (A/F) sensor 1
	P0137, P0138, P0139	Heated oxygen sensor 2
	P0441	EVAP control system purge flow monitoring
	P0443, P0444, P0445	EVAP canister purge volume control solenoid valve
	P0447, P0448	EVAP canister vent control valve
	P0451, P0452, P0453	EVAP control system pressure sensor
	P1217	Engine over temperature (OVERHEAT)
	P1805	Brake switch
	P2004	Intake manifold runner control valve
	P2100, P2103	Throttle control motor relay
	P2101	Electric throttle control function
3	P2118	Throttle control motor
	P0011, P052A, P052B	Intake valve timing control
	P0014	Exhaust valve timing control
	P0171, P0172	Fuel injection system function
	P0300, P0301, P0302, P0303, P0304	Misfire
	P0420	Three way catalyst function
	P0456	EVAP control system
	P0506, P0507	Idle speed control system
	P050A, P050B, P050E	Cold start control
	P0524	Engine oil pressure
	P1148	Closed loop control
	P1212	TCS communication line
	P1564	ASCD steering switch
	P1572	ASCD brake switch
	P1574	ASCD vehicle speed sensor
P1715	Input speed sensor	
P2119	Electric throttle control actuator	

DTC Index

INFOID:000000011277889

×:Applicable —: Not applicable

DTC*1		Items (CONSULT screen terms)	SRT code	Trip	MIL	Permanent DTC group*4	Reference page
CONSULT GST*2	ECM*3						
U0101	0101*5	LOST COMM (TCM)	—	1	×	B	<a href="#">EC-172</a>
U1001	1001*5	CAN COMM CIRCUIT	—	2 or 1	—	—	<a href="#">EC-173</a>
U1040	1040*5	ENG COMM CIRCUIT	—	2	—	—	<a href="#">EC-174</a>
U1044	1044*5	ENG COMM CIRCUIT	—	2	—	—	<a href="#">EC-176</a>



# ECM

< ECU DIAGNOSIS INFORMATION >

[QR25DE]

DTC*1		Items (CONSULT screen terms)	SRT code	Trip	MIL	Permanent DTC group*4	Reference page	
CONSULT GST*2	ECM*3							
U1050	1050*5	LIN COMMUNICATION	—	2	—	—	<a href="#">EC-178</a>	EC
U1051	1051*5	LIN COMMUNICATION	—	2	—	—	<a href="#">EC-178</a>	
<b>P0000</b>	<b>0000</b>	<b>NO DTC IS DETECTED. FURTHER TESTING MAY BE REQUIRED.</b>	—	—	<b>Flashing*6</b>	—	—	C
P0011	0011	INT/V TIM CONT-B1	×	2	×	B	<a href="#">EC-180</a>	D
P0014	0014	EXH/V TIM CONT-B1	—	2	×	B	<a href="#">EC-184</a>	
P0030	0030	A/F SEN1 HTR (B1)	—	2	×	B	<a href="#">EC-188</a>	E
P0031	0031	A/F SEN1 HTR (B1)	—	2	×	B	<a href="#">EC-188</a>	
P0032	0032	A/F SEN1 HTR (B1)	—	2	×	B	<a href="#">EC-188</a>	F
P0037	0037	HO2S2 HTR (B1)	—	2	×	B	<a href="#">EC-191</a>	
P0038	0038	HO2S2 HTR (B1)	—	2	×	B	<a href="#">EC-191</a>	G
P0075	0075	INT/V TIM V/CIR-B1	—	2	×	B	<a href="#">EC-194</a>	
P0078	0078	EX V/T ACT/CIRC-B1	—	2	×	B	<a href="#">EC-198</a>	H
P0101	0101	MAF SEN/CIRCUIT-B1	—	2	×	B	<a href="#">EC-201</a>	
P0102	0102	MAF SEN/CIRCUIT-B1	—	1	×	B	<a href="#">EC-205</a>	I
P0103	0103	MAF SEN/CIRCUIT-B1	—	1	×	B	<a href="#">EC-205</a>	
P0111	0111	IAT SENSOR 1 B1	—	2	×	A	<a href="#">EC-209</a>	J
P0112	0112	IAT SEN/CIRCUIT-B1	—	2	×	B	<a href="#">EC-211</a>	
P0113	0113	IAT SEN/CIRCUIT-B1	—	2	×	B	<a href="#">EC-211</a>	K
P0116	0116	ECT SENSOR	—	2	×	A	<a href="#">EC-214</a>	
P0117	0117	ECT SEN/CIRC	—	1	×	B	<a href="#">EC-216</a>	L
P0118	0118	ECT SEN/CIRC	—	1	×	B	<a href="#">EC-216</a>	
P0122	0122	TP SEN 2/CIRC-B1	—	1	×	B	<a href="#">EC-219</a>	M
P0123	0123	TP SEN 2/CIRC-B1	—	1	×	B	<a href="#">EC-219</a>	
P0125	0125	ECT SENSOR	—	2	×	B	<a href="#">EC-222</a>	N
P0127	0127	IAT SENSOR-B1	—	2	×	B	<a href="#">EC-224</a>	
P0128	0128	THERMSTAT FNCTN	—	2	×	A	<a href="#">EC-226</a>	O
P0130	0130	A/F SENSOR1 (B1)	—	2	×	A	<a href="#">EC-229</a>	
P0131	0131	A/F SENSOR1 (B1)	—	2	×	B	<a href="#">EC-233</a>	P
P0132	0132	A/F SENSOR1 (B1)	—	2	×	B	<a href="#">EC-236</a>	
P0137	0137	HO2S2 (B1)	×	2	×	A	<a href="#">EC-239</a>	
P0138	0138	HO2S2 (B1)	×	2	×	A	<a href="#">EC-245</a>	
P0139	0139	HO2S2 (B1)	×	2	×	A	<a href="#">EC-252</a>	
P014C	014C	A/F SENSOR1 (B1)	×	2	×	A	<a href="#">EC-258</a>	
P014D	014D	A/F SENSOR1 (B1)	×	2	×	A	<a href="#">EC-258</a>	
P015A	015A	A/F SENSOR1 (B1)	×	2	×	A	<a href="#">EC-258</a>	
P015B	015B	A/F SENSOR1 (B1)	×	2	×	A	<a href="#">EC-258</a>	
P0171	0171	FUEL SYS-LEAN-B1	—	2	×	B	<a href="#">EC-263</a>	
P0172	0172	FUEL SYS-RICH-B1	—	2	×	B	<a href="#">EC-268</a>	
P0181	0181	FTT SENSOR	—	2	×	A and B	<a href="#">EC-273</a>	
P0182	0182	FTT SEN/CIRCUIT	—	2	×	B	<a href="#">EC-277</a>	
P0183	0183	FTT SEN/CIRCUIT	—	2	×	B	<a href="#">EC-277</a>	

# ECM

< ECU DIAGNOSIS INFORMATION >

[QR25DE]

DTC*1		Items (CONSULT screen terms)	SRT code	Trip	MIL	Permanent DTC group*4	Reference page
CONSULT GST*2	ECM*3						
P0196	0196	EOT SENSOR	—	2	×	A and B	<a href="#">EC-280</a>
P0197	0197	EOT SEN/CIRC	—	2	×	B	<a href="#">EC-284</a>
P0198	0198	EOT SEN/CIRC	—	2	×	B	<a href="#">EC-284</a>
P0222	0222	TP SEN 1/CIRC-B1	—	1	×	B	<a href="#">EC-287</a>
P0223	0223	TP SEN 1/CIRC-B1	—	1	×	B	<a href="#">EC-287</a>
P0300	0300	MULTI CYL MISFIRE	—	1 or 2	×	B	<a href="#">EC-290</a>
P0301	0301	CYL 1 MISFIRE	—	1 or 2	×	B	<a href="#">EC-290</a>
P0302	0302	CYL 2 MISFIRE	—	1 or 2	×	B	<a href="#">EC-290</a>
P0303	0303	CYL 3 MISFIRE	—	1 or 2	×	B	<a href="#">EC-290</a>
P0304	0304	CYL 4 MISFIRE	—	1 or 2	×	B	<a href="#">EC-290</a>
P0327	0327	KNOCK SEN/CIRC-B1	—	2	—	—	<a href="#">EC-296</a>
P0328	0328	KNOCK SEN/CIRC-B1	—	2	—	—	<a href="#">EC-296</a>
P0335	0335	CKP SEN/CIRCUIT	—	2	×	B	<a href="#">EC-298</a>
P0340	0340	CMP SEN/CIRC-B1	—	2	×	B	<a href="#">EC-301</a>
P0420	0420	TW CATALYST SYS-B1	×	2	×	A	<a href="#">EC-304</a>
P0441	0441	EVAP PURG FLOW/MON	×	2	×	A	<a href="#">EC-309</a>
P0443	0443	PURG VOLUME CONT/V	—	2	×	A	<a href="#">EC-314</a>
P0444	0444	PURG VOLUME CONT/V	—	2	×	B	<a href="#">EC-319</a>
P0445	0445	PURG VOLUME CONT/V	—	2	×	B	<a href="#">EC-319</a>
P0447	0447	VENT CONTROL VALVE	—	2	×	B	<a href="#">EC-322</a>
P0448	0448	VENT CONTROL VALVE	—	2	×	B	<a href="#">EC-326</a>
P0451	0451	EVAP SYS PRES SEN	—	2	×	A	<a href="#">EC-330</a>
P0452	0452	EVAP SYS PRES SEN	—	2	×	B	<a href="#">EC-334</a>
P0453	0453	EVAP SYS PRES SEN	—	2	×	B	<a href="#">EC-337</a>
P0456	0456	EVAP VERY SML LEAK	×*7	2	×	A	<a href="#">EC-341</a>
P0460	0460	FUEL LEV SEN SLOSH	—	2	×	A	<a href="#">EC-347</a>
P0461	0461	FUEL LEVEL SENSOR	—	2	×	B	<a href="#">EC-349</a>
P0462	0462	FUEL LEVL SEN/CIRC	—	2	×	B	<a href="#">EC-351</a>
P0463	0463	FUEL LEVL SEN/CIRC	—	2	×	B	<a href="#">EC-351</a>
P0500	0500	VEHICLE SPEED SENSOR A*8	—	2	×	B	<a href="#">EC-353</a>
P0506	0506	ISC SYSTEM	—	2	×	B	<a href="#">EC-355</a>
P0507	0507	ISC SYSTEM	—	2	×	B	<a href="#">EC-357</a>
P050A	050A	COLD START CONTROL	—	2	×	A	<a href="#">EC-359</a>
P050B	050B	COLD START CONTROL	—	2	×	A	<a href="#">EC-359</a>
P050E	050E	COLD START CONTROL	—	2	×	A	<a href="#">EC-359</a>
P0520	0520	EOP SENSOR/SWITCH	—	2	—	—	<a href="#">EC-361</a>
P0524	0524	ENGINE OIL PRESSURE	—	1	—	—	<a href="#">EC-364</a>
P052A	052A	CAMSHAFT POSITION TIMING B1	—	2	×	B	<a href="#">EC-367</a>
P052B	052B	CAMSHAFT POSITION TIMING B1	—	2	×	B	<a href="#">EC-367</a>
P0603	0603	ECM BACK UP/CIRCUIT*9	—	2	× or —	B	<a href="#">EC-373</a>
P0604	0604	ECM	—	1	×	B	<a href="#">EC-375</a>
P0605	0605	ECM	—	1 or 2	× or —	B	<a href="#">EC-376</a>

# ECM

< ECU DIAGNOSIS INFORMATION >

[QR25DE]

DTC*1		Items (CONSULT screen terms)	SRT code	Trip	MIL	Permanent DTC group*4	Reference page	
CONSULT GST*2	ECM*3							
P0606	0606	CONTROL MODULE	—	1	× or —	B	<a href="#">EC-377</a>	A
P0607	0607	ECM	—	1 or 2	× or —	B	<a href="#">EC-379</a>	EC
P060A	060A	CONTROL MODULE	—	1 or 2	×	B	<a href="#">EC-380</a>	
P060B	060B	CONTROL MODULE	—	1	×	B	<a href="#">EC-381</a>	C
P062F	062F	CONTROL MODULE	—	2	×	A	<a href="#">EC-373</a>	
P0643	0643	SENSOR POWER/CIRC	—	1	×	B	<a href="#">EC-382</a>	D
P0850	0850	P-N POS SW/CIRCUIT	—	2	×	B	<a href="#">EC-385</a>	
P1078	1078	EXH TIM SEN/CIRC-B1	—	2	×	B	<a href="#">EC-388</a>	
P1148	1148	CLOSED LOOP-B1	—	1	×	A	<a href="#">EC-391</a>	E
P117A	117A	AIR FUEL RATIO B1	—	2	×	A	<a href="#">EC-392</a>	
P1212	1212	TCS/CIRC	—	2	—	—	<a href="#">EC-398</a>	F
P1217	1217	ENG OVER TEMP	—	1	×	B	<a href="#">EC-400</a>	
P1225	1225	CTP LEARNING-B1	—	2	—	—	<a href="#">EC-403</a>	
P1226	1226	CTP LEARNING-B1	—	2	—	—	<a href="#">EC-404</a>	G
P155D	155D	GENERATOR	—	2	—	—	<a href="#">EC-405</a>	
P1564	1564	ASCD SW	—	1	—	—	<a href="#">EC-406</a>	H
P1568	1568	ICC COMMAND VALUE	—	1	—	—	<a href="#">EC-409</a>	
P1572	1572	ASCD BRAKE SW	—	1	—	—	<a href="#">EC-411</a>	
P1574	1574	ASCD VHL SPD SEN	—	1	—	—	<a href="#">EC-417</a>	I
P1610	1610	LOCK MODE	—	2	—	—	<a href="#">SEC-68,</a> <a href="#">SEC-161</a>	
P1611	1611	ID DISCORD,IMMU-ECM	—	2	—	—	<a href="#">SEC-69,</a> <a href="#">SEC-162</a>	J
P1612	1612	CHAIN OF ECM-IMMU	—	2	—	—	<a href="#">SEC-70,</a> <a href="#">SEC-163</a>	K
P161D	161D	IMMOBILIZER	—	2	—	—	<a href="#">SEC-71,</a> <a href="#">SEC-164</a>	
P161E	161E	IMMOBILIZER	—	2	—	—	<a href="#">SEC-72,</a> <a href="#">SEC-165</a>	L
P161F	161F	IMMOBILIZER	—	2	—	—	<a href="#">SEC-73,</a> <a href="#">SEC-166</a>	M
P1715	1715	IN PULY SPEED	—	2	—	—	<a href="#">EC-419</a>	
P1805	1805	BRAKE SW/CIRCUIT	—	2	—	—	<a href="#">EC-421</a>	
P2004	2004	TUMBLE CONT/V	—	2	×	B	<a href="#">EC-423</a>	N
P2014	2014	IN/MANIFOLD RUNNER POS SEN B1	—	2	×	B	<a href="#">EC-426</a>	
P2016	2016	IN/MANIFOLD RUNNER POS SEN B1	—	2	×	B	<a href="#">EC-426</a>	O
P2017	2017	IN/MANIFOLD RUNNER POS SEN B1	—	2	×	B	<a href="#">EC-426</a>	
P2018	2018	IN/MANIFOLD RUNNER POS SEN B1	—	2	×	B	<a href="#">EC-426</a>	
P2096	2096	POST CATALYST FUEL TRIM SYS B1	—	2	×	A	<a href="#">EC-429</a>	P
P2097	2097	POST CATALYST FUEL TRIM SYS B1	—	2	×	A	<a href="#">EC-429</a>	
P2100	2100	ETC MOT PWR-B1	—	1	×	B	<a href="#">EC-433</a>	
P2101	2101	ETC FNCTN/CIRC-B1	—	1	×	B	<a href="#">EC-436</a>	
P2103	2103	ETC MOT PWR-B1	—	1	×	B	<a href="#">EC-433</a>	
P2118	2118	ETC MOT-B1	—	1	×	B	<a href="#">EC-439</a>	

DTC*1		Items (CONSULT screen terms)	SRT code	Trip	MIL	Permanent DTC group*4	Reference page
CONSULT GST*2	ECM*3						
P2119	2119	ETC ACTR-B1	—	1	×	B	<a href="#">EC-441</a>
P2122	2122	APP SEN 1/CIRC	—	1	×	B	<a href="#">EC-443</a>
P2123	2123	APP SEN 1/CIRC	—	1	×	B	<a href="#">EC-443</a>
P2127	2127	APP SEN 2/CIRC	—	1	×	B	<a href="#">EC-446</a>
P2128	2128	APP SEN 2/CIRC	—	1	×	B	<a href="#">EC-446</a>
P2135	2135	TP SENSOR-B1	—	1	×	B	<a href="#">EC-449</a>
P2138	2138	APP SENSOR	—	1	×	B	<a href="#">EC-452</a>
P2610	2610	ECM/PCM INTERNAL ENG OFF TIMER	—	2	×	A and B	<a href="#">EC-456</a>

\*1: 1st trip DTC No. is the same as DTC No.

\*2: This number is prescribed by SAE J1979/ ISO 15031-5.

\*3: In Diagnostic Test Mode II (Self-diagnostic results), this number is controlled by NISSAN.

\*4: Refer to [EC-154. "Description"](#).

\*5: The troubleshooting for this DTC needs CONSULT.

\*6: When the ECM is in the mode that displays SRT status, MIL may blink. For details, Refer to [EC-66. "On Board Diagnosis Function"](#).

\*7: SRT code will not be set if the self-diagnostic result is NG.

\*8: When the fail-safe operations for both self-diagnoses occur, the MIL illuminates.

\*9: This self-diagnosis is not for ECM power supply circuit, even though "ECM BACK UP/CIRCUIT" is displayed on CONSULT screen.

## Test Value and Test Limit

INFOID:000000011518225

The following is the information specified in Service \$06 of SAE J1979/ISO 15031-5.

The test value is a parameter used to determine whether a system/circuit diagnostic test is OK or NG while being monitored by the ECM during self-diagnosis. The test limit is a reference value which is specified as the maximum or minimum value and is compared with the test value being monitored.

These data (test value and test limit) are specified by On Board Monitor ID (OBDMID), Test ID (TID), Unit and Scaling ID and can be displayed on the GST screen.

The items of the test value and test limit will be displayed with GST screen which items are provided by the ECM. (e.g., if bank 2 is not applied on this vehicle, only the items of bank 1 are displayed)

# ECM

< ECU DIAGNOSIS INFORMATION >

[QR25DE]

Item	OBD-MID	Self-diagnostic test item	DTC	Test value and Test limit (GST display)		Description
				TID	Unit and Scaling ID	
HO2S	01H	Air fuel ratio (A/F) sensor 1 (Bank 1)	P0131	83H	0BH	Minimum sensor output voltage for test cycle
			P0131	84H	0BH	Maximum sensor output voltage for test cycle
			P0130	85H	0BH	Minimum sensor output voltage for test cycle
			P0130	86H	0BH	Maximum sensor output voltage for test cycle
			P0133	87H	04H	Response rate: Response ratio (lean to rich)
			P0133	88H	04H	Response rate: Response ratio (rich to lean)
			P2A00 or P2096	89H	84H	The amount of shift in air fuel ratio (too lean)
			P2A00 or P2097	8AH	84H	The amount of shift in air fuel ratio (too rich)
			P0130	8BH	0BH	Difference in sensor output voltage
			P0133	8CH	83H	Response gain at the limited frequency
			P014C	8DH	04H	O2 sensor slow response - Rich to lean bank 1 sensor 1
			P014C	8EH	04H	O2 sensor slow response - Rich to lean bank 1 sensor 1
			P014D	8FH	84H	O2 sensor slow response - Lean to rich bank 1 sensor 1
			P014D	90H	84H	O2 sensor slow response - Lean to rich bank 1 sensor 1
			P015A	91H	01H	O2 sensor delayed response - Rich to lean bank 1 sensor 1
			P015A	92H	01H	O2 sensor delayed response - Rich to lean bank 1 sensor 1
			P015B	93H	01H	O2 sensor delayed response - Lean to rich bank 1 sensor 1
			P015B	94H	01H	O2 sensor delayed response - Lean to rich bank 1 sensor 1
			P0133	95H	04H	Response rate: Response ratio (lean to rich)
			P0133	96H	84H	Response rate: Response ratio (rich to lean)

A  
EC  
C  
D  
E  
F  
G  
H  
I  
J  
K  
L  
M  
N  
O  
P

# ECM

< ECU DIAGNOSIS INFORMATION >

[QR25DE]

Item	OBD-MID	Self-diagnostic test item	DTC	Test value and Test limit (GST display)		Description
				TID	Unit and Scaling ID	
HO2S	02H	Heated oxygen sensor 2 (Bank 1)	P0138	07H	0CH	Minimum sensor output voltage for test cycle
			P0137	08H	0CH	Maximum sensor output voltage for test cycle
			P0138	80H	0CH	Sensor output voltage
			P0139	81H	0CH	Difference in sensor output voltage
			P0139	82H	11H	Rear O2 sensor delay response diagnosis
	03H	Heated oxygen sensor 3 (Bank 1)	P0143	07H	0CH	Minimum sensor output voltage for test cycle
			P0144	08H	0CH	Maximum sensor output voltage for test cycle
			P0146	80H	0CH	Sensor output voltage
			P0145	81H	0CH	Difference in sensor output voltage
	05H	Air fuel ratio (A/F) sensor 1 (Bank 2)	P0151	83H	0BH	Minimum sensor output voltage for test cycle
			P0151	84H	0BH	Maximum sensor output voltage for test cycle
			P0150	85H	0BH	Minimum sensor output voltage for test cycle
			P0150	86H	0BH	Maximum sensor output voltage for test cycle
			P0153	87H	04H	Response rate: Response ratio (lean to rich)
			P0153	88H	04H	Response rate: Response ratio (rich to lean)
			P2A03 or P2098	89H	84H	The amount of shift in air fuel ratio (too lean)
			P2A03 or P2099	8AH	84H	The amount of shift in air fuel ratio (too rich)
			P0150	8BH	0BH	Difference in sensor output voltage
			P0153	8CH	83H	Response gain at the limited frequency
			P014E	8DH	04H	O2 sensor slow response - Rich to lean bank 2 sensor 1
			P014E	8EH	04H	O2 sensor slow response - Rich to lean bank 2 sensor 1
			P014F	8FH	84H	O2 sensor slow response - Lean to rich bank 2 sensor 1
			P014F	90H	84H	O2 sensor slow response - Lean to rich bank 2 sensor 1
			P015C	91H	01H	O2 sensor delayed response - Rich to lean bank 2 sensor 1
			P015C	92H	01H	O2 sensor delayed response - Rich to lean bank 2 sensor 1
			P015D	93H	01H	O2 sensor delayed response - Lean to rich bank 2 sensor 1

# ECM

< ECU DIAGNOSIS INFORMATION >

[QR25DE]

Item	OBD-MID	Self-diagnostic test item	DTC	Test value and Test limit (GST display)		Description	
				TID	Unit and Scaling ID		
HO2S	05H	Air fuel ratio (A/F) sensor 1 (Bank 2)	P015D	94H	01H	O2 sensor delayed response - Lean to rich bank 2 sensor 1	
			P0153	95H	04H	Response rate: Response ratio (lean to rich)	
			P0153	96H	84H	Response rate: Response ratio (rich to lean)	
	06H	Heated oxygen sensor 2 (Bank 2)	P0158	07H	0CH	Minimum sensor output voltage for test cycle	
			P0157	08H	0CH	Maximum sensor output voltage for test cycle	
			P0158	80H	0CH	Sensor output voltage	
			P0159	81H	0CH	Difference in sensor output voltage	
			P0159	82H	11H	Rear O2 sensor delay response diagnosis	
	07H	Heated oxygen sensor 3 (Bank2)	P0163	07H	0CH	Minimum sensor output voltage for test cycle	
			P0164	08H	0CH	Maximum sensor output voltage for test cycle	
			P0166	80H	0CH	Sensor output voltage	
			P0165	81H	0CH	Difference in sensor output voltage	
	CATA- LYST	21H	Three way catalyst function (Bank1)	P0420	80H	01H	O2 storage index
				P0420	82H	01H	Switching time lag engine exhaust index value
				P2423	83H	0CH	Difference in 3rd O2 sensor output voltage
P2423				84H	84H	O2 storage index in HC trap catalyst	
22H		Three way catalyst function (Bank2)	P0430	80H	01H	O2 storage index	
			P0430	82H	01H	Switching time lag engine exhaust index value	
			P2424	83H	0CH	Difference in 3rd O2 sensor output voltage	
			P2424	84H	84H	O2 storage index in HC trap catalyst	
EGR SYSTEM	31H	EGR function	P0400	80H	96H	Low flow faults: EGR temp change rate (short term)	
			P0400	81H	96H	Low flow faults: EGR temp change rate (long term)	
			P0400	82H	96H	Low flow faults: Difference between max EGR temp and EGR temp under idling condition	
			P0400	83H	96H	Low flow faults: Max EGR temp	
			P1402	84H	96H	High Flow Faults: EGR temp increase rate	
			P0402	85H	FCH	EGR differential pressure high flow	
			P0401	86H	37H	EGR differential pressure low flow	
			P2457	87H	96H	EGR temperature	

A  
EC  
C  
D  
E  
F  
G  
H  
I  
J  
K  
L  
M  
N  
O  
P

**ECM**

< ECU DIAGNOSIS INFORMATION >

[QR25DE]

Item	OBD-MID	Self-diagnostic test item	DTC	Test value and Test limit (GST display)		Description
				TID	Unit and Scaling ID	
VVT SYSTEM	35H	VVT Monitor (Bank1)	P0011	80H	9DH	VTC intake function diagnosis (VTC alignment check diagnosis)
			P0014	81H	9DH	VTC exhaust function diagnosis (VTC alignment check diagnosis)
			P0011	82H	9DH	VTC intake function diagnosis (VTC drive failure diagnosis)
			P0014	83H	9DH	VTC exhaust function diagnosis (VTC drive failure diagnosis)
			P100A	84H	10H	VEL slow response diagnosis
			P1090	85H	10H	VEL servo system diagnosis
			P0011	86H	9DH	VTC intake intermediate lock function diagnosis (VTC intermediate position alignment check diagnosis)
			Advanced: P052A Retarded: P052B	87H	9DH	VTC intake intermediate lock system diagnosis (VTC intermediate lock position check diagnosis)
	36H	VVT Monitor (Bank2)	P0021	80H	9DH	VTC intake function diagnosis (VTC alignment check diagnosis)
			P0024	81H	9DH	VTC exhaust function diagnosis (VTC alignment check diagnosis)
			P0021	82H	9DH	VTC intake function diagnosis (VTC drive failure diagnosis)
			P0024	83H	9DH	VTC exhaust function diagnosis (VTC drive failure diagnosis)
			P100B	84H	10H	VEL slow response diagnosis
			P1093	85H	10H	VEL servo system diagnosis
P0021			86H	9DH	VTC intake intermediate lock function diagnosis (VTC intermediate position alignment check diagnosis)	
		Advanced: P052C Retarded: P052D	87H	9DH	VTC intake intermediate lock system diagnosis (VTC intermediate lock position check diagnosis)	
EVAP SYSTEM	39H	EVAP control system leak (Cap Off)	P0455	80H	0CH	Difference in pressure sensor output voltage before and after pull down
	3BH	EVAP control system leak (Small leak)	P0442	80H	05H	Leak area index (for more than 0.04 inch)
	3CH	EVAP control system leak (Very small leak)	P0456	80H	05H	Leak area index (for more than 0.02 inch)
			P0456	81H	FDH	Maximum internal pressure of EVAP system during monitoring
			P0456	82H	FDH	Internal pressure of EVAP system at the end of monitoring
3DH	Purge flow system	P0441	83H	0CH	Difference in pressure sensor output voltage before and after vent control valve close	



# ECM

< ECU DIAGNOSIS INFORMATION >

[QR25DE]

Item	OBD-MID	Self-diagnostic test item	DTC	Test value and Test limit (GST display)		Description	
				TID	Unit and Scaling ID		
O2 SENSOR HEATER	41H	A/F sensor 1 heater (Bank 1)	Low Input: P0031 High Input: P0032	81H	0BH	Converted value of heater electric current to voltage	
			P0030	83H	0BH	A/F sensor heater circuit malfunction	
	42H	Heated oxygen sensor 2 heater (Bank 1)	Low Input: P0037 High Input: P0038	80H	0CH	Converted value of heater electric current to voltage	
			P0141	81H	14H	Rear O2 sensor internal impedance	
	43H	Heated oxygen sensor 3 heater (Bank 1)	P0043	80H	0CH	Converted value of heater electric current to voltage	
	45H	A/F sensor 1 heater (Bank 2)	Low Input: P0051 High Input: P0052	81H	0BH	Converted value of heater electric current to voltage	
			P0036	83H	0BH	A/F sensor heater circuit malfunction	
	46H	Heated oxygen sensor 2 heater (Bank 2)	Low Input: P0057 High Input: P0058	80H	0CH	Converted value of heater electric current to voltage	
			P0161	81H	14CH	Rear O2 sensor internal impedance	
	47H	Heated oxygen sensor 3 heater (Bank 2)	P0063	80H	0CH	Converted value of heater electric current to voltage	
	SECONDARY AIR	71H	Secondary air system	P0411	80H	01H	Secondary air injection system incorrect flow detected
				Bank1: P0491 Bank2: P0492	81H	01H	Secondary air injection system insufficient flow
P2445				82H	01H	Secondary air injection system pump stuck off	
P2448				83H	01H	Secondary air injection system high airflow	
Bank1: P2440 Bank2: P2442				84H	01H	Secondary air injection system switching valve stuck open	
P2440				85H	01H	Secondary air injection system switching valve stuck open	
P2444				86H	01H	Secondary air injection system pump stuck on	
FUEL SYSTEM	81H	Fuel injection system function (Bank 1)	P0171 or P0172	80H	2FH	Long term fuel trim	
			P0171 or P0172	81H	24H	The number of lambda control clamped	
			P117A / P219A	82H	03H	Cylinder A/F imbalance monitoring	
	82H	Fuel injection system function (Bank 2)	P0174 or P0175	80H	2FH	Long term fuel trim	
			P0174 or P0175	81H	24H	The number of lambda control clamped	
			P117B / P219B	82H	03H	Cylinder A/F imbalance monitoring	

A  
EC  
C  
D  
E  
F  
G  
H  
I  
J  
K  
L  
M  
N  
O  
P

# ECM

< ECU DIAGNOSIS INFORMATION >

[QR25DE]

Item	OBD-MID	Self-diagnostic test item	DTC	Test value and Test limit (GST display)		Description
				TID	Unit and Scaling ID	
MISFIRE	A1H	Multiple cylinder misfires	P0301	80H	24H	Misfiring counter at 1000 revolution of the first cylinder
			P0302	81H	24H	Misfiring counter at 1000 revolution of the second cylinder
			P0303	82H	24H	Misfiring counter at 1000 revolution of the third cylinder
			P0304	83H	24H	Misfiring counter at 1000 revolution of the fourth cylinder
			P0305	84H	24H	Misfiring counter at 1000 revolution of the fifth cylinder
			P0306	85H	24H	Misfiring counter at 1000 revolution of the sixth cylinder
			P0307	86H	24H	Misfiring counter at 1000 revolution of the seventh cylinder
			P0308	87H	24H	Misfiring counter at 1000 revolution of the eighth cylinder
			P0300	88H	24H	Misfiring counter at 1000 revolution of the multiple cylinders
			P0301	89H	24H	Misfiring counter at 200 revolution of the first cylinder
			P0302	8AH	24H	Misfiring counter at 200 revolution of the second cylinder
			P0303	8BH	24H	Misfiring counter at 200 revolution of the third cylinder
			P0304	8CH	24H	Misfiring counter at 200 revolution of the fourth cylinder
			P0305	8DH	24H	Misfiring counter at 200 revolution of the fifth cylinder
			P0306	8EH	24H	Misfiring counter at 200 revolution of the sixth cylinder
			P0307	8FH	24H	Misfiring counter at 200 revolution of the seventh cylinder
			P0308	90H	24H	Misfiring counter at 200 revolution of the eighth cylinder
			P0300	91H	24H	Misfiring counter at 1000 revolution of the single cylinder
			P0300	92H	24H	Misfiring counter at 200 revolution of the single cylinder
			P0300	93H	24H	Misfiring counter at 200 revolution of the multiple cylinders

# ECM

< ECU DIAGNOSIS INFORMATION >

[QR25DE]

Item	OBD-MID	Self-diagnostic test item	DTC	Test value and Test limit (GST display)		Description
				TID	Unit and Scaling ID	
MISFIRE	A2H	No. 1 cylinder misfire	P0301	0BH	24H	EWMA (Exponential Weighted Moving Average) misfire counts for last 10 driving cycles
			P0301	0CH	24H	Misfire counts for last/current driving cycles
	A3H	No. 2 cylinder misfire	P0302	0BH	24H	EWMA (Exponential Weighted Moving Average) misfire counts for last 10 driving cycles
			P0302	0CH	24H	Misfire counts for last/current driving cycles
	A4H	No. 3 cylinder misfire	P0303	0BH	24H	EWMA (Exponential Weighted Moving Average) misfire counts for last 10 driving cycles
			P0303	0CH	24H	Misfire counts for last/current driving cycles
	A5H	No. 4 cylinder misfire	P0304	0BH	24H	EWMA (Exponential Weighted Moving Average) misfire counts for last 10 driving cycles
			P0304	0CH	24H	Misfire counts for last/current driving cycles
	A6H	No. 5 cylinder misfire	P0305	0BH	24H	EWMA (Exponential Weighted Moving Average) misfire counts for last 10 driving cycles
			P0305	0CH	24H	Misfire counts for last/current driving cycles
	A7H	No. 6 cylinder misfire	P0306	0BH	24H	EWMA (Exponential Weighted Moving Average) misfire counts for last 10 driving cycles
			P0306	0CH	24H	Misfire counts for last/current driving cycles
	A8H	No. 7 cylinder misfire	P0307	0BH	24H	EWMA (Exponential Weighted Moving Average) misfire counts for last 10 driving cycles
			P0307	0CH	24H	Misfire counts for last/current driving cycles
	A9H	No. 8 cylinder misfire	P0308	0BH	24H	EWMA (Exponential Weighted Moving Average) misfire counts for last 10 driving cycles
			P0308	0CH	24H	Misfire counts for last/current driving cycles

A  
EC  
C  
D  
E  
F  
G  
H  
I  
J  
K  
L  
M  
N  
O  
P

< WIRING DIAGRAM >

# WIRING DIAGRAM

## ENGINE CONTROL SYSTEM

### Wiring Diagram

INFOID:0000000011277891

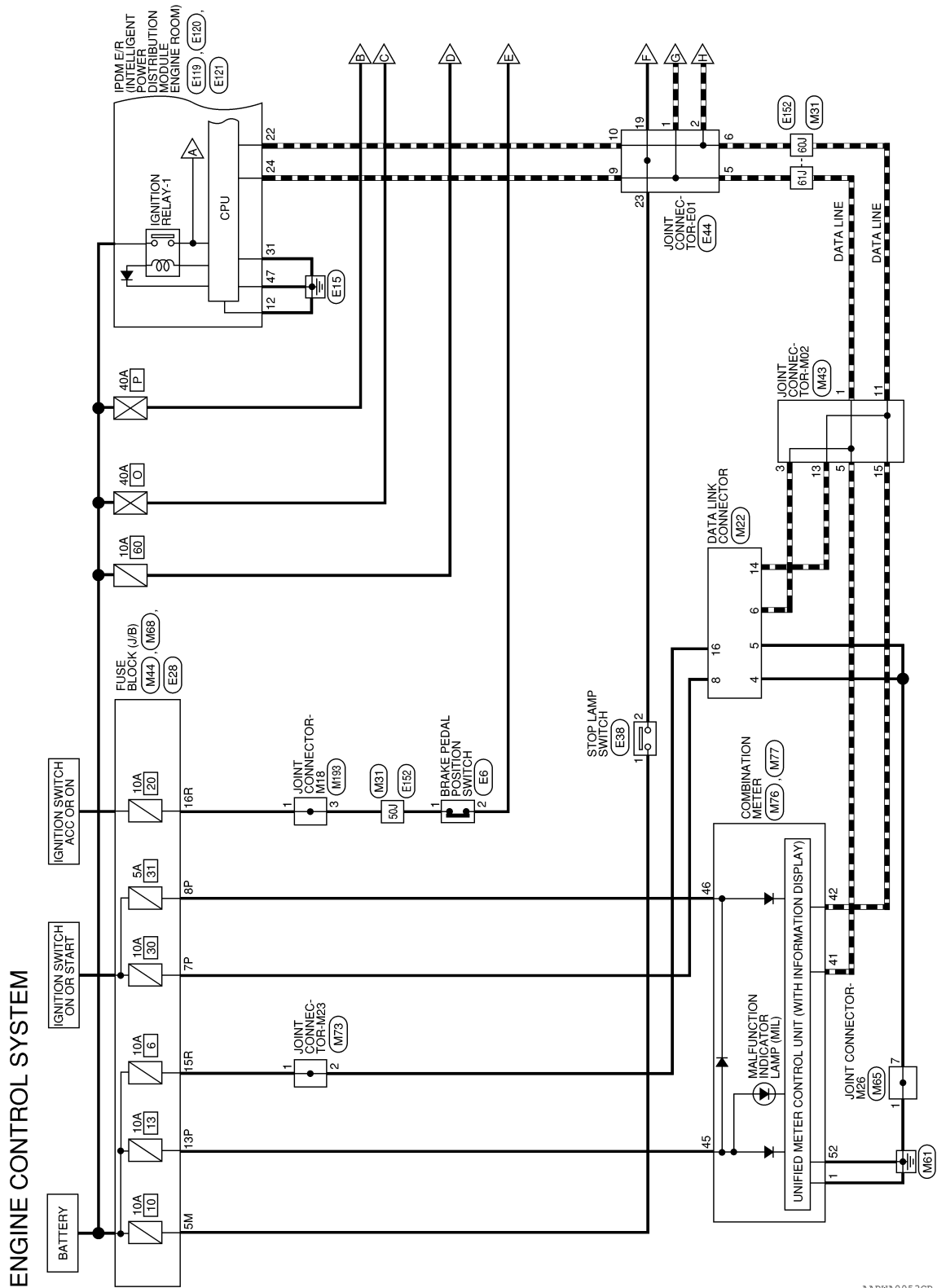

AABWA0953GB

# ENGINE CONTROL SYSTEM

< WIRING DIAGRAM >

[QR25DE]

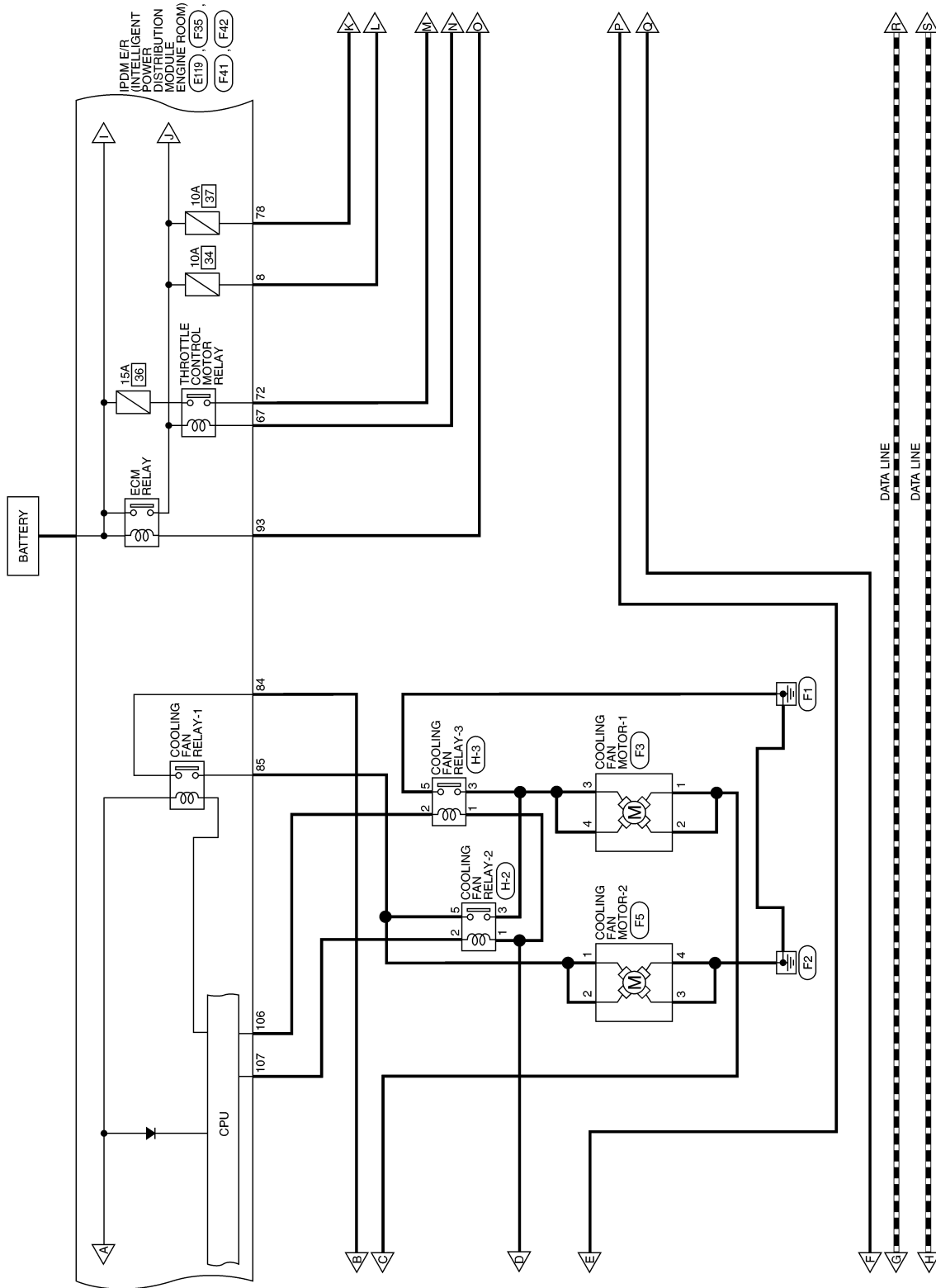

AABWA0954GB

A  
**EC**  
 C  
 D  
 E  
 F  
 G  
 H  
 I  
 J  
 K  
 L  
 M  
 N  
 O  
 P



# ENGINE CONTROL SYSTEM

< WIRING DIAGRAM >

[QR25DE]

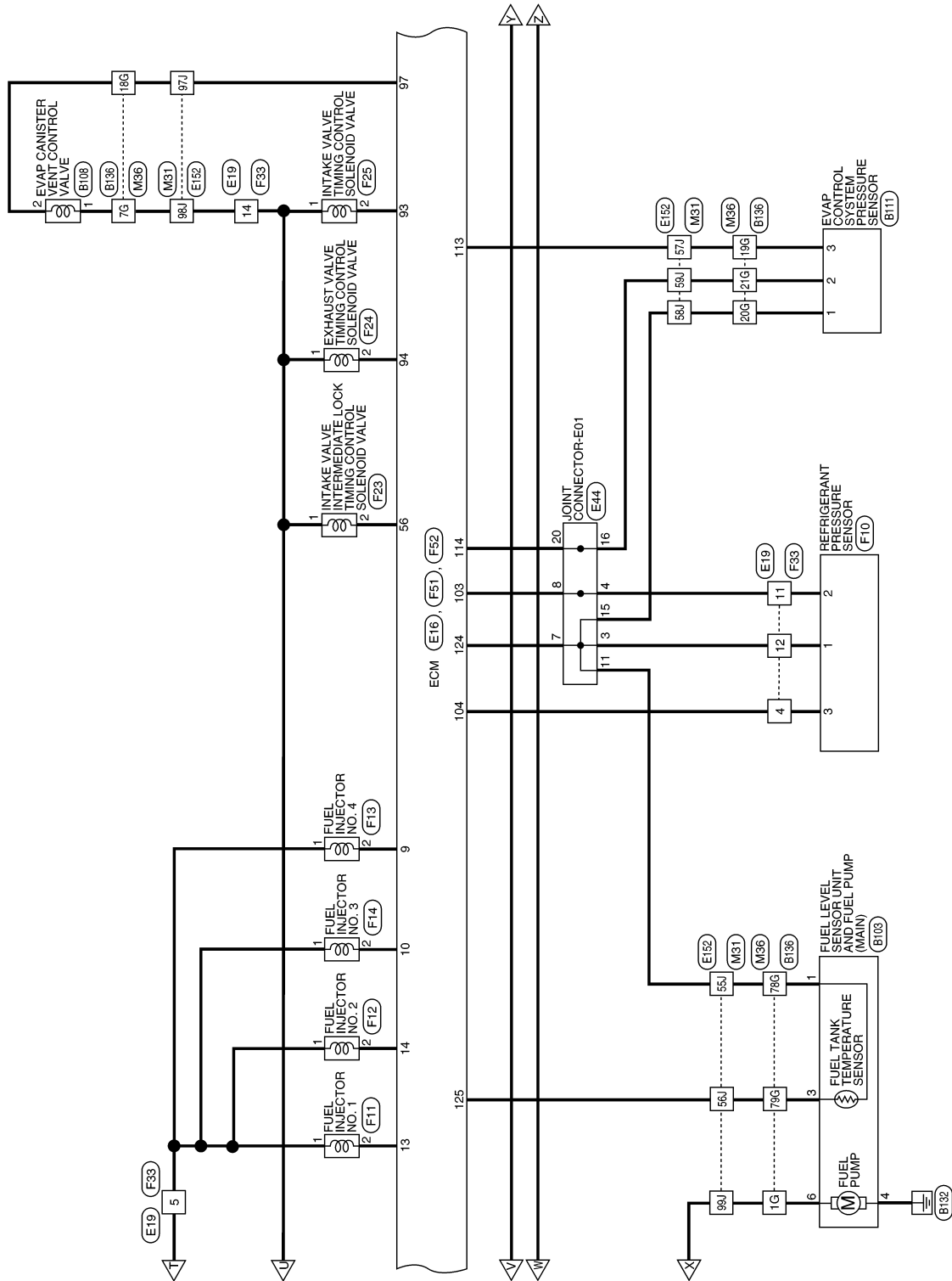

AABWA0956GB

A  
EC  
C  
D  
E  
F  
G  
H  
I  
J  
K  
L  
M  
N  
O  
P

# ENGINE CONTROL SYSTEM

< WIRING DIAGRAM >

[QR25DE]

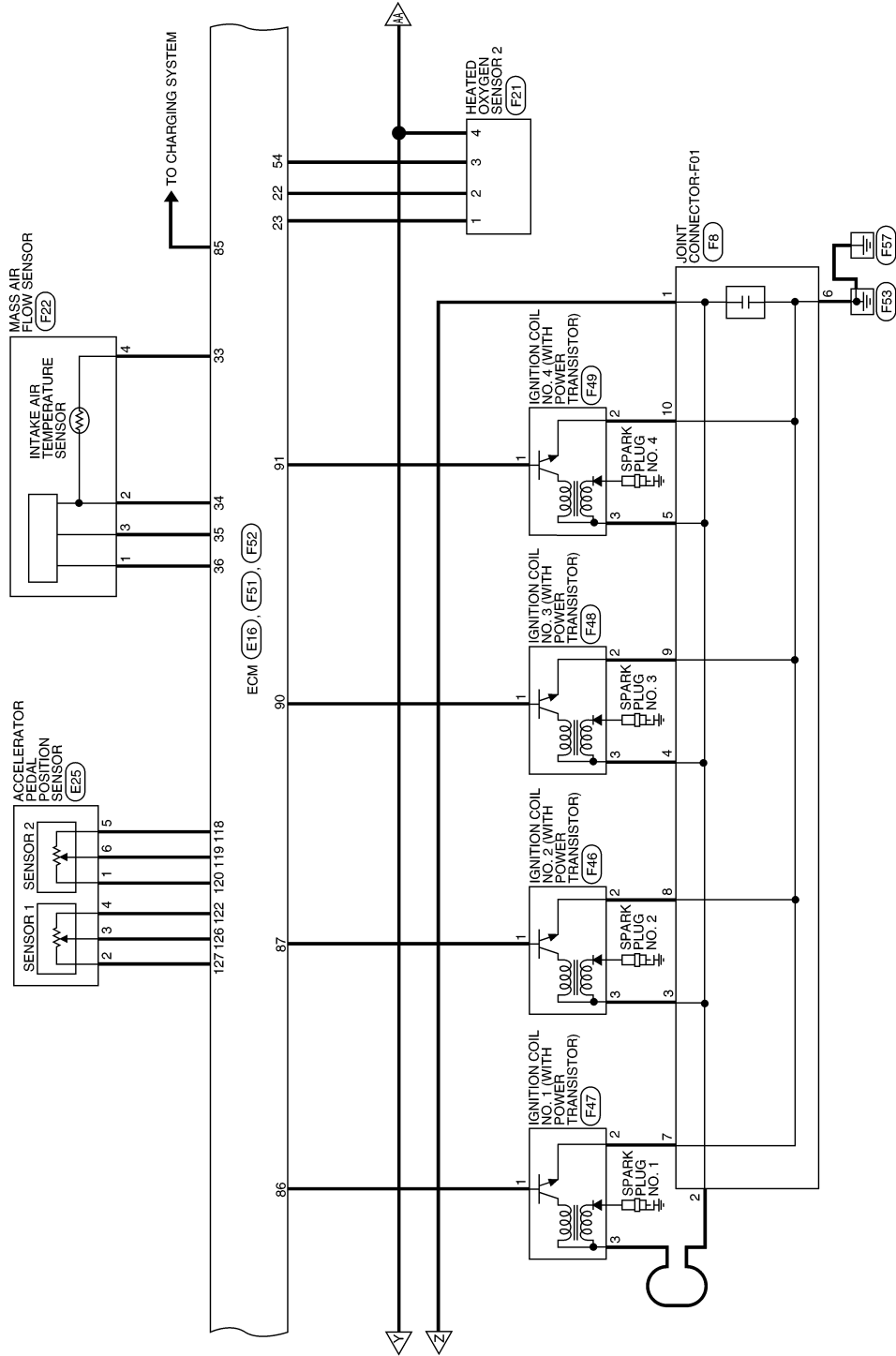

AABWA0957GB



# ENGINE CONTROL SYSTEM

< WIRING DIAGRAM >

[QR25DE]

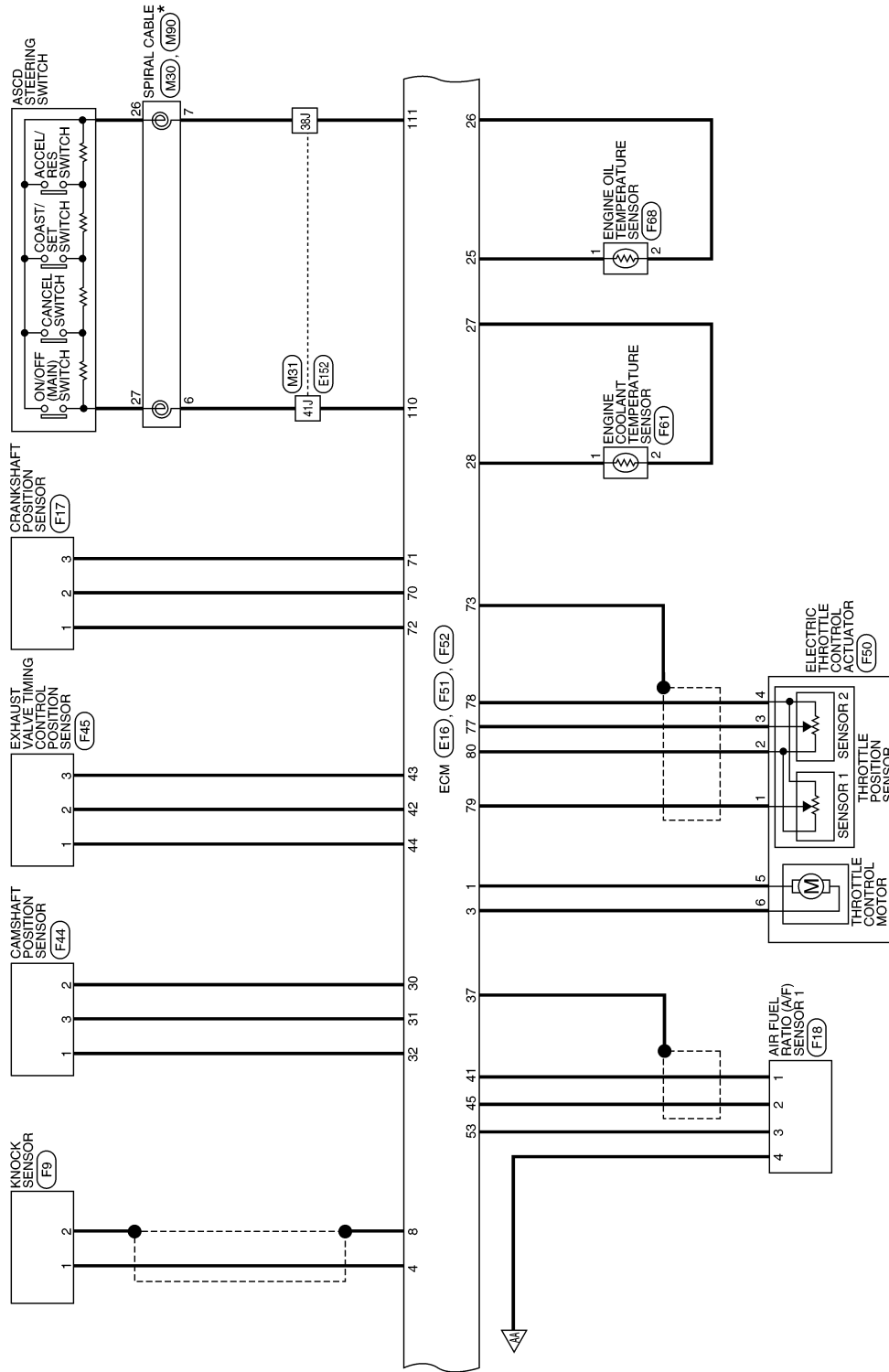

\*: THIS CONNECTOR IS NOT SHOWN IN "HARNES LAYOUT" OF PG SECTION.

AABWA0855GB

A  
EC  
C  
D  
E  
F  
G  
H  
I  
J  
K  
L  
M  
N  
O  
P

# ENGINE CONTROL SYSTEM

< WIRING DIAGRAM >

[QR25DE]

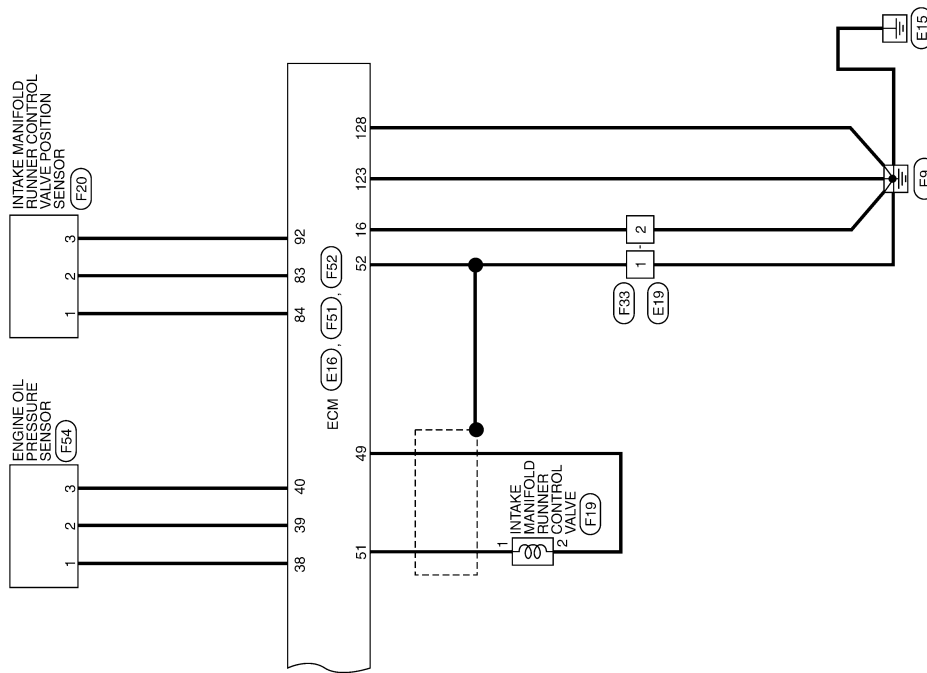

AABWA0856GB

## ENGINE CONTROL SYSTEM CONNECTORS

Connector No.	M22
Connector Name	DATA LINK CONNECTOR
Connector Color	WHITE

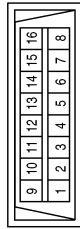

Terminal No.	Color of Wire	Signal Name
4	B	-
5	B	-
6	L	-
8	Y	-
14	P	-
16	W	-

Connector No.	M30
Connector Name	COMBINATION SWITCH (SPIRAL CABLE)
Connector Color	WHITE

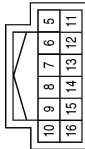

Terminal No.	Color of Wire	Signal Name
6	LA/R	-
7	LA/BR	-

Connector No.	M31
Connector Name	WIRE TO WIRE
Connector Color	WHITE

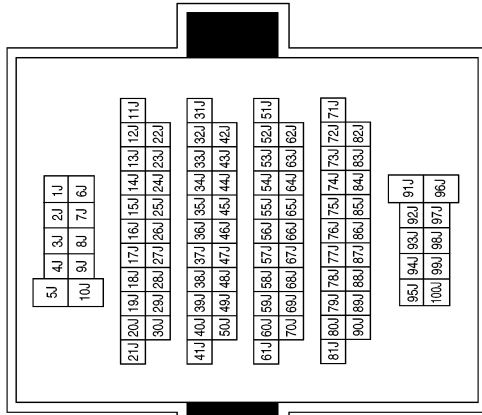

Terminal No.	Color of Wire	Signal Name
38J	LA/BR	-
41J	LA/R	-
50J	GR	-
55J	LA/Y	-
56J	LA/V	-
57J	R	-
58J	W	-
59J	BR	-
60J	P	-
61J	L	-
97J	SB	-
98J	P	-
99J	LA/R	-

AABIA1437GB

A  
EC  
C  
D  
E  
F  
G  
H  
I  
J  
K  
L  
M  
N  
O  
P

# ENGINE CONTROL SYSTEM

< WIRING DIAGRAM >

[QR25DE]

Connector No.	M36
Connector Name	WIRE TO WIRE
Connector Color	WHITE

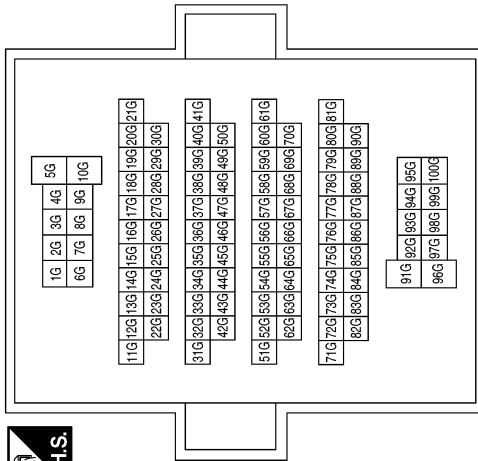

Terminal No.	Color of Wire	Signal Name
1G	LA/R	-
7G	P	-
18G	SB	-
19G	R	-
20G	W	-
21G	BR	-
78G	LA/Y	-
79G	LA/V	-

Connector No.	M43
Connector Name	JOINT CONNECTOR-M02
Connector Color	BLUE

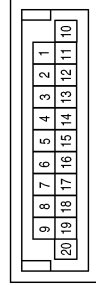

Terminal No.	Color of Wire	Signal Name
1	L	-
3	L	-
5	L	-
11	P	-
13	P	-
15	P	-

Connector No.	M44
Connector Name	FUSE BLOCK (J/B)
Connector Color	WHITE



Terminal No.	Color of Wire	Signal Name
7P	Y	-
8P	LA/BR	-
13P	LA/G	-

Connector No.	M65
Connector Name	JOINT CONNECTOR-M26
Connector Color	WHITE

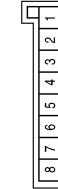

Terminal No.	Color of Wire	Signal Name
1	B	-
7	B	-

Connector No.	M68
Connector Name	FUSE BLOCK (J/B)
Connector Color	BROWN



Terminal No.	Color of Wire	Signal Name
15R	W	-
16R	GR	-

# ENGINE CONTROL SYSTEM

< WIRING DIAGRAM >

[QR25DE]

Connector No.	M73
Connector Name	JOINT CONNECTOR-M23
Connector Color	WHITE

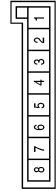

Terminal No.	Color of Wire	Signal Name
1	W	-
2	W	-

Connector No.	M76
Connector Name	COMBINATION METER
Connector Color	WHITE

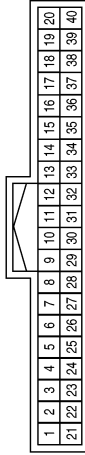

Terminal No.	Color of Wire	Signal Name
1	B	GND1

Connector No.	M77
Connector Name	COMBINATION METER
Connector Color	WHITE

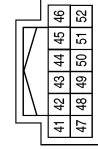

Terminal No.	Color of Wire	Signal Name
41	L	CAN-H
42	P	CAN-L
45	LA/G	ALVUSBAT
46	LA/BR	IGN
52	B	GND2

Connector No.	M90
Connector Name	COMBINATION SWITCH (SPIRAL CABLE)
Connector Color	WHITE

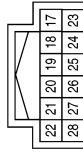

Terminal No.	Color of Wire	Signal Name
26	GR	-
27	V	-

Connector No.	M193
Connector Name	JOINT CONNECTOR-M18
Connector Color	WHITE

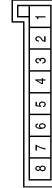

Terminal No.	Color of Wire	Signal Name
1	GR	-
3	GR	-

Connector No.	E6
Connector Name	BRAKE PEDAL POSITION SWITCH
Connector Color	BROWN



Terminal No.	Color of Wire	Signal Name
1	P	-
2	GR	-

AABIA1439GB

A  
EC  
C  
D  
E  
F  
G  
H  
I  
J  
K  
L  
M  
N  
O  
P

# ENGINE CONTROL SYSTEM

< WIRING DIAGRAM >

[QR25DE]

Terminal No.	Color of Wire	Signal Name
117	W	PNP SIGNAL
118	SB	SENSOR POWER SUPPLY
119	Y	ACCELERATOR PEDAL POSITION SENSOR 2
120	LG	SENSOR GROUND
121	BR	POWER SUPPLY FOR ECM
122	V	SENSOR POWER SUPPLY
123	BR	ECM GROUND
124	W	SENSOR GROUND
125	BG	FUEL TANK TEMPERATURE SENSOR
126	GR	ACCELERATOR PEDAL POSITION SENSOR 1
127	R	SENSOR GROUND
128	BR	ECM GROUND

Connector No.	E16
Connector Name	ECM
Connector Color	BLACK

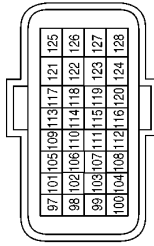

Terminal No.	Color of Wire	Signal Name
97	GR	EVAP CANISTER VENT CONTROL VALVE
98	-	-
99	P	CAN-L
100	L	CAN-H
101	-	-
102	-	-
103	Y	REFRIGERANT PRESSURE SENSOR
104	R	SENSOR POWER SUPPLY
105	-	-
106	-	-
107	-	-
108	-	-
109	LG	IGNITION SWITCH
110	G	ASCD STEERING SWITCH
111	BR	SENSOR GROUND
112	-	-
113	R	SENSOR POWER SUPPLY
114	BR	EVAP CONTROL SYSTEM PRESSURE SENSOR
115	V	STOP LAMP SWITCH
116	GR	BRAKE PEDAL POSITION SWITCH

AAB1A1206GB

# ENGINE CONTROL SYSTEM

< WIRING DIAGRAM >

[QR25DE]

Connector No.	E19
Connector Name	WIRE TO WIRE
Connector Color	BROWN

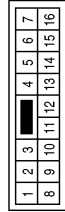

Terminal No.	Color of Wire	Signal Name
1	BR	-
2	BR	-
4	R	-
5	LG	-
6	BG	-
8	W	-
9	R	-
11	Y	-
12	W	-
13	BR	-
14	P	-

Connector No.	E25
Connector Name	ACCELERATOR PEDAL POSITION POSITION (APP) SENSOR
Connector Color	BLACK

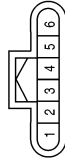

Terminal No.	Color of Wire	Signal Name
1	LG	-
2	R	-
3	GR	-
4	V	-
5	SB	-
6	Y	-

Connector No.	E28
Connector Name	FUSE BLOCK (J/B)
Connector Color	WHITE

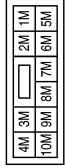

Terminal No.	Color of Wire	Signal Name
5M	V	-

Connector No.	E38
Connector Name	STOP LAMP SWITCH
Connector Color	WHITE



Terminal No.	Color of Wire	Signal Name
1	V	-
2	LG	-

Connector No.	E44
Connector Name	JOINT CONNECTOR-E01
Connector Color	WHITE

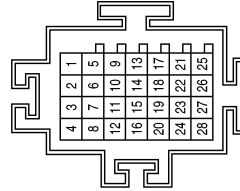

Terminal No.	Color of Wire	Signal Name
1	L	-
2	P	-

Terminal No.	Color of Wire	Signal Name
3	W	-
4	Y	-
5	L	-
6	P	-
7	W	-
8	Y	-
9	L	-
10	P	-
11	W	-
15	V	-
16	BR	-
19	V	-
20	BR	-
23	LG	-

AAB1A1440GB

A  
EC  
C  
D  
E  
F  
G  
H  
I  
J  
K  
L  
M  
N  
O  
P

# ENGINE CONTROL SYSTEM

< WIRING DIAGRAM >

[QR25DE]

Connector No.	E121
Connector Name	IPDM E/R (INTELLIGENT POWER DISTRIBUTION MODULE ENGINE ROOM)
Connector Color	RED



Terminal No.	Color of Wire	Signal Name
43	LG	O IGN LCS CABIN
44	R	O BAT ABS VALVE
46	W	O FUEL PUMP
47	B	POWER GROUND

Connector No.	E120
Connector Name	IPDM E/R (INTELLIGENT POWER DISTRIBUTION MODULE ENGINE ROOM)
Connector Color	GRAY

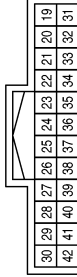

Terminal No.	Color of Wire	Signal Name
19	LG	O IGN ECM
22	P	CAN-L
24	L	CAN-H
31	B	2ND SIGNAL GROUND

Connector No.	E119
Connector Name	IPDM E/R (INTELLIGENT POWER DISTRIBUTION MODULE ENGINE ROOM)
Connector Color	GRAY

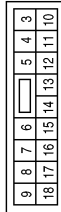

Terminal No.	Color of Wire	Signal Name
8	BG	O ACTUATOR4 CABIN (3FB4)
12	B	SIGNAL GROUND

Connector No.	F3
Connector Name	COOLING FAN MOTOR-1
Connector Color	GRAY



Terminal No.	Color of Wire	Signal Name
1	BG	-
2	BG	-
3	G	-
4	G	-

Terminal No.	Color of Wire	Signal Name
38J	BR	-
41J	G	-
50J	P	-
55J	W	-
56J	BG	-
57J	R	-
58J	V	-
59J	BR	-
60J	P	-
61J	L	-
97J	GR	-
98J	P	-
99J	W	-

Connector No.	E152
Connector Name	WIRE TO WIRE
Connector Color	WHITE

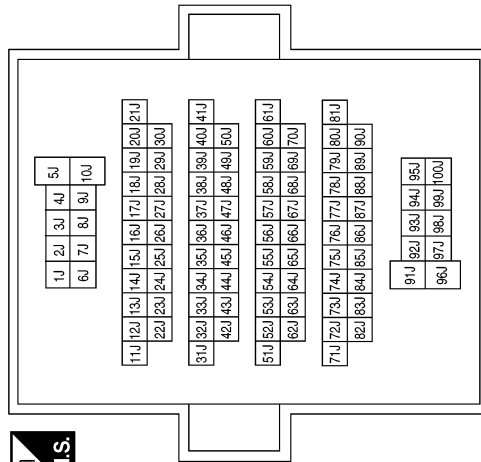

AAB1A1441GB



# ENGINE CONTROL SYSTEM

< WIRING DIAGRAM >

[QR25DE]

Connector No.	F9
Connector Name	KNOCK SENSOR
Connector Color	GRAY



Terminal No.	Color of Wire	Signal Name
1	W	-
2	SHIELD	-

Connector No.	F8
Connector Name	JOINT CONNECTOR-F01
Connector Color	BLACK

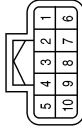

Terminal No.	Color of Wire	Signal Name
1	R	-
2	R	-
3	P	-
4	BG	-
5	BR	-
6	B	-
7	B	-
8	GR	-
9	B	-
10	B	-

Connector No.	F5
Connector Name	COOLING FAN MOTOR-2
Connector Color	GRAY



Terminal No.	Color of Wire	Signal Name
1	P	-
2	P	-
3	B	-
4	B	-

Connector No.	F12
Connector Name	FUEL INJECTOR NO. 2
Connector Color	GRAY



Terminal No.	Color of Wire	Signal Name
1	BG	-
2	G	-

Connector No.	F11
Connector Name	FUEL INJECTOR NO. 1
Connector Color	GRAY



Terminal No.	Color of Wire	Signal Name
1	LG	-
2	L	-

Connector No.	F10
Connector Name	REFRIGERANT PRESSURE SENSOR
Connector Color	BLACK



Terminal No.	Color of Wire	Signal Name
1	GR	-
2	P	-
3	BG	-

AABIA1442GB

A  
EC  
C  
D  
E  
F  
G  
H  
I  
J  
K  
L  
M  
N  
O  
P

# ENGINE CONTROL SYSTEM

< WIRING DIAGRAM >

[QR25DE]

Connector No.	F16
Connector Name	EVAP CANISTER PURGE VOLUME CONTROL SOLENOID VALVE
Connector Color	BLUE



Terminal No.	Color of Wire	Signal Name
1	BG	-
2	Y	-

Connector No.	F14
Connector Name	FUEL INJECTOR NO. 3
Connector Color	GRAY



Terminal No.	Color of Wire	Signal Name
1	W	-
2	P	-

Connector No.	F13
Connector Name	FUEL INJECTOR NO. 4
Connector Color	GRAY



Terminal No.	Color of Wire	Signal Name
1	SB	-
2	Y	-

Connector No.	F19
Connector Name	INTAKE MANIFOLD RUNNER CONTROL VALVE
Connector Color	BLACK



Terminal No.	Color of Wire	Signal Name
1	Y	-
2	G	-

Connector No.	F18
Connector Name	AIR FUEL RATIO (A/F) SENSOR 1
Connector Color	GRAY

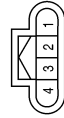

Terminal No.	Color of Wire	Signal Name
1	Y	-
2	G	-
3	P	-
4	BR	-

Connector No.	F17
Connector Name	CRANKSHAFT POSITION SENSOR
Connector Color	BLACK



Terminal No.	Color of Wire	Signal Name
1	L	-
2	BR	-
3	GR	-

AAB1A1443GB

# ENGINE CONTROL SYSTEM

< WIRING DIAGRAM >

[QR25DE]

Connector No.	F22
Connector Name	MASS AIR FLOW SENSOR
Connector Color	BLACK

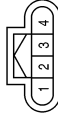

Terminal No.	Color of Wire	Signal Name
1	L	-
2	GR	-
3	BR	-
4	V	-

Connector No.	F21
Connector Name	HEATED OXYGEN SENSOR 2
Connector Color	BLACK

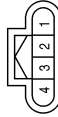

Terminal No.	Color of Wire	Signal Name
1	B	-
2	Y	-
3	V	-
4	L	-

Connector No.	F20
Connector Name	INTAKE MANIFOLD RUNNER CONTROL VALVE POSITION SENSOR
Connector Color	BLACK



Terminal No.	Color of Wire	Signal Name
1	V	-
2	L	-
3	LG	-

Connector No.	F25
Connector Name	INTAKE VALVE TIMING CONTROL SOLENOID VALVE
Connector Color	GRAY



Terminal No.	Color of Wire	Signal Name
1	G	-
2	L	-

Connector No.	F24
Connector Name	EXHAUST VALVE TIMING CONTROL SOLENOID VALVE
Connector Color	GRAY



Terminal No.	Color of Wire	Signal Name
1	L	-
2	BR	-

Connector No.	F23
Connector Name	INTAKE VALVE INTERMEDIATE LOCK TIMING CONTROL SOLENOID VALVE
Connector Color	GRAY



Terminal No.	Color of Wire	Signal Name
1	V	-
2	GR	-

AABIA1444GB

A  
EC  
C  
D  
E  
F  
G  
H  
I  
J  
K  
L  
M  
N  
O  
P

# ENGINE CONTROL SYSTEM

< WIRING DIAGRAM >

[QR25DE]

Connector No.	F41
Connector Name	IPDM E/R (INTELLIGENT POWER DISTRIBUTION MODULE ENGINE ROOM)
Connector Color	GRAY



Terminal No.	Color of Wire	Signal Name
83	G	O STARTER
84	LG	I BATT MOTOR FAN LO
85	P	O MOTOR FAN LO

Connector No.	F35
Connector Name	IPDM E/R (INTELLIGENT POWER DISTRIBUTION MODULE ENGINE ROOM)
Connector Color	WHITE

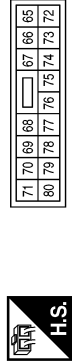

Terminal No.	Color of Wire	Signal Name
66	R	O ACTUATOR 1
67	V	LI ECM ACT5 DRIVER
70	BG	O IGN AT LPG
72	GR	O ACTUATOR5 (3FBA)
73	Y	O ACTUATOR1 2 (3FB)
75	BR	O ACTUATOR3 (3FB3)
76	P	LI FUEL PUMP DRIVER
78	L	O ACTUATOR2 (3FB2)

Connector No.	F33
Connector Name	WIRE TO WIRE
Connector Color	BROWN



Terminal No.	Color of Wire	Signal Name
1	B	-
2	BR	-
4	BG	-
5	LG	-
6	V	-
8	W	-
9	R	-
11	P	-
12	GR	-
13	Y	-
14	L	-

Connector No.	F45
Connector Name	EXHAUST VALVE TIMING CONTROL SENSOR
Connector Color	BLACK



Terminal No.	Color of Wire	Signal Name
1	Y	-
2	B	-
3	LG	-

Connector No.	F44
Connector Name	CAMSHAFT POSITION SENSOR
Connector Color	BLACK



Terminal No.	Color of Wire	Signal Name
1	B	-
2	R	-
3	W	-

Connector No.	F42
Connector Name	IPDM E/R (INTELLIGENT POWER DISTRIBUTION MODULE ENGINE ROOM)
Connector Color	BLACK

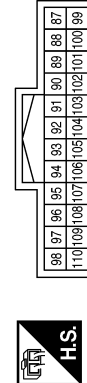

Terminal No.	Color of Wire	Signal Name
92	GR	LI NP SW
93	P	LI ECM DRIVER
106	BR	LO FAN RELAY2(PWM)
107	V	LO FAN RELAY 1

AAB1A1445GB

# ENGINE CONTROL SYSTEM

< WIRING DIAGRAM >

[QR25DE]

Connector No.	F48
Connector Name	IGNITION COIL NO.3 (WITH POWER TRANSISTOR)
Connector Color	GRAY



Terminal No.	Color of Wire	Signal Name
1	W	-
2	B	-
3	BG	-

Connector No.	F47
Connector Name	IGNITION COIL NO.1 (WITH POWER TRANSISTOR)
Connector Color	GRAY



Terminal No.	Color of Wire	Signal Name
1	Y	-
2	B	-
3	R	-

Connector No.	F46
Connector Name	IGNITION COIL NO.2 (WITH POWER TRANSISTOR)
Connector Color	GRAY



Terminal No.	Color of Wire	Signal Name
1	BR	-
2	GR	-
3	P	-

Connector No.	F50
Connector Name	ELECTRIC THROTTLE CONTROL ACTUATOR
Connector Color	BLACK



Terminal No.	Color of Wire	Signal Name
1	G	-
2	R	-
3	W	-
4	B	-
5	G	-
6	L	-

Connector No.	F49
Connector Name	IGNITION COIL NO.4 (WITH POWER TRANSISTOR)
Connector Color	GRAY



Terminal No.	Color of Wire	Signal Name
1	SB	-
2	B	-
3	BR	-

AABIA1446GB

A  
EC  
C  
D  
E  
F  
G  
H  
I  
J  
K  
L  
M  
N  
O  
P

# ENGINE CONTROL SYSTEM

< WIRING DIAGRAM >

[QR25DE]

Terminal No.	Color of Wire	Signal Name
39	P	ENGINE OIL PRESSURE SENSOR
40	W	SENSOR POWER SUPPLY
41	Y	A/F SENSOR 1
42	B	SENSOR GROUND
43	LG	EXHAUST VALVE TIMING CONTROL POSITION SENSOR
44	Y	SENSOR POWER SUPPLY
45	G	A/F SENSOR 1
46	-	-
47	-	-
48	-	-

Terminal No.	Color of Wire	Signal Name
17	BG	EVAP CANISTER PURGE VOLUME CONTROL SOLENOID VALVE
18	P	FUEL PUMP RELAY
19	-	-
20	-	-
21	V	THROTTLE CONTROL MOTOR RELAY
22	Y	HEATED OXYGEN SENSOR 2
23	B	SENSOR GROUND
24	-	-
25	P	ENGINE OIL TEMPERATURE SENSOR
26	BR	SENSOR GROUND
27	L	SENSOR GROUND
28	G	ENGINE COOLANT TEMPERATURE SENSOR
29	-	-
30	R	SENSOR GROUND
31	W	CAMSHAFT POSITION SENSOR (PHASE)
32	B	SENSOR POWER SUPPLY
33	V	INTAKE AIR TEMPERATURE SENSOR
34	GR	SENSOR GROUND
35	BR	MASS AIR FLOW SENSOR
36	L	SENSOR POWER SUPPLY
37	SHIELD	SHIELD
38	SB	SENSOR GROUND

Connector No.	F51
Connector Name	ECM
Connector Color	BLACK

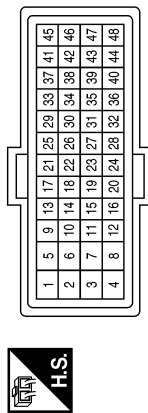

Terminal No.	Color of Wire	Signal Name
1	G	THROTTLE CONTROL MOTOR (CLOSE)
2	GR	THROTTLE CONTROL MOTOR POWER SUPPLY
3	L	THROTTLE CONTROL MOTOR (OPEN)
4	W	KNOCK SENSOR
5	-	-
6	-	-
7	-	-
8	SHIELD	SENSOR GROUND
9	Y	FUEL INJECTOR NO. 4
10	P	FUEL INJECTOR NO. 3
11	-	-
12	-	-
13	L	FUEL INJECTOR NO. 1
14	G	FUEL INJECTOR NO. 2
15	-	-
16	BR	ECM GROUND

AAB1A1214GB

# ENGINE CONTROL SYSTEM

< WIRING DIAGRAM >

[QR25DE]

Terminal No.	Color of Wire	Signal Name
89	P	ECM RELAY (SELF SHUT-OFF)
90	W	IGNITION SIGNAL NO. 3
91	SB	IGNITION SIGNAL NO. 4
92	LG	SENSOR GROUND
93	L	INTAKE VALVE TIMING CONTROL SOLENOID VALVE
94	BR	EXHAUST VALVE TIMING CONTROL SOLENOID VALVE
95	-	-
96	-	-

Terminal No.	Color of Wire	Signal Name
66	-	-
67	-	-
68	-	-
69	-	-
70	BR	SENSOR GROUND
71	GR	CRANKSHAFT POSITION SENSOR (POS)
72	L	SENSOR POWER SUPPLY
73	SHIELD	SHIELD
74	-	-
75	-	-
76	-	-
77	W	THROTTLE POSITION SENSOR 2
78	B	SENSOR GROUND
79	G	THROTTLE POSITION SENSOR 1
80	R	SENSOR POWER SUPPLY
81	R	POWER SUPPLY FOR ECM (BACKUP)
82	-	-
83	L	INTAKE MANIFOLD RUNNER CONTROL VALVE POSITION SENSOR
84	V	SENSOR POWER SUPPLY
85	G	LIN
86	Y	IGNITION SIGNAL NO. 1
87	BR	IGNITION SIGNAL NO. 2
88	-	-

Connector No.	F52
Connector Name	ECM
Connector Color	BROWN

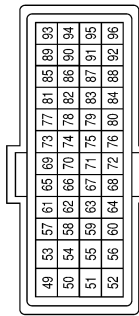

Terminal No.	Color of Wire	Signal Name
49	G	INTAKE MANIFOLD RUNNER CONTROL VALVE MOTOR (CLOSE)
50	V	INTAKE MANIFOLD RUNNER CONTROL VALVE MOTOR (POWER SUPPLY)
51	Y	INTAKE MANIFOLD RUNNER CONTROL VALVE MOTOR (OPEN)
52	B	ECM GROUND
53	P	A/F SENSOR 1 HEATER
54	V	HEATED OXYGEN SENSOR 2 HEATER
55	-	-
56	GR	INTAKE VALVE TIMING INTERMEDIATE LOCK CONTROL SOLENOID VALVE
57	-	-
58	-	-
59	-	-
60	-	-
61	-	-
62	-	-
63	-	-
64	-	-
65	-	-

AABIA1215GB

A  
EC  
C  
D  
E  
F  
G  
H  
I  
J  
K  
L  
M  
N  
O  
P

# ENGINE CONTROL SYSTEM

< WIRING DIAGRAM >

[QR25DE]

Connector No.	F68
Connector Name	ENGINE OIL TEMPERATURE SENSOR
Connector Color	GRAY



Terminal No.	Color of Wire	Signal Name
1	P	-
2	BR	-

Connector No.	F61
Connector Name	ENGINE COOLANT TEMPERATURE SENSOR
Connector Color	GRAY



Terminal No.	Color of Wire	Signal Name
1	G	-
2	L	-

Connector No.	F54
Connector Name	ENGINE OIL PRESSURE SENSOR
Connector Color	BLACK



Terminal No.	Color of Wire	Signal Name
1	SB	-
2	P	-
3	W	-

Connector No.	B108
Connector Name	EVAP CANISTER VENT CONTROL VALVE
Connector Color	BLACK



Terminal No.	Color of Wire	Signal Name
1	P	-
2	GR	-

Connector No.	B103
Connector Name	FUEL LEVEL SENSOR UNIT AND FUEL PUMP (MAIN)
Connector Color	GRAY



Terminal No.	Color of Wire	Signal Name
1	LA/R	-
3	LAV	-
4	LA/B	-
6	LA/GR	-

Connector No.	F78
Connector Name	TRANSMISSION RANGE SWITCH
Connector Color	BLACK



Terminal No.	Color of Wire	Signal Name
7	BG	-
10	GR	-

AAB1A1216GB



# ENGINE CONTROL SYSTEM

< WIRING DIAGRAM >

[QR25DE]

Terminal No.	Color of Wire	Signal Name
1G	LA/GR	-
7G	P	-
18G	GR	-
19G	R	-
20G	W	-
21G	P	-
78G	LA/R	-
79G	LA/V	-

Connector No.	B136
Connector Name	WIRE TO WIRE
Connector Color	WHITE

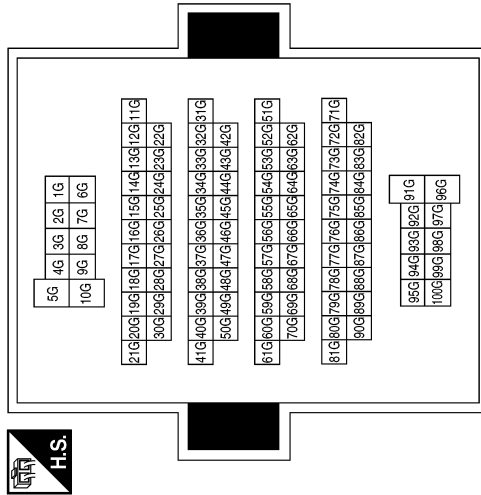

Connector No.	B111
Connector Name	EVAP CONTROL SYSTEM PRESSURE SENSOR
Connector Color	GRAY



Terminal No.	Color of Wire	Signal Name
1	W	-
2	P	-
3	R	-



Connector No.	H-3
Connector Name	COOLING FAN RELAY-3
Connector Color	BLACK

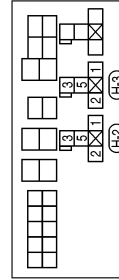

Terminal No.	Color of Wire	Signal Name
1	GR	-
2	BR	-
3	G	-
5	GR	-

Connector No.	H-2
Connector Name	COOLING FAN RELAY-2
Connector Color	BLACK

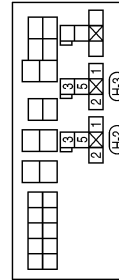

Terminal No.	Color of Wire	Signal Name
1	GR	-
2	V	-
3	G	-
5	P	-

AABIA1217GB

A  
EC  
C  
D  
E  
F  
G  
H  
I  
J  
K  
L  
M  
N  
O  
P

# DIAGNOSIS AND REPAIR WORKFLOW

< BASIC INSPECTION >

[QR25DE]

## BASIC INSPECTION

### DIAGNOSIS AND REPAIR WORKFLOW

#### Work Flow

INFOID:000000011277892

#### OVERALL SEQUENCE

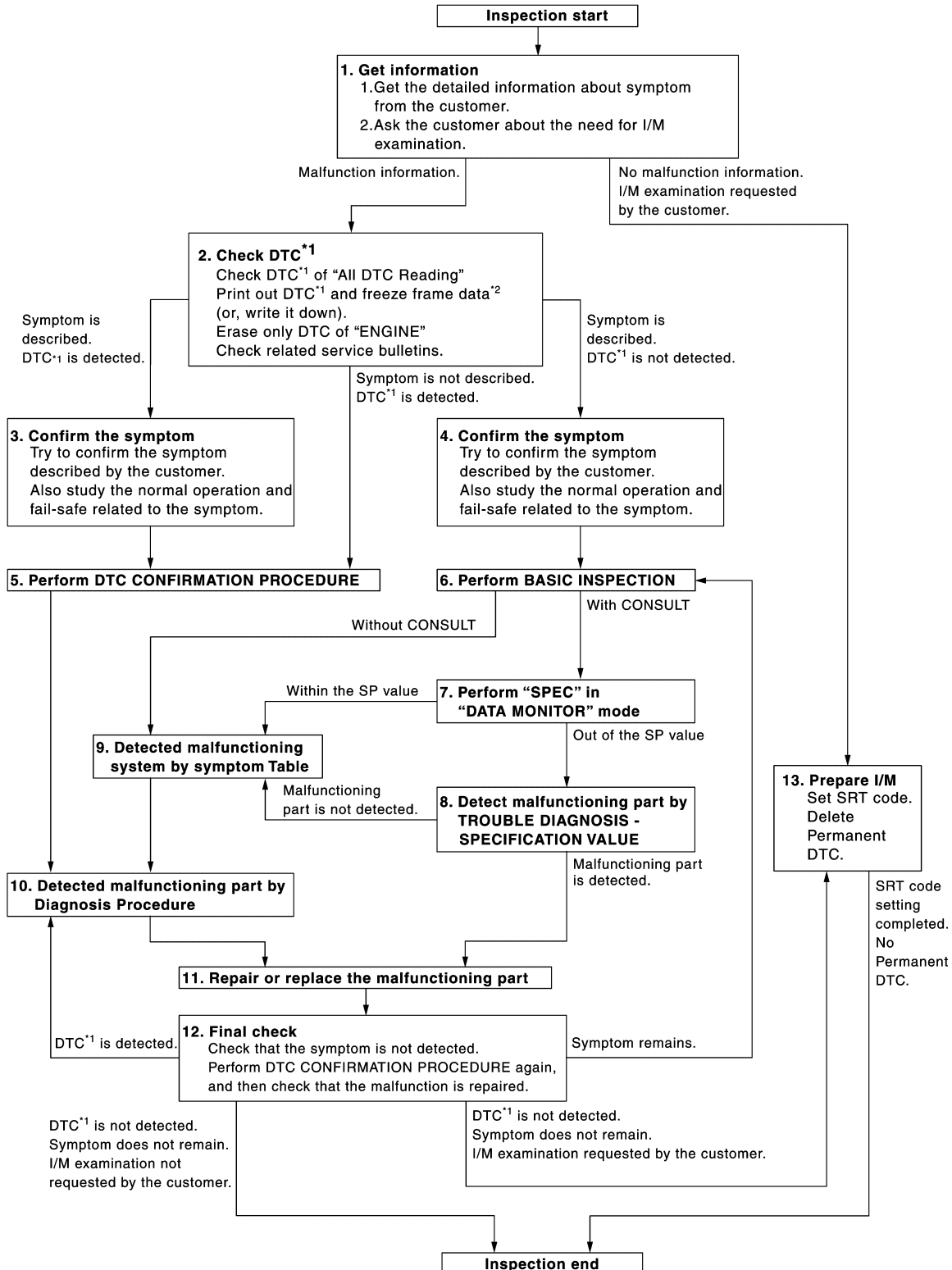

JSBIA0123GB

#### DETAILED FLOW

# DIAGNOSIS AND REPAIR WORKFLOW

[QR25DE]

< BASIC INSPECTION >

## 1. GET INFORMATION FOR SYMPTOM

1. Get the detailed information from the customer about the symptom (the condition and the environment when the incident/malfunction occurred) using the "Diagnostic Work Sheet". (Refer to [EC-133, "Diagnostic Work Sheet"](#).)
2. Ask if the customer requests I/M examination.

Malfunction information, obtained>>GO TO 2.

No malfunction information, but a request for I/M examination>>GO TO 13.

## 2. CHECK DTC

1. Check DTC.
2. Perform the following procedure if DTC is displayed.
  - Record DTC and freeze frame data. (Print them out with CONSULT or GST.)
  - Erase only DTC of "ENGINE".
  - Study the relationship between the cause detected by DTC and the symptom described by the customer. (Symptom Matrix Chart is useful. Refer to [EC-489, "Symptom Table"](#).)
3. Check related service bulletins for information.

Are any symptoms described and any DTCs detected?

Symptom is described, DTC is detected>>GO TO 3.

Symptom is described, DTC is not detected>>GO TO 4.

Symptom is not described, DTC is detected>>GO TO 5.

## 3. CONFIRM THE SYMPTOM

Try to confirm the symptom described by the customer (except MIL ON).

Also study the normal operation and fail-safe related to the symptom. Refer to [EC-495, "Description"](#) and [EC-92, "Fail Safe"](#).

Diagnosis Work Sheet is useful to verify the incident.

Verify relation between the symptom and the condition when the symptom is detected.

>> GO TO 5.

## 4. CONFIRM THE SYMPTOM

Try to confirm the symptom described by the customer.

Also study the normal operation and fail-safe related to the symptom. Refer to [EC-495, "Description"](#) and [EC-92, "Fail Safe"](#).

Diagnosis Work Sheet is useful to verify the incident.

Verify relation between the symptom and the condition when the symptom is detected.

>> GO TO 6.

## 5. PERFORM DTC CONFIRMATION PROCEDURE

Perform DTC CONFIRMATION PROCEDURE for the displayed DTC, and then check that DTC is detected again.

If two or more DTCs are detected, refer to [EC-95, "DTC Inspection Priority Chart"](#) and determine trouble diagnosis order.

### NOTE:

- Freeze frame data is useful if the DTC is not detected.
- Perform Component Function Check if DTC CONFIRMATION PROCEDURE is not included on Service Manual. This simplified check procedure is an effective alternative though DTC cannot be detected during this check.

If the result of Component Function Check is NG, it is the same as the detection of DTC by DTC CONFIRMATION PROCEDURE.

Is DTC detected?

YES >> GO TO 10.

NO >> Check according to [GI-44, "Intermittent Incident"](#).

## 6. PERFORM BASIC INSPECTION

Perform [EC-135, "Work Procedure"](#).

# DIAGNOSIS AND REPAIR WORKFLOW

[QR25DE]

< BASIC INSPECTION >

Do you have CONSULT?

YES >> GO TO 7.

NO >> GO TO 9.

## 7. PERFORM SPEC IN DATA MONITOR MODE

Ⓟ With CONSULT

Check that "MASS AIR FLOW SENSOR (Hz)", "B/FUEL SCHDL", and "A/F ALPHA-B1" are within the SP value using "SPEC" in "DATA MONITOR" mode with CONSULT. Refer to [EC-160, "Component Function Check"](#).

Is the measurement value within the SP value?

YES >> GO TO 9.

NO >> GO TO 8.

## 8. DETECT MALFUNCTIONING PART BY TROUBLE DIAGNOSIS - SPECIFICATION VALUE

Detect malfunctioning part according to [EC-161, "Diagnosis Procedure"](#).

Is a malfunctioning part detected?

YES >> GO TO 11.

NO >> GO TO 9.

## 9. DETECT MALFUNCTIONING SYSTEM BY SYMPTOM TABLE

Detect malfunctioning system according to [EC-489, "Symptom Table"](#) based on the confirmed symptom in step 4, and determine the trouble diagnosis order based on possible causes and symptoms.

>> GO TO 10.

## 10. DETECT MALFUNCTIONING PART BY DIAGNOSIS PROCEDURE

Inspect according to Diagnosis Procedure of the system.

### NOTE:

The Diagnosis Procedure in EC section described based on open circuit inspection. A short circuit inspection is also required for the circuit check in the Diagnosis Procedure. For details, refer to [GI-46, "Circuit Inspection"](#).

Is a malfunctioning part detected?

YES >> GO TO 11.

NO >> Monitor input data from related sensors or check voltage of related ECM terminals using CONSULT. Refer to [EC-80, "Reference Value"](#).

## 11. REPAIR OR REPLACE THE MALFUNCTIONING PART

1. Repair or replace the malfunctioning part.
2. Reconnect parts or connectors disconnected during Diagnosis Procedure again after repair and replacement.
3. Check DTC. If DTC is displayed, erase it.

>> GO TO 12.

## 12. FINAL CHECK

When DTC was detected in step 2, perform DTC CONFIRMATION PROCEDURE or Component Function Check again, and then check that the malfunction have been completely repaired.

When symptom was described from the customer, refer to confirmed symptom in step 3 or 4, and check that the symptom is not detected.

Is DTC detected and does symptom remain?

YES-1 >> DTC is detected: GO TO 10.

YES-2 >> Symptom remains: GO TO 6.

NO-1 >> No request for I/M examination from the customer: Before returning the vehicle to the customer, always erase unnecessary DTC in ECM. If the completion of SRT is needed, drive vehicle under the specific driving pattern. Refer to [EC-149, "SRT Set Driving Pattern"](#).

NO-2 >> I/M examination, requested from the customer: GO TO 13.

## 13. PREPARE FOR I/M EXAMINATION

# DIAGNOSIS AND REPAIR WORKFLOW

< BASIC INSPECTION >

[QR25DE]

1. Set SRT codes. Refer to [EC-148, "Description"](#).
2. Erase permanent DTCs. Refer to [EC-154, "Description"](#).

A

>> INSPECTION END

## Diagnostic Work Sheet

INFOID:000000011277893

EC

### DESCRIPTION

There are many operating conditions that lead to the malfunction of engine components. A good grasp of such conditions can make troubleshooting faster and more accurate.

In general, each customer feels differently about symptoms. It is important to fully understand the symptoms or conditions for a customer complaint.

Utilize a diagnostic worksheet like the WORKSHEET SAMPLE below in order to organize all the information for troubleshooting.

Some conditions may cause the MIL to illuminate or blink, and DTC to be detected. Examples:

- Vehicle ran out of fuel, which caused the engine to misfire.
- Fuel filler cap was left off or incorrectly screwed on, allowing fuel to evaporate into the atmosphere.

#### KEY POINTS

**WHAT** ..... Vehicle & engine model  
**WHEN** ..... Date, Frequencies  
**WHERE**..... Road conditions  
**HOW** ..... Operating conditions,  
Weather conditions,  
Symptoms

SEP907L

C

D

E

F

G

H

I

J

K

L

M

N

O

P



BASIC INSPECTION

Work Procedure

INFOID:000000011277894

1.INSPECTION START

1. Check service records for any recent repairs that may indicate a related malfunction, or a current need for scheduled maintenance.
2. Open engine hood and check the following:
  - Harness connectors for improper connections
  - Wiring harness for improper connections, pinches and cut
  - Vacuum hoses for splits, kinks and improper connections
  - Hoses and ducts for leaks
  - Air cleaner clogging
  - Gasket
3. Confirm that electrical or mechanical loads are not applied.
  - Headlamp switch is OFF.
  - Air conditioner switch is OFF.
  - Rear window defogger switch is OFF.
  - Steering wheel is in the straight-ahead position, etc.
4. Start engine and warm it up until engine coolant temperature indicator points the middle of gauge. Ensure engine stays below 1,000 rpm.

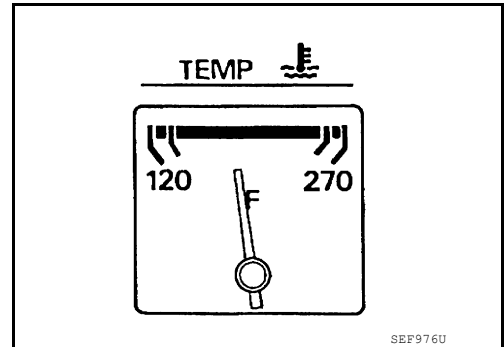
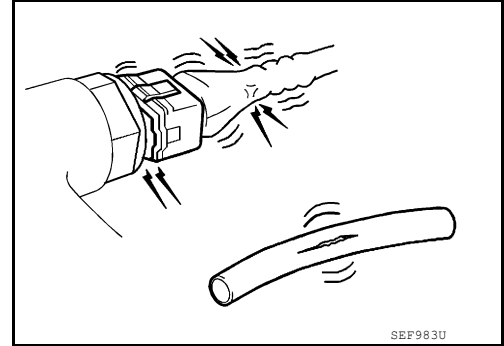

5. Run engine at about 2,000 rpm for about 2 minutes under no load.
6. Make sure that no DTC is displayed with CONSULT or GST.

Is any DTC detected?

- YES >> GO TO 2.
- NO >> GO TO 3.

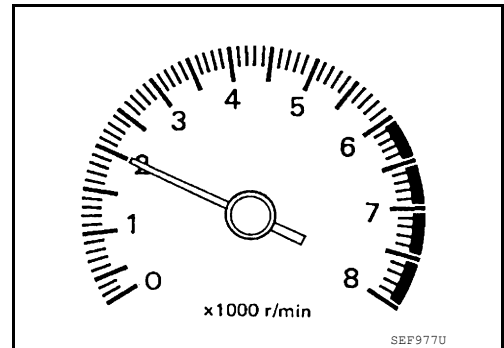

2.REPAIR OR REPLACE

Repair or replace components as necessary according to corresponding Diagnostic Procedure.

>> GO TO 3.

3.CHECK TARGET IDLE SPEED

1. Run engine at about 2,000 rpm for about 2 minutes under no load.

A  
EC  
C  
D  
E  
F  
G  
H  
I  
J  
K  
L  
M  
N  
O  
P

# BASIC INSPECTION

[QR25DE]

## < BASIC INSPECTION >

- Rev engine (2,000 to 3,000 rpm) two or three times under no load, then run engine at idle speed for about 1 minute.
- Check idle speed.  
For procedure, refer to [EC-496, "Inspection"](#).  
For specification, refer to [EC-503, "Idle Speed"](#).

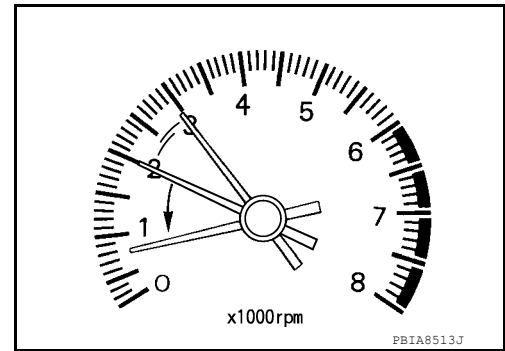

### Is the inspection result normal?

- YES >> GO TO 10.  
NO >> GO TO 4.

## 4.PERFORM ACCELERATOR PEDAL RELEASED POSITION LEARNING

- Stop engine.
- Perform [EC-142, "Work Procedure"](#).

>> GO TO 5.

## 5.PERFORM THROTTLE VALVE CLOSED POSITION LEARNING

Perform [EC-143, "Work Procedure"](#).

>> GO TO 6.

## 6.PERFORM IDLE AIR VOLUME LEARNING

Perform [EC-144, "Work Procedure"](#).

### Is Idle Air Volume Learning carried out successfully?

- YES >> GO TO 7.  
NO >> Follow the instruction of Idle Air Volume Learning. Then GO TO 4.

## 7.CHECK TARGET IDLE SPEED AGAIN

- Start engine and warm it up to normal operating temperature.
- Check idle speed.  
For procedure, refer to [EC-496, "Inspection"](#).  
For specification, refer to [EC-503, "Idle Speed"](#).

### Is the inspection result normal?

- YES >> GO TO 10.  
NO >> GO TO 8.

## 8.DETECT MALFUNCTIONING PART

Check the Following.

- Check camshaft position sensor (PHASE) and circuit. Refer to [EC-301, "DTC Description"](#).
- Check crankshaft position sensor (POS) and circuit. Refer to [EC-298, "DTC Description"](#).

### Is the inspection result normal?

- YES >> GO TO 9.  
NO >> Repair or replace. Then GO TO 4

## 9.CHECK ECM FUNCTION

- Substitute another known-good ECM to check ECM function. (ECM may be the cause of an incident, but this is a rare case.)
- Perform initialization of NVIS (NATS) system and registration of all NVIS (NATS) ignition key IDs. Refer to [SEC-66, "ECM : Work Procedure"](#) (With intelligent key system) or [SEC-159, "ECM RE-COMMUNICATING FUNCTION : Special Repair Requirement"](#) (Without intelligent key system).

>> GO TO 4.

## 10.CHECK IGNITION TIMING

- Run engine at idle.



# BASIC INSPECTION

[QR25DE]

## < BASIC INSPECTION >

2. Check ignition timing with a timing light.  
For procedure, refer to [EC-497, "Inspection"](#)  
For specification, refer to [EC-503, "Ignition Timing"](#).

① Timing indicator

Is the inspection result normal?

- YES >> INSPECTION END.  
NO >> GO TO 11.

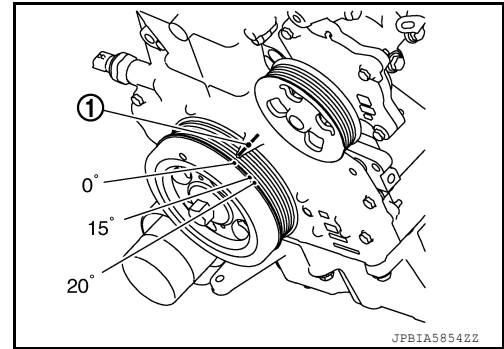

## 11. PERFORM ACCELERATOR PEDAL RELEASED POSITION LEARNING

1. Stop engine.
2. Perform [EC-142, "Work Procedure"](#).

>> GO TO 12.

## 12. PERFORM THROTTLE VALVE CLOSED POSITION LEARNING

Perform [EC-143, "Work Procedure"](#).

>> GO TO 13.

## 13. PERFORM IDLE AIR VOLUME LEARNING

Perform [EC-144, "Work Procedure"](#).

Is Idle Air Volume Learning carried out successfully?

- YES >> GO TO 14.  
NO >> Follow the instruction of Idle Air Volume Learning. Then GO TO 4.

## 14. CHECK TARGET IDLE SPEED AGAIN

1. Start engine and warm it up to normal operating temperature.
2. Check idle speed.  
For procedure, refer to [EC-496, "Inspection"](#).  
For specification, refer to [EC-503, "Idle Speed"](#).

Is the inspection result normal?

- YES >> GO TO 15.  
NO >> GO TO 17.

## 15. CHECK IGNITION TIMING AGAIN

1. Run engine at idle.
2. Check ignition timing with a timing light.  
For procedure, refer to [EC-497, "Inspection"](#).  
For specification, refer to [EC-503, "Ignition Timing"](#).

① Timing indicator

Is the inspection result normal?

- YES >> INSPECTION END.  
NO >> GO TO 16.

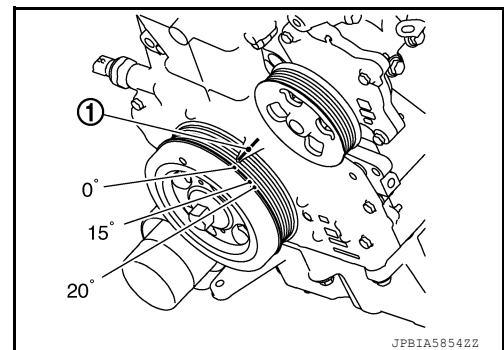

## 16. CHECK TIMING CHAIN INSTALLATION

Check timing chain installation. Refer to [EM-50, "Removal and Installation"](#).

Is the inspection result normal?

- YES >> GO TO 17.  
NO >> Repair the timing chain installation. Then GO TO 4.

< BASIC INSPECTION >

---

## 17. DETECT MALFUNCTIONING PART

---

Check the following.

- Check camshaft position sensor (PHASE) and circuit. Refer to [EC-301, "DTC Description"](#).
- Check crankshaft position sensor (POS) and circuit. Refer to [EC-298, "DTC Description"](#).

Is the inspection result normal?

YES >> GO TO 18.

NO >> Repair or replace. Then GO TO 4

---

## 18. CHECK ECM FUNCTION

---

1. Substitute another known-good ECM to check ECM function. (ECM may be the cause of an incident, but this is a rare case.)
2. Perform initialization of NVIS (NATS) system and registration of all NVIS (NATS) ignition key IDs. Refer to [SEC-66, "ECM : Work Procedure"](#) (With intelligent key system) or [SEC-159, "ECM RE-COMMUNICATING FUNCTION : Special Repair Requirement"](#) (Without intelligent key system).

>> GO TO 4.

# ADDITIONAL SERVICE WHEN REPLACING ECM

< BASIC INSPECTION >

[QR25DE]

## ADDITIONAL SERVICE WHEN REPLACING ECM

### Description

INFOID:0000000011277895

When replacing ECM, the following procedure must be performed. (For details, refer to [EC-139. "Work Procedure"](#).)

### PROGRAMMING OPERATION

#### NOTE:

After replacing with a blank ECM, programming is required to write ECM information. Be sure to follow the procedure to perform the programming.

### Work Procedure

INFOID:0000000011277896

#### 1. SAVE ECM DATA

##### Ⓜ With CONSULT

1. Turn ignition switch OFF.
2. Reconnect all harness connectors disconnected.
3. Turn ignition switch ON.
4. Select "SAVING DATA FOR REPLC CPU" in "WORK SUPPORT" mode of "ENGINE" using CONSULT.
5. Follow the instruction of CONSULT display.

#### NOTE:

- Necessary data in ECM is copied and saved to CONSULT.
- Go to Step 2 regardless of with or without success in saving data.

>> GO TO 2.

#### 2. CHECK ECM PART NUMBER

Check ECM part number to see whether it is blank ECM or not.

#### NOTE:

- Part number of blank ECM is 23703 - xxxxxx.
- Check part number when ordering ECM or the one included in the label on the container box.

Is the ECM a blank ECM?

- YES >> GO TO 3.  
NO >> GO TO 5.

#### 3. SAVE ECM PART NUMBER

Read out the part number from the old ECM and save the number, following the programming instructions. Refer to CONSULT Operation Manual.

#### NOTE:

- The ECM part number is saved in CONSULT.
- Even when ECM part number is not saved in CONSULT, go to 4.

>> GO TO 4.

#### 4. PERFORM ECM PROGRAMMING

After replacing ECM, perform the ECM programming. Refer to CONSULT Operation Manual.

#### NOTE:

- Refer to [EC-502. "Removal and Installation"](#) for replacement of ECM.
- During programming, maintain the following conditions:
  - Ignition switch: ON
  - Electric load: OFF
  - Brake pedal: Not depressed
  - Battery voltage: 12 – 13.5 V (Be sure to check the value of battery voltage by selecting "BATTERY VOLT" in "Data monitor" of CONSULT.)

>> GO TO 6.

#### 5. REPLACE ECM

## ADDITIONAL SERVICE WHEN REPLACING ECM

[QR25DE]

< BASIC INSPECTION >

Replace ECM. Refer to [EC-502. "Removal and Installation"](#).

>> GO TO 6.

### 6. PERFORM INITIALIZATION OF IVIS (NATS) SYSTEM AND REGISTRATION OF ALL IVIS (NATS) IGNITION KEY IDS

Refer to [SEC-63. "Work Flow"](#) (with intelligent key system) or [SEC-156. "Work Flow"](#) (without intelligent key system).

>> GO TO 7.

### 7. CHECK ECM DATA STATUS

Check if the data is successfully copied from the ECM at Step 1 (before replacement) and saved in CONSULT.  
Is the data saved successfully?

YES >> GO TO 8.  
NO >> GO TO 9.

### 8. WRITE ECM DATA

 With CONSULT

1. Select "WRITING DATA FOR REPLC CPU" in "WORK SUPPORT" mode of "ENGINE" using CONSULT.
2. Follow the instruction of CONSULT display.

**NOTE:**

The data saved by "SAVING DATA FOR REPLC CPU" is written to ECM.

>> GO TO 10.

### 9. PERFORM VIN REGISTRATION

Refer to [EC-141. "Work Procedure"](#).

>> GO TO 10.

### 10. PERFORM ACCELERATOR PEDAL RELEASED POSITION LEARNING

Perform Accelerator Pedal Released Position Learning. Refer to [EC-142. "Work Procedure"](#).

>> GO TO 11.

### 11. PERFORM THROTTLE VALVE CLOSED POSITION LEARNING

Perform Throttle Valve Closed Position Learning. Refer to [EC-143. "Work Procedure"](#).

>> GO TO 12.

### 12. PERFORM IDLE AIR VOLUME LEARNING

Perform Idle Air Volume Learning. Refer to [EC-144. "Work Procedure"](#).

>> END

# VIN REGISTRATION

< BASIC INSPECTION >

[QR25DE]

## VIN REGISTRATION

### Description

INFOID:0000000011277897

VIN Registration is an operation to registering VIN in ECM. It must be performed each time ECM is replaced.

**NOTE:**

Accurate VIN which is registered in ECM may be required for Inspection & Maintenance (I/M).

### Work Procedure

INFOID:0000000011277898

#### 1. CHECK VIN

Check the VIN of the vehicle and note it. Refer to [GI-34. "Identification Number"](#).

>> GO TO 2.

#### 2. PERFORM VIN REGISTRATION

 With CONSULT

1. Turn ignition switch ON and engine stopped.
2. Select "VIN REGISTRATION" in "WORK SUPPORT" mode of "ENGINE" using CONSULT.
3. Follow the instruction of CONSULT display.

>> END

A  
EC  
C  
D  
E  
F  
G  
H  
I  
J  
K  
L  
M  
N  
O  
P

# ACCELERATOR PEDAL RELEASED POSITION LEARNING

< BASIC INSPECTION >

[QR25DE]

---

## ACCELERATOR PEDAL RELEASED POSITION LEARNING

### Description

INFOID:000000011277899

Accelerator Pedal Released Position Learning is a function of ECM to learn the fully released position of the accelerator pedal by monitoring the accelerator pedal position sensor output signal. It must be performed each time harness connector of accelerator pedal position sensor or ECM is disconnected.

### Work Procedure

INFOID:000000011277900

#### 1. START

---

1. Make sure that accelerator pedal is fully released.
2. Turn ignition switch ON and wait at least 2 seconds.
3. Turn ignition switch OFF and wait at least 10 seconds.
4. Turn ignition switch ON and wait at least 2 seconds.
5. Turn ignition switch OFF and wait at least 10 seconds.

>> END

# THROTTLE VALVE CLOSED POSITION LEARNING

< BASIC INSPECTION >

[QR25DE]

## THROTTLE VALVE CLOSED POSITION LEARNING

### Description

INFOID:0000000011277901

Throttle Valve Closed Position Learning is a function of ECM to learn the fully closed position of the throttle valve by monitoring the throttle position sensor output signal. It must be performed each time the harness connector of the electric throttle control actuator or ECM is disconnected or electric throttle control actuator inside is cleaned.

### Work Procedure

INFOID:0000000011277902

#### 1. START

##### Ⓜ With CONSULT

1. Turn ignition switch ON.
2. Select "CLSD THL POS LEARN" in "WORK SUPPORT" mode of "ENGINE" using CONSULT.
3. Follow the instructions on the CONSULT display.
4. Turn ignition switch OFF and wait at least 10 seconds.  
Check that throttle valve moves during the above 10 seconds by confirming the operating sound.

##### ⓧ Without CONSULT

1. Start the engine.  
**NOTE:**  
Engine coolant temperature is 25°C (77°F) or less before engine starts.
2. Warm up the engine.  
**NOTE:**  
Raise engine coolant temperature until it reaches 65°C (149°F) or more.
3. Turn ignition switch OFF and wait at least 10 seconds.  
Check that throttle valve moves during the above 10 seconds by confirming the operating sound.

>> END

## IDLE AIR VOLUME LEARNING

### Description

INFOID:000000011277903

Idle Air Volume Learning is a function of ECM to learn the idle air volume that keeps each engine idle speed within the specific range. It must be performed under any of the following conditions:

- Each time electric throttle control actuator or ECM is replaced.
- Idle speed or ignition timing is out of specification.

### Work Procedure

INFOID:000000011277904

#### 1. PRECONDITIONING

Make sure that all of the following conditions are satisfied.

Learning will be cancelled if any of the following conditions are missed for even a moment.

- Battery voltage: More than 12.9 V (At idle)
- Engine coolant temperature: 70 - 100°C (158 - 212°F)
- Selector lever : P or N
- Electric load switch: OFF  
(Air conditioner, headlamp, rear window defogger)

**On vehicles equipped with daytime running light systems, set lighting switch to the 1st position to light only small lamps.**

- Steering wheel: Neutral (Straight-ahead position)
- Vehicle speed: Stopped
- Transmission: Warmed-up

-  With CONSULT

Drive vehicle until "ATF TENP SEN" in "DATA MONITOR" mode of "CVT" system indicates less than 0.9 V.

-  Without CONSULT

Drive vehicle for 10 minutes.

#### Do you have CONSULT?

- YES >> GO TO 2.
- NO >> GO TO 3.

#### 2. IDLE AIR VOLUME LEARNING

With CONSULT

1. Perform Accelerator Pedal Released Position Learning. Refer to [EC-142, "Work Procedure"](#).
2. Perform Throttle Valve Closed Position Learning. Refer to [EC-143, "Work Procedure"](#).
3. Start engine and warm it up to normal operating temperature.
4. Select "IDLE AIR VOL LEARN" in "WORK SUPPORT" mode of "ENGINE".
5. Touch "START" and wait 20 seconds.

#### Is "CMPLT" displayed on CONSULT screen?

- YES >> GO TO 4.
- NO >> GO TO 5.

#### 3. IDLE AIR VOLUME LEARNING

Without CONSULT

**NOTE:**

- **It is better to count the time accurately with a clock.**
- **It is impossible to switch the diagnostic mode when an accelerator pedal position sensor circuit has a malfunction.**

1. Perform Accelerator Pedal Released Position Learning. Refer to [EC-142, "Work Procedure"](#).
2. Perform Throttle Valve Closed Position Learning. Refer to [EC-143, "Work Procedure"](#).
3. Start engine and warm it up to normal operating temperature.
4. Turn ignition switch OFF and wait at least 10 seconds.
5. Confirm that accelerator pedal is fully released, turn ignition switch ON and wait 3 seconds.
6. Repeat the following procedure quickly five times within 5 seconds.
  - Fully depress the accelerator pedal.
  - Fully release the accelerator pedal.
7. Wait 7 seconds, fully depress the accelerator pedal and keep it for approx. 20 seconds until the MIL stops blinking and turned ON.



# IDLE AIR VOLUME LEARNING

[QR25DE]

< BASIC INSPECTION >

8. Fully release the accelerator pedal within 3 seconds after the MIL turned ON.
9. Start engine and let it idle.
10. Wait 20 seconds.

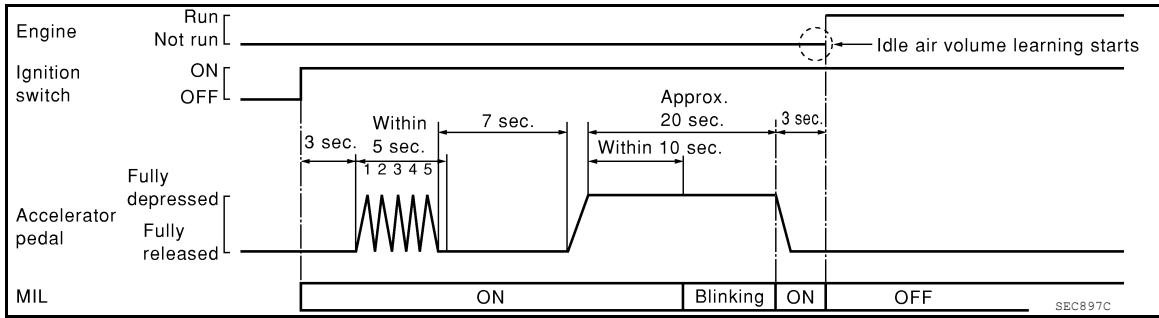

>> GO TO 4

## 4. CHECK IDLE SPEED AND IGNITION TIMING

Rev up the engine two or three times and make sure that idle speed and ignition timing are within the specifications. For specification, refer to [EC-503. "Idle Speed"](#) and [EC-503. "Ignition Timing"](#).

Is the inspection result normal?

- YES >> INSPECTION END
- NO >> GO TO 5.

## 5. DETECT MALFUNCTIONING PART

Check the following

- Check that throttle valve is fully closed.
- Check PCV valve operation.
- Check that downstream of throttle valve is free from air leakage.

Is the inspection result normal?

- YES >> GO TO 6.
- NO >> Repair or replace malfunctioning part.

## 6. DETECT MALFUNCTIONING PART

Engine component parts and their installation condition are questionable. Check and eliminate the cause of the incident.

It is useful to perform "TROUBLE DIAGNOSIS - SPECIFICATION VALUE". Refer to [EC-160. "Description"](#).

If any of the following conditions occur after the engine has started, eliminate the cause of the incident and perform Idle Air Volume Learning all over again:

- Engine stalls.
- Erroneous idle.

>> INSPECTION END

# MIXTURE RATIO SELF-LEARNING VALUE CLEAR

< BASIC INSPECTION >

[QR25DE]

---

## MIXTURE RATIO SELF-LEARNING VALUE CLEAR

### Description

INFOID:000000011277905

This describes how to erase the mixture ratio self-learning value. For the actual procedure, follow the instructions in "Diagnosis Procedure".

### Work Procedure

INFOID:000000011277906

#### 1. START

---

##### With CONSULT

1. Start engine and warm it up to normal operating temperature.
2. Select "SELF-LEARNING CONT" in "WORK SUPPORT" mode of "ENGINE" using CONSULT.
3. Clear mixture ratio self-learning value by touching "CLEAR".

##### With GST

1. Start engine and warm it up to normal operating temperature.
2. Turn ignition switch OFF.
3. Disconnect mass air flow sensor harness connector.
4. Restart engine and let it idle for at least 5 seconds.
5. Stop engine and reconnect mass air flow sensor harness connector.
6. Select Service \$03 with GST. Make sure DTC P0102 is detected.
7. Select Service \$04 with GST to erase the DTC P0102.

>> END

## FUEL PRESSURE

### Work Procedure

INFOID:000000011277907

### FUEL PRESSURE RELEASE

#### 1. FUEL PRESSURE RELEASE

##### ☐ With CONSULT

1. Turn ignition switch ON.
2. Perform "FUEL PRESSURE RELEASE" in "WORK SUPPORT" mode of "ENGINE" using CONSULT.
3. Start engine.
4. After engine stalls, crank it two or three times to release all fuel pressure.
5. Turn ignition switch OFF.

##### ☒ Without CONSULT

1. Remove fuel pump fuse located in IPDM E/R. For the fuse number, refer to [EC-108, "Wiring Diagram"](#). For the fuse arrangement, refer to [PG-68, "IPDM E/R Terminal Arrangement"](#).
2. Start engine.
3. After engine stalls, crank it two or three times to release all fuel pressure.
4. Turn ignition switch OFF.
5. Reinstall fuel pump fuse after servicing fuel system.

>> END

### FUEL PRESSURE CHECK

#### CAUTION:

Before disconnecting fuel line, release fuel pressure from fuel line to eliminate danger.

#### NOTE:

- Prepare pans or saucers under the disconnected fuel line because the fuel may spill out. The fuel pressure cannot be completely released because this models do not have fuel return system.
- Use Fuel Pressure Gauge Kit [SST: (J-44321)] to check fuel pressure.

#### 1. FUEL PRESSURE CHECK

1. Release fuel pressure to zero.
2. Connect fuel tube adapter [SST:KV10120000] (B) to quick connector.

A : Fuel pressure gauge

C : Fuel feed hose

⇐ : Vehicle front

3. Turn ignition switch ON and check for fuel leakage.
4. Start engine and check for fuel leakage.
5. Read the indication of fuel pressure gauge.

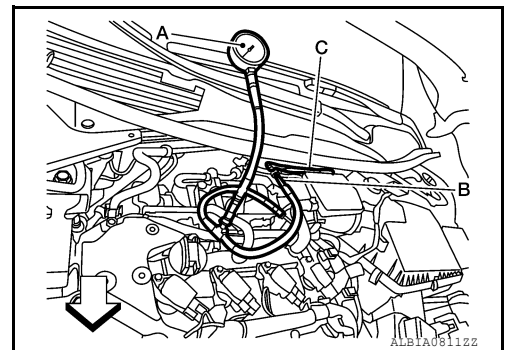

**At idling : Approximately 350 kPa (3.57 kg/cm<sup>2</sup>, 51 psi)**

Is the inspection result normal?

YES >> INSPECTION END

NO >> GO TO 2.

#### 2. CHECK FUEL HOSES AND FUEL TUBES

Check fuel hoses and fuel tubes for clogging.

Is the inspection result normal?

YES >> Replace "fuel filter and fuel pump assembly". Refer to [FL-5, "Removal and Installation"](#).

NO >> Repair or replace error-detected parts.

# HOW TO SET SRT CODE

< BASIC INSPECTION >

[QR25DE]

## HOW TO SET SRT CODE

### Description

INFOID:000000011277908

### OUTLINE

In order to set all SRTs, the self-diagnoses as in the “SRT ITEM” table must have been performed at least once. Each diagnosis may require actual driving for a long period of time under various conditions.

### SRT ITEM

The table below shows required self-diagnostic items to set the SRT to “CMPLT”.

SRT item* <sup>1</sup> (CONSULT indication)	Performance Priority* <sup>2</sup>	Required self-diagnostic items to set the SRT to “CMPLT”	Corresponding DTC No.
CATALYST	1	Three way catalyst function	P0420
EVAP SYSTEM	1	EVAP control system purge flow monitoring	P0441
	1	EVAP control system	P0456
HO2S	1	Air fuel ratio (A/F) sensor 1	P014C, P014D, P015A, P015B
		Heated oxygen sensor 2	P0137
		Heated oxygen sensor 2	P0138
		Heated oxygen sensor 2	P0139
EGR/VVT SYSTEM	2	Intake valve timing control function	P0011, P052A, P052B

\*1: Though displayed on the CONSULT screen, “HO2S HTR” is not SRT item.

\*2: If completion of several SRTs is required, perform driving patterns (DTC confirmation procedure), one by one based on the priority for models with CONSULT.

### SRT SERVICE PROCEDURE

# HOW TO SET SRT CODE

< BASIC INSPECTION >

[QR25DE]

If a vehicle has failed the state emissions inspection due to one or more SRT items indicating "INCMP", review the flowchart diagnostic sequence, referring to the following flowchart.

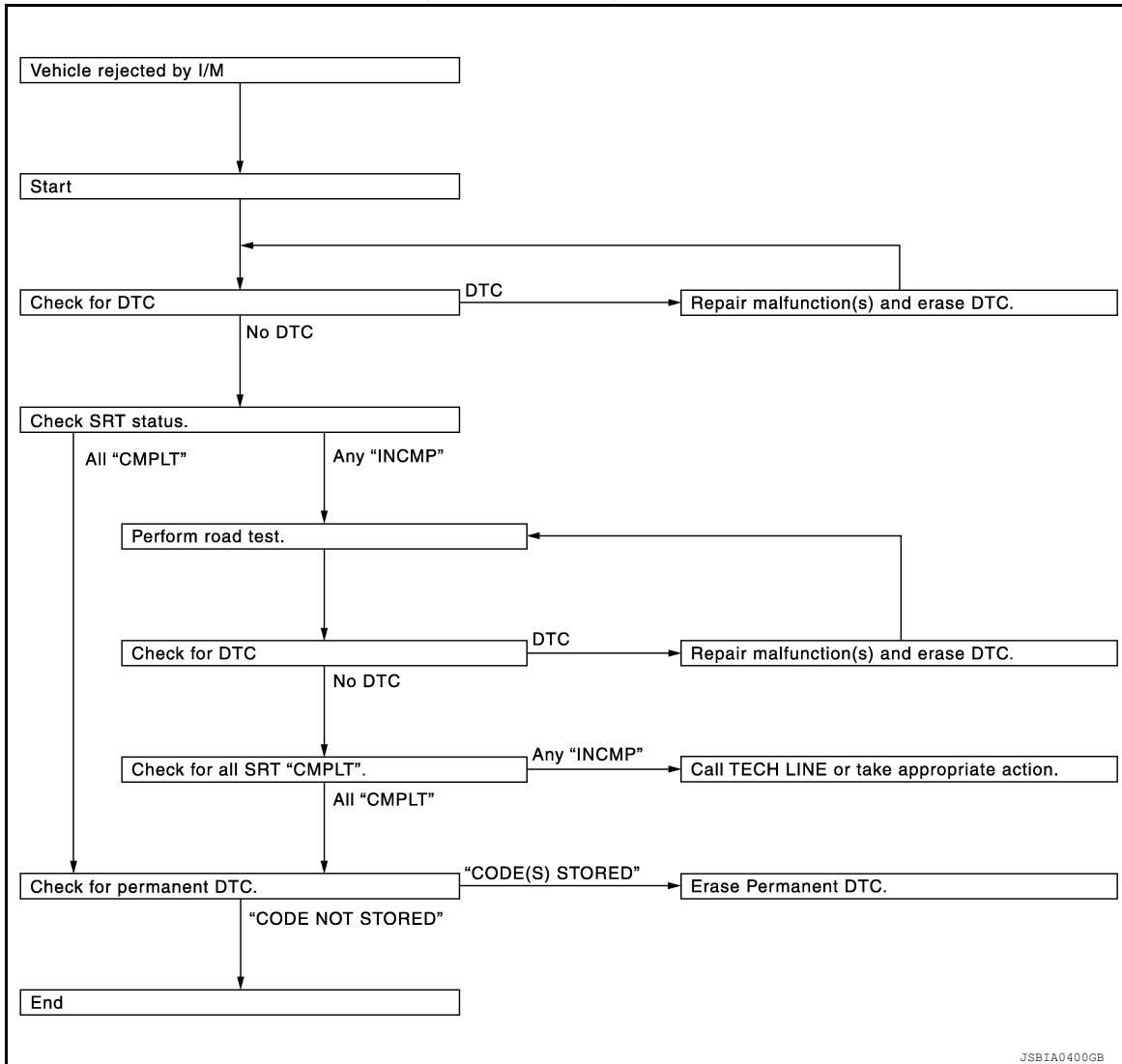

## SRT Set Driving Pattern

INFOID:000000011277909

**CAUTION:**

# HOW TO SET SRT CODE

< BASIC INSPECTION >

[QR25DE]

Always drive the vehicle in safe manner according to traffic conditions and obey all traffic laws.

**Note: Always drive vehicle in safe manner according to traffic conditions and obey all traffic laws. Refer to next page for more information and explanation of chart.**

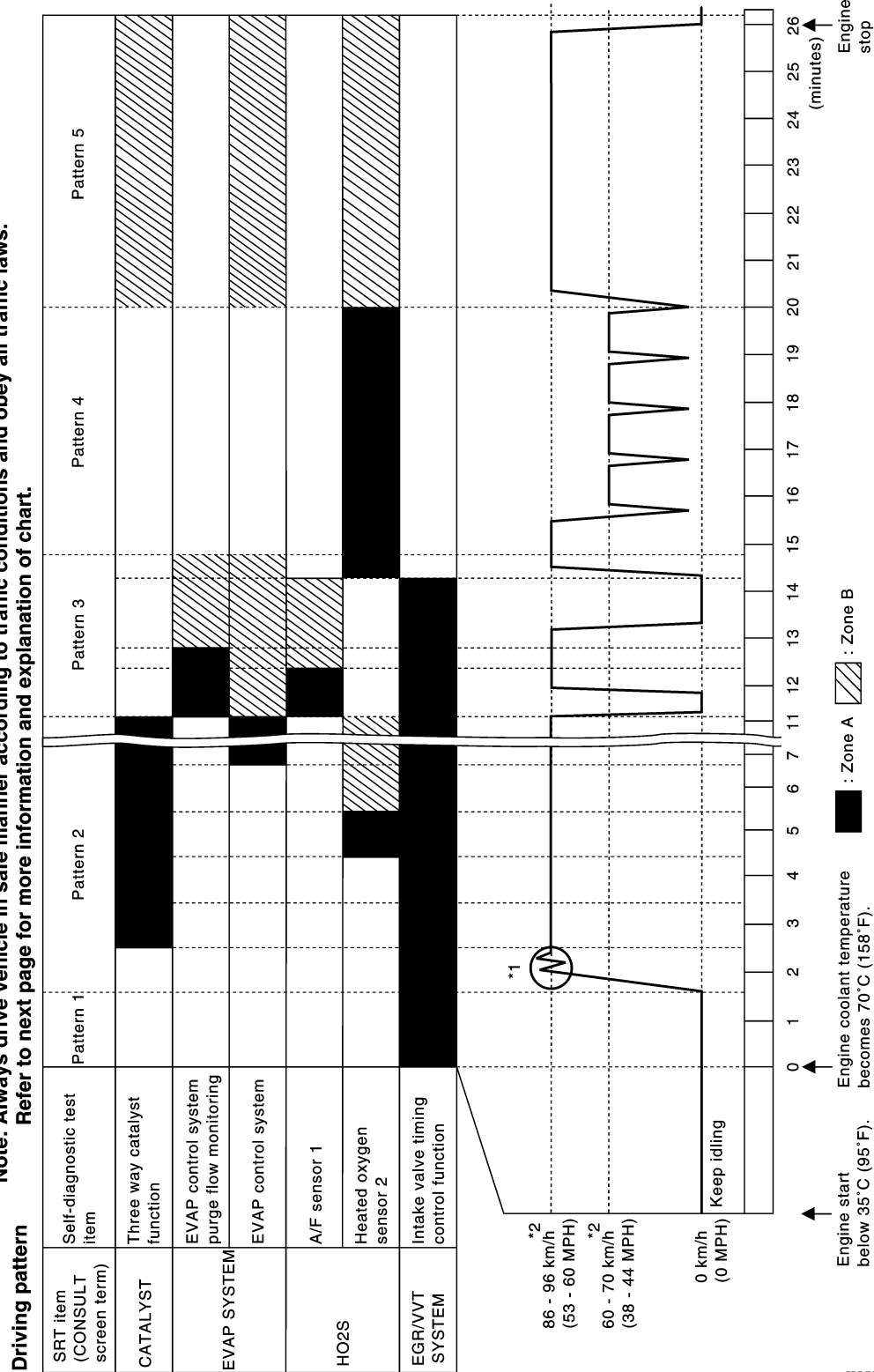

\*1: Depress the accelerator pedal until vehicle speed is 90 km/h (56 MPH), then release the accelerator pedal and keep it released for more than 10 seconds. Depress the accelerator pedal until vehicle speed is 90 km/h (56 MPH) again.

\*2: Checking the vehicle speed with GST is advised.

- The time required for each diagnosis varies with road surface conditions, weather, altitude, individual driving habits, etc.
- “Zone A” is the fastest time where required for the diagnosis under normal conditions\*. If the diagnosis is not completed within “Zone A”, the diagnosis can still be performed within “Zone B”.

# HOW TO SET SRT CODE

[QR25DE]

< BASIC INSPECTION >

\*: Normal conditions

- Sea level
- Flat road
- Ambient air temperature: 20 – 30°C (68 – 86°F)

## NOTE:

Diagnosis is performed as quickly as possible under normal conditions. However, under other conditions, diagnosis may also be performed. [For example: ambient air temperature other than 20 – 30°C (68 – 86°F)]

## Work Procedure

INFOID:000000011277910

### 1.CHECK DTC

Check DTC.

Is any DTC detected?

- YES >> Repair malfunction(s) and erase DTC. Refer to [EC-96, "DTC Index"](#).
- NO >> GO TO 2.

### 2.CHECK SRT STATUS

With CONSULT

Select "SRT STATUS" in "DTC & SRT CONFIRMATION" mode with CONSULT.

Without CONSULT

Perform "SRT status" mode with [EC-66, "On Board Diagnosis Function"](#).

With GST

Select Service \$01 with GST.

Is SRT code(s) set?

- YES >> GO TO 11.
- NO-1 >> With CONSULT: GO TO 3.
- NO-2 >> Without CONSULT: GO TO 4.

### 3.DTC CONFIRMATION PROCEDURE

1. Select "SRT WORK SUPPORT" in "DTC & SRT CONFIRMATION" mode with CONSULT.
2. For SRT(s) that is not set, perform the corresponding "DTC CONFIRMATION PROCEDURE" according to the "Performance Priority" in the "SRT ITEM" table. Refer to [EC-148, "Description"](#).
3. Check DTC.

Is any DTC detected?

- YES >> Repair malfunction(s) and erase DTC. Refer to [EC-96, "DTC Index"](#).
- NO >> GO TO 10.

### 4.PERFORM ROAD TEST

- Check the "Performance Priority" in the "SRT ITEM" table. Refer to [EC-148, "Description"](#).
- Perform the most efficient SRT set driving pattern to set the SRT properly. Refer to [EC-149, "SRT Set Driving Pattern"](#).

In order to set all SRTs, the SRT set driving pattern must be performed at least once.

>> GO TO 5.

### 5.PATTERN 1

1. Check the vehicle condition;
  - Engine coolant temperature is –10 to 35°C (14 to 95°F).
  - Fuel tank temperature is more than 0°C (32°F).
2. Start the engine.
3. Keep engine idling until the engine coolant temperature is greater than 70°C (158°F)

## NOTE:

ECM terminal voltage is follows;

- Engine coolant temperature
  - –10 to 35°C (14 to 95°F): 3.0 – 4.3 V
  - 70°(158°F): Less than 4.1 V
- Fuel tank temperature: Less than 1.4 V

Refer to [EC-80, "Reference Value"](#).

# HOW TO SET SRT CODE

< BASIC INSPECTION >

[QR25DE]

>> GO TO 6.

## 6.PATTERN 2

1. Drive the vehicle. And depress the accelerator pedal until vehicle speed is 90 km/h (56 MPH), then release the accelerator pedal and keep it released for more than 10 seconds.
2. Depress the accelerator pedal until vehicle speed is 90 km/h (56 MPH) again

### NOTE:

- Checking the vehicle speed with GST is advised.
- When steady-state driving is performed again even after it is interrupted, each diagnosis can be conducted. In this case, the time required for diagnosis may be extended.

>> GO TO 7.

## 7.PATTERN 3

- Operate vehicle following the driving pattern shown in the figure.
- Release the accelerator pedal during deceleration of vehicle speed from 90 km/h (56 MPH) to 0 km/h (0 MPH).

>> GO TO 8.

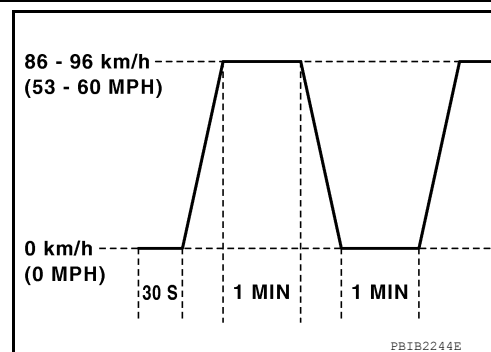

## 8.PATTERN 4

- Operate vehicle following the driving pattern shown in the figure.
- Drive the vehicle in a proper gear at 60 km/h (38 MPH) and maintain the speed.
- Release the accelerator pedal fully at least 5 seconds.
- Repeat the above two steps at least 5 times.

>> GO TO 9.

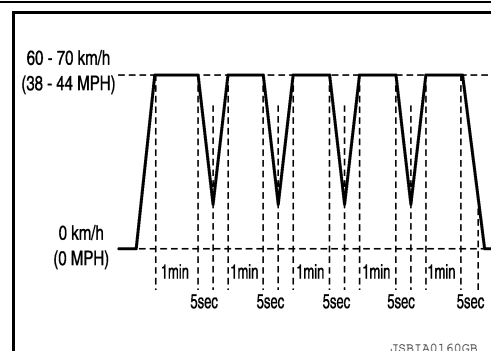

## 9.PATTERN 5

- The accelerator pedal must be held very steady during steady-state driving.
- If the accelerator pedal is moved, the test must be conducted again.

>> GO TO 10.

## 10.CHECK SRT STATUS

Ⓟ With CONSULT

Select "SRT STATUS" in "DTC & SRT CONFIRMATION" mode with CONSULT.

ⓧ Without CONSULT

Perform "SRT status" mode with [EC-66. "On Board Diagnosis Function"](#).

Ⓢ With GST

Select Service \$01 with GST.

Is SRT(s) set?

YES >> GO TO 11.

NO >> Call TECH LINE or take appropriate action.

## 11.CHECK PERMANENT DTC



# HOW TO SET SRT CODE

[QR25DE]

< BASIC INSPECTION >

**NOTE:**

Permanent DTC cannot be checked with a tool other than CONSULT or GST.

☐ With CONSULT

Select "SRT STATUS" in "DTC & SRT CONFIRMATION" mode with CONSULT.

Ⓜ With GST

Select Service \$0A with GST.

Is permanent DTC(s) detected?

YES >> Proceed to [EC-154. "Description"](#).

NO >> END

A

EC

C

D

E

F

G

H

I

J

K

L

M

N

O

P

# HOW TO ERASE PERMANENT DTC

[QR25DE]

< BASIC INSPECTION >

## HOW TO ERASE PERMANENT DTC

### Description

INFOID:000000011277911

### OUTLINE

When a DTC is stored in ECM

When a DTC is stored in ECM and MIL is ON, a permanent DTC is erased with MIL shutoff if the same malfunction is not detected after performing the driving pattern for MIL shutoff three times in a row.

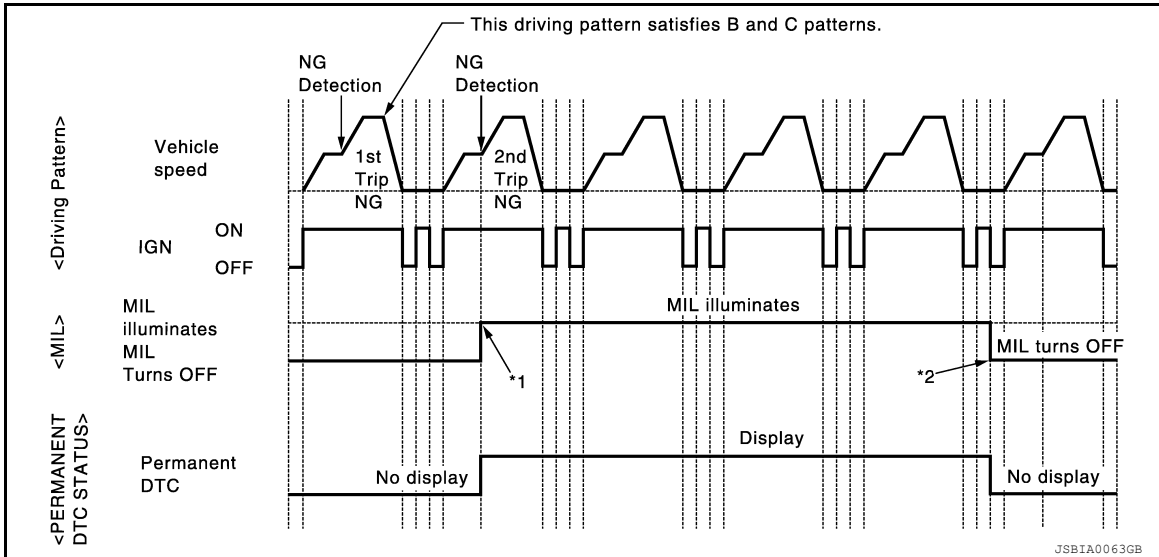

\*1: When the same malfunction is detected in two consecutive trips, MIL will illuminate.

\*2: MIL will turn off after vehicle is driven 3 times (driving pattern B) without any malfunctions.

When a DTC is not stored in ECM

The erasing method depends on a permanent DTC stored in ECM. Refer to the following table.

**NOTE:**

If the applicable permanent DTC includes multiple groups, perform the procedure of Group B first. If the permanent DTC is not erased, perform the procedure of Group A.

×: Applicable —: Not applicable

Group*	Perform "DTC CONFIRMATION PROCEDURE" for applicable DTCs.	Driving pattern		Reference
		B	D	
A	×	—	—	<a href="#">EC-155</a>
B	—	×	×	<a href="#">EC-157</a>

\*: For group, refer to [EC-96. "DTC Index"](#).

### PERMANENT DTC ITEM

For permanent DTC items, MIL turns ON. Refer to [EC-96. "DTC Index"](#).

# HOW TO ERASE PERMANENT DTC

< BASIC INSPECTION >

[QR25DE]

## PERMANENT DTC SERVICE PROCEDURE

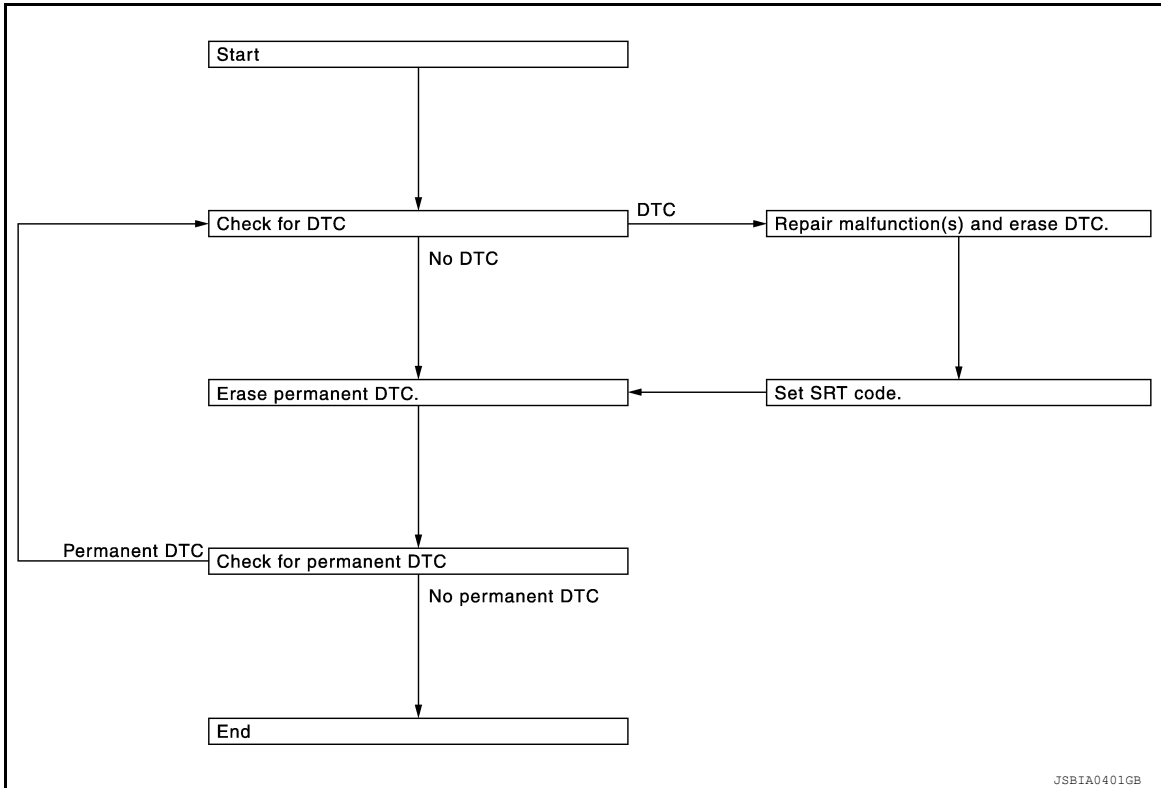

### Work Procedure (Group A)

INFOID:000000011277912

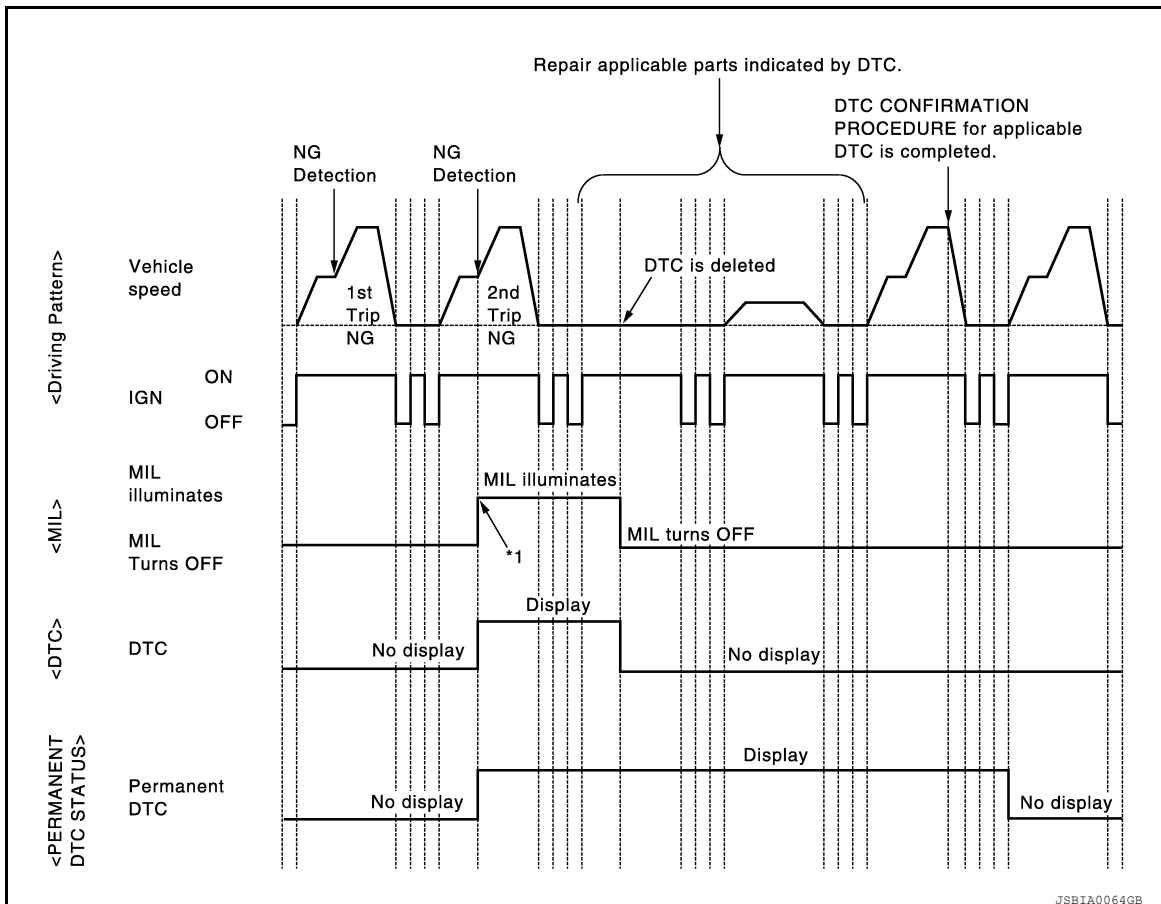

# HOW TO ERASE PERMANENT DTC

[QR25DE]

< BASIC INSPECTION >

\*1: When the same malfunction is detected in two consecutive trips, MIL will illuminate.

## 1. CHECK DTC

Check DTC.

Is any DTC detected?

YES >> Repair malfunction(s) and erase DTC.  
NO >> GO TO 2.

## 2. CHECK PERMANENT DTC

 With CONSULT

1. Turn ignition switch OFF and wait at least 10 seconds.
2. Turn ignition switch ON.
3. Turn ignition switch OFF and wait at least 10 seconds.
4. Turn ignition switch ON.
5. Select "PERMANENT DTC STATUS" mode with CONSULT.

 With GST

1. Turn ignition switch OFF and wait at least 10 seconds.
2. Turn ignition switch ON.
3. Turn ignition switch OFF and wait at least 10 seconds.
4. Turn ignition switch ON.
5. Select Service \$0A with GST.

Is any permanent DTC detected?

YES >> GO TO 3.  
NO >> END

## 3. PERFORM DTC CONFIRMATION PROCEDURE

Perform "DTC CONFIRMATION PROCEDURE" for DTCs which are the same as permanent DTCs stored in ECM. Refer to [EC-96, "DTC Index"](#).

>> GO TO 4.

## 4. CHECK PERMANENT DTC

 With CONSULT

1. Turn ignition switch OFF and wait at least 10 seconds.
2. Turn ignition switch ON.
3. Turn ignition switch OFF and wait at least 10 seconds.
4. Turn ignition switch ON.
5. Select "PERMANENT DTC STATUS" mode with CONSULT.

 With GST

1. Turn ignition switch OFF and wait at least 10 seconds.
2. Turn ignition switch ON.
3. Turn ignition switch OFF and wait at least 10 seconds.
4. Turn ignition switch ON.
5. Select Service \$0A with GST.

Is any permanent DTC detected?

YES >> GO TO 1.  
NO >> END

# HOW TO ERASE PERMANENT DTC

< BASIC INSPECTION >

[QR25DE]

## Work Procedure (Group B)

INFOID:000000011277913

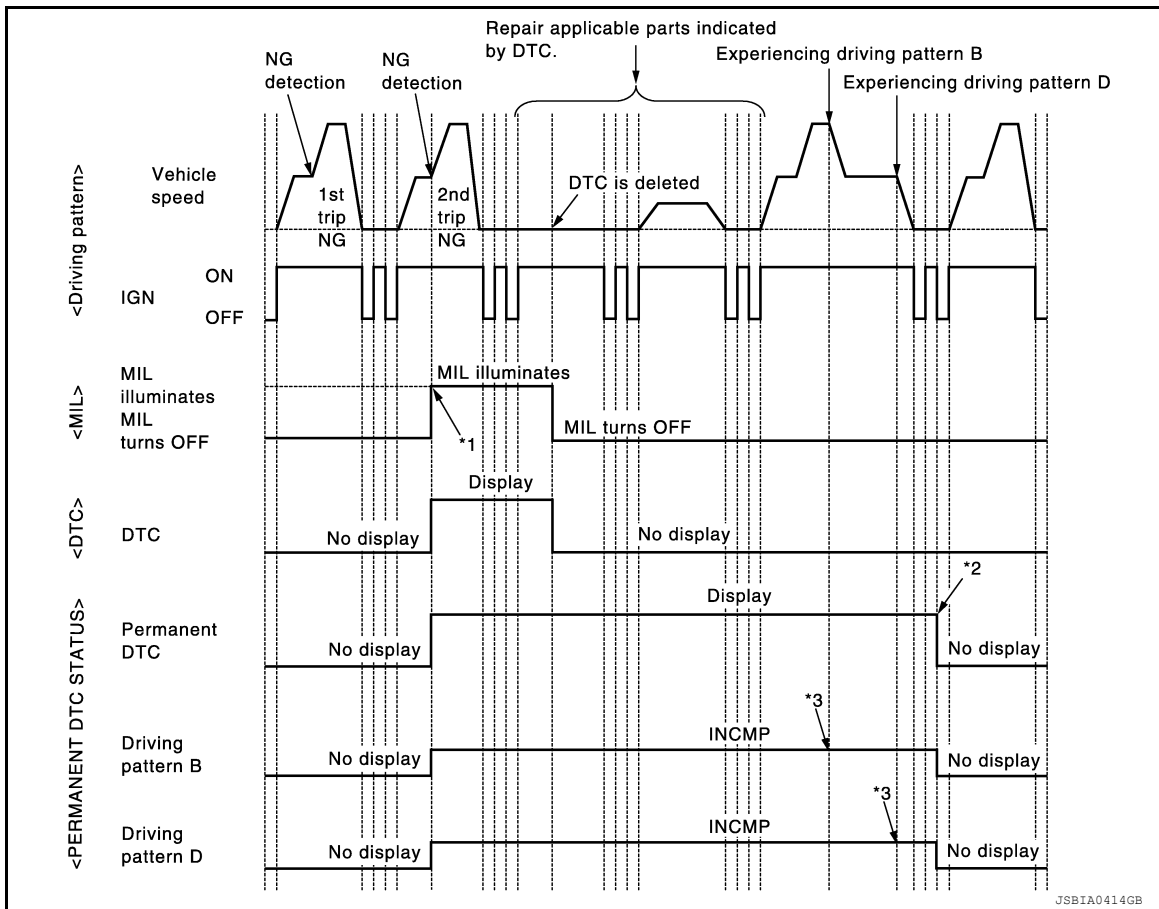

\*1: When the same malfunction is detected in two consecutive trips, MIL will illuminate.

\*2: After experiencing driving pattern B and D, permanent DTC is erased.

\*3: Indication does not change unless the ignition switch is turned from ON to OFF twice even after experiencing driving pattern B or D.

### NOTE:

Drive the vehicle according to only driving patterns indicating "INCMP" in driving patterns B and D on the "PERMANENT DTC STATUS" screen.

## 1. CHECK DTC

Check DTC.

Is any DTC detected?

YES >> Repair malfunction(s) and erase DTC.

NO >> GO TO 2.

## 2. CHECK PERMANENT DTC

Ⓜ With CONSULT

1. Turn ignition switch OFF and wait at least 10 seconds.
2. Turn ignition switch ON.
3. Turn ignition switch OFF and wait at least 10 seconds.
4. Turn ignition switch ON.
5. Select "PERMANENT DTC STATUS" mode with CONSULT.

Ⓜ With GST

1. Turn ignition switch OFF and wait at least 10 seconds.
2. Turn ignition switch ON.
3. Turn ignition switch OFF and wait at least 10 seconds.
4. Turn ignition switch ON.

## HOW TO ERASE PERMANENT DTC

[QR25DE]

< BASIC INSPECTION >

5. Select Service \$0A with GST.

Is any permanent DTC detected?

YES >> GO TO 3.

NO >> END

### 3.DRIVE DRIVING PATTERN B

#### CAUTION:

- Always drive at a safe speed.
- Never erase self-diagnosis results.
- If self-diagnosis results are erased during the trip of driving pattern B or D, the counter of driving pattern B and D is reset.

 With CONSULT

1. Start engine and warm it up to normal operating temperature.
2. Use "PERMANENT DTC WORK SUPPORT" mode with CONSULT to drive the vehicle according to driving pattern B. Refer to [EC-69. "CONSULT Function"](#), [EC-63. "DIAGNOSIS DESCRIPTION : Driving Pattern"](#).

 With GST

1. Start engine and warm it up to normal operating temperature.
2. Drive the vehicle according to driving pattern B. Refer to [EC-63. "DIAGNOSIS DESCRIPTION : Driving Pattern"](#).

>> GO TO 4.

### 4.CHECK PERMANENT DTC

 With CONSULT

1. Turn ignition switch OFF and wait at least 10 seconds.
2. Turn ignition switch ON.
3. Turn ignition switch OFF and wait at least 10 seconds.
4. Turn ignition switch ON.
5. Select "PERMANENT DTC STATUS" mode with CONSULT.

 With GST

1. Turn ignition switch OFF and wait at least 10 seconds.
2. Turn ignition switch ON.
3. Turn ignition switch OFF and wait at least 10 seconds.
4. Turn ignition switch ON.
5. Select Service \$0A with GST.

Is any permanent DTC detected?

YES >> GO TO 5.

NO >> END

### 5.DRIVE DRIVING PATTERN D

#### CAUTION:

- Always drive at a safe speed.
- Never erase self-diagnosis results.
- If self-diagnosis results are erased during the trip of driving pattern B or D, the counter of driving pattern B and D is reset.

Drive the vehicle according to driving pattern D. Refer to [EC-63. "DIAGNOSIS DESCRIPTION : Driving Pattern"](#).

>> GO TO 6.

### 6.CHECK PERMANENT DTC

 With CONSULT

1. Turn ignition switch OFF and wait at least 10 seconds.
2. Turn ignition switch ON.
3. Turn ignition switch OFF and wait at least 10 seconds.
4. Turn ignition switch ON.
5. Select "PERMANENT DTC STATUS" mode with CONSULT.

# HOW TO ERASE PERMANENT DTC

[QR25DE]

< BASIC INSPECTION >

 With GST

1. Turn ignition switch OFF and wait at least 10 seconds.
2. Turn ignition switch ON.
3. Turn ignition switch OFF and wait at least 10 seconds.
4. Turn ignition switch ON.
5. Select Service \$0A with GST.

Is any permanent DTC detected?

- YES >> GO TO 1.  
NO >> END

A

EC

C

D

E

F

G

H

I

J

K

L

M

N

O

P

## DTC/CIRCUIT DIAGNOSIS

### TROUBLE DIAGNOSIS - SPECIFICATION VALUE

#### Description

INFOID:0000000011277914

The specification (SP) value indicates the tolerance of the value that is displayed in "SPEC" of "DATA MONITOR" mode of CONSULT during normal operation of the Engine Control System. When the value in "SPEC" of "DATA MONITOR" mode is within the SP value, the Engine Control System is confirmed OK. When the value in "SPEC" of "DATA MONITOR" mode is NOT within the SP value, the Engine Control System may have one or more malfunctions.

The SP value is used to detect malfunctions that may affect the Engine Control System, but will not light the MIL.

The SP value will be displayed for the following three items:

- B/FUEL SCHDL (The fuel injection pulse width programmed into ECM prior to any learned on board correction)
- A/F ALPHA-B1 (The mean value of air-fuel ratio feedback correction factor per cycle)
- MASS AIR FLOW SENSOR (Hz) (The signal frequency of the mass air flow sensor)

#### Component Function Check

INFOID:0000000011277915

#### 1. START

Make sure that all of the following conditions are satisfied.

- Vehicle driven distance: More than 5,000 km (3,107 miles)
- Barometric pressure: 98.3 - 104.3 kPa (1.003 - 1.064 kg/cm<sup>2</sup>, 14.25 - 15.12 psi)
- Atmospheric temperature: 20 - 30°C (68 - 86°F)
- Engine coolant temperature: 75 - 95°C (167 - 203°F)
- Transmission: Warmed-up
- After the engine is warmed up to normal operating temperature, drive vehicle until "ATF TEMP SEN" (CVT fluid temperature sensor signal) indicates more than 60°C (140°F).
- Electrical load: Not applied\*
- Engine speed: Idle

\*: Rear window defogger switch, air conditioner switch, lighting switch are OFF. Steering wheel is straight ahead.

>> GO TO 2.

#### 2. PERFORM "SPEC" OF "DATA MONITOR" MODE

##### With CONSULT

##### NOTE:

Perform "SPEC" in "DATA MONITOR" mode in maximum scale display.

1. Perform [EC-135. "Work Procedure"](#).
2. Select "B/FUEL SCHDL", "A/F ALPHA-B1" and "MASS AIR FLOW SENSOR (Hz)" in "SPEC" of "DATA MONITOR" mode with CONSULT.
3. Make sure that monitor items are within the SP value.

Is the inspection result normal?

YES >> END

NO >> Proceed to [EC-161. "Diagnosis Procedure"](#).



# TROUBLE DIAGNOSIS - SPECIFICATION VALUE

< DTC/CIRCUIT DIAGNOSIS >

[QR25DE]

## Diagnosis Procedure

INFOID:000000011277916

### OVERALL SEQUENCE

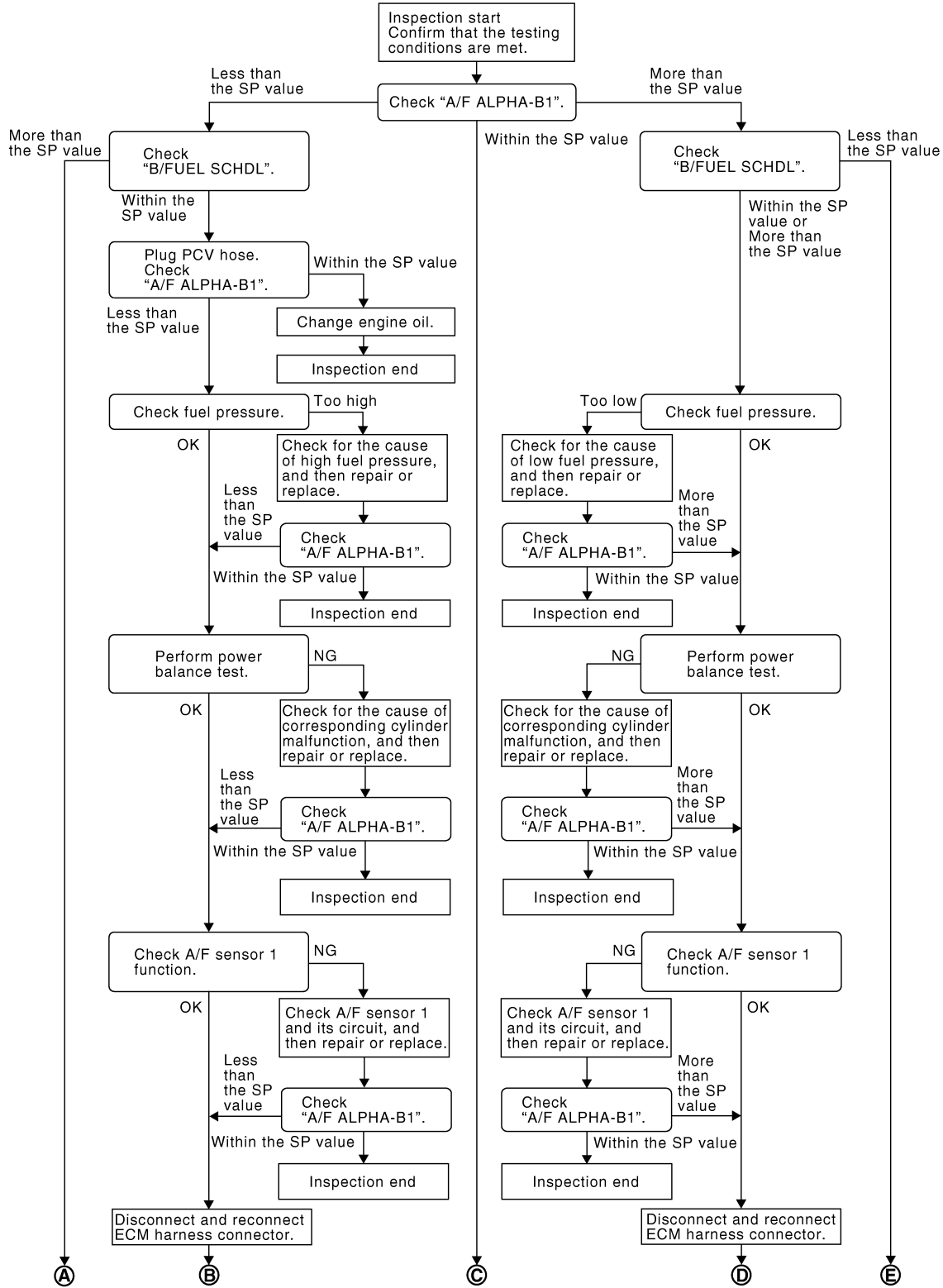

PBIB2318E

A  
EC  
C  
D  
E  
F  
G  
H  
I  
J  
K  
L  
M  
N  
O  
P

# TROUBLE DIAGNOSIS - SPECIFICATION VALUE

< DTC/CIRCUIT DIAGNOSIS >

[QR25DE]

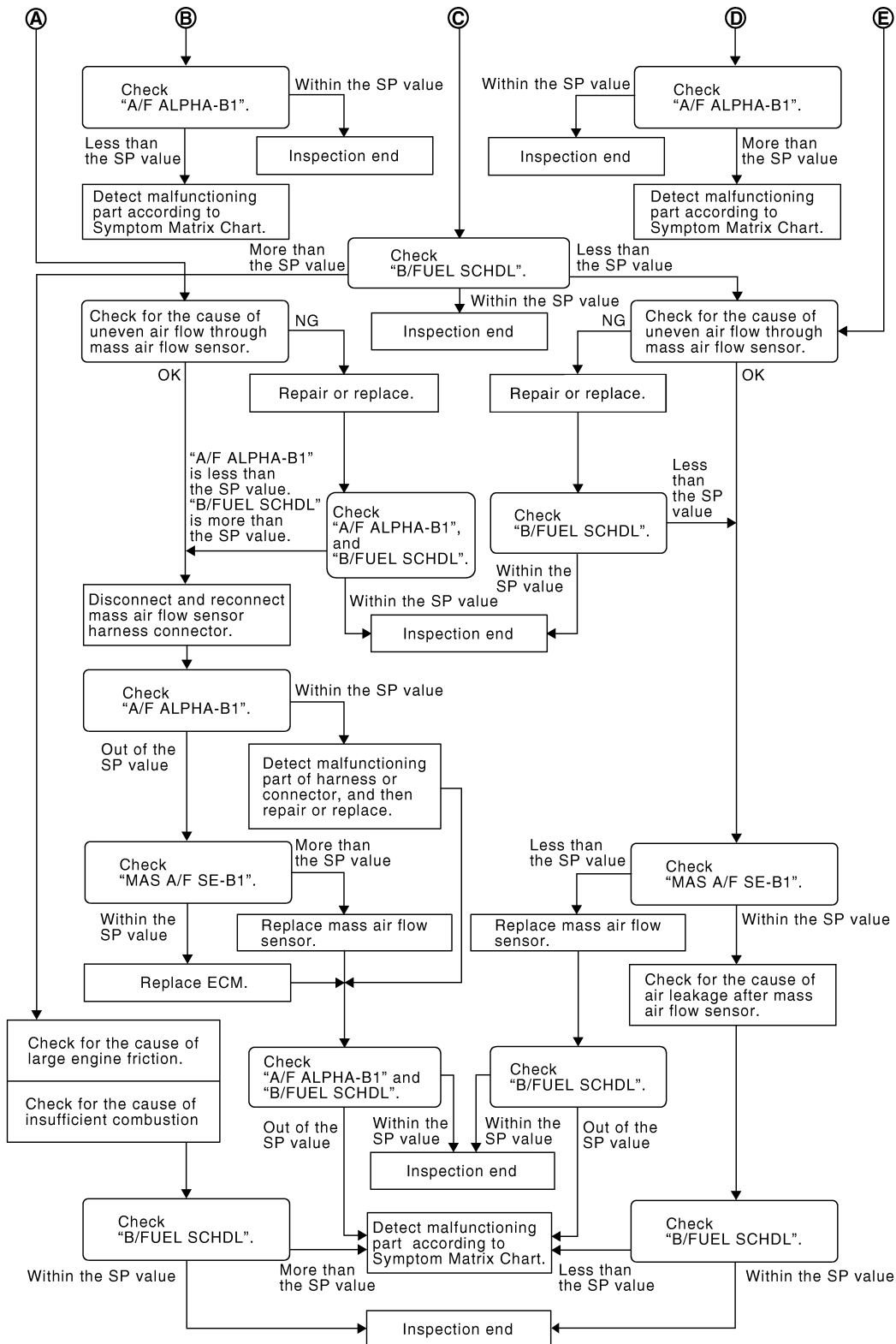

PBIB3213E

## DETAILED PROCEDURE

### 1. CHECK "A/F ALPHA-B1"

#### ④ With CONSULT

1. Start engine.
2. Confirm that the testing conditions are met. Refer to [EC-160, "Component Function Check"](#).
3. Select "A/F ALPHA-B1" in "SPEC" of "DATA MONITOR" mode, and make sure that the each indication is within the SP value.

# TROUBLE DIAGNOSIS - SPECIFICATION VALUE

[QR25DE]

< DTC/CIRCUIT DIAGNOSIS >

## NOTE:

Check "A/F ALPHA-B1" for approximately 1 minute because they may fluctuate. It is NG if the indication is out of the SP value even a little.

Is the measurement value within the SP value?

YES >> GO TO 17.

NO-1 >> Less than the SP value: GO TO 2.

NO-2 >> More than the SP value: GO TO 3.

## 2.CHECK "B/FUEL SCHDL"

Select "B/FUEL SCHDL" in "SPEC" of "DATA MONITOR" mode, and make sure that the indication is within the SP value.

Is the measurement value within the SP value?

YES >> GO TO 4.

NO >> More than the SP value: GO TO 19.

## 3.CHECK "B/FUEL SCHDL"

Select "B/FUEL SCHDL" in "SPEC" of "DATA MONITOR" mode, and make sure that the indication is within the SP value.

Is the measurement value within the SP value?

YES >> GO TO 6.

NO-1 >> More than the SP value: GO TO 6.

NO-2 >> Less than the SP value: GO TO 25.

## 4.CHECK "A/F ALPHA-B1"

1. Stop the engine.

2. Disconnect PCV hose, and then plug it.

3. Start engine.

4. Select "A/F ALPHA-B1" in "SPEC" of "DATA MONITOR" mode, and make sure that the indication is within the SP value.

Is the measurement value within the SP value?

YES >> GO TO 5.

NO >> GO TO 6.

## 5.CHANGE ENGINE OIL

1. Stop the engine.

2. Change engine oil.

## NOTE:

This symptom may occur when a large amount of gasoline is mixed with engine oil because of driving conditions (such as when engine oil temperature does not rise enough since a journey distance is too short during winter). The symptom will not be detected after changing engine oil or changing driving condition.

>> **INSPECTION END**

## 6.CHECK FUEL PRESSURE

Check fuel pressure. (Refer to [EC-147, "Work Procedure"](#).)

Is the inspection result normal?

YES >> GO TO 9.

NO-1 >> Fuel pressure is too high: Replace "fuel filter and fuel pump assembly", refer to [FL-5, "Removal and Installation"](#), and then GO TO 8.

NO-2 >> Fuel pressure is too low: GO TO 7.

## 7.DETECT MALFUNCTIONING PART

Check fuel hoses and fuel tubes for clogging

Is the inspection result normal?

YES >> Replace "fuel filter and fuel pump assembly", refer to [FL-5, "Removal and Installation"](#), and then GO TO 8.

NO >> Repair or replace and then GO TO 8.

# TROUBLE DIAGNOSIS - SPECIFICATION VALUE

[QR25DE]

< DTC/CIRCUIT DIAGNOSIS >

## 8. CHECK "A/F ALPHA-B1"

1. Start engine.
2. Select "A/F ALPHA-B1" in "SPEC" of "DATA MONITOR" mode, and make sure that the indication is within the SP value.

Is the measurement value within the SP value?

- YES >> INSPECTION END  
NO >> GO TO 9.

## 9. PERFORM POWER BALANCE TEST

1. Perform "POWER BALANCE" in "ACTIVE TEST" mode.
2. Make sure that the each cylinder produces a momentary engine speed drop.

Is the inspection result normal?

- YES >> GO TO 12.  
NO >> GO TO 10.

## 10. DETECT MALFUNCTIONING PART

Check the following.

1. Ignition coil and its circuit (Refer to [EC-473, "Component Function Check".](#))
2. Fuel injector and its circuit (Refer to [EC-467, "Component Function Check".](#))
3. Intake air leakage
4. Low compression pressure (Refer to [EM-24, "Compression pressure".](#))

Is the inspection result normal?

- YES >> Replace fuel injector, refer to [EM-45, "Removal and Installation"](#), and then GO TO 11.  
NO >> Repair or replace malfunctioning part and then GO TO 11.

## 11. CHECK "A/F ALPHA-B1"

1. Start engine.
2. Select "A/F ALPHA-B1" in "SPEC" of "DATA MONITOR" mode, and make sure that the indication is within the SP value.

Is the measurement value within the SP value?

- YES >> INSPECTION END  
NO >> GO TO 12.

## 12. CHECK A/F SENSOR 1 FUNCTION

Perform all DTC CONFIRMATION PROCEDURE related with A/F sensor 1.

- For DTC P0130, refer to [EC-229, "DTC Description"](#).
- For DTC P0131, refer to [EC-233, "DTC Description"](#).
- For DTC P0132, refer to [EC-236, "DTC Description"](#).
- For DTC P014C, P014D, P15A, P15B refer to [EC-258, "DTC Description"](#).
- For DTC P2096, P2097, refer to [EC-429, "DTC Description"](#).

Is any DTC detected?

- YES >> GO TO 15.  
NO >> GO TO 13.

## 13. CHECK A/F SENSOR 1 CIRCUIT

Perform DIAGNOSTIC PROCEDURE according to corresponding DTC.

>> GO TO 14.

## 14. CHECK "A/F ALPHA-B1"

1. Start engine.
2. Select "A/F ALPHA-B1" in "SPEC" of "DATA MONITOR" mode, and make sure that the each indication is within the SP value.

Is the measurement value within the SP value?

- YES >> INSPECTION END  
NO >> GO TO 15.

# TROUBLE DIAGNOSIS - SPECIFICATION VALUE

< DTC/CIRCUIT DIAGNOSIS >

[QR25DE]

## 15.DISCONNECT AND RECONNECT ECM HARNESS CONNECTOR

1. Stop the engine.
2. Disconnect ECM harness connector. Check pin terminal and connector for damage, and then reconnect it.

>> GO TO 16.

## 16.CHECK "A/F ALPHA-B1"

1. Start engine.
2. Select "A/F ALPHA-B1" in "SPEC" of "DATA MONITOR" mode, and make sure that the indication is within the SP value.

Is the measurement value within the SP value?

YES >> INSPECTION END

NO >> Detect malfunctioning part according to [EC-489. "Symptom Table"](#).

## 17.CHECK "B/FUEL SCHDL"

Select "B/FUEL SCHDL" in "SPEC" of "DATA MONITOR" mode, and make sure that the indication is within the SP value.

Is the measurement value within the SP value?

YES >> INSPECTION END

NO-1 >> More than the SP value: GO TO 18.

NO-2 >> Less than the SP value: GO TO 25.

## 18.DETECT MALFUNCTIONING PART

1. Check for the cause of large engine friction. Refer to the following.
  - Engine oil level is too high
  - Engine oil viscosity
  - Belt tension of power steering, alternator, A/C compressor, etc. is excessive
  - Noise from engine
  - Noise from transmission, etc.
2. Check for the cause of insufficient combustion. Refer to the following.
  - Valve clearance malfunction
  - Intake valve timing control function malfunction
  - Camshaft sprocket installation malfunction, etc.

>> Repair or replace malfunctioning part, and then GO TO 30.

## 19.CHECK INTAKE SYSTEM

Check for the cause of uneven air flow through mass air flow sensor. Refer to the following.

- Crushed air ducts
- Malfunctioning seal of air cleaner element
- Uneven dirt of air cleaner element
- Improper specification of intake air system

Is the inspection result normal?

YES >> GO TO 21.

NO >> Repair or replace malfunctioning part, and then GO TO 20.

## 20.CHECK "A/F ALPHA-B1", AND "B/FUEL SCHDL"

Select "A/F ALPHA-B1" and "B/FUEL SCHDL" in "SPEC" of "DATA MONITOR" mode, and make sure that the each indication is within the SP value.

Is the measurement value within the SP value?

YES >> **INSPECTION END**

NO >> "B/FUEL SCHDL" is more, "A/F ALPHA-B1" is less than the SP value: GO TO 21.

## 21.DISCONNECT AND RECONNECT MASS AIR FLOW SENSOR HARNESS CONNECTOR

1. Stop the engine.
2. Disconnect mass air flow sensor harness connector. Check pin terminal and connector for damage and then reconnect it again.

## TROUBLE DIAGNOSIS - SPECIFICATION VALUE

< DTC/CIRCUIT DIAGNOSIS >

[QR25DE]

>> GO TO 22.

### 22. CHECK "A/F ALPHA-B1"

1. Start engine.
2. Select "A/F ALPHA-B1" in "SPEC" of "DATA MONITOR" mode, and make sure that the indication is within the SP value.

Is the measurement value within the SP value?

YES >> Detect malfunctioning part of mass air flow sensor circuit and repair it. Refer to [EC-201, "DTC Description"](#). Then GO TO 29.

NO >> GO TO 23.

### 23. CHECK "MASS AIR FLOW SENSOR (HZ)"

Select "MASS AIR FLOW SENSOR (Hz)" in "SPEC" of "DATA MONITOR" mode, and make sure that the indication is within the SP value.

Is the measurement value within the SP value?

YES >> GO TO 24.

NO >> More than the SP value: Replace mass air flow sensor, refer to [EM-26, "Removal and Installation"](#), and then GO TO 29.

### 24. REPLACE ECM

Replace ECM. Refer to [EC-502, "Removal and Installation"](#).

>> GO TO 29.

### 25. CHECK INTAKE SYSTEM

Check for the cause of uneven air flow through mass air flow sensor. Refer to the following.

- Crushed air ducts
- Malfunctioning seal of air cleaner element
- Uneven dirt of air cleaner element
- Improper specification of intake air system

Is the inspection result normal?

YES >> GO TO 27.

NO >> Repair or replace malfunctioning part, and then GO TO 26.

### 26. CHECK "B/FUEL SCHDL"

Select "B/FUEL SCHDL" in "SPEC" of "DATA MONITOR" mode, and make sure that the indication is within the SP value.

Is the measurement value within the SP value?

YES >> INSPECTION END

NO >> Less than the SP value: GO TO 27.

### 27. CHECK "MASS AIR FLOW SENSOR (HZ)"

Select "MASS AIR FLOW SENSOR (Hz)" in "SPEC" of "DATA MONITOR" mode, and make sure that the indication is within the SP value.

Is the measurement value within the SP value?

YES >> GO TO 28.

NO >> Less than the SP value: Replace mass air flow sensor, refer to [EM-26, "Removal and Installation"](#), and then GO TO 30.

### 28. CHECK INTAKE SYSTEM

Check for the cause of air leak after the mass air flow sensor. Refer to the following.

- Disconnection, looseness, and cracks in air duct
- Looseness of oil filler cap
- Disconnection of oil level gauge
- Open stuck, breakage, hose disconnection, or cracks of PCV valve
- Disconnection or cracks of EVAP purge hose, open stuck of EVAP canister purge volume control solenoid valve

## TROUBLE DIAGNOSIS - SPECIFICATION VALUE

[QR25DE]

< DTC/CIRCUIT DIAGNOSIS >

- Malfunctioning seal of rocker cover gasket
- Disconnection, looseness, or cracks of hoses, such as vacuum hose, connecting to intake air system parts
- Malfunctioning seal of intake air system, etc.

A

>> GO TO 30.

### 29.CHECK "A/F ALPHA-B1" AND "B/FUEL SCHDL"

Select "A/F ALPHA-B1" and "B/FUEL SCHDL" in "SPEC" of "DATA MONITOR" mode, and make sure that the indication is within the SP value.

C

Is the measurement value within the SP value?

YES >> INSPECTION END

D

NO >> Detect malfunctioning part according to [EC-489. "Symptom Table"](#).

### 30.CHECK "B/FUEL SCHDL"

Select "B/FUEL SCHDL" in "SPEC" of "DATA MONITOR" mode, and then make sure that the indication is within the SP value.

E

Is the measurement value within the SP value?

YES >> INSPECTION END

F

NO >> Detect malfunctioning part according to [EC-489. "Symptom Table"](#).

G

H

I

J

K

L

M

N

O

P

EC

# POWER SUPPLY AND GROUND CIRCUIT

< DTC/CIRCUIT DIAGNOSIS >

[QR25DE]

## POWER SUPPLY AND GROUND CIRCUIT

### Diagnosis Procedure

INFOID:00000001127917

#### 1. CHECK FUSE

Check that the following fuse is not fusing.

Location	Fuse No.	Capacity
IPDM E/R	#48	5 A
	#41	10 A
	#35	15 A

Is the fuse fusing?

YES >> Replace the fuse after repairing the applicable circuit.

NO >> GO TO 2.

#### 2. CHECK GROUND CONNECTION

1. Turn ignition switch OFF.
2. Check ground connection E9 or E15. Refer to [GI-46. "Circuit Inspection"](#).

Is the inspection result normal?

YES >> GO TO 3.

NO >> Repair or replace ground connection.

#### 3. CHECK ECM GROUND CIRCUIT

1. Disconnect ECM harness connectors.
2. Check the continuity between ECM harness connector and ground.

+		-	Continuity
ECM			
Connector	Terminal	Ground	Existed
F52	52		
F51	16		
E16	123		
	128		

Is the inspection result normal?

YES >> GO TO 4.

NO >> Repair or replace error-detected parts.

#### 4. CHECK ECM POWER SUPPLY (MAIN)-1

1. Reconnect ECM harness connector.
2. Turn ignition switch ON.
3. Check the voltage between ECM harness connector terminals.

Connector	ECM		Voltage
	+	-	
	Terminal		
E16	121	128	Battery voltage

Is the inspection result normal?

YES >> GO TO 5.

NO >> GO TO 6.

#### 5. CHECK ECM POWER SUPPLY (MAIN)--2

1. Turn ignition switch OFF and wait at least 10 seconds.



# POWER SUPPLY AND GROUND CIRCUIT

[QR25DE]

< DTC/CIRCUIT DIAGNOSIS >

2. Check the voltage between ECM harness connector terminals as per the following.

ECM			Condition	Voltage (Approx.)
Connector	+	-		
	Terminal			
E16	121	128	After turning ignition switch OFF, battery voltage will exist for a few seconds	Drop to 0 V

Is the inspection result normal?

YES >> GO TO 9.

NO >> GO TO 7.

## 6. CHECK ECM POWER SUPPLY (MAIN) CIRCUIT

1. Turn ignition switch OFF.
2. Disconnect ECM harness connectors.
3. Disconnect IPDM E/R harness connector.
4. Check the continuity between ECM harness connector and IPDM E/R harness connector.

+		-		Continuity
ECM		IPDM E/R		
Connector	Terminal	Connector	Terminal	
E16	121	F35	73	Existed

5. Also check harness for short to ground.

Is the inspection result normal?

YES >> Perform the trouble diagnosis for power supply circuit.

NO >> Repair or replace error-detected parts.

## 7. CHECK ECM RELAY CONTROL SIGNAL

Check the voltage between ECM harness connector terminals as per the following.

ECM				Condition	Voltage (Approx.)
+		-			
Connector	Terminal	Connector	Terminal		
F52	89	E16	128	Ignition switch ON	0 V
				Turn ignition switch OFF and wait at least 10 seconds.	Battery voltage

Is the inspection result normal?

YES >> Check Intermittent Incident. Refer to [GI-44, "Intermittent Incident"](#).

NO >> GO TO 8.

## 8. CHECK ECM RELAY CONTROL SIGNAL CIRCUIT

1. Turn ignition switch OFF.
2. Disconnect ECM harness connector.
3. Disconnect IPDM E/R harness connector.
4. Check the continuity between ECM harness connector and IPDM E/R harness connector.

+		-		Continuity
ECM		IPDM E/R		
Connector	Terminal	Connector	Terminal	
F52	89	F42	93	Existed

5. Also check harness for short to ground and to power.

# POWER SUPPLY AND GROUND CIRCUIT

[QR25DE]

< DTC/CIRCUIT DIAGNOSIS >

Is the inspection result normal?

YES >> Replace IPDM E/R. Refer to [PCS-40, "Removal and Installation"](#).

NO >> Repair or replace error-detected parts.

## 9. CHECK IGNITION SWITCH SIGNAL

1. Turn ignition switch ON.
2. Check the voltage between ECM harness connector terminals.

ECM			Condition	Voltage (Approx.)
Connector	+	-		
	Terminal			
E16	109	128	Ignition switch OFF	0 V
			Ignition switch ON	Battery voltage

Is the inspection result normal?

YES >> GO TO 11.

NO >> GO TO 10.

## 10. CHECK IGNITION SWITCH SIGNAL CIRCUIT

1. Turn ignition switch OFF.
2. Disconnect ECM harness connector.
3. Disconnect IPDM E/R harness connector.
4. Check the continuity between ECM harness connector and IPDM E/R harness connector.

+		-		Continuity
ECM		IPDM E/R		
Connector	Terminal	Connector	Terminal	
E16	109	E120	19	Existed

5. Also check harness for short to ground and to power.

Is the inspection result normal?

YES >> Perform the trouble diagnosis for power supply circuit.

NO >> Repair or replace error-detected parts.

## 11. CHECK ECM POWER SUPPLY (BACK-UP)

Check the voltage between ECM harness connector terminals.

ECM				Voltage
+		-		
Connector	Terminal	Connector	Terminal	
F52	81	E16	128	Battery voltage

Is the inspection result normal?

YES >> Check Intermittent Incident. Refer to [GI-44, "Intermittent Incident"](#).

NO >> GO TO 12.

## 12. CHECK ECM POWER SUPPLY (BACK-UP) CIRCUIT

1. Turn ignition switch OFF.
2. Disconnect ECM harness connector.
3. Disconnect IPDM E/R harness connector.
4. Check the continuity between ECM harness connector and IPDM E/R harness connector.

# POWER SUPPLY AND GROUND CIRCUIT

< DTC/CIRCUIT DIAGNOSIS >

[QR25DE]

+		-		Continuity
ECM		IPDM E/R		
Connector	Terminal	Connector	Terminal	
F52	81	E121	44	Existed

5. Also check harness for short to ground and to power.

Is the inspection result normal?

- YES >> Perform the trouble diagnosis for power supply circuit.
- NO >> Repair or replace error-detected parts.

A

EC

C

D

E

F

G

H

I

J

K

L

M

N

O

P

# U0101 CAN COMM CIRCUIT

< DTC/CIRCUIT DIAGNOSIS >

[QR25DE]

## U0101 CAN COMM CIRCUIT

### Description

INFOID:000000011277918

CAN (Controller Area Network) is a serial communication line for real time application. It is an on-vehicle multiplex communication line with high data communication speed and excellent error detection ability. Many electronic control units are equipped onto a vehicle, and each control unit shares information and links with other control units during operation (not independent). In CAN communication, control units are connected with 2 communication lines (CAN H line, CAN L line) allowing a high rate of information transmission with less wiring. Each control unit transmits/receives data but selectively reads required data only.

### DTC Description

INFOID:000000011277919

### DTC DETECTION LOGIC

DTC No.	CONSULT screen terms (Trouble diagnosis content)	DTC detecting condition
U0101	LOST COMM (TCM) (Lost communication with TCM)	When ECM is not transmitting or receiving CAN communication signal of OBD (emission-related diagnosis) with TCM for 2 seconds or more.

### POSSIBLE CAUSE

CAN communication line between TCM and ECM

### FAIL-SAFE

Not applicable

### DTC CONFIRMATION PROCEDURE

#### 1. PERFORM DTC CONFIRMATION PROCEDURE

1. Turn ignition switch ON and wait at least 3 seconds.
2. Check DTC.

#### Is DTC detected?

- YES >> Proceed to [EC-172, "Diagnosis Procedure"](#).  
NO >> INSPECTION END

### Diagnosis Procedure

INFOID:000000011277920

Perform the trouble diagnosis for CAN communication system. Refer to [LAN-17, "Trouble Diagnosis Flow Chart"](#).

# U1001 CAN COMM CIRCUIT

< DTC/CIRCUIT DIAGNOSIS >

[QR25DE]

## U1001 CAN COMM CIRCUIT

### Description

INFOID:0000000011277921

CAN (Controller Area Network) is a serial communication line for real time application. It is an on-vehicle multiplex communication line with high data communication speed and excellent error detection ability. Many electronic control units are equipped onto a vehicle, and each control unit shares information and links with other control units during operation (not independent). In CAN communication, control units are connected with 2 communication lines (CAN H line, CAN L line) allowing a high rate of information transmission with less wiring. Each control unit transmits/receives data but selectively reads required data only.

### DTC Description

INFOID:0000000011277922

### DTC DETECTION LOGIC

DTC No.	CONSULT screen terms (Trouble diagnosis content)	DTC detecting condition
U1001	CAN COMM CIRCUIT (CAN COMM CIRCUIT)	When ECM is not transmitting or receiving CAN communication signal other than OBD (emission related diagnosis) for 2 seconds or more.

### POSSIBLE CAUSE

Harness or connectors (CAN communication line is open or shorted)

### FAIL-SAFE

Not applicable

### DTC CONFIRMATION PROCEDURE

#### 1. PERFORM DTC CONFIRMATION PROCEDURE

1. Turn ignition switch ON and wait at least 3 seconds.
2. Check 1st trip DTC.

#### Is 1st trip DTC detected?

- YES >> Proceed to [EC-173, "Diagnosis Procedure"](#).  
NO >> INSPECTION END

### Diagnosis Procedure

INFOID:0000000011277923

Perform the trouble diagnosis for CAN communication system. Refer to [LAN-17, "Trouble Diagnosis Flow Chart"](#).

# U1040 ENG COMM CIRCUIT

< DTC/CIRCUIT DIAGNOSIS >

[QR25DE]

## U1040 ENG COMM CIRCUIT

### DTC Description

INFOID:000000011277924

### DTC DETECTION LOGIC

DTC	CONSULT screen terms (Trouble diagnosis content)	DTC detecting condition
U1040	ENG COMM CIRCUIT (Engine communication circuit)	ECM cannot transmit a communication signal to generator.

### POSSIBLE CAUSE

- Harness or connectors  
(LIN communication circuit is open or shorted.)
- ECM

### FAIL-SAFE

Not applicable

### DTC CONFIRMATION PROCEDURE

#### 1. PRECONDITIONING

If DTC Confirmation Procedure has been previously conducted, always perform the following procedure before conducting the next test.

1. Turn ignition switch OFF and wait at least 10 seconds.
2. Turn ignition switch ON.
3. Turn ignition switch OFF and wait at least 10 seconds.

>> GO TO 2.

#### 2. PERFORM DTC CONFIRMATION PROCEDURE

1. Turn ignition ON and wait at least 10 seconds.
2. Check DTC.

Is DTC detected?

- YES >> Proceed to [EC-174, "Diagnosis Procedure"](#).  
NO >> INSPECTION END

### Diagnosis Procedure

INFOID:000000011277925

#### 1. CHECK LIN COMMUNICATION CIRCUIT

1. Turn ignition switch OFF.
2. Disconnect ECM harness connector and generator harness connector.
3. Check the continuity between ECM harness connector and generator harness connector.

+		-		Continuity
ECM		Generator		
Connector	Terminal	Connector	Terminal	
F52	85	F31	2	Existed

4. Also check harness for short to power and short to ground.

Is the inspection result normal?

- YES >> GO TO 2.  
NO >> Repair or replace error-detected parts.

#### 2. REPLACE GENERATOR

1. Replace generator. Refer to [CHG-20, "Removal and Installation"](#).
2. Erase DTC.
3. Perform DTC confirmation procedure again. Refer to [EC-174, "DTC Description"](#).

# U1040 ENG COMM CIRCUIT

< DTC/CIRCUIT DIAGNOSIS >

[QR25DE]

Is DTC detected again?

YES >> Replace ECM. Refer to [EC-502, "Removal and Installation"](#).

NO >> INSPECTION END

A

EC

C

D

E

F

G

H

I

J

K

L

M

N

O

P

# U1044 ENG COMM CIRCUIT

< DTC/CIRCUIT DIAGNOSIS >

[QR25DE]

## U1044 ENG COMM CIRCUIT

### DTC Description

INFOID:000000011277926

### DTC DETECTION LOGIC

DTC	CONSULT screen terms (Trouble diagnosis content)	DTC detecting condition
U1044	ENG COMM CIRCUIT (Engine communication circuit)	A signal voltage of LIN communication between ECM and generator is excessively low or excessively high.

### POSSIBLE CAUSE

- Harness or connectors  
(LIN communication circuit is open or shorted.)
- Generator

### FAIL-SAFE

Not applicable

### DTC CONFIRMATION PROCEDURE

#### 1. PRECONDITIONING

If DTC Confirmation Procedure has been previously conducted, always perform the following procedure before conducting the next test.

1. Turn ignition switch OFF and wait at least 10 seconds.
2. Turn ignition switch ON.
3. Turn ignition switch OFF and wait at least 10 seconds.

>> GO TO 2.

#### 2. PERFORM DTC CONFIRMATION PROCEDURE

1. Turn ignition ON and wait at least 10 seconds.
2. Check DTC.

Is DTC detected?

- YES >> Proceed to [EC-176, "Diagnosis Procedure"](#).  
NO >> INSPECTION END

### Diagnosis Procedure

INFOID:000000011277927

#### 1. CHECK LIN COMMUNICATION CIRCUIT

1. Turn ignition switch OFF.
2. Disconnect ECM harness connector and generator harness connector.
3. Check the continuity between ECM harness connector and generator harness connector.

+		-		Continuity
ECM		Generator		
Connector	Terminal	Connector	Terminal	
F52	85	F31	2	Existed

4. Also check harness for short to power and short to ground.

Is the inspection result normal?

- YES >> GO TO 2.  
NO >> Repair or replace error-detected parts.

#### 2. REPLACE GENERATOR

1. Replace generator. Refer to [CHG-20, "Removal and Installation"](#).
2. Erase DTC.
3. Perform DTC confirmation procedure again. Refer to [EC-176, "DTC Description"](#).



# U1044 ENG COMM CIRCUIT

< DTC/CIRCUIT DIAGNOSIS >

[QR25DE]

Is DTC detected again?

YES >> Replace ECM. Refer to [EC-502, "Removal and Installation"](#).

NO >> INSPECTION END

A

EC

C

D

E

F

G

H

I

J

K

L

M

N

O

P

# U1050, U1051 LIN COMMUNICATION

< DTC/CIRCUIT DIAGNOSIS >

[QR25DE]

## U1050, U1051 LIN COMMUNICATION

### DTC Description

INFOID:000000011277928

### DTC DETECTION LOGIC

DTC No.	CONSULT screen terms (Trouble diagnosis content)	DTC detecting condition
U1050	LIN COMMUNICATION [LIN (Local Interconnect Network) commu- nication)]	ECM detects LIN communication error.
U1051		

### POSSIBLE CAUSE

- Harness or connectors  
(LIN communication circuit is open or shorted.)
- Generator
- ECM

### FAIL-SAFE

Not applicable

### DTC CONFIRMATION PROCEDURE

#### 1.PRECONDITIONING

If DTC Confirmation Procedure has been previously conducted, always perform the following procedure before conducting the next test.

1. Turn ignition switch OFF and wait at least 10 seconds.
2. Turn ignition switch ON.
3. Turn ignition switch OFF and wait at least 10 seconds.

>> GO TO 2.

#### 2.PERFORM DTC CONFIRMATION PROCEDURE

1. Turn ignition ON and wait at least 10 seconds.
2. Check DTC.

#### Is DTC detected?

- YES >> Proceed to [EC-178, "Diagnosis Procedure"](#).  
NO >> INSPECTION END

### Diagnosis Procedure

INFOID:000000011277929

#### 1.CHECK LIN COMMUNICATION CIRCUIT

1. Turn ignition switch OFF.
2. Disconnect ECM harness connector and generator harness connector.
3. Check the continuity between ECM harness connector and generator harness connector.

+		-		Continuity
ECM		Generator		
Connector	Terminal	Connector	Terminal	
F52	85	F31	2	Existed

4. Also check harness for short to power and short to ground.

#### Is the inspection result normal?

- YES >> GO TO 2.  
NO >> Repair or replace error-detected parts.

#### 2.REPLACE GENERATOR

1. Replace generator. Refer to [CHG-20, "Removal and Installation"](#).

# U1050, U1051 LIN COMMUNICATION

[QR25DE]

< DTC/CIRCUIT DIAGNOSIS >

2. Erase DTC.
3. Perform DTC confirmation procedure again. Refer to [EC-178, "DTC Description"](#).

Is DTC detected again?

- YES >> Replace ECM. Refer to [EC-502, "Removal and Installation"](#).  
NO >> INSPECTION END

A

EC

C

D

E

F

G

H

I

J

K

L

M

N

O

P

P0011 IVT CONTROL

DTC Description

INFOID:000000011277930

DTC DETECTION LOGIC

DTC No.	CONSULT screen terms (Trouble diagnosis content)	DTC detecting condition
P0011	INT/V TIM CONT-B1 ("A" Camshaft position - timing over-advanced or system performance bank 1)	There is a gap between angle of target and phase-control angle degree.

POSSIBLE CAUSE

- Crankshaft position sensor (POS)
- Camshaft position sensor (PHASE)
- Intake valve control solenoid valve
- Accumulation of debris to the signal pick-up portion of the camshaft
- Timing chain installation
- Foreign matter caught in the oil groove for intake valve timing control

FAIL-SAFE

- Device fix mode
- ECM activates the IVT intermediate lock control solenoid valve to bring the cam sprocket into an intermediate lock condition.

DTC CONFIRMATION PROCEDURE

1. CHECK DTC PRIORITY

If DTC P0011 is displayed with DTC P0075, first perform the trouble diagnosis for DTC P0075.

Is applicable DTC detected?

- YES >> Perform diagnosis of applicable. Refer to [EC-194. "DTC Description"](#).
- NO >> GO TO 2.

2. PRECONDITIONING

If DTC Confirmation Procedure has been previously conducted, always perform the following procedure before conducting the next test.

1. Turn ignition switch OFF and wait at least 10 seconds.
2. Turn ignition switch ON.
3. Turn ignition switch OFF and wait at least 10 seconds.

**TESTING CONDITION:**

**Before performing the following procedure, confirm that battery voltage is between 11 V and 16 V at idle.**

>> GO TO 3.

3. PERFORM DTC CONFIRMATION PROCEDURE-1

 With CONSULT

1. Turn ignition switch ON and select "DATA MONITOR" mode of "ENGINE" using CONSULT.
2. Start engine and warm it up to normal operating temperature.
3. Maintain the following conditions for at least 13 consecutive seconds. Hold the accelerator pedal as steady as possible.

ENG SPEED	1,200 - 2,000 rpm
COOLAN TEMP/S	More than 60°C (140°F)
Selector lever	P or N position

4. Stop vehicle with engine running and let engine idle for 13 seconds.
5. Check 1st trip DTC.

 With GST

< DTC/CIRCUIT DIAGNOSIS >

Follow the procedure "With CONSULT" above.

Is 1st trip DTC detected?

- YES >> Proceed to [EC-181, "Diagnosis Procedure"](#).
- NO >> GO TO 4.

4.PERFORM DTC CONFIRMATION PROCEDURE-2

 With CONSULT

1. Maintain the following conditions for at least 20 consecutive seconds.

ENG SPEED	1,200 - 3,175 rpm (A constant rotation is maintained.)
COOLAN TEMP/S	More than 60°C (140°F)
Selector lever	D position
Driving location	Driving vehicle uphill (Increased engine load will help maintain the driving conditions required for this test.)

**CAUTION:**

**Always drive at a safe speed.**

2. Check 1st trip DTC.

 With GST

Follow the procedure "With CONSULT" above.

Is 1st trip DTC detected?

- YES >> Proceed to [EC-181, "Diagnosis Procedure"](#).
- NO >> INSPECTION END

Diagnosis Procedure

INFOID:000000011277931

1.CHECK DTC PRIORITY

If DTC P0011 is displayed with DTC P0075, first perform the trouble diagnosis for DTC P0075.

Is applicable DTC detected?

- YES >> Perform diagnosis of applicable. Refer to [EC-194, "DTC Description"](#).
- NO >> GO TO 2.

2.CHECK OIL PRESSURE WARNING LAMP

1. Start engine.
2. Check oil pressure warning lamp and confirm it is not illuminated.

Is oil pressure warning lamp illuminated?

- YES >> Check the engine oil level. Refer to [LU-7, "Inspection"](#).
- NO >> GO TO 3.

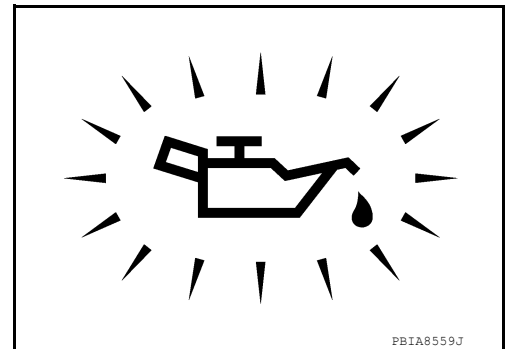

3.CHECK INTAKE VALVE TIMING CONTROL SOLENOID VALVE

Check the intake valve timing control solenoid valve. Refer to [EC-182, "Component Inspection"](#).

Is the inspection result normal?

- YES >> GO TO 4.
- NO >> Replace intake valve timing control solenoid valve. Refer to [EM-49, "Exploded View"](#).

4.CHECK CRANKSHAFT POSITION SENSOR (POS)

Check the crankshaft position sensor (POS). Refer to [EC-300, "Component Inspection \(Crankshaft Position sensor\)"](#).

Is the inspection result normal?

A  
EC  
C  
D  
E  
F  
G  
H  
I  
J  
K  
L  
M  
N  
O  
P

# P0011 IVT CONTROL

[QR25DE]

## < DTC/CIRCUIT DIAGNOSIS >

- YES >> GO TO 5.  
NO >> Replace crankshaft position sensor (POS). Refer to [EM-97, "Exploded View"](#).

### 5. CHECK CAMSHAFT POSITION SENSOR (PHASE)

Check the camshaft position sensor (PHASE). Refer to [EC-303, "Component Inspection \(Camshaft position sensor\)"](#).

Is the inspection result normal?

- YES >> GO TO 6.  
NO >> Replace camshaft position sensor (PHASE). Refer to [EM-69, "Exploded View"](#).

### 6. CHECK CAMSHAFT (INT)

Check the following.

- Accumulation of debris to the signal plate of camshaft rear end
- Chipping signal plate of camshaft rear end

Is the inspection result normal?

- YES >> GO TO 7.  
NO >> Remove debris and clean the signal plate of camshaft rear end or replace camshaft. Refer to [EM-69, "Removal and Installation"](#).

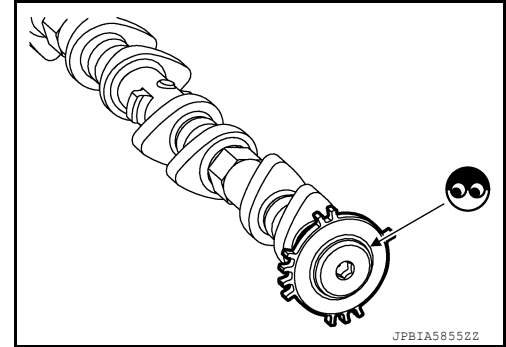

### 7. CHECK TIMING CHAIN INSTALLATION

Check service records for any recent repairs that may cause timing chain misaligned.

Are there any service records that may cause timing chain misaligned?

- YES >> Check timing chain installation. Refer to [EM-50, "Removal and Installation"](#).  
NO >> GO TO 8.

### 8. CHECK LUBRICATION CIRCUIT

Refer to [LU-7, "Inspection"](#), "INSPECTION AFTER INSTALLATION".

Is the inspection result normal?

- YES >> GO TO 9.  
NO >> Clean lubrication line.

### 9. CHECK INTERMITTENT INCIDENT

Refer to [GI-44, "Intermittent Incident"](#).

>> INSPECTION END

## Component Inspection

INFOID:0000000011277932

### 1. CHECK INTAKE VALVE TIMING CONTROL SOLENOID VALVE-1

1. Turn ignition switch OFF.
2. Disconnect intake valve timing control solenoid valve harness connector.
3. Check resistance between intake valve timing control solenoid valve terminals as per the following.

Intake valve timing control solenoid valve		Resistance
+	-	
Terminal		
1	2	6.7 - 7.7 $\Omega$ [at 20°C (68°F)]
1	Ground	$\infty \Omega$
2		(Continuity should not exist)

Is the inspection result normal?

# P0011 IVT CONTROL

[QR25DE]

## < DTC/CIRCUIT DIAGNOSIS >

YES >> GO TO 2.

NO >> Replace intake valve timing control solenoid valve. Refer to [EM-49, "Exploded View"](#).

### 2. CHECK INTAKE VALVE TIMING CONTROL SOLENOID VALVE-2

1. Remove intake valve timing control solenoid valve. Refer to [EM-49, "Exploded View"](#).

2. Provide 12 V DC between intake valve timing control solenoid valve terminals 1 and 2, and then interrupt it. Make sure that the plunger moves as shown in the figure.

**CAUTION:**

**Do not apply 12 V DC continuously for 5 seconds or more. Doing so may result in damage to the coil in intake valve timing control solenoid valve.**

**NOTE:**

**Always replace O-ring when intake valve timing control solenoid valve is removed.**

Is the inspection result normal?

YES >> INSPECTION END

NO >> Replace intake valve timing control solenoid valve. Refer to [EM-49, "Exploded View"](#).

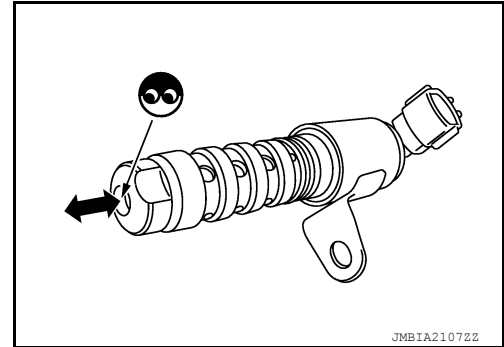

A  
EC  
C  
D  
E  
F  
G  
H  
I  
J  
K  
L  
M  
N  
O  
P

P0014 EVT CONTROL

DTC Description

INFOID:000000011277933

DTC DETECTION LOGIC

DTC No.	CONSULT screen terms (Trouble diagnosis content)	DTC detecting condition
P0014	EXH/V TIM CONT-B1 ("B" Camshaft position - timing over-advanced or system performance bank 1)	There is a gap between angle of target and phase-control angle degree.

POSSIBLE CAUSE

- Crankshaft position sensor (POS)
- Camshaft position sensor (PHASE)
- Exhaust valve timing control position sensor
- Exhaust valve control solenoid valve
- Accumulation of debris to the signal pick-up portion of the camshaft
- Timing chain installation
- Foreign matter caught in the oil groove for exhaust valve timing control

FAIL-SAFE

Device fix mode

DTC CONFIRMATION PROCEDURE

1. CHECK DTC PRIORITY

If DTC P0014 is displayed with DTC P0078 or P1078, first perform the trouble diagnosis for DTC P0078 or P1078.

Is applicable DTC detected?

- YES >> Perform diagnosis of applicable. Refer to [EC-96. "DTC Index"](#).
- NO >> GO TO 2.

2. PRECONDITIONING

If DTC Confirmation Procedure has been previously conducted, always perform the following procedure before conducting the next test.

1. Turn ignition switch OFF and wait at least 10 seconds.
2. Turn ignition switch ON.
3. Turn ignition switch OFF and wait at least 10 seconds.

TESTING CONDITION:

Before performing the following procedure, confirm that battery voltage is between 10 V and 16 V at idle.

>> GO TO 3.

3. PERFORM DTC CONFIRMATION PROCEDURE-1

 With CONSULT

1. Turn ignition switch ON and select "DATA MONITOR" mode of "ENGINE" using CONSULT.
2. Start engine and warm it up to the normal operating temperature.
3. Maintain the following conditions for at least 6 consecutive seconds. Hold the accelerator pedal as steady as possible.

ENG SPEED	1,200 - 2,000 rpm (A constant rotation is maintained.)
COOLAN TEMP/S	More than 60°C (140°F)
Selector lever	P or N position

4. Let engine idle for 10 seconds.
5. Check 1st trip DTC.

 With GST



# P0014 EVT CONTROL

[QR25DE]

< DTC/CIRCUIT DIAGNOSIS >

Follow the procedure "With CONSULT" above.

Is 1st trip DTC detected?

- YES >> Proceed to [EC-185. "Diagnosis Procedure"](#)
- NO >> GO TO 4.

## 4.PERFORM DTC CONFIRMATION PROCEDURE-2

 With CONSULT

1. Select "DATA MONITOR" mode of "ENGINE" using CONSULT.
2. Maintain the following conditions for at least 20 consecutive seconds.

ENG SPEED	1,700 - 2,950 rpm (A constant rotation is maintained.)
COOLAN TEMP/S	More than 70°C (158°F)
Selector lever	D position
Driving location uphill	Driving vehicle uphill (Increased engine load will help maintain the driving conditions required for this test.)

### CAUTION:

**Always drive at a safe speed.**

3. Check 1st trip DTC.

 With GST

Follow the procedure "With CONSULT" above.

Is 1st trip DTC detected?

- YES >> Proceed to [EC-185. "Diagnosis Procedure"](#)
- NO >> INSPECTION END

## Diagnosis Procedure

INFOID:0000000011277934

### 1.CHECK DTC PRIORITY

If DTC P0014 is displayed with DTC P0078 or P1078, first perform the trouble diagnosis for DTC P0078 or P1078.

Is applicable DTC detected?

- YES >> Perform diagnosis of applicable. Refer to [EC-96. "DTC Index"](#).
- NO >> GO TO 2.

### 2.CHECK OIL PRESSURE WARNING LAMP

1. Start engine.
2. Check oil pressure warning lamp and confirm it is not illuminated.

Is oil pressure warning lamp illuminated?

- YES >> Check the engine oil level. Refer to [LU-7. "Inspection"](#).
- NO >> GO TO 3.

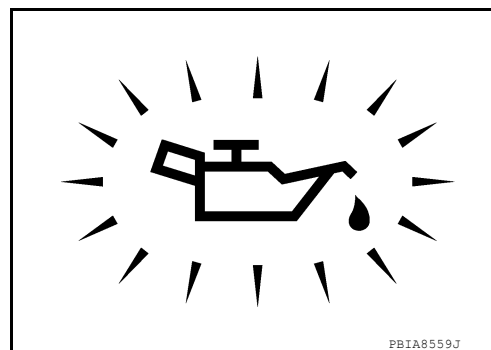

### 3.CHECK EXHAUST VALVE TIMING CONTROL SOLENOID VALVE

Check the exhaust valve timing control solenoid valve. Refer to [EC-182. "Component Inspection"](#).

Is the inspection result normal?

- YES >> GO TO 4.
- NO >> Replace exhaust valve timing control solenoid valve. Refer to [EM-49. "Exploded View"](#).

### 4.CHECK CRANKSHAFT POSITION SENSOR (POS)

# P0014 EVT CONTROL

[QR25DE]

## < DTC/CIRCUIT DIAGNOSIS >

Check the crankshaft position sensor (POS). Refer to [EC-300, "Component Inspection \(Crankshaft Position sensor\)"](#).

Is the inspection result normal?

YES >> GO TO 5.

NO >> Replace crankshaft position sensor (POS). Refer to [EM-97, "Exploded View"](#).

### 5.CHECK EXHAUST VALVE TIMING CONTROL POSITION SENSOR

Check the exhaust valve timing control position sensor. Refer to [EC-390, "Component Inspection"](#).

Is the inspection result normal?

YES >> GO TO 6.

NO >> Replace exhaust valve timing control position sensor. Refer to [EM-49, "Exploded View"](#).

### 6.CHECK CAMSHAFT (EXH)

Check the following.

- Accumulation of debris to the signal plate of camshaft rear end
- Chipping signal plate of camshaft rear end

Is the inspection result normal?

YES >> GO TO 7.

NO >> Remove debris and clean the signal plate of camshaft rear end or replace camshaft. Refer to [EM-69, "Removal and Installation"](#).

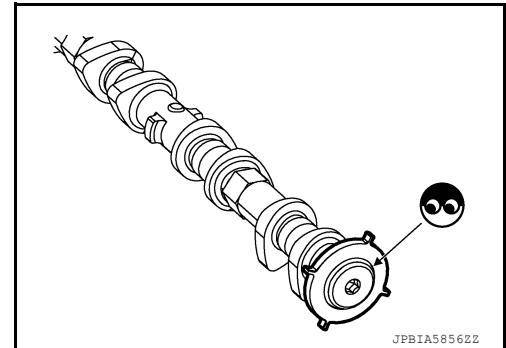

### 7.CHECK TIMING CHAIN INSTALLATION

Check service records for any recent repairs that may cause timing chain misaligned.

Are there any service records that may cause timing chain misaligned?

YES >> Check timing chain installation. Refer to [EM-50, "Removal and Installation"](#).

NO >> GO TO 8.

### 8.CHECK LUBRICATION CIRCUIT

Refer to [LU-7, "Inspection"](#).

Is the inspection result normal?

YES >> GO TO 9.

NO >> Clean lubrication line.

### 9.CHECK INTERMITTENT INCIDENT

Refer to [GI-44, "Intermittent Incident"](#).

>> INSPECTION END

## Component Inspection

INFOID:0000000011277935

### 1.CHECK EXHAUST VALVE TIMING CONTROL SOLENOID VALVE-1

1. Turn ignition switch OFF.
2. Disconnect exhaust valve timing control solenoid valve harness connector.
3. Check resistance between exhaust valve timing control solenoid valve terminals as per the following.

Exhaust valve timing control solenoid valve		Resistance
+	-	
Terminal		
1	2	7.0 - 7.7 $\Omega$ [at 20°C (68°F)]

# P0014 EVT CONTROL

[QR25DE]

## < DTC/CIRCUIT DIAGNOSIS >

Exhaust valve timing control solenoid valve		Resistance
+	-	
Terminal		
1	Ground	$\infty \Omega$ (Continuity should not exist)
2		

Is the inspection result normal?

YES >> GO TO 2.

NO >> Replace exhaust valve timing control solenoid valve. Refer to [EM-49, "Exploded View"](#).

## 2. CHECK EXHAUST VALVE TIMING CONTROL SOLENOID VALVE-2

1. Remove exhaust valve timing control solenoid valve. Refer to [EM-49, "Exploded View"](#).

2. Provide 12 V DC between exhaust valve timing control solenoid valve terminals 1 and 2, and then interrupt it. Check that the plunger moves as shown in the figure.

**CAUTION:**

**Do not apply 12 V DC continuously for 5 seconds or more. Doing so may result in damage to the coil in exhaust valve timing control solenoid valve.**

**NOTE:**

**Always replace O-ring when exhaust valve timing control solenoid valve is removed.**

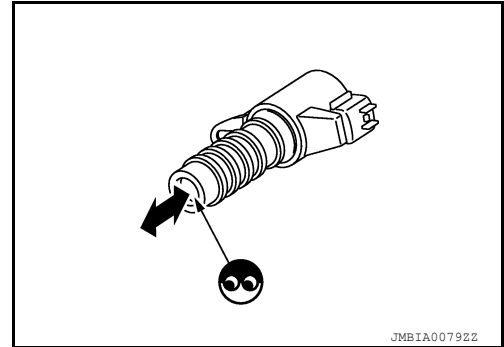

Is the inspection result normal?

YES >> INSPECTION END

NO >> Replace exhaust valve timing control solenoid valve. Refer to [EM-49, "Exploded View"](#).

# P0030, P0031, P0032 A/F SENSOR 1 HEATER

< DTC/CIRCUIT DIAGNOSIS >

[QR25DE]

## P0030, P0031, P0032 A/F SENSOR 1 HEATER

### DTC Description

INFOID:000000011277936

### DTC DETECTION LOGIC

DTC No.	CONSULT screen terms (Trouble diagnosis content)	DTC detecting condition
P0030	A/F SEN1 HTR (B1) [Air fuel ratio (A/F) sensor 1 heater (bank 1)performance]	Deterioration in A/F sensor 1 heater performance. (Voltage signal transmitted from A/F sensor 1 heater to ECM is higher/lower than voltage in the normal range .)
P0031	A/F SEN1 HTR (B1) [Air fuel ratio (A/F) sensor 1 heater (bank 1)control circuit low]	The current amperage in the A/F sensor 1 heater circuit is out of the normal range. (An excessively low voltage signal is sent to ECM through the A/F sensor 1 heater.)
P0032	A/F SEN1 HTR (B1) [Air fuel ratio (A/F) sensor 1 heater (bank 1)control circuit high]	The current amperage in the A/F sensor 1 heater circuit is out of the normal range. (An excessively high voltage signal is sent to ECM through the A/F sensor 1 heater.)

### POSSIBLE CAUSE

DTC P0030, P0031

- Harness or connectors (A/F sensor 1 heater circuit is open or shorted.)
- A/F sensor 1 heater

DTC P0032

- Harness or connectors (A/F sensor 1 heater circuit is shorted.)
- A/F sensor 1 heater

### FAIL-SAFE

Not applicable

### DTC CONFIRMATION PROCEDURE

#### 1.PRECONDITIONING

If DTC Confirmation Procedure has been previously conducted, always perform the following procedure before conducting the next test.

1. Turn ignition switch OFF and wait at least 10 seconds.
2. Turn ignition switch ON.
3. Turn ignition switch OFF and wait at least 10 seconds.

#### TESTING CONDITION:

**Before performing the following procedure, confirm that battery voltage is more than between 11 V at idle.**

>> GO TO 2.

#### 2.PERFORM DTC CONFIRMATION PROCEDURE

1. Start engine and let it idle for at least 10 seconds.
2. Check 1st trip DTC.

Is 1st trip DTC detected?

- YES >> Proceed to [EC-188, "Diagnosis Procedure"](#).  
NO >> INSPECTION END

### Diagnosis Procedure

INFOID:000000011277937

#### 1.CHECK AIR FUEL RATIO (A/F) SENSOR 1 POWER SUPPLY CIRCUIT

1. Disconnect air fuel ratio (A/F) sensor 1 harness connector.
2. Turn ignition switch ON.
3. Check the voltage between A/F sensor 1 harness connector and ground.

# P0030, P0031, P0032 A/F SENSOR 1 HEATER

< DTC/CIRCUIT DIAGNOSIS >

[QR25DE]

+		-	Voltage
A/F sensor 1			
Connector	Terminal		
F18	4	Ground	Battery voltage

Is the inspection result normal?

YES >> GO TO 2.

NO >> Repair or replace error-detected parts.

## 2. CHECK A/F SENSOR 1 HEATER OUTPUT SIGNAL CIRCUIT

1. Turn ignition switch OFF.
2. Disconnect ECM harness connector.
3. Check the continuity between A/F sensor 1 harness connector and ECM harness connector.

+		-		Continuity
A/F sensor 1		ECM		
Connector	Terminal	Connector	Terminal	
F18	3	F52	53	Existed

4. Also check harness for short to ground and to power.

Is the inspection result normal?

YES >> GO TO 3.

NO >> Repair open circuit, short to ground or short to power in harness or connectors.

## 3. CHECK A/F SENSOR 1 HEATER

Check the A/F sensor 1 heater. Refer to [EC-189, "Component Inspection"](#).

Is the inspection result normal?

YES >> GO TO 5.

NO >> GO TO 4.

## 4. REPLACE AIR FUEL RATIO (A/F) SENSOR 1

Replace malfunctioning air fuel ratio (A/F) sensor 1. Refer to [EM-32, "Exploded View"](#).

### CAUTION:

- Discard any A/F sensor which has been dropped from a height of more than 0.5 m (19.7 in) onto a hard surface such as a concrete floor; use a new one.
- Before installing new A/F sensor, clean exhaust system threads using Oxygen Sensor Thread Cleaner [commercial service tool (J-43897-18 or J-43897-12)] and approved Anti-seize Lubricant (commercial service tool).

>> INSPECTION END

## 5. CHECK INTERMITTENT INCIDENT

Refer to [GI-44, "Intermittent Incident"](#).

>> INSPECTION END

## Component Inspection

INFOID:000000011277938

## 1. CHECK AIR FUEL RATIO (A/F) SENSOR 1

1. Turn ignition switch OFF.
2. Disconnect A/F sensor 1 harness connector.
3. Check resistance between A/F sensor 1 terminals as per the following.

# P0030, P0031, P0032 A/F SENSOR 1 HEATER

< DTC/CIRCUIT DIAGNOSIS >

[QR25DE]

A/F sensor 1		Resistance
+	-	
Terminal		
3	4	1.8 - 2.44 $\Omega$ [at 20°C (68°F)]
	1	$\infty \Omega$ (Continuity should not exist)
	2	
4		
4	1	
	2	

Is the inspection result normal?

YES >> INSPECTION END

NO >> GO TO 2.

## 2. REPLACE AIR FUEL RATIO (A/F) SENSOR 1

Replace air fuel ratio (A/F) sensor 1. Refer to [EM-32. "Exploded View"](#).

### CAUTION:

- Discard any sensor which has been dropped from a height of more than 0.5 m (19.7 in) onto a hard surface such as a concrete floor; use a new one.
- Before installing new sensor, clean exhaust system threads using Oxygen Sensor Thread Cleaner [commercial service tool (J-43897-18 or J43897-12)] and approved Anti-seize Lubricant (commercial service tool).

>> INSPECTION END

# P0037, P0038 HO2S2 HEATER

< DTC/CIRCUIT DIAGNOSIS >

[QR25DE]

## P0037, P0038 HO2S2 HEATER

### DTC Description

INFOID:000000011277939

### DTC DETECTION LOGIC

DTC No.	CONSULT screen terms (Trouble diagnosis content)	DTC detecting condition
P0037	HO2S2 HTR (B1) (HO2S heater control circuit low bank 1 sensor 2)	The current amperage in the heated oxygen sensor 2 heater circuit is out of the normal range. (An excessively low voltage signal is sent to ECM through the heated oxygen sensor 2 heater.)
P0038	HO2S2 HTR (B1) (HO2S heater control circuit high bank 1 sensor 2)	The current amperage in the heated oxygen sensor 2 heater circuit is out of the normal range. (An excessively high voltage signal is sent to ECM through the heated oxygen sensor 2 heater.)

### POSSIBLE CAUSE

#### DTC P0037

- Harness or connectors (Heated oxygen sensor 2 heater circuit is open or shorted.)
- Heated oxygen sensor 2 heater

#### DTC P0038

- Harness or connectors (Heated oxygen sensor 2 heater circuit is shorted.)
- Heated oxygen sensor 2 heater

#### FAIL-SAFE

Not applicable

### DTC CONFIRMATION PROCEDURE

#### 1. PRECONDITIONING

If DTC Confirmation Procedure has been previously conducted, always perform the following procedure before conducting the next test.

1. Turn ignition switch OFF and wait at least 10 seconds.
2. Turn ignition switch ON.
3. Turn ignition switch OFF and wait at least 10 seconds.

#### TESTING CONDITION:

**Before performing the following procedure, confirm that battery voltage is more than 11 V at idle.**

>> GO TO 2.

#### 2. PERFORM DTC CONFIRMATION PROCEDURE

##### With CONSULT

1. Turn ignition switch ON and select "DATA MONITOR" mode of "ENGINE" using CONSULT.
2. Start engine and warm it up to normal operating temperature.
3. Turn ignition switch OFF and wait at least 10 seconds.
4. Start engine and keep the engine speed between 3,500 and 4,000 rpm for at least 1 minute under no load.
5. Let engine idle for 1 minute.
6. Check 1st trip DTC.

##### With GST

Follow the procedure "With CONSULT" above.

#### Is 1st trip DTC detected?

- YES >> Proceed to [EC-191, "Diagnosis Procedure"](#).  
NO >> INSPECTION END

### Diagnosis Procedure

INFOID:000000011277940

#### 1. CHECK HO2S2 POWER SUPPLY CIRCUIT

# P0037, P0038 HO2S2 HEATER

[QR25DE]

## < DTC/CIRCUIT DIAGNOSIS >

1. Turn ignition switch OFF.
2. Disconnect heated oxygen sensor 2 (HO2S2) harness connector.
3. Turn ignition switch ON.
4. Check the voltage between HO2S2 harness connector and ground.

+		-	Voltage
HO2S2			
Connector	Terminal		
F21	4	Ground	Battery voltage

### Is the inspection result normal?

YES >> GO TO 2.

NO >> Repair or replace error-detected parts.

## 2. CHECK HO2S2 OUTPUT SIGNAL CIRCUIT

1. Turn ignition switch OFF.
2. Disconnect ECM harness connector.
3. Check the continuity between HO2S2 harness connector and ECM harness connector.

+		-		Continuity
HO2S2		ECM		
Connector	Terminal	Connector	Terminal	
F21	3	F52	54	Existed

4. Also check harness for short to ground and to power.

### Is the inspection result normal?

YES >> GO TO 3.

NO >> Repair or replace error-detected parts.

## 3. CHECK HEATED OXYGEN SENSOR 2 HEATER

Check the heated oxygen sensor 2 heater. Refer to [EC-192, "Component Inspection"](#).

### Is the inspection result normal?

YES >> GO TO 5.

NO >> GO TO 4.

## 4. REPLACE HEATED OXYGEN SENSOR 2

Replace heated oxygen sensor 2. Refer to [EX-5, "Exploded View"](#).

### **CAUTION:**

- Discard any sensor which has been dropped from a height of more than 0.5 m (19.7 in) onto a hard surface such as a concrete floor; use a new one.
- Before installing new sensor, clean exhaust system threads using Oxygen Sensor Thread Cleaner [commercial service tool (J-43897-18 or J43897-12)] and approved Anti-seize Lubricant (commercial service tool).

>> INSPECTION END

## 5. CHECK INTERMITTENT INCIDENT

Refer to [GI-44, "Intermittent Incident"](#).

>> INSPECTION END

## Component Inspection

INFOID:0000000011277941

## 1. CHECK HEATED OXYGEN SENSOR 2 HEATER

1. Turn ignition switch OFF.
2. Disconnect heated oxygen sensor 2 (HO2S2) harness connector.
3. Check resistance between HO2S2 terminals as per the following.



# P0037, P0038 HO2S2 HEATER

< DTC/CIRCUIT DIAGNOSIS >

[QR25DE]

Heated oxygen sensor 2		Resistance
+	-	
Terminal		
4	3	3.3 - 4.4 Ω [at 25°C (77°F)]
1	2	∞ Ω (Continuity should not exist)
	3	
	4	
2	3	
	4	

Is the inspection result normal?

YES >> INSPECTION END

NO >> GO TO 2.

## 2. REPLACE HEATED OXYGEN SENSOR 2

Replace heated oxygen sensor 2. Refer to [EX-5. "Exploded View"](#).

### CAUTION:

- Discard any sensor which has been dropped from a height of more than 0.5 m (19.7 in) onto a hard surface such as a concrete floor; use a new one.
- Before installing new sensor, clean exhaust system threads using Oxygen Sensor Thread Cleaner [commercial service tool (J-43897-18 or J43897-12)] and approved Anti-seize Lubricant (commercial service tool).

>> INSPECTION END

A  
EC  
C  
D  
E  
F  
G  
H  
I  
J  
K  
L  
M  
N  
O  
P

# P0075 INTAKE VALVE TIMING CONTROL

< DTC/CIRCUIT DIAGNOSIS >

[QR25DE]

## P0075 INTAKE VALVE TIMING CONTROL

### DTC Description

INFOID:000000011277942

### DTC DETECTION LOGIC

DTC No.	CONSULT screen terms (Trouble diagnosis content)	DTC detecting condition
P0075	INT/V TIM V/CIR-B1 (Intake valve control solenoid circuit bank 1)	<ul style="list-style-type: none"><li>ECM detects an abnormal voltage in the intake valve timing control solenoid valve control circuit.</li><li>ECM detects an abnormal voltage in the intake valve timing intermediate lock control solenoid valve control circuit.</li></ul>

### POSSIBLE CAUSE

- Harness or connectors
- Intake valve timing control solenoid valve circuit is open or shorted.
- Intake valve timing intermediate lock control solenoid valve circuit is open or shorted.
- Intake valve timing control solenoid valve
- Intake valve timing intermediate lock control solenoid valve

### FAIL-SAFE

Not applicable

### DTC CONFIRMATION PROCEDURE

#### 1. PRECONDITIONING

If DTC Confirmation Procedure has been previously conducted, always perform the following procedure before conducting the next test.

1. Turn ignition switch OFF and wait at least 10 seconds.
2. Turn ignition switch ON.
3. Turn ignition switch OFF and wait at least 10 seconds.

>> GO TO 2.

#### 2. PERFORM DTC CONFIRMATION PROCEDURE

1. Start engine and let it idle for 5 seconds.
2. Check 1st trip DTC.

#### Is 1st trip DTC detected?

- YES >> Proceed to [EC-194, "Diagnosis Procedure"](#).  
NO >> INSPECTION END

### Diagnosis Procedure

INFOID:000000011277943

#### 1. CHECK INTAKE VALVE TIMING (IVT) CONTROL SOLENOID VALVE POWER SUPPLY

1. Turn ignition switch OFF.
2. Disconnect IVT control solenoid valve harness connector.
3. Turn ignition switch ON.
4. Check the voltage between intake valve timing control solenoid valve harness connector and ground.

+		-	Voltage
IVT control solenoid valve Connector	Terminal		
F25	1	Ground	Battery voltage

#### Is the inspection result normal?

- YES >> GO TO 3.  
NO >> GO TO 2.

#### 2. CHECK IVT CONTROL SOLENOID VALVE POWER SUPPLY CIRCUIT

# P0075 INTAKE VALVE TIMING CONTROL

[QR25DE]

## < DTC/CIRCUIT DIAGNOSIS >

1. Turn ignition switch OFF.
2. Disconnect IPDM E/R harness connector.
3. Check the continuity between IVT control solenoid valve harness connector and IPDM E/R harness connector.

+		-		Continuity
IVT control solenoid valve		IPDM E/R		
Connector	Terminal	Connector	Terminal	
F25	1	F35	78	Existed

4. Also check harness for short to ground.

### Is the inspection result normal?

- YES >> Perform the trouble diagnosis for power supply circuit.  
 NO >> Repair or replace error-detected parts.

## 3.CHECK IVT CONTROL SOLENOID VALVE GROUND CIRCUIT

1. Turn ignition switch OFF.
2. Disconnect ECM harness connector.
3. Check the continuity between IVT control solenoid valve harness connector and ECM harness connector.

+		-		Continuity
IVT control solenoid valve		ECM		
Connector	Terminal	Connector	Terminal	
F25	2	F52	93	Existed

4. Also check harness for short to ground and short to power.

### Is the inspection result normal?

- YES >> GO TO 4.  
 NO >> Repair or replace error-detected parts.

## 4.CHECK IVT CONTROL SOLENOID VALVE

Check the IVT control solenoid valve. Refer to [EC-196. "Component Inspection \(IVT Control Solenoid Valve\)"](#).

### Is the inspection result normal?

- YES >> GO TO 5.  
 NO >> Replace IVT control solenoid valve. Refer to [EM-49. "Exploded View"](#).

## 5.CHECK IVT INTERMEDIATE LOCK CONTROL SOLENOID VALVE POWER SUPPLY

1. Disconnect IVT intermediate lock control solenoid valve harness connector.
2. Turn ignition switch ON.
3. Check the voltage between IVT intermediate lock control solenoid valve harness connector and ground.

+		-	Voltage
IVT intermediate lock control solenoid valve			
Connector	Terminal		
F23	1	Ground	Battery voltage

### Is the inspection result normal?

- YES >> GO TO 7.  
 NO >> GO TO 6.

## 6.CHECK IVT INTERMEDIATE LOCK CONTROL SOLENOID VALVE POWER SUPPLY CIRCUIT

1. Turn ignition switch OFF.
2. Disconnect IPDM E/R harness connector.
3. Check the continuity between IVT intermediate lock control solenoid valve harness connector and IPDM E/R harness connector.

# P0075 INTAKE VALVE TIMING CONTROL

[QR25DE]

< DTC/CIRCUIT DIAGNOSIS >

+		-		Continuity
IVT intermediate lock control solenoid valve		IPDM E/R		
Connector	Terminal	Connector	Terminal	
F23	1	F35	78	Existed

4. Also check harness for short to ground.

Is the inspection result normal?

YES >> Perform the trouble diagnosis for power supply circuit.

NO >> Repair or replace error-detected parts.

## 7. CHECK IVT INTERMEDIATE LOCK CONTROL SOLENOID VALVE GROUND CIRCUIT

1. Turn ignition switch OFF.
2. Disconnect ECM harness connector.
3. Check the continuity between IVT intermediate lock control solenoid valve harness connector and ECM harness connector.

+		-		Continuity
IVT intermediate lock control solenoid valve		ECM		
Connector	Terminal	Connector	Terminal	
F23	2	F52	56	Existed

4. Also check harness for short to ground and short to power.

Is the inspection result normal?

YES >> GO TO 8.

NO >> Repair or replace error-detected parts.

## 8. CHECK IVT INTERMEDIATE LOCK CONTROL SOLENOID VALVE

Check the IVT intermediate lock control solenoid valve. Refer to [EC-197, "Component Inspection \(IVT Intermediate Lock Control Solenoid Valve\)"](#).

Is the inspection result normal?

YES >> GO TO 9.

NO >> Replace IVT intermediate lock control solenoid valve. Refer to [EM-69, "Exploded View"](#).

## 9. CHECK INTERMITTENT INCIDENT

Refer to [GI-44, "Intermittent Incident"](#).

>> INSPECTION END

## Component Inspection (IVT Control Solenoid Valve)

INFOID:000000011277944

### 1. CHECK INTAKE VALVE TIMING CONTROL SOLENOID VALVE-I

1. Turn ignition switch OFF.
2. Disconnect intake valve timing control solenoid valve harness connector.
3. Check resistance between intake valve timing control solenoid valve terminals as follows.

Terminals	Resistance
1 and 2	7.0 - 7.5 $\Omega$ [at 20°C (68°F)]
1 or 2 and ground	$\infty \Omega$ (Continuity should not exist)

Is the inspection result normal?

YES >> GO TO 2.

NO >> Replace intake valve timing control solenoid valve. Refer to [EM-49, "Exploded View"](#).

# P0075 INTAKE VALVE TIMING CONTROL

< DTC/CIRCUIT DIAGNOSIS >

[QR25DE]

## 2. CHECK INTAKE VALVE TIMING CONTROL SOLENOID VALVE-II

1. Remove intake valve timing control solenoid valve. Refer to [EM-49, "Exploded View"](#).
2. Provide 12 V DC between intake valve timing control solenoid valve terminals 1 and 2, and then interrupt it. Make sure that the plunger moves as shown in the figure.

**CAUTION:**

**Do not apply 12 V DC continuously for 5 seconds or more. Doing so may result in damage to the coil in intake valve timing control solenoid valve.**

**NOTE:**

**Always replace O-ring when intake valve timing control solenoid valve is removed.**

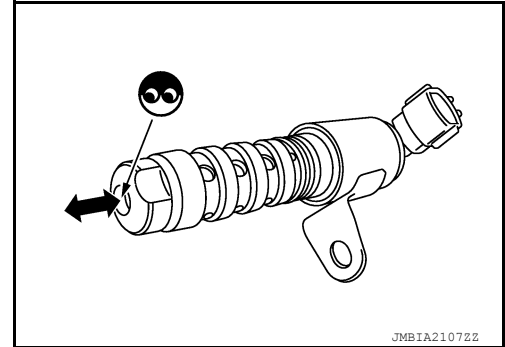

Is the inspection result normal?

YES >> INSPECTION END

NO >> Replace intake valve timing control solenoid valve. Refer to [EM-49, "Exploded View"](#).

## Component Inspection (IVT Intermediate Lock Control Solenoid Valve)

INFOID:000000011277945

### 1. CHECK INTAKE VALVE TIMING INTERMEDIATE LOCK CONTROL SOLENOID VALVE-I

1. Turn ignition switch OFF.
2. Disconnect intake valve timing intermediate lock control solenoid valve harness connector.
3. Check resistance between intake valve timing intermediate lock control solenoid valve terminals as follows.

Terminals	Resistance
1 and 2	7.0 - 7.5 $\Omega$ [at 20°C (68°F)]
1 or 2 and ground	$\infty \Omega$ (Continuity should not exist)

Is the inspection result normal?

YES >> GO TO 2.

NO >> Replace intake valve timing intermediate lock control solenoid valve. Refer to [EM-49, "Exploded View"](#).

### 2. CHECK INTAKE VALVE TIMING INTERMEDIATE LOCK CONTROL SOLENOID VALVE-II

1. Remove intake valve timing intermediate lock control solenoid valve. Refer to [EM-49, "Exploded View"](#).
2. Provide 12 V DC between intake valve timing intermediate lock control solenoid valve terminals 1 and 2, and then interrupt it. Make sure that the plunger moves as shown in the figure.

**CAUTION:**

**Do not apply 12 V DC continuously for 5 seconds or more. Doing so may result in damage to the coil in intake valve timing intermediate lock control solenoid valve.**

**NOTE:**

**Always replace O-ring when intake valve timing intermediate lock control solenoid valve is removed.**

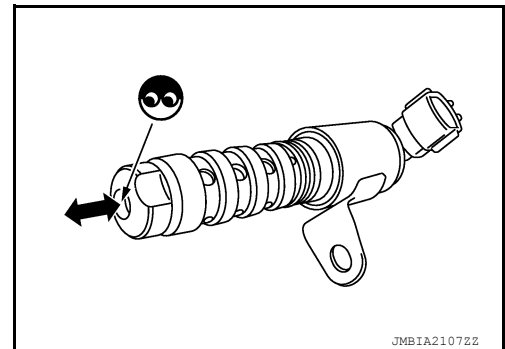

Is the inspection result normal?

YES >> INSPECTION END

NO >> Replace intake valve timing intermediate lock control solenoid valve. Refer to [EM-49, "Exploded View"](#).

# P0078 EVT CONTROL SOLENOID VALVE

< DTC/CIRCUIT DIAGNOSIS >

[QR25DE]

## P0078 EVT CONTROL SOLENOID VALVE

### DTC Description

INFOID:000000011277946

### DTC DETECTION LOGIC

DTC No.	CONSULT screen terms (Trouble diagnosis content)	DTC detecting condition
P0078	EX V/T ACT/CIRC-B1 (Exhaust valve control solenoid circuit bank 1)	An improper voltage is sent to the ECM through exhaust valve timing control solenoid valve.

### POSSIBLE CAUSE

- Harness or connectors (Exhaust valve timing control solenoid valve circuit is open or shorted.)
- Exhaust valve timing control solenoid valve

### FAIL-SAFE

Device fix mode

### DTC CONFIRMATION PROCEDURE

#### 1. PRECONDITIONING

If DTC Confirmation Procedure has been previously conducted, always perform the following procedure before conducting the next test.

1. Turn ignition switch OFF and wait at least 10 seconds.
2. Turn ignition switch ON.
3. Turn ignition switch OFF and wait at least 10 seconds.

>> GO TO 2.

#### 2. PERFORM DTC CONFIRMATION PROCEDURE

1. Start engine and let it idle for 5 seconds.
2. Check 1st trip DTC.

#### Is 1st trip DTC detected?

- YES >> Proceed to [EC-198, "Diagnosis Procedure"](#).  
NO >> INSPECTION END

### Diagnosis Procedure

INFOID:000000011277947

#### 1. CHECK EXHAUST VALVE TIMING CONTROL SOLENOID VALVE POWER SUPPLY

1. Turn ignition switch OFF.
2. Disconnect exhaust valve timing (EVT) control solenoid valve harness connector.
3. Turn ignition switch ON.
4. Check the voltage between exhaust valve timing control solenoid valve harness connector and ground.

+		-	Voltage
Connector	Terminal		
F24	1	Ground	Battery voltage

#### Is the inspection result normal?

- YES >> GO TO 3.  
NO >> GO TO 2.

#### 2. CHECK EXHAUST VALVE TIMING CONTROL SOLENOID VALVE POWER SUPPLY CIRCUIT

1. Turn ignition switch OFF.
2. Disconnect IPDM E/R harness connector.

# P0078 EVT CONTROL SOLENOID VALVE

[QR25DE]

## < DTC/CIRCUIT DIAGNOSIS >

3. Check the continuity between EVT control solenoid valve harness connector and IPDM E/R harness connector.

+		+		Continuity
EVT control solenoid valve		IPDM E/R		
Connector	Terminal	Connector	Terminal	
F24	1	F35	78	Existed

4. Also check harness for short to ground.

Is the inspection result normal?

- YES >> Perform the trouble diagnosis for power supply circuit.  
 NO >> Repair or replace error-detected parts.

### 3.CHECK EXHAUST VALVE TIMING CONTROL SOLENOID VALVE GROUND CIRCUIT

1. Turn ignition switch OFF.
2. Disconnect ECM harness connector.
3. Check the continuity between EVT control solenoid valve harness connector and ECM harness connector.

+		+		Continuity
EVT control solenoid valve		ECM		
Connector	Terminal	Connector	Terminal	
F24	2	F52	94	Existed

4. Also check harness for short to ground and to power.

Is the inspection result normal?

- YES >> GO TO 4.  
 NO >> Repair or replace error-detected parts.

### 4.CHECK EXHAUST VALVE TIMING CONTROL SOLENOID VALVE

Check the exhaust valve timing control solenoid valve. Refer to [EC-186, "Component Inspection"](#).

Is the inspection result normal?

- YES >> GO TO 5.  
 NO >> Replace exhaust valve timing control solenoid valve.

### 5.CHECK INTERMITTENT INCIDENT

Refer to [GI-44, "Intermittent Incident"](#).

>> INSPECTION END

## Component Inspection

INFOID:0000000011277948

### 1.CHECK EXHAUST VALVE TIMING CONTROL SOLENOID VALVE-1

1. Turn ignition switch OFF.
2. Disconnect exhaust valve timing control solenoid valve harness connector.
3. Check resistance between exhaust valve timing control solenoid valve terminals as per the following.

Exhaust valve timing control solenoid valve		Resistance
+	-	
Terminal		
1	2	7.0 - 7.7 Ω [at 20°C (68°F)]
1	Ground	∞ Ω (Continuity should not exist)
2		

Is the inspection result normal?

## P0078 EVT CONTROL SOLENOID VALVE

[QR25DE]

< DTC/CIRCUIT DIAGNOSIS >

YES >> GO TO 2.

NO >> Replace exhaust valve timing control solenoid valve. Refer to [EM-49. "Exploded View"](#).

### 2. CHECK EXHAUST VALVE TIMING CONTROL SOLENOID VALVE-2

1. Remove exhaust valve timing control solenoid valve. Refer to [EM-49. "Exploded View"](#).

2. Provide 12 V DC between exhaust valve timing control solenoid valve terminals 1 and 2, and then interrupt it. Check that the plunger moves as shown in the figure.

**CAUTION:**

**Do not apply 12 V DC continuously for 5 seconds or more. Doing so may result in damage to the coil in exhaust valve timing control solenoid valve.**

**NOTE:**

**Always replace O-ring when exhaust valve timing control solenoid valve is removed.**

Is the inspection result normal?

YES >> INSPECTION END

NO >> Replace exhaust valve timing control solenoid valve. Refer to [EM-49. "Exploded View"](#).

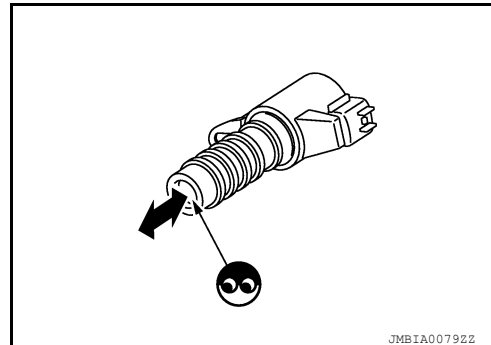



# P0101 MAF SENSOR

< DTC/CIRCUIT DIAGNOSIS >

[QR25DE]

## P0101 MAF SENSOR

### DTC Description

INFOID:0000000011277949

### DTC DETECTION LOGIC

DTC No.	CONSULT screen terms (Trouble diagnosis content)	DTC detecting condition
P0101	MAF SEN/CIRCUIT-B1 (Mass or volume air Flow "A" circuit range/ performance)	<ul style="list-style-type: none"><li>A high voltage from the sensor is sent to ECM under light load driving condition.</li><li>A low voltage from the sensor is sent to ECM under heavy load driving condition.</li></ul>

### POSSIBLE CAUSE

- Harness or connectors (MAF sensor circuit is open or shorted.)
- Intake air leaks
- MAF sensor
- EVAP control system pressure sensor
- Intake air temperature sensor
- Sensor power supply 2 circuit

### FAIL-SAFE

- Traveling control mode (Accelerator angle variation control)
- Traveling control mode (Engine output control)
- Device fix mode

### DTC CONFIRMATION PROCEDURE

#### 1. CHECK DTC PRIORITY

If DTC P0101 is displayed with other DTC, first perform the trouble diagnosis for other DTC.

#### Is applicable DTC detected?

- YES >> Perform diagnosis of applicable. Refer to [EC-96, "DTC Index"](#).  
NO >> GO TO 2.

#### 2. PRECONDITIONING

If DTC CONFIRMATION PROCEDURE has been previously conducted, always perform the following procedure before conducting the next test.

- Turn ignition switch OFF and wait at least 10 seconds.
- Turn ignition switch ON.
- Turn ignition switch OFF and wait at least 10 seconds.

>> GO TO 3.

#### 3. PERFORM DTC CONFIRMATION PROCEDURE

- Start engine and warm it up to normal operating temperature.
- Drive the vehicle for at least 5 seconds under the following conditions:

**CAUTION:**

**Always drive vehicle at safe speed.**

Selector lever	Suitable position
Vehicle speed	40 km/h (25 MPH) or more

**NOTE:**

- The gear must be fixed while driving the vehicle.
  - Keep the accelerator pedal as steady as possible during cruising.
- Check 1st trip DTC.

#### Is 1st trip DTC detected?

- YES >> Proceed to [EC-202, "Diagnosis Procedure"](#).  
NO >> INSPECTION END

# P0101 MAF SENSOR

[QR25DE]

< DTC/CIRCUIT DIAGNOSIS >

INFOID:000000011277950

## Diagnosis Procedure

### 1. CHECK DTC PRIORITY

If DTC P0101 is displayed with other DTC, first perform the trouble diagnosis for other DTC.

Is applicable DTC detected?

- YES >> Perform diagnosis of applicable. Refer to [EC-96. "DTC Index"](#).
- NO >> GO TO 2.

### 2. CHECK INTAKE SYSTEM

Check the following for connection.

- Air duct
- Vacuum hoses
- Intake air passage between air duct and intake manifold

Is the inspection result normal?

- YES >> GO TO 3.
- NO >> Reconnect the parts.

### 3. CHECK MASS AIR FLOW (MAF) SENSOR POWER SUPPLY

1. Turn ignition switch OFF.
2. Disconnect MAF sensor harness connector.
3. Turn ignition switch ON.
4. Check the voltage between MAF sensor harness connector and ground.

+		-	Voltage
MAF sensor			
Connector	Terminal		
F22	1	Ground	5 V

Is the inspection result normal?

- YES >> GO TO 5.
- NO >> GO TO 4.

### 4. CHECK SENSOR POWER SUPPLY 2 CIRCUIT

Perform [EC-487. "Diagnosis Procedure"](#).

Is the inspection result normal?

- YES >> Perform the trouble diagnosis for power supply circuit.
- NO >> Repair or replace error-detected parts.

### 5. CHECK MAF SENSOR GROUND CIRCUIT

1. Turn ignition switch OFF.
2. Disconnect ECM harness connector.
3. Check the continuity between MAF sensor harness connector and ECM harness connector.

+		-		Continuity
MAF sensor		ECM		
Connector	Terminal	Connector	Terminal	
F22	2	F51	34	Existed

4. Also check harness for short to power.

Is the inspection result normal?

- YES >> GO TO 6.
- NO >> Repair or replace error-detected parts.

### 6. CHECK MAF SENSOR INPUT SIGNAL CIRCUIT

1. Check the continuity between MAF sensor harness connector and ECM harness connector.

# P0101 MAF SENSOR

< DTC/CIRCUIT DIAGNOSIS >

[QR25DE]

+		-		Continuity
MAF sensor		ECM		
Connector	Terminal	Connector	Terminal	
F22	3	F51	35	Existed

2. Also check harness for short to ground and to power.

Is the inspection result normal?

YES >> GO TO 7.

NO >> Repair or replace error-detected parts

## 7.CHECK INTAKE AIR TEMPERATURE SENSOR

Check the intake air temperature sensor. Refer to [EC-210, "Component Inspection"](#).

Is the inspection result normal?

YES >> GO TO 8.

NO >> Replace MAF sensor (with intake air temperature sensor). Refer to [EM-26, "Exploded View"](#).

## 8.CHECK EVAP CONTROL SYSTEM PRESSURE SENSOR

Check the EVAP control system pressure sensor. Refer to [EC-333, "Component Inspection"](#).

Is the inspection result normal?

YES >> GO TO 9.

NO >> Replace EVAP control system pressure sensor. Refer to [FL-22, "Removal and Installation"](#).

## 9.CHECK MAF SENSOR

Check the MAF sensor. Refer to [EC-203, "Component Inspection"](#).

Is the inspection result normal?

YES >> GO TO 10.

NO >> Replace MAF sensor. Refer to [EM-26, "Exploded View"](#).

## 10.CHECK INTERMITTENT INCIDENT

Refer to [GI-44, "Intermittent Incident"](#).

>> INSPECTION END

## Component Inspection

INFOID:0000000011277951

### 1.CHECK MASS AIR FLOW SENSOR-1

 With CONSULT

1. Turn ignition switch OFF.
2. Reconnect all harness connectors disconnected.
3. Start engine and warm it up to normal operating temperature.
4. Connect CONSULT and select "DATA MONITOR" mode of "ENGINE".
5. Select "MASS AIR FLOW SENSOR (Hz)" and check indication.

Monitor item	Condition	Value
MASS AIR FLOW SENSOR (Hz)	Ignition switch ON (Engine stopped.)	Approx. 3500 Hz
	Idle (Engine is warmed-up to normal operating temperature.)	3500- 4100 Hz
	2,500 rpm (Engine is warmed-up to normal operating temperature.)	5000 - 5600 Hz
	Idle to about 4,000 rpm	3500 - 4100 Hz to Approx. 6300 Hz*

\*: Check for linear frequency rise in response to engine being increased to about 4,000 rpm.

Is the inspection result normal?

YES >> INSPECTION END

NO >> GO TO 2.

# P0101 MAF SENSOR

[QR25DE]

< DTC/CIRCUIT DIAGNOSIS >

## 2. CHECK FOR THE CAUSE OF UNEVEN AIR FLOW THROUGH MASS AIR FLOW SENSOR

1. Turn ignition switch OFF.
2. Check for the cause of uneven air flow through mass air flow sensor. Refer to the following.
  - Crushed air ducts
  - Malfunctioning seal of air cleaner element
  - Uneven dirt of air cleaner element
  - Intake valve deposits
  - Improper specification of intake air system parts

Is the inspection result normal?

YES >> GO TO 4.

NO >> GO TO 3.

## 3. CHECK MASS AIR FLOW SENSOR-2

④ With CONSULT

1. Repair or replace malfunctioning part.
2. Start engine and warm it up to normal operating temperature.
3. Connect CONSULT and select "DATA MONITOR" mode of "ENGINE".
4. Select "MASS AIR FLOW SENSOR (Hz)" and check indication.

Monitor item	Condition	Value
MASS AIR FLOWSENSOR (Hz)	Ignition switch ON (Engine stopped.)	Approx. 3500 Hz
	Idle (Engine is warmed-up to normal operating temperature.)	3500- 4100 Hz
	2,500 rpm (Engine is warmed-up to normal operating temperature.)	5000 - 5600 Hz
	Idle to about 4,000 rpm	3500 - 4100 Hz to Approx. 6300 Hz*

\*: Check for linear frequency rise in response to engine being increased to about 4,000 rpm.

Is the inspection result normal?

YES >> INSPECTION END

NO >> GO TO 4.

## 4. CHECK MASS AIR FLOW SENSOR-3

④ With CONSULT

1. Turn ignition switch OFF.
2. Disconnect mass air flow sensor harness connector and reconnect it again.
3. Start engine and warm it up to normal operating temperature.
4. Connect CONSULT and select "DATA MONITOR" mode of "ENGINE".
5. Select "MASS AIR FLOW SENSOR (Hz)" and check indication.

Monitor item	Condition	Value
MASS AIR FLOWSENSOR (Hz)	Ignition switch ON (Engine stopped.)	Approx. 3500 Hz
	Idle (Engine is warmed-up to normal operating temperature.)	3500- 4100 Hz
	2,500 rpm (Engine is warmed-up to normal operating temperature.)	5000 - 5600 Hz
	Idle to about 4,000 rpm	3500 - 4100 Hz to Approx. 6300 Hz*

\*: Check for linear frequency rise in response to engine being increased to about 4,000 rpm.

Is the inspection result normal?

YES >> INSPECTION END

NO >> Clean or replace mass air flow sensor. Refer to [EM-26. "Exploded View"](#).

# P0102, P0103 MAF SENSOR

< DTC/CIRCUIT DIAGNOSIS >

[QR25DE]

## P0102, P0103 MAF SENSOR

### DTC Description

INFOID:0000000011277952

### DTC DETECTION LOGIC

DTC No.	CONSULT screen terms (Trouble diagnosis content)	DTC detecting condition
P0102	MAF SEN/CIRCUIT-B1 (Mass or volume air flow "A" circuit low)	An excessively low voltage from the mass air flow sensor is sent to ECM.
P0103	MAF SEN/CIRCUIT-B1 (Mass or volume air flow "A" circuit high)	An excessively high voltage from the mass air flow sensor is sent to ECM.

### POSSIBLE CAUSE

#### DTC P0102

- Harness or connectors (Mass air flow sensor circuit is open or shorted.)
- Intake air leaks
- Mass air flow sensor
- Sensor power supply 2 circuit

#### DTC P0103

- Harness or connectors (Mass air flow sensor circuit is open or shorted.)
- Mass air flow sensor
- Sensor power supply 2 circuit

### FAIL-SAFE

- Traveling control mode (Accelerator angle variation control)
- Traveling control mode (Engine output control)
- Device fix mode

### DTC CONFIRMATION PROCEDURE

#### 1. PRECONDITIONING

If DTC Confirmation Procedure has been previously conducted, always perform the following procedure before conducting the next test.

1. Turn ignition switch OFF and wait at least 10 seconds.
2. Turn ignition switch ON.
3. Turn ignition switch OFF and wait at least 10 seconds.

#### Which DTC is detected?

P0102 >> GO TO 2.

P0103 >> GO TO 3.

#### 2. PERFORM DTC CONFIRMATION PROCEDURE FOR DTC P0102

1. Start engine and wait at least 5 seconds.
2. Check DTC.

#### Is DTC detected?

YES >> Proceed to [EC-206. "Diagnosis Procedure"](#).

NO >> INSPECTION END

#### 3. PERFORM DTC CONFIRMATION PROCEDURE FOR DTC P0103-1

1. Turn ignition switch ON and wait at least 5 seconds.
2. Check DTC.

#### Is DTC detected?

YES >> Proceed to [EC-206. "Diagnosis Procedure"](#).

NO >> GO TO 4.

#### 4. PERFORM DTC CONFIRMATION PROCEDURE FOR DTC P0103-2

1. Start engine and wait at least 5 seconds.
2. Check DTC.

# P0102, P0103 MAF SENSOR

[QR25DE]

< DTC/CIRCUIT DIAGNOSIS >

Is DTC detected?

- YES >> Proceed to [EC-206, "Diagnosis Procedure"](#).
- NO >> INSPECTION END

## Diagnosis Procedure

INFOID:000000011277953

### 1.INSPECTION START

Confirm the detected DTC.

Which DTC is detected?

- P0102 >> GO TO 2.
- P0103 >> GO TO 3.

### 2.CHECK INTAKE SYSTEM

Check the following for connection.

- Air duct
- Vacuum hoses
- Intake air passage between air duct to intake manifold

Is the inspection result normal?

- YES >> GO TO 3.
- NO >> Reconnect the parts. Refer to [EM-26, "Exploded View"](#).

### 3.CHECK MAF SENSOR POWER SUPPLY

1. Turn ignition switch OFF.
2. Disconnect mass air flow (MAF) sensor harness connector.
3. Turn ignition switch ON.
4. Check the voltage between MAF sensor harness connector and ground.

+		-	Voltage
MAF sensor			
Connector	Terminal		
F22	1	Ground	5 V

Is the inspection result normal?

- YES >> GO TO 5.
- NO >> GO TO 4.

### 4.CHECK SENSOR POWER SUPPLY 2 CIRCUIT

Perform [EC-487, "Diagnosis Procedure"](#).

Is the inspection result normal?

- YES >> Perform the trouble diagnosis for power supply circuit.
- NO >> Repair or replace error-detected parts.

### 5.CHECK MAF SENSOR GROUND CIRCUIT

1. Turn ignition switch OFF.
2. Disconnect ECM harness connector.
3. Check the continuity between MAF sensor harness connector and ECM harness connector.

+		-		Continuity
MAF sensor		ECM		
Connector	Terminal	Connector	Terminal	
F22	2	F51	34	Existed

Is the inspection result normal?

- YES >> GO TO 6.
- NO >> Repair or replace error-detected parts.

### 6.CHECK MAF SENSOR INPUT SIGNAL CIRCUIT

# P0102, P0103 MAF SENSOR

[QR25DE]

## < DTC/CIRCUIT DIAGNOSIS >

1. Check the continuity between MAF sensor harness connector and ECM harness connector.

+		-		Continuity
MAF sensor		ECM		
Connector	Terminal	Connector	Terminal	
F22	3	F51	35	Existed

2. Also check harness for short to ground and to power.

Is the inspection result normal?

YES >> GO TO 7.

NO >> Repair open circuit or short to ground or short to power in harness or connectors.

## 7.CHECK MAF SENSOR

Check the MAF sensor. Refer to [EC-203, "Component Inspection"](#).

Is the inspection result normal?

YES >> GO TO 8.

NO >> Replace mass air flow sensor. Refer to [EM-26, "Exploded View"](#).

## 8.CHECK INTERMITTENT INCIDENT

Refer to [GI-44, "Intermittent Incident"](#).

>> INSPECTION END

## Component Inspection

INFOID:0000000011277954

## 1.CHECK MASS AIR FLOW SENSOR-1

Ⓜ With CONSULT

1. Turn ignition switch OFF.
2. Reconnect all harness connectors disconnected.
3. Start engine and warm it up to normal operating temperature.
4. Connect CONSULT and select "DATA MONITOR" mode of "ENGINE".
5. Select "MASS AIR FLOW SENSOR (Hz)" and check indication.

Monitor item	Condition	Value
MASS AIR FLOW SENSOR (Hz)	Ignition switch ON (Engine stopped.)	Approx. 3500 Hz
	Idle (Engine is warmed-up to normal operating temperature.)	3500- 4100 Hz
	2,500 rpm (Engine is warmed-up to normal operating temperature.)	5000 - 5600 Hz
	Idle to about 4,000 rpm	3500 - 4100 Hz to Approx. 6300 Hz*

\*: Check for linear frequency rise in response to engine being increased to about 4,000 rpm.

Is the inspection result normal?

YES >> INSPECTION END

NO >> GO TO 2.

## 2.CHECK FOR THE CAUSE OF UNEVEN AIR FLOW THROUGH MASS AIR FLOW SENSOR

1. Turn ignition switch OFF.
2. Check for the cause of uneven air flow through mass air flow sensor. Refer to the following.
  - Crushed air ducts
  - Malfunctioning seal of air cleaner element
  - Uneven dirt of air cleaner element
  - Intake valve deposits
  - Improper specification of intake air system parts

Is the inspection result normal?

YES >> GO TO 4.

# P0102, P0103 MAF SENSOR

[QR25DE]

< DTC/CIRCUIT DIAGNOSIS >

NO >> GO TO 3.

## 3. CHECK MASS AIR FLOW SENSOR-2

④ With CONSULT

1. Repair or replace malfunctioning part.
2. Start engine and warm it up to normal operating temperature.
3. Connect CONSULT and select "DATA MONITOR" mode of "ENGINE".
4. Select "MASS AIR FLOW SENSOR (Hz)" and check indication.

Monitor item	Condition	Value
MASS AIR FLOWSENSOR (Hz)	Ignition switch ON (Engine stopped.)	Approx. 3500 Hz
	Idle (Engine is warmed-up to normal operating temperature.)	3500- 4100 Hz
	2,500 rpm (Engine is warmed-up to normal operating temperature.)	5000 - 5600 Hz
	Idle to about 4,000 rpm	3500 - 4100 Hz to Approx. 6300 Hz*

\*: Check for linear frequency rise in response to engine being increased to about 4,000 rpm.

Is the inspection result normal?

YES >> INSPECTION END

NO >> GO TO 4.

## 4. CHECK MASS AIR FLOW SENSOR-3

④ With CONSULT

1. Turn ignition switch OFF.
2. Disconnect mass air flow sensor harness connector and reconnect it again.
3. Start engine and warm it up to normal operating temperature.
4. Connect CONSULT and select "DATA MONITOR" mode of "ENGINE".
5. Select "MASS AIR FLOW SENSOR (Hz)" and check indication.

Monitor item	Condition	Value
MASS AIR FLOWSENSOR (Hz)	Ignition switch ON (Engine stopped.)	Approx. 3500 Hz
	Idle (Engine is warmed-up to normal operating temperature.)	3500- 4100 Hz
	2,500 rpm (Engine is warmed-up to normal operating temperature.)	5000 - 5600 Hz
	Idle to about 4,000 rpm	3500 - 4100 Hz to Approx. 6300 Hz*

\*: Check for linear frequency rise in response to engine being increased to about 4,000 rpm.

Is the inspection result normal?

YES >> INSPECTION END

NO >> Clean or replace mass air flow sensor. Refer to [EM-26. "Exploded View"](#).



# P0111 IAT SENSOR

< DTC/CIRCUIT DIAGNOSIS >

[QR25DE]

## P0111 IAT SENSOR

### DTC Description

INFOID:0000000011277955

### DTC DETECTION LOGIC

DTC No.	CONSULT screen terms (Trouble diagnosis content)	DTC detecting condition
P0111	IAT SENSOR 1 B1 (Intake air temperature sensor 1 circuit range/performance bank 1)	The comparison result of signals transmitted to ECM from each temperature sensor (IAT sensor, ECT sensor, FTT sensor, and EOT sensor) shows that the voltage signal of the IAT sensor is higher/lower than that of other temperature sensors when the engine is started with its cold state.

### POSSIBLE CAUSE

- Harness or connectors (High or low resistance in the IAT sensor circuit)
- IAT sensor

### FAIL-SAFE

Not applicable

### DTC CONFIRMATION PROCEDURE

#### 1.INSPECTION START

#### Is it necessary to erase permanent DTC?

YES >> GO TO 3.

NO >> GO TO 2.

#### 2.CHECK INTAKE AIR TEMPERATURE (IAT) SENSOR

1. Turn ignition switch OFF.
2. Disconnect mass air flow sensor harness connector and reconnect it again.
3. Turn ignition switch ON.
4. Select "DATA MONITOR" mode with CONSULT.
5. Check that "INT/A TEMP SEN" indicates as per following condition.

Monitor item	Condition	Value (Approx.)
INT/A TEMP SEN	Temperature [°C (°F)]	25 (77) 1.9 - 2.1 (V)

#### Is the inspection result normal?

YES >> GO TO 5.

NO >> Proceed to [EC-210, "Diagnosis Procedure"](#).

#### 3.PRECONDITIONING

If DTC CONFIRMATION PROCEDURE has been previously conducted, always perform the following procedure before conducting the next test.

1. Turn ignition switch OFF and wait at least 10 seconds.
2. Turn ignition switch ON.
3. Turn ignition switch OFF and wait at least 10 seconds.

#### TESTING CONDITION:

- Before performing the following procedure, do not add fuel.
- Before performing the following procedure, check that fuel level is between 1/4 and 4/4.
- Before performing the following procedure, confirm that battery voltage is 11 V or more at idle.

>> GO TO 4.

#### 4.PERFORM DTC CONFIRMATION PROCEDURE

1. Move the vehicle to a cool place.

#### NOTE:

Cool the vehicle in an environment of ambient air temperature between -10°C (14°F) and 35°C (95°F).

# P0111 IAT SENSOR

[QR25DE]

## < DTC/CIRCUIT DIAGNOSIS >

2. Turn ignition switch OFF and leave the vehicle for 12 hours.

**CAUTION:**

**Never turn ignition switch ON during this procedure.**

**NOTE:**

The vehicle must be cooled with the hood open.

3. Start engine and let it idle for 5 minutes or more.

**CAUTION:**

**Never turn ignition switch OFF during idling.**

4. Check 1st trip DTC.

### Is 1st trip DTC detected?

YES >> Proceed to [EC-210, "Diagnosis Procedure"](#).

NO >> INSPECTION END

## 5.CHECK INTERMITTENT INCIDENT

Refer to [GI-44, "Intermittent Incident"](#).

>> INSPECTION END

## Diagnosis Procedure

INFOID:0000000011277956

### 1.CHECK INTAKE AIR TEMPERATURE (IAT) SENSOR

Check intake air temperature sensor. Refer to [EC-210, "Component Inspection"](#).

#### Is the inspection result normal?

YES >> GO TO 2.

NO >> Replace mass air flow sensor (with intake air temperature sensor). Refer to [EM-26, "Exploded View"](#).

### 2.CHECK INTERMITTENT INCIDENT

Refer to [GI-44, "Intermittent Incident"](#).

>> INSPECTION END

## Component Inspection

INFOID:0000000011277957

### 1.CHECK INTAKE AIR TEMPERATURE SENSOR

1. Turn ignition switch OFF.
2. Disconnect mass air flow sensor harness connector and reconnect it again.
3. Turn ignition switch ON.
4. Select "DATA MONITOR" mode with CONSULT.
5. Check that "INT/A TEMP SEN" indicates as per following condition.

Monitor item	Condition	Value (Approx.)
INT/A TEMP SEN	Temperature [°C (°F)]	25 (77) 1.9 - 2.1 (V)

#### Is the inspection result normal?

YES >> INSPECTION END

NO >> Replace mass air flow sensor (with intake air temperature sensor). Refer to [EM-26, "Exploded View"](#).

# P0112, P0113 IAT SENSOR

< DTC/CIRCUIT DIAGNOSIS >

[QR25DE]

## P0112, P0113 IAT SENSOR

### DTC Description

INFOID:000000011277958

### DTC DETECTION LOGIC

DTC No.	CONSULT screen terms (Trouble diagnosis content)	DTC detecting condition
P0112	IAT SEN/CIRCUIT- B1 (Intake air temperature sensor 1 circuit low bank 1)	An excessively low voltage from the intake air temperature sensor is sent to ECM.
P0113	IAT SEN/CIRCUIT- B1 (Intake air temperature sensor 1 circuit high bank 1)	An excessively high voltage from the intake air temperature sensor is sent to ECM.

### POSSIBLE CAUSE

- Harness or connectors (Intake air temperature sensor circuit is open or shorted.)
- Intake air temperature sensor
- Sensor power supply 2 circuit

### FAIL-SAFE

Not applicable

### DTC CONFIRMATION PROCEDURE

#### 1.PRECONDITIONING

If DTC Confirmation Procedure has been previously conducted, always perform the following procedure before conducting the next test.

1. Turn ignition switch OFF and wait at least 10 seconds.
2. Turn ignition switch ON.
3. Turn ignition switch OFF and wait at least 10 seconds.

>> GO TO 2.

#### 2.PERFORM DTC CONFIRMATION PROCEDURE

1. Turn ignition switch ON and wait at least 5 seconds.
2. Check 1st trip DTC.

#### Is 1st trip DTC detected?

- YES >> Proceed to [EC-211, "Diagnosis Procedure"](#).  
 NO >> INSPECTION END

### Diagnosis Procedure

INFOID:000000011277959

#### 1.CHECK INTAKE AIR TEMPERATURE SENSOR POWER SUPPLY

1. Turn ignition switch OFF.
2. Disconnect mass air flow sensor (with intake air temperature sensor) harness connector.
3. Turn ignition switch ON.
4. Check the voltage between mass air flow sensor harness connector and ground.

+		-	Voltage (Approx.)
MAF sensor			
Connector	Terminal		
F31	4	Ground	5 V

#### Is the inspection result normal?

- YES >> GO TO 3.  
 NO >> GO TO 2.

# P0112, P0113 IAT SENSOR

[QR25DE]

< DTC/CIRCUIT DIAGNOSIS >

## 2. CHECK INTAKE AIR TEMPERATURE SENSOR POWER SUPPLY CIRCUIT

1. Turn ignition switch OFF.
2. Disconnect ECM harness connector.
3. Check the continuity between mass air flow sensor harness connector and ECM harness connector.

+		-		Continuity
MAF sensor		ECM		
Connector	Terminal	Connector	Terminal	
F22	4	F51	33	Existed

4. Also check harness for short to ground.

Is the inspection result normal?

YES >> Perform the trouble diagnosis for power supply circuit.

NO >> Repair or replace error-detected parts.

## 3. CHECK INTAKE AIR TEMPERATURE SENSOR GROUND CIRCUIT

1. Turn ignition switch OFF.
2. Disconnect ECM harness connector.
3. Check the continuity between mass air flow sensor harness connector and ECM harness connector.

+		-		Continuity
MAF sensor		ECM		
Connector	Terminal	Connector	Terminal	
F22	2	F51	34	Existed

4. Also check harness for short to power.

Is the inspection result normal?

YES >> GO TO 4.

NO >> Repair or replace error-detected parts.

## 4. CHECK INTAKE AIR TEMPERATURE SENSOR

Check the intake air temperature sensor. Refer to [EC-210, "Component Inspection"](#).

Is the inspection result normal?

YES >> GO TO 5.

NO >> Replace mass air flow sensor (with intake air temperature sensor). Refer to [EM-26, "Exploded View"](#).

## 5. CHECK INTERMITTENT INCIDENT

Refer to [GI-44, "Intermittent Incident"](#).

>> INSPECTION END

## Component Inspection

INFOID:000000011277960

### 1. CHECK INTAKE AIR TEMPERATURE SENSOR

1. Turn ignition switch OFF.
2. Disconnect mass air flow sensor harness connector and reconnect it again.
3. Turn ignition switch ON.
4. Select "DATA MONITOR" mode with CONSULT.
5. Check that "INT/A TEMP SEN" indicates as per following condition.

Monitor item	Condition	Value (Approx.)
INT/A TEMP SEN	Temperature [°C (°F)]	25 (77) 1.9 - 2.1 (V)

Is the inspection result normal?

# P0112, P0113 IAT SENSOR

[QR25DE]

< DTC/CIRCUIT DIAGNOSIS >

YES >> INSPECTION END

NO >> Replace mass air flow sensor (with intake air temperature sensor). Refer to [EM-26, "Exploded View"](#).

A

EC

C

D

E

F

G

H

I

J

K

L

M

N

O

P

P0116 ECT SENSOR

DTC Description

INFOID:000000011277961

DTC DETECTION LOGIC

DTC No.	CONSULT screen terms (Trouble diagnosis content)	DTC detecting condition
P0116	ECT SENSOR (Engine coolant temperature sensor 1 circuit range/performance)	The comparison result of signals transmitted to ECM from each temperature sensor (IAT sensor, ECT sensor, FTT sensor, and EOT sensor) shows that the voltage signal of the ECT sensor is higher/lower than that of other temperature sensors when the engine is started with its cold state.

POSSIBLE CAUSE

- Harness or connectors (High or low resistance in the ECT sensor circuit)
- ECT sensor

FAIL-SAFE

Not applicable

DTC CONFIRMATION PROCEDURE

1.INSPECTION START

Is it necessary to erase permanent DTC?

YES >> GO TO 3.

NO >> GO TO 2.

2.CHECK ENGINE COOLANT TEMPERATURE (ECT) SENSOR

1. Turn ignition switch OFF.
2. Disconnect ECT sensor harness connector.
3. Remove ECT sensor. Refer to [CO-23, "Exploded View"](#).
4. Check resistance between ECT sensor terminals by heating with hot water as shown in the figure.

ECT sensor		Condition	Resistance (kΩ)	
+	-			
Terminal				
1	2	Temperature [°C (°F)]	20 (68)	2.37 – 2.63
			50 (122)	0.68 – 1.00
			90 (194)	0.236 – 0.260

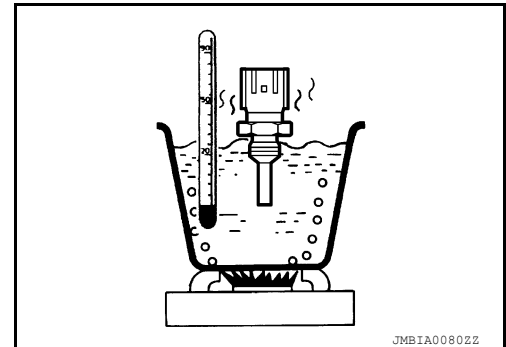

Is the inspection result normal?

YES >> GO TO 5.

NO >> Proceed to [EC-215, "Diagnosis Procedure"](#).

3.PRECONDITIONING

If DTC CONFIRMATION PROCEDURE has been previously conducted, always perform the following procedure before conducting the next test.

1. Turn ignition switch OFF and wait at least 10 seconds.
2. Turn ignition switch ON.
3. Turn ignition switch OFF and wait at least 10 seconds.

**TESTING CONDITION:**

- Before performing the following procedure, do not add fuel.
- Before performing the following procedure, check that fuel level is between 1/4 and 4/4.
- Before performing the following procedure, confirm that battery voltage is 11 V or more at idle.

>> GO TO 4.

# P0116 ECT SENSOR

< DTC/CIRCUIT DIAGNOSIS >

[QR25DE]

## 4. PERFORM DTC CONFIRMATION PROCEDURE

1. Move the vehicle to a cool place.

**NOTE:**

Cool the vehicle in an environment of ambient air temperature between -10°C (14°F) and 35°C (95°F).

2. Turn ignition switch OFF and leave the vehicle for 12 hours.

**CAUTION:**

**Never turn ignition switch ON during this procedure.**

**NOTE:**

The vehicle must be cooled with the hood open.

3. Start engine and let it idle for 5 minutes or more.

**CAUTION:**

**Never turn ignition switch OFF during idling.**

4. Check 1st trip DTC.

Is 1st trip DTC detected?

YES >> Proceed to [EC-215, "Diagnosis Procedure"](#).

NO >> INSPECTION END

## 5. CHECK INTERMITTENT INCIDENT

Refer to [GI-44, "Intermittent Incident"](#).

>> INSPECTION END

## Diagnosis Procedure

INFOID:000000011277962

### 1. CHECK ENGINE COOLANT TEMPERATURE (ECT) SENSOR

Check ECT sensor. Refer to [EC-215, "Component Inspection"](#).

Is the inspection result normal?

YES >> GO TO 2.

NO >> Replace ECT sensor. Refer to [CO-23, "Exploded View"](#).

### 2. CHECK INTERMITTENT INCIDENT

Refer to [GI-44, "Intermittent Incident"](#).

>> INSPECTION END

## Component Inspection

INFOID:000000011277963

### 1. CHECK ENGINE COOLANT TEMPERATURE (ECT) SENSOR

1. Turn ignition switch OFF.
2. Disconnect ECT sensor harness connector.
3. Remove ECT sensor.
4. Check resistance between ECT sensor terminals by heating with hot water as shown in the figure.

ECT sensor		Condition	Resistance (kΩ)
+	-		
Terminal			
1	2	20 (68)	2.37 - 2.63
		50 (122)	0.68 - 1.00
		90 (194)	0.236 - 0.260

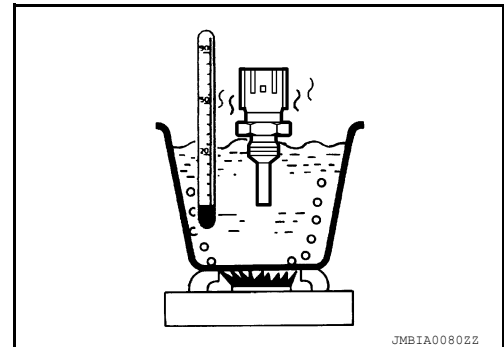

Is the inspection result normal?

YES >> INSPECTION END

NO >> Replace engine coolant temperature sensor. Refer to [CO-23, "Exploded View"](#).

# P0117, P0118 ECT SENSOR

[QR25DE]

< DTC/CIRCUIT DIAGNOSIS >

## P0117, P0118 ECT SENSOR

### DTC Description

INFOID:000000011277964

### DTC DETECTION LOGIC

DTC No.	CONSULT screen terms (Trouble diagnosis content)	DTC detecting condition
P0117	ECT SEN/CIRC (Engine coolant temperature sensor 1 circuit low)	An excessively low voltage from the engine coolant temperature sensor is sent to ECM.
P0118	ECT SEN/CIRC (Engine coolant temperature sensor 1 circuit high)	An excessively high voltage from the engine coolant temperature sensor is sent to ECM.

### POSSIBLE CAUSE

- Harness or connectors (Engine coolant temperature sensor circuit is open or shorted.)
- Engine coolant temperature sensor

### FAIL-SAFE

Not applicable

### DTC CONFIRMATION PROCEDURE

#### 1. PRECONDITIONING

If DTC Confirmation Procedure has been previously conducted, always perform the following procedure before conducting the next test.

1. Turn ignition switch OFF and wait at least 10 seconds.
2. Turn ignition switch ON.
3. Turn ignition switch OFF and wait at least 10 seconds.

>> GO TO 2.

#### 2. PERFORM DTC CONFIRMATION PROCEDURE

1. Turn ignition switch ON and wait at least 5 seconds.
2. Check DTC.

#### Is DTC detected?

- YES >> Proceed to [EC-216, "Diagnosis Procedure"](#).  
NO >> INSPECTION END

### Diagnosis Procedure

INFOID:000000011277965

#### 1. CHECK ENGINE COOLANT TEMPERATURE SENSOR POWER SUPPLY

1. Turn ignition switch OFF.
2. Disconnect engine coolant temperature (ECT) sensor harness connector.
3. Turn ignition switch ON.
4. Check the voltage between ECT sensor harness connector and ground.

+		-	Voltage (Approx. )
ECT sensor			
Connector	Terminal		
F61	1	Ground	5 V

#### Is the inspection result normal?

- YES >> GO TO 3.  
NO >> GO TO 2.

#### 2. CHECK ENGINE COOLANT TEMPERATURE SENSOR POWER SUPPLY CIRCUIT



# P0117, P0118 ECT SENSOR

[QR25DE]

## < DTC/CIRCUIT DIAGNOSIS >

1. Turn ignition switch OFF.
2. Disconnect ECM harness connector.
3. Check the continuity between ECT sensor harness connector and ECM harness connector.

+		-		Continuity
ECT sensor		ECM		
Connector	Terminal	Connector	Terminal	
F61	1	F51	28	Existed

4. Also check harness for short to ground.

### Is the inspection result normal?

- YES >> Perform the trouble diagnosis for power supply circuit.  
NO >> Repair or replace error-detected parts.

## 3.CHECK ENGINE COOLANT TEMPERATURE SENSOR GROUND CIRCUIT

1. Turn ignition switch OFF.
2. Disconnect ECM harness connector.
3. Check the continuity between ECT sensor harness connector and ECM harness connector.

+		-		Continuity
ECT sensor		ECM		
Connector	Terminal	Connector	Terminal	
F61	2	F51	27	Existed

4. Also check harness for short to ground to power.

### Is the inspection result normal?

- YES >> GO TO 4.  
NO >> Repair or replace error-detected parts.

## 4.CHECK ENGINE COOLANT TEMPERATURE SENSOR

Check the engine coolant temperature sensor. Refer to [EC-215, "Component Inspection"](#).

### Is the inspection result normal?

- YES >> GO TO 5.  
NO >> Replace engine coolant temperature sensor. Refer to [CO-23, "Exploded View"](#).

## 5.CHECK INTERMITTENT INCIDENT

Refer to [GI-44, "Intermittent Incident"](#).

>> INSPECTION END

## Component Inspection

INFOID:0000000011277966

## 1.CHECK ENGINE COOLANT TEMPERATURE (ECT) SENSOR

1. Turn ignition switch OFF.
2. Disconnect ECT sensor harness connector.
3. Remove ECT sensor.

# P0117, P0118 ECT SENSOR

[QR25DE]

## < DTC/CIRCUIT DIAGNOSIS >

4. Check resistance between ECT sensor terminals by heating with hot water as shown in the figure.

ECT sensor		Condition	Resistance (kΩ)
+	-		
Terminal			
1	2	20 (68)	2.37 - 2.63
		50 (122)	0.68 - 1.00
		90 (194)	0.236 - 0.260

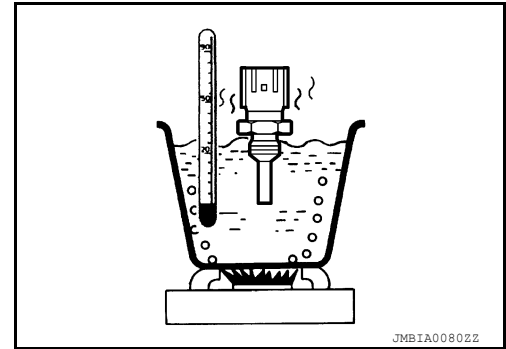

Is the inspection result normal?

YES >> INSPECTION END

NO >> Replace engine coolant temperature sensor. Refer to [CO-23, "Exploded View"](#).

# P0122, P0123 TP SENSOR

< DTC/CIRCUIT DIAGNOSIS >

[QR25DE]

## P0122, P0123 TP SENSOR

### DTC Description

INFOID:000000011277967

### DTC DETECTION LOGIC

DTC No.	CONSULT screen terms (Trouble diagnosis content)	DTC detecting condition
P0122	TP SEN 2/CIRC-B1 (Throttle/pedal position sensor/switch "A" circuit low)	An excessively low voltage from the TP sensor 2 is sent to ECM.
P0123	TP SEN 2/CIRC-B1 (Throttle/pedal position sensor/switch "A" circuit high)	An excessively high voltage from the TP sensor 2 is sent to ECM.

### POSSIBLE CAUSE

- Harness or connectors (TP sensor 2 circuit is open or shorted.)
- Electric throttle control actuator (TP sensor 2)

### FAIL-SAFE

- The ECM controls the electric throttle control actuator in regulating the throttle opening in order for the idle position to be within +10 degrees.
- The ECM regulates the opening speed of the throttle valve to be slower than the normal condition. So, the acceleration will be poor.

### DTC CONFIRMATION PROCEDURE

#### 1.CHECK DTC PRIORITY

If DTC P0122 or P0123 is displayed with DTC P0643, first perform the trouble diagnosis for DTC P0643.

#### Is applicable DTC detected?

- YES >> Perform diagnosis of applicable. Refer to [EC-382, "DTC Description"](#).  
NO >> GO TO 2.

#### 2.PRECONDITIONING

If DTC Confirmation Procedure has been previously conducted, always perform the following procedure before conducting the next test.

1. Turn ignition switch OFF and wait at least 10 seconds.
2. Turn ignition switch ON.
3. Turn ignition switch OFF and wait at least 10 seconds.

#### **TESTING CONDITION:**

**Before performing the following procedure, confirm that battery voltage is more than 8 V at idle.**

>> GO TO 3.

#### 3.PERFORM DTC CONFIRMATION PROCEDURE

1. Start engine and let it idle for 1 second.
2. Check DTC.

#### Is DTC detected?

- YES >> Proceed to [EC-219, "Diagnosis Procedure"](#).  
NO >> INSPECTION END

### Diagnosis Procedure

INFOID:000000011277968

#### 1.CHECK DTC PRIORITY

If DTC P0122 or P0123 is displayed with DTC P0643, first perform the trouble diagnosis for DTC P0643.

#### Is applicable DTC detected?

- YES >> Perform diagnosis of applicable. Refer to [EC-382, "DTC Description"](#).  
NO >> GO TO 2.

# P0122, P0123 TP SENSOR

[QR25DE]

< DTC/CIRCUIT DIAGNOSIS >

## 2. CHECK THROTTLE POSITION SENSOR 2 POWER SUPPLY

1. Turn ignition switch OFF.
2. Disconnect electric throttle control actuator harness connector.
3. Turn ignition switch ON.
4. Check the voltage between electric throttle control actuator harness connector and ground.

+		-	Voltage (Approx.)
Electric throttle control actuator			
Connector	Terminal		
F50	2	Ground	5 V

Is the inspection result normal?

YES >> GO TO 4.

NO >> GO TO 3.

## 3. CHECK THROTTLE POSITION SENSOR 2 POWER SUPPLY CIRCUIT

1. Turn ignition switch OFF.
2. Disconnect ECM harness connector.
3. Check the continuity between electric throttle control actuator harness connector and ECM harness connector.

+		-		Continuity
Electric throttle control actuator		ECM		
Connector	Terminal	Connector	Terminal	
F50	2	F52	80	Existed

4. Also check harness for short to power.

Is the inspection result normal?

YES >> Perform the trouble diagnosis for power supply circuit.

NO >> Repair or replace error-detected parts.

## 4. CHECK THROTTLE POSITION SENSOR 2 GROUND CIRCUIT

1. Turn ignition switch OFF.
2. Disconnect ECM harness connector.
3. Check the continuity between electric throttle control actuator harness connector and ECM harness connector.

+		-		Continuity
Electric throttle control actuator		ECM		
Connector	Terminal	Connector	Terminal	
F50	4	F52	78	Existed

Is the inspection result normal?

YES >> GO TO 5.

NO >> Repair or replace error-detected parts.

## 5. CHECK THROTTLE POSITION SENSOR 2 INPUT SIGNAL CIRCUIT

1. Check the continuity between electric throttle control actuator harness connector and ECM harness connector.

# P0122, P0123 TP SENSOR

< DTC/CIRCUIT DIAGNOSIS >

[QR25DE]

+		-		Continuity
Electric throttle control actuator		ECM		
Connector	Terminal	Connector	Terminal	
F50	3	F52	77	Existed

2. Also check harness for short to ground and to power.

Is the inspection result normal?

YES >> GO TO 6.

NO >> Repair or replace error-detected parts.

## 6. CHECK THROTTLE POSITION SENSOR

Check the throttle position sensor. Refer to [EC-221, "Component Inspection"](#).

Is the inspection result normal?

YES >> GO TO 7.

NO >> Replace electric throttle control actuator. Refer to [EM-29, "Removal and Installation"](#).

## 7. CHECK INTERMITTENT INCIDENT

Refer to [GI-44, "Intermittent Incident"](#).

>> INSPECTION END

## Component Inspection

INFOID:000000011277969

## 1. CHECK THROTTLE POSITION SENSOR

1. Turn ignition switch OFF.
2. Reconnect all harness connectors disconnected.
3. Perform "Throttle Valve Closed Position Learning". Refer to [EC-143, "Work Procedure"](#).
4. Turn ignition switch ON.
5. Set selector lever to D position.
6. Check the voltage between ECM harness connector terminals as per the following conditions.

ECM				Condition	Voltage	
Connector	+	-	Terminal			
Sensor 1	F52	79	78	Accelerator pedal	Fully released	More than 0.36V
					Fully depressed	Less than 4.75V
Sensor 2	77				Fully released	Less than 4.75V
					Fully depressed	More than 0.36V

Is the inspection result normal?

YES >> INSPECTION END

NO >> Replace electric throttle control actuator. Refer to [EM-29, "Removal and Installation"](#).

## P0125 ECT SENSOR

### DTC Description

INFOID:000000011277970

### DTC DETECTION LOGIC

DTC No.	CONSULT screen terms (Trouble diagnosis content)	DTC detecting condition
P0125	ECT SENSOR (Insufficient coolant temperature for closed loop fuel control)	<ul style="list-style-type: none"> <li>Voltage sent to ECM from the sensor is not practical, even when some time has passed after starting the engine.</li> <li>Engine coolant temperature is insufficient for closed loop fuel control.</li> </ul>

### POSSIBLE CAUSE

- Harness or connectors (High resistance in the circuit)
- Engine coolant temperature sensor
- Thermostat

### FAIL-SAFE

Not applicable

### DTC CONFIRMATION PROCEDURE

#### 1. CHECK DTC PRIORITY

If DTC P0125 is displayed with DTC P0116 or P0117, first perform the trouble diagnosis for DTC P0116 or P0117.

#### Is applicable DTC detected?

- YES >> Perform diagnosis of applicable. Refer to [EC-96, "DTC Index"](#).  
 NO >> GO TO 2.

#### 2. PRECONDITIONING

If DTC Confirmation Procedure has been previously conducted, always perform the following procedure before conducting the next test.

1. Turn ignition switch OFF and wait at least 10 seconds.
2. Turn ignition switch ON.
3. Turn ignition switch OFF and wait at least 10 seconds.

>> GO TO 3.

#### 3. CHECK ENGINE COOLANT TEMPERATURE SENSOR FUNCTION

##### With CONSULT

1. Turn ignition switch ON.
2. Select "DATA MONITOR" mode of "ENGINE" using CONSULT.
3. Check that "COOLAN TEMP/S" is above 10°C (50°F).

##### With GST

Follow the procedure "With CONSULT" above.

#### Is it above 5°C (41°F)?

- YES >> INSPECTION END  
 NO >> GO TO 4.

#### 4. PERFORM DTC CONFIRMATION PROCEDURE

##### With CONSULT

1. Start engine and run it for 65 minutes at idle speed.
2. Check 1st tip DTC.

**If "COOLAN TEMP/S" indication increases to more than 10°C (50°F) within 65 minutes, stop engine because the test result will be OK.**

#### **CAUTION:**

**Be careful not to overheat engine.**

##### With GST

Follow the procedure "With CONSULT" above.

# P0125 ECT SENSOR

[QR25DE]

< DTC/CIRCUIT DIAGNOSIS >

Is 1st trip DTC detected?

- YES >> Proceed to [EC-223, "Diagnosis Procedure"](#).
- NO >> INSPECTION END

## Diagnosis Procedure

INFOID:0000000011277971

### 1. CHECK DTC PRIORITY

If DTC P0125 is displayed with DTC P0116 or P0117, first perform the trouble diagnosis for DTC P0116 or P0117.

Is applicable DTC detected?

- YES >> Perform diagnosis of applicable. Refer to [EC-96, "DTC Index"](#).
- NO >> GO TO 2.

### 2. CHECK ENGINE COOLANT TEMPERATURE SENSOR

Check the engine coolant temperature sensor. Refer to [EC-215, "Component Inspection"](#).

Is the inspection result normal?

- YES >> GO TO 3.
- NO >> Replace engine coolant temperature sensor. Refer to [CO-23, "Exploded View"](#).

### 3. CHECK THERMOSTAT OPERATION

When the engine is cold [lower than 70°C (158°F)] condition, grasp lower radiator hose and confirm the engine coolant does not flow.

Is the inspection result normal?

- YES >> GO TO 4.
- NO >> Repair or replace thermostat. Refer to [CO-21, "Removal and Installation"](#).

### 4. CHECK INTERMITTENT INCIDENT

Refer to [GI-44, "Intermittent Incident"](#).

>> INSPECTION END

## Component Inspection

INFOID:0000000011277972

### 1. CHECK ENGINE COOLANT TEMPERATURE (ECT) SENSOR

1. Turn ignition switch OFF.
2. Disconnect ECT sensor harness connector.
3. Remove ECT sensor.
4. Check resistance between ECT sensor terminals by heating with hot water as shown in the figure.

ECT sensor		Condition	Resistance (kΩ)
+	-		
Terminal			
1	2	Temperature [°C (°F)]	20 (68)
			50 (122)
			90 (194)
			2.37 - 2.63
			0.68 - 1.00
			0.236 - 0.260

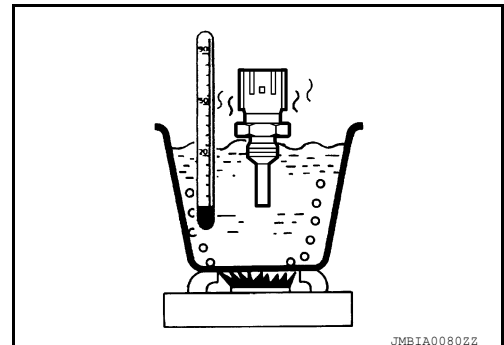

Is the inspection result normal?

- YES >> INSPECTION END
- NO >> Replace engine coolant temperature sensor. Refer to [CO-23, "Exploded View"](#).

# P0127 IAT SENSOR

< DTC/CIRCUIT DIAGNOSIS >

[QR25DE]

## P0127 IAT SENSOR

### DTC Description

INFOID:000000011277973

### DTC DETECTION LOGIC

DTC No.	CONSULT screen terms (Trouble diagnosis content)	DTC detecting condition
P0127	IAT SENSOR-B1 (Intake air temperature too high)	Rationally incorrect voltage from the sensor is sent to ECM, compared with the voltage signal from engine coolant temperature sensor.

### POSSIBLE CAUSE

- Harness or connectors (Intake air temperature sensor circuit is open or shorted.)
- Intake air temperature sensor

### FAIL-SAFE

Not applicable

### DTC CONFIRMATION PROCEDURE

#### 1. PRECONDITIONING

If DTC Confirmation Procedure has been previously conducted, always perform the following procedure before conducting the next test.

1. Turn ignition switch OFF and wait at least 10 seconds.
2. Turn ignition switch ON.
3. Turn ignition switch OFF and wait at least 10 seconds.

#### TESTING CONDITION:

**This test may be conducted with the drive wheels lifted in the shop or by driving the vehicle. If a road test is expected to be easier, it is unnecessary to lift the vehicle.**

>> GO TO 2.

#### 2. PERFORM DTC CONFIRMATION PROCEDURE

##### With CONSULT

1. Wait until engine coolant temperature is less than 96°C (205°F)
  - Turn ignition switch ON.
  - Select "DATA MONITOR" mode of "ENGINE" using CONSULT.
  - Check the engine coolant temperature.
  - If the engine coolant temperature is not less than 96°C (205°F), turn ignition switch OFF and cool down engine.

##### NOTE:

Perform the following steps before engine coolant temperature is above 96°C (205°F).

2. Turn ignition switch ON.
3. Select "DATA MONITOR" mode of "ENGINE" using CONSULT
4. Start engine.
5. Hold vehicle speed at more than 70 km/h (43 MPH) for 100 consecutive seconds.

##### CAUTION:

**Always drive vehicle at a safe speed.**

6. Check 1st trip DTC.

##### With GST

Follow the procedure "With CONSULT" above.

##### Is 1st trip DTC detected?

- YES >> Proceed to [EC-224, "Diagnosis Procedure"](#).  
NO >> INSPECTION END

### Diagnosis Procedure

INFOID:000000011277974

#### 1. CHECK INTAKE AIR TEMPERATURE SENSOR

Check the intake air temperature sensor. Refer to [EC-225, "Component Inspection"](#).



# P0127 IAT SENSOR

[QR25DE]

< DTC/CIRCUIT DIAGNOSIS >

Is the inspection result normal?

YES >> GO TO 2.

NO >> Replace mass air flow sensor (with intake air temperature sensor). Refer to [EM-26. "Exploded View"](#).

## 2. CHECK INTERMITTENT INCIDENT

Refer to [GI-44. "Intermittent Incident"](#).

>> INSPECTION END

## Component Inspection

INFOID:0000000011277975

### 1. CHECK INTAKE AIR TEMPERATURE SENSOR

1. Turn ignition switch OFF.
2. Disconnect mass air flow sensor harness connector and reconnect it again.
3. Turn ignition switch ON.
4. Select "DATA MONITOR" mode with CONSULT.
5. Check that "INT/A TEMP SEN" indicates as per following condition.

Monitor item	Condition	Value (Approx.)
INT/A TEMP SEN	Temperature [°C (°F)]	25 (77) 1.9 - 2.1 (V)

Is the inspection result normal?

YES >> INSPECTION END

NO >> Replace mass air flow sensor (with intake air temperature sensor). Refer to [EM-26. "Exploded View"](#).

# P0128 THERMOSTAT FUNCTION

< DTC/CIRCUIT DIAGNOSIS >

[QR25DE]

## P0128 THERMOSTAT FUNCTION

### DTC Description

INFOID:000000011277976

### DTC DETECTION LOGIC

Engine coolant temperature has not risen enough to open the thermostat even though the engine has run long enough.

This is due to a leak in the seal or the thermostat being stuck open.

DTC No.	CONSULT screen terms (Trouble diagnosis content)	DTC detecting condition
P0128	THERMSTAT FNCTN [Coolant thermostat (coolant temperature below thermostat regulating temperature)]	The engine coolant temperature does not reach to specified temperature even though the engine has run long enough.

### POSSIBLE CAUSE

- Thermostat
- Leakage from sealing portion of thermostat
- Engine coolant temperature sensor

### FAIL-SAFE

Not applicable

### DTC CONFIRMATION PROCEDURE

#### NOTE:

Never refuel before and during the following procedure.

#### 1. CHECK DTC PRIORITY

If DTC P0128 is displayed with DTC P0300, P0301, P0302, P0303 or P0304, first perform the trouble diagnosis for DTC P0300, P0301, P0302, P0303 or P0304.

#### Is applicable DTC detected?

- YES >> Perform diagnosis of applicable. Refer to [EC-96. "DTC Index"](#).  
NO >> GO TO 2.

#### 2. PRECONDITIONING-1

If DTC Confirmation Procedure has been previously conducted, always perform the following procedure before conducting the next test.

1. Turn ignition switch OFF and wait at least 10 seconds.
2. Turn ignition switch ON.
3. Turn ignition switch OFF and wait at least 10 seconds.

>> GO TO 3.

#### 3. PRECONDITIONING-2

##### With CONSULT

1. Turn ignition switch ON.
2. Check the following conditions:

Ambient temperature	-10°C (14°F) or more
A/C switch	OFF
Blower fan switch	OFF

3. Select "DATA MONITOR" mode of "ENGINE" using CONSULT.
4. Check the following conditions:

COOLAN TEMP/S	-10°C – 58°C (14 – 136°F)
---------------	---------------------------

#### Is the condition satisfied?

- YES >> GO TO 4.

# P0128 THERMOSTAT FUNCTION

[QR25DE]

< DTC/CIRCUIT DIAGNOSIS >

- NO >> 1. Satisfy the condition.  
2. GO TO 4.

## 4.PERFORM DTC CONFIRMATION PROCEDURE-1

Ⓜ With CONSULT

1. Start engine.
2. Drive the vehicle until the following condition is satisfied.

**CAUTION:**

**Always drive vehicle at safe speed.**

- **STEP 1**

Drive the vehicle under the conditions instructed below until the difference between "COOLAN TEMP/S" and "FUEL T/TMP SE" becomes at least 26°C (47°F).

COOLAN TEMP/S	66°C (151°F) or less
FUEL T/TMP SE	Less than the value calculated by subtracting 26°C (47°F) from "COOLAN TEMP/S".*

\*: Example

COOLAN TEMP/S	FUEL T/TMP SE
70°C (158°F)	44°C (111°F) or less
65°C (149°F)	39°C (102°F) or less
60°C (140°F)	34°C (93°F) or less

- **STEP 2**

Drive the vehicle at 50 km/h (32 MPH) or more with the difference between "COOLAN TEMP/S" and "FUEL T/TMP SE" maintained at 26°C (47°F) or more.

**NOTE:**

Keep the accelerator pedal as steady as possible during cruising.

- **STEP 3**

Drive the vehicle at 50 km/h (32 MPH) or more until "COOLAN TEMP/S" increases by 6°C (11°F).

**NOTE:**

Keep the accelerator pedal as steady as possible during cruising.

Is the condition satisfied?

- YES >> GO TO 5.  
NO >> GO TO 2.

## 5.PERFORM DTC CONFIRMATION PROCEDURE-2

Ⓜ With CONSULT

1. Drive the vehicle until the following condition is satisfied.

COOLAN TEMP/S	67°C (153°F) or more
---------------	----------------------

**CAUTION:**

**Always drive vehicle at safe speed.**

2. Check 1st trip DTC.

Is 1st trip DTC detected?

- YES >> Proceed to [EC-227. "Diagnosis Procedure"](#).  
NO >> INSPECTION END

## Diagnosis Procedure

INFOID:0000000011277977

### 1.CHECK DTC PRIORITY

If DTC P0128 is displayed with DTC P0300, P0301, P0302, P0303 or P0304, first perform the trouble diagnosis for DTC P0300, P0301, P0302, P0303 or P0304.

Is applicable DTC detected?

- YES >> Perform diagnosis of applicable. Refer to [EC-96. "DTC Index"](#).  
NO >> GO TO 2.

# P0128 THERMOSTAT FUNCTION

< DTC/CIRCUIT DIAGNOSIS >

[QR25DE]

## 2. CHECK ENGINE COOLANT TEMPERATURE SENSOR

Check the engine coolant temperature sensor. Refer to [EC-228. "Component Inspection"](#).

Is the inspection result normal?

YES >> GO TO 3.

NO >> Replace engine coolant temperature sensor. Refer to [CO-23. "Exploded View"](#).

## 3. CHECK THERMOSTAT

Check the thermostat. Refer to [CO-21. "Removal and Installation"](#).

Is the inspection result normal?

YES >> INSPECTION END

NO >> Replace thermostat.

## Component Inspection

INFOID:000000011277978

## 1. CHECK ENGINE COOLANT TEMPERATURE SENSOR

1. Turn ignition switch OFF.
2. Disconnect engine coolant temperature sensor harness connector.
3. Remove engine coolant temperature sensor.
4. Check resistance between engine coolant temperature sensor terminals by heating with hot water as shown in the figure.

Engine coolant temperature sensor		Condition	Resistance (k $\Omega$ )	
+	-			
Terminal				
1	2	Temperature [ $^{\circ}$ C ( $^{\circ}$ F)]	20 (68)	2.37 - 2.63
			50 (122)	0.68 - 1.00
			90 (194)	0.236 - 0.260

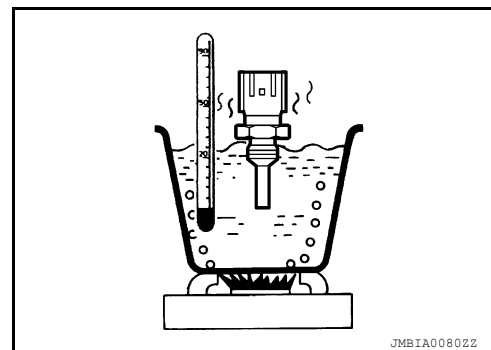

Is the inspection result normal?

YES >> INSPECTION END

NO >> Replace engine coolant temperature sensor. Refer to [CO-23. "Exploded View"](#).

P0130 A/F SENSOR 1

DTC Description

INFOID:000000011277979

DTC DETECTION LOGIC

To judge the malfunction, the diagnosis checks that the A/F signal computed by ECM from the A/F sensor 1 signal fluctuates according to fuel feedback control.

DTC No.	CONSULT screen terms (Trouble diagnosis content)	DTC detecting condition	
P0130	A/F SENSOR1 (B1) (O2 sensor circuit bank 1 sensor 1)	A	The A/F signal computed by ECM from the A/F sensor 1 signal is constantly in the range other than approx. 2.2 V.
		B	The A/F signal computed by ECM from the A/F sensor 1 signal is constantly approx. 2.2 V.

POSSIBLE CAUSE

- Harness or connectors (A/F sensor 1 circuit is open or shorted.)
- A/F sensor 1

FAIL-SAFE

Not applicable

DTC CONFIRMATION PROCEDURE

1. PRECONDITIONING

If DTC Confirmation Procedure has been previously conducted, always perform the following procedure before conducting the next test.

1. Turn ignition switch OFF and wait at least 10 seconds.
2. Turn ignition switch ON.
3. Turn ignition switch OFF and wait at least 10 seconds.

TESTING CONDITION:

Before performing the following procedure, confirm that battery voltage is more than 11 V at idle.

>> GO TO 2.

2. PERFORM DTC CONFIRMATION PROCEDURE FOR MALFUNCTION A

Ⓜ With CONSULT

1. Start engine and warm it up to normal operating temperature.
2. Let it idle for 2 minutes.
3. Check 1st trip DTC.

Is 1st trip DTC detected?

- YES >> Proceed to [EC-230, "Diagnosis Procedure"](#).
- NO-1 >> With CONSULT: GO TO 3.
- NO-2 >> Without CONSULT: GO TO 7.

3. CHECK AIR FUEL RATIO (A/F) SENSOR 1 FUNCTION

1. Select "A/F SEN1 (B1)" in "DATA MONITOR" mode of "ENGINE" using CONSULT.
2. Check "A/F SEN1 (B1)" indication.

Does the indication fluctuates around 2.2 V?

- YES >> GO TO 4.
- NO >> Proceed to [EC-230, "Diagnosis Procedure"](#).

4. PERFORM DTC CONFIRMATION PROCEDURE FOR MALFUNCTION B-1

1. Select "A/F SEN1 (B1) P1276" of "A/F SEN1" in "DTC WORK SUPPORT" mode of "ENGINE" using CONSULT.
2. Touch "START".
3. When the following conditions are met, "TESTING" will be displayed on the CONSULT screen.

# P0130 A/F SENSOR 1

< DTC/CIRCUIT DIAGNOSIS >

[QR25DE]

ENG SPEED	1,000 - 3,200 rpm
VHCL SPEED SE	More than 64 km/h (40 mph)
B/FUEL SCHDL	1.0 - 8.0 msec
Selector lever	D position

If "TESTING" is not displayed after 20 seconds, retry from step 2.

**CAUTION:**

**Always drive vehicle at a safe speed.**

Is "TESTING" displayed on CONSULT screen?

YES >> GO TO 5.

NO >> Check A/F sensor 1 function again. GO TO 2.

## 5. PERFORM DTC CONFIRMATION PROCEDURE FOR MALFUNCTION B-2

Release accelerator pedal fully.

**NOTE:**

Never apply brake during releasing the accelerator pedal.

Which does "TESTING" change to?

COMPLETED >> GO TO 6.

OUT OF CONDITION >> Retry DTC CONFIRMATION PROCEDURE. GO TO 3.

## 6. PERFORM DTC CONFIRMATION PROCEDURE FOR MALFUNCTION B-3

Touch "SELF-DIAG RESULT"

Which is displayed on CONSULT screen?

YES >> INSPECTION END

NO >> Proceed to [EC-230, "Diagnosis Procedure"](#).

## 7. PERFORM COMPONENT FUNCTION CHECK FOR MALFUNCTION B

 With GST

1. Start engine and warm it up to normal operating temperature.
2. Drive the vehicle at a speed of 80 km/h (50 MPH) for a few minutes in the suitable gear position.
3. Shift the selector lever to the D position, then release the accelerator pedal fully until the vehicle speed decreases to 50 km/h (31 MPH).

**CAUTION:**

**Always drive vehicle at a safe speed.**

**NOTE:**

Never apply brake during releasing the accelerator pedal.

4. Repeat steps 2 to 3 for five times.
5. Stop the vehicle and turn ignition switch OFF.
6. Wait at least 10 seconds and restart engine.
7. Repeat steps 2 to 3 for five times.
8. Stop the vehicle.
9. Check 1st trip DTC.

Is 1st trip DTC detected?

YES >> Proceed to [EC-230, "Diagnosis Procedure"](#).

NO >> INSPECTION END

## Diagnosis Procedure

INFOID:000000011277980

### 1. CHECK AIR FUEL RATIO (A/F) SENSOR 1 POWER SUPPLY

1. Turn ignition switch OFF.
2. Disconnect A/F sensor 1 harness connector.
3. Turn ignition switch ON.
4. Check the voltage between A/F sensor 1 harness connector and ground.

# P0130 A/F SENSOR 1

< DTC/CIRCUIT DIAGNOSIS >

[QR25DE]

+		-	Voltage
A/F sensor 1			
Connector	Terminal		
F18	4	Ground	Battery voltage

Is the inspection result normal?

- YES >> GO TO 3.
- NO >> GO TO 2.

## 2. CHECK AIR FUEL RATIO (A/F) SENSOR 1 POWER SUPPLY CIRCUIT

1. Turn ignition switch OFF.
2. Disconnect IPDM E/R harness connector.
3. Check the continuity between A/F sensor 1 harness connector and IPDM E/R harness connector.

+		-		Continuity
A/F sensor 1		IPDM E/R		
Connector	Terminal	Connector	Terminal	
F18	4	F35	75	Existed

4. Also check harness for short to ground.

Is the inspection result normal?

- YES >> Perform the trouble diagnosis for power supply circuit.
- NO >> Repair or replace error-detected parts.

## 3. CHECK A/F SENSOR 1 INPUT SIGNAL CIRCUIT

1. Turn ignition switch OFF.
2. Disconnect ECM harness connector.
3. Check the continuity between A/F sensor 1 harness connector and ECM harness connector.

+		-		Continuity
A/F sensor 1		ECM		
Connector	Terminal	Connector	Terminal	
F18	1	F51	41	Existed
	2		45	

4. Check the continuity between A/F sensor 1 harness connector and ground, or ECM harness connector and ground.

+		-	Continuity
A/F sensor 1			
Connector	Terminal		
F18	1	Ground	Not existed
	2		

+		-	Continuity
ECM			
Connector	Terminal		
F51	41	Ground	Not existed
	45		

5. Also check harness for short to power.

Is the inspection result normal?

## P0130 A/F SENSOR 1

[QR25DE]

< DTC/CIRCUIT DIAGNOSIS >

---

- YES >> GO TO 4.
- NO >> Repair or replace error-detected parts.

### 4. CHECK INTERMITTENT INCIDENT

---

Perform [GI-44. "Intermittent Incident"](#).

Is the inspection result normal?

- YES >> GO TO 5.
- NO >> Repair or replace error-detected parts.

### 5. REPLACE AIR FUEL RATIO (A/F) SENSOR 1

---

Replace air fuel ratio (A/F) sensor 1. Refer to [EM-32. "Exploded View"](#).

#### **CAUTION:**

- **Discard any sensor which has been dropped from a height of more than 0.5 m (19.7 in) onto a hard surface such as a concrete floor; use a new one.**
- **Before installing new sensor, clean exhaust system threads using Oxygen Sensor Thread Cleaner [commercial service tool (J-43897-18 or J43897-12)] and approved Anti-seize Lubricant (commercial service tool).**

>> INSPECTION END



# P0131 A/F SENSOR 1

< DTC/CIRCUIT DIAGNOSIS >

[QR25DE]

## P0131 A/F SENSOR 1

### DTC Description

INFOID:0000000011277981

### DTC DETECTION LOGIC

To judge the malfunction, the diagnosis checks that the A/F signal computed by ECM from the A/F sensor 1 signal is not inordinately low.

DTC No.	CONSULT screen terms (Trouble diagnosis content)	DTC detecting condition
P0131	A/F SENSOR1 (B1) (O2 sensor circuit low voltage bank 1 sensor 1)	The A/F signal computed by ECM from the A/F sensor 1 signal is constantly approx. 0 V.

### POSSIBLE CAUSE

- Harness or connectors (A/F sensor 1 circuit is open or shorted.)
- A/F sensor 1

### FAIL-SAFE

Not applicable

### DTC CONFIRMATION PROCEDURE

#### 1. PRECONDITIONING

If DTC Confirmation Procedure has been previously conducted, always perform the following procedure before conducting the next test.

1. Turn ignition switch OFF and wait at least 10 seconds.
2. Turn ignition switch ON.
3. Turn ignition switch OFF and wait at least 10 seconds.

#### TESTING CONDITION:

Before performing the following procedure, confirm that battery voltage is more than 10.5 V at idle.

>> GO TO 2.

#### 2. CHECK A/F SENSOR FUNCTION

##### Ⓜ With CONSULT

1. Start engine and warm it up to normal operating temperature.
2. Select "A/F SEN1 (B1)" in "DATA MONITOR" mode of "ENGINE" using CONSULT.
3. Check "A/F SEN1 (B1)" indication.

##### Ⓜ With GST

Follow the procedure "With CONSULT" above.

Is the indication constantly approx. 0 V?

- YES >> Proceed to [EC-234, "Diagnosis Procedure"](#).  
NO >> GO TO 3.

#### 3. PERFORM DTC CONFIRMATION PROCEDURE

##### Ⓜ With CONSULT

1. Turn ignition switch OFF, wait at least 10 seconds and then restart engine.
2. Drive and accelerate vehicle to more than 40 km/h (25 MPH) within 20 seconds after restarting engine.

#### CAUTION:

**Always drive vehicle at a safe speed.**

3. Maintain the following conditions for about 20 consecutive seconds.

ENG SPEED	1,000 - 3,200 rpm
VHCL SPEED SE	More than 40 km/h (25 mph)
B/FUEL SCHDL	1.5 - 9.0 msec
Selector lever	Suitable position

#### NOTE:

# P0131 A/F SENSOR 1

[QR25DE]

## < DTC/CIRCUIT DIAGNOSIS >

- Keep the accelerator pedal as steady as possible during the cruising.
- If this procedure is not completed within 1 minute after restarting engine at step 1, return to step 1.

4. Check 1st trip DTC.

 With GST

Follow the procedure "With CONSULT" above.

Is 1st trip DTC detected?

- YES >> Proceed to [EC-234. "Diagnosis Procedure"](#).  
NO >> INSPECTION END

## Diagnosis Procedure

INFOID:000000011277982

### 1. CHECK AIR FUEL RATIO (A/F) SENSOR 1 POWER SUPPLY

1. Turn ignition switch OFF.
2. Disconnect A/F sensor 1 harness connector.
3. Turn ignition switch ON.
4. Check the voltage between A/F sensor 1 harness connector and ground.

+		-	Voltage
A/F sensor 1			
Connector	Terminal		
F18	4	Ground	Battery voltage

Is the inspection result normal?

- YES >> GO TO 3.  
NO >> GO TO 2.

### 2. CHECK AIR FUEL RATIO (A/F) SENSOR 1 POWER SUPPLY CIRCUIT

1. Turn ignition switch OFF.
2. Disconnect IPDM E/R harness connector.
3. Check the continuity between A/F sensor 1 harness connector and IPDM E/R harness connector.

+		-		Continuity
A/F sensor 1		IPDM E/R		
Connector	Terminal	Connector	Terminal	
F18	4	F35	75	Existed

4. Also check harness for short to ground.

Is the inspection result normal?

- YES >> Perform the trouble diagnosis for power supply circuit.  
NO >> Repair or replace error-detected parts.

### 3. CHECK A/F SENSOR 1 INPUT SIGNAL CIRCUIT

1. Turn ignition switch OFF.
2. Disconnect ECM harness connector.
3. Check the continuity between A/F sensor 1 harness connector and ECM harness connector.

+		-		Continuity
A/F sensor 1		ECM		
Connector	Terminal	Connector	Terminal	
F18	1	F51	41	Existed
	2		45	

4. Check the continuity between A/F sensor 1 harness connector and ground, or ECM harness connector and ground.

# P0131 A/F SENSOR 1

< DTC/CIRCUIT DIAGNOSIS >

[QR25DE]

+		-	Continuity
A/F sensor 1			
Connector	Terminal		
F18	1	Ground	Not existed
	2		

+		-	Continuity
ECM			
Connector	Terminal		
F51	41	Ground	Not existed
	45		

5. Also check harness for short to power.

Is the inspection result normal?

YES >> GO TO 4.

NO >> Repair or replace error-detected parts.

## 4.CHECK INTERMITTENT INCIDENT

Perform [GI-44. "Intermittent Incident"](#).

Is the inspection result normal?

YES >> GO TO 5.

NO >> Repair or replace error-detected parts.

## 5.REPLACE AIR FUEL RATIO (A/F) SENSOR 1

Replace air fuel ratio (A/F) sensor 1. Refer to [EM-32. "Exploded View"](#).

### CAUTION:

- Discard any sensor which has been dropped from a height of more than 0.5 m (19.7 in) onto a hard surface such as a concrete floor; use a new one.
- Before installing new sensor, clean exhaust system threads using Oxygen Sensor Thread Cleaner [commercial service tool (J-43897-18 or J43897-12)] and approved Anti-seize Lubricant (commercial service tool).

>> INSPECTION END

A  
EC  
C  
D  
E  
F  
G  
H  
I  
J  
K  
L  
M  
N  
O  
P

P0132 A/F SENSOR 1

DTC Description

INFOID:000000011277983

DTC DETECTION LOGIC

To judge the malfunction, the diagnosis checks that the A/F signal computed by ECM from the A/F sensor 1 signal is not inordinately high.

DTC No.	CONSULT screen terms (Trouble diagnosis content)	DTC detecting condition
P0132	A/F SENSOR1 (B1) (O2 sensor circuit high voltage bank 1 sensor 1)	The A/F signal computed by ECM from the A/F sensor 1 signal is constantly approx. 5 V.

POSSIBLE CAUSE

- Harness or connectors (A/F sensor 1 circuit is open or shorted.)
- A/F sensor 1

FAIL-SAFE

Not applicable

DTC CONFIRMATION PROCEDURE

1. PRECONDITIONING

If DTC Confirmation Procedure has been previously conducted, always perform the following procedure before conducting the next test.

1. Turn ignition switch OFF and wait at least 10 seconds.
2. Turn ignition switch ON.
3. Turn ignition switch OFF and wait at least 10 seconds.

**TESTING CONDITION:**

**Before performing the following procedure, confirm that battery voltage is more than 10.5 V at idle.**

>> GO TO 2.

2. CHECK A/F SENSOR FUNCTION

 With CONSULT

1. Start engine and warm it up to normal operating temperature.
2. Select "A/F SEN1 (B1)" in "DATA MONITOR" mode of "ENGINE" using CONSULT.
3. Check "A/F SEN1 (B1)" indication.

 With GST

Follow the procedure "With CONSULT" above.

Is the indication constantly approx. 5 V?

- YES >> Proceed to [EC-237, "Diagnosis Procedure"](#).  
 NO >> GO TO 3.

3. PERFORM DTC CONFIRMATION PROCEDURE

 With CONSULT

1. Turn ignition switch OFF, wait at least 10 seconds and then restart engine.
2. Drive and accelerate vehicle to more than 40 km/h (25 MPH) within 20 seconds after restarting engine.

**CAUTION:**

**Always drive vehicle at a safe speed.**

3. Maintain the following conditions for about 20 consecutive seconds.

ENG SPEED	1,000 - 3,200 rpm
VHCL SPEED SE	More than 40 km/h (25 mph)
B/FUEL SCHDL	1.5 - 9.0 msec
Selector lever	Suitable position

**NOTE:**

# P0132 A/F SENSOR 1

[QR25DE]

## < DTC/CIRCUIT DIAGNOSIS >

- **Keep the accelerator pedal as steady as possible during the cruising.**
- **If this procedure is not completed within 1 minute after restarting engine at step 1, return to step 1.**

4. Check 1st trip DTC.

 With GST

Follow the procedure "With CONSULT" above.

Is 1st trip DTC is detected?

- YES >> Proceed to [EC-237. "Diagnosis Procedure"](#).  
 NO >> INSPECTION END

## Diagnosis Procedure

INFOID:000000011277984

### 1. CHECK AIR FUEL RATIO (A/F) SENSOR 1 POWER SUPPLY

1. Turn ignition switch OFF.
2. Disconnect A/F sensor 1 harness connector.
3. Turn ignition switch ON.
4. Check the voltage between A/F sensor 1 harness connector and ground.

+		-	Voltage
A/F sensor 1			
Connector	Terminal		
F18	4	Ground	Battery voltage

Is the inspection result normal?

- YES >> GO TO 3.  
 NO >> GO TO 2.

### 2. CHECK AIR FUEL RATIO (A/F) SENSOR 1 POWER SUPPLY CIRCUIT

1. Turn ignition switch OFF.
2. Disconnect IPDM E/R harness connector.
3. Check the continuity between A/F sensor 1 harness connector and IPDM E/R harness connector.

+		-		Continuity
A/F sensor 1		IPDM E/R		
Connector	Terminal	Connector	Terminal	
F18	4	F35	75	Existed

4. Also check harness for short to ground.

Is the inspection result normal?

- YES >> Perform the trouble diagnosis for power supply circuit.  
 NO >> Repair or replace error-detected parts.

### 3. CHECK A/F SENSOR 1 INPUT SIGNAL CIRCUIT

1. Turn ignition switch OFF.
2. Disconnect ECM harness connector.
3. Check the continuity between A/F sensor 1 harness connector and ECM harness connector.

+		-		Continuity
A/F sensor 1		ECM		
Connector	Terminal	Connector	Terminal	
F18	1	F51	41	Existed
	2		45	

4. Check the continuity between A/F sensor 1 harness connector and ground, or ECM harness connector and ground.

# P0132 A/F SENSOR 1

[QR25DE]

< DTC/CIRCUIT DIAGNOSIS >

+		-	Continuity
A/F sensor 1			
Connector	Terminal		
F18	1	Ground	Not existed
	2		

+		-	Continuity
ECM			
Connector	Terminal		
F51	41	Ground	Not existed
	45		

5. Also check harness for short to power.

Is the inspection result normal?

YES >> GO TO 4.

NO >> Repair or replace error-detected parts.

## 4. CHECK INTERMITTENT INCIDENT

Perform [GI-44. "Intermittent Incident"](#).

Is the inspection result normal?

YES >> GO TO 5.

NO >> Repair or replace error-detected parts.

## 5. REPLACE AIR FUEL RATIO (A/F) SENSOR 1

Replace air fuel ratio (A/F) sensor 1. Refer to [EM-32. "Exploded View"](#).

### CAUTION:

- Discard any sensor which has been dropped from a height of more than 0.5 m (19.7 in) onto a hard surface such as a concrete floor; use a new one.
- Before installing new sensor, clean exhaust system threads using Oxygen Sensor Thread Cleaner [commercial service tool (J-43897-18 or J43897-12)] and approved Anti-seize Lubricant (commercial service tool).

>> INSPECTION END

P0137 HO2S2

DTC Description

INFOID:000000011277985

DTC DETECTION LOGIC

The heated oxygen sensor 2 has a much longer switching time between rich and lean than the air fuel ratio (A/F) sensor 1. The oxygen storage capacity of the three way catalyst (manifold) causes the longer switching time. To judge the malfunctions of heated oxygen sensor 2, ECM monitors whether the maximum voltage of the sensor is sufficiently high during the various driving condition such as fuel-cut.

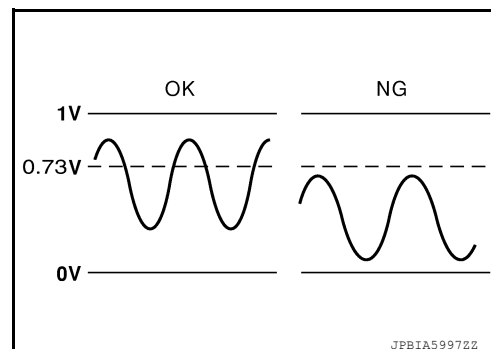

DTC No.	CONSULT screen terms (Trouble diagnosis content)	DTC detecting condition
P0137	HO2S2 (B1) (O2 sensor circuit low voltage bank 1 sensor 2)	The maximum voltage from the heated oxygen sensor 2 is not reached to the specified voltage.

POSSIBLE CAUSE

- Harness or connectors (Heated oxygen sensor 2 circuit is open or shorted.)
- Heated oxygen sensor 2
- Fuel pressure
- Fuel injector
- Intake air leaks

FAIL-SAFE

Not applicable

DTC CONFIRMATION PROCEDURE

1.INSPECTION START

Do you have CONSULT?

Do you have CONSULT?

YES >> GO TO 2.

NO >> GO TO 5.

2.PRECONDITIONING

If DTC Confirmation Procedure has been previously conducted, always perform the following procedure before conducting the next test.

1. Turn ignition switch OFF and wait at least 10 seconds.
2. Turn ignition switch ON.
3. Turn ignition switch OFF and wait at least 10 seconds.

**TESTING CONDITION:**

**For better results, perform “DTC WORK SUPPORT” at a temperature of 0 to 30°C (32 to 86°F).**

>> GO TO 3.

3.PERFORM DTC CONFIRMATION PROCEDURE

Ⓜ With CONSULT

1. Turn ignition switch ON and select “DATA MONITOR” mode of “ENGINE” using CONSULT.
2. Start engine and warm it up to normal operating temperature.
3. Turn ignition switch OFF and wait at least 10 seconds.
4. Start engine and keep the engine speed between 3,500 and 4,000 rpm for at least 1 minute under no load.

< DTC/CIRCUIT DIAGNOSIS >

5. Let engine idle for 1 minute.
6. Make sure that "COOLAN TEMP/S" indicates more than 70°C (158°F).  
If not, warm up engine and go to next step when "COOLAN TEMP/S" indication reaches 70°C (158°F).
7. Open engine hood.
8. Select "HO2S2 (B1) P1147" of "HO2S2" in "DTC WORK SUPPORT" mode of "ENGINE" using CONSULT.
9. Follow the instruction of CONSULT.

**NOTE:**

It will take at most 10 minutes until "COMPLETED" is displayed.

10. Touch "SELF-DIAG RESULT".

Which is displayed on CONSULT screen?

- OK >> INSPECTION END
- NG >> Proceed to [EC-241, "Diagnosis Procedure"](#).
- CAN NOT BE DIAGNOSED>>GO TO 4.

**4.PERFORM DTC CONFIRMATION PROCEDURE AGAIN**

1. Turn ignition switch OFF and leave the vehicle in a cool place (soak the vehicle).
2. Perform DTC CONFIRMATION PROCEDURE again.

>> GO TO 3.

**5.PERFORM COMPONENT FUNCTION CHECK-1**

Without CONSULT

1. Start engine and warm it up to normal operating temperature.
2. Turn ignition switch OFF and wait at least 10 seconds.
3. Start engine and keep the engine speed between 3,500 and 4,000 rpm for at least 1 minute under no load.
4. Let engine idle for 1 minute.
5. Check the voltage between ECM harness connector and ground as per the following condition.

ECM			Condition	Voltage
Connector	+	-		
	Terminal			
F51	22	23	Revving up to 4,000 rpm under no load at least 10 times	The voltage should be above 0.73 V at least once during this procedure.

Is the inspection result normal?

- YES >> INSPECTION END
- NO >> GO TO 6.

**6.PERFORM COMPONENT FUNCTION CHECK-2**

Check the voltage between ECM harness connector and ground as per the following condition.

ECM			Condition	Voltage
Connector	+	-		
	Terminal			
F51	22	23	Keeping engine speed at idle for 10 minutes	The voltage should be above 0.73 V at least once during this procedure.

Is the inspection result normal?

- YES >> INSPECTION END
- NO >> GO TO 7.

**7.PERFORM COMPONENT FUNCTION CHECK-3**

Check the voltage between ECM harness connector and ground as per the following condition.



ECM			Condition	Voltage
Connector	+	-		
	Terminal			
F51	22	23	Coasting from 80 km/h (50 MPH) in D position	The voltage should be above 0.73 V at least once during this procedure.

Is the inspection result normal?

- YES >> INSPECTION END
- NO >> Proceed to [EC-241, "Diagnosis Procedure"](#).

Diagnosis Procedure

INFOID:0000000011277986

1. CLEAR THE MIXTURE RATIO SELF-LEARNING VALUE

1. Clear the mixture ratio self-learning value. Refer to [EC-146, "Work Procedure"](#).
2. Run engine for at least 10 minutes at idle speed.

Is the 1st trip DTC P0171 detected? Is it difficult to start engine?

- YES >> Perform trouble diagnosis for DTC P0171. Refer to [EC-263, "DTC Description"](#).
- NO >> GO TO 2.

2. CHECK HO2S2 GROUND CIRCUIT

1. Turn ignition switch OFF.
2. Disconnect heated oxygen sensor 2 (HO2S2) harness connector.
3. Disconnect ECM harness connector.
4. Check the continuity between HO2S2 harness connector and ECM harness connector.

+		-		Continuity
HO2S2		ECM		
Connector	Terminal	Connector	Terminal	
F21	1	F51	23	Existed

5. Also check harness for short to power.

Is the inspection result normal?

- YES >> GO TO 3.
- NO >> Repair or replace error-detected parts.

3. CHECK HO2S2 INPUT SIGNAL CIRCUIT

1. Check the continuity between HO2S2 harness connector and ECM harness connector.

+		-		Continuity
HO2S2		ECM		
Connector	Terminal	Connector	Terminal	
F21	2	F51	22	Existed

2. Check the continuity between HO2S2 harness connector and ground, or ECM harness connector and ground.

+		-	Continuity
HO2S2			
Connector	Terminal		
F21	2	Ground	Not existed

+		-	Continuity
ECM			
Connector	Terminal		
F51	22	Ground	Not existed

3. Also check harness for short to power.

Is the inspection result normal?

- YES >> GO TO 4.
- NO >> Repair or replace error-detected parts.

**4.CHECK HEATED OXYGEN SENSOR 2**

Check the heated oxygen sensor 2. Refer to [EC-242, "Component Inspection"](#).

Is the inspection result normal?

- YES >> Check intermittent incident. Refer to [GI-44, "Intermittent Incident"](#).
- NO >> GO TO 5.

**5.REPLACE HEATED OXYGEN SENSOR 2**

Replace heated oxygen sensor 2.

**CAUTION:**

- Discard any sensor which has been dropped from a height of more than 0.5 m (19.7 in) onto a hard surface such as a concrete floor; use a new one.
- Before installing new sensor, clean exhaust system threads using Oxygen Sensor Thread Cleaner [commercial service tool (J-43897-18 or J43897-12)] and approved Anti-seize Lubricant (commercial service tool).

>> INSPECTION END

**Component Inspection**

INFOID:000000011277987

**1.INSPECTION START**

Do you have CONSULT?

Do you have CONSULT?

- YES >> GO TO 2.
- NO >> GO TO 3.

**2.CHECK HEATED OXYGEN SENSOR 2**

ⓅWith CONSULT

1. Turn ignition switch ON and select "DATA MONITOR" mode of "ENGINE" using CONSULT.
2. Start engine and warm it up to normal operating temperature.
3. Turn ignition switch OFF and wait at least 10 seconds.
4. Start engine and keep the engine speed between 3,500 and 4,000 rpm for at least 1 minute under no load.
5. Let engine idle for 1 minute.
6. Select "FUEL INJECTION" in "ACTIVE TEST" mode of "ENGINE" using CONSULT, and select "HO2S2 (B1)" as the monitor item with CONSULT.
7. Check "HO2S2 (B1)" at idle speed when adjusting "FUEL INJECTION" to  $\pm 25\%$ .

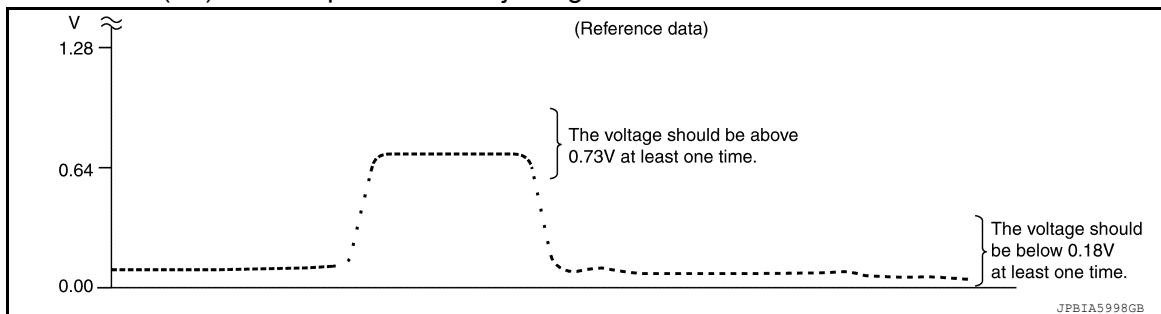

"HO2S2 (B1)" should be above 0.73 V at least once when the "FUEL INJECTION" is + 25%.  
 "HO2S2 (B1)" should be below 0.18 V at least once when the "FUEL INJECTION" is - 25%.

< DTC/CIRCUIT DIAGNOSIS >

Is the inspection result normal?

- YES >> INSPECTION END
- NO >> GO TO 6.

3.CHECK HEATED OXYGEN SENSOR 2-1

⊗ Without CONSULT

1. Start engine and warm it up to normal operating temperature.
2. Turn ignition switch OFF and wait at least 10 seconds.
3. Start engine and keep the engine speed between 3,500 and 4,000 rpm for at least 1 minute under no load.
4. Let engine idle for 1 minute.
5. Check the voltage between ECM harness connector and ground as per the following condition.

ECM			Condition	Voltage
Connector	+	-		
	Terminal			
F51	22	23	Revving up to 4,000 rpm under no load at least 10 times	The voltage should be above 0.73 V at least once during this procedure. The voltage should be below 0.18 V at least once during this procedure.

Is the inspection result normal?

- YES >> INSPECTION END
- NO >> GO TO 4.

4.CHECK HEATED OXYGEN SENSOR 2-2

Check the voltage between ECM harness connector and ground as per the following condition.

ECM			Condition	Voltage
Connector	+	-		
	Terminal			
F51	22	23	Keeping engine speed at idle for 10 minutes	The voltage should be above 0.73 V at least once during this procedure. The voltage should be below 0.18 V at least once during this procedure.

Is the inspection result normal?

- YES >> INSPECTION END
- NO >> GO TO 5.

5.CHECK HEATED OXYGEN SENSOR 2-3

Check the voltage between ECM harness connector and ground as per the following condition.

ECM			Condition	Voltage
Connector	+	-		
	Terminal			
F51	22	23	Coasting from 80 km/h (50 MPH) in D position	The voltage should be above 0.73 V at least once during this procedure. The voltage should be below 0.18 V at least once during this procedure.

Is the inspection result normal?

- YES >> INSPECTION END
- NO >> GO TO 6.

6.REPLACE HEATED OXYGEN SENSOR 2

Replace heated oxygen sensor 2. Refer to [EX-5. "Exploded View"](#).

**CAUTION:**

A  
EC  
C  
D  
E  
F  
G  
H  
I  
J  
K  
L  
M  
N  
O  
P

## P0137 HO2S2

< DTC/CIRCUIT DIAGNOSIS >

[QR25DE]

- Discard any sensor which has been dropped from a height of more than 0.5 m (19.7 in) onto a hard surface such as a concrete floor; use a new one.
- Before installing new sensor, clean exhaust system threads using Oxygen Sensor Thread Cleaner [commercial service tool (J-43897-18 or J43897-12)] and approved Anti-seize Lubricant (commercial service tool).

>> INSPECTION END

P0138 HO2S2

DTC Description

INFOID:0000000011277988

DTC DETECTION LOGIC

The heated oxygen sensor 2 has a much longer switching time between rich and lean than the air fuel ratio (A/F) sensor 1. The oxygen storage capacity of the three way catalyst (manifold) causes the longer switching time.

**MALFUNCTION A**

To judge the malfunctions of heated oxygen sensor 2, ECM monitors whether the voltage is unusually high during the various driving condition such as fuel-cut.

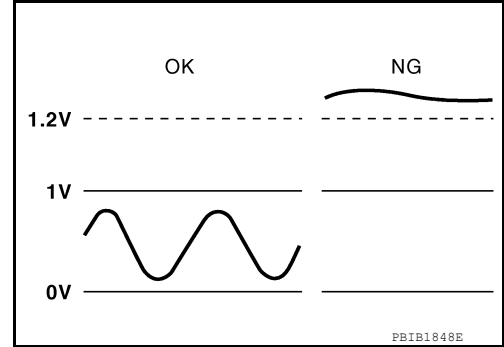

**MALFUNCTION B**

To judge the malfunctions of heated oxygen sensor 2, ECM monitors whether the minimum voltage of sensor is sufficiently low during the various driving condition such as fuel-cut.

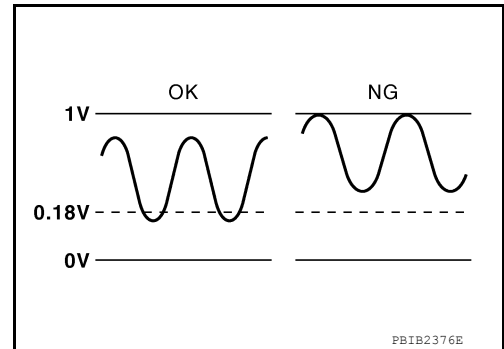

DTC No.	CONSULT screen terms (Trouble diagnosis content)	DTC detecting condition	
P0138	HO2S2 (B1) (O2 sensor circuit high voltage bank 1 sensor 2)	A	An excessively high voltage from the sensor is sent to ECM.
		B	The minimum voltage from the sensor is not reached to the specified voltage.

POSSIBLE CAUSE

DTC P0138 - A

- Harness or connectors (The sensor circuit is open or shorted.)
- Heated oxygen sensor 2

DTC P0138 - B

- Harness or connectors (The sensor circuit is open or shorted.)
- Heated oxygen sensor 2
- Fuel pressure
- Fuel injector

FAIL-SAFE

Not applicable

DTC CONFIRMATION PROCEDURE

1. PRECONDITIONING

A  
EC  
C  
D  
E  
F  
G  
H  
I  
J  
K  
L  
M  
N  
O  
P

## &lt; DTC/CIRCUIT DIAGNOSIS &gt;

If DTC Confirmation Procedure has been previously conducted, always perform the following procedure before conducting the next test.

1. Turn ignition switch OFF and wait at least 10 seconds.
2. Turn ignition switch ON.
3. Turn ignition switch OFF and wait at least 10 seconds.

>> GO TO 2.

**2. PERFORM DTC CONFIRMATION PROCEDURE FOR MALFUNCTION A**

1. Start engine and warm it up to normal operating temperature.
2. Turn ignition switch OFF and wait at least 10 seconds.
3. Start engine and keep the engine speed between 3,500 and 4,000 rpm for at least 1 minute under no load.
4. Let engine idle for 2 minutes.
5. Check 1st trip DTC.

Is 1st trip DTC detected?

YES >> Proceed to [EC-247, "Diagnosis Procedure"](#).

NO-1 >> With CONSULT: GO TO 3.

NO-2 >> Without CONSULT: GO TO 5.

**3. PERFORM DTC CONFIRMATION PROCEDURE FOR MALFUNCTION B****NOTE:**

**For better results, perform "DTC WORK SUPPORT" at a temperature of 0 to 30°C (32 to 86°F).**

1. Turn ignition switch ON and select "DATA MONITOR" mode of "ENGINE" using CONSULT.
2. Start engine and warm it up to normal operating temperature.
3. Turn ignition switch OFF and wait at least 10 seconds.
4. Start engine and keep the engine speed between 3,500 and 4,000 rpm for at least 1 minute under no load.
5. Let engine idle for 1 minute.
6. Make sure that "COOLAN TEMP/S" indication is more than 70°C (158°F).  
If not, warm up engine and go to next step when "COOLAN TEMP/S" indication reaches 70°C (158°F).
7. Open engine hood.
8. Select "HO2S2 (B1) P1146" of "HO2S2" in "DTC WORK SUPPORT" mode of "ENGINE" using CONSULT.
9. Follow the instruction of CONSULT.

**NOTE:**

It will take at most 10 minutes until "COMPLETED" is displayed.

10. Touch "SELF-DIAG RESULT".

Which is displayed on CONSULT

OK >> INSPECTION END

NG >> Proceed to [EC-247, "Diagnosis Procedure"](#).

CAN NOT BE DIAGNOSED>>GO TO 4.

**4. PERFORM DTC CONFIRMATION PROCEDURE FOR MALFUNCTION B AGAIN**

1. Turn ignition switch OFF and leave the vehicle in a cool place (soak the vehicle).
2. Perform DTC confirmation procedure again.

>> GO TO 3.

**5. PERFORM COMPONENT FUNCTION CHECK-1**

⊗ Without CONSULT

1. Start engine and warm it up to normal operating temperature.
2. Turn ignition switch OFF and wait at least 10 seconds.
3. Start engine and keep the engine speed between 3,500 and 4,000 rpm for at least 1 minute under no load.
4. Let engine idle for 1 minute.
5. Check the voltage between ECM harness connector and ground as per the following condition.

ECM			Condition	Voltage
Connector	+	-		
	Terminal			
F51	22	23	Revving up to 4,000 rpm under no load at least 10 times	The voltage should be above 0.73 V at least once during this procedure.

Is the inspection result normal?

- YES >> INSPECTION END
- NO >> GO TO 6.

### 6.PERFORM COMPONENT FUNCTION CHECK-2

Check the voltage between ECM harness connector and ground as per the following condition.

ECM			Condition	Voltage
Connector	+	-		
	Terminal			
F51	22	23	Keeping engine speed at idle for 10 minutes	The voltage should be above 0.73 V at least once during this procedure.

Is the inspection result normal?

- YES >> INSPECTION END
- NO >> GO TO 7.

### 7.PERFORM COMPONENT FUNCTION CHECK-3

Check the voltage between ECM harness connector and ground as per the following condition.

ECM			Condition	Voltage
Connector	+	-		
	Terminal			
F51	22	23	Coasting from 80 km/h (50 MPH) in D position	The voltage should be above 0.73 V at least once during this procedure.

Is the inspection result normal?

- YES >> INSPECTION END
- NO >> Proceed to [EC-247, "Diagnosis Procedure"](#).

## Diagnosis Procedure

INFOID:00000001127989

### 1.INSPECTION START

Confirm the detected malfunction (A or B). Refer to [EC-245, "DTC Description"](#).

Which malfunction is detected?

- A >> GO TO 2.
- B >> GO TO 7.

### 2.CHECK HO2S2 CONNECTOR FOR WATER

1. Turn ignition switch OFF.
2. Disconnect heated oxygen sensor 2 harness connector.
3. Check connectors for water.

**Water should not exist.**

Is the inspection result normal?

- YES >> GO TO 3.
- NO >> Repair or replace error-detected parts.

### 3.CHECK HO2S2 GROUND CIRCUIT

< DTC/CIRCUIT DIAGNOSIS >

1. Disconnect ECM harness connector.
2. Check the continuity between HO2S2 harness connector and ECM harness connector.

+		-		Continuity
HO2S2		ECM		
Connector	Terminal	Connector	Terminal	
F21	1	F51	23	Existed

3. Also check harness for short to power.

Is the inspection result normal?

- YES >> GO TO 4.  
 NO >> Repair or replace error-detected parts.

**4.CHECK HO2S2 INPUT SIGNAL CIRCUIT**

1. Check the continuity between HO2S2 harness connector and ECM harness connector.

+		-		Continuity
HO2S2		ECM		
Connector	Terminal	Connector	Terminal	
F21	2	F51	22	Existed

2. Check the continuity between HO2S2 harness connector and ground, or ECM harness connector and ground.

+		-	Continuity
HO2S2			
Connector	Terminal		
F21	2	Ground	Not existed

+		-	Continuity
ECM			
Connector	Terminal		
F51	22	Ground	Not existed

3. Also check harness for short to power.

Is the inspection result normal?

- YES >> GO TO 5.  
 NO >> Repair or replace error-detected parts.

**5.CHECK HEATED OXYGEN SENSOR 2**

Check the heated oxygen sensor 2. Refer to [EC-250, "Component Inspection"](#).

Is the inspection result normal?

- YES >> Check intermittent incident. Refer to [GI-44, "Intermittent Incident"](#).  
 NO >> GO TO 6.

**6.REPLACE HEATED OXYGEN SENSOR 2**

Replace heated oxygen sensor 2. Refer to [EX-5, "Exploded View"](#).

**CAUTION:**

- Discard any sensor which has been dropped from a height of more than 0.5 m (19.7 in) onto a hard surface such as a concrete floor; use a new one.
- Before installing new sensor, clean exhaust system threads using Oxygen Sensor Thread Cleaner [commercial service tool (J-43897-18 or J43897-12)] and approved Anti-seize Lubricant (commercial service tool).

>> INSPECTION END



< DTC/CIRCUIT DIAGNOSIS >

**7.** CLEAR THE MIXTURE RATIO SELF-LEARNING VALUE

1. Clear the mixture ratio self-learning value. Refer to [EC-146, "Work Procedure"](#).
2. Run engine for at least 10 minutes at idle speed.

Is the 1st trip DTC P0172 detected? Is it difficult to start engine?

- YES >> Perform trouble diagnosis for DTC P0172. Refer to [EC-268, "DTC Description"](#).  
 NO >> GO TO 8.

**8.** CHECK HO2S2 GROUND CIRCUIT

1. Turn ignition switch OFF.
2. Disconnect heated oxygen sensor 2 harness connector.
3. Disconnect ECM harness connector.
4. Check the continuity between HO2S2 harness connector and ECM harness connector.

+		-		Continuity
HO2S2		ECM		
Connector	Terminal	Connector	Terminal	
F21	1	F51	23	Existed

5. Also check harness for short to ground and to power.

Is the inspection result normal?

- YES >> GO TO 9.  
 NO >> Repair or replace error-detected parts.

**9.** CHECK HO2S2 INPUT SIGNAL CIRCUIT

1. Check the continuity between HO2S2 harness connector and ECM harness connector.

+		-		Continuity
HO2S2		ECM		
Connector	Terminal	Connector	Terminal	
F21	2	F51	22	Existed

2. Check the continuity between HO2S2 harness connector and ground, or ECM harness connector and ground.

+		-	Continuity
HO2S2			
Connector	Terminal		
F21	2	Ground	Not existed

+		-	Continuity
ECM			
Connector	Terminal		
F51	22	Ground	Not existed

3. Also check harness for short to power.

Is the inspection result normal?

- YES >> GO TO 10.  
 NO >> Repair open circuit or short to ground or short to power in harness or connectors.

**10.** CHECK HEATED OXYGEN SENSOR 2

Check the heated oxygen sensor 2. Refer to [EC-250, "Component Inspection"](#).

Is the inspection result normal?

- YES >> Check intermittent incident. Refer to [GI-44, "Intermittent Incident"](#).  
 NO >> GO TO 11.

A  
EC  
C  
D  
E  
F  
G  
H  
I  
J  
K  
L  
M  
N  
O  
P

# 11. REPLACE HEATED OXYGEN SENSOR 2

Replace heated oxygen sensor 2. Refer to [EX-5, "Exploded View"](#).

**CAUTION:**

- Discard any sensor which has been dropped from a height of more than 0.5 m (19.7 in) onto a hard surface such as a concrete floor; use a new one.
- Before installing new sensor, clean exhaust system threads using Oxygen Sensor Thread Cleaner [commercial service tool (J-43897-18 or J43897-12)] and approved Anti-seize Lubricant (commercial service tool).

>> INSPECTION END

## Component Inspection

INFOID:000000011277990

### 1. INSPECTION START

Do you have CONSULT?

Do you have CONSULT?

- YES >> GO TO 2.
- NO >> GO TO 3.

### 2. CHECK HEATED OXYGEN SENSOR 2

Ⓢ With CONSULT

1. Turn ignition switch ON and select "DATA MONITOR" mode of "ENGINE" using CONSULT.
2. Start engine and warm it up to normal operating temperature.
3. Turn ignition switch OFF and wait at least 10 seconds.
4. Start engine and keep the engine speed between 3,500 and 4,000 rpm for at least 1 minute under no load.
5. Let engine idle for 1 minute.
6. Select "FUEL INJECTION" in "ACTIVE TEST" mode of "ENGINE" using CONSULT, and select "HO2S2 (B1)" as the monitor item with CONSULT.
7. Check "HO2S2 (B1)" at idle speed when adjusting "FUEL INJECTION" to  $\pm 25\%$ .

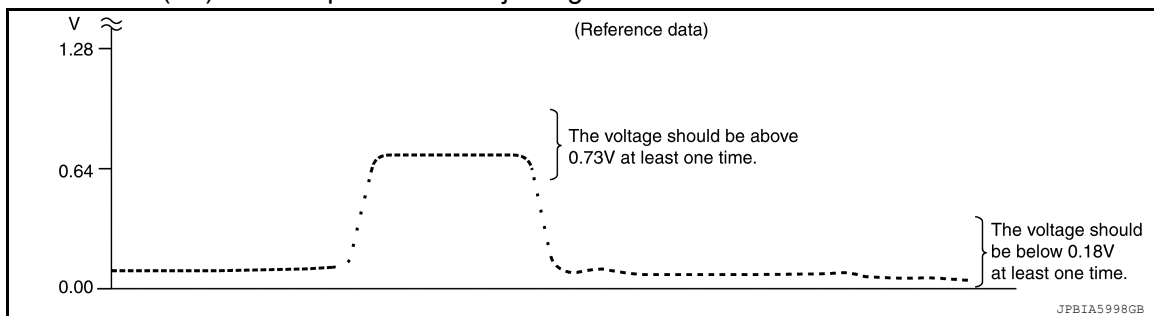

**"HO2S2 (B1)" should be above 0.73 V at least once when the "FUEL INJECTION" is + 25%.**  
**"HO2S2 (B1)" should be below 0.18 V at least once when the "FUEL INJECTION" is - 25%.**

Is the inspection result normal?

- YES >> INSPECTION END
- NO >> GO TO 6.

### 3. CHECK HEATED OXYGEN SENSOR 2-1

ⓧ Without CONSULT

1. Start engine and warm it up to normal operating temperature.
2. Turn ignition switch OFF and wait at least 10 seconds.
3. Start engine and keep the engine speed between 3,500 and 4,000 rpm for at least 1 minute under no load.
4. Let engine idle for 1 minute.
5. Check the voltage between ECM harness connector and ground as per the following condition.

ECM			Condition	Voltage
Connector	+	-		
	Terminal			
F51	22	23	Revving up to 4,000 rpm under no load at least 10 times	The voltage should be above 0.73 V at least once during this procedure. The voltage should be below 0.18 V at least once during this procedure.

Is the inspection result normal?

YES >> INSPECTION END  
 NO >> GO TO 4.

**4.CHECK HEATED OXYGEN SENSOR 2-2**

Check the voltage between ECM harness connector and ground as per the following condition.

ECM			Condition	Voltage
Connector	+	-		
	Terminal			
F51	22	23	Keeping engine speed at idle for 10 minutes	The voltage should be above 0.73 V at least once during this procedure. The voltage should be below 0.18 V at least once during this procedure.

Is the inspection result normal?

YES >> INSPECTION END  
 NO >> GO TO 5.

**5.CHECK HEATED OXYGEN SENSOR 2-3**

Check the voltage between ECM harness connector and ground as per the following condition.

ECM			Condition	Voltage
Connector	+	-		
	Terminal			
F51	22	23	Coasting from 80 km/h (50 MPH) in D position	The voltage should be above 0.73 V at least once during this procedure. The voltage should be below 0.18 V at least once during this procedure.

Is the inspection result normal?

YES >> INSPECTION END  
 NO >> GO TO 6.

**6.REPLACE HEATED OXYGEN SENSOR 2**

Replace heated oxygen sensor 2. Refer to [EX-5, "Exploded View"](#).

**CAUTION:**

- Discard any sensor which has been dropped from a height of more than 0.5 m (19.7 in) onto a hard surface such as a concrete floor; use a new one.
- Before installing new sensor, clean exhaust system threads using Oxygen Sensor Thread Cleaner [commercial service tool (J-43897-18 or J43897-12)] and approved Anti-seize Lubricant (commercial service tool).

>> INSPECTION END

A  
 EC  
 C  
 D  
 E  
 F  
 G  
 H  
 I  
 J  
 K  
 L  
 M  
 N  
 O  
 P

P0139 HO2S2

DTC Description

INFOID:000000011277991

DTC DETECTION LOGIC

The heated oxygen sensor 2 has a much longer switching time between rich and lean than the air fuel ratio (A/F) sensor 1. The oxygen storage capacity of the three way catalyst 1 causes the longer switching time. To judge the malfunctions of heated oxygen sensor 2, ECM monitors whether the switching response of the sensor's voltage is faster than specified during various driving conditions such as fuel cut.

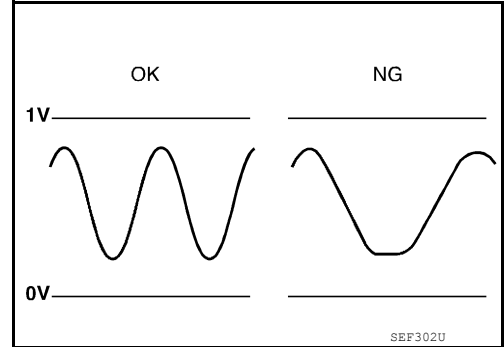

DTC No.	CONSULT screen terms (Trouble diagnosis content)	DTC detecting condition
P0139	HO2S2 (B1) (O2 sensor circuit slow response bank 1 sensor 2)	The switching time between rich and lean of a heated oxygen sensor 2 signal delays more than the specified time computed by ECM.

POSSIBLE CAUSE

- Harness or connectors (The sensor circuit is open or shorted.)
- Heated oxygen sensor 2
- Fuel system
- EVAP system
- Intake air system

FAIL-SAFE

Not applicable

DTC CONFIRMATION PROCEDURE

1.INSPECTION START

Do you have CONSULT?

Do you have CONSULT?

- YES >> GO TO 2.
- NO >> GO TO 7.

2.PRECONDITIONING

If DTC Confirmation Procedure has been previously conducted, always perform the following procedure before conducting the next test.

1. Turn ignition switch OFF and wait at least 10 seconds.
2. Turn ignition switch ON.
3. Turn ignition switch OFF and wait at least 10 seconds.

**TESTING CONDITION:**

**For better results, perform "DTC WORK SUPPORT" at a temperature of 0 to 30°C (32 to 86°F).**

>> GO TO 3.

3.PERFORM DTC CONFIRMATION PROCEDURE

ⓅWith CONSULT

1. Turn ignition switch ON and select "DATA MONITOR" mode of "ENGINE" using CONSULT.
2. Start engine and warm it up to the normal operating temperature.
3. Turn ignition switch OFF and wait at least 10 seconds.
4. Turn ignition switch ON.

< DTC/CIRCUIT DIAGNOSIS >

5. Turn ignition switch OFF and wait at least 10 seconds.
6. Start engine and keep the engine speed between 3,500 and 4,000 rpm for at least 1 minute under no load.
7. Let engine idle for 1 minute.
8. Make sure that "COOLAN TEMP/S" indicates more than 70°C (158°F).
9. Drive the vehicle in a proper at 60 km/h (38MPH) and maintain the speed.

**CAUTION:**

**Always drive vehicle at a safe speed.**

10. Release the accelerator pedal fully at least 5 seconds.

**CAUTION:**

- **Enable engine brake.**
- **Always drive carefully.**
- **Never apply brake when releasing the accelerator pedal.**

11. Repeat step 9 and 10 at least 8 times.
12. Check the following item of "DATA MONITOR".

Data monitor item	Status
HO2 S2 DIAG1 (B1)	CMPLT
HO2 S2 DIAG2 (B1)	

Is "CMPLT" displayed on CONSULT screen?

YES >> GO TO 6.

NO-1: "CMPLT" is not displayed on DIAG 1>>Perform DTC confirmation procedure again.

NO-2: "CMPLT" is not displayed on DIAG 2>>GO TO 4.

**4.PERFORM DTC WORK SUPPORT**

1. Open engine hood.
2. Select "HO2S2 (B1) P0139" in "DTC WORK SUPPORT" mode of "ENGINE" using CONSULT.
3. Start engine and follow the instruction of CONSULT display.

**NOTE:**

It will take at most 10 minutes until "COMPLETED" is displayed.

Is "COMPLETED" displayed on CONSULT screen?

YES >> GO TO 6.

NO >> GO TO 5.

**5.PERFORM DTC CONFIRMATION PROCEDURE AGAIN**

1. Turn ignition switch OFF and leave the vehicle in a cool place (soak the vehicle).
2. Perform DTC confirmation procedure again.

>> GO TO 3.

**6.PERFORM SELF-DIAGNOSIS**

ⓂWith CONSULT

Perform ECM self-diagnosis.

Is DTC "P0139" detected?

YES >> Proceed to [EC-254. "Diagnosis Procedure"](#).

NO >> INSPECTION END

**7.PERFORM COMPONENT FUNCTION CHECK-1**

ⓍWithout CONSULT

1. Start engine and warm it up to normal operating temperature.
2. Turn ignition switch OFF and wait at least 10 seconds.
3. Start engine and keep the engine speed between 3,500 and 4,000 rpm for at least 1 minute under no load.
4. Let engine idle for 1 minute.
5. Check the voltage between ECM harness connector and ground as per the following condition.

ECM			Condition	Voltage
Connector	+	-		
	Terminal			
F51	22	23	Reving up to 4,000 rpm under no load at least 10 times	The voltage should be above 0.73 V at least once during this procedure.

Is the inspection result normal?

- YES >> INSPECTION END
- NO >> GO TO 8.

### 8.PERFORM COMPONENT FUNCTION CHECK-2

Check the voltage between ECM harness connector and ground as per the following condition.

ECM			Condition	Voltage
Connector	+	-		
	Terminal			
F51	22	23	Keeping engine speed at idle for 10 minutes	The voltage should be above 0.73 V at least once during this procedure.

Is the inspection result normal?

- YES >> INSPECTION END
- NO >> GO TO 9.

### 9.PERFORM COMPONENT FUNCTION CHECK-3

Check the voltage between ECM harness connector and ground as per the following condition.

ECM			Condition	Voltage
Connector	+	-		
	Terminal			
F51	22	23	Coasting from 80 km/h (50 MPH) in D position	The voltage should be above 0.73 V at least once during this procedure.

Is the inspection result normal?

- YES >> INSPECTION END
- NO >> Proceed to [EC-241, "Diagnosis Procedure"](#).

## Diagnosis Procedure

INFOID:000000011277992

### 1.CLEAR THE MIXTURE RATIO SELF-LEARNING VALUE

1. Clear the mixture ratio self-learning value. Refer to [EC-146, "Work Procedure"](#).
2. Run engine for at least 10 minutes at idle speed.

Is the 1st trip DTC P0171 or P0172 detected? Is it difficult to start engine?

- YES >> Perform trouble diagnosis for DTC P0171 or P0172. Refer to [EC-263, "DTC Description"](#) or [EC-268, "DTC Description"](#).
- NO >> GO TO 2.

### 2.CHECK HO2S2 GROUND CIRCUIT

1. Turn ignition switch OFF.
2. Disconnect heated oxygen sensor 2 harness connector.
3. Disconnect ECM harness connector.
4. Check the continuity between HO2S2 harness connector and ECM harness connector.

< DTC/CIRCUIT DIAGNOSIS >

+		-		Continuity
HO2S2		ECM		
Connector	Terminal	Connector	Terminal	
F21	1	F51	23	Existed

5. Also check harness for short to power.

Is the inspection result normal?

YES >> GO TO 3.

NO >> Repair or replace error-detected parts.

**3.CHECK HO2S2 INPUT SIGNAL CIRCUIT**

1. Check the continuity between HO2S2 harness connector and ECM harness connector.

+		-		Continuity
HO2S2		ECM		
Connector	Terminal	Connector	Terminal	
F21	2	F51	22	Existed

2. Check the continuity between HO2S2 harness connector and ground, or ECM harness connector and ground.

+		-	Continuity
HO2S2			
Connector	Terminal		
F21	2	Ground	Not existed

+		-	Continuity
ECM			
Connector	Terminal		
F51	22	Ground	Not existed

3. Also check harness for short to power.

Is the inspection result normal?

YES >> GO TO 4.

NO >> Repair or replace error-detected parts.

**4.CHECK HEATED OXYGEN SENSOR 2**

Check the heated oxygen sensor 2. Refer to [EC-256. "Component Inspection"](#).

Is the inspection result normal?

YES >> Check intermittent incident. Refer to [EX-5. "Exploded View"](#).

NO >> GO TO 5.

**5.REPLACE HEATED OXYGEN SENSOR 2**

Replace heated oxygen sensor 2. Refer to [EX-5. "Exploded View"](#).

**CAUTION:**

- Discard any sensor which has been dropped from a height of more than 0.5 m (19.7 in) onto a hard surface such as a concrete floor; use a new one.
- Before installing new sensor, clean exhaust system threads using Oxygen Sensor Thread Cleaner [commercial service tool (J-43897-18 or J43897-12)] and approved Anti-seize Lubricant (commercial service tool).

>> INSPECTION END

A  
EC

C

D

E

F

G

H

I

J

K

L

M

N

O

P

Component Inspection

1.INSPECTION START

Do you have CONSULT?

Do you have CONSULT?

- YES >> GO TO 2.
- NO >> GO TO 3.

2.CHECK HEATED OXYGEN SENSOR 2

Ⓜ With CONSULT

1. Turn ignition switch ON and select "DATA MONITOR" mode of "ENGINE" using CONSULT.
2. Start engine and warm it up to normal operating temperature.
3. Turn ignition switch OFF and wait at least 10 seconds.
4. Start engine and keep the engine speed between 3,500 and 4,000 rpm for at least 1 minute under no load.
5. Let engine idle for 1 minute.
6. Select "FUEL INJECTION" in "ACTIVE TEST" mode of "ENGINE" using CONSULT, and select "HO2S2 (B1)" as the monitor item with CONSULT.
7. Check "HO2S2 (B1)" at idle speed when adjusting "FUEL INJECTION" to ± 25%.

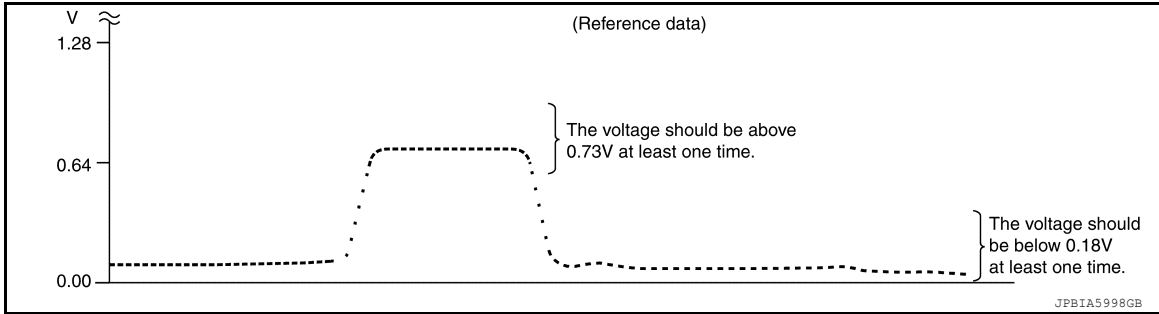

**"HO2S2 (B1)" should be above 0.73 V at least once when the "FUEL INJECTION" is + 25%.**

**"HO2S2 (B1)" should be below 0.18 V at least once when the "FUEL INJECTION" is - 25%.**

Is the inspection result normal?

- YES >> INSPECTION END
- NO >> GO TO 6.

3.CHECK HEATED OXYGEN SENSOR 2-1

ⓧ Without CONSULT

1. Start engine and warm it up to normal operating temperature.
2. Turn ignition switch OFF and wait at least 10 seconds.
3. Start engine and keep the engine speed between 3,500 and 4,000 rpm for at least 1 minute under no load.
4. Let engine idle for 1 minute.
5. Check the voltage between ECM harness connector and ground as per the following condition.

Connector	ECM		Condition	Voltage
	+	-		
	Terminal			
F51	22	23	Revving up to 4,000 rpm under no load at least 10 times	The voltage should be above 0.73 V at least once during this procedure. The voltage should be below 0.18 V at least once during this procedure.

Is the inspection result normal?

- YES >> INSPECTION END
- NO >> GO TO 4.

4.CHECK HEATED OXYGEN SENSOR 2-2

Check the voltage between ECM harness connector and ground as per the following condition.



ECM			Condition	Voltage
Connector	+	-		
	Terminal			
F51	22	23	Keeping engine speed at idle for 10 minutes	The voltage should be above 0.73 V at least once during this procedure. The voltage should be below 0.18 V at least once during this procedure.

A

EC

C

Is the inspection result normal?

YES >> INSPECTION END  
 NO >> GO TO 5.

D

**5. CHECK HEATED OXYGEN SENSOR 2-3**

Check the voltage between ECM harness connector and ground as per the following condition.

E

ECM			Condition	Voltage
Connector	+	-		
	Terminal			
F51	22	23	Coasting from 80 km/h (50 MPH) in D position	The voltage should be above 0.73 V at least once during this procedure. The voltage should be below 0.18 V at least once during this procedure.

F

G

Is the inspection result normal?

YES >> INSPECTION END  
 NO >> GO TO 6.

H

**6. REPLACE HEATED OXYGEN SENSOR 2**

Replace heated oxygen sensor 2. Refer to [EX-5. "Exploded View"](#).

**CAUTION:**

- Discard any sensor which has been dropped from a height of more than 0.5 m (19.7 in) onto a hard surface such as a concrete floor; use a new one.
- Before installing new sensor, clean exhaust system threads using Oxygen Sensor Thread Cleaner [commercial service tool (J-43897-18 or J43897-12)] and approved Anti-seize Lubricant (commercial service tool).

I

J

K

>> INSPECTION END

L

M

N

O

P

# P014C, P014D, P015A, P015B, A/F SENSOR 1

< DTC/CIRCUIT DIAGNOSIS >

[QR25DE]

## P014C, P014D, P015A, P015B, A/F SENSOR 1

### DTC Description

INFOID:000000011277994

### DTC DETECTION LOGIC

To judge malfunctions, this diagnosis measures response time of the A/F signal computed by ECM from the A/F sensor 1 signal. The time is compensated by engine operating (speed and load), fuel feedback control constant, and the A/F sensor 1 temperature index. Judgment is based on whether the compensated time (the A/F signal cycling time index) is inordinately long or not.

DTC No.	CONSULT screen terms (Trouble diagnosis content)	DTC detecting condition
P014C	A/F SENSOR1 (B1) (O2 sensor slow response - rich to lean bank 1 sensor 1)	• The response time of a A/F sensor 1 signal delays more than the specified time computed by ECM.
P014D	A/F SENSOR1 (B1) (O2 sensor slow response - lean to rich bank 1 sensor 1)	
P015A	A/F SENSOR1 (B1) (O2 sensor delayed response - rich to lean bank 1 sensor 1)	
P015B	A/F SENSOR1 (B1) (O2 sensor delayed response - lean to rich bank 1 sensor 1)	

### POSSIBLE CAUSE

- Harness or connectors (The A/F sensor 1 circuit is open or shorted.)
- A/F sensor 1

### FAIL-SAFE

Not applicable

### DTC CONFIRMATION PROCEDURE

#### 1.PRECONDITIONING

If DTC Confirmation Procedure has been previously conducted, always perform the following procedure before conducting the next test.

1. Turn ignition switch OFF and wait at least 10 seconds.
2. Turn ignition switch ON.
3. Turn ignition switch OFF and wait at least 10 seconds.

#### TESTING CONDITION:

**Before performing the following procedure, confirm that battery voltage is more than 11 V at idle.**

Do you have CONSULT?

- YES >> GO TO 2.  
NO >> GO TO 6.

#### 2.PERFORM DTC CONFIRMATION PROCEDURE-1

##### With CONSULT

1. Start engine and warm it up to normal operating temperature.
2. Turn ignition switch OFF and wait at least 10 seconds.
3. Turn ignition switch ON.
4. Turn ignition switch OFF and wait at least 10 seconds.
5. Start engine and keep the engine speed between 3,500 and 4,000 rpm for at least 1 minute under no load.
6. Let engine idle for 1 minute.
7. Increase the engine speed up to about 3,600 rpm and keep it for 10 seconds.
8. Fully release accelerator pedal and then let engine idle for about 1 minute.
9. Check the items status of "DATA MONITOR" as follows.

#### NOTE:

If "PRSN" changed to "ABSNT", refer to [EC-160, "Component Function Check"](#).

# P014C, P014D, P015A, P015B, A/F SENSOR 1

< DTC/CIRCUIT DIAGNOSIS >

[QR25DE]

Data monitor item	Status
A/F SEN1 DIAG3 (B1)	PRSNT

Is "PRSNT" displayed on CONSULT screen?

- YES >> GO TO 4.
- NO >> GO TO 3.

## 3.PERFORM DTC CONFIRMATION PROCEDURE-2

### With CONSULT

Perform DTC confirmation procedure-1 again.

Is "PRSNT" displayed on CONSULT screen?

- YES >> GO TO 4.
- NO >> Refer to [EC-160, "Component Function Check"](#).

## 4.PERFORM DTC CONFIRMATION PROCEDURE-2

### With CONSULT

1. Wait for about 20 seconds at idle.
2. Check the items status of "DATA MONITOR" as follows.

#### NOTE:

If "CMPLT" changed to "INCMPT", refer to [EC-160, "Component Function Check"](#).

Data monitor item	Status
A/F SEN1 DIAG1 (B1)	CMPLT
A/F SEN1 DIAG2 (B1)	

Is "CMPLT" displayed on CONSULT screen?

- YES >> GO TO 5.
- NO >> Refer to [EC-160, "Component Function Check"](#).

## 5.PERFORM SELF-DIAGNOSIS

### With CONSULT

Check the "SELF-DIAG RESULT".

Is any DTC detected?

- YES >> Proceed to [EC-260, "Diagnosis Procedure"](#).
- NO >> INSPECTION END

## 6.CHECK AIR-FUEL RATIO SELF-LEARNING VALUE

### With GST

1. Start engine and warm it up to normal operating temperature.
2. Select Service \$01 with GST.
3. Calculate the total value of "Short term fuel trim" and "Long term fuel trim" indications.

Is the total percentage within  $\pm 15\%$ ?

- YES >> GO TO 8.
- NO >> GO TO 7.

## 7.DETECT MALFUNCTIONING PART

Check the following.

- Intake air leaks
- Exhaust gas leaks
- Incorrect fuel pressure
- Lack of fuel
- Fuel injector
- Incorrect PCV hose connection
- PCV valve
- Mass air flow sensor

# P014C, P014D, P015A, P015B, A/F SENSOR 1

< DTC/CIRCUIT DIAGNOSIS >

[QR25DE]

>> Repair or replace malfunctioning part.

## 8. PERFORM DTC CONFIRMATION PROCEDURE

1. Turn ignition switch OFF and wait at least 10 seconds.
2. Turn ignition switch ON.
3. Turn ignition switch OFF and wait at least 10 seconds.
4. Start engine and keep the engine speed between 3,500 and 4,000 rpm for at least 1 minute under no load.
5. Let engine idle for 1 minute.
6. Increase the engine speed up to about 3,600 rpm and keep it for 10 seconds.
7. Fully release accelerator pedal and then let engine idle for about 1 minute.
8. Check 1st trip DTC.

Is 1st trip DTC detected?

- YES >> Proceed to [EC-260, "Diagnosis Procedure"](#).  
NO >> INSPECTION END

## Diagnosis Procedure

INFOID:0000000011277995

### 1. RETIGHTEN A/F SENSOR 1

Loosen and retighten the A/F sensor 1. Refer to [EM-32, "Exploded View"](#).

>> GO TO 2.

### 2. CHECK EXHAUST GAS LEAK

1. Start engine and run it at idle.
2. Listen for an exhaust gas leak before three way catalyst (manifold).

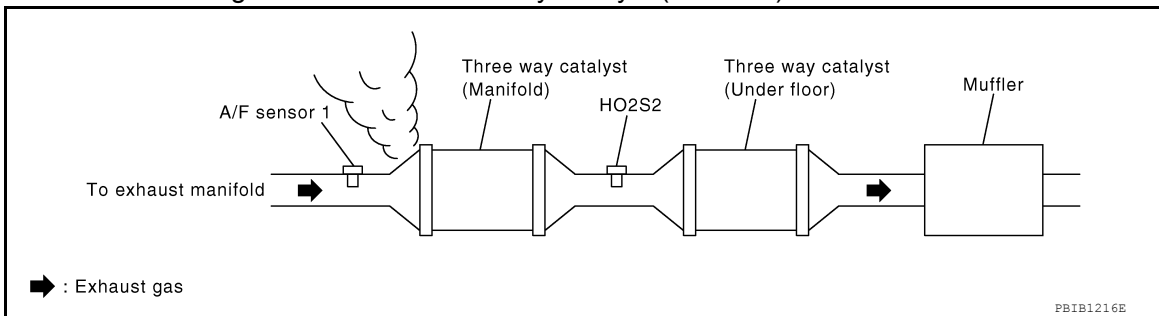

Is exhaust gas leak detected?

- YES >> Repair or replace.  
NO >> GO TO 3.

### 3. CHECK FOR INTAKE AIR LEAK

Listen for an intake air leak after the mass air flow sensor.

Is intake air leak detected?

- YES >> Repair or replace.  
NO >> GO TO 4.

### 4. CLEAR THE MIXTURE RATIO SELF-LEARNING VALUE

1. Clear the mixture ratio self-learning value. Refer to [EC-146, "Work Procedure"](#).
2. Run engine for at least 10 minutes at idle speed.

Is the 1st trip DTC P0171 or P172 detected? Is it difficult to start engine?

- YES >> Perform trouble diagnosis for DTC P0171 or P0172. Refer to [EC-263, "DTC Description"](#) or [EC-268, "DTC Description"](#).  
NO >> GO TO 5.

### 5. CHECK AIR FUEL RATIO (A/F) SENSOR 1 POWER SUPPLY CIRCUIT

1. Disconnect A/F sensor 1 harness connector.
2. Turn ignition switch ON.
3. Check the voltage between A/F sensor 1 harness connector and ground.

# P014C, P014D, P015A, P015B, A/F SENSOR 1

< DTC/CIRCUIT DIAGNOSIS >

[QR25DE]

+		-	Voltage
A/F sensor 1			
Connector	Terminal		
F18	4	Ground	Battery voltage

Is the inspection result normal?

YES >> GO TO 6.

NO >> Repair or replace error-detected parts.

## 6. CHECK A/F SENSOR 1 INPUT SIGNAL CIRCUIT

1. Turn ignition switch OFF.
2. Disconnect ECM harness connector.
3. Check the continuity between A/F sensor 1 harness connector and ECM harness connector.

+		-		Continuity
A/F sensor 1		ECM		
Connector	Terminal	Connector	Terminal	
F18	1	F51	41	Existed
	2		45	

4. Check the continuity between A/F sensor 1 harness connector and ground, or ECM harness connector and ground.

+		-	Continuity
A/F sensor 1			
Connector	Terminal		
F18	1	Ground	Not existed
	2		

+		-	Continuity
ECM			
Connector	Terminal		
F51	41	Ground	Not existed
	45		

5. Also check harness for short to power.

Is the inspection result normal?

YES >> GO TO 7.

NO >> Repair or replace error-detected parts.

## 7. CHECK AIR FUEL RATIO (A/F) SENSOR 1 HEATER

Refer to [EC-189, "Component Inspection"](#).

Is the inspection result normal?

YES >> GO TO 8.

NO >> GO TO 11.

## 8. CHECK MASS AIR FLOW SENSOR

Refer to [EC-203, "Component Inspection"](#).

Is the inspection result normal?

YES >> GO TO 9.

NO >> Replace mass air flow sensor. Refer to [EM-26, "Exploded View"](#).

## 9. CHECK PCV VALVE

## P014C, P014D, P015A, P015B, A/F SENSOR 1

[QR25DE]

< DTC/CIRCUIT DIAGNOSIS >

Refer to [EC-501, "Inspection"](#).

Is the inspection result normal?

YES >> GO TO 10.

NO >> Repair or replace PCV valve. Refer to [EC-14, "Component Parts Location"](#).

### 10. CHECK INTERMITTENT INCIDENT

Perform [GI-44, "Intermittent Incident"](#).

Is the inspection result normal?

YES >> GO TO 11.

NO >> Repair or replace.

### 11. REPLACE AIR FUEL RATIO (A/F) SENSOR 1

Replace air fuel ratio (A/F) sensor 1. Refer to [EM-32, "Exploded View"](#).

#### **CAUTION:**

- Discard any sensor which has been dropped from a height of more than 0.5 m (19.7 in) onto a hard surface such as a concrete floor; use a new one.
- Before installing new sensor, clean exhaust system threads using Oxygen Sensor Thread Cleaner [commercial service tool (J-43897-18 or J43897-12)] and approved Anti-seize Lubricant (commercial service tool).

>> INSPECTION END

# P0171 FUEL INJECTION SYSTEM FUNCTION

< DTC/CIRCUIT DIAGNOSIS >

[QR25DE]

## P0171 FUEL INJECTION SYSTEM FUNCTION

### DTC Description

INFOID:0000000011277996

### DTC DETECTION LOGIC

With the Air/Fuel Mixture Ratio Self-Learning Control, the actual mixture ratio can be brought closely to the theoretical mixture ratio based on the mixture ratio feedback signal from the A/F sensors 1. The ECM calculates the necessary compensation to correct the offset between the actual and the theoretical ratios.

In case the amount of the compensation value is extremely large (The actual mixture ratio is too lean.), the ECM judges the condition as the fuel injection system malfunction and lights up the MIL (2 trip detection logic).

Sensor	Input signal to ECM	ECM function	Actuator
A/F sensor 1	Density of oxygen in exhaust gas (Mixture ratio feedback signal)	Fuel injection control	Fuel injector

DTC No.	CONSULT screen terms (Trouble diagnosis content)	DTC detecting condition
P0171	FUEL SYS-LEAN-B1 (System too lean bank 1)	<ul style="list-style-type: none"><li>Fuel injection system does not operate properly.</li><li>The amount of mixture ratio compensation is too large. (The mixture ratio is too lean.)</li></ul>

### POSSIBLE CAUSE

- Intake air leaks
- A/F sensor 1
- Fuel injector
- Exhaust gas leaks
- Incorrect fuel pressure
- Lack of fuel
- Mass air flow sensor
- Incorrect PCV hose connection

### FAIL-SAFE

Traveling control mode (Accelerator angle variation control)

### DTC CONFIRMATION PROCEDURE

#### 1. PRECONDITIONING

If DTC Confirmation Procedure has been previously conducted, always perform the following procedure before conducting the next test.

1. Turn ignition switch OFF and wait at least 10 seconds.
2. Turn ignition switch ON.
3. Turn ignition switch OFF and wait at least 10 seconds.

>> GO TO 2.

#### 2. PERFORM DTC CONFIRMATION PROCEDURE-1

1. Clear the mixture ratio self-learning value. Refer to [EC-146, "Work Procedure"](#).
2. Start engine.

Is it difficult to start engine?

- YES >> GO TO 3.
- NO >> GO TO 4.

#### 3. RESTART ENGINE

If it is difficult to start engine, the fuel injection system has a malfunction, too.  
Crank engine while depressing accelerator pedal.

#### NOTE:

**When depressing accelerator pedal three-fourths (3/4) or more, the control system does not start the engine. Do not depress accelerator pedal too much.**

Does engine start?

# P0171 FUEL INJECTION SYSTEM FUNCTION

[QR25DE]

< DTC/CIRCUIT DIAGNOSIS >

- YES >> Proceed to [EC-264. "Diagnosis Procedure"](#).  
NO >> Check exhaust and intake air leak visually.

## 4.PERFORM DTC CONFIRMATION PROCEDURE-2

1. Start engine and let it idle for at least 5 minutes.
2. Check 1st trip DTC.

Is 1st trip DTC detected?

- YES >> Proceed to [EC-264. "Diagnosis Procedure"](#).  
NO >> GO TO 5.

## 5.PERFORM DTC CONFIRMATION PROCEDURE-3

1. Turn ignition switch OFF and wait at least 10 seconds.
2. Start engine.
3. Maintain the following conditions for at least 10 consecutive minutes.  
Hold the accelerator pedal as steady as possible.

VHCL SPEED SE	50 - 120 km/h (31 - 75 MPH)
---------------	-----------------------------

### CAUTION:

**Always drive vehicle at a safe speed.**

4. Check 1st trip DTC.

Is 1st trip DTC detected?

- YES >> Proceed to [EC-264. "Diagnosis Procedure"](#).  
NO >> INSPECTION END

## Diagnosis Procedure

INFOID:0000000011277997

### 1.CHECK EXHAUST GAS LEAK

1. Start engine and run it at idle.
2. Listen for an exhaust gas leak before three way catalyst (manifold).

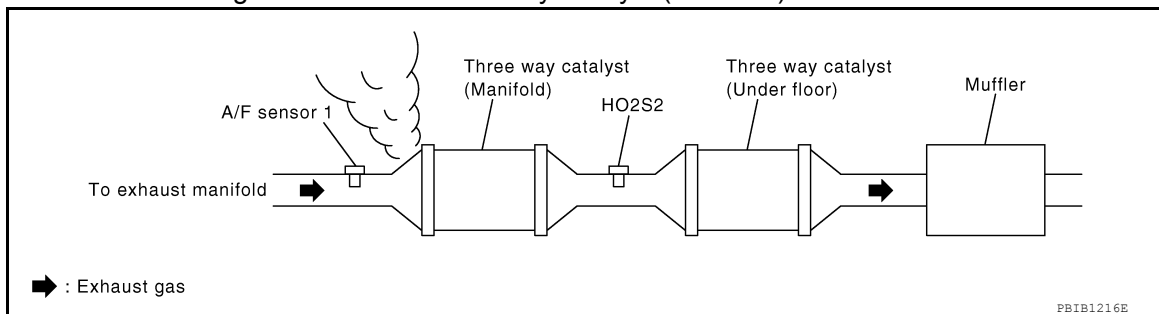

Is exhaust gas leak detected?

- YES >> Repair or replace error-detected parts.  
NO >> GO TO 2.

### 2.CHECK FOR INTAKE AIR LEAK

1. Listen for an intake air leak after the mass air flow sensor.
2. Check PCV hose connection.

Intake air leak detected?

- YES >> Repair or replace error-detected parts.  
NO >> GO TO 3.

### 3.CHECK A/F SENSOR 1 INPUT SIGNAL CIRCUIT

1. Turn ignition switch OFF.
2. Disconnect corresponding A/F sensor 1 harness connector.
3. Disconnect ECM harness connector.
4. Check the continuity between A/F sensor 1 harness connector and ECM harness connector.



# P0171 FUEL INJECTION SYSTEM FUNCTION

< DTC/CIRCUIT DIAGNOSIS >

[QR25DE]

+		-		Continuity
A/F sensor 1		ECM		
Connector	Terminal	Connector	Terminal	
F18	1	F51	41	Existed
	2		45	

5. Check the continuity between A/F sensor 1 harness connector and ground, or ECM harness connector and ground.

+		-	Continuity
A/F sensor 1			
Connector	Terminal		
F18	1	Ground	Not existed
	2		

+		-	Continuity
ECM			
Connector	Terminal		
F51	41	Ground	Not existed
	45		

6. Also check harness for short to power.

Is the inspection result normal?

YES >> GO TO 4.

NO >> Repair or replace error-detected parts.

## 4.CHECK FUEL PRESSURE

Check fuel pressure. Refer to [EC-147, "Work Procedure"](#).

Is the inspection result normal?

YES >> GO TO 6.

NO >> GO TO 5.

## 5. DETECT MALFUNCTIONING PART

Check fuel hoses and fuel tubes for clogging. Refer to [EM-45, "Exploded View"](#).

Is the inspection result normal?

YES >> Replace "fuel filter and fuel pump assembly". Refer to [FL-5, "Removal and Installation"](#).

NO >> Repair or replace error-detected parts.

## 6.CHECK MASS AIR FLOW SENSOR

Ⓜ With CONSULT

1. Install all removed parts.

2. Start engine and warm it up to normal operating temperature.

3. Check "MASS AIR FLOW SENSOR (Hz)" in "DATA MONITOR" mode of "ENGINE" using CONSULT.

Monitor item	Condition	Value
MASS AIR FLOW SENSOR (Hz)	Ignition switch ON (Engine stopped.)	Approx. 3500 Hz
	Idle (Engine is warmed-up to normal operating temperature.)	3500- 4100 Hz
	2,500 rpm (Engine is warmed-up to normal operating temperature.)	5000 - 5600 Hz
	Idle to about 4,000 rpm	3500 - 4100 Hz to Approx. 6300 Hz*

\*: Check for linear frequency rise in response to engine being increased to about 4,000 rpm.

# P0171 FUEL INJECTION SYSTEM FUNCTION

< DTC/CIRCUIT DIAGNOSIS >

[QR25DE]

⊗ Without CONSULT

1. Install all removed parts.
2. Start engine and warm it up to normal operating temperature.
3. Check mass air flow sensor signal in Service \$01 with GST.

ECM			Condition	Value
Connector	+	-		
	Terminal			
F51	35	34	Ignition switch ON (Engine stopped.)	Approx. 3500 Hz
			Idle (Engine is warmed-up to normal operating temperature.)	3500- 4100 Hz
			2,500 rpm (Engine is warmed-up to normal operating temperature.)	5000 - 5600 Hz
			Idle to about 4,000 rpm	3500 - 4100 Hz to Approx. 6300 Hz*
			Ignition switch ON (Engine stopped.)	Approx. 3500 Hz

\*: Check for linear frequency rise in response to engine being increased to about 4,000 rpm.

Is the measurement value within the specification?

YES >> GO TO 7.

NO >> Check connectors for rusted terminals or loose connections in the mass air flow sensor circuit or grounds. Refer to [EC-205, "DTC Description"](#).

## 7. CHECK FUNCTION OF FUEL INJECTOR

Ⓟ With CONSULT

1. Start engine.
2. Perform "POWER BALANCE" in "ACTIVE TEST" mode of "ENGINE" using CONSULT.
3. Make sure that each circuit produces a momentary engine speed drop.

⊗ Without CONSULT

1. Let engine idle.
2. Listen to each fuel injector operating sound.

**Clicking noise should be heard.**

Is the inspection result normal?

YES >> GO TO 8.

NO >> Perform trouble diagnosis for "FUEL INJECTOR", refer to [EC-467, "Component Function Check"](#).

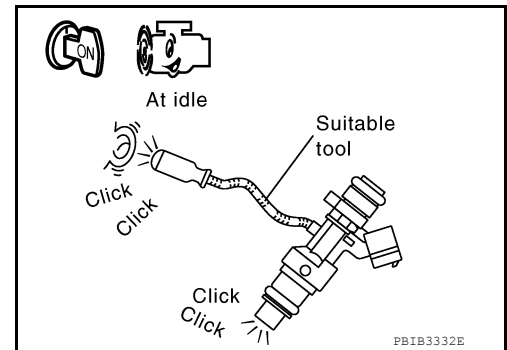

## 8. CHECK FUEL INJECTOR

1. Turn ignition switch OFF.
2. Confirm that the engine is cooled down and there are no fire hazards near the vehicle.
3. Disconnect all fuel injector harness connectors.
4. Remove fuel tube assembly. Refer to [EM-45, "Removal and Installation"](#).  
Keep fuel hose and all fuel injectors connected to fuel tube.
5. Disconnect all ignition coil harness connectors.
6. Prepare pans or saucers under each fuel injector.

# P0171 FUEL INJECTION SYSTEM FUNCTION

< DTC/CIRCUIT DIAGNOSIS >

[QR25DE]

7. Crank engine for about 3 seconds.

**Fuel should be sprayed evenly for each fuel injector.**

Is the inspection result normal?

YES >> GO TO 9.

NO >> Replace fuel injectors from which fuel does not spray out. Always replace O-ring with new ones. Refer to [EM-45, "Removal and Installation"](#).

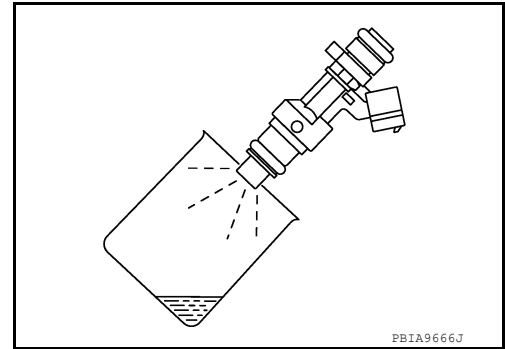

## 9. CHECK INTERMITTENT INCIDENT

Refer to [GI-44, "Intermittent Incident"](#).

>> INSPECTION END

A

EC

C

D

E

F

G

H

I

J

K

L

M

N

O

P

# P0172 FUEL INJECTION SYSTEM FUNCTION

< DTC/CIRCUIT DIAGNOSIS >

[QR25DE]

## P0172 FUEL INJECTION SYSTEM FUNCTION

### DTC Description

INFOID:000000011277998

### DTC DETECTION LOGIC

With the Air/Fuel Mixture Ratio Self-Learning Control, the actual mixture ratio can be brought closely to the theoretical mixture ratio based on the mixture ratio feedback signal from the A/F sensors 1. The ECM calculates the necessary compensation to correct the offset between the actual and the theoretical ratios.

In case the amount of the compensation value is extremely large (The actual mixture ratio is too rich.), the ECM judges the condition as the fuel injection system malfunction and lights up the MIL (2 trip detection logic).

Sensor	Input signal to ECM	ECM function	Actuator
A/F sensor 1	Density of oxygen in exhaust gas (Mixture ratio feedback signal)	Fuel injection control	Fuel injector

DTC No.	CONSULT screen terms (Trouble diagnosis content)	DTC detecting condition
P0172	FUEL SYS-RICH-B1 (System too rich bank 1)	<ul style="list-style-type: none"><li>Fuel injection system does not operate properly.</li><li>The amount of mixture ratio compensation is too large. (The mixture ratio is too rich.)</li></ul>

### POSSIBLE CAUSE

- A/F sensor 1
- Fuel injector
- Exhaust gas leaks
- Incorrect fuel pressure
- Mass air flow sensor

### FAIL-SAFE

Traveling control mode (Accelerator angle variation control)

### DTC CONFIRMATION PROCEDURE

#### 1. PRECONDITIONING

If DTC Confirmation Procedure has been previously conducted, always perform the following procedure before conducting the next test.

1. Turn ignition switch OFF and wait at least 10 seconds.
2. Turn ignition switch ON.
3. Turn ignition switch OFF and wait at least 10 seconds.

>> GO TO 2.

#### 2. PERFORM DTC CONFIRMATION PROCEDURE-1

1. Clear the mixture ratio self-learning value. Refer to [EC-146, "Work Procedure"](#).
2. Start engine.

Is it difficult to start engine?

- YES >> GO TO 3.  
NO >> GO TO 4.

#### 3. RESTART ENGINE

If it is difficult to start engine, the fuel injection system has a malfunction, too.

Crank engine while depressing accelerator pedal.

#### NOTE:

**When depressing accelerator pedal three-fourths (3/4) or more, the control system does not start the engine. Do not depress accelerator pedal too much.**

Does engine start?

- YES >> Proceed to [EC-269, "Diagnosis Procedure"](#).  
NO >> Check exhaust and intake air leak visually.

# P0172 FUEL INJECTION SYSTEM FUNCTION

< DTC/CIRCUIT DIAGNOSIS >

[QR25DE]

## 4.PERFORM DTC CONFIRMATION PROCEDURE-2

1. Start engine and let it idle for at least 5 minutes.
2. Check 1st trip DTC.

Is 1st trip DTC detected?

- YES >> Proceed to [EC-269, "Diagnosis Procedure"](#).  
NO >> GO TO 5.

## 5.PERFORM DTC CONFIRMATION PROCEDURE-3

1. Turn ignition switch OFF and wait at least 10 seconds.
2. Start engine.
3. Maintain the following conditions for at least 10 consecutive minutes.  
Hold the accelerator pedal as steady as possible.

VHCL SPEED SE	50 - 120 km/h (31 - 75 MPH)
---------------	-----------------------------

### CAUTION:

**Always drive vehicle at a safe speed.**

4. Check 1st trip DTC.

Is 1st trip DTC detected?

- YES >> Proceed to [EC-269, "Diagnosis Procedure"](#).  
NO >> INSPECTION END

## Diagnosis Procedure

INFOID:000000011277999

### 1.CHECK EXHAUST GAS LEAK

1. Start engine and run it at idle.
2. Listen for an exhaust gas leak before three way catalyst (manifold).

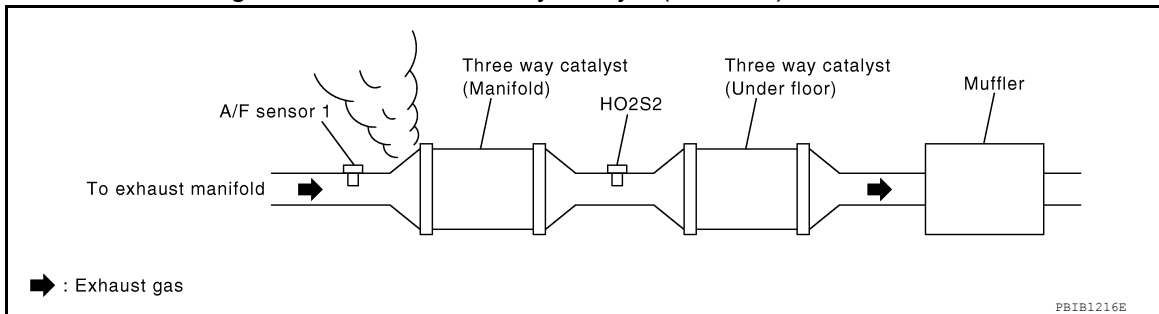

Is exhaust gas leak detected?

- YES >> Repair or replace error-detected parts.  
NO >> GO TO 2.

### 2.CHECK FOR INTAKE AIR LEAK

1. Listen for an intake air leak after the mass air flow sensor.
2. Check PCV hose connection.

Intake air leak detected?

- YES >> Repair or replace error-detected parts.  
NO >> GO TO 3.

### 3.CHECK A/F SENSOR 1 INPUT SIGNAL CIRCUIT

1. Turn ignition switch OFF.
2. Disconnect corresponding A/F sensor 1 harness connector.
3. Disconnect ECM harness connector.
4. Check the continuity between A/F sensor 1 harness connector and ECM harness connector.

# P0172 FUEL INJECTION SYSTEM FUNCTION

[QR25DE]

< DTC/CIRCUIT DIAGNOSIS >

+		-		Continuity
A/F sensor 1		ECM		
Connector	Terminal	Connector	Terminal	
F18	1	F51	41	Existed
	2		45	

5. Check the continuity between A/F sensor 1 harness connector and ground, or ECM harness connector and ground.

+		-	Continuity
A/F sensor 1			
Connector	Terminal		
F18	1	Ground	Not existed
	2		

+		-	Continuity
ECM			
Connector	Terminal		
F51	41	Ground	Not existed
	45		

6. Also check harness for short to power.

Is the inspection result normal?

YES >> GO TO 4.

NO >> Repair or replace error-detected parts.

## 4.CHECK FUEL PRESSURE

Check fuel pressure. Refer to [EC-147, "Work Procedure"](#).

Is the inspection result normal?

YES >> GO TO 6.

NO >> GO TO 5.

## 5. DETECT MALFUNCTIONING PART

Check fuel hoses and fuel tubes for clogging. Refer to [EM-45, "Exploded View"](#).

Is the inspection result normal?

YES >> Replace "fuel filter and fuel pump assembly". Refer to [FL-5, "Removal and Installation"](#).

NO >> Repair or replace error-detected parts.

## 6.CHECK MASS AIR FLOW SENSOR

Ⓜ With CONSULT

1. Install all removed parts.

2. Start engine and warm it up to normal operating temperature.

3. Check "MASS AIR FLOW SENSOR (Hz)" in "DATA MONITOR" mode of "ENGINE" using CONSULT.

Monitor item	Condition	Value
MASS AIR FLOW SENSOR (Hz)	Ignition switch ON (Engine stopped.)	Approx. 3500 Hz
	Idle (Engine is warmed-up to normal operating temperature.)	3500- 4100 Hz
	2,500 rpm (Engine is warmed-up to normal operating temperature.)	5000k - 5600 Hz
	Idle to about 4,000 rpm	3500 - 4100 Hz to Approx. 6300 Hz*

\*: Check for linear frequency rise in response to engine being increased to about 4,000 rpm.

# P0172 FUEL INJECTION SYSTEM FUNCTION

< DTC/CIRCUIT DIAGNOSIS >

[QR25DE]

⊗ Without CONSULT

1. Install all removed parts.
2. Start engine and warm it up to normal operating temperature.
3. Check mass air flow sensor signal in Service \$01 with GST.

ECM			Condition	Value
Connector	+	-		
	Terminal			
F51	35	34	Ignition switch ON (Engine stopped.)	Approx. 3500 Hz
			Idle (Engine is warmed-up to normal operating temperature.)	3500- 4100 Hz
			2,500 rpm (Engine is warmed-up to normal operating temperature.)	5000k - 5600 Hz
			Idle to about 4,000 rpm	3500 - 4100 Hz to Approx. 6300 Hz*
			Ignition switch ON (Engine stopped.)	Approx. 3500 Hz

\*: Check for linear frequency rise in response to engine being increased to about 4,000 rpm.

Is the measurement value within the specification?

YES >> GO TO 7.

NO >> Check connectors for rusted terminals or loose connections in the mass air flow sensor circuit or grounds. Refer to [EC-201, "DTC Description"](#).

## 7. CHECK FUNCTION OF FUEL INJECTOR

Ⓜ With CONSULT

1. Start engine.
2. Perform "POWER BALANCE" in "ACTIVE TEST" mode of "ENGINE" using CONSULT.
3. Make sure that each circuit produces a momentary engine speed drop.

⊗ Without CONSULT

1. Let engine idle.
2. Listen to each fuel injector operating sound.

**Clicking noise should be heard.**

Is the inspection result normal?

YES >> GO TO 8.

NO >> Perform trouble diagnosis for "FUEL INJECTOR", refer to [EC-467, "Component Function Check"](#).

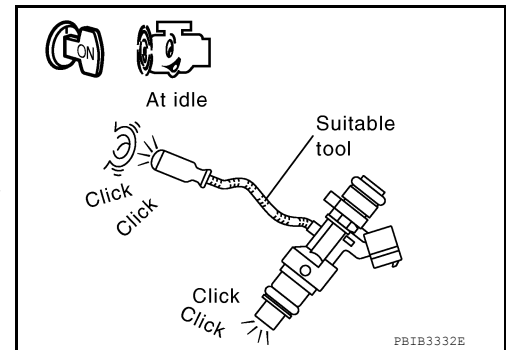

## 8. CHECK FUEL INJECTOR

1. Turn ignition switch OFF.
2. Confirm that the engine is cooled down and there are no fire hazards near the vehicle.
3. Disconnect all fuel injector harness connectors.
4. Remove fuel tube assembly. Refer to [EM-45, "Removal and Installation"](#).  
Keep fuel hose and all fuel injectors connected to fuel tube.
5. Disconnect all ignition coil harness connectors.
6. Prepare pans or saucers under each fuel injector.

## P0172 FUEL INJECTION SYSTEM FUNCTION

< DTC/CIRCUIT DIAGNOSIS >

[QR25DE]

7. Crank engine for about 3 seconds.

**Fuel should be sprayed evenly for each fuel injector.**

Is the inspection result normal?

YES >> GO TO 9.

NO >> Replace fuel injectors from which fuel does not spray out. Always replace O-ring with new ones. Refer to [EM-45, "Removal and Installation"](#).

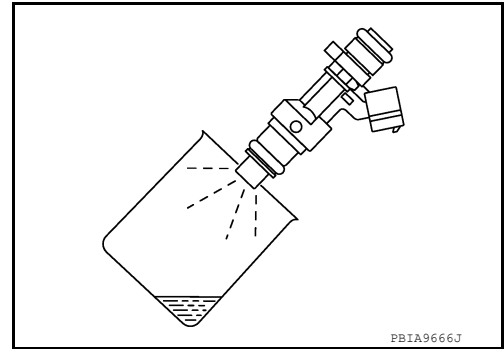

### 9. CHECK INTERMITTENT INCIDENT

Refer to [GI-44, "Intermittent Incident"](#).

>> INSPECTION END



# P0181 FTT SENSOR

< DTC/CIRCUIT DIAGNOSIS >

[QR25DE]

## P0181 FTT SENSOR

### DTC Description

INFOID:000000011278000

### DTC DETECTION LOGIC

DTC No.	CONSULT screen terms (Trouble diagnosis content)	DTC detecting condition	
P0181	FTT SENSOR (Fuel temperature sensor "A" circuit range/ performance)	A	Rationally incorrect voltage from the sensor is sent to ECM, compared with the voltage signals from ECT sensor and intake air temperature sensor.
		B	The comparison result of signals transmitted to ECM from each temperature sensor (IAT sensor, ECT sensor, EOT sensor, and FTT sensor) shows that the voltage signal of the FTT sensor is higher/lower than that of other temperature sensors when the engine is started with its cold state.

### POSSIBLE CAUSE

#### DTC P0181 - A

- Harness or connectors (FTT sensor circuit is open or shorted.)
- FTT sensor
- Combination meter

#### DTC P0181 - B

- Harness or connectors (High or low resistance in the FTT sensor circuit)
- FTT sensor

### FAIL-SAFE

Not applicable

### DTC CONFIRMATION PROCEDURE

#### 1.INSPECTION START

##### Is it necessary to erase permanent DTC?

- YES >> GO TO 7.  
NO >> GO TO 2.

#### 2.PRECONDITIONING

If DTC CONFIRMATION PROCEDURE has been previously conducted, always perform the following procedure before conducting the next test.

1. Turn ignition switch OFF and wait at least 10 seconds.
2. Turn ignition switch ON.
3. Turn ignition switch OFF and wait at least 10 seconds.

>> GO TO 3.

#### 3.PERFORM DTC CONFIRMATION PROCEDURE FOR MALFUNCTION A-1

1. Turn ignition switch ON and wait at least 10 seconds.
2. Check 1st trip DTC.

##### Is 1st trip DTC detected?

- YES >> Proceed to [EC-275, "Diagnosis Procedure"](#).  
NO >> GO TO 4.

#### 4.CHECK ENGINE COOLANT TEMPERATURE

##### With CONSULT

1. Select "COOLAN TEMP/S" in "DATA MONITOR" of "ENGINE" using CONSULT.
2. Check "COOLAN TEMP/S" value.

##### With GST

# P0181 FTT SENSOR

[QR25DE]

## < DTC/CIRCUIT DIAGNOSIS >

Follow the procedure "With CONSULT" above.

"COOLAN TEMP/S" less than 60°C (140°F)?

- YES >> INSPECTION END
- NO >> GO TO 5.

## 5.PERFORM DTC CONFIRMATION PROCEDURE FOR MALFUNCTION A-2

 With CONSULT

1. Cool engine down until "COOLAN TEMP/S" is less than 60°C (140°F).
2. Wait at least 10 seconds.
3. Check 1st trip DTC.

 With GST

Follow the procedure "With CONSULT" above.

Is 1st trip DTC detected?

- YES >> Proceed to [EC-275, "Diagnosis Procedure"](#).
- NO >> GO TO 6.

## 6.CHECK FUEL TANK TEMPERATURE (FTT) SENSOR

1. Turn ignition switch OFF.
2. Disconnect fuel level sensor unit and fuel pump harness connector.
3. Remove fuel level sensor unit. Refer to [FL-5, "Removal and Installation"](#).
4. Check resistance between fuel level sensor unit and fuel pump terminals by heating with hot water as shown in the figure.

Fuel level sensor unit and fuel pump		Condition	Resistance (kΩ)
+	-		
Terminal			
3	1	Temperature [°C (°F)]	20 (68)
			50 (122)

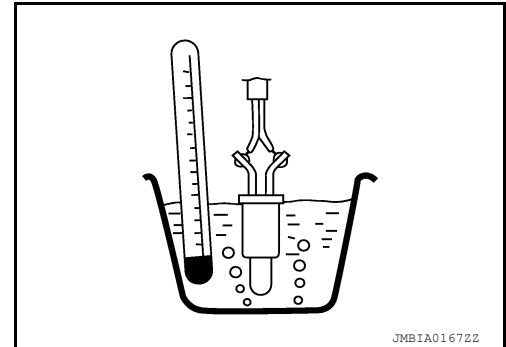

Is the inspection result normal?

- YES >> GO TO 9.
- NO >> Proceed to [EC-275, "Diagnosis Procedure"](#).

## 7.PRECONDITIONING

If DTC CONFIRMATION PROCEDURE has been previously conducted, always perform the following procedure before conducting the next test.

1. Turn ignition switch OFF and wait at least 10 seconds.
2. Turn ignition switch ON.
3. Turn ignition switch OFF and wait at least 10 seconds.

**TESTING CONDITION:**

- Before performing the following procedure, do not add fuel.
- Before performing the following procedure, check that fuel level is between 1/4 and 4/4.
- Before performing the following procedure, confirm that battery voltage is 11 V or more at idle.

>> GO TO 8.

## 8.PERFORM DTC CONFIRMATION PROCEDURE B

1. Move the vehicle to a cool place.

**NOTE:**

Cool the vehicle in an environment of ambient air temperature between -10°C (14°F) and 35°C (95°F).

2. Turn ignition switch OFF and leave the vehicle for 12 hours.

**CAUTION:**

**Never turn ignition switch ON during this procedure.**

**NOTE:**

The vehicle must be cooled with the hood open.

3. Start engine and let it idle for 5 minutes or more.

**CAUTION:**

# P0181 FTT SENSOR

< DTC/CIRCUIT DIAGNOSIS >

[QR25DE]

**Never turn ignition switch OFF during idling.**

4. Check 1st trip DTC.

Is 1st trip DTC detected?

- YES >> Proceed to [EC-275, "Diagnosis Procedure"](#).  
NO >> INSPECTION END

## 9.CHECK INTERMITTENT INCIDENT

Refer to [GI-44, "Intermittent Incident"](#).

>> INSPECTION END

## Diagnosis Procedure

INFOID:000000011278001

### 1.INSPECTION START

Confirm the detected malfunction (A or B). Refer to [EC-273, "DTC Description"](#).

Which malfunction is detected?

- A >> GO TO 2.  
B >> GO TO 6.

### 2.CHECK DTC WITH COMBINATION METER

Check DTC with combination meter. Refer to [MWI-21, "CONSULT Function \(METER/M&A\)"](#).

Is the inspection result normal?

- YES >> GO TO 3.  
NO >> Proceed to [MWI-63, "Component Function Check"](#).

### 3.CHECK FUEL TANK TEMPERATURE (FTT) SENSOR POWER

1. Turn ignition switch OFF.
2. Disconnect fuel level sensor unit and fuel pump harness connector.
3. Turn ignition switch ON.
4. Check the voltage between fuel level sensor unit and fuel pump harness connector and ground.

+		-	Voltage (Approx.)
Connector	Terminal		
B103	3	Ground	5 V

Is the inspection result normal?

- YES >> GO TO 5.  
NO >> GO TO 4.

### 4.CHECK FUEL TANK TEMPERATURE (FTT) SENSOR POWER SUPPLY CIRCUIT

1. Turn ignition switch OFF.
2. Disconnect ECM harness connector.
3. Check the continuity between fuel level sensor unit and fuel pump harness connector and ECM harness connector.

+		-		Continuity
Connector	Terminal	Connector	Terminal	
B103	3	E16	125	Existed

4. Also check harness for short to ground and to power.

Is the inspection result normal?

- YES >> Perform the trouble diagnosis for power supply circuit.  
NO >> Repair or replace error-detected parts.

# P0181 FTT SENSOR

[QR25DE]

< DTC/CIRCUIT DIAGNOSIS >

## 5. CHECK FTT SENSOR GROUND CIRCUIT

1. Turn ignition switch OFF.
2. Disconnect ECM harness connector.
3. Check the continuity between fuel level sensor unit and fuel pump harness connector and ECM harness connector.

+		-		Continuity
Fuel level sensor unit and fuel pump		ECM		
Connector	Terminal	Connector	Terminal	
B103	1	E16	124	Existed

4. Also check harness for short to power.

Is the inspection result normal?

- YES >> GO TO 6.  
 NO >> Repair or replace error-detected parts.

## 6. CHECK FUEL TANK TEMPERATURE (FTT) SENSOR

Check the FTT sensor. Refer to [EC-276, "Component Inspection"](#).

Is the inspection result normal?

- YES >> Check intermittent incident. Refer to [GI-44, "Intermittent Incident"](#).  
 NO >> Replace fuel level sensor unit and fuel pump. Refer to [FL-5, "Removal and Installation"](#).

### Component Inspection

INFOID:000000011278002

## 1. CHECK FUEL TANK TEMPERATURE (FTT) SENSOR

1. Turn ignition switch OFF.
2. Disconnect fuel level sensor unit and fuel pump harness connector.
3. Remove fuel level sensor unit. Refer to [FL-5, "Removal and Installation"](#).
4. Check resistance between fuel level sensor unit and fuel pump terminals by heating with hot water as shown in the figure.

Fuel level sensor unit and fuel pump		Condition	Resistance (kΩ)
+	-		
Terminal			
3	1	Temperature [°C (°F)]	20 (68)
			50 (122)
			2.3 – 2.7
			0.79 – 0.90

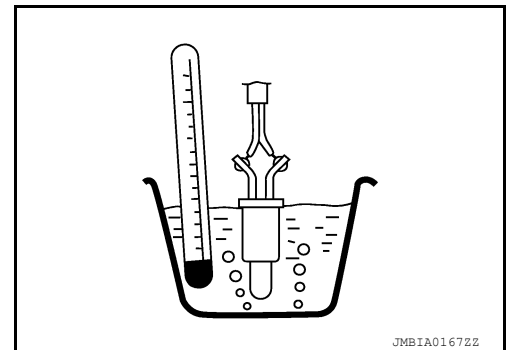

Is the inspection result normal?

- YES >> INSPECTION END  
 NO >> Replace fuel level sensor unit and fuel pump. Refer to [FL-5, "Removal and Installation"](#).

# P0182, P0183 FTT SENSOR

< DTC/CIRCUIT DIAGNOSIS >

[QR25DE]

## P0182, P0183 FTT SENSOR

### DTC Description

INFOID:000000011278003

### DTC DETECTION LOGIC

DTC No.	CONSULT screen terms (Trouble diagnosis content)	DTC detecting condition
P0182	FTT SEN/CIRCUIT (Fuel temperature sensor "A" circuit low)	An excessively low voltage from the sensor is sent to ECM.
P0183	FTT SEN/CIRCUIT (Fuel temperature sensor "A" circuit high)	An excessively high voltage from the sensor is sent to ECM.

### POSSIBLE CAUSE

- Harness or connectors (The FTT sensor circuit is open or shorted.)
- Fuel tank temperature sensor
- Combination meter

### FAIL-SAFE

Not applicable

### DTC CONFIRMATION PROCEDURE

#### 1. PRECONDITIONING

If DTC Confirmation Procedure has been previously conducted, always perform the following procedure before conducting the next test.

1. Turn ignition switch OFF and wait at least 10 seconds.
2. Turn ignition switch ON.
3. Turn ignition switch OFF and wait at least 10 seconds.

>> GO TO 2.

#### 2. PERFORM DTC CONFIRMATION PROCEDURE

1. Turn ignition switch ON and wait at least 5 seconds.
2. Check 1st trip DTC.

Is 1st trip DTC detected?

- YES >> Proceed to [EC-277, "Diagnosis Procedure"](#).
- NO >> INSPECTION END

### Diagnosis Procedure

INFOID:000000011278004

#### 1. CHECK DTC WITH COMBINATION METER

Refer to [MWI-21, "CONSULT Function \(METER/M&A\)"](#).

Is the inspection result normal?

- YES >> GO TO 2.
- NO >> Proceed to [MWI-63, "Component Function Check"](#).

#### 2. CHECK FUEL TANK TEMPERATURE (FTT) SENSOR POWER SUPPLY

1. Turn ignition switch OFF.
2. Disconnect fuel level sensor unit and fuel pump harness connector.
3. Turn ignition switch ON.
4. Check the voltage between fuel level sensor unit and fuel pump harness connector and ground.

# P0182, P0183 FTT SENSOR

[QR25DE]

< DTC/CIRCUIT DIAGNOSIS >

+		-	Voltage (Approx.)
Fuel level sensor unit and fuel pump			
Connector	Terminal		
B103	3	Ground	5 V

Is the inspection result normal?

YES >> GO TO 4.

NO >> GO TO 3.

## 3. CHECK FUEL TANK TEMPERATURE (FTT) SENSOR POWER SUPPLY CIRCUIT

1. Turn ignition switch OFF.
2. Disconnect ECM harness connector.
3. Check the continuity between fuel level sensor unit and fuel pump harness connector and ECM harness connector.

+		-		Continuity
Fuel level sensor unit and fuel pump		ECM		
Connector	Terminal	Connector	Terminal	
B103	3	E16	125	Existed

4. Also check harness for short to ground and to power.

Is the inspection result normal?

YES >> Perform the trouble diagnosis for power supply circuit.

NO >> Repair or replace error-detected parts.

## 4. CHECK FUEL TANK TEMPERATURE (FTT) SENSOR GROUND CIRCUIT

1. Turn ignition switch OFF.
2. Disconnect ECM connector.
3. Check the continuity between fuel level sensor unit and fuel pump harness connector and ECM harness connector.

+		-		Continuity
Fuel level sensor unit and fuel pump		ECM		
Connector	Terminal	Connector	Terminal	
B103	1	E16	124	Existed

4. Also check harness for short to power.

Is the inspection result normal?

YES >> GO TO 5.

NO >> Repair or replace error-detected parts.

## 5. CHECK FUEL TANK TEMPERATURE (FTT) SENSOR

Check the FTT sensor. Refer to [EC-279, "Component Inspection"](#).

Is the inspection result normal?

YES >> GO TO 6.

NO >> Replace "fuel level sensor unit and fuel pump". Refer to [FL-5, "Removal and Installation"](#).

## 6. CHECK INTERMITTENT INCIDENT

Refer to [GI-44, "Intermittent Incident"](#).

>> INSPECTION END

# P0182, P0183 FTT SENSOR

< DTC/CIRCUIT DIAGNOSIS >

[QR25DE]

## Component Inspection

INFOID:000000011278005

### 1. CHECK FUEL TANK TEMPERATURE (FTT) SENSOR

1. Turn ignition switch OFF.
2. Disconnect fuel level sensor unit and fuel pump harness connector.
3. Remove fuel level sensor unit. Refer to [FL-5. "Removal and Installation"](#).
4. Check resistance between fuel level sensor unit and fuel pump terminals by heating with hot water as shown in the figure.

Fuel level sensor unit and fuel pump		Condition	Resistance (kΩ)
+	-		
Terminal			
3	1	Temperature [°C (°F)]	
		20 (68)	2.3 – 2.7
		50 (122)	0.79 – 0.90

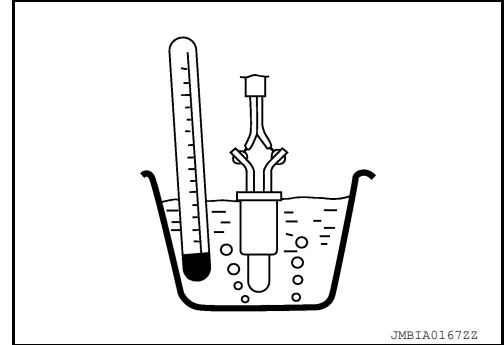

Is the inspection result normal?

YES >> INSPECTION END

NO >> Replace fuel level sensor unit and fuel pump. Refer to [FL-5. "Removal and Installation"](#).

A  
EC  
C  
D  
E  
F  
G  
H  
I  
J  
K  
L  
M  
N  
O  
P

# P0196 EOT SENSOR

[QR25DE]

< DTC/CIRCUIT DIAGNOSIS >

## P0196 EOT SENSOR

### DTC Description

INFOID:000000011278006

### DTC DETECTION LOGIC

DTC No.	CONSULT screen terms (Trouble diagnosis content)	DTC detecting condition	
P0196	EOT SENSOR (Engine oil temperature sensor range/performance)	A	Rationally incorrect voltage from the sensor is sent to ECM, compared with the voltage signals from EOT sensor and intake air temperature sensor.
		B	The comparison result of signals transmitted to ECM from each temperature sensor (IAT sensor, ECT sensor, FTT sensor, and EOT sensor) shows that the signal voltage of the EOT sensor is higher/lower than that of other temperature sensors when the engine is started with its cold state.

### POSSIBLE CAUSE

DTC P0196 - A

- Harness or connectors (EOT sensor circuit is open or shorted.)
- EOT sensor

DTC P0196 - B

- Harness or connectors (High or low resistance in the EOT sensor circuit)
- EOT sensor

### FAIL-SAFE

Not applicable

### DTC CONFIRMATION PROCEDURE

#### 1. CHECK DTC PRIORITY

If DTC P0196 is displayed with DTC P0197 or P0198, first perform the trouble diagnosis for DTC P0197 or P0198.

#### Is applicable DTC detected?

- YES >> Perform diagnosis of applicable. Refer to [EC-96, "DTC Index"](#).  
NO >> GO TO 2.

#### 2. INSPECTION START

#### Is it necessary to erase permanent DTC?

- YES >> GO TO 7.  
NO >> GO TO 3.

#### 3. PRECONDITIONING

If DTC CONFIRMATION PROCEDURE has been previously conducted, always perform the following procedure before conducting the next test.

1. Turn ignition switch OFF and wait at least 10 seconds.
2. Turn ignition switch ON.
3. Turn ignition switch OFF and wait at least 10 seconds.

#### **TESTING CONDITION:**

**Before performing the following procedure, confirm that battery voltage is 11 V or more at idle.**

>> GO TO 4.

#### 4. PERFORM DTC CONFIRMATION PROCEDURE FOR MALFUNCTION A-1

1. Start engine and warm it up to normal operating temperature.
2. Turn ignition switch OFF and wait at least 10 seconds.
3. Turn ignition switch ON.



# P0196 EOT SENSOR

[QR25DE]

## < DTC/CIRCUIT DIAGNOSIS >

4. Turn ignition switch OFF and wait at least 10 seconds.
5. Start engine and let it idle for 5 minutes and 10 seconds.
6. Check 1st trip DTC.

### Is 1st trip DTC detected?

- YES >> Proceed to [EC-282, "Diagnosis Procedure"](#).  
 NO >> GO TO 5.

## 5.PERFORM DTC CONFIRMATION PROCEDURE FOR MALFUNCTION A-2

### ⓂWith CONSULT

1. Select "DATA MONITOR" mode of "ENGINE" using CONSULT.
2. Check that "COOLAN TEMP/S" indicates above 80°C (176°F).  
 If it is above 80°C (176°F), go to the following steps.  
 If it is below 80°C (176°F), warm engine up until "COOLAN TEMP/S" indicates more than 80°C (176°F).  
 Then perform the following steps.
3. Turn ignition switch OFF and soak the vehicle in a cool place.
4. Turn ignition switch ON.  
**NOTE:**  
**Do not turn ignition switch OFF until step 8.**
5. Select "DATA MONITOR" mode of "ENGINE" using CONSULT.
6. Check the following.

COOLAN TEMP/S	Below 40°C (104°F)
INT/A TEMP SE	Below 40°C (104°F)
Difference between "COOLAN TEMP/S" and "INT/A TEMP SE"	Within 6°C (11°F)

If they are within the specified range, perform the following steps.  
 If they are out of the specified range, soak the vehicle to meet the above conditions. Then perform the following steps.

### NOTE:

- Do not turn ignition switch OFF.
- If it is supposed to need a long period of time, do not deplete the battery.

7. Start engine and let it idle for 5 minutes.
8. Check 1st trip DTC.

### ⓂWith GST

Follow the procedure "With CONSULT" above.

### Is 1st trip DTC detected?

- YES >> Proceed to [EC-282, "Diagnosis Procedure"](#).  
 NO >> GO TO 6.

## 6.CHECK ENGINE OIL TEMPERATURE (EOT) SENSOR

1. Turn ignition switch OFF.
2. Disconnect EOT sensor harness connector.
3. Remove EOT sensor. Refer to [EC-14, "Component Parts Location"](#).
4. Check resistance between EOT sensor terminals by heating with hot water as shown in the figure.

EOT sensor		Condition	Resistance (kΩ)
+	-		
Terminal			
1	2	Temperature [°C (°F)]	
		20 (68)	2.37 – 2.63
		50 (122)	0.68 – 1.00
		90 (194)	0.236 – 0.260

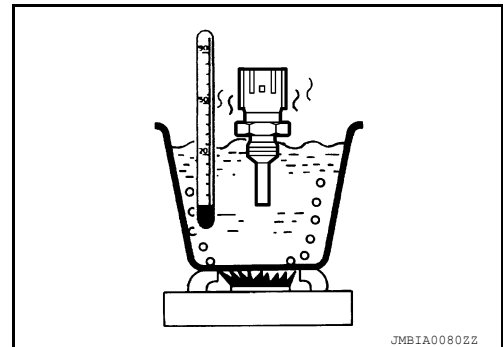

### Is the inspection result normal?

- YES >> GO TO 9.  
 NO >> Proceed to [EC-282, "Diagnosis Procedure"](#).

## 7.PRECONDITIONING

# P0196 EOT SENSOR

[QR25DE]

< DTC/CIRCUIT DIAGNOSIS >

If DTC CONFIRMATION PROCEDURE has been previously conducted, always perform the following procedure before conducting the next test.

1. Turn ignition switch OFF and wait at least 10 seconds.
2. Turn ignition switch ON.
3. Turn ignition switch OFF and wait at least 10 seconds.

## TESTING CONDITION:

- Before performing the following procedure, do not add fuel.
- Before performing the following procedure, check that fuel level is between 1/4 and 4/4.
- Before performing the following procedure, confirm that battery voltage is 11 V or more at idle.

>> GO TO 8.

## 8. PERFORM DTC CONFIRMATION PROCEDURE B

1. Move the vehicle to a cool place.

### NOTE:

Cool the vehicle in an environment of ambient air temperature between -10°C (14°F) and 35°C (95°F).

2. Turn ignition switch OFF and leave the vehicle for 12 hours.

### CAUTION:

Never turn ignition switch ON during this procedure.

### NOTE:

The vehicle must be cooled with the hood open.

3. Start engine and let it idle for 5 minutes or more.

### CAUTION:

Never turn ignition switch OFF during idling.

4. Check 1st trip DTC.

Is 1st trip DTC detected?

YES >> Proceed to [EC-282, "Diagnosis Procedure"](#).

NO >> INSPECTION END

## 9. CHECK INTERMITTENT INCIDENT

Refer to [GI-44, "Intermittent Incident"](#).

>> INSPECTION END

## Diagnosis Procedure

INFOID:000000011278007

### 1. CHECK DTC PRIORITY

If DTC P0196 is displayed with DTC P0197 or P0198, first perform the trouble diagnosis for DTC P0197 or P0198.

Is applicable DTC detected?

YES >> Perform diagnosis of applicable. Refer to [EC-96, "DTC Index"](#).

NO >> GO TO 2.

### 2. CHECK ENGINE OIL TEMPERATURE (EOT) SENSOR

Check EOT sensor. Refer to [EC-282, "Component Inspection"](#).

Is the inspection result normal?

YES >> GO TO 3.

NO >> Replace EOT sensor. Refer to [EC-14, "Component Parts Location"](#).

### 3. CHECK INTERMITTENT INCIDENT

Refer to [GI-44, "Intermittent Incident"](#).

>> INSPECTION END

## Component Inspection

INFOID:000000011278008

### 1. CHECK ENGINE OIL TEMPERATURE SENSOR

# P0196 EOT SENSOR

[QR25DE]

## < DTC/CIRCUIT DIAGNOSIS >

1. Turn ignition switch OFF.
2. Disconnect engine oil temperature sensor harness connector.
3. Remove engine oil temperature sensor.
4. Check resistance between engine oil temperature sensor terminals by heating with hot water as shown in the figure.

Engine oil temperature sensor		Condition	Resistance (kΩ)
+	-		
Terminal			
1	2	Temperature [°C (°F)]	
		20 (68)	2.37 - 2.63
		50 (122)	0.68 - 1.00
		90 (194)	0.236 - 0.260

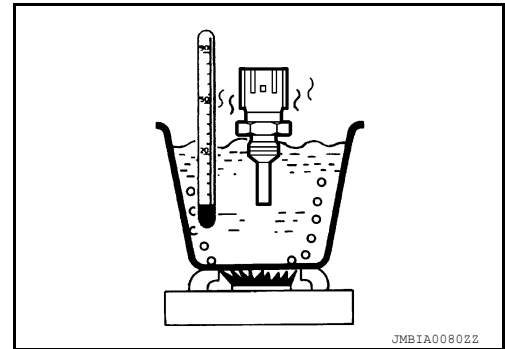

Is the inspection result normal?

YES >> INSPECTION END

NO >> Replace engine oil temperature sensor. Refer to [EC-14, "Component Parts Location"](#).

A  
EC  
C  
D  
E  
F  
G  
H  
I  
J  
K  
L  
M  
N  
O  
P

# P0197, P0198 EOT SENSOR

< DTC/CIRCUIT DIAGNOSIS >

[QR25DE]

## P0197, P0198 EOT SENSOR

### DTC Description

INFOID:000000011278009

### DTC DETECTION LOGIC

DTC No.	CONSULT screen terms (Trouble diagnosis content)	DTC detecting condition
P0197	EOT SEN/CIRC (Engine oil temperature sensor low)	An excessively low voltage from the engine oil temperature sensor is sent to ECM.
P0198	EOT SEN/CIRC (Engine oil temperature sensor high)	An excessively high voltage from the engine oil temperature sensor is sent to ECM.

### POSSIBLE CAUSE

- Harness or connectors (EOT sensor circuit is open or shorted.)
- Engine oil temperature sensor

### FAIL-SAFE

Exhaust valve timing control does not function.

### DTC CONFIRMATION PROCEDURE

#### 1. PRECONDITIONING

If DTC Confirmation Procedure has been previously conducted, always perform the following procedure before conducting the next test.

1. Turn ignition switch OFF and wait at least 10 seconds.
2. Turn ignition switch ON.
3. Turn ignition switch OFF and wait at least 10 seconds.

>> GO TO 2.

#### 2. PERFORM DTC CONFIRMATION PROCEDURE

1. Start engine and wait at least 5 seconds.
2. Check 1st trip DTC.

#### Is 1st trip DTC detected?

- YES >> Proceed to [EC-284, "Diagnosis Procedure"](#).  
NO >> INSPECTION END

### Diagnosis Procedure

INFOID:000000011278010

#### 1. CHECK ENGINE OIL TEMPERATURE SENSOR POWER SUPPLY

1. Turn ignition switch OFF.
2. Disconnect engine oil temperature (EOT) sensor harness connector.
3. Turn ignition switch ON.
4. Check the voltage between EOT sensor harness connector and ground.

+		-	Voltage (Approx.)
EOT sensor			
Connector	Terminal		
F68	1	Ground	5 V

#### Is the inspection result normal?

- YES >> GO TO 3.  
NO >> GO TO 2.

#### 2. CHECK ENGINE OIL TEMPERATURE SENSOR POWER SUPPLY CIRCUIT

1. Turn ignition switch OFF.
2. Disconnect ECM harness connector.

# P0197, P0198 EOT SENSOR

[QR25DE]

## < DTC/CIRCUIT DIAGNOSIS >

3. Check the continuity between EOT sensor harness connector and ECM harness connector.

+		-		Continuity
EOT sensor		ECM		
Connector	Terminal	Connector	Terminal	
F68	1	F51	25	Existed

4. Also check harness for short to ground.

Is the inspection result normal?

- YES >> Perform the trouble diagnosis for power supply circuit.  
 NO >> Repair or replace error-detected parts.

### 3.CHECK EOT SENSOR GROUND CIRCUIT

1. Turn ignition switch OFF.
2. Disconnect ECM harness connector.
3. Check the continuity between EOT sensor harness connector and ECM harness connector.

+		-		Continuity
EOT sensor		ECM		
Connector	Terminal	Connector	Terminal	
F68	2	F51	26	Existed

4. Also check harness for short to power.

Is the inspection result normal?

- YES >> GO TO 4.  
 NO >> Repair or replace error-detected parts.

### 4.CHECK ENGINE OIL TEMPERATURE SENSOR

Check the engine oil temperature sensor. Refer to [EC-282, "Component Inspection"](#).

Is the inspection result normal?

- YES >> GO TO 5.  
 NO >> Replace engine oil temperature sensor. Refer to [EC-14, "Component Parts Location"](#).

### 5.CHECK INTERMITTENT INCIDENT

Refer to [GI-44, "Intermittent Incident"](#).

>> INSPECTION END

## Component Inspection

INFOID:0000000011278011

### 1.CHECK ENGINE OIL TEMPERATURE SENSOR

1. Turn ignition switch OFF.
2. Disconnect engine oil temperature sensor harness connector.
3. Remove engine oil temperature sensor.
4. Check resistance between engine oil temperature sensor terminals by heating with hot water as shown in the figure.

Engine oil temperature sensor		Condition	Resistance (kΩ)	
+	-			
Terminal				
1	2	Temperature [°C (°F)]	20 (68)	2.37 - 2.63
			50 (122)	0.68 - 1.00
			90 (194)	0.236 - 0.260

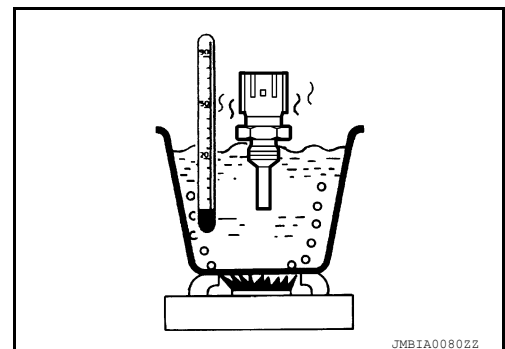

## P0197, P0198 EOT SENSOR

[QR25DE]

< DTC/CIRCUIT DIAGNOSIS >

---

Is the inspection result normal?

YES >> INSPECTION END

NO >> Replace engine oil temperature sensor. Refer to [EC-14, "Component Parts Location"](#).

# P0222, P0223 TP SENSOR

< DTC/CIRCUIT DIAGNOSIS >

[QR25DE]

## P0222, P0223 TP SENSOR

### DTC Description

INFOID:000000011278012

### DTC DETECTION LOGIC

DTC No.	CONSULT screen terms (Trouble diagnosis content)	DTC detecting condition
P0222	TP SEN 1/CIRC-B1 (Throttle/pedal position sensor/switch "B" circuit low)	An excessively low voltage from the TP sensor 1 is sent to ECM.
P0223	TP SEN 1/CIRC-B1 (Throttle/pedal position sensor/switch "B" circuit high)	An excessively high voltage from the TP sensor 1 is sent to ECM.

### POSSIBLE CAUSE

- Harness or connectors (TP sensor 1 circuit is open or shorted.)
- Electric throttle control actuator (TP sensor 1)

### FAIL-SAFE

- The ECM controls the electric throttle control actuator in regulating the throttle opening in order for the idle position to be within +10 degrees.
- The ECM regulates the opening speed of the throttle valve to be slower than the normal condition. So, the acceleration will be poor.

### DTC CONFIRMATION PROCEDURE

#### 1.CHECK DTC PRIORITY

If DTC P0222 or P0223 is displayed with DTC P0643, first perform the trouble diagnosis for DTC P0643.

#### Is applicable DTC detected?

- YES >> Perform diagnosis of applicable. Refer to [EC-382, "DTC Description"](#).  
NO >> GO TO 2.

#### 2.PRECONDITIONING

If DTC Confirmation Procedure has been previously conducted, always perform the following procedure before conducting the next test.

1. Turn ignition switch OFF and wait at least 10 seconds.
2. Turn ignition switch ON.
3. Turn ignition switch OFF and wait at least 10 seconds.

#### **TESTING CONDITION:**

**Before performing the following procedure, confirm that battery voltage is more than 8 V at idle.**

>> GO TO 3.

#### 3.PERFORM DTC CONFIRMATION PROCEDURE

1. Start engine and let it idle for 1 second.
2. Check DTC.

#### Is DTC detected?

- YES >> Proceed to [EC-287, "Diagnosis Procedure"](#).  
NO >> INSPECTION END

### Diagnosis Procedure

INFOID:000000011278013

#### 1.CHECK DTC PRIORITY

If DTC P0222 or P0223 is displayed with DTC P0643, first perform the trouble diagnosis for DTC P0643.

#### Is applicable DTC detected?

- YES >> Perform diagnosis of applicable. Refer to [EC-382, "DTC Description"](#).  
NO >> GO TO 2.

# P0222, P0223 TP SENSOR

[QR25DE]

< DTC/CIRCUIT DIAGNOSIS >

## 2. CHECK THROTTLE POSITION SENSOR 1 POWER SUPPLY

1. Turn ignition switch OFF.
2. Disconnect electric throttle control actuator harness connector.
3. Turn ignition switch ON.
4. Check the voltage between electric throttle control actuator harness connector and ground.

+		-	Voltage (Approx.)
Electric throttle control actuator			
Connector	Terminal		
F50	2	Ground	5 V

Is the inspection result normal?

YES >> GO TO 4.

NO >> GO TO 3.

## 3. CHECK THROTTLE POSITION SENSOR 1 POWER SUPPLY CIRCUIT

1. Turn ignition switch OFF.
2. Disconnect ECM harness connector.
3. Check the continuity between electric throttle control actuator harness connector and ECM harness connector.

+		-		Continuity
Electric throttle control actuator		ECM		
Connector	Terminal	Connector	Terminal	
F50	2	F52	80	Existed

4. Also check harness for short to ground.

Is the inspection result normal?

YES >> Perform the trouble diagnosis for power supply circuit.

NO >> Repair or replace error-detected parts.

## 4. CHECK THROTTLE POSITION SENSOR 1 GROUND CIRCUIT

1. Turn ignition switch OFF.
2. Disconnect ECM harness connector.
3. Check the continuity between electric throttle control actuator harness connector and ECM harness connector.

+		-		Continuity
Electric throttle control actuator		ECM		
Connector	Terminal	Connector	Terminal	
F50	4	F52	78	Existed

4. Also check harness for short to power.

Is the inspection result normal?

YES >> GO TO 5.

NO >> Repair or replace error-detected parts.

## 5. CHECK THROTTLE POSITION SENSOR 1 INPUT SIGNAL CIRCUIT

1. Check the continuity between electric throttle control actuator harness connector and ECM harness connector.



# P0222, P0223 TP SENSOR

< DTC/CIRCUIT DIAGNOSIS >

[QR25DE]

+		-		Continuity
Electric throttle control actuator		ECM		
Connector	Terminal	Connector	Terminal	
F50	1	F52	79	Existed

2. Also check harness for short to ground and to power.

Is the inspection result normal?

YES >> GO TO 6.

NO >> Repair open circuit or short to ground or short to power in harness or connectors.

## 6. CHECK THROTTLE POSITION SENSOR

Check the throttle position sensor. Refer to [EC-289, "Component Inspection"](#).

Is the inspection result normal?

YES >> GO TO 7.

NO >> Replace electric throttle control actuator. Refer to [EM-29, "Removal and Installation"](#).

## 7. CHECK INTERMITTENT INCIDENT

Refer to [GI-44, "Intermittent Incident"](#).

>> INSPECTION END

## Component Inspection

INFOID:0000000011278014

## 1. CHECK THROTTLE POSITION SENSOR

1. Turn ignition switch OFF.
2. Reconnect all harness connectors disconnected.
3. Perform "Throttle Valve Closed Position Learning". Refer to [EC-143, "Work Procedure"](#).
4. Turn ignition switch ON.
5. Set selector lever to D position.
6. Check the voltage between ECM harness connector terminals as per the following conditions.

ECM				Condition	Voltage
Connector	+	-	Terminal		
Sensor 1	F52	79	78	Fully released	More than 0.36V
					Fully depressed
Sensor 2	F52	77	78	Fully released	Less than 4.75V
					Fully depressed

Is the inspection result normal?

YES >> INSPECTION END

NO >> Replace electric throttle control actuator. Refer to [EM-29, "Removal and Installation"](#).

# P0300, P0301, P0302, P0303, P0304 MISFIRE

< DTC/CIRCUIT DIAGNOSIS >

[QR25DE]

## P0300, P0301, P0302, P0303, P0304 MISFIRE

### DTC Description

INFOID:000000011278015

### DTC DETECTION LOGIC

When a misfire occurs, engine speed will fluctuate. If the engine speed fluctuates enough to cause the crankshaft position (CKP) sensor (POS) signal to vary, ECM can determine that a misfire is occurring.

Sensor	Input signal to ECM	ECM function
Crankshaft position sensor (POS)	Engine speed	On board diagnosis of misfire

The misfire detection logic consists of the following two conditions.

- One Trip Detection Logic (Three Way Catalyst Damage)**  
On the 1st trip, when a misfire condition occurs that can damage the three way catalyst (TWC) due to overheating, the MIL will blink.  
When a misfire condition occurs, the ECM monitors the CKP sensor signal every 200 engine revolutions for a change.  
When the misfire condition decreases to a level that will not damage the TWC, the MIL will turn off.  
If another misfire condition occurs that can damage the TWC on a second trip, the MIL will blink.  
When the misfire condition decreases to a level that will not damage the TWC, the MIL will remain on.  
If another misfire condition occurs that can damage the TWC, the MIL will begin to blink again.
- Two Trip Detection Logic (Exhaust quality deterioration)**  
For misfire conditions that will not damage the TWC (but will affect vehicle emissions), the MIL will only light when the misfire is detected on a second trip. During this condition, the ECM monitors the CKP sensor signal every 1,000 engine revolutions.  
A misfire malfunction can be detected on any one cylinder or on multiple cylinders.

DTC No.	CONSULT screen terms (Trouble diagnosis content)	DTC detecting condition
P0300	MULTI CYL MISFIRE (Random/multiple cylinder misfire detected)	Multiple cylinder misfire.
P0301	CYL 1 MISFIRE (Cylinder 1 Misfire Detected)	No. 1 cylinder misfires.
P0302	CYL 2 MISFIRE (Cylinder 2 Misfire Detected)	No. 2 cylinder misfires.
P0303	CYL 3 MISFIRE (Cylinder 3 Misfire Detected)	No. 3 cylinder misfires.
P0304	CYL 4 MISFIRE (Cylinder 4 Misfire Detected)	No. 4 cylinder misfires.

### POSSIBLE CAUSE

- Improper spark plug
- Insufficient compression
- Incorrect fuel pressure
- Fuel Injector circuit is open or shorted
- Fuel injector
- Intake air leak
- Ignition signal circuit is open or shorted
- Lack of fuel
- Signal plate
- A/F sensor 1
- Incorrect PCV hose connection

### FAIL-SAFE

Traveling control mode (Accelerator angle variation control)

### DTC CONFIRMATION PROCEDURE

#### 1. PRECONDITIONING

# P0300, P0301, P0302, P0303, P0304 MISFIRE

[QR25DE]

## < DTC/CIRCUIT DIAGNOSIS >

If DTC Confirmation Procedure has been previously conducted, always perform the following procedure before conducting the next test.

1. Turn ignition switch OFF and wait at least 10 seconds.
2. Turn ignition switch ON.
3. Turn ignition switch OFF and wait at least 10 seconds.

>> GO TO 2.

## 2.PERFORM DTC CONFIRMATION PROCEDURE-1

1. Start engine and warm it up to normal operating temperature.
2. Turn ignition switch OFF and wait at least 10 seconds.
3. Restart engine and let it idle for about 15 minutes.
4. Check 1st trip DTC.

Is 1st trip DTC detected?

- YES >> Proceed to [EC-291, "Diagnosis Procedure"](#).  
NO >> GO TO 3.

## 3.PERFORM DTC CONFIRMATION PROCEDURE-2

1. Turn ignition switch OFF and wait at least 10 seconds.
2. Start engine and drive the vehicle as per the similar conditions to (1st trip) Freeze Frame Data for a certain time. Refer to the table below.

**Hold the accelerator pedal as steady as possible.**

The similar conditions to (1st trip) Freeze Frame Data means the vehicle operation that the following conditions should be satisfied at the same time.

**CAUTION:**

**Always drive vehicle in safe manner according to traffic conditions and obey all traffic laws when driving.**

Engine speed	Engine speed in the freeze frame data $\pm$ 400 rpm
Vehicle speed	Vehicle speed in the freeze frame data $\pm$ 10 km/h (6 MPH)
Engine coolant temperature (T) condition	When the freeze frame data shows lower than 70°C (158°F), T should be lower than 70°C (158°F).
	When the freeze frame data shows higher than or equal to 70°C (158°F), T should be higher than or equal to 70°C (158°F).

The time to driving varies according to the engine speed in the freeze frame data.

Engine speed	Time
Around 1,000 rpm	Approximately 10 minutes
Around 2,000 rpm	Approximately 5 minutes
More than 3,000 rpm	Approximately 3.5 minutes

3. Check 1st trip DTC.

Is 1st trip DTC detected?

- YES >> Proceed to [EC-291, "Diagnosis Procedure"](#).  
NO >> INSPECTION END

## Diagnosis Procedure

INFOID:000000011278016

## 1.CHECK FOR INTAKE AIR LEAK AND PCV HOSE

1. Start engine and run it at idle speed.
2. Listen for the sound of the intake air leak.
3. Check PCV hose connection.

Is intake air leak detected?

- YES >> Discover air leak location and repair.  
NO >> GO TO 2.

# P0300, P0301, P0302, P0303, P0304 MISFIRE

< DTC/CIRCUIT DIAGNOSIS >

[QR25DE]

## 2. CHECK FOR EXHAUST SYSTEM CLOGGING

Stop engine and visually check exhaust tube, three way catalyst and muffler for dents.

Is the inspection result normal?

- YES-1 >> With CONSULT: GO TO 3.
- YES-2 >> Without CONSULT: GO TO 4.
- NO >> Repair or replace it.

## 3. PERFORM POWER BALANCE TEST

Ⓟ With CONSULT

1. Start engine.
2. Perform "POWER BALANCE" in "ACTIVE TEST" mode of "ENGINE" using CONSULT.
3. Make sure that each circuit produces a momentary engine speed drop.

Is the inspection result normal?

- YES >> GO TO 9.
- NO >> GO TO 4.

## 4. CHECK FUNCTION OF FUEL INJECTOR

1. Start engine and let engine idle.
2. Listen to each fuel injector operating sound.

**Clicking noise should be heard.**

Is the inspection result normal?

- YES >> GO TO 5.
- NO >> Perform trouble diagnosis for FUEL INJECTOR. Refer to [EC-467, "Diagnosis Procedure"](#).

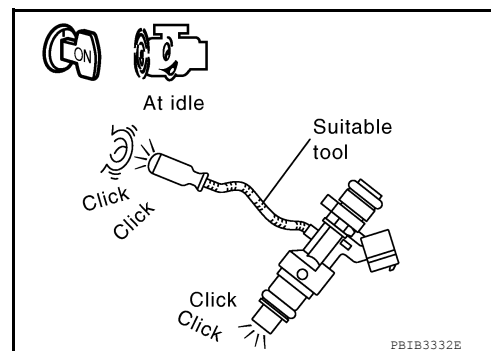

## 5. CHECK FUNCTION OF IGNITION COIL-1

### CAUTION:

**Do the following procedure in the place where ventilation is good without the combustible.**

1. Turn ignition switch OFF.
2. Remove fuel pump fuse in IPDM E/R to release fuel pressure.

### NOTE:

Do not use CONSULT to release fuel pressure, or fuel pressure applies again during the following procedure.

3. Start engine.
4. After engine stalls, crank it two or three times to release all fuel pressure.
5. Turn ignition switch OFF.
6. Remove all ignition coil harness connectors to avoid the electrical discharge from the ignition coils.
7. Remove ignition coil and spark plug of the cylinder to be checked.
8. Crank engine for 5 seconds or more to remove combustion gas in the cylinder.
9. Connect spark plug and harness connector to ignition coil.
10. Fix ignition coil using a rope etc. with gap of 13 - 17 mm (0.52 - 0.66 in) between the edge of the spark plug and grounded metal portion as shown in the figure.
11. Crank engine for about 3 seconds, and check whether spark is generated between the spark plug and the grounded metal portion.

**Spark should be generated.**

### CAUTION:

- Do not approach to the spark plug and the ignition coil within 50 cm (19.7 in). Be careful not to get an electrical shock while checking, because the electrical discharge voltage becomes 20 kV or more.

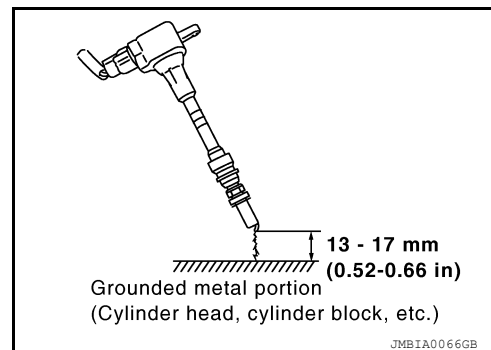

# P0300, P0301, P0302, P0303, P0304 MISFIRE

< DTC/CIRCUIT DIAGNOSIS >

[QR25DE]

- It might cause to damage the ignition coil if the gap of more than 17 mm (0.66 in) is taken.

**NOTE:**

When the gap is less than 13 mm (0.52 in), the spark might be generated even if the coil is malfunctioning.

Is the inspection result normal?

- YES >> GO TO 9.
- NO >> GO TO 6.

## 6. CHECK FUNCTION OF IGNITION COIL-2

1. Turn ignition switch OFF.
2. Disconnect spark plug and connect a known-good spark plug.
3. Crank engine for about 3 seconds, and recheck whether spark is generated between the spark plug and the grounded metal portion.

**Spark should be generated.**

Is the inspection result normal?

- YES >> GO TO 7.
- NO >> Check ignition coil, power transistor and their circuits. Refer to [EC-473, "Diagnosis Procedure"](#).

## 7. CHECK SPARK PLUG

Check the initial spark plug for fouling, etc.

Is the inspection result normal?

- YES >> Replace spark plug(s) with standard type one(s). For spark plug type, refer to [EM-120, "Spark Plug"](#).
- NO >> Repair or clean spark plug. Then GO TO 8.

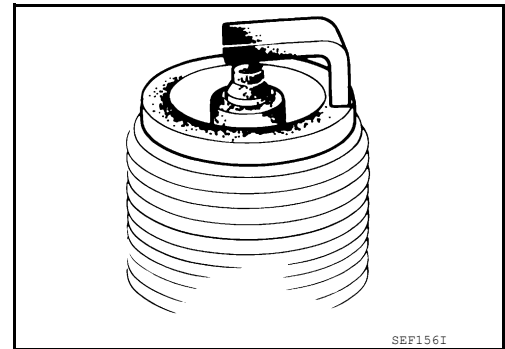

## 8. CHECK FUNCTION OF IGNITION COIL-3

1. Reconnect the initial spark plugs.
2. Crank engine for about 3 seconds, and recheck whether spark is generated between the spark plug and the grounded portion.

**Spark should be generated.**

Is the inspection result normal?

- YES >> INSPECTION END
- NO >> Replace spark plug(s) with standard type one(s). For spark plug type. Refer to [EM-120, "Spark Plug"](#).

## 9. CHECK COMPRESSION PRESSURE

Check compression pressure. Refer to [EM-24, "Compression pressure"](#).

Is the inspection result normal?

- YES >> GO TO 10.
- NO >> Check pistons, piston rings, valves, valve seats and cylinder head gaskets.

## 10. CHECK FUEL PRESSURE

1. Install all removed parts.
2. Release fuel pressure to zero.
3. Install fuel pressure gauge and check fuel pressure. Refer to [EC-147, "Work Procedure"](#).

**At idling: Approximately 350 kPa (3.57 kg/cm<sup>2</sup>, 51 psi)**

Is the inspection result normal?

- YES >> GO TO 12.

# P0300, P0301, P0302, P0303, P0304 MISFIRE

[QR25DE]

## < DTC/CIRCUIT DIAGNOSIS >

NO >> GO TO 11.

### 11. DETECT MALFUNCTIONING PART

Check fuel hoses and fuel tubes for clogging.

Is the inspection result normal?

YES >> Replace "fuel filter and fuel pump assembly". Refer to [FL-5, "Removal and Installation"](#).

NO >> Repair or replace.

### 12. CHECK IGNITION TIMING

Check the following items.

For procedure, refer to [EC-135, "Work Procedure"](#).

For specification, refer to [EC-503, "Ignition Timing"](#).

Is the inspection result normal?

YES >> GO TO 13.

NO >> Follow the [EC-135, "Work Procedure"](#).

### 13. CHECK A/F SENSOR 1 INPUT SIGNAL CIRCUIT

1. Turn ignition switch OFF.
2. Disconnect A/F sensor 1 harness connector.
3. Disconnect ECM harness connector.
4. Check the continuity between A/F sensor 1 harness connector and ECM harness connector.

+		-		Continuity
A/F sensor 1		ECM		
Connector	Terminal	Connector	Terminal	
F18	1	F51	41	Existed

5. Check the continuity between A/F sensor 1 harness connector or ECM harness connector and ground.

+		-	Continuity
A/F sensor 1			
Connector	Terminal		
F18	1	Ground	Not existed

+		-	Continuity
ECM			
Connector	Terminal		
F51	41	Ground	Not existed

6. Also check harness for short to power.

Is the inspection result normal?

YES >> GO TO 14.

NO >> Repair open circuit or short to ground or short to power in harness or connectors.

### 14. CHECK A/F SENSOR 1 HEATER

Check the A/F sensor 1 heater. Refer to [EC-189, "Component Inspection"](#).

Is the inspection result normal?

YES >> GO TO 15.

NO >> Replace A/F sensor 1. Refer to [EM-32, "Exploded View"](#).

### 15. CHECK MASS AIR FLOW SENSOR

 With CONSULT

1. Install all removed parts.
2. Start engine and warm it up to normal operating temperature.
3. Check "MASS AIR FLOW SENSOR (Hz)" in "DATA MONITOR" mode of "ENGINE" using CONSULT.

# P0300, P0301, P0302, P0303, P0304 MISFIRE

< DTC/CIRCUIT DIAGNOSIS >

[QR25DE]

Monitor item	Condition	Value
MASS AIR FLOWSENSOR (Hz)	Ignition switch ON (Engine stopped.)	Approx. 3500 Hz
	Idle (Engine is warmed-up to normal operating temperature.)	3500- 4100 Hz
	2,500 rpm (Engine is warmed-up to normal operating temperature.)	5100 - 5600 Hz
	Idle to about 4,000 rpm	3500 - 4100 Hz to Approx. 6300 Hz*

\*: Check for linear frequency rise in response to engine being increased to about 4,000 rpm.

⊗ Without CONSULT

1. Install all removed parts.
2. Start engine and warm it up to normal operating temperature.
3. Check mass air flow sensor signal in Service \$01 with GST.

ECM			Condition	Value
Connector	+	-		
	Terminal			
F51	35	34	Ignition switch ON (Engine stopped.)	Approx. 3500 Hz
			Idle (Engine is warmed-up to normal operating temperature.)	3500- 4100 Hz
			2,500 rpm (Engine is warmed-up to normal operating temperature.)	5100 - 5600 Hz
			Idle to about 4,000 rpm	3500 - 4100 Hz to Approx. 6300 Hz*
			Ignition switch ON (Engine stopped.)	Approx. 3500 Hz

\*: Check for linear frequency rise in response to engine being increased to about 4,000 rpm.

Is the measurement value within the specification?

YES >> GO TO 16.

NO >> Check connectors for rusted terminals or loose connections in the mass air flow sensor circuit or ground. Refer to [EC-205, "DTC Description"](#).

## 16.CHECK SYMPTOM TABLE

Check items on the rough idle symptom in [EC-489, "Symptom Table"](#).

Is the inspection result normal?

YES >> GO TO 17.

NO >> Repair or replace error-detected parts.

## 17.ERASE THE 1ST TRIP DTC

Some tests may cause a 1st trip DTC to be set.

Erase the 1st trip DTC from the ECM memory after performing the tests. Refer to [EC-58, "Diagnosis Description"](#).

>> GO TO 18.

## 18.CHECK INTERMITTENT INCIDENT

Refer to [GI-44, "Intermittent Incident"](#).

>> INSPECTION END

P0327, P0328 KS

DTC Description

INFOID:000000011278017

DTC DETECTION LOGIC

DTC No.	CONSULT screen terms (Trouble diagnosis content)	DTC detecting condition
P0327	KNOCK SEN/CIRC-B1 (Knock sensor 1 circuit low bank 1 or single sensor)	An excessively low voltage from the knock sensor is sent to ECM.
P0328	KNOCK SEN/CIRC-B1 (Knock sensor 1 circuit high bank 1 or single sensor)	An excessively high voltage from the knock sensor is sent to ECM.

POSSIBLE CAUSE

- Harness or connectors (Knock sensor circuit is open or shorted.)
- Knock sensor

FAIL-SAFE

Not applicable

DTC CONFIRMATION PROCEDURE

1. PRECONDITIONING

If DTC Confirmation Procedure has been previously conducted, always perform the following procedure before conducting the next test.

1. Turn ignition switch OFF and wait at least 10 seconds.
2. Turn ignition switch ON.
3. Turn ignition switch OFF and wait at least 10 seconds.

**TESTING CONDITION:**

**Before performing the following procedure, confirm that battery voltage is more than 10 V at idle.**

>> GO TO 2.

2. PERFORM DTC CONFIRMATION PROCEDURE

1. Start engine and run it for at least 5 seconds at idle speed.
2. Check 1st trip DTC.

Is 1st trip DTC detected?

- YES >> Proceed to [EC-296. "Diagnosis Procedure"](#).
- NO >> INSPECTION END

Diagnosis Procedure

INFOID:000000011278018

1. CHECK KNOCK SENSOR GROUND CIRCUIT

1. Turn ignition switch OFF.
2. Disconnect knock sensor harness connector.
3. Disconnect ECM harness connector.
4. Check the continuity between knock sensor harness connector and ECM harness connector.

+		-		Continuity
Knock sensor		ECM		
Connector	Terminal	Connector	Terminal	
F9	2	F51	8	Existed

5. Also check harness for short to power.

Is the inspection result normal?

- YES >> GO TO 2.



< DTC/CIRCUIT DIAGNOSIS >

NO >> Repair or replace error-detected parts.

**2.CHECK KNOCK SENSOR INPUT SIGNAL CIRCUIT**

1. Check the continuity between knock sensor harness connector and ECM harness connector.

+		-		Continuity
Knock sensor		ECM		
Connector	Terminal	Connector	Terminal	
F9	1	F51	4	Existed

2. Also check harness for short to ground and to power.

Is the inspection result normal?

YES >> GO TO 3.

NO >> Repair open circuit or short to ground or short to power in harness or connectors.

**3.CHECK KNOCK SENSOR**

Check the knock sensor. Refer to [EC-297, "Component Inspection"](#).

Is the inspection result normal?

YES >> GO TO 4.

NO >> Replace knock sensor. Refer to [EM-97, "Exploded View"](#).

**4.CHECK INTERMITTENT INCIDENT**

Refer to [GI-44, "Intermittent Incident"](#).

>> INSPECTION END

**Component Inspection**

INFOID:0000000011278019

**1.CHECK KNOCK SENSOR**

1. Turn ignition switch OFF.
2. Disconnect knock sensor harness connector.
3. Check resistance between knock sensor terminals as per the following.

**NOTE:**

**It is necessary to use an ohmmeter which can measure more than 10 MΩ.**

Knock sensor		Resistance
+	-	
Terminals		
1	2	Approx. 532 - 588 kΩ [at 20°C (68°F)]

**CAUTION:**

**Do not use any knock sensors that have been dropped or physically damaged. Use only new ones.**

Is the inspection result normal?

YES >> INSPECTION END

NO >> Replace knock sensor. Refer to [EM-97, "Exploded View"](#).

# P0335 CKP SENSOR (POS)

[QR25DE]

< DTC/CIRCUIT DIAGNOSIS >

## P0335 CKP SENSOR (POS)

### DTC Description

INFOID:000000011278020

### DTC DETECTION LOGIC

DTC No.	CONSULT screen terms (Trouble diagnosis content)	DTC detecting condition
P0335	CKP SEN/CIRCUIT (Crankshaft position sensor "A" circuit)	<ul style="list-style-type: none"><li>The crankshaft position sensor (POS) signal is not detected by the ECM during the first few seconds of engine cranking.</li><li>The proper pulse signal from the crankshaft position sensor (POS) is not sent to ECM while the engine is running.</li><li>The crankshaft position sensor (POS) signal is not in the normal pattern during engine running.</li></ul>

### POSSIBLE CAUSE

- Harness or connectors [Crankshaft position sensor (POS) circuit is open or shorted.]
- Crankshaft position sensor (POS)
- Signal plate
- Sensor power supply 2 circuit

### FAIL-SAFE

Not applicable

### DTC CONFIRMATION PROCEDURE

#### 1.CHECK DTC PRIORITY

If DTC P0335 is displayed with DTC P0643, first perform the trouble diagnosis for DTC P0643.

Is applicable DTC detected?

- YES >> Perform diagnosis of applicable. Refer to [EC-382, "DTC Description"](#).  
NO >> GO TO 2.

#### 2.PRECONDITIONING

If DTC Confirmation Procedure has been previously conducted, always perform the following procedure before conducting the next test.

- Turn ignition switch OFF and wait at least 10 seconds.
- Turn ignition switch ON.
- Turn ignition switch OFF and wait at least 10 seconds.

#### TESTING CONDITION:

**Before performing the following procedure, confirm that battery voltage is more than 10.5 V with ignition switch ON.**

>> GO TO 3.

#### 3.PERFORM DTC CONFIRMATION PROCEDURE

- Start engine and let it idle for at least 5 seconds.  
If engine does not start, crank engine for at least 2 seconds.
- Check 1st trip DTC.

Is 1st trip DTC detected?

- YES >> Proceed to [EC-298, "Diagnosis Procedure"](#).  
NO >> INSPECTION END

### Diagnosis Procedure

INFOID:000000011278021

#### 1.CHECK DTC PRIORITY

If DTC P0335 is displayed with DTC P0643, first perform the trouble diagnosis for DTC P0643.

Is applicable DTC detected?

- YES >> Perform diagnosis of applicable. Refer to [EC-382, "DTC Description"](#).  
NO >> GO TO 2.

# P0335 CKP SENSOR (POS)

[QR25DE]

< DTC/CIRCUIT DIAGNOSIS >

## 2. CHECK CRANKSHAFT POSITION (CKP) SENSOR (POS) POWER SUPPLY

1. Disconnect crankshaft position (CKP) sensor (POS) harness connector.
2. Turn ignition switch ON.
3. Check the voltage between CKP sensor (POS) harness connector and ground.

+		-	Voltage (Approx.)
CKP sensor (POS)			
Connector	Terminal		
F17	1	Ground	5 V

Is the inspection result normal?

YES >> GO TO 4.

NO >> GO TO 3.

## 3. CHECK CKP SENSOR (POS) GROUND CIRCUIT

1. Turn ignition switch OFF.
2. Disconnect ECM harness connector.
3. Check the continuity between CKP sensor (POS) harness connector and ECM harness connector.

+		-		Continuity
CKP sensor (POS)		ECM		
Connector	Terminal	Connector	Terminal	
F17	2	F52	70	Existed

4. Also check harness for short to power.

Is the inspection result normal?

YES >> GO TO 4.

NO >> Repair or replace error-detected parts.

## 4. CHECK CKP SENSOR (POS) INPUT SIGNAL CIRCUIT

1. Check the continuity between CKP sensor (POS) harness connector and ECM harness connector.

+		-		Continuity
CKP sensor (POS)		ECM		
Connector	Terminal	Connector	Terminal	
F17	3	F52	71	Existed

2. Also check harness for short to ground and to power.

Is the inspection result normal?

YES >> GO TO 5.

NO >> Repair or replace error-detected parts.

## 5. CHECK CRANKSHAFT POSITION SENSOR (POS)

Check the crankshaft position sensor (POS). Refer to [EC-300, "Component Inspection \(Crankshaft Position sensor\)"](#).

Is the inspection result normal?

YES >> GO TO 6.

NO >> Replace crankshaft position sensor (POS). Refer to [EM-97, "Exploded View"](#).

## 6. CHECK GEAR TOOTH

1. Remove crankshaft position sensor (POS). Refer to [EM-97, "Exploded View"](#).

# P0335 CKP SENSOR (POS)

[QR25DE]

## < DTC/CIRCUIT DIAGNOSIS >

- Look into the mounting hole<sup>Ⓐ</sup> of the crankshaft position sensor (POS) to check that there is no missing gear tooth in the signal plate<sup>①</sup>.

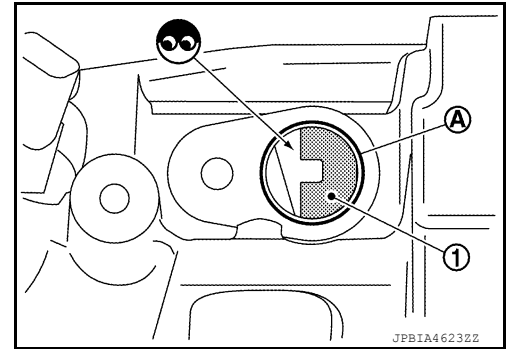

Is the inspection result normal?

YES >> GO TO 7.

NO >> Replace the signal plate. Refer to [EM-97, "Exploded View"](#).

## 7.CHECK INTERMITTENT INCIDENT

Refer to [GI-44, "Intermittent Incident"](#).

>> INSPECTION END

## Component Inspection (Crankshaft Position sensor)

INFOID:000000011278022

### 1.CHECK CRANKSHAFT POSITION SENSOR (POS)-1

- Turn ignition switch OFF.
- Loosen the fixing bolt of the sensor.
- Disconnect crankshaft position sensor (POS) harness connector.
- Remove the sensor.
- Visually check the sensor for chipping.

Is the inspection result normal?

YES >> GO TO 2.

NO >> Replace crankshaft position sensor (POS). Refer to [EM-97, "Exploded View"](#).

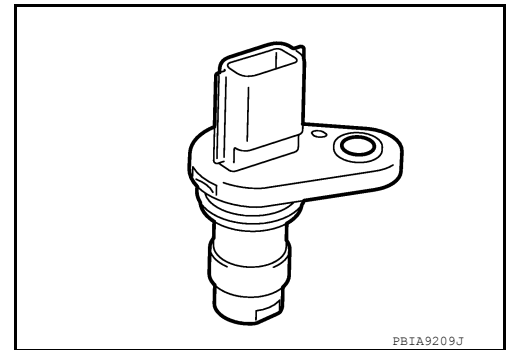

### 2.CHECK CRANKSHAFT POSITION SENSOR (POS)-2

Check the resistance between crankshaft position sensor (POS) terminals as per the following.

Crankshaft position sensor (POS)		Resistance [at 25°C (77°F)]
+	-	
Terminal (Polarity)		Except 0 or ∞ Ω
1	2	
	3	
2	3	

Is the inspection result normal?

YES >> INSPECTION END

NO >> Replace crankshaft position sensor (POS). Refer to [EM-97, "Exploded View"](#).

# P0340 CMP SENSOR (PHASE)

< DTC/CIRCUIT DIAGNOSIS >

[QR25DE]

## P0340 CMP SENSOR (PHASE)

### DTC Description

INFOID:0000000011278023

### DTC DETECTION LOGIC

DTC No.	CONSULT screen terms (Trouble diagnosis content)	DTC detecting condition
P0340	CMP SEN/CIRC-B1 (Camshaft position sensor "A" circuit bank 1 or single sensor)	<ul style="list-style-type: none"><li>The cylinder No. signal is not sent to ECM for the first few seconds during engine cranking.</li><li>The cylinder No. signal is not sent to ECM during engine running.</li><li>The cylinder No. signal is not in the normal pattern during engine running.</li></ul>

### POSSIBLE CAUSE

- Harness or connectors (Camshaft position sensor circuit is open or shorted.)
- Camshaft position sensor
- Camshaft (Intake)
- Starter motor
- Starting system circuit
- Dead (Weak) battery
- Sensor power supply 2 circuit

### FAIL-SAFE

Not applicable

### DTC CONFIRMATION PROCEDURE

#### 1. PRECONDITIONING

If DTC Confirmation Procedure has been previously conducted, always perform the following procedure before conducting the next test.

- Turn ignition switch OFF and wait at least 10 seconds.
- Turn ignition switch ON.
- Turn ignition switch OFF and wait at least 10 seconds.

#### TESTING CONDITION:

**Before performing the following procedure, confirm that battery voltage is more than 10.5 V with ignition switch ON.**

>> GO TO 2.

#### 2. PERFORM DTC CONFIRMATION PROCEDURE-1

- Start engine and let it idle for at least 5 seconds.  
If engine does not start, crank engine for at least 2 seconds.
- Check 1st trip DTC.

#### Is 1st trip DTC detected?

- YES >> Proceed to [EC-301, "Diagnosis Procedure"](#).  
NO >> GO TO 3.

#### 3. PERFORM DTC CONFIRMATION PROCEDURE-2

- Maintaining engine speed at more than 800 rpm for at least 5 seconds.
- Check 1st trip DTC.

#### Is 1st trip DTC detected?

- YES >> Proceed to [EC-301, "Diagnosis Procedure"](#).  
NO >> INSPECTION END

### Diagnosis Procedure

INFOID:0000000011278024

#### 1. CHECK STARTING SYSTEM

Turn ignition switch to START position.

Does the engine turn over? Does the starter motor operate?

# P0340 CMP SENSOR (PHASE)

[QR25DE]

< DTC/CIRCUIT DIAGNOSIS >

YES >> GO TO 2.

NO >> Check starting system (Refer to [STR-11, "Work Flow \(With GR8-1200 NI\)"](#) or [STR-15, "Work Flow \(Without GR8-1200 NI\)"](#)).

## 2. CHECK CAMSHAFT POSITION (CMP) SENSOR (PHASE) POWER SUPPLY

1. Turn ignition switch OFF.
2. Disconnect camshaft position (CMP) sensor (PHASE) harness connector.
3. Turn ignition switch ON.
4. Check the voltage between CMP sensor (PHASE) harness connector and ground.

+		-	Voltage (Approx.)
CMP sensor (PHASE)			
Connector	Terminal	Ground	5 V
F44	1		

Is the inspection result normal?

YES >> GO TO 4.

NO >> GO TO 3.

## 3. CHECK SENSOR POWER SUPPLY 2 CIRCUIT

Perform [EC-487, "Diagnosis Procedure"](#).

Is inspection result normal?

YES >> Perform the trouble diagnosis for power supply circuit.

NO >> Repair or replace error-detected parts.

## 4. CHECK CMP SENSOR (PHASE) GROUND CIRCUIT

1. Turn ignition switch OFF.
2. Disconnect ECM harness connector.
3. Check the continuity between CMP sensor (PHASE) harness connector and ECM harness connector.

+		-		Continuity
CMP sensor (PHASE)		ECM		
Connector	Terminal	Connector	Terminal	Existed
F44	2	F51	30	

4. Also check harness for short to power.

Is the inspection result normal?

YES >> GO TO 5.

NO >> Repair or replace error-detected parts.

## 5. CHECK CMP SENSOR (PHASE) INPUT SIGNAL CIRCUIT

1. Disconnect ECM harness connector.
2. Check the continuity between CMP sensor (PHASE) harness connector and ECM harness connector.

+		-		Continuity
CMP sensor (PHASE)		ECM		
Connector	Terminal	Connector	Terminal	Existed
F44	3	F51	31	

3. Also check harness for short to ground and to power.

Is the inspection result normal?

YES >> GO TO 6.

NO >> Repair or replace error-detected parts.

## 6. CHECK CAMSHAFT POSITION SENSOR (PHASE)

Check the camshaft position sensor (PHASE). Refer to [EC-303, "Component Inspection \(Camshaft position sensor\)"](#).

# P0340 CMP SENSOR (PHASE)

[QR25DE]

< DTC/CIRCUIT DIAGNOSIS >

Is the inspection result normal?

YES >> GO TO 7.

NO >> Replace camshaft position sensor (PHASE). Refer to [EM-69. "Removal and Installation"](#).

## 7. CHECK CAMSHAFT (INT)

Check the following.

- Accumulation of debris to the signal plate of camshaft rear end
- Chipping signal plate of camshaft rear end

Is the inspection result normal?

YES >> GO TO 8.

NO >> Remove debris and clean the signal plate of camshaft rear end or replace camshaft. Refer to [EM-69. "Removal and Installation"](#).

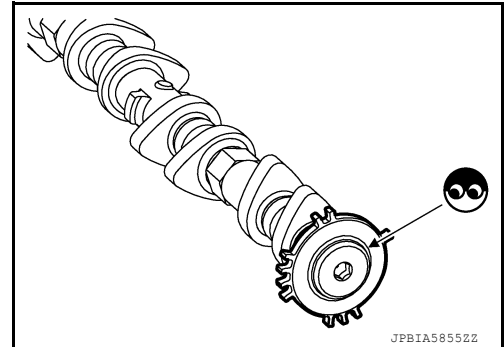

## 8. CHECK INTERMITTENT INCIDENT

Refer to [GI-44. "Intermittent Incident"](#).

>> INSPECTION END

## Component Inspection (Camshaft position sensor)

INFOID:000000011278025

### 1. CHECK CAMSHAFT POSITION SENSOR (PHASE)-1

1. Turn ignition switch OFF.
2. Loosen the fixing bolt of the sensor.
3. Disconnect camshaft position sensor (PHASE) harness connector.
4. Remove the sensor.
5. Visually check the sensor for chipping.

Is the inspection result normal?

YES >> GO TO 2.

NO >> Replace camshaft position sensor (PHASE).

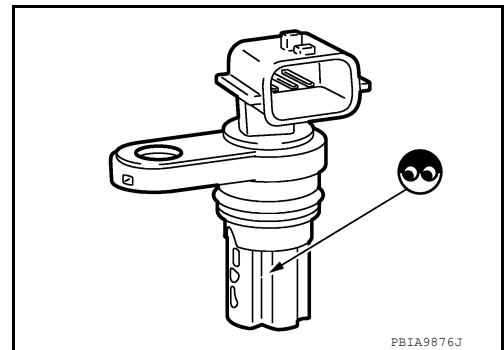

### 2. CHECK CAMSHAFT POSITION SENSOR (PHASE)-2

Check the resistance camshaft position sensor (PHASE) terminals as per the following.

Camshaft position sensor (PHASE)		Resistance [ $\Omega$ at 25°C (77°F)]
+	-	
Terminals (Polarity)		Except 0 or $\infty$
1	2	
	3	
2	3	

Is the inspection result normal?

YES >> INSPECTION END

NO >> Replace camshaft position sensor (PHASE). Refer to [EM-69. "Removal and Installation"](#).

# P0420 THREE WAY CATALYST FUNCTION

< DTC/CIRCUIT DIAGNOSIS >

[QR25DE]

## P0420 THREE WAY CATALYST FUNCTION

### DTC Description

INFOID:000000011278026

### DTC DETECTION LOGIC

The ECM monitors the switching frequency ratio of air fuel ratio (A/F) sensor 1 and heated oxygen sensor 2.

A three way catalyst (manifold) with high oxygen storage capacity will indicate a low switching frequency of heated oxygen sensor 2. As oxygen storage capacity decreases, the heated oxygen sensor 2 switching frequency will increase.

When the frequency ratio of air fuel ratio (A/F) sensor 1 and heated oxygen sensor 2 approaches a specified limit value, the three way catalyst (manifold) malfunction is diagnosed.

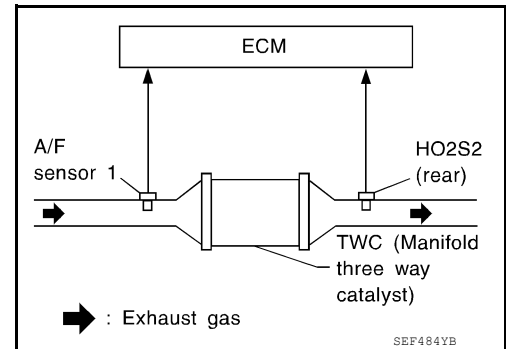

DTC No.	CONSULT screen terms (Trouble diagnosis content)	DTC detecting condition
P0420	TW CATALYST SYS-B1 (Catalyst system efficiency below threshold bank 1)	<ul style="list-style-type: none"> <li>• Three way catalyst (manifold) does not operate properly.</li> <li>• Three way catalyst (manifold) does not have enough oxygen storage capacity.</li> </ul>

### POSSIBLE CAUSE

- Three way catalyst (manifold)
- Exhaust tube
- Intake air leaks
- Fuel injector
- Fuel injector leaks
- Spark plug
- Improper ignition timing

### FAIL-SAFE

Not applicable

### DTC CONFIRMATION PROCEDURE

#### 1. PRECONDITIONING

If DTC Confirmation Procedure has been previously conducted, always perform the following procedure before conducting the next test.

1. Turn ignition switch OFF and wait at least 10 seconds.
2. Turn ignition switch ON.
3. Turn ignition switch OFF and wait at least 10 seconds.

#### Will CONSULT be used?

- YES >> GO TO 2.  
NO >> GO TO 6.

#### 2. PERFORM DTC CONFIRMATION PROCEDURE-1

Ⓜ With CONSULT

#### TESTING CONDITION:

**Do not hold engine speed for more than the specified minutes below.**

1. Start engine and warm it up to the normal operating temperature.
2. Turn ignition switch OFF and wait at least 10 seconds.
3. Turn ignition switch ON.
4. Turn ignition switch OFF and wait at least 10 seconds.
5. Start engine and keep the engine speed between 3,500 and 4,000 rpm for at least 1 minute under no load.
6. Let engine idle for 1 minute.
7. Select "DATA MONITOR" mode of "ENGINE" using CONSULT.
8. Check that "COOLAN TEMP/S" indicates more than 70°C (158°F).



# P0420 THREE WAY CATALYST FUNCTION

[QR25DE]

## < DTC/CIRCUIT DIAGNOSIS >

- If not, warm up engine and go to next step when "COOLAN TEMP/S" indication reaches to 70°C (158°F).
- Open engine hood.
  - Select "DTC & SRT CONFIRMATION" then "SRT WORK SUPPORT" mode of "ENGINE" using CONSULT.
  - Rev engine up to 2,500 to 3,000 rpm and hold it for 3 consecutive minutes then release the accelerator pedal completely.
  - Check the indication of "CATALYST".

Which is displayed on CONSULT screen?

- CMPLT >> GO TO 5.  
INCMP >> GO TO 3.

### 3.PERFORM DTC CONFIRMATION PROCEDURE-2

- Wait 5 seconds at idle.
- Rev engine up to 2,500 to 3,000 rpm and maintain it until "INCMP" of "CATALYST" changes to "CMPLT" (It will take approximately 5 minutes).

Does the indication change to "CMPLT"?

- YES >> GO TO 5.  
NO >> GO TO 4.

### 4.PERFORM DTC CONFIRMATION PROCEDURE AGAIN

- Stop engine and cool it down to less than 70°C (158°F).
- Perform DTC confirmation procedure again.

>> GO TO 2.

### 5.PERFORM DTC CONFIRMATION PROCEDURE-3

Check 1st trip DTC.

Is 1st trip DTC detected?

- YES >> Proceed to [EC-305, "Diagnosis Procedure"](#).  
NO >> INSPECTION END

### 6.PERFORM COMPONENT FUNCTION CHECK

Without CONSULT

- Start engine and warm it up to the normal operating temperature.
- Turn ignition switch OFF and wait at least 10 seconds.
- Restart engine and keep the engine speed between 3,500 and 4,000 rpm for at least 1 minute under no load.
- Let engine idle for 1 minute.
- Open engine hood.
- Check the voltage between ECM harness connector terminals as per the following condition.

ECM			Condition	Voltage (V)
Connector	+	-		
Terminal				
F51	22	23	Keeping engine speed at 2500 rpm constant under no load	The voltage fluctuation cycle takes more than 5 seconds. • 1 cycle: 0.6 - 1.0 → 0 - 0.3 → 0.6 - 1.0

Is the inspection result normal?

- YES >> INSPECTION END  
NO >> Proceed to [EC-305, "Diagnosis Procedure"](#).

## Diagnosis Procedure

INFOID:000000011278027

### 1.CHECK EXHAUST SYSTEM

Visually check exhaust tubes and muffler for dent.

Is the inspection result normal?

# P0420 THREE WAY CATALYST FUNCTION

[QR25DE]

## < DTC/CIRCUIT DIAGNOSIS >

- YES >> GO TO 2.  
NO >> Repair or replace error-detected parts.

### 2.CHECK EXHAUST GAS LEAK

1. Start engine and run it at idle.
2. Listen for an exhaust gas leak before the three way catalyst (manifold).

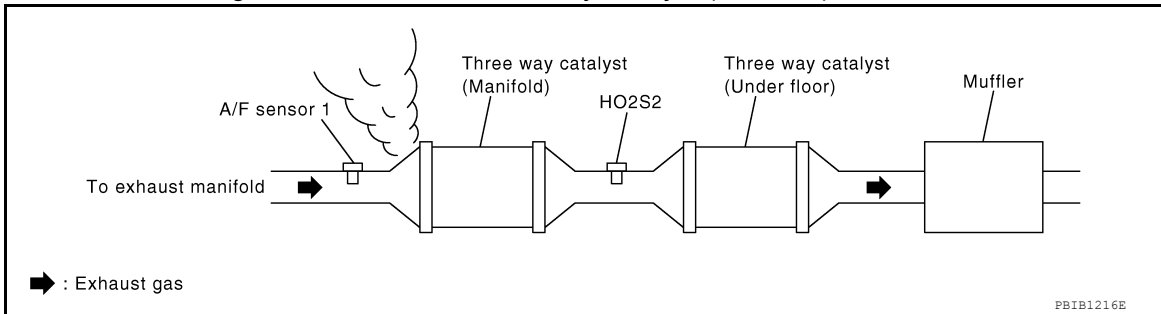

#### Is exhaust gas leak detected?

- YES >> Repair or replace error-detected parts.  
NO >> GO TO 3.

### 3.CHECK INTAKE AIR LEAK

Listen for an intake air leak after the mass air flow sensor.

#### Is intake air leak detected?

- YES >> Repair or replace error-detected parts.  
NO >> GO TO 4.

### 4.CHECK IGNITION TIMING AND IDLE SPEED

Check the following items. Refer to [EC-135, "Work Procedure"](#).

For specification, refer to [EC-503, "Ignition Timing"](#)

For specification, refer to [EC-503, "Idle Speed"](#).

#### Is the inspection result normal?

- YES >> GO TO 5.  
NO >> Follow the [EC-135, "Work Procedure"](#).

### 5.CHECK FUEL INJECTOR

Check the fuel injector. Refer to [EC-467, "Component Function Check"](#).

#### Is the inspection result normal?

- YES >> GO TO 6.  
NO >> Perform [EC-467, "Diagnosis Procedure"](#).

### 6.CHECK FUNCTION OF IGNITION COIL-1

#### **CAUTION:**

**Do the following procedure in the place where ventilation is good without the combustible.**

1. Turn ignition switch OFF.
2. Remove fuel pump fuse in IPDM E/R to release fuel pressure.

#### **NOTE:**

Do not use CONSULT to release fuel pressure, or fuel pressure applies again during the following procedure.

3. Start engine.
4. After engine stalls, crank it two or three times to release all fuel pressure.
5. Turn ignition switch OFF.
6. Remove all ignition coil harness connectors to avoid the electrical discharge from the ignition coils.
7. Remove ignition coil and spark plug of the cylinder to be checked.
8. Crank engine for 5 seconds or more to remove combustion gas in the cylinder.
9. Connect spark plug and harness connector to ignition coil.

# P0420 THREE WAY CATALYST FUNCTION

[QR25DE]

## < DTC/CIRCUIT DIAGNOSIS >

10. Fix ignition coil using a rope etc. with gap of 13 - 17 mm (0.52 - 0.66 in) between the edge of the spark plug and grounded metal portion as shown in the figure.
11. Crank engine for about 3 seconds, and check whether spark is generated between the spark plug and the grounded metal portion.

**Spark should be generated.**

### CAUTION:

- Do not approach to the spark plug and the ignition coil within 50 cm (19.7 in). Be careful not to get an electrical shock while checking, because the electrical discharge voltage becomes 20 kV or more.
- It might cause to damage the ignition coil if the gap of more than 17 mm (0.66 in) is taken.

### NOTE:

When the gap is less than 13 mm (0.52 in), the spark might be generated even if the coil is malfunctioning.

Is the inspection result normal?

- YES >> GO TO 10.  
NO >> GO TO 7.

## 7.CHECK FUNCTION OF IGNITION COIL-2

1. Turn ignition switch OFF.
2. Disconnect spark plug and connect a known-good spark plug.
3. Crank engine for about 3 seconds, and recheck whether spark is generated between the spark plug and the grounded metal portion.

**Spark should be generated.**

Is the inspection result normal?

- YES >> GO TO 8.  
NO >> Check ignition coil, power transistor and their circuits. Refer to [EC-473, "Diagnosis Procedure"](#).

## 8.CHECK SPARK PLUG

Check the initial spark plug for fouling, etc. Refer to [EM-19, "Removal and Installation"](#).

Is the inspection result normal?

- YES >> Replace spark plug(s) with standard type one(s). For spark plug type, refer to [EM-120, "General Specification"](#).
- NO >> Repair or clean spark plug. Refer to [EM-19, "Removal and Installation"](#). Then GO TO 9

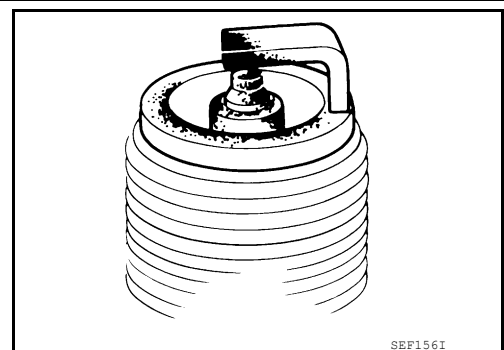

## 9.CHECK FUNCTION OF IGNITION COIL-3

1. Reconnect the initial spark plugs.
2. Crank engine for about 3 seconds, and recheck whether spark is generated between the spark plug and the grounded portion.

**Spark should be generated.**

Is the inspection result normal?

- YES >> INSPECTION END  
NO >> Replace spark plug(s) with standard type one(s). For spark plug type, refer to [EM-120, "General Specification"](#).

## 10.CHECK FUEL INJECTOR

1. Turn ignition switch OFF.

A  
EC  
C  
D  
E  
F  
G  
H  
I  
J  
K  
L  
M  
N  
O  
P

## P0420 THREE WAY CATALYST FUNCTION

[QR25DE]

< DTC/CIRCUIT DIAGNOSIS >

---

2. Remove fuel injector assembly.  
Refer to [EM-45. "Exploded View"](#).  
Keep fuel hose and all fuel injectors connected to fuel tube.
3. Disconnect all ignition coil harness connectors.
4. Reconnect all fuel injector harness connectors disconnected.
5. Turn ignition switch ON.

Does fuel drip from fuel injector?

YES >> GO TO 11.

NO >> Replace the fuel injector(s) from which fuel is dripping. Refer to [EM-45. "Exploded View"](#).

**11**.CHECK INTERMITTENT INCIDENT

---

Refer to [GI-44. "Intermittent Incident"](#).

Is the trouble fixed?

YES >> INSPECTION END

NO >> Replace three way catalyst assembly. Refer to [EM-32. "Exploded View"](#).

# P0441 EVAP CONTROL SYSTEM

< DTC/CIRCUIT DIAGNOSIS >

[QR25DE]

## P0441 EVAP CONTROL SYSTEM

### DTC Description

INFOID:000000011278028

### DTC DETECTION LOGIC

In this evaporative emission (EVAP) control system, purge flow occurs during non-closed throttle conditions. Purge volume is related to air intake volume. Under normal purge conditions (non-closed throttle), the EVAP canister purge volume control solenoid valve is open to admit purge flow. Purge flow exposes the EVAP control system pressure sensor to intake manifold vacuum.

Under normal conditions (non-closed throttle), sensor output voltage indicates if pressure drop and purge flow are adequate. If not, a malfunction is determined.

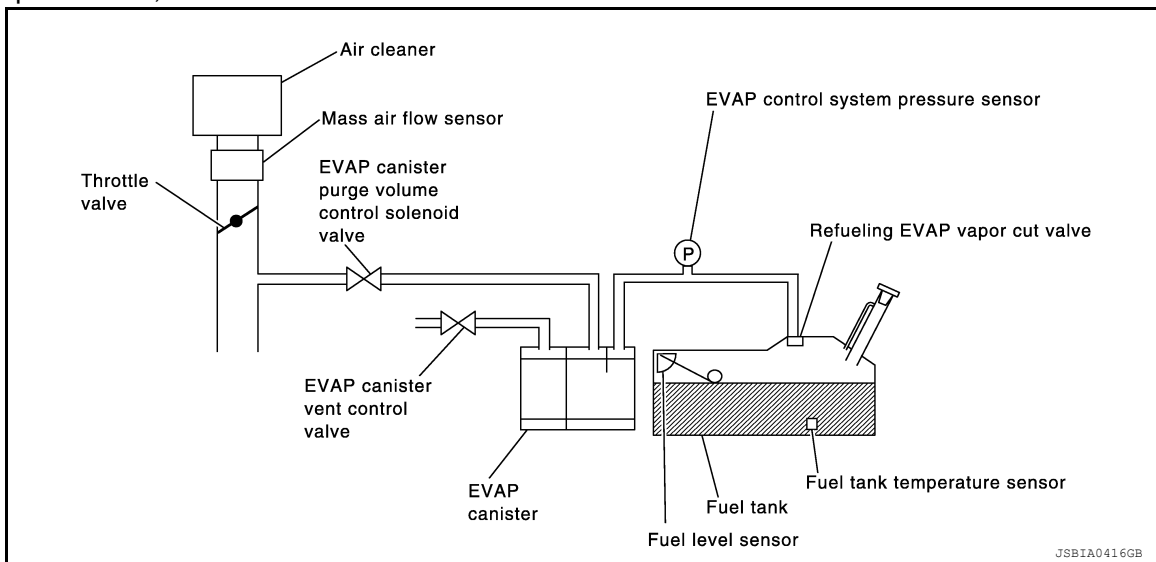

DTC No.	CONSULT screen terms (Trouble diagnosis content)	DTC detecting condition
P0441	EVAP PURG FLOW/MON (Evaporative emission system incorrect purge flow)	EVAP control system does not operate properly, EVAP control system has a leak between intake manifold and EVAP control system pressure sensor.

### POSSIBLE CAUSE

- EVAP canister purge volume control solenoid valve stuck closed
- EVAP control system pressure sensor and the circuit
- Loose, disconnected or improper connection of rubber tube
- Blocked rubber tube
- Cracked EVAP canister
- EVAP canister purge volume control solenoid valve circuit
- Accelerator pedal position sensor
- Blocked purge port
- EVAP canister vent control valve

### FAIL-SAFE

Not applicable

### DTC CONFIRMATION PROCEDURE

#### 1. CHECK DTC PRIORITY

If DTC P0441 is displayed with DTC P2122, P2123, P2127, P2128 or P2138, first perform the trouble diagnosis for DTC P2122, P2123, P2127, P2128 or P2138.

Is applicable DTC detected?

YES >> Perform diagnosis of applicable. Refer to [EC-96. "DTC Index"](#).

NO >> GO TO 2.

#### 2. PRECONDITIONING

# P0441 EVAP CONTROL SYSTEM

[QR25DE]

## < DTC/CIRCUIT DIAGNOSIS >

If DTC Confirmation Procedure has been previously conducted, always perform the following procedure before conducting the next test.

1. Turn ignition switch OFF and wait at least 10 seconds.
2. Turn ignition switch ON.
3. Turn ignition switch OFF and wait at least 10 seconds.

### Will CONSULT be used?

- YES >> GO TO 3.  
NO >> GO TO 6.

## 3.PERFORM DTC CONFIRMATION PROCEDURE-1

### ⓈWITH CONSULT

#### TESTING CONDITION:

**Always perform test at a temperature of 5°C (41°F) or more.**

1. Start engine and warm it up to normal operating temperature.
2. Turn ignition switch OFF and wait at least 10 seconds.
3. Turn ignition switch ON.
4. Turn ignition switch OFF and wait at least 10 seconds.
5. Start engine and let it idle for at least 70 seconds.
6. Select "PURG FLOW P0441" of "EVAPORATIVE SYSTEM" in "DTC WORK SUPPORT" mode of "ENGINE" using CONSULT.
7. Touch "START".

### Is "COMPLETED" displayed on CONSULT screen?

- YES >> GO TO 5.  
NO >> GO TO 4.

## 4.PERFORM DTC CONFIRMATION PROCEDURE-2

When the following conditions are met, "TESTING" will be displayed on the CONSULT screen. Maintain the conditions continuously until "TESTING" changes to "COMPLETED". (It will take at least 35 seconds.)

Selector lever	Suitable position
VHCL SPEED SE	32 - 120 km/h (20 - 75 MPH)
ENG SPEED	500 - 3,800 rpm
B/FUEL SCHDL	1.0 - 10.0 msec
COOLAN TEMP/S	More than 0°C (32°F)

### CAUTION:

**Always drive vehicle at a safe speed.**

#### NOTE:

**If "TESTING" does not change for a long time, retry from step 2.**

### Is "COMPLETED" displayed on CONSULT screen?

- YES >> GO TO 5.  
NO >> Perform DTC CONFIRMATION PROCEDURE again. GO TO 2.

## 5.PERFORM DTC CONFIRMATION PROCEDURE-3

Touch "SELF-DIAG RESULTS".

### Which is displayed on CONSULT screen?

- OK >> INSPECTION END  
NG >> Proceed to [EC-311. "Diagnosis Procedure"](#).

## 6.PERFORM COMPONENT FUNCTION CHECK

1. Lift up drive wheels.
2. Start engine (VDC switch OFF) and warm it up to normal operating temperature.
3. Turn ignition switch OFF and wait at least 10 seconds.
4. Start engine and wait at least 70 seconds.
5. Set voltmeter probes to ECM harness connector terminals as per the following.

# P0441 EVAP CONTROL SYSTEM

< DTC/CIRCUIT DIAGNOSIS >

[QR25DE]

ECM		
Connector	+	-
	Terminal	
E16	114	124

- Check EVAP control system pressure sensor value at idle speed and note it.
- Establish and maintain the following conditions for at least 1 minute.

Air conditioner switch	ON
Headlamp switch	ON
Rear window defogger switch	ON
Engine speed	Approx. 3,000 rpm
Gear position	Any position other than P, N or R

- Verify that EVAP control system pressure sensor value stays 0.1 V less than the value at idle speed (measured at step 6) for at least 1 second.

Is the inspection result normal?

- YES >> INSPECTION END  
 NO >> Proceed to [EC-311, "Diagnosis Procedure"](#).

## Diagnosis Procedure

INFOID:0000000011278029

### 1.CHECK DTC PRIORITY

If DTC P0441 is displayed with DTC P2122, P2123, P2127, P2128 or P2138, first perform the trouble diagnosis for DTC P2122, P2123, P2127, P2128 or P2138.

Is applicable DTC detected?

- YES >> Perform diagnosis of applicable. Refer to [EC-96, "DTC Index"](#).  
 NO >> GO TO 2.

### 2.CHECK EVAP CANISTER

- Turn ignition switch OFF.
- Check EVAP canister for cracks.

Is the inspection result normal?

- YES-1 >> With CONSULT: GO TO 3.  
 YES-2 >> Without CONSULT: GO TO 4.  
 NO >> Replace EVAP canister. Refer to [FL-19, "Removal and Installation"](#).

### 3.CHECK PURGE FLOW

 WITH CONSULT

- Disconnect vacuum hose connected to EVAP canister purge volume control solenoid valve at EVAP service port.
- Start engine and let it idle.
- Select "PURG VOL CONT/V" in "ACTIVE TEST" mode of "ENGINE" using CONSULT.
- Touch "Qd" and "Qu" on CONSULT screen to adjust "PURG VOL CONT/V" opening and check vacuum existence.

PURG VOL CONT/V	Vacuum
100%	Existed
0%	Not existed

Is the inspection result normal?

- YES >> GO TO 8.  
 NO >> GO TO 5.

### 4.CHECK PURGE FLOW

# P0441 EVAP CONTROL SYSTEM

[QR25DE]

< DTC/CIRCUIT DIAGNOSIS >

## ⊗ WITHOUT CONSULT

1. Start engine and warm it up to normal operating temperature.
2. Stop engine.
3. Disconnect vacuum hose connected to EVAP canister purge volume control solenoid valve at EVAP service port and install vacuum gauge. For the location of EVAP service port, refer to [EC-55. "EVAPORATIVE EMISSION SYSTEM : System Description"](#).
4. Start engine and let it idle.  
**Never depress accelerator pedal even slightly.**
5. Check vacuum gauge indication before 60 seconds pass after starting engine.

**Vacuum should not exist.**

6. Rev engine up to 2,000 rpm after 100 seconds pass after starting engine.

**Vacuum should exist.**

Is the inspection result normal?

- YES >> GO TO 8.  
NO >> GO TO 5.

## 5. CHECK EVAP PURGE LINE

1. Turn ignition switch OFF.
2. Check EVAP purge line for improper connection or disconnection.  
Refer to [EC-55. "EVAPORATIVE EMISSION SYSTEM : System Description"](#).

Is the inspection result normal?

- YES >> GO TO 6.  
NO >> Repair EVAP purge line.

## 6. CHECK EVAP PURGE HOSE AND PURGE PORT

1. Disconnect purge hoses connected to EVAP service port (A) and EVAP canister purge volume control solenoid valve (B).
2. Blow air into each hose and EVAP purge port (C).

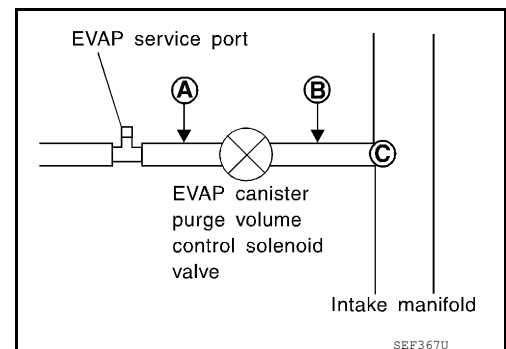

3. Check that air flows freely.

Is the inspection result normal?

- YES-1 >> With CONSULT: GO TO 7.  
YES-2 >> Without CONSULT: GO TO 8.  
NO >> Repair or clean hoses and/or purge port.

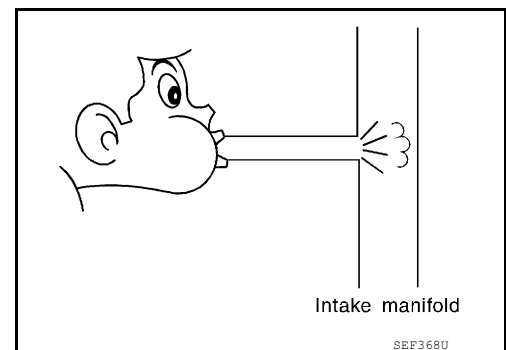

## 7. CHECK EVAP CANISTER PURGE VOLUME CONTROL SOLENOID VALVE

### Ⓟ WITH CONSULT

1. Start engine.
2. Perform "PURG VOL CONT/V" in "ACTIVE TEST" mode of "ENGINE" using CONSULT. Check that engine speed varies according to the valve opening.

Does engine speed vary according to the valve opening?



## P0441 EVAP CONTROL SYSTEM

[QR25DE]

< DTC/CIRCUIT DIAGNOSIS >

- YES >> GO TO 9.  
NO >> GO TO 8.

### 8.CHECK EVAP CANISTER PURGE VOLUME CONTROL SOLENOID VALVE

Check the EVAP canister purge volume control solenoid valve. Refer to [EC-318, "Component Inspection"](#).

Is the inspection result normal?

- YES >> GO TO 9.  
NO >> Replace EVAP canister purge volume control solenoid valve. Refer to [EC-14, "Component Parts Location"](#).

### 9.CHECK EVAP CONTROL SYSTEM PRESSURE SENSOR CONNECTOR

1. Disconnect EVAP control system pressure sensor harness connector.
2. Check that water is not inside connectors.

Is the inspection result normal?

- YES >> GO TO 10.  
NO >> Replace EVAP control system pressure sensor. Refer to [FL-22, "Removal and Installation"](#).

### 10.CHECK EVAP CONTROL SYSTEM PRESSURE SENSOR FUNCTION

Refer to [EC-334, "DTC Description"](#) for DTC P0452, [EC-337, "DTC Description"](#) for DTC P0453.

Is the inspection result normal?

- YES >> GO TO 11.  
NO >> Replace EVAP control system pressure sensor. Refer to [FL-22, "Removal and Installation"](#).

### 11.CHECK RUBBER TUBE FOR CLOGGING

1. Disconnect rubber tube connected to EVAP canister vent control valve.
2. Check the rubber tube for clogging.

Is the inspection result normal?

- YES >> GO TO 12.  
NO >> Clean the rubber tube using an air blower.

### 12.CHECK EVAP CANISTER VENT CONTROL VALVE

Check the EVAP canister vent control valve. Refer to [EC-324, "Component Inspection"](#).

Is the inspection result normal?

- YES >> GO TO 13.  
NO >> Replace EVAP canister vent control valve. Refer to [FL-21, "Removal and Installation"](#).

### 13.CHECK EVAP PURGE LINE

Inspect EVAP purge line (pipe and rubber tube). Check for evidence of leaks.

Refer to [EC-499, "Inspection"](#).

Is the inspection result normal?

- YES >> GO TO 14.  
NO >> Repair or replace malfunctioning part.

### 14.CLEAN EVAP PURGE LINE

Clean EVAP purge line (pipe and rubber tube) using air blower.

>> GO TO 15.

### 15.CHECK INTERMITTENT INCIDENT

Perform [GI-44, "Intermittent Incident"](#).

>> INSPECTION END

# P0443 EVAP CANISTER PURGE VOLUME CONTROL SOLENOID VALVE

< DTC/CIRCUIT DIAGNOSIS >

[QR25DE]

## P0443 EVAP CANISTER PURGE VOLUME CONTROL SOLENOID VALVE

### DTC Description

INFOID:000000011278030

### DTC DETECTION LOGIC

DTC No.	CONSULT screen terms (Trouble diagnosis content)	DTC detecting condition	
P0443	PURG VOLUME CONT/V (Evaporative emission system purge control valve circuit)	A	The canister purge flow is detected during the vehicle is stopped while the engine is running, even when EVAP canister purge volume control solenoid valve is completely closed.
		B	The canister purge flow is detected during the specified driving conditions, even when EVAP canister purge volume control solenoid valve is completely closed.

### POSSIBLE CAUSE

- EVAP control system pressure sensor
- EVAP canister purge volume control solenoid valve (The valve is stuck open.)
- EVAP canister vent control valve
- EVAP canister
- Hoses (Hoses are connected incorrectly or clogged.)

### FAIL-SAFE

Not applicable

### DTC CONFIRMATION PROCEDURE

#### 1. PRECONDITIONING

If DTC Confirmation Procedure has been previously conducted, always perform the following procedure before conducting the next test.

1. Turn ignition switch OFF and wait at least 10 seconds.
2. Turn ignition switch ON.
3. Turn ignition switch OFF and wait at least 10 seconds.

#### TESTING CONDITION:

- **Perform DTC CONFIRMATION PROCEDURE when the fuel is between 1/4 and 3/4 full, and vehicle is placed on flat level surface.**
- **Always perform test at a temperature of 5 to 60°C (41 to 140°F).**
- **Cool the vehicle so that engine coolant temperature becomes same level as ambient temperature.**

#### Do you have CONSULT

- YES >> GO TO 2.  
NO >> GO TO 4.

#### 2. PERFORM DTC CONFIRMATION PROCEDURE A

##### With CONSULT

1. Turn ignition switch ON.
2. Select "DATA MONITOR" mode of "ENGINE" using CONSULT.
3. Check that the following condition are met.  
FUEL T/TMP SE: 0 - 35°C (32 - 95°F)
4. Start engine and wait at least 60 seconds.
5. Check 1st trip DTC.

#### Is 1st trip DTC detected?

- YES >> Proceed to [EC-315. "Diagnosis Procedure"](#).  
NO >> GO TO 3.

#### 3. PERFORM DTC CONFIRMATION PROCEDURE B

##### With CONSULT

1. Start engine and warm it up to normal operating temperature.
2. Turn ignition switch OFF and wait at least 10 seconds.
3. Turn ignition switch ON.

# P0443 EVAP CANISTER PURGE VOLUME CONTROL SOLENOID VALVE

< DTC/CIRCUIT DIAGNOSIS >

[QR25DE]

4. Select "PURG VOL CN/V P1444" of "EVAPORATIVE SYSTEM" in "DTC WORK SUPPORT" mode of "ENGINE" using CONSULT.
5. Touch "START".
6. Start engine and let it idle until "TESTING" on CONSULT changes to "COMPLETED". (It will take approximately 10 seconds.)  
**If "TESTING" is not displayed after 5 minutes, retry from step 2.**
7. Touch "SELF-DIAG RESULT".

Which is displayed on CONSULT?

- OK >> INSPECTION END  
NG >> Proceed to [EC-315. "Diagnosis Procedure"](#).

## 4.PERFORM DTC CONFIRMATION PROCEDURE A

 With GST

1. Turn ignition switch ON.
2. Check the voltage between ECM harness connector and ground.

+		-	Voltage
ECM			
Connector	Terminal		
E16	125	Ground	3.1 - 4.0 V

3. Start engine and wait at least 60 seconds.
4. Check 1st trip DTC.

Is 1st trip DTC detected?

- YES >> Proceed to [EC-315. "Diagnosis Procedure"](#).  
NO >> GO TO 5.

## 5.PERFORM DTC CONFIRMATION PROCEDURE

 With GST

1. Start engine and warm it up to normal operating temperature.
2. Turn ignition switch OFF and wait at least 10 seconds.
3. Start engine and let it idle for at least 20 seconds.
4. Check 1st trip DTC.

Is 1st trip DTC detected?

- YES >> Proceed to [EC-315. "Diagnosis Procedure"](#).  
NO >> INSPECTION END

## Diagnosis Procedure

INFOID:0000000011278031

### 1.CHECK EVAP CANISTER PURGE VOLUME CONTROL SOLENOID VALVE POWER SUPPLY

1. Turn ignition switch OFF.
2. Disconnect EVAP canister purge volume control solenoid valve harness connector.
3. Turn ignition switch ON.
4. Check the voltage between EVAP canister purge volume control solenoid valve harness connector and ground.

+		-	Voltage
EVAP canister purge volume control solenoid valve			
Connector	Terminal		
F16	2	Ground	Battery voltage

Is the inspection result normal?

- YES >> GO TO 3.  
NO >> GO TO 2.

### 2.CHECK EVAP CANISTER PURGE VOLUME CONTROL SOLENOID VALVE POWER SUPPLY CIRCUIT

# P0443 EVAP CANISTER PURGE VOLUME CONTROL SOLENOID VALVE

[QR25DE]

## < DTC/CIRCUIT DIAGNOSIS >

1. Turn ignition switch OFF.
2. Disconnect IPDM E/R harness connector.
3. Check the continuity between EVAP canister purge volume control solenoid valve harness connector and IPDM E/R harness connector.

+		-		Continuity
EVAP canister purge volume control solenoid valve		IPDM E/R		
Connector	Terminal	Connector	Terminal	
F16	2	F35	73	Existed

4. Also check harness for short to ground.

### Is the inspection result normal?

YES >> Perform the trouble diagnosis for power supply circuit.

NO >> Repair or replace error-detected parts.

## 3. CHECK EVAP CANISTER PURGE VOLUME CONTROL SOLENOID VALVE GROUND CIRCUIT

1. Turn ignition switch OFF.
2. Disconnect ECM harness connector.
3. Check the continuity between EVAP canister purge volume control solenoid valve harness connector and ECM harness connector.

+		-		Continuity
EVAP canister purge volume control solenoid valve		ECM		
Connector	Terminal	Connector	Terminal	
F16	1	F51	17	Existed

4. Also check harness for short to power.

### Is the inspection result normal?

YES >> GO TO 4.

NO >> Repair or replace error-detected parts.

## 4. CHECK EVAP CONTROL SYSTEM PRESSURE SENSOR CONNECTOR

1. Disconnect EVAP control system pressure sensor harness connector.
2. Check connectors for water.

**Water should not exist.**

### Is the inspection result normal?

YES >> GO TO 5.

NO >> Replace EVAP control system pressure sensor. Refer to [FL-22. "Removal and Installation"](#).

## 5. CHECK EVAP CONTROL SYSTEM PRESSURE SENSOR

Check the EVAP control system pressure sensor. Refer to [EC-318. "Component Inspection"](#).

### Is the inspection result normal?

YES-1 >> With CONSULT: GO TO 6.

YES-2 >> Without CONSULT: GO TO 7.

NO >> Replace EVAP control system pressure sensor. Refer to [FL-22. "Removal and Installation"](#).

## 6. CHECK EVAP CANISTER PURGE VOLUME CONTROL SOLENOID VALVE

### Ⓜ With CONSULT

1. Turn ignition switch OFF.
2. Reconnect harness connectors disconnected.
3. Start engine.
4. Perform "PURG VOL CONT/V" in "ACTIVE TEST" mode of "ENGINE" using CONSULT. Check that engine speed varies according to the valve opening.

### Is the inspection result normal?

# P0443 EVAP CANISTER PURGE VOLUME CONTROL SOLENOID VALVE

< DTC/CIRCUIT DIAGNOSIS >

[QR25DE]

- YES >> GO TO 8.
- NO >> GO TO 7.

## 7. CHECK EVAP CANISTER PURGE VOLUME CONTROL SOLENOID VALVE

Check the EVAP canister purge volume control solenoid valve. Refer to [EC-318, "Component Inspection"](#).

Is the inspection result normal?

- YES >> GO TO 8.
- NO >> Replace EVAP canister purge volume control solenoid valve. Refer to [EC-14, "Component Parts Location"](#).

## 8. CHECK RUBBER TUBE FOR CLOGGING

1. Disconnect rubber tube connected to EVAP canister vent control valve.
2. Check the rubber tube for clogging.

Is the inspection result normal?

- YES >> GO TO 9.
- NO >> Clean the rubber tube using an air blower.

## 9. CHECK EVAP CANISTER VENT CONTROL VALVE

Check the EVAP canister vent control valve. Refer to [EC-324, "Component Inspection"](#).

Is the inspection result normal?

- YES >> GO TO 10.
- NO >> Replace EVAP canister vent control valve. Refer to [FL-21, "Removal and Installation"](#).

## 10. CHECK IF EVAP CANISTER IS SATURATED WITH WATER

1. Remove EVAP canister with EVAP canister vent control valve and EVAP control system pressure sensor attached.
2. Check if water will drain from EVAP canister.

Does water drain from the EVAP canister?

- YES >> GO TO 11.
- NO >> GO TO 13.

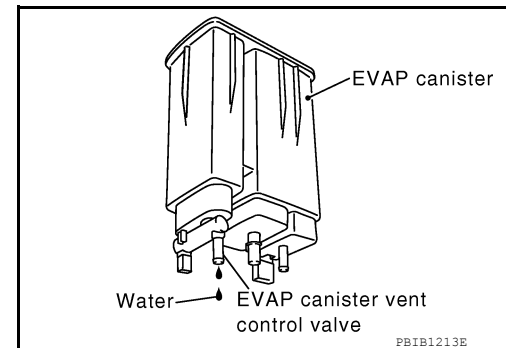

## 11. CHECK EVAP CANISTER

Weigh the EVAP canister with the EVAP canister vent control valve and EVAP control system pressure sensor attached.

**The weight should be less than 2.1 kg (4.6 lb).**

Is the inspection result normal?

- YES >> GO TO 13.
- NO >> GO TO 12.

## 12. DETECT MALFUNCTIONING PART

Check the following.

- EVAP canister for damage
- EVAP hose between EVAP canister and vehicle frame for clogging or poor connection

>> Repair hose or replace EVAP canister. Refer to [FL-19, "Removal and Installation"](#).

## 13. CHECK INTERMITTENT INCIDENT

Refer to [GI-44, "Intermittent Incident"](#).

>> INSPECTION END

# P0443 EVAP CANISTER PURGE VOLUME CONTROL SOLENOID VALVE

< DTC/CIRCUIT DIAGNOSIS >

[QR25DE]

## Component Inspection

INFOID:000000011278032

### 1. CHECK EVAP CANISTER PURGE VOLUME CONTROL SOLENOID VALVE

#### ④ With CONSULT

1. Turn ignition switch OFF.
2. Reconnect all harness connectors disconnected.
3. Disconnect EVAP purge hoses connected to EVAP canister purge volume control solenoid valve.
4. Start engine.
5. Select "PURG VOL CONT/V" in "ACTIVE TEST" mode of "ENGINE" using CONSULT.
6. Touch "Qd" and "Qu" on CONSULT screen to adjust "PURG VOL C/V" opening and check air passage continuity of EVAP canister purge volume control solenoid valve as per the following conditions.

Condition (PURG VOL C/V value)	Air passage continuity between (A) and (B)
100%	Existed
0%	Not existed

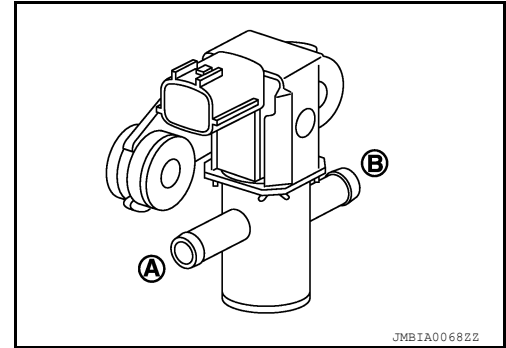

#### ⊗ Without CONSULT

1. Turn ignition switch OFF.
2. Disconnect EVAP canister purge volume control solenoid valve harness connector.
3. Disconnect EVAP purge hoses connected to EVAP canister purge volume control solenoid valve.
4. Check air passage continuity of EVAP canister purge volume control solenoid valve as per the following conditions.

Condition	Air passage continuity between (A) and (B)
12 V direct current supply between terminals 1 and 2	Existed
No supply	Not existed

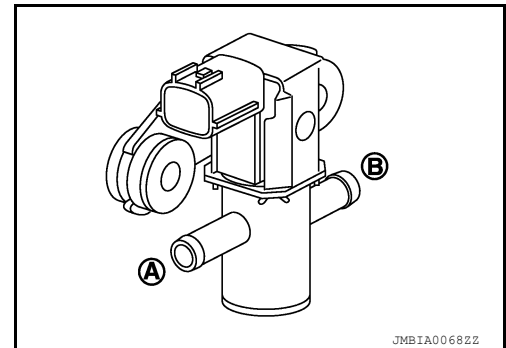

#### Is the inspection result normal?

YES >> INSPECTION END

NO >> Replace EVAP canister purge volume control solenoid valve. Refer to [EC-14](#), "[Component Parts Location](#)".

# P0444, P0445 EVAP CANISTER PURGE VOLUME CONTROL SOLENOID VALVE

< DTC/CIRCUIT DIAGNOSIS >

[QR25DE]

## P0444, P0445 EVAP CANISTER PURGE VOLUME CONTROL SOLENOID VALVE

### DTC Description

INFOID:0000000011278033

### DTC DETECTION LOGIC

DTC No.	CONSULT screen terms (Trouble diagnosis content)	DTC detecting condition
P0444	PURG VOLUME CONT/V (Evaporative emission system purge control valve circuit open)	An excessively low voltage signal is sent to ECM through the EVAP canister purge volume control solenoid valve.
P0445	PURG VOLUME CONT/V (Evaporative emission system purge control valve circuit shorted)	An excessively high voltage signal is sent to ECM through the valve

### POSSIBLE CAUSE

#### DTC P0444

- Harness or connectors (EVAP canister purge volume control solenoid valve circuit is open or shorted.)
- EVAP canister purge volume control solenoid valve

#### DTC P0445

- Harness or connectors (EVAP canister purge volume control solenoid valve circuit is shorted.)
- EVAP canister purge volume control solenoid valve

### FAIL-SAFE

Not applicable

### DTC CONFIRMATION PROCEDURE

#### 1.CONDITIONING

If DTC Confirmation Procedure has been previously conducted, always perform the following procedure before conducting the next test.

1. Turn ignition switch OFF and wait at least 10 seconds.
2. Turn ignition switch ON.
3. Turn ignition switch OFF and wait at least 10 seconds.

#### TESTING CONDITION:

**Before performing the following procedure, confirm battery voltage is more than 11 V at idle.**

>> GO TO 2.

#### 2.PERFORM DTC CONFIRMATION PROCEDURE

1. Start engine and let it idle for at least 13 seconds.
2. Check 1st trip DTC.

#### Is 1st trip DTC detected?

- YES >> Proceed to [EC-319, "Diagnosis Procedure"](#).
- NO >> INSPECTION END

### Diagnosis Procedure

INFOID:0000000011278034

#### 1.CHECK EVAP CANISTER PURGE VOLUME CONTROL SOLENOID VALVE POWER SUPPLY

1. Turn ignition switch OFF.
2. Disconnect EVAP canister purge volume control solenoid valve harness connector.
3. Turn ignition switch ON.
4. Check the voltage between EVAP canister purge volume control solenoid valve harness connector and ground.

# P0444, P0445 EVAP CANISTER PURGE VOLUME CONTROL SOLENOID VALVE

< DTC/CIRCUIT DIAGNOSIS >

[QR25DE]

+		-	Voltage
EVAP canister purge volume control solenoid valve			
Connector	Terminal		
F16	2	Ground	Battery voltage

Is the inspection result normal?

- YES >> GO TO 3.
- NO >> GO TO 2.

## 2. CHECK EVAP CANISTER PURGE VOLUME CONTROL SOLENOID VALVE POWER SUPPLY CIRCUIT

1. Turn ignition switch OFF.
2. Disconnect IPDM E/R harness connector.
3. Check the continuity between EVAP canister purge volume control solenoid valve harness connector and IPDM E/R harness connector.

+		-		Continuity
EVAP canister purge volume control solenoid valve		IPDM E/R		
Connector	Terminal	Connector	Terminal	
F16	2	F35	73	Existed

4. Also check harness for short to ground.

Is the inspection result normal?

- YES >> Perform the trouble diagnosis for power supply circuit.
- NO >> Repair or replace error-detected parts.

## 3. CHECK EVAP CANISTER PURGE VOLUME CONTROL SOLENOID VALVE GROUND CIRCUIT

1. Turn ignition switch OFF.
2. Disconnect ECM harness connector.
3. Check the continuity between EVAP canister purge volume control solenoid valve harness connector and ECM harness connector.

+		-		Continuity
EVAP canister purge volume control solenoid valve		ECM		
Connector	Terminal	Connector	Terminal	
F16	1	F51	17	Existed

4. Also check harness for short to power.

Is the inspection result normal?

- YES-1 >> With CONSULT: GO TO 4.
- YES-2 >> Without CONSULT: GO TO 5.
- NO >> Repair or replace error-detected parts.

## 4. CHECK EVAP CANISTER PURGE VOLUME CONTROL SOLENOID VALVE OPERATION

Ⓟ With CONSULT

1. Reconnect all harness connectors disconnected.
2. Start engine.
3. Perform "PURG VOL CONT/V" in "ACTIVE TEST" mode of "ENGINE" using CONSULT.
4. Check that engine speed varies according to the valve opening.

Does engine speed vary according to the valve opening?

- YES >> GO TO 6.
- NO >> GO TO 5.

## 5. CHECK EVAP CANISTER PURGE VOLUME CONTROL SOLENOID VALVE



# P0444, P0445 EVAP CANISTER PURGE VOLUME CONTROL SOLENOID VALVE

< DTC/CIRCUIT DIAGNOSIS >

[QR25DE]

Check the EVAP canister purge volume control solenoid valve. Refer to [EC-318. "Component Inspection"](#).

Is the inspection result normal?

YES >> GO TO 6.

NO >> Replace EVAP canister purge volume control solenoid valve. Refer to [EC-14. "Component Parts Location"](#).

## 6. CHECK INTERMITTENT INCIDENT

Refer to [GI-44. "Intermittent Incident"](#).

>> INSPECTION END

## Component Inspection

INFOID:000000011278035

### 1. CHECK EVAP CANISTER PURGE VOLUME CONTROL SOLENOID VALVE

With CONSULT

1. Turn ignition switch OFF.
2. Reconnect all harness connectors disconnected.
3. Disconnect EVAP purge hoses connected to EVAP canister purge volume control solenoid valve.
4. Start engine.
5. Select "PURG VOL CONT/V" in "ACTIVE TEST" mode of "ENGINE" using CONSULT.
6. Touch "Qd" and "Qu" on CONSULT screen to adjust "PURG VOL C/V" opening and check air passage continuity of EVAP canister purge volume control solenoid valve as per the following conditions.

Condition (PURG VOL C/V value)	Air passage continuity between (A) and (B)
100%	Existed
0%	Not existed

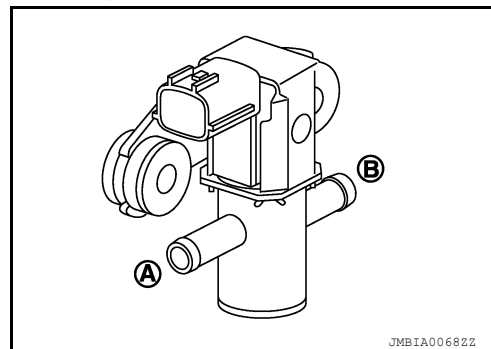

Without CONSULT

1. Turn ignition switch OFF.
2. Disconnect EVAP canister purge volume control solenoid valve harness connector.
3. Disconnect EVAP purge hoses connected to EVAP canister purge volume control solenoid valve.
4. Check air passage continuity of EVAP canister purge volume control solenoid valve as per the following conditions.

Condition	Air passage continuity between (A) and (B)
12 V direct current supply between terminals 1 and 2	Existed
No supply	Not existed

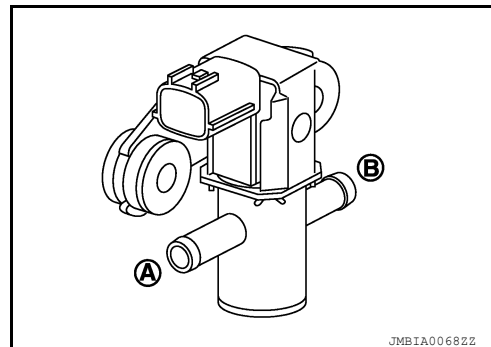

Is the inspection result normal?

YES >> INSPECTION END

NO >> Replace EVAP canister purge volume control solenoid valve. Refer to [EC-14. "Component Parts Location"](#).

# P0447 EVAP CANISTER VENT CONTROL VALVE

< DTC/CIRCUIT DIAGNOSIS >

[QR25DE]

## P0447 EVAP CANISTER VENT CONTROL VALVE

### DTC Description

INFOID:000000011278036

### DTC DETECTION LOGIC

DTC No.	CONSULT screen terms (Trouble diagnosis content)	DTC detecting condition
P0447	VENT CONTROL VALVE (Evaporative emission system vent control circuit open)	An improper voltage signal is sent to ECM through EVAP canister vent control valve.

### POSSIBLE CAUSE

- Harness or connectors (EVAP canister vent control valve circuit is open or shorted.)
- EVAP canister vent control valve

### FAIL-SAFE

Not applicable

### DTC CONFIRMATION PROCEDURE

#### 1. PRECONDITIONING

If DTC Confirmation Procedure has been previously conducted, always perform the following procedure before conducting the next test.

1. Turn ignition switch OFF and wait at least 10 seconds.
2. Turn ignition switch ON.
3. Turn ignition switch OFF and wait at least 10 seconds.

#### TESTING CONDITION:

**Before performing the following procedure, confirm battery voltage is more than 11 V at idle.**

>> GO TO 2.

#### 2. PERFORM DTC CONFIRMATION PROCEDURE

1. Start engine and wait at least 8 seconds.
2. Check 1st trip DTC.

#### Is 1st trip DTC detected?

- YES >> Proceed to [EC-322. "Diagnosis Procedure"](#).  
NO >> INSPECTION END

### Diagnosis Procedure

INFOID:000000011278037

#### 1. INSPECTION START

Do you have CONSULT?

#### Do you have CONSULT?

- YES >> GO TO 2.  
NO >> GO TO 3.

#### 2. CHECK EVAP CANISTER VENT CONTROL VALVE CIRCUIT

##### Ⓟ With CONSULT

1. Turn ignition switch OFF and then turn ON.
2. Select "VENT CONTROL/V" in "ACTIVE TEST" mode of "ENGINE" using CONSULT.
3. Touch "ON/OFF" on CONSULT screen.
4. Check for operating sound of the valve.

**Clicking sound should be heard.**

#### Is the inspection result normal?

- YES >> GO TO 7.  
NO >> GO TO 3.

# P0447 EVAP CANISTER VENT CONTROL VALVE

< DTC/CIRCUIT DIAGNOSIS >

[QR25DE]

## 3. CHECK EVAP CANISTER VENT CONTROL VALVE POWER SUPPLY

1. Turn ignition switch OFF.
2. Disconnect EVAP canister vent control valve harness connector.
3. Turn ignition switch ON.
4. Check the voltage between EVAP canister vent control valve harness connector and ground.

+		-	Voltage
EVAP canister vent control valve			
Connector	Terminal		
B108	1	Ground	Battery voltage

Is the inspection result normal?

YES >> GO TO 5.

NO >> GO TO 4.

## 4. CHECK EVAP CANISTER VENT CONTROL VALVE POWER SUPPLY CIRCUIT

1. Turn ignition switch OFF.
2. Disconnect IPDM E/R harness connector.
3. Check the continuity between EVAP canister vent control valve harness connector and IPDM E/R harness connector.

+		-		Continuity
EVAP canister vent control valve		IPDM E/R		
Connector	Terminal	Connector	Terminal	
B108	1	F35	78	Existed

4. Also check harness for short to ground.

Is the inspection result normal?

YES >> Perform the trouble diagnosis for power supply circuit.

NO >> Repair or replace error-detected parts.

## 5. CHECK EVAP CANISTER VENT CONTROL VALVE OUTPUT SIGNAL CIRCUIT

1. Turn ignition switch OFF.
2. Disconnect ECM harness connector.
3. Check the continuity between EVAP canister vent control valve harness connector and ECM harness connector.

+		-		Continuity
EVAP canister vent control valve		ECM		
Connector	Terminal	Connector	Terminal	
B108	2	E16	97	Existed

4. Also check harness for short to power.

Is the inspection result normal?

YES >> GO TO 6.

NO >> Repair or replace error-detected parts.

## 6. CHECK RUBBER TUBE FOR CLOGGING

1. Disconnect rubber tube connected to EVAP canister vent control valve.
2. Check the rubber tube for clogging.

Is the inspection result normal?

YES >> GO TO 7.

NO >> Clean the rubber tube using an air blower.

# P0447 EVAP CANISTER VENT CONTROL VALVE

< DTC/CIRCUIT DIAGNOSIS >

[QR25DE]

## 7. CHECK EVAP CANISTER VENT CONTROL VALVE

Check the EVAP canister vent control valve. Refer to [EC-324, "Component Inspection"](#).

Is the inspection result normal?

YES >> GO TO 8.

NO >> Replace EVAP canister vent control valve. Refer to [FL-21, "Removal and Installation"](#)

## 8. CHECK INTERMITTENT INCIDENT

Refer to [GI-44, "Intermittent Incident"](#).

>> INSPECTION END

## Component Inspection

INFOID:000000011278038

### 1. CHECK EVAP CANISTER VENT CONTROL VALVE-1

1. Turn ignition switch OFF.
2. Remove EVAP canister vent control valve from EVAP canister.
3. Check portion (A) of EVAP canister vent control valve for being rusted.

Is it rusted?

YES >> Replace EVAP canister vent control valve. Refer to [FL-21, "Removal and Installation"](#).

NO >> GO TO 2.

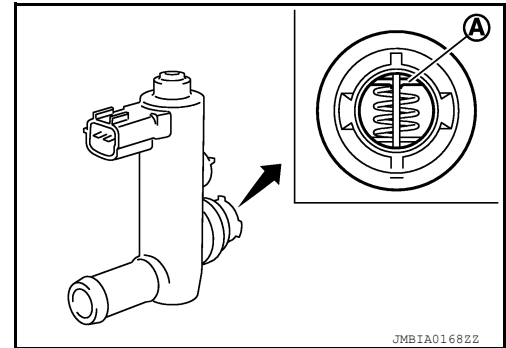

JMBIA01682Z

### 2. CHECK EVAP CANISTER VENT CONTROL VALVE-2

Ⓟ With CONSULT

1. Reconnect harness connectors disconnected.
2. Turn ignition switch ON.
3. Perform "VENT CONTROL/V" in "ACTIVE TEST" mode of "ENGINE" using CONSULT.
4. Check air passage continuity and operation delay time.

**Make sure new O-ring is installed properly.**

Condition (VENT CONT/V)	Air passage continuity between (A) and (B)
ON	Not existed
OFF	Existed

Operation takes less than 1 second.

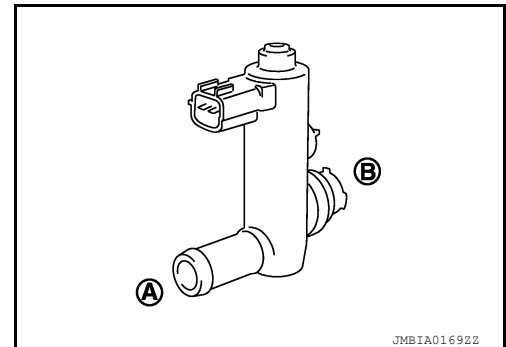

JMBIA01692Z

ⓧ Without CONSULT

Check air passage continuity and operation delay time under the following conditions.

**Make sure new O-ring is installed properly.**

Condition	Air passage continuity between (A) and (B)
12 V direct current supply between terminals 1 and 2	Not existed
OFF	Existed

Operation takes less than 1 second.

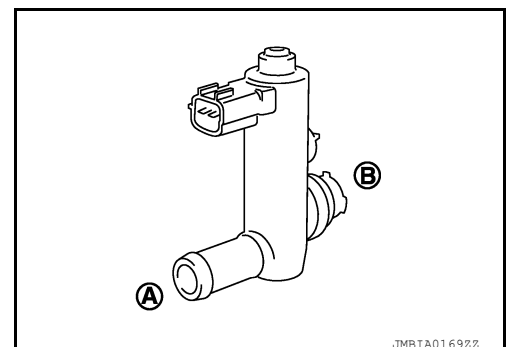

JMBIA01692Z

# P0447 EVAP CANISTER VENT CONTROL VALVE

[QR25DE]

< DTC/CIRCUIT DIAGNOSIS >

Is the inspection result normal?

YES >> GO TO 3.

NO >> Replace EVAP canister vent control valve. Refer to [FL-21. "Removal and Installation"](#).

## 3. CHECK EVAP CANISTER VENT CONTROL VALVE-3

With CONSULT

1. Clean the air passage [portion (A) to (B)] of EVAP canister vent control valve using an air blower.
2. Perform "VENT CONTROL/V" in "ACTIVE TEST" mode of "ENGINE" using CONSULT.
3. Check air passage continuity and operation delay time.  
**Make sure new O-ring is installed properly.**

Condition (VENT CONT/V)	Air passage continuity between (A) and (B)
ON	Not existed
OFF	Existed

Operation takes less than 1 second.

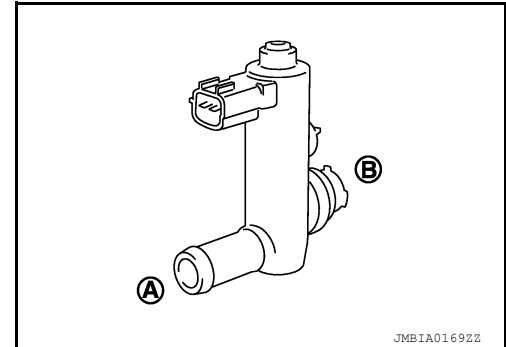

Without CONSULT

1. Clean the air passage [portion (A) to (B)] of EVAP canister vent control valve using an air blower.
2. Check air passage continuity and operation delay time under the following conditions.  
**Make sure new O-ring is installed properly.**

Condition	Air passage continuity between (A) and (B)
12 V direct current supply between terminals 1 and 2	Not existed
OFF	Existed

Operation takes less than 1 second.

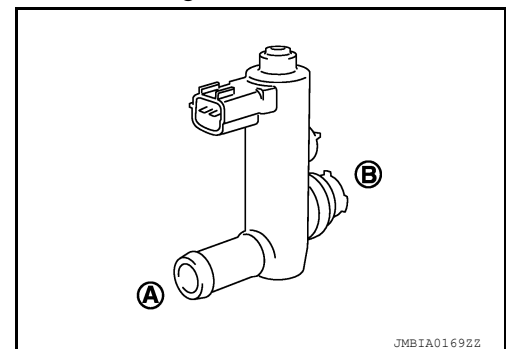

Is the inspection result normal?

YES >> INSPECTION END

NO >> Replace EVAP canister vent control valve. Refer to [FL-21. "Removal and Installation"](#).

# P0448 EVAP CANISTER VENT CONTROL VALVE

< DTC/CIRCUIT DIAGNOSIS >

[QR25DE]

## P0448 EVAP CANISTER VENT CONTROL VALVE

### DTC Description

INFOID:000000011278039

### DTC DETECTION LOGIC

DTC No.	CONSULT screen terms (Trouble diagnosis content)	DTC detecting condition
P0448	VENT CONTROL VALVE (Evaporative emission system vent control circuit shorted)	EVAP canister vent control valve remains closed under specified driving conditions.

### POSSIBLE CAUSE

- EVAP canister vent control valve
- EVAP control system pressure sensor and the circuit
- Blocked rubber tube to EVAP canister vent control valve
- EVAP canister is saturated with water

### FAIL-SAFE

Not applicable

### DTC CONFIRMATION PROCEDURE

#### 1. PRECONDITIONING

If DTC Confirmation Procedure has been previously conducted, always perform the following procedure before conducting the next test.

1. Turn ignition switch OFF and wait at least 10 seconds.
2. Turn ignition switch ON.
3. Turn ignition switch OFF and wait at least 10 seconds.

>> GO TO 2.

#### 2. PERFORM DTC CONFIRMATION PROCEDURE

##### ④ With CONSULT

1. Turn ignition switch ON and wait at least 5 seconds.
2. Turn ignition switch OFF and wait at least 10 seconds.
3. Turn ignition switch ON and select "DATA MONITOR" mode of "ENGINE" using CONSULT.
4. Start engine and let it idle for at least 1 minute.
5. Repeat next procedures three times.
  - Increase the engine speed up to 3,000 to 3,500 rpm and keep it for 2 minutes and 50 seconds to 3 minutes.

##### Never exceed 3 minutes.

- Fully released accelerator pedal and keep engine idle for about 5 seconds.
- 6. Repeat next procedure 20 times.
  - Quickly increase the engine speed up to 4,000 to 4,500 rpm or more and keep it for 25 to 30 seconds.
  - Fully released accelerator pedal and keep engine idle for at least 35 seconds.

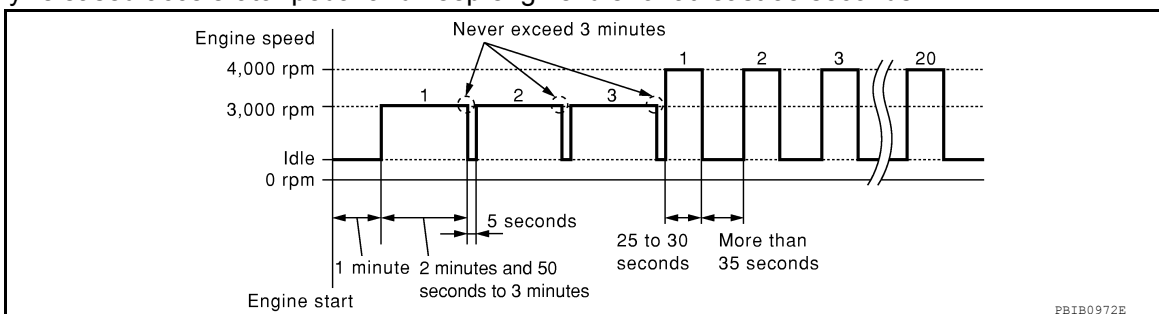

7. Check 1st trip DTC.

##### ④ With GST

Follow the procedure "With CONSULT" above.

Is 1st trip DTC detected?

# P0448 EVAP CANISTER VENT CONTROL VALVE

[QR25DE]

< DTC/CIRCUIT DIAGNOSIS >

- YES >> Proceed to [EC-327, "Diagnosis Procedure"](#).  
NO >> INSPECTION END

## Diagnosis Procedure

INFOID:000000011278040

### 1. CHECK RUBBER TUBE

1. Turn ignition switch OFF.
2. Disconnect rubber tube connected to EVAP canister vent control valve.
3. Check the rubber tube for clogging.

Is the inspection result normal?

- YES >> GO TO 2.  
NO >> Clean rubber tube using an air blower.

### 2. CHECK EVAP CANISTER VENT CONTROL VALVE

Check the EVAP canister vent control valve. Refer to [EC-328, "Component Inspection"](#).

Is the inspection result normal?

- YES >> GO TO 3.  
NO >> Replace EVAP canister vent control valve. Refer to [FL-21, "Removal and Installation"](#).

### 3. CHECK IF EVAP CANISTER IS SATURATED WITH WATER

1. Remove EVAP canister with EVAP canister vent control valve and EVAP control system pressure sensor attached.
2. Check if water will drain from the EVAP canister.

Does water drain from EVAP canister?

- YES >> GO TO 4.  
NO >> GO TO 6.

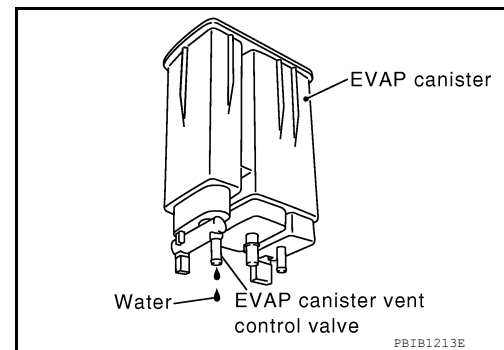

### 4. CHECK EVAP CANISTER

Weigh the EVAP canister with the EVAP canister vent control valve and EVAP control system pressure sensor attached.

**The weight should be less than 2.1 kg (4.6 lb).**

Is the inspection result normal?

- YES >> GO TO 6.  
NO >> GO TO 5.

### 5. DETECT MALFUNCTIONING PART

Check the following.

- EVAP canister for damage
- EVAP hose between EVAP canister and vehicle frame for clogging or poor connection

>> Repair hose or replace EVAP canister. Refer to [FL-19, "Removal and Installation"](#).

### 6. CHECK EVAP CONTROL SYSTEM PRESSURE SENSOR CONNECTOR

1. Disconnect EVAP control system pressure sensor harness connector.
2. Check connectors for water.

**Water should not exist.**

Is the inspection result normal?

- YES >> GO TO 7.  
NO >> Replace EVAP control system pressure sensor. Refer to [FL-22, "Removal and Installation"](#).

# P0448 EVAP CANISTER VENT CONTROL VALVE

< DTC/CIRCUIT DIAGNOSIS >

[QR25DE]

## 7. CHECK EVAP CONTROL SYSTEM PRESSURE SENSOR

Check the EVAP control system pressure sensor. Refer to [EC-333. "Component Inspection"](#).

Is the inspection result normal?

YES >> GO TO 8.

NO >> Replace EVAP control system pressure sensor. Refer to [FL-22. "Removal and Installation"](#).

## 8. CHECK INTERMITTENT INCIDENT

Refer to [GI-44. "Intermittent Incident"](#).

>> INSPECTION END

## Component Inspection

INFOID:000000011278041

### 1. CHECK EVAP CANISTER VENT CONTROL VALVE-1

1. Turn ignition switch OFF.
2. Remove EVAP canister vent control valve from EVAP canister.
3. Check portion (A) of EVAP canister vent control valve for being rusted.

Is it rusted?

YES >> Replace EVAP canister vent control valve. Refer to [FL-21. "Removal and Installation"](#).

NO >> GO TO 2.

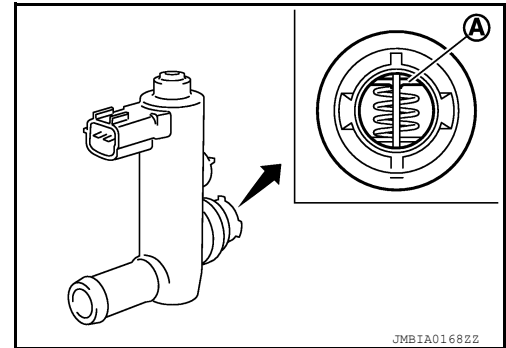

JMBIA01682Z

### 2. CHECK EVAP CANISTER VENT CONTROL VALVE-2

Ⓟ With CONSULT

1. Reconnect harness connectors disconnected.
2. Turn ignition switch ON.
3. Perform "VENT CONTROL/V" in "ACTIVE TEST" mode of "ENGINE" using CONSULT.
4. Check air passage continuity and operation delay time.

**Make sure new O-ring is installed properly.**

Condition (VENT CONT/V)	Air passage continuity between (A) and (B)
ON	Not existed
OFF	Existed

Operation takes less than 1 second.

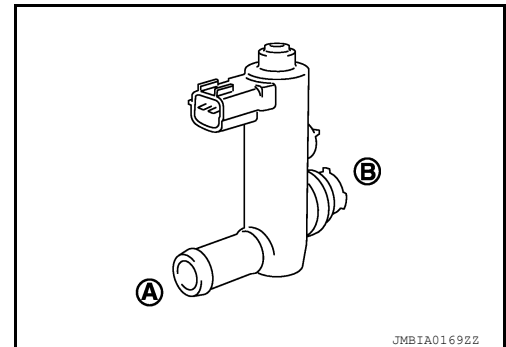

JMBIA01692Z

ⓧ Without CONSULT

Check air passage continuity and operation delay time under the following conditions.

**Make sure new O-ring is installed properly.**

Condition	Air passage continuity between (A) and (B)
12 V direct current supply between terminals 1 and 2	Not existed
OFF	Existed

Operation takes less than 1 second.

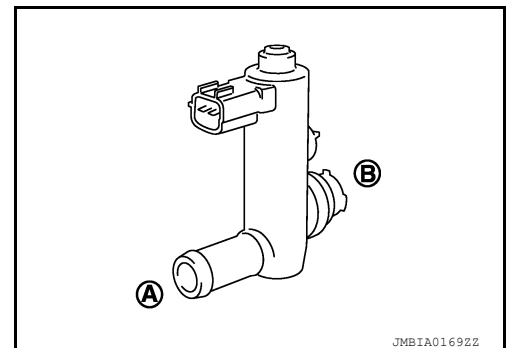

JMBIA01692Z



# P0448 EVAP CANISTER VENT CONTROL VALVE

[QR25DE]

< DTC/CIRCUIT DIAGNOSIS >

Is the inspection result normal?

YES >> GO TO 3.

NO >> Replace EVAP canister vent control valve. Refer to [FL-21. "Removal and Installation"](#).

## 3. CHECK EVAP CANISTER VENT CONTROL VALVE-3

With CONSULT

1. Clean the air passage [portion (A) to (B)] of EVAP canister vent control valve using an air blower.
2. Perform "VENT CONTROL/V" in "ACTIVE TEST" mode of "ENGINE" using CONSULT.
3. Check air passage continuity and operation delay time.  
**Make sure new O-ring is installed properly.**

Condition (VENT CONT/V)	Air passage continuity between (A) and (B)
ON	Not existed
OFF	Existed

Operation takes less than 1 second.

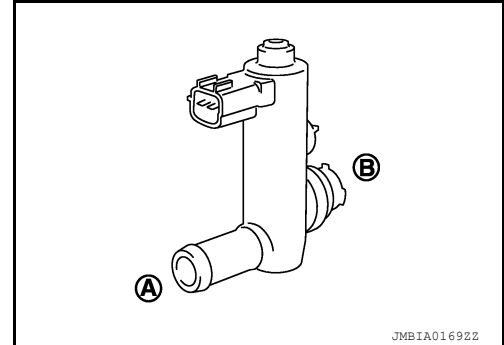

Without CONSULT

1. Clean the air passage [portion (A) to (B)] of EVAP canister vent control valve using an air blower.
2. Check air passage continuity and operation delay time under the following conditions.  
**Make sure new O-ring is installed properly.**

Condition	Air passage continuity between (A) and (B)
12 V direct current supply between terminals 1 and 2	Not existed
OFF	Existed

Operation takes less than 1 second.

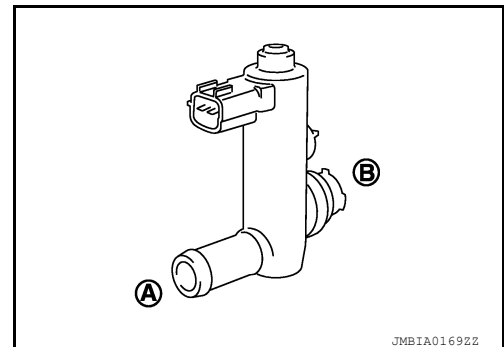

Is the inspection result normal?

YES >> INSPECTION END

NO >> Replace EVAP canister vent control valve. Refer to [FL-21. "Removal and Installation"](#).

# P0451 EVAP CONTROL SYSTEM PRESSURE SENSOR

< DTC/CIRCUIT DIAGNOSIS >

[QR25DE]

## P0451 EVAP CONTROL SYSTEM PRESSURE SENSOR

### DTC Description

INFOID:000000011278042

### DTC DETECTION LOGIC

DTC No.	CONSULT screen terms (Trouble diagnosis content)	DTC detecting condition
P0451	EVAP SYS PRES SEN (Evaporative emission system pressure sensor/switch range/performance)	ECM detects a sloshing signal from the EVAP control system pressure sensor

### POSSIBLE CAUSE

- Harness or connectors (EVAP control system pressure sensor circuit is shorted.)
- EVAP control system pressure sensor

### FAIL-SAFE

Not applicable

### DTC CONFIRMATION PROCEDURE

#### NOTE:

**Never remove fuel filler cap during DTC confirmation procedure.**

#### 1. PRECONDITIONING

If DTC Confirmation Procedure has been previously conducted, always perform the following procedure before conducting the next test.

1. Turn ignition switch OFF and wait at least 10 seconds.
2. Turn ignition switch ON.
3. Turn ignition switch OFF and wait at least 10 seconds.

With CONSULT >> GO TO 2.

Without CONSULT >> GO TO 5.

#### 2. PERFORM DTC CONFIRMATION PROCEDURE-1

With CONSULT

1. Start engine and let it idle for least 40 seconds.

#### NOTE:

**Do not depress accelerator pedal even slightly.**

2. Check 1st trip DTC.

Is 1st trip DTC detected?

YES >> Proceed to [EC-331, "Diagnosis Procedure"](#).

NO >> GO TO 3.

#### 3. PERFORM DTC CONFIRMATION PROCEDURE-2

With CONSULT

1. Select "EVAP DIAG READY" in "DATA MONITOR" mode of "ENGINE".
2. Let it idle until "OFF" of "EVAP DIAG READY" changes to "ON".

#### NOTE:

**It will take at most 2 hours until "OFF" of "EVAP DIAG READY" changes to "ON".**

3. Turn ignition switch OFF and wait at least 90 minutes.

#### NOTE:

**Never turn ignition switch ON during 90 minutes.**

4. Turn ignition switch ON.
5. Select "EVAP LEAK DIAG" in "DATA MONITOR" mode of "ENGINE".
6. Check that "EVAP LEAK DIAG" indication.

Which is displayed on CONSULT?

CMPLT >> GO TO 4.

YET >> 1. Perform DTC CONFIRMATION PROCEDURE again.

2. GO TO 1.

# P0451 EVAP CONTROL SYSTEM PRESSURE SENSOR

< DTC/CIRCUIT DIAGNOSIS >

[QR25DE]

## 4. PERFORM DTC CONFIRMATION PROCEDURE-3

Ⓜ With CONSULT  
Check 1st trip DTC.

Is 1st trip DTC detected?

- YES >> Proceed to [EC-331, "Diagnosis Procedure"](#).
- NO >> INSPECTION END

## 5. PERFORM DTC CONFIRMATION PROCEDURE-4

Ⓜ With GST

1. Start engine and let it idle for least 40 seconds.

**NOTE:**

**Do not depress accelerator pedal even slightly.**

2. Check 1st trip DTC.

Is 1st trip DTC detected?

- YES >> Proceed to [EC-331, "Diagnosis Procedure"](#).
- NO >> GO TO 6.

## 6. PERFORM DTC CONFIRMATION PROCEDURE-5

Ⓜ With GST

1. Let it idle for at least 2 hours.
2. Turn ignition switch OFF and wait at least 90 minutes.

**NOTE:**

**Never turn ignition switch ON during 90 minutes.**

3. Turn ignition switch ON.
4. Check 1st trip DTC.

Is 1st trip DTC detected?

- YES >> Proceed to [EC-331, "Diagnosis Procedure"](#).
- NO >> INSPECTION END

## Diagnosis Procedure

INFOID:0000000011278043

### 1. CHECK EVAP CONTROL SYSTEM PRESSURE SENSOR CONNECTOR FOR WATER

1. Turn ignition switch OFF.
2. Disconnect EVAP control system pressure sensor harness connector.
3. Check sensor harness connector for water.

**Water should not exist.**

Is the inspection result normal?

- YES >> GO TO 2.
- NO >> Repair or replace harness connector.

### 2. CHECK EVAP CONTROL SYSTEM PRESSURE SENSOR POWER SUPPLY

1. Turn ignition switch ON.
2. Check the voltage between EVAP control system pressure sensor harness connector and ground.

+		-	Voltage (Approx.)
Connector	Terminal		
B111	3	Ground	5 V

Is the inspection result normal?

- YES >> GO TO 4.
- NO >> GO TO 3.

### 3. CHECK EVAP CONTROL SYSTEM PRESSURE SENSOR POWER SUPPLY CIRCUIT

# P0451 EVAP CONTROL SYSTEM PRESSURE SENSOR

[QR25DE]

## < DTC/CIRCUIT DIAGNOSIS >

1. Turn ignition switch OFF.
2. Disconnect ECM harness connector.
3. Check the continuity between EVAP control system pressure sensor harness connector and ECM harness connector.

+		-		Continuity
EVAP control system pressure sensor		ECM		
Connector	Terminal	Connector	Terminal	
B111	3	E16	113	Existed

4. Also check harness for short to ground and to power.

### Is the inspection result normal?

YES >> Perform the trouble diagnosis for power supply circuit.

NO >> Repair or replace error-detected parts

## 4. CHECK EVAP CONTROL SYSTEM PRESSURE SENSOR GROUND CIRCUIT

1. Turn ignition switch OFF.
2. Disconnect ECM harness connector.
3. Check the continuity between EVAP control system pressure sensor harness connector and ECM harness connector.

+		-		Continuity
EVAP control system pressure sensor		ECM		
Connector	Terminal	Connector	Terminal	
B111	1	E16	124	Existed

4. Also check harness for short to power.

### Is the inspection result normal?

YES >> GO TO 5.

NO >> Repair or replace error-detected parts.

## 5. CHECK EVAP CONTROL SYSTEM PRESSURE SENSOR SIGNAL CIRCUIT

1. Check the continuity between EVAP control system pressure sensor harness connector and ECM harness connector.

+		-		Continuity
EVAP control system pressure sensor		ECM		
Connector	Terminal	Connector	Terminal	
B111	2	E16	114	Existed

2. Also check harness for short to ground and to power.

### Is the inspection result normal?

YES >> GO TO 6.

NO >> Repair or replace error-detected parts.

## 6. CHECK EVAP CONTROL SYSTEM PRESSURE SENSOR

Check the EVAP control system pressure sensor. Refer to [EC-333, "Component Inspection"](#).

### Is the inspection result normal?

YES >> GO TO 7.

NO >> Replace EVAP control system pressure sensor. Refer to [FL-22, "Removal and Installation"](#).

## 7. CHECK INTERMITTENT INCIDENT

Refer to [GI-44, "Intermittent Incident"](#).

# P0451 EVAP CONTROL SYSTEM PRESSURE SENSOR

< DTC/CIRCUIT DIAGNOSIS >

[QR25DE]

>> INSPECTION END

## Component Inspection

INFOID:0000000011278044

### 1. CHECK EVAP CONTROL SYSTEM PRESSURE SENSOR

1. Turn ignition switch OFF.
2. Remove EVAP control system pressure sensor with its harness connector connected from EVAP canister.  
**Always replace O-ring with a new one.**
3. Install a vacuum pump to EVAP control system pressure sensor.
4. Turn ignition switch ON and check output voltage between ECM harness connector and ground under the following conditions.

Connector	ECM		Condition [Applied vacuum kPa (kg/cm <sup>2</sup> , psi)]	Voltage
	+	-		
Terminal				
E16	114	124	Not applied	0.5 - 4.6 V
			-26.7 (-0.272, -3.87)	2.1 to 2.5 V lower than above value

**CAUTION:**

- Always calibrate the vacuum pump gauge when using it.
- Do not apply below -93.3 kPa (-0.952 kg/cm<sup>2</sup>, -13.53 psi) or pressure over 101.3 kPa (1.033 kg/cm<sup>2</sup>, 14.69 psi).

Is the inspection result normal?

YES >> INSPECTION END

NO >> Replace EVAP control system pressure sensor. Refer to [FL-22. "Removal and Installation"](#).

# P0452 EVAP CONTROL SYSTEM PRESSURE SENSOR

< DTC/CIRCUIT DIAGNOSIS >

[QR25DE]

## P0452 EVAP CONTROL SYSTEM PRESSURE SENSOR

### DTC Description

INFOID:000000011278045

### DTC DETECTION LOGIC

DTC No.	CONSULT screen terms (Trouble diagnosis content)	DTC detecting condition
P0452	EVAP SYS PRES SEN (Evaporative emission system pressure sensor/switch low)	An excessively low voltage from the sensor is sent to ECM.

### POSSIBLE CAUSE

- Harness or connectors (EVAP control system pressure sensor circuit is shorted.)
- EVAP control system pressure sensor

### FAIL-SAFE

Not applicable

### DTC CONFIRMATION PROCEDURE

#### 1. PRECONDITIONING

If DTC Confirmation Procedure has been previously conducted, always perform the following procedure before conducting the next test.

1. Turn ignition switch OFF and wait at least 10 seconds.
2. Turn ignition switch ON.
3. Turn ignition switch OFF and wait at least 10 seconds.

#### TESTING CONDITION:

**Always perform test at a temperature of 5°C (41°F) or more.**

>> GO TO 2.

#### 2. PERFORM DTC CONFIRMATION PROCEDURE

##### With CONSULT

1. Start engine and warm it up to normal operating temperature.
2. Turn ignition switch OFF and wait at least 10 seconds.
3. Turn ignition switch ON.
4. Select "DATA MONITOR" mode of "ENGINE" using CONSULT.
5. Make sure that "FUEL T/TMP SE" indication is more than 0°C (32°F).
6. Start engine and wait at least 20 seconds.
7. Check 1st trip DTC.

##### With GST

1. Start engine and warm it up to normal operating temperature.
2. Set voltmeter probes to ECM harness connector terminals as per the following.

Connector	ECM		Voltage
	+	-	
	Terminal		
E16	114	124	Less than 4.2 V

3. Make sure that the voltage is less than 4.2 V.
4. Turn ignition switch OFF and wait at least 10 seconds.
5. Start engine and wait at least 20 seconds.
6. Check 1st trip DTC.

#### Is 1st trip DTC detected?

- YES >> Proceed to [EC-335, "Diagnosis Procedure"](#).  
NO >> INSPECTION END

# P0452 EVAP CONTROL SYSTEM PRESSURE SENSOR

< DTC/CIRCUIT DIAGNOSIS >

[QR25DE]

## Diagnosis Procedure

INFOID:000000011278046

### 1. CHECK EVAP CONTROL SYSTEM PRESSURE SENSOR CONNECTOR FOR WATER

1. Turn ignition switch OFF.
2. Disconnect EVAP control system pressure sensor harness connector.
3. Check sensor harness connector for water.

**Water should not exist.**

Is the inspection result normal?

YES >> GO TO 2.

NO >> Repair or replace harness connector.

### 2. CHECK EVAP CONTROL SYSTEM PRESSURE SENSOR POWER SUPPLY

1. Turn ignition switch ON.
2. Check the voltage between EVAP control system pressure sensor harness connector and ground.

+		-	Voltage (Approx.)
EVAP control system pressure sensor			
Connector	Terminal		
B111	3	Ground	5 V

Is the inspection result normal?

YES >> GO TO 4.

NO >> GO TO 3.

### 3. CHECK EVAP CONTROL SYSTEM PRESSURE SENSOR POWER SUPPLY CIRCUIT

1. Turn ignition switch OFF.
2. Disconnect ECM harness connector.
3. Check the continuity between EVAP control system pressure sensor harness connector and ECM harness connector.

+		-		Continuity
EVAP control system pressure sensor		ECM		
Connector	Terminal	Connector	Terminal	
B111	3	E16	113	Existed

4. Also check harness for short to ground and to power.

Is the inspection result normal?

YES >> Perform the trouble diagnosis for power supply circuit.

NO >> Repair or replace error-detected parts

### 4. CHECK EVAP CONTROL SYSTEM PRESSURE SENSOR GROUND CIRCUIT

1. Turn ignition switch OFF.
2. Disconnect ECM harness connector.
3. Check the continuity between EVAP control system pressure sensor harness connector and ECM harness connector.

+		-		Continuity
EVAP control system pressure sensor		ECM		
Connector	Terminal	Connector	Terminal	
B111	1	E16	124	Existed

4. Also check harness for short to power.

# P0452 EVAP CONTROL SYSTEM PRESSURE SENSOR

[QR25DE]

< DTC/CIRCUIT DIAGNOSIS >

Is the inspection result normal?

- YES >> GO TO 5.  
 NO >> Repair or replace error-detected parts.

## 5.CHECK EVAP CONTROL SYSTEM PRESSURE SENSOR SIGNAL CIRCUIT

1. Check the continuity between EVAP control system pressure sensor harness connector and ECM harness connector.

+		-		Continuity
EVAP control system pressure sensor		ECM		
Connector	Terminal	Connector	Terminal	
B111	2	E16	114	Existed

2. Also check harness for short to ground and to power.

Is the inspection result normal?

- YES >> GO TO 6.  
 NO >> Repair or replace error-detected parts.

## 6.CHECK EVAP CONTROL SYSTEM PRESSURE SENSOR

Check the EVAP control system pressure sensor. Refer to [EC-333. "Component Inspection"](#).

Is the inspection result normal?

- YES >> GO TO 7.  
 NO >> Replace EVAP control system pressure sensor. Refer to [FL-22. "Removal and Installation"](#).

## 7.CHECK INTERMITTENT INCIDENT

Refer to [GI-44. "Intermittent Incident"](#).

>> INSPECTION END

## Component Inspection

INFOID:0000000011278047

## 1.CHECK EVAP CONTROL SYSTEM PRESSURE SENSOR

- Turn ignition switch OFF.
- Remove EVAP control system pressure sensor with its harness connector connected from EVAP canister.  
**Always replace O-ring with a new one.**
- Install a vacuum pump to EVAP control system pressure sensor.
- Turn ignition switch ON and check output voltage between ECM harness connector and ground under the following conditions.

Connector	ECM		Condition [Applied vacuum kPa (kg/cm <sup>2</sup> , psi)]	Voltage
	+	-		
Terminal				
E16	114	124	Not applied	0.5 - 4.6 V
			-26.7 (-0.272, -3.87)	2.1 to 2.5 V lower than above value

### CAUTION:

- Always calibrate the vacuum pump gauge when using it.
- Do not apply below -93.3 kPa (-0.952 kg/cm<sup>2</sup>, -13.53 psi) or pressure over 101.3 kPa (1.033 kg/cm<sup>2</sup>, 14.69 psi).

Is the inspection result normal?

- YES >> INSPECTION END  
 NO >> Replace EVAP control system pressure sensor. Refer to [FL-22. "Removal and Installation"](#).



# P0453 EVAP CONTROL SYSTEM PRESSURE SENSOR

< DTC/CIRCUIT DIAGNOSIS >

[QR25DE]

## P0453 EVAP CONTROL SYSTEM PRESSURE SENSOR

### DTC Description

INFOID:0000000011278048

### DTC DETECTION LOGIC

DTC No.	CONSULT screen terms (Trouble diagnosis content)	DTC detecting condition
P0453	EVAP SYS PRES SEN (Evaporative emission system pressure sensor/switch high)	An excessively high voltage from the sensor is sent to ECM.

### POSSIBLE CAUSE

- Harness or connectors (EVAP control system pressure sensor circuit is shorted.)
- EVAP control system pressure sensor

### FAIL-SAFE

Not applicable

### DTC CONFIRMATION PROCEDURE

#### 1. PRECONDITIONING

If DTC Confirmation Procedure has been previously conducted, always perform the following procedure before conducting the next test.

1. Turn ignition switch OFF and wait at least 10 seconds.
2. Turn ignition switch ON.
3. Turn ignition switch OFF and wait at least 10 seconds.

#### TESTING CONDITION:

Always perform test at a temperature of 5°C (41°F) or more.

>> GO TO 2.

#### 2. PERFORM DTC CONFIRMATION PROCEDURE

##### Ⓜ With CONSULT

1. Start engine and warm it up to normal operating temperature.
2. Turn ignition switch OFF and wait at least 10 seconds.
3. Turn ignition switch ON.
4. Select "DATA MONITOR" mode of "ENGINE" using CONSULT.
5. Make sure that "FUEL T/TMP SE" indication is more than 0°C (32°F).
6. Start engine and wait at least 20 seconds.
7. Check 1st trip DTC.

##### Ⓜ With GST

1. Start engine and warm it up to normal operating temperature.
2. Set voltmeter probes to ECM harness connector terminals as per the following.

Connector	ECM		Voltage
	+	-	
E16	114	124	Less than 4.2 V

3. Make sure that the voltage is less than 4.2 V.
4. Turn ignition switch OFF and wait at least 10 seconds.
5. Start engine and wait at least 20 seconds.
6. Check 1st trip DTC.

#### Is 1st trip DTC detected?

- YES >> Proceed to [EC-338, "Diagnosis Procedure"](#).  
NO >> INSPECTION END

# P0453 EVAP CONTROL SYSTEM PRESSURE SENSOR

< DTC/CIRCUIT DIAGNOSIS >

[QR25DE]

INFOID:000000011278049

## Diagnosis Procedure

### 1. CHECK EVAP CONTROL SYSTEM PRESSURE SENSOR CONNECTOR FOR WATER

1. Turn ignition switch OFF.
2. Disconnect EVAP control system pressure sensor harness connector.
3. Check sensor harness connector for water.

**Water should not exist.**

Is the inspection result normal?

YES >> GO TO 2.

NO >> Repair or replace harness connector.

### 2. CHECK EVAP CONTROL SYSTEM PRESSURE SENSOR POWER SUPPLY

1. Turn ignition switch ON.
2. Check the voltage between EVAP control system pressure sensor harness connector and ground.

+		-	Voltage (Approx.)
EVAP control system pressure sensor			
Connector	Terminal		
B111	3	Ground	5 V

Is the inspection result normal?

YES >> GO TO 4.

NO >> GO TO 3.

### 3. CHECK EVAP CONTROL SYSTEM PRESSURE SENSOR POWER SUPPLY CIRCUIT

1. Turn ignition switch OFF.
2. Disconnect ECM harness connector.
3. Check the continuity between EVAP control system pressure sensor harness connector and ECM harness connector.

+		-		Continuity
EVAP control system pressure sensor		ECM		
Connector	Terminal	Connector	Terminal	
B111	3	E16	113	Existed

4. Also check harness for short to ground and to power.

Is the inspection result normal?

YES >> Perform the trouble diagnosis for power supply circuit.

NO >> Repair or replace error-detected parts

### 4. CHECK EVAP CONTROL SYSTEM PRESSURE SENSOR GROUND CIRCUIT

1. Turn ignition switch OFF.
2. Disconnect ECM harness connector.
3. Check the continuity between EVAP control system pressure sensor harness connector and ECM harness connector.

+		-		Continuity
EVAP control system pressure sensor		ECM		
Connector	Terminal	Connector	Terminal	
B111	1	E16	124	Existed

4. Also check harness for short to power.

# P0453 EVAP CONTROL SYSTEM PRESSURE SENSOR

[QR25DE]

< DTC/CIRCUIT DIAGNOSIS >

Is the inspection result normal?

- YES >> GO TO 5.
- NO >> Repair or replace error-detected parts.

## 5.CHECK EVAP CONTROL SYSTEM PRESSURE SENSOR SIGNAL CIRCUIT

1. Check the continuity between EVAP control system pressure sensor harness connector and ECM harness connector.

+		-		Continuity
EVAP control system pressure sensor		ECM		
Connector	Terminal	Connector	Terminal	
B111	2	E16	114	Existed

2. Also check harness for short to ground and to power.

Is the inspection result normal?

- YES >> GO TO 6.
- NO >> Repair or replace error-detected parts.

## 6.CHECK RUBBER TUBE

1. Disconnect rubber tube connected to EVAP canister vent control valve.
2. Check the rubber tube for clogging.

Is the inspection result normal?

- YES >> GO TO 7.
- NO >> Clean the rubber tube using an air blower, repair or replace rubber tube.

## 7.CHECK EVAP CANISTER VENT CONTROL VALVE

Refer to [EC-324. "Component Inspection"](#).

Is the inspection result normal?

- YES >> GO TO 8.
- NO >> Replace EVAP canister vent control valve. Refer to [FL-21. "Removal and Installation"](#).

## 8.CHECK EVAP CONTROL SYSTEM PRESSURE SENSOR

Refer to [EC-340. "Component Inspection"](#).

Is the inspection result normal?

- YES >> GO TO 9.
- NO >> Replace EVAP control system pressure sensor. Refer to [FL-22. "Removal and Installation"](#).

## 9.CHECK IF EVAP CANISTER IS SATURATED WITH WATER

1. Remove EVAP canister with EVAP canister vent control valve and EVAP control system pressure sensor attached.
2. Check if water will drain from the EVAP canister.

Does water drain from EVAP canister?

- YES >> GO TO 10.
- NO >> GO TO 12.

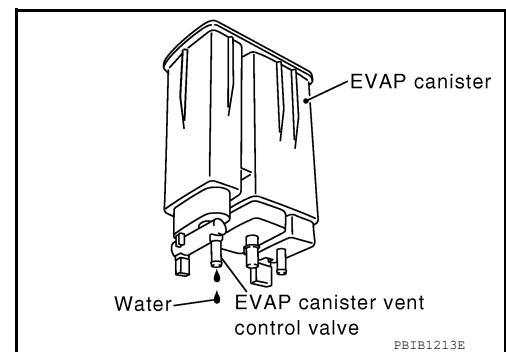

## 10.CHECK EVAP CANISTER

Weigh the EVAP canister with the EVAP canister vent control valve and EVAP control system pressure sensor attached.

**The weight should be less than 1.9 kg (4.2 lb).**

# P0453 EVAP CONTROL SYSTEM PRESSURE SENSOR

[QR25DE]

< DTC/CIRCUIT DIAGNOSIS >

Is the inspection result normal?

- YES >> GO TO 12.
- NO >> GO TO 11.

## 11. DETECT MALFUNCTIONING PART

Check the following.

- EVAP canister for damage
- EVAP hose between EVAP canister and vehicle frame for clogging or poor connection

>> Repair hose or replace EVAP canister. Refer to [FL-19, "Removal and Installation"](#).

## 12. CHECK INTERMITTENT INCIDENT

Refer to [GI-44, "Intermittent Incident"](#).

>> INSPECTION END

## Component Inspection

INFOID:000000011278050

### 1. CHECK EVAP CONTROL SYSTEM PRESSURE SENSOR

1. Turn ignition switch OFF.
2. Remove EVAP control system pressure sensor with its harness connector connected from EVAP canister.  
**Always replace O-ring with a new one.**
3. Install a vacuum pump to EVAP control system pressure sensor.
4. Turn ignition switch ON and check output voltage between ECM harness connector and ground under the following conditions.

ECM			Condition [Applied vacuum kPa (kg/cm <sup>2</sup> , psi)]	Voltage
Connector	+	-		
Terminal				
E16	114	124	Not applied	0.5 - 4.6 V
			-26.7 (-0.272, -3.87)	2.1 to 2.5 V lower than above value

#### CAUTION:

- **Always calibrate the vacuum pump gauge when using it.**
- **Do not apply below -93.3 kPa (-0.952 kg/cm<sup>2</sup>, -13.53 psi) or pressure over 101.3 kPa (1.033 kg/cm<sup>2</sup>, 14.69 psi).**

Is the inspection result normal?

- YES >> INSPECTION END
- NO >> Replace EVAP control system pressure sensor. Refer to [FL-22, "Removal and Installation"](#).

# P0456 EVAP CONTROL SYSTEM

< DTC/CIRCUIT DIAGNOSIS >

[QR25DE]

## P0456 EVAP CONTROL SYSTEM

### DTC Description

INFOID:0000000011278051

### DTC DETECTION LOGIC

This diagnosis detects leaks in the EVAP line between fuel tank and EVAP canister purge volume control solenoid valve, using the negative pressure caused by decrease of fuel temperature in the fuel tank after turning ignition switch OFF.

If ECM judges there are no leaks, the diagnosis will be OK.

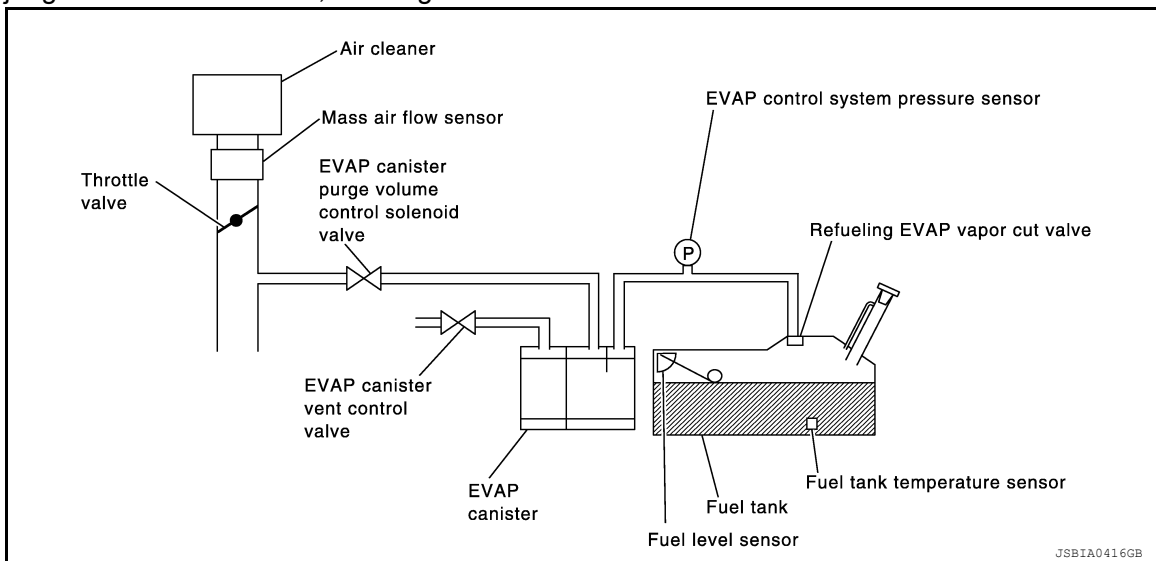

DTC No.	CONSULT screen terms (Trouble diagnosis content)	DTC detecting condition
P0456	EVAP VERY SML LEAK [Evaporative emission system leak detected (very small leak)]	<ul style="list-style-type: none"> <li>• EVAP system has a leak.</li> <li>• EVAP system does not operate properly.</li> </ul>

### CAUTION:

- Use only a genuine NISSAN fuel filler cap as a replacement. If an incorrect fuel filler cap is used, the MIL may illuminate.
- If the fuel filler cap is not tightened properly, the MIL may illuminate.
- Use only a genuine NISSAN rubber tube as a replacement.

### POSSIBLE CAUSE

- Incorrect fuel tank vacuum relief valve
- Incorrect fuel filler cap used
- Fuel filler cap remains open or does not close.
- Foreign matter caught in fuel filler cap.
- Leak is in line between intake manifold and EVAP canister purge volume control solenoid valve.
- Foreign matter caught in EVAP canister vent control valve.
- EVAP canister or fuel tank leaks
- EVAP purge line (pipe and rubber tube) leaks
- EVAP purge line rubber tube bent
- Loose or disconnected rubber tube
- EVAP canister vent control valve and the circuit
- EVAP canister purge volume control solenoid valve and the circuit
- Fuel tank temperature sensor
- O-ring of EVAP canister vent control valve is missing or damaged
- EVAP canister is saturated with water
- EVAP control system pressure sensor
- Refueling EVAP vapor cut valve
- ORVR system leaks
- Fuel level sensor and the circuit
- Foreign matter caught in EVAP canister purge volume control solenoid valve

# P0456 EVAP CONTROL SYSTEM

[QR25DE]

< DTC/CIRCUIT DIAGNOSIS >

## FAIL-SAFE

Not applicable

## DTC CONFIRMATION PROCEDURE

### 1. PRECONDITIONING

If DTC Confirmation Procedure has been previously conducted, always perform the following before conducting the next test.

1. Turn ignition switch OFF and wait at least 10 seconds.
2. Turn ignition switch ON.
3. Turn ignition switch OFF and wait at least 10 seconds.

Do you have CONSULT?

- YES >> GO TO 2.  
NO >> GO TO 4.

### 2. PERFORM DTC CONFIRMATION PROCEDURE-1

Ⓜ WITH CONSULT

1. Turn ignition switch ON and select "EVAP DIAG READY" in "DATA MONITOR" mode of "ENGINE" using CONSULT.
2. Start engine and wait at idle until "OFF" of "EVAP DIAG READY" changes to "ON".

**NOTE:**

**It will take at most 2 hours until "OFF" of "EVAP DIAG READY" changes to "ON".**

3. Turn ignition switch OFF and wait at least 90 minutes.

**NOTE:**

**Never turn ignition switch ON during 90 minutes.**

4. Turn ignition switch ON and select "EVAP LEAK DIAG" in "DATA MONITOR" mode of "ENGINE" using CONSULT.
5. Check that "EVAP LEAK DIAG" indication.

Which is displayed on CONSULT?

- CMPLT >> GO TO 3.  
YET >> Perform DTC CONFIRMATION PROCEDURE again. GO TO 1.

### 3. PERFORM DTC CONFIRMATION PROCEDURE-2

Check 1st trip DTC.

Is 1st trip DTC detected?

- YES >> Proceed to [EC-342. "Diagnosis Procedure"](#).  
NO >> INSPECTION END.

### 4. PERFORM DTC CONFIRMATION PROCEDURE

Ⓜ WITH GST

1. Start engine and wait engine idle for at least 2 hours.
2. Turn ignition switch OFF and wait at least 90 minutes.

**NOTE:**

**Never turn ignition switch ON during 90 minutes.**

3. Turn ignition switch ON.
4. Check 1st trip DTC.

Is 1st trip DTC detected?

- YES >> Proceed to [EC-342. "Diagnosis Procedure"](#).  
NO >> INSPECTION END.

## Diagnosis Procedure

INFOID:000000011278052

### 1. CHECK FUEL FILLER CAP DESIGN

1. Turn ignition switch OFF.

# P0456 EVAP CONTROL SYSTEM

[QR25DE]

< DTC/CIRCUIT DIAGNOSIS >

2. Check for genuine NISSAN fuel filler cap design.

Is the inspection result normal?

YES >> GO TO 2.

NO >> Replace with genuine NISSAN fuel filler cap.

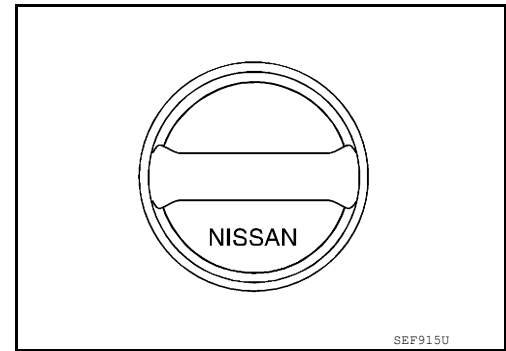

## 2. CHECK FUEL FILLER CAP INSTALLATION

Check that the cap is tightened properly by rotating the cap clockwise.

Is the inspection result normal?

YES >> GO TO 3.

NO >> Open fuel filler cap, then clean cap and fuel filler neck threads using air blower. Then retighten until rereaching sound is heard.

## 3. CHECK FUEL FILLER CAP FUNCTION

Check for air releasing sound while opening the fuel filler cap.

Is the inspection result normal?

YES >> GO TO 5.

NO >> GO TO 4.

## 4. CHECK FUEL TANK VACUUM RELIEF VALVE

Refer to [EC-346. "Component Inspection"](#).

Is the inspection result normal?

YES >> GO TO 5.

NO >> Replace fuel filler cap with a genuine one.

## 5. CHECK FOR EVAP LEAK

Refer to [EC-499. "Inspection"](#).

Is there any leak in EVAP line?

YES >> Repair or replace.

NO >> GO TO 6.

## 6. CHECK EVAP CANISTER VENT CONTROL VALVE

Check the following.

- EVAP canister vent control valve is installed properly.

Refer to [FL-21. "Exploded View"](#).

- EVAP canister vent control valve.

Refer to [FL-21. "Removal and Installation"](#).

Is the inspection result normal?

YES >> GO TO 7.

NO >> Repair or replace EVAP canister vent control valve and O-ring. Refer to [FL-21. "Removal and Installation"](#).

## 7. CHECK IF EVAP CANISTER SATURATED WITH WATER

1. Remove EVAP canister with EVAP canister vent control valve and EVAP control system pressure sensor attached.

## P0456 EVAP CONTROL SYSTEM

[QR25DE]

### < DTC/CIRCUIT DIAGNOSIS >

2. Check if water will drain from the EVAP canister.

#### Does water drain from EVAP canister?

- YES >> GO TO 8.
- NO-1 >> With CONSULT: GO TO 10.
- NO-2 >> Without CONSULT: GO TO 11.

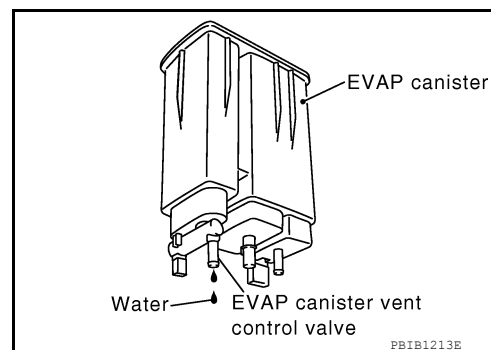

## 8. CHECK EVAP CANISTER

Weigh the EVAP canister assembly with the EVAP canister vent control valve and EVAP control system pressure sensor attached. Refer to [FL-21, "Removal and Installation"](#).

**The weight should be less than 2.1 kg (4.6 lb).**

#### Is the inspection result normal?

- YES-1 >> With CONSULT: GO TO 10.
- YES-2 >> Without CONSULT: GO TO 11.
- NO >> GO TO 9.

## 9. DETECT MALFUNCTIONING PART

Check the following.

- EVAP canister for damage
- EVAP hose between EVAP canister and vehicle frame for clogging or poor connection

>> Repair hose or replace EVAP canister. Refer to [FL-19, "Removal and Installation"](#).

## 10. CHECK EVAP CANISTER PURGE VOLUME CONTROL SOLENOID VALVE OPERATION

### With CONSULT

1. Disconnect vacuum hose to EVAP canister purge volume control solenoid valve at EVAP service port.
2. Start engine and let it idle.
3. Select "PURG VOL CONT/V" in "ACTIVE TEST" mode of "ENGINE" using CONSULT.
4. Touch "Qu" on CONSULT screen to increase "PURG VOL CONT/V" opening to 100%.
5. Check vacuum hose for vacuum.

**Vacuum should exist.**

#### Is the inspection result normal?

- YES >> GO TO 13.
- NO >> GO TO 12.

## 11. CHECK EVAP CANISTER PURGE VOLUME CONTROL SOLENOID VALVE OPERATION

### Without CONSULT

1. Start engine and warm it up to normal operating temperature.
2. Stop engine.
3. Disconnect vacuum hose to EVAP canister purge volume control solenoid valve at EVAP service port.
4. Start engine and let it idle for at least 80 seconds.
5. Check vacuum hose for vacuum when revving engine up to 2,000 rpm.

**Vacuum should exist.**

#### Is the inspection result normal?

- YES >> GO TO 13.
- NO >> GO TO 12.

## 12. CHECK VACUUM HOSE

Check vacuum hoses for clogging or disconnection.

#### Is the inspection result normal?



## P0456 EVAP CONTROL SYSTEM

[QR25DE]

< DTC/CIRCUIT DIAGNOSIS >

- YES >> GO TO 13.  
NO >> Repair or reconnect the hose.

### 13. CHECK EVAP CANISTER PURGE VOLUME CONTROL SOLENOID VALVE

Check the EVAP canister purge volume control solenoid valve. Refer to [EC-318, "Component Inspection"](#).

Is the inspection result normal?

- YES >> GO TO 14.  
NO >> Replace EVAP canister purge volume control solenoid valve. Refer to [EC-14, "Component Parts Location"](#).

### 14. CHECK FUEL TANK TEMPERATURE SENSOR

Check the fuel tank temperature sensor. Refer to [EC-276, "Component Inspection"](#).

Is the inspection result normal?

- YES >> GO TO 15.  
NO >> Replace fuel level sensor unit. Refer to [FL-5, "Removal and Installation"](#).

### 15. CHECK EVAP CONTROL SYSTEM PRESSURE SENSOR

Check the EVAP control system pressure sensor. Refer to [FL-22, "Removal and Installation"](#).

Is the inspection result normal?

- YES >> GO TO 16.  
NO >> Replace EVAP control system pressure sensor. Refer to [FL-22, "Removal and Installation"](#).

### 16. CHECK EVAP PURGE LINE

Check EVAP purge line (pipe, rubber tube, fuel tank and EVAP canister) for cracks or improper connection. Refer to [EC-55, "EVAPORATIVE EMISSION SYSTEM : System Description"](#).

Is the inspection result normal?

- YES >> GO TO 17.  
NO >> Repair or reconnect the hose.

### 17. CLEAN EVAP PURGE LINE

Clean EVAP purge line (pipe and rubber tube) using air blower.

>> GO TO 18.

### 18. CHECK EVAP/ORVR LINE

Check EVAP/ORVR line between EVAP canister and fuel tank for clogging, kink, looseness and improper connection. For location, refer to [EC-55, "EVAPORATIVE EMISSION SYSTEM : System Description"](#).

Is the inspection result normal?

- YES >> GO TO 19.  
NO >> Repair or replace hoses and tubes.

### 19. CHECK RECIRCULATION LINE

Check recirculation line between fuel filler tube and fuel tank for clogging, kink, cracks, looseness and improper connection.

Is the inspection result normal?

- YES >> GO TO 20.  
NO >> Repair or replace hose, tube or fuel filler tube. Refer to [FL-11, "FWD : Exploded View"](#) (with FWD models) or [FL-15, "AWD : Exploded View"](#) (with AWD models).

### 20. CHECK REFUELING EVAP VAPOR CUT VALVE

Check the refueling EVAP vapor cut valve. Refer to [FL-14, "FWD : Inspection"](#) (with FWD models) or [FL-18, "AWD : Inspection"](#) (with AWD models).

Is the inspection result normal?

- YES >> GO TO 21.  
NO >> Replace refueling EVAP vapor cut valve with fuel tank. Refer to [FL-11, "FWD : Removal and Installation"](#) (with FWD models) or [FL-15, "AWD : Removal and Installation"](#) (with AWD models).

# P0456 EVAP CONTROL SYSTEM

< DTC/CIRCUIT DIAGNOSIS >

[QR25DE]

## 21. CHECK FUEL LEVEL SENSOR

Check the fuel level sensor. Refer to [MWI-64, "Component Inspection"](#).

Is the inspection result normal?

YES >> GO TO 22.

NO >> Replace fuel level sensor unit. Refer to [FL-5, "Removal and Installation"](#).

## 22. CHECK INTERMITTENT INCIDENT

Refer to [GI-44, "Intermittent Incident"](#).

>> INSPECTION END

## Component Inspection

INFOID:000000011278053

### 1. CHECK FUEL FILLER CAP

1. Turn ignition switch OFF.
2. Remove fuel filler cap.
3. Wipe clean valve housing.

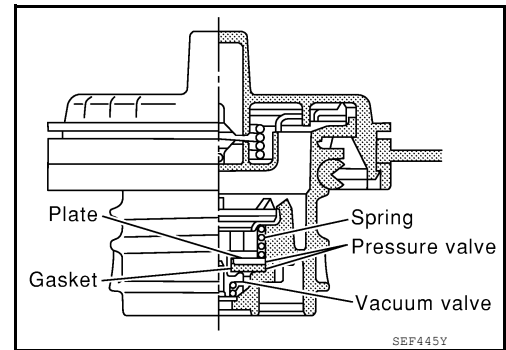

4. Install fuel filler cap adapter (commercial service tool) to fuel filler cap.
5. Check valve opening pressure and vacuum.

**Pressure:** 15.3 - 20.0 kPa (0.156 - 0.204 kg/cm<sup>2</sup>, 2.22 - 2.90 psi)

**Vacuum:** -6.0 to -3.3 kPa (-0.061 to -0.034 kg/cm<sup>2</sup>, -0.87 to -0.48 psi)

Is the inspection result normal?

YES >> INSPECTION END

NO >> GO TO 2.

### 2. REPLACE FUEL FILLER CAP

Replace fuel filler cap.

#### **CAUTION:**

**Use only a genuine fuel filler cap as a replacement. If an incorrect fuel filler cap is used, the MIL may illuminate.**

>> INSPECTION END

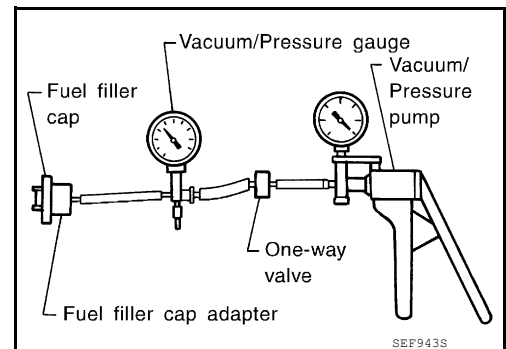

# P0460 FUEL LEVEL SENSOR

< DTC/CIRCUIT DIAGNOSIS >

[QR25DE]

## P0460 FUEL LEVEL SENSOR

### DTC Description

INFOID:0000000011278054

### DTC DETECTION LOGIC

When the vehicle is parked, naturally the fuel level in the fuel tank is stable. It means that output signal of the fuel level sensor does not change. If ECM senses sloshing signal from the sensor, fuel level sensor malfunction is detected.

DTC No.	CONSULT screen terms (Trouble diagnosis content)	DTC detecting condition
P0460	FUEL LEV SEN SLOSH (Fuel Level Sensor "A" Circuit)	Even though the vehicle is parked, a signal being varied is sent from the fuel level sensor to ECM.

### POSSIBLE CAUSE

- Harness or connectors (The CAN communication line is open or shorted.)
- Harness or connectors (The sensor circuit is open or shorted.)
- Combination meter
- Fuel level sensor

### FAIL-SAFE

Not applicable

### DTC CONFIRMATION PROCEDURE

#### 1.CHECK DTC PRIORITY

If DTC P0460 is displayed with DTC UXXXX or P0607, first perform the trouble diagnosis for DTC UXXXX or P0607.

#### Is applicable DTC detected?

- YES >> Perform diagnosis of applicable. Refer to [EC-96. "DTC Index"](#).  
NO >> GO TO 2.

#### 2.PRECONDITIONING

If DTC Confirmation Procedure has been previously conducted, always perform the following procedure before conducting the next test.

1. Turn ignition switch OFF and wait at least 10 seconds.
2. Turn ignition switch ON.
3. Turn ignition switch OFF and wait at least 10 seconds.

>> GO TO 3.

#### 3.PERFORM DTC CONFIRMATION PROCEDURE

1. Start engine and wait maximum of 2 consecutive minutes.
2. Check 1st trip DTC.

#### Is 1st trip DTC detected?

- YES >> Proceed to [EC-347. "Diagnosis Procedure"](#).  
NO >> INSPECTION END

### Diagnosis Procedure

INFOID:0000000011278055

#### 1.CHECK DTC PRIORITY

If DTC P0460 is displayed with DTC UXXXX or P0607, first perform the trouble diagnosis for DTC UXXXX or P0607.

#### Is applicable DTC detected?

- YES >> Perform diagnosis of applicable. Refer to [EC-96. "DTC Index"](#).  
NO >> GO TO 2.

#### 2.CHECK COMBINATION METER FUNCTION

## P0460 FUEL LEVEL SENSOR

[QR25DE]

< DTC/CIRCUIT DIAGNOSIS >

---

Refer to [MWI-21, "CONSULT Function \(METER/M&A\)"](#).

Is the inspection result normal?

YES >> GO TO 3.

NO >> Refer to [MWI-63, "Component Function Check"](#).

**3**.CHECK INTERMITTENT INCIDENT

---

Refer to [GI-44, "Intermittent Incident"](#).

>> INSPECTION END

# P0461 FUEL LEVEL SENSOR

< DTC/CIRCUIT DIAGNOSIS >

[QR25DE]

## P0461 FUEL LEVEL SENSOR

### DTC Description

INFOID:0000000011278056

### DTC DETECTION LOGIC

Driving long distances naturally affect fuel gauge level.

This diagnosis detects the fuel gauge malfunction of the gauge not moving even after a long distance has been driven.

DTC No.	CONSULT screen terms (Trouble diagnosis content)	DTC detecting condition
P0461	FUEL LEVEL SENSOR (Fuel level sensor "A" circuit range/performance)	The output signal of the fuel level sensor does not change within the specified range even though the vehicle has been driven a long distance.

### POSSIBLE CAUSE

- Harness or connectors (The CAN communication line is open or shorted.)
- Harness or connectors (The sensor circuit is open or shorted.)
- Combination meter
- Fuel level sensor

### FAIL-SAFE

Not applicable

### DTC CONFIRMATION PROCEDURE

#### 1. CHECK DTC PRIORITY

If DTC P0461 is displayed with DTC UXXXX or P0607, first perform the trouble diagnosis for DTC UXXXX or P0607.

#### Is applicable DTC detected?

- YES >> Perform diagnosis of applicable. Refer to [EC-96. "DTC Index"](#).
- NO >> GO TO 2.

#### 2. PRECONDITIONING

#### **WARNING:**

When performing following procedure, be sure to observe the handling of the fuel. Refer to [FL-2. "General Precaution"](#).

#### TESTING CONDITION:

Before starting component function check, preparation of draining fuel and refilling fuel is required.

#### Do you have CONSULT?

- YES >> GO TO 3.
- NO >> GO TO 4.

#### 3. PERFORM COMPONENT FUNCTION CHECK

Ⓜ With CONSULT

#### NOTE:

Start from step 10, if it is possible to confirm that the fuel cannot be drained by 30 ℓ (7-7/8 US gal, 6-5/8 Imp gal) in advance.

1. Prepare a fuel container and a spare hose.
2. Release fuel pressure from fuel line, refer to [EC-147. "Work Procedure"](#).
3. Remove the fuel feed hose on the fuel level sensor unit.
4. Connect a spare fuel hose where the fuel feed hose was removed.
5. Turn ignition switch OFF and wait at least 10 seconds then turn ON.
6. Select "FUEL LEVEL SE" in "DATA MONITOR" mode of "ENGINE" using CONSULT.
7. Check "FUEL LEVEL SE" output voltage and note it.
8. Select "FUEL PUMP RELAY" in "ACTIVE TEST" mode of "ENGINE" using CONSULT.
9. Touch "ON" and drain fuel approximately 30 ℓ (7-7/8 US gal, 6-5/8 Imp gal) and stop it.
10. Check "FUEL LEVEL SE" output voltage and note it.

# P0461 FUEL LEVEL SENSOR

[QR25DE]

< DTC/CIRCUIT DIAGNOSIS >

11. Fill fuel into the fuel tank for 30 ℓ (7-7/8 US gal, 6-5/8 Imp gal).
12. Check "FUEL LEVEL SE" output voltage and note it.
13. Confirm whether the voltage changes more than 0.03 V during step 7 to 10 and 10 to 12.

Is the inspection result normal?

- YES >> INSPECTION END  
NO >> Proceed to [EC-350, "Diagnosis Procedure"](#).

## 4.PERFORM COMPONENT FUNCTION CHECK

Without CONSULT

**NOTE:**

**Start from step 8, if it is possible to confirm that the fuel cannot be drained by 30 ℓ (7-7/8 US gal, 6-5/8 Imp gal) in advance.**

1. Prepare a fuel container and a spare hose.
2. Release fuel pressure from fuel line. Refer to [EC-147, "Work Procedure"](#).
3. Remove the fuel feed hose on the fuel level sensor unit.
4. Connect a spare fuel hose where the fuel feed hose was removed.
5. Turn ignition switch ON.
6. Drain fuel by 30 ℓ (7-7/8 US gal, 6-5/8 Imp gal) from the fuel tank using proper equipment.
7. Confirm that the fuel gauge indication varies.
8. Fill fuel into the fuel tank for 30 ℓ (7-7/8 US gal, 6-5/8 Imp gal).
9. Confirm that the fuel gauge indication varies.

Is the inspection result normal?

- YES >> INSPECTION END  
NO >> Proceed to [EC-350, "Diagnosis Procedure"](#).

## Diagnosis Procedure

INFOID:000000011278057

### 1.CHECK DTC PRIORITY

If DTC P0461 is displayed with DTC UXXXX or P0607, first perform the trouble diagnosis for DTC UXXXX or P0607.

Is applicable DTC detected?

- YES >> Perform diagnosis of applicable. Refer to [EC-96, "DTC Index"](#).  
NO >> GO TO 2.

### 2.CHECK COMBINATION METER FUNCTION

Refer to [MWI-21, "CONSULT Function \(METER/M&A\)"](#).

Is the inspection result normal?

- YES >> GO TO 3.  
NO >> Refer to [MWI-63, "Component Function Check"](#)

### 3.CHECK INTERMITTENT INCIDENT

Refer to [GI-44, "Intermittent Incident"](#).

>> INSPECTION END

# P0462, P0463 FUEL LEVEL SENSOR

< DTC/CIRCUIT DIAGNOSIS >

[QR25DE]

## P0462, P0463 FUEL LEVEL SENSOR

### DTC Description

INFOID:0000000011278058

### DTC DETECTION LOGIC

This diagnosis indicates the former, to detect open or short circuit malfunction.

DTC No.	CONSULT screen terms (Trouble diagnosis content)	DTC detecting condition
P0462	FUEL LEVL SEN/CIRC (Fuel level sensor "A" circuit low)	An excessively low voltage from the sensor is sent to ECM.
P0463	FUEL LEVL SEN/CIRC (Fuel level sensor "A" circuit high)	An excessively high voltage from the sensor is sent to ECM.

### POSSIBLE CAUSE

- Harness or connectors (The CAN communication line is open or shorted.)
- Harness or connectors (The sensor circuit is open or shorted.)
- Combination meter
- Fuel level sensor

### FAIL-SAFE

Not applicable

### DTC CONFIRMATION PROCEDURE

#### 1.CHECK DTC PRIORITY

If DTC P0462 or P0463 is displayed with DTC UXXXX or P0607, first perform the trouble diagnosis for DTC UXXXX or P0607.

#### Is applicable DTC detected?

- YES >> Perform diagnosis of applicable. Refer to [EC-96. "DTC Index"](#).
- NO >> GO TO 2.

#### 2.PRECONDITIONING

If DTC Confirmation Procedure has been previously conducted, always turn ignition switch OFF and wait at least 10 seconds before conducting the next test.

#### **TESTING CONDITION:**

**Before performing the following procedure, confirm that battery voltage is between 11 V and 16 V at ignition switch ON.**

>> GO TO 3.

#### 3.PERFORM DTC CONFIRMATION PROCEDURE

1. Turn ignition switch ON and wait at least 5 seconds.
2. Check 1st trip DTC.

#### Is 1st trip DTC detected?

- YES >> Proceed to [EC-351. "Diagnosis Procedure"](#).
- NO >> INSPECTION END

### Diagnosis Procedure

INFOID:0000000011278059

#### 1.CHECK DTC PRIORITY

If DTC P0462 or P0463 is displayed with DTC UXXXX or P0607, first perform the trouble diagnosis for DTC UXXXX or P0607.

#### Is applicable DTC detected?

- YES >> Perform diagnosis of applicable. Refer to [EC-96. "DTC Index"](#).
- NO >> GO TO 2.

#### 2.CHECK COMBINATION METER FUNCTION

## P0462, P0463 FUEL LEVEL SENSOR

[QR25DE]

< DTC/CIRCUIT DIAGNOSIS >

---

Refer to [MWI-21, "CONSULT Function \(METER/M&A\)"](#).

Is the inspection result normal?

YES >> GO TO 3.

NO >> Proceed to [MWI-63, "Component Function Check"](#).

### 3.CHECK INTERMITTENT INCIDENT

---

Refer to [GI-44, "Intermittent Incident"](#).

>> INSPECTION END



P0500 VSS

Description

INFOID:0000000011278060

ECM receives vehicle speed signals from two different paths via CAN communication line: One is from the ABS actuator and electric unit (control unit) via the combination unit and the other is from TCM.

DTC Description

INFOID:0000000011278061

DTC DETECTION LOGIC

DTC No.	CONSULT screen terms (Trouble diagnosis content)	DTC detecting condition
P0500	VEHICLE SPEED SENSOR A (Vehicle speed sensor "A")	At 20 km/h (13 MPH), ECM detects the following status continuously for 5 seconds or more: The difference between a vehicle speed calculated by a output speed sensor transmitted from TCM to ECM via CAN communication and the vehicle speed indicated on the combination meter exceeds 15km/h (10 MPH).

POSSIBLE CAUSE

- Harness or connectors (CAN communication line is open or shorted.)
- Combination meter
- ABS actuator and electric unit (control unit)
- Wheel sensor
- TCM
- Output speed sensor

FAIL-SAFE

Traveling control mode (Accelerator angle variation control)

DTC CONFIRMATION PROCEDURE

1.CHECK DTC PRIORITY

If DTC P0500 is displayed with DTC UXXXX or P0607, first perform the trouble diagnosis for DTC UXXXX or P0607.

Is applicable DTC detected?

- YES >> Perform diagnosis of applicable. Refer to [EC-96, "DTC Index"](#).
- NO >> GO TO 2.

2.PRECONDITIONING

If DTC Confirmation Procedure has been previously conducted, always perform the following procedure before conducting the next test.

1. Turn ignition switch OFF and wait at least 10 seconds.
2. Turn ignition switch ON.
3. Turn ignition switch OFF and wait at least 10 seconds.

**TESTING CONDITION:**

**Before performing the following procedure, confirm that battery voltage is 10 V or more at idle.**

>> GO TO 3.

3.PERFORM DTC CONFIRMATION PROCEDURE

1. Start engine.
2. Shift the selector lever to D range and wait at least for 2 seconds.
3. Drive the vehicle at least 5 seconds at 20 km/h (13 MPH) or more.

**CAUTION:**

**Always drive vehicle at a safe speed.**

**NOTE:**

This procedure may be conducted with the drive wheels lifted in the shop or by driving the vehicle. If a road test is expected to be easier, it is unnecessary to lift the vehicle.

4. Check 1st trip DTC.

< DTC/CIRCUIT DIAGNOSIS >

Is 1st trip DTC detected?

- YES >> Proceed to [EC-354, "Diagnosis Procedure"](#)
- NO >> INSPECTION END

Diagnosis Procedure

INFOID:000000011278062

**1.**CHECK DTC PRIORITY

If DTC P0500 is displayed with DTC UXXXX or P0607, first perform the trouble diagnosis for DTC UXXXX or P0607.

Is applicable DTC detected?

- YES >> Perform diagnosis of applicable. Refer to [EC-96, "DTC Index"](#).
- NO >> GO TO 2.

**2.**CHECK DTC WITH TCM

Check DTC with TCM. Refer to [TM-63, "DTC Index"](#).

Is the inspection result normal?

- YES >> GO TO 3.
- NO >> Perform trouble shooting relevant to DTC indicated.

**3.**CHECK DTC WITH ABS ACTUATOR AND ELECTRIC UNIT (CONTROL UNIT)

Check DTC with ABS actuator and electric unit (control unit). Refer to [BRC-53, "DTC Index"](#).

Is the inspection result normal?

- YES >> GO TO 4.
- NO >> Perform trouble shooting relevant to DTC indicated.

**4.**CHECK DTC WITH COMBINATION METER

Check DTC with combination meter. Refer to [MWI-31, "DTC Index"](#).

Is the inspection result normal?

- YES >> GO TO 5.
- NO >> Perform trouble shooting relevant to DTC indicated.

**5.**CHECK INPUT SPEED SENSOR

Check input speed sensor. Refer to [TM-125, "Diagnosis Procedure"](#).

Is the inspection result normal?

- YES >> GO TO 6.
- NO >> Replace or replace error-detected parts.

**6.**CHECK WHEEL SENSOR

Check wheel sensor. Refer to [BRC-72, "Diagnosis Procedure"](#).

Is the inspection result normal?

- YES >> GO TO 7.
- NO >> Replace or replace error-detected parts.

**7.**CHECK INTERMITTENT INCIDENT

Refer to [GI-44, "Intermittent Incident"](#).

>> INSPECTION END

P0506 ISC SYSTEM

Description

INFOID:0000000011278063

The ECM controls the engine idle speed to a specified level through the fine adjustment of the air, which is let into the intake manifold, by operating the electric throttle control actuator. The operating of the throttle valve is varied to allow for optimum control of the engine idling speed. The crankshaft position sensor (POS) detects the actual engine speed and sends a signal to the ECM.

The ECM controls the electric throttle control actuator so that the engine speed coincides with the target value memorized in the ECM. The target engine speed is the lowest speed at which the engine can operate steadily. The optimum value stored in the ECM is determined by taking into consideration various engine conditions, such as during warming up, deceleration, and engine load (air conditioner, power steering and cooling fan operation, etc.).

DTC Description

INFOID:0000000011278064

DTC DETECTION LOGIC

DTC No.	CONSULT screen terms (Trouble diagnosis content)	DTC detecting condition
P0506	ISC SYSTEM (Idle air control system RPM lower than expected)	The idle speed is less than the target idle speed by 100 rpm or more.

POSSIBLE CAUSE

- Electric throttle control actuator
- Intake air leak

FAIL-SAFE

Not applicable

DTC CONFIRMATION PROCEDURE

1. CHECK DTC PRIORITY

If DTC P0506 is displayed with other DTC, first perform the trouble diagnosis for other DTC.

Is applicable DTC detected?

- YES >> Perform diagnosis of applicable. Refer to [EC-96, "DTC Index"](#).
- NO >> GO TO 2.

2. PRECONDITIONING

If DTC Confirmation Procedure has been previously conducted, always perform the following procedure before conducting the next test.

1. Turn ignition switch OFF and wait at least 10 seconds.
2. Turn ignition switch ON.
3. Turn ignition switch OFF and wait at least 10 seconds.

**If the target idle speed is out of the specified value, perform [EC-144, "Work Procedure"](#), before conducting DTC Confirmation Procedure.**

**TESTING CONDITION:**

- Before performing the following procedure, confirm that battery voltage is more than 11 V at idle.
- Always perform the test at a temperature above -10°C (14°F).

>> GO TO 3.

3. PERFORM DTC CONFIRMATION PROCEDURE

1. Start engine and warm it up to normal operating temperature.
2. Turn ignition switch OFF and wait at least 10 seconds.
3. Start engine and run it for at least 1 minute at idle speed.
4. Check 1st trip DTC.

Is 1st trip DTC detected?

- YES >> Proceed to [EC-356, "Diagnosis Procedure"](#).

## P0506 ISC SYSTEM

< DTC/CIRCUIT DIAGNOSIS >

[QR25DE]

NO >> INSPECTION END

### Diagnosis Procedure

INFOID:000000011278065

#### 1. CHECK DTC PRIORITY

If DTC P0506 is displayed with other DTC, first perform the trouble diagnosis for other DTC.

Is applicable DTC detected?

- YES >> Perform diagnosis of applicable. Refer to [EC-96, "DTC Index"](#).  
NO >> GO TO 2.

#### 2. CHECK INTAKE AIR LEAK

1. Start engine and let it idle.
2. Listen for an intake air leak after the mass air flow sensor.

Is intake air leak detected?

- YES >> Discover air leak location and repair.  
NO >> Replace ECM. Refer to [EC-502, "Removal and Installation"](#).

P0507 ISC SYSTEM

Description

INFOID:0000000011278066

The ECM controls the engine idle speed to a specified level through the fine adjustment of the air, which is let into the intake manifold, by operating the electric throttle control actuator. The operating of the throttle valve is varied to allow for optimum control of the engine idling speed. The crankshaft position sensor (POS) detects the actual engine speed and sends a signal to the ECM.

The ECM controls the electric throttle control actuator so that the engine speed coincides with the target value memorized in the ECM. The target engine speed is the lowest speed at which the engine can operate steadily. The optimum value stored in the ECM is determined by taking into consideration various engine conditions, such as during warming up, deceleration, and engine load (air conditioner, power steering and cooling fan operation, etc.).

DTC Description

INFOID:0000000011278067

DTC DETECTION LOGIC

DTC No.	CONSULT screen terms (Trouble diagnosis content)	DTC detecting condition
P0507	ISC SYSTEM (Idle air control system RPM higher than expected)	The idle speed is more than the target idle speed by 200 rpm or more.

POSSIBLE CAUSE

- Electric throttle control actuator
- Intake air leak
- PCV system

FAIL-SAFE

Not applicable

DTC CONFIRMATION PROCEDURE

1. CHECK DTC PRIORITY

If DTC P0507 is displayed with other DTC, first perform the trouble diagnosis for other DTC.

Is applicable DTC detected?

YES >> Perform diagnosis of applicable. Refer to [EC-96, "DTC Index"](#).

NO >> GO TO 2.

2. PRECONDITIONING

If DTC Confirmation Procedure has been previously conducted, always perform the following procedure before conducting the next test.

1. Turn ignition switch OFF and wait at least 10 seconds.
2. Turn ignition switch ON.
3. Turn ignition switch OFF and wait at least 10 seconds.

**If the target idle speed is out of the specified value, perform [EC-144, "Work Procedure"](#), before conducting DTC Confirmation Procedure.**

**TESTING CONDITION:**

- Before performing the following procedure, confirm that battery voltage is more than 11 V at idle.
- Always perform the test at a temperature above -10°C (14°F).

>> GO TO 3.

3. PERFORM DTC CONFIRMATION PROCEDURE

1. Start engine and warm it up to normal operating temperature.
2. Turn ignition switch OFF and wait at least 10 seconds.
3. Start engine and run it for at least 1 minute at idle speed.
4. Check 1st trip DTC.

Is 1st trip DTC detected?

# P0507 ISC SYSTEM

[QR25DE]

< DTC/CIRCUIT DIAGNOSIS >

- YES >> Proceed to [EC-358. "Diagnosis Procedure"](#).  
NO >> INSPECTION END

## Diagnosis Procedure

INFOID:0000000011278068

### 1. CHECK DTC PRIORITY

If DTC P0507 is displayed with other DTC, first perform the trouble diagnosis for other DTC.

Is applicable DTC detected?

- YES >> Perform diagnosis of applicable. Refer to [EC-96. "DTC Index"](#).  
NO >> GO TO 2.

### 2. CHECK PCV HOSE CONNECTION

Confirm that PCV hose is connected correctly.

Is the inspection result normal?

- YES >> GO TO 3.  
NO >> Repair or replace error-detected parts.

### 3. CHECK INTAKE AIR LEAK

1. Start engine and let it idle.
2. Listen for an intake air leak after the mass air flow sensor.

Is intake air leak detected?

- YES >> Discover air leak location and repair.  
NO >> Replace ECM. Refer to [EC-502. "Removal and Installation"](#).

# P050A, P050B, P050E COLD START CONTROL

< DTC/CIRCUIT DIAGNOSIS >

[QR25DE]

## P050A, P050B, P050E COLD START CONTROL

### Description

INFOID:0000000011278069

ECM controls ignition timing and engine idle speed when engine is started with pre-warming up condition. This control promotes the activation of three way catalyst by heating the catalyst and reduces emissions.

### DTC Description

INFOID:0000000011278070

### DTC DETECTION LOGIC

DTC No.	CONSULT screen terms (Trouble diagnosis content)	DTC detecting condition
P050A	COLD START CONTROL (Cold start idle air control system performance)	ECM does not control engine idle speed properly when engine is started with pre-warming up condition.
P050B	COLD START CONTROL (Cold start ignition timing performance)	ECM does not control ignition timing properly when engine is started with pre-warming up condition.
P050E	COLD START CONTROL (Cold start engine exhaust temperature too low)	The temperature of the catalyst inlet does not rise to the proper temperature when the engine is started with pre-warming up condition.

### POSSIBLE CAUSE

- Lack of intake air volume
- Fuel injection system
- ECM

### FAIL-SAFE

P050A

Traveling control mode (Accelerator angle variation control)

P050B, P050E

Not applicable

### DTC CONFIRMATION PROCEDURE

#### 1. CHECK DTC PRIORITY

If DTC P050A, P050B or P050E is displayed with other DTC, first perform the trouble diagnosis for other DTC.

Is applicable DTC detected?

YES >> Perform diagnosis of applicable. Refer to [EC-96, "DTC Index"](#).

NO >> GO TO 2.

#### 2. PRECONDITIONING

If DTC Confirmation Procedure has been previously conducted, always perform the following procedure before conducting the next test.

1. Turn ignition switch OFF and wait at least 10 seconds.
2. Turn ignition switch ON.
3. Turn ignition switch OFF and wait at least 10 seconds.

#### TESTING CONDITION:

**Before performing the following procedure, confirm that battery voltage is more than 11 V at idle.**

>> GO TO 3.

#### 3. PERFORM DTC CONFIRMATION PROCEDURE-1

##### With CONSULT

1. Turn ignition switch OFF and wait at least 10 seconds.
2. Turn ignition switch ON.
3. Select "DATA MONITOR" mode with CONSULT.
4. Check the indication of "COOLAN TEMP/S".

##### With GST

# P050A, P050B, P050E COLD START CONTROL

[QR25DE]

< DTC/CIRCUIT DIAGNOSIS >

Follow the procedure "With CONSULT" above.

Is the value of "COOLAN TEMP/S" between 15°C (59°F) and 36°C (97°F)?

YES >> GO TO 4.

NO-1 [If it is below 15°C (59°F)]>>Warm up the engine until the value of "COOLAN TEMP/S" reaches 15°C (59°F) or more. Retry from step 1.

NO-2 [If it is above 36°C (97°F)]>>Cool engine down to less than 36°C (97°F). Retry from step 1.

## 4.PERFORM DTC CONFIRMATION PROCEDURE-2

### With CONSULT

1. Set the select lever in N range.

2. Start the engine and warm up in idle with the value of "COOLAN TEMP/S" between 15°C (59°F) and 40°C (104°F) for more than 15 seconds.

3. Check 1st trip DTC.

### With GST

Follow the procedure "With CONSULT" above.

Is 1st trip DTC detected?

YES >> Proceed to [EC-360, "Diagnosis Procedure"](#).

NO >> INSPECTION END

## Diagnosis Procedure

INFOID:0000000011278071

### 1.CHECK DTC PRIORITY

If DTC P050A, P050B or P050E is displayed with other DTC, first perform the trouble diagnosis for other DTC.

Is applicable DTC detected?

YES >> Perform diagnosis of applicable. Refer to [EC-96, "DTC Index"](#).

NO >> GO TO 2.

### 2.PERFORM IDLE AIR VOLUME LEARNING

Perform [EC-144, "Work Procedure"](#).

Is Idle Air Volume Learning carried out successfully?

YES >> GO TO 3.

NO >> Follow the instruction of Idle Air Volume Learning.

### 3.CHECK INTAKE SYSTEM

Check for the cause of intake air volume lacking. Refer to the following.

- Crushed intake air passage
- Intake air passage clogging
- Clogging of throttle body

Is the inspection result normal?

YES >> GO TO 4.

NO >> Repair or replace malfunctioning part

### 4.CHECK FUEL INJECTION SYSTEM FUNCTION

Perform DTC Confirmation Procedure for DTC P0171. Refer to [EC-263, "DTC Description"](#).

Is the inspection result normal?

YES >> GO TO 5.

NO >> Proceed to [EC-264, "Diagnosis Procedure"](#) for DTC P0171.

### 5.PERFORM DTC CONFIRMATION PROCEDURE

1. Turn ignition switch ON.

2. Erase DTC.

3. Perform DTC Confirmation Procedure.

See [EC-359, "DTC Description"](#).

Is the 1st trip DTC P050A, P050B or P050E displayed again?

YES >> Replace ECM. Refer to [EC-502, "Removal and Installation"](#).

NO >> INSPECTION END



# P0520 EOP SENSOR

< DTC/CIRCUIT DIAGNOSIS >

[QR25DE]

## P0520 EOP SENSOR

### DTC Description

INFOID:0000000011278072

### DTC DETECTION LOGIC

DTC No.	CONSULT screen terms (Trouble diagnosis content)	DTC detecting condition
P0520	EOP SENSOR/SWITCH (Engine oil pressure sensor/switch circuit)	Signal voltage from the EOP sensor remains at more than 5.02 V / less than 0.3 V for 5 seconds or more.

### POSSIBLE CAUSE

- Harness or connectors (EOP sensor circuit is open or shorted.)
- Engine oil level abnormality
- EOP sensor
- Sensor power supply 2 circuit

### FAIL-SAFE

Not applicable

### DTC CONFIRMATION PROCEDURE

#### 1. PRECONDITIONING

If DTC Confirmation Procedure has been previously conducted, always perform the following procedure before conducting the next test.

1. Turn ignition switch OFF and wait at least 10 seconds.
2. Turn ignition switch ON.
3. Turn ignition switch OFF and wait at least 10 seconds.

>> GO TO 2.

#### 2. PERFORM DTC CONFIRMATION PROCEDURE

1. Turn ignition switch ON and wait at least 5 seconds.
2. Check 1st trip DTC.

#### Is 1st trip DTC detected?

- YES >> Proceed to [EC-361, "Diagnosis Procedure"](#).  
NO >> INSPECTION END

### Diagnosis Procedure

INFOID:0000000011278073

#### 1. CHECK ENGINE OIL

1. Turn ignition switch OFF.
2. Check engine oil level and pressure. Refer to [LU-7, "Inspection"](#).

#### Is inspection result normal?

- YES >> GO TO 2.  
NO >> Repair or replace error-detected parts.

#### 2. CHECK EOP SENSOR POWER SUPPLY-1

1. Disconnect EOP sensor connector.
2. Turn ignition switch ON.
3. Check the voltage between EOP sensor harness connector terminals.

Connector	EOP sensor		Voltage (Approx.)
	+	-	
F54	3	1	5 V

#### Inspection result normal?

# P0520 EOP SENSOR

[QR25DE]

## < DTC/CIRCUIT DIAGNOSIS >

- YES >> GO TO 7.  
NO >> GO TO 3.

### 3. CHECK EOP SENSOR POWER SUPPLY-2

Check the voltage between EOP sensor harness connector and the ground.

+		-	Voltage (Approx.)
EOP sensor			
Connector	Terminal	Ground	5 V
F54	3		

Is inspection result normal?

- YES >> GO TO 5.  
NO >> GO TO 4.

### 4. CHECK SENSOR POWER SUPPLY 2 CIRCUIT

Perform [EC-487. "Diagnosis Procedure"](#).

Is inspection result normal?

- YES >> Perform the trouble diagnosis for power supply circuit.  
NO >> Repair or replace error-detected parts.

### 5. CHECK EOP SENSOR GROUND CIRCUIT

1. Turn ignition switch OFF.
2. Disconnect ECM harness connector.
3. Check the continuity between EOP sensor harness connector and ECM harness connector.

+		-		Continuity
EOP sensor		ECM		
Connector	Terminal	Connector	Terminal	Existed
F54	1	F51	38	

4. Also check harness for short to power.

Is inspection result normal?

- YES >> GO TO 6.  
NO >> Repair or replace error-detected parts.

### 6. CHECK ECM GROUND CIRCUIT

Check the continuity between ECM harness connector and ground.

+		-	Continuity
ECM			
Connector	Terminal	Ground	Existed
F51	16		
F52	52		
E16	123		
	128		

Is inspection result normal?

- YES >> GO TO 9.  
NO >> Repair or replace error-detected parts.

### 7. CHECK EOP SENSOR SIGNAL CIRCUIT

1. Turn ignition switch OFF.
2. Disconnect ECM harness connector.
3. Check the continuity between EOP sensor harness connector and ECM harness connector.

# P0520 EOP SENSOR

< DTC/CIRCUIT DIAGNOSIS >

[QR25DE]

+		-		Continuity
EOP sensor		ECM		
Connector	Terminal	Connector	Terminal	
F54	2	F51	39	Existed

4. Also check harness for short to ground and to power.

Is inspection result normal?

YES >> GO TO 8.

NO >> Repair or replace error-detected parts.

## 8.CHECK EOP SENSOR

Refer to [EC-363, "Component Inspection"](#).

Is inspection result normal?

YES >> GO TO 9.

NO >> Repair or replace error-detected parts.

## 9.CHECK INTERMITTENT INCIDENT

Refer to [GI-44, "Intermittent Incident"](#).

>> INSPECTION END

## Component Inspection

INFOID:0000000011278074

## 1.CHECK EOP SENSOR

1. Turn ignition switch OFF.
2. Disconnect EOP sensor harness connector.
3. Check resistance between EOP sensor connector terminals.

EOP sensor		Condition	Resistance (kΩ)
+	-		
Terminal			
1	2	None	4 kΩ – 10 kΩ
	3		2 kΩ – 8 kΩ
2	1		4 kΩ – 10 kΩ
	3		1 kΩ – 3 kΩ
3	1		2 kΩ – 8 kΩ
	2		1 kΩ – 3 kΩ

Is the inspection result normal?

YES >> INSPECTION END.

NO >> Replace EOP sensor. Refer to [EC-14, "Component Parts Location"](#).

# P0524 ENGINE OIL PRESSURE

< DTC/CIRCUIT DIAGNOSIS >

[QR25DE]

## P0524 ENGINE OIL PRESSURE

### DTC Description

INFOID:000000011278075

### DTC DETECTION LOGIC

DTC No.	CONSULT screen terms (Trouble diagnosis content)	DTC detecting condition
P0524	ENGINE OIL PRESSURE (Engine oil pressure too low)	An EOP sensor signal voltage applied to ECM remains lower than the specified value continuously for 10 seconds or more when the engine speed is 1,000 rpm or more.

### POSSIBLE CAUSE

- Decrease in engine oil pressure
- Decrease in engine oil level
- Engine oil condition
- EOP sensor
- Engine body

### FAIL-SAFE

- ECM illuminates oil pressure warning lamp on the combination meter.
- Engine speed will not rise more than 4,000rpm due to the fuel cut.
- Fail-safe is canceled when ignition switch OFF → ON.

### DTC CONFIRMATION PROCEDURE

#### CAUTION:

If "[EC-365. "Diagnosis Procedure"](#) is unfinished, be sure to perform Step 3 and 4.

#### 1. PRECONDITIONING-1

If DTC Confirmation Procedure has been previously conducted, always perform the following procedure before conducting the next test.

1. Turn ignition switch OFF and wait at least 10 seconds.
2. Turn ignition switch ON.
3. Turn ignition switch OFF and wait at least 10 seconds.

#### TEST CONDITION:

Before performing the following procedure, confirm that battery voltage is 11 V or more at idle.

>> GO TO 2.

#### 2. PRECONDITIONING-2

Is "Diagnosis Procedure" of DTC P0524 finished?

- YES >> GO TO 3.  
NO >> GO TO 4.

#### 3. PERFORM DTC CONFIRMATION PROCEDURE

1. Start engine and warm it up to normal operating temperature.
2. Maintain the following conditions for about 10 consecutive seconds.

Selector lever	P or N position
Engine coolant temperature	70°C (158°F) or more
Engine speed	1,000 rpm or more

#### NOTE:

With engine speed set around 4,000 rpm, the phenomenon can be reproduced more easily.

3. Check 1st trip DTC.

Is 1st trip DTC detected?

- YES >> Proceed to [EC-365. "Diagnosis Procedure"](#).  
NO >> INSPECTION END

# P0524 ENGINE OIL PRESSURE

< DTC/CIRCUIT DIAGNOSIS >

[QR25DE]

## 4. CHECK ENGINE OIL LEVEL

Check engine oil pressure. Refer to [LU-7, "Inspection"](#).

Is the inspection result normal?

YES >> GO TO 5.

NO >> Proceed to [EC-365, "Diagnosis Procedure"](#).

## 5. CHECK ENGINE OIL PRESSURE

 With CONSULT

1. Turn ignition switch ON.
2. Select "DATA MONITOR" mode of "ENGINE" using CONSULT.
3. Start the engine and check that "EOP SENSOR" changes, according to engine speeds.

Monitor item	Condition	Value (Approx.)
EOP SENSOR	<ul style="list-style-type: none"><li>• Engine oil temperature: 80°C (176°F)</li><li>• Selector lever: P or N position</li><li>• Air conditioner switch: OFF</li><li>• No load</li></ul>	Engine speed: Idle 1,450 mV or more
		Engine speed: 2,000 rpm 2,850 mV or more

 Without CONSULT

Check engine oil level. Refer to [LU-7, "Inspection"](#).

Is the inspection result normal?

YES >> GO TO 3.

NO >> Proceed to [EC-365, "Diagnosis Procedure"](#).

## Diagnosis Procedure

INFOID:000000011278076

## 1. CHECK ENGINE OIL LEVEL

1. Turn ignition switch OFF.
2. Check engine oil pressure level. Refer to [LU-7, "Inspection"](#).

Is the inspection result normal?

YES >> GO TO 2.

NO >> GO TO 4.

## 2. CHECK ENGINE OIL PRESSURE

 With CONSULT

1. Turn ignition switch ON.
2. Select "DATA MONITOR" mode of "ENGINE" using CONSULT.
3. Start the engine and check that "EOP SENSOR" changes, according to engine speeds.

Monitor item	Condition	Value (Approx.)
EOP SENSOR	<ul style="list-style-type: none"><li>• Engine oil temperature: 80°C (176°F)</li><li>• Selector lever: P or N position</li><li>• Air conditioner switch: OFF</li><li>• No load</li></ul>	Engine speed: Idle 1,450 mV or more
		Engine speed: 2,000 rpm 2,850 mV or more

 Without CONSULT

Check engine oil pressure. Refer to [LU-7, "Inspection"](#).

Is the inspection result normal?

YES >> GO TO 3.

NO >> Check oil pump. Refer to [LU-15, "Inspection"](#).

## 3. CHECK EOP SENSOR

Check EOP sensor. Refer to [EC-363, "Component Inspection"](#).

Is the inspection result normal?

# P0524 ENGINE OIL PRESSURE

[QR25DE]

< DTC/CIRCUIT DIAGNOSIS >

- YES >> GO TO 6.  
 NO >> Repair or replace error-detected parts.

## 4.CHECK ENGINE OIL LEAKAGE

Check engine oil leakage. Refer to [LU-6, "Engine Lubrication System Schematic"](#).

Is the inspection result normal?

- YES >> GO TO 5.  
 NO >> Repair or replace error-detected parts.

## 5.CHECK CAUSE OF ENGINE OIL CONSUMPTION

Check the following item.

Step	Inspection item	Equipment	Standard	Reference
1	PCV valve	<a href="#">EC-501, "Inspection"</a>		
2	Exhaust front tube	Visual	<ul style="list-style-type: none"> <li>• No blocking</li> <li>• No abnormal sounds</li> </ul>	—
3	Oil pump	Visual	<ul style="list-style-type: none"> <li>• No blocking</li> <li>• No abnormal sounds</li> </ul>	—
		<a href="#">LU-15, "Inspection"</a>		
4	<ul style="list-style-type: none"> <li>• Piston</li> <li>• Piston pin</li> <li>• Piston ring</li> </ul>	<ul style="list-style-type: none"> <li>• Piston to piston pin oil clearance</li> <li>• Piston ring side clearance</li> <li>• Piston ring end gap</li> </ul>		<a href="#">EM-114, "How to Select Piston and Bearing"</a>
5	Cylinder block	<ul style="list-style-type: none"> <li>• Cylinder block top surface distortion</li> <li>• Piston to cylinder bore clearance</li> </ul>		<a href="#">EM-105, "Inspection"</a>

>> Repair or replace error-detected parts.

## 6.CHECK INTERMITTENT INCIDENT

Refer to [GI-44, "Intermittent Incident"](#).

>> INSPECTION END

## Component Inspection

INFOID:000000011278077

### 1.CHECK EOP SENSOR

1. Turn ignition switch OFF.
2. Disconnect EOP sensor harness connector.
3. Check resistance between EOP sensor connector terminals.

EOP sensor		Condition	Resistance (kΩ)	
+	-			
Terminal		None		
1	2			4 kΩ – 10 kΩ
	3			2 kΩ – 8 kΩ
2	1			4 kΩ – 10 kΩ
	3			1 kΩ – 3 kΩ
3	1			2 kΩ – 8 kΩ
	2	1 kΩ – 3 kΩ		

Is the inspection result normal?

- YES >> INSPECTION END.  
 NO >> Replace EOP sensor. Refer to [EC-14, "Component Parts Location"](#).

# P052A, P052B INTAKE VALVE TIMING CONTROL

< DTC/CIRCUIT DIAGNOSIS >

[QR25DE]

## P052A, P052B INTAKE VALVE TIMING CONTROL

### DTC Description

INFOID:0000000011278078

### DTC DETECTION LOGIC

DTC No.	CONSULT screen terms (Trouble diagnosis content)	DTC detecting condition
P052A	CAMSHAFT POSITION TIMING B1 (Cold start "A" camshaft position timing over-advanced bank 1)	There is a gap between angle of target and phase-control angle degree when the engine is in a cold condition.
P052B	CAMSHAFT POSITION TIMING B1 (Cold start "A" camshaft position timing over-retarded bank 1)	

### POSSIBLE CAUSE

- Crankshaft position sensor
- Camshaft position sensor
- Intake valve timing control solenoid valve
- Intake valve timing intermediate lock control solenoid valve
- Accumulation of debris to the signal pick-up portion of the camshaft
- Timing chain installation
- Foreign matter caught in the oil groove for intake valve timing control

### FAIL-SAFE

Device fix mode

### DTC CONFIRMATION PROCEDURE

#### 1. CHECK DTC PRIORITY

If DTC P052A or P052B is displayed with DTC P0075, first perform the trouble diagnosis for DTC P0075.

Is applicable DTC detected?

- YES >> Perform diagnosis of applicable. Refer to [EC-194, "DTC Description"](#).  
NO >> GO TO 2.

#### 2. PRECONDITIONING

##### TESTING CONDITION:

**Before performing the following procedure, confirm that battery voltage is 10 V or more at idle.**

##### With CONSULT

1. Turn ignition switch OFF and wait at least 10 seconds.
2. Turn ignition switch ON.
3. Turn ignition switch OFF and wait at least 10 seconds.
4. Turn ignition switch ON.
5. On the CONSULT screen, select "ENGINE" >> "DATA MONITOR" >> "COOLAN TEMP/S".
6. Check "COOLAN TEMP/S" indication value.

##### With GST

Follow the procedure "With CONSULT" above.

Is the value of "COOLAN TEMP/S" -5°C (23°F) and 45°C (113°F)?

- YES >> GO TO 3.  
NO-1 [if it is below -5°C (23°F)]>>Warm up the engine until the value of "COOLAN TEMP/S" indicates -5°C (23°F) and 45°C (113°F). And then GO TO 3.  
NO-2 [if it is above 45°C (113°F)]>>Cool the engine down to the value of "COOLAN TEMP/S" indicates -5°C (23°F) and 45°C (113°F). And then GO TO 3.

#### 3. PERFORM DTC CONFIRMATION PROCEDURE-I

1. Turn ignition switch OFF and wait at 10 seconds.
2. Turn ignition switch ON.
3. Set the selector lever in N range.
4. Start the engine and let it idle for 20 seconds or more.
5. Check 1st trip DTC.

# P052A, P052B INTAKE VALVE TIMING CONTROL

[QR25DE]

< DTC/CIRCUIT DIAGNOSIS >

Is 1st trip DTC detected?

- YES >> Proceed to [EC-368, "Diagnosis Procedure"](#)
- NO >> INSPECTION END

## Diagnosis Procedure

INFOID:000000011278079

### 1. CHECK DTC PRIORITY

If DTC P052A or P052B is displayed with DTC P0075, first perform the trouble diagnosis for DTC P0075.

Is applicable DTC detected?

- YES >> Perform diagnosis of applicable. Refer to [EC-194, "DTC Description"](#).
- NO >> GO TO 2.

### 2. INSPECTION START

- With CONSULT>>GO TO 3.
- Without CONSULT>>GO TO 4.

### 3. CHECK VTC POSITION

#### With CONSULT

1. Turn ignition switch ON.
2. On the CONSULT screen, select "ENGINE" >> "DATA MONITOR" >> "COOLAN TEMP/S".
3. Check that the "COOLAN TEMP/S" indication value is between  $-5^{\circ}\text{C}$  ( $23^{\circ}\text{F}$ ) and  $45^{\circ}\text{C}$  ( $113^{\circ}\text{F}$ ).
4. Start engine and wait at least 5 seconds.
5. On the CONSULT screen, select "ENGINE" >> "DATA MONITOR" >> "INT/V TIM (B1)".
6. Check that the data monitor item indicates as follows:

Item	Value ( $^{\circ}\text{CA}$ )
INT/V TIM (B1)	$10 \pm 2$

Is the inspection result normal?

- YES >> GO TO 12.
- NO >> GO TO 4.

### 4. CHECK OIL PRESSURE WARNING LAMP

1. Start engine.
2. Check that oil pressure warning lamp is not illuminated.

Is oil pressure warning lamp illuminated?

- YES >> Refer to [LU-7, "Inspection"](#).
- NO >> GO TO 5.

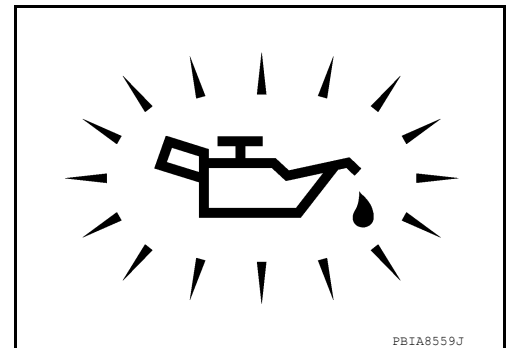

### 5. CHECK INTAKE VALVE TIMING INTERMEDIATE LOCK CONTROL SOLENOID VALVE

Perform Component Inspection of the intake valve timing intermediate lock control solenoid valve. Refer to [EC-370, "Component Inspection \(Intake Valve Timing Intermediate Lock Control Solenoid Valve\)"](#).

Is the inspection result normal?

- YES >> GO TO 6.
- NO >> Repair or replace error-detected parts.

### 6. CHECK INTAKE VALVE TIMING CONTROL SOLENOID VALVE

Perform Component Inspection of the intake valve timing control solenoid valve. Refer to [EC-369, "Component Inspection \(Intake Valve Timing Control Solenoid Valve\)"](#).



# P052A, P052B INTAKE VALVE TIMING CONTROL

[QR25DE]

< DTC/CIRCUIT DIAGNOSIS >

Is the inspection result normal?

- YES >> GO TO 7.
- NO >> Repair or replace error-detected parts.

## 7. CHECK CRANKSHAFT POSITION SENSOR

Perform Component Inspection of the crankshaft position sensor. Refer to [EC-371. "Component Inspection \(Crankshaft Position sensor\)"](#).

Is the inspection result normal?

- YES >> GO TO 8.
- NO >> Repair or replace error-detected parts.

## 8. CHECK CAMSHAFT POSITION SENSOR

Perform Component Inspection of the camshaft position sensor. Refer to [EC-371. "Component Inspection \(Camshaft position sensor\)"](#).

Is the inspection result normal?

- YES >> GO TO 9.
- NO >> Repair or replace error-detected parts.

## 9. CHECK CAMSHAFT (INTAKE)

Check the following.

1. Accumulation of debris on the signal plate of camshaft front end
2. Chipping signal plate of camshaft front end

Is the inspection result normal?

- YES >> GO TO 10.
- NO >> Remove debris and clean the signal plate of camshaft front end or replace camshaft. Refer to [EM-69. "Removal and Installation"](#).

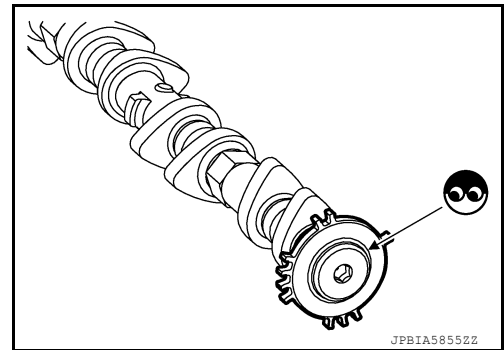

## 10. CHECK TIMING CHAIN INSTALLATION

Check service records for any recent repairs that may cause timing chain misalignment.

Are there any service records that may cause timing chain misalignment?

- YES >> Check timing chain installation. Refer to [EM-50. "Removal and Installation"](#).
- NO >> GO TO 11.

## 11. CHECK LUBRICATION CIRCUIT

Perform "Inspection of Camshaft Sprocket (INT) Oil Groove". Refer to [EM-77. "Inspection After Installation"](#).

Is the inspection result normal?

- YES >> GO TO 12.
- NO >> Clean lubrication line.

## 12. CHECK INTERMITTENT INCIDENT

Refer to [GI-44. "Intermittent Incident"](#).

>> INSPECTION END

## Component Inspection (Intake Valve Timing Control Solenoid Valve)

INFOID:0000000011278080

### 1. CHECK INTAKE VALVE TIMING CONTROL SOLENOID VALVE-I

1. Turn ignition switch OFF.
2. Disconnect intake valve timing control solenoid valve harness connector.
3. Check resistance between intake valve timing control solenoid valve terminals as per the following.

# P052A, P052B INTAKE VALVE TIMING CONTROL

< DTC/CIRCUIT DIAGNOSIS >

[QR25DE]

Terminals	Resistance
1 and 2	7.0 - 7.7 $\Omega$ [at 20°C (68°F)]
1 or 2 and ground	$\infty \Omega$ (Continuity should not exist)

Is the inspection result normal?

YES >> GO TO 2.

NO >> Replace malfunctioning intake valve timing control solenoid valve. Refer to [EM-49, "Exploded View"](#).

## 2. CHECK INTAKE VALVE TIMING CONTROL SOLENOID VALVE-II

1. Remove intake valve timing control solenoid valve. Refer to [EM-49, "Exploded View"](#).

2. Provide 12 V DC between intake valve timing control solenoid valve terminals 1 and 2, and then interrupt it. Check that the plunger moves as shown in the figure.

**CAUTION:**

**Never apply 12 V DC continuously for 5 seconds or more. Doing so may result in damage to the coil in intake valve timing control solenoid valve.**

**NOTE:**

**Always replace O-ring when intake valve timing control solenoid valve is removed.**

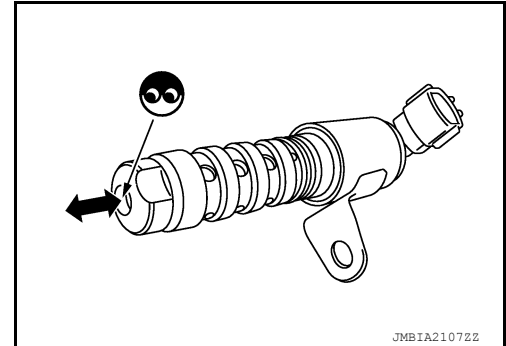

Is the inspection result normal?

YES >> INSPECTION END

NO >> Replace malfunctioning intake valve timing control solenoid valve. Refer to [EM-49, "Exploded View"](#).

## Component Inspection (Intake Valve Timing Intermediate Lock Control Solenoid Valve)

INFOID:000000011278081

## 1. CHECK INTAKE VALVE TIMING INTERMEDIATE LOCK CONTROL SOLENOID VALVE-I

1. Turn ignition switch OFF.

2. Disconnect intake valve timing intermediate lock control solenoid valve harness connector.

3. Check resistance between intake valve timing intermediate lock control solenoid valve terminals as per the following.

Terminals	Resistance
1 and 2	7.0 - 7.7 $\Omega$ [at 20°C (68°F)]
1 or 2 and ground	$\infty \Omega$ (Continuity should not exist)

Is the inspection result normal?

YES >> GO TO 2.

NO >> Replace malfunctioning intake valve timing intermediate lock control solenoid valve. Refer to [EM-49, "Exploded View"](#).

## 2. CHECK INTAKE VALVE TIMING INTERMEDIATE LOCK CONTROL SOLENOID VALVE-II

1. Remove intake valve timing intermediate lock control solenoid valve. Refer to [EM-49, "Exploded View"](#).

# P052A, P052B INTAKE VALVE TIMING CONTROL

[QR25DE]

## < DTC/CIRCUIT DIAGNOSIS >

- Provide 12 V DC between intake valve timing intermediate lock control solenoid valve terminals 1 and 2, and then interrupt it. Check that the plunger moves as shown in the figure.

**CAUTION:**

**Never apply 12 V DC continuously for 5 seconds or more. Doing so may result in damage to the coil in intake valve timing intermediate lock control solenoid valve.**

**NOTE:**

**Always replace O-ring when intake valve timing intermediate lock control solenoid valve is removed.**

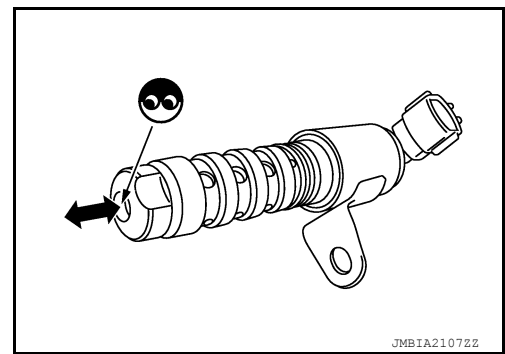

JMBIA2107ZZ

Is the inspection result normal?

YES >> INSPECTION END

NO >> Replace malfunctioning intake valve timing intermediate lock control solenoid valve. Refer to [EM-49, "Exploded View"](#).

## Component Inspection (Crankshaft Position sensor)

INFOID:0000000011278082

### 1. CHECK CRANKSHAFT POSITION SENSOR (POS)-1

- Turn ignition switch OFF.
- Loosen the fixing bolt of the sensor.
- Disconnect crankshaft position sensor (POS) harness connector.
- Remove the sensor.
- Visually check the sensor for chipping.

Is the inspection result normal?

YES >> GO TO 2.

NO >> Replace crankshaft position sensor (POS). Refer to [EM-97, "Exploded View"](#).

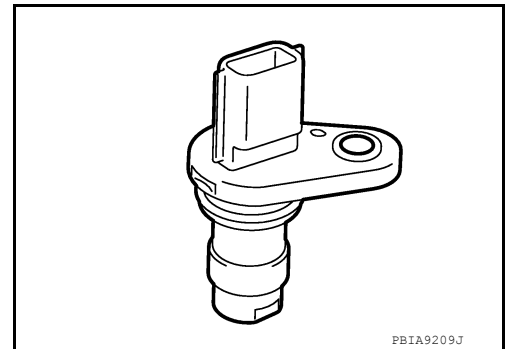

PBIA9209J

### 2. CHECK CRANKSHAFT POSITION SENSOR (POS)-2

Check the resistance between crankshaft position sensor (POS) terminals as per the following.

Crankshaft position sensor (POS)		Resistance [at 25°C (77°F)]
+	-	
Terminal (Polarity)		Except 0 or ∞ Ω
1	2	
	3	
2	3	

Is the inspection result normal?

YES >> INSPECTION END

NO >> Replace crankshaft position sensor (POS). Refer to [EM-97, "Exploded View"](#).

## Component Inspection (Camshaft position sensor)

INFOID:0000000011278083

### 1. CHECK CAMSHAFT POSITION SENSOR (PHASE)-1

- Turn ignition switch OFF.
- Loosen the fixing bolt of the sensor.
- Disconnect camshaft position sensor (PHASE) harness connector.
- Remove the sensor.

# P052A, P052B INTAKE VALVE TIMING CONTROL

[QR25DE]

< DTC/CIRCUIT DIAGNOSIS >

5. Visually check the sensor for chipping.

Is the inspection result normal?

YES >> GO TO 2.

NO >> Replace camshaft position sensor (PHASE).

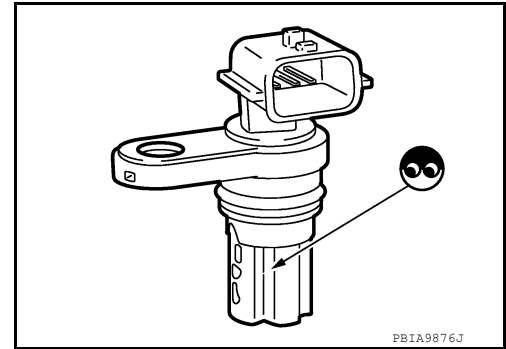

## 2. CHECK CAMSHAFT POSITION SENSOR (PHASE)-2

Check the resistance camshaft position sensor (PHASE) terminals as per the following.

Camshaft position sensor (PHASE)		Resistance [ $\Omega$ at 25°C (77°F)]
+	-	
Terminals (Polarity)		Except 0 or $\infty$
1	2	
	3	
2	3	

Is the inspection result normal?

YES >> INSPECTION END

NO >> Replace camshaft position sensor (PHASE). Refer to [EM-69. "Removal and Installation"](#).

P0603, P062F ECM

DTC Description

INFOID:0000000011278084

DTC DETECTION LOGIC

DTC No.	CONSULT screen terms (Trouble diagnosis content)	DTC detecting condition
P0603	ECM BACK UP/CIRCUIT [Internal Control Module Keep Alive Memory (KAM) Error]	ECM buck up system does not function properly.
P062F	CONTROL MODULE (Internal control module EEPROM error)	EEPROM (built-in microcomputer) system internal ECM does not function properly.

POSSIBLE CAUSE

DTC P0603

- Harness or connectors (ECM power supply circuit is open or shorted.)
- ECM

DTC P062F

ECM

FAIL-SAFE

Not applicable

DTC CONFIRMATION PROCEDURE

1. PRECONDITIONING

Perform the following procedure before performing DTC Confirmation Procedure.

1. Turn ignition switch OFF and wait at least 10 seconds.
2. Turn ignition switch ON.
3. Turn ignition switch OFF and wait at least 10 seconds.

>> GO TO 2.

2. PERFORM DTC CONFIRMATION PROCEDURE FOR DTC P062F

1. Start engine and wait at least 10 seconds.
2. Turn ignition switch OFF and wait at least 10 seconds.
3. Repeat steps 1 and 2 for 4 times.
4. Turn ignition switch ON.
5. Erase DTC.
6. Turn ignition switch OFF and wait at least 10 seconds.
7. Start engine and wait at least 10 seconds.
8. Check 1st trip DTC.

Is 1st trip DTC detected?

- YES >> Proceed to [EC-374, "Diagnosis Procedure"](#).  
 NO >> GO TO 3.

3. PERFORM DTC CONFIRMATION PROCEDURE FOR DTC P0603

1. Turn ignition switch OFF and wait at least 10 seconds.
2. Turn ignition switch ON and wait at least 10 seconds.
3. Turn ignition switch OFF and wait at least 5 minutes.
4. Turn ignition switch ON and wait at least 10 seconds.
5. Repeat steps 3 and 4 for 5 times.
6. Turn ignition switch ON.
7. Check 1st trip DTC.

Is 1st trip DTC detected?

- YES >> Proceed to [EC-374, "Diagnosis Procedure"](#).  
 NO >> INSPECTION END

## Diagnosis Procedure

INFOID:000000011278085

### 1.INSPECTION START

Check that the battery negative terminal is not disconnected during ignition switch ON.

Is the inspection result normal?

YES >> GO TO 3.

NO >> GO TO 2.

### 2.ERASE DTC

1. Start the engine and let it idle at least 10 seconds.
2. Turn ignition switch OFF.
3. Repeat steps 1 and 2 for 4 times.
4. Erase DTC.
5. Turn ignition switch OFF and wait at least 10 seconds.
6. Start the engine and let it idle for 10 seconds.
7. Check 1st trip DTC.

Is DTC P062F detected again?

YES >> Replace ECM. Refer to [EC-502, "Removal and Installation"](#).

NO >> INSPECTION END

### 3.CHECK ECM POWER SUPPLY AND GROUND CIRCUIT

Check ECM power supply and ground circuit. Refer to [EC-168, "Diagnosis Procedure"](#).

Is the inspection result normal?

YES >> GO TO 4.

NO >> Repair or replace error-detected parts.

### 4.CHECK INTERMITTENT INCIDENT

Check intermittent incident. Refer to [GI-44, "Intermittent Incident"](#).

Is the inspection result normal?

YES >> GO TO 5.

NO >> Repair or replace error-detected parts.

### 5.PERFORM DTC CONFIRMATION PROCEDURE

1. Turn ignition switch ON.
2. Erase DTC.
3. Perform DTC confirmation procedure. Refer to [EC-373, "DTC Description"](#).

Is the DTC P0603 or P062F detected again?

YES >> Replace ECM. Refer to [EC-502, "Removal and Installation"](#).

NO >> INSPECTION END

# P0604 ECM

< DTC/CIRCUIT DIAGNOSIS >

[QR25DE]

## P0604 ECM

### DTC Description

INFOID:0000000011278086

### DTC DETECTION LOGIC

DTC No.	CONSULT screen terms (Trouble diagnosis content)	DTC detecting condition
P0604	ECM [Internal control module random access memory (RAM) error]	Malfunction in the internal RAM of ECM.

### POSSIBLE CAUSE

ECM

### FAIL-SAFE

Not applicable

### DTC CONFIRMATION PROCEDURE

#### 1. PRECONDITIONING

1. Turn ignition switch OFF and wait at least 10 seconds.
2. Turn ignition switch ON.
3. Turn ignition switch OFF and wait at least 10 seconds.

#### TESTING CONDITION:

**Before performing the following procedure, confirm that battery voltage is 11 V or more with ignition switch ON.**

>> GO TO 2.

#### 2. PERFORM DTC CONFIRMATION PROCEDURE

1. Turn ignition switch ON (engine stopped) and wait least 20 minutes.

#### CAUTION:

**Never start engine during this procedure.**

2. Turn ignition switch OFF and wait at least 10 seconds.
3. Turn ignition switch ON.
4. Check 1st trip DTC.

#### Is 1st trip DTC detected?

- YES >> Proceed to [EC-375, "Diagnosis Procedure"](#).  
NO >> INSPECTION END

### Diagnosis Procedure

INFOID:0000000011278087

#### 1. PERFORM DTC CONFIRMATION PROCEDURE

1. Turn ignition switch ON.
2. Erase DTC.
3. Perform DTC confirmation procedure. Refer to [EC-375, "DTC Description"](#).

#### Is the 1st trip DTC P0604 displayed again?

- YES >> Replace ECM. Refer to [EC-502, "Removal and Installation"](#).  
NO >> INSPECTION END

# P0605 ECM

< DTC/CIRCUIT DIAGNOSIS >

[QR25DE]

## P0605 ECM

### DTC Description

INFOID:000000011278088

### DTC DETECTION LOGIC

DTC No.	CONSULT screen terms (Trouble diagnosis content)	DTC detecting condition
P0605	ECM [Internal control module read only memory (ROM) error]	Malfunction in the internal ROM of ECM.

### POSSIBLE CAUSE

ECM

### FAIL-SAFE

Traveling control mode (Engine output control)

### DTC CONFIRMATION PROCEDURE

#### 1. PRECONDITIONING

1. Turn ignition switch OFF and wait at least 10 seconds.
2. Turn ignition switch ON.
3. Turn ignition switch OFF and wait at least 10 seconds.

#### TESTING CONDITION:

**Before performing the following procedure, confirm that battery voltage is 11 V or more with ignition switch ON.**

>> GO TO 2.

#### 2. PERFORM DTC CONFIRMATION PROCEDURE

1. Turn ignition switch ON (engine stopped) and wait least 20 minutes.

#### CAUTION:

**Never start engine during this procedure.**

2. Turn ignition switch OFF and wait at least 10 seconds.
3. Turn ignition switch ON.
4. Check 1st trip DTC.

#### Is 1st trip DTC detected?

- YES >> Proceed to [EC-376, "Diagnosis Procedure"](#).  
NO >> INSPECTION END

### Diagnosis Procedure

INFOID:000000011278089

#### 1. PERFORM DTC CONFIRMATION PROCEDURE

1. Turn ignition switch ON.
2. Erase DTC.
3. Perform DTC confirmation procedure. Refer to [EC-375, "DTC Description"](#).

#### Is the 1st trip DTC P0605 displayed again?

- YES >> Replace ECM. Refer to [EC-502, "Removal and Installation"](#).  
NO >> INSPECTION END



P0606 ECM

DTC Description

INFOID:000000011278090

DTC DETECTION LOGIC

DTC No.	CONSULT screen terms (Trouble diagnosis content)	DTC detecting condition
P0606	CONTROL MODULE (Control module processor)	Malfunction in ECM processor.

POSSIBLE CAUSE

ECM

FAIL-SAFE

Not applicable

DTC CONFIRMATION PROCEDURE

1. PRECONDITIONING

1. Turn ignition switch OFF and wait at least 10 seconds.
2. Turn ignition switch ON.
3. Turn ignition switch OFF and wait at least 10 seconds.

TESTING CONDITION:

Before performing the following procedure, confirm that battery voltage is 11 V or more with ignition switch ON.

>> GO TO 2.

2. PERFORM DTC CONFIRMATION PROCEDURE-I

1. Turn ignition switch ON (engine stopped) and wait at least 10 seconds.

**CAUTION:**

**Never start engine during this procedure.**

2. Turn ignition switch OFF and wait at least 10 seconds.
3. Turn ignition switch ON.
4. Check 1st trip DTC.

Is 1st trip DTC detected?

YES >> Proceed to [EC-377, "Diagnosis Procedure"](#).

NO >> GO TO 3.

3. PERFORM DTC CONFIRMATION PROCEDURE-II

1. Start engine.
2. Rev up the engine quickly to approximately 3,000 rpm under unloaded condition and completely release the accelerator pedal.
3. Let the engine idle and wait at least 10 seconds.
4. Turn ignition switch OFF and wait at least 10 seconds.
5. Turn ignition switch ON.
6. Check 1st trip DTC.

Is 1st trip DTC detected?

YES >> Proceed to [EC-377, "Diagnosis Procedure"](#).

NO >> INSPECTION END

Diagnosis Procedure

INFOID:000000011278091

1. PERFORM DTC CONFIRMATION PROCEDURE

1. Turn ignition switch ON.
2. Erase DTC.
3. Perform DTC confirmation procedure for 3 times. Refer to [EC-377, "DTC Description"](#).

Is the 1st trip DTC P0606 displayed again?

## P0606 ECM

< DTC/CIRCUIT DIAGNOSIS >

[QR25DE]

---

YES >> Replace ECM. Refer to [EC-502. "Removal and Installation"](#).  
NO >> INSPECTION END

P0607 ECM

DTC Description

INFOID:0000000011278092

DTC DETECTION LOGIC

DTC No.	CONSULT screen terms (Trouble diagnosis content)	DTC detecting condition
P0607	ECM (Control module performance)	ECM internal communication system is malfunctioning.

POSSIBLE CAUSE

ECM

FAIL-SAFE

Not applicable

DTC CONFIRMATION PROCEDURE

1. PRECONDITIONING

1. Turn ignition switch OFF and wait at least 10 seconds.
2. Turn ignition switch ON.
3. Turn ignition switch OFF and wait at least 10 seconds.

**TESTING CONDITION:**

**Before performing the following procedure, confirm that battery voltage is 11 V or more with ignition switch ON.**

>> GO TO 2.

2. PERFORM DTC CONFIRMATION PROCEDURE

1. Turn ignition switch ON (engine stopped) and wait at least 10 seconds.
2. Turn ignition switch OFF and wait at least 10 seconds.
3. Turn ignition switch ON.
4. Check 1st trip DTC.

Is 1st trip DTC detected?

- YES >> Proceed to [EC-379, "Diagnosis Procedure"](#).
- NO >> INSPECTION END

Diagnosis Procedure

INFOID:0000000011278093

1. PERFORM DTC CONFIRMATION PROCEDURE

1. Turn ignition switch ON.
2. Erase DTC.
3. Perform DTC confirmation procedure. Refer to [EC-375, "DTC Description"](#).

Is the 1st trip DTC P0607 displayed again?

- YES >> Replace ECM. Refer to [EC-502, "Removal and Installation"](#).
- NO >> INSPECTION END

P060A ECM

DTC Description

INFOID:000000011278094

DTC DETECTION LOGIC

DTC No.	CONSULT screen terms (Trouble diagnosis content)	DTC detecting condition
P060A	CONTROL MODULE (Internal control module monitoring processor performance)	ECM internal monitoring processor is malfunctioning.

POSSIBLE CAUSE

ECM

FAIL-SAFE

Not applicable

DTC CONFIRMATION PROCEDURE

1. PRECONDITIONING

1. Turn ignition switch OFF and wait at least 10 seconds.
2. Turn ignition switch ON.
3. Turn ignition switch OFF and wait at least 10 seconds.

**TESTING CONDITION:**

**Before performing the following procedure, confirm that battery voltage is 11 V or more with ignition switch ON.**

>> GO TO 2.

2. PERFORM DTC CONFIRMATION PROCEDURE

1. Start engine and wait at least 10 seconds.
2. Turn ignition switch OFF and wait at least 10 seconds.
3. Repeat step 1 and 2 for 5 times.
4. Turn ignition switch ON.
5. Check 1st trip DTC.

Is 1st trip DTC detected?

- YES >> Proceed to [EC-380, "Diagnosis Procedure"](#).
- NO >> INSPECTION END

Diagnosis Procedure

INFOID:000000011278095

1. PERFORM DTC CONFIRMATION PROCEDURE

1. Turn ignition switch ON.
2. Erase DTC.
3. Perform DTC confirmation procedure. Refer to [EC-380, "DTC Description"](#).

Is the 1st trip DTC P060A displayed again?

- YES >> Replace ECM. Refer to [EC-502, "Removal and Installation"](#).
- NO >> INSPECTION END

P060B ECM

DTC Description

INFOID:000000011278096

DTC DETECTION LOGIC

DTC No.	CONSULT screen terms (Trouble diagnosis content)	DTC detecting condition
P060B	CONTROL MODULE (Internal control module A/D processing performance)	ECM internal analog/digital conversion processing system is malfunctioning.

POSSIBLE CAUSE

ECM

FAIL-SAFE

Not applicable

DTC CONFIRMATION PROCEDURE

1. PRECONDITIONING

1. Turn ignition switch OFF and wait at least 10 seconds.
2. Turn ignition switch ON.
3. Turn ignition switch OFF and wait at least 10 seconds.

**TESTING CONDITION:**

**Before performing the following procedure, confirm that battery voltage is 11 V or more with ignition switch ON.**

>> GO TO 2.

2. PERFORM DTC CONFIRMATION PROCEDURE

1. Turn ignition switch ON (engine stopped) and wait at least 10 seconds.
2. Turn ignition switch OFF and wait at least 10 seconds.
3. Turn ignition switch ON.
4. Check 1st trip DTC.

Is 1st trip DTC detected?

- YES >> Proceed to [EC-381, "Diagnosis Procedure"](#).
- NO >> INSPECTION END

Diagnosis Procedure

INFOID:000000011278097

1. PERFORM DTC CONFIRMATION PROCEDURE

1. Turn ignition switch ON.
2. Erase DTC.
3. Perform DTC confirmation procedure. Refer to [EC-381, "DTC Description"](#).

Is the 1st trip DTC P060B displayed again?

- YES >> Replace ECM. Refer to [EC-502, "Removal and Installation"](#).
- NO >> INSPECTION END

# P0643 SENSOR POWER SUPPLY

< DTC/CIRCUIT DIAGNOSIS >

[QR25DE]

## P0643 SENSOR POWER SUPPLY

### Description

INFOID:000000011278098

ECM supplies a voltage of 5 V to some of the sensors systematically divided into 2 groups, respectively. Accordingly, when a short circuit develops in a sensor power source, a malfunction may occur simultaneously in the sensors belonging to the same group as the short-circuited sensor.

Sensor power supply 1

- APP sensor 1
- CKP sensor (POS)
- Intake manifold runner control valve position sensor
- Refrigerant pressure sensor
- TP sensor

#### NOTE:

If sensor power supply 1 circuit is malfunctioning, DTC P0643 is displayed.

Sensor power supply 2

- APP sensor 2
- CMP sensor (PHASE)
- EVT control position sensor
- EOP sensor
- MAF sensor

### DTC Description

INFOID:000000011278099

### DTC DETECTION LOGIC

DTC No.	CONSULT screen terms (Trouble diagnosis content)	DTC detecting condition
P0643	SENSOR POWER/CIRC (Sensor reference voltage "A" circuit high)	ECM detects that the voltage of sensor power supply 1 is excessively low or high.

### POSSIBLE CAUSE

- Harness or connectors
- APP sensor 1 circuit is shorted.
- CKP sensor (POS) circuit is shorted.
- Intake manifold runner control valve position sensor circuit is shorted.
- TP sensor circuit is shorted.
- Refrigerant pressure sensor circuit is shorted.
- Accelerator pedal position sensor
- CKP sensor (POS)
- Intake manifold runner control valve position sensor
- Throttle position sensor
- Refrigerant pressure sensor

### FAIL-SAFE

ECM stops the electric throttle control actuator control, throttle valve is maintained at a fixed opening (approx. 5 degrees) by the return spring.

### DTC CONFIRMATION PROCEDURE

#### 1. PRECONDITIONING

If DTC Confirmation Procedure has been previously conducted, always perform the following procedure before conducting the next test.

1. Turn ignition switch OFF and wait at least 10 seconds.
2. Turn ignition switch ON.
3. Turn ignition switch OFF and wait at least 10 seconds.

#### TESTING CONDITION:

Before performing the following procedure, confirm that battery voltage is more than 10 V at idle.

# P0643 SENSOR POWER SUPPLY

[QR25DE]

< DTC/CIRCUIT DIAGNOSIS >

>> GO TO 2.

## 2. PERFORM DTC CONFIRMATION PROCEDURE

1. Start engine and let it idle for 1 second.
2. Check DTC.

Is DTC detected?

- YES >> Refer to [EC-383, "Diagnosis Procedure"](#).  
NO >> INSPECTION END

## Diagnosis Procedure

INFOID:0000000011278100

### 1. CHECK GROUND CONNECTION

1. Turn ignition switch OFF.
2. Check ground connection E9 and E15. Refer to Ground Inspection in [GI-46, "Circuit Inspection"](#).

Is the inspection result normal?

- YES >> GO TO 2.  
NO >> Repair or replace ground connection.

### 2. CHECK ACCELERATOR PEDAL POSITION SENSOR 1 POWER SUPPLY CIRCUIT

1. Disconnect accelerator pedal position (APP) sensor harness connector.
2. Turn ignition switch ON.
3. Check the voltage between APP sensor harness connector and ground.

+		-	Voltage (Approx.)
APP sensor			
Connector	Terminal		
E25	4	Ground	5 V

Is the inspection result normal?

- YES >> GO TO 5.  
NO >> GO TO 3.

### 3. CHECK SENSOR POWER SUPPLY CIRCUITS

Check harness for short to power and short to ground, between the following terminals.

ECM		Sensor		
Connector	Terminal	Name	Connector	Terminal
F52	72	CKP sensor (POS)	F17	1
	80	Electric throttle control actuator	F50	2
	84	Intake manifold runner control valve position sensor	F20	1
E16	104	Refrigerant pressure sensor	F10	3
	122	APP sensor	E25	4

Is the inspection result normal?

- YES >> GO TO 4.  
NO >> Repair short to ground or short to power in harness or connectors.

### 4. CHECK COMPONENTS

Check the following.

- Crankshaft position sensor (POS) (Refer to [EC-300, "Component Inspection \(Crankshaft Position sensor\)"](#).)
- Intake manifold runner control valve position sensor (Refer to [EC-427, "Diagnosis Procedure"](#).)
- Refrigerant pressure sensor (Refer to [EC-485, "Diagnosis Procedure"](#).)
- TP sensor (Refer to [EC-221, "Component Inspection"](#).)

Is the inspection result normal?

- YES >> GO TO 5.

## P0643 SENSOR POWER SUPPLY

[QR25DE]

< DTC/CIRCUIT DIAGNOSIS >

---

NO >> Repair or replace malfunctioning component.

### 5.CHECK APP SENSOR

---

Refer to [EC-445, "Component Inspection"](#).

Is the inspection result normal?

YES >> GO TO 6.

NO >> Replace accelerator pedal assembly. Refer to [ACC-3, "Removal and Installation"](#).

### 6.CHECK INTERMITTENT INCIDENT

---

Refer to [GI-44, "Intermittent Incident"](#).

>> INSPECTION END



# P0850 PNP SWITCH

< DTC/CIRCUIT DIAGNOSIS >

[QR25DE]

## P0850 PNP SWITCH

### Description

INFOID:0000000011278101

Transmission range switch is turn ON when the selector lever is P or N.  
ECM detects the position because the continuity of the line (the ON) exists.

### DTC Description

INFOID:0000000011278102

### DTC DETECTION LOGIC

DTC No.	CONSULT screen terms (Trouble diagnosis content)	DTC detecting condition
P0850	P-N POS SW/CIRCUIT (Park/neutral switch input circuit)	The signal of transmission range switch is not changed in the process of engine starting and driving.

### POSSIBLE CAUSE

- Harness or connectors (The transmission range switch circuit is open or shorted.)
- Transmission range switch

### FAIL-SAFE

Not applicable

### DTC CONFIRMATION PROCEDURE

#### 1.INSPECTION START

Do you have CONSULT?

Do you have CONSULT?

YES >> GO TO 2.

NO >> GO TO 5.

#### 2.PRECONDITIONING

If DTC Confirmation Procedure has been previously conducted, always perform the following procedure before conducting the next test.

1. Turn ignition switch OFF and wait at least 10 seconds.
2. Turn ignition switch ON.
3. Turn ignition switch OFF and wait at least 10 seconds.

>> GO TO 3.

#### 3.CHECK PNP SIGNAL FUNCTION

ⓂWith CONSULT

1. Turn ignition switch ON.
2. Select "P/N POSI SW" in "DATA MONITOR" mode of "ENGINE" using CONSULT. Then check the "P/N POSI SW" signal as per the following conditions.

Selector lever position	Known-good signal
N or P position	ON
Except above position	OFF

Is the inspection result normal?

YES >> GO TO 4.

NO >> Proceed to [EC-386, "Diagnosis Procedure"](#).

#### 4.PERFORM DTC CONFIRMATION PROCEDURE

1. Select "DATA MONITOR" mode of "ENGINE" using CONSULT.
2. Start engine and warm it up to normal operating temperature.
3. Maintain the following conditions for at least 60 consecutive seconds.

**CAUTION:**

# P0850 PNP SWITCH

< DTC/CIRCUIT DIAGNOSIS >

[QR25DE]

**Always drive vehicle at a safe speed.**

ENG SPEED	1,000 - 6,375 rpm
COOLAN TEMP/S	More than 65°C (149°F)
B/FUEL SCHDL	3.25 - 31.8 msec
VHCL SPEED SE	More than 64 km/h (40 mph)
Selector lever	Suitable position

4. Check 1st trip DTC.

Is 1st trip DTC detected?

YES >> Proceed to [EC-386, "Diagnosis Procedure"](#).

NO >> INSPECTION END

## 5.PERFORM COMPONENT FUNCTION CHECK

- Turn ignition switch ON.
- Check the voltage between ECM harness connector terminals as per the following conditions.

ECM			Condition	Voltage (Approx.)
Connector	+	-		
Terminal				
E16	117	128	Selector lever	P or N
				Except above
				Battery voltage
				0 V

Is the inspection result normal?

YES >> INSPECTION END

NO >> Proceed to [EC-386, "Diagnosis Procedure"](#).

## Diagnosis Procedure

INFOID:000000011278103

### 1.CHECK TRANSMISSION RANGE SWITCH POWER SUPPLY

- Turn ignition switch OFF.
- Disconnect transmission range switch harness connector.
- Turn ignition switch ON.
- Check the voltage between transmission range switch harness connector and ground.

+		-	Voltage
Transmission range switch			
Connector	Terminal		
F78	7	Ground	Battery voltage

Is the inspection result normal?

YES >> GO TO 3.

NO >> GO TO 2.

### 2.CHECK TRANSMISSION RANGE SWITCH POWER SUPPLY CIRCUIT

- Turn ignition switch OFF.
- Disconnect IPDM E/R harness connector.
- Check the continuity between transmission range switch harness connector and IPDM E/R harness connector.

+		-		Continuity
Transmission range switch		IPDM E/R		
Connector	Terminal	Connector	Terminal	
F78	7	F35	70	Existed

# P0850 PNP SWITCH

[QR25DE]

< DTC/CIRCUIT DIAGNOSIS >

4. Also check harness for short to ground.

Is the inspection result normal?

YES >> Perform the trouble diagnosis for power supply circuit.

NO >> Repair or replace error-detected parts.

## 3.CHECK TRANSMISSION RANGE SWITCH SIGNAL CIRCUIT

1. Turn ignition switch OFF.

2. Disconnect ECM harness connector.

3. Check the continuity between transmission range switch harness connector and ECM harness connector.

+		-		Continuity
Transmission range switch		ECM		
Connector	Terminal	Connector	Terminal	
F78	10	E16	117	Existed

4. Also check harness for short to ground and to power.

Is the inspection result normal?

YES >> GO TO 4.

NO >> Repair or replace error-detected parts.

## 4.CHECK TRANSMISSION RANGE SWITCH

Check the transmission range switch. Refer to [TM-110, "Component Inspection"](#).

Is the inspection result normal?

YES >> GO TO 5.

NO >> Replace transmission range switch. Refer to [TM-220, "Removal and Installation"](#).

## 5.CHECK INTERMITTENT INCIDENT

Refer to [GI-44, "Intermittent Incident"](#).

>> INSPECTION END

# P1078 EVT CONTROL POSITION SENSOR

< DTC/CIRCUIT DIAGNOSIS >

[QR25DE]

## P1078 EVT CONTROL POSITION SENSOR

### DTC Description

INFOID:000000011278104

### DTC DETECTION LOGIC

DTC No.	CONSULT screen terms (Trouble diagnosis content)	DTC detecting condition
P1078	EXH TIM SEN/CIRC-B1 (EXH TIM SEN/CIRC-B1)	An excessively high or low voltage from the sensor is sent to ECM.

### POSSIBLE CAUSE

- Harness or connectors (Exhaust valve timing control position sensor circuit is open or shorted.)
- Accumulation of debris to the signal pick-up portion of the camshaft
- Exhaust valve timing control position sensor
- Sensor power supply 2 circuit

### FAIL-SAFE

- Traveling control mode (Accelerator angle variation control)
- Device fix mode

### DTC CONFIRMATION PROCEDURE

#### 1. PRECONDITIONING

If DTC Confirmation Procedure has been previously conducted, always perform the following procedure before conducting the next test.

1. Turn ignition switch OFF and wait at least 10 seconds.
2. Turn ignition switch ON.
3. Turn ignition switch OFF and wait at least 10 seconds.

>> GO TO 2.

#### 2. PERFORM DTC CONFIRMATION PROCEDURE

1. Start engine and let it idle for 10 seconds.
2. Check 1st trip DTC.

#### Is 1st trip DTC detected?

- YES >> Proceed to [EC-388, "Diagnosis Procedure"](#).  
NO >> INSPECTION END

### Diagnosis Procedure

INFOID:000000011278105

#### 1. CHECK EXHAUST VALVE TIMING (EVT) CONTROL POSITION SENSOR POWER SUPPLY

1. Turn ignition switch OFF.
2. Disconnect exhaust valve timing (EVT) control position sensor harness connector.
3. Turn ignition switch ON.
4. Check the voltage between EVT control position sensor harness connector and ground.

+		-	Voltage (Approx.)
Connector	Terminal		
F45	1	Ground	5 V

#### Is the inspection result normal?

- YES >> GO TO 3.  
NO >> GO TO 2.

#### 2. CHECK SENSOR POWER SUPPLY 2 CIRCUIT

Perform [EC-487, "Diagnosis Procedure"](#).

# P1078 EVT CONTROL POSITION SENSOR

[QR25DE]

< DTC/CIRCUIT DIAGNOSIS >

Is inspection result normal?

YES >> Perform the trouble diagnosis for power supply circuit.

NO >> Repair or replace error-detected parts.

## 3.CHECK EVT CONTROL POSITION SENSOR GROUND CIRCUIT

1. Turn ignition switch OFF.
2. Disconnect ECM harness connector.
3. Check the continuity between EVT control position sensor harness connector and ECM harness connector.

+		-		Continuity
EVT control position sensor		ECM		
Connector	Terminal	Connector	Terminal	
F45	2	F51	42	Existed

4. Also check harness for short to power.

Is the inspection result normal?

YES >> GO TO 4.

NO >> Repair or replace error-detected parts.

## 4.CHECK EVT CONTROL POSITION SENSOR INPUT SIGNAL CIRCUIT

1. Disconnect ECM harness connector.
2. Check the continuity between EVT control position sensor harness connector and ECM harness connector.

+		-		Continuity
EVT control position sensor		ECM		
Connector	Terminal	Connector	Terminal	
F45	3	F51	43	Existed

3. Also check harness for short to ground and to power.

Is the inspection result normal?

YES >> GO TO 5.

NO >> Repair or replace error-detected parts.

## 5.CHECK EVT CONTROL POSITION SENSOR

Check the EVT control position sensor. Refer to [EC-390, "Component Inspection"](#).

Is the inspection result normal?

YES >> GO TO 6.

NO >> Replace EVT control position sensor. Refer to [EM-69, "Exploded View"](#).

## 6.CHECK CAMSHAFT (EXT)

Check the following.

- Accumulation of debris to the signal plate of camshaft rear end
- Chipping signal plate of camshaft rear end

Is the inspection result normal?

YES >> GO TO 7.

NO >> Remove debris and clean the signal plate of camshaft rear end or replace camshaft. Refer to [EM-69, "Removal and Installation"](#).

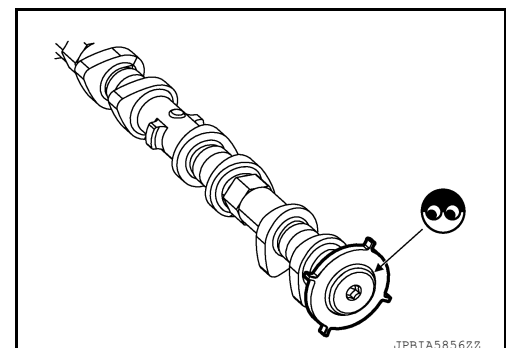

## 7.CHECK INTERMITTENT INCIDENT

Refer to [GI-44, "Intermittent Incident"](#).

# P1078 EVT CONTROL POSITION SENSOR

< DTC/CIRCUIT DIAGNOSIS >

[QR25DE]

>> INSPECTION END

## Component Inspection

INFOID:000000011278106

### 1. EXHAUST VALVE TIMING (EVT) CONTROL POSITION SENSOR-1

1. Turn ignition switch OFF.
2. Disconnect EVT control position sensor harness connector.
3. Loosen the fixing bolt of the sensor.
4. Remove the sensor.
5. Visually check the sensor for chipping.

Is the inspection result normal?

YES >> GO TO 2.

NO >> Replace EVT control position sensor. Refer to [EM-69](#), "[Exploded View](#)".

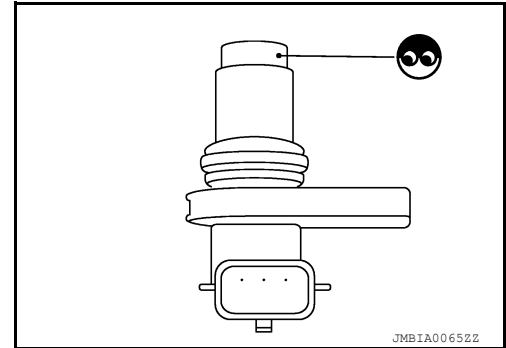

### 2. EVT CONTROL POSITION SENSOR-2

Check resistance EVT control position sensor terminals as shown below.

EVT control position sensor		Resistance
+	-	
Terminal		
1	2	Except 0 or $\infty$ $\Omega$ [at 25°C (77°F)]
	3	
2	3	

Is the inspection result normal?

YES >> INSPECTION END

NO >> Replace EVT control position sensor. Refer to [EM-69](#), "[Exploded View](#)".

# P1148 CLOSED LOOP CONTROL

< DTC/CIRCUIT DIAGNOSIS >

[QR25DE]

## P1148 CLOSED LOOP CONTROL

### DTC Description

INFOID:0000000011278107

### DTC DETECTION LOGIC

DTC No.	CONSULT screen terms (Trouble diagnosis content)	DTC detecting condition
P1148	CLOSED LOOP-B1 (CLOSED LOOP-B1)	The closed loop control function does not operate even when vehicle is being driven in the specified condition.

### POSSIBLE CAUSE

- Harness or connectors (A/F sensor 1 circuit is open or shorted.)
- A/F sensor 1
- A/F sensor 1 heater

### FAIL-SAFE

Not applicable

### Diagnosis Procedure

INFOID:0000000011278108

DTC P1148 is displayed with DTC for A/F sensor 1.

When the DTC is detected, perform the trouble diagnosis of DTC corresponding to A/F sensor 1.

Refer to [EC-96. "DTC Index"](#).

# P117A AIR FUEL RATIO

< DTC/CIRCUIT DIAGNOSIS >

[QR25DE]

## P117A AIR FUEL RATIO

### DTC Description

INFOID:000000011278109

### DTC DETECTION LOGIC

DTC No.	CONSULT screen terms (Trouble diagnosis content)	DTC detecting condition
P117A	AIR FUEL RATIO B1 (AIR FUEL RATIO B1)	ECM detects a lean/rich air fuel ratio state in any cylinder for a specified length of time.

### POSSIBLE CAUSE

- Fuel injector
- Exhaust gas leaks
- Incorrect fuel pressure
- Mass air flow sensor
- Intake air leaks
- Lack of fuel
- Incorrect PCV hose connection
- Improper spark plug
- Insufficient compression
- The fuel injector circuit is open or shorted
- Ignition coil
- The ignition signal circuit is open or shorted

### FAIL-SAFE

Not applicable

### DTC CONFIRMATION PROCEDURE

#### 1.CHECK DTC PRIORITY

If DTC P117A is displayed with other DTC, first perform the trouble diagnosis for other DTC.

#### Is applicable DTC detected?

- YES >> Perform diagnosis of applicable. Refer to [EC-96, "DTC Index"](#).  
NO >> GO TO 2.

#### 2.PRECONDITIONING-1

If DTC Confirmation Procedure has been previously conducted, always perform the following before conducting the next test.

1. Turn ignition switch OFF and wait at least 10 seconds.
2. Turn ignition switch ON.
3. Turn ignition switch OFF and wait at least 10 seconds.

#### **NOTE:**

**Before performing the following procedure, confirm that battery voltage is 11 V or more at idle.**

>> GO TO 3.

#### 3.PRECONDITIONING-2

1. Turn ignition switch ON.
2. Clear the mixture ratio self-learning value. Refer to [EC-146, "Work Procedure"](#).

#### Will CONSULT be used?

- YES >> GO TO 4.  
NO >> GO TO 7.

#### 4.PERFORM DTC CONFIRMATION PROCEDURE-1

1. Turn ignition switch ON.
2. Select "COOLAN TEMP/S" in "DATA MONITOR" mode of "ENGINE" using CONSULT.
3. Start engine.
4. Make sure that "COOLAN TEMP/S" indicates more than 80°C (176°F).



# P117A AIR FUEL RATIO

< DTC/CIRCUIT DIAGNOSIS >

[QR25DE]

>> GO TO 5.

## 5. PERFORM DTC CONFIRMATION PROCEDURE-2

### With CONSULT

1. Select "SYSTEM 1 DIAGNOSIS B B1" and "SYSTEM 1 DIAGNOSIS A B1" in "DATA MONITOR" mode of "ENGINE" using CONSULT.
2. Drive vehicle under the following conditions for at least 5 consecutive seconds.

**CAUTION:**

- Always drive vehicle at a safe speed.

ENG SPEED	1,300 – 2,000rpm
COOLAN TEMP/S	More than 80°C (176°F)
B/FUEL SCHDL	4 – 8 msec
Selector lever	D position
SYSTEM 1 DIAGNOSIS B B1	PRSENT

**NOTE:**

- Drive the vehicle at approximately 88 km/h (55MPH) allows easy diagnosis.
- Keep the accelerator pedal as possible during crusing.

3. Check "SYSTEM 1 DIAGNOSIS A B1" indication.

Is "CMPLT" displayed?

- YES >> GO TO 6.  
NO >> GO TO 3.

## 6. PERFORM DTC CONFIRMATION PROCEDURE-3

Check 1st trip DTC.

Is 1st trip DTC detected?

- YES >> Proceed to [EC-393, "Diagnosis Procedure"](#).  
NO >> INSPECTION END

## 7. PERFORM DTC CONFIRMATION PROCEDURE-4

### Without CONSULT

1. Start the engine and warm it up to normal operating temperature.
2. Drive vehicle under the following conditions for at least 5 consecutive seconds.

**CAUTION:**

- Always drive vehicle at a safe speed.

Engine speed	1,000 – 1,250 rpm
Calculated load value	26 – 46 %
Selector lever	D position

**NOTE:**

- Drive the vehicle at approximately 88 km/h (55MPH) allows easy diagnosis.
- Keep the accelerator pedal as possible during crusing.

3. Check 1st trip DTC.

Is 1st trip DTC detected?

- YES >> Proceed to [EC-393, "Diagnosis Procedure"](#).  
NO >> INSPECTION END

## Diagnosis Procedure

INFOID:000000011278110

### 1. CHECK DTC PRIORITY

If DTC P117A is displayed with other DTC, first perform the trouble diagnosis for other DTC.

Is applicable DTC detected?

# P117A AIR FUEL RATIO

[QR25DE]

## < DTC/CIRCUIT DIAGNOSIS >

- YES >> Perform diagnosis of applicable. Refer to [EC-96, "DTC Index"](#).  
NO >> GO TO 2.

### 2.CHECK FOR INTAKE AIR LEAK

1. Stop engine and check the following for connection.
  - Air duct
  - Vacuum hoses
  - PCV hose
  - Intake air passage between air duct to intake manifold
2. Start engine and let it idle.
3. Listen for an intake air leak after the mass air flow sensor.

#### Is the inspection result normal?

- YES >> GO TO 3.  
NO >> Repair or replace error-detected parts.

### 3.CHECK EXHAUST GAS LEAK

1. Stop engine and visually check exhaust tube, three way catalyst and muffler for dents connection.
2. Start engine and let it idle.
3. Listen for an exhaust gas leak before three way catalyst (manifold).

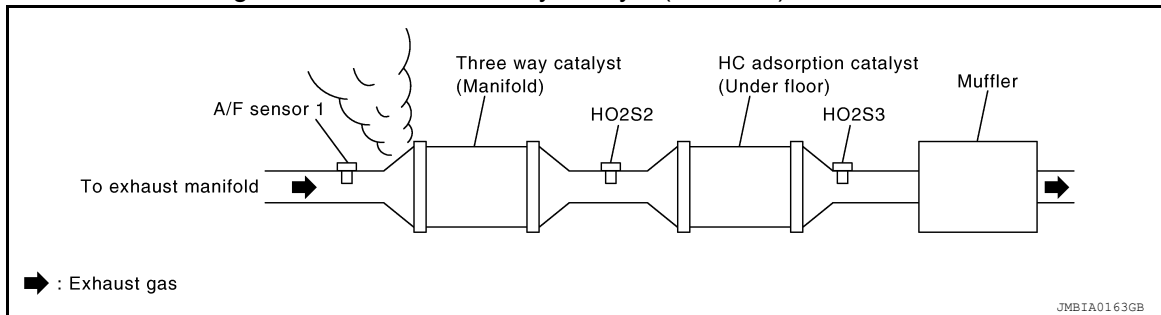

#### Is the inspection result normal?

- YES >> GO TO 4.  
NO >> Repair or replace error-detected parts.

### 4.CHECK FUEL PRESSURE

1. Release fuel pressure to zero. Refer to [EC-147, "Work Procedure"](#).
2. Check fuel pressure. Refer to [EC-147, "Work Procedure"](#).

#### Is the inspection result normal?

- YES >> GO TO 5.  
NO >> GO TO 10.

### 5.CHECK MASS AIR FLOW SENSOR

#### Ⓜ With CONSULT

Check "MASS AIR FLOW" in "DATA MONITOR" mode of "ENGINE" using CONSULT.  
For specification, refer to [EC-503, "Mass Air Flow Sensor"](#).

#### Ⓜ With GST

Check mass air flow sensor signal in Service \$01 using GST.  
For specification, refer to [EC-503, "Mass Air Flow Sensor"](#).

#### Is the inspection result normal?

- YES >> GO TO 6.  
NO >> Check connectors for rusted terminals or loose connections in the mass air flow sensor circuit or grounds. Refer to [EC-202, "Diagnosis Procedure"](#).

### 6.CHECK FUNCTION OF FUEL INJECTOR-1

#### Ⓜ With CONSULT

1. Start engine.
2. Perform "POWER BALANCE" in "ACTIVE TEST" mode of "ENGINE" using CONSULT.
3. Check that each circuit produces a momentary engine speed drop.

# P117A AIR FUEL RATIO

[QR25DE]

< DTC/CIRCUIT DIAGNOSIS >

## ⊗ Without CONSULT

1. Let engine idle.
2. Listen to each fuel injector operating sound.

**Clicking noise should be heard.**

Is the inspection result normal?

YES >> GO TO 7.

NO >> Perform trouble diagnosis for fuel injector, refer to [EC-467, "Component Function Check"](#).

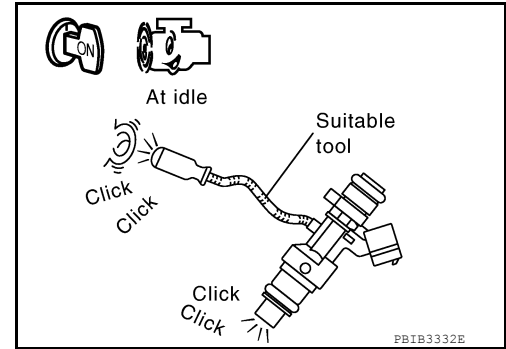

## 7. CHECK FUNCTION OF FUEL INJECTOR-2

### CAUTION:

**Perform the following procedure in a place with no combustible objects and good ventilation.**

1. Turn ignition switch OFF.
2. Confirm that the engine is cooled down and there are no fire hazards near the vehicle.
3. Disconnect all fuel injector harness connectors.
4. Remove fuel tube assembly. Refer to [EM-45, "Removal and Installation"](#).  
Keep fuel hose and all fuel injectors connected to fuel tube.
5. Disconnect all ignition coil harness connectors.
6. Prepare pans or saucers under each fuel injector.
7. Crank engine for approximately 3 seconds.

- Fuel should be sprayed evenly for each fuel injector.
- Fuel must not drip from the tip of fuel injector.

Is the inspection result normal?

YES >> GO TO 8.

NO >> Replace fuel injector. Refer to [EM-45, "Removal and Installation"](#).

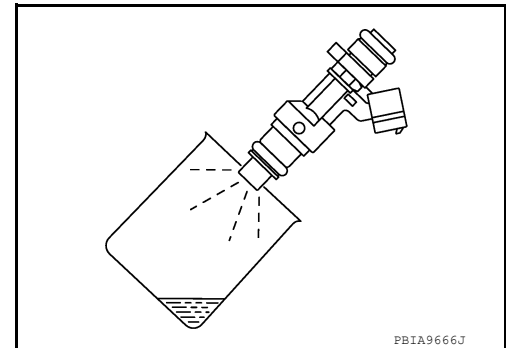

## 8. CHECK FUNCTION OF IGNITION COIL-1

### CAUTION:

**Perform the following steps in a well-ventilated area with no combustibles.**

1. Turn ignition switch OFF.
2. Remove fuel pump fuse from IPDM E/R to release fuel pressure.  
**NOTE:**  
**CONSULT must not be used to release fuel pressure. It develops again during the following steps, if released by using CONSULT.**
3. Start the engine.
4. After an engine stall, crank the engine two or three times to release all the fuel pressure.
5. Turn ignition switch OFF.
6. Disconnect all the harness connectors of ignition coil to prevent electric discharge from occurring in ignition coil.
7. Remove ignition coil assembly and spark plug of cylinder. Refer to [EM-41, "Removal and Installation"](#).
8. Crank engine for 5 seconds or more to remove combustion gas in the cylinder.
9. Connect spark plug and harness connector to ignition coil.

# P117A AIR FUEL RATIO

[QR25DE]

## < DTC/CIRCUIT DIAGNOSIS >

10. Allow a 13-17mm (0.52-0.66 in) spacing between spark plug and grounded metal portion as shown in the figure to fix the ignition coil with a rope or an equivalent.
11. Crank the engine for approximately 3 seconds to see if sparking occurs between spark plug and the grounded metal portion.

**Spark should be generated.**

### CAUTION:

- The discharge voltage becomes 20 kV or higher. Therefore, always stay away from the spark plug and ignition coil at least 50 cm (19.7 in) during the inspection.
- Leaving a space of more than 17mm (0.66 in) may damage the ignition coil.

### NOTE:

When the gap is less than 13 mm (0.52 in), a the spark might be generated even if the coil is malfunctioning.

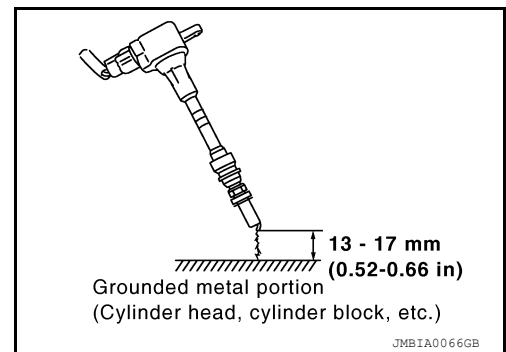

Is the inspection result normal?

- YES >> GO TO 9.  
NO >> GO TO 11.

## 9.CHECK COMPRESSION PRESSURE

Check compression pressure. Refer to [EM-24, "Compression pressure"](#).

Is the inspection result normal?

- YES >> GO TO 14.  
NO >> Check pistons, piston rings, valves, valve seats and cylinder head gaskets.

## 10.DETECT MALFUNCTIONING PART

Check fuel hoses and fuel tubes for clogging.

Is the inspection result normal?

- YES >> Replace fuel filter and fuel pump assembly. Refer to [FL-5, "Removal and Installation"](#).  
NO >> Repair or replace error-detected parts.

## 11.CHECK FUNCTION OF IGNITION COIL-2

1. Turn ignition switch OFF.
2. Disconnect spark plug and connect a non-malfunctioning spark plug.
3. Crank engine for approximately 3 seconds, and recheck whether spark is generated between the spark plug and the grounded metal portion.

**Spark should be generated.**

Is the inspection result normal?

- YES >> GO TO 12.  
NO >> Check ignition coil, power transistor and their circuits. Refer to [EC-473, "Component Function Check"](#).

## 12.CHECK SPARK PLUG

Check the initial spark plug for fouling, etc.

Is the inspection result normal?

- YES >> 1. Repair or clean spark plug. Refer to [EM-19, "Removal and Installation"](#).  
2. GO TO 13.  
NO >> Replace spark plug(s) with standard type one(s). For spark plug type, refer to [EM-120, "General Specification"](#).

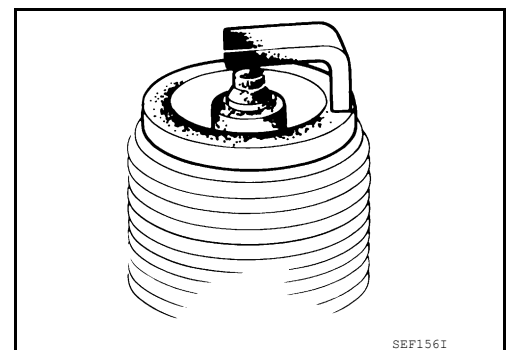

## 13.CHECK FUNCTION OF IGNITION COIL-3

# P117A AIR FUEL RATIO

[QR25DE]

< DTC/CIRCUIT DIAGNOSIS >

1. Reconnect the initial spark plugs.
2. Crank engine for approximately 3 seconds, and recheck whether spark is generated between the spark plug and the grounded portion.

**Spark should be generated.**

Is the inspection result normal?

YES >> GO TO 14.

NO >> Replace spark plug(s) with standard type one(s). For spark plug type, refer to [EM-120](#), "[General Specification](#)".

## 14.CHECK INTERMITTENT INCIDENT

Refer to [GI-44](#), "[Intermittent Incident](#)".

>> INSPECTION END

EC

C

D

E

F

G

H

I

J

K

L

M

N

O

P

# P1212 TCS COMMUNICATION LINE

< DTC/CIRCUIT DIAGNOSIS >

[QR25DE]

## P1212 TCS COMMUNICATION LINE

### Description

INFOID:0000000011278111

This CAN communication line is used to control the smooth engine operation during the TCS operation. Pulse signals are exchanged between ECM and “ABS actuator and electric unit (control unit)”.

**Be sure to erase the malfunction information such as DTC not only for “ABS actuator and electric unit (control unit)” but also for ECM after TCS related repair.**

### DTC Description

INFOID:0000000011278112

### DTC DETECTION LOGIC

**Freeze frame data is not stored in the ECM for this self-diagnosis.**

DTC No.	CONSULT screen terms (Trouble diagnosis content)	DTC detecting condition
P1212	TCS/CIRC (TCS/CIRC)	ECM can not receive the information from “ABS actuator and electric unit (control unit)” continuously.

### POSSIBLE CAUSE

- Harness or connectors (CAN communication line is open or shorted.)
- ABS actuator and electric unit (control unit)
- Dead (Weak) battery

### FAIL-SAFE

Not applicable

### DTC CONFIRMATION PROCEDURE

#### 1. CHECK DTC PRIORITY

If DTC P1212 is displayed with DTC UXXXX or P0607, first perform the trouble diagnosis for DTC UXXXX or P0607.

Is applicable DTC detected?

- YES >> Perform diagnosis of applicable. Refer to [EC-96. "DTC Index"](#).
- NO >> GO TO 2.

#### 2. PRECONDITIONING

If DTC Confirmation Procedure has been previously conducted, always perform the following procedure before conducting the next test.

1. Turn ignition switch OFF and wait at least 10 seconds.
2. Turn ignition switch ON.
3. Turn ignition switch OFF and wait at least 10 seconds.

#### TESTING CONDITION:

**Before performing the following procedure, confirm that battery voltage is more than 10.5V at idle.**

>> GO TO 3.

#### 3. PERFORM DTC CONFIRMATION PROCEDURE

1. Start engine and let it idle for at least 10 seconds.
2. Check 1st trip DTC.

Is 1st trip DTC detected?

- YES >> Proceed to [EC-398. "Diagnosis Procedure"](#).
- NO >> INSPECTION END

### Diagnosis Procedure

INFOID:0000000011278113

Perform the trouble diagnosis for TCS. Refer to [BRC-64. "Work Flow"](#).

#### NOTE:

If DTC P1212 is displayed with DTC UXXXX and/or P0607, perform the following trouble diagnosis.

- Trouble diagnosis for DTC UXXXX Refer to [EC-96. "DTC Index"](#).

# P1212 TCS COMMUNICATION LINE

< DTC/CIRCUIT DIAGNOSIS >

[QR25DE]

- Trouble diagnosis for DTC P0607 Refer to [EC-379, "DTC Description"](#).

A

EC

C

D

E

F

G

H

I

J

K

L

M

N

O

P

# P1217 ENGINE OVER TEMPERATURE

< DTC/CIRCUIT DIAGNOSIS >

[QR25DE]

## P1217 ENGINE OVER TEMPERATURE

### DTC Description

INFOID:0000000011278114

### DTC DETECTION LOGIC

If the cooling fan or another component in the cooling system malfunctions, engine coolant temperature will rise.

When the engine coolant temperature reaches an abnormally high temperature condition, a malfunction is indicated.

DTC No.	CONSULT screen terms (Trouble diagnosis content)	DTC detecting condition
P1217	ENG OVER TEMP (ENG OVER TEMP)	<ul style="list-style-type: none"><li>• Cooling fan does not operate properly (Overheat).</li><li>• Cooling fan system does not operate properly (Overheat).</li><li>• Engine coolant was not added to the system using the proper filling method.</li><li>• Engine coolant is not within the specified range.</li></ul>

### CAUTION:

When a malfunction is indicated, be sure to replace the coolant. Refer to [CO-8, "Draining"](#) and [CO-9, "Refilling"](#). Also, replace the engine oil. Refer to [LU-8, "Draining"](#) and [LU-8, "Refilling"](#).

1. Fill radiator with coolant up to specified level with a filling speed of 2 liters per minute. Be sure to use coolant with the proper mixture ratio. Refer to [MA-12, "Anti-Freeze Coolant Mixture Ratio"](#).
2. After refilling coolant, run engine to ensure that no water-flow noise is emitted.

### POSSIBLE CAUSE

- Harness or connectors (Cooling fan circuit is open or shorted.)
- IPDM E/R
- Cooling fan motor
- Radiator hose
- Radiator
- Radiator cap
- Reservoir tank
- Water pump
- Thermostat

### FAIL-SAFE

Not applicable

### DTC CONFIRMATION PROCEDURE

#### 1. CHECK DTC PRIORITY

If DTC P1217 is displayed with DTC UXXXX or P0607, first perform the trouble diagnosis for DTC UXXXX or P0607.

Is applicable DTC detected?

- YES >> Perform diagnosis of applicable. Refer to [EC-96, "DTC Index"](#).
- NO >> GO TO 2.

#### 2. PERFORM COMPONENT FUNCTION CHECK-1

### WARNING:

Never remove the radiator cap when the engine is hot. Serious burns could be caused by high pressure fluid escaping from the radiator.

Wrap a thick cloth around cap. Carefully remove the cap by turning it a quarter turn to allow built-up pressure to escape. Then turn the cap all the way off.



# P1217 ENGINE OVER TEMPERATURE

[QR25DE]

## < DTC/CIRCUIT DIAGNOSIS >

Check the coolant level in the reservoir tank and radiator.

**Allow engine to cool before checking coolant level.**

Is the coolant level in the reservoir tank and/or radiator below the proper range?

- YES >> Proceed to [EC-401, "Diagnosis Procedure"](#).  
NO >> GO TO 3.

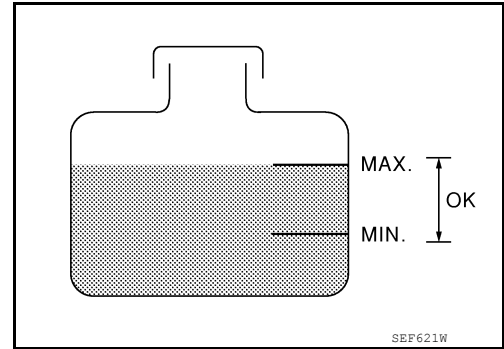

## 3.PERFORM COMPONENT FUNCTION CHECK-2

Confirm whether customer filled the coolant or not.

Did customer fill the coolant?

- YES >> Proceed to [EC-401, "Diagnosis Procedure"](#).  
NO >> GO TO 4.

## 4.PERFORM COMPONENT FUNCTION CHECK-3

ⓂWith CONSULT

1. Turn ignition switch ON.
2. Perform "FAN DUTY CONTROL" in "ACTIVE TEST" mode with CONSULT.
3. Make sure that cooling fan speed varies according to the percentage.

Is the inspection result normal?

- YES >> INSPECTION END  
NO >> Proceed to [EC-401, "Diagnosis Procedure"](#).

## Diagnosis Procedure

INFOID:0000000011278115

## 1.CHECK DTC PRIORITY

If DTC P1217 is displayed with DTC UXXXX or P0607, first perform the trouble diagnosis for DTC UXXXX or P0607.

Is applicable DTC detected?

- YES >> Perform diagnosis of applicable. Refer to [EC-96, "DTC Index"](#).  
NO >> GO TO 2.

## 2.CHECK COOLING FAN OPERATION

ⓂWith CONSULT

1. Turn ignition switch ON.
2. Perform "FAN DUTY CONTROL" in "ACTIVE TEST" mode with CONSULT.
3. Make sure that cooling fan speed varies according to the percentage.

Is the inspection result normal?

- YES >> GO TO 3.  
NO >> Proceed to [EC-461, "Diagnosis Procedure"](#).

## 3.CHECK COOLING SYSTEM FOR LEAK-1

Check cooling system for leak. Refer to [CO-8, "Inspection"](#).

Is leakage detected?

- YES >> GO TO 4.  
NO >> GO TO 5.

## 4.CHECK COOLING SYSTEM FOR LEAK-2

Check the following for leak.

- Hose (Refer to [CO-8, "Inspection"](#).)
- Radiator (Refer to [CO-12, "RADIATOR : Inspection"](#).)
- Water pump (Refer to [CO-19, "Removal and Installation"](#).)

## P1217 ENGINE OVER TEMPERATURE

< DTC/CIRCUIT DIAGNOSIS >

[QR25DE]

---

>> Repair or replace malfunctioning part.

### 5. CHECK RADIATOR CAP

---

Check radiator cap. Refer to [CO-12, "RADIATOR CAP : Inspection"](#).

Is the inspection result normal?

YES >> GO TO 6.

NO >> Replace radiator cap. Refer to [CO-13, "Exploded View"](#).

### 6. CHECK THERMOSTAT

---

Check thermostat. Refer to [CO-21, "Removal and Installation"](#).

Is the inspection result normal?

YES >> GO TO 7.

NO >> Replace thermostat. Refer to [CO-21, "Removal and Installation"](#).

### 7. CHECK ENGINE COOLANT TEMPERATURE SENSOR

---

Refer to [EC-215, "Component Inspection"](#).

Is the inspection result normal?

YES >> GO TO 8.

NO >> Replace engine coolant temperature sensor. Refer to [CO-23, "Exploded View"](#).

### 8. OVERHEATING CAUSE ANALYSIS

---

If the cause cannot be isolated, check the [CO-6, "Troubleshooting Chart"](#).

>> INSPECTION END

# P1225 TP SENSOR

< DTC/CIRCUIT DIAGNOSIS >

[QR25DE]

## P1225 TP SENSOR

### DTC Description

INFOID:000000011278116

### DTC DETECTION LOGIC

DTC No.	CONSULT screen terms (Trouble diagnosis content)	DTC detecting condition
P1225	CTP LEARNING-B1 (CTP LEARNING-B1)	Closed throttle position learning value is excessively low.

### POSSIBLE CAUSE

Electric throttle control actuator (TP sensor 1 and 2)

### FAIL-SAFE

Not applicable

### DTC CONFIRMATION PROCEDURE

#### 1. PRECONDITIONING

If DTC Confirmation Procedure has been previously conducted, always perform the following procedure before conducting the next test.

1. Turn ignition switch OFF and wait at least 10 seconds.
2. Turn ignition switch ON.
3. Turn ignition switch OFF and wait at least 10 seconds.

#### TESTING CONDITION:

Before performing the following procedure, confirm that battery voltage is more than 10 V at idle.

>> GO TO 2.

#### 2. PERFORM DTC CONFIRMATION PROCEDURE

1. Turn ignition switch ON.
2. Turn ignition switch OFF and wait at least 10 seconds.
3. Turn ignition switch ON.
4. Check 1st trip DTC.

#### Is 1st trip DTC detected?

- YES >> Proceed to [EC-403, "Diagnosis Procedure"](#).  
NO >> INSPECTION END

### Diagnosis Procedure

INFOID:000000011278117

#### 1. CHECK ELECTRIC THROTTLE CONTROL ACTUATOR VISUALLY

1. Turn ignition switch OFF.
2. Remove the intake air duct. Refer to [EM-26, "Exploded View"](#).
3. Check if foreign matter is caught between the throttle valve and the housing.

#### Is the inspection result normal?

- YES >> Replace electric throttle control actuator. Refer to [EM-29, "Removal and Installation"](#).  
NO >> Remove the foreign matter and clean the electric throttle control actuator inside, then perform throttle valve closed position learning. Refer to [EC-143, "Work Procedure"](#).

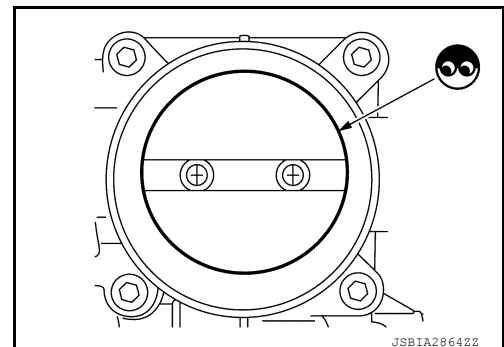

JSBIA2864ZZ

# P1226 TP SENSOR

< DTC/CIRCUIT DIAGNOSIS >

[QR25DE]

## P1226 TP SENSOR

### DTC Description

INFOID:0000000011278118

### DTC DETECTION LOGIC

DTC No.	CONSULT screen terms (Trouble diagnosis content)	DTC detecting condition
P1226	CTP LEARNING-B1 (CTP LEARNING-B1)	Closed throttle position learning is not performed successfully, repeatedly.

### POSSIBLE CAUSE

Electric throttle control actuator (TP sensor 1 and 2)

### FAIL-SAFE

Not applicable

### DTC CONFIRMATION PROCEDURE

#### 1. PRECONDITIONING

If DTC Confirmation Procedure has been previously conducted, always perform the following procedure before conducting the next test.

1. Turn ignition switch OFF and wait at least 10 seconds.
2. Turn ignition switch ON.
3. Turn ignition switch OFF and wait at least 10 seconds.

#### TESTING CONDITION:

**Before performing the following procedure, confirm that battery voltage is more than 10 V at idle.**

>> GO TO 2.

#### 2. PERFORM DTC CONFIRMATION PROCEDURE

1. Turn ignition switch ON.
2. Turn ignition switch OFF, wait at least 10 seconds.
3. Turn ignition switch ON.
4. Repeat steps 2 and 3 for 32 times.
5. Check 1st trip DTC.

#### Is 1st trip DTC detected?

- YES >> Proceed to [EC-404. "Diagnosis Procedure"](#).  
NO >> INSPECTION END

### Diagnosis Procedure

INFOID:0000000011278119

#### 1. CHECK ELECTRIC THROTTLE CONTROL ACTUATOR VISUALLY

1. Turn ignition switch OFF.
2. Remove the intake air duct. Refer to [EM-26. "Exploded View"](#).
3. Check if foreign matter is caught between the throttle valve and the housing.

#### Is the inspection result normal?

- YES >> Replace electric throttle control actuator. Refer to [EM-29. "Removal and Installation"](#).  
NO >> Remove the foreign matter and clean the electric throttle control actuator inside, then perform throttle valve closed position learning. Refer to [EC-143. "Work Procedure"](#).

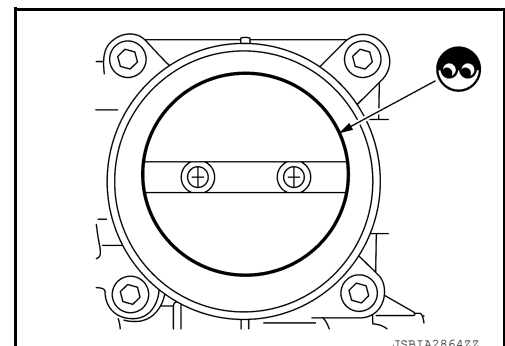

# P155D GENERATOR

< DTC/CIRCUIT DIAGNOSIS >

[QR25DE]

## P155D GENERATOR

### DTC Description

INFOID:0000000011278120

### DTC DETECTION LOGIC

DTC No.	CONSULT screen terms (Trouble diagnosis content)	DTC detecting condition
P155D	GENERATOR (Generator)	<ul style="list-style-type: none"><li>ECM receives mechanical malfunction signal sent from generator.</li><li>ECM receives electrical malfunction signal sent from generator.</li></ul>

### POSSIBLE CAUSE

Generator

### FAIL-SAFE

Not applicable

### DTC CONFIRMATION PROCEDURE

#### 1. PRECONDITIONING

If DTC Confirmation Procedure has been previously conducted, always perform the following procedure before conducting the next test.

1. Turn ignition switch OFF and wait at least 10 seconds.
2. Turn ignition switch ON.
3. Turn ignition switch OFF and wait at least 10 seconds.

>> GO TO 2.

#### 2. PERFORM DTC CONFIRMATION PROCEDURE

1. Start the engine and let it idle at least 10 seconds.
2. Check DTC.

#### Is DTC detected?

- YES >> Proceed to [EC-178. "Diagnosis Procedure"](#).  
NO >> INSPECTION END

### Diagnosis Procedure

INFOID:0000000011278121

#### 1. CHECK CHARGING SYSTEM

Perform trouble diagnosis for charging system. Refer to [EC-168. "Diagnosis Procedure"](#).

#### Is the inspection result normal?

- YES >> GO TO 2.  
NO >> Repair or replace error-detected parts.

#### 2. CHECK INTERMITTENT INCIDENT

Check intermittent incident. Refer to [GI-44. "Intermittent Incident"](#).

#### Is the inspection result normal?

- YES >> Replace generator. Refer to [CHG-20. "Removal and Installation"](#).  
NO >> Repair or replace error-detected parts.

# P1564 ASCD STEERING SWITCH

< DTC/CIRCUIT DIAGNOSIS >

[QR25DE]

## P1564 ASCD STEERING SWITCH

### DTC Description

INFOID:000000011278122

### DTC DETECTION LOGIC

DTC No.	CONSULT screen terms (Trouble diagnosis content)	DTC detecting condition
P1564	ASCD SW (ASCD switch)	<ul style="list-style-type: none"><li>An excessively high voltage signal from the ASCD steering switch is sent to ECM.</li><li>ECM detects that input signal from the ASCD steering switch is out of the specified range.</li><li>ECM detects that the ASCD steering switch is stuck ON.</li></ul>

### POSSIBLE CAUSE

- Harness or connectors (ASCD steering switch circuit is open or shorted.)
- ASCD steering switch
- ECM

### FAIL-SAFE

Not applicable

### DTC CONFIRMATION PROCEDURE

#### 1.CHECK DTC PRIORITY

If DTC P1564 is displayed with DTC P0603, P0604, P0605, P606, P0607, P060A, or P060B, first perform the trouble diagnosis for DTC P0603, P0604, P0605, P606, P0607, P060A, or P060B.

#### Is applicable DTC detected?

- YES >> Perform diagnosis of applicable. Refer to [EC-96, "DTC Index"](#).  
NO >> GO TO 2.

#### 2.PRECONDITIONING

If DTC Confirmation Procedure has been previously conducted, always perform the following procedure before conducting the next test.

- Turn ignition switch OFF and wait at least 10 seconds.
- Turn ignition switch ON.
- Turn ignition switch OFF and wait at least 10 seconds.

>> GO TO 3.

#### 3.PERFORM DTC CONFIRMATION PROCEDURE

- Turn ignition switch ON.
- Wait at least 10 seconds.
- Press MAIN switch for at least 10 seconds, then release it and wait at least 10 seconds.
- Press CANCEL switch for at least 10 seconds, then release it and wait at least 10 seconds.
- Press ACCEL/RES switch for at least 10 seconds, then release it and wait at least 10 seconds.
- Press COAST/SET switch for at least 10 seconds, then release it and wait at least 10 seconds.
- Check DTC.

#### Is DTC detected?

- YES >> Proceed to [EC-406, "Diagnosis Procedure"](#).  
NO >> INSPECTION END

### Diagnosis Procedure

INFOID:000000011278123

#### 1.CHECK DTC PRIORITY

If DTC P1564 is displayed with DTC P0603, P0604, P0605, P606, P0607, P060A, or P060B, first perform the trouble diagnosis for DTC P0603, P0604, P0605, P606, P0607, P060A, or P060B.

#### Is applicable DTC detected?

- YES >> Perform diagnosis of applicable. Refer to [EC-96, "DTC Index"](#).

# P1564 ASCD STEERING SWITCH

[QR25DE]

< DTC/CIRCUIT DIAGNOSIS >

NO >> GO TO 2.

## 2.CHECK ASCD STEERING SWITCH CIRCUIT

 With CONSULT

1. Turn ignition switch ON.
2. Select "CANCEL SW", "RESUME/ACC SW" and "SET SW" in "DATA MONITOR" mode of "ENGINE" using CONSULT.
3. Check each item indication as per the following conditions.

Monitor item	Condition		Indication
MAIN SW	MAIN switch	Pressed	ON
		Released	OFF
CANCEL SW	CANCEL switch	Pressed	ON
		Released	OFF
RESUME/ACC SW	ACCEL/RES switch	Pressed	ON
		Released	OFF
SET SW	COAST/SET switch	Pressed	ON
		Released	OFF

 Without CONSULT

1. Turn ignition switch ON.
2. Check the voltage between ECM harness connector terminals.

ECM			Condition	Voltage (Approx.)
Connector	+	-		
		Terminal		
E16	110	111	MAIN switch: Pressed	0 V
			CANCEL switch: Pressed	1 V
			COAST/SET switch: Pressed	2 V
			ACCEL/RES switch: Pressed	3 V
			All ASCD steering switches: Released	4 V

Is the inspection result normal?

YES >> GO TO 6.

NO >> GO TO 3.

## 3.CHECK ASCD STEERING SWITCH GROUND CIRCUIT

1. Turn ignition switch OFF.
2. Disconnect ECM harness connector.
3. Disconnect combination switch (spiral cable) harness connector.
4. Check the continuity between combination switch (spiral cable) and ECM harness connector.

+		-		Continuity
Combination switch (Spiral cable)		ECM		
Connector	Terminal	Connector	Terminal	
M30	7	E16	111	Existed

5. Also check harness for short to ground and to power.

Is the inspection result normal?

YES >> GO TO 4.

NO >> Repair or replace error-detected parts.

## 4.CHECK ASCD STEERING SWITCH INPUT SIGNAL CIRCUIT

# P1564 ASCD STEERING SWITCH

[QR25DE]

## < DTC/CIRCUIT DIAGNOSIS >

1. Check the continuity between ECM harness connector and combination switch.

+		-		Continuity
Combination switch (Spiral cable)		ECM		
Connector	Terminal	Connector	Terminal	
M30	6	E16	110	Existed

2. Also check harness for short to ground and to power.

Is the inspection result normal?

YES >> GO TO 5.

NO >> Repair or replace error-detected parts.

## 5.CHECK ASCD STEERING SWITCH

Refer to [EC-408, "Component Inspection"](#).

Is the inspection result normal?

YES >> GO TO 6.

NO >> Replace ASCD steering switch. Refer to [ST-11, "Removal and Installation"](#).

## 6.CHECK INTERMITTENT INCIDENT

Refer to [GI-44, "Intermittent Incident"](#).

>> INSPECTION END

## Component Inspection

INFOID:0000000011278124

## 1.CHECK ASCD STEERING SWITCH

1. Disconnect combination switch (spiral cable) harness connector.
2. Check the resistance between combination switch harness connector terminals as per the following conditions.

Combination switch (Spiral cable)			Condition	Resistance (Approx.)
Connector	+	-		
	Terminals			
M90	27	26	MAIN switch: Pressed	0 Ω
			CANCEL switch: Pressed	250 Ω
			COAST/SET switch: Pressed	660 Ω
			ACCEL/RES switch: Pressed	1,480 Ω
			All ASCD steering switches: Released	4,000 Ω

Is the inspection result normal?

YES >> INSPECTION END

NO >> Replace ASCD steering switch. Refer to [ST-11, "Exploded View"](#).



# P1568 SIGNAL INVALID

< DTC/CIRCUIT DIAGNOSIS >

[QR25DE]

## P1568 SIGNAL INVALID

### DTC Description

INFOID:0000000011278125

### DTC DETECTION LOGIC

DTC No.	CONSULT screen terms (Trouble diagnosis content)	DTC detecting condition
P1568	ICC COMMAND VALUE (Intelligent cruise control command value)	ECM detects that a throttle valve opening angle request signal sent from chassis control module is difference from the specified value calculated by ECM.

### POSSIBLE CAUSE

- Chassis control module
- ECM

### FAIL-SAFE

Active trace control does not function.

### DTC CONFIRMATION PROCEDURE

#### 1.CHECK DTC PRIORITY

If DTC P1568 is displayed with DTC UXXXX, first perform the confirmation procedure for DTC UXXXX.

#### Is applicable DTC detected?

- YES >> Perform diagnosis for detected DTC. Refer to [EC-96, "DTC Index"](#).  
NO >> GO TO 2.

#### 2.PRECONDITIONING

If DTC Confirmation Procedure has been previously conducted, always perform the following procedure before conducting the next test.

1. Turn ignition switch OFF and wait at least 10 seconds.
2. Turn ignition switch ON.
3. Turn ignition switch OFF and wait at least 10 seconds.

>> GO TO 3.

#### 3.PERFORM DTC CONFIRMATION PROCEDURE

1. Turn ignition switch ON and wait at least 5 seconds.
2. Check DTC.

#### Is DTC detected?

- YES >> Proceed to [EC-409, "Diagnosis Procedure"](#).  
NO >> INSPECTION END

### Diagnosis Procedure

INFOID:0000000011278126

#### 1.CHECK DTC PRIORITY

If DTC P1568 is displayed with DTC UXXXX, first perform the confirmation procedure for DTC UXXXX.

#### Is applicable DTC detected?

- YES >> Perform diagnosis for detected DTC. Refer to [EC-96, "DTC Index"](#).  
NO >> GO TO 2.

#### 2.CHECK SELF-DIAGNOSTIC RESULT OF CHASSIS CONTROL MODULE

Check that the chassis control module does not detect any DTC.

#### Is any DTC detected?

- YES >> GO TO 3.  
NO >> Replace chassis control module. Refer to [DAS-286, "Removal and Installation"](#).

#### 3.REPLACE CHASSIS CONTROL MODULE

## P1568 SIGNAL INVALID

[QR25DE]

< DTC/CIRCUIT DIAGNOSIS >

---

1. Replace chassis control module. Refer to [DAS-286. "Removal and Installation"](#).
2. Perform DTC Confirmation Procedure again.

Is DTC P1568 detected again?

- YES >> Replace ECM. Refer to [EC-502. "Removal and Installation"](#).
- NO >> INSPECTION END

# P1572 BRAKE PEDAL POSITION SWITCH

< DTC/CIRCUIT DIAGNOSIS >

[QR25DE]

## P1572 BRAKE PEDAL POSITION SWITCH

### DTC Description

INFOID:000000011278127

### DTC DETECTION LOGIC

#### NOTE:

**This self-diagnosis has the one trip detection logic. When malfunction A is detected, DTC is not stored in ECM memory. And in that case, 1st trip DTC and 1st trip freeze frame data are displayed. 1st trip DTC is erased when ignition switch OFF. And even when malfunction A is detected in two consecutive trips, DTC is not stored in ECM memory.**

DTC No.	CONSULT screen terms (Trouble diagnosis content)	DTC detecting condition	
P1572	ASCD BRAKE SW (ASCD BRAKE SW)	A	When the vehicle speed is above 30 km/h (19 MPH), ON signals from the stop lamp switch and the brake pedal position switch are sent to the ECM at the same time.
		B	Brake pedal position switch signal is not sent to ECM for extremely long time while the vehicle is driving.

### POSSIBLE CAUSE

- Harness or connectors
- Stop lamp switch circuit is shorted.
- Brake pedal position switch circuit is shorted.
- Stop lamp switch
- Brake pedal position switch
- Incorrect stop lamp switch installation
- Incorrect brake pedal position switch installation
- ECM

### FAIL-SAFE

Not applicable

### DTC CONFIRMATION PROCEDURE

#### 1.CHECK DTC PRIORITY

If DTC P1572 is displayed with DTC P0603, P0604, P0605, P0606, P0607, P060A, or P060B, first perform the trouble diagnosis for DTC P0603, P0604, P0605, P0606, P0607, P060A, or P060B.

#### Is applicable DTC detected?

- YES >> Perform diagnosis of applicable. Refer to [EC-96, "DTC Index"](#).  
NO >> GO TO 2.

#### 2.PRECONDITIONING

If DTC Confirmation Procedure has been previously conducted, always perform the following procedure before conducting the next test.

1. Turn ignition switch OFF and wait at least 10 seconds.
2. Turn ignition switch ON.
3. Turn ignition switch OFF and wait at least 10 seconds.

#### NOTE:

Procedure for malfunction B is not described here. It takes extremely long time to complete procedure for malfunction B. By performing procedure for malfunction A, the incident that causes malfunction B can be detected.

>> GO TO 3.

#### 3.PERFORM DTC CONFIRMATION PROCEDURE FOR MALFUNCTION A

1. Start engine.
2. Press MAIN switch and make sure that CRUISE indicator is displayed in combination meter.
3. Drive the vehicle for at least 5 consecutive seconds as per the following conditions.

**CAUTION:**

# P1572 BRAKE PEDAL POSITION SWITCH

< DTC/CIRCUIT DIAGNOSIS >

[QR25DE]

**Always drive vehicle at a safe speed.**

**NOTE:**

**This procedure may be conducted with the drive wheels lifted in the shop or by driving the vehicle. If a road test is expected to be easier, it is unnecessary to lift the vehicle.**

Vehicle speed	More than 30 km/h (19 mph)
Selector lever	Suitable position

4. Check DTC.

Is DTC detected?

YES >> Proceed to [EC-418, "Diagnosis Procedure"](#).

NO >> GO TO 4.

## 4.PERFORM DTC CONFIRMATION PROCEDURE FOR MALFUNCTION B

1. Drive the vehicle for at least 5 consecutive seconds as per the following conditions.

**CAUTION:**

**Always drive vehicle at a safe speed.**

**NOTE:**

**This procedure may be conducted with the drive wheels lifted in the shop or by driving the vehicle. If a road test is expected to be easier, it is unnecessary to lift the vehicle.**

Vehicle speed	More than 30 km/h (19 mph)
Selector lever	Suitable position
Driving location	Depress the brake pedal for more than five seconds so as not to come off from the above-mentioned vehicle speed.

2. Check DTC.

Is DTC detected?

YES >> Proceed to [EC-418, "Diagnosis Procedure"](#).

NO >> INSPECTION END

## Diagnosis Procedure

INFOID:000000011278128

### 1.CHECK DTC PRIORITY

If DTC P1572 is displayed with DTC P0603, P0604, P0605, P0606, P0607, P060A, or P060B, first perform the trouble diagnosis for DTC P0603, P0604, P0605, P0606, P0607, P060A, or P060B.

Is applicable DTC detected?

YES >> Perform diagnosis of applicable. Refer to [EC-96, "DTC Index"](#).

NO >> GO TO 2.

### 2.CHECK OVERALL FUNCTION-1

Ⓟ With CONSULT

1. Turn ignition switch ON.
2. Select "BRAKE SW1" in "DATA MONITOR" mode of "ENGINE" using CONSULT.
3. Check "BRAKE SW1" indication as per the following conditions.

Monitor item	Condition		Indication
BRAKE SW1	Brake pedal	Slightly depressed	OFF
		Fully released	ON

ⓧ Without CONSULT

1. Turn ignition switch ON.
2. Check the voltage between ECM harness connector terminals as per the following.

# P1572 BRAKE PEDAL POSITION SWITCH

[QR25DE]

< DTC/CIRCUIT DIAGNOSIS >

ECM			Condition	Voltage (Approx.)	
Connector	+	-			
	Terminal				
E16	116	128	Brake pedal	Slightly depressed	0 V
			Fully released	Battery voltage	

Is the inspection result normal?

- YES >> GO TO 3.
- NO >> GO TO 4.

## 3.CHECK OVERALL FUNCTION-2

With CONSULT

Select "BRAKE SW2" and check indication as per the following conditions.

Monitor item	Condition	Indication	
BRAKE SW2	Brake pedal	Slightly depressed	ON
	Fully released	OFF	

Without CONSULT

Check the voltage between ECM harness connector terminals as per the following conditions.

ECM			Condition	Voltage (Approx.)	
Connector	+	-			
	Terminal				
E16	115	128	Brake pedal	Slightly depressed	Battery voltage
			Fully released	0 V	

Is the inspection result normal?

- YES >> Check intermittent incident. Refer to [GI-44. "Intermittent Incident"](#).
- NO >> GO TO 7.

## 4.CHECK BRAKE PEDAL POSITION SWITCH POWER SUPPLY

1. Turn ignition switch OFF.
2. Disconnect brake pedal position switch harness connector.
3. Turn ignition switch ON.
4. Check the voltage between brake pedal position switch harness connector and ground.

+		-	Voltage
Brake pedal position switch	Terminal		
Connector	Terminal		
E6	1	Ground	Battery voltage

Is the inspection result normal?

- YES >> GO TO 5.
- NO >> Perform the trouble diagnosis for power supply circuit.

## 5.CHECK BRAKE PEDAL POSITION SWITCH INPUT SIGNAL CIRCUIT

1. Turn ignition switch OFF.
2. Disconnect ECM harness connector.
3. Check the continuity between brake pedal position switch harness connector and ECM harness connector.

# P1572 BRAKE PEDAL POSITION SWITCH

[QR25DE]

< DTC/CIRCUIT DIAGNOSIS >

+		-		Continuity
Brake pedal position switch		ECM		
Connector	Terminal	Connector	Terminal	
E6	2	E16	116	Existed

4. Also check harness for short to ground and to power.

Is the inspection result normal?

YES >> GO TO 6.

NO >> Repair or replace error-detected parts.

## 6. CHECK BRAKE PEDAL POSITION SWITCH

Check the brake pedal position switch. Refer to [EC-414, "Component Inspection \(Brake Pedal Position Switch\)"](#)

Is the inspection result normal?

YES >> Check intermittent incident. Refer to [GI-44, "Intermittent Incident"](#).

NO >> Replace brake pedal position switch. Refer to [BR-20, "Exploded View"](#).

## 7. CHECK STOP LAMP SWITCH POWER SUPPLY CIRCUIT

1. Turn ignition switch OFF.
2. Disconnect stop lamp switch harness connector.
3. Check the voltage between stop lamp switch harness connector and ground.

+		-	Voltage
Stop lamp switch			
Connector	Terminal		
E38	1	Ground	Battery voltage

Is the inspection result normal?

YES >> GO TO 8.

NO >> Perform the trouble diagnosis for power supply circuit.

## 8. CHECK STOP LAMP SWITCH GROUND CIRCUIT

1. Check the continuity between stop lamp switch harness connector and ECM harness connector.

+		-		Continuity
Stop lamp switch		ECM		
Connector	Terminal	Connector	Terminal	
E38	2	E16	115	Existed

2. Also check harness for short to ground and to power.

Is the inspection result normal?

YES >> GO TO 9.

NO >> Repair or replace error-detected parts.

## 9. CHECK STOP LAMP SWITCH

Check the stop lamp switch. Refer to [EC-415, "Component Inspection \(Stop Lamp Switch\)"](#).

Is the inspection result normal?

YES >> Check intermittent incident. Refer to [GI-44, "Intermittent Incident"](#).

NO >> Replace stop lamp switch. Refer to [BR-20, "Exploded View"](#).

## Component Inspection (Brake Pedal Position Switch)

INFOID:0000000011278129

### 1. CHECK BRAKE PEDAL POSITION SWITCH-1

1. Turn ignition switch OFF.
2. Disconnect brake pedal position harness connector.

# P1572 BRAKE PEDAL POSITION SWITCH

[QR25DE]

## < DTC/CIRCUIT DIAGNOSIS >

- Check the continuity between brake pedal position switch terminals as per the following conditions.

Brake pedal position switch		Condition	Continuity
+	-		
Terminals			
1	2	Brake pedal	Fully released Existed
			Slightly de-pressed Not existed

Is the inspection result normal?

- YES >> INSPECTION END  
NO >> GO TO 2.

## 2.CHECK BRAKE PEDAL POSITION SWITCH-2

- Adjust brake pedal position switch installation. Refer to [BR-15. "Adjustment"](#).
- Check the continuity between brake pedal position switch terminals as per the following conditions.

Brake pedal position switch		Condition	Continuity
+	-		
Terminals			
1	2	Brake pedal	Fully released Existed
			Slightly de-pressed Not existed

Is the inspection result normal?

- YES >> INSPECTION END  
NO >> Replace brake pedal position switch. Refer to [BR-20. "Exploded View"](#).

## Component Inspection (Stop Lamp Switch)

INFOID:0000000011278130

## 1.CHECK STOP LAMP SWITCH-1

- Turn ignition switch OFF.
- Disconnect stop lamp switch harness connector.
- Check the continuity between stop lamp switch terminals as per the following conditions.

Stop lamp switch		Condition	Continuity
+	-		
Terminals			
1	2	Brake pedal	Fully released Not existed
			Slightly de-pressed Existed

Is the inspection result normal?

- YES >> INSPECTION END  
NO >> GO TO 2.

## 2.CHECK STOP LAMP SWITCH-2

- Adjust stop lamp switch installation. Refer to [BR-7. "Inspection"](#).
- Check the continuity between stop lamp switch terminals as per the following conditions.

# P1572 BRAKE PEDAL POSITION SWITCH

< DTC/CIRCUIT DIAGNOSIS >

[QR25DE]

Stop lamp switch		Condition	Continuity	
+	-			
Terminals				
1	2	Brake pedal	Fully released	Not existed
			Slightly de-pressed	Existed

Is the inspection result normal?

YES >> INSPECTION END

NO >> Replace stop lamp switch. Refer to [BR-20, "Exploded View"](#).



# P1574 ASCD VEHICLE SPEED SENSOR

< DTC/CIRCUIT DIAGNOSIS >

[QR25DE]

## P1574 ASCD VEHICLE SPEED SENSOR

### Description

INFOID:0000000011278131

The ECM receives two vehicle speed sensor signals via CAN communication line. One is sent from combination meter, and the other is from TCM (Transmission control module). The ECM uses these signals for ASCD control. Refer to [EC-49. "AUTOMATIC SPEED CONTROL DEVICE \(ASCD\) : System Description"](#) for ASCD functions.

### DTC Description

INFOID:0000000011278132

### DTC DETECTION LOGIC

DTC No.	CONSULT screen terms (Trouble diagnosis content)	DTC detecting condition
P1574	ASCD VHL SPD SEN (ASCD VHL SPD SEN)	ECM detects a difference between two vehicle speed signals is out of the specified range.

### POSSIBLE CAUSE

- Harness or connectors (CAN communication line is open or shorted.)
- ABS actuator and electric unit (control unit)
- TCM
- ECM

### FAIL-SAFE

Not applicable

### DTC CONFIRMATION PROCEDURE

#### 1. CHECK DTC PRIORITY

If DTC P1574 is displayed with DTC U1001, P0500, P0603, P0604, P0605, P0606, P0607, P060A or P060B, first perform the trouble diagnosis for DTC U1001, P0500, P0603, P0604, P0605, P0606, P0607, P060A or P060B.

Is applicable DTC detected?

- YES >> Perform diagnosis of applicable. Refer to [EC-96. "DTC Index"](#).  
NO >> GO TO 2.

#### 2. PRECONDITIONING

If DTC Confirmation Procedure has been previously conducted, always perform the following procedure before conducting the next test.

1. Turn ignition switch OFF and wait at least 10 seconds.
2. Turn ignition switch ON.
3. Turn ignition switch OFF and wait at least 10 seconds.

>> GO TO 3.

#### 3. PERFORM DTC CONFIRMATION PROCEDURE

1. Start engine.
2. Drive the vehicle at more than 40 km/h (25 MPH).

**CAUTION:**

**Always drive vehicle at a safe speed.**

**NOTE:**

**This procedure may be conducted with the drive wheels lifted in the shop or by driving the vehicle. If a road test is expected to be easier, it is unnecessary to lift the vehicle.**

3. Check DTC.

Is DTC detected?

- YES >> Proceed to [EC-418. "Diagnosis Procedure"](#).  
NO >> INSPECTION END

# P1574 ASCD VEHICLE SPEED SENSOR

[QR25DE]

< DTC/CIRCUIT DIAGNOSIS >

## Diagnosis Procedure

INFOID:000000011278133

### 1.CHECK DTC PRIORITY

If DTC P1574 is displayed with DTC U1001, P0500, P0603, P0604, P0605, P0606, P0607, P060A or P060B, first perform the trouble diagnosis for DTC U1001, P0500, P0603, P0604, P0605, P0606, P0607, P060A or P060B.

Is applicable DTC detected?

- YES >> Perform diagnosis of applicable. Refer to [EC-96. "DTC Index"](#).
- NO >> GO TO 2.

### 2.CHECK DTC WITH TCM

Check DTC with TCM. Refer to [TM-47. "CONSULT Function"](#).

Is DTC detected?

- NO >> GO TO 3.
- YES >> Perform trouble shooting relevant to DTC indicated.

### 3.CHECK DTC WITH "ABS ACTUATOR AND ELECTRIC UNIT (CONTROL UNIT)"

Check DTC with ABS actuator and electric unit (control unit). Refer to [BRC-42. "CONSULT Function"](#).

Is DTC detected?

- NO >> INSPECTION END
- YES >> Perform trouble shooting relevant to DTC indicated.

# P1715 INPUT SPEED SENSOR

< DTC/CIRCUIT DIAGNOSIS >

[QR25DE]

## P1715 INPUT SPEED SENSOR

### Description

INFOID:0000000011278134

ECM receives input speed sensor signal from TCM through CAN communication line. ECM uses this signal for engine control.

### DTC Description

INFOID:0000000011278135

### DTC DETECTION LOGIC

DTC No.	CONSULT screen terms (Trouble diagnosis content)	DTC detecting condition
P1715	IN PULY SPEED (IN PULY SPEED)	Input speed sensor signal is different from the theoretical value calculated by ECM from output speed sensor signal and engine rpm signal.

### POSSIBLE CAUSE

- Harness or connectors (The CAN communication line is open or shorted.)
- Harness or connectors (Input speed sensor circuit is open or shorted.)
- TCM

### FAIL-SAFE

Not applicable

### DTC CONFIRMATION PROCEDURE

#### 1.CHECK DTC PRIORITY

If DTC P1715 is displayed with DTC UXXXX, P0335, P0340, P0603, P0604, P0605, P0606, P0607, P060A, or P060B, first perform the trouble diagnosis for DTC UXXXX, P0335, P0340, P0603, P0604, P0605, P0606, P0607, P060A, or P060B.

Is applicable DTC detected?

- YES >> Perform diagnosis of applicable. Refer to [EC-96. "DTC Index"](#).  
NO >> GO TO 2.

#### 2.PRECONDITIONING

If DTC Confirmation Procedure has been previously conducted, always perform the following before conducting the next test.

1. Turn ignition switch OFF and wait at least 10 seconds.
2. Turn ignition switch ON.
3. Turn ignition switch OFF and wait at least 10 seconds.

>> GO TO 3.

#### 3.PERFORM DTC CONFIRMATION PROCEDURE

1. Start engine and drive the vehicle at more than 50 km/h (31 MPH) for at least 5 seconds.

**CAUTION:**

**Always drive vehicle at a safe speed.**

2. Check 1st trip DTC.

Is 1st trip DTC detected?

- YES >> Proceed to [EC-419. "Diagnosis Procedure"](#).  
NO >> INSPECTION END

### Diagnosis Procedure

INFOID:0000000011278136

#### 1.CHECK DTC PRIORITY

If DTC P1715 is displayed with DTC UXXXX, P0335, P0340, P0603, P0604, P0605, P0606, P0607, P060A, or P060B, first perform the trouble diagnosis for DTC UXXXX, P0335, P0340, P0603, P0604, P0605, P0606, P0607, P060A, or P060B.

Is applicable DTC detected?

## P1715 INPUT SPEED SENSOR

[QR25DE]

< DTC/CIRCUIT DIAGNOSIS >

---

- YES >> Perform diagnosis of applicable. Refer to [EC-96. "DTC Index"](#).
- NO >> GO TO 2.

### 2.CHECK DTC WITH TCM

---

Check DTC with TCM. Refer to [TM-47. "CONSULT Function"](#).

Is the inspection result normal?

- YES >> GO TO 3.
- NO >> Perform trouble shooting relevant to DTC indicated.

### 3.REPLACE TCM

---

Replace TCM. Refer to [TM-202. "Removal and Installation"](#).

>> INSPECTION END

# P1805 BRAKE SWITCH

< DTC/CIRCUIT DIAGNOSIS >

[QR25DE]

## P1805 BRAKE SWITCH

### DTC Description

INFOID:000000011278137

### DTC DETECTION LOGIC

DTC No.	CONSULT screen terms (Trouble diagnosis content)	DTC detecting condition
P1805	BRAKE SW/CIRCUIT (BRAKE SW/CIRCUIT)	A stop lamp switch signal is not sent to ECM for extremely long time while the vehicle is driving.

### POSSIBLE CAUSE

- Harness or connectors (Stop lamp switch circuit is open or shorted.)
- Stop lamp switch

### FAIL-SAFE

ECM controls the electric throttle control actuator by regulating the throttle opening to a small range. Therefore, acceleration will be poor.

Vehicle condition	Driving condition
When engine is idling	Normal
When accelerating	Poor acceleration

### DTC CONFIRMATION PROCEDURE

#### 1. PERFORM DTC CONFIRMATION PROCEDURE

1. Turn ignition switch ON.
2. Fully depress the brake pedal for at least 5 seconds.
3. Erase the DTC.
4. Check 1st trip DTC.

#### Is 1st trip DTC detected?

- YES >> Proceed to [EC-421, "Diagnosis Procedure"](#).  
 NO >> INSPECTION END

### Diagnosis Procedure

INFOID:000000011278138

#### 1. CHECK STOP LAMP SWITCH POWER SUPPLY CIRCUIT

1. Turn ignition switch OFF.
2. Disconnect stop lamp switch harness connector.
3. Check the voltage between stop lamp switch harness connector and ground.

+		-	Voltage
Connector	Terminal		
E38	1	Ground	Battery voltage

#### Is the inspection result normal?

- YES >> GO TO 2.  
 NO >> Perform the trouble diagnosis for power supply circuit.

#### 2. CHECK STOP LAMP SWITCH GROUND CIRCUIT

1. Disconnect ECM harness connector.
2. Check the continuity between stop lamp switch harness connector and ECM harness connector.

# P1805 BRAKE SWITCH

< DTC/CIRCUIT DIAGNOSIS >

[QR25DE]

+		-		Continuity
Stop lamp switch		ECM		
Connector	Terminal	Connector	Terminal	
E38	2	E16	115	Existed

3. Also check harness for short to ground and to power.

Is the inspection result normal?

YES >> GO TO 3.

NO >> Repair or replace error-detected parts.

## 3.CHECK STOP LAMP SWITCH

Check the stop lamp switch. Refer to [EC-415, "Component Inspection \(Stop Lamp Switch\)"](#).

Is the inspection result normal?

YES >> Check intermittent incident. Refer to [GI-44, "Intermittent Incident"](#).

NO >> Replace stop lamp switch. Refer to [BR-20, "Exploded View"](#).

## Component Inspection (Stop Lamp Switch)

INFOID:000000011278139

### 1.CHECK STOP LAMP SWITCH-1

1. Turn ignition switch OFF.
2. Disconnect stop lamp switch harness connector.
3. Check the continuity between stop lamp switch terminals as per the following conditions.

Stop lamp switch		Condition	Continuity
+	-		
Terminals			
1	2	Brake pedal	Fully released Not existed
			Slightly de-pressed Existed

Is the inspection result normal?

YES >> INSPECTION END

NO >> GO TO 2.

### 2.CHECK STOP LAMP SWITCH-2

1. Adjust stop lamp switch installation. Refer to [BR-15, "Adjustment"](#).
2. Check the continuity between stop lamp switch terminals as per the following conditions.

Stop lamp switch		Condition	Continuity
+	-		
Terminals			
1	2	Brake pedal	Fully released Not existed
			Slightly de-pressed Existed

Is the inspection result normal?

YES >> INSPECTION END

NO >> Replace stop lamp switch. Refer to [BR-20, "Exploded View"](#).

# P2004 INTAKE MANIFOLD RUNNER CONTROL VALVE

< DTC/CIRCUIT DIAGNOSIS >

[QR25DE]

## P2004 INTAKE MANIFOLD RUNNER CONTROL VALVE

### DTC Description

INFOID:000000011278140

### DTC DETECTION LOGIC

DTC No.	CONSULT screen terms (Trouble diagnosis content)	DTC detecting condition
P2004	TUMBLE CONT/V (Intake manifold runner control stuck open bank 1)	The target angle of intake manifold runner control valve controlled by ECM and the input signal from intake manifold runner control valve position sensor is not in the normal range.

### POSSIBLE CAUSE

- Harness or connectors (Intake manifold runner control valve motor circuit is open or shorted.)
- Intake manifold runner control valve motor
- Intake manifold runner control valve is stuck

### FAIL-SAFE

- Traveling control mode (Engine output control)
- Device fix mode

### DTC CONFIRMATION PROCEDURE

#### 1. PRECONDITIONING

If DTC Confirmation Procedure has been previously conducted, always turn ignition switch OFF and wait at least 10 seconds before conducting the next test.

#### TESTING CONDITION:

- Before performing the following procedure, confirm that battery voltage is more than 11 V at idle.
- Always perform the test at a temperature above  $-7^{\circ}\text{C}$  ( $19^{\circ}\text{F}$ )

>> GO TO 2.

#### 2. PERFORM DTC CONFIRMATION PROCEDURE

##### With CONSULT

1. Turn ignition switch ON.
2. Select "DATA MONITOR" mode with CONSULT.
3. Make sure that "COOLAN TEMP/S" indicates between  $-7^{\circ}\text{C}$  ( $19^{\circ}\text{F}$ ) to  $60^{\circ}\text{C}$  ( $140^{\circ}\text{F}$ ).  
If not, cool engine down or warm engine up until "COOLAN TEMP/S" indicates between  $-7^{\circ}\text{C}$  ( $19^{\circ}\text{F}$ ) to  $60^{\circ}\text{C}$  ( $140^{\circ}\text{F}$ ). Then go to the following steps.
4. Fully release accelerator pedal and wait at least 10 seconds.
5. Depress accelerator pedal and wait at least 10 seconds.
6. Check 1st trip DTC.

##### With GST

Following the procedure "With CONSULT" above.

#### Is 1st trip DTC detected?

- YES >> Proceed to [EC-423, "Diagnosis Procedure"](#).  
NO >> INSPECTION END

### Diagnosis Procedure

INFOID:000000011278141

#### 1. CHECK INTAKE MANIFOLD RUNNER CONTROL VALVE MOTOR POWER SUPPLY

1. Turn ignition switch ON.
2. Check the voltage between ECM harness connector.

ECM				Voltage
+		-		
Connector	Terminal	Connector	Terminal	
F52	50	E16	128	Battery voltage

# P2004 INTAKE MANIFOLD RUNNER CONTROL VALVE

[QR25DE]

< DTC/CIRCUIT DIAGNOSIS >

Is the inspection result normal?

- YES >> GO TO 3.
- NO >> GO TO 2.

## 2.CHECK INTAKE MANIFOLD RUNNER CONTROL VALVE MOTOR POWER SUPPLY CIRCUIT

1. Turn ignition switch OFF.
2. Disconnect ECM harness connector.
3. Disconnect IPDM E/R harness connector.
4. Check the continuity between ECM harness connector and IPDM E/R harness connector.

+		-		Continuity
ECM		IPDM E/R		
Connector	Terminal	Connector	Terminal	
F52	50	E119	8	Existed

5. Also check harness for short to ground.

Is the inspection result normal?

- YES >> Perform the trouble diagnosis for power supply circuit.
- NO >> Repair or replace error-detected parts.

## 3.CHECK INTAKE MANIFOLD RUNNER CONTROL VALVE MOTOR OUTPUT SIGNAL CIRCUIT

1. Disconnect intake manifold runner control valve motor harness connector.
2. Check the continuity between intake manifold runner control valve motor harness connector and ECM harness connector.

+		-		Continuity
Intake manifold runner control valve motor		ECM		
Connector	Terminal	Connector	Terminal	
F19	1	F52	49	Not existed
			51	Existed
	2		49	Existed
			51	Not existed

3. Also check harness for short to ground and to power.

Is the inspection result normal?

- YES >> GO TO 4.
- NO >> Repair or replace error-detected parts.

## 4.CHECK INTAKE MANIFOLD RUNNER CONTROL VALVE MOTOR

Check the intake manifold runner control valve motor. Refer to [EC-424, "Component Inspection"](#).

Is the inspection result normal?

- YES >> GO TO 5.
- NO >> Replace intake manifold assembly. Refer to [EM-29, "Removal and Installation"](#).

## 5.CHECK INTERMITTENT INCIDENT

Refer to [GI-44, "Intermittent Incident"](#).

>> INSPECTION END

## Component Inspection

INFOID:0000000011278142

## 1.CHECK INTAKE MANIFOLD RUNNER CONTROL VALVE

### Ⓟ With CONSULT

1. Turn ignition switch ON.
2. Select "DATA MONITOR" mode with CONSULT.



# P2004 INTAKE MANIFOLD RUNNER CONTROL VALVE

[QR25DE]

## < DTC/CIRCUIT DIAGNOSIS >

3. Make sure that "COOLAN TEMP/S" indicates between  $-7^{\circ}\text{C}$  ( $19^{\circ}\text{F}$ ) to  $60^{\circ}\text{C}$  ( $140^{\circ}\text{F}$ ).  
If not, cool engine down or warm engine up until "COOLAN TEMP/S" indicates between  $-7^{\circ}\text{C}$  ( $19^{\circ}\text{F}$ ) to  $60^{\circ}\text{C}$  ( $140^{\circ}\text{F}$ ). Then go to the following steps.
4. Fully release accelerator pedal and make sure that "TUMBLE POS SEN" indicates between 2.8 V to 4.1 V.
5. Depress accelerator pedal and make sure that "TUMBLE POS SEN" indicates between 0.2 V to 1.4 V.
6. Check 1st trip DTC.

### With GST

Following the procedure "With CONSULT" above.

#### Is 1st trip DTC detected?

- YES >> Replace intake manifold assembly. Refer to [EM-29. "Removal and Installation"](#).  
NO >> GO TO 2.

## 2. CHECK INTAKE MANIFOLD RUNNER CONTROL VALVE MOTOR

1. Turn ignition switch OFF.
2. Disconnect intake manifold runner control valve motor harness connector.
3. Check the resistance between intake manifold runner control valve motor terminals as per the following.

Intake manifold runner control valve motor		Resistance (Approx.)
+	-	
Terminals		
1	2	4.64 - 6.30 $\Omega$ [at $25^{\circ}\text{C}$ ( $77^{\circ}\text{F}$ )]

#### Is the inspection result normal?

- YES >> INSPECTION END  
NO >> Replace intake manifold assembly. Refer to [EM-29. "Removal and Installation"](#).

# P2014, P2016, P2017, P2018 INTAKE MANIFOLD RUNNER CONTROL VALVE POSITION SENSOR

< DTC/CIRCUIT DIAGNOSIS >

[QR25DE]

## P2014, P2016, P2017, P2018 INTAKE MANIFOLD RUNNER CONTROL VALVE POSITION SENSOR

### DTC Description

INFOID:000000011278143

### DTC DETECTION LOGIC

DTC No.	CONSULT screen terms (Trouble diagnosis content)	DTC detecting condition
P2014	IN/MANIFOLD RUNNER POS SEN B1 (Intake manifold runner position sensor/ switch circuit bank 1)	An excessively low voltage from the sensor is sent to ECM.
P2016	IN/MANIFOLD RUNNER POS SEN B1 (Intake manifold runner position sensor/ switch circuit low bank 1)	
P2017	IN/MANIFOLD RUNNER POS SEN B1 (Intake manifold runner position sensor/ switch circuit high bank 1)	An excessively high voltage from the sensor is sent to ECM.
P2018	IN/MANIFOLD RUNNER POS SEN B1 (Intake manifold runner position sensor/ switch circuit intermittent bank 1)	

### POSSIBLE CAUSE

- Harness or connectors (Intake manifold runner control position sensor circuit is shorted.)
- Intake manifold runner control position sensor

### FAIL-SAFE

Not applicable

### DTC CONFIRMATION PROCEDURE

#### 1. CHECK DTC PRIORITY

If DTC P2014, P2016, P2017 or P2018 is displayed with DTC P0643, first perform the trouble diagnosis for DTC P0643.

#### Is applicable DTC detected?

YES >> Perform diagnosis of applicable. Refer to [EC-382, "DTC Description"](#).

NO >> GO TO 2.

#### 2. PRECONDITIONING

If DTC Confirmation Procedure has been previously conducted, always perform the following before conducting the next test.

1. Turn ignition switch OFF and wait at least 10 seconds.
2. Turn ignition switch ON.
3. Turn ignition switch OFF and wait at least 10 seconds.

#### **TESTING CONDITION:**

**Before performing the following procedure, confirm that battery voltage is more than 11 V at idle.**

>> GO TO 3.

#### 3. PERFORM DTC CONFIRMATION PROCEDURE

1. Start engine and let it idle for 10 seconds.
2. Check 1st trip DTC.

#### Is 1st trip DTC detected?

YES >> Proceed to [EC-427, "Diagnosis Procedure"](#).

NO >> INSPECTION END

# P2014, P2016, P2017, P2018 INTAKE MANIFOLD RUNNER CONTROL VALVE POSITION SENSOR

< DTC/CIRCUIT DIAGNOSIS >

[QR25DE]

## Diagnosis Procedure

INFOID:0000000011278144

### 1. CHECK DTC PRIORITY

If DTC P2014, P2016, P2017 or P2018 is displayed with DTC P0643, first perform the trouble diagnosis for DTC P0643.

Is applicable DTC detected?

- YES >> Perform diagnosis of applicable. Refer to [EC-382, "DTC Description"](#).
- NO >> GO TO 2.

### 2. CHECK INTAKE MANIFOLD RUNNER CONTROL VALVE POSITION SENSOR POWER SUPPLY

1. Turn ignition switch OFF.
2. Disconnect intake valve manifold runner control valve position sensor harness connector.
3. Turn ignition switch ON.
4. Check the voltage between intake valve manifold runner control valve position sensor harness connector.

Intake manifold runner control valve position sensor			Voltage (Approx.)
Connector	+	-	
		Terminal	
F20	1	3	5 V

Is the inspection result normal?

- YES >> GO TO 5.
- NO >> GO TO 3.

### 3. CHECK INTAKE MANIFOLD RUNNER CONTROL VALVE POSITION SENSOR POWER SUPPLY CIRCUIT

Check the voltage between intake valve manifold runner control valve position sensor harness connector and ground.

+		-	Voltage (Approx.)
Intake manifold runner control valve position sensor			
Connector	Terminal		
F20	1	Ground	5 V

Is the inspection result normal?

- YES >> GO TO 4.
- NO >> Perform the trouble diagnosis for power supply circuit.

### 4. CHECK ECM GROUND CIRCUIT

1. Turn ignition switch OFF.
2. Disconnect ECM harness connector.
3. Check the continuity between ECM harness connector and ground.

+		-	Continuity
ECM			
Connector	Terminal		
F51	16	Ground	Existed
F52	52		
E16	123		
	128		

4. Also check harness for short to power.

Is the inspection result normal?

- YES >> GO TO 8.

# P2014, P2016, P2017, P2018 INTAKE MANIFOLD RUNNER CONTROL VALVE POSITION SENSOR

[QR25DE]

< DTC/CIRCUIT DIAGNOSIS >

NO >> Repair or replace error-detected parts.

## 5. CHECK INTAKE MANIFOLD RUNNER CONTROL VALVE POSITION SENSOR GROUND CIRCUIT

1. Turn ignition switch OFF.
2. Disconnect ECM harness connector.
3. Check the continuity between intake manifold runner control valve position sensor harness connector and ECM harness connector.

+		-		Continuity
Intake manifold runner control valve position sensor		ECM		
Connector	Terminal	Connector	Terminal	
F20	3	F52	92	Existed

4. Also check harness for short to power.

Is the inspection result normal?

YES >> GO TO 6.

NO >> Repair or replace error-detected parts.

## 6. CHECK INTAKE MANIFOLD RUNNER CONTROL VALVE POSITION SENSOR INPUT SIGNAL CIRCUIT

1. Check the continuity between intake manifold runner control valve position sensor harness connector and ECM harness connector.

+		-		Continuity
Intake manifold runner control valve position sensor		ECM		
Connector	Terminal	Connector	Terminal	
F20	2	F52	83	Existed

2. Also check harness for short to ground and to power.

Is the inspection result normal?

YES >> GO TO 7.

NO >> Repair or replace error-detected parts.

## 7. CHECK INTERMITTENT INCIDENT

Perform [GI-44, "Intermittent Incident"](#).

Is the inspection result normal?

YES >> Replace intake manifold assembly. Refer to [EM-29, "Removal and Installation"](#).

NO >> Repair or replace error-detected parts.

## 8. CHECK INTERMITTENT INCIDENT

Refer to [GI-44, "Intermittent Incident"](#).

>> INSPECTION END

# P2096, P2097 A/F SENSOR 1

< DTC/CIRCUIT DIAGNOSIS >

[QR25DE]

## P2096, P2097 A/F SENSOR 1

### DTC Description

INFOID:0000000011278145

### DTC DETECTION LOGIC

DTC No.	CONSULT screen terms (Trouble diagnosis content)	DTC detecting condition
P2096	POST CATALYST FUEL TRIM SYS B1 (Post catalyst fuel trim system too lean bank 1)	The output voltage computed by ECM from the A/F sensor 1 signal is shifts to the lean side for a specified period.
P2097	POST CATALYST FUEL TRIM SYS B1 (Post catalyst fuel trim system too rich bank 1)	The A/F signal computed by ECM from the A/F sensor 1 signal is shifts to the rich side for a specified period.

### POSSIBLE CAUSE

- A/F sensor 1
- A/F sensor 1 heater
- Heated oxygen sensor 2
- Fuel pressure
- Fuel injector
- Intake air leaks
- Exhaust gas leaks

### FAIL-SAFE

Not applicable

### DTC CONFIRMATION PROCEDURE

#### 1. PRECONDITIONING

If DTC Confirmation Procedure has been previously conducted, always perform the following procedure before conducting the next test.

1. Turn ignition switch OFF and wait least 10 seconds.
2. Turn ignition switch ON.
3. Turn ignition switch OFF and wait least 10 seconds.

#### TESTING CONDITION:

Before performing the following procedure, confirm that battery voltage is more than 11 at idle.

>> GO TO 2.

#### 2. PERFORM DTC CONFIRMATION PROCEDURE

1. Clear the mixture ratio self-learning value. Refer to [EC-146, "Work Procedure"](#).
2. Turn ignition switch OFF and wait at least 10 seconds.
3. Start engine and keep the engine speed between 3,500 and 4,000 rpm for 1 minute under no load.
4. Let engine idle for 1 minute.
5. Keep engine speed between 2,500 and 3,000 rpm for 20 minutes.
6. Check 1st trip DTC.

#### Is 1st trip DTC detected?

- YES >> Proceed to [EC-429, "Diagnosis Procedure"](#).  
NO >> INSPECTION END

### Diagnosis Procedure

INFOID:0000000011278146

#### 1. CHECK HARNESS CONNECTOR

1. Turn ignition switch OFF.
2. Disconnect A/F sensor 1 harness connector.
3. Check harness connector for water.

**Water should not exit.**

# P2096, P2097 A/F SENSOR 1

[QR25DE]

< DTC/CIRCUIT DIAGNOSIS >

Is the inspection result normal?

- YES >> GO TO 2.
- NO >> Repair or replace harness connector.

## 2. RETIGHTEN A/F SENSOR 1 AND HEATED OXYGEN SENSOR 2

Loosen and retighten the A/F sensor 1 and heated oxygen sensor 2. Refer to [EM-32, "Exploded View"](#), [EX-5, "Exploded View"](#).

>> GO TO 3.

## 3. CHECK FOR EXHAUST GAS LEAK

1. Start engine and run it at idle.
2. Listen for an exhaust gas leak before the three way catalyst 2.

Is exhaust gas leak detected?

- YES >> Repair or replace malfunctioning parts.
- NO >> GO TO 4.

## 4. CHECK FOR INTAKE AIR LEAK

1. Reconnect A/F sensor 1 harness connector.
2. Start engine and run it at idle.
3. Listen for an intake air leak after the mass air flow sensor.

Is intake air leak detected?

- YES >> Repair or replace malfunctioning parts.
- NO >> GO TO 5.

## 5. CLEAR THE MIXTURE RATIO SELF-LEARNING VALUE

1. Clear the mixture ratio self-learning value. Refer to [EC-146, "Work Procedure"](#).
2. Run engine for at least 10 minutes at idle speed.

Is the 1st trip DTC P0171 or P0172 detected? Is it difficult to start engine?

- YES >> Perform trouble diagnosis for DTC P0171 or P0172. Refer to [EC-263, "DTC Description"](#) or [EC-268, "DTC Description"](#).
- NO >> GO TO 6.

## 6. CHECK A/F SENSOR 1 POWER SUPPLY

1. Turn ignition switch OFF.
2. Disconnect A/F sensor 1 harness connector.
3. Turn ignition switch ON.
4. Check the voltage between A/F sensor 1 harness connector and ground.

+		-	Voltage
A/F sensor 1			
Connector	Terminal		
F18	4	Ground	Battery voltage

Is the inspection result normal?

- YES >> GO TO 8.
- NO >> GO TO 7.

## 7. CHECK A/F SENSOR 1 POWER SUPPLY CIRCUIT

1. Turn ignition switch OFF.
2. Disconnect IPDM E/R harness connector.
3. Check the continuity between A/F sensor 1 harness connector and IPDM E/R harness connector.

# P2096, P2097 A/F SENSOR 1

[QR25DE]

## < DTC/CIRCUIT DIAGNOSIS >

+		-		Continuity
A/F sensor 1		IPDM E/R		
Connector	Terminal	Connector	Terminal	
F18	4	F35	75	Existed

4. Also check harness for short to ground.

Is the inspection result normal?

YES >> Perform the trouble diagnosis for power supply circuit.

NO >> Repair or replace error-detected parts.

## 8. CHECK A/F SENSOR 1 INPUT SIGNAL CIRCUIT

1. Turn ignition switch OFF.
2. Disconnect ECM harness connector.
3. Check the continuity between A/F sensor 1 harness connector and ECM harness connector.

+		-		Continuity
A/F sensor 1		ECM		
Connector	Terminal	Connector	Terminal	
F18	1	F51	41	Existed
	2		45	

4. Check the continuity between A/F sensor 1 harness connector and ground, or ECM harness connector and ground.

+		-		Continuity
A/F sensor 1		Ground		
Connector	Terminal			
F18	1	Ground		Not existed
	2			

+		-		Continuity
ECM		Ground		
Connector	Terminal			
F51	41	Ground		Not existed
	45			

5. Also check harness for short to power.

Is the inspection result normal?

YES >> GO TO 9.

NO >> Repair or replace error-detected parts.

## 9. CHECK A/F SENSOR 1 HEATER

Check the A/F sensor 1 heater. Refer to [EC-189. "Component Inspection"](#).

Is the inspection result normal?

YES >> GO TO 10.

NO >> GO TO 12.

## 10. CHECK HEATED OXYGEN SENSOR 2

Check heated oxygen sensor 2. Refer to [EC-242. "Component Inspection"](#).

Is the inspection result normal?

YES >> GO TO 11.

NO >> Replace heated oxygen sensor 2. Refer to [EX-5. "Exploded View"](#).

< DTC/CIRCUIT DIAGNOSIS >

---

## 11. CHECK INTERMITTENT INCIDENT

---

Perform [GI-44, "Intermittent Incident"](#).

Is the inspection result normal?

YES >> GO TO 12.

NO >> Repair or replace error-detected parts.

---

## 12. REPLACE AIR FUEL RATIO (A/F) SENSOR 1

---

Replace air fuel ratio (A/F) sensor 1. Refer to [EM-32, "Exploded View"](#).

**CAUTION:**

- Discard any sensor which has been dropped from a height of more than 0.5 m (19.7 in) onto a hard surface such as a concrete floor; use a new one.
- Before installing new sensor, clean exhaust system threads using Oxygen Sensor Thread Cleaner [commercial service tool (J-43897-18 or J-43897-12)] and approved Anti-seize Lubricant (commercial service tool).

Do you have CONSULT?

YES >> GO TO 13.

NO >> GO TO 14.

---

## 13. CONFIRM A/F ADJUSTMENT DATA

---

Ⓜ With CONSULT

1. Turn ignition switch ON.
2. Select "A/F ADJ-B1" in "DATA MONITOR" mode of "ENGINE" using CONSULT.
3. Make sure that "0.000" is displayed on CONSULT screen.

Is "0.000" displayed?

YES >> INSPECTION END

NO >> GO TO 14.

---

## 14. CLEAR THE MIXTURE RATIO SELF-LEARNING VALUE

---

Clear the mixture ratio self-learning value. Refer to [EC-146, "Work Procedure"](#).

Do you have CONSULT?

YES >> GO TO 15.

NO >> INSPECTION END

---

## 15. CONFIRM A/F ADJUSTMENT DATA

---

Ⓜ With CONSULT

1. Turn ignition switch ON.
2. Select "A/F ADJ-B1" in "DATA MONITOR" mode of "ENGINE" using CONSULT.
3. Make sure that "0.000" is displayed on CONSULT screen.

>> INSPECTION END



# P2100, P2103 THROTTLE CONTROL MOTOR RELAY

< DTC/CIRCUIT DIAGNOSIS >

[QR25DE]

## P2100, P2103 THROTTLE CONTROL MOTOR RELAY

### DTC Description

INFOID:0000000011278147

### DTC DETECTION LOGIC

DTC No.	CONSULT screen terms (Trouble diagnosis content)	DTC detecting condition
P2100	ETC MOT PWR-B1 (Throttle actuator "A" control motor circuit/ open)	ECM detects a voltage of power source for throttle control motor is excessively low.
P2103	ETC MOT PWR-B1 (Throttle actuator "A" control motor circuit high)	ECM detect the throttle control motor relay is stuck ON.

### POSSIBLE CAUSE

#### DTC P2100

- Harness or connectors (Throttle control motor relay circuit is open.)
- Throttle control motor relay

#### DTC P2103

- Harness or connectors (Throttle control motor relay circuit is shorted.)
- Throttle control motor relay

### FAIL-SAFE

ECM stops the electric throttle control actuator control, throttle valve is maintained at a fixed opening (approx. 5 degrees) by the return spring.

### DTC CONFIRMATION PROCEDURE

#### 1. PRECONDITIONING

If DTC Confirmation Procedure has been previously conducted, always perform the following procedure before conducting the next test.

1. Turn ignition switch OFF and wait at least 10 seconds.
2. Turn ignition switch ON.
3. Turn ignition switch OFF and wait at least 10 seconds.

#### TESTING CONDITION:

**Before performing the following procedure, confirm that battery voltage is more than 8 V.**

#### With DTC is detected?

- P2100 >> GO TO 2.
- P2103 >> GO TO 3.

#### 2. PERFORM DTC CONFIRMATION PROCEDURE FOR DTC P2100

1. Turn ignition switch ON and wait at least 2 seconds.
2. Start engine and let it idle for 5 seconds.
3. Check DTC.

#### Is DTC detected?

- YES >> Proceed to [EC-434, "Diagnosis Procedure"](#).
- NO >> INSPECTION END

#### 3. PERFORM DTC CONFIRMATION PROCEDURE FOR DTC P2103

1. Turn ignition switch ON and wait at least 1 second.
2. Check DTC.

#### Is DTC detected?

- YES >> Proceed to [EC-434, "Diagnosis Procedure"](#).
- NO >> INSPECTION END

# P2100, P2103 THROTTLE CONTROL MOTOR RELAY

< DTC/CIRCUIT DIAGNOSIS >

[QR25DE]

INFOID:000000011278148

## Diagnosis Procedure

### 1. CHECK THROTTLE CONTROL MOTOR RELAY POWER SUPPLY

1. Turn ignition switch OFF.
2. Check the voltage between ECM harness connector and ground.

+		-		Voltage
ECM				
Connector	Terminal	Connector	Terminal	
F51	2	E16	128	Battery voltage

Is the inspection result normal?

YES >> GO TO 3.

NO >> GO TO 2.

### 2. CHECK THROTTLE CONTROL MOTOR RELAY POWER SUPPLY CIRCUIT

1. Disconnect ECM harness connector.
2. Disconnect IPDM E/R harness connector.
3. Check the continuity between ECM harness connector and IPDM E/R harness connector.

+		-		Continuity
ECM		IPDM E/R		
Connector	Terminal	Connector	Terminal	
F51	2	F35	72	Existed

4. Also check harness for short to ground.

Is the inspection result normal?

YES >> Perform the trouble diagnosis for power supply circuit.

NO >> Repair or replace error-detected parts.

### 3. CHECK THROTTLE CONTROL MOTOR RELAY INPUT SIGNAL

Check the voltage between ECM harness connector and ground as per the following conditions.

ECM				Condition	Voltage (Approx.)
+		-			
Connector	Terminal	Connector	Terminal		
F51	21	E16	128	Ignition switch: OFF	0 V
				Ignition switch: ON	Battery voltage

Is the inspection result normal?

YES >> GO TO 5.

NO >> GO TO 4.

### 4. CHECK THROTTLE CONTROL MOTOR RELAY INPUT SIGNAL CIRCUIT

1. Turn ignition switch OFF.
2. Disconnect ECM harness connector.
3. Disconnect IPDM E/R harness connector.
4. Check the continuity between ECM harness connector and IPDM E/R harness connector.

+		-		Continuity
ECM		IPDM E/R		
Connector	Terminal	Connector	Terminal	
F51	21	F35	67	Existed

5. Also check harness for short to ground and to power.

# P2100, P2103 THROTTLE CONTROL MOTOR RELAY

< DTC/CIRCUIT DIAGNOSIS >

[QR25DE]

Is the inspection result normal?

YES >> GO TO 5.

NO >> Repair or replace error-detected parts.

## 5.CHECK INTERMITTENT INCIDENT

Refer to [GI-44. "Intermittent Incident"](#).

>> INSPECTION END

A

EC

C

D

E

F

G

H

I

J

K

L

M

N

O

P

# P2101 ELECTRIC THROTTLE CONTROL FUNCTION

< DTC/CIRCUIT DIAGNOSIS >

[QR25DE]

## P2101 ELECTRIC THROTTLE CONTROL FUNCTION

### DTC Description

INFOID:000000011278149

### DTC DETECTION LOGIC

DTC No.	CONSULT screen terms (Trouble diagnosis content)	DTC detecting condition
P2101	ETC FNCTN/CIRC-B1 (Throttle actuator "A" control motor circuit range/performance)	Electric throttle control function does not operate properly.

### POSSIBLE CAUSE

- Harness or connectors (Throttle control motor circuit is open or shorted.)
- Electric throttle control actuator

### FAIL-SAFE

ECM stops the electric throttle control actuator control, throttle valve is maintained at a fixed opening (approx. 5 degrees) by the return spring.

### DTC CONFIRMATION PROCEDURE

#### 1.CHECK DTC PRIORITY

If DTC P2101 is displayed with DTC P2100 or P2119, first perform the trouble diagnosis for DTC P2100 or P2119.

#### Is applicable DTC detected?

- YES >> Perform diagnosis of applicable. Refer to [EC-96, "DTC Index"](#).  
NO >> GO TO 2.

#### 2.PRECONDITIONING

If DTC Confirmation Procedure has been previously conducted, always perform the following procedure before conducting the next test.

1. Turn ignition switch OFF and wait at least 10 seconds.
2. Turn ignition switch ON.
3. Turn ignition switch OFF and wait at least 10 seconds.

#### **TESTING CONDITION:**

**Before performing the following procedure, confirm that battery voltage is more than 11 V when engine is running.**

>> GO TO 3.

#### 3.PERFORM DTC CONFIRMATION PROCEDURE

1. Turn ignition switch ON and wait at least 2 seconds.
2. Start engine and let it idle for 5 seconds.
3. Check DTC.

#### Is DTC detected?

- YES >> Proceed to [EC-436, "Diagnosis Procedure"](#).  
NO >> INSPECTION END

### Diagnosis Procedure

INFOID:000000011278150

#### 1.CHECK DTC PRIORITY

If DTC P2101 is displayed with DTC P2100 or P2119, first perform the trouble diagnosis for DTC P2100 or P2119.

#### Is applicable DTC detected?

- YES >> Perform diagnosis of applicable. Refer to [EC-96, "DTC Index"](#).  
NO >> GO TO 2.

#### 2.CHECK THROTTLE CONTROL MOTOR RELAY INPUT SIGNAL

# P2101 ELECTRIC THROTTLE CONTROL FUNCTION

< DTC/CIRCUIT DIAGNOSIS >

[QR25DE]

Check the voltage between ECM harness connector terminals as per the following conditions.

ECM				Condition	Voltage (Approx.)
+		-			
Connector	Terminal	Connector	Terminal		
F51	21	E16	128	Ignition switch: OFF	0 V
				Ignition switch: ON	Battery voltage

Is the inspection result normal?

YES >> GO TO 5.

NO >> GO TO 3.

## 3. CHECK THROTTLE CONTROL MOTOR RELAY POWER SUPPLY CIRCUIT

1. Check the continuity between ECM harness connector and IPDM E/R harness connector.

+		-		Continuity
ECM		IPDM E/R		
Connector	Terminal	Connector	Terminal	
F51	2	F35	72	Existed

2. Also check harness for short to ground.

Is the inspection result normal?

YES >> GO TO 4.

NO >> Repair or replace error-detected parts.

## 4. CHECK THROTTLE CONTROL MOTOR RELAY INPUT SIGNAL CIRCUIT

- Turn ignition switch OFF.
- Disconnect ECM harness connector.
- Disconnect IPDM E/R harness connector.
- Check the continuity between ECM harness connector and IPDM E/R harness connector.

+		-		Continuity
ECM		IPDM E/R		
Connector	Terminal	Connector	Terminal	
F51	21	F35	67	Existed

5. Also check harness for short to ground and to power.

Is the inspection result normal?

YES >> Perform the trouble diagnosis for power supply circuit.

NO >> Repair or replace error-detected parts.

## 5. CHECK THROTTLE CONTROL MOTOR OUTPUT SIGNAL CIRCUIT

- Turn ignition switch OFF.
- Disconnect electric throttle control actuator harness connector.
- Disconnect ECM harness connector.
- Check the continuity between electric throttle control actuator harness connector and ECM harness connector.

# P2101 ELECTRIC THROTTLE CONTROL FUNCTION

< DTC/CIRCUIT DIAGNOSIS >

[QR25DE]

+		-		Continuity
Electric throttle control actuator		ECM		
Connector	Terminal	Connector	Terminal	
F50	5	F51	1	Existed
			3	Not existed
	6		1	Not existed
			3	Existed

5. Also check harness for short to ground and to power.

Is the inspection result normal?

YES >> GO TO 6.

NO >> Repair or replace error-detected parts.

## 6. CHECK ELECTRIC THROTTLE CONTROL ACTUATOR VISUALLY

1. Remove the intake air duct. Refer to [EM-26, "Exploded View"](#).

2. Check if foreign matter is caught between the throttle valve and the housing.

Is the inspection result normal?

YES >> GO TO 7.

NO >> Remove the foreign matter and clean the electric throttle control actuator inside, then perform throttle valve closed position learning. Refer to [EC-143, "Work Procedure"](#).

## 7. CHECK THROTTLE CONTROL MOTOR

Check the throttle control motor. Refer to [EC-438, "Component Inspection"](#).

Is the inspection result normal?

YES >> GO TO 8.

NO >> Replace electric throttle control actuator. Refer to [EM-29, "Removal and Installation"](#).

## 8. CHECK INTERMITTENT INCIDENT

Refer to [GI-44, "Intermittent Incident"](#).

>> INSPECTION END

## Component Inspection

INFOID:000000011278151

### 1. CHECK THROTTLE CONTROL MOTOR

1. Turn ignition switch OFF.

2. Disconnect electric throttle control actuator harness connector.

3. Check the resistance between electric throttle control actuator terminals as per the following.

Electric throttle control actuator		Resistance (Approx.)
+	-	
Terminals		
5	6	1 - 15 Ω [at 25°C (77°F)]

Is the inspection result normal?

YES >> INSPECTION END

NO >> Replace electric throttle control actuator. Refer to [EM-29, "Removal and Installation"](#).

# P2118 THROTTLE CONTROL MOTOR

< DTC/CIRCUIT DIAGNOSIS >

[QR25DE]

## P2118 THROTTLE CONTROL MOTOR

### DTC Description

INFOID:000000011278152

### DTC DETECTION LOGIC

DTC No.	CONSULT screen terms (Trouble diagnosis content)	DTC detecting condition
P2118	ETC MOT-B1 (Throttle actuator control motor current range/performance)	ECM detects short in both circuits between ECM and throttle control motor.

### POSSIBLE CAUSE

- Harness or connectors (Throttle control motor circuit is shorted.)
- Electric throttle control actuator (Throttle control motor)

### FAIL-SAFE

ECM stops the electric throttle control actuator control, throttle valve is maintained at a fixed opening (approx. 5 degrees) by the return spring.

### DTC CONFIRMATION PROCEDURE

#### 1. PRECONDITIONING

If DTC Confirmation Procedure has been previously conducted, always perform the following procedure before conducting the next test.

1. Turn ignition switch OFF and wait at least 10 seconds.
2. Turn ignition switch ON.
3. Turn ignition switch OFF and wait at least 10 seconds.

>> GO TO 2.

#### 2. PERFORM DTC CONFIRMATION PROCEDURE

1. Turn ignition switch ON and wait at least 2 seconds.
2. Start engine and let it idle for 5 seconds.
3. Check DTC.

#### Is DTC detected?

- YES >> Proceed to [EC-439. "Diagnosis Procedure"](#).  
NO >> INSPECTION END

### Diagnosis Procedure

INFOID:000000011278153

#### 1. CHECK THROTTLE CONTROL MOTOR OUTPUT SIGNAL CIRCUIT

1. Turn ignition switch OFF.
2. Disconnect electric throttle control actuator harness connector.
3. Disconnect ECM harness connector.
4. Check the continuity between electric throttle control actuator harness connector and ECM harness connector.

+		-		Continuity
Electric throttle control actuator		ECM		
Connector	Terminal	Connector	Terminal	
F50	5	F51	1	Existed
			3	Not existed
	6		1	Not existed
			3	Existed

5. Also check harness for short to ground and to power.

# P2118 THROTTLE CONTROL MOTOR

[QR25DE]

< DTC/CIRCUIT DIAGNOSIS >

Is the inspection result normal?

- YES >> GO TO 2.
- NO >> Repair or replace error-detected parts.

## 2.CHECK THROTTLE CONTROL MOTOR

Check the throttle control motor. Refer to [EC-440, "Component Inspection"](#).

Is the inspection result normal?

- YES >> GO TO 3.
- NO >> Replace electric throttle control actuator. Refer to [EM-29, "Removal and Installation"](#).

## 3.CHECK INTERMITTENT INCIDENT

Refer to [GI-44, "Intermittent Incident"](#).

>> INSPECTION END

## Component Inspection

INFOID:0000000011278154

## 1.CHECK THROTTLE CONTROL MOTOR

1. Turn ignition switch OFF.
2. Disconnect electric throttle control actuator harness connector.
3. Check the resistance between electric throttle control actuator terminals as per the following.

Electric throttle control actuator		Resistance (Approx.)
+	-	
Terminals		
5	6	1 - 15 $\Omega$ [at 25°C (77°F)]

Is the inspection result normal?

- YES >> INSPECTION END
- NO >> Replace electric throttle control actuator. Refer to [EM-29, "Removal and Installation"](#).



# P2119 ELECTRIC THROTTLE CONTROL ACTUATOR

< DTC/CIRCUIT DIAGNOSIS >

[QR25DE]

## P2119 ELECTRIC THROTTLE CONTROL ACTUATOR

### DTC Description

INFOID:000000011278155

### DTC DETECTION LOGIC

DTC No.	CONSULT screen terms (Trouble diagnosis content)	DTC detecting condition	
P2119	ETC ACTR-B1 (Throttle actuator control throttle body range/performance)	A	Electric throttle control actuator does not function properly due to the return spring malfunction.
		B	Throttle valve opening angle in fail-safe mode is not in specified range.
		C	ECM detect the throttle valve is stuck open.

### POSSIBLE CAUSE

Electric throttle control actuator

### FAIL-SAFE

Traveling control mode (Engine output control)

### DTC CONFIRMATION PROCEDURE

#### 1. PRECONDITIONING

If DTC Confirmation Procedure has been previously conducted, always perform the following procedure before conducting the next test.

1. Turn ignition switch OFF and wait at least 10 seconds.
2. Turn ignition switch ON.
3. Turn ignition switch OFF and wait at least 10 seconds.

>> GO TO 2.

#### 2. PERFORM DTC CONFIRMATION PROCEDURE FOR MALFUNCTION A AND B

1. Turn ignition switch ON and wait at least 1 second.
2. Set selector lever to D position and wait at least 3 seconds.
3. Set selector lever to P position.
4. Turn ignition switch OFF and wait at least 10 seconds.
5. Turn ignition switch ON and wait at least 1 second.
6. Set selector lever to D position and wait at least 3 seconds.
7. Set selector lever to P position.
8. Turn ignition switch OFF, wait at least 10 seconds and then turn ON.
9. Check DTC.

#### Is DTC detected?

- YES >> Proceed to [EC-441. "Diagnosis Procedure"](#).  
NO >> GO TO 3.

#### 3. PERFORM DTC CONFIRMATION PROCEDURE FOR MALFUNCTION C

1. Turn ignition switch ON and wait at least 1 second.
2. Set selector lever to D position and wait at least 3 seconds.
3. Set selector lever to P position.
4. Start engine and let it idle for 3 seconds.
5. Check DTC.

#### Is DTC detected?

- YES >> Proceed to [EC-441. "Diagnosis Procedure"](#).  
NO >> INSPECTION END

### Diagnosis Procedure

INFOID:000000011278156

#### 1. CHECK ELECTRIC THROTTLE CONTROL ACTUATOR VISUALLY

1. Remove the intake air duct. Refer to [EM-26. "Exploded View"](#).

## P2119 ELECTRIC THROTTLE CONTROL ACTUATOR

< DTC/CIRCUIT DIAGNOSIS >

[QR25DE]

2. Check if foreign matter is caught between the throttle valve and the housing.

Is the inspection result normal?

YES >> Replace electric throttle control actuator. Refer to [EM-29, "Removal and Installation"](#).

NO >> Remove the foreign matter and clean the electric throttle control actuator inside, then perform throttle valve closed position learning. Refer to [EC-143, "Work Procedure"](#).

# P2122, P2123 APP SENSOR

< DTC/CIRCUIT DIAGNOSIS >

[QR25DE]

## P2122, P2123 APP SENSOR

### DTC Description

INFOID:000000011278157

### DTC DETECTION LOGIC

DTC No.	CONSULT screen terms (Trouble diagnosis content)	DTC detecting condition
P2122	APP SEN 1/CIRC (Throttle/pedal position sensor/switch "D" circuit low)	An excessively low voltage from the APP sensor 1 is sent to ECM.
P2123	APP SEN 1/CIRC (Throttle/pedal position sensor/switch "D" circuit high)	An excessively high voltage from the APP sensor 1 is sent to ECM.

### POSSIBLE CAUSE

- Harness or connectors (APP sensor 1 circuit is open or shorted.)
- Accelerator pedal position sensor (APP sensor 1)

### FAIL-SAFE

- The ECM controls the electric throttle control actuator in regulating the throttle opening in order for the idle position to be within +10 degrees.
- The ECM regulates the opening speed of the throttle valve to be slower than the normal condition. So, the acceleration will be poor.

### DTC CONFIRMATION PROCEDURE

#### 1.CHECK DTC PRIORITY

If DTC P2122 or P2123 is displayed with DTC P0643, first perform the trouble diagnosis for DTC P0643.

#### Is applicable DTC detected?

- YES >> Perform diagnosis of applicable. Refer to [EC-382, "DTC Description"](#).  
NO >> GO TO 2.

#### 2.PRECONDITIONING

If DTC Confirmation Procedure has been previously conducted, always perform the following procedure before conducting the next test.

1. Turn ignition switch OFF and wait at least 10 seconds.
2. Turn ignition switch ON.
3. Turn ignition switch OFF and wait at least 10 seconds.

#### **TESTING CONDITION:**

**Before performing the following procedure, confirm that battery voltage is more than 8 V at idle.**

>> GO TO 3.

#### 3.PERFORM DTC CONFIRMATION PROCEDURE

1. Start engine and let it idle for 1 second.
2. Check DTC.

#### Is DTC detected?

- YES >> Proceed to [EC-443, "Diagnosis Procedure"](#).  
NO >> INSPECTION END

### Diagnosis Procedure

INFOID:000000011278158

#### 1.CHECK DTC PRIORITY

If DTC P2122 or P2123 is displayed with DTC P0643, first perform the trouble diagnosis for DTC P0643.

#### Is applicable DTC detected?

- YES >> Perform diagnosis of applicable. Refer to [EC-382, "DTC Description"](#).  
NO >> GO TO 2.

# P2122, P2123 APP SENSOR

[QR25DE]

< DTC/CIRCUIT DIAGNOSIS >

## 2. CHECK APP SENSOR 1 POWER SUPPLY

1. Turn ignition switch OFF.
2. Disconnect accelerator pedal position (APP) sensor harness connector.
3. Turn ignition switch ON.
4. Check the voltage between APP sensor harness connector and ground.

+		-	Voltage (Approx.)
APP sensor			
Connector	Terminal	Ground	5 V
E25	4		

Is the inspection result normal?

YES >> GO TO 4.

NO >> GO TO 3.

## 3. CHECK APP SENSOR 1 POWER SUPPLY CIRCUIT

1. Turn ignition switch OFF.
2. Disconnect ECM harness connector.
3. Check the continuity between APP sensor harness connector and ECM harness connector.

+		-		Continuity
APP sensor		ECM		
Connector	Terminal	Connector	Terminal	Existed
E25	4	E16	122	

4. Also check harness for short to ground.

Is the inspection result normal?

YES >> Perform the trouble diagnosis for power supply circuit.

NO >> Repair or replace error-detected parts.

## 4. CHECK APP SENSOR 1 GROUND CIRCUIT

1. Turn ignition switch OFF.
2. Disconnect ECM harness connector.
3. Check the continuity between APP sensor harness connector and ECM harness connector.

+		-		Continuity
APP sensor		ECM		
Connector	Terminal	Connector	Terminal	Existed
E25	2	E16	127	

4. Also check harness for short to power.

Is the inspection result normal?

YES >> GO TO 5.

NO >> Repair or replace error-detected parts.

## 5. CHECK APP SENSOR INPUT SIGNAL CIRCUIT

1. Check the continuity between APP sensor harness connector and ECM harness connector.

+		-		Continuity
APP sensor		ECM		
Connector	Terminal	Connector	Terminal	Existed
E25	3	E16	126	

2. Also check harness for short to ground and to power.

Is the inspection result normal?

# P2122, P2123 APP SENSOR

[QR25DE]

< DTC/CIRCUIT DIAGNOSIS >

- YES >> GO TO 6.
- NO >> Repair or replace error-detected parts.

## 6.CHECK APP SENSOR

Check the APP sensor. Refer to [EC-445. "Component Inspection"](#).

Is the inspection result normal?

- YES >> GO TO 7.
- NO >> Replace accelerator pedal assembly. Refer to [ACC-3. "Removal and Installation"](#).

## 7.CHECK INTERMITTENT INCIDENT

Refer to [GI-44. "Intermittent Incident"](#).

>> INSPECTION END

## Component Inspection

INFOID:0000000011278159

### 1.CHECK ACCELERATOR PEDAL POSITION SENSOR

1. Turn ignition switch OFF.
2. Reconnect all harness connectors disconnected.
3. Turn ignition switch ON.
4. Check the voltage between ECM harness connector terminals as per the following condition.

ECM				Condition	Voltage
Connector		+	-		
		Terminal			
Sensor 1	E16	126	127	Fully released	0.5 - 1.0 V
				Fully depressed	4.2 - 4.8 V
Sensor 2		119	120	Fully released	0.25 - 0.5 V
				Fully depressed	2.0 - 2.5 V

Is the inspection result normal?

- YES >> INSPECTION END
- NO >> Replace accelerator pedal assembly. Refer to [ACC-3. "Removal and Installation"](#).

# P2127, P2128 APP SENSOR

< DTC/CIRCUIT DIAGNOSIS >

[QR25DE]

## P2127, P2128 APP SENSOR

### DTC Description

INFOID:000000011278160

### DTC DETECTION LOGIC

DTC No.	CONSULT screen terms (Trouble diagnosis content)	DTC detecting condition
P2127	APP SEN 2/CIRC (Throttle/pedal position sensor/switch "E" circuit low)	An excessively low voltage from the APP sensor 2 is sent to ECM.
P2128	APP SEN 2/CIRC (Throttle/pedal position sensor/switch "E" circuit high)	An excessively high voltage from the APP sensor 2 is sent to ECM.

### POSSIBLE CAUSE

- Harness or connectors (APP sensor 2 circuit is open or shorted.)
- Accelerator pedal position sensor (APP sensor 2)
- Sensor power supply 2 circuit

### FAIL-SAFE

- The ECM controls the electric throttle control actuator in regulating the throttle opening in order for the idle position to be within +10 degrees.
- The ECM regulates the opening speed of the throttle valve to be slower than the normal condition. So, the acceleration will be poor.

### DTC CONFIRMATION PROCEDURE

#### 1. PRECONDITIONING

If DTC Confirmation Procedure has been previously conducted, always perform the following procedure before conducting the next test.

1. Turn ignition switch OFF and wait at least 10 seconds.
2. Turn ignition switch ON.
3. Turn ignition switch OFF and wait at least 10 seconds.

#### TESTING CONDITION:

**Before performing the following procedure, confirm that battery voltage is more than 8 V at idle.**

>> GO TO 2.

#### 2. PERFORM DTC CONFIRMATION PROCEDURE

1. Start engine and let it idle for 1 second.
2. Check DTC.

#### Is DTC detected?

- YES >> Proceed to [EC-446, "Diagnosis Procedure"](#).  
NO >> INSPECTION END

### Diagnosis Procedure

INFOID:000000011278161

#### 1. CHECK APP SENSOR 2 POWER SUPPLY

1. Turn ignition switch OFF.
2. Disconnect accelerator pedal position (APP) sensor harness connector.
3. Turn ignition switch ON.
4. Check the voltage between APP sensor harness connector and ground.

+		-	Voltage (Approx.)
APP sensor			
Connector	Terminal		
E25	5	Ground	5 V

# P2127, P2128 APP SENSOR

[QR25DE]

< DTC/CIRCUIT DIAGNOSIS >

Is the inspection result normal?

- YES >> GO TO 3.
- NO >> GO TO 2.

## 2.CHECK SENSOR POWER SUPPLY 2 CIRCUIT

Perform [EC-487, "Diagnosis Procedure"](#).

Is inspection result normal?

- YES >> Perform the trouble diagnosis for power supply circuit.
- NO >> Repair or replace error-detected parts.

## 3.CHECK APP SENSOR 2 GROUND CIRCUIT

1. Turn ignition switch OFF.
2. Disconnect ECM harness connector.
3. Check the continuity between APP sensor harness connector and ECM harness connector.

+		-		Continuity
APP sensor		ECM		
Connector	Terminal	Connector	Terminal	
E25	1	E16	120	Existed

4. Also check harness for short to power.

Is the inspection result normal?

- YES >> GO TO 4.
- NO >> Repair or replace error-detected parts.

## 4.CHECK APP SENSOR 2 INPUT SIGNAL CIRCUIT

1. Check the continuity between APP sensor harness connector and ECM harness connector.

+		-		Continuity
APP sensor		ECM		
Connector	Terminal	Connector	Terminal	
E25	6	E16	119	Existed

2. Also check harness for short to ground and to power.

Is the inspection result normal?

- YES >> GO TO 5.
- NO >> Repair or replace error-detected parts

## 5.CHECK APP SENSOR

Check the APP sensor. Refer to [EC-447, "Component Inspection"](#).

Is the inspection result normal?

- YES >> GO TO 6.
- NO >> Replace accelerator pedal assembly. Refer to [ACC-3, "Removal and Installation"](#).

## 6.CHECK INTERMITTENT INCIDENT

Refer to [GI-44, "Intermittent Incident"](#).

>> INSPECTION END

## Component Inspection

INFOID:0000000011278162

## 1.CHECK ACCELERATOR PEDAL POSITION SENSOR

1. Turn ignition switch OFF.
2. Reconnect all harness connectors disconnected.
3. Turn ignition switch ON.
4. Check the voltage between ECM harness connector terminals as per the following condition.

# P2127, P2128 APP SENSOR

< DTC/CIRCUIT DIAGNOSIS >

[QR25DE]

ECM				Condition	Voltage
Connector		+	-		
		Terminal			
Sensor 1	E16	126	127	Fully released	0.5 - 1.0 V
					Fully depressed
Sensor 2		119	120	Fully released	0.25 - 0.5 V
				Fully depressed	2.0 - 2.5 V

Is the inspection result normal?

YES >> INSPECTION END

NO >> Replace accelerator pedal assembly. Refer to [ACC-3. "Removal and Installation"](#).



# P2135 TP SENSOR

[QR25DE]

< DTC/CIRCUIT DIAGNOSIS >

## P2135 TP SENSOR

### DTC Description

INFOID:000000011278163

### DTC DETECTION LOGIC

DTC No.	CONSULT screen terms (Trouble diagnosis content)	DTC detecting condition
P2135	TP SENSOR-B1 (Throttle/pedal position sensor/switch "A" / "B" voltage correlation)	Rationally incorrect voltage is sent to ECM compared with the signals from TP sensor 1 and TP sensor 2.

### POSSIBLE CAUSE

- Harness or connectors (TP sensor 1 or 2 circuit is open or shorted.)
- Electric throttle control actuator (TP sensor 1 or 2)

### FAIL-SAFE

- The ECM controls the electric throttle control actuator in regulating the throttle opening in order for the idle position to be within +10 degrees.
- The ECM regulates the opening speed of the throttle valve to be slower than the normal condition. So, the acceleration will be poor.

### DTC CONFIRMATION PROCEDURE

#### 1.CHECK DTC PRIORITY

If DTC P2135 is displayed with DTC P0643, first perform the trouble diagnosis for DTC P0643.

#### Is applicable DTC detected?

- YES >> Perform diagnosis of applicable. Refer to [EC-382. "DTC Description"](#).  
NO >> GO TO 2.

#### 2.PRECONDITIONING

If DTC Confirmation Procedure has been previously conducted, always perform the following procedure before conducting the next test.

1. Turn ignition switch OFF and wait at least 10 seconds.
2. Turn ignition switch ON.
3. Turn ignition switch OFF and wait at least 10 seconds.

#### **TESTING CONDITION:**

**Before performing the following procedure, confirm that battery voltage is more than 8 V at idle.**

>> GO TO 3.

#### 3.PERFORM DTC CONFIRMATION PROCEDURE

1. Start engine and let it idle for 1 second.
2. Check DTC.

#### Is DTC detected?

- YES >> Proceed to [EC-449. "Diagnosis Procedure"](#).  
NO >> INSPECTION END

### Diagnosis Procedure

INFOID:000000011278164

#### 1.CHECK DTC PRIORITY

If DTC P2135 is displayed with DTC P0643, first perform the trouble diagnosis for DTC P0643.

#### Is applicable DTC detected?

- YES >> Perform diagnosis of applicable. Refer to [EC-382. "DTC Description"](#).  
NO >> GO TO 2.

#### 2.CHECK THROTTLE POSITION SENSOR POWER SUPPLY

1. Turn ignition switch OFF.
2. Disconnect electric throttle control actuator harness connector.

# P2135 TP SENSOR

[QR25DE]

## < DTC/CIRCUIT DIAGNOSIS >

3. Turn ignition switch ON.
4. Check the voltage between electric throttle control actuator harness connector and ground.

+		-	Voltage (Approx.)
Electric throttle control actuator	Connector		
	Terminal	Ground	5 V
F50	2		

Is the inspection result normal?

- YES >> GO TO 4.  
NO >> GO TO 3.

### 3.CHECK THROTTLE POSITION SENSOR POWER SUPPLY CIRCUIT

1. Turn ignition switch OFF.
2. Disconnect ECM harness connector.
3. Check the continuity between electric throttle control actuator harness connector and ground.

+		-		Continuity
Electric throttle control actuator	Connector	ECM	Terminal	
	Terminal	Connector	Terminal	Existed
F50	2	F52	80	

4. Also check harness for short to ground.

Is the inspection result normal?

- YES >> Perform the trouble diagnosis for power supply circuit.  
NO >> Repair or replace error-detected parts.

### 4.CHECK THROTTLE POSITION SENSOR GROUND CIRCUIT

1. Turn ignition switch OFF.
2. Disconnect ECM harness connector.
3. Check the continuity between electric throttle control actuator harness connector and ECM harness connector.

+		-		Continuity
Electric throttle control actuator	Connector	ECM	Terminal	
	Terminal	Connector	Terminal	Existed
F50	4	F52	78	

4. Also check harness for short to power.

Is the inspection result normal?

- YES >> GO TO 5.  
NO >> Repair or replace error-detected parts.

### 5.CHECK THROTTLE POSITION SENSOR INPUT SIGNAL CIRCUIT

1. Check the continuity between electric throttle control actuator harness connector and ECM harness connector.

+		-		Continuity
Electric throttle control actuator	Connector	ECM	Terminal	
	Terminal	Connector	Terminal	Existed
F50	1	F52	79	
	3		77	

# P2135 TP SENSOR

[QR25DE]

< DTC/CIRCUIT DIAGNOSIS >

2. Also check harness for short to ground and to power.

Is the inspection result normal?

YES >> GO TO 6.

NO >> Repair open circuit or short to ground or short to power in harness or connectors.

## 6. CHECK THROTTLE POSITION SENSOR

Check the throttle position sensor. Refer to [EC-451, "Component Inspection"](#).

Is the inspection result normal?

YES >> GO TO 7.

NO >> Replace electric throttle control actuator. Refer to [EM-29, "Removal and Installation"](#).

## 7. CHECK INTERMITTENT INCIDENT

Refer to [GI-44, "Intermittent Incident"](#).

>> INSPECTION END

## Component Inspection

INFOID:0000000011278165

## 1. CHECK THROTTLE POSITION SENSOR

1. Turn ignition switch OFF.
2. Reconnect all harness connectors disconnected.
3. Perform " Throttle Valve Closed Position Learning". Refer to [EC-143, "Work Procedure"](#).
4. Turn ignition switch ON.
5. Set selector lever to D position.
6. Check the voltage between ECM harness connector terminals as per the following conditions.

ECM				Condition	Voltage
Connector	+	-	Terminal		
Sensor 1	F52	79	78	Fully released	More than 0.36V
				Fully depressed	Less than 4.75V
Sensor 2		77		Fully released	Less than 4.75V
				Fully depressed	More than 0.36V

Is the inspection result normal?

YES >> INSPECTION END

NO >> Replace electric throttle control actuator. Refer to [EM-29, "Removal and Installation"](#).

# P2138 APP SENSOR

[QR25DE]

< DTC/CIRCUIT DIAGNOSIS >

## P2138 APP SENSOR

### DTC Description

INFOID:000000011278166

### DTC DETECTION LOGIC

DTC No.	CONSULT screen terms (Trouble diagnosis content)	DTC detecting condition
P2138	APP SENSOR (Throttle/pedal position sensor/switch "D" / "E" voltage correlation)	Rationally incorrect voltage is sent to ECM compared with the signals from APP sensor 1 and APP sensor 2.

### POSSIBLE CAUSE

- Harness or connectors (APP sensor 1 or 2 circuit is open or shorted.)
- Accelerator pedal position sensor (APP sensor 1 or 2)
- Sensor power supply 2 circuit

### FAIL-SAFE

- The ECM controls the electric throttle control actuator in regulating the throttle opening in order for the idle position to be within +10 degrees.
- The ECM regulates the opening speed of the throttle valve to be slower than the normal condition. So, the acceleration will be poor.

### DTC CONFIRMATION PROCEDURE

#### 1. CHECK DTC PRIORITY

If DTC P2138 is displayed with DTC P0643, first perform the trouble diagnosis for DTC P0643.

#### Is applicable DTC detected?

- YES >> Perform diagnosis of applicable. Refer to [EC-382. "DTC Description"](#).  
NO >> GO TO 2.

#### 2. PRECONDITIONING

If DTC Confirmation Procedure has been previously conducted, always perform the following procedure before conducting the next test.

1. Turn ignition switch OFF and wait at least 10 seconds.
2. Turn ignition switch ON.
3. Turn ignition switch OFF and wait at least 10 seconds.

#### **TESTING CONDITION:**

**Before performing the following procedure, confirm that battery voltage is more than 8 V at idle.**

>> GO TO 3.

#### 3. PERFORM DTC CONFIRMATION PROCEDURE

1. Start engine and let it idle for 1 second.
2. Check DTC.

#### Is DTC detected?

- YES >> Proceed to [EC-452. "Diagnosis Procedure"](#).  
NO >> INSPECTION END

### Diagnosis Procedure

INFOID:000000011278167

#### 1. CHECK DTC PRIORITY

If DTC P2138 is displayed with DTC P0643, first perform the trouble diagnosis for DTC P0643.

#### Is applicable DTC detected?

- YES >> Perform diagnosis of applicable. Refer to [EC-382. "DTC Description"](#).  
NO >> GO TO 2.

#### 2. CHECK APP SENSOR 1 POWER SUPPLY

1. Turn ignition switch OFF.

# P2138 APP SENSOR

[QR25DE]

## < DTC/CIRCUIT DIAGNOSIS >

2. Disconnect accelerator pedal position (APP) sensor harness connector.
3. Turn ignition switch ON.
4. Check the voltage between APP sensor harness connector and ground.

+		-	Voltage (Approx.)
APP sensor			
Connector	Terminal		
E25	4	Ground	5 V

Is the inspection result normal?

- YES >> GO TO 4.  
NO >> GO TO 3.

### 3.CHECK APP SENSOR 1 POWER SUPPLY CIRCUIT

1. Turn ignition switch OFF.
2. Disconnect ECM harness connector.
3. Check the continuity between APP sensor harness connector and ECM harness connector.

+		-		Continuity
APP sensor		ECM		
Connector	Terminal	Connector	Terminal	
E25	4	E16	122	Existed

4. Also check harness for short to ground.

Is the inspection result normal?

- YES >> Perform the trouble diagnosis for power supply circuit.  
NO >> Repair or replace error-detected parts.

### 4.CHECK APP SENSOR 2 POWER SUPPLY

Check the voltage between APP sensor harness connector and ground.

+		-	Voltage (Approx.)
APP sensor			
Connector	Terminal		
E25	5	Ground	5 V

Is the inspection result normal?

- YES >> GO TO 6.  
NO >> GO TO 5.

### 5.CHECK SENSOR POWER SUPPLY 2 CIRCUIT

Perform [EC-487, "Diagnosis Procedure"](#).

Is inspection result normal?

- YES >> Perform the trouble diagnosis for power supply circuit.  
NO >> Repair or replace error-detected parts.

### 6.CHECK APP SENSOR GROUND CIRCUIT

1. Turn ignition switch OFF.
2. Disconnect ECM harness connector.
3. Check the continuity between APP sensor harness connector and ECM harness connector.

# P2138 APP SENSOR

[QR25DE]

## < DTC/CIRCUIT DIAGNOSIS >

+		-		Continuity
APP sensor		ECM		
Connector	Terminal	Connector	Terminal	
E25	1	E16	120	Existed
	2		127	

4. Also check harness for short to power.

Is the inspection result normal?

YES >> GO TO 7.

NO >> Repair or replace error-detected parts.

## 7. CHECK APP SENSOR INPUT SIGNAL CIRCUIT

1. Check the continuity between APP sensor harness connector and ECM harness connector.

+		-		Continuity
APP sensor		ECM		
Connector	Terminal	Connector	Terminal	
E25	3	E16	126	Existed
	6		119	

2. Also check harness for short to ground and to power.

Is the inspection result normal?

YES >> GO TO 8.

NO >> Repair or replace error-detected parts

## 8. CHECK APP SENSOR

Check the APP sensor. Refer to [EC-454. "Component Inspection"](#).

Is the inspection result normal?

YES >> GO TO 9.

NO >> Replace accelerator pedal assembly. Refer to [ACC-3. "Removal and Installation"](#).

## 9. CHECK INTERMITTENT INCIDENT

Refer to [GI-44. "Intermittent Incident"](#).

>> INSPECTION END

## Component Inspection

INFOID:000000011278168

### 1. CHECK ACCELERATOR PEDAL POSITION SENSOR

1. Turn ignition switch OFF.
2. Reconnect all harness connectors disconnected.
3. Turn ignition switch ON.
4. Check the voltage between ECM harness connector terminals as per the following condition.

ECM				Condition	Voltage
Connector	+	-			
	Terminal				
Sensor 1	E16	126	127	Fully released	0.5 - 1.0 V
				Fully depressed	4.2 - 4.8 V
Sensor 2		119	120	Fully released	0.25 - 0.5 V
				Fully depressed	2.0 - 2.5 V

Is the inspection result normal?

# P2138 APP SENSOR

< DTC/CIRCUIT DIAGNOSIS >

[QR25DE]

YES >> INSPECTION END

NO >> Replace accelerator pedal assembly. Refer to [ACC-3, "Removal and Installation"](#).

A

EC

C

D

E

F

G

H

I

J

K

L

M

N

O

P

# P2610 ECM INTERNAL TIMER

[QR25DE]

< DTC/CIRCUIT DIAGNOSIS >

## P2610 ECM INTERNAL TIMER

### Description

INFOID:000000011278169

This ECM contains a timer and measures time between an ignition switch OFF and the next ignition switch ON. This enables the judging of the state of engine cooling at an engine start.

### DTC Description

INFOID:000000011278170

### DTC DETECTION LOGIC

DTC No.	CONSULT screen terms (Trouble diagnosis content)	DTC detecting condition
P2610	ECM/PCM INTERNAL ENG OFF TIMER (ECM/PCM internal engine off timer performance)	<ul style="list-style-type: none"><li>ECM internal engine off timer is malfunctioning.</li><li>The time calculated by ECM based on a descent allowance of engine coolant temperatures during ignition switch OFF is extremely shorter than the time counted by the Engine internal OFF timer.</li></ul>

### POSSIBLE CAUSE

ECM

### FAIL-SAFE

Not applicable

### DTC CONFIRMATION PROCEDURE

#### 1.INSPECTION START

#### It is necessary to erase permanent DTC?

YES >> GO TO 4.

NO >> GO TO 2.

#### 2.PRECONDITIONING

1. Turn ignition switch OFF and wait at least 10 seconds.

2. Turn ignition switch ON.

3. Turn ignition switch OFF and wait at least 10 seconds.

#### **TESTING CONDITION:**

**Before performing the following procedure, confirm that battery voltage is 12 V or more under ignition switch OFF condition.**

>> GO TO 3.

#### 3.PERFORM DTC CONFIRMATION PROCEDURE-I

1. Turn ignition switch ON and wait at least 190 seconds.

2. Check 1st trip DTC.

#### Is 1st trip DTC detected?

YES >> Proceed to [EC-457, "Diagnosis Procedure"](#).

NO >> INSPECTION END

#### 4.PRECONDITIONING

1. Turn ignition switch OFF and wait at least 10 seconds.

2. Turn ignition switch ON.

3. Turn ignition switch OFF and wait at least 10 seconds.

#### **TESTING CONDITION:**

• **Before performing the following procedure, confirm that battery voltage is 12 V or more under ignition switch OFF condition.**

• **Before performing the following procedure, check that fuel level is between 2/8 and 7/8.**

>> GO TO 5.



# P2610 ECM INTERNAL TIMER

[QR25DE]

< DTC/CIRCUIT DIAGNOSIS >

## 5.PERFORM DTC CONFIRMATION PROCEDURE-I

1. Turn ignition switch ON and wait at least 190 seconds.
2. Check 1st trip DTC.

Is 1st trip DTC detected?

- YES >> Proceed to [EC-457, "Diagnosis Procedure"](#).  
NO >> GO TO 6.

## 6.PERFORM DTC CONFIRMATION PROCEDURE-II

### CAUTION:

To start this self-diagnosis, the conditions listed bellow are required to be satisfied. Perform the following steps to satisfy the conditions.

- Engine coolant temperature decrease by 55°C (131°F) or more during the time between an ignition switch OFF (after engine warm-up) and the second ignition switch ON.
- A fuel temperature at the second ignition switch ON is -5°C (23°F) or more and less than 35°C (95°F).
- The temperature difference between engine coolant and fuel is 5°C (41°F) or more.

### NOTE:

This self-diagnosis is not performed if the distance traveled is extremely short.

1. Turn ignition switch ON.
2. Start engine and warm it up to normal operating temperature.
3. Turn ignition switch OFF and soak the vehicle for at least 12 hours.

### CAUTION:

- Never turn ON the ignition switch during soaking.
- Never open the fuel filler cap and perform refueling during soaking.

4. Turn ignition switch ON and wait at least 190 seconds.
5. Check 1st trip DTC.

Is 1st trip DTC detected?

- YES >> Proceed to [EC-457, "Diagnosis Procedure"](#).  
NO >> INSPECTION END

## Diagnosis Procedure

INFOID:000000011278171

## 1.CHECK SELF-DIAGNOSTIC RESULT

check that DTCs related to the fuel system and the cooling system are not detected.

Is the inspection result normal?

- YES >> Check the DTC. Refer to [EC-69, "CONSULT Function"](#).  
NO >> GO TO 2.

## 2.PERFORM DTC CONFIRMATION PROCEDURE

1. Erase DTC.
2. Perform DTC Confirmation Procedure again. Refer to [EC-456, "DTC Description"](#).

Is the 1st trip DTC P2610 displayed again?

- YES >> Replace ECM. Refer to [EC-502, "Removal and Installation"](#).  
NO >> INSPECTION END

# BRAKE PEDAL POSITION SWITCH

< DTC/CIRCUIT DIAGNOSIS >

[QR25DE]

## BRAKE PEDAL POSITION SWITCH

### Component Function Check

INFOID:000000011278172

#### 1. CHECK BRAKE PEDAL POSITION SWITCH FUNCTION

##### With CONSULT

1. Turn ignition switch ON.
2. Select "BRAKE SW1" in "DATA MONITOR" mode with CONSULT.
3. Check "BRAKE SW1" indication as per the following conditions.

Monitor item	Condition		Indication
BRAKE SW1	Brake pedal	Slightly depressed	OFF
		Fully released	ON

##### Without CONSULT

1. Turn ignition switch ON.
2. Check the voltage between ECM harness connector terminals.

ECM			Condition	Voltage
Connector	+	-		
	Terminal			
E16	116	128	Brake pedal Slightly depressed	Approx. 0 V
			Fully released	Battery voltage

Is the inspection result normal?

- YES >> INSPECTION END  
 NO >> Proceed to [EC-458. "Diagnosis Procedure"](#).

### Diagnosis Procedure

INFOID:000000011278173

#### 1. CHECK BRAKE PEDAL POSITION SWITCH POWER SUPPLY CIRCUIT

1. Turn ignition switch OFF.
2. Disconnect brake pedal position switch harness connector.
3. Turn ignition switch ON.
4. Check the voltage between brake pedal position switch harness connector and ground.

+		-	Voltage
Brake pedal position switch			
Connector	Terminal		
E6	1	Ground	Battery voltage

Is the inspection result normal?

- YES >> GO TO 3.  
 NO >> GO TO 2.

#### 2. CHECK BRAKE PEDAL POSITION SWITCH POWER SUPPLY CIRCUIT

1. Turn ignition switch OFF.
2. Disconnect fuse block (J/B) harness connector.
3. Check the continuity between brake pedal position switch harness connector and fuse block (J/B) harness connector.

+		+		Continuity
Brake pedal position switch		Fuse block (J/B)		
Connector	Terminal	Connector	Terminal	
E6	1	M68	16R	Existed

# BRAKE PEDAL POSITION SWITCH

[QR25DE]

< DTC/CIRCUIT DIAGNOSIS >

Is the inspection result normal?

- YES >> Perform the trouble diagnosis for power supply circuit.
- NO >> Repair or replace error-detected parts.

## 3.CHECK BRAKE PEDAL POSITION SWITCH INPUT SIGNAL CIRCUIT

1. Turn ignition switch OFF.
2. Disconnect ECM harness connector.
3. Check the continuity between brake pedal position switch harness connector and ECM harness connector.

+		+		Continuity
Brake pedal position switch		ECM		
Connector	Terminal	Connector	Terminal	
E6	2	E16	116	Existed

4. Also check harness for short to ground and to power.

Is the inspection result normal?

- YES >> GO TO 4.
- NO >> Repair open circuit, short to ground or short to power in harness or connectors.

## 4.CHECK BRAKE PEDAL POSITION SWITCH

Check brake pedal position switch. Refer to [EC-459, "Component Inspection \(Brake Pedal Position Switch\)"](#).

Is the inspection result normal?

- YES >> Check intermittent incident. Refer to [GI-44, "Intermittent Incident"](#).
- NO >> Replace brake pedal position switch. Refer to [BR-20, "Exploded View"](#).

## Component Inspection (Brake Pedal Position Switch)

INFOID:000000011278174

### 1.CHECK BRAKE PEDAL POSITION SWITCH-1

1. Turn ignition switch OFF.
2. Disconnect brake pedal position harness connector.
3. Check the continuity between brake pedal position switch terminals as per the following conditions.

Brake pedal position switch		Condition	Continuity
+	-		
Terminals			
1	2	Fully released	Existed
		Slightly depressed	Not existed

Is the inspection result normal?

- YES >> INSPECTION END
- NO >> GO TO 2.

### 2.CHECK BRAKE PEDAL POSITION SWITCH-2

1. Adjust brake pedal position switch installation. Refer to [BR-15, "Adjustment"](#).
2. Check the continuity between brake pedal position switch terminals as per the following conditions.

Brake pedal position switch		Condition	Continuity
+	-		
Terminals			
1	2	Fully released	Existed
		Slightly depressed	Not existed

Is the inspection result normal?

## BRAKE PEDAL POSITION SWITCH

[QR25DE]

< DTC/CIRCUIT DIAGNOSIS >

---

YES >> INSPECTION END

NO >> Replace brake pedal position switch. Refer to [BR-20, "Exploded View"](#).

# COOLING FAN

< DTC/CIRCUIT DIAGNOSIS >

[QR25DE]

## COOLING FAN

### Component Function Check

INFOID:0000000011278175

#### 1. CHECK COOLING FAN FUNCTION

##### With CONSULT

1. Turn ignition switch ON.
2. Perform "FAN DUTY CONTROL" in "ACTIVE TEST" mode with CONSULT.
3. Make sure that cooling fan speed varies according to the percentage.

Is the inspection result normal?

- YES >> INSPECTION END  
 NO >> Proceed to [EC-461, "Diagnosis Procedure"](#).

### Diagnosis Procedure

INFOID:0000000011278176

#### 1. CHECK COOLING FAN RELAY POWER SUPPLY CIRCUIT

1. Turn ignition switch OFF.
2. Disconnect cooling fan relays-2, -3.
3. Turn ignition switch ON.
4. Check the voltage between cooling fan relays-2, -3 harness connectors and ground.

+		-	Voltage
Cooling fan relay			
Connector	Terminal		
H-2 (cooling fan relay-2)	1	Ground	Battery voltage
H-3 (cooling fan relay-3)			

Is the inspection result normal?

- YES >> GO TO 2.  
 NO >> Perform trouble diagnosis for power supply circuit.

#### 2. CHECK COOLING FAN MOTOR CIRCUIT-1

Check the voltage between cooling fan relays-2, -3 harness connectors and ground.

+		-	Voltage
Cooling fan relay			
Connector	Terminal		
H-2 (cooling fan relay-2)	3	Ground	Battery voltage
H-3 (cooling fan relay-3)			

Is the inspection result normal?

- YES >> GO TO 3.  
 NO >> GO TO 4.

#### 3. CHECK COOLING FAN RELAY OUTPUT SIGNAL CIRCUIT

1. Turn ignition switch OFF.
2. Disconnect IPDM E/R harness connectors.
3. Check the continuity between cooling fan relay-2, -3 harness connectors and IPDM E/R harness connector.

# COOLING FAN

< DTC/CIRCUIT DIAGNOSIS >

[QR25DE]

+		-		Continuity
Cooling fan relay		IPDM E/R		
Connector	Terminal	Connector	Terminal	
H-2 (cooling fan relay-2)	2	F42	107	Existed
H-3 (cooling fan relay-3)			106	

4. Also check harness for short to ground and to power.

Is the inspection result normal?

YES >> GO TO 6.

NO >> Repair or replace error-detected parts.

## 4. CHECK COOLING FAN MOTOR POWER SUPPLY CIRCUIT

1. Disconnect cooling fan motor-1 harness connector.
2. Check the voltage between cooling fan motor-1 harness connector and ground.

+		-	Voltage
Cooling fan motor-1			
Connector	Terminal		
F3	1	Ground	Battery voltage
	2		

Is the inspection result normal?

YES >> GO TO 5.

NO >> Perform trouble diagnosis for power supply circuit.

## 5. CHECK COOLING FAN MOTOR CIRCUIT-2

1. Check the continuity between cooling fan relay-2, -3 harness connectors and cooling fan motor-1, -2 harness connectors.

+		-		Continuity
Cooling fan relay		Cooling fan motor-1		
Connector	Terminal	Connector	Terminal	
H-2 (cooling fan relay-2)	3	F3	3	Existed
			4	
H-3 (cooling fan relay-3)			3	
			4	

2. Also check harness for short to ground and to power.

Is the inspection result normal?

YES >> GO TO 11.

NO >> Repair or replace error-detected parts.

## 6. CHECK COOLING FAN MOTOR CIRCUIT-3

1. Check the continuity between IPDM E/R harness connector and cooling fan motor-2 harness connector.

+		-		Continuity
IPDM E/R		Cooling fan motor-2		
Connector	Terminal	Connector	Terminal	
F41	85	F5	1	Existed
			2	

# COOLING FAN

[QR25DE]

## < DTC/CIRCUIT DIAGNOSIS >

2. Also check harness for short to ground and to power.

Is the inspection result normal?

YES >> GO TO 7.

NO >> Repair or replace error-detected parts.

### 7.CHECK COOLING FAN MOTOR CIRCUIT-4

1. Check the continuity between cooling fan relay-3 harness connectors and ground.

+		-	Continuity
Cooling fan relay-3			
Connector	Terminal		
H-3	5	Ground	Existed

2. Also check harness for short to ground and to power.

Is the inspection result normal?

YES >> GO TO 8.

NO >> Repair or replace error-detected parts.

### 8.CHECK COOLING FAN MOTOR CIRCUIT-5

1. Check the continuity between cooling fan relay--3 harness connectors and cooling fan motor-2 harness connector.

+		-		Continuity
Cooling fan relay-2		Cooling fan motor-2		
Connector	Terminal	Connector	Terminal	
H-2	5	F5	1	Existed
			2	

2. Also check harness for short to ground and to power.

Is the inspection result normal?

YES >> GO TO 9.

NO >> Repair or replace error-detected parts.

### 9.CHECK COOLING FAN MOTOR CIRCUIT-4

1. Check the continuity between cooling fan motor-2 harness connector and ground.

+		-	Continuity
Cooling fan motor-2			
Connector	Terminal		
F5	3	Ground	Existed
	4		

2. Also check harness for short to ground and to power.

Is the inspection result normal?

YES >> GO TO 10.

NO >> Repair or replace error-detected parts.

### 10.CHECK COOLING FAN RELAY-2 AND -3

Refer to [EC-464, "Component Inspection \(Cooling Fan Relay\)".](#)

Is the inspection result normal?

YES >> GO TO 11.

NO >> Replace malfunctioning cooling fan relay.

### 11.CHECK COOLING FAN MOTORS-1 AND -2

Refer to [EC-464, "Component Inspection \(Cooling Fan Motor\)".](#)

A

EC

C

D

E

F

G

H

I

J

K

L

M

N

O

P

# COOLING FAN

[QR25DE]

< DTC/CIRCUIT DIAGNOSIS >

Is the inspection result normal?

YES >> GO TO 12.

NO >> Replace malfunctioning cooling fan motor. Refer to [CO-17, "Removal and Installation"](#).

## 12.CHECK INTERMITTENT INCIDENT

Perform [GI-44, "Intermittent Incident"](#).

Is the inspection result normal?

YES >> Replace IPDM E/R. Refer to [PCS-40, "Removal and Installation"](#).

NO >> Repair or replace error-detected parts.

## Component Inspection (Cooling Fan Motor)

INFOID:0000000011278177

### 1.CHECK COOLING FAN MOTOR

1. Turn ignition switch OFF.
2. Disconnect cooling fan motor harness connector.
3. Supply cooling fan motor terminals with battery voltage and check operation.

Cooling fan motor		Condition
Terminal		
+	-	
1	3 and 4	A
2	3 and 4	
1 and 2	3	
1 and 2	4	
1, 2	3, 4	B

**Check that cooling fan speed of condition B is higher than that of A.**

Is the inspection result normal?

YES >> INSPECTION END

NO >> Replace cooling fan motor. Refer to [CO-17, "Removal and Installation"](#).

## Component Inspection (Cooling Fan Relay)

INFOID:0000000011278178

### 1.CHECK COOLING FAN RELAYS

1. Turn ignition switch OFF.
2. Remove cooling fan relay-2, -3.
3. Check the continuity between cooling fan relay-2, -3 terminals as per the following conditions.

Cooling fan relay-2, -3		Conditions	Continuity
+	-		
Terminal			
3	5	12V direct current supply between terminals 1 and 2	Existed
		No current supply	Not existed

Is the inspection result normal?

YES >> INSPECTION END

NO >> Replace cooling fan relay.



# ELECTRICAL LOAD SIGNAL

< DTC/CIRCUIT DIAGNOSIS >

[QR25DE]

## ELECTRICAL LOAD SIGNAL

### Description

INFOID:0000000011278179

The electrical load signal (Headlamp switch signal, rear window defogger switch signal, etc.) is transferred via the CAN communication.

### Component Function Check

INFOID:0000000011278180

#### 1. CHECK REAR WINDOW DEFOGGER SWITCH FUNCTION

1. Turn ignition switch ON.
2. Connect CONSULT and select "DATA MONITOR" mode.
3. Select "LOAD SIGNAL" and check indication under the following conditions.

Monitor item	Condition	Indication	
LOAD SIGNAL	Rear window defogger switch	ON	ON
		OFF	OFF

Is the inspection result normal?

YES >> GO TO 2.

NO >> Proceed to [EC-465, "Diagnosis Procedure"](#).

#### 2. CHECK LIGHTING SWITCH FUNCTION

Check "LOAD SIGNAL" indication under the following conditions.

Monitor item	Condition	Indication	
LOAD SIGNAL	Lighting switch	ON at 2nd position	ON
		OFF	OFF

Is the inspection result normal?

YES >> GO TO 3.

NO >> Proceed to [EC-465, "Diagnosis Procedure"](#).

#### 3. CHECK HEATER FAN CONTROL SWITCH FUNCTION

Select "HEATER FAN SW" and check indication under the following conditions.

Monitor item	Condition	Indication	
HEATER FAN SW	Heater fan control switch	ON	ON
		OFF	OFF

Is the inspection result normal?

YES >> INSPECTION END

NO >> Proceed to [EC-465, "Diagnosis Procedure"](#).

### Diagnosis Procedure

INFOID:0000000011278181

#### 1. INSPECTION START

Confirm the malfunctioning circuit (rear window defogger, headlamp or heater fan). Refer to [EC-465, "Component Function Check"](#).

Which circuit is related to the incident?

Rear window defogger >> GO TO 2.

Headlamp >> GO TO 3.

Heater fan >> GO TO 4.

#### 2. CHECK REAR WINDOW DEFOGGER SYSTEM

Check rear window defogger system. Refer to [DEF-21, "Work Flow"](#).

## ELECTRICAL LOAD SIGNAL

< DTC/CIRCUIT DIAGNOSIS >

[QR25DE]

---

>> INSPECTION END

### 3.CHECK HEADLAMP SYSTEM

---

Check headlamp system. Refer to [EXL-81, "Work Flow"](#) (with halogen headlamp) or [EXL-218, "Work Flow"](#) (with LED headlamp).

>> INSPECTION END

### 4.CHECK HEATER FAN CONTROL SYSTEM

---

Check heater fan control system. Refer to [HAC-46, "Work Flow"](#) (with automatic air conditioner) or [HAC-147, "Work Flow"](#) (with manual air conditioner).

>> INSPECTION END

# FUEL INJECTOR

< DTC/CIRCUIT DIAGNOSIS >

[QR25DE]

## FUEL INJECTOR

### Component Function Check

INFOID:000000011278182

#### 1.INSPECTION START

Turn ignition switch to START.

Are any cylinders ignited?

- YES >> GO TO 2.
- NO >> Proceed to [EC-467, "Diagnosis Procedure"](#).

#### 2.CHECK FUEL INJECTOR FUNCTION

##### Ⓜ With CONSULT

1. Start engine.
2. Perform "POWER BALANCE" in "ACTIVE TEST" mode with CONSULT.
3. Check that each circuit produces a momentary engine speed drop.

##### ⓧ Without CONSULT

1. Start engine.
2. Listen to each fuel injector operating sound.

**Clicking sound should be heard.**

Is the inspection result normal?

- YES >> INSPECTION END
- NO >> Proceed to [EC-467, "Diagnosis Procedure"](#).

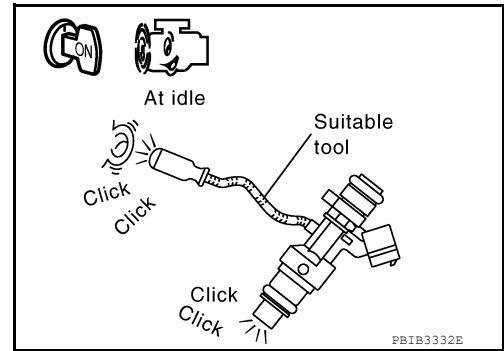

### Diagnosis Procedure

INFOID:000000011278183

#### 1.CHECK FUEL INJECTOR POWER SUPPLY

1. Turn ignition switch OFF.
2. Disconnect fuel injector harness connector.
3. Turn ignition switch ON.
4. Check the voltage between fuel injector harness connector and ground.

+			-	Voltage
Fuel injector				
Cylinder	Connector	Terminal	Ground	Battery voltage
1	F11	1		
2	F12	1		
3	F14	1		
4	F13	1		

Is the inspection result normal?

- YES >> GO TO 3.
- NO >> GO TO 2.

#### 2.CHECK FUEL INJECTOR POWER SUPPLY CIRCUIT

1. Turn ignition switch OFF.
2. Disconnect IPDM E/R harness connector.
3. Check the continuity between fuel injector harness connector and IPDM E/R harness connector.

# FUEL INJECTOR

[QR25DE]

< DTC/CIRCUIT DIAGNOSIS >

+			-		Continuity
Fuel injector			IPDM E/R		
Cylinder	Connector	Terminal	Connector	Terminal	
1	F11	1	E121	43	Existed
2	F12	1			
3	F14	1			
4	F13	1			

Is the inspection result normal?

- YES >> Perform the trouble diagnosis for power supply circuit.  
NO >> Repair or replace error-detected parts.

## 3.CHECK FUEL INJECTOR OUTPUT SIGNAL CIRCUIT

1. Turn ignition switch OFF.
2. Disconnect ECM harness connector.
3. Check the continuity between fuel injector harness connector and ECM harness connector.

+			-		Continuity
Fuel injector			ECM		
Cylinder	Connector	Terminal	Connector	Terminal	
1	F11	2	F51	13	Existed
2	F12	2		14	
3	F14	2		10	
4	F13	2		9	

4. Also check harness for short to ground and to power.

Is the inspection result normal?

- YES >> GO TO 4.  
NO >> Repair open circuit, short to ground or short to power in harness or connectors.

## 4.CHECK FUEL INJECTOR

Check fuel injector. Refer to [EC-468, "Component Inspection"](#).

Is the inspection result normal?

- YES >> GO TO 5.  
NO >> Replace malfunctioning fuel injector. Refer to [EM-45, "Exploded View"](#).

## 5.CHECK INTERMITTENT INCIDENT

Check intermittent incident. Refer to [GI-44, "Intermittent Incident"](#).

Is the inspection result normal?

- YES >> Replace IPDM E/R. Refer to [PCS-40, "Removal and Installation"](#).  
NO >> Repair or replace error-detected parts.

## Component Inspection

INFOID:000000011278184

## 1.CHECK FUEL INJECTOR

1. Turn ignition switch OFF.
2. Disconnect fuel injector harness connector.

# FUEL INJECTOR

[QR25DE]

## < DTC/CIRCUIT DIAGNOSIS >

3. Check resistance between fuel injector terminals as per the following.

Fuel injector		Resistance
+	-	
Terminal		
1	2	11.1 - 14.5 Ω [at 10 - 60°C (50 - 140°F)]

Is the inspection result normal?

YES >> INSPECTION END

NO >> Replace malfunctioning fuel injector. Refer to [EM-45](#), "[Removal and Installation](#)".

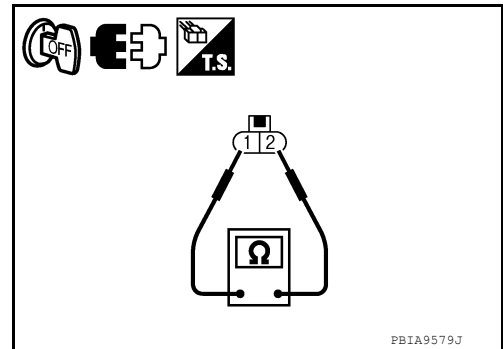

A

EC

C

D

E

F

G

H

I

J

K

L

M

N

O

P

# FUEL PUMP

< DTC/CIRCUIT DIAGNOSIS >

[QR25DE]

## FUEL PUMP

### Description

INFOID:000000011278185

Sensor	Input signal to ECM	ECM Function	Actuator
Crankshaft position sensor (POS) Camshaft position sensor (PHASE)	Engine speed*	Fuel pump control	Fuel pump relay ↓
Battery	Battery voltage*		Fuel pump

\*: ECM determines the start signal status by the signals of engine speed and battery voltage.

The ECM activates the fuel pump for several seconds after the ignition switch is turned ON to improve engine start ability. If the ECM receives a engine speed signal from the camshaft position sensor (PHASE), it knows that the engine is rotating, and causes the pump to operate. If the engine speed signal is not received when the ignition switch is ON, the engine stalls. The ECM stops pump operation and prevents battery discharging, thereby improving safety. The ECM does not directly drive the fuel pump. It controls the ON/OFF fuel pump relay, which in turn controls the fuel pump.

Condition	Fuel pump operation
Ignition switch is turned to ON.	Operates for 1 second.
Engine running and cranking	Operates.
When engine is stopped	Stops in 1.5 seconds.
Except as shown above	Stops.

### Component Function Check

INFOID:000000011278186

#### 1. CHECK FUEL PUMP FUNCTION

1. Turn ignition switch ON.
2. Pinch fuel feed hose with two fingers.

**Fuel pressure pulsation should be felt on the fuel feed hose for 1 second after ignition switch is turned ON.**

Is the inspection result normal?

- YES >> INSPECTION END  
NO >> Proceed to [EC-470, "Diagnosis Procedure"](#).

### Diagnosis Procedure

INFOID:000000011278187

#### 1. CHECK FUEL PUMP RELAY CONTROL SIGNAL

1. Turn ignition switch ON.
2. Check the voltage between ECM harness connector.

ECM				Voltage
+		-		
Connector	Terminal	Connector	Terminal	
F51	18	E16	128	Battery voltage should exist 1 second after ignition switch is turn ON.

Is the inspection result normal?

- YES >> GO TO 3.  
NO >> GO TO 2.

#### 2. CHECK FUEL PUMP RELAY CONTROL SIGNAL CIRCUIT

1. Turn ignition switch OFF.
2. Disconnect ECM harness connector.
3. Disconnect IPDM E/R harness connector.

# FUEL PUMP

[QR25DE]

## < DTC/CIRCUIT DIAGNOSIS >

4. Check the continuity between ECM harness connector and IPDM E/R harness connector.

+		-		Continuity
ECM		IPDM E/R		
Connector	Terminal	Connector	Terminal	
F51	18	F35	76	Existed

5. Also check harness for short to ground and to power.

Is the inspection result normal?

YES >> GO TO 7.

NO >> Repair or replace error-detected parts.

### 3. CHECK FUEL PUMP POWER SUPPLY

1. Turn ignition switch OFF.
2. Disconnect "fuel level sensor unit and fuel pump" harness connector.
3. Turn ignition switch ON.
4. Check the voltage between "fuel level sensor unit and fuel pump" harness connector and ground.

+		-	Voltage
Fuel level sensor unit and fuel pump			
Connector	Terminal		
B103	6	Ground	Battery voltage should exist 1 second after ignition switch is turn ON.

Is the inspection result normal?

YES >> GO TO 5.

NO >> GO TO 4.

### 4. CHECK FUEL PUMP POWER SUPPLY CIRCUIT

1. Turn ignition switch OFF.
2. Disconnect IPDM E/R harness connector.
3. Check the continuity between IPDM E/R harness connector and "fuel level sensor unit and fuel pump" harness connector.

+		-		Continuity
IPDM E/R		Fuel level sensor unit and fuel pump		
Connector	Terminal	Connector	Terminal	
E121	46	B103	6	Existed

4. Also check harness for short to ground and to power.

Is the inspection result normal?

YES >> GO TO 7.

NO >> Repair or replace error-detected parts.

### 5. CHECK FUEL PUMP GROUND CIRCUIT

1. Check the continuity between "fuel level sensor unit and fuel pump" and ground.

+		-	Continuity
Fuel level sensor unit and fuel pump			
Connector	Terminal		
B103	4	Ground	Existed

2. Also check harness for short to power.

Is the inspection result normal?

# FUEL PUMP

[QR25DE]

## < DTC/CIRCUIT DIAGNOSIS >

- YES >> GO TO 6.  
NO >> Repair or replace error-detected parts.

### 6.CHECK FUEL PUMP

Refer to [EC-472. "Component Inspection"](#).

Is the inspection result normal?

- YES >> GO TO 7.  
NO >> Replace "fuel level sensor unit and fuel pump". Refer to [FL-5. "Removal and Installation"](#).

### 7.CHECK INTERMITTENT INCIDENT

Perform [GI-44. "Intermittent Incident"](#).

Is the inspection result normal?

- YES >> Replace IPDM E/R. Refer to [PCS-40. "Removal and Installation"](#).  
NO >> Repair or replace harness or connectors.

## Component Inspection

INFOID:0000000011278188

### 1.CHECK FUEL PUMP

1. Turn ignition switch OFF.
2. Disconnect "fuel level sensor unit and fuel pump" harness connector.
3. Check resistance between "fuel level sensor unit and fuel pump" terminals as follows.

Fuel level sensor unit and fuel pump		Resistance
+	-	
Terminal		
6	4	0.2 - 5.0Ω [at 25°C (77°F)]

Is the inspection result normal?

- YES >> INSPECTION END  
NO >> Replace "fuel level sensor unit and fuel pump". Refer to [FL-5. "Removal and Installation"](#).



# IGNITION SIGNAL

< DTC/CIRCUIT DIAGNOSIS >

[QR25DE]

## IGNITION SIGNAL

### Component Function Check

INFOID:0000000011278189

#### 1.INSPECTION START

Turn ignition switch OFF, and restart engine.

Does the engine start?

- YES-1 >> With CONSULT: GO TO 2.
- YES-2 >> Without CONSULT: GO TO 3.
- NO >> Proceed to [EC-473, "Diagnosis Procedure"](#).

#### 2.CHECK IGNITION SIGNAL FUNCTION

With CONSULT

1. Perform "POWER BALANCE" in "ACTIVE TEST" mode with CONSULT.
2. Check that each circuit produces a momentary engine speed drop.

Is the inspection result normal?

- YES >> INSPECTION END
- NO >> Proceed to [EC-473, "Diagnosis Procedure"](#).

#### 3.CHECK IGNITION SIGNAL FUNCTION

Without CONSULT

1. Let engine idle.
2. Read the voltage signal between ECM harness connector terminals with an oscilloscope.

ECM				Voltage signal
+		-		
Connector	Terminal	Connector	Terminal	
F52	86	E16	128	
	87			
	90			
	91			

**NOTE:**

The pulse cycle changes depending on rpm at idle.

Is the inspection result normal?

- YES >> INSPECTION END
- NO >> Proceed to [EC-473, "Diagnosis Procedure"](#).

### Diagnosis Procedure

INFOID:0000000011278190

#### 1.CHECK ECM POWER SUPPLY

1. Turn ignition switch OFF, wait at least 10 seconds and then turn it ON.
2. Check the voltage between ECM harness connector terminals.

ECM			Voltage
Connector	+	-	
	Terminal		
E16	121	128	Battery voltage

Is the inspection result normal?

- YES >> GO TO 2.
- NO >> Refer to [EC-168, "Diagnosis Procedure"](#).

# IGNITION SIGNAL

[QR25DE]

< DTC/CIRCUIT DIAGNOSIS >

## 2. CHECK CONDENSER POWER SUPPLY

1. Turn ignition switch OFF.
2. Disconnect joint connector-F01 harness connector.
3. Turn ignition switch ON.
4. Check the voltage between joint connector-F01 harness connector and ground.

+		-	Voltage
Joint connector-F01			
Connector	Terminal		
F8	1	Ground	Battery voltage

Is the inspection result normal?

YES >> GO TO 4.

NO >> GO TO 3.

## 3. CHECK CONDENSER POWER SUPPLY CIRCUIT

1. Turn ignition switch OFF.
2. Disconnect IPDM E/R harness connector.
3. Check the continuity between IPDM E/R harness connector and joint connector-F01 harness connector.

+		-		Continuity
IPDM E/R		Joint connector-F01		
Connector	Terminal	Connector	Terminal	
F35	66	F8	1	Existed

4. Also check harness for short to ground and to power.

Is the inspection result normal?

YES >> Refer to [EC-168, "Diagnosis Procedure"](#).

NO >> Repair open circuit, short to ground or short to power in harness or connectors.

## 4. CHECK CONDENSER GROUND CIRCUIT

1. Turn ignition switch OFF.
2. Check the continuity between joint connector-F01 harness connector and ground.

+		-	Voltage
Joint connector-F01			
Connector	Terminal		
F8	6	Ground	Existed

3. Also check harness for short to power.

Is the inspection result normal?

YES >> GO TO 5.

NO >> Repair open circuit or short to power in harness or connectors.

## 5. CHECK CONDENSER

Check condenser. Refer to [EC-477, "Component Inspection \(Condenser\)"](#)

Is the inspection result normal?

YES >> GO TO 6.

NO >> Replace condenser.

## 6. CHECK IGNITION COIL POWER SUPPLY

1. Reconnect all harness connectors disconnected.
2. Disconnect ignition coil harness connector.
3. Turn ignition switch ON.
4. Check the voltage between ignition coil harness connector and ground.

# IGNITION SIGNAL

< DTC/CIRCUIT DIAGNOSIS >

[QR25DE]

+			-	Voltage
Ignition coil				
Cylinder	Connector	Terminal	Ground	Battery voltage
1	F47	3		
2	F46	3		
3	F48	3		
4	F49	3		

Is the inspection result normal?

YES >> GO TO 7.

NO >> Repair or replace harness or connectors.

## 7. CHECK IGNITION COIL GROUND CIRCUIT

1. Turn ignition switch OFF.
2. Check the continuity between ignition coil harness connector and ground.

+			-	Continuity
Ignition coil				
Cylinder	Connector	Terminal	Ground	Existed
1	F47	2		
2	F46	2		
3	F48	2		
4	F49	2		

3. Also check harness for short to power.

Is the inspection result normal?

YES >> GO TO 8.

NO >> Repair open circuit or short to power in harness or connectors.

## 8. CHECK IGNITION COIL OUTPUT SIGNAL CIRCUIT

1. Disconnect ECM harness connector.
2. Check the continuity between ignition coil harness connector and ECM harness connector.

+			-		Continuity
Ignition coil			ECM		
Cylinder	Connector	Terminal	Connector	Terminal	Existed
1	F47	1	F52	86	
2	F46	1		87	
3	F48	1		90	
4	F49	1		91	

3. Also check harness for short to ground and to power.

Is the inspection result normal?

YES >> GO TO 9.

NO >> Repair open circuit, short to ground or short to power in harness or connectors.

## 9. CHECK IGNITION COIL WITH POWER TRANSISTOR

Check ignition coil with power transistor. Refer to [EC-476, "Component Inspection \(Ignition Coil with Power Transistor\)"](#).

Is the inspection result normal?

YES >> Check intermittent incident. Refer to [GI-44, "Intermittent Incident"](#).

NO >> Replace malfunctioning ignition coil with power transistor. Refer to [EM-41, "Removal and Installation"](#).

# IGNITION SIGNAL

< DTC/CIRCUIT DIAGNOSIS >

[QR25DE]

## Component Inspection (Ignition Coil with Power Transistor)

INFOID:000000011278191

### 1. CHECK IGNITION COIL WITH POWER TRANSISTOR-1

1. Turn ignition switch OFF.
2. Disconnect ignition coil harness connector.
3. Check resistance between ignition coil terminals as per the following.

Ignition coil		Resistance $\Omega$ [at 25°C (77°F)]
+	-	
Terminal No. (Polarity)		
1	2	Except 0 or $\infty$
	3	Except 0
2	3	

Is the inspection result normal?

YES >> GO TO 2.

NO >> Replace malfunctioning ignition coil with power transistor. Refer to [EM-41, "Removal and Installation"](#).

### 2. CHECK IGNITION COIL WITH POWER TRANSISTOR-2

#### CAUTION:

Perform the following procedure in a place with no combustible objects and good ventilation.

1. Turn ignition switch OFF.
2. Reconnect all harness connectors disconnected.
3. Remove fuel pump fuse in IPDM E/R to release fuel pressure.

#### NOTE:

Do not use CONSULT to release fuel pressure, or fuel pressure applies again during the following procedure.

4. Start engine.
5. After engine stalls, crank it 2 or 3 times to release all fuel pressure.
6. Turn ignition switch OFF.
7. Remove all ignition coil harness connectors to avoid the electrical discharge from the ignition coils.
8. Remove ignition coil and spark plug of the cylinder to be checked.
9. Crank engine for 5 seconds or more to remove combustion gas in the cylinder.
10. Connect spark plug and harness connector to ignition coil.
11. Fix ignition coil using a rope etc. with gap of 13 - 17 mm (0.52 - 0.66 in) between the edge of the spark plug and grounded metal portion as shown in the figure.
12. Crank engine for approximately 3 seconds, and check whether spark is generated between the spark plug and the grounded metal portion.

**Spark should be generated.**

#### CAUTION:

- During the operation, always stay 0.5 m (19.7 in) or more away from the spark plug and the ignition coil. Be careful not to get an electrical shock while checking, because the electrical discharge voltage becomes 20 kV or more.
- It might cause to damage the ignition coil if the gap of more than 17 mm (0.66 in) is taken.

#### NOTE:

When the gap is less than 13 mm (0.52 in), the spark might be generated even if the coil is malfunctioning.

Is the inspection result normal?

YES >> INSPECTION END

NO >> Replace malfunctioning ignition coil with power transistor. Refer to [EM-41, "Removal and Installation"](#).

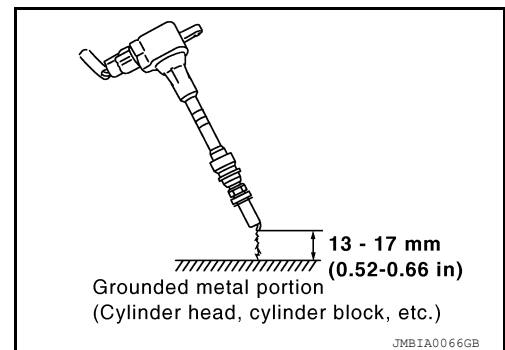

# IGNITION SIGNAL

< DTC/CIRCUIT DIAGNOSIS >

[QR25DE]

## Component Inspection (Condenser)

INFOID:000000011278192

### 1. CHECK CONDENSER

1. Turn ignition switch OFF.
2. Disconnect joint connector-F01 harness connector.
3. Check resistance between joint connector terminals as per the following.

Joint connector-F01		Resistance
+	-	
Terminal		
1	6	Above 1 M $\Omega$ [at 25C° (77C°)]

Is the inspection result normal?

- YES >> INSPECTION END  
NO >> Replace condenser.

A

EC

C

D

E

F

G

H

I

J

K

L

M

N

O

P

## INFORMATION DISPLAY (ASCD)

### Component Function Check

INFOID:000000011278193

#### 1. CHECK INFORMATION DISPLAY

1. Start engine.
2. Press ASCD MAIN switch on ASCD steering switch.
3. Drive the vehicle at more than 40 km/h (25 MPH).  
**CAUTION:**  
**Always drive vehicle at a safe speed.**
4. Press SET/- switch.
5. Check that the reading of the speedometer shows the same value as the set speed indicated in the information display while driving the vehicle on a flat road.

Is the inspection result normal?

- YES >> INSPECTION END  
 NO >> Proceed to [EC-478, "Diagnosis Procedure"](#).

### Diagnosis Procedure

INFOID:000000011278194

#### 1. CHECK DTC

Check that DTC UXXXX, P0500 or P1574 is not displayed.

Is the inspection result normal?

- YES >> GO TO 2.  
 NO-1 >> Perform trouble diagnosis for DTC UXXXX.  
 NO-2 >> Perform trouble diagnosis for DTC P0500. Refer to [EC-353, "DTC Description"](#).  
 NO-3 >> Perform trouble diagnosis for DTC P1574. Refer to [EC-417, "DTC Description"](#).

#### 2. CHECK DTC WITH COMBINATION METER

Refer to [MWI-21, "CONSULT Function \(METER/M&A\)"](#).

Is the inspection result normal?

- YES >> GO TO 3.  
 NO >> Perform trouble diagnosis for DTC indicated.

#### 3. CHECK INTERMITTENT INCIDENT

Perform [GI-44, "Intermittent Incident"](#).

Is the inspection result normal?

- YES >> Replace combination meter. Refer to [MWI-84, "Removal and Installation"](#).  
 NO >> Repair or replace error-detected parts.

# MALFUNCTION INDICATOR LAMP

< DTC/CIRCUIT DIAGNOSIS >

[QR25DE]

## MALFUNCTION INDICATOR LAMP

### Component Function Check

INFOID:0000000011278195

#### 1.CHECK MIL FUNCTION

1. Turn ignition switch ON.
2. Check that MIL illuminates.

Is the inspection result normal?

- YES >> INSPECTION END  
NO >> Proceed to [EC-479, "Diagnosis Procedure"](#).

#### Diagnosis Procedure

INFOID:0000000011278196

#### 1.CHECK DTC

Check that DTC UXXXX is not displayed.

Is the inspection result normal?

- YES >> GO TO 2.  
NO >> Perform trouble diagnosis for DTC UXXXX.

#### 2.CHECK COMBINATION METER FUNCTION

Check combination meter function. Refer to [MWI-21, "CONSULT Function \(METER/M&A\)"](#).

Is the inspection result normal?

- YES >> GO TO 3.  
NO >> Repair or replace.

#### 3.CHECK INTERMITTENT INCIDENT

Check intermittent incident. Refer to [GI-44, "Intermittent Incident"](#).

Is the inspection result normal?

- YES >> Replace combination meter. Refer to [MWI-84, "Removal and Installation"](#).  
NO >> Repair or replace error-detected parts.

A  
EC  
C  
D  
E  
F  
G  
H  
I  
J  
K  
L  
M  
N  
O  
P

# ON BOARD REFUELING VAPOR RECOVERY (ORVR)

< DTC/CIRCUIT DIAGNOSIS >

[QR25DE]

## ON BOARD REFUELING VAPOR RECOVERY (ORVR)

### Component Function Check

INFOID:000000011278197

#### 1.CHECK ORVR FUNCTION

Check whether the following symptoms are present.

- Fuel odor from EVAP canister is strong.
- Cannot refuel/Fuel odor from the fuel filler opening is strong while refueling.

Are any symptoms present?

- YES >> Proceed to [EC-480, "Diagnosis Procedure"](#).  
NO >> INSPECTION END

### Diagnosis Procedure

INFOID:000000011278198

#### 1.INSPECTION START

Check whether the following symptoms are present.

- A: Fuel odor from EVAP canister is strong.  
B: Cannot refuel/Fuel odor from the fuel filler opening is strong while refueling.

A or B

- A >> GO TO 2.  
B >> GO TO 7.

#### 2.CHECK EVAP CANISTER

1. Remove EVAP canister with EVAP canister vent control valve and EVAP control system pressure sensor attached. Refer to [FL-19, "Removal and Installation"](#).
2. Weigh the EVAP canister with EVAP canister vent control valve and EVAP control system pressure sensor attached.

**The weight should be less than 2.1 kg (4.6 lb).**

Is the inspection result normal?

- YES >> GO TO 3.  
NO >> GO TO 4.

#### 3.CHECK IF EVAP CANISTER IS SATURATED WITH WATER

Check if water will drain from EVAP canister

Does water drain from the EVAP canister?

- YES >> GO TO 4.  
NO >> GO TO 6.

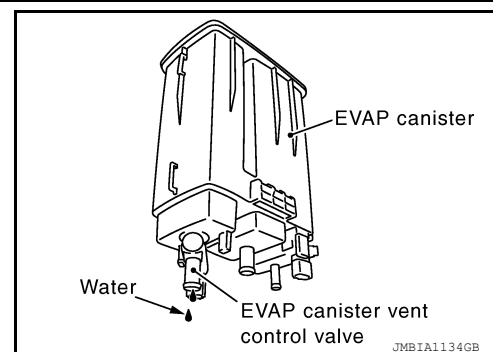

#### 4.REPLACE EVAP CANISTER

Replace EVAP canister with a new one. Refer to [FL-19, "Removal and Installation"](#).

>> GO TO 5.

#### 5.DETECT MALFUNCTIONING PART

Check the EVAP hose between EVAP canister and vehicle frame for clogging or poor connection.

>> Repair or replace EVAP hose. Refer to [FL-11, "FWD : Removal and Installation"](#) (with FWD models) or [FL-15, "AWD : Removal and Installation"](#) (with AWD models).

#### 6.CHECK REFUELING EVAP VAPOR CUT VALVE



# ON BOARD REFUELING VAPOR RECOVERY (ORVR)

[QR25DE]

< DTC/CIRCUIT DIAGNOSIS >

Check refueling EVAP vapor cut valve. Refer to [EC-482, "Component Inspection"](#).

Is the inspection result normal?

YES >> INSPECTION END

NO >> Replace refueling EVAP vapor cut valve with fuel tank. Refer to [FL-11, "FWD : Removal and Installation"](#) (with FWD models) or [FL-15, "AWD : Removal and Installation"](#) (with AWD models).

## 7. CHECK EVAP CANISTER

1. Remove EVAP canister with EVAP canister vent control valve and EVAP control system pressure sensor attached. Refer to [FL-19, "Removal and Installation"](#).

2. Weigh the EVAP canister with EVAP canister vent control valve and EVAP control system pressure sensor attached.

**The weight should be less than 2.1 kg (4.6 lb).**

Is the inspection result normal?

YES >> GO TO 8.

NO >> GO TO 9.

## 8. CHECK IF EVAP CANISTER IS SATURATED WITH WATER

Check if water will drain from EVAP canister.

Does water drain from the EVAP canister?

YES >> GO TO 6.

NO >> GO TO 11.

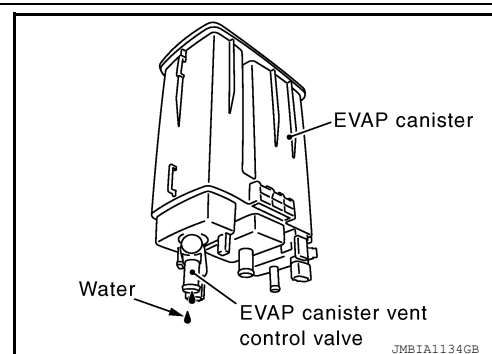

## 9. REPLACE EVAP CANISTER

Replace EVAP canister with a new one. Refer to [FL-19, "Removal and Installation"](#).

>> GO TO 10.

## 10. DETECT MALFUNCTIONING PART

Check the EVAP hose between EVAP canister and vehicle frame for clogging or poor connection.

>> Repair or replace EVAP hose. Refer to [FL-11, "FWD : Removal and Installation"](#) (with FWD models) or [FL-15, "AWD : Removal and Installation"](#) (with AWD models).

## 11. CHECK VENT HOSES AND VENT TUBES

Check hoses and tubes between EVAP canister and refueling control valve for clogging, kinks, looseness and improper connection.

Is the inspection result normal?

YES >> GO TO 12.

NO >> Repair or replace hoses and tubes.

## 12. CHECK FILLER NECK TUBE

Check recirculation line for clogging, dents and cracks.

Is the inspection result normal?

YES >> GO TO 13.

NO >> Replace filler neck tube.

## 13. CHECK REFUELING EVAP VAPOR CUT VALVE

Check refueling EVAP vapor cut valve. Refer to [EC-482, "Component Inspection"](#).

Is the inspection result normal?

YES >> GO TO 14.

# ON BOARD REFUELING VAPOR RECOVERY (ORVR)

[QR25DE]

< DTC/CIRCUIT DIAGNOSIS >

NO >> Replace refueling EVAP vapor cut valve with fuel tank. Refer to [FL-11, "FWD : Removal and Installation"](#) (with FWD models) [FL-15, "AWD : Removal and Installation"](#) (with AWD models).

## 14. CHECK FUEL FILLER TUBE

Check filler neck tube and hose connected to the fuel tank for clogging, dents and cracks.

Is the inspection result normal?

YES >> GO TO 15.

NO >> Replace fuel filler tube. Refer to [FL-11, "FWD : Exploded View"](#) (with FWD models) [FL-15, "AWD : Exploded View"](#) (with AWD models).

## 15. CHECK ONE-WAY FUEL VALVE-1

Check one-way valve for clogging.

Is the inspection result normal?

YES >> GO TO 16.

NO >> Repair or replace one-way fuel valve with fuel tank. Refer to [FL-11, "FWD : Removal and Installation"](#) (with FWD models) [FL-15, "AWD : Removal and Installation"](#) (with AWD models).

## 16. CHECK ONE-WAY FUEL VALVE-2

1. Check that fuel is drained from the tank.
2. Remove fuel filler tube and hose. Refer to [FL-11, "FWD : Exploded View"](#) (with FWD models) [FL-15, "AWD : Exploded View"](#) (with AWD models).
3. Check one-way fuel valve for operation as per the following.  
When a stick is inserted, the valve should open, when removing stick it should close.  
**Do not drop any material into the tank.**

Is the inspection result normal?

YES >> INSPECTION END

NO >> Replace fuel filler tube or replace one-way fuel valve with fuel tank. Refer to [FL-11, "FWD : Removal and Installation"](#) (with FWD models) [FL-15, "AWD : Removal and Installation"](#) (with AWD models).

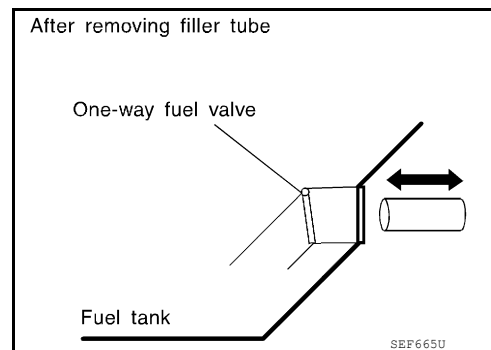

INFOID:000000011278199

## Component Inspection

### 1. INSPECTION START

Will CONSULT be used?

Will CONSULT be used?

YES >> GO TO 2.

NO >> GO TO 3.

### 2. CHECK REFUELING EVAP VAPOR CUT VALVE

#### Ⓟ With CONSULT

1. Turn ignition switch OFF.
2. Remove fuel tank. Refer to [FL-11, "FWD : Removal and Installation"](#) (with FWD models) [FL-15, "AWD : Removal and Installation"](#) (with AWD models).
3. Drain fuel from the tank as per the following:
  - Remove fuel feed hose located on the fuel gauge retainer.
  - Connect a spare fuel hose, one side to fuel gauge retainer where the hose was removed and the other side to a fuel container.
  - Drain fuel using "FUEL PUMP RELAY" in "ACTIVE TEST" mode with CONSULT.
4. Check refueling EVAP vapor cut valve for being stuck to close as per the following.  
Blow air into the refueling EVAP vapor cut valve (from the end of EVAP/ORVR line hose), and check that the air flows freely into the tank.
5. Check refueling EVAP vapor cut valve for being stuck to open as per the following.
  - Connect vacuum pump to hose end.
  - Remove fuel gauge retainer with fuel gauge unit.**Always replace O-ring with new one.**
  - Turn fuel tank upside down.

# ON BOARD REFUELING VAPOR RECOVERY (ORVR)

[QR25DE]

## < DTC/CIRCUIT DIAGNOSIS >

- Apply vacuum pressure to hose end [-13.3 kPa (-0.136 kg/cm<sup>2</sup>, -1.93 psi)] with fuel gauge retainer remaining open and check that the pressure is applicable.

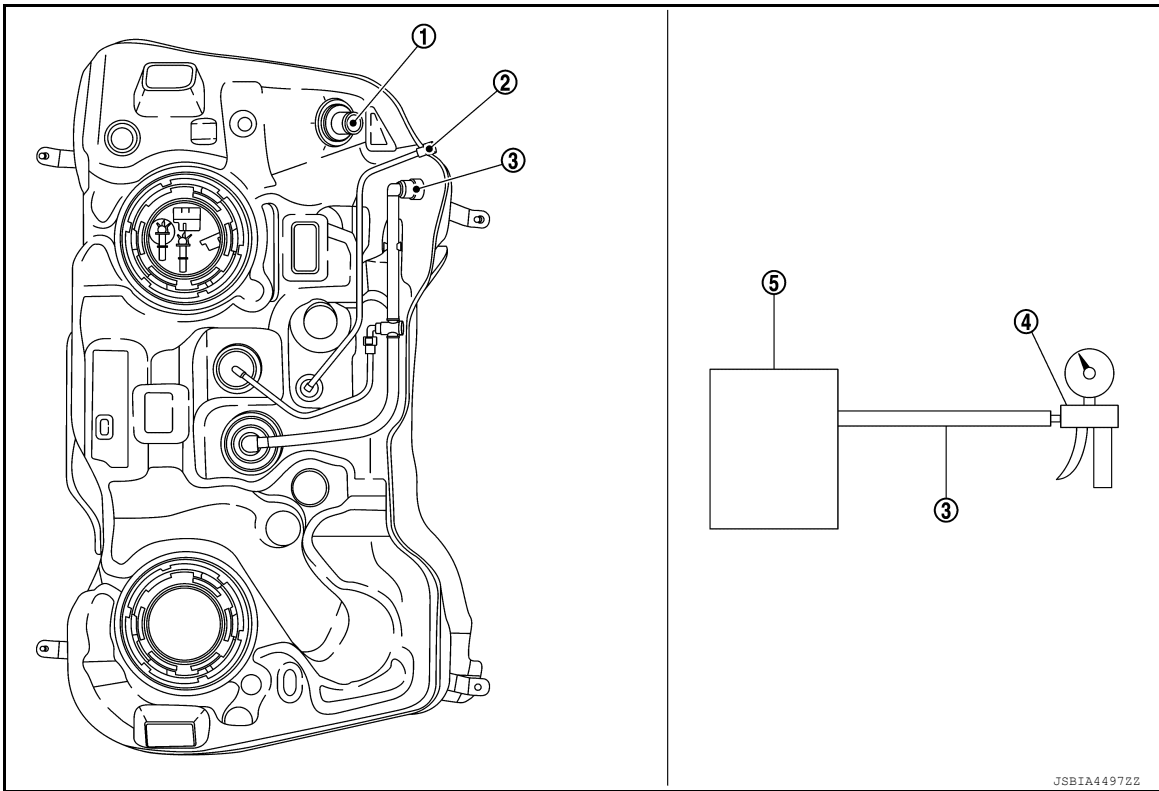

- ① Filler tube
- ② Recirculation line
- ③ EVAP/ORVR line
- ④ Vacuum/pressure handy pump
- ⑤ Fuel tank

### Is the inspection result normal?

YES >> INSPECTION END

NO >> Replace refueling EVAP vapor cut valve with fuel tank. Refer to [FL-11, "FWD : Removal and Installation"](#) (with FWD models) [FL-15, "AWD : Removal and Installation"](#) (with AWD models).

## 3. CHECK REFUELING EVAP VAPOR CUT VALVE

### ⊗ Without CONSULT

1. Turn ignition switch OFF.
2. Remove fuel tank. Refer to [FL-11, "FWD : Removal and Installation"](#) (with FWD models) [FL-15, "AWD : Removal and Installation"](#) (with AWD models).
3. Drain fuel from the tank as per the following:
  - Remove fuel gauge retainer.
  - Drain fuel from the tank using a handy pump into a fuel container.
4. Check refueling EVAP vapor cut valve for being stuck to close as per the following.  
Blow air into the refueling EVAP vapor cut valve (from the end of EVAP/ORVR line hose), and check that the air flows freely into the tank.
5. Check refueling EVAP vapor cut valve for being stuck to open as per the following.
  - Connect vacuum pump to hose end.
  - Remove fuel gauge retainer with fuel gauge unit.

**Always replace O-ring with new one.**

  - Turn fuel tank upside down.
  - Apply vacuum pressure to hose end [-13.3 kPa (-0.136 kg/cm<sup>2</sup>, -1.93 psi)] with fuel gauge retainer remaining open and check that the pressure is applicable.

# ON BOARD REFUELING VAPOR RECOVERY (ORVR)

< DTC/CIRCUIT DIAGNOSIS >

[QR25DE]

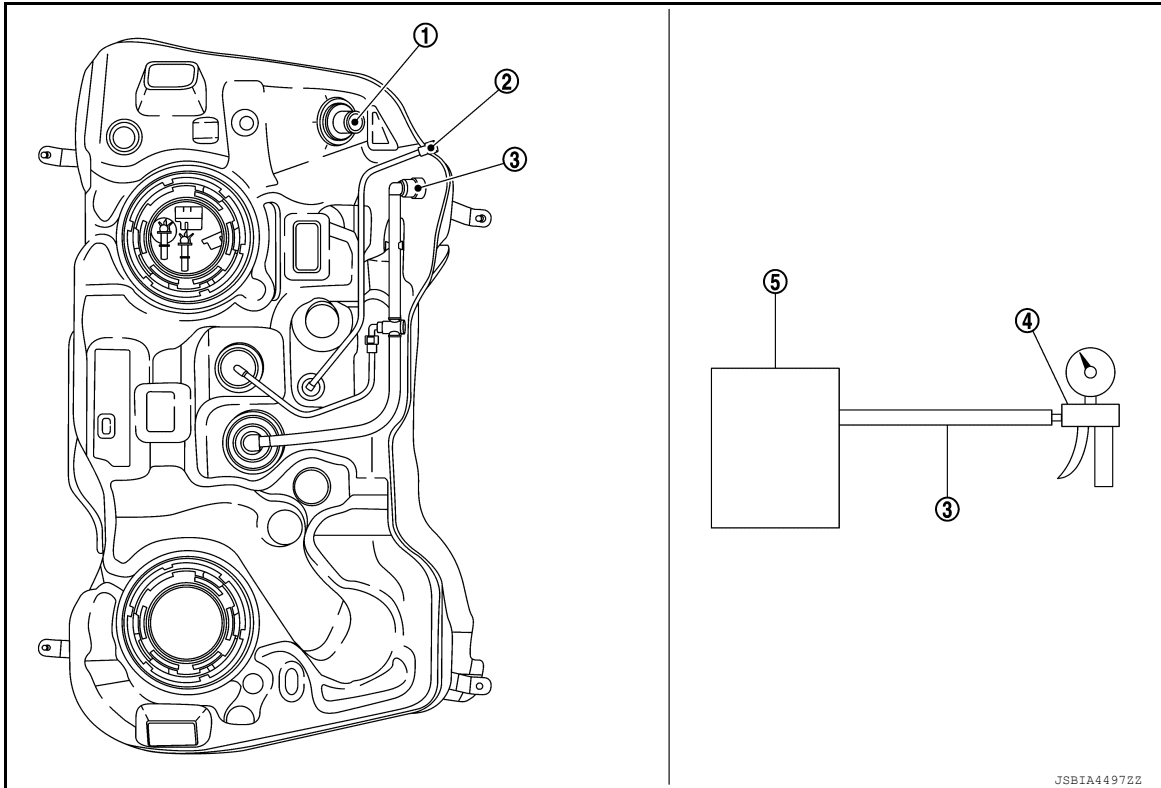

- ① Filler tube
- ② Recirculation line
- ③ EVAP/ORVR line
- ④ Vacuum/pressure handy pump
- ⑤ Fuel tank

**Is the inspection result normal?**

YES >> INSPECTION END

NO >> Replace refueling EVAP vapor cut valve with fuel tank. Refer to [FL-11, "FWD : Removal and Installation"](#) (with FWD models) [FL-15, "AWD : Removal and Installation"](#) (with AWD models).

# REFRIGERANT PRESSURE SENSOR

< DTC/CIRCUIT DIAGNOSIS >

[QR25DE]

## REFRIGERANT PRESSURE SENSOR

### Component Function Check

INFOID:0000000011278200

#### 1. CHECK REFRIGERANT PRESSURE SENSOR FUNCTION

1. Start engine and warm it up to normal operating temperature.
2. Turn A/C switch and blower fan switch ON.
3. Check the voltage between ECM harness connector terminals under the following conditions.

Connector	ECM		Voltage (V)
	+	-	
	Terminal		
E16	103	124	1.0 - 4.0

Is the inspection result normal?

- YES >> INSPECTION END  
NO >> Proceed to [EC-485, "Diagnosis Procedure"](#).

### Diagnosis Procedure

INFOID:0000000011278201

#### 1. CHECK REFRIGERANT PRESSURE SENSOR POWER SUPPLY

1. Disconnect refrigerant pressure sensor harness connector.
2. Turn ignition switch ON.
3. Check the voltage between refrigerant pressure sensor harness connector and ground.

+		-	Voltage (Approx.)
Refrigerant pressure sensor			
Connector	Terminal		
F10	3	Ground	5 V

Is the inspection result normal?

- YES >> GO TO 3.  
NO >> GO TO 2.

#### 2. CHECK REFRIGERANT PRESSURE SENSOR POWER SUPPLY CIRCUIT

1. Turn ignition switch OFF.
2. Disconnect ECM harness connector.
3. Check the continuity between refrigerant pressure sensor harness connector and ECM harness connector.

+		-		Continuity
Refrigerant pressure sensor		ECM		
Connector	Terminal	Connector	Terminal	
F10	3	E16	104	Existed

Is the inspection result normal?

- YES >> Perform the trouble diagnosis for power supply circuit.  
NO >> Repair or replace error-detected parts.

#### 3. CHECK REFRIGERANT PRESSURE SENSOR GROUND CIRCUIT

1. Turn ignition switch OFF.
2. Disconnect ECM harness connector.
3. Check the continuity between refrigerant pressure sensor harness connector and ECM harness connector.

# REFRIGERANT PRESSURE SENSOR

[QR25DE]

< DTC/CIRCUIT DIAGNOSIS >

+		-		Continuity
Refrigerant pressure sensor		ECM		
Connector	Terminal	Connector	Terminal	
F10	1	E16	124	Existed

4. Also check harness for short to power.

Is the inspection result normal?

YES >> GO TO 4.

NO >> Repair or replace error-detected parts.

## 4.CHECK REFRIGERANT PRESSURE SENSOR INPUT SIGNAL CIRCUIT

1. Check the continuity between refrigerant pressure sensor harness connector and ECM harness connector.

+		-		Continuity
Refrigerant pressure sensor		ECM		
Connector	Terminal	Connector	Terminal	
F10	2	E16	103	Existed

2. Also check harness for short to ground and to power.

Is the inspection result normal?

YES >> GO TO 5.

NO >> Repair or replace error-detected parts.

## 5.CHECK INTERMITTENT INCIDENT

Check intermittent incident. Refer to [GI-44, "Intermittent Incident"](#).

Is the inspection result normal?

YES >> Replace refrigerant pressure sensor. Refer to [HAC-108, "Removal and Installation"](#) (with automatic air conditioner) or [HAC-184, "Removal and Installation"](#) (with manual air conditioner).

NO >> Repair or replace error-detected parts.

# SENSOR POWER SUPPLY2 CIRCUIT

< DTC/CIRCUIT DIAGNOSIS >

[QR25DE]

## SENSOR POWER SUPPLY2 CIRCUIT

### Description

INFOID:000000011278202

ECM supplies a voltage of 5 V to some of the sensors systematically divided into 2 groups, respectively. Accordingly, when a short circuit develops in a sensor power source, a malfunction may occur simultaneously in the sensors belonging to the same group as the short-circuited sensor.

Sensor power supply 1

- APP sensor 1
- CKP sensor (POS)
- Intake manifold runner control valve position sensor
- Refrigerant pressure sensor
- TP sensor

#### NOTE:

If sensor power supply 1 circuit is malfunctioning, DTC P0643 is displayed.

Sensor power supply 2

- APP sensor 2
- CMP sensor (PHASE)
- EVT control position sensor
- EOP sensor
- MAF sensor

### Diagnosis Procedure

INFOID:000000011278203

#### 1.CHECK APP SENSOR 2 POWER SUPPLY CIRCUIT-1

1. Turn ignition switch OFF.
2. Disconnect accelerator pedal position (APP) sensor harness connector.
3. Turn ignition switch ON.
4. Check the voltage between APP sensor harness connector and ground.

+		-	Voltage (Approx.)
APP sensor			
Connector	Terminal		
E25	5	Ground	5V

Is the inspection result normal?

- YES >> INSPECTION END  
NO >> GO TO 2.

#### 2.CHECK APP SENSOR 2 POWER SUPPLY CIRCUIT-2

1. Turn ignition switch OFF.
2. Disconnect ECM harness connector.
3. Check the continuity between APP sensor harness connector and ECM harness connector.

+		+		Continuity
APP sensor		ECM		
Connector	Terminal	Connector	Terminal	
E25	5	E16	118	Existed

Is the inspection result normal?

- YES >> GO TO 3.  
NO >> Repair open circuit.

#### 3.CHECK SENSOR POWER SUPPLY 2 CIRCUIT

1. Disconnect following sensors harness connector.
2. Check harness for short to power and short to ground, between the following terminals.

# SENSOR POWER SUPPLY2 CIRCUIT

< DTC/CIRCUIT DIAGNOSIS >

[QR25DE]

ECM		Sensor		
Connector	Terminal	Name	Connector	Terminal
F51	32	CMP sensor (PHASE)	F44	1
	36	MAF sensor	F22	1
	40	EOP sensor	F54	3
	44	EVT control position sensor	F45	1
E16	118	APP sensor 2	E25	5

Is the inspection result normal?

YES >> GO TO 4.

NO >> Repair short to ground or short to power in harness or connectors.

## 4. CHECK COMPONENTS

Check the following.

- APP sensor 2 (Refer to [EC-447. "Component Inspection".](#))
- Camshaft position sensor (PHASE) (Refer to [EC-303. "Component Inspection \(Camshaft position sensor\)".](#))
- EVT control position sensor (Refer to [EC-390. "Component Inspection".](#))
- EOP sensor (Refer to [EC-363. "Component Inspection".](#))
- MAF sensor (Refer to [EC-203. "Component Inspection".](#))

Is the inspection result normal?

YES >> Refer to [GI-44. "Intermittent Incident".](#)

NO >> Replace malfunctioning component.



# ENGINE CONTROL SYSTEM

< SYMPTOM DIAGNOSIS >

[QR25DE]

## SYMPTOM DIAGNOSIS

### ENGINE CONTROL SYSTEM

#### Symptom Table

INFOID:0000000011278204

#### SYSTEM — BASIC ENGINE CONTROL SYSTEM

		SYMPTOM												Reference page	
		HARD/NO START/RESTART (EXCP. HA)	ENGINE STALL	HESITATION/SURGING/FLAT SPOT	SPARK KNOCK/DETONATION	LACK OF POWER/POOR ACCELERATION	HIGH IDLE/LOW IDLE	ROUGH IDLE/HUNTING	IDLING VIBRATION	SLOW/NO RETURN TO IDLE	OVERHEATS/WATER TEMPERATURE HIGH	EXCESSIVE FUEL CONSUMPTION	EXCESSIVE OIL CONSUMPTION		BATTERY DEAD (UNDER CHARGE)
Warranty symptom code		AA	AB	AC	AD	AE	AF	AG	AH	AJ	AK	AL	AM	HA	
Fuel	Fuel pump circuit	1	1	2	3	2		2	2			3		2	<a href="#">EC-470</a>
	Fuel pressure regulator system	3	3	4	4	4	4	4	4	4		4			<a href="#">EC-147</a>
	Fuel injector circuit	1	1	2	3	2		2	2			2			<a href="#">EC-467</a>
	Fuel level sensor circuit														<a href="#">EC-347</a> , <a href="#">EC-350</a>
	Fuel tank temperature sensor circuit														<a href="#">EC-275</a> , <a href="#">EC-277</a>
	Evaporative emission system	3	3	4	4	4	4	4	4	4	4		4		<a href="#">EC-498</a>
Air	Positive crankcase ventilation system	3	3	4	4	4	4	4	4	4		4	1	<a href="#">EC-501</a>	
	Incorrect idle speed adjustment					1	1	1	1		1			<a href="#">EC-144</a>	
	Electric throttle control actuator	1	1	2	3	3	2	2	2	2		2		2	<a href="#">EC-436</a> , <a href="#">EC-441</a>
Ignition	Incorrect ignition timing adjustment	3	3	1	1	1		1	1			1			<a href="#">EC-497</a>
	Ignition circuit	1	1	2	2	2		2	2			2			<a href="#">EC-473</a>
Main power supply and ground circuit		2	2	3	3	3		3	3		2	3			<a href="#">EC-168</a>

# ENGINE CONTROL SYSTEM

< SYMPTOM DIAGNOSIS >

[QR25DE]

	SYMPTOM												Reference page	
	HARD/NO START/RESTART (EXCP. HA)	ENGINE STALL	HESITATION/SURGING/FLAT SPOT	SPARK KNOCK/DETONATION	LACK OF POWER/POOR ACCELERATION	HIGH IDLE/LOW IDLE	ROUGH IDLE/HUNTING	IDLING VIBRATION	SLOW/NO RETURN TO IDLE	OVERHEATS/WATER TEMPERATURE HIGH	EXCESSIVE FUEL CONSUMPTION	EXCESSIVE OIL CONSUMPTION		BATTERY DEAD (UNDER CHARGE)
Warranty symptom code	AA	AB	AC	AD	AE	AF	AG	AH	AJ	AK	AL	AM	HA	
Mass air flow sensor circuit	1			2										<a href="#">EC-201</a> , <a href="#">EC-205</a>
Intake air temperature sensor circuit														<a href="#">EC-210</a> , <a href="#">EC-211</a>
Engine coolant temperature sensor circuit							3			3				<a href="#">EC-216</a> , <a href="#">EC-222</a>
Air fuel ratio (A/F) sensor 1 circuit		1	2	3	2		2	2			2			<a href="#">EC-229</a> , <a href="#">EC-233</a> , <a href="#">EC-236</a> , <a href="#">EC-258</a> , <a href="#">EC-429</a>
Throttle position sensor circuit						2			2					<a href="#">EC-219</a> , <a href="#">EC-287</a> , <a href="#">EC-403</a> , <a href="#">EC-404</a> , <a href="#">EC-449</a>
Accelerator pedal position sensor circuit			3	2	1									<a href="#">EC-443</a> , <a href="#">EC-446</a> , <a href="#">EC-452</a>
Heated oxygen sensor 2 circuit			6		6		6	6			5			<a href="#">EC-239</a> , <a href="#">EC-247</a> , <a href="#">EC-254</a>
Knock sensor circuit			2								3			<a href="#">EC-296</a>
Engine oil temperature sensor circuit			4		2						3			<a href="#">EC-282</a> , <a href="#">EC-284</a>
Engine oil pressure sensor circuit			4		4	3	3	3			3			<a href="#">EC-361</a> , <a href="#">EC-365</a>
Crankshaft position sensor (POS) circuit	2	2												<a href="#">EC-298</a>
Camshaft position sensor (PHASE) circuit	3	2												<a href="#">EC-301</a>
Vehicle speed signal circuit		2	3		3						3			<a href="#">EC-353</a>
ECM	2	2	3	3	3	3	3	3	3	3	3			<a href="#">EC-373</a> , <a href="#">EC-375</a> , <a href="#">EC-376</a> , <a href="#">EC-379</a> , <a href="#">EC-380</a> , <a href="#">EC-381</a>
Intake valve timing control solenoid valve circuit		3	2		1	3	2	2	3		3			<a href="#">EC-180</a> , <a href="#">EC-194</a>

# ENGINE CONTROL SYSTEM

< SYMPTOM DIAGNOSIS >

[QR25DE]

	SYMPTOM												Reference page	
	HARD/NO START/RESTART (EXCP. HA)	ENGINE STALL	HESITATION/SURGING/FLAT SPOT	SPARK KNOCK/DETONATION	LACK OF POWER/POOR ACCELERATION	HIGH IDLE/LOW IDLE	ROUGH IDLE/HUNTING	IDLING VIBRATION	SLOW/NO RETURN TO IDLE	OVERHEATS/WATER TEMPERATURE HIGH	EXCESSIVE FUEL CONSUMPTION	EXCESSIVE OIL CONSUMPTION		BATTERY DEAD (UNDER CHARGE)
Warranty symptom code	AA	AB	AC	AD	AE	AF	AG	AH	AJ	AK	AL	AM	HA	
Intake valve timing intermediate lock control solenoid valve circuit														<a href="#">EC-367</a>
Exhaust valve timing control solenoid valve circuit		3	2		1	3	2	2	3		3			<a href="#">EC-198</a>
PNP signal circuit			3		3		3	3			3			<a href="#">EC-385</a>
Refrigerant pressure sensor circuit		2				3			3		4			<a href="#">EC-485</a>
Electrical load signal circuit							3							<a href="#">EC-465</a>
Intake manifold runner control valve motor circuit					4	4								<a href="#">EC-423</a>
Intake manifold runner control valve position sensor circuit					4	4								<a href="#">EC-426</a>
Air conditioner circuit	2	2	3	3	3	3	3	3	3		3		2	<a href="#">HAC-46</a> , <a href="#">HAC-147</a>
ASCD steering switch circuit														<a href="#">EC-406</a>
ABS actuator and electric unit (control unit)			4											<a href="#">BRC-64</a>

1 - 6: The numbers refer to the order of inspection.  
(continued on next table)

## SYSTEM — ENGINE MECHANICAL & OTHER

A  
**EC**  
 C  
 D  
 E  
 F  
 G  
 H  
 I  
 J  
 K  
 L  
 M  
 N  
 O  
 P

# ENGINE CONTROL SYSTEM

< SYMPTOM DIAGNOSIS >

[QR25DE]

		SYMPTOM													Reference page															
		HARD/NO START/RESTART (EXCP. HA)	ENGINE STALL	HESITATION/SURGING/FLAT SPOT	SPARK KNOCK/DETONATION	LACK OF POWER/POOR ACCELERATION	HIGH IDLE/LOW IDLE	ROUGH IDLE/HUNTING	IDLING VIBRATION	SLOW/NO RETURN TO IDLE	OVERHEATSWATER TEMPERATURE HIGH	EXCESSIVE FUEL CONSUMPTION	EXCESSIVE OIL CONSUMPTION	BATTERY DEAD (UNDER CHARGE)																
Warranty symptom code		A A	AB	AC	AD	AE	AF	AG	AH	AJ	AK	AL	AM	HA																
Fuel	Fuel tank	5	5												<a href="#">FL-11, FL-15</a>															
	Fuel piping			5	5	5		5	5			5			<a href="#">EM-45</a>															
	Vapor lock	5														—														
	Valve deposit																—													
	Poor fuel (Heavy weight gasoline, Low octane)			5	5	5	5		5	5			5				—													
Air	Air duct	5	5	5	5	5	5	5	5	5	5	5	5	5	5	<a href="#">EM-26</a>														
	Air cleaner																													
	Air leakage from air duct (Mass air flow sensor — electric throttle control actuator)																													
	Electric throttle control actuator																													
	Air leakage from intake manifold/Collector/Gasket																													
Cranking	Battery	1	1	1		1		1	1						1	<a href="#">PG-78</a>														
	Generator circuit															<a href="#">CHG-5</a>														
	Starter circuit	3										1				<a href="#">STR-6</a>														
	Signal plate	6														<a href="#">EM-98</a>														
	PNP signal	4														<a href="#">TM-220</a>														
Engine	Cylinder head	5	5	5	5	5	5	5	5	5	5	5	5	5	5	<a href="#">EM-66</a>														
	Cylinder head gasket																4	3												
	Cylinder block																													
	Piston																4													
	Piston ring																													
	Connecting rod	6															6	6	6	6	6	6	6	6	6	6	6	6	6	<a href="#">EM-98</a>
	Bearing																													
	Crankshaft																													

# ENGINE CONTROL SYSTEM

< SYMPTOM DIAGNOSIS >

[QR25DE]

		SYMPTOM												Reference page	
		HARD/NO START/RESTART (EXCP. HA)	ENGINE STALL	HESITATION/SURGING/FLAT SPOT	SPARK KNOCK/DETONATION	LACK OF POWER/POOR ACCELERATION	HIGH IDLE/LOW IDLE	ROUGH IDLE/HUNTING	IDLING VIBRATION	SLOW/NO RETURN TO IDLE	OVERHEATS/WATER TEMPERATURE HIGH	EXCESSIVE FUEL CONSUMPTION	EXCESSIVE OIL CONSUMPTION		BATTERY DEAD (UNDER CHARGE)
Warranty symptom code		A A	AB	AC	AD	AE	AF	AG	AH	AJ	AK	AL	AM	HA	
Valve mechanism	Timing chain													<a href="#">EM-50</a>	
	Camshaft													<a href="#">EM-69</a>	
	Intake valve timing control	5	5	5	5	5		5	5			5		<a href="#">EM-50</a>	
	Intake valve												3		<a href="#">EM-66</a>
	Exhaust valve														
Exhaust	Exhaust manifold/Tube/Muffler/Gasket	5	5	5	5	5		5	5			5		<a href="#">EM-32, EX-5</a>	
	Three way catalyst														
Lubrication	Oil pan/Oil strainer/Oil pump/Oil filter/Oil gallery/Oil cooler	5	5	5	5	5		5	5			5		<a href="#">EM-36, LU-7, LU-10, LU-5, LU-13</a>	
	Oil level (Low)/Filthy oil													<a href="#">LU-7</a>	
Cooling	Radiator/Hose/Radiator filler cap													<a href="#">CO-13</a>	
	Thermostat									5				<a href="#">CO-21</a>	
	Water pump									5				<a href="#">CO-19</a>	
	Water gallery	5	5	5	5	5		5	5		4	5		<a href="#">CO-5</a>	
	Cooling fan									5				<a href="#">CO-17</a>	
	Coolant level (Low)/Contaminated coolant									5				<a href="#">CO-8</a>	
NVIS (NISSAN Vehicle Immobilizer System — NATS)		1	1											<a href="#">SEC-63, SEC-156</a>	

1 - 6: The numbers refer to the order of inspection.

A  
EC  
C  
D  
E  
F  
G  
H  
I  
J  
K  
L  
M  
N  
O  
P

# INFORMATION DISPLAY IS MALFUNCTIONING

< SYMPTOM DIAGNOSIS >

[QR25DE]

---

## INFORMATION DISPLAY IS MALFUNCTIONING

### Diagnosis Procedure

INFOID:000000011278205

#### 1.CHECK DTC WITH ECM

---

Check that DTC is not displayed.

Is the inspection result normal?

YES >> GO TO 2.

NO >> Perform trouble diagnosis relevant to DTC indicated.

#### 2.CHECK INFORMATION DISPLAY (ASCD)

---

Refer to [EC-478. "Component Function Check"](#).

Is the inspection result normal?

YES >> GO TO 3.

NO >> Repair or replace malfunctioning part.

#### 3.CHECK INTERMITTENT INCIDENT

---

Refer to [GI-44. "Intermittent Incident"](#).

>> INSPECTION END

# NORMAL OPERATING CONDITION

< SYMPTOM DIAGNOSIS >

[QR25DE]

## NORMAL OPERATING CONDITION

### Description

INFOID:000000011278206

#### FUEL CUT CONTROL (AT NO LOAD AND HIGH ENGINE SPEED)

If the engine speed is above 1,800 rpm under no load (for example, the selector lever position is neutral and engine speed is over 1,800 rpm) fuel will be cut off after some time. The exact time when the fuel is cut off varies based on engine speed.

Fuel cut will be operated until the engine speed reaches 1,500 rpm, then fuel cut will be cancelled.

**NOTE:**

This function is different from deceleration control listed under Multiport Fuel Injection (MFI) System, [EC-37](#), "[MULTIPOINT FUEL INJECTION SYSTEM : System Description \(with automatic air conditioner\)](#)" or [EC-39](#), "[MULTIPOINT FUEL INJECTION SYSTEM : System Description \(with manual air conditioner\)](#)".

A  
EC  
C  
D  
E  
F  
G  
H  
I  
J  
K  
L  
M  
N  
O  
P

---

# PERIODIC MAINTENANCE

## IDLE SPEED

### Inspection

INFOID:0000000011278207

#### 1. CHECK IDLE SPEED

---

④ With CONSULT

Check idle speed in "DATA MONITOR" mode of "ENGINE" using CONSULT.

④ With GST

Check idle speed with Service \$01 of GST.

>> INSPECTION END



## IGNITION TIMING

### Inspection

INFOID:000000011278208

### 1. CHECK IGNITION TIMING

1. Attach timing light (A) to the ignition coil No.1 harness①.

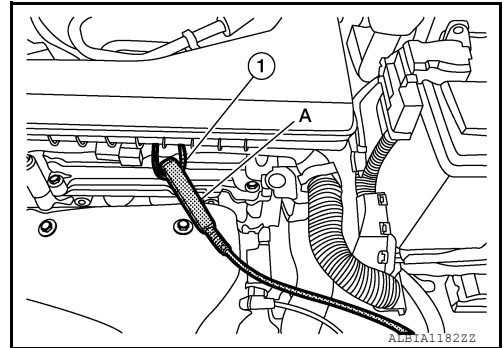

2. Check ignition timing.

① : Timing indicator

>> INSPECTION END

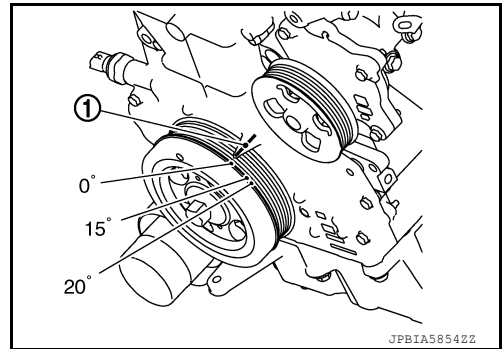

A  
EC  
C  
D  
E  
F  
G  
H  
I  
J  
K  
L  
M  
N  
O  
P

# EVAPORATIVE EMISSION SYSTEM

< PERIODIC MAINTENANCE >

[QR25DE]

## EVAPORATIVE EMISSION SYSTEM

### Inspection

INFOID:000000011278209

#### EVAP CANISTER

##### 1. CHECK EVAP CANISTER

1. Block port (B).
2. Blow air into port (A) and check that it flows freely out of port (C).
3. Release blocked port (B).
4. Apply vacuum pressure to port (B) and check that vacuum pressure exists at the ports (A) and (C).
5. Block port (A) and (B).
6. Apply pressure to port (C) and check that there is no leakage.

>> INSPECTION END

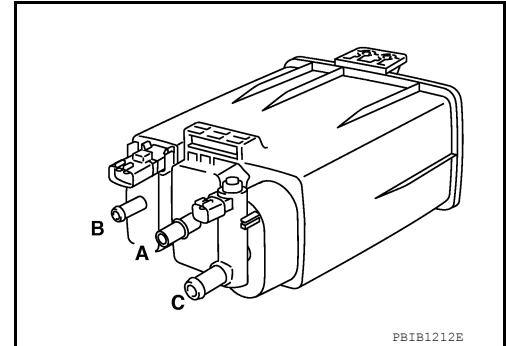

# EVAP LEAK CHECK

< PERIODIC MAINTENANCE >

[QR25DE]

## EVAP LEAK CHECK

### Inspection

INFOID:0000000011278210

#### CAUTION:

- Do not use compressed air or a high pressure pump.
- Do not exceed 4.12 kPa (0.042 kg/cm<sup>2</sup>, 0.6 psi) of pressure in EVAP system.

#### NOTE:

- Do not start engine.
- Improper installation of EVAP service port adapter [commercial service tool: (J-41413-OBD)] to the EVAP service port may cause a leak.

### 1. EVAP LEAK CHECK

#### ☐ With CONSULT

1. Install EVAP service port adapter [commercial service tool: (J-41413-OBD)] and pressure pump to EVAP service port.

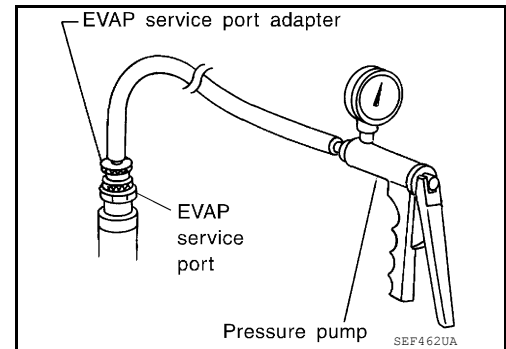

2. Turn ignition switch ON.
3. Select the "EVAP SYSTEM CLOSE" in "WORK SUPPORT" mode of "ENGINE" using CONSULT.
4. Touch "START". A bar graph (Pressure indicating display) will appear on the screen.
5. Apply positive pressure to the EVAP system until the pressure indicator reaches the middle of the bar graph.
6. Remove EVAP service port adapter [commercial service tool: (J-41413-OBD)] and hose with pressure pump.
7. Locate the leak using a leak detector [commercial service tool: (J-41416)]. Refer to [EC-55, "EVAPORATIVE EMISSION SYSTEM : System Description"](#).

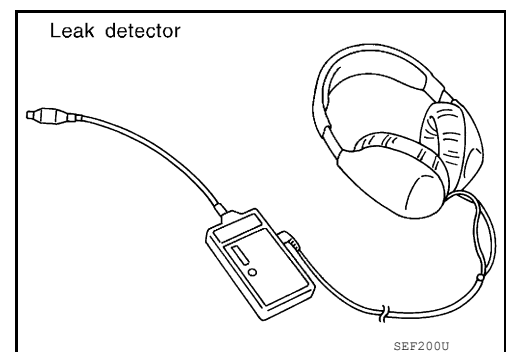

#### ☒ Without CONSULT

1. Install EVAP service port adapter [commercial service tool: (J-41413-OBD)] and pressure pump to EVAP service port.

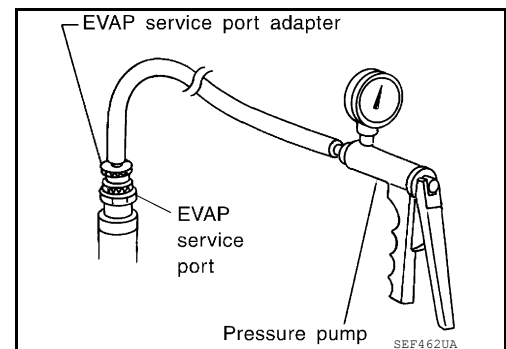

## EVAP LEAK CHECK

[QR25DE]

< PERIODIC MAINTENANCE >

2. Apply battery voltage between the terminals of EVAP canister vent control valve to make a closed EVAP system.
3. To locate the leak, deliver positive pressure to the EVAP system until pressure gauge points reach 1.38 to 2.76 kPa (0.014 to 0.028 kg/cm<sup>2</sup>, 0.2 to 0.4 psi).
4. Remove EVAP service port adapter [commercial service tool: (J-41413-OBD)] and hose with pressure pump.
5. Locate the leak using a leak detector [commercial service tool: (J-41416)]. Refer to [EC-55. "EVAPORATIVE EMISSION SYSTEM : System Description"](#).

>> INSPECTION END

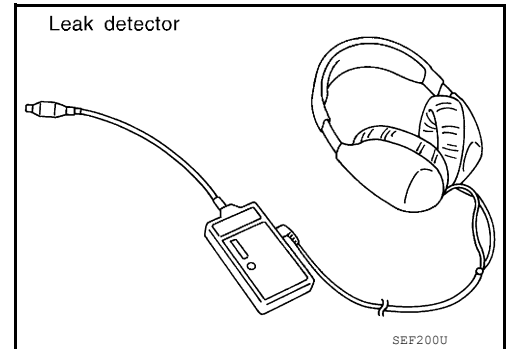

# POSITIVE CRANKCASE VENTILATION

< PERIODIC MAINTENANCE >

[QR25DE]

## POSITIVE CRANKCASE VENTILATION

### Inspection

INFOID:000000011278211

#### 1. CHECK PCV VALVE

With engine running at idle, remove PCV valve from rocker cover. A properly working valve makes a hissing noise as air passes through it. A strong vacuum should be felt immediately when a finger is placed over valve inlet.

Is the inspection result normal?

YES >> INSPECTION END

NO >> Replace PCV valve. Refer to [EC-14](#),  
["Component Parts Location"](#).

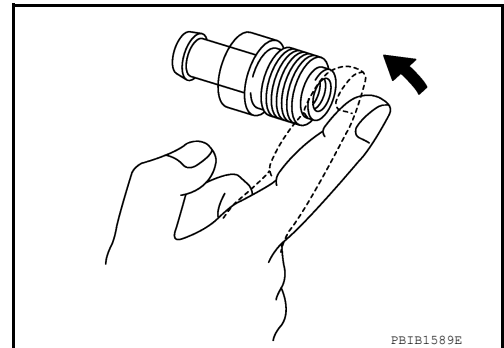

A

EC

C

D

E

F

G

H

I

J

K

L

M

N

O

P

# REMOVAL AND INSTALLATION

## ECM

### Removal and Installation

INFOID:000000011278212

#### EXPLODED VIEW

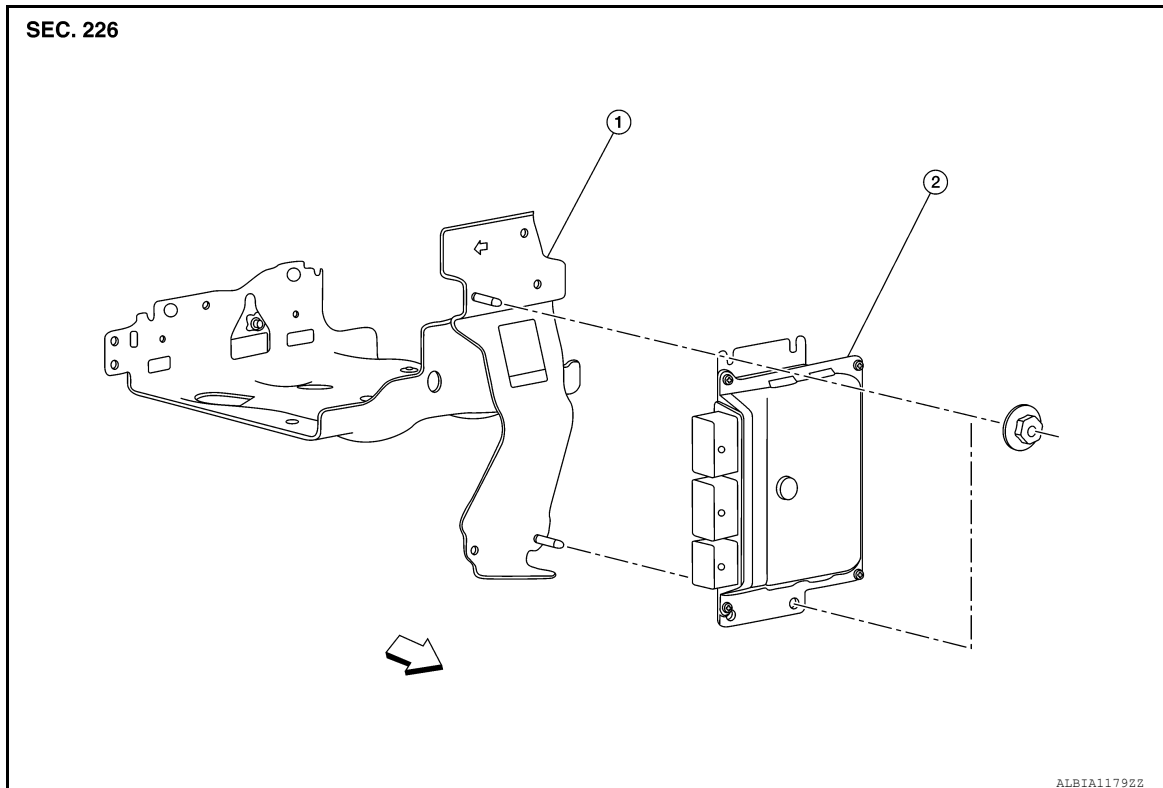

① ECM bracket  
 ⇐ : Vehicle front

② ECM

#### CAUTION:

Perform **ADDITIONAL SERVICE WHEN REPLACING ECM**. Refer to [EC-139, "Work Procedure"](#).

#### REMOVAL

1. Disconnect the battery negative terminal.
2. Remove the air inlet duct. Refer to [EM-26, "Removal and Installation"](#).
3. Remove the resonator. Refer to [EM-26, "Exploded View"](#).
4. Disconnect ECM harness connectors.
5. Remove ECM mounting nuts, and then remove ECM.

#### INSTALLATION

Install in the reverse order of removal.

# SERVICE DATA AND SPECIFICATIONS (SDS)

< SERVICE DATA AND SPECIFICATIONS (SDS)

[QR25DE]

## SERVICE DATA AND SPECIFICATIONS (SDS)

### SERVICE DATA AND SPECIFICATIONS (SDS)

#### Idle Speed

INFOID:0000000011278213

Condition	Specification
No load* (in P or N position)	650 ± 50 rpm

\*: Under the following conditions

- A/C switch: OFF
- Electric load: OFF (Lights, heater fan & rear window defogger)
- Steering wheel: Kept in straight-ahead position

#### Ignition Timing

INFOID:0000000011278214

Condition	Specification
No load* (in P or N position)	10 ± 2° BTDC

\*: Under the following conditions

- A/C switch: OFF
- Electric load: OFF (Lights, heater fan & rear window defogger)
- Steering wheel: Kept in straight-ahead position

#### Calculated Load Value

INFOID:0000000011278215

Condition	Specification (Using CONSULT or GST)
At idle	10 – 35 %
At 2,500 rpm	10 – 35 %

#### Mass Air Flow Sensor

INFOID:0000000011278216

Supply voltage	Battery voltage (11 – 14 V)
Output voltage at idle	1.3 – 1.6 V*
Mass air flow (Using CONSULT or GST)	1.0 – 4.0 g/s at idle* 4.0 – 10.0 g/s at 2,500 rpm*

\*: Engine is warmed up to normal operating temperature and running under no load.