

SECTION **FSU**
FRONT SUSPENSION

A
B
C
D
F
G
H
I
J
K
L
M
N
O
P

FSU

CONTENTS

PRECAUTION	2	TRANSVERSE LINK	13
PRECAUTIONS	2	Exploded View	13
Precaution for Supplemental Restraint System (SRS) "AIR BAG" and "SEAT BELT PRE-TENSIONER"	2	Removal and Installation	13
Precaution for Procedure without Cowl Top Cover.....	2	FRONT STABILIZER	15
Precautions for Suspension	2	Exploded View	15
PREPARATION	3	Removal and Installation	15
PREPARATION	3	STEERING KNUCKLE	18
Special Service Tool	3	Exploded View	18
Commercial Service Tool	3	Removal and Installation	18
SYMPTOM DIAGNOSIS	5	UNIT REMOVAL AND INSTALLATION	21
NOISE, VIBRATION AND HARSHNESS (NVH) TROUBLESHOOTING	5	FRONT SUSPENSION MEMBER	21
NVH Troubleshooting Chart	5	Exploded View	21
PERIODIC MAINTENANCE	6	Removal and Installation	21
FRONT SUSPENSION ASSEMBLY	6	UNIT DISASSEMBLY AND ASSEMBLY ...	23
Inspection	6	FRONT COIL SPRING AND STRUT	23
WHEEL ALIGNMENT	7	Exploded View	23
Inspection	7	Disassembly and Assembly	23
Adjustment	8	Disposal	25
REMOVAL AND INSTALLATION	10	SERVICE DATA AND SPECIFICATIONS (SDS)	27
FRONT COIL SPRING AND STRUT	10	SERVICE DATA AND SPECIFICATIONS (SDS)	27
Exploded View	10	Wheel Alignment (Unladen* ¹)	27
Removal and Installation	10	Ball Joint	27
		Wheelarch Height (Unladen*)	28

PRECAUTIONS

< PRECAUTION >

PRECAUTION

PRECAUTIONS

Precaution for Supplemental Restraint System (SRS) "AIR BAG" and "SEAT BELT PRE-TENSIONER"

INFOID:000000012427616

The Supplemental Restraint System such as "AIR BAG" and "SEAT BELT PRE-TENSIONER", used along with a front seat belt, helps to reduce the risk or severity of injury to the driver and front passenger for certain types of collision. Information necessary to service the system safely is included in the SR and SB section of this Service Manual.

WARNING:

- To avoid rendering the SRS inoperative, which could increase the risk of personal injury or death in the event of a collision which would result in air bag inflation, all maintenance must be performed by an authorized NISSAN/INFINITI dealer.
- Improper maintenance, including incorrect removal and installation of the SRS, can lead to personal injury caused by unintentional activation of the system. For removal of Spiral Cable and Air Bag Module, see the SR section.
- Do not use electrical test equipment on any circuit related to the SRS unless instructed to in this Service Manual. SRS wiring harnesses can be identified by yellow and/or orange harnesses or harness connectors.

PRECAUTIONS WHEN USING POWER TOOLS (AIR OR ELECTRIC) AND HAMMERS

WARNING:

- When working near the Airbag Diagnosis Sensor Unit or other Airbag System sensors with the Ignition ON or engine running, DO NOT use air or electric power tools or strike near the sensor(s) with a hammer. Heavy vibration could activate the sensor(s) and deploy the air bag(s), possibly causing serious injury.
- When using air or electric power tools or hammers, always switch the Ignition OFF, disconnect the battery and wait at least three minutes before performing any service.

Precaution for Procedure without Cowl Top Cover

INFOID:000000012427617

When performing the procedure after removing cowl top cover, cover the lower end of windshield with urethane, etc to prevent damage to windshield.

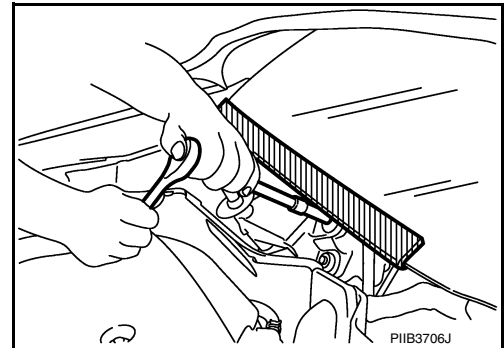

Precautions for Suspension

INFOID:000000012427618

- When installing rubber bushings, the final tightening must be carried out under unladen conditions with tires on ground. Spilled oil might shorten the life of rubber bushings. Be sure to wipe off any spilled oil.
- Unladen conditions mean that fuel, engine coolant and lubricants are full. Spare tire, jack, hand tools and mats are in designated positions.
- After servicing suspension parts, be sure to check wheel alignment.
- Self-lock nuts are not reusable. Always use new ones when installing. Since new self-lock nuts are pre-oiled, tighten as they are.

PREPARATION

< PREPARATION >

PREPARATION

PREPARATION

Special Service Tool

INFOID:0000000012427619

The actual shape of the tools may differ from those illustrated here.

Tool number (TechMate No.) Tool name	Description
ST35652000 (—) Strut attachment	Disassembling and assembling strut
— (J-44372) Pull Gauge	Measuring ball joint swinging force
— (J-49286) Drift and Pull gauge	Measuring drift and pull

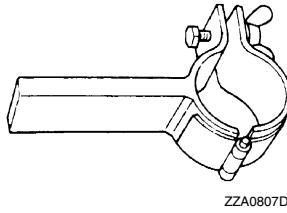

ZZA0807D

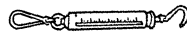

LST024

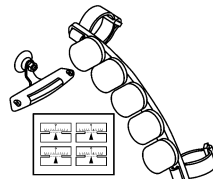

AWEIA0156ZZ

Commercial Service Tool

INFOID:0000000012427620

Tool name	Description
Spring compressor	Removing and installing coil spring

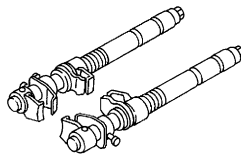

S-NT717

A
B
C
D
FSU
F
G
H
I
J
K
L
M
N
O
P

PREPARATION

< PREPARATION >

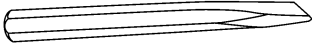
Tool name	Description
<p data-bbox="155 197 261 218">Power tool</p>  <p data-bbox="878 415 948 432">PIIB1407E</p>	<p data-bbox="1052 197 1386 218">Loosening nuts, screws and bolts</p>
<p data-bbox="155 449 220 470">Chisel</p>  <p data-bbox="878 665 964 682">ALEIA0224ZZ</p>	<p data-bbox="1052 449 1468 504">Separating steering knuckle from front coil spring and strut</p>

NOISE, VIBRATION AND HARSHNESS (NVH) TROUBLESHOOTING

< SYMPTOM DIAGNOSIS >

SYMPTOM DIAGNOSIS

NOISE, VIBRATION AND HARSHNESS (NVH) TROUBLESHOOTING

NVH Troubleshooting Chart

INFOID:0000000012427621

Use chart below to find the cause of the symptom. If necessary, repair or replace these parts.

Symptom		Possible cause and SUSPECTED PARTS														Reference			
		Improper installation, looseness	Strut deformation, damage or deflection	Bushing or mounting deterioration	Parts interference	Front coil spring fatigue	Suspension looseness	Incorrect wheel alignment	Stabilizer bar fatigue	PROPELLER SHAFT (AWD)	DIFFERENTIAL (AWD)	FRONT AXLE	TIRE	WHEEL	DRIVE SHAFT		BRAKE	STEERING	
Symptom	FRONT SUSPENSION	Noise	x	x	x	x	x	x			x	x	x	x	x	x	x	FSU-10, FSU-13, FSU-15, FSU-21	
		Shake	x	x	x	x		x			x		x	x	x	x	x	FSU-6	
		Vibration	x	x	x	x	x				x		x	x	x			—	
		Shimmy	x	x	x	x			x				x	x	x		x	x	FSU-6
		Shudder	x	x	x								x	x	x		x	x	FSU-10, FSU-13, FSU-15, FSU-21
		Poor quality ride or handling	x	x	x	x	x		x	x			x	x	x				FSU-7

x: Applicable

A
B
C
D
E
F
G
H
I
J
K
L
M
N
O
P

FSU

FRONT SUSPENSION ASSEMBLY

< PERIODIC MAINTENANCE >

PERIODIC MAINTENANCE

FRONT SUSPENSION ASSEMBLY

Inspection

INFOID:0000000012427622

COMPONENT

Check the conditions (looseness, backlash) of each component. Verify the component conditions (wear, damage) are normal.

Ball Joint Axial End Play

1. Set front wheels in a straight-ahead position.
2. Move axle side of transverse link, and check the axial end play by moving the transverse link up and down.

Axial end play : Refer to [FSU-27, "Ball Joint"](#).

CAUTION:

- Do not depress brake pedal when measuring.
- Do not perform this inspection with the tires on the ground.
- Be careful not to damage ball joint boot. Do not damage components by applying excessive force.

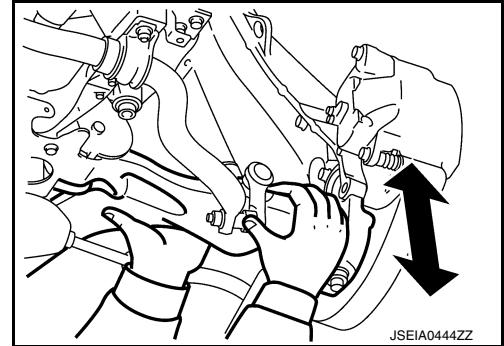

JSEIA0444ZZ

STRUT

Check for oil leakage and damage. Replace if necessary.

WHEEL ALIGNMENT

< PERIODIC MAINTENANCE >

WHEEL ALIGNMENT

Inspection

INFOID:000000012427623

PRELIMINARY INSPECTION

WARNING:

Always adjust the wheel alignment with the vehicle on a flat surface.

NOTE:

If the wheel alignment is out of specification, inspect and replace any damaged or worn rear suspension parts before making any adjustments.

Check the following:

1. Check and adjust the wheel alignment with the vehicle under unladen conditions. "Unladen conditions" means that the fuel, engine coolant, and lubricants are full; the spare tire, jack, hand tools and mats are in designated positions.
2. Check the tires for incorrect air pressure and excessive wear. Refer to [WT-82, "Tire Air Pressure"](#).
3. Check the wheels for run out and damage. Refer to [WT-63, "Inspection"](#).
4. Check the wheel bearing axial end play. Refer to [FAX-7, "Inspection"](#) (FWD), or [FAX-45, "Inspection"](#) (AWD).
5. Check the struts for leaks or damage.
6. Check each mounting point of the suspension components for any excessive looseness or damage.
7. Check each link, arm, and the suspension member for any damage.
8. Check the vehicle height. Refer to [FSU-28, "Wheelarch Height \(Unladen*\)"](#).

GENERAL INFORMATION AND RECOMMENDATIONS

- A four-wheel thrust alignment should be performed.
- This type of alignment is recommended for any NISSAN vehicle.
- The four-wheel "thrust" process helps ensure that the vehicle is properly aligned and the steering wheel is centered.
- The alignment rack itself should be capable of accepting any NISSAN vehicle.
- The rack should be checked to ensure that it is level.
- Make sure the machine is properly calibrated.
- Your alignment equipment should be regularly calibrated in order to give correct information.
- Check with the manufacturer of your specific equipment for their recommended Service/Calibration Schedule.

ALIGNMENT PROCESS

IMPORTANT:

Use only the alignment specifications listed in this Service Manual. Refer to [FSU-27, "Wheel Alignment \(Unladen*¹\)"](#).

- When displaying the alignment settings, many alignment machines use "indicators": (Green/red, plus or minus, Go/No Go). **Do not use these indicators.**
- The alignment specifications programmed into your machine that operate these indicators may not be correct.
- This may result in an ERROR.
- Most camera-type alignment machines are equipped with both "Rolling Compensation" method and optional "Jacking Compensation" method to "compensate" the alignment targets or head units. "Rolling Compensation" is the preferred method.
- If using the "Rolling Compensation" method, after installing the alignment targets or head units, push or pull on the rear wheel to move the vehicle. **Do not push or pull on the vehicle body.**
- If using the "Jacking Compensation" method, after installing the alignment targets or head units, raise the vehicle and rotate the wheels 1/2 turn both ways.

NOTE:

- Do not use the "Rolling Compensation" method if you are using sensor-type alignment equipment.
- Follow all instructions for the alignment machine you're using for more information.

CAMBER, CASTER AND KINGPIN INCLINATION ANGLES INSPECTION

- Camber, caster, kingpin inclination angles cannot be adjusted.
- Before inspection, set the front wheels onto a turning radius gauge. Set the rear wheels onto a pad that has the same height so the vehicle will remain horizontal.

WHEEL ALIGNMENT

< PERIODIC MAINTENANCE >

TOTAL TOE-IN INSPECTION

Measure the total toe-in using the following procedure.

WARNING:

- Always perform the following procedure on a flat surface.
- Make sure that no person is in front of vehicle before pushing it.

1. Bounce the front of vehicle up and down to stabilize the vehicle height (posture).
2. Push on the rear wheel to move the vehicle straight ahead about 5 m (16 ft).
3. Put a mark on base line of the tread (rear side) of both tires at the same height of hub center. These are measuring points.

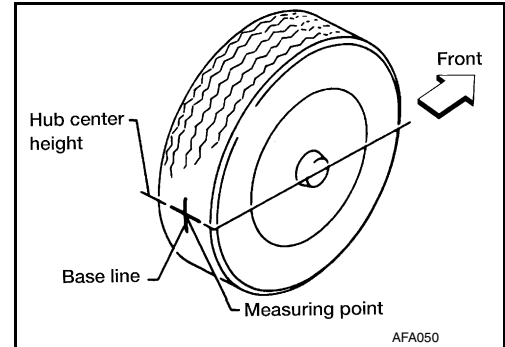

4. Measure the distance (A) from the rear side.
5. Push on the rear wheel to move the vehicle slowly ahead and to rotate the wheels 180 degrees (1/2 turn).

CAUTION:

If the wheels have rotated more than 180 degrees (1/2 turn), try the above procedure again from the beginning. Do not push vehicle backward.

6. Measure the distance (B) from the front side.

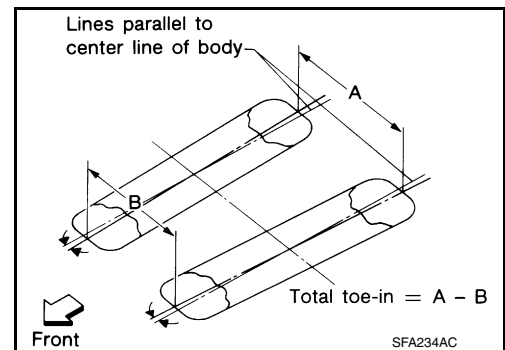

7. Use the formula below to calculate total toe-in.

Total toe-in formula : $A - B$

Total toe-in specification : Refer to [FSU-27, "Wheel Alignment \(Unladen*1\)"](#).

- If the total toe-in is outside the specification, adjust the total toe-in. Refer to [FSU-8, "Adjustment"](#).

Adjustment

INFOID:000000012427624

TOE-IN ADJUSTMENT

1. Loosen the inner socket locknut (A).

CAUTION:

To prevent damage, hold outer socket (1) across flats using suitable tool while loosening inner socket lock nut.

2. Adjust the toe using the inner socket.

CAUTION:

Always evenly adjust toe using LH and RH inner sockets alternately and adjust the total toe-in to the standard.

Total toe-in : Refer to [FSU-27, "Wheel Alignment \(Unladen*1\)"](#).

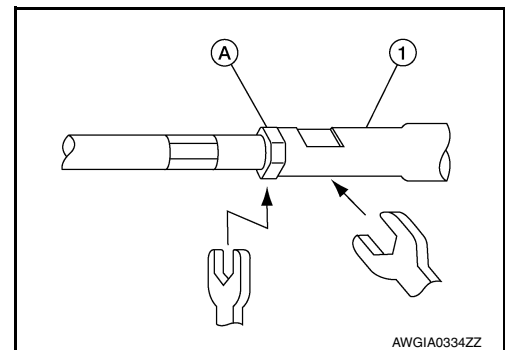

3. Tighten the inner socket locknut. Refer to [ST-23, "Exploded View"](#).

CAUTION:

- To prevent damage, hold outer socket across flats using suitable tool while tightening inner socket lock nut.
- Inspect to make sure no boot deformation has occurred during toe-in adjustment. Adjust boot as necessary.

WHEEL ALIGNMENT

< PERIODIC MAINTENANCE >

4. After toe-in adjustment, adjust neutral position of steering angle sensor. Refer to [BRC-72. "Work Procedure"](#).

A

B

C

D

FSU

F

G

H

I

J

K

L

M

N

O

P

FRONT COIL SPRING AND STRUT

< REMOVAL AND INSTALLATION >

REMOVAL AND INSTALLATION

FRONT COIL SPRING AND STRUT

Exploded View

INFOID:000000012427625

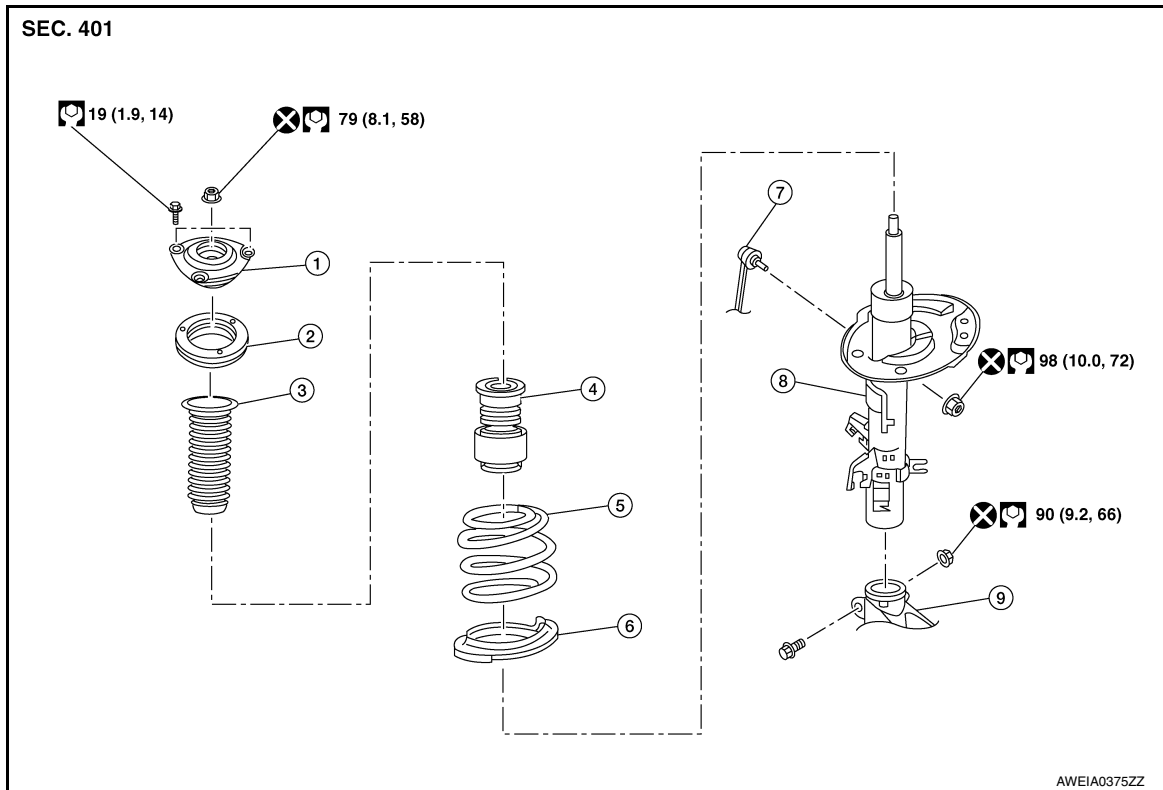

- | | | |
|----------------------------------|------------------------|-----------------------------------|
| 1. Strut mount insulator | 2. Strut mount bearing | 3. Front spring upper rubber seat |
| 4. Front suspension bound bumper | 5. Front coil spring | 6. Front spring lower rubber seat |
| 7. Stabilizer connecting rod | 8. Strut | 9. Steering knuckle |

Removal and Installation

INFOID:000000012427626

REMOVAL

1. Remove the wheel and tire using power tool. Refer to [WT-67, "Removal and Installation"](#).
2. Remove the brake hose lock plate from strut.
3. Remove the bolt (1) and separate the front wheel sensor from the steering knuckle. Refer to [BRC-181, "FRONT WHEEL SENSOR : Exploded View"](#).

CAUTION:

- Failure to separate the front wheel sensor from the steering knuckle may result in damage to the front wheel sensor.
- Pull out the front wheel sensor, being careful to turn it as little as possible. Do not pull on wheel sensor harness.

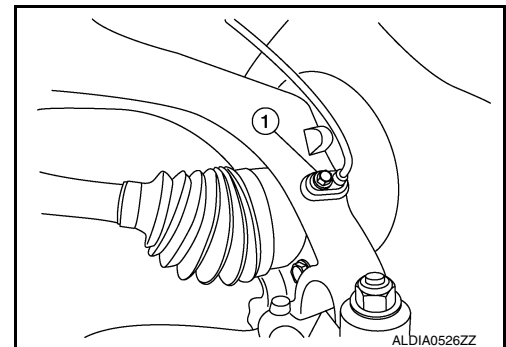

4. Remove brake caliper torque member bolts, leaving the brake hose attached. Position brake caliper aside with wire. Refer to [BR-37, "BRAKE CALIPER ASSEMBLY \(1 PISTON TYPE\) : Exploded View"](#) (1 PISTON TYPE), or [BR-41, "BRAKE CALIPER ASSEMBLY \(2 PISTON TYPE\) : Exploded View"](#) (2 PISTON TYPE).

CAUTION:

FRONT COIL SPRING AND STRUT

< REMOVAL AND INSTALLATION >

Do not depress brake pedal while brake caliper is removed.

- Put alignment marks (A) on the disc brake rotor and on the wheel hub and bearing. Remove the disc brake rotor.

CAUTION:

Do not drop the disc brake rotor.

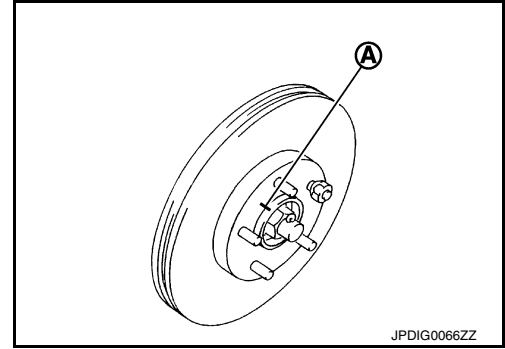

- Remove the cotter pin from the drive shaft.
- Remove the nut retainer from the wheel hub lock nut.
- Loosen the wheel hub lock nut using power tool.
- Using a piece of wood and a suitable tool, tap on the lock nut to disengage the drive shaft from the wheel hub and bearing.

CAUTION:

- Do not place the drive shaft joint at an extreme angle. Be careful not to over extend the slide joint.**
- Do not allow the drive shaft to hang without support.**

NOTE:

Use a suitable puller if drive shaft cannot be separated from the wheel hub and bearing.

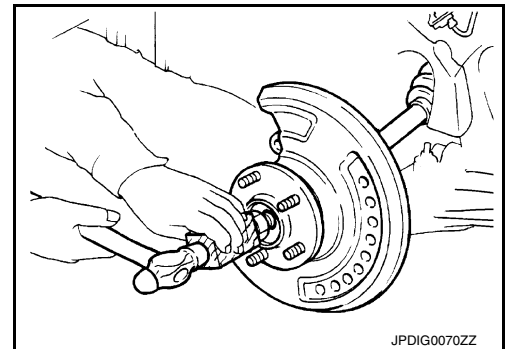

- Remove the wheel hub lock nut. Refer to [FAX-9, "Exploded View"](#) (FWD) or to [FAX-47, "Exploded View"](#) (AWD).
- Separate drive shaft from wheel hub and bearing.
- Remove the nut and separate the stabilizer connecting rod from the strut bracket.
- Remove the nut and separate the outer socket from the steering knuckle. Refer to [ST-21, "Exploded View"](#).
- Remove the upper nut and bolt from steering knuckle. Refer to [FAX-9, "Exploded View"](#).
- Open the slot using a suitable tool (A). Separate the steering knuckle (1) from the front coil spring and strut.

CAUTION:

Do not drop steering knuckle.

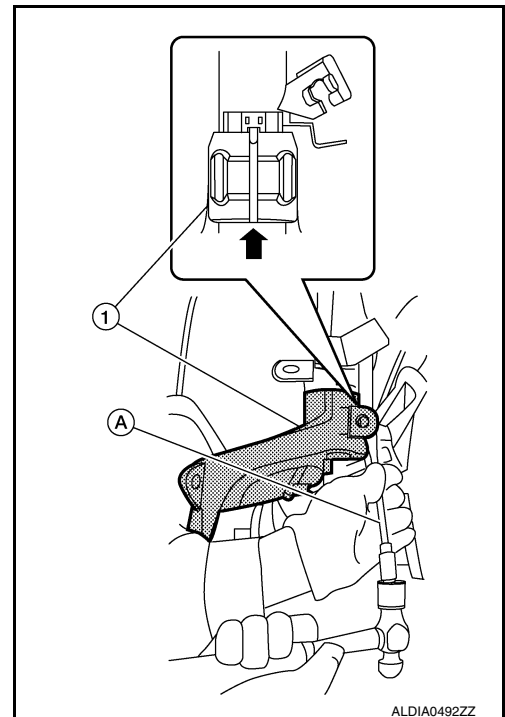

FRONT COIL SPRING AND STRUT

< REMOVAL AND INSTALLATION >

16. Remove the lower nut and bolt from the steering knuckle. Separate transverse link from the steering knuckle. Refer to [FAX-9, "Exploded View"](#).
17. Remove the cowl top cover plug to access the upper strut bolt.
18. Remove the upper strut bolts and the front coil spring and strut.

INSPECTION AFTER REMOVAL

Strut

Check the following items, and replace the parts if necessary.

- Strut for deformation, cracks or damage
- Piston rod for damage, uneven wear or distortion
- Oil leakage

Strut Mounting Insulator and Rubber Parts Inspection

Check strut mounting insulator for cracks and rubber parts for wear. Replace it if necessary.

Coil Spring

Check coil spring for cracks, wear or damage. Replace it if necessary.

INSTALLATION

CAUTION:

- **Do not reuse the wheel hub lock nut.**
- **Do not reuse the cotter pin.**
- **Do not reuse steering knuckle upper bolt nut.**
- **Do not reuse steering knuckle lower nut.**

Installation is in the reverse order of removal.

- Adjust the neutral position of the steering angle sensor. Refer to [BRC-72, "Work Procedure"](#).
- After replacing strut, always follow the disposal procedure to discard the strut. Refer to [FSU-25, "Disposal"](#).

INSPECTION AFTER INSTALLATION

Check wheel alignment. Refer to [FSU-7, "Inspection"](#).

TRANSVERSE LINK

< REMOVAL AND INSTALLATION >

TRANSVERSE LINK

Exploded View

INFOID:000000012427627

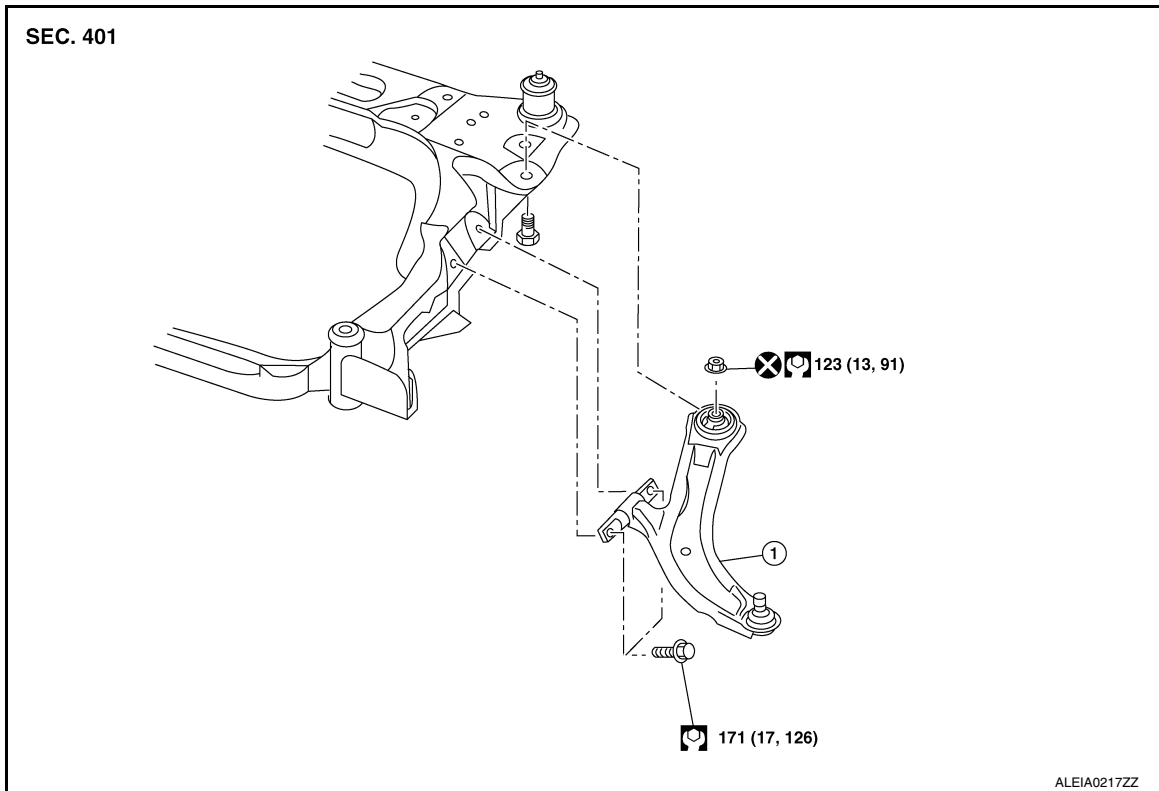

1. Transverse link

Removal and Installation

INFOID:000000012427628

REMOVAL

1. Remove the wheel and tire using power tool. Refer to [WT-67, "Removal and Installation"](#).
2. Remove the engine side cover. Refer to [EXT-29, "FENDER PROTECTOR : Exploded View"](#).
3. Remove the steering knuckle lower bolt and nut. Refer to [FSU-18, "Exploded View"](#)
4. Remove transverse link nuts and bolts from suspension member, and remove transverse link.

CAUTION:

Do not reuse the transverse link nut.

INSPECTION AFTER REMOVAL

Check the following items, and replace the components as necessary.

Ball Joint Inspection

Manually move ball joint to confirm it moves smoothly with no binding.

Transverse Link

- Check the transverse link and bushing for deformation, cracks or damage.
- Check the ball joint boot for cracks or other damage, and also for grease leaks.

Swinging Torque

1. Move the ball joint at least ten times by hand to check for smooth movement with no binding.

TRANSVERSE LINK

< REMOVAL AND INSTALLATION >

- Hook the Tool (A) on the on ball joint (B). Confirm the measurement value is within specifications when the ball joint begins moving.

Tool number : — (J-44372)

Swinging torque : Refer to [FSU-27, "Ball Joint"](#).

- If swinging torque or rotating torque exceeds standard range, replace the transverse link.

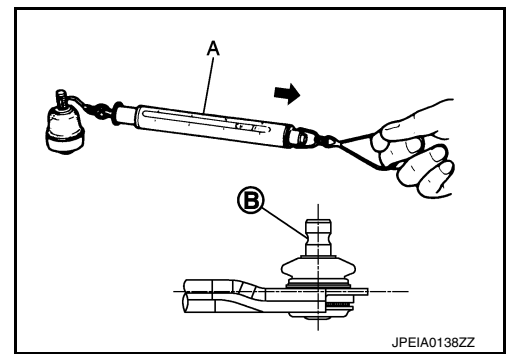

Rotating Torque

- Move the ball joint at least ten times by hand to check for smooth movement.
- Confirm measurement value is within specifications when the ball joint begins rotating.

Rotating torque : Refer to [FSU-27, "Ball Joint"](#).

- If the rotating torque exceeds the standard value, replace the transverse link.

Axial End Play

- Move the ball joint at least ten times by hand to check for smooth movement.
- Move the tip of the ball joint in the axial direction to check for looseness.

Axial end play : Refer to [FSU-27, "Ball Joint"](#).

- If the axial end play exceeds the standard value, replace the transverse link.

INSTALLATION

Installation is in the reverse order of removal.

- Perform final tightening of nuts and bolts under unladen conditions with tires on level ground.

CAUTION:

Do not reuse the transverse link nut.

INSPECTION AFTER INSTALLATION

- Adjust neutral position of the steering angle sensor. Refer to [BRC-72, "Work Procedure"](#).
- Check the wheel alignment. Refer to [FSU-7, "Inspection"](#).

FRONT STABILIZER

< REMOVAL AND INSTALLATION >

FRONT STABILIZER

Exploded View

INFOID:000000012427629

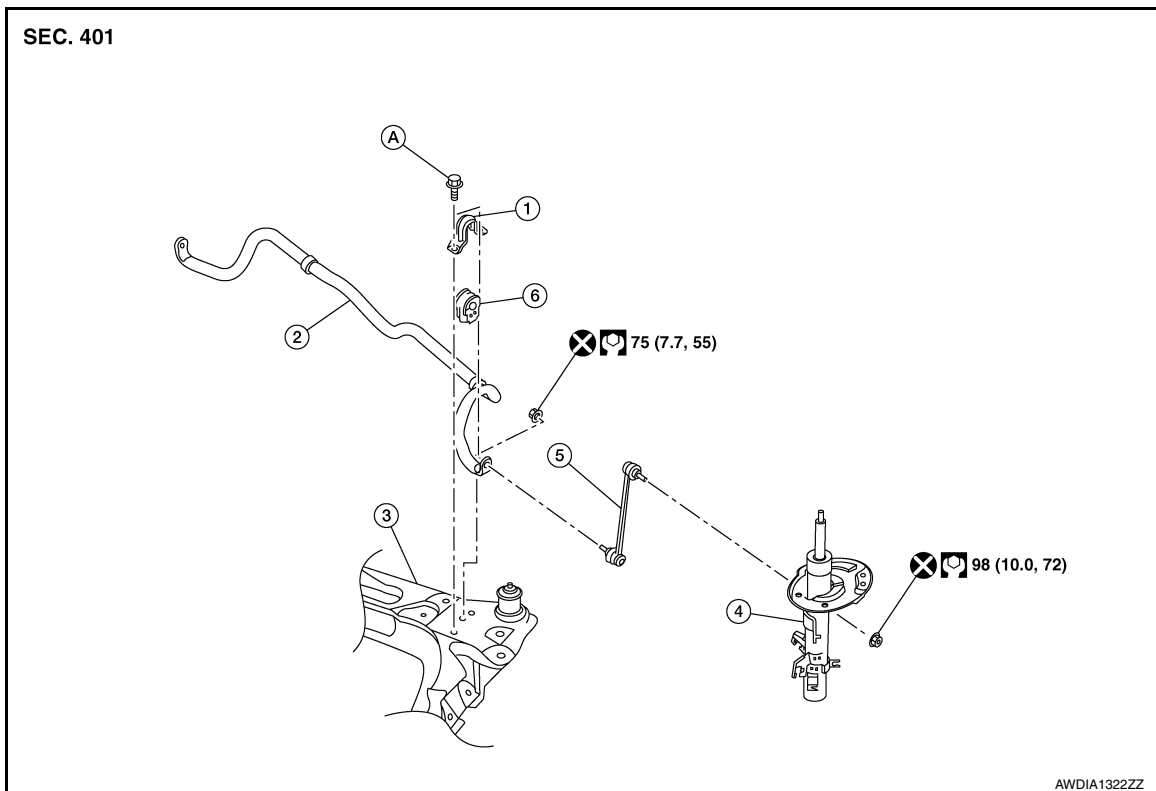

- | | | |
|--------------------------|------------------------------|----------------------------|
| 1. Stabilizer clamp | 2. Stabilizer bar | 3. Front suspension member |
| 4. Strut | 5. Stabilizer connecting rod | 6. Stabilizer bushing |
| A. Refer to Installation | | |

Removal and Installation

INFOID:000000012427630

REMOVAL

1. Remove the column hole cover. Refer to [ST-12, "Exploded View"](#).
2. Remove bolt and separate steering column from steering gear pinion shaft. Refer to [ST-12, "Exploded View"](#).
CAUTION:
With the steering linkage disconnected, the spiral cable may snap by turning the steering wheel beyond the limited number of turns. Secure the steering wheel during removal of the stabilizer bar.
3. Remove the wheel and tire using power tool. Refer to [WT-67, "Removal and Installation"](#).
4. Remove the engine side cover. Refer to [EXT-29, "FENDER PROTECTOR : Exploded View"](#).
5. Set suitable jack under front suspension member.
6. Remove the stabilizer connecting rod nuts and remove the stabilizer connecting rod (LH/RH). Refer to [FSU-15, "Exploded View"](#).
7. Remove the outer socket nut and separate the outer socket from the steering knuckle (LH/RH). Refer to [ST-21, "Exploded View"](#).
8. Remove front exhaust mount. Refer to [EX-5, "Exploded View"](#).
9. Remove catalytic converter. Refer to [EX-5, "Exploded View"](#).
10. Remove rear torque rod. Refer to [EM-86, "Exploded View"](#).
11. Remove bolts, front suspension member stay, and rebound stopper.

FRONT STABILIZER

< REMOVAL AND INSTALLATION >

12. Gradually lower the jack and the rear of the front suspension member in order to remove stabilizer clamp bolts.

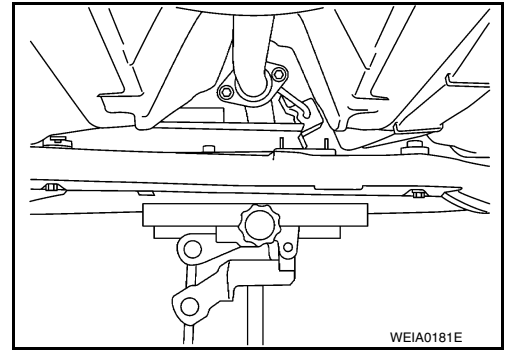

13. Remove stabilizer clamp bolts (←), and then remove stabilizer clamp and stabilizer bushing from front suspension member.

14. Remove stabilizer bar.

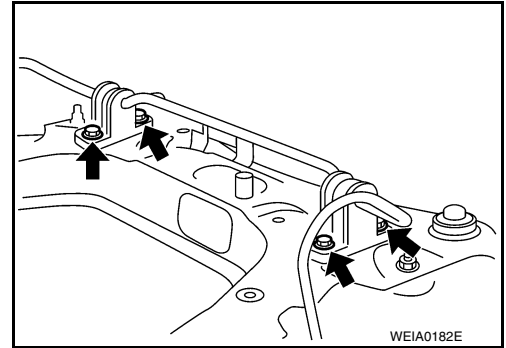

INSPECTION AFTER REMOVAL

Check the stabilizer bar, the stabilizer connecting rod, the stabilizer bushing and the stabilizer clamp for deformation, cracks or damage. Replace components if necessary.

INSTALLATION

Installation is in the reverse order of removal.

CAUTION:

- With the steering linkage disconnected, the spiral cable may snap by turning the steering wheel beyond the limited number of turns. Secure the steering wheel during installation of the stabilizer bar.
- When connecting the steering column (1) to the steering gear pinion shaft (2), be sure that the gap (A) lines up with the joint retaining bolt hole.
- Make sure the bolt is in the correct direction, as shown, and is securely seated in the groove.

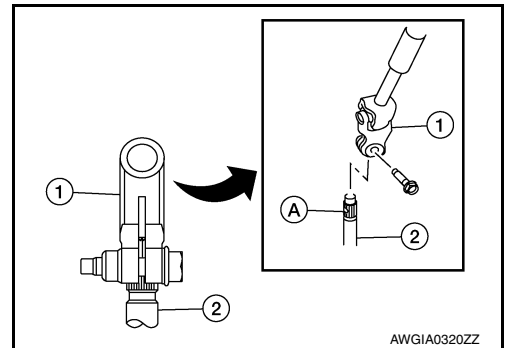

1. Install stabilizer clamp so that notch (A) is facing front of vehicle (←).
2. Install stabilizer bushing so that slit (B) is facing front of vehicle (←).

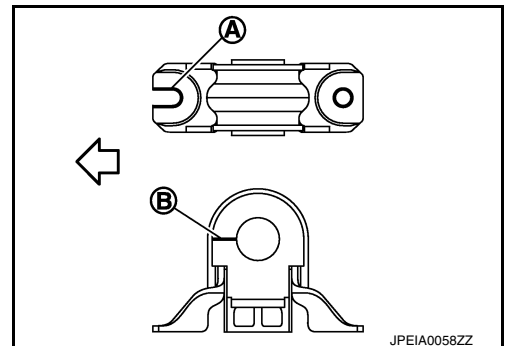

FRONT STABILIZER

< REMOVAL AND INSTALLATION >

3. Install the stabilizer clamp bolts in the order of 1 to 5 as shown.

Manual tightening : 1
Temporary tightening : 2 → 3
Final tightening (Specified torque) : 4 → 5

Specified torque : 33 N·m (3.4 kg·m, 24 ft·lb)

← : Front

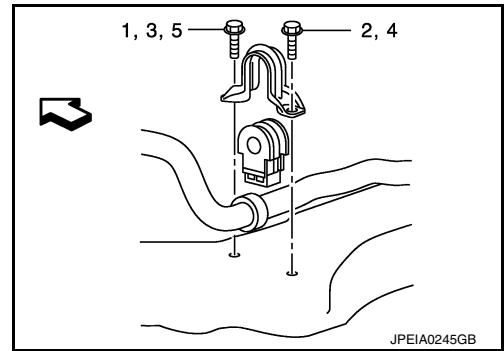

4. To connect the stabilizer connecting rod (1), tighten the nut while holding the hexagonal part (A) on the stabilizer connecting rod.

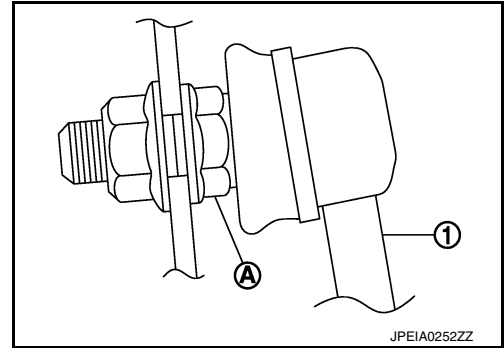

5. Perform the final tightening of the nuts and bolts under unladen conditions with the tires on level ground.

INSPECTION AFTER INSTALLATION

1. Check the wheel alignment. Refer to [FSU-7. "Inspection"](#).
2. Perform the steering angle sensor neutral position adjustment. Refer to [BRC-72. "Work Procedure"](#).

A
B
C
D
FSU
F
G
H
I
J
K
L
M
N
O
P

STEERING KNUCKLE

< REMOVAL AND INSTALLATION >

STEERING KNUCKLE

Exploded View

INFOID:000000012427631

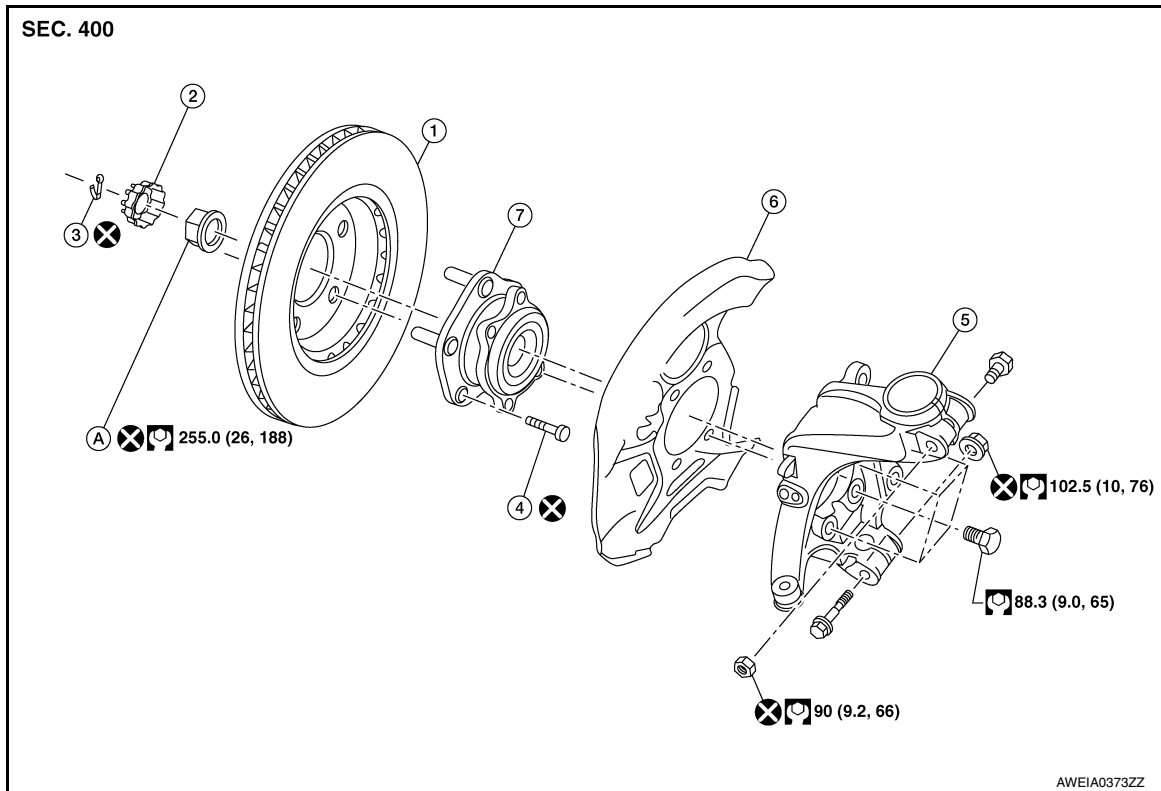

- | | | |
|--------------------------|-----------------------|-----------------|
| 1. Disc brake rotor | 2. Nut retainer | 3. Cotter pin |
| 4. Wheel stud | 5. Steering knuckle | 6. Splash guard |
| 7. Wheel hub and bearing | A. Wheel hub lock nut | |

Removal and Installation

INFOID:000000012427632

REMOVAL

1. Remove the wheel and tire using power tool. Refer to [WT-67, "Removal and Installation"](#).

2. Remove the (1) bolt and separate the front wheel sensor from the steering knuckle. Refer to [BRC-181, "FRONT WHEEL SENSOR : Exploded View"](#).

CAUTION:

- Failure to separate the front wheel sensor from the steering knuckle may result in damage to the front wheel sensor.
- Pull out the front wheel sensor, being careful to turn it as little as possible. Do not pull on wheel sensor harness.

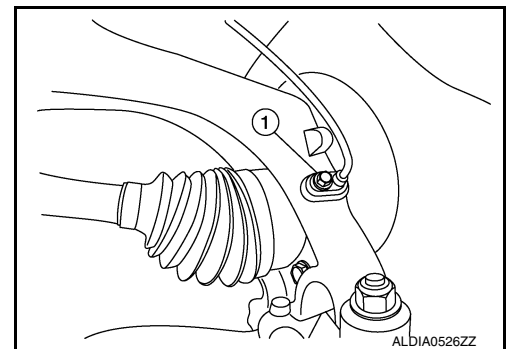

3. Remove brake caliper torque member bolts, leaving the brake hose attached. Position brake caliper aside with wire. Refer to [BR-37, "BRAKE CALIPER ASSEMBLY \(1 PISTON TYPE\) : Exploded View"](#) (1 PISTON TYPE), or [BR-41, "BRAKE CALIPER ASSEMBLY \(2 PISTON TYPE\) : Exploded View"](#) (2 PISTON TYPE).

CAUTION:

Do not depress brake pedal while brake caliper is removed.

STEERING KNUCKLE

< REMOVAL AND INSTALLATION >

- Put alignment marks (A) on the disc brake rotor and on the wheel hub and bearing. Remove the disc brake rotor.

CAUTION:

Do not drop the disc brake rotor.

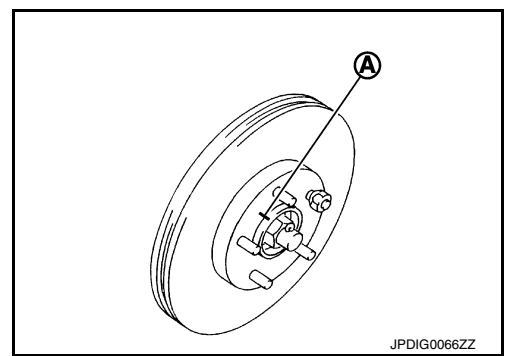

- Remove the cotter pin from the drive shaft.
- Remove the nut retainer from the wheel hub lock nut.
- Loosen the wheel hub lock nut using power tool.
- Using a piece of wood and a suitable tool, tap on the lock nut to disengage the drive shaft from the wheel hub and bearing.

CAUTION:

- Do not place the drive shaft joint at an extreme angle. Be careful not to over extend the slide joint.**
- Do not allow the drive shaft to hang without support.**

NOTE:

Use a suitable puller if drive shaft cannot be separated from the wheel hub and bearing.

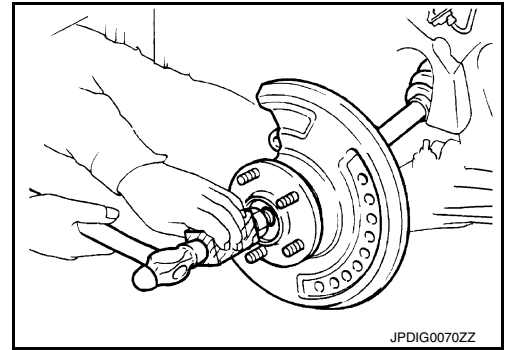

- Remove the wheel hub lock nut. Refer to [FAX-9, "Exploded View"](#) (FWD) or to [FAX-47, "Exploded View"](#) (AWD).
- Remove the nut and separate the stabilizer connecting rod from the strut bracket. Refer to [FSU-15, "Exploded View"](#).
- Remove the lower nut and bolt from the steering knuckle. Separate the transverse link from the steering knuckle. Refer to [FSU-18, "Exploded View"](#).
- Separate drive shaft from wheel hub and bearing.
- Remove the bolts and the wheel hub and bearing and splash guard from the steering knuckle.
- Remove the upper nut and bolt from the steering knuckle.
- Remove the nut and separate the outer socket from the steering knuckle. Refer to [ST-21, "Exploded View"](#).

STEERING KNUCKLE

< REMOVAL AND INSTALLATION >

16. Open the slot using a suitable tool (A). Separate the steering knuckle (1) from the front coil spring and strut.

CAUTION:

Do not drop steering knuckle.

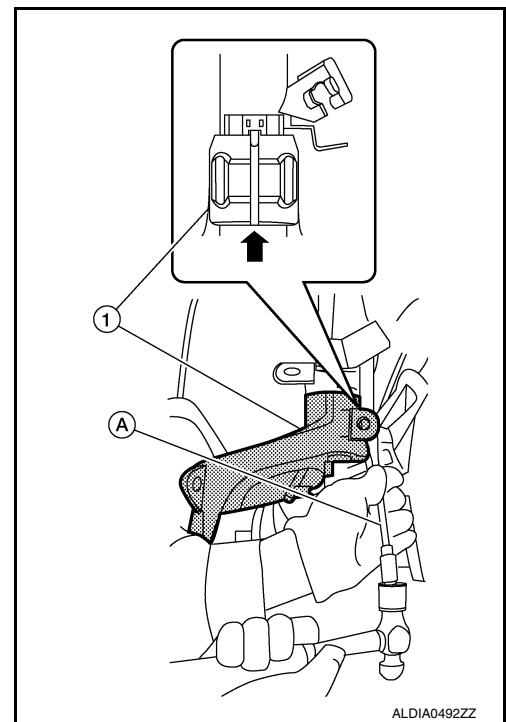

ALDIA0492ZZ

INSPECTION AFTER REMOVAL

Check for deformity, cracks and damage on each part, replace if necessary.

INSTALLATION

Installation is in the reverse order of removal.

CAUTION:

- Do not reuse the wheel hub lock nut.
- Do not reuse the cotter pin.
- Do not reuse steering knuckle upper bolt nut.
- Do not reuse steering knuckle lower nut.
- Check the wheel alignment. Refer to [FSU-7, "Inspection"](#).
- Adjust the neutral position of the steering angle sensor. Refer to [BRC-72, "Work Procedure"](#).

FRONT SUSPENSION MEMBER

< UNIT REMOVAL AND INSTALLATION >

UNIT REMOVAL AND INSTALLATION

FRONT SUSPENSION MEMBER

Exploded View

INFOID:0000000012427633

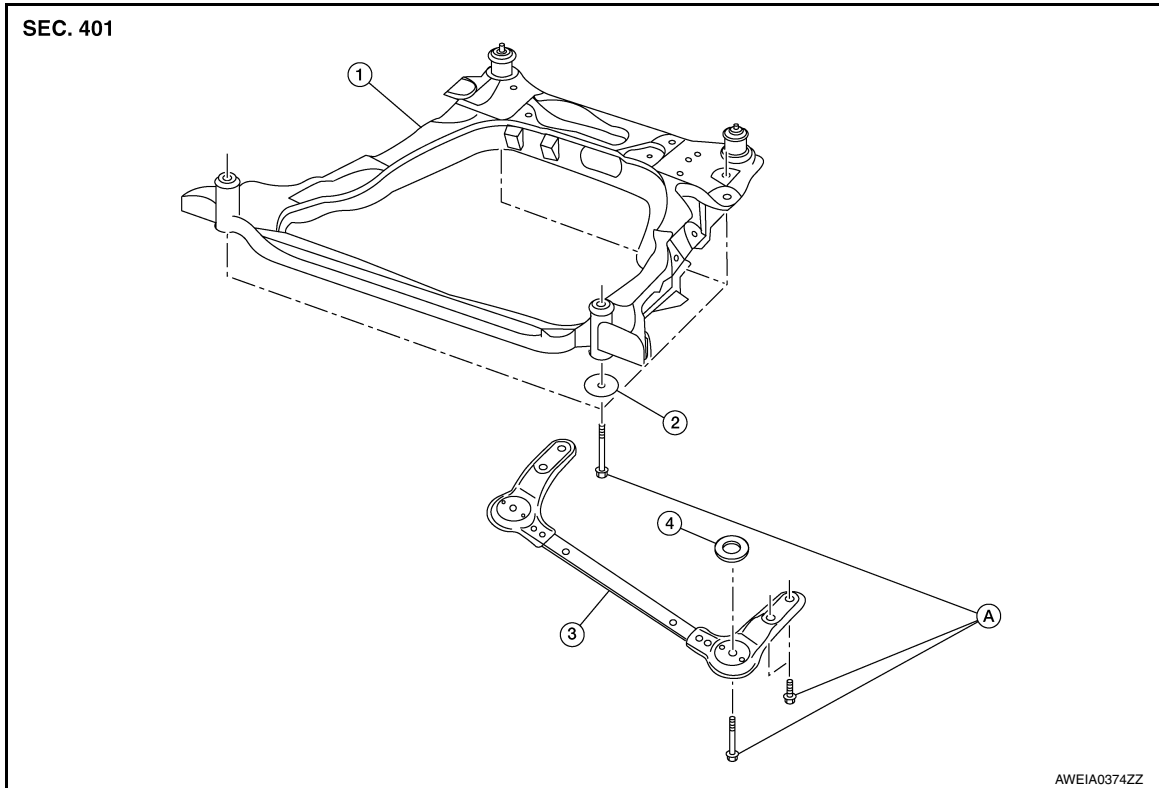

- | | | |
|----------------------------|------------------------------|---------------------------------|
| 1. Front suspension member | 2. Rebound insulator stopper | 3. Front suspension member stay |
| 4. Rebound stopper | A. Refer to installation. | |

Removal and Installation

INFOID:0000000012427634

REMOVAL

1. Remove the column hole cover. Refer to [ST-12, "Exploded View"](#).
2. Remove bolt and separate steering column from steering gear pinion shaft.
CAUTION:
With the steering linkage disconnected, the spiral cable may snap by turning the steering wheel beyond the limited number of turns. Secure the steering wheel during removal of the front suspension member.
3. Remove the fender protector (LH/RH). Refer to [EXT-29, "FENDER PROTECTOR : Removal and Installation"](#).
4. Remove the nut and separate the stabilizer connecting rod from the stabilizer bar (LH/RH). Refer to [FSU-15, "Exploded View"](#).
5. Remove the nut and separate the outer socket from the steering knuckle (LH/RH). Refer to [ST-21, "Exploded View"](#).
6. Remove the nut and bolt and separate the transverse link from steering knuckle (LH/RH). Refer to [FSU-18, "Exploded View"](#).
7. Remove front exhaust mount. Refer to [EX-5, "Exploded View"](#).
8. Disconnect heated oxygen sensor 2. Refer to [EX-5, "Exploded View"](#).
9. Remove oxygen sensor bracket.
10. Remove rear torque rod. Refer to [EM-86, "Exploded View"](#).

FRONT SUSPENSION MEMBER

< UNIT REMOVAL AND INSTALLATION >

11. Set suitable jack under front suspension member.
12. Remove bolts and remove front suspension member stay from vehicle.
13. Remove bolts and nuts from front suspension member.
14. Gradually lower jack to remove front suspension member from vehicle.

CAUTION:

Secure front suspension member to suitable jack while removing it.

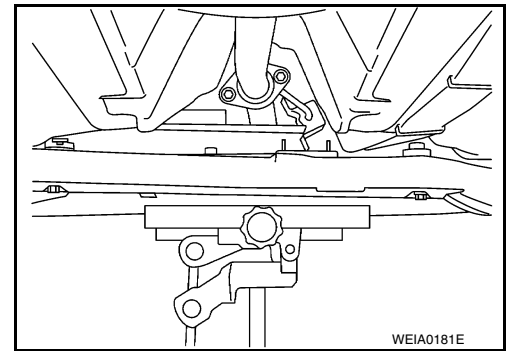

15. If necessary, remove bolts and nuts, and then remove transverse link, stabilizer bar, and steering gear from front suspension member.

INSPECTION AFTER REMOVAL

Check the front suspension member for significant deformation, cracks, or damages. Replace it if necessary.

INSTALLATION

Installation is in the reverse order of removal.

CAUTION:

- With the steering linkage disconnected, the spiral cable may snap by turning the steering wheel beyond the limited number of turns. Secure the steering wheel during installation of the front suspension member.
- When connecting the steering column (1) to the steering gear pinion shaft (2), be sure that the gap (A) lines up with the joint retaining bolt hole.
- Make sure the bolt is in the correct direction, as shown, and is securely seated in the groove.

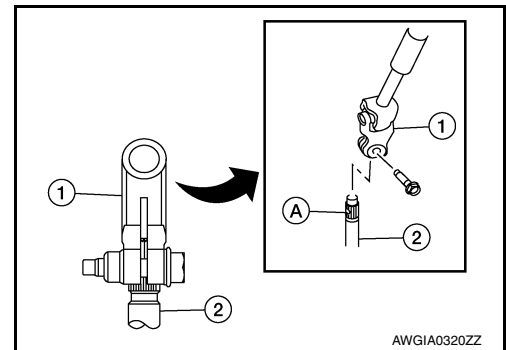

NOTE:

When replacing front suspension member with new parts, make sure to replace stabilizer clamp with new part (Korea production only).

- Install the suspension member bolts in the order shown.

Temporary tightening : 1 → 2
 Final tightening (Specified torque) : 3 → 6

Bolts 3-5 94 N·m (9.6 kg-m, 69 ft-lb)
Bolts 6 76 N·m (7.8 kg-m, 56 ft-lb)

⇐ : Front

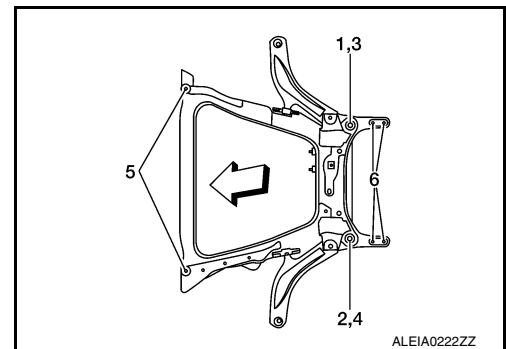

- Perform final tightening of installation position between front suspension member and transverse links (rubber bushing) under unladen condition with tires on level ground.
- Check wheel sensor harness for proper connection. Refer to [BRC-181. "FRONT WHEEL SENSOR : Exploded View"](#).

INSPECTION AFTER INSTALLATION

- Check wheel alignment. Refer to [FSU-7. "Inspection"](#).
- Adjust the neutral position of the steering angle sensor. Refer to [BRC-72. "Work Procedure"](#).

FRONT COIL SPRING AND STRUT

< UNIT DISASSEMBLY AND ASSEMBLY >

UNIT DISASSEMBLY AND ASSEMBLY

FRONT COIL SPRING AND STRUT

Exploded View

INFOID:0000000012427635

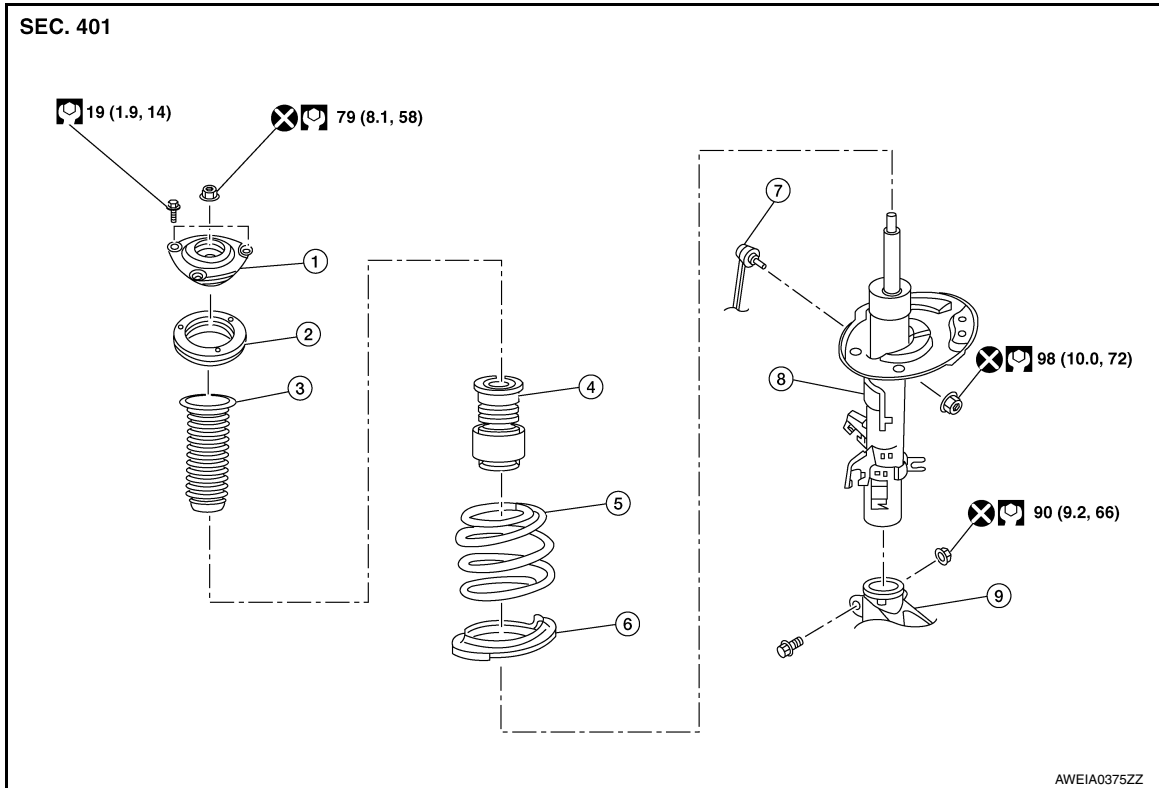

- | | | |
|----------------------------------|------------------------|-----------------------------------|
| 1. Strut mount insulator | 2. Strut mount bearing | 3. Front spring upper rubber seat |
| 4. Front suspension bound bumper | 5. Front coil spring | 6. Front spring lower rubber seat |
| 7. Stabilizer connecting rod | 8. Strut | 9. Steering knuckle |

Disassembly and Assembly

INFOID:0000000012427636

DISASSEMBLY

CAUTION:

Do not damage the piston rod when removing components from the front coil spring and strut.

1. Install Tool (A) to the front coil spring and strut.

CAUTION:

When installing Tool (A), wrap a shop cloth around the front coil spring and strut to protect the parts from damage.

Tool number : ST35652000 (-)

2. Secure Tool (A) in a vise.

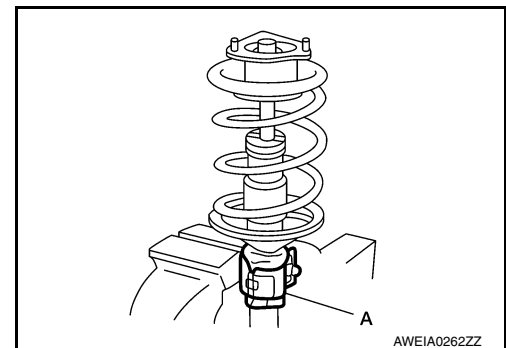

3. Install a suitable tool to strut rod.
4. Slightly loosen the piston rod lock nut.

WARNING:

FRONT COIL SPRING AND STRUT

< UNIT DISASSEMBLY AND ASSEMBLY >

Do not remove the piston rod lock nut completely. If the piston rod lock nut is removed completely, the front coil spring can jump out and may cause serious damage or injury.

5. Compress the front coil spring using a suitable tool (A).

WARNING:

Make sure that the pawls of the suitable tool are firmly hooked on the front coil spring. The suitable tool must be tightened alternately so as to not tilt the front coil spring.

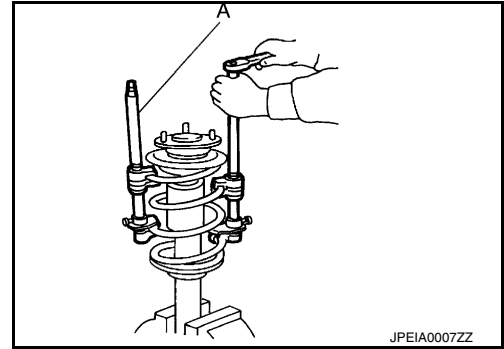

6. Make sure front coil spring is free between the strut mount insulator and the front spring lower rubber seat.
7. Hold the piston rod and remove the piston rod lock nut.
8. Remove strut mount insulator and strut mount bearing, front spring upper seat, and front suspension bound bumper from strut.
9. Gradually release the suitable tool and remove the front coil spring.

CAUTION:

Release the suitable tool while making sure the position of the suitable tool on the front coil spring does not move.

10. Remove front spring lower rubber seat.
11. Remove the suitable tool from strut, and inspect the components. Refer to [FSU-6. "Inspection"](#).

INSPECTION AFTER DISASSEMBLY

Strut

- Check strut for deformation, cracks, and damage, and replace if necessary.
- Check piston rod for damage, uneven wear, and distortion, and replace if necessary.
- Check welded and sealed areas for oil leakage, and replace if necessary.

Insulator and Rubber Parts

Check strut mount insulator for cracks, rubber parts for wear and replace if necessary.

Front Coil Spring

Check for cracks, wear, and damage and replace if necessary.

ASSEMBLY

CAUTION:

Do not damage the piston rod when installing components to the front coil spring and strut.

1. Install front spring lower rubber seat to the strut.
2. Compress the front coil spring using a suitable tool.

WARNING:

Make sure that the pawls of the suitable tool are firmly hooked on the front coil spring. The suitable tool must be tightened alternately so as to not tilt the front coil spring.

3. Align the lower end of the front coil spring (1) with the front spring lower rubber seat (2) as shown.

Maximum Gap (A) : 5 mm (0.2 in)

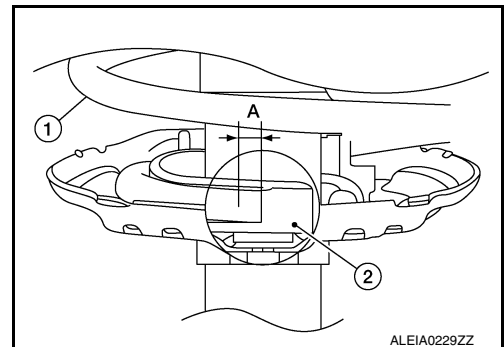

FRONT COIL SPRING AND STRUT

< UNIT DISASSEMBLY AND ASSEMBLY >

4. Connect the front suspension bound bumper to the strut mount bearing and front spring upper rubber seat, then place over strut piston rod.

CAUTION:

- Be sure to install the front suspension bound bumper to the strut mount bearing and front spring upper rubber seat securely.
- When installing front suspension the bound bumper, use soapy water. Do not use machine oil or other lubricants.

5. Install front spring upper rubber seat to the front coil spring. Align the upper end of the front coil spring (1) with the front spring upper rubber seat (2) as shown.

Maximum Gap (A) : 5 mm (0.2 in)

CAUTION:

Do not apply oil, such as grease, when installing the strut mount bearing.

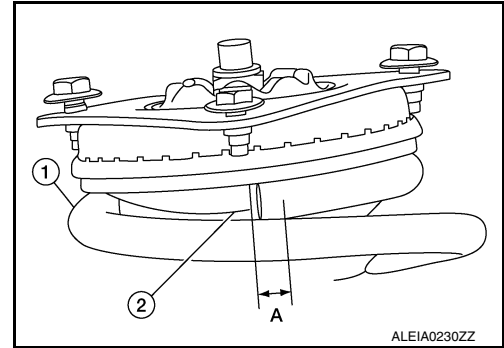

6. Temporarily install piston rod lock nut.

CAUTION:

Do not reuse piston rod lock nut.

7. Gradually release the suitable tool (A) and remove the suitable tool from the front coil spring.

CAUTION:

Release the suitable tool while making sure the position of the suitable tool on the front coil spring does not move.

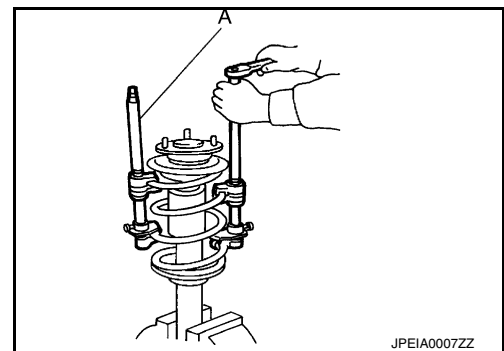

8. Tighten the piston rod lock nut to the specified torque. Refer to [FSU-23. "Exploded View"](#).

9. Remove Tool (A) from the vise.

10. Remove Tool (A) from the front coil spring and strut.

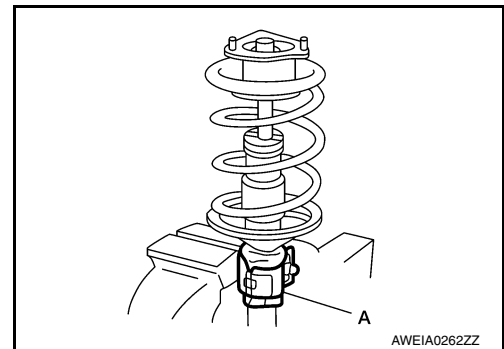

11. After replacing strut, always follow the disposal procedure to discard the old strut. Refer to [FSU-25. "Disposal"](#).

Disposal

INFOID:000000012427637

1. Set front coil spring and strut horizontally to the ground with the piston rod fully extracted.

FRONT COIL SPRING AND STRUT

< UNIT DISASSEMBLY AND ASSEMBLY >

2. Drill 2 – 3 mm (0.08 – 0.12 in) hole at the position (●) from top as shown to release gas gradually.

CAUTION:

- Wear eye protection (safety glasses).
- Wear gloves.
- Be careful with metal chips or oil blown out by the compressed gas.

NOTE:

- Drill vertically in this direction (←) directly to the outer tube avoiding brackets.
- The gas is clear, colorless, odorless, and harmless.

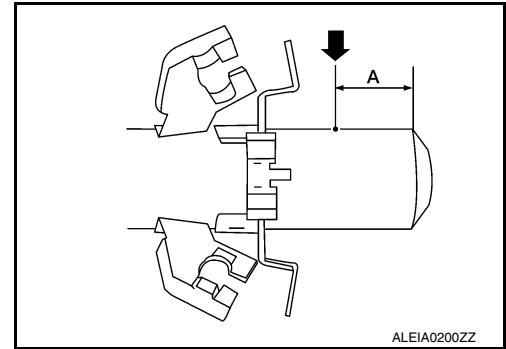

A: 20 – 30 mm (0.79 – 1.18 in)

3. Position the drilled hole downward and drain oil by moving the piston rod several times.

CAUTION:

Dispose of drained oil according to the law and local regulations.

SERVICE DATA AND SPECIFICATIONS (SDS)

< SERVICE DATA AND SPECIFICATIONS (SDS)

SERVICE DATA AND SPECIFICATIONS (SDS)

SERVICE DATA AND SPECIFICATIONS (SDS)

Wheel Alignment (Unladen*1)

INFOID:0000000012427638

Axle type		FWD			AWD	
		2 ROW		3 ROW	2 ROW	3 ROW
Body type		2 ROW		3 ROW	2 ROW	3 ROW
Wheel diameter		17 inch	18 inch	17 inch	17 or 18 inch	17 inch
Camber Degree minute (Decimal degree)	Minimum	-1° 19' (-1.32°)			-1° 14' (-1.23°)	
	Nominal	-0° 34' (-0.57°)			-0° 29' (-0.48°)	
	Maximum	0° 11' (0.18°)			0° 16' (0.27°)	
	(LH) and (RH) difference	± 0° 35' (± 0.60°)				
Caster Degree minute (Decimal degree)	Minimum	4° 56' (4.93°)	4° 57' (4.95°)	5° 00' (5.00°)	4° 51' (4.85°)	4° 54' (4.90°)
	Nominal	5° 41' (5.68°)	5° 42' (5.70°)	5° 45' (5.75°)	5° 36' (5.60°)	5° 39' (5.65°)
	Maximum	6° 26' (6.43°)	6° 27' (6.45°)	6° 30' (6.50°)	6° 21' (6.35°)	6° 24' (6.40°)
	(LH) and (RH) difference	± 0° 35' (± 0.60°)				
Kingpin inclination Degree minute (Decimal degree)	Minimum	11° 05' (11.10°)			10° 55' (10.92°)	10° 50' (10.83°)
	Nominal	11° 50' (11.85°)			11° 40' (11.67°)	11° 35' (11.58°)
	Maximum	12° 35' (12.60°)			12° 25' (12.42°)	12° 20' (12.33°)

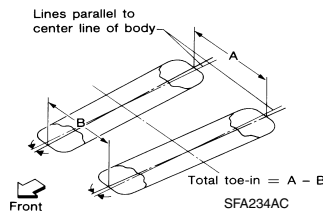

Total toe-in	Distance (A - B)	Minimum	Out 0.5 mm (Out 0.02 in)
		Nominal	In 1.5 mm (In 0.08 in)
		Maximum	In 3.5 mm (In 0.14 in)
	Angle (LH and RH) Degree minute (Decimal degree)	Minimum	Out 0° 2' (Out 0.04°)
		Nominal	In 0° 7' (In 0.12°)
		Maximum	In 0° 17' (In 0.28°)

*1: Fuel, engine coolant, and lubricants are full. Spare tire, jack, hand tools, and mats are in designated positions.

Ball Joint

INFOID:0000000012427639

Item		Standard
Swinging torque	Transverse link	0.5 – 3.4 N·m (0.05 – 0.35 kg·m, 4 – 30 in·lb)
Rotating torque	Transverse link	0.5 – 3.4 N·m (0.05 – 0.35 kg·m, 4 – 30 in·lb)
Axial end play		0 mm (0 in)

SERVICE DATA AND SPECIFICATIONS (SDS)

< SERVICE DATA AND SPECIFICATIONS (SDS)

Wheelarch Height (Unladen*)

INFOID:000000012427640

Unit: mm (in)

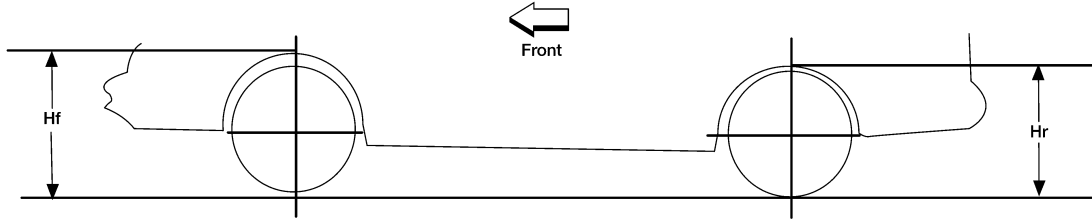

LEIA0085E

Axle type	FWD			AWD		
Body type	2 ROW		3 ROW	2 ROW		3 ROW
Tire size	225/65R17	225/60R18	225/65R17 RF	225/65R17	225/60R18	225/65R17 RF
Front (Hf)	788 (31.02)	790 (31.10)	790 (31.10)	797 (31.38)	799 (31.46)	800 (31.50)
Rear (Hr)	785 (30.91)	787 (30.98)	786 (30.94)	794 (31.26)	796 (31.34)	795 (31.30)

*: Fuel, engine coolant, and lubricants are full. Spare tire, jack, hand tools, and mats are in designated positions.