

SECTION **INT**
INTERIOR

A
B
C
D
E
F
G
H
I
INT
K
L
M
N
O
P

CONTENTS

PRECAUTION	3	CENTER PILLAR UPPER FINISHER : Removal and Installation	21
PRECAUTIONS	3	CENTER PILLAR LOWER FINISHER	22
Precaution for Supplemental Restraint System (SRS) "AIR BAG" and "SEAT BELT PRE-TENSIONER"	3	CENTER PILLAR LOWER FINISHER : Removal and Installation	22
Precaution for Work	3	BODY SIDE WELT	23
PREPARATION	4	BODY SIDE WELT : Removal and Installation - Front Door Welt	23
PREPARATION	4	BODY SIDE WELT : Removal and Installation - Rear Door Welt	23
Special Service Tool	4	KICKING PLATE	23
Commercial Service Tools	4	KICKING PLATE : Removal and Installation - Front Kicking Plate	23
CLIP LIST	5	KICKING PLATE : Removal and Installation - Rear Kicking Plate	24
Descriptions for Clips	5	DASH SIDE FINISHER	24
SYMPTOM DIAGNOSIS	9	DASH SIDE FINISHER : Removal and Installation	24
SQUEAK AND RATTLE TROUBLE DIAGNOSES	9	FLOOR TRIM	26
Work Flow	9	Exploded View	26
Generic Squeak and Rattle Troubleshooting	10	Removal and Installation	26
Diagnostic Worksheet	13	HEADLINING	29
REMOVAL AND INSTALLATION	15	Exploded View	29
FRONT DOOR FINISHER	15	Removal and Installation	30
Exploded View	15	LUGGAGE TRIM	33
Removal and Installation	15	Exploded View	33
REAR DOOR FINISHER	18	LUGGAGE SIDE LOWER FINISHER	34
Exploded View	18	LUGGAGE SIDE LOWER FINISHER : Removal and Installation - With Third Row Seat	34
Removal and Installation	18	LUGGAGE SIDE LOWER FINISHER : Removal and Installation - Without Third Row Seat	35
BODY SIDE TRIM	20	LUGGAGE SIDE UPPER FINISHER	36
Exploded View	20	LUGGAGE SIDE UPPER FINISHER : Removal and Installation	36
FRONT PILLAR FINISHER	20		
FRONT PILLAR FINISHER : Removal and Installation	20		
CENTER PILLAR UPPER FINISHER	21		

LUGGAGE REAR PLATE	37	BACK DOOR FINISHER	38
LUGGAGE REAR PLATE : Removal and Installation	37	Exploded View	38
		Removal and Installation	38

PRECAUTIONS

< PRECAUTION >

PRECAUTION

PRECAUTIONS

Precaution for Supplemental Restraint System (SRS) "AIR BAG" and "SEAT BELT PRE-TENSIONER"

INFOID:000000012424587

The Supplemental Restraint System such as "AIR BAG" and "SEAT BELT PRE-TENSIONER", used along with a front seat belt, helps to reduce the risk or severity of injury to the driver and front passenger for certain types of collision. Information necessary to service the system safely is included in the SR and SB section of this Service Manual.

WARNING:

- To avoid rendering the SRS inoperative, which could increase the risk of personal injury or death in the event of a collision which would result in air bag inflation, all maintenance must be performed by an authorized NISSAN/INFINITI dealer.
- Improper maintenance, including incorrect removal and installation of the SRS, can lead to personal injury caused by unintentional activation of the system. For removal of Spiral Cable and Air Bag Module, see the SR section.
- Do not use electrical test equipment on any circuit related to the SRS unless instructed to in this Service Manual. SRS wiring harnesses can be identified by yellow and/or orange harnesses or harness connectors.

PRECAUTIONS WHEN USING POWER TOOLS (AIR OR ELECTRIC) AND HAMMERS

WARNING:

- When working near the Airbag Diagnosis Sensor Unit or other Airbag System sensors with the Ignition ON or engine running, DO NOT use air or electric power tools or strike near the sensor(s) with a hammer. Heavy vibration could activate the sensor(s) and deploy the air bag(s), possibly causing serious injury.
- When using air or electric power tools or hammers, always switch the Ignition OFF, disconnect the battery and wait at least three minutes before performing any service.

Precaution for Work

INFOID:000000012424588

- When removing or disassembling each component, be careful not to damage or deform it. If a component may be subject to interference, be sure to protect it with a shop cloth.
- When removing (disengaging) components with a screwdriver or similar tool, be sure to wrap the component with a shop cloth or vinyl tape to protect it.
- Protect the removed parts with a shop cloth and prevent them from being dropped.
- Replace a deformed or damaged clip.
- If a part is specified as a non-reusable part, always replace it with a new one.
- Be sure to tighten bolts and nuts securely to the specified torque.
- After installation is complete, be sure to check that each part works properly.
- Follow the steps below to clean components:
 - Water soluble dirt:
 - Dip a soft cloth into lukewarm water, wring the water out of the cloth and wipe the dirty area.
 - Then rub with a soft, dry cloth.
 - Oily dirt:
 - Dip a soft cloth into lukewarm water with mild detergent (concentration: within 2 to 3%) and wipe the dirty area.
 - Then dip a cloth into fresh water, wring the water out of the cloth and wipe the detergent off.
 - Then rub with a soft, dry cloth.
 - Do not use organic solvent such as thinner, benzene, alcohol or gasoline.
 - For genuine leather seats, use a genuine leather seat cleaner.

PREPARATION

< PREPARATION >

PREPARATION

PREPARATION

Special Service Tool

INFOID:000000012424589

The actual shape of the tools may differ from those illustrated here.

Tool number (TechMate No.) Tool name	Description
— (J-39570) Chassis Ear	Locating the noise
— (J-50397) NISSAN Squeak and Rattle Kit	Repairing the cause of noise
— (J-46534) Trim Tool Set	Removing trim components

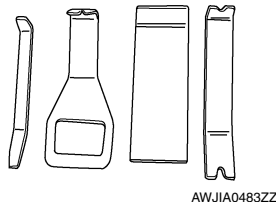
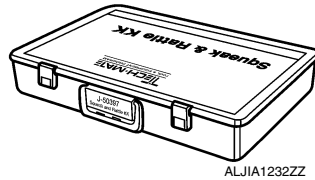
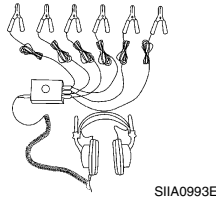

Commercial Service Tools

INFOID:000000012424590

(TechMate No.) Tool name	Description
(J-39565) Engine Ear	Locating the noise
(—) Power tool	Loosening nuts, screws and bolts

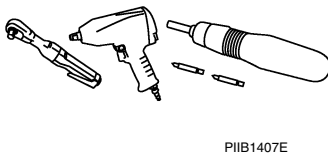
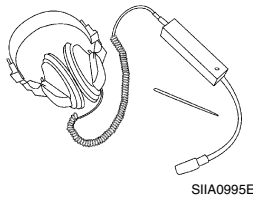

CLIP LIST







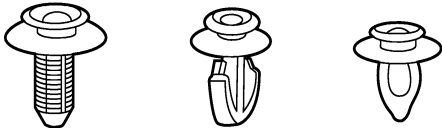

< PREPARATION >

CLIP LIST

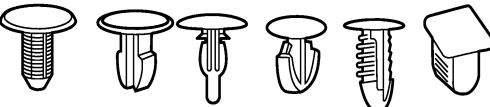
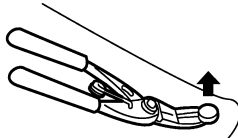
Descriptions for Clips

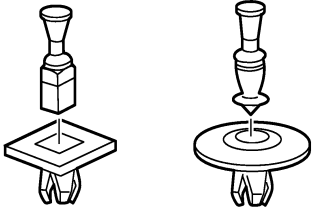
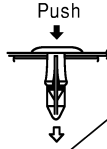
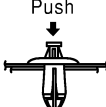
INFOID:000000012424591

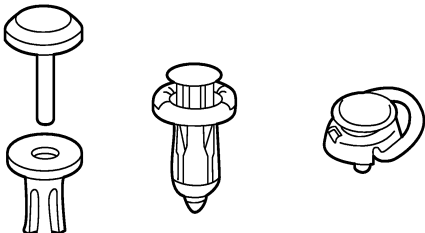
Replace any clips which are damaged during removal or installation.

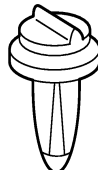
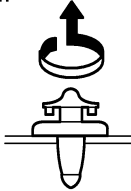







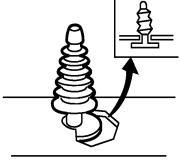
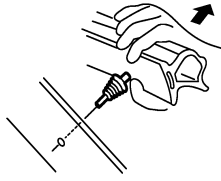

Symbol No.	Shapes	Removal & Installation
C101 		<p>Removal: Remove by bending up with flat-bladed screwdrivers or clip remover.</p> 
C103 		 <p>Removal: Remove with a clip remover.</p>
C203 		<p>Removal: Push center pin to catching position. (Do not remove center pin by hitting it.)</p> <p>Push</p>  <p>Push</p>  <p>Installation:</p>
C205 		<p>Removal: Flat-bladed screwdriver</p>  <p>Clip</p> <p>Finisher</p>
C206 		<p>Removal:</p> 

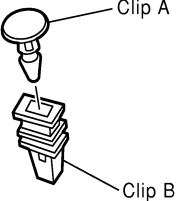
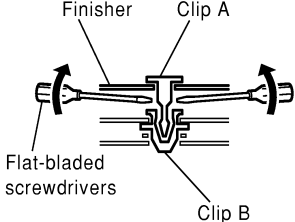
SIIA0315E

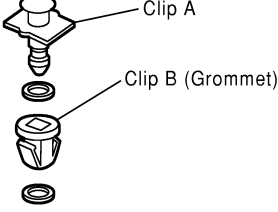
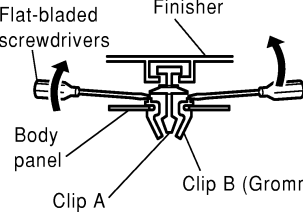
A
B
C
D
E
F
G
H
I
INT
K
L
M
N
O
P

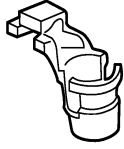
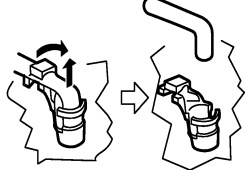
CLIP LIST

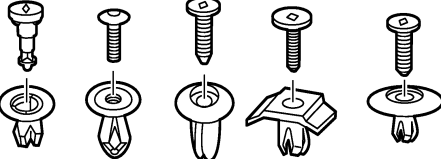









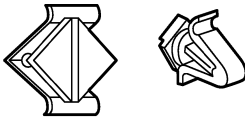

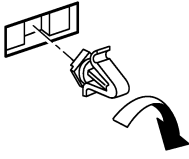
< PREPARATION >

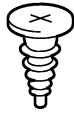
Symbol No.	Shapes	Removal & Installation
<p>CE103</p> 		<p>Removal:</p> 
<p>CF110</p> 		<p>Removal:</p> 
<p>CF118</p> 		<p>Removal:</p> 
<p>CR103</p> 		<p>Removal: Holder portion of clip must be spread out to remove rod.</p> 
<p>CS101</p> 		<p>Removal:</p> <ol style="list-style-type: none"> 1. Screw out with a Phillips screwdriver. 2. Remove female portion with flat-bladed screwdriver. 

SIIA0316E

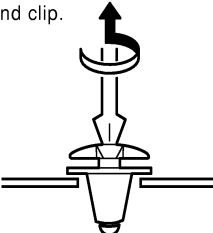
CLIP LIST

< PREPARATION >





Symbol No.	Shapes	Removal & Installation	
CG101 		Removal:  Rotate 45° to remove	Installation: 
CS102 			
CS113 		Removal: Disconnect upper connection of clip with a flat-bladed screwdriver, then remove clip while inserting a flat-bladed screwdriver between body panel and clip. 	
C111 			

SIIA0317E

A
B
C
D
E
F
G
H
I
INT
K
L
M
N
O
P

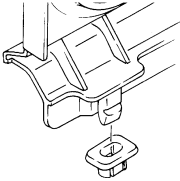
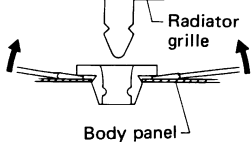
CLIP LIST

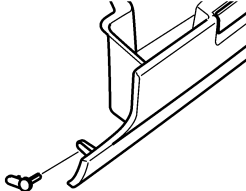
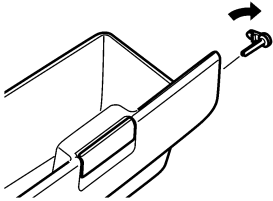
< PREPARATION >

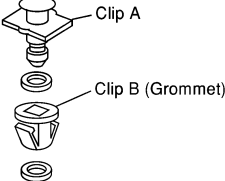
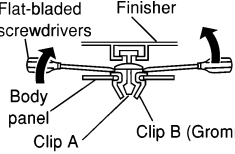
Symbol No.	Shapes	Removal & Installation
<p>CG104</p> 		<p>Removal: Remove by bending up with flat-bladed screwdrivers.</p>  <p>Radiator grille Body panel</p>
<p>CE114</p> 		
<p>CF118</p> 	 <p>Clip A Clip B (Grommet) Clip B (Grommet)</p>	<p>Removal: Flat-bladed screwdrivers Finisher screwdrivers</p>  <p>Body panel Clip A Clip B (Grommet)</p>

ALJIA0564GB

SQUEAK AND RATTLE TROUBLE DIAGNOSES

< SYMPTOM DIAGNOSIS >

SYMPTOM DIAGNOSIS

SQUEAK AND RATTLE TROUBLE DIAGNOSES

Work Flow

INFOID:0000000012424592

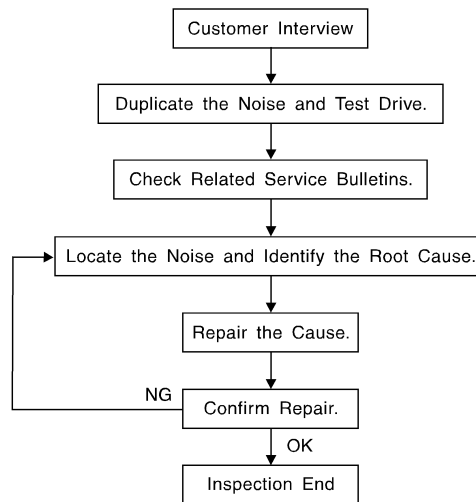

SBT842

CUSTOMER INTERVIEW

Interview the customer if possible, to determine the conditions that exist when the noise occurs. Use the Diagnostic Worksheet during the interview to document the facts and conditions when the noise occurs and any customer's comments; refer to [INT-13, "Diagnostic Worksheet"](#). This information is necessary to duplicate the conditions that exist when the noise occurs.

- The customer may not be able to provide a detailed description or the location of the noise. Attempt to obtain all the facts and conditions that exist when the noise occurs (or does not occur).
- If there is more than one noise in the vehicle, be sure to diagnose and repair the noise that the customer is concerned about. This can be accomplished by test driving the vehicle with the customer.
- After identifying the type of noise, isolate the noise in terms of its characteristics. The noise characteristics are provided so the customer, service adviser and technician are all speaking the same language when defining the noise.
- Squeak —(Like tennis shoes on a clean floor)
Squeak characteristics include the light contact/fast movement/brought on by road conditions/hard surfaces = higher pitch noise/softer surfaces = lower pitch noises/edge to surface = chirping.
- Creak—(Like walking on an old wooden floor)
Creak characteristics include firm contact/slow movement/twisting with a rotational movement/pitch dependent on materials/often brought on by activity.
- Rattle—(Like shaking a baby rattle)
Rattle characteristics include the fast repeated contact/vibration or similar movement/loose parts/missing clip or fastener/incorrect clearance.
- Knock —(Like a knock on a door)
Knock characteristics include hollow sounding/sometimes repeating/often brought on by driver action.
- Tick—(Like a clock second hand)
Tick characteristics include gentle contacting of light materials/loose components/can be caused by driver action or road conditions.
- Thump—(Heavy, muffled knock noise)
Thump characteristics include softer knock/dead sound often brought on by activity.
- Buzz—(Like a bumble bee)
Buzz characteristics include high frequency rattle/firm contact.
- Often the degree of acceptable noise level will vary depending upon the person. A noise that you may judge as acceptable may be very irritating to the customer.
- Weather conditions, especially humidity and temperature, may have a great effect on noise level.

DUPLICATE THE NOISE AND TEST DRIVE

SQUEAK AND RATTLE TROUBLE DIAGNOSES

< SYMPTOM DIAGNOSIS >

If possible, drive the vehicle with the customer until the noise is duplicated. Note any additional information on the Diagnostic Worksheet regarding the conditions or location of the noise. This information can be used to duplicate the same conditions when you confirm the repair.

If the noise can be duplicated easily during the test drive, to help identify the source of the noise, try to duplicate the noise with the vehicle stopped by doing one or all of the following:

- 1) Close a door.
 - 2) Tap or push/pull around the area where the noise appears to be coming from.
 - 3) Rev the engine.
 - 4) Use a floor jack to recreate vehicle "twist".
 - 5) At idle, apply engine load (electrical load, half-clutch on M/T model, drive position on CVT and A/T models).
 - 6) Raise the vehicle on a hoist and hit a tire with a rubber hammer.
- Drive the vehicle and attempt to duplicate the conditions the customer states exist when the noise occurs.
 - If it is difficult to duplicate the noise, drive the vehicle slowly on an undulating or rough road to stress the vehicle body.

CHECK RELATED SERVICE BULLETINS

After verifying the customer concern or symptom, check ASIST for Technical Service Bulletins (TSBs) related to that concern or symptom.

If a TSB relates to the symptom, follow the procedure to repair the noise.

LOCATE THE NOISE AND IDENTIFY THE ROOT CAUSE

1. Narrow down the noise to a general area. To help pinpoint the source of the noise, use a listening tool (Chassis Ear: J-39570, Engine Ear: J-39565 and mechanic's stethoscope).
2. Narrow down the noise to a more specific area and identify the cause of the noise by:
 - removing the components in the area that you suspect the noise is coming from.
Do not use too much force when removing clips and fasteners, otherwise clips and fasteners can be broken or lost during the repair, resulting in the creation of new noise.
 - tapping or pushing/pulling the component that you suspect is causing the noise.
Do not tap or push/pull the component with excessive force, otherwise the noise will be eliminated only temporarily.
 - feeling for a vibration with your hand by touching the component(s) that you suspect is (are) causing the noise.
 - placing a piece of paper between components that you suspect are causing the noise.
 - looking for loose components and contact marks.
Refer to [INT-10. "Generic Squeak and Rattle Troubleshooting"](#).

REPAIR THE CAUSE

- If the cause is a loose component, tighten the component securely.
- If the cause is insufficient clearance between components:
 - separate components by repositioning or loosening and retightening the component, if possible.
 - insulate components with a suitable insulator such as urethane pads, foam blocks, felt cloth tape or urethane tape. A NISSAN Squeak and Rattle Kit (J-50397) is available through your authorized NISSAN Parts Department.

CAUTION:

Do not use excessive force as many components are constructed of plastic and may be damaged.

NOTE:

- Always check with the Parts Department for the latest parts information.
- The materials contained in the NISSAN Squeak and Rattle Kit (J-50397) are listed on the inside cover of the kit; and can each be ordered separately as needed.
- The following materials not found in the kit can also be used to repair squeaks and rattles.
 - SILICONE GREASE: Use instead of UHMW tape that will be visible or does not fit. The silicone grease will only last a few months.
 - SILICONE SPRAY: Use when grease cannot be applied.
 - DUCT TAPE: Use to eliminate movement.

CONFIRM THE REPAIR

Confirm that the cause of a noise is repaired by test driving the vehicle. Operate the vehicle under the same conditions as when the noise originally occurred. Refer to the notes on the Diagnostic Worksheet.

Generic Squeak and Rattle Troubleshooting

INFOID:000000012424593

Refer to Table of Contents for specific component removal and installation information.

SQUEAK AND RATTLE TROUBLE DIAGNOSES

< SYMPTOM DIAGNOSIS >

INSTRUMENT PANEL

Most incidents are caused by contact and movement between:

1. Cluster lid A and the instrument panel
2. Acrylic lens and combination meter housing
3. Instrument panel to front pillar finisher
4. Instrument panel to windshield
5. Instrument panel pins
6. Wiring harnesses behind the combination meter
7. A/C defroster duct and duct joint

These incidents can usually be located by tapping or moving the components to duplicate the noise or by pressing on the components while driving to stop the noise. Most of these incidents can be repaired by applying felt cloth tape or silicone spray (in hard to reach areas). Urethane pads can be used to insulate wiring harness.

CAUTION:

Do not use silicone spray to isolate a squeak or rattle. If you saturate the area with silicone, you will not be able to recheck the repair.

CENTER CONSOLE

Components to pay attention to include:

1. Shift selector assembly cover to finisher
2. A/C control unit and cluster lid C
3. Wiring harnesses behind audio and A/C control unit

The instrument panel repair and isolation procedures also apply to the center console.

DOORS

Pay attention to the:

1. Finisher and inner panel making a slapping noise
2. Inside handle escutcheon to door finisher
3. Wiring harnesses tapping
4. Door striker out of alignment causing a popping noise on starts and stops

Tapping or moving the components or pressing on them while driving to duplicate the conditions can isolate many of these incidents. You can usually insulate the areas with felt cloth tape or insulator foam blocks from the NISSAN Squeak and Rattle Kit (J-50397) to repair the noise.

TRUNK

Trunk noises are often caused by a loose jack or loose items put into the trunk by the owner.

In addition look for:

1. Trunk lid bumpers out of adjustment
2. Trunk lid striker out of adjustment
3. The trunk lid torsion bars knocking together
4. A loose license plate or bracket

Most of these incidents can be repaired by adjusting, securing or insulating the item(s) or component(s) causing the noise.

SUNROOF/HEADLINING

Noises in the sunroof/headlining area can often be traced to one of the following:

1. Sunroof lid, rail, linkage or seals making a rattle or light knocking noise
2. Sun visor shaft shaking in the holder
3. Front or rear windshield touching headlining and squeaking

Again, pressing on the components to stop the noise while duplicating the conditions can isolate most of these incidents. Repairs usually consist of insulating with felt cloth tape.

OVERHEAD CONSOLE (FRONT AND REAR)

Overhead console noises are often caused by the console panel clips not being engaged correctly. Most of these incidents are repaired by pushing up on the console at the clip locations until the clips engage.

In addition look for:

A

B

C

D

E

F

G

H

I

INT

K

L

M

N

O

P

SQUEAK AND RATTLE TROUBLE DIAGNOSES

< SYMPTOM DIAGNOSIS >

1. Loose harness or harness connectors.
2. Front console map/reading lamp lens loose.
3. Loose screws at console attachment points.

SEATS

When isolating seat noise it's important to note the position the seat is in and the load placed on the seat when the noise is present. These conditions should be duplicated when verifying and isolating the cause of the noise.

Cause of seat noise include:

1. Headrest rods and holder
2. A squeak between the seat pad cushion and frame
3. The rear seatback lock and bracket

These noises can be isolated by moving or pressing on the suspected components while duplicating the conditions under which the noise occurs. Most of these incidents can be repaired by repositioning the component or applying urethane tape to the contact area.

UNDERHOOD

Some interior noise may be caused by components under the hood or on the engine wall. The noise is then transmitted into the passenger compartment.

Causes of transmitted underhood noise include:

1. Any component installed to the engine wall
2. Components that pass through the engine wall
3. Engine wall mounts and connectors
4. Loose radiator installation pins
5. Hood bumpers out of adjustment
6. Hood striker out of adjustment

These noises can be difficult to isolate since they cannot be reached from the interior of the vehicle. The best method is to secure, move or insulate one component at a time and test drive the vehicle. Also, engine rpm or load can be changed to isolate the noise. Repairs can usually be made by moving, adjusting, securing, or insulating the component causing the noise.

SQUEAK AND RATTLE TROUBLE DIAGNOSES

< SYMPTOM DIAGNOSIS >

Diagnostic Worksheet

INFOID:000000012424594

Dear Customer:

We are concerned about your satisfaction with your vehicle. Repairing a squeak or rattle sometimes can be very difficult. To help us fix your vehicle right the first time, please take a moment to note the area of the vehicle where the squeak or rattle occurs and under what conditions. You may be asked to take a test drive with a service advisor or technician to ensure we confirm the noise you are hearing.

SQUEAK & RATTLE DIAGNOSTIC WORKSHEET

I. WHERE DOES THE NOISE COME FROM? (circle the area of the vehicle)

The illustrations are for reference only, and may not reflect the actual configuration of your vehicle.

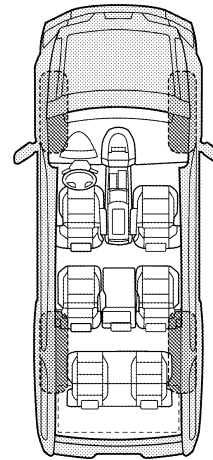
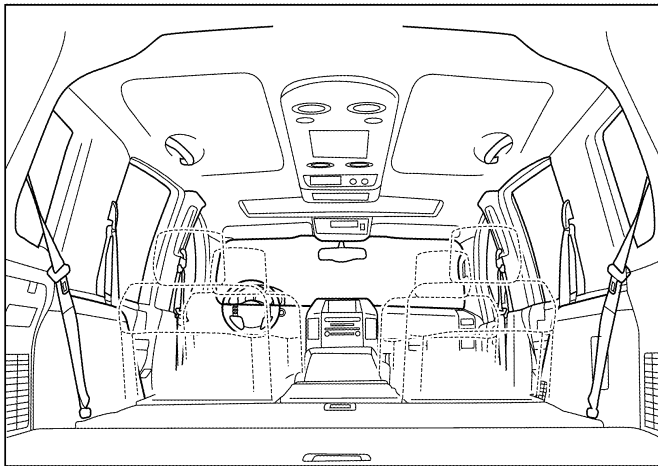
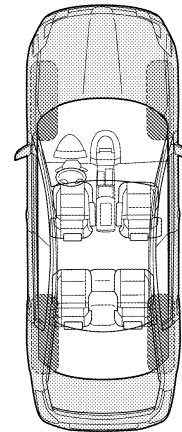
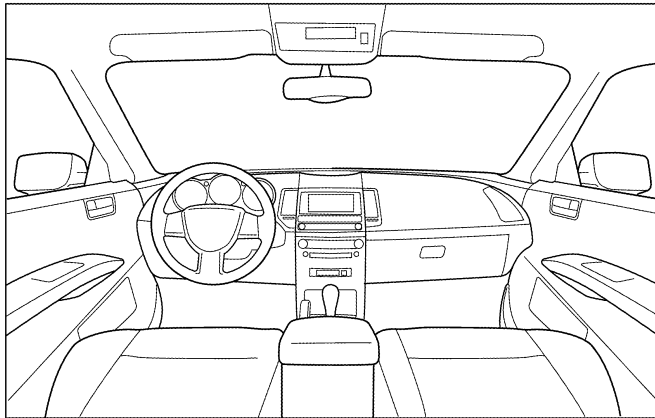

Continue to page 2 of the worksheet and briefly describe the location of the noise or rattle. In addition, please indicate the conditions which are present when the noise occurs.

A
B
C
D
E
F
G
H
I
INT
K
L
M
N
O
P

SQUEAK AND RATTLE TROUBLE DIAGNOSES

< SYMPTOM DIAGNOSIS >

SQUEAK & RATTLE DIAGNOSTIC WORKSHEET - page 2

Briefly describe the location where the noise occurs:

II. WHEN DOES IT OCCUR? (please check the boxes that apply)

- | | |
|---|--|
| <input type="checkbox"/> Anytime | <input type="checkbox"/> After sitting out in the rain |
| <input type="checkbox"/> 1st time in the morning | <input type="checkbox"/> When it is raining or wet |
| <input type="checkbox"/> Only when it is cold outside | <input type="checkbox"/> Dry or dusty conditions |
| <input type="checkbox"/> Only when it is hot outside | <input type="checkbox"/> Other: |

III. WHEN DRIVING:

- Through driveways
- Over rough roads
- Over speed bumps
- Only about ____ mph
- On acceleration
- Coming to a stop
- On turns: left, right or either (circle)
- With passengers or cargo
- Other: _____
- After driving ____ miles or ____ minutes

IV. WHAT TYPE OF NOISE

- Squeak (like tennis shoes on a clean floor)
- Creak (like walking on an old wooden floor)
- Rattle (like shaking a baby rattle)
- Knock (like a knock at the door)
- Tick (like a clock second hand)
- Thump (heavy muffled knock noise)
- Buzz (like a bumble bee)

TO BE COMPLETED BY DEALERSHIP PERSONNEL

Test Drive Notes:

	YES	NO	Initials of person performing
Vehicle test driven with customer	<input type="checkbox"/>	<input type="checkbox"/>	_____
- Noise verified on test drive	<input type="checkbox"/>	<input type="checkbox"/>	_____
- Noise source located and repaired	<input type="checkbox"/>	<input type="checkbox"/>	_____
- Follow up test drive performed to confirm repair	<input type="checkbox"/>	<input type="checkbox"/>	_____

VIN: _____ Customer Name _____
W.O.# _____ Date: _____

This form must be attached to Work Order

LAI0071E

FRONT DOOR FINISHER

< REMOVAL AND INSTALLATION >

REMOVAL AND INSTALLATION

FRONT DOOR FINISHER

Exploded View

INFOID:000000012424595

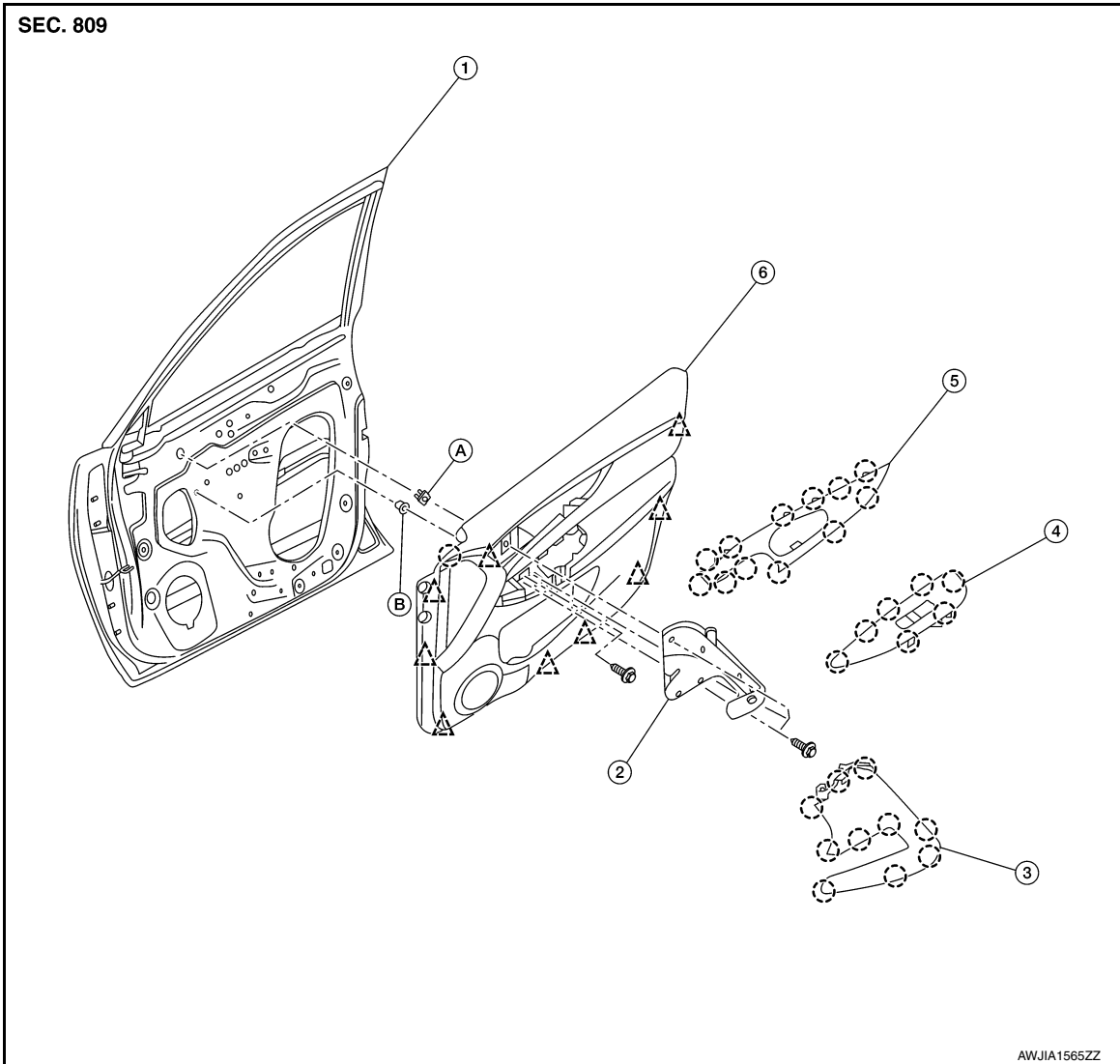

- | | | |
|---|--------------------------------------|---------------------------|
| 1. Front door | 2. Front door pull handle bracket | 3. Front door pull handle |
| 4. Main power window and door lock/unlock switch finisher or power window and door lock/unlock switch RH finisher | 5. Front door inside handle finisher | 6. Front door finisher |

A. Fastener

B. Grommet

 Clip

 Pawl

Removal and Installation

INFOID:000000012424596

REMOVAL

NOTE:

LH shown, RH similar.

FRONT DOOR FINISHER

< REMOVAL AND INSTALLATION >

1. Release pawls using a suitable tool (A) from front of inside handle finisher (1) while working toward the rear and remove.

⊖: Pawl

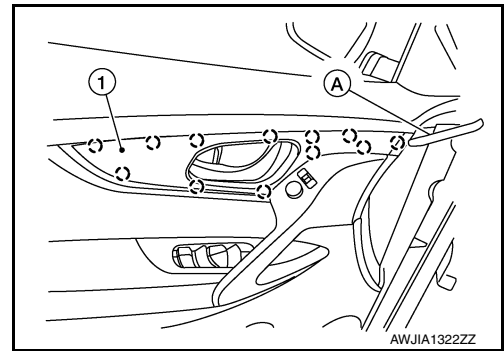

2. Release pawls using a suitable tool (A) from front of inside handle finisher (1) while working toward the rear and remove.

⊖: Pawl

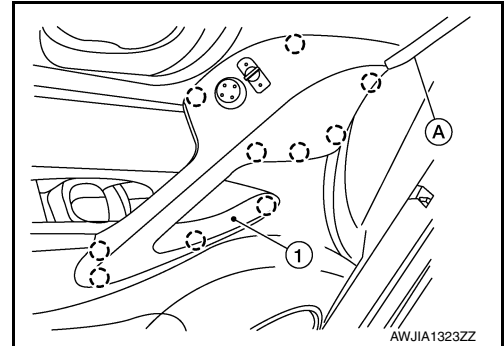

3. Disconnect harness connector from door mirror remote control switch (LH only).
4. Remove bolts (A) and front door inside pull handle bracket (1).

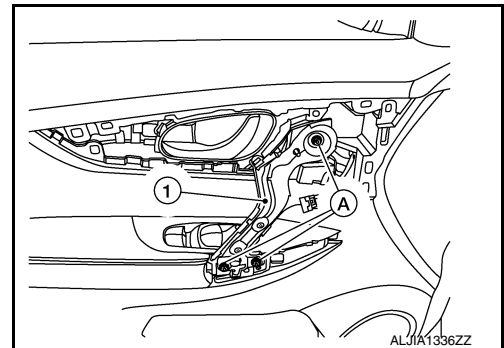

5. Release pawls using a suitable tool (A) and remove front door power window and door lock/unlock switch finisher (1).

⊖: Pawl

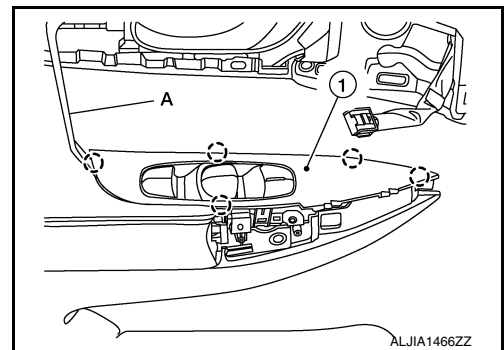

6. Disconnect harness connectors from front door power window and door lock/unlock switch.

FRONT DOOR FINISHER

< REMOVAL AND INSTALLATION >

7. Remove front door finisher bolt (A).

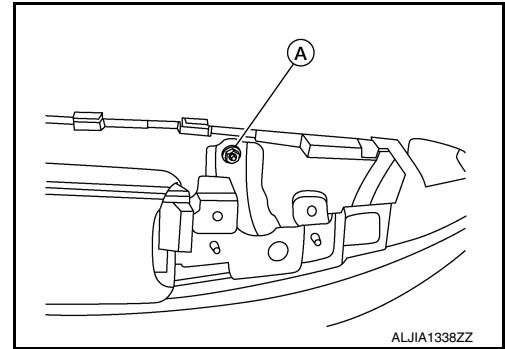

8. Insert suitable tool (A) between front door finisher and door panel to release clips and pawl, starting from the bottom and working to the top.

△: Clip

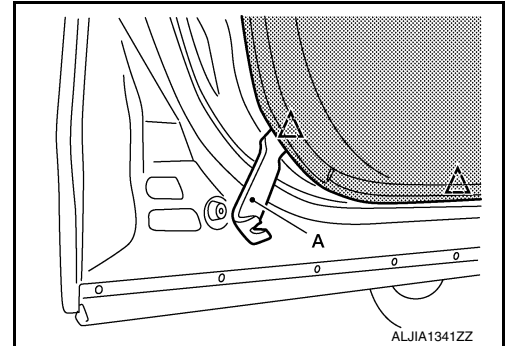

INSTALLATION

Installation is in the reverse order of removal.

CAUTION:

- Visually check the clips and pawls for deformation and damage during installation. Replace with new ones if necessary.
- When installing front door finisher, check that clips and pawls are securely placed in door panel holes.

NOTE:

When main power window and door lock/unlock switch or power window door lock/unlock switch RH is removed or replaced, it is necessary to perform the initialization procedure. Refer to [PWC-26. "Work Flow"](#).

A
B
C
D
E
F
G
H
I
INT
K
L
M
N
O
P

REAR DOOR FINISHER

< REMOVAL AND INSTALLATION >

REAR DOOR FINISHER

Exploded View

INFOID:000000012424597

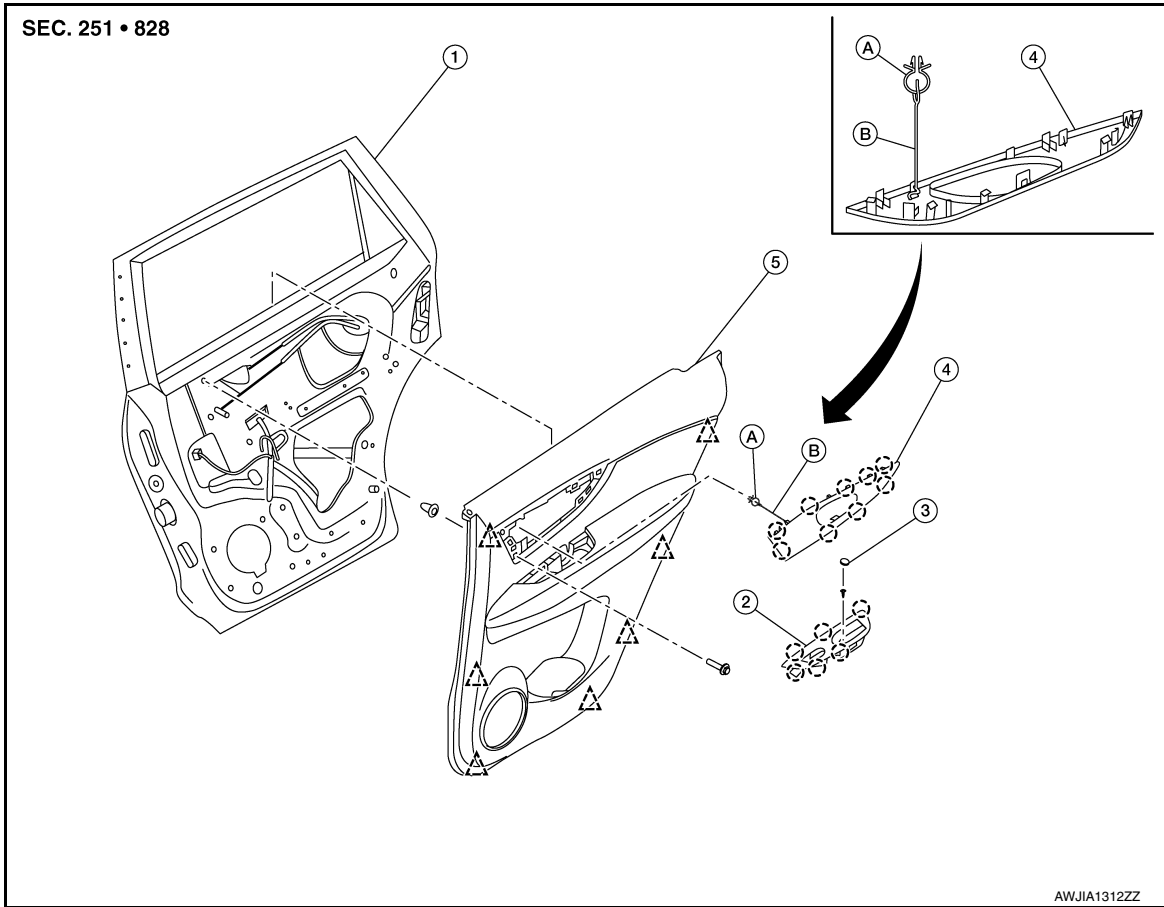

- | | | |
|-------------------------------------|--------------------------------------|--------------------------|
| 1. Rear door | 2. Rear power window switch finisher | 3. Rear door screw cover |
| 4. Rear door inside handle finisher | 5. Rear door finisher | A. Tether clip |
| B. Tether | ○ Pawl | △ Clip |

Removal and Installation

INFOID:000000012424598

REMOVAL

1. Remove screw cover (A).

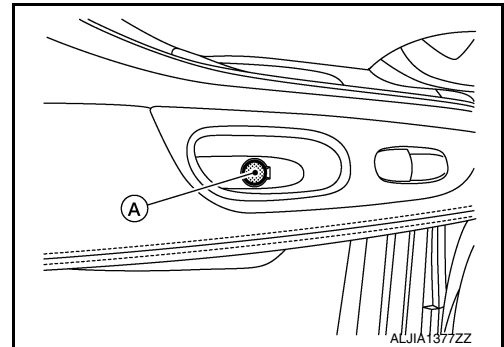

REAR DOOR FINISHER

< REMOVAL AND INSTALLATION >

2. Remove screw (A).

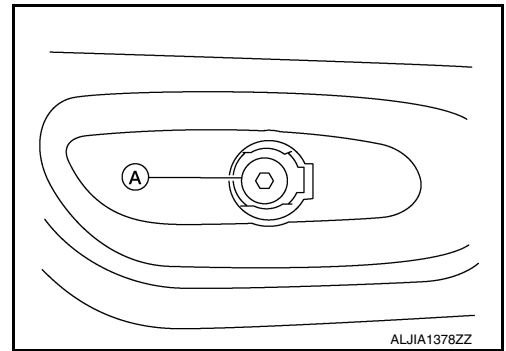

3. Release pawls using a suitable tool (A) and remove rear power window switch finisher (1).

○: Pawl

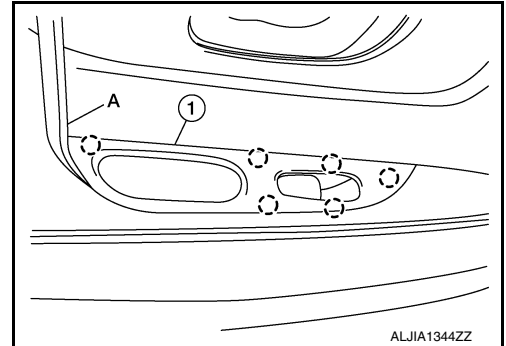

4. Disconnect harness connector from rear power window switch finisher.

5. Release pawls using a suitable tool (A) and remove rear door inside handle finisher (1).

○: Pawl

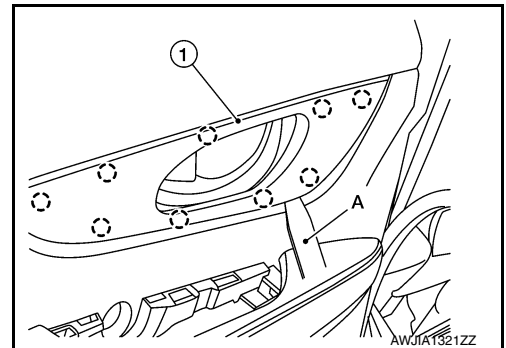

6. Release clip and remove tether from the front door panel.

7. Release clips using a suitable tool (A) and remove rear door finisher (1).

△: Clip

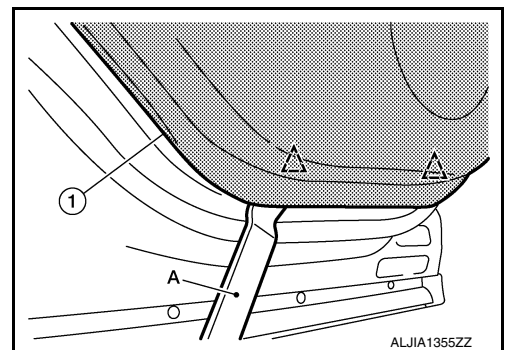

INSTALLATION

Installation is in the reverse order of removal.

CAUTION:

- Visually check the clips and pawls for deformation and damage during installation. Replace with new ones if necessary.
- When installing rear door finisher, check that clips and pawls are securely placed in door panel holes.

A
B
C
D
E
F
G
H
I
INT
K
L
M
N
O
P

BODY SIDE TRIM

< REMOVAL AND INSTALLATION >

BODY SIDE TRIM

Exploded View

INFOID:000000012424599

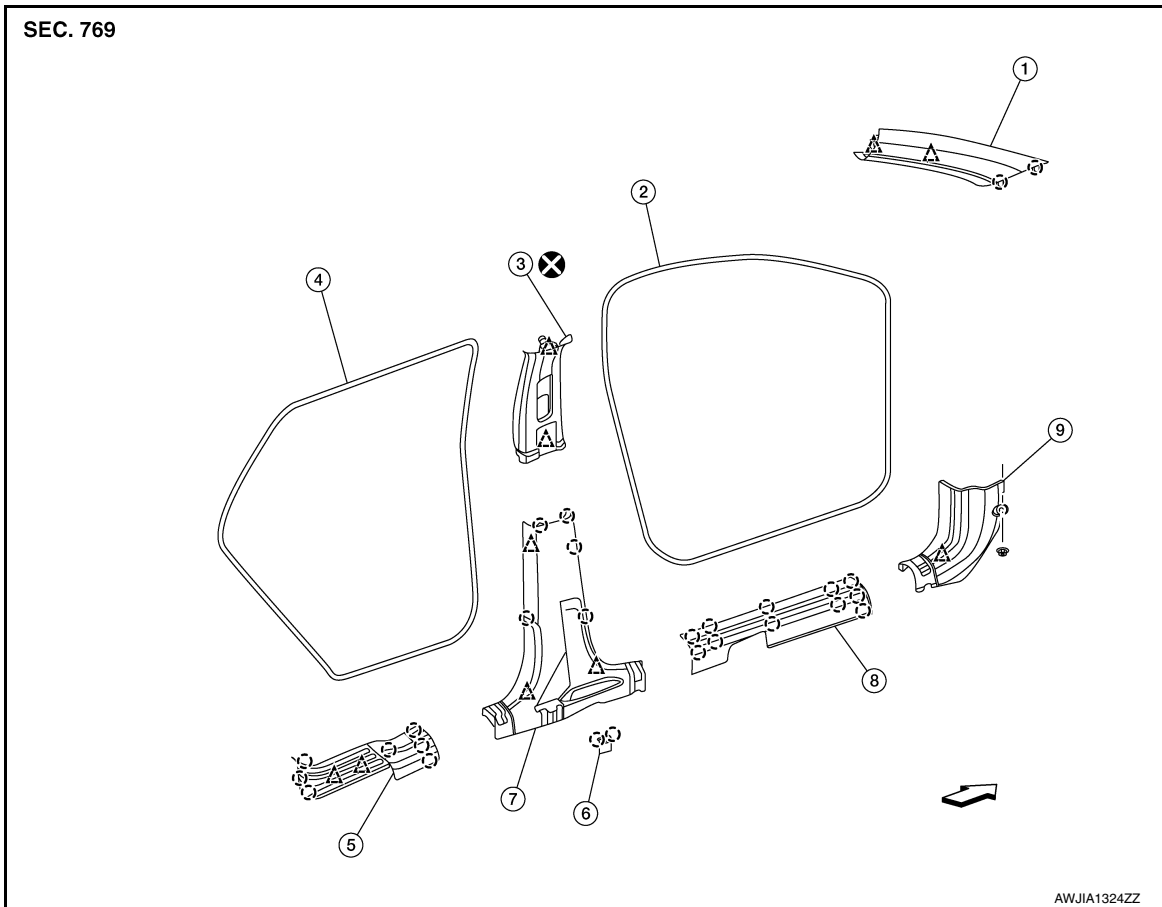

- | | | |
|---------------------------------|-------------------------|---------------------------------|
| 1. Front pillar finisher | 2. Front body side welt | 3. Center pillar upper finisher |
| 4. Rear body side welt | 5. Rear kicking plate | 6. Seat belt cover |
| 7. Center pillar lower finisher | 8. Front kicking plate | 9. Dash side finisher |
- Pawl △ Clip ⇐ Front

FRONT PILLAR FINISHER

FRONT PILLAR FINISHER : Removal and Installation

INFOID:000000012424600

REMOVAL

1. Partially remove front door welt (front edge).

BODY SIDE TRIM

< REMOVAL AND INSTALLATION >

2. Release the front pillar finisher pawls using a suitable tool.



3. Cut and discard front pillar finisher tether clip (A).

CAUTION:

Do not reuse tether clip. Replace with new part after removal.

4. Remove the remaining piece of tether clips (A) using a suitable tool and remove front pillar finisher.

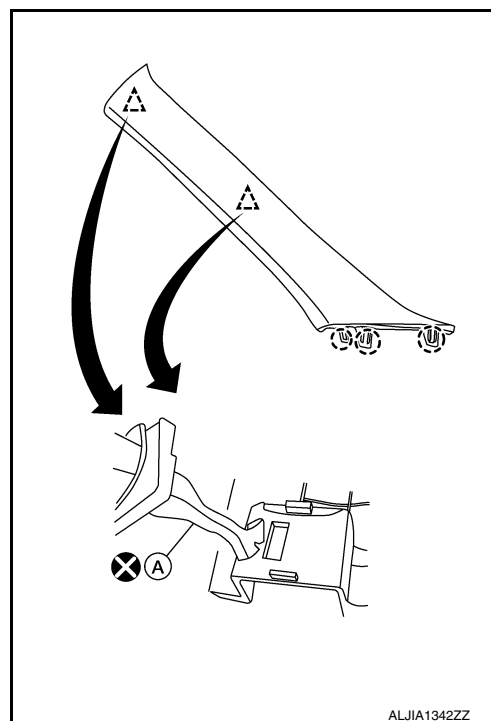

INSTALLATION

Installation is in the reverse order of removal.

CAUTION:

- Do not reuse tether clip. Replace with new part for installation.
- Make sure that the location of the airbag and tether clip do not block body panel holes before installing front pillar finisher.
- Make sure to install tether clip to front pillar finisher by inserting clip end and rotating 90 degrees in either direction, before installing front pillar finisher.
- When installing tether clip to front pillar finisher, be sure to install by aligning to the cutout.
- Front pillar finisher is re-usable.
- New tether clip should be used from service parts, ordered separately.

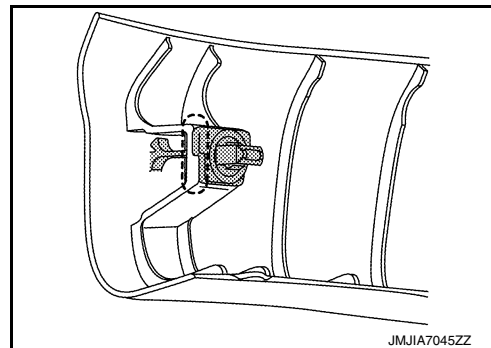

- When installing front pillar finisher, check that tether clip and pawls are securely placed into correct body panel holes.

CENTER PILLAR UPPER FINISHER

CENTER PILLAR UPPER FINISHER : Removal and Installation

INFOID:000000012424601

REMOVAL

1. Remove center pillar lower finisher. Refer to [INT-22. "CENTER PILLAR LOWER FINISHER : Removal and Installation"](#).

BODY SIDE TRIM

< REMOVAL AND INSTALLATION >

2. Release pawls, using a suitable tool and remove the seat belt height adjuster finisher (1).

○: Pawl

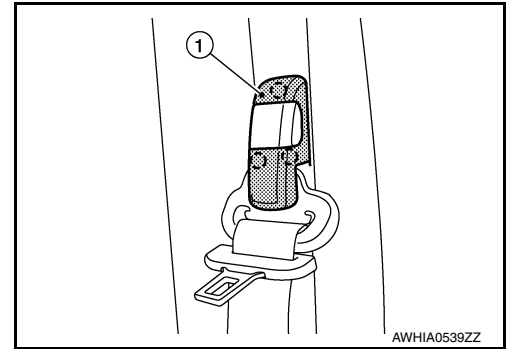

3. Remove front D-ring anchor bolt.

CAUTION:

Before removing D-ring anchor bolt note the positions of washers and spacers for correct installation.

4. Release center pillar upper finisher clips using a suitable tool as shown.
5. Release center pillar upper finisher (1) clips using a suitable tool and remove.

△: Clip

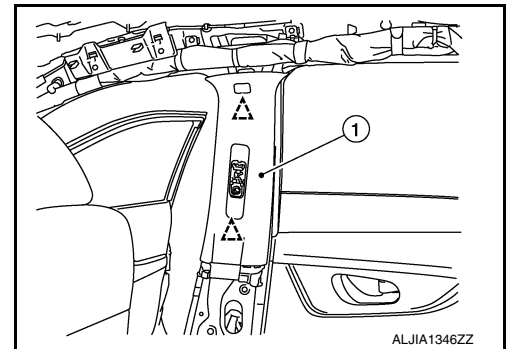

CAUTION:

- Do not reuse center pillar upper finisher.
- Do not bend the sheet metal when removing the center pillar upper finisher from the sheet metal.
- When releasing molded in clip, follow the steps as shown to prevent finisher or clip damage.

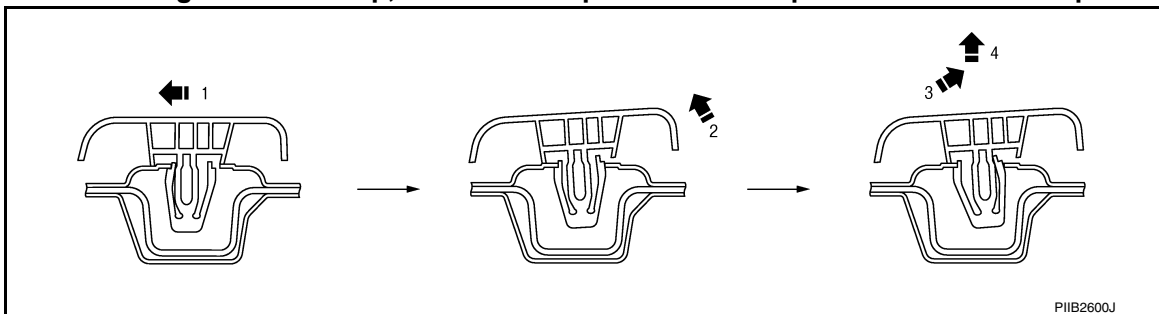

INSTALLATION

Installation is in the reverse order of removal.

CAUTION:

- Do not reuse center pillar upper finisher. Replace with new part for installation.
- Visually check sheet metal around clip and pawl locations to confirm no deformation from removal of center pillar upper finisher. Repair sheet metal if necessary.
- When installing center pillar upper finisher, check that the clips are securely placed in body panel holes.

CENTER PILLAR LOWER FINISHER

CENTER PILLAR LOWER FINISHER : Removal and Installation

INFOID:000000012424602

REMOVAL

1. Move front seat to the full forward position.

BODY SIDE TRIM

< REMOVAL AND INSTALLATION >

2. Remove front kicking plate. Refer to [INT-23. "KICKING PLATE : Removal and Installation - Front Kicking Plate"](#).
3. Partially remove the front door welt.
4. Remove rear kicking plate. Refer to [INT-24. "KICKING PLATE : Removal and Installation - Rear Kicking Plate"](#).
5. Partially remove the rear door welt.
6. Release center pillar lower finisher clips and pawls using a suitable tool, then remove the center pillar lower finisher (1).

- △: Clip
- : Pawl

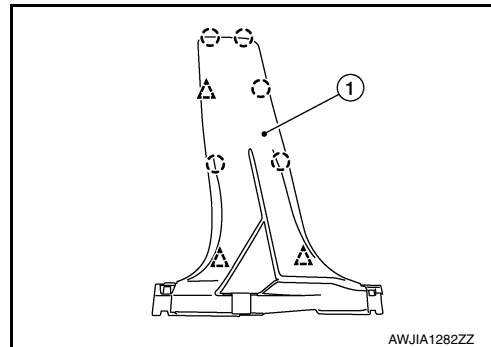

INSTALLATION

Installation is in the reverse order of removal.

CAUTION:

- Visually check the clips for deformation and damage during installation. Replace with new ones if necessary.
- When installing center pillar lower finisher, check that clips and pawls are securely placed in body panel holes.

BODY SIDE WELT

BODY SIDE WELT : Removal and Installation - Front Door Welt

INFOID:000000012424603

REMOVAL

1. Remove the front kicking plate. Refer to [INT-23. "KICKING PLATE : Removal and Installation - Front Kicking Plate"](#).
2. Remove the front body side welt.

INSTALLATION

Installation is in the reverse order of removal.

BODY SIDE WELT : Removal and Installation - Rear Door Welt

INFOID:000000012424604

REMOVAL

1. Remove the rear kicking plate. Refer to [INT-24. "KICKING PLATE : Removal and Installation - Rear Kicking Plate"](#).
2. Remove the rear body side welt.

INSTALLATION

Installation is in the reverse order of removal.

KICKING PLATE

KICKING PLATE : Removal and Installation - Front Kicking Plate

INFOID:000000012424605

REMOVAL

BODY SIDE TRIM

< REMOVAL AND INSTALLATION >

1. Release the front and rear pawls by rotating the front kicking plate.
○: Pawl
⇐: Front
2. Lift front edge of front kicking plate and release the remaining pawls using suitable tool (A) and remove.

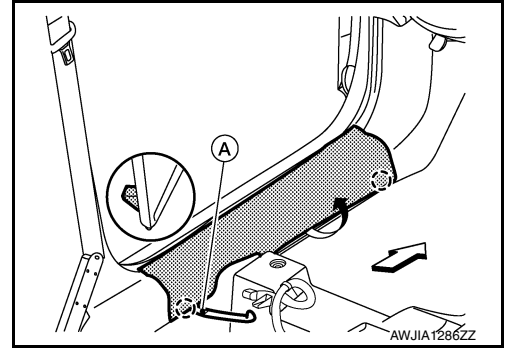

INSTALLATION

Installation is in the reverse order of removal.

CAUTION:

- Visually check the clips and pawls for deformation and damage during installation. Replace with new ones if necessary.
- When installing front kicking plate, check that the floor trim does not cover harness protector slots.
- When installing front kicking plate, check that the clips and pawls are securely placed in body panel holes.

KICKING PLATE : Removal and Installation - Rear Kicking Plate

INFOID:0000000012424606

REMOVAL

1. Release front inside pawl of rear kicking plate as shown, then lift front end of rear kicking plate to release pawls and remove.
○: Pawl
⇐: Front

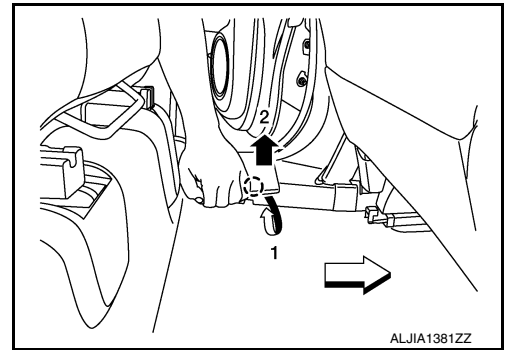

INSTALLATION

Installation is in the reverse order of removal.

CAUTION:

- Visually check the clips and pawls for deformation and damage during installation. Replace with new ones if necessary.
- When installing rear kicking plate, check that the clips and pawls are securely placed in body panel holes.

DASH SIDE FINISHER

DASH SIDE FINISHER : Removal and Installation

INFOID:0000000012424607

REMOVAL

1. Remove front kicking plate. Refer to [INT-23, "KICKING PLATE : Removal and Installation - Front Kicking Plate"](#).
2. Partially remove the front door welt.

BODY SIDE TRIM

< REMOVAL AND INSTALLATION >

3. Remove nut (A) then insert suitable tool (B) to release clip, then remove dash side finisher (1).

△: Clip

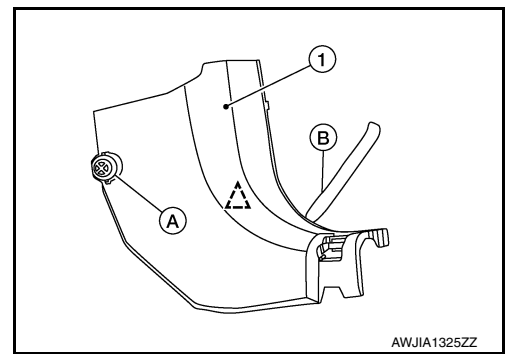

INSTALLATION

Installation is in the reverse order of removal.

CAUTION:

- Visually check the clips for deformation and damage during installation. Replace with new ones if necessary.
- When installing dash side finisher, make sure insulation does not cover stud bolt.
- When installing dash side finisher, check that the clips are securely placed in body panel holes.

A
B
C
D
E
F
G
H
I
INT
K
L
M
N
O
P

FLOOR TRIM

< REMOVAL AND INSTALLATION >

FLOOR TRIM

Exploded View

INFOID:000000012424608

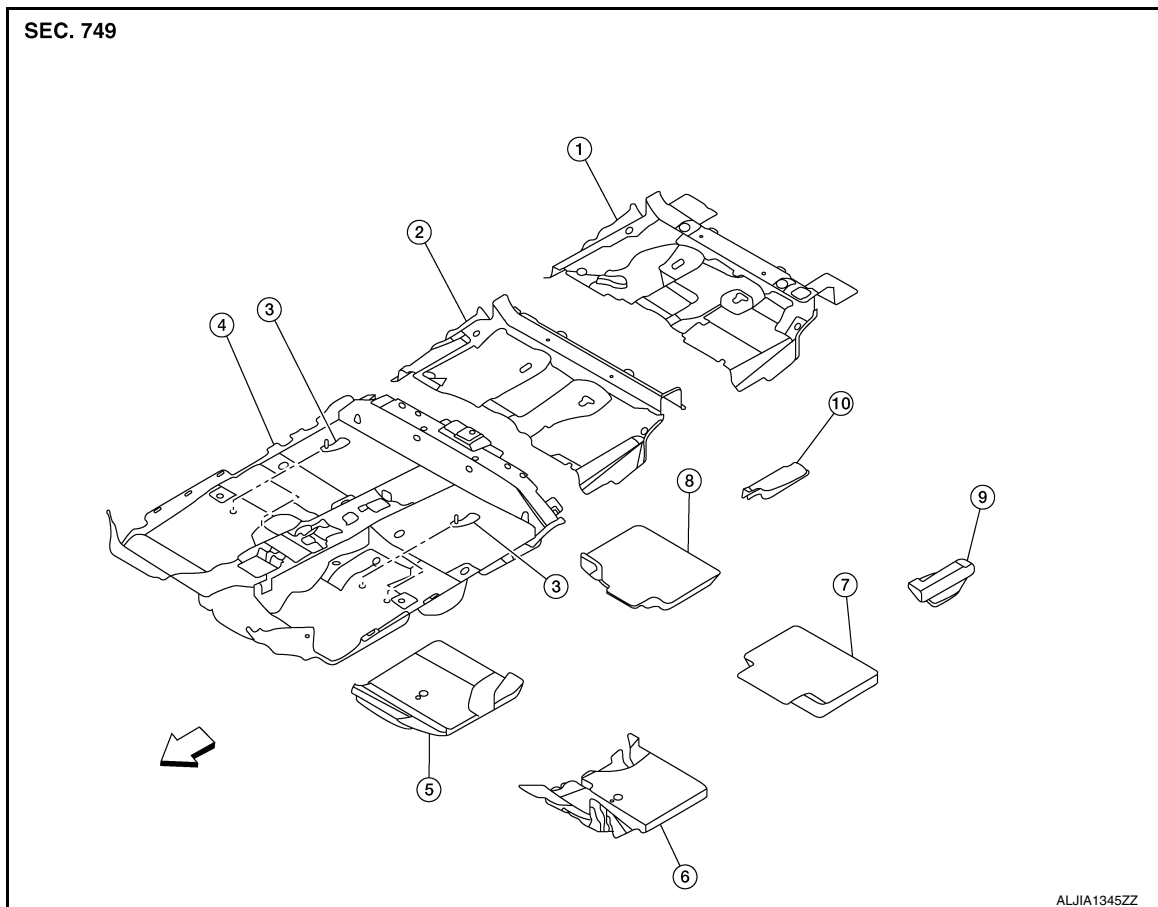

- | | | |
|--|---|--------------------------------|
| 1. Rear floor trim (with third row seat) | 2. Rear floor trim (without third row seat) | 3. Floor trim hook |
| 4. Front floor trim | 5. Front floor spacer (RH) | 6. Front floor spacer (LH) |
| 7. Rear floor spacer (LH) | 8. Rear floor spacer (RH) | 9. Third row floor spacer (LH) |
| 10. Third row floor spacer (RH) | ↔ Front | |

Removal and Installation

INFOID:000000012424609

CAUTION:

Before servicing, turn the ignition switch off, disconnect both battery cables and wait at least three minutes.

REMOVAL - Front Floor Trim

1. Disconnect the negative and positive battery terminals, then wait at least three minutes. Refer to [PG-80, "Removal and Installation \(Battery\)"](#).
2. Remove front door welts (LH/RH). Refer to [INT-23, "BODY SIDE WELT : Removal and Installation - Front Door Welt"](#).
3. Remove rear door welts (LH/RH). Refer to [INT-23, "BODY SIDE WELT : Removal and Installation - Rear Door Welt"](#).
4. Remove driver and passenger seat (LH/RH). Refer to [SE-32, "DRIVER SIDE : Removal and Installation"](#).
5. Remove second row seats. Refer to [SE-39, "Removal and Installation"](#).
6. Disconnect harness connectors from seatbelt pretensioners.
7. Remove dash side finisher (LH/RH). Refer to [INT-24, "DASH SIDE FINISHER : Removal and Installation"](#).

FLOOR TRIM

< REMOVAL AND INSTALLATION >

8. Remove shift selector. Refer to [TM-193, "Removal and Installation"](#).
9. Remove center pillar upper finisher (LH/RH). Refer to [INT-21, "CENTER PILLAR UPPER FINISHER : Removal and Installation"](#).
10. Remove the front floor connecting ducts (LH/RH). Refer to [VTL-10, "FRONT FLOOR DUCT : Removal and Installation - Front Floor Connecting Duct"](#).
11. Disconnect front parking brake cable from rear parking brake cable and remove bolts from parking brake cable hold down. Refer to [PB-7, "Exploded View"](#).
12. Disconnect heating and cooling unit assembly drain hose from floor.
13. Release clips (A) using a suitable tool and remove steering joint floor cover (1).

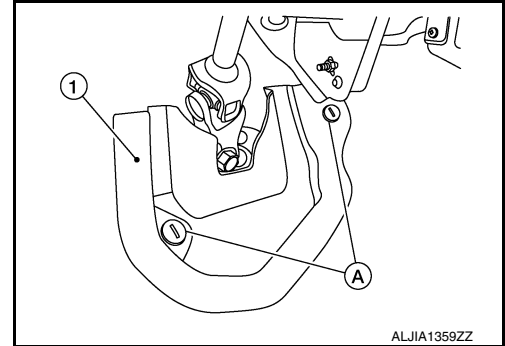

14. Remove floor trim hooks (1) using a suitable tool (A) and front floor trim.

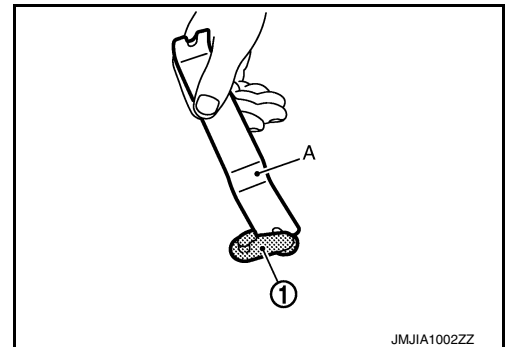

15. Remove the following parts (if necessary).
 - Front floor spacer (LH/RH)
 - Rear floor spacer (LH/RH)

INSTALLATION

Installation is in the reverse order of removal.

REMOVAL - Rear Floor Trim

CAUTION:

Before servicing, turn the ignition switch off, disconnect both battery cables and wait at least three minutes.

1. Disconnect the negative and positive battery terminals, then wait at least three minutes. Refer to [PG-80, "Removal and Installation \(Battery\)"](#).
2. Partially remove front door welts (LH/RH). Refer to [INT-23, "BODY SIDE WELT : Removal and Installation - Front Door Welt"](#).
3. Partially remove rear door welts (LH/RH). Refer to [INT-23, "BODY SIDE WELT : Removal and Installation - Rear Door Welt"](#).
4. Remove second row seats. Refer to [SE-39, "Removal and Installation"](#).
5. Remove seat belt lower anchor bolt (LH/RH).

CAUTION:

Before removing the seat belt lower anchor bolt, note the positions of washers and spacers for correct installation.

6. Remove luggage side lower finisher (LH/RH). Refer to [INT-34, "LUGGAGE SIDE LOWER FINISHER : Removal and Installation - With Third Row Seat"](#).

FLOOR TRIM

< REMOVAL AND INSTALLATION >

7. Remove third row seats (if equipped). Refer to [SE-43. "Removal and Installation"](#).
8. Remove rear floor trim.

INSTALLATION

Installation is in the reverse order of removal.

HEADLINING

< REMOVAL AND INSTALLATION >

HEADLINING

Exploded View

INFOID:000000012424610

WITHOUT MOONROOF

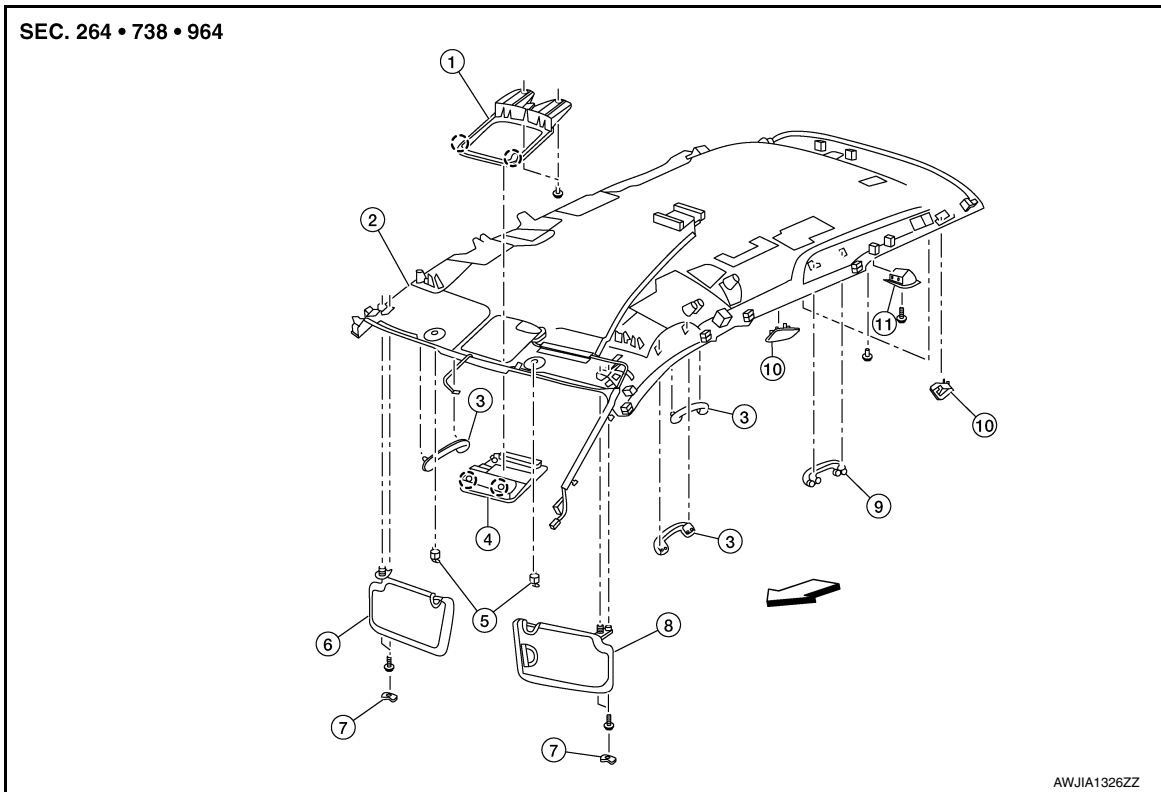

- | | | |
|------------------------------|---|--------------------------------------|
| 1. Map lamp assembly bracket | 2. Headlining | 3. Assist grip (without coat hanger) |
| 4. Map lamp assembly | 5. Sun visor holder (LH/RH) | 6. Sun visor (RH) |
| 7. Sun visor cover | 8. Sun visor (LH) | 9. Assist grip (with coat hanger) |
| 10. Headlining cover | 11. Top tether strap child restraint finisher | ← Front |
- Pawl

A
B
C
D
E
F
G
H
I

INT

K
L
M
N
O
P

HEADLINING

< REMOVAL AND INSTALLATION >

WITH MOONROOF

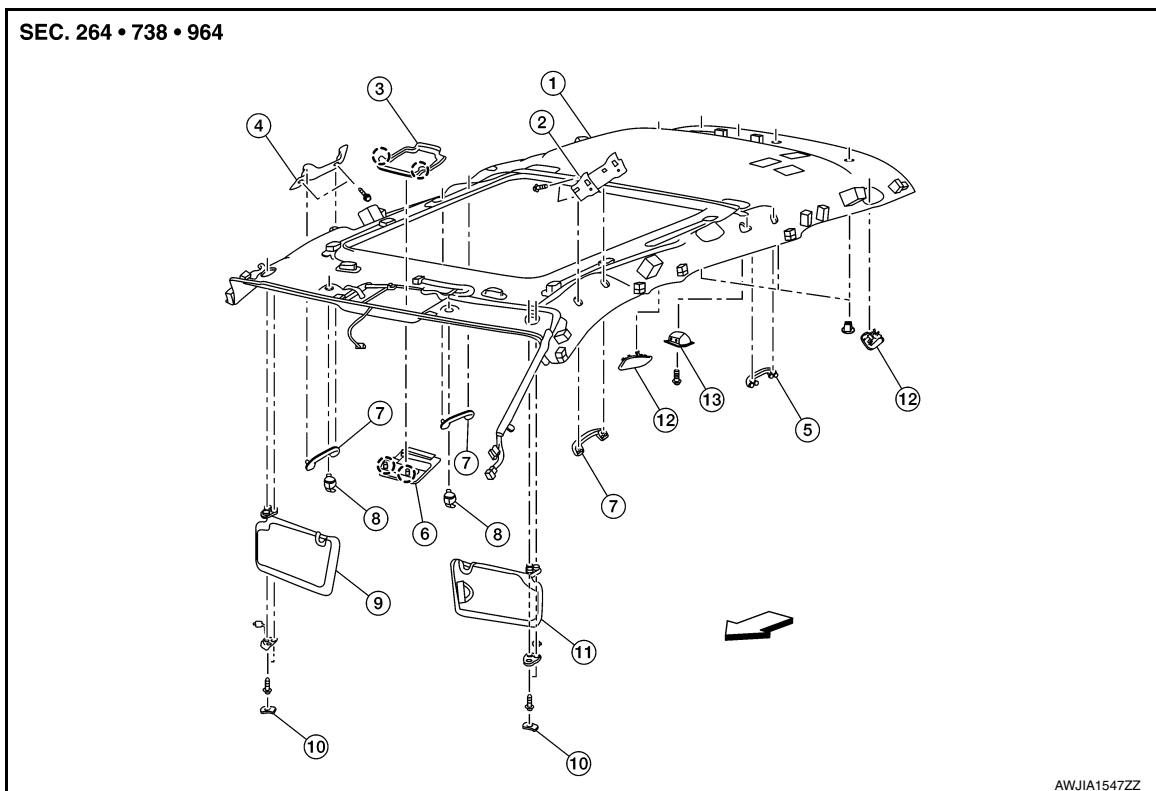

- | | | |
|---|-----------------------------------|------------------------------|
| 1. Headlining | 2. Front assist grip bracket (LH) | 3. Map lamp assembly bracket |
| 4. Front assist grip bracket (RH) | 5. Assist grip (with coat hanger) | 6. Map lamp assembly |
| 7. Assist grip (without coat hanger) | 8. Sun visor holder (LH/RH) | 9. Sun visor (RH) |
| 10. Sun visor cover (LH/RH) | 11. Sun visor (LH) | 12. Headlining cover |
| 13. Top tether strap child restraint finisher | ◀ Front | ○ Pawl |

Removal and Installation

INFOID:000000012424611

REMOVAL

WARNING:

Before servicing the SRS, turn ignition switch OFF, disconnect both battery terminals then wait at least three minutes.

1. Disconnect negative and positive battery terminals, then wait at least three minutes. Refer to [PG-80, "Removal and Installation \(Battery\)"](#).
2. Remove front pillar finisher (LH/RH). Refer to [INT-20, "FRONT PILLAR FINISHER : Removal and Installation"](#).
3. Remove center pillar upper finisher (LH/RH). Refer to [INT-21, "CENTER PILLAR UPPER FINISHER : Removal and Installation"](#).
4. Remove luggage side upper finisher (LH/RH). Refer to [INT-36, "LUGGAGE SIDE UPPER FINISHER : Removal and Installation"](#).
5. Remove map lamp assembly. Refer to [INL-55, "Removal and Installation"](#).
6. Disconnect personal lamp and microphone harness connectors.

HEADLINING

< REMOVAL AND INSTALLATION >

7. Remove sun visor cover (LH/RH) (1) by inserting a suitable tool (A) as shown.

○: Pawl

CAUTION:

Do not damage headlining or sun visor cover surface.

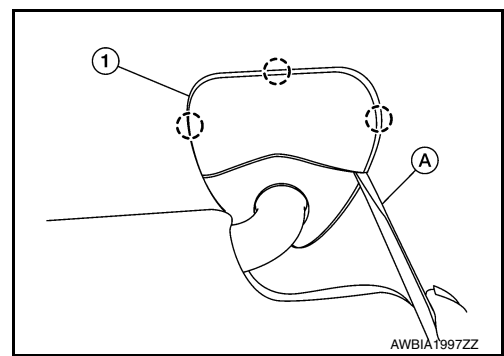

8. Remove sun visor bolts (A) (LH/RH), then disconnect harness connectors and remove .

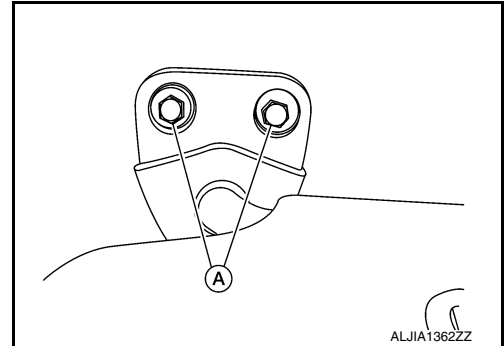

9. Insert a suitable tool (A) at approximately a 30 degree angle into the sun visor holder notch on the front of the sun visor holder (1). Press in to release the locking tab (B). While holding in locking tab (B), turn the sun visor holder (1) 90 degrees to release it from the headliner.

- If the sun visor holder (1) does not fully rotate, make sure that the suitable tool (A) is pressing in on the locking tab (B) and is not positioned under locking tab (B). Reinsert the suitable tool (A) as necessary to release the locking tab (B).

- ←: Front

CAUTION:

Do not force the sun visor holder when removing as the locking tab may be damaged if the suitable tool is not positioned correctly.

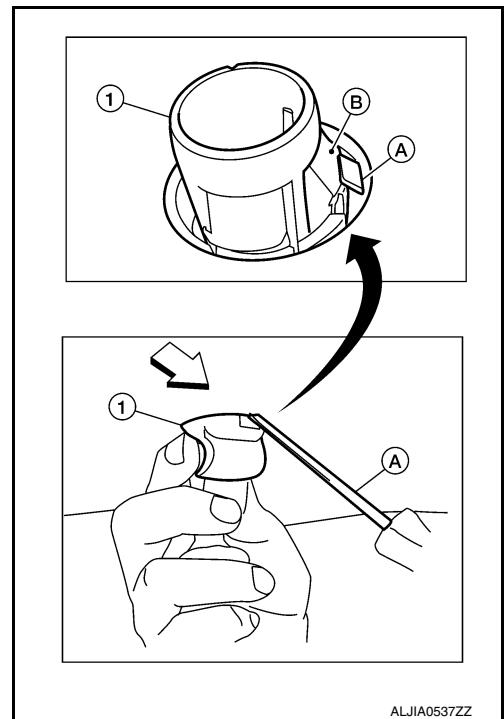

10. Remove front assist grip (LH/RH) and rear assist grip (LH/RH).
- a. Remove assist grip cap (3).
 - b. Release clip (1) and remove assist grip (2).

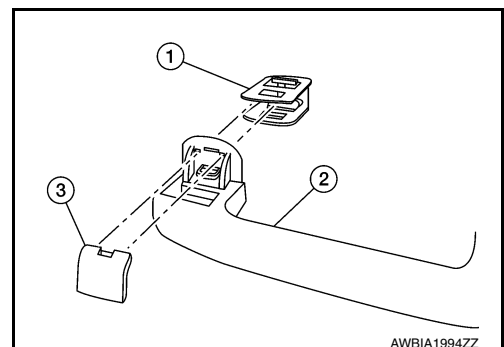

HEADLINING

< REMOVAL AND INSTALLATION >

11. Insert suitable tool from front, release pawls then pull headlining cover (LH/RH) (1) forward and outward to remove.

○: Pawl
⇐ Front

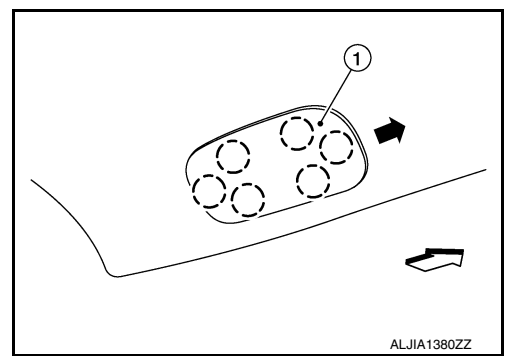

12. Insert two fingers through hole on headlining.

(A) :Tether

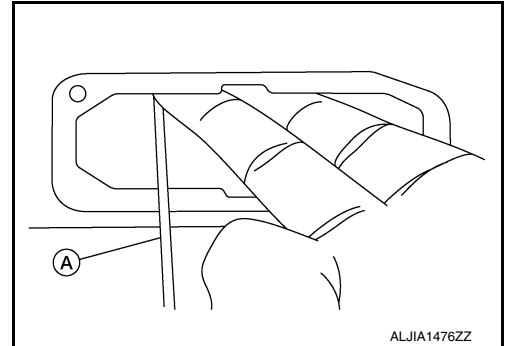

13. Release tether (A) from hook (B) and remove.

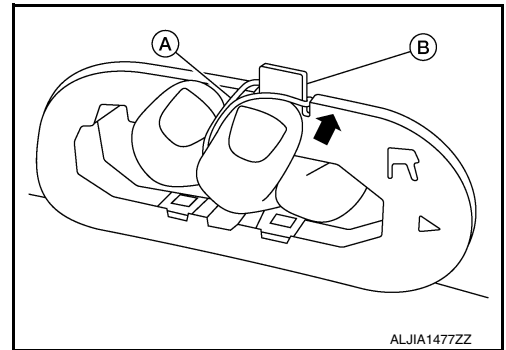

14. Remove screw (A) then release pawls using a suitable tool and remove child tether finisher (1).

○: Pawl

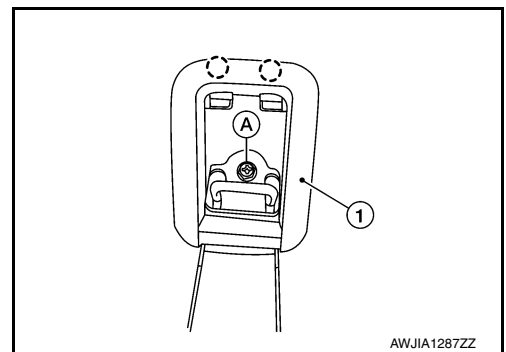

15. Release headlining clips at rear and remove headlining through the back door.

CAUTION:

- When removing headlining, two workers are required.
- Do not bend headlining when removing.
- Be careful not to scratch or damage any part of the body while removing the headlining.

INSTALLATION

Installation is in the reverse order of removal.

CAUTION:

- Install sun-visor holder (LH/RH) and headlining clips at rear for positioning.
- Do not to bend the headlining when installing.

LUGGAGE TRIM

< REMOVAL AND INSTALLATION >

LUGGAGE TRIM

Exploded View

INFOID:000000012424612

WITH THIRD ROW SEAT

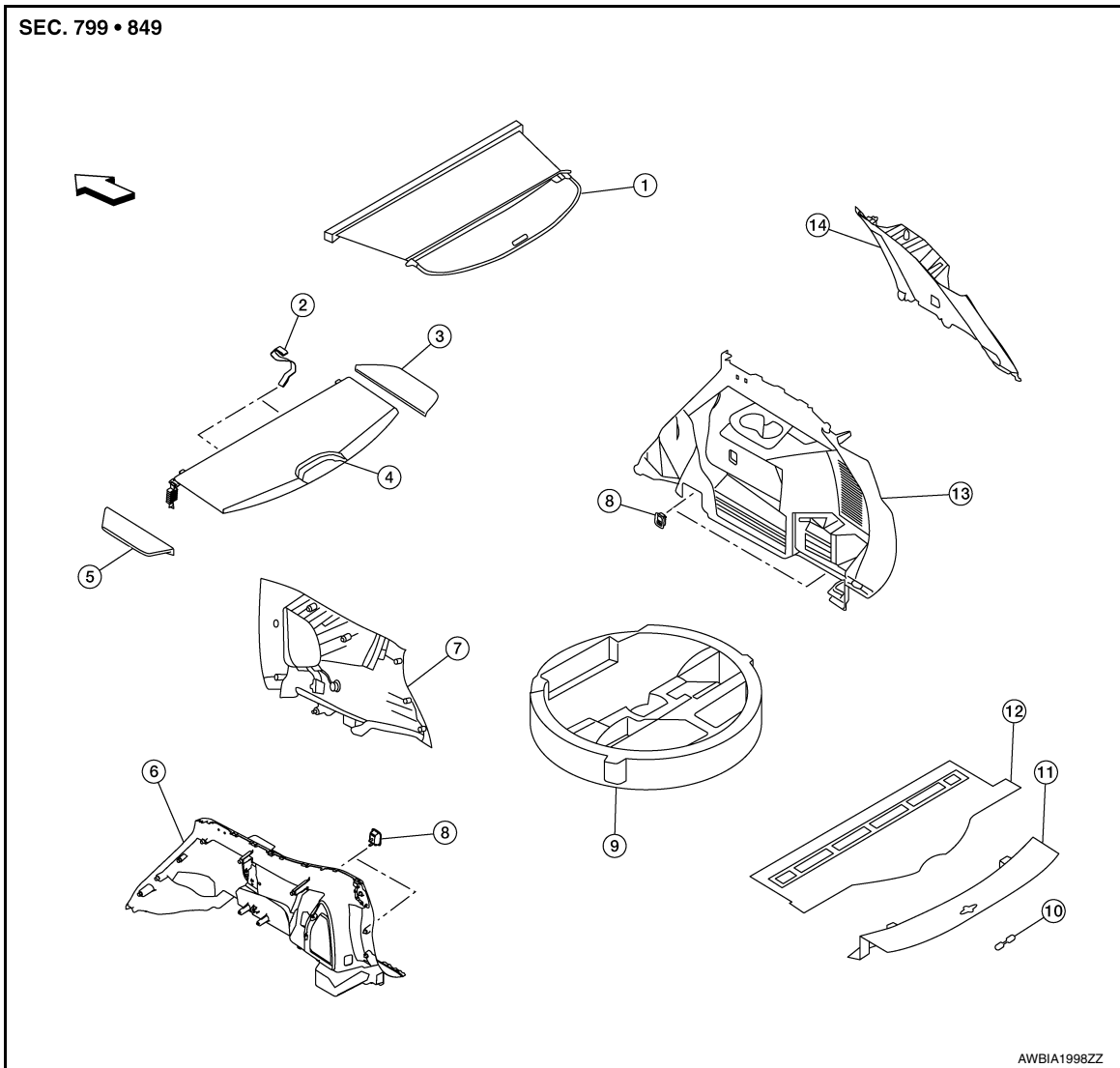

- | | | |
|--------------------------------------|--------------------------------------|-------------------------------------|
| 1. Tonneau cover (if equipped) | 2. Strap (LH/RH) | 3. Luggage floor finisher (RH) |
| 4. Luggage floor center finisher | 5. Luggage floor finisher (LH) | 6. Luggage side lower finisher (LH) |
| 7. Luggage side upper finisher (LH) | 8. Hooks (LH/RH) | 9. Luggage storage box |
| 10. Luggage rear plate finisher | 11. Luggage rear plate | 12. Luggage floor trim |
| 13. Luggage side lower finisher (RH) | 14. Luggage side upper finisher (RH) | ⇐ Front |

A
B
C
D
E
F
G
H
I
INT
K
L
M
N
O
P

LUGGAGE TRIM

< REMOVAL AND INSTALLATION >

WITHOUT THIRD ROW SEAT

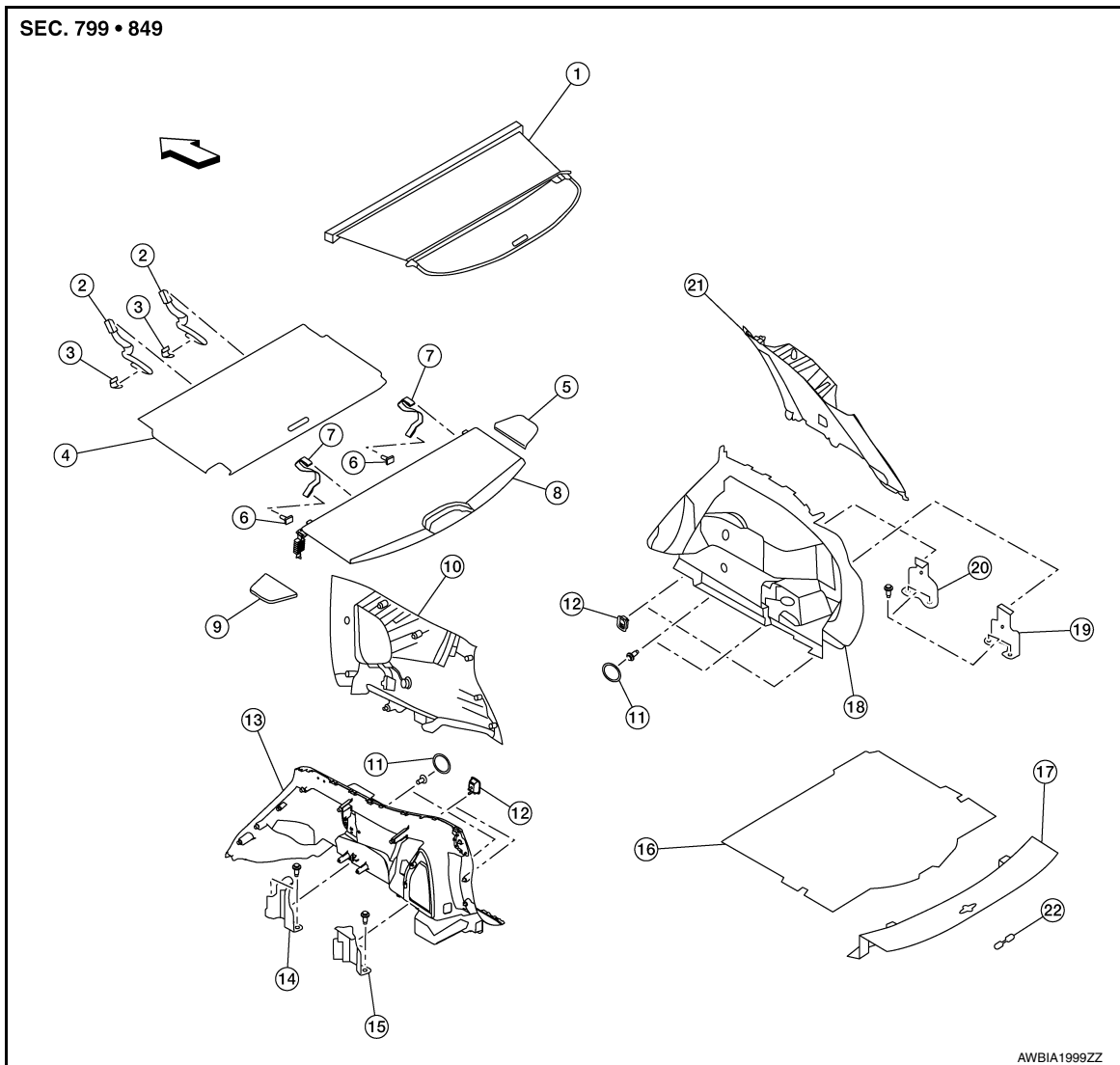

- | | | |
|---|--|---|
| 1. Tonneau cover (if equipped) | 2. Front strap (LH/RH) | 3. Front strap hook (LH/RH) |
| 4. Front luggage floor finisher | 5. Luggage floor finisher (RH) | 6. Rear strap hook (LH/RH) |
| 7. Rear strap (LH/RH) | 8. Rear luggage floor finisher | 9. Luggage floor finisher (LH) |
| 10. Luggage side upper finisher (LH) | 11. Bolt covers (LH/RH) | 12. Hooks (LH/RH) |
| 13. Luggage side lower finisher (LH) | 14. Luggage side lower finisher front bracket (LH) | 15. Luggage side lower finisher rear bracket (LH) |
| 16. Luggage floor trim | 17. Luggage rear plate | 18. Luggage side lower finisher (RH) |
| 19. Rear luggage side lower finisher bracket (RH) | 20. Front luggage side lower finisher bracket (RH) | 21. Luggage side upper finisher (RH) |
| 22. Luggage rear plate finisher | ↔ Front | |

LUGGAGE SIDE LOWER FINISHER

LUGGAGE SIDE LOWER FINISHER : Removal and Installation - With Third Row Seat

INFOID:000000012424613

REMOVAL

1. Release straps and remove luggage floor finisher front and rear.
2. Remove luggage rear plate. Refer to [INT-37, "LUGGAGE REAR PLATE : Removal and Installation"](#).
3. Partially remove back door weatherstrip.

LUGGAGE TRIM

< REMOVAL AND INSTALLATION >

4. Remove the rear kicking plate. Refer to [INT-24. "KICKING PLATE : Removal and Installation - Rear Kicking Plate"](#).
5. Partially remove the rear door welt.
6. Fold third row seatback flat.
7. Remove the luggage side lower finisher hook bolts and hooks.
8. Remove the luggage side lower finisher bolt covers (A) then remove bolts.

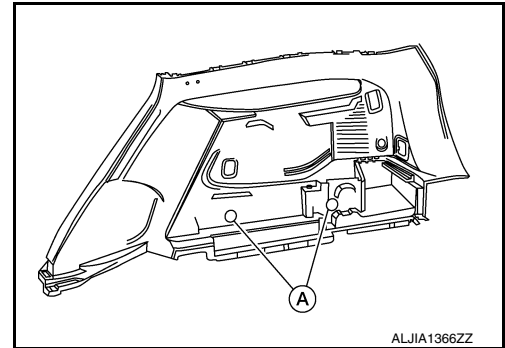

9. Release luggage side lower finisher (1) clips and pawls.

△: Clip
○: Pawl

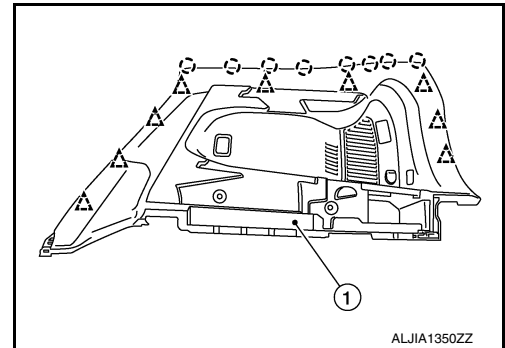

10. Disconnect the harness connector from power socket (RH only) and luggage room lamp (RH only) and remove.

INSTALLATION

Installation is in the reverse order of removal.

CAUTION:

- Visually check the clips and pawls for deformation and damage during installation. Replace with new ones if necessary.
- When installing luggage side lower finisher, check that clips and pawls are securely placed in body panel holes.

LUGGAGE SIDE LOWER FINISHER : Removal and Installation - Without Third Row Seat

INFOID:000000012424614

REMOVAL

1. Release straps and remove luggage floor finisher front and rear.
2. Remove luggage rear plate. Refer to [INT-37. "LUGGAGE REAR PLATE : Removal and Installation"](#).
3. Partially remove back door weatherstrip.
4. Remove the rear kicking plate. Refer to [INT-24. "KICKING PLATE : Removal and Installation - Rear Kicking Plate"](#).
5. Partially remove rear door welt.
6. Remove the luggage side lower finisher hook bolts and hooks.

LUGGAGE TRIM

< REMOVAL AND INSTALLATION >

7. Release luggage side lower finisher (1) clips and pawls.

△: Clip
○: Pawl

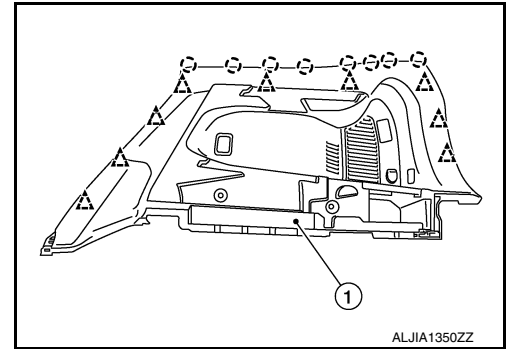

8. Disconnect the harness connector from power socket (RH only) and luggage room lamp (RH only) and remove.

INSTALLATION

Installation is in the reverse order of removal.

CAUTION:

- Visually check the clips and pawls for deformation and damage during installation. Replace with new ones if necessary.
- When installing luggage side lower finisher, check that clips and pawls are securely placed in body panel holes.

LUGGAGE SIDE UPPER FINISHER

LUGGAGE SIDE UPPER FINISHER : Removal and Installation

INFOID:0000000012424615

REMOVAL

1. Remove luggage side lower finisher. Refer to [INT-34, "LUGGAGE SIDE LOWER FINISHER : Removal and Installation - With Third Row Seat"](#) (with third row seat) or [INT-35, "LUGGAGE SIDE LOWER FINISHER : Removal and Installation - Without Third Row Seat"](#) (without third row seat).
2. Remove rear and third row seatbelt d-ring anchor bolt covers, then remove rear and third row seatbelt d-ring anchor bolts (A and B).

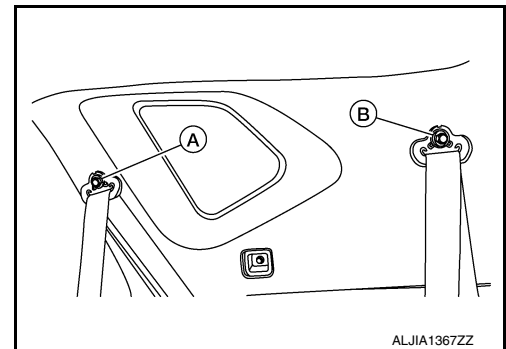

3. Remove luggage side upper finisher bolt (A).

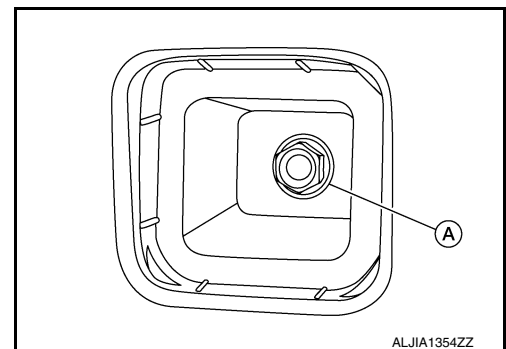

LUGGAGE TRIM

< REMOVAL AND INSTALLATION >

4. Release clips, then remove luggage side upper finisher (1).

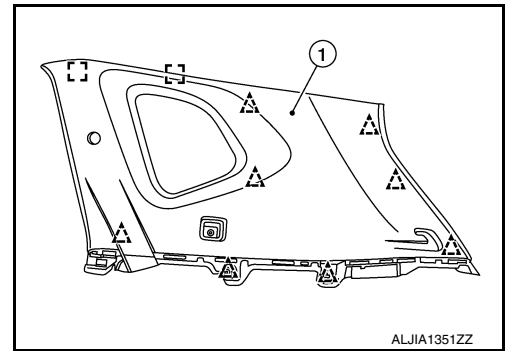

INSTALLATION

Installation is in the reverse order of removal.

CAUTION:

- Visually check the clips for deformation and damage during installation. Replace with new ones if necessary.
- When installing luggage side upper finisher, check that clips are securely placed in body panel holes.

LUGGAGE REAR PLATE

LUGGAGE REAR PLATE : Removal and Installation

INFOID:0000000012424616

REMOVAL

1. Remove the luggage floor cover.
2. Release the luggage rear plate front clips (A) using a suitable tool.

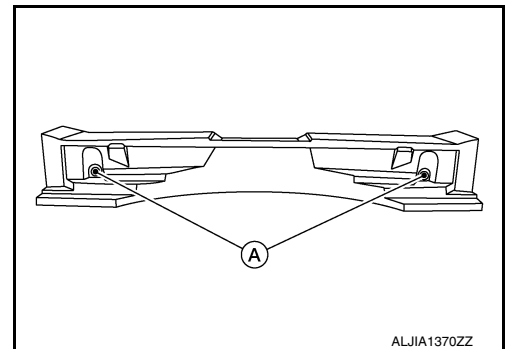

3. Remove the striker finisher.
4. Release clips and pawls using a suitable tool and remove luggage rear plate (1).

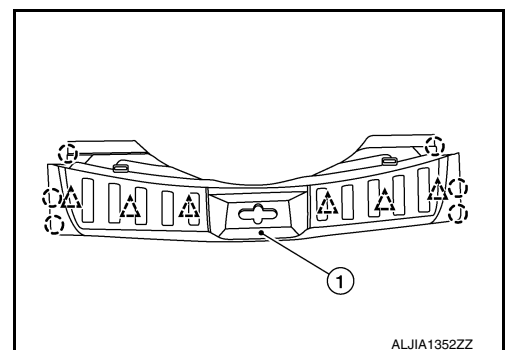
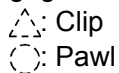

INSTALLATION

Installation is in the reverse order of removal.

CAUTION:

- Visually check the clips and pawls for deformation and damage during installation. Replace with new ones if necessary.
- When installing luggage rear plate, check that clips and pawls are securely placed in body panel holes.

A
B
C
D
E
F
G
H
I
INT
K
L
M
N
O
P

BACK DOOR FINISHER

< REMOVAL AND INSTALLATION >

BACK DOOR FINISHER

Exploded View

INFOID:000000012424617

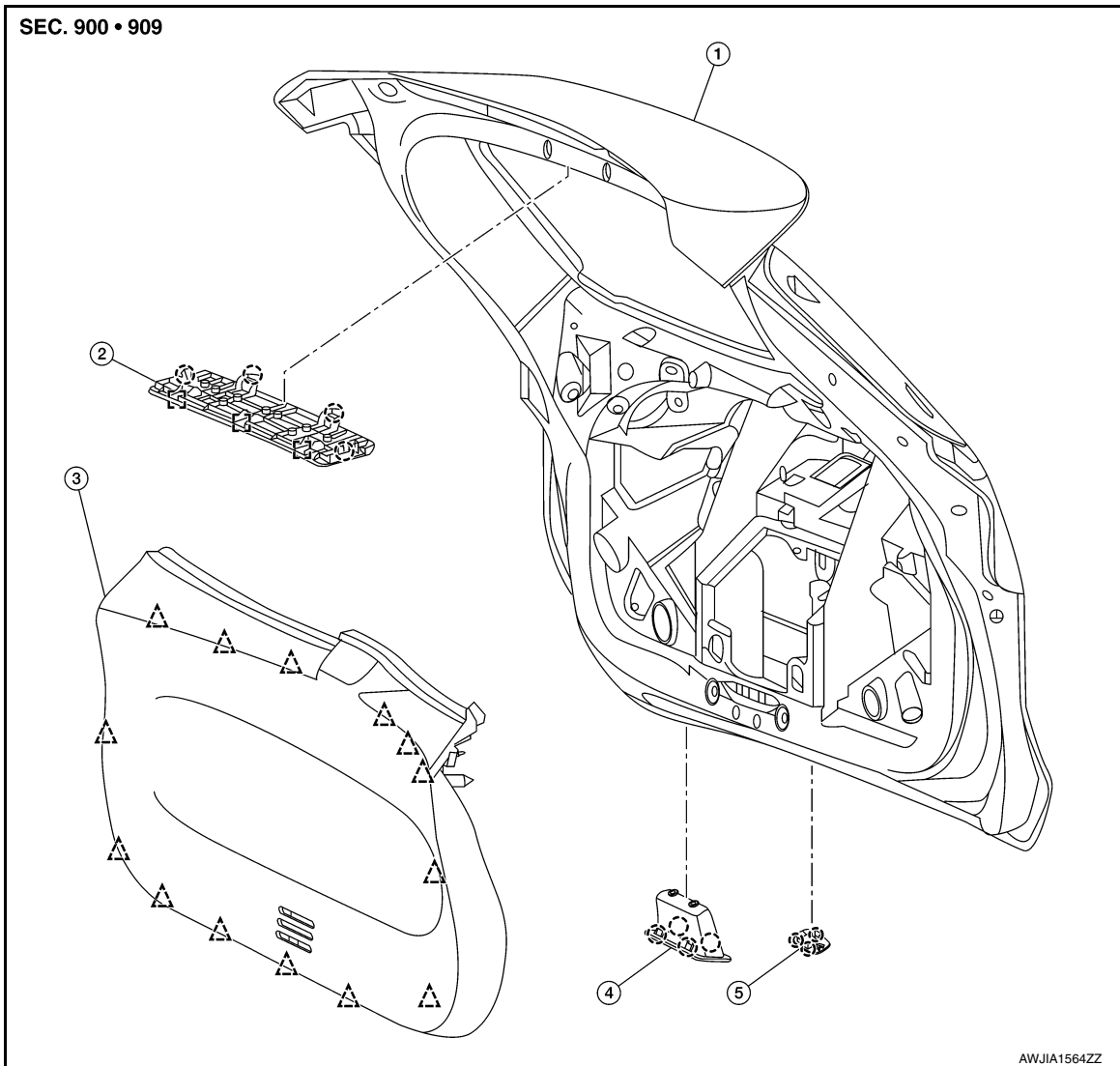

- | | | |
|--------------------------|---|-----------------------|
| 1. Back door | 2. Access cover | 3. Back door finisher |
| 4. Back door pull handle | 5. Mask (without automatic back door close switch) or automatic back door close switch finisher (with automatic back door close switch) | ○ Pawl |
| △ Clip | □ Metal clip | |

Removal and Installation

INFOID:000000012424618

REMOVAL

BACK DOOR FINISHER

< REMOVAL AND INSTALLATION >

1. Using a suitable tool (A) release upper LH most clip, then release remaining clips by gently pulling down on back door finisher (1).
- △ : Clip
2. Remove back door finisher.

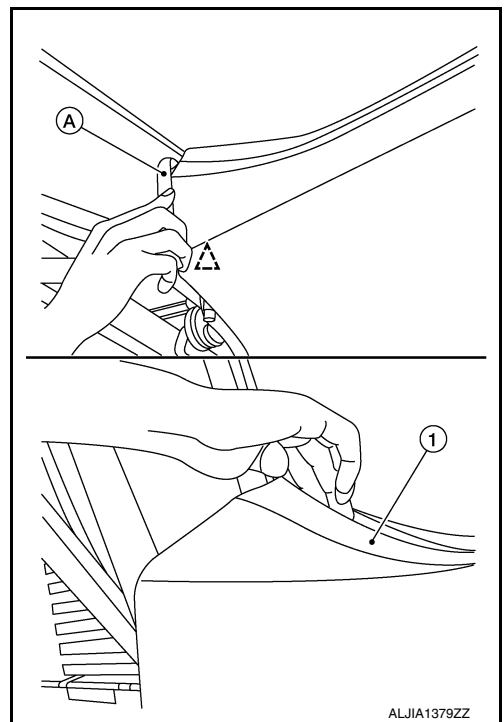

INSTALLATION

Installation is in the reverse order of removal.

CAUTION:

When installing back door finisher, check that clips are securely placed in door panel holes.

A
B
C
D
E
F
G
H
I
K
L
M
N
O
P

INT