

STEERING SYSTEM

SECTION **ST**

GI

MA

EM

LC

EF &
EC

CONTENTS

PRECAUTIONS AND PREPARATION	2	Inspection.....	12	FE
Precautions.....	2	MANUAL STEERING GEAR AND LINKAGE		
Special Service Tools.....	2	(Model R24N)	13	CL
Commercial Service Tools.....	4	Removal and Installation.....	13	
ON-VEHICLE SERVICE	5	Disassembly.....	14	
Checking Steering Wheel Play.....	5	Inspection.....	14	MT
Checking Neutral Position on Steering Wheel.....	5	Assembly and Adjustment.....	15	
Front Wheel Turning Angle.....	5	POWER STEERING GEAR AND LINKAGE (Model		
Checking Gear Housing Movement.....	5	PR24AC)	18	AT
Checking and Adjusting Drive Belts (For		Removal and Installation.....	18	
power steering).....	5	Disassembly.....	21	FA
Checking Fluid Level.....	6	Inspection.....	22	
Checking Fluid Leakage.....	6	Assembly.....	22	
Bleeding Hydraulic System.....	6	Adjustment.....	27	RA
Checking Steering Wheel Turning Force (For		POWER STEERING OIL PUMP	29	
power steering).....	7	Pre-disassembly Inspection.....	29	
Checking Hydraulic System.....	7	Disassembly.....	30	BR
STEERING WHEEL AND STEERING COLUMN	9	Inspection.....	30	
Removal (With air bag).....	9	Assembly.....	31	ST
Removal (Without air bag).....	10	SERVICE DATA AND SPECIFICATIONS (SDS)	32	
Installation.....	10	General Specifications.....	32	
Disassembly and Assembly.....	11	Inspection and Adjustment.....	32	BF

HA

EL

DX

PRECAUTIONS AND PREPARATION

Precautions

SUPPLEMENTAL RESTRAINT SYSTEM "AIR BAG"

The Supplemental Restraint System "Air Bag" helps to reduce the risk or severity of injury to the driver in a frontal collision. The Supplemental Restraint System consists of an air bag (located in the center of the steering wheel), sensors, a diagnosis unit, warning lamp, wiring harness and spiral cable. Information necessary to service the system safely is included in the **BF section** of this Service Manual.

WARNING:



- a. To avoid rendering the SRS inoperative, which could lead to personal injury or death in the event of a severe frontal collision, all maintenance must be performed by an authorized NISSAN dealer.
- b. Improper maintenance, including incorrect removal and installation of the SRS, can lead to personal injury caused by unintentional activation of the system.
- c. All SRS electrical wiring harnesses and connectors are covered with yellow outer insulation. Do not use electrical test equipment on any circuit related to the SRS "Air Bag".

STEERING SYSTEM

- The power steering gear and oil pump should be disassembled only when repairing an "oil leak". They should not be disassembled to repair any other steering defect, steering noise, etc.
- Before disassembly, thoroughly clean the outside of the unit.
- Disassembly should be done in a clean work area. It is important to prevent the internal parts from becoming contaminated by dirt or other foreign matter.
- When disassembling parts, be sure to place them in order in a parts rack so they can be put back in the unit in their proper positions.
- Use a nylon cloth or paper towel for wiping parts clean. Common shop rags can leave lint that might interfere with the operation.
- All parts should be carefully cleaned with a general purpose, non-flammable solvent before inspection or reassembly.
- Before assembly, apply a coat of recommended ATF* to hydraulic parts. Vaseline may be applied to O-rings and seals. Do not use any grease.
- Gaskets, seals and O-rings should be replaced. Care should be taken to avoid damaging O-rings, seals and gaskets when assembling. It is also very important to perform functional tests whenever it is designated.

*: Automatic transmission fluid

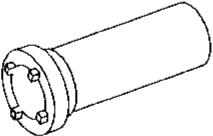
Special Service Tools

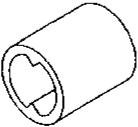
Tool number (Kent-Moore No.) Tool name	Description	Unit application		
		Manual steering	Power steering	
KV48102000 (J28822) End cover socket wrench	 NT168	Removing and installing rear cover and end cover	X	X
KV48100700 (J26364) Torque adapter	 NT169	Measuring pinion rotating torque	—	X
KV48101100 (J26364) Torque adapter	 NT169	Measuring pinion rotating torque	X	—

PRECAUTIONS AND PREPARATION

Special Service Tools (Cont'd)

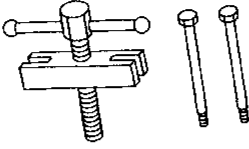
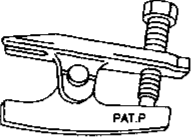
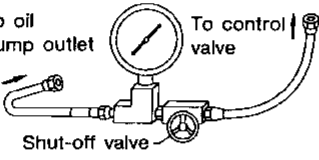
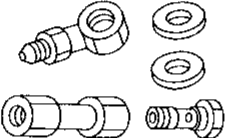
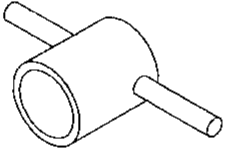
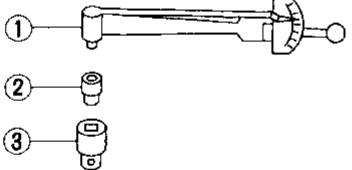
Tool number (Kent-Moore No.) Tool name	Description	Unit application			
		Manual steering	Power steering		
ST27180001 (J25726-A) Steering wheel puller	 NT170	Removing and installing steering wheel	X	X	GI MA
HT72520000 (J25730-A) Ball joint remover	 NT146	Removing ball joint	X	X	EM LC
ST27091000 (J26357) Pressure gauge	 NT176	Measuring oil pressure	—	X	EF & EC FE
KV48102500 (—) Pressure gauge adapter	 NT177	Measuring oil pressure	—	X	CL MT
KV48104400 (—) Rack seal ring reformer	 NT178	Reforming teflon ring	—	X	AT FA
ST3127S000 ① GG91030000 (See J25765-A) Torque wrench ② HT62940000 (—) Socket adapter ③ HT62900000 (—) Socket adapter	 NT124	Measuring turning torque	X	X	RA BR ST BF

HA

EL

IDX

PRECAUTIONS AND PREPARATION

Commercial Service Tools

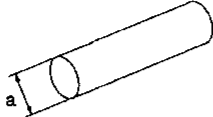
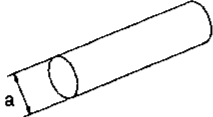
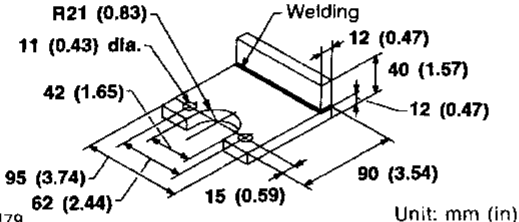
Tool name	Description	Unit application	
		Manual steering	Power steering
Rear oil seal drift	 <p>Installing rear oil seal a : 28 mm (1.10) dia.</p> <p>NT063</p>	—	X
Pinion oil seal drift	 <p>Installing pinion oil seal a : 35 mm (1.38 in) dia.</p> <p>NT063</p>	—	X
Oil pump attachment	 <p>Disassembling and assembling oil pump</p> <p>Unit: mm (in)</p> <p>NT179</p>	— (For oil pump)	— (For oil pump)

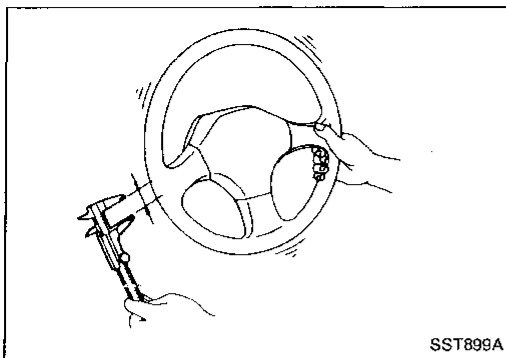

SST899A

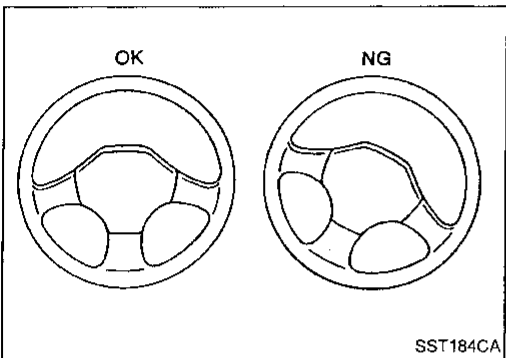

SST184CA

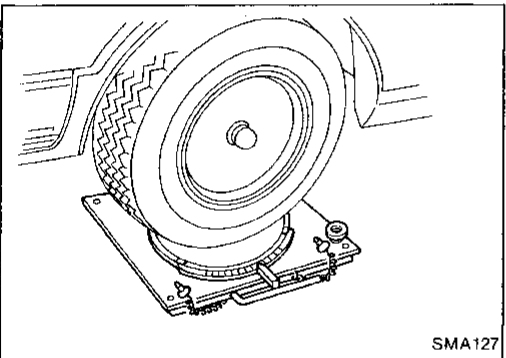

SMA127

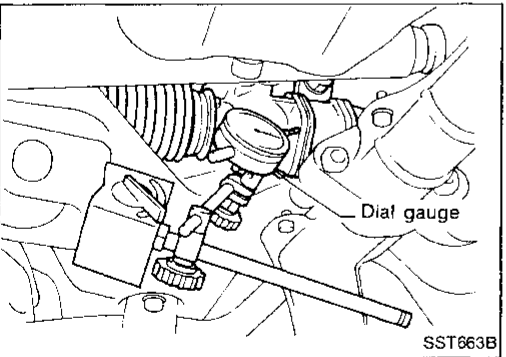

SST863B

Checking Steering Wheel Play

1. With wheels in a straight-ahead position, check steering wheel play.

Steering wheel play: 35 mm (1.38 in) or less

2. If it is not within specification, check steering gear assembly when front suspension and axle, steering gear assembly and steering column are mounted correctly.

Checking Neutral Position on Steering Wheel Pre-checking

- Make sure that wheel alignment is correct.
Wheel alignment: Refer to section FA for SDS.
- Verify that the steering gear is centered before removing the steering wheel.

Checking

1. Check that the steering wheel is in the neutral position when driving straight ahead.
2. If it is not in the neutral position, remove the steering wheel and reinstall it correctly.
3. If the neutral position is between two serrated teeth, loosen tie-rod lock nut and move tie-rod in the opposite direction by the same amount on both left and right sides to compensate for error in the neutral position.

Front Wheel Turning Angle

1. Rotate steering wheel all the way right and left; measure turning angle.

Turning angle of full turns:

Refer to section FA for SDS.

2. If it is not within specification, check rack stroke.

Rack stroke "L":

Refer to SDS.

Checking Gear Housing Movement

1. Check the movement of steering gear housing during stationary steering on a dry paved surface.

- Apply a force of 49 N (5 kg, 11 lb) to steering wheel to check the gear housing movement.

Turn off ignition key while checking.

Movement of gear housing:

± 2 mm (± 0.08 in) or less

2. If movement exceeds the limit, replace mount insulator after confirming proper installation of gear housing clamps.

Checking and Adjusting Drive Belts (For power steering)

Refer to section MA for Drive Belt Inspection.

GI

MA

EM

LC

EF &
EC

FE

CL

MT

AT

FA

RA

BR

ST

BF

HA

EL

IDX

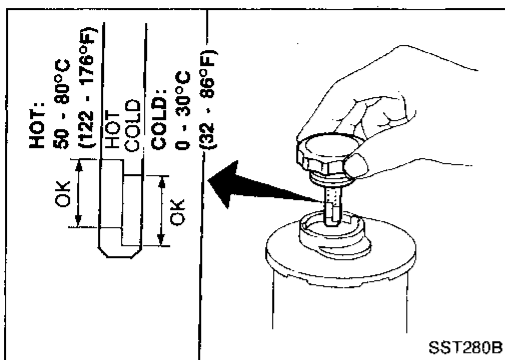

Checking Fluid Level

Check fluid level.

Fluid level should be checked using "HOT" range on dipstick at fluid temperatures of 50 to 80°C (122 to 176°F) or using "COLD" range on dipstick at fluid temperatures of 0 to 30°C (32 to 86°F).

CAUTION:

- Do not overfill.
- Recommended fluid is Automatic Transmission Fluid type "DEXRON™II" or equivalent.

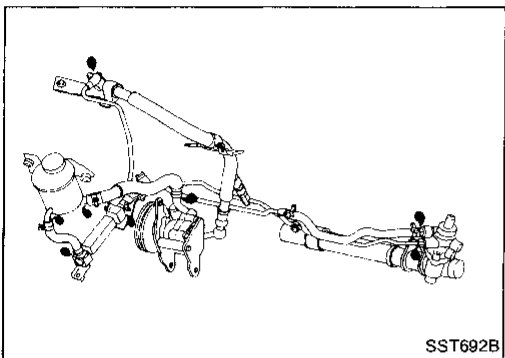

Checking Fluid Leakage

Check the lines for improper attachment and for leaks, cracks, damage, loose connections, chafing or deterioration.

1. Run engine between idle speed and 1,000 rpm.

Make sure temperature of fluid in oil tank rises to 60 to 80°C (140 to 176°F).

2. Turn steering wheel right-to-left several times.
3. Hold steering wheel at each "lock" position for five seconds and carefully check for fluid leakage.

CAUTION:

Do not hold the steering wheel in a locked position for more than 15 seconds.

4. If fluid leakage at connectors is noticed, loosen flare nut and then retighten.

Do not overtighten connector as this can damage O-ring, washer and connector.

Bleeding Hydraulic System

1. Raise front end of vehicle until wheels are clear of the ground.
2. Add fluid into oil tank to specified level. Meanwhile quickly turn steering wheel fully to right and left and lightly touch steering stoppers.
Repeat steering wheel operation until fluid level no longer decreases.
3. Start engine.
Repeat step 2 above.

- Incomplete air bleeding will cause the following to occur. When this happens, bleed air again.
 - a. Generation of air bubbles in reservoir tank
 - b. Generation of clicking noise in oil pump
 - c. Excessive buzzing in oil pump

While the vehicle is stationary or while moving the steering wheel slowly, fluid noise may occur in the valve or oil pump. This noise is inherent in this steering system, and it will not affect performance or durability of the system.

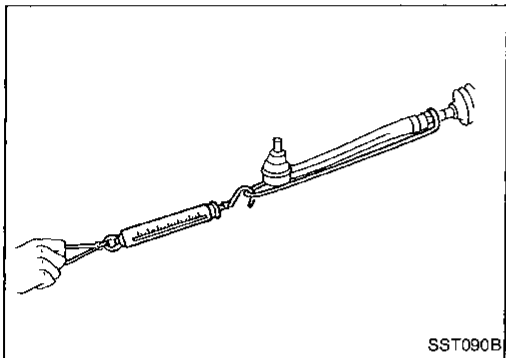
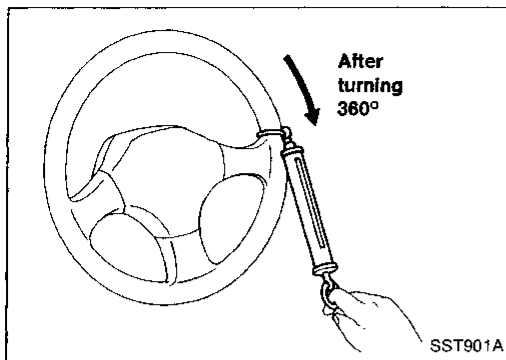

Checking Steering Wheel Turning Force (For power steering)

1. Park vehicle on a level, dry surface and set parking brake.
2. Start engine.
3. Bring power steering fluid up to adequate operating temperature. [Make sure temperature of fluid is approximately 60 to 80°C (140 to 176°F).]

Tires need to be inflated to normal pressure.

4. Check steering wheel turning force when steering wheel has been turned 360° from the neutral position.

Steering wheel turning force: 39 N (4 kg, 9 lb) or less

5. If steering wheel turning force is out of specifications, check rack sliding force to detect condition of steering gear assembly.

- a. Disconnect steering column lower joint and knuckle arms from the gear.
- b. Start and run engine at idle to make sure steering fluid has reached normal operating temperature.

- c. While pulling tie-rod slowly in the ±11.5 mm (±0.453 in) range from the neutral position, make sure rack sliding force is within specification.

Rack sliding force:

147 - 245 N (15 - 25 kg, 33 - 55 lb)

- d. Check sliding force outside above range.

Rack sliding force:

Not more than 294 N (30 kg, 66 lb)

6. If rack sliding force is not within specification, overhaul steering gear assembly.

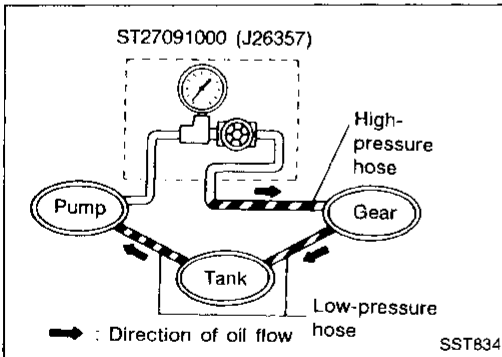

Checking Hydraulic System

Before starting, check belt tension, driving pulley and tire pressure.

1. Set Tool. Open shut-off valve. Then bleed air. (See "Bleeding Hydraulic System".)
2. Run engine.

Make sure temperature of fluid in tank rises to 60 to 80°C (140 to 176°F).

WARNING:

Warm up engine with shut-off valve fully opened. If engine is started with shut-off valve closed, oil pressure in oil pump will increase to relief pressure, resulting in an abnormal rise in oil temperature.

3. Check pressure with steering wheel fully turned to left and right positions with engine idling at 1,000 rpm.

CAUTION:

Do not hold the steering wheel in a locked position for more than 15 seconds.

Oil pump maximum standard pressure:

7,649 - 8,238 kPa (78 - 84 kg/cm², 1,109 - 1,194 psi)

GI
MA
EM
LC
EF & EC
FE
CL
MT
AT
FA
RA
BR
ST
BF
HA
EL
IDX

ON-VEHICLE SERVICE

Checking Hydraulic System (Cont'd)

4. If oil pressure is below the standard pressure, slowly close shut-off valve and check pressure.
 - When pressure reaches standard pressure, gear is damaged.
 - When pressure remains below standard pressure, pump is damaged.

CAUTION:

Do not close shut-off valve for more than 15 seconds.

5. If oil pressure is higher than standard pressure, check oil pump flow control valve.
6. After checking hydraulic system, remove Tool and add fluid as necessary, then completely bleed air out of system.

STEERING WHEEL AND STEERING COLUMN

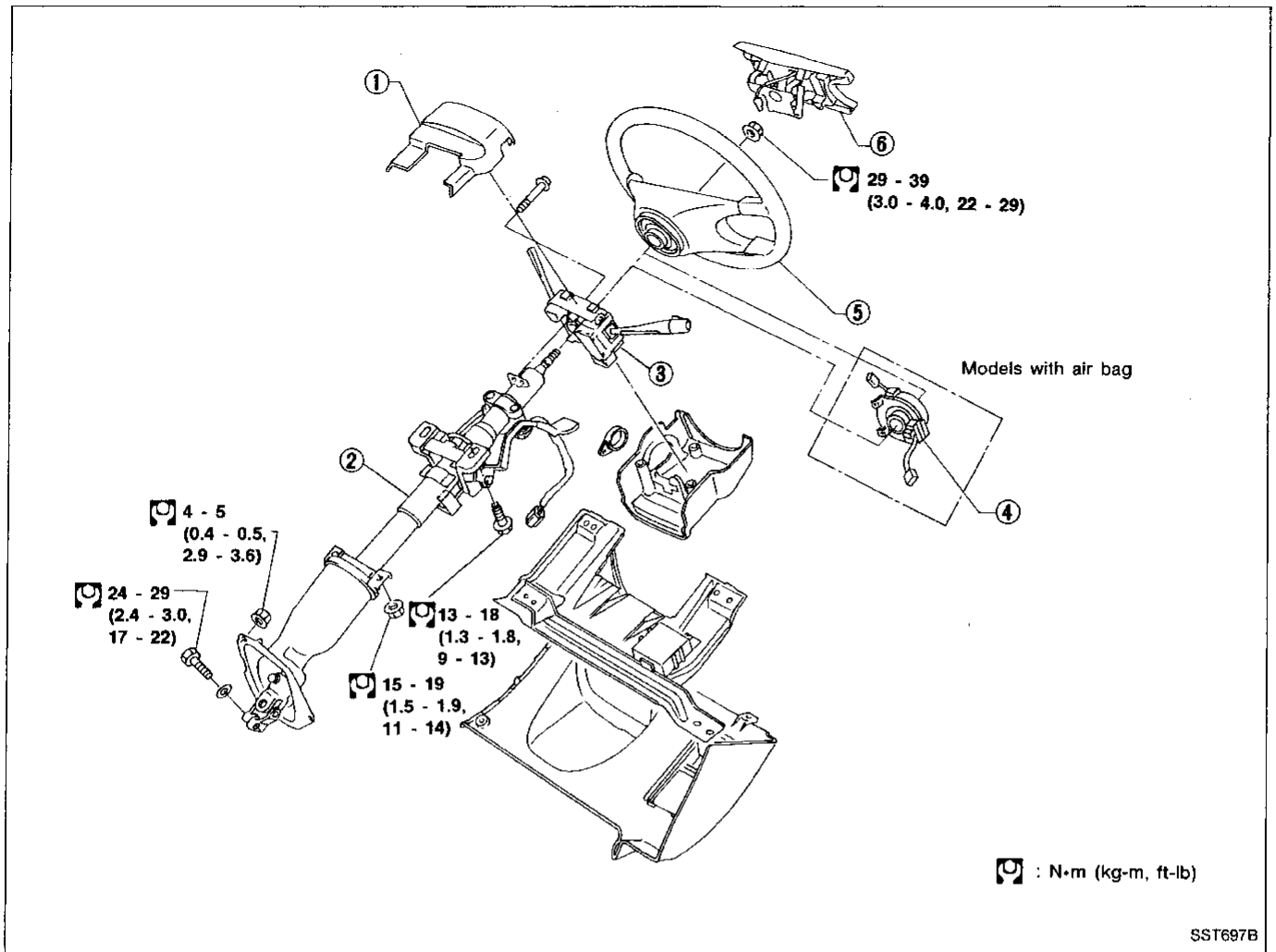

- ① Column cover
- ② Steering column assembly

- ③ Combination switch
- ④ Spiral cable

- ⑤ Steering wheel
- ⑥ Horn pad

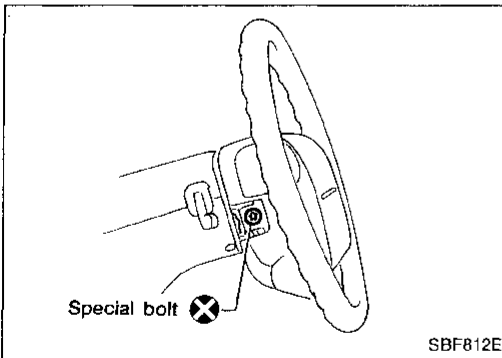

Removal (With air bag)

STEERING WHEEL

Remove air bag module and spiral cable.
Refer to BF section ("Removal — Air Bag Module and Spiral Cable", "SUPPLEMENTAL RESTRAINT SYSTEM").

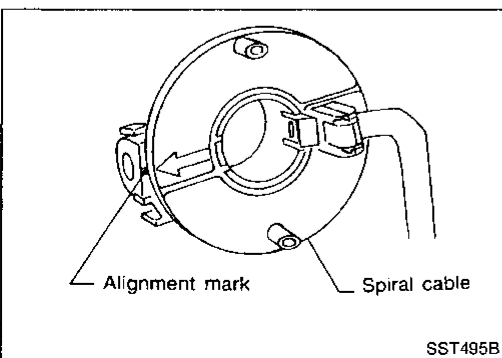

STEERING COLUMN

CAUTION:

The rotation of the spiral cable (SRS "Airbag" component part) is limited. If the steering gear must be removed, set the front wheels in the straight-ahead direction. Do not rotate the steering column while the steering gear is removed.

GI
MA
EM
LC
EF & EC
FE
CL
MT
AT
FA
RA
BR
ST
BF
HA
EL
IDX

STEERING WHEEL AND STEERING COLUMN

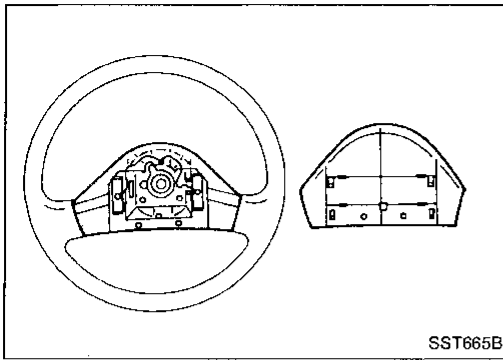

Removal (Without air bag)

STEERING WHEEL

1. Remove horn pad.

— Two spoke type —

- Horn pad is installed using pawls (plastic) and clamps. To remove horn pad, pry pawls by hand and push clamps with a standard screwdriver inserted between pad and steering wheel.

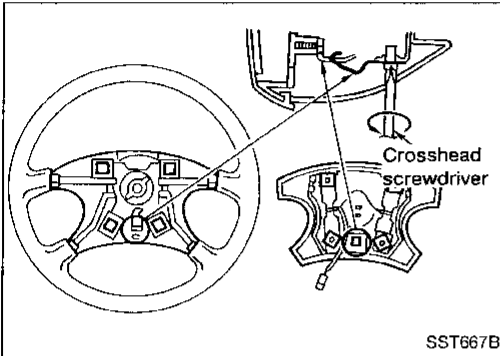

— Four spoke type —

- Insert a crosshead screwdriver into hole on lower side of spoke and remove clamps. Lift horn pad off by hand.

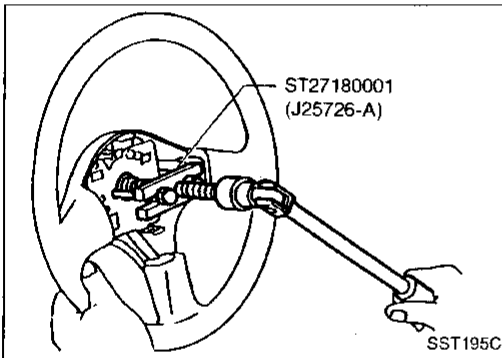

2. Remove steering wheel with Tool.

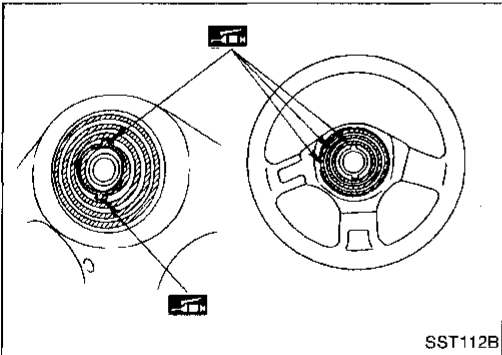

Installation

STEERING WHEEL

When installing steering wheel, apply multi-purpose grease to entire surface of turn signal cancel pin (both portions) and also to horn contact slip ring.

STEERING COLUMN

- When installing steering column, fingertighten all lower bracket and clamp retaining bolts; then tighten them securely. Do not apply undue stress to steering column.

- When attaching coupling joint, be sure tightening bolt faces cutout portion.

CAUTION:

After installing steering column, turn steering wheel to make sure it moves smoothly and that the number of turns from the straight forward position to left and right locks are equal. Be sure that the steering wheel is in a neutral position when driving straight ahead.

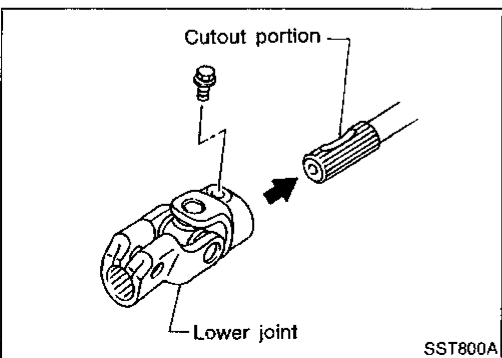

STEERING WHEEL AND STEERING COLUMN

Disassembly and Assembly

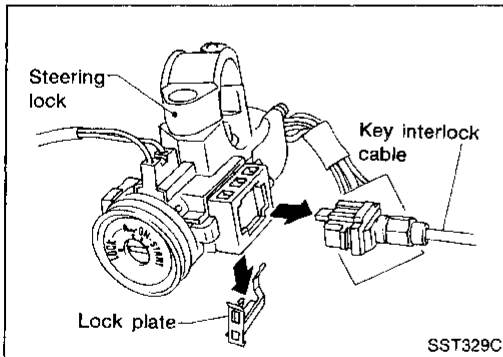
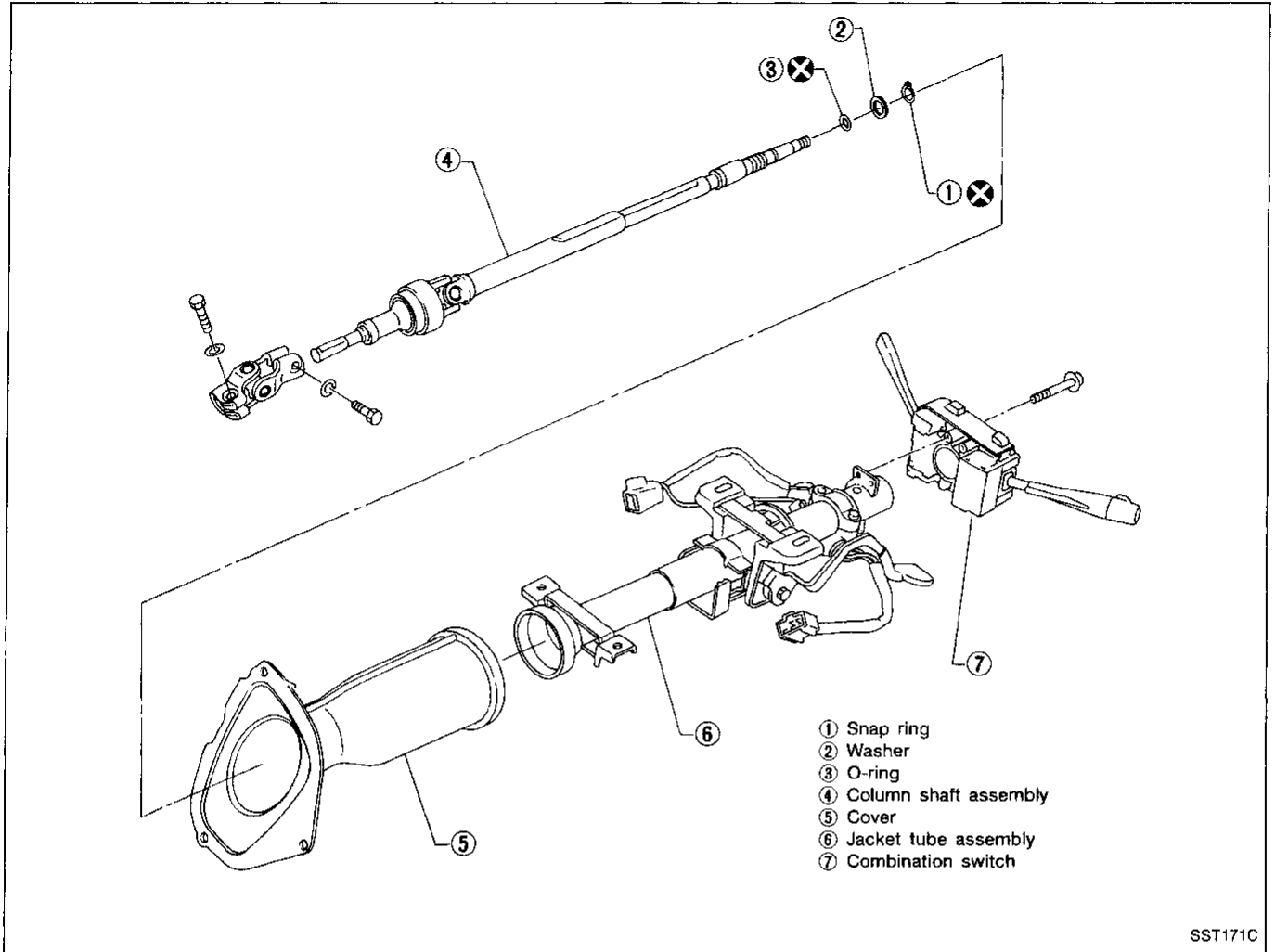

- When disassembling and assembling, unlock steering lock with key.
- Remove combination switch.
- Remove key interlock cable (A/T models).

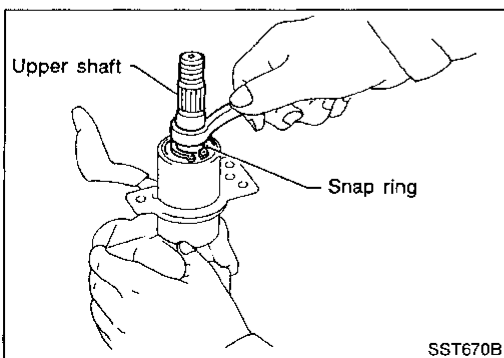

- Ensure that rounded surface of snap ring faces toward bearing when snap ring is installed.
- Install snap ring on upper shaft with a suitable tool.

STEERING WHEEL AND STEERING COLUMN

Disassembly and Assembly (Cont'd)

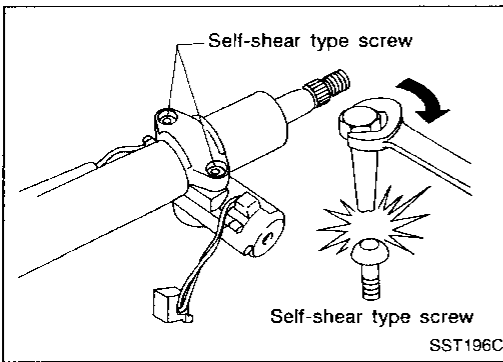

- Steering lock
 - a. Break self-shear type screws with a drill or other appropriate tool.
 - b. Install new self-shear type screws and then cut off self-shear type screw heads.
 - c. Install key interlock cable (A/T models).

Tilt mechanism

- After installing steering column, check tilt mechanism operation.

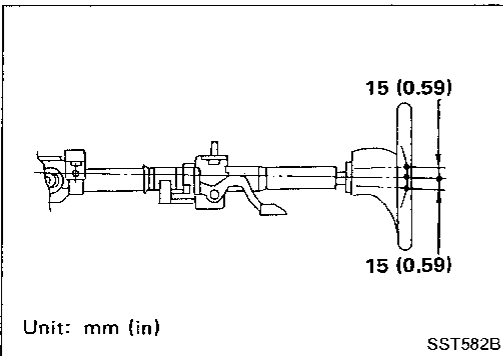

Inspection

- When steering wheel can not be rotated smoothly, check the steering column for the following matters and replace damaged parts.
 - a. Check column bearings for damage or unevenness. Lubricate with recommended multi-purpose grease or replace steering column as an assembly, if necessary.
 - b. Check jacket tube for deformation or breakage. Replace if necessary.
- When the vehicle is involved in a light collision, check column length "L". If it is not within specifications, replace steering column as an assembly.

Column length "L":

Without air bag

533.2 - 534.8 mm (20.99 - 21.06 in)

With air bag

536.2 - 537.8 mm (21.11 - 21.17 in)

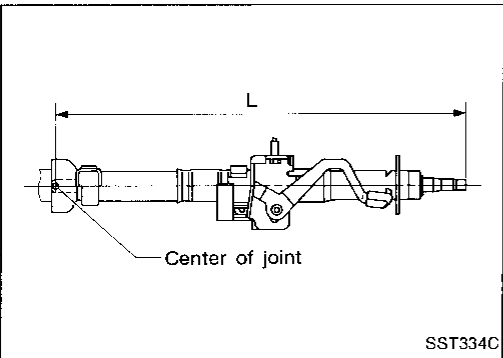

MANUAL STEERING GEAR AND LINKAGE (Model R24N)

Removal and Installation

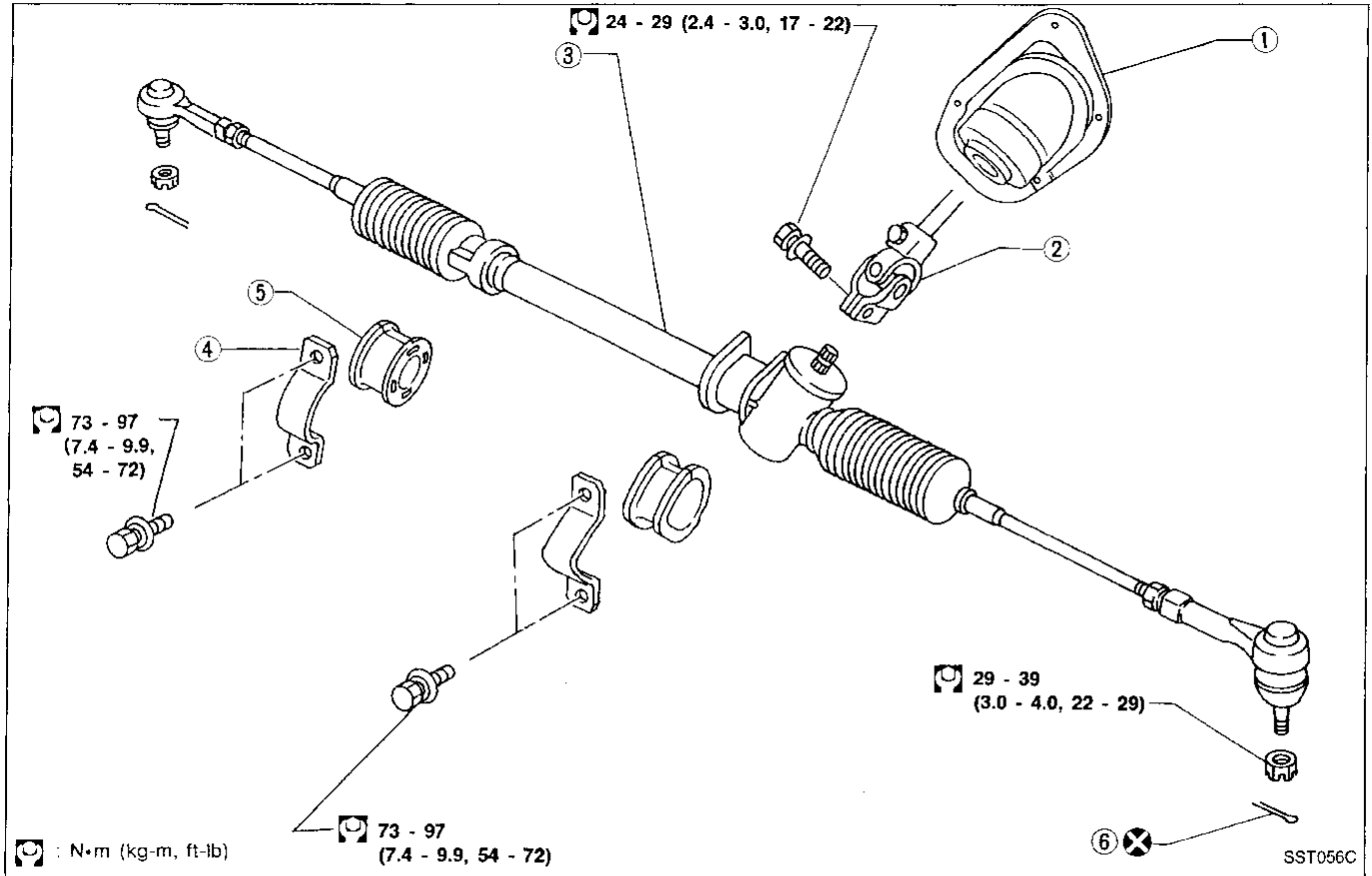

- ① Hole cover
- ② Lower joint
- ③ Manual steering gear assembly
- ④ Steering gear mounting clamp
- ⑤ Rack mounting insulator
- ⑥ Cotter pin

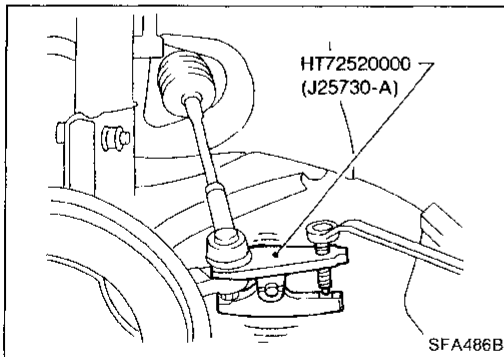

CAUTION:

The rotation of the spiral cable (SRS "Airbag" component part) is limited. If the steering gear must be removed, set the front wheels in the straight-ahead direction. Do not rotate the steering column while the steering gear is removed.

- Detach tie-rod ball studs from knuckle arms with Tool.

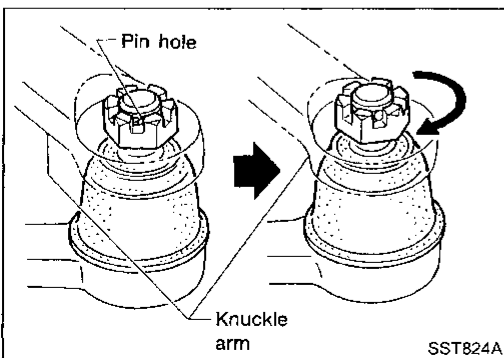

- Initially, tighten nut on tie-rod outer socket and knuckle arm to 29 to 39 N·m (3 to 4 kg-m, 22 to 29 ft-lb).
- Tighten nut further to align nut groove with the first pin hole so cotter pin can be installed.

CAUTION:

Tightening torque must not exceed 49 N·m (5 kg-m, 36 ft-lb).

MANUAL STEERING GEAR AND LINKAGE (Model R24N)

Disassembly

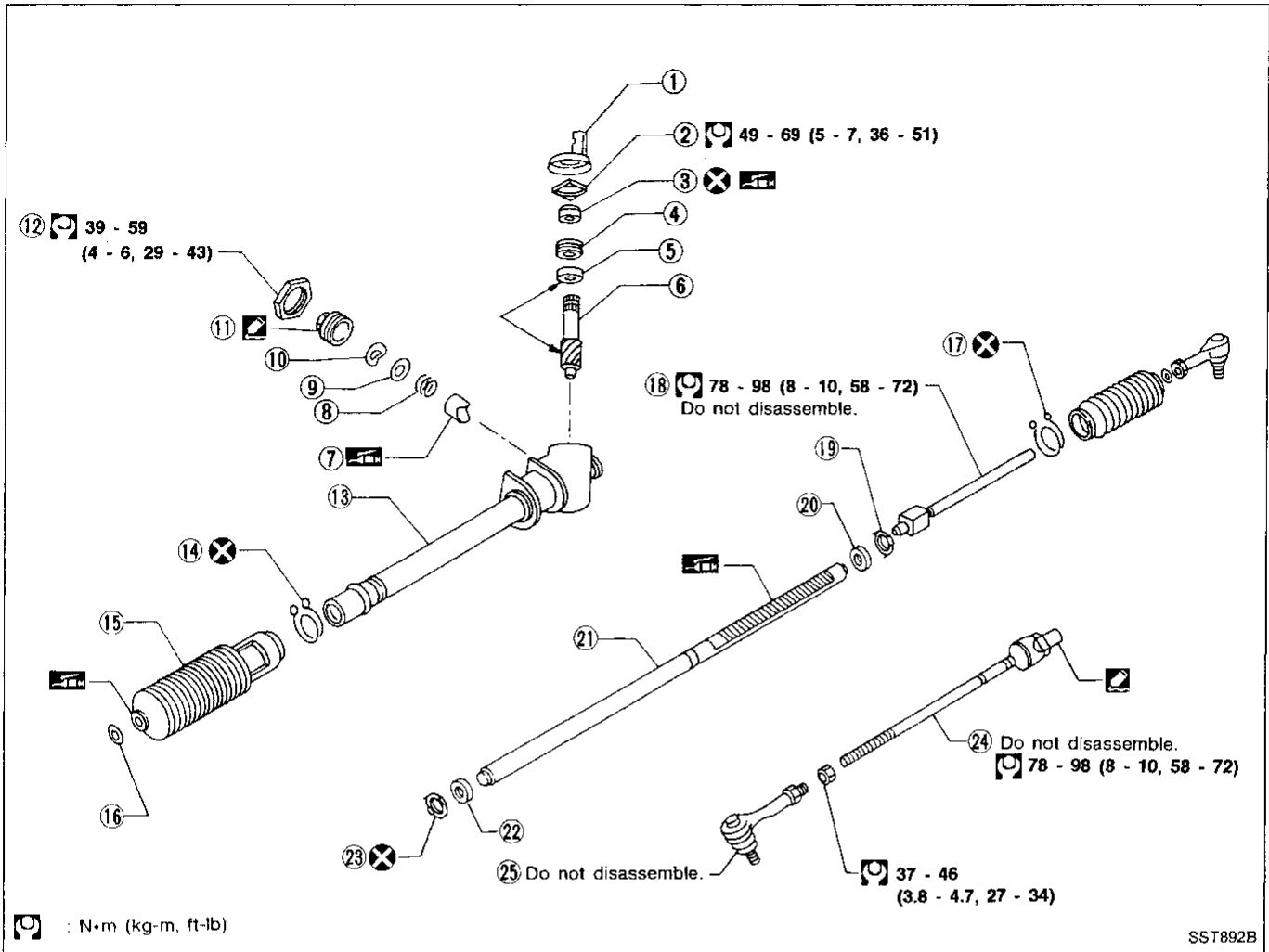

- ① Guide chip
- ② Rear cover lock nut
- ③ Dust seal
- ④ Rear cover
- ⑤ Pinion bearing
- ⑥ Pinion assembly
- ⑦ Retainer
- ⑧ Retaining spring
- ⑨ Plain washer

- ⑩ Wave washer
- ⑪ Adjusting screw
- ⑫ Adjusting lock nut
- ⑬ Gear housing assembly
- ⑭ Boot clamp
- ⑮ Boot
- ⑯ Boot band
- ⑰ Boot clamp

- ⑱ Tie-rod inner socket
- ⑲ Lock plate
- ⑳ Spacer
- ㉑ Rack
- ㉒ Spacer
- ㉓ Lock plate
- ㉔ Tie-rod inner socket
- ㉕ Tie-rod outer socket

Inspection

BOOT

Check condition of boot. If it is cracked excessively, replace it.

RACK

Thoroughly examine rack gear. If rack gear is damaged, cracked or worn, replace.

PINION ASSEMBLY

- Thoroughly examine pinion gear. If pinion gear is damaged, cracked or worn, replace.
- Inspect bearings to see that they roll freely and are free from cracked, pitted, or worn balls, rollers and races. Replace if necessary.

MANUAL STEERING GEAR AND LINKAGE (Model R24N)

Inspection (Cont'd)

TIE-ROD OUTER AND INNER SOCKETS

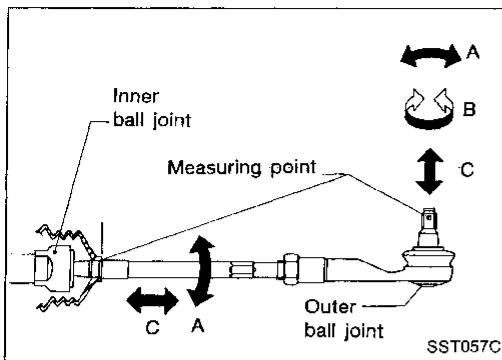

- Check ball joints for swinging force.
Tie-rod outer and inner ball joints swinging force "A": Refer to SDS.
- Check ball joint for rotating torque.
Tie-rod outer ball joint rotating torque "B": Refer to SDS.
- Check ball joints for axial end play.
Tie-rod outer and inner ball joints axial end play "C": Refer to SDS.
- Check condition of dust cover. If cracked excessively, replace.

GI

MA

EM

LC

EF &
EC

FE

CL

MT

AT

FA

RA

BR

ST

BF

HA

EL

IDX

Assembly and Adjustment

STEERING GEAR

1. Insert rack gear from gear housing side.
 2. Set rack gear in neutral position.
 3. Insert pinion assembly, then set guide chip at neutral position as shown in figure. Pinion rack gear should be held in place.
 4. Install rear cover with Tool and secure with lock nut.
Tool number: KV48102000 (J28822)
 - Before installing rear cover, apply locking sealant to threaded areas. Do not allow sealant to get into pinion bearing.
 - Apply a coat of multi-purpose grease to sealing lips of dust seal.
- CAUTION:**
Wrap cellophane tape around pinion gear end when installing dust seal.
5. Insert retainer, spring, plain washer and wave washer. Then, install adjusting screw.
 - Apply a coat of locking sealant to threaded areas of retainer cover.

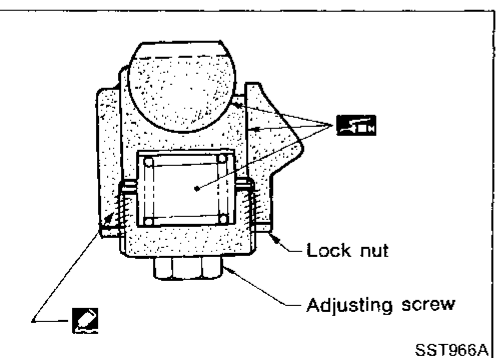
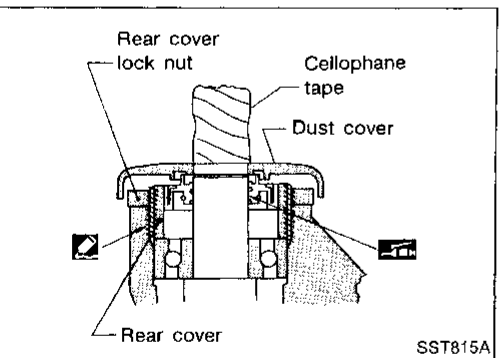
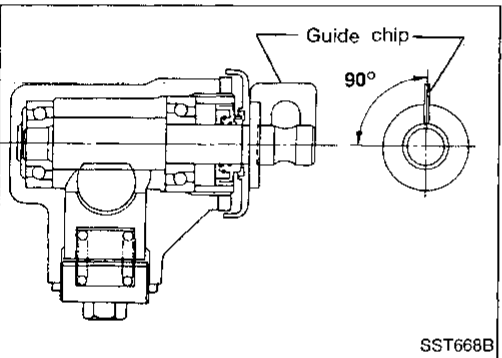
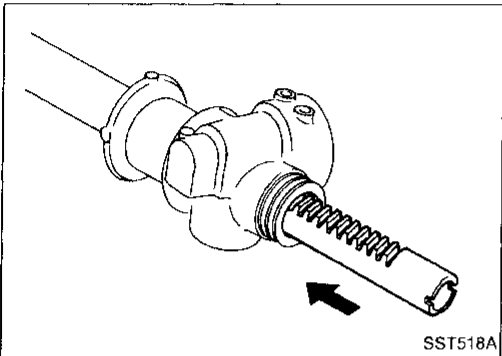

MANUAL STEERING GEAR AND LINKAGE (Model R24N)

Assembly and Adjustment (Cont'd)

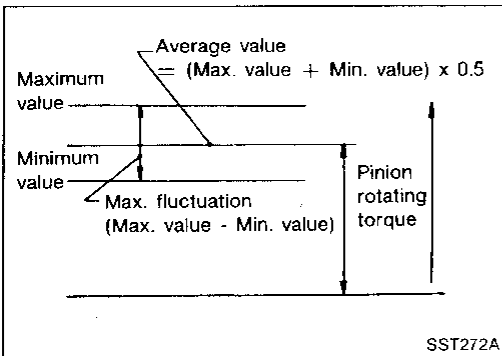
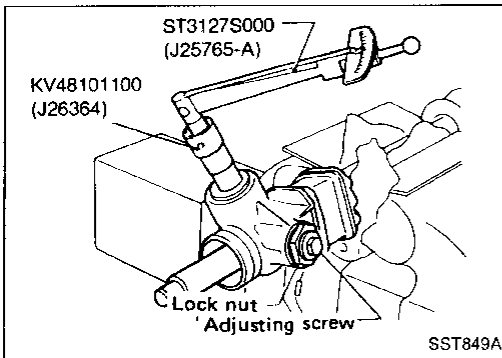

6. Adjust pinion rotating torque as follows:
 - a. Set gears to Neutral position.
 - b. Loosen lock nut.
 - c. Tighten adjusting screw to a torque of 9.8 N·m (100 kg-cm, 87 in-lb).
 - d. Loosen adjusting screw and retighten it to a torque of 9.8 N·m (100 kg-cm, 87 in-lb).
 - e. Loosen adjusting screw within 60° until specified pinion torque is obtained. Ensure that pinion-to-rack play is less than 0.1 mm (0.004 in) when 15 N·m (1.5 kg-m, 11 ft-lb) torque is applied to pinion.
 - f. Prevent adjusting nut from rotating and tighten lock nut to specified torque 39 to 59 N·m (4 to 6 kg-m, 29 to 43 ft-lb) holding adjusting screw in place.
 - g. While slowly rotating pinion in the ±100° range from Neutral position, make sure its rotating torque is within the specifications.

Within ±100° from the neutral position:

Average rotating torque

0.7 - 1.2 N·m (7 - 12 kg-cm, 6.1 - 10.4 in-lb)

Maximum torque deviation

0.3 N·m (3 kg-cm, 2.6 in-lb)

Except for above measuring range:

Maximum rotating torque

1.5 N·m (15 kg-cm, 13 in-lb)

Maximum force deviation

0.5 N·m (5 kg-cm, 4.3 in-lb)

- h. If pinion rotating torque is not within the specifications, readjust.

If pinion rotating torque is outside the specifications after adjustment has been made, retainer spring needs replacement. If pinion rotating torque is still out of specifications after replacing retainer spring, gear assembly needs to be replaced.

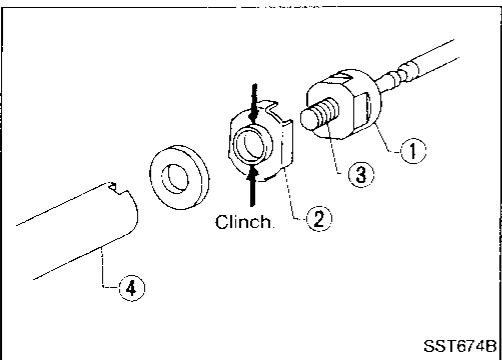

7. Install new lock plate.
 - Attach lock plate ② to side rod inner socket ①.
 - Apply locking sealant to inner socket threads ③. Screw inner socket into rack ④ and tighten to specified torque.
 - Clinch two places of lock plate at rack's groove.

CAUTION:

To prevent scratching the boot, remove burrs from lock plate.

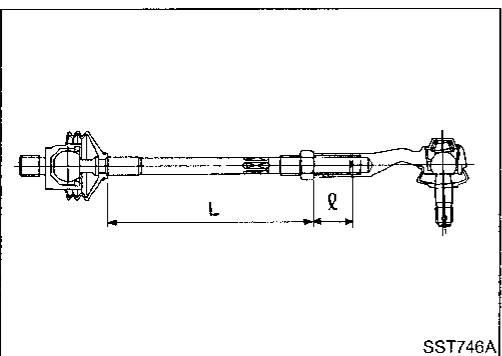

TIE-ROD AND BOOT

1. Install boot on tie-rod inner socket.
2. Apply locking sealant to threaded portion of inner socket and install tie-rod inner socket to rack end together with new lock plate.
3. Install lock nut and outer socket to inner socket. Adjust tie-rod length "L" and tighten lock nut.

Tie-rod length "L": Refer to SDS.

Screwed length "l": 32 mm (1.26 in) or more

MANUAL STEERING GEAR AND LINKAGE (Model R24N)

Assembly and Adjustment (Cont'd)

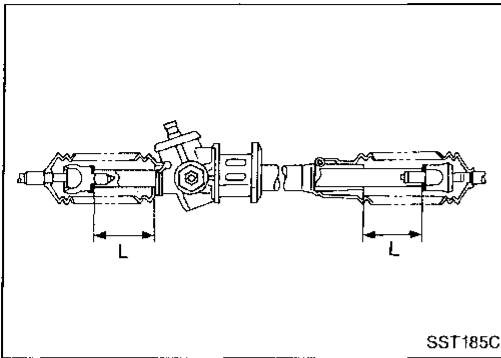

4. Measure rack stroke.
Measure length "L":
Refer to SDS.

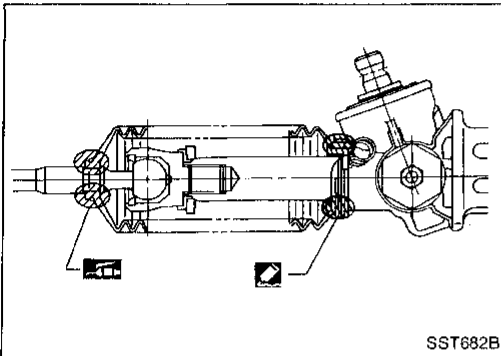

5. Install boot to gear housing.
Apply sealant between boot and gear housing.

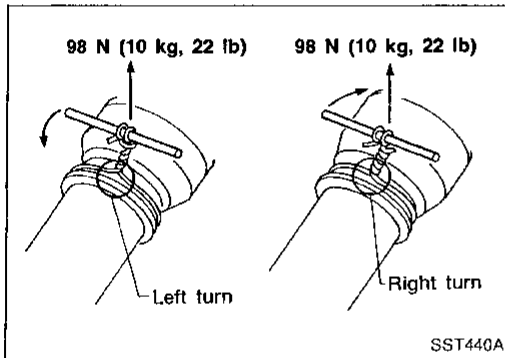

6. Install boot clamps.
 - To install, wrap boot clamp around boot groove twice. Tighten clamp by twisting rings at both ends four or four and one-half turns with screwdriver while pulling with a force of approx. 98 N (10 kg, 22 lb).

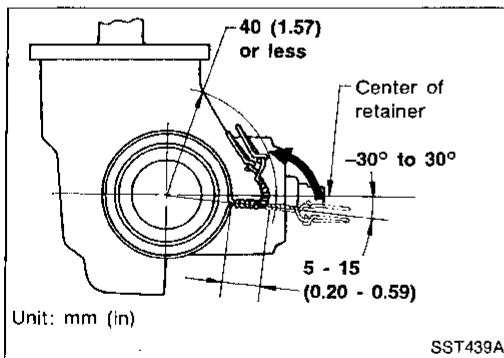

- Install boot clamp so that it is to the rear of the vehicle when gear housing is attached to the body. (This will avoid interference with other parts.)

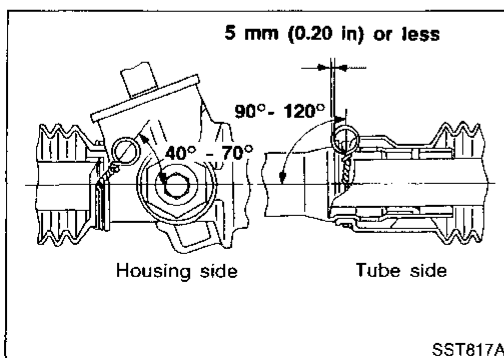

- After twisting boot clamp four or four and one-half turns, bend twisted end diagonally so it does not contact boot.

GI

MA

EM

LC

EF &
EC

FE

CL

MT

AT

FA

RA

BR

ST

BF

HA

EL

IDX

POWER STEERING GEAR AND LINKAGE (Model PR24AC)

Removal and Installation

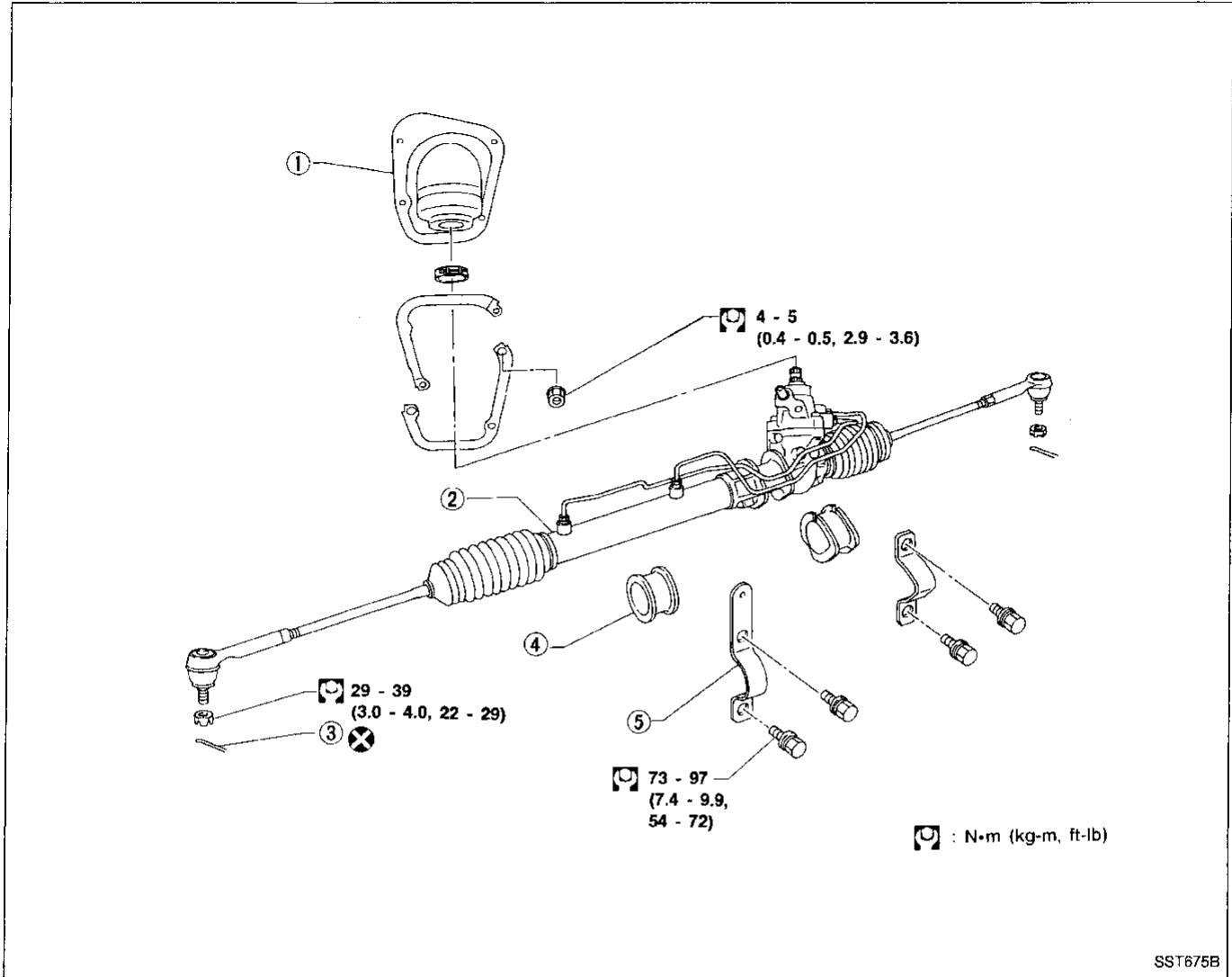

- ① Hole cover
- ② Gear and linkage assembly
- ③ Cotter pin
- ④ Rack mounting insulator
- ⑤ Gear housing mounting bracket

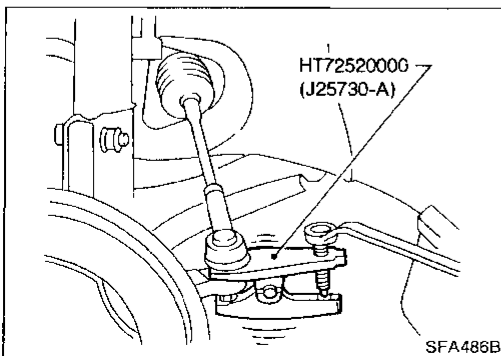

- Detach tie-rod outer sockets from knuckle arms with Tool.

POWER STEERING GEAR AND LINKAGE (Model PR24AC)

Removal and Installation (Cont'd)

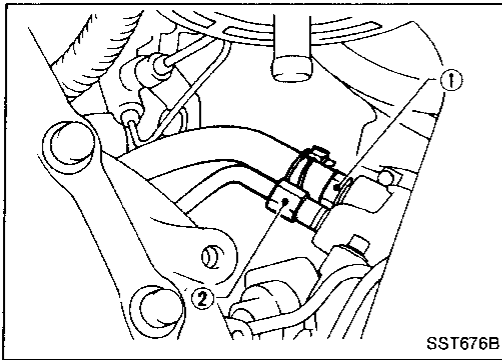

- Install pipe connector.
- Observe specified tightening torque when tightening high-pressure and low-pressure pipe connectors. Excessive tightening will damage threads of connector or O-ring.

Connector tightening torque:

Low-pressure side "1"

27 - 39 N·m (2.8 - 4.0 kg·m, 20 - 29 ft·lb)

High-pressure side "2"

15 - 25 N·m (1.5 - 2.5 kg·m, 11 - 18 ft·lb)

- The O-ring in low-pressure pipe connector is larger than that in high-pressure connector. Take care to install the proper O-ring.

GI

MA

EM

LC

EF &
EC

FE

CL

MT

AT

FA

RA

BR

ST

BF

HA

EL

IDX

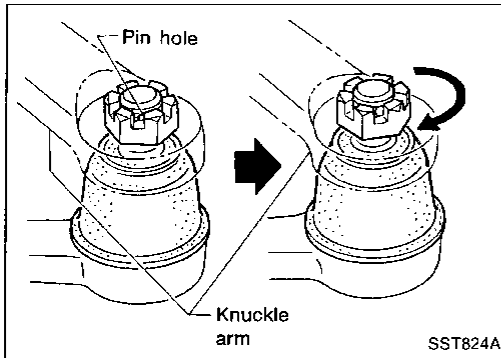

- Initially, tighten nut on tie-rod outer socket and knuckle arm to 29 to 39 N·m (3 to 4 kg·m, 22 to 29 ft·lb). Then tighten further to align nut groove with first pin hole so that cotter pin can be installed.

CAUTION:

Tightening torque must not exceed 49 N·m (5 kg·m, 36 ft·lb).

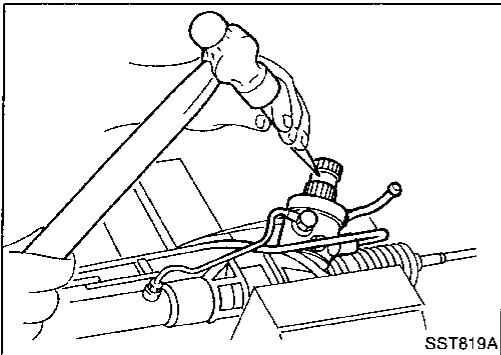

- Before removing lower joint from gear, set gear in neutral (wheels in straight-ahead position). After removing lower joint, put matching mark on pinion shaft and pinion housing to record neutral position of gear.
- To install, set left and right dust boots to equal deflection, and attach lower joint by aligning matching marks of pinion shaft and pinion housing.

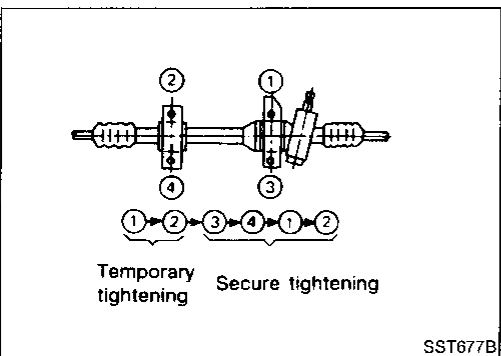

- Tighten gear housing mounting bracket bolts in the order shown.

POWER STEERING GEAR AND LINKAGE (Model PR24AC)

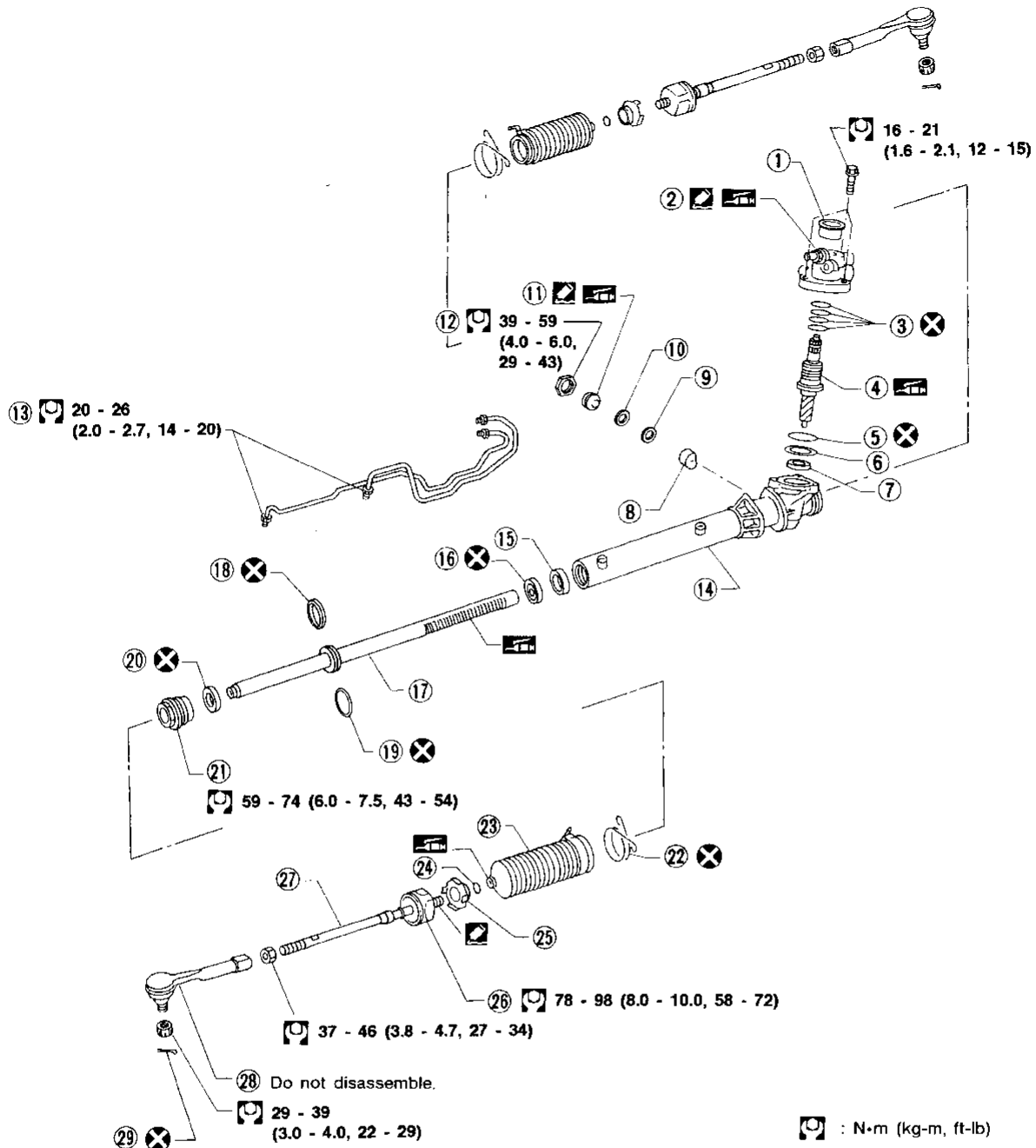

SST678B

- | | | |
|-------------------------|---------------------|------------------------|
| ① Rear housing cover | ⑪ Adjusting screw | ⑳ End cover assembly |
| ② Rear housing assembly | ⑫ Lock nut | ㉑ Boot clamp |
| ③ Pinion seal ring | ⑬ Gear housing tube | ㉒ Dust boot |
| ④ Pinion assembly | ⑭ Gear housing | ㉓ Boot band |
| ⑤ O-ring | ⑮ Center bushing | ㉔ Lock plate |
| ⑥ Shim | ⑯ Rack oil seal | ㉕ Tie-rod inner socket |
| ⑦ Pinion oil seal | ⑰ Rack assembly | ㉖ Tie-rod |
| ⑧ Retainer | ⑱ Rack seal ring | ㉗ Tie-rod outer |
| ⑨ Washer | ㉒ O-ring | ㉘ Cotter pin |
| ⑩ Spring disc | ㉓ Rack oil seal | |

POWER STEERING GEAR AND LINKAGE (Model PR24AC)

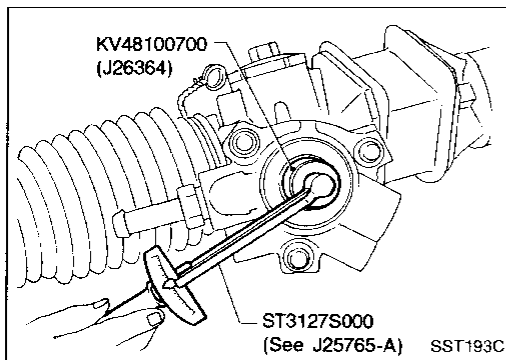

Disassembly

1. Prior to disassembling, measure pinion rotating torque. Record the pinion rotating torque as a reference. Refer to step 11 of "Adjustment" for reference torque data.

- Before measuring, disconnect gear housing tube and drain fluid.
- Use soft jaws when holding steering gear housing. Handle gear housing carefully, as it is made of aluminum. Do not grip cylinder in a vise.

2. Remove pinion gear.

Be careful not to damage pinion gear when removing pinion seal ring.

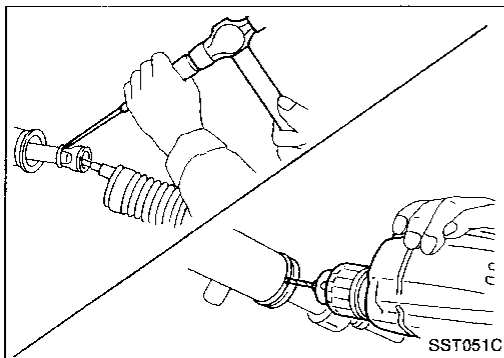

3. Remove tie-rod outer sockets and boots.
4. Loosen tie-rod inner socket by prying up staked portion, and remove socket.
5. Remove retainer.
6. Remove pinion assembly.
7. Drill staked portion of gear housing end with drill of 2 to 2.5 mm (0.079 to 0.098 in) diameter, until the staking is eliminated.

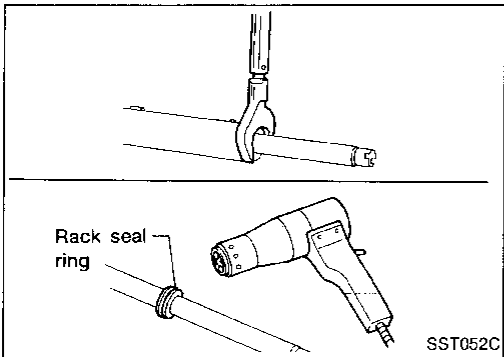

8. Remove end cover assembly with a suitable tool.
9. Draw out rack assembly.
10. Remove rack seal ring.
 - Using a heat gun, heat rack seal to approximately 40°C (104°F).
 - Remove rack seal ring.

Be careful not to damage rack.

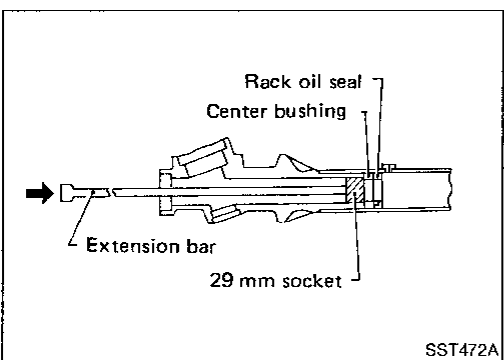

11. Remove center bushing and rack oil seal using tape wrapped socket and extension bar.

Do not scratch inner surfaces of pinion housing.

POWER STEERING GEAR AND LINKAGE (Model PR24AC)

Inspection

Thoroughly clean all parts in cleaning solvent or automatic transmission fluid type DEXRON™II or equivalent, and blow dry with compressed air, if available.

BOOT

Check condition of boot. If cracked excessively, replace it.

RACK

Thoroughly examine rack gear. If damaged, cracked or worn, replace it.

PINION ASSEMBLY

- Thoroughly examine pinion gear. If pinion gear is damaged, cracked or worn, replace it.
- Inspect bearings to see that they roll freely and are free from cracked, pitted, or worn balls, rollers and races. Replace if necessary.

GEAR HOUSING CYLINDER

Check gear housing cylinder bore for scratches or other damage. Replace if necessary.

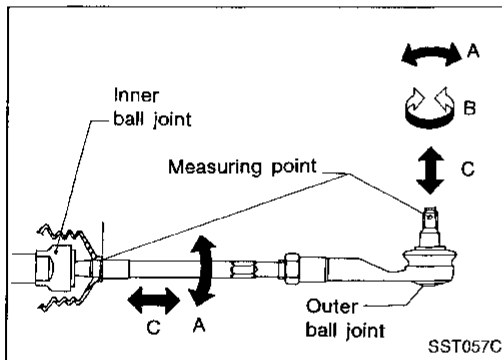

TIE-ROD OUTER AND INNER SOCKETS

- Check ball joints for swinging force.
Tie-rod outer and inner ball joints swinging force "A": Refer to SDS.
- Check ball joint for rotating torque.
Tie-rod outer ball joint rotating torque "B": Refer to SDS.
- Check ball joints for axial end play.
Tie-rod outer and inner ball joints axial end play "C": Refer to SDS.
- Check condition of dust cover. If cracked excessively, replace outer tie-rod.

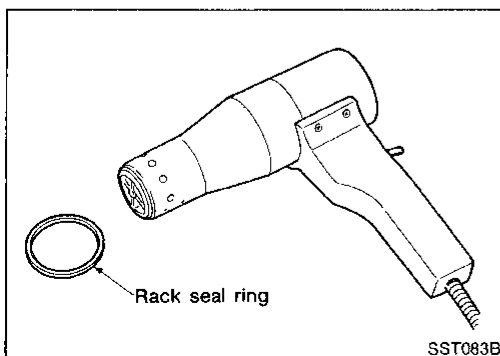

Assembly

1. Using a heat gun, heat new rack seal ring (made of Teflon) to approximately 40°C (104°F) and install it onto rack with your hand.

POWER STEERING GEAR AND LINKAGE (Model PR24AC)

Assembly (Cont'd)

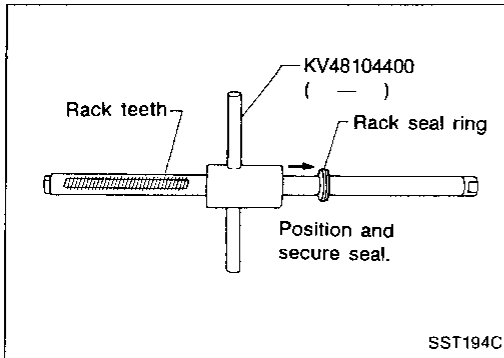

- Using Tool, compress periphery of rack seal ring to position and secure it on rack.

Always insert Tool from the rack gear side.

GI

MA

EM

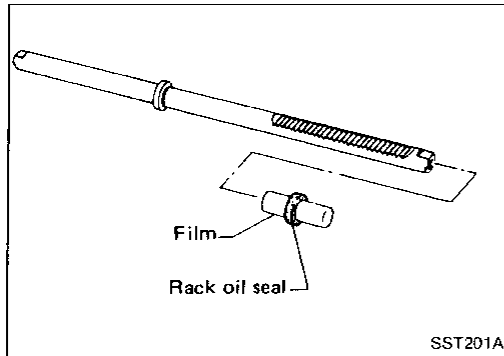

- Insert new rack oil seal.

- Place plastic film into rack oil seal to prevent damage by rack teeth.
- Do not forget to remove plastic film after rack oil seal is positioned properly.
- Make sure lips of rack oil seal face each other.

LC

EF &
EC

FE

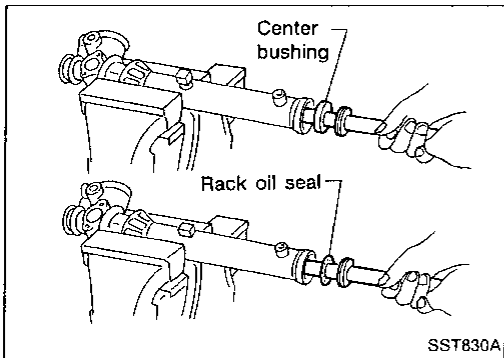

- Install center bushing and rack oil seal with rack assembly.

CL

MT

AT

FA

RA

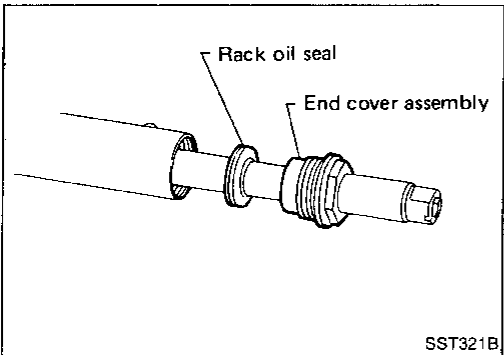

- Insert rack oil seal and end cover assembly to rack, then tighten end cover assembly with a suitable tool.

BR

ST

BF

HA

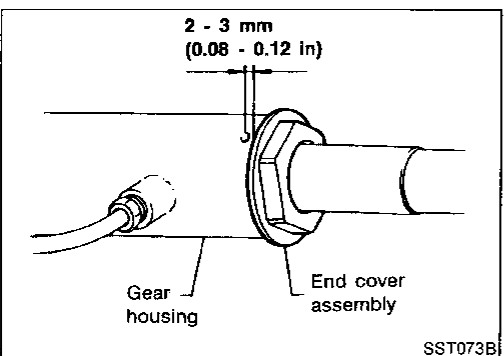

- Fasten end cover assembly to gear housing by staking.

EL

IDX

POWER STEERING GEAR AND LINKAGE (Model PR24AC)

Assembly (Cont'd)

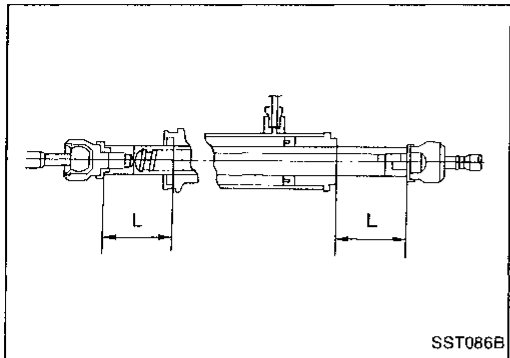

7. Set rack gear in neutral position.

Rack stroke "L":
Refer to SDS.

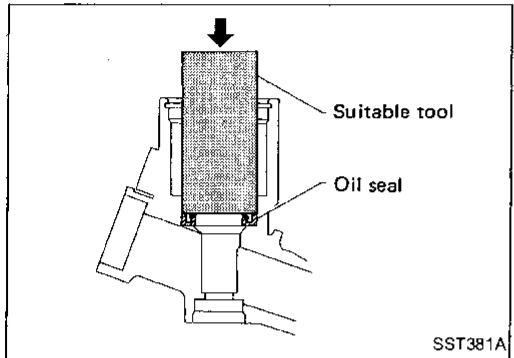

8. Coat seal lip of new pinion oil seal with multi-purpose grease and install it to pinion housing of gear housing with a suitable tool.

Make sure lip of oil seal faces up when installed.

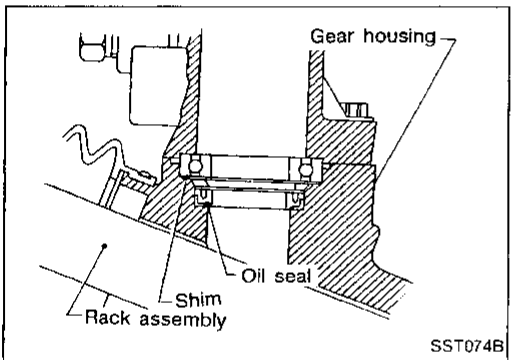

9. Install pinion bearing adjusting shim(s).

- Whenever pinion assembly, gear housing and rear housing are disassembled, replace shim(s) with new ones. Always use the same number of shim(s) when replacing.

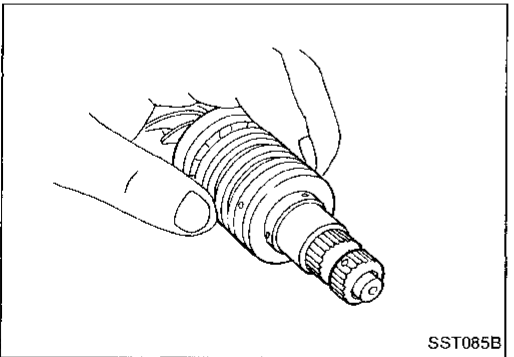

10. Install new pinion seal ring (made of Teflon) on pinion gear assembly.

- Using a heat gun, heat pinion seal ring to approximately 40°C (104°F) before installing it onto pinion gear assembly.
- Make sure pinion seal ring is properly settled in valve groove.

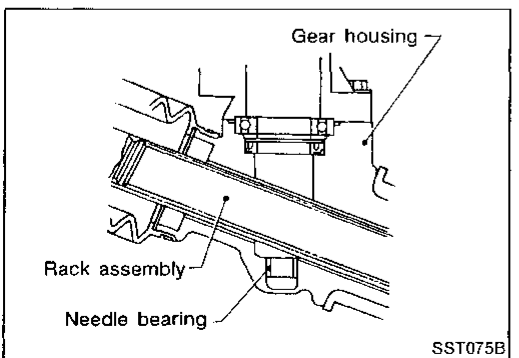

11. Apply a coat of multi-purpose grease to needle bearing roller and oil seal lip before installing pinion assembly in gear housing.

POWER STEERING GEAR AND LINKAGE (Model PR24AC)

Assembly (Cont'd)

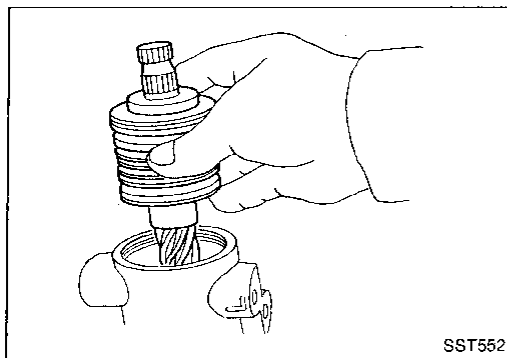

12. Install pinion assembly to pinion housing.
Be careful not to damage pinion oil seal.

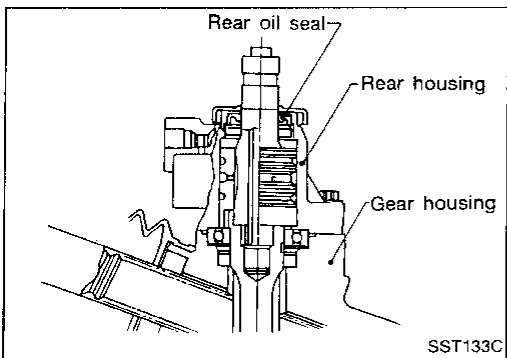

13. Apply a coat of multi-purpose grease to new rear oil seal lip before installing rear housing.

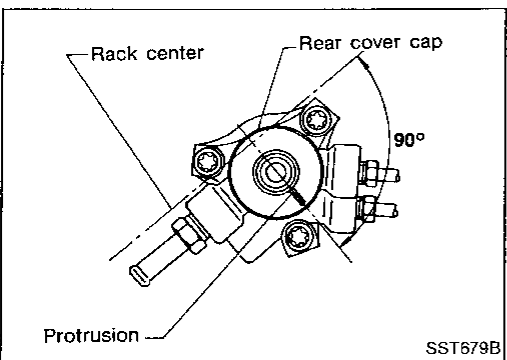

14. Install rear cover cap so that protrusion of rear housing cover is positioned as shown in figure at left when rack is centralized.
Be careful not to damage worm ring and oil seal.

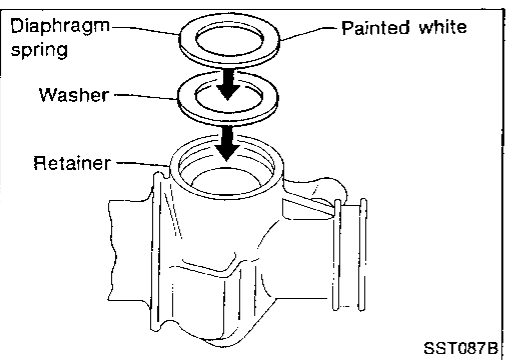

15. Install diaphragm spring into gear housing.
- Always install retainer, spring washer and diaphragm spring in that order.
 - Make sure convex end (painted white) of diaphragm spring faces outward when installing.
16. Install retainer and adjusting screw temporarily.

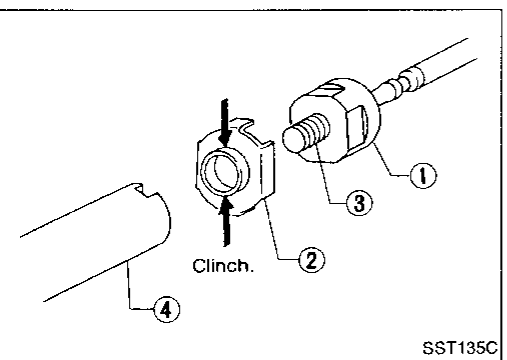

17. Install new lock plate.
- Attach lock plate ② to tie-rod inner socket ①.
 - Apply locking sealant to inner socket threads ③. Screw inner socket into rack ④ and tighten to specified torque.
 - Clinch two places of lock plate at rack's groove.

CAUTION:

To prevent scratching the boot, remove burrs from lock plate.

GI

MA

EM

LC

EF &
EC

FE

CL

MT

AT

FA

RA

BR

ST

BF

HA

EL

IDX

POWER STEERING GEAR AND LINKAGE (Model PR24AC)

Assembly (Cont'd)

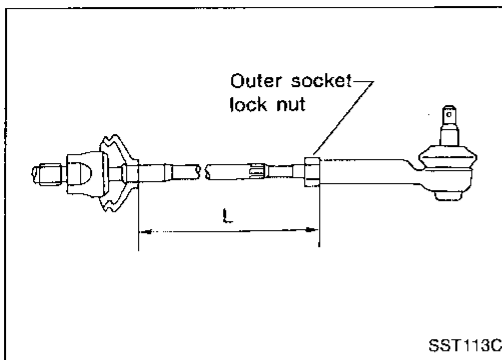

18. Tighten outer socket lock nut.

Tie-rod length "L":
Refer to SDS.

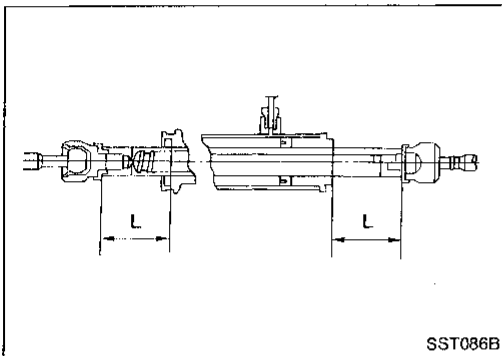

19. Measure rack stroke.

Rack stroke "L":
Refer to SDS.

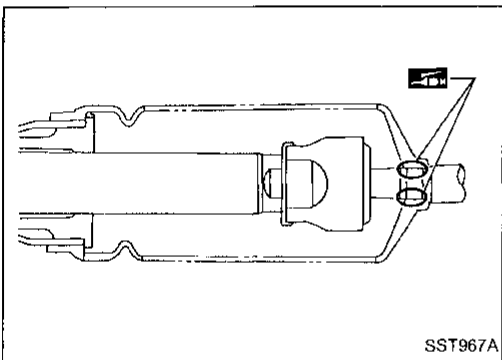

20. Before installing boot, coat the contact surfaces between boot and tie-rod with grease.

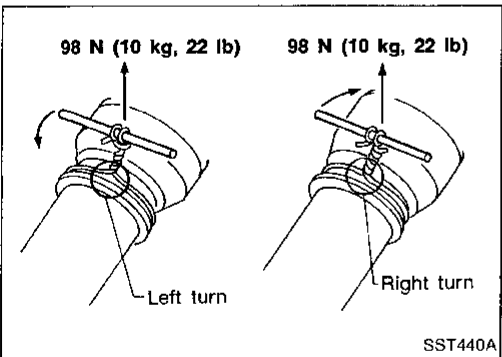

21. Install boot clamps.

- To install, wrap boot clamp around boot groove twice. Tighten clamp by twisting rings at both ends 4 to 4-1/2 turns with screwdriver while pulling with a force of approx. 98 N (10 kg, 22 lb).

- Twist boot clamp in the direction shown in figure at left.

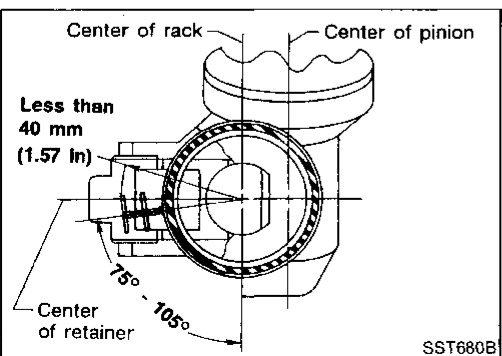

- Install boot clamps so they are behind the gear housing when it is attached to the vehicle. (This will prevent interference with other parts.)

POWER STEERING GEAR AND LINKAGE (Model PR24AC)

Assembly (Cont'd)

- After twisting boot clamp, bend twisted and diagonally so it does not contact boot.

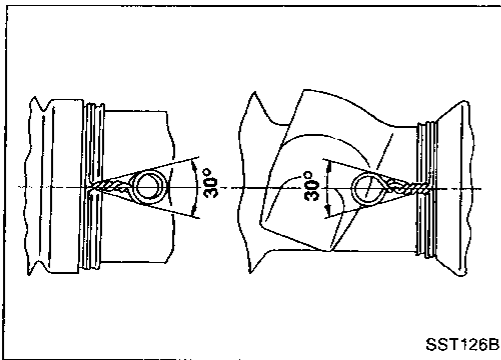

GI

MA

EM

LC

EF &
EC

FE

CL

MT

AT

FA

RA

BR

ST

BF

HA

EL

IDX

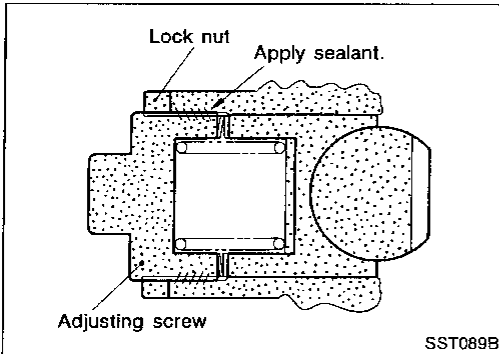

Adjustment

Adjust pinion rotating torque as follows:

1. Set rack to the neutral position without fluid in the gear.
2. Coat the adjusting screw with locking sealant and screw it in.
3. Lightly tighten lock nut.
4. Tighten adjusting screw to a torque of 4.9 to 5.9 N·m (50 to 60 kg-cm, 43 to 52 in-lb).
5. Loosen adjusting screw, then retighten it to 0.2 N·m (2 kg-cm, 1.7 in-lb).

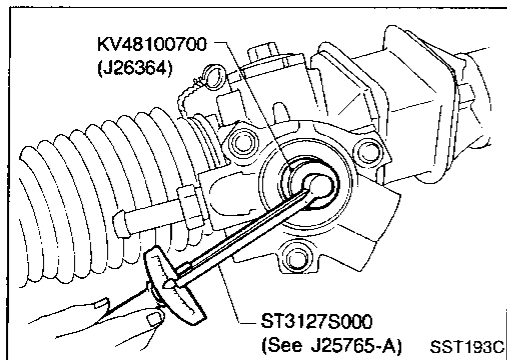

6. Move rack over its entire stroke several times.
7. Measure pinion rotating torque within the range of 180° from neutral position.
Stop the gear at the point of maximum torque.
8. Loosen adjusting screw, then retighten it to 4.9 N·m (50 kg-cm, 43 in-lb).
9. Loosen adjusting screw by 40° to 60°.

10. Prevent adjusting screw from turning, and tighten lock nut to specified torque.

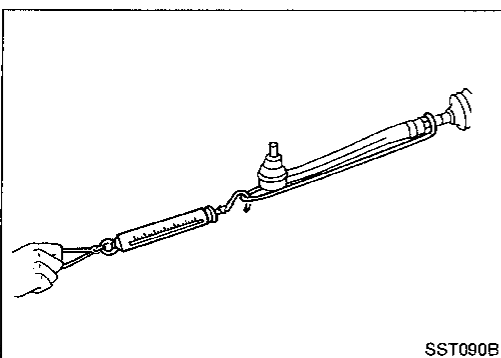

11. Check rack sliding force on vehicle as follows:
 - a. Install steering gear onto vehicle, but do not connect tie-rod to knuckle arm.
 - b. Connect all piping and fill with steering fluid.
 - c. Start engine and bleed air completely.
 - d. Disconnect steering column lower joint from the gear.
 - e. Keep engine at idle and make sure steering fluid has reached normal operating temperature.
 - f. While pulling tie-rod slowly in the ± 11.5 mm (± 0.453 in) range from the neutral position, make sure rack sliding force is within specification.

POWER STEERING GEAR AND LINKAGE (Model PR24AC)

Adjustment (Cont'd)

Rack sliding force:

147 - 245 N (15 - 25 kg, 33 - 55 lb)

- g. Check sliding force outside above range.

Rack sliding force:

Not more than 294 N (30 kg, 66 lb)

- If rack sliding force is not within specification, readjust by repeating adjustment procedure from the beginning.
- If rack sliding force is still out of specification after readjustment, gear assembly needs to be replaced.

POWER STEERING OIL PUMP

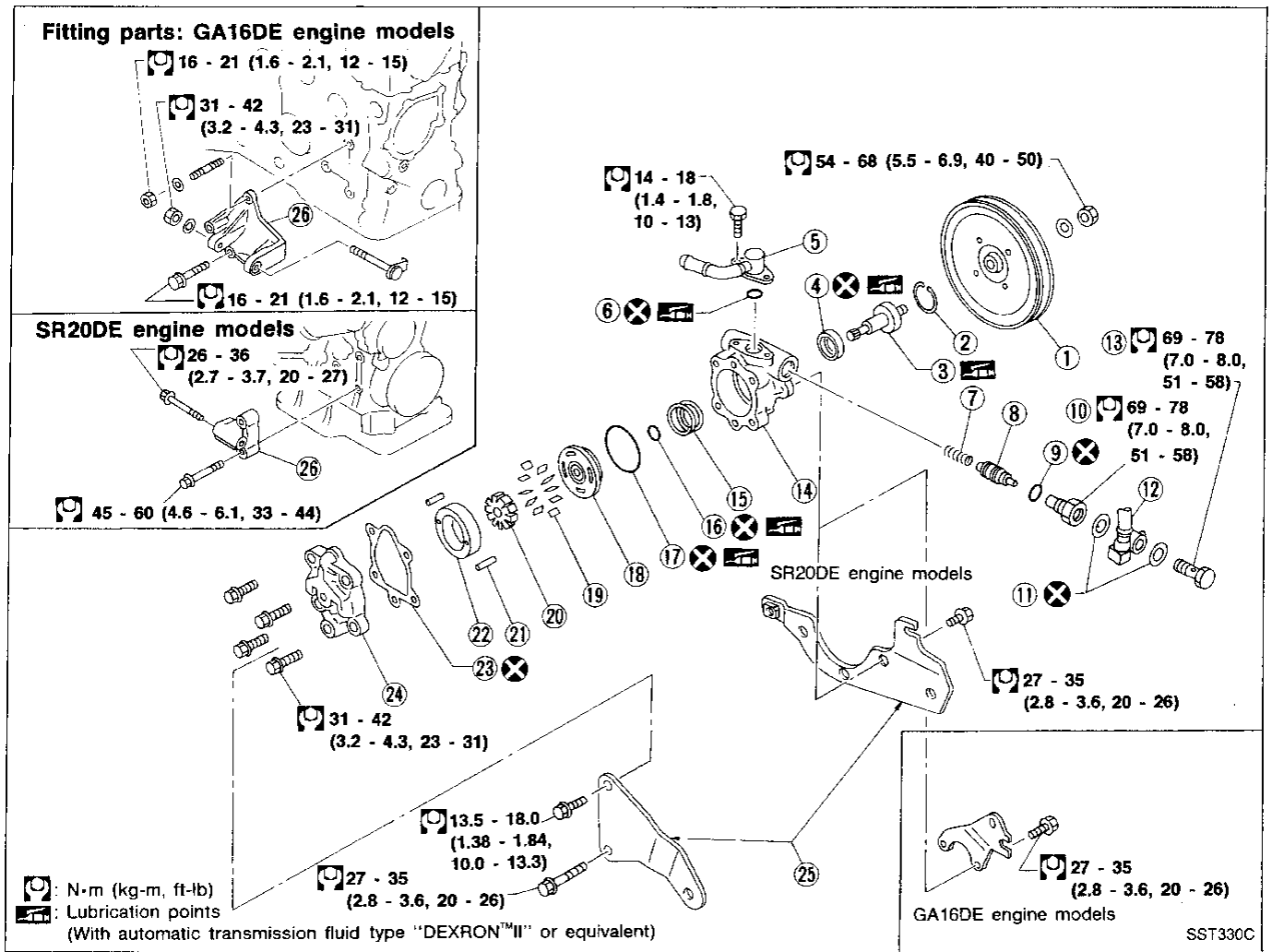

- | | | |
|-----------------|--------------------|-----------------------------------|
| ① Pulley | ⑩ Connector | ⑲ Vane |
| ② Snap ring | ⑪ Washer | ⑳ Rotor |
| ③ Drive shaft | ⑫ Joint | ㉑ Pin |
| ④ Oil seal | ⑬ Connector bolt | ㉒ Cam ring |
| ⑤ Suction pipe | ⑭ Front housing | ㉓ Gasket |
| ⑥ O-ring | ⑮ Spring | ㉔ Rear housing |
| ⑦ Spring | ⑯ O-ring | ㉕ Mounting bracket |
| ⑧ Control-valve | ⑰ O-ring | ㉖ Power steering oil pump bracket |
| ⑨ O-ring | ⑱ Front side plate | |

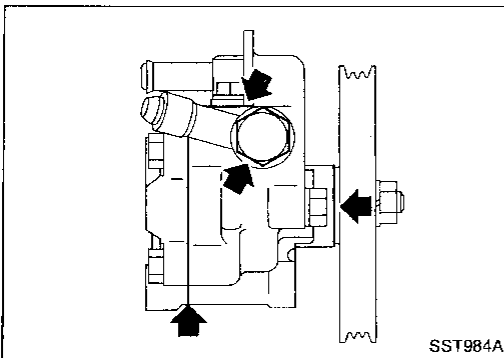

Pre-disassembly Inspection

Disassemble the power steering oil pump only if the following items are found.

- Oil leak from any point shown in the figure.
- Deformed or damaged pulley.

POWER STEERING OIL PUMP

Disassembly

CAUTION:

- Parts which can be disassembled are strictly limited. Never disassemble parts other than those specified.
- Disassemble in as clean a place as possible.
- Clean your hands before disassembly.
- Do not use rags; use nylon cloths or paper towels.
- Follow the procedures and cautions in the Service Manual.
- When disassembling and reassembling, do not let foreign matter enter or contact the parts.

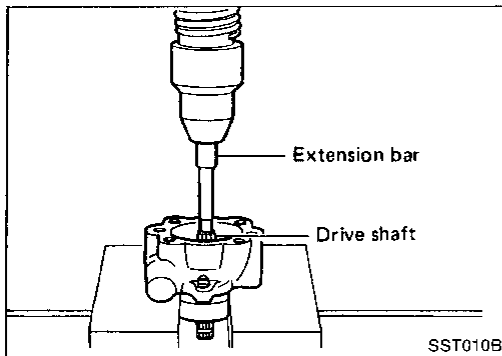

- Remove snap ring, then draw drive shaft out.
Be careful not to drop drive shaft.

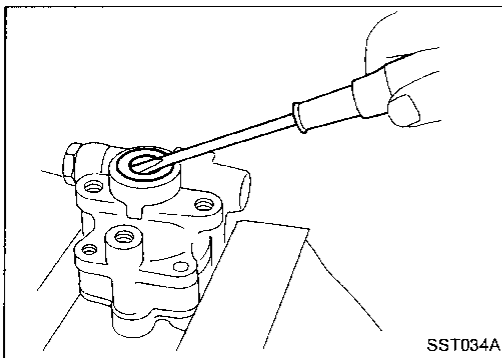

- Remove oil seal.
Be careful not to damage front housing.

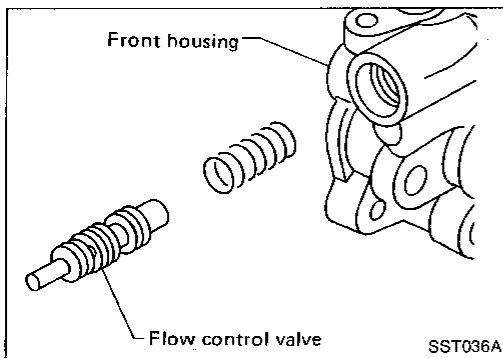

- Remove connector.
Be careful not to drop control valve.

Inspection

Inspect each component part for wear, deformation, scratches, and cracks. If damage is found, replace the part.

POWER STEERING OIL PUMP

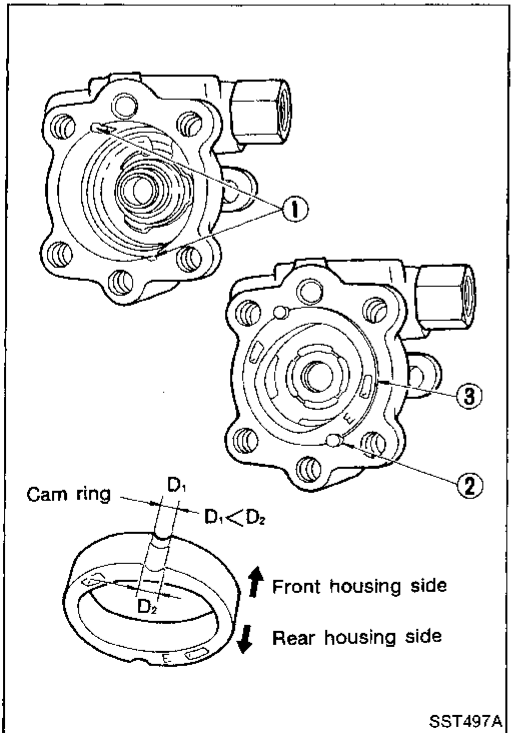
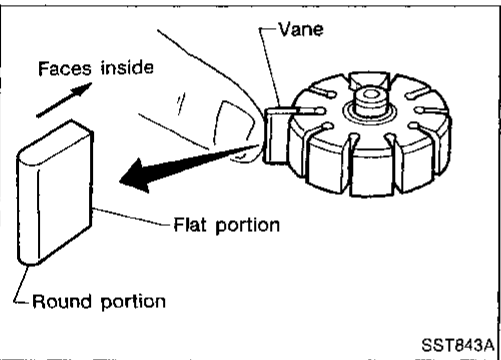
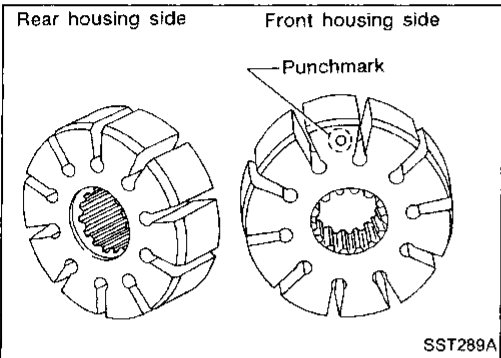
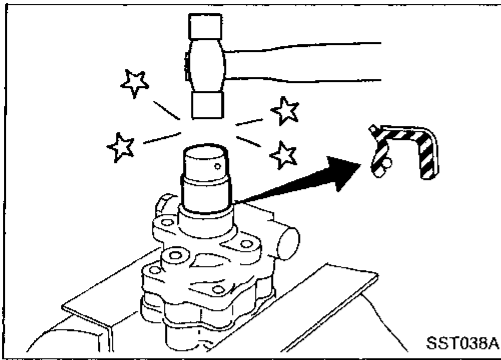

Assembly

Assemble oil pump, noting the following instructions.

- Make sure O-rings and oil seal are properly installed.
- Always install new O-rings and oil seal.
- Be careful of oil seal direction.
- Cam ring, rotor and vanes must be replaced as a set if necessary.
- Coat each part with ATF when assembling.

- Pay attention to the direction of rotor.

- When assembling vanes to rotor, rounded surfaces of vanes must face cam ring side.

- Insert pin ② into pin groove ① of front housing and front side plate. Then install cam ring ③ as shown at left.

GI

MA

EM

LC

EF &
EC

FE

CL

MT

AT

FA

RA

BR

ST

BF

HA

EL

IDX

General Specifications

Applied model	GA16DE STD	GA16DE	SR20DE
Steering model	Manual steering	Power steering	
Steering gear type	R24N	PR24AC	
Steering overall gear ratio	22.7	16.5	16.5
Turns of steering wheel (Lock to lock)	4.21	3.07	2.74
Steering column type	Collapsible, tilt		

Inspection and Adjustment

GENERAL

Steering wheel axial play mm (in)	0 (0)
Steering wheel play limit mm (in)	35 (1.38)
Maximum movement of gear housing mm (in)	± 2 (± 0.08)

STEERING COLUMN

Applied model	Without air bag	With air bag
Steering column length "L" mm (in)	533.2 - 534.8 (20.99 - 21.06)	536.2 - 537.8 (21.11 - 21.17)

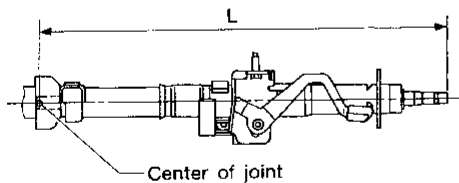

SST334C

STEERING GEAR AND LINKAGE

Steering gear type	R24N	PR24AC
Tie-rod outer ball joint Swinging force "A" at cotter pin hole N (kg, lb)	6.9 - 64.7 (0.7 - 6.6, 1.5 - 14.6)	
Rotating torque "B" N·m (kg·cm, in·lb)	0.3 - 2.9 (3 - 30, 2.6 - 26.0)	
Axial end play limit "C" mm (in)	Less than 0.5 (0.020)	
Tie-rod inner ball joint Swinging force*1 "A" N (kg, lb)	14.7 - 215.8 (1.5 - 22, 3.3 - 48.5)	
Axial end play limit "C" mm (in)	0 (0)	
Tie-rod standard length "L" mm (in)	186 (7.32)	186 (7.32)*2 194 (7.64)*3

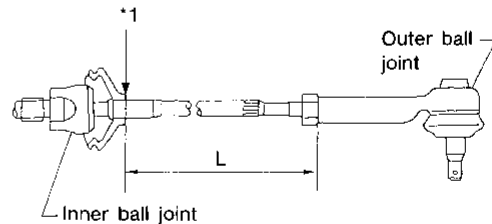

SST172CA

*1: Measuring point of swing force

*2: GA16DE engine models

*3: SR20DE engine models

SERVICE DATA AND SPECIFICATIONS (SDS)

Inspection and Adjustment (Cont'd)

STEERING GEAR AND LINKAGE (Cont'd)

Steering gear type	R24N	PR24AC
Rack stroke "L" mm (in)	73.5 (2.894)	73.5 (2.894)*1 65.5 (2.579)*2

*1: GA16DE engine models
*2: SR20DE engine models

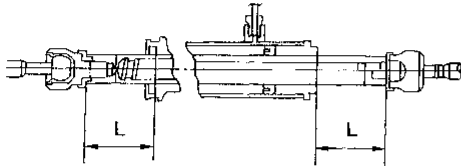

SST086B

Steering gear type	R24N	PR24AC
Retainer adjustment		
Adjusting screw		
Initial tightening torque N·m (kg-cm, in-lb)	9.8 (100, 87)	4.9 - 5.9 (50 - 60, 43 - 52)
Retightening torque after loosening N·m (kg-cm, in-lb)	—	0.2 (2, 1.7)
Tightening torque after gear has settled N·m (kg-cm, in-lb)	—	4.9 (50, 43)
Returning angle degree	Less than 60° [Within play of 0.1 mm (0.004 in)/15 N·m (1.5 kg-m, 11 ft-lb)]	40° - 60°
Pinion gear preload without gear oil N·m (kg-cm, in-lb)		
Within ±100° from the neutral position		
Average rotating torque	0.7 - 1.2 (7 - 12, 6.1 - 10.4)	—
Maximum torque deviation	0.3 (3, 2.6)	—
Except above range		
Maximum rotating torque	1.5 (15, 13)	—
Maximum torque deviation	0.5 (5, 4.3)	—

POWER STEERING

Steering gear type	PR24AC
Rack sliding force N (kg, lb)	
Under normal operating oil pressure	
Range within ±11.5 mm (±0.453 in) from the neutral position	147 - 245 (15 - 25, 33 - 55)
Except above range	Not more than 294 (30, 66)
Steering wheel turning force (Measured at one full turn from the neutral position) N (kg, lb)	39 (4, 9) or less
Fluid capacity (Approximate) ℓ (US qt, Imp qt)	1 (1-1/8, 7/8)
Oil pump maximum pressure kPa (kg/cm ² , psi)	7,649 - 8,238 (78 - 84, 1,109 - 1,194)

GI

MA

EM

LC

EF &
EC

FE

CL

MT

AT

FA

RA

BR

ST

BF

HA

EL