

TABLE OF CONTENTS

FOREWORD i

BODY COMPONENT PARTS

 Underbody Component Parts 1

 Body Component Parts 2

CORROSIVE PROTECTION

 Description 4

 Anti-Corrosive Wax 5

 Stone Guard Coat 6

BODY CONSTRUCTION

 Body Construction 7

BODY ALIGNMENT

 Body Center Marks 8

 Panel Parts Matching Marks 9

 Engine Compartment 10

 Underbody 12

 Passenger Compartment 14

 Rear Body 18

HANDLING PRECAUTIONS FOR PLASTICS

 Handling Precautions for Plastics 22

 Location of Plastic Parts 23

PRECAUTIONS

 Precautions in Repairing High Strength Steel (HSS) 26

© 1995 NISSAN MOTOR CORPORATION U.S.A.
All rights reserved. No part of this publication may
be reproduced in any form without the prior written
permission of Nissan.

FOREWORD

This Body Repair Information brochure contains information, instructions and procedures for repairing the body structure for the 1995 Sentra/200SX model. In order to achieve reliable repair work and ensure customer satisfaction, the technician should study this brochure and familiarize himself with appropriate sections before starting repair and rebuilding work.

This Body Repair brochure is prepared for use by technicians who are assumed to have a high level of skill and experience in repairing collision-damaged vehicles and also use modern servicing tools and equipment. It is not recommended that persons unfamiliar with body repair techniques attempt to repair collision-damaged vehicles by using this brochure.

Technicians are also required to read the 1995 Sentra/200SX Service Manual and Body Repair Manual (Fundamentals) in order to ensure that the original functions and quality of the vehicle can be maintained. The Body Repair Manual (Fundamentals) contains additional information, including cautions and warnings, that are not included in this brochure. Technicians should refer to both manuals to ensure proper repairs.

Please note that these manuals are prepared for worldwide usage, and as such, certain procedures might not apply in some regions or countries. In the USA, it is recommended that a M.I.G. welder be used by a trained technician to weld structural body parts.

All information in this brochure is based on the latest product information at the time of publication. The right is reserved to make changes in specifications and methods at any time without notice.

UNDERBODY COMPONENT PARTS

4 Door and 2 Door

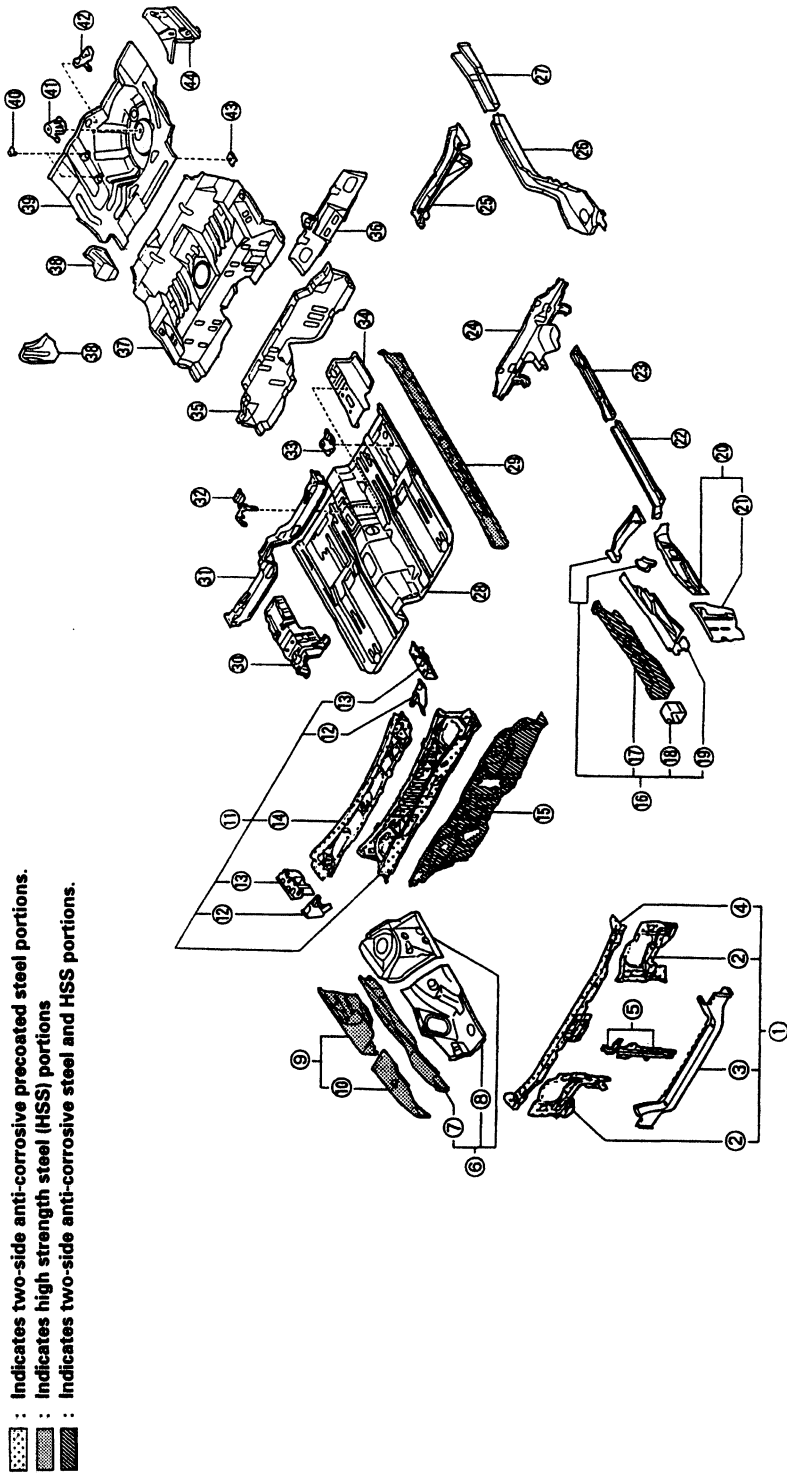

-  : Indicates two-side anti-corrosive pre-coated steel portions.
-  : Indicates high strength steel (HSS) portions
-  : Indicates two-side anti-corrosive steel and HSS portions.

- 1 Radiator core support assembly
- 2 Side radiator core support
- 3 Lower radiator core support
- 4 Upper radiator core support
- 5 Hood lock stay
- 6 Hoodedge assembly (R.H. & L.H.)
- 7 Upper hoodedge (R.H. & L.H.)
- 8 Front lower hoodedge (R.H. & L.H.)
- 9 Hoodedge reinforcement (R.H. & L.H.)
- 10 Front hoodedge reinforcement (R.H. & L.H.)
- 11 Air box assembly
- 12 Side cowl top brace
- 13 Side cowl top
- 14 Cowl top
- 15 Lower dash
- 16 Front side member assembly (R.H. & L.H.)
- 17 Front side member (R.H. & L.H.)
- 18 Bumper stay reinforcement (R.H. & L.H.)
- 19 Front side member reinforcement
- 20 Front side member closing plate (R.H. & L.H.)
- 21 Front side member front closing plate (R.H. & L.H.)
- 22 Front side member center extension (R.H. & L.H.)
- 23 Front side member rear extension (R.H. & L.H.)
- 24 Rear seat crossmember
- 25 Rear crossmember
- 26 Rear side member (R.H. & L.H.)
- 27 Rear side member extension (R.H. & L.H.)
- 28 Front floor
- 29 Inner sill (R.H. & L.H.)
- 30 Transmission control reinforcement
- 31 2nd crossmember assembly
- 32 Sensor bracket assembly
- 33 Outer front seat mounting bracket (R.H. & L.H.)
- 34 Hand brake & seat belt reinforcement
- 35 Rear seat crossmember assembly.
- 36 Rear floor anchor belt reinforcement (R.H. & L.H.)
- 37 Rear floor front (R.H. & L.H.)
- 38 Rear seat back support
- 39 Rear floor rear
- 40 Plate
- 41 Spare wheel clamp bracket
- 42 Muffler mounting bracket
- 43 Plate
- 44 Rear floor side

BODY COMPONENT PARTS

4 Door

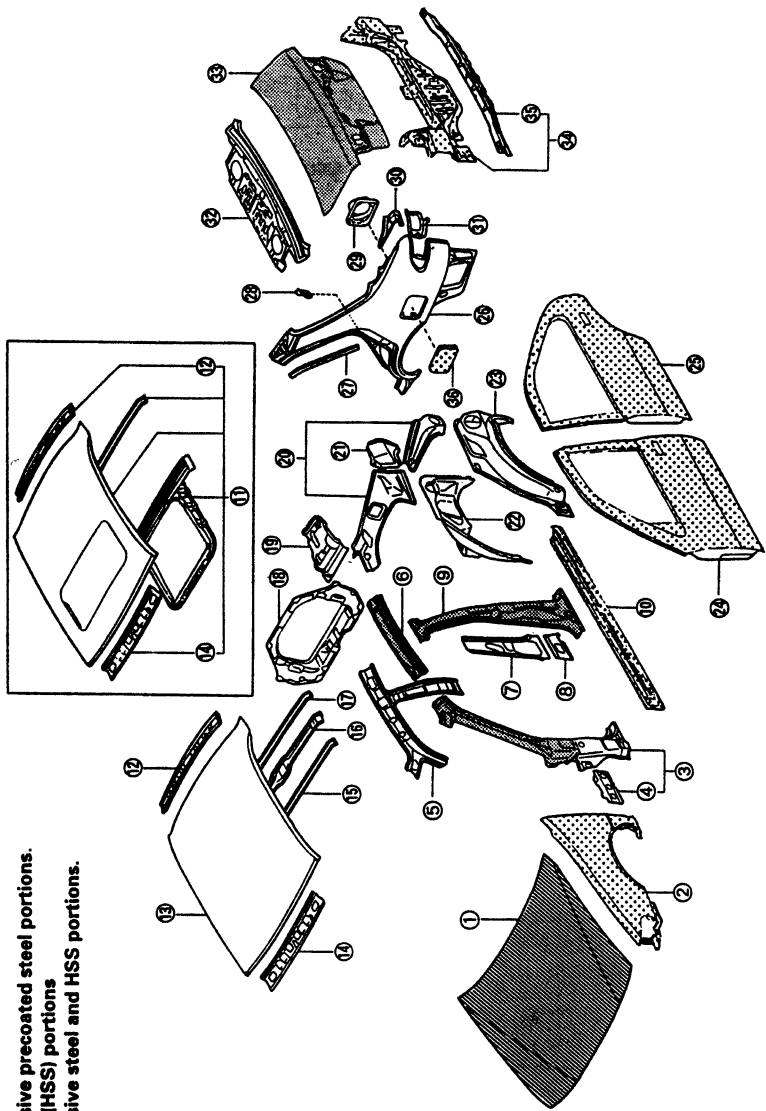

 : Indicates two-side anti-corrosive pre-coated steel portions.
 : Indicates high strength steel (HSS) portions
 : Indicates two-side anti-corrosive steel and HSS portions.

- 1 Hood
- 2 Front fender (R.H. & L.H.)
- 3 Front side assembly (R.H. & L.H.)
- 4 Lower front pillar reinforcement
- 5 Inner side roof rail (R.H. & L.H.)
- 6 Outer side roof rail (R.H. & L.H.)
- 7 Inner center pillar upper (R.H. & L.H.)
- 8 Inner center pillar lower (R.H. & L.H.)
- 9 Outer center pillar (R.H. & L.H.)
- 10 Outer sill (R.H. & L.H.)
- 11 Roof assembly
- 12 Rear roof rail
- 13 Roof
- 14 Front roof rail
- 15 No.1 roof bow
- 16 No.2 roof bow

- 17 No.3 roof bow
- 18 Rear seat back support
- 19 Side parcel shelf (R.H. & L.H.)
- 20 Inner rear pillar upper (R.H. & L.H.)
- 21 Inner rear pillar lower (R.H. & L.H.)
- 22 Inner rear wheelhouse (R.H. & L.H.)
- 23 Outer rear wheelhouse (R.H. & L.H.)
- 24 Front door assembly (R.H. & L.H.)
- 25 Rear door assembly (R.H. & L.H.)
- 26 Rear fender (R.H. & L.H.)
- 27 Rear fender drip (R.H. & L.H.)
- 28 Striker tapping retainer (R.H. & L.H.)
- 29 Filler lid base
- 30 Rear fender corner (R.H. & L.H.)
- 31 Rear combination lamp base (R.H. & L.H.)
- 32 Parcel shelf with rear waist

- 33 Trunk lid
- 34 Rear panel
- 35 Rear bumper retainer
- 36 Fuel filler lid

BODY COMPONENT PARTS

2 Door

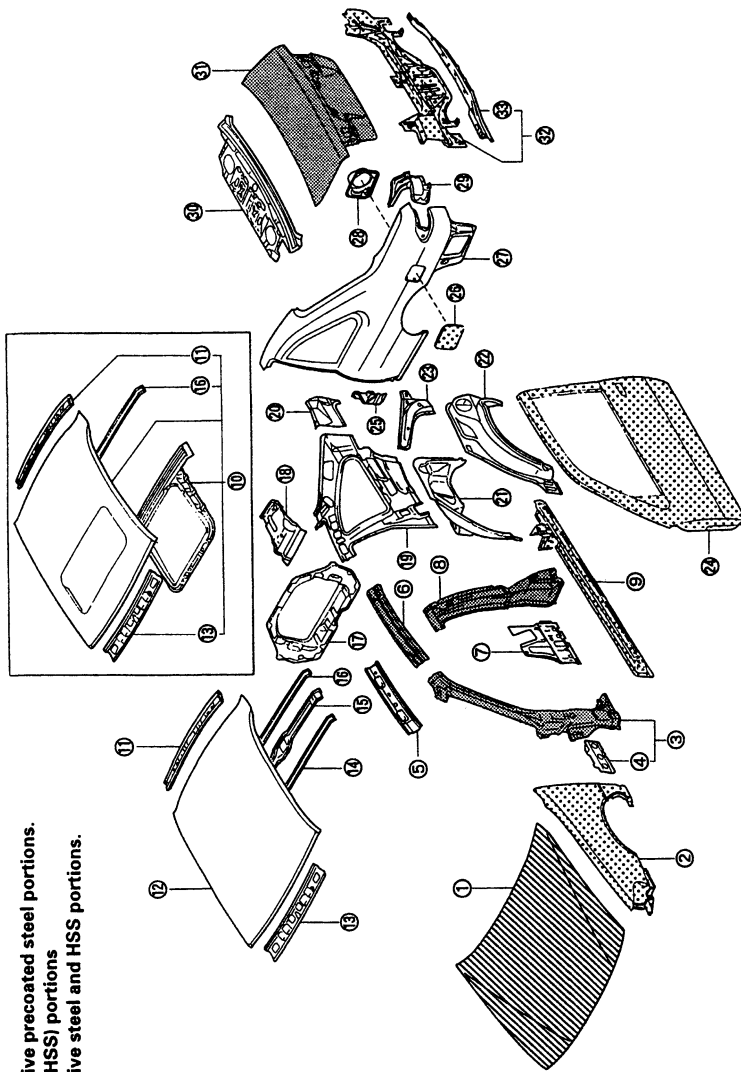

 : Indicates two-side anti-corrosive pre-coated steel portions.
 : Indicates high strength steel (HSS) portions
 : Indicates two-side anti-corrosive steel and HSS portions.

- 1 Hood
- 2 Front fender (R.H. & L.H.)
- 3 Front side assembly (R.H. & L.H.)
- 4 Lower front pillar reinforcement (R.H. & L.H.)
- 5 Inner side roof rail (R.H. & L.H.)
- 6 Outer side roof rail (R.H. & L.H.)
- 7 Outer sill reinforcement (R.H. & L.H.)
- 8 Lock pillar outer reinforcement (R.H. & L.H.)
- 9 Outer sill (R.H. & L.H.)
- 10 Roof assembly
- 11 Rear roof rail
- 12 Roof
- 13 Front roof rail
- 14 No.1 roof bow
- 15 No.2 roof bow
- 16 No.3 roof bow
- 17 Rear seat back support
- 18 Side parcel shelf (R.H. & L.H.)
- 19 Inner rear pillar upper (R.H. & L.H.)
- 20 Inner rear pillar lower (R.H. & L.H.)
- 21 Inner rear wheelhouse (R.H. & L.H.)
- 22 Outer rear wheelhouse (R.H. & L.H.)
- 23 Rear pillar reinforcement (R.H. & L.H.)
- 24 Front door assembly (R.H. & L.H.)
- 25 Striker tapping retainer (R.H. & L.H.)
- 26 Fuel filler lid
- 27 Rear fender (R.H. & L.H.)
- 28 Filler lid base
- 29 Rear combination lamp base (R.H. & L.H.)
- 30 Parcel shell with rear waist
- 31 Trunk lid
- 32 Rear panel
- 33 Rear bumper retainer

DESCRIPTION

In order to provide improved corrosion prevention, the following anti-corrosive measures have been implemented in our production plants. When repairing or replacing body panels, it is necessary to use these same anti-corrosive measures.

ANTI-CORROSIVE PRECOATED STEEL (DURASTEEL)

In order to improve repairability and corrosion resistance, a new type of anti-corrosive pre-coated steel sheets have been adopted taking the place of conventional zinc-coated steel sheets.

This durasteel is electroplated, zinc-nickel alloy under organic film, which provides excellent corrosion resistance.

Durasteel is classified as either one-side pre-coated steel or two-side pre-coated steel. The two-side pre-coated steel provides excellent corrosion resistance.

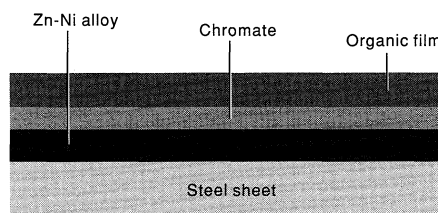

One-side pre-coated

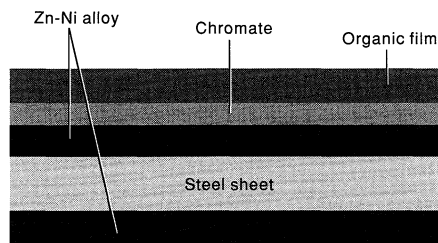

OUTSIDE
Two-side pre-coated

Nissan Genuine Service Parts are fabricated from durasteel sheets. Therefore, it is recommended that GENUINE NISSAN PARTS or equivalent be used for panel replacement to maintain the anti-corrosive performance built into the vehicle at the factory.

PHOSPHATE COATING TREATMENT AND CATIONIC ELECTRODEPOSITION PRIMER

A phosphate coating treatment and a cationic electrodeposition primer, which provide an excellent anti-corrosion effect, are employed on all body components.

Caution:

Confine paint removal in the welding operation to the absolute minimum.

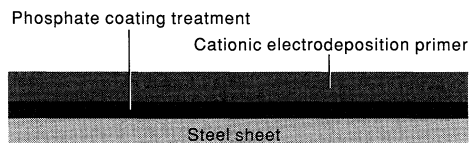

Nissan Genuine Service Parts also are treated in the same manner. Therefore, it is recommended that GENUINE NISSAN PARTS or equivalent be used for panel replacement to maintain anti-corrosive performance built into the vehicle at the factory.

ANTI-CORROSIVE WAX

In order to improve corrosion resistance, anti-corrosive wax is applied inside the body sill and inside other closed sections. Accordingly, when replacing these parts, be sure to apply anti-corrosive wax to the appropriate areas of the new parts. Select an excellent anti-corrosive wax which will penetrate after application and has a long shelf life.

 : INDICATES ANTI-CORROSIVE WAX COATED PORTIONS

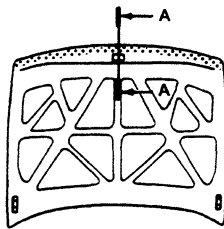

Hood

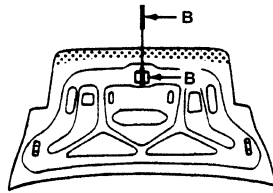

Trunk lid

Anti corrosive sealant along the hem.

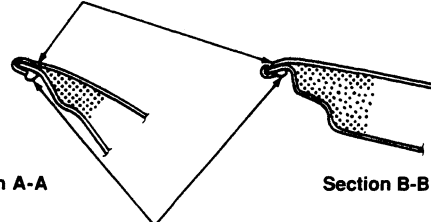

Section A-A

Section B-B

Paint sealant along the hem.

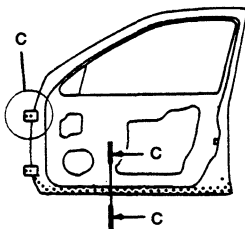

Front door

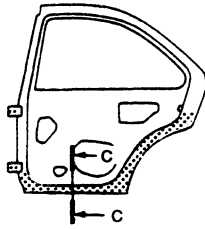

Rear door

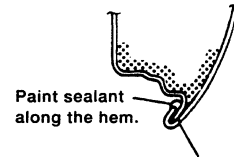

Paint sealant along the hem.

Anti-corrosive sealant along the hem.

Section C-C

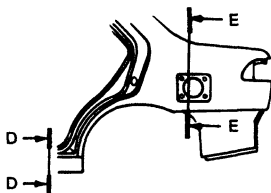

Rear fender

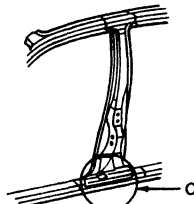

Center pillar



Section E-E

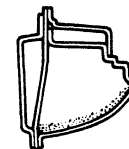

Section D-D

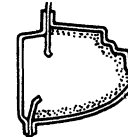

Section C

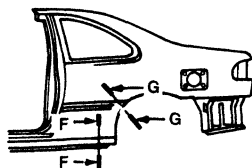

Rear fender

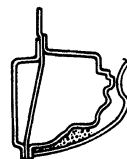

Section F-F



Section G-G

STONE GUARD COAT

In order to prevent damage caused by stones, the lower outer body panels (fender, door, etc.) have an additional layer of Stone Guard Coat over the ED primer coating. Thus, when replacing or repairing these panels, apply undercoat to the same portions as before. Use a coat which is rust preventive, durable, shock-resistant and has a long shelf life.

 :Indicates stone guard coated portion.

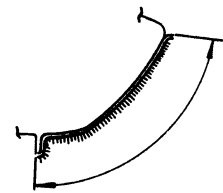
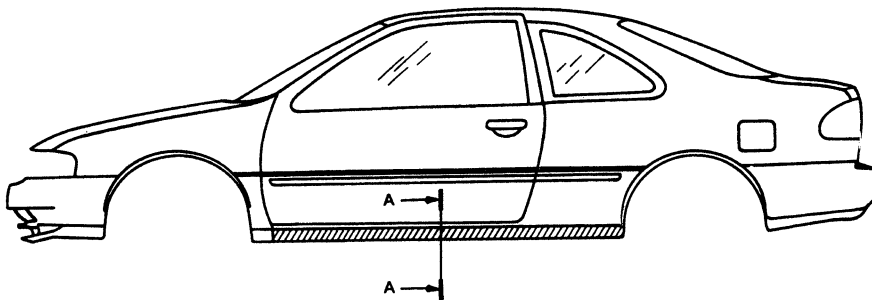

Section A-A

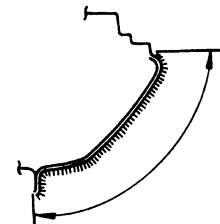
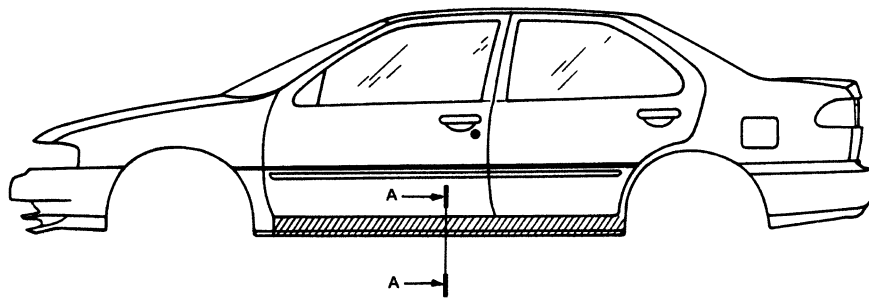

Section A-A

BODY CONSTRUCTION

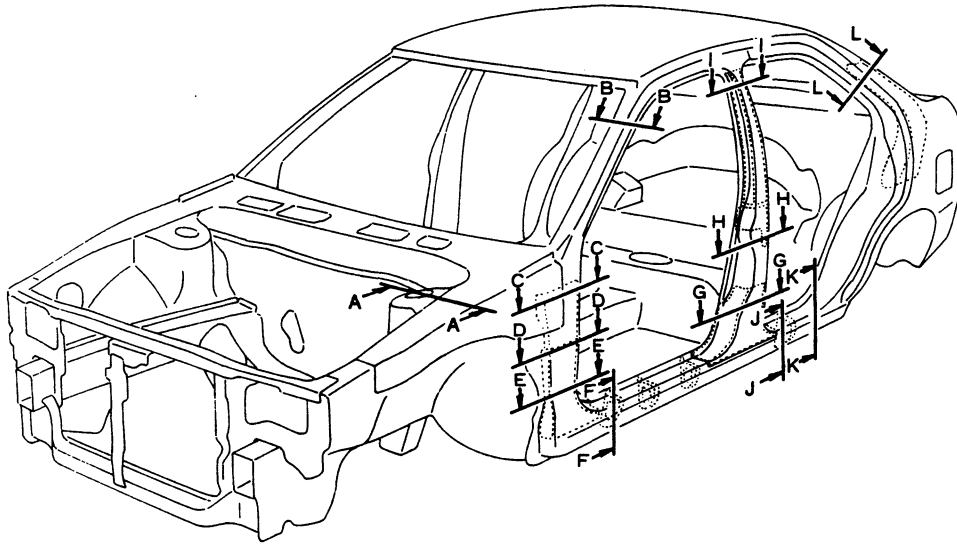

Section A-A	Section B-B	Section C-C	Section D-D
Section E-E	Section F-F	Section G-G	Section H-H
Section I-I	Section J-J	Section K-K	Section L-L

BODY CENTER MARKS

Mark has been placed on each part of the body to indicate the vehicle center. When repairing parts damaged in an accident which might affect the vehicle frame (members, pillars, etc.) more accurate, effective repair will be possible by using these marks together with body alignment data.

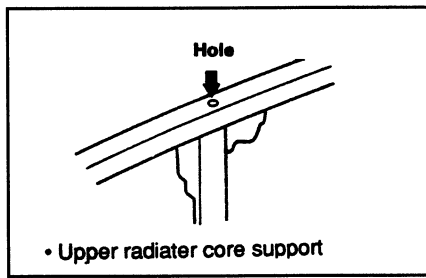

Portion A

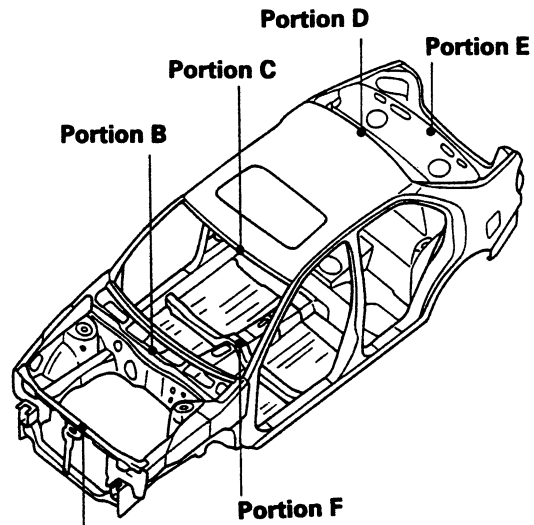

Portion A

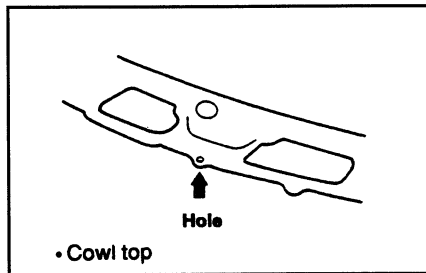

Portion B

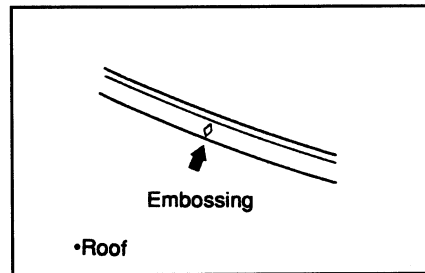

Portion C (Front, center)
Portion D (Rear, center)

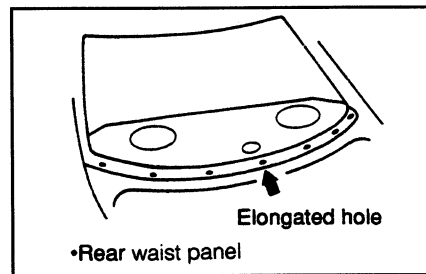

Portion E

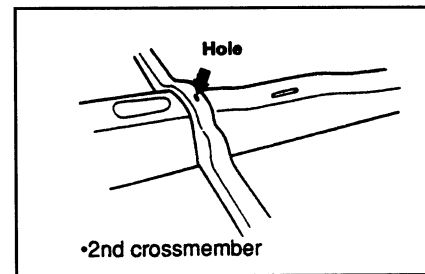

Portion F

PANEL PARTS MATCHING MARKS

(2) Side

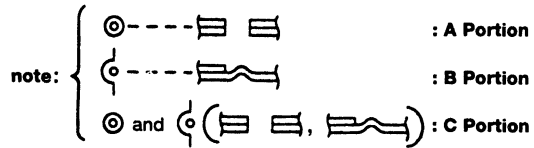
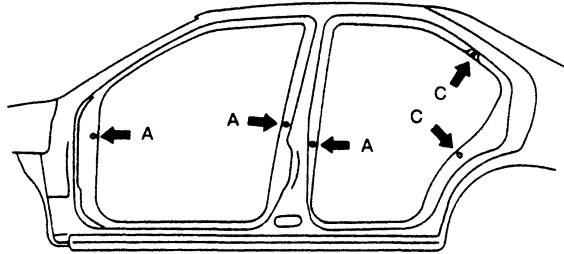

(1) Front

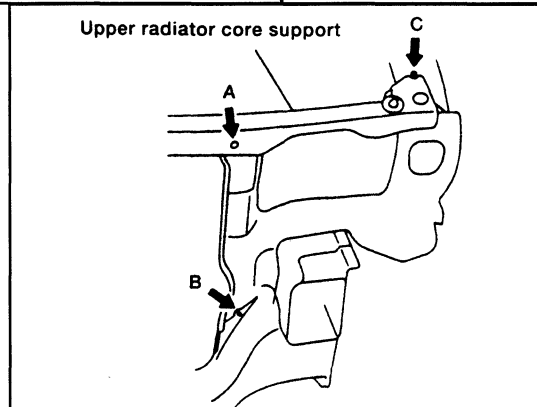
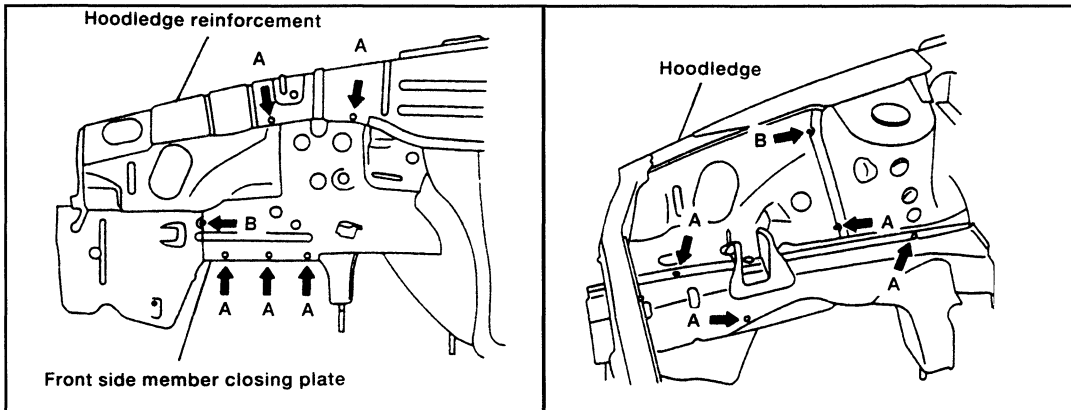

ENGINE COMPARTMENT

- All dimensions indicated in figures are actual ones.
- When using a tracking gauge, adjust both pointers to equal length. Then check the pointers and gauge itself to make sure there is no free play.
- When a measuring tape is used, check to be sure there is no elongation, twisting or bending.
- Measurements should be taken at the center of the mounting holes.
- An asterisk (*) following the value at the measuring point indicates that the measuring point on the other side is symmetrically the same value.
- The coordinates of the measurement points are the distances measured from the standard line of "X", "Y" and "Z".

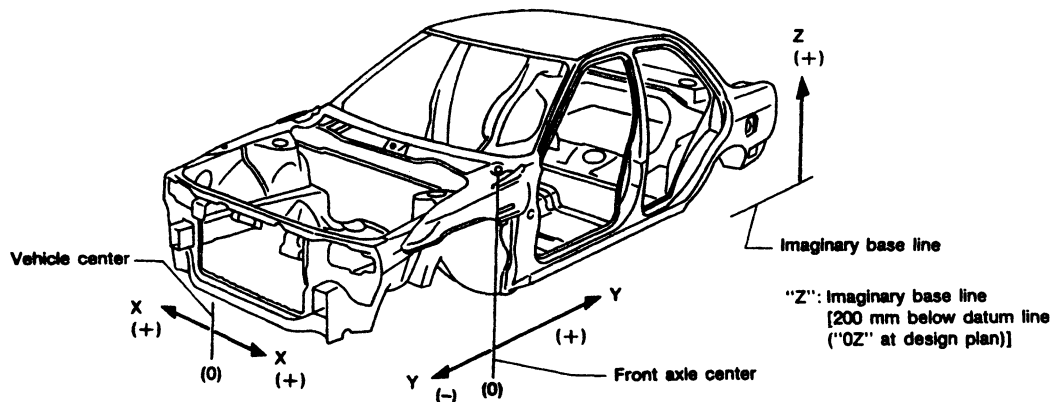

MEASUREMENT

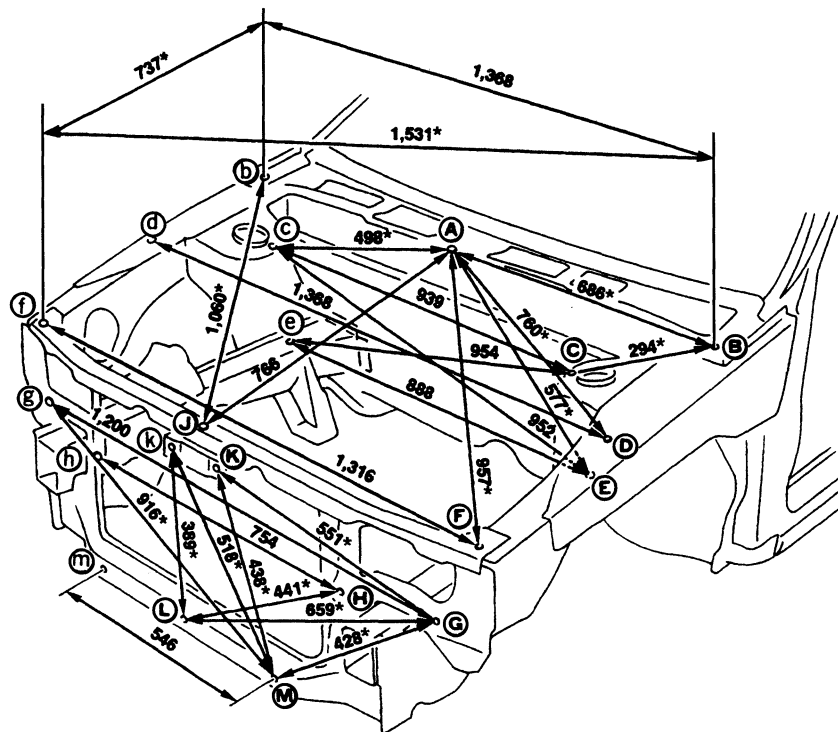

Unit: mm

ENGINE COMPARTMENT

MEASUREMENT POINTS

Unit: mm

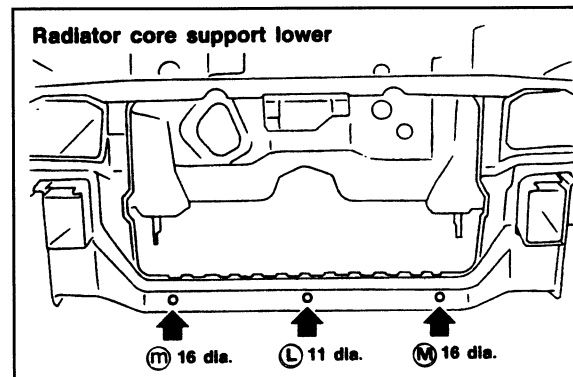
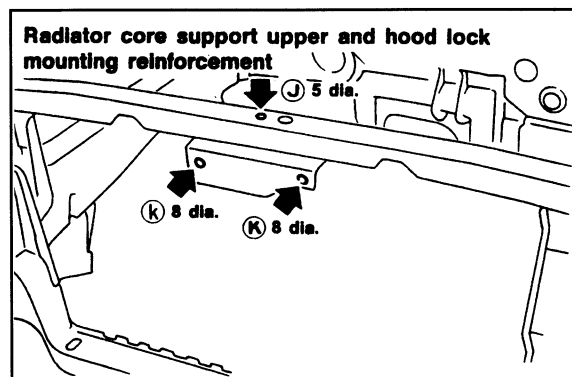
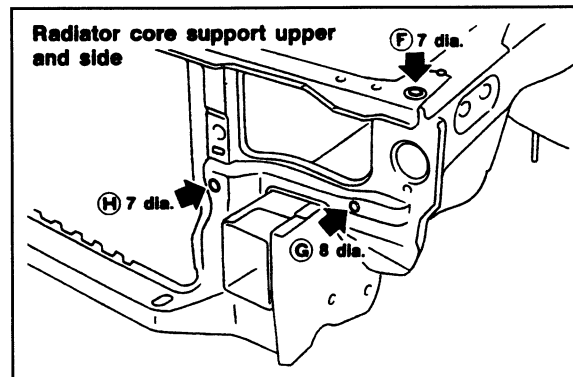
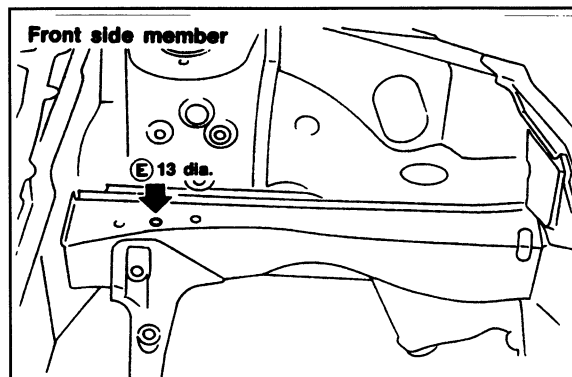
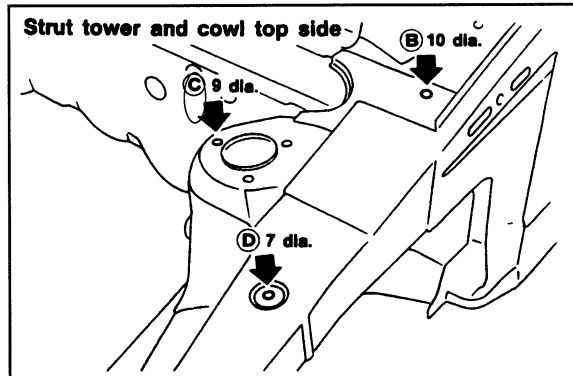
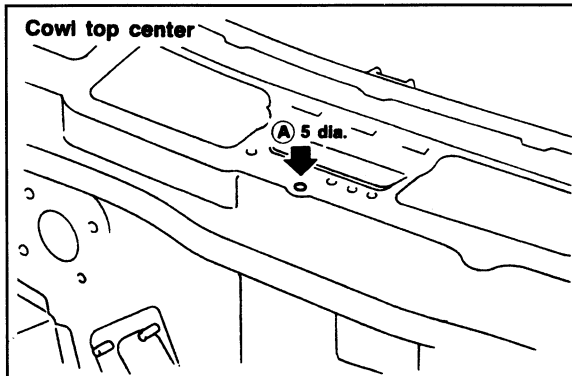

UNDERBODY

MEASUREMENT POINTS

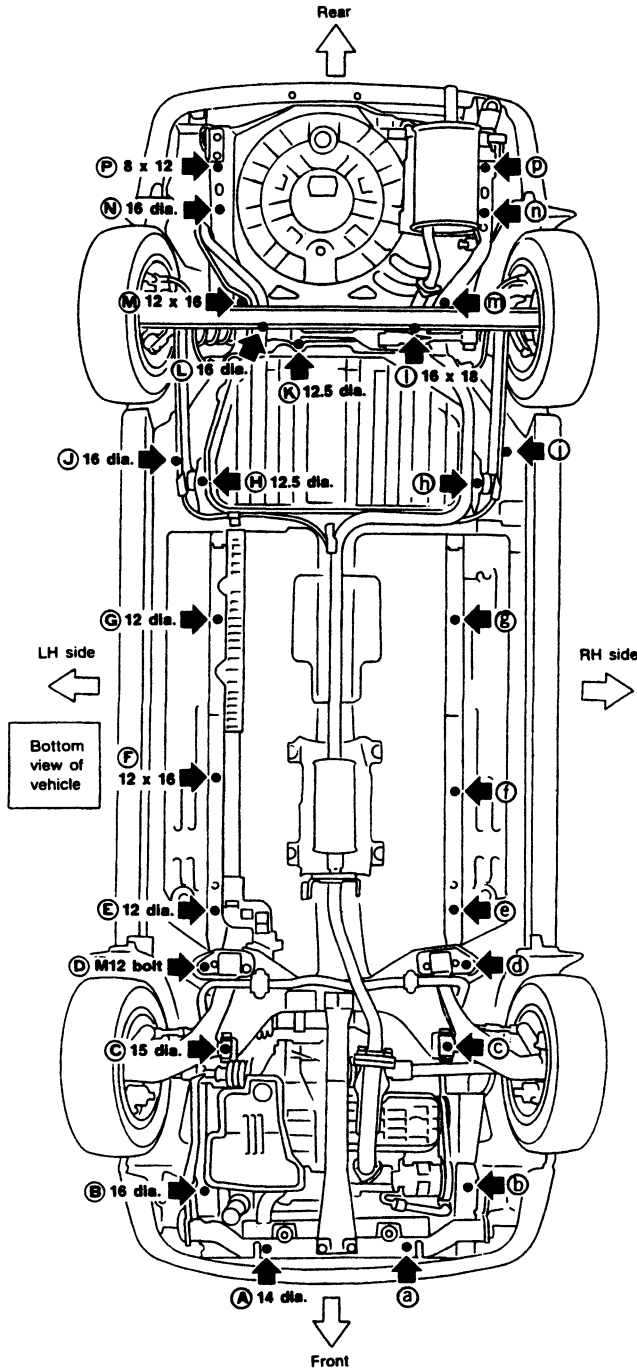

Front coordinates:	Rear coordinates:
(A), (a)	(G), (g)
X : 250	X : 393.5
Y : -632	Y : 1,460
Z : 224.8	Z : 126.9
(B), (b)	(H), (h)
X : 492	X : 572
Y : -450	Y : 1,940
Z : 355	Z : 200
(C), (c)	(J), (j)
X : 352.7	X : 600
Y : 69	Y : 2,035
Z : 240	Z : 235.2
(D), (d)	(K), (k)
X : 432	X : 150
Y : 336	Y : 2,467.9
Z : 128	Z : 241
(E), (e)	(L), (l)
X : 395	X : 300
Y : 515	Y : 2,480
Z : 129.2	Z : 381.8
(F), (f)	(I), (i)
X : 395	X : 300
Y : 950	Y : 2,480
Z : 129.2	Z : 405.8
(I), (i)	(M), (m)
X : 395	X : 393
Y : 900	Y : 2,560
Z : 129.2	Z : 365
	(N), (n)
	X : 470
	Y : 2,911
	Z : 339.6
	(O), (o)
	X : 539
	Y : 2,911
	Z : 339.6
	(P), (p)
	X : 475
	Y : 3,082
	Z : 335.8
	(Q), (q)
	X : 542
	Y : 3,082
	Z : 335.8

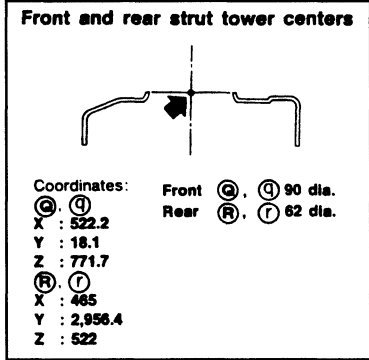

Unit: mm

PASSENGER COMPARTMENT

MEASUREMENT

4 Door

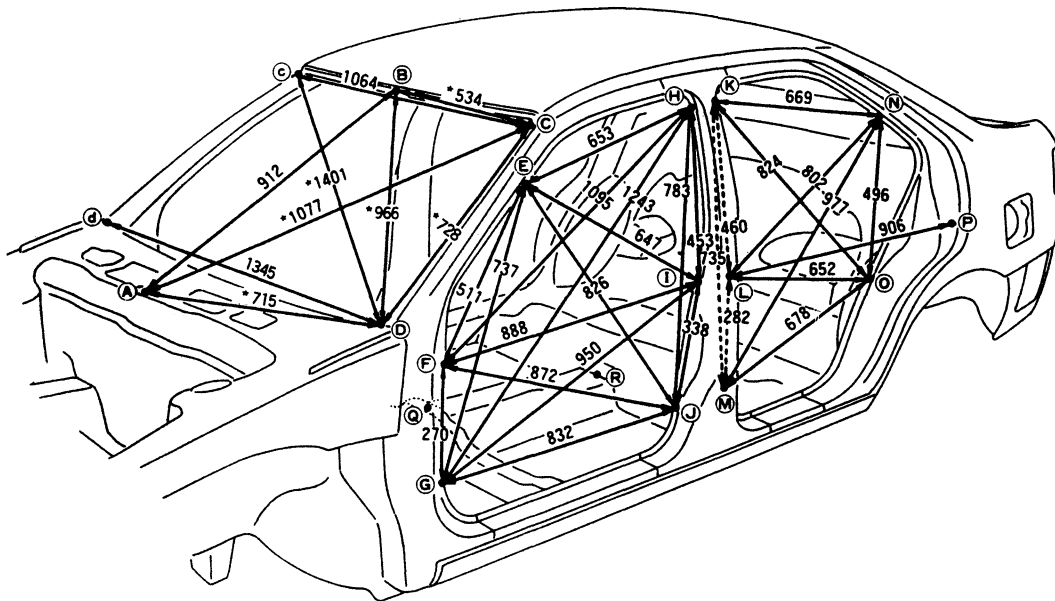

Unit : mm

Note: Figures indicated only on one side show symmetrically identical dimensions on the left and right sides of the vehicle.

Points	Dimensions
E~e	1228
F~f	1374
G~g	1366
H~h	1159
I~i	1387
J~j	1367
K~k	1156
L~l	1385
M~m	1370
N~n	1274

Points	Dimensions
O~o	1364
P~p	1598
Q~E	989
Q~F	918
Q~H	1156
Q~I	917
R~K	1097
R~L	856
R~N	1214
R~O	928

PASSENGER COMPARTMENT

MEASUREMENT POINTS

4 Door

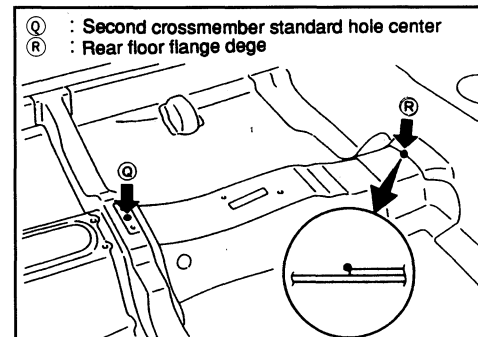
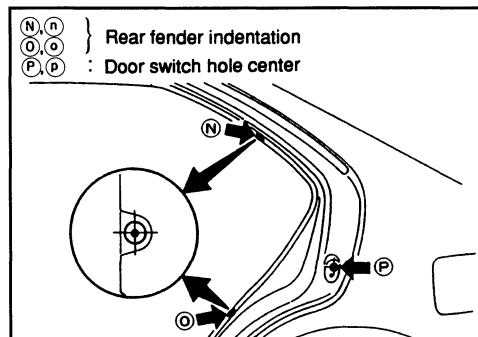
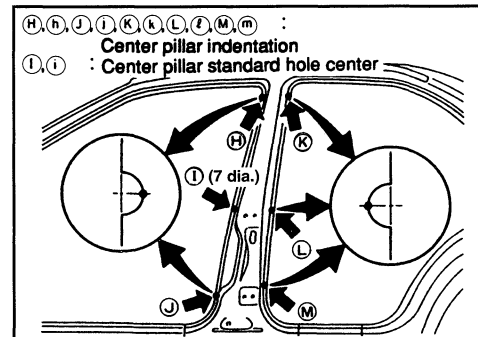
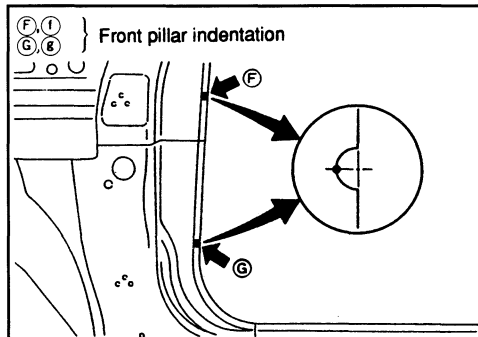
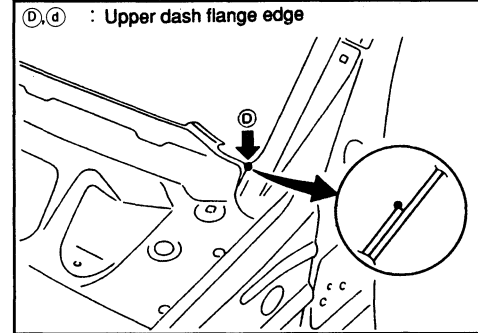
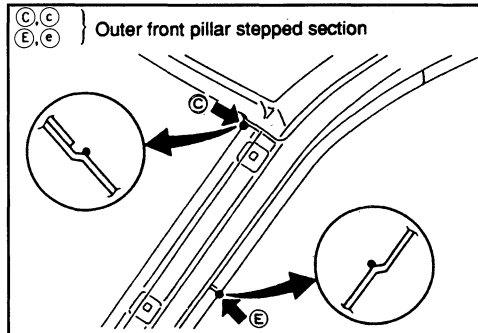
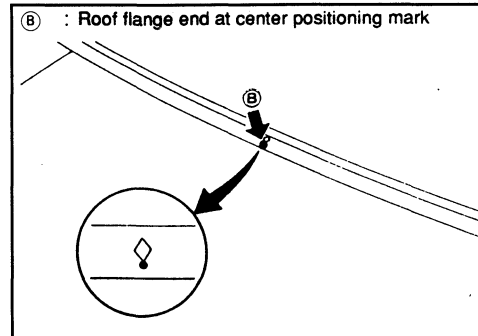
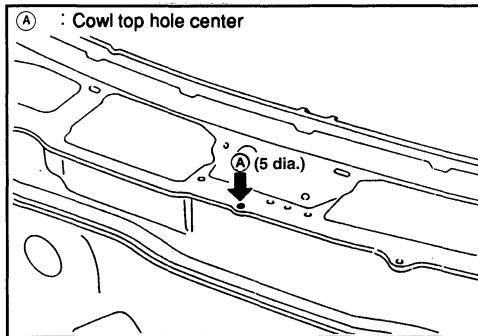

Unit: mm

PASSENGER COMPARTMENT

MEASUREMENT

2 Door

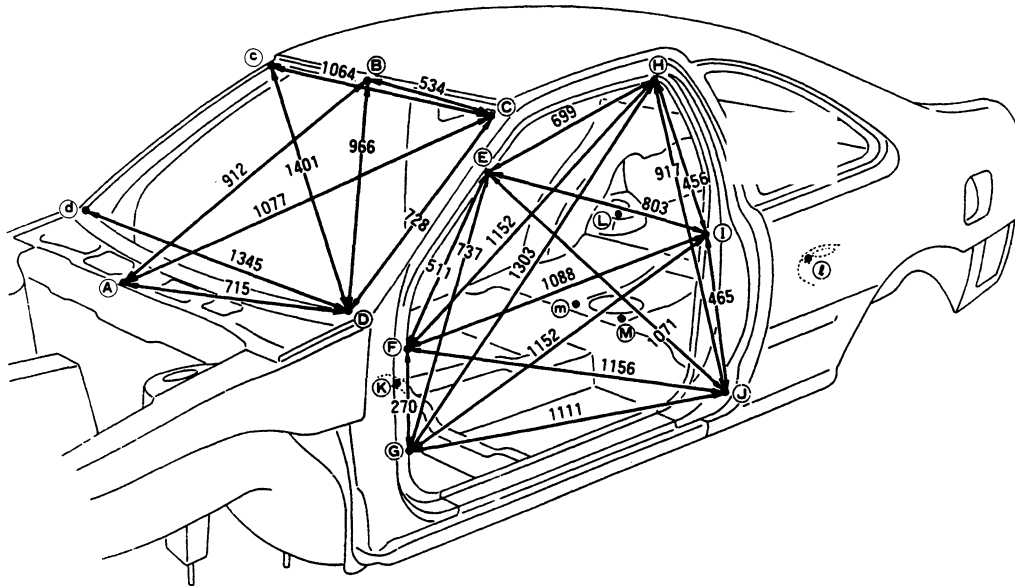

Unit : mm

Note: Figures indicated only on one side show symmetrically identical dimensions on the left and right sides of the vehicle.

Points	Dimensions
E~e	1228
F~f	1374
G~g	1366
H~h	1099
I~i	1388
J~j	1558
K~k	989

Points	Dimensions
K~F	918
K~C	1044
M~H	1015
M~I	770
M~L	655
M~I	777

PASSENGER COMPARTMENT

MEASUREMENT POINTS

2 Door

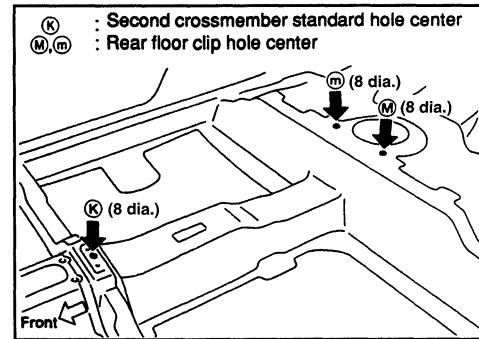
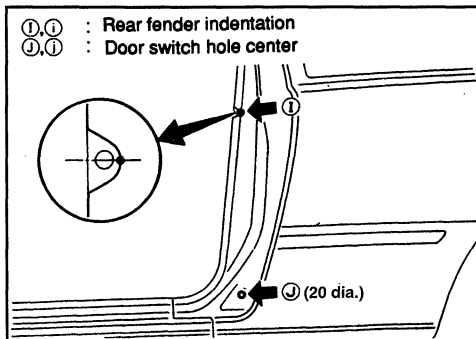
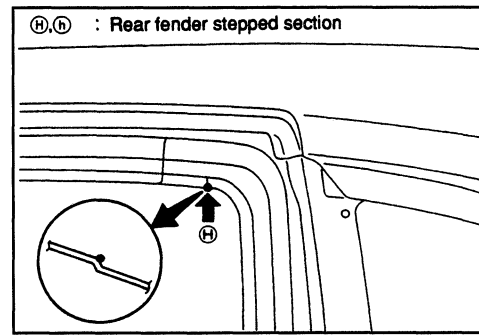
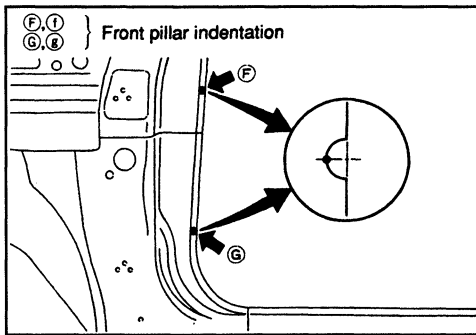
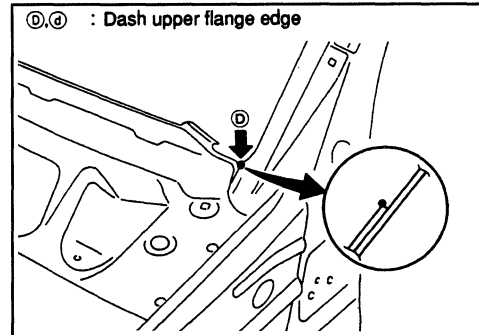
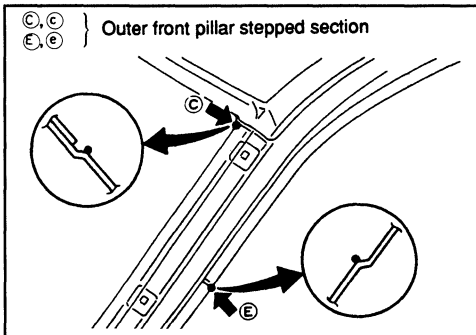
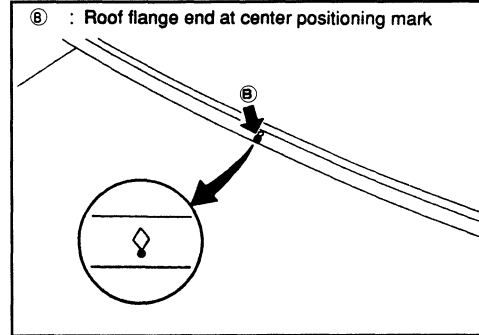
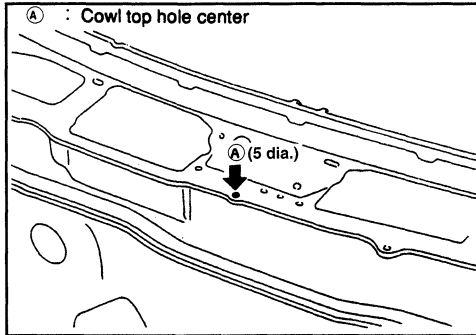

Unit: mm

REAR BODY

MEASUREMENT

4 Door

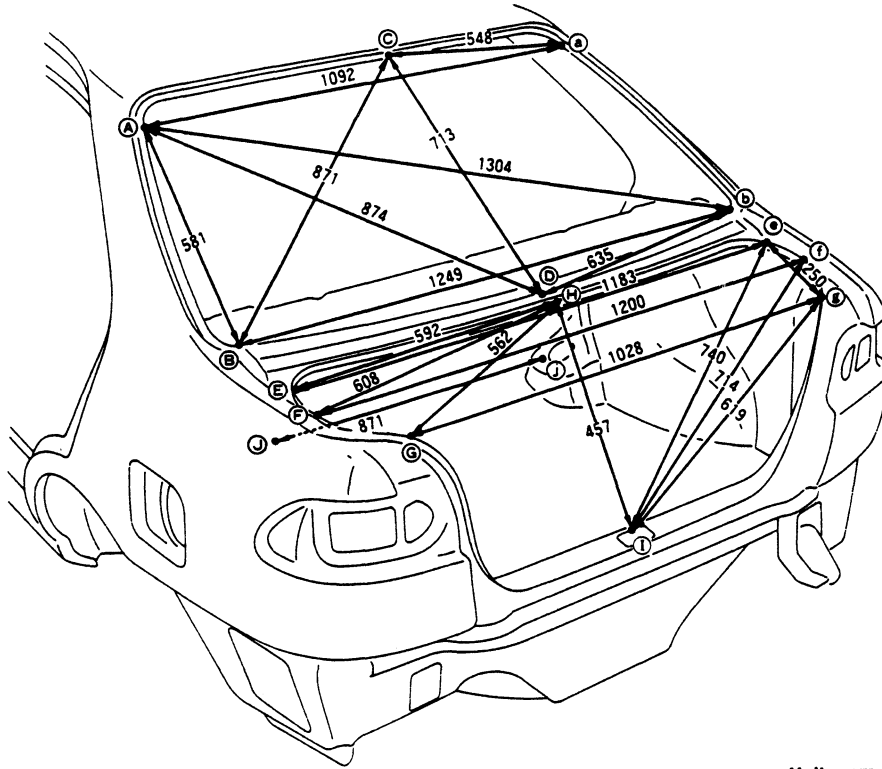

Unit : mm

Points	Dimensions
E~F	113
E~I	1197
E~G	1131
I~J	936

REAR BODY

MEASUREMENT POINTS

4 Door

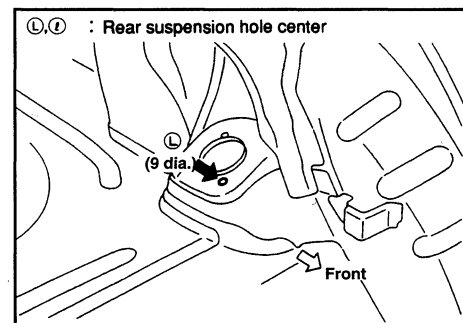
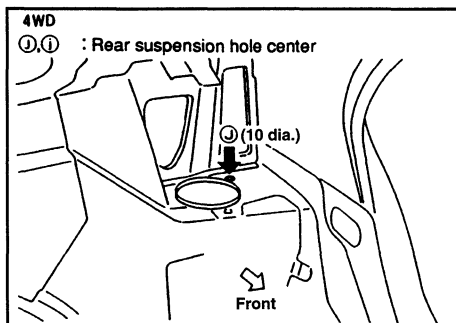
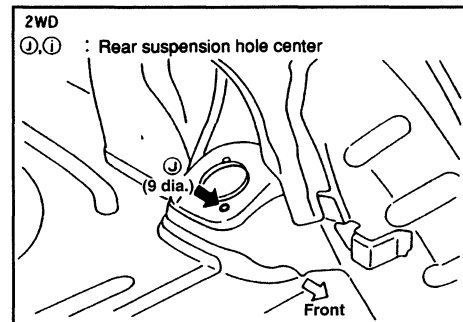
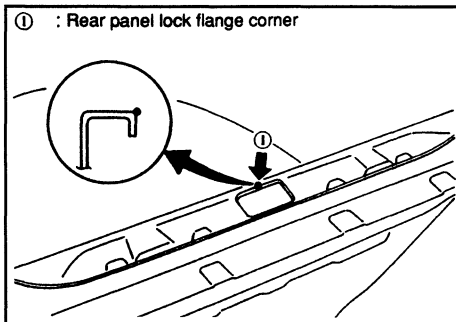
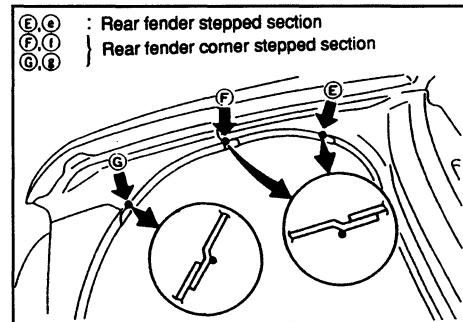
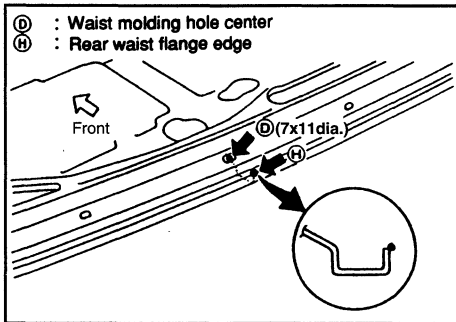
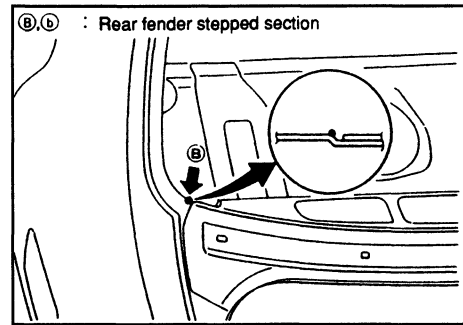
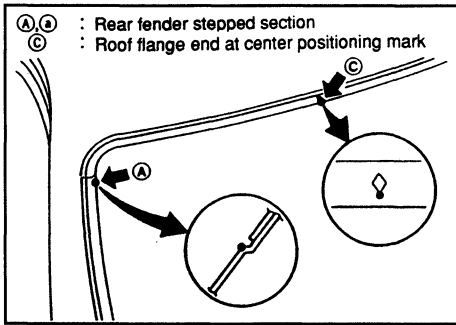

Unit: mm

REAR BODY

MEASUREMENT

2 Door

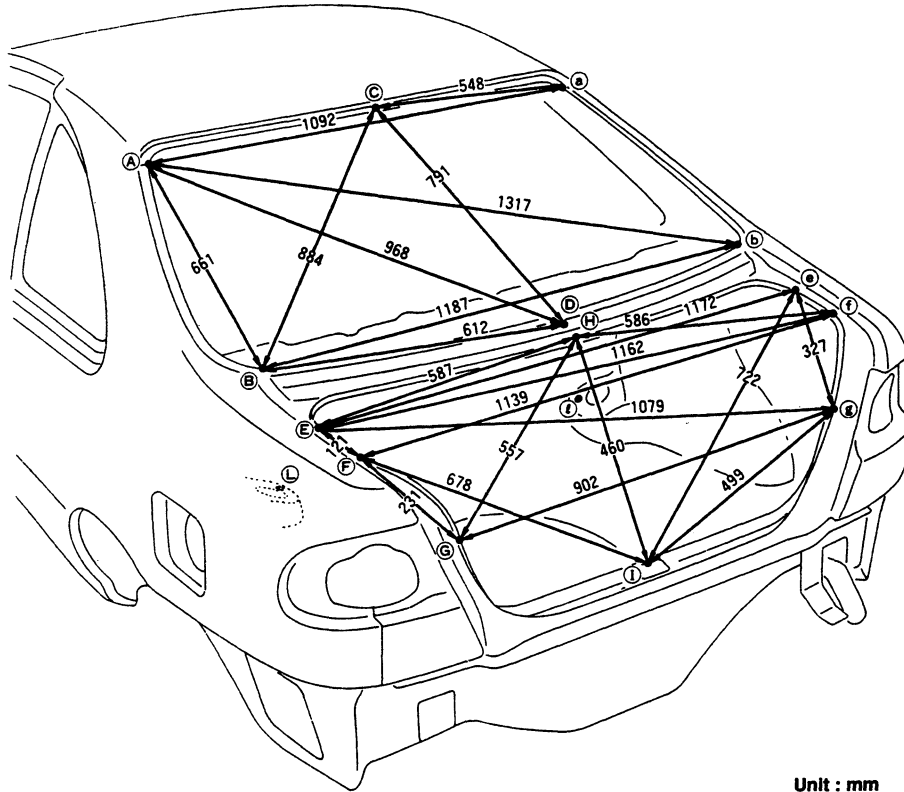

Unit : mm

Note : Figures indicated only on one side show symmetrically identical dimensions on the left and right sides of the vehicle.

Points	Dimensions
①~⑬	937
⑬~①	871

REAR BODY

MEASUREMENT POINTS

2 Door

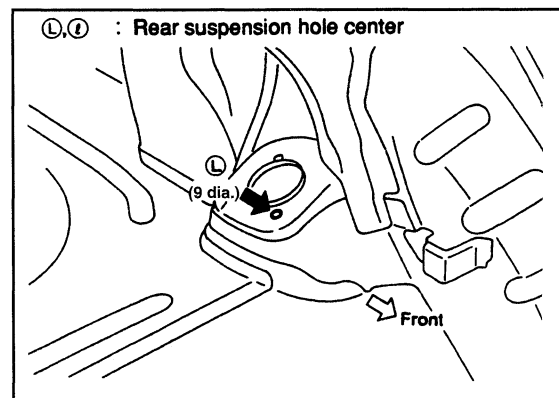
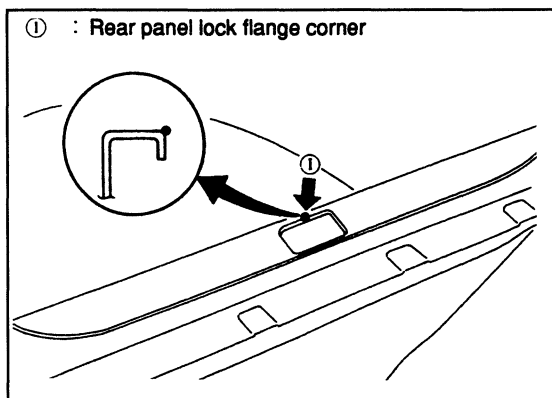
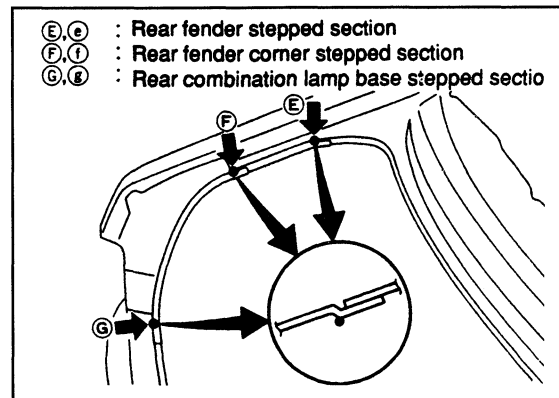
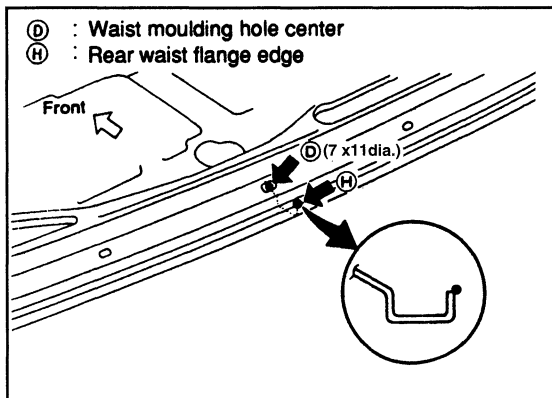
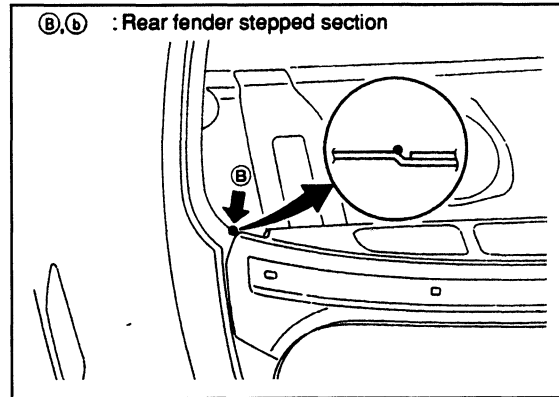
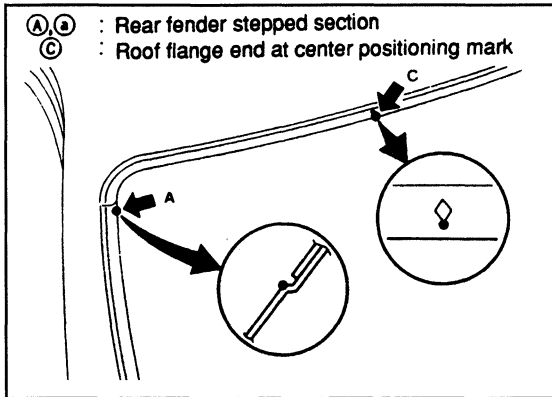

Unit: mm

HANDLING PRECAUTIONS FOR PLASTICS

Abbreviation	Material name	Heat resisting temperature °C (°F)	Resistance to gasoline and solvents	Other cautions
PE	Polyethylene	80 (176)	Gasoline and most solvents are harmless.	Flammable
PET	Polyethylene terephthalate	180 (356)	Gasoline and most solvents are harmless.	
PVC	Polyvinyl chloride	80 (176)	Gasoline and most solvents are harmless if applied for a very short time (wipe up quickly).	Poison gas is emitted when burned.
PP	Polypropylene	90 (194)	Same as above. Also avoid battery acid.	Flammable
ABS	Acrylonitrile butadiene styrene resin	80 (176)	Avoid gasoline and solvents.	
AES	Acrylonitrile ethylene styrene	80 (176)	Avoid gasoline and solvents.	
PMMA	Polymethyl methacrylate	85 (185)	Avoid gasoline and solvents.	
PUR	Polyurethane	90 (194)	Gasoline and most solvents are harmless.	Avoid battery acid.
AAS	Acrylonitrile acrylic rubber styrene	85 (185)	Avoid gasoline and solvents.	
AS	Styrene-acrylonitrile	85 (185)	Avoid gasoline and solvents.	
PPO	Polyphenylene oxide	110 (230)	Avoid gasoline and solvents.	
POM	Polyacetal	120 (248)	Gasoline and solvents are harmless.	Avoid battery acid.
PC	Polycarbonate	120 (248)	Avoid gasoline and solvents.	
PA	Polyamide (Nylon)	140 (284)	Gasoline and most solvents are harmless.	Avoid immersing in water.
FRP	Fiber reinforced plastics	170 (338)	Gasoline and most solvents are harmless.	Avoid battery acid.
PPC	Polypropylene composite	115 (239)	Gasoline and most solvents are harmless.	Flammable
PBT	Polybutylene terephthalate	140 (284)	Gasoline and most solvents are harmless.	
TPR	Thermoplastic rubber	80 (176)	Avoid gasoline and solvents.	
TPE	Thermoplastic elastomer	80 (176)	Avoid gasoline and solvents.	
TPUR	Thermoplastic polyurethane	80 (176)	Avoid gasoline and solvents.	

1. When repairing and painting a portion of the body adjacent to plastic parts, consider their characteristics (influence of heat and solvent) and remove them if necessary or take suitable measures to protect them.
2. Plastic parts should be repaired and painted using methods suitable to the materials.

LOCATION OF PLASTIC PARTS

4 Door

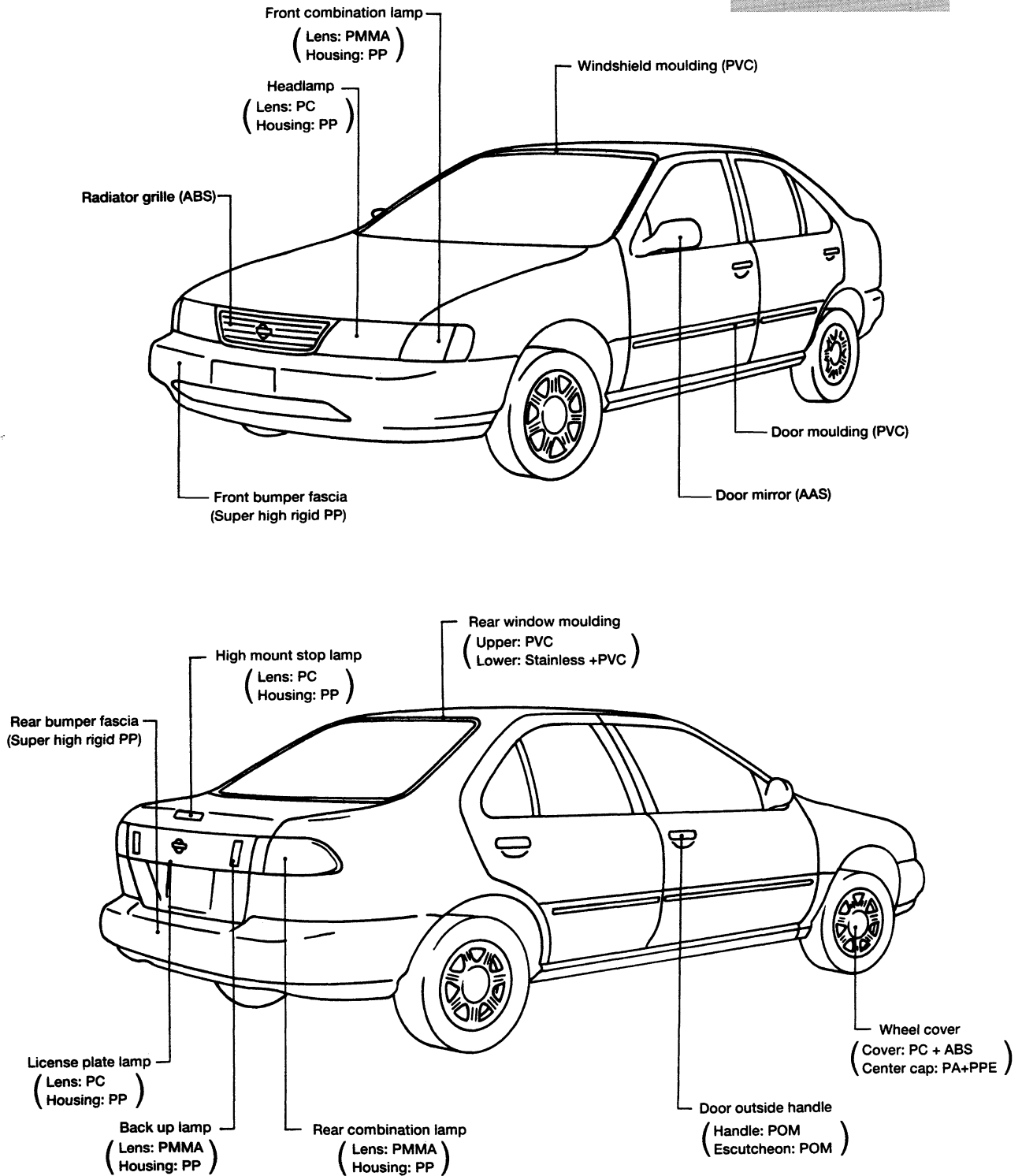

LOCATION OF PLASTIC PARTS

2 Door

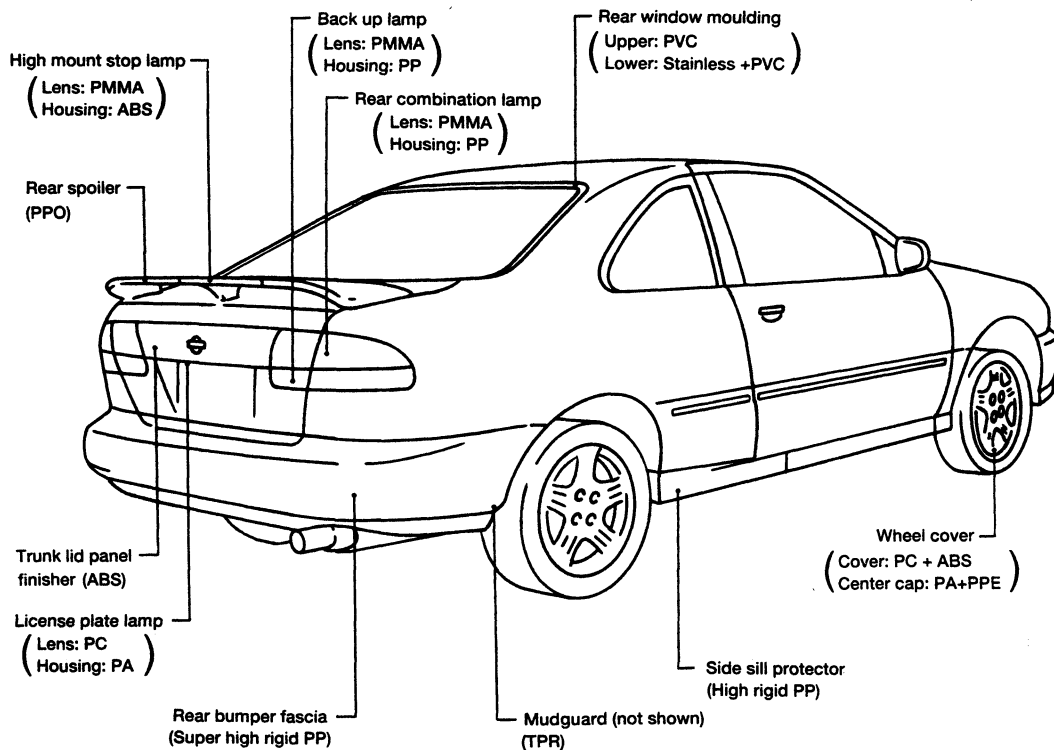
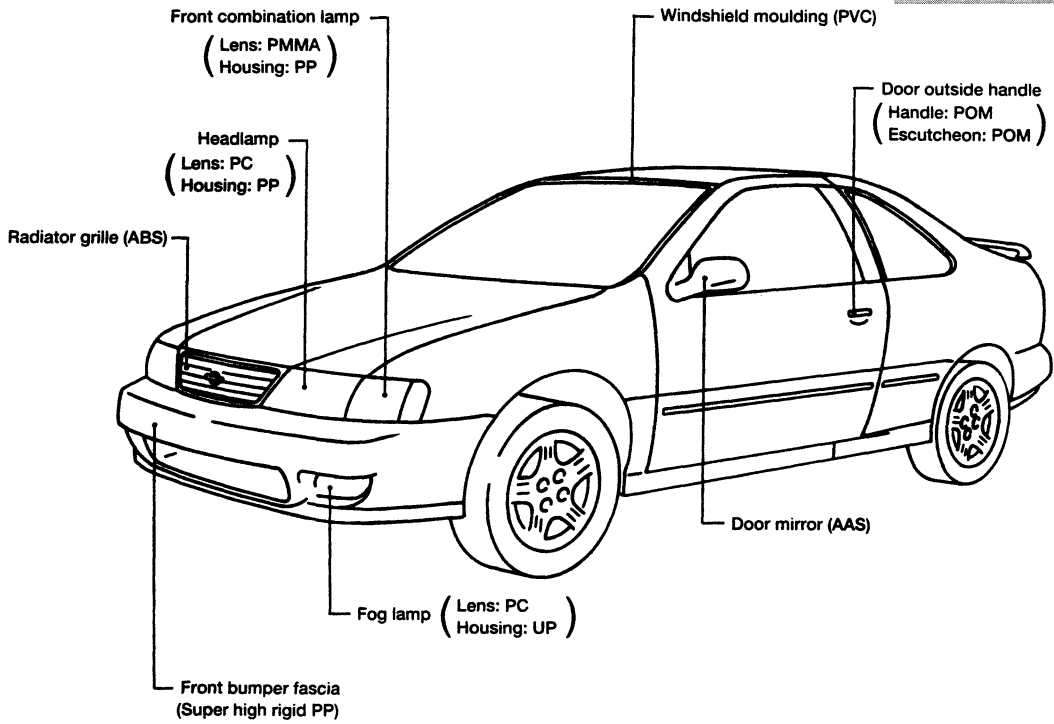

LOCATION OF PLASTIC PARTS

The asterisk * indicates parts with material identification marking.

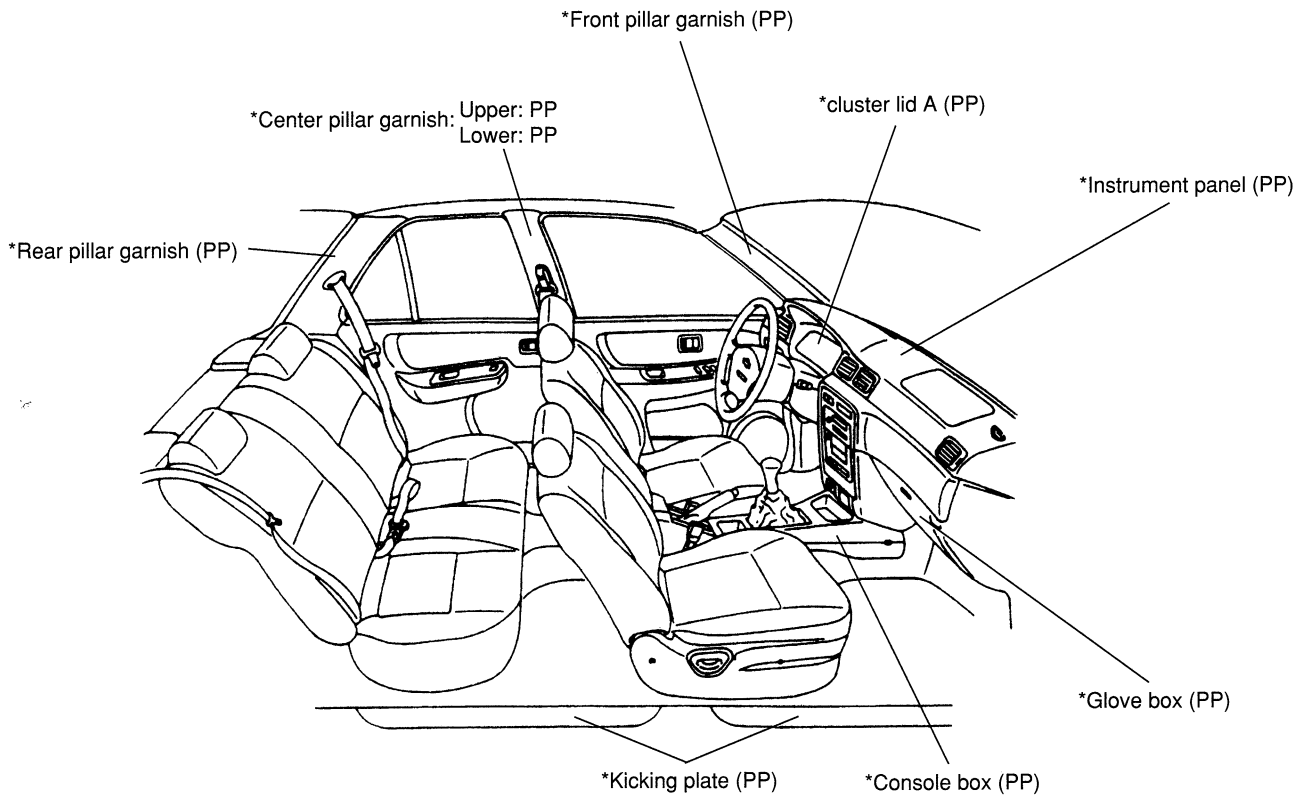

PRECAUTIONS IN REPAIRING HIGH STRENGTH STEEL (HSS)

High strength steel has been used as body panels in order to reduce vehicle weight. Accordingly, precautions in repairing automotive bodies utilizing high strength steel panels are described below:

HIGH STRENGTH STEEL (HSS) USED IN NISSAN VEHICLES

Tensile strength	Nissan designation	Major applicable parts
373 N/mm ² (38 kg/mm ² , 54 klb/sq in)	NP130	<ul style="list-style-type: none">● Side member● Hoodledge● Pillar● Hood● Trunk lid outer
785 – 981 N/mm ² (80 – 100 kg/mm ² , 114 – 142 klb/sq in)	NP150	<ul style="list-style-type: none">● Bumper reinforcement● Door guard bar

In Nissan vehicles, HSS panels of 373 N/mm² (38 kg/mm², 54 klb/sq in) (NP130) are most commonly utilized, panels with a tensile strength of 785 to 981 N/mm² (80 to 100 kg/mm², 114 to 142 klb/sq in) (NP150) are used only on parts requiring significantly more strength.

PRECAUTIONS IN REPAIRING HIGH STRENGTH STEEL (HSS)

Special consideration for HSS must be given to the following points:

1. Additional points to consider

- The repair of reinforcements (such as side members) by heating is not recommended since it involves the risk of lowering strength. When heating is unavoidable, do not heat such parts at temperatures above 550°C (1,022°F). Heating temperature should be verified with a thermometer. (A crayon-type and other thermometer are available.)

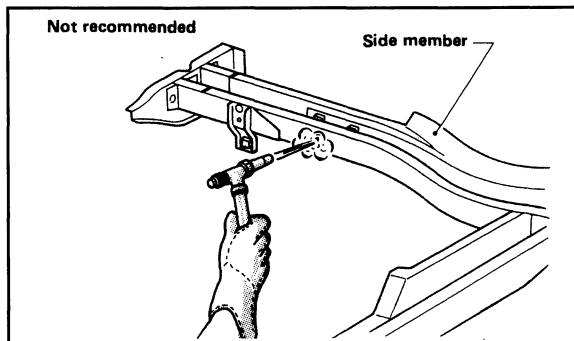

- When straightening body panels, use caution in pulling any HSS panel. Because it is very strong, this may cause deformation in adjacent portions of the body. In this case, increase the number of measuring points, and carefully pull the HSS panel.

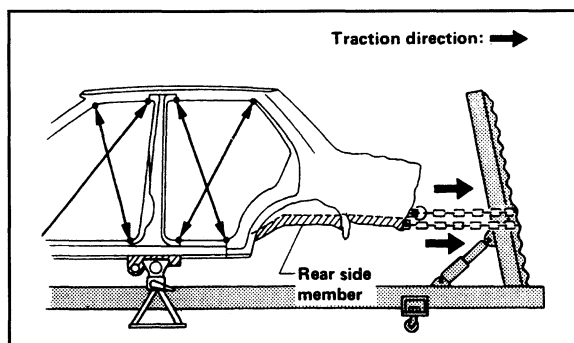

- In cutting HSS panel, avoid gas cutting if possible. Instead, use an air saw or a hand cutter to avoid decreasing the strength of surrounding portions due to the influence of heat. In case gas cutting is inevitable, a minimum allowance of 50 mm (1.97 in) must be given.

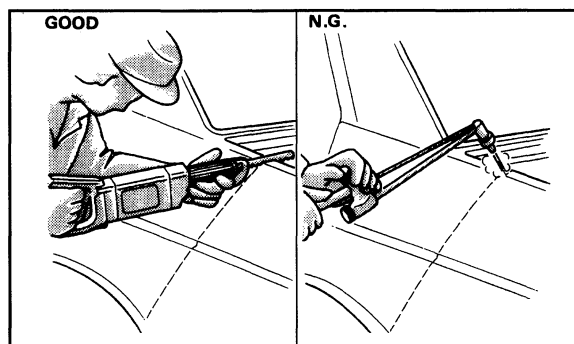

- In welding HSS panel, use spot welding whenever possible in order to minimize any decrease in strength of surrounding portions due to the influence of heat. If spot welding is impossible, use M.I.G. welding. Do not use acetylene gas welding because it is inferior in welding strength.

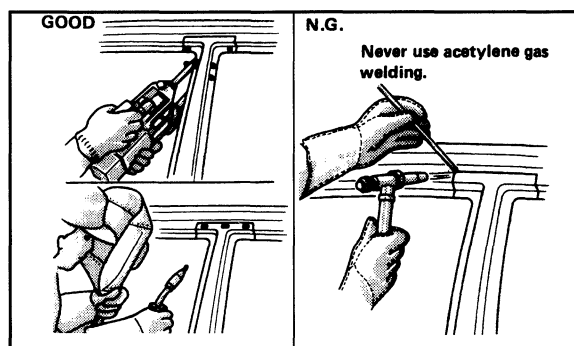

PRECAUTIONS IN REPAIRING HIGH STRENGTH STEEL (HSS)

- The spot nugget on HSS panel is harder than that of an ordinary steel panel. Therefore, for spot cutting HSS panel, a high torque drill of a low speed (1,000 to 1,200 rpm) may be used to maintain its durability and facilitate the operation.

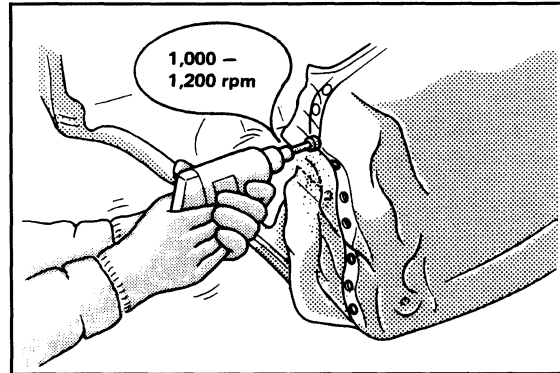

- HSS plate with a tensile strength of 785 to 981 N/mm² (80 to 100 kg/mm², 114 to 142 klb/sq in), used as reinforcement in the door guard bar and in the bumper, is too high in tensile strength to use for general repairs. When these parts are damaged, the outer panels also sustain consequential damage; therefore, these parts are never remedied without replacing the door assembly or bumper assembly.

2. Precautions in spot welding

This work should be performed under standard work conditions. However, work control must be exercised as follows:

- The electrode tip diameter must be reformed properly according to the plate thickness.

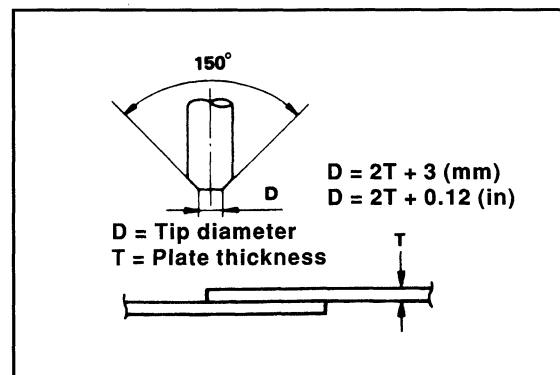

- The panel surfaces must be fitted to each other, leaving no gaps.

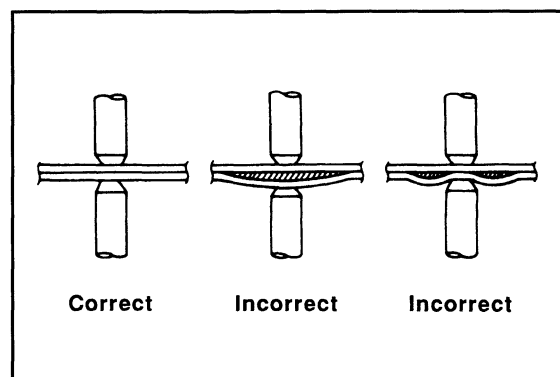

PRECAUTIONS IN REPAIRING HIGH STRENGTH STEEL (HSS)

- Follow established specifications for the appropriate pressure level, current level and weld time.

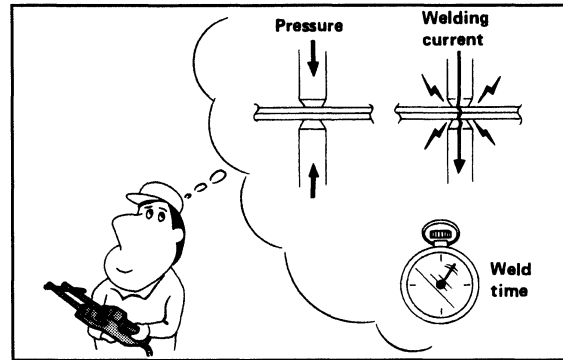

- Follow the specifications for the proper welding pitch.

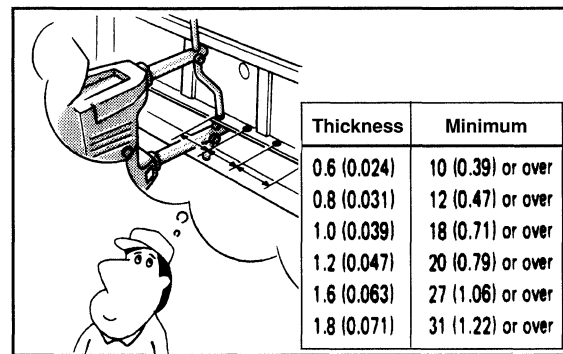

- After welding, welding strength must be tested.

