

SECTION **BL**

**BODY, LOCK & SECURITY SYSTEM**

**CONTENTS**

<b>PRECAUTIONS</b> .....	<b>3</b>	"DOOR LOCK" .....	21
Precautions for Supplemental Restraint System (SRS) "AIR BAG" and "SEAT BELT PRE-TENSIONER" .....	3	Trouble Diagnoses .....	22
<b>PREPARATION</b> .....	<b>4</b>	SYMPTOM CHART .....	22
Special Service Tools .....	4	MAIN POWER SUPPLY AND GROUND CIRCUIT CHECK .....	23
Commercial Service Tools .....	4	DOOR SWITCH CHECK .....	24
<b>SQUEAK AND RATTLE TROUBLE DIAGNOSES</b> .....	<b>5</b>	KEY SWITCH (INSERT) CHECK .....	25
Work Flow .....	5	DOOR LOCK/UNLOCK SWITCH CHECK .....	26
CUSTOMER INTERVIEW .....	5	FRONT DOOR KEY CYLINDER SWITCH CHECK .....	28
DUPLICATE THE NOISE AND TEST DRIVE .....	6	DOOR LOCK ACTUATOR CHECK .....	29
CHECK RELATED SERVICE BULLETINS .....	6	<b>DOOR</b> .....	<b>31</b>
LOCATE THE NOISE AND IDENTIFY THE ROOT CAUSE .....	6	Front Door .....	31
REPAIR THE CAUSE .....	6	Rear Door .....	31
CONFIRM THE REPAIR .....	7	<b>TRUNK LID OPENER</b> .....	<b>33</b>
Generic Squeak and Rattle Troubleshooting .....	7	Wiring Diagram — TLID — .....	33
INSTRUMENT PANEL .....	7	<b>REMOTE KEYLESS ENTRY SYSTEM</b> .....	<b>34</b>
CENTER CONSOLE .....	7	Component Parts and Harness Connector Location..	34
DOORS .....	7	System Description .....	35
TRUNK .....	9	INPUTS .....	35
SUNROOF/HEADLINER .....	9	OPERATED PROCEDURE .....	35
SEATS .....	9	Schematic .....	38
UNDERHOOD .....	9	Wiring Diagram — KEYLES — .....	39
Diagnostic Worksheet .....	10	FIG. 1 .....	39
<b>POWER DOOR LOCK</b> .....	<b>12</b>	FIG. 2 .....	40
Component Parts and Harness Connector Location..	12	FIG. 3 .....	41
System Description .....	13	CONSULT-II Inspection Procedure .....	42
OPERATION .....	13	"MULTI REMOTE ENT" .....	42
Schematic .....	14	CONSULT-II Application Items .....	43
Wiring Diagram — D/LOCK — .....	15	"MULTI REMOTE ENT" .....	43
FIG. 1 .....	15	Trouble Diagnoses .....	44
FIG. 2 .....	16	SYMPTOM CHART .....	44
FIG. 3 .....	17	KEYFOB BATTERY AND FUNCTION CHECK ...	46
FIG. 4 .....	18	POWER SUPPLY AND GROUND CIRCUIT CHECK .....	47
FIG. 5 .....	19	DOOR SWITCH CHECK .....	49
CONSULT-II Inspection Procedure .....	20	KEY SWITCH (INSERT) CHECK .....	50
"DOOR LOCK" .....	20	DOOR LOCK/UNLOCK SWITCH LH CHECK ....	51
CONSULT-II Application Items .....	21	FRONT LH DOOR UNLOCK SENSOR CHECK..	53
		TRUNK LID OPENER ACTUATOR CHECK .....	55

HAZARD REMINDER CHECK .....	56	DOOR KEY CYLINDER SWITCH CHECK .....	88
HORN REMINDER CHECK .....	58	TRUNK LID KEY CYLINDER SWITCH CHECK...	89
INTERIOR LAMP OPERATION CHECK .....	59	DOOR LOCK/UNLOCK SWITCH CHECK .....	90
ID Code Entry Procedure .....	60	HORN AND HEADLAMP ALARM CHECK .....	92
KEYFOB ID SET UP WITH CONSULT-II .....	60	Electrical Components Inspection .....	94
KEYFOB ID SET UP WITHOUT CONSULT-II ....	62	VEHICLE SECURITY LAMP RELAY .....	94
Keyfob Battery Replacement .....	63	<b>NVIS (NISSAN VEHICLE IMMOBILIZER SYSTEM</b>	
<b>VEHICLE SECURITY (THEFT WARNING) SYSTEM..</b>	<b>64</b>	<b>— NATS) .....</b>	<b>95</b>
Component Parts and Harness Connector Location..	64	Component Parts and Harness Connector Location..	95
System Description .....	66	System Description .....	96
DESCRIPTION .....	66	System Composition .....	96
POWER SUPPLY AND GROUND .....	66	Wiring Diagram — NATS — .....	97
INITIAL CONDITION TO ACTIVATE THE SYS-		CONSULT-II .....	98
TEM .....	67	CONSULT-II INSPECTION PROCEDURE .....	98
VEHICLE SECURITY SYSTEM ACTIVATION ...	67	CONSULT-II DIAGNOSTIC TEST MODE FUNC-	
VEHICLE SECURITY SYSTEM ALARM OPER-		TION .....	99
ATION .....	68	HOW TO READ SELF-DIAGNOSTIC RESULTS..	99
VEHICLE SECURITY SYSTEM DEACTIVATION..	68	NVIS (NATS) SELF-DIAGNOSTIC RESULTS	
PANIC ALARM OPERATION .....	69	ITEM CHART .....	100
Schematic .....	70	Trouble Diagnoses .....	101
Wiring Diagram — VEHSEC — .....	71	WORK FLOW .....	101
FIG. 1 .....	71	SYMPTOM MATRIX CHART 1 (SELF-DIAGNO-	
FIG. 2 .....	72	SIS RELATED ITEM) .....	102
FIG. 3 .....	73	SYMPTOM MATRIX CHART 2 (NON SELF-	
FIG. 4 .....	74	DIAGNOSIS RELATED ITEM) .....	102
CONSULT-II Inspection Procedure .....	75	DIAGNOSTIC SYSTEM DIAGRAM .....	103
“THEFT WAR ALM” .....	75	DIAGNOSTIC PROCEDURE 1 .....	103
CONSULT-II Application Item .....	76	DIAGNOSTIC PROCEDURE 2 .....	104
“THEFT WAR ALM” .....	76	DIAGNOSTIC PROCEDURE 3 .....	108
Trouble Diagnoses .....	77	DIAGNOSTIC PROCEDURE 4 .....	109
PRELIMINARY CHECK .....	77	DIAGNOSTIC PROCEDURE 5 .....	110
SYMPTOM CHART .....	78	DIAGNOSTIC PROCEDURE 6 .....	111
POWER SUPPLY AND GROUND CIRCUIT		DIAGNOSTIC PROCEDURE 7 .....	113
CHECK .....	79	How to Replace NVIS (NATS) IMMU .....	114
DOOR, HOOD AND TRUNK ROOM LAMP		<b>BODY (ALIGNMENT) .....</b>	<b>115</b>
SWITCH CHECK .....	80	Alignment .....	115
SECURITY INDICATOR LAMP CHECK .....	85	ENGINE COMPARTMENT .....	116
FRONT DOOR UNLOCK SENSOR CHECK .....	87	UNDERBODY .....	119

# PRECAUTIONS

## PRECAUTIONS

PF0:00001

### Precautions for Supplemental Restraint System (SRS) “AIR BAG” and “SEAT BELT PRE-TENSIONER”

EIS00140

The Supplemental Restraint System such as “AIR BAG” and “SEAT BELT PRE-TENSIONER”, used along with a front seat belt, helps to reduce the risk or severity of injury to the driver and front passenger for certain types of collision. Information necessary to service the system safely is included in the SRS and SB section of this Service Manual.

#### **WARNING:**

- To avoid rendering the SRS inoperative, which could increase the risk of personal injury or death in the event of a collision which would result in air bag inflation, all maintenance must be performed by an authorized NISSAN/INFINITI dealer.
- Improper maintenance, including incorrect removal and installation of the SRS, can lead to personal injury caused by unintentional activation of the system. For removal of Spiral Cable and Air Bag Module, see the SRS section.
- Do not use electrical test equipment on any circuit related to the SRS unless instructed to in this Service Manual. SRS wiring harnesses can be identified by yellow and/or orange harnesses or harness connectors.

A

B

C

D

E

F

G

H

BL

J

K

L

M

# PREPARATION

## PREPARATION

PFP:00002

### Special Service Tools

EIS0014P

The actual shapes of Kent-Moore tools may differ from those of special service tools illustrated here.

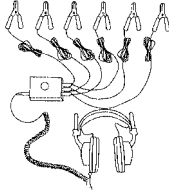
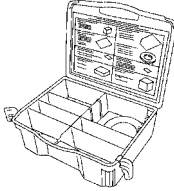
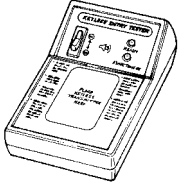
Tool number (Kent-Moore No.) Tool name		Description
— (J-39570) Chassis ear	 <p style="text-align: center; font-size: small;">SIIA0993E</p>	Locating the noise
— (J-43980) Nissan Squeak and Rattle kit	 <p style="text-align: center; font-size: small;">SIIA0994E</p>	Repairing the cause of noise
— (J-43241) Remote Keyless Entry Tester	 <p style="text-align: center; font-size: small;">LEL946A</p>	Used to test keyfobs

### Commercial Service Tools

EIS0014Q

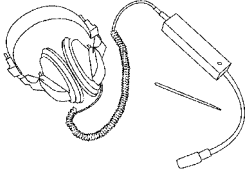
Tool name		Description
Engine ear (J-39565)	 <p style="text-align: center; font-size: small;">SIIA0995E</p>	Locating the noise

# SQUEAK AND RATTLE TROUBLE DIAGNOSES

## SQUEAK AND RATTLE TROUBLE DIAGNOSES

PFP:00003

### Work Flow

EIS0014R

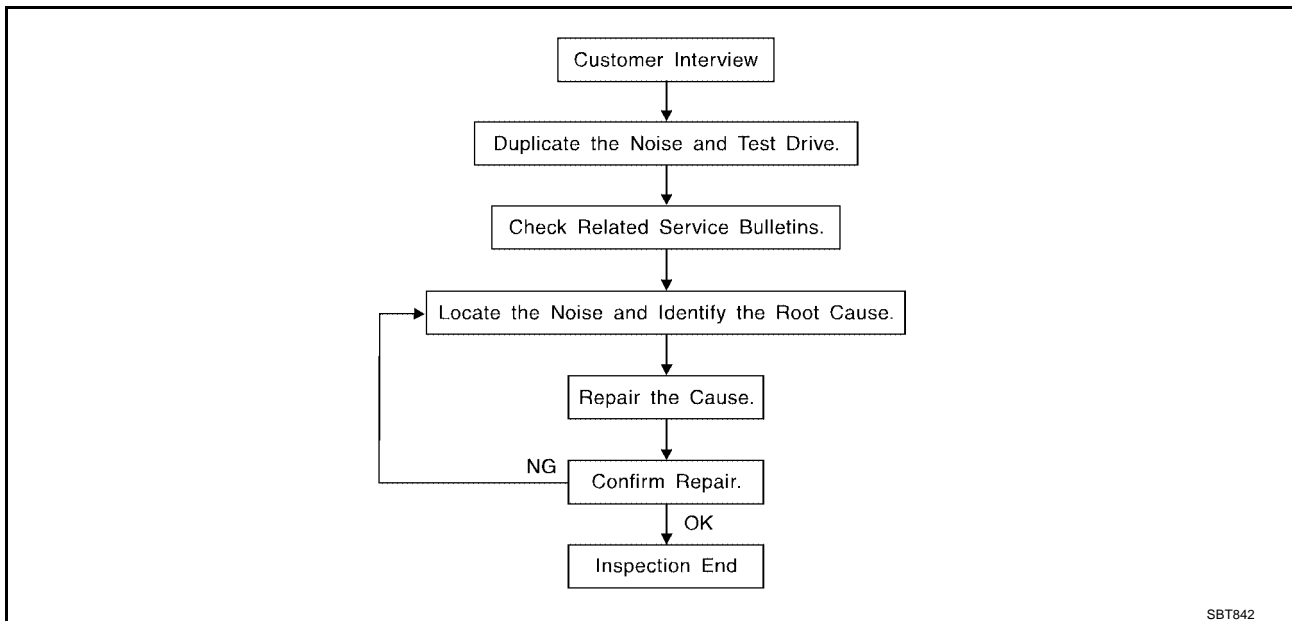

### CUSTOMER INTERVIEW

Interview the customer, if possible, to determine the conditions that exist when the noise occurs. Use the Diagnostic Worksheet during the interview to document the facts and conditions when the noise occurs and any customer's comments; refer to [BL-10, "Diagnostic Worksheet"](#). This information is necessary to duplicate the conditions that exist when the noise occurs.

- The customer may not be able to provide a detailed description or the location of the noise. Attempt to obtain all the facts and conditions that exist when the noise occurs (or does not occur).
- If there is more than one noise in the vehicle, be sure to diagnose and repair the noise that the customer is concerned about. This can be accomplished by test driving the vehicle with the customer.
- After identifying the type of noise, isolate the noise in terms of its characteristics. The noise characteristics are provided so the customer, service adviser and technician are all speaking the same language when defining the noise.
- Squeak — (Like tennis shoes on a clean floor)  
Squeak characteristics include the light contact/fast movement/brought on by road conditions/hard surfaces = higher pitch noise/softer surfaces = lower pitch noises/edge to surface = chirping
- Creak — (Like walking on an old wooden floor)  
Creak characteristics include firm contact/slow movement/twisting with a rotational movement/pitch dependent on materials/often brought on by activity.
- Rattle — (Like shaking a baby rattle)  
Rattle characteristics include the fast repeated contact/vibration or similar movement/loose parts/missing clip or fastener/incorrect clearance.
- Knock — (Like a knock on a door)  
Knock characteristics include hollow sounding/sometimes repeating/often brought on by driver action.
- Tick — (Like a clock second hand)  
Tick characteristics include gentle contacting of light materials/loose components/can be caused by driver action or road conditions.
- Thump — (Heavy, muffled knock noise)  
Thump characteristics include softer knock/dead sound often brought on by activity.
- Buzz — (Like a bumblebee)  
Buzz characteristics include high frequency rattle/firm contact.
- Often the degree of acceptable noise level will vary depending upon the person. A noise that you may judge as acceptable may be very irritating to the customer.
- Weather conditions, especially humidity and temperature, may have a great effect on noise level.

# SQUEAK AND RATTLE TROUBLE DIAGNOSES

---

## DUPLICATE THE NOISE AND TEST DRIVE

If possible, drive the vehicle with the customer until the noise is duplicated. Note any additional information on the Diagnostic Worksheet regarding the conditions or location of the noise. This information can be used to duplicate the same conditions when you confirm the repair.

If the noise can be duplicated easily during the test drive, to help identify the source of the noise, try to duplicate the noise with the vehicle stopped by doing one or all of the following:

1. Close a door.
  2. Tap or push/pull around the area where the noise appears to be coming from.
  3. Rev the engine.
  4. Use a floor jack to recreate vehicle "twist".
  5. At idle, apply engine load (electrical load, half-clutch on M/T model, drive position on A/T model).
  6. Raise the vehicle on a hoist and hit a tire with a rubber hammer.
- Drive the vehicle and attempt to duplicate the conditions the customer states exist when the noise occurs.
  - If it is difficult to duplicate the noise, drive the vehicle slowly on an undulating or rough road to stress the vehicle body.

## CHECK RELATED SERVICE BULLETINS

After verifying the customer concern or symptom, check ASIST for Technical Service Bulletins (TSBs) related to that concern or symptom.

If a TSB relates to the symptom, follow the procedure to repair the noise.

## LOCATE THE NOISE AND IDENTIFY THE ROOT CAUSE

1. Narrow down the noise to a general area. To help pinpoint the source of the noise, use a listening tool (Chassis Ear: J-39570, Engine Ear: J-39565 and mechanics stethoscope).
2. Narrow down the noise to a more specific area and identify the cause of the noise by:
  - Removing the components in the area that you suspect the noise is coming from.  
**Do not use too much force when removing clips and fasteners, otherwise clips and fasteners can be broken or lost during the repair, resulting in the creation of new noise.**
  - Tapping or pushing/pulling the component that you suspect is causing the noise.  
**Do not tap or push/pull the component with excessive force, otherwise the noise will be eliminated only temporarily.**
  - Feeling for a vibration with your hand by touching the component(s) that you suspect is (are) causing the noise.
  - Placing a piece of paper between components that you suspect are causing the noise.
  - Looking for loose components and contact marks.

Refer to [BL-7, "Generic Squeak and Rattle Troubleshooting"](#) .

## REPAIR THE CAUSE

- If the cause is a loose component, tighten the component securely.
- If the cause is insufficient clearance between components:
  - Separate components by repositioning or loosening and retightening the component, if possible.
  - Insulate components with a suitable insulator such as urethane pads, foam blocks, felt cloth tape or urethane tape. A Nissan Squeak and Rattle Kit (J-43980) is available through your authorized Nissan Parts Department.

### CAUTION:

**Do not use excessive force as many components are constructed of plastic and may be damaged. Always check with the Parts Department for the latest parts information.**

The following materials are contained in the Nissan Squeak and Rattle Kit (J-43980). Each item can be ordered separately as needed.

URETHANE PADS [1.5 mm (0.059 in) thick]

Insulates connectors, harness, etc.

76268-9E005: 100 x 135 mm (3.94 x 5.31 in)/76884-71L01: 60 x 85 mm (2.36 x 3.35 in)/76884-71L02: 15 x 25 mm (0.59 x 0.98 in)

INSULATOR (Foam blocks)

Insulates components from contact. Can be used to fill space behind a panel.

# SQUEAK AND RATTLE TROUBLE DIAGNOSES

73982-9E000: 45 mm (1.77 in) thick, 50 x 50 mm (1.97 x 1.97 in)/73982-50Y00: 10 mm (0.39 in) thick, 50 x 50 mm (1.97 x 1.97 in)

INSULATOR (Light foam block)

80845-71L00: 30 mm (1.18 in) thick, 30 x 50 mm (1.18 x 1.97 in)

FELT CLOTH TAPE

Used to insulate where movement does not occur. Ideal for instrument panel applications.

68370-4B000: 15 x 25 mm (0.59 x 0.98 in) pad/68239-13E00: 5 mm (0.20 in) wide tape roll

The following materials, not found in the kit, can also be used to repair squeaks and rattles.

UHMW (TEFLON) TAPE

Insulates where slight movement is present. Ideal for instrument panel applications.

SILICONE GREASE

Used in place of UHMW tape that will be visible or not fit.

Note: Will only last a few months.

SILICONE SPRAY

Use when grease cannot be applied.

DUCT TAPE

Use to eliminate movement.

## CONFIRM THE REPAIR

Confirm that the cause of a noise is repaired by test driving the vehicle. Operate the vehicle under the same conditions as when the noise originally occurred. Refer to the notes on the Diagnostic Worksheet.

## Generic Squeak and Rattle Troubleshooting

EIS0014S

Refer to Table of Contents for specific component removal and installation information.

## INSTRUMENT PANEL

Most incidents are caused by contact and movement between:

1. The cluster lid A and instrument panel
2. Acrylic lens and combination meter housing
3. Instrument panel to front pillar garnish
4. Instrument panel to windshield
5. Instrument panel mounting pins
6. Wiring harnesses behind the combination meter
7. A/C defroster duct and duct joint

These incidents can usually be located by tapping or moving the components to duplicate the noise or by pressing on the components while driving to stop the noise. Most of these incidents can be repaired by applying felt cloth tape or silicone spray (in hard to reach areas). Urethane pads can be used to insulate wiring harness.

### CAUTION:

**Do not use silicone spray to isolate a squeak or rattle. If you saturate the area with silicone, you will not be able to recheck the repair.**

## CENTER CONSOLE

Components to pay attention to include:

1. Shifter assembly cover to finisher
2. A/C control unit and upper/lower cluster lid C
3. Wiring harnesses behind audio and A/C control unit

The instrument panel repair and isolation procedures also apply to the center console.

## DOORS

Pay attention to the:

1. Finisher and inner panel making a slapping noise
2. Inside handle escutcheon to door finisher
3. Wiring harnesses tapping
4. Door striker out of alignment causing a popping noise on starts and stops

## **SQUEAK AND RATTLE TROUBLE DIAGNOSES**

---

Tapping or moving the components or pressing on them while driving to duplicate the conditions can isolate many of these incidents. You can usually insulate the areas with felt cloth tape or insulator foam blocks from the Nissan Squeak and Rattle Kit (J-43980) to repair the noise.



# SQUEAK AND RATTLE TROUBLE DIAGNOSES

## TRUNK

Trunk noises are often caused by a loose jack or loose items put into the trunk by the owner. In addition look for:

1. Trunk lid bumpers out of adjustment
2. Trunk lid striker out of adjustment
3. The trunk lid torsion bars knocking together
4. A loose license plate or bracket

Most of these incidents can be repaired by adjusting, securing or insulating the item(s) or component(s) causing the noise.

## SUNROOF/HEADLINER

Noises in the sunroof/headliner area can often be traced to one of the following:

1. Sunroof lid, rail, linkage or seals making a rattle or light knocking noise
2. Sun visor shaft shaking in the holder
3. Front or rear windshield touching headliner and squeaking

Again, pressing on the components to stop the noise while duplicating the conditions can isolate most of these incidents. Repairs usually consist of insulating with felt cloth tape.

## SEATS

When isolating seat noises it is important to note the position the seat is in and the load placed on the seat when the noise is present. These conditions should be duplicated when verifying and isolating the cause of the noise.

Cause of seat noise include:

1. Headrest rods and holders
2. A squeak between the seat pad cushion and frame
3. The rear seat back lock and bracket

These noises can be isolated by moving or pressing on the suspected components while duplicating the conditions under which the noise occurs. Most of these incidents can be repaired by repositioning the component or applying urethane tape to the contact area.

## UNDERHOOD

Some interior noises may be caused by components under the hood or on the engine wall. The noise is then transmitted into the passenger compartment.

Causes of transmitted underhood noises include:

1. Any component mounted to the engine wall
2. Components that pass through the engine wall
3. Engine wall mounts and connectors
4. Loose radiator mounting pins
5. Hood bumpers out of adjustment
6. Hood striker out of adjustment

These noises can be difficult to isolate since they cannot be reached from the interior of the vehicle. The best method is to secure, move or insulate one component at a time and test drive the vehicle. Also, engine RPM or load can be changed to isolate the noise. Repairs can usually be made by moving, adjusting, securing, or insulating the component causing the noise.

A

B

C

D

E

F

G

H

BL

J

K

L

M

# SQUEAK AND RATTLE TROUBLE DIAGNOSES

## Diagnostic Worksheet

EIS0014T



### SQUEAK & RATTLE DIAGNOSTIC WORKSHEET

Dear Nissan Customer:

We are concerned about your satisfaction with your Nissan vehicle. Repairing a squeak or rattle sometimes can be very difficult. To help us fix your Nissan right the first time, please take a moment to note the area of the vehicle where the squeak or rattle occurs and under what conditions. You may be asked to take a test drive with a service advisor or technician to ensure we confirm the noise you are hearing.

#### I. WHERE DOES THE NOISE COME FROM? (circle the area of the vehicle)

The illustrations are for reference only, and may not reflect the actual configuration of your vehicle.

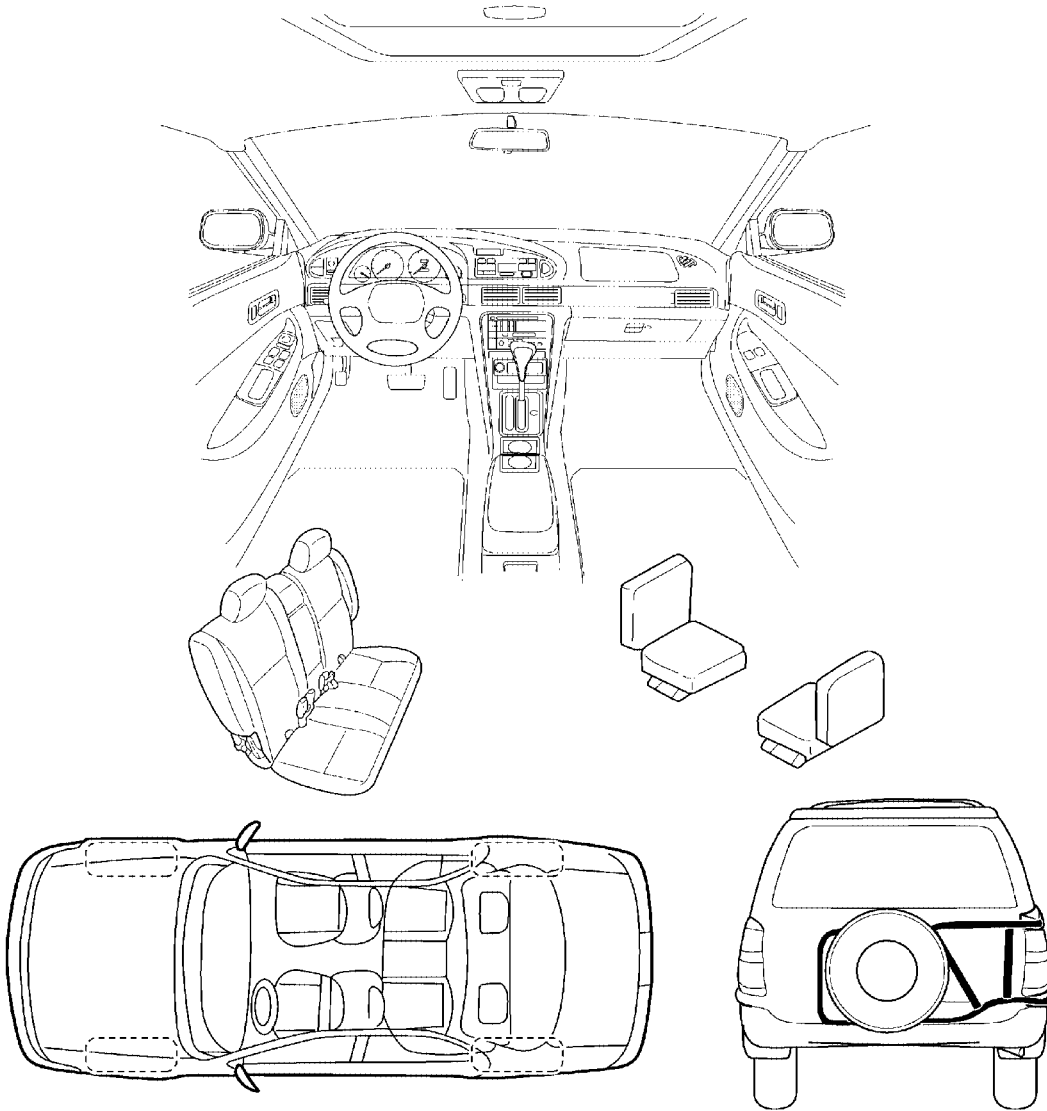

Continue to the back of the worksheet and briefly describe the location of the noise or rattle. In addition, please indicate the conditions which are present when the noise occurs.

SBT843

# SQUEAK AND RATTLE TROUBLE DIAGNOSES

## SQUEAK & RATTLE DIAGNOSTIC WORKSHEET- page 2

**Briefly describe the location where the noise occurs:**

---



---



---

**II. WHEN DOES IT OCCUR? (check the boxes that apply)**

- |  |   |
|--|---|
| <input type="checkbox"/> anytime                             | <input type="checkbox"/> after sitting out in the sun |
| <input type="checkbox"/> 1 <sup>st</sup> time in the morning | <input type="checkbox"/> when it is raining or wet    |
| <input type="checkbox"/> only when it is cold outside        | <input type="checkbox"/> dry or dusty conditions      |
| <input type="checkbox"/> only when it is hot outside         | <input type="checkbox"/> other: _____                 |

**III. WHEN DRIVING:**

- through driveways
- over rough roads
- over speed bumps
- only at about \_\_\_\_ mph
- on acceleration
- coming to a stop
- on turns : left, right or either (circle)
- with passengers or cargo
- other: \_\_\_\_\_
- after driving \_\_\_\_ miles or \_\_\_\_ minutes

**IV. WHAT TYPE OF NOISE?**

- squeak (like tennis shoes on a clean floor)
- creak (like walking on an old wooden floor)
- rattle (like shaking a baby rattle)
- knock (like a knock on a door)
- tick (like a clock second hand)
- thump (heavy, muffled knock noise)
- buzz (like a bumble bee)

**TO BE COMPLETED BY DEALERSHIP PERSONNEL**

**Test Drive Notes:**

---



---

	<u>YES</u>	<u>NO</u>	<u>Initials of person performing</u>
Vehicle test driven with customer	<input type="checkbox"/>	<input type="checkbox"/>	_____
- Noise verified on test drive	<input type="checkbox"/>	<input type="checkbox"/>	_____
- Noise source located and repaired	<input type="checkbox"/>	<input type="checkbox"/>	_____
- Follow up test drive performed to confirm repair	<input type="checkbox"/>	<input type="checkbox"/>	_____

VIN: \_\_\_\_\_ Customer Name: \_\_\_\_\_

W.O. #: \_\_\_\_\_ Date: \_\_\_\_\_

**This form must be attached to Work Order**

SBT844

A  
B  
C  
D  
E  
F  
G  
H  
BL  
J  
K  
L  
M

# POWER DOOR LOCK

## POWER DOOR LOCK

PF2:24814

### Component Parts and Harness Connector Location

EIS0014U

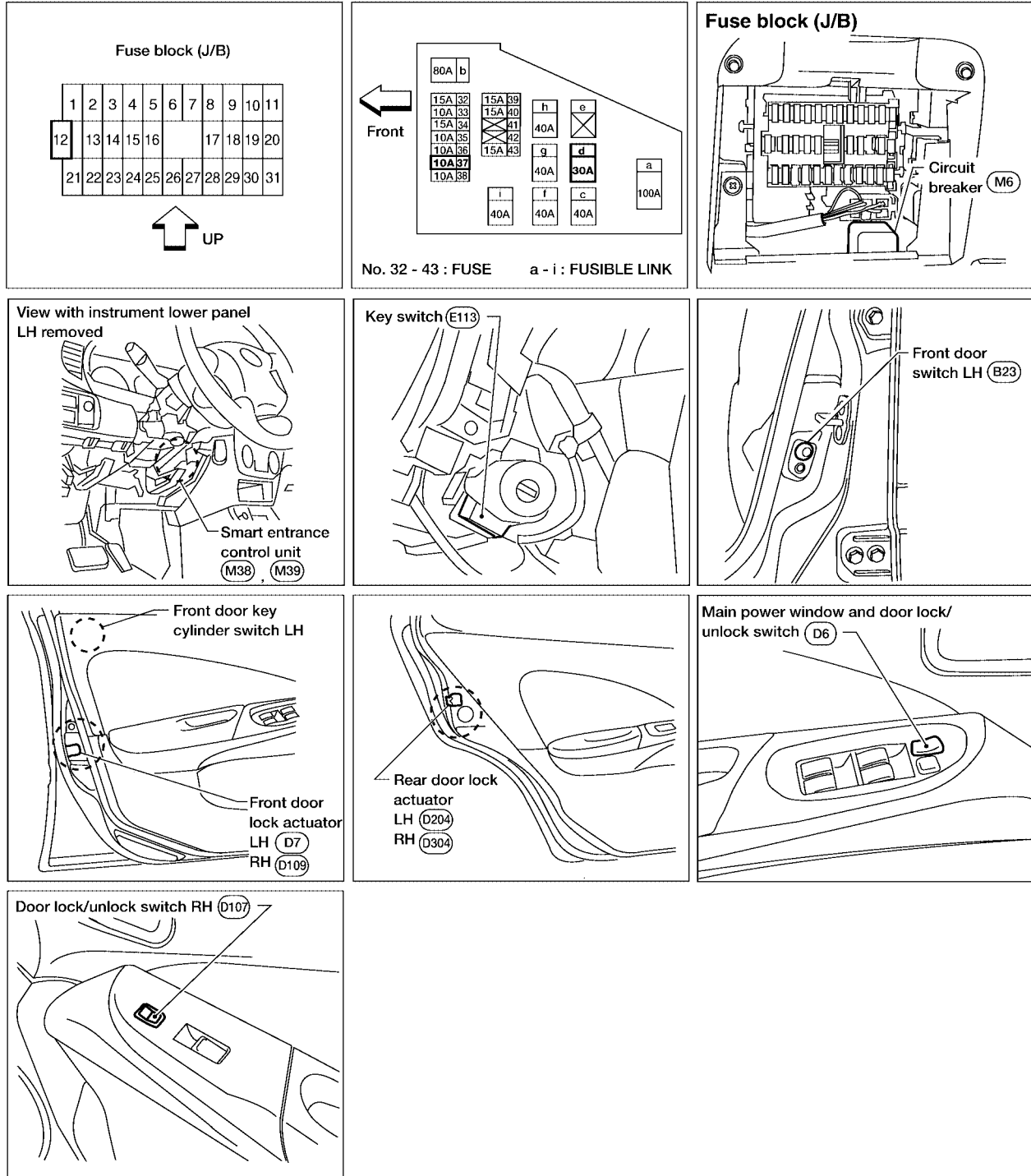

W11A0005E

# POWER DOOR LOCK

## System Description OPERATION

EIS0014V

- The lock/unlock switches (LH and RH) on door trim can lock and unlock all doors.
- With the door key inserted in the key cylinder on front LH, turning it to "LOCK", will lock all doors; turning it to "UNLOCK" once unlocks the corresponding door; turning it to "UNLOCK" again within 5 seconds after the first unlock operation unlocks all of the other doors. (Signals from door key cylinder switch.)
- If the ignition key is in the ignition key cylinder and one or more of the doors are open, setting the lock/unlock switch (LH or RH) to "LOCK" locks the doors once but then immediately unlocks them (KEY REMINDER DOOR SYSTEM).

A

B

C

D

E

F

G

H

BL

J

K

L

M

# POWER DOOR LOCK

## Schematic

EIS0014W

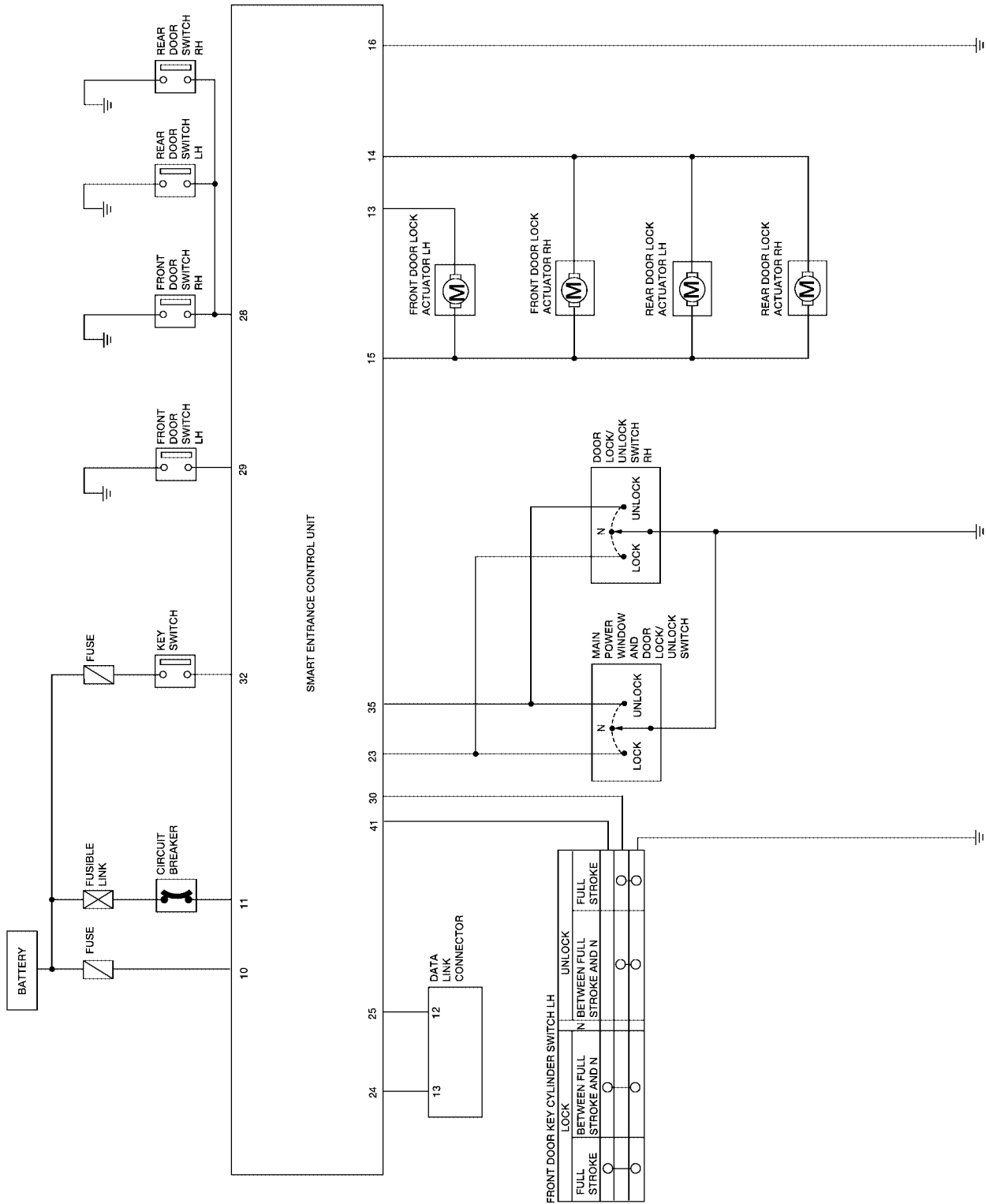

WIWA0014E

# POWER DOOR LOCK

EIS0014X

**Wiring Diagram — D/LOCK —**  
**FIG. 1**

BL-D/LOCK-01

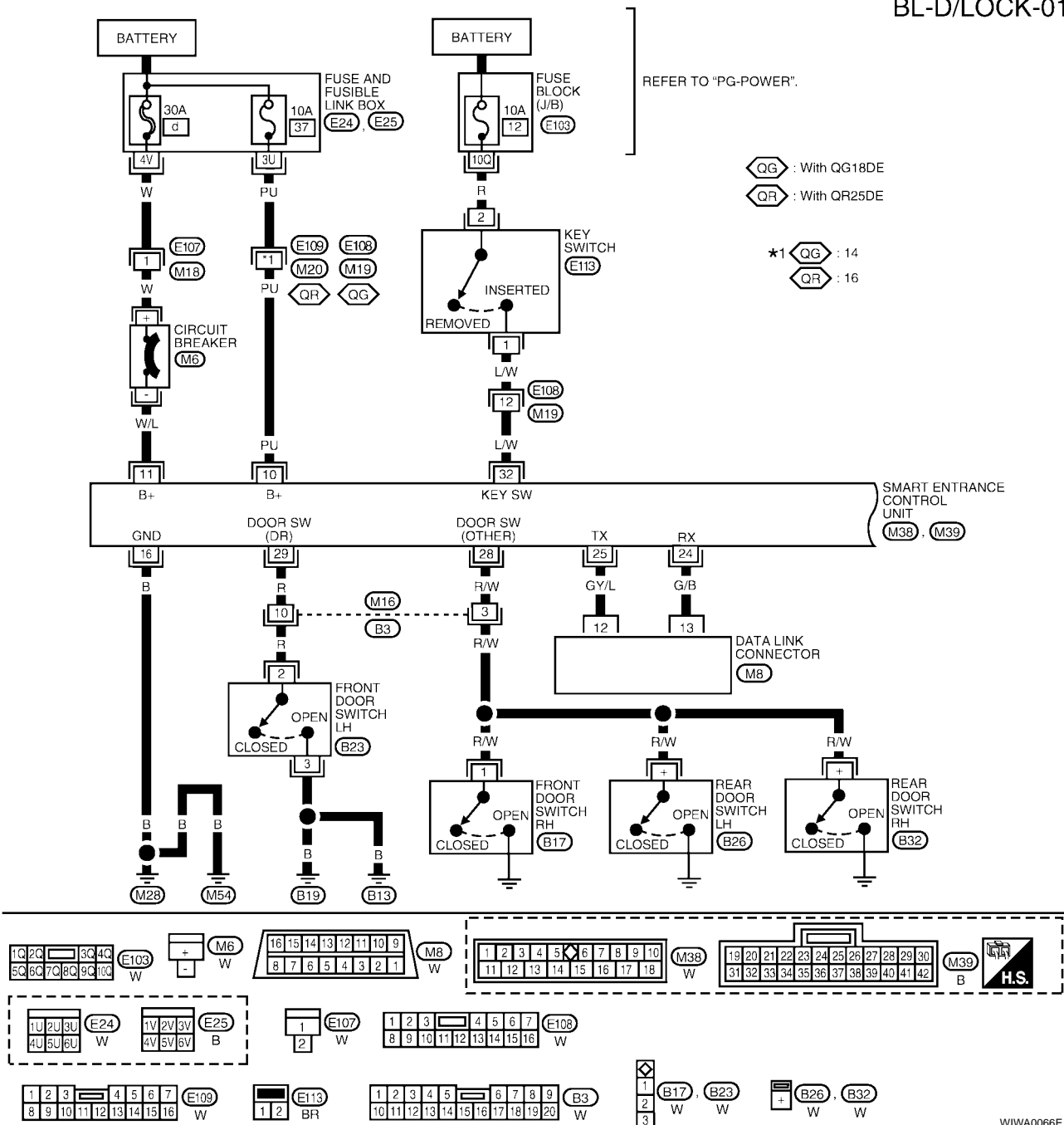

SMART ENTRANCE CONTROL UNIT TERMINALS AND REFERENCE VALUE MEASURED BETWEEN EACH TERMINAL AND GROUND

TERMINAL	WIRE COLOR	ITEM	CONDITION	DATA (DC)
10	PU	POWER SOURCE (FUSE)	—	12V
11	W/L	POWER SOURCE (CIRCUIT BREAKER)	—	12V
16	B	GROUND	—	—
28	R/W	OTHER DOOR SWITCHES	OFF (CLOSED)	5V
			ON (OPEN)	0V
29	R	FRONT DOOR SWITCH LH	OFF (CLOSED)	5V
			ON (OPEN)	0V
32	L/W	IGNITION KEY SWITCH (INSERT)	IGNITION KEY IS INSERTED	12V
			IGNITION KEY IS REMOVED	0V
33	G	IGNITION SWITCH (ON)	IGNITION KEY IS IN ON POSITION	12V
			IGNITION SWITCH (START)	12V

LEL606

# POWER DOOR LOCK

FIG. 2

BL-D/LOCK-02

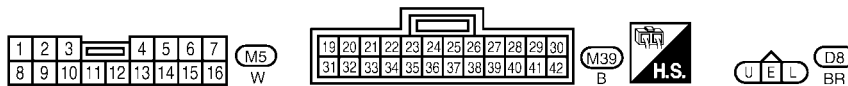
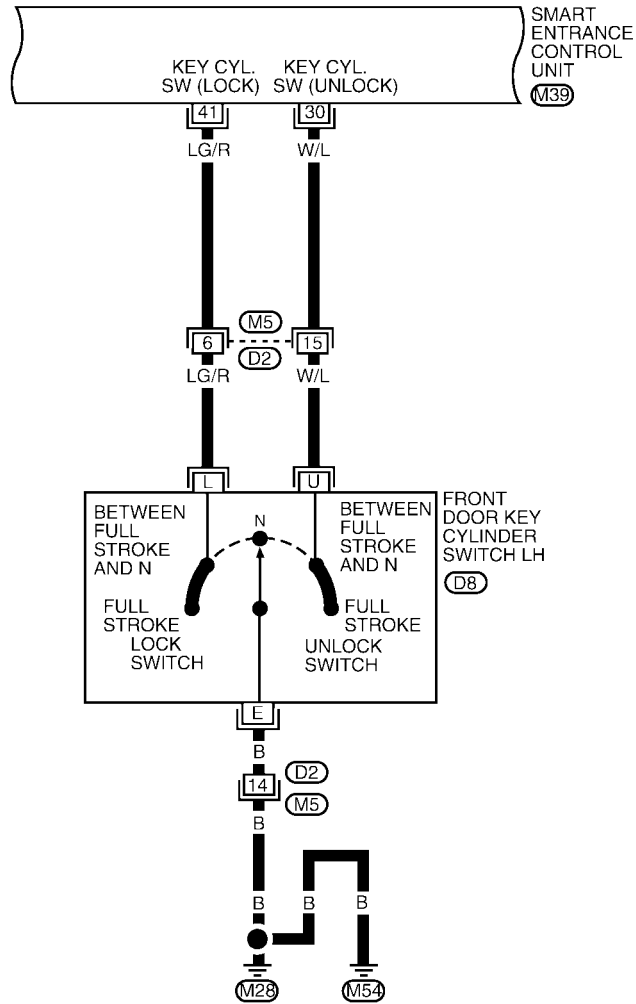

WIWA0067E

SMART ENTRANCE CONTROL UNIT TERMINALS AND REFERENCE VALUE MEASURED BETWEEN EACH TERMINAL AND GROUND

TERMINAL	WIRE COLOR	ITEM	CONDITION	DATA (DC)
30	W/L	DOOR KEY CYLINDER UNLOCK SWITCH	OFF (NEUTRAL)	5V
			ON (UNLOCKED)	0V
41	LG/R	DOOR KEY CYLINDER LOCK SWITCH	OFF (NEUTRAL)	5V
			ON (LOCKED)	0V

LEL607



# POWER DOOR LOCK

FIG. 3

BL-D/LOCK-03

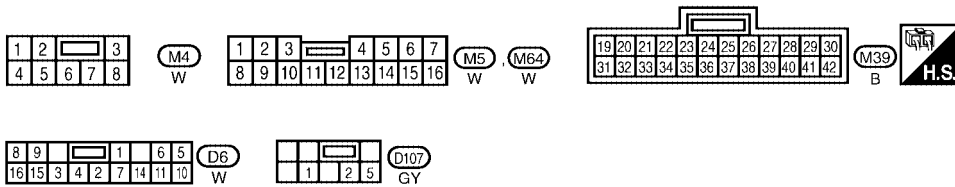
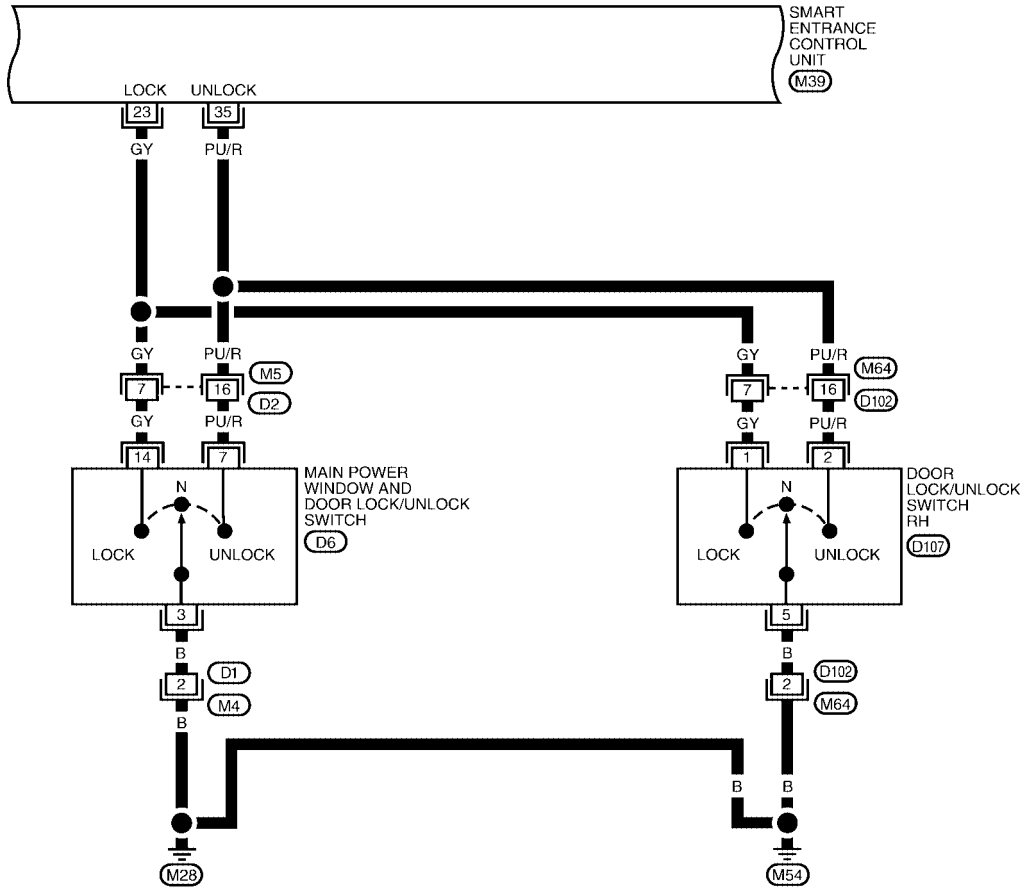

WIWA0021E

SMART ENTRANCE CONTROL UNIT TERMINALS AND REFERENCE VALUE MEASURED BETWEEN EACH TERMINAL AND GROUND

TERMINAL	WIRE COLOR	ITEM	CONDITION	DATA (DC)
23	GY	DOOR LOCK & UNLOCK SWITCHES	NEUTRAL	5V
			LOCKS	0V
35	PU/R	DOOR LOCK & UNLOCK SWITCHES	NEUTRAL	5V
			UNLOCKS	0V

LEL608

# POWER DOOR LOCK

FIG. 4

BL-D/LOCK-04

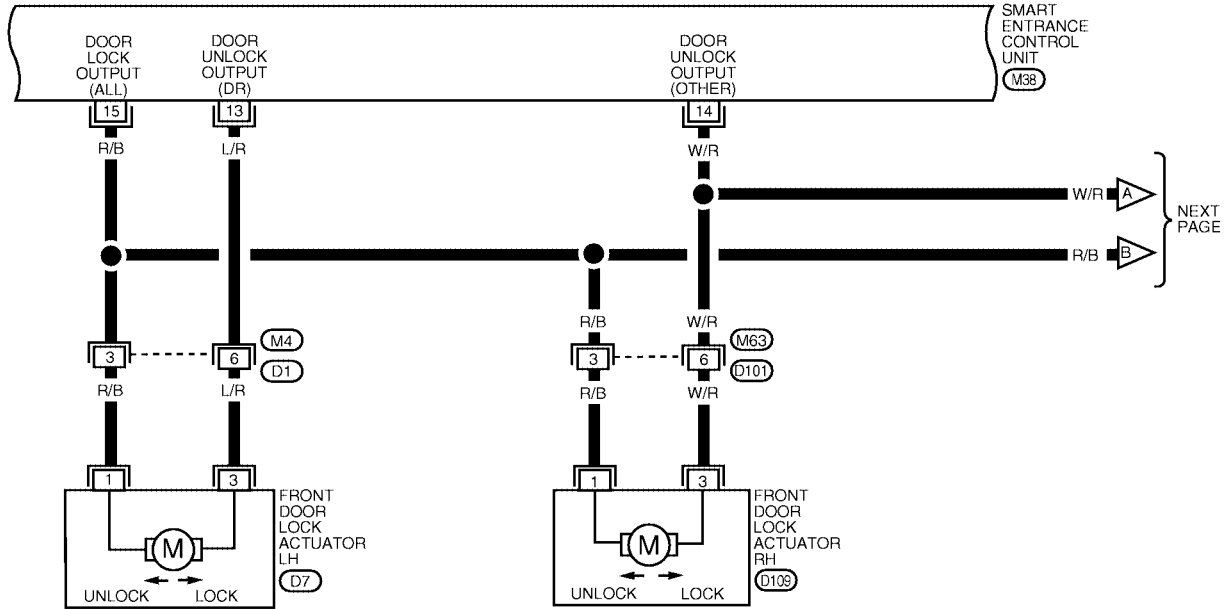

WIWA0022E

SMART ENTRANCE CONTROL UNIT TERMINALS AND REFERENCE VALUE MEASURED BETWEEN EACH TERMINAL AND GROUND

TERMINAL	WIRE COLOR	ITEM	CONDITION	DATA (DC)
13	L/R	DRIVER DOOR LOCK ACTUATOR	DOOR LOCK/ UNLOCK SWITCH (FREE)	0V
			DOOR LOCK/ UNLOCK SWITCH (UNLOCKED)	12V
14	W/R	PASSENGER AND REAR DOORS LOCK ACTUATORS	DOOR LOCK/ UNLOCK SWITCH (FREE)	0V
			DOOR LOCK/ UNLOCK SWITCH (UNLOCKED)	12V
15	R/B	DOOR LOCK ACTUATORS	DOOR LOCK/ UNLOCK SWITCH (FREE)	0V
			DOOR LOCK/ UNLOCK SWITCH (LOCKED)	12V
36	Y/G	DOOR UNLOCK SENSOR LH	DRIVER DOOR: LOCKED	5V
			DRIVER DOOR: UNLOCKED	0V

LEL609

# POWER DOOR LOCK

FIG. 5

BL-D/LOCK-05

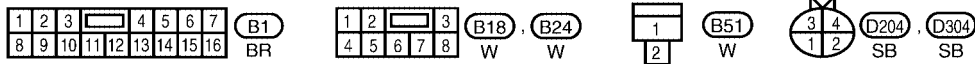
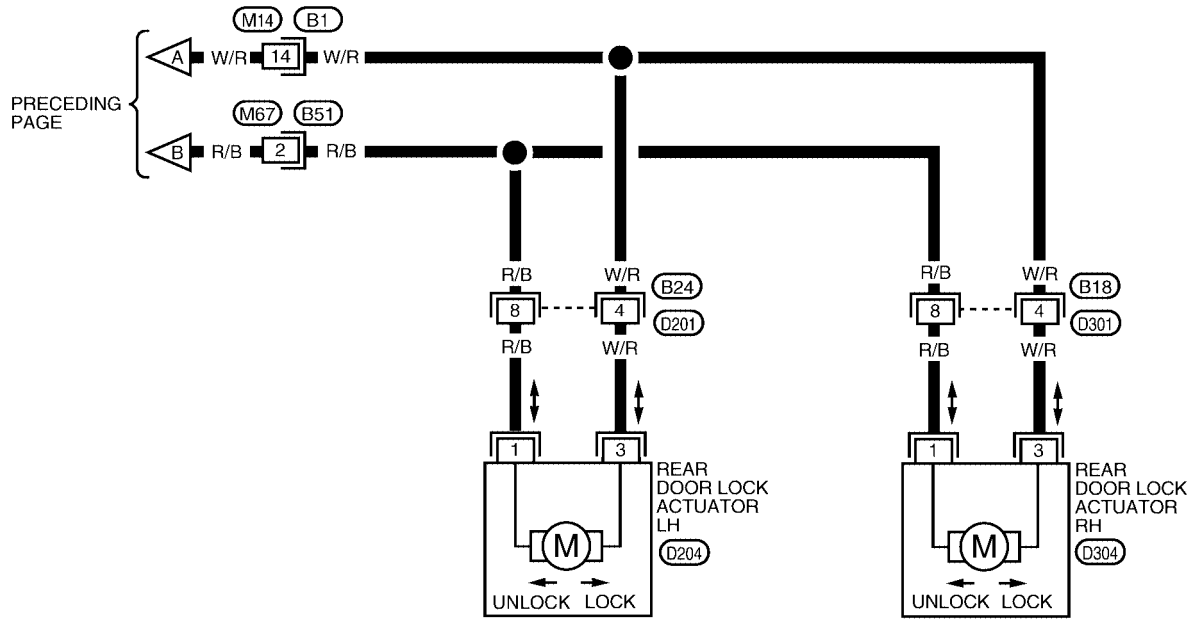

WIWA0068E

# POWER DOOR LOCK

EIS0014Y

## CONSULT-II Inspection Procedure "DOOR LOCK"

1. Turn ignition switch "OFF".

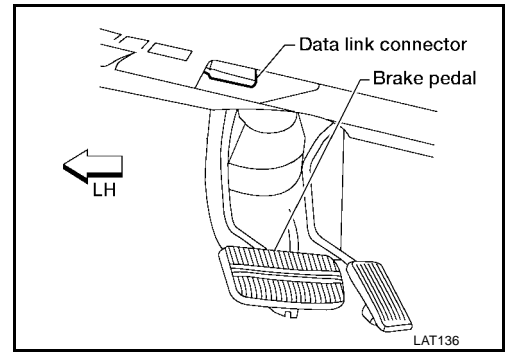

2. Connect "CONSULT-II" to the data link connector.

3. Turn ignition switch "ON".

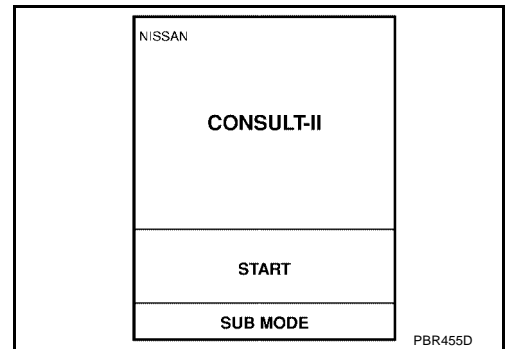

4. Touch "START".

5. Touch "SMART ENTRANCE".

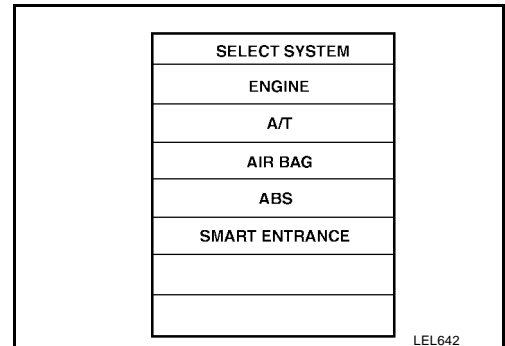

6. Touch "DOOR LOCK".

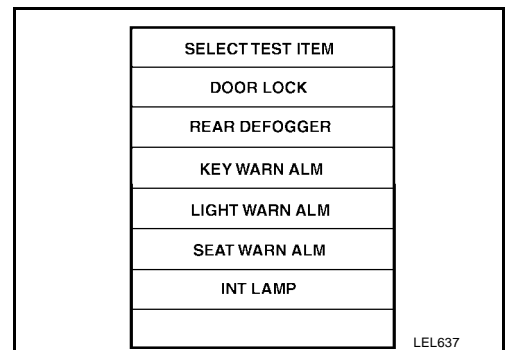

7. Select diagnosis mode.

# POWER DOOR LOCK

“DATA MONITOR” and “ACTIVE TEST” are available.

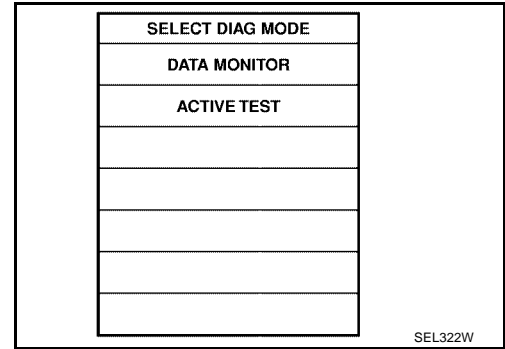

## CONSULT-II Application Items “DOOR LOCK”

EIS0014Z

### Data Monitor

Monitored Item	Description
KEY ON SW	Indicates [ON/OFF] condition of key switch.
LOCK SW DR/AS	Indicates [ON/OFF] condition of lock signal from lock/unlock switch LH and RH.
UNLK SW DR/AS	Indicates [ON/OFF] condition of unlock signal from lock/unlock switch LH and RH.
KEY CYL LK SW	Indicates [ON/OFF] condition of lock signal from key cylinder.
KEY CYL UN SW	Indicates [ON/OFF] condition of unlock signal from key cylinder.
DOOR SW-ALL	Indicates [ON/OFF] condition of door switch (All).
LK BUTTON/SIG	Indicates [ON/OFF] condition of lock signal from keyfob.
UN BUTTON/SIG	Indicates [ON/OFF] condition of unlock signal from keyfob.
UN BUTTON ON	Indicates [ON/OFF] condition of second unlock signal from keyfob within 5 seconds after first unlock operation.

### Active Test

Test Item	Description
ALL D/LK MTR	This test is able to check all door lock actuators lock operation. These actuators lock when “ON” on CONSULT-II screen is touched.
DR D/UN MTR	This test is able to check front door lock actuator LH unlock operation. The actuator unlocks when “ON” on CONSULT-II screen is touched.
NON DR D/UN	This test is able to check door lock actuators (except front door lock actuator LH) unlock operation. These actuators unlock when “ON” on CONSULT-II screen is touched.

A  
B  
C  
D  
E  
F  
G  
H  
BL  
J  
K  
L  
M

# POWER DOOR LOCK

## Trouble Diagnoses SYMPTOM CHART

EIS00150

REFERENCE PAGE (BL- )	<a href="#">BL-23</a>	<a href="#">BL-24</a>	<a href="#">BL-25</a>	<a href="#">BL-26</a>	<a href="#">BL-28</a>	<a href="#">BL-29</a>
SYMPTOM	MAIN POWER SUPPLY AND GROUND CIRCUIT CHECK	DOOR SWITCH CHECK	KEY SWITCH (INSERT) CHECK	DOOR LOCK/UNLOCK SWITCH CHECK	FRONT DOOR KEY CYLINDER SWITCH CHECK	DOOR LOCK ACTUATOR CHECK
Key reminder door system does not operate properly.	X	X	X			X
Specific door lock actuator does not operate.	X					X
Power door lock does not operate with door lock and unlock switch (LH and RH) on door trim.	X			X		
Power door lock does not operate with front door key cylinder operation.	X				X	

X: Applicable

# POWER DOOR LOCK

## MAIN POWER SUPPLY AND GROUND CIRCUIT CHECK

### Main Power Supply Circuit Check

Terminals		Ignition switch position		
(+)	(-)	OFF	ACC	ON
10	Ground	Battery voltage	Battery voltage	Battery voltage
11				

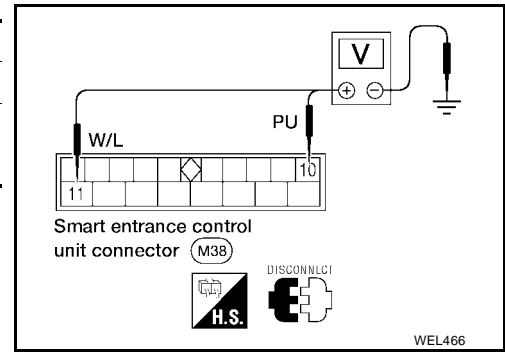

### Ground Circuit Check

Terminals	Continuity
16 - Ground	Yes

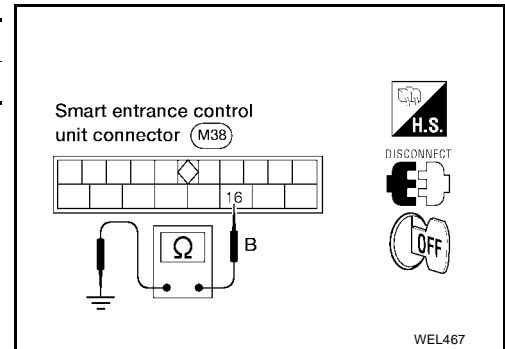

A  
B  
C  
D  
E  
F  
G  
H  
J  
K  
L  
M

BL

# POWER DOOR LOCK

## DOOR SWITCH CHECK

### 1. CHECK DOOR SWITCHES INPUT SIGNAL

#### Ⓜ With CONSULT-II

Check door switches ("DOOR SW-ALL") in "DATA MONITOR" mode with CONSULT-II.

DATA MONITOR	
MONITOR	
DOOR SW-ALL	OFF

When any doors are open:  
**DOOR SW-ALL ON**

When all doors are closed:  
**DOOR SW-ALL OFF**

SEL323W

#### ⊗ Without CONSULT-II

Check voltage between smart entrance control unit harness connector terminals 28 or 29 and ground.

Smart entrance control unit connector (M39)

R/W R

	Terminals		Condition	Voltage [V]
	(+)	(-)		
Front door switch LH	29	Ground	Open	0
		Ground	Closed	Approx. 5
Other door switches	28	Ground	Open	0
		Ground	Closed	Approx. 5

WEL500

Refer to [BL-15, "FIG. 1"](#).

#### OK or NG

- OK >> Door switch is OK.
- NG >> GO TO 2.

### 2. CHECK DOOR SWITCHES

1. Disconnect door switch harness connector.
2. Check continuity between door switch connector terminals.

Front door switch LH connector (B23)

Front door switch RH connector (B17)

Rear door switch connector

LH: (B26)

RH: (B32)

	Terminals	Condition	Continuity
Front door switch LH	2 - 3	Closed	No
		Open	Yes
Front door switch RH	1 - Ground	Closed	No
		Open	Yes
Rear door switches	(+) - Ground	Closed	No
		Open	Yes

WEL491

#### OK or NG

- OK >> Check the following.
  - Door switch ground circuit or door switch ground condition
  - Harness for open or short between smart entrance control unit and door switch
- NG >> Replace door switch.



# POWER DOOR LOCK

## KEY SWITCH (INSERT) CHECK

### 1. CHECK KEY SWITCH INPUT SIGNAL

#### With CONSULT-II

Check key switch ("KEY ON SW") in "DATA MONITOR" mode with CONSULT-II.

DATA MONITOR	
MONITOR	
KEY ON SW	ON

When key is inserted to ignition key cylinder:  
**KEY ON SW ON**

When key is removed from ignition key cylinder:  
**KEY ON SW OFF**

SEL315W

#### Without CONSULT-II

Check voltage between smart entrance control unit harness connector terminal 32 and ground.

Smart entrance control unit connector (M39)

CONNECT

H.S.

Voltage [V]:  
Condition of key switch: Key is inserted.  
Approx. 12  
Condition of key switch: Key is removed.  
0

LEL454

Refer to [BL-15, "FIG. 1"](#).

OK or NG

- OK >> Key switch is OK.
- NG >> GO TO 2.

### 2. CHECK KEY SWITCH

Check continuity between key switch connector terminals 1 and 2.

Key switch connector (E113)

T.S.

DISCONNECT

Continuity:  
Condition of key switch: Key is inserted.  
Yes  
Condition of key switch: Key is removed.  
No

LEL449

OK or NG

- OK >> Check the following.
  - 10A fuse [No. 12, located in fuse block (J/B)]
  - Harness for open or short between key switch and fuse
  - Harness for open or short between smart entrance control unit and key switch
- NG >> Replace key switch.

# POWER DOOR LOCK

## DOOR LOCK/UNLOCK SWITCH CHECK

### 1. CHECK DOOR LOCK/UNLOCK SWITCH INPUT SIGNAL

#### ⓑ With CONSULT-II

Check door lock/unlock switch ("LOCK SW DR/AS"/"UNLK SW DR/AS") in "DATA MONITOR" mode with CONSULT-II.

DATA MONITOR	
MONITOR	
LOCK SW DR/AS	OFF
UNLK SW DR/AS	OFF

When lock/unlock switch is turned to LOCK:  
**LOCK SW DR/AS ON**

When lock/unlock switch is turned to UNLOCK:  
**UNLK SW DR/AS ON**

SEL341W

#### ⓧ Without CONSULT-II

1. Disconnect smart entrance control unit harness connector.
2. Check continuity between smart entrance control unit harness connector terminal 23 or 35 and ground.

Smart entrance control unit connector (M39)

DISCONNECT

Terminals	Door lock/unlock switch (LH or RH) condition	Continuity
23 - Ground	Lock	Yes
	N and Unlock	No
35 - Ground	Unlock	Yes
	N and Lock	No

WEL501

Refer to [BL-17, "FIG. 3"](#) .

#### OK or NG

- OK >> Door lock/unlock switch is OK.  
 NG >> GO TO 2.

# POWER DOOR LOCK

## 2. CHECK DOOR LOCK/UNLOCK SWITCH

1. Disconnect door lock/unlock switch harness connector.
2. Check continuity between each door lock/unlock switch terminals.
  - Main power window and door lock/unlock switch



DISCONNECT

Main power window and door lock/unlock switch connector (D6)

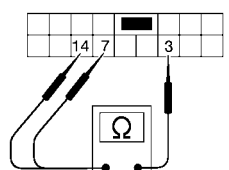

Condition	Terminals		
	3	7	14
Lock	○	○	○
N	No continuity		
Unlock	○	○	○

WEL494

- Door lock/unlock switch RH



DISCONNECT

Door lock/unlock switch RH connector (D107)

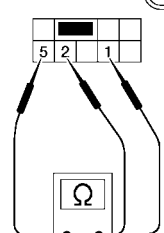

Condition	Terminals		
	1	2	5
Lock	○	○	○
N	No continuity		
Unlock	○	○	○

WEL495

### OK or NG

- OK >> Check the following.
- Ground circuit for door lock/unlock switch
  - Harness for open or short between door lock/unlock switch and smart entrance control unit connector
- NG >> Replace door lock/unlock switch.

# POWER DOOR LOCK

## FRONT DOOR KEY CYLINDER SWITCH CHECK

### 1. CHECK FRONT DOOR KEY CYLINDER SWITCH INPUT SIGNAL (LOCK/UNLOCK SIGNAL)

#### Ⓜ With CONSULT-II

Check front door key cylinder switch ("KEY CYL LK-SW"/"KEY CYL UN-SW") in "DATA MONITOR" mode with CONSULT-II.

DATA MONITOR	
MONITOR	
KEY CYL LK-SW	OFF
KEY CYL UN-SW	OFF

When key inserted in front key cylinder is turned to LOCK:  
**KEY CYL LK-SW ON**

When key inserted in front key cylinder is turned to UNLOCK:  
**KEY CYL UN-SW ON**

SEL342W

#### ⊗ Without CONSULT-II

Check voltage between smart entrance control unit harness connector terminals 30 or 41 and ground.

Smart entrance control unit connector (M39)

Terminals		Key position	Voltage [V]
(+)	(-)		
41	Ground	Neutral/Unlock	Approx. 5
		Lock	0
30	Ground	Neutral/Lock	Approx. 5
		Unlock	0

WEL502

Refer to [BL-16, "FIG. 2"](#).

#### OK or NG

- OK >> Door key cylinder switch is OK.
- NG >> GO TO 2.

### 2. CHECK DOOR KEY CYLINDER SWITCH

1. Disconnect door key cylinder switch harness connector.
2. Check continuity between door key cylinder switch connector D8 terminals L, E, and U, E.

Front door key cylinder switch LH connector

Ⓜ : Ground terminal  
Ⓧ : Door unlock switch terminal  
Ⓛ : Door lock switch terminal

Terminals	Key position	Continuity
Ⓛ - Ⓜ	Neutral/Unlock	No
	Lock	Yes
Ⓧ - Ⓜ	Neutral/Lock	No
	Unlock	Yes

LEL101A

#### OK or NG

- OK >> Check the following.
  - Door key cylinder switch ground circuit
  - Harness for open or short between smart entrance control unit and door key cylinder switch
- NG >> Replace door key cylinder switch.

# POWER DOOR LOCK

## DOOR LOCK ACTUATOR CHECK

### 1. CHECK DOOR LOCK ACTUATOR OPERATION

#### With CONSULT-II

1. Select "ACTIVE TEST" in "DOOR LOCK" with CONSULT-II.
2. Select "ALL D/LK MTR" and touch "ON".
3. Then, select "DR D/UN MTR" and touch "ON".
4. Select "NON DR D/UN" and touch "ON".

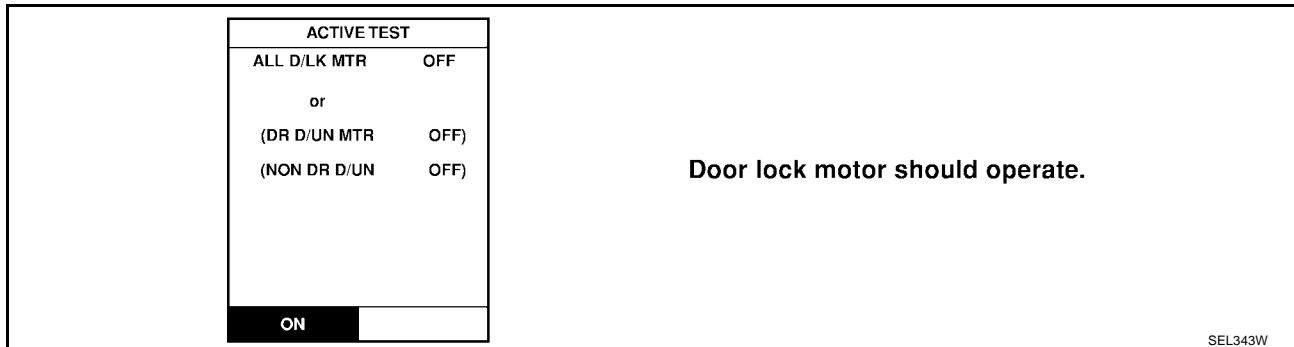

#### NOTE:

If CONSULT-II is not available, skip this procedure and go to the next step.

#### OK or NG

- OK >> Door lock actuator is OK.
- NG >> GO TO 2.

# POWER DOOR LOCK

## 2. CHECK DOOR LOCK ACTUATOR CIRCUIT

Check voltage for door lock actuator.

- Door lock actuator front LH

Door lock/unlock switch condition	Terminals		Voltage [V]
	(+)	(-)	
Lock	15	Ground	Approx. 12
Unlock	13	Ground	

WEL504

- Door lock actuator front RH and rear

Door lock/unlock switch condition	Terminals		Voltage [V]
	(+)	(-)	
Lock	15	Ground	Approx. 12
Unlock	14	Ground	

WEL505

Refer to [BL-18, "FIG. 4"](#) .

OK or NG

OK >> GO TO 3.

NG >> Replace smart entrance control unit. (Before replacing the smart entrance control unit, perform [BL-26, "DOOR LOCK/UNLOCK SWITCH CHECK"](#) .)

## 3. CHECK DOOR LOCK ACTUATOR

1. Disconnect door lock actuator harness connector.
2. Apply 12V direct current to door lock actuator and check operation.

Door lock actuator connector

- Front LH : (D7)
- Front RH : (D109)
- Rear LH : (D204)
- Rear RH : (D304)

**Door lock actuator operation:**

Terminals between (+): 1 and (-): 3	Unlocked → Locked
Terminals between (+): 3 and (-): 1	Locked → Unlocked

WEL499

OK or NG

OK >> Check harness for open or short between smart entrance control unit connector and door lock actuator.

NG >> Replace door lock actuator.

# DOOR

## DOOR

PFP:80100

### Front Door

EIS00151

- For removal of door finisher, refer to [EI-31, "Removal and Installation"](#).
- After adjusting the door or door lock, check the door lock operation.

SEC. 800-803-805

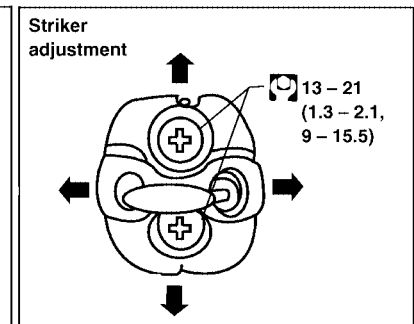
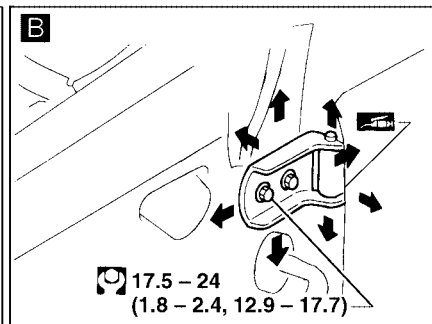
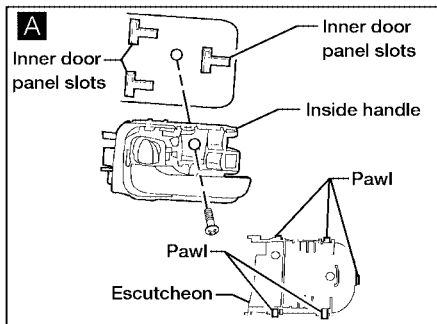
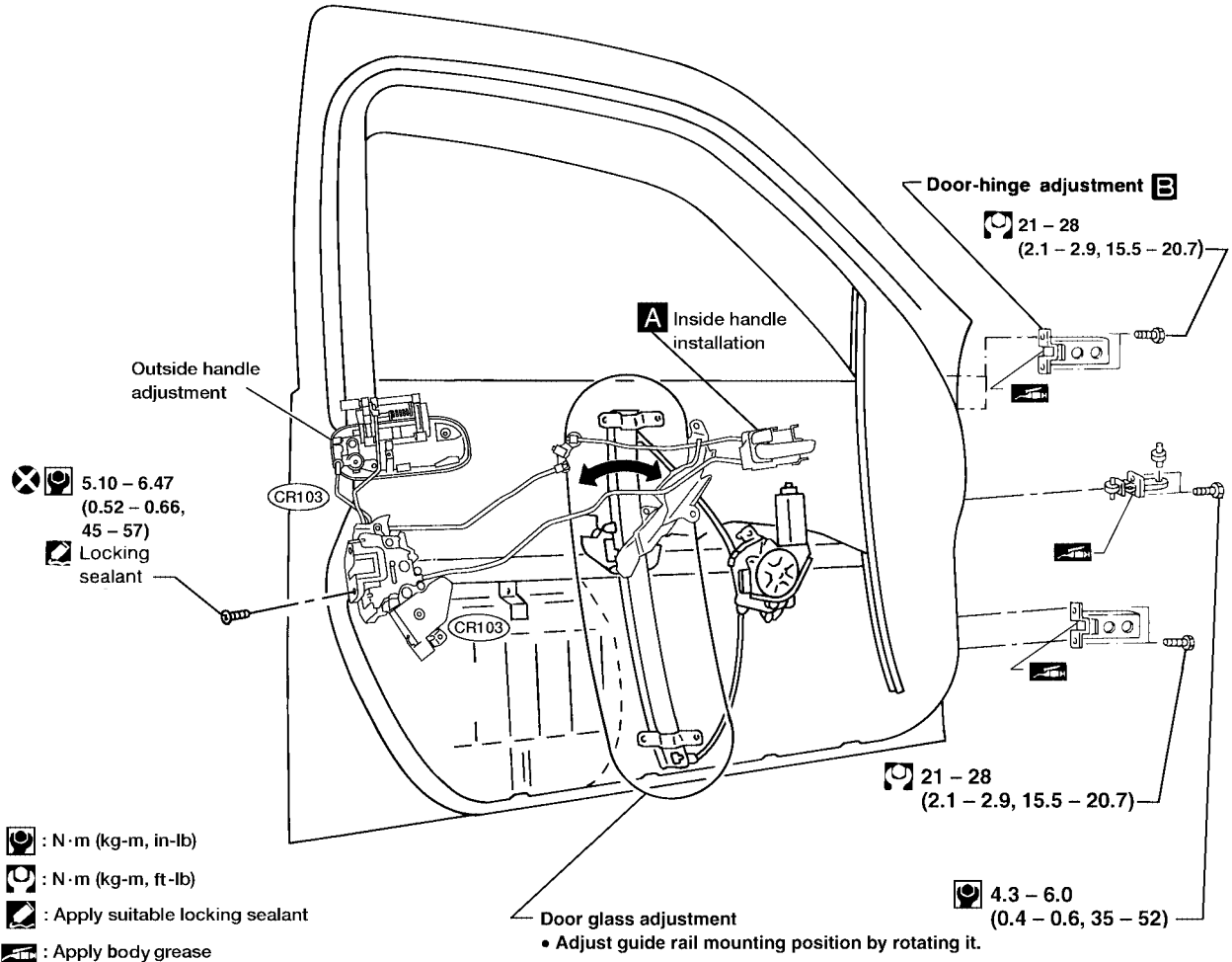

### Rear Door

- For removal of door finisher, refer to [EI-31, "Removal and Installation"](#).

WIIA0006E

EIS00152

# DOOR

- After adjusting the door or door lock, check the door lock operation.

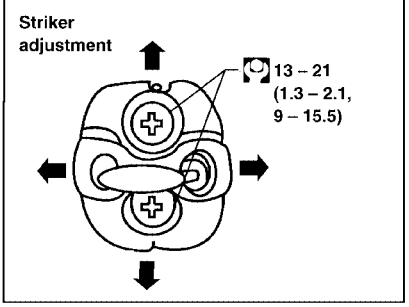
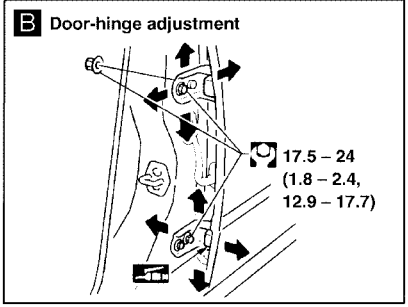
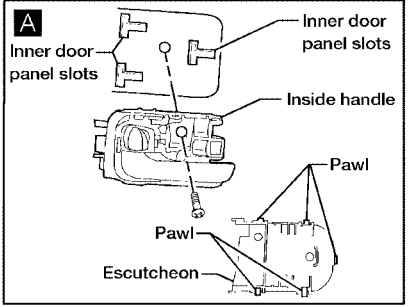
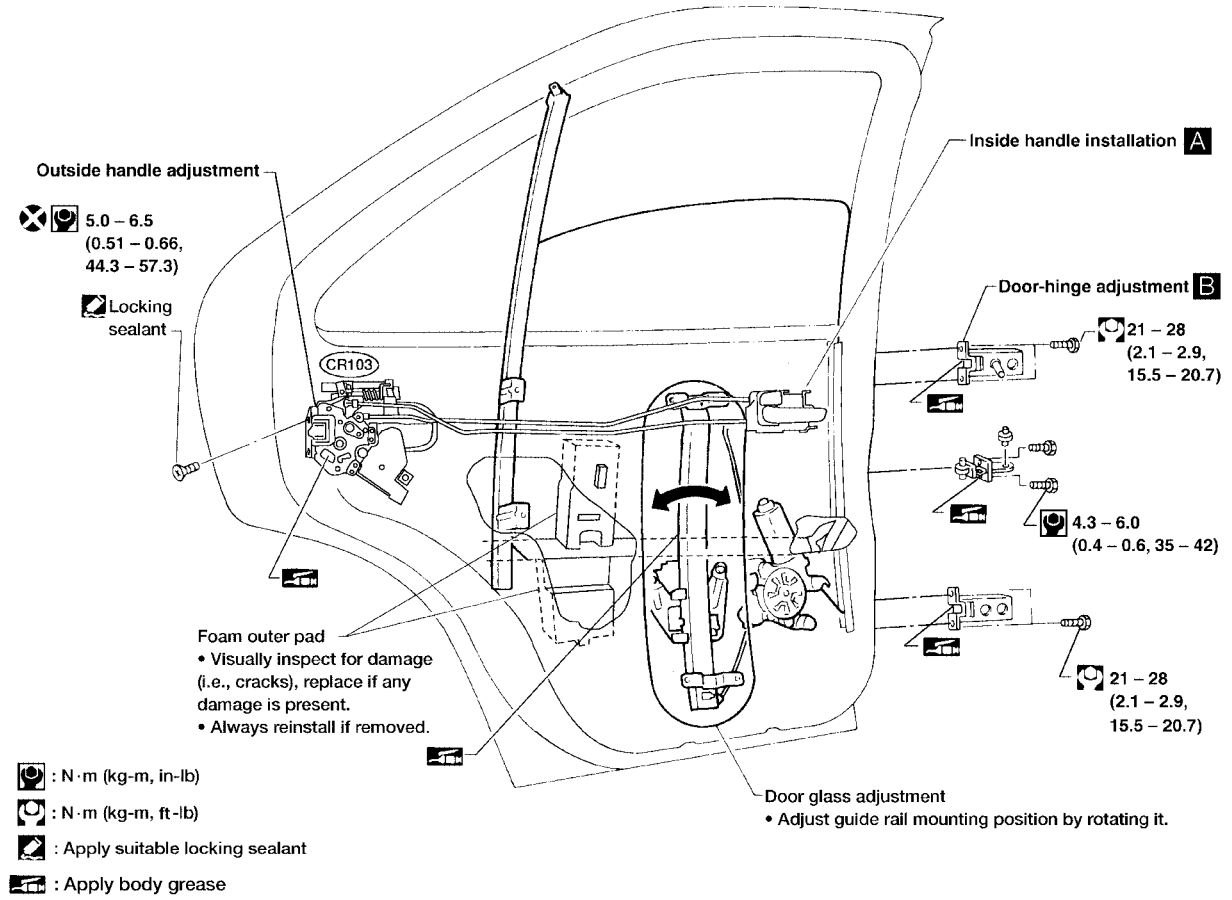

W1IA0002E



# TRUNK LID OPENER

PFP:84640

## TRUNK LID OPENER

### Wiring Diagram — TLID —

EIS00153

BL-TLID-01

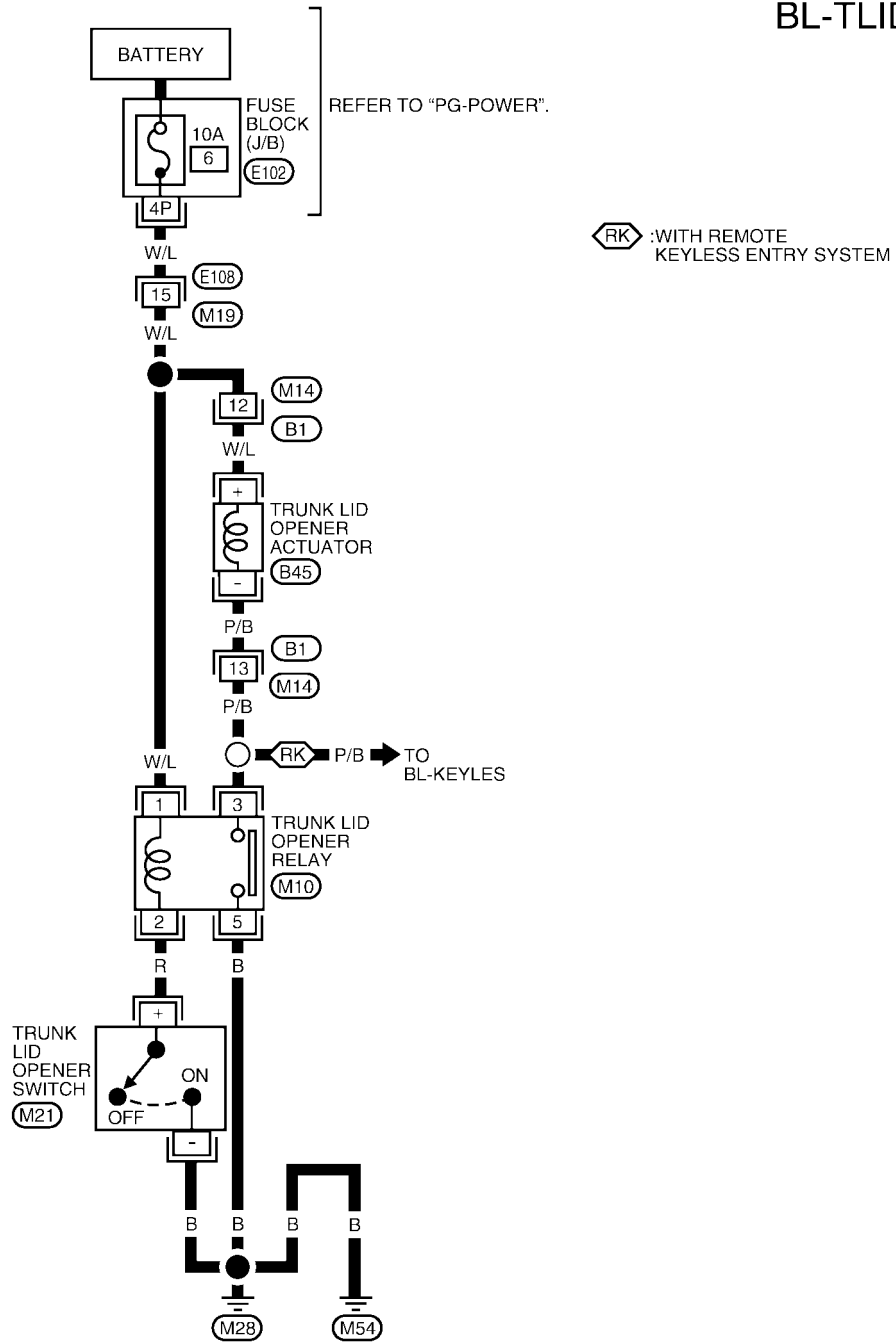

A  
B  
C  
D  
E  
F  
G  
H  
BL  
J  
K  
L  
M

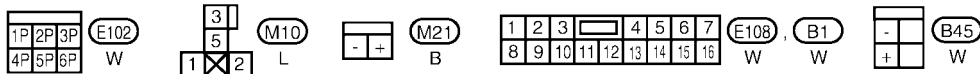

WIWA0077E

# REMOTE KEYLESS ENTRY SYSTEM

PF2:28596

## REMOTE KEYLESS ENTRY SYSTEM

### Component Parts and Harness Connector Location

EIS00154

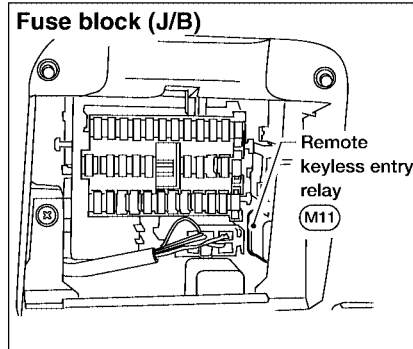
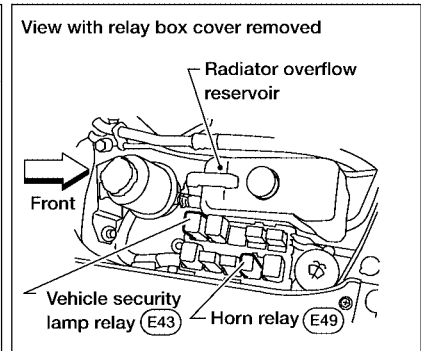
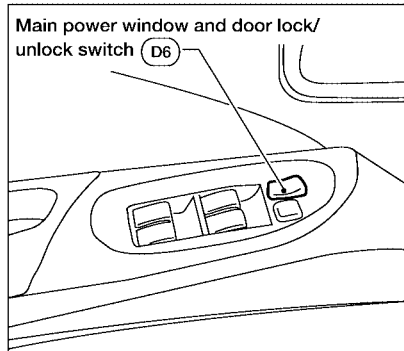
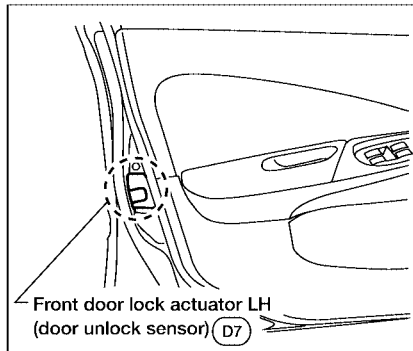
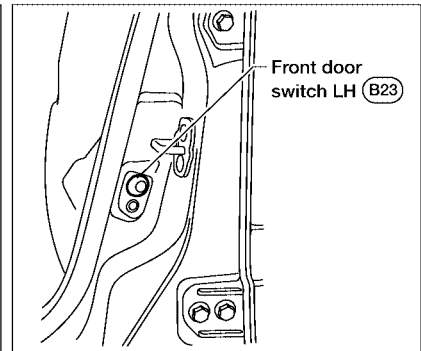
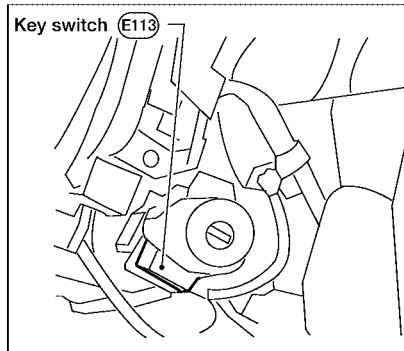
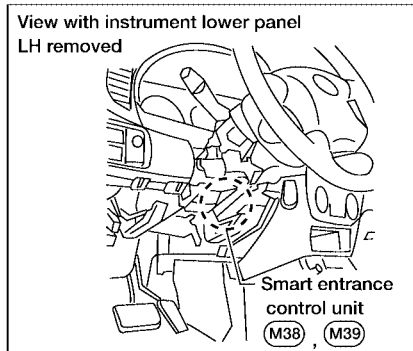
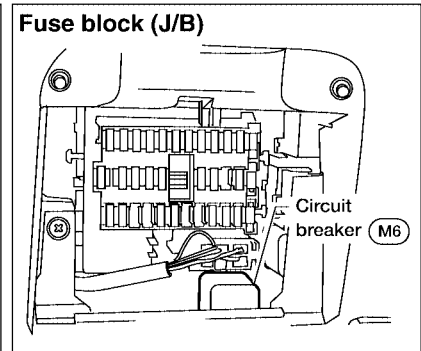
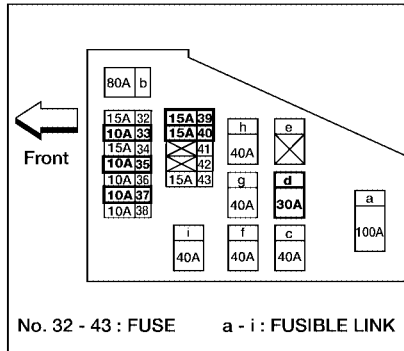
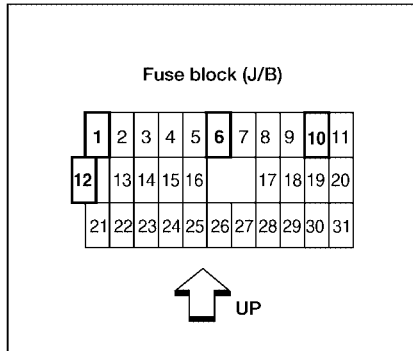

W1IA0007E

# REMOTE KEYLESS ENTRY SYSTEM

EIS00155

## System Description

### INPUTS

Power is supplied at all times:

- to key switch terminal 2
- through 10A fuse [No. 12, located in the fuse block (J/B)].

When the key switch is ON (ignition key is inserted in key cylinder), power is supplied:

- through key switch terminal 1
- to smart entrance control unit terminal 32.

When the front door switch LH is ON (door is OPEN), ground is supplied:

- to smart entrance control unit terminal 29
- through front door switch LH terminal 2
- to front door switch LH terminal 3
- through body grounds B13 and B19.

When the front door switch RH and rear door switches are ON (doors are OPEN), ground is supplied:

- to smart entrance control unit terminal 28
- through front door switch RH terminal 1 and rear door switches terminal +
- to front door switch RH case ground and rear door switches case grounds.

When main power window and door lock/unlock switch is LOCKED, ground is supplied:

- to smart entrance control unit terminal 23
- through main power window and door lock/unlock switch terminal 14 and
- through body grounds M28 and M54.

When main power window and door lock/unlock switch is UNLOCKED, ground is supplied:

- to smart entrance control unit terminal 35
- through main power window and door lock/unlock switch terminal 7 and
- through body grounds M28 and M54.

When front door unlock sensor LH is UNLOCKED, ground is supplied:

- to smart entrance control unit terminal 36
- through front door unlock sensor LH terminal 2
- to front door unlock sensor LH terminal 4
- through body grounds M28 and M54.

Keyfob signal is input to smart entrance control unit (the antenna of the system is combined with smart entrance control unit).

The remote keyless entry system controls operation of the:

- power door locks
- trunk lid opener
- interior lamp
- panic alarm
- hazard and horn reminder.

### OPERATED PROCEDURE

#### Power Door Lock Operation

Smart entrance control unit receives a LOCK signal from keyfob. Smart entrance control unit locks all doors with input of LOCK signal from keyfob.

When an UNLOCK signal is sent from keyfob once, driver door will be unlocked.

Then, if an UNLOCK signal is sent from keyfob again within 5 seconds, all other doors will be unlocked.

#### Hazard and Horn Reminder

Power is supplied at all times:

- to remote keyless entry relay terminals 1, 3 and 6
- through 15A fuse [No. 5, located in the fuse block (J/B)], and
- to horn relay terminals 1 and 5

A

B

C

D

E

F

G

H

BL

J

K

L

M

# REMOTE KEYLESS ENTRY SYSTEM

- through 10A fuse (No. 33, located in the fuse and fusible link box).

When smart entrance control unit receives LOCK or UNLOCK signal from keyfob, ground is supplied:

- to remote keyless entry relay terminal 2
- through smart entrance control unit terminal 7, and
- to horn relay terminal 2
- through smart entrance control unit terminal 19.

Remote keyless entry relay and horn relay are now energized, and hazard warning lamp flashes and horn sounds as a reminder.

The hazard and horn reminder has C mode (horn chirp mode) and S mode (non-horn chirp mode).

## Operating function of hazard and horn reminder

	C mode (Horn chirp mode)		S mode (Non-horn chirp mode)	
	Hazard warning lamp flash	Horn sound	Hazard warning lamp flash	Horn sound
Lock	Twice	Once	Twice	—
Unlock	Once	—	—	—

## How to change hazard and horn reminder mode

④ With CONSULT-II

Hazard and horn reminder can be changed using “WORK SUPPORT” mode in “MULTI REMOTE ENT”.

⊗ Without CONSULT-II

When LOCK and UNLOCK signals are sent from the keyfob for more than 2 seconds at the same time, the hazard and horn reminder mode is changed and hazard warning lamp flashes and horn sounds as follows:

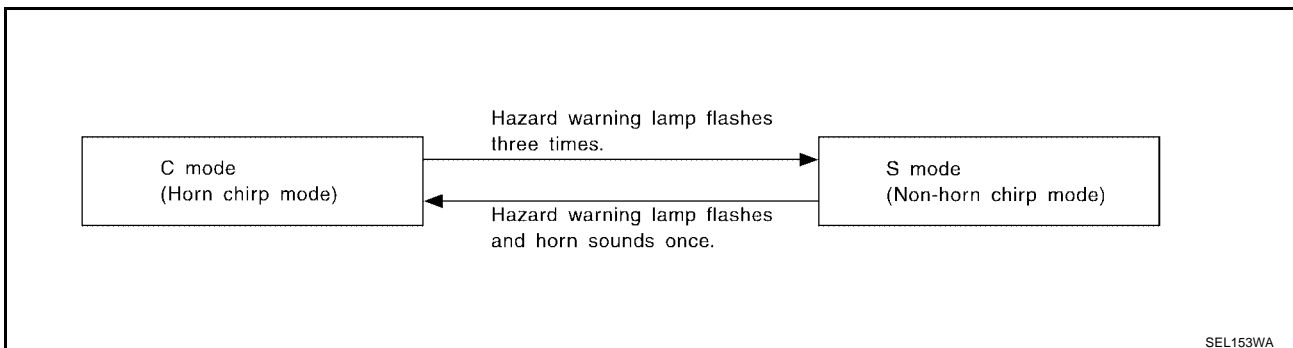

## Interior Lamp Operation

When the following input signals are both supplied:

- front door switch LH CLOSED (when driver door is closed);
- driver door LOCKED;

remote keyless entry system turns on interior lamp (for 30 seconds) with input of UNLOCK signal from keyfob. For detailed description, refer to [LT-35, "INTERIOR, MAP, VANITY AND TRUNK ROOM LAMPS"](#) .

## Panic Alarm Operation

When key switch is OFF (when ignition key is not inserted in key cylinder), remote keyless entry system turns on and off horn and headlamp intermittently with input of PANIC ALARM signal from keyfob.

The alarm automatically turns off after 25 seconds or when smart entrance control unit receives any signal from keyfob.

For detailed description, refer to [BL-69, "PANIC ALARM OPERATION"](#) .

## Trunk Lid Operation

Power is supplied at all times:

- through 10A fuse [No. 6, located in the fuse block (J/B)]
- to trunk lid opener actuator terminal +.

When a TRUNK OPEN signal is sent with key OFF (ignition key removed from key cylinder) from keyfob, ground is supplied:

- to trunk lid opener actuator terminal -

# REMOTE KEYLESS ENTRY SYSTEM

---

- through smart entrance control unit terminal 12.

Then power and ground are supplied, trunk lid opener actuator opens trunk lid.

A

B

C

D

E

F

G

H

**BL**

J

K

L

M

# REMOTE KEYLESS ENTRY SYSTEM

EIS00156

## Schematic

U : FOR USA  
N : FOR CANADA

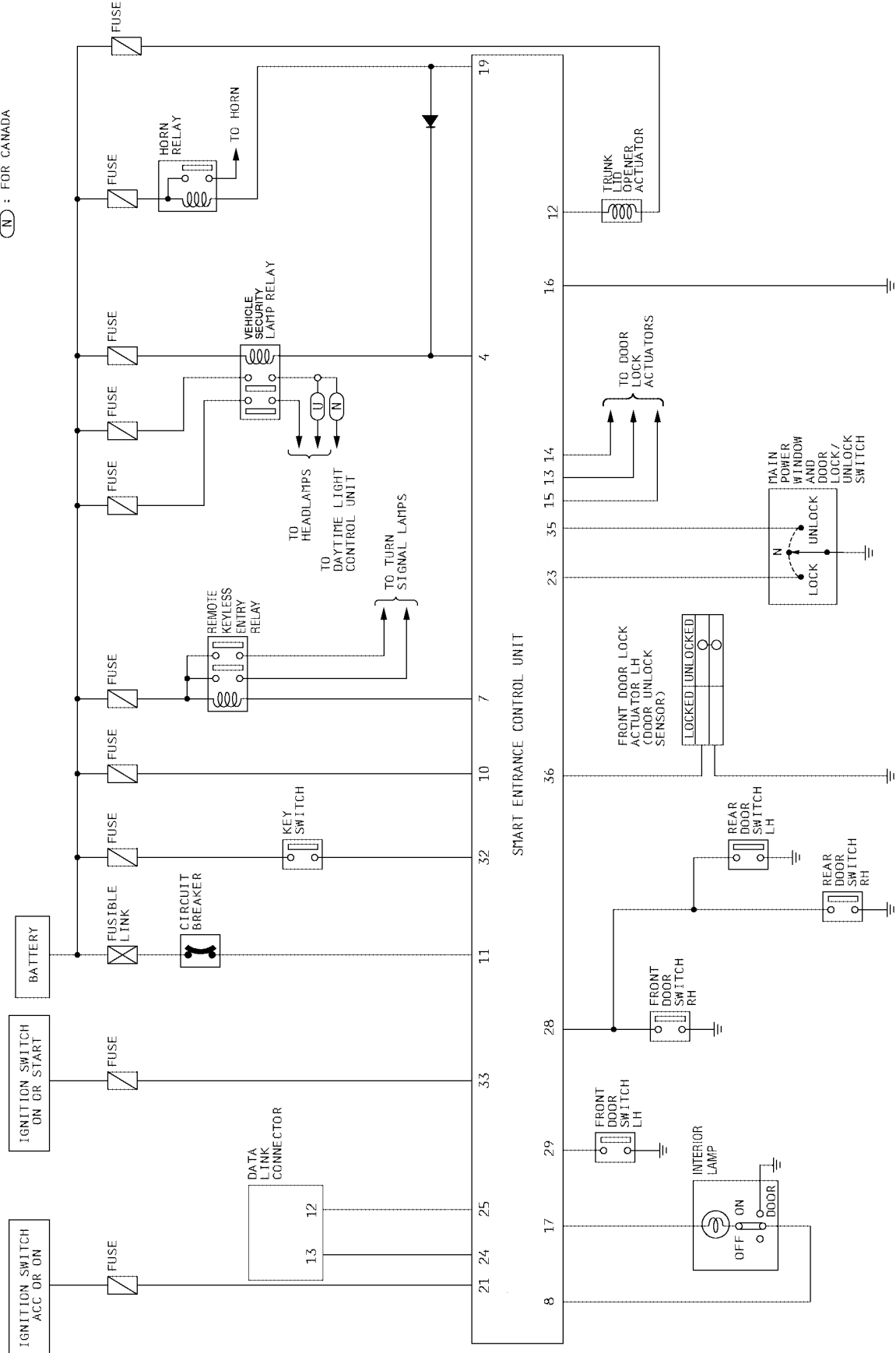

WIWA0069E

# REMOTE KEYLESS ENTRY SYSTEM

EIS00157

## Wiring Diagram — KEYLES — FIG. 1

BL-KEYLES-01

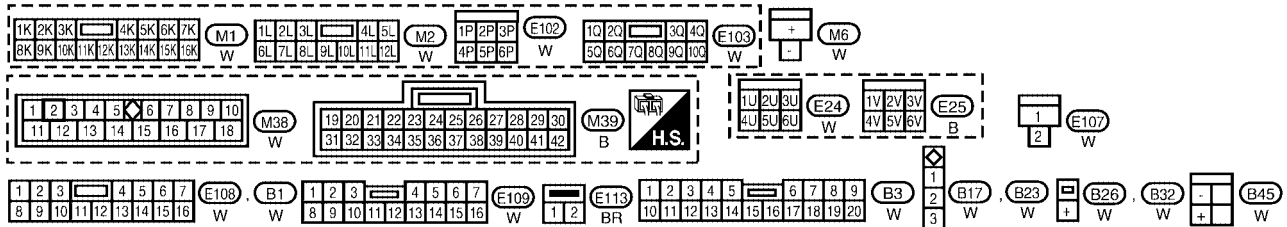
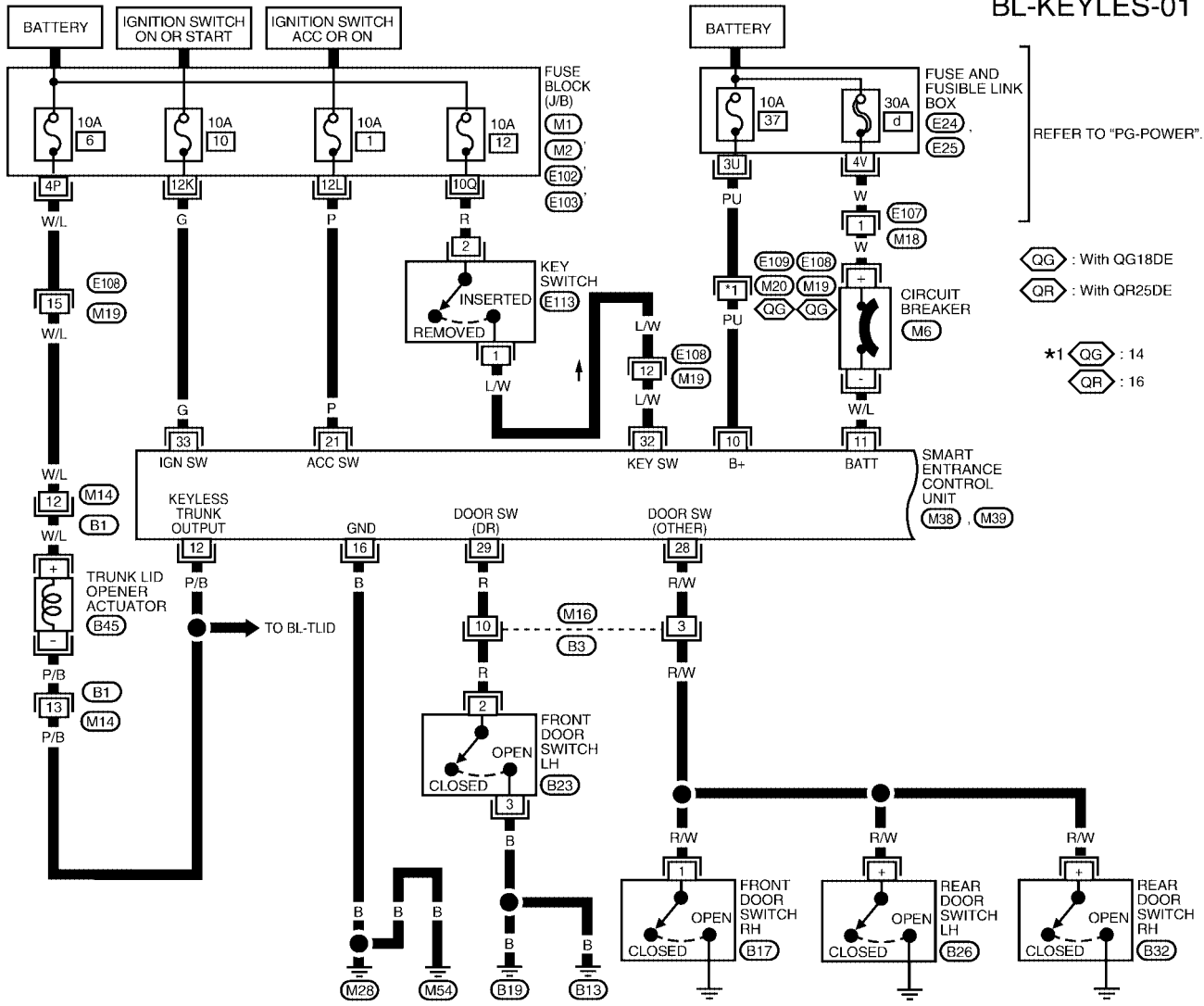

WIWA0070E

TERMINAL	WIRE COLOR	ITEM	CONDITION	DATA (DC)
10	PU	POWER SOURCE (FUSE)	---	12V
11	W/L	POWER SOURCE (CIRCUIT BREAKER)	---	12V
12	P/B	TRUNK LID OPENER ACTUATOR	ON (OPEN) OFF (CLOSED)	0V 12V
16	B	GROUND	---	---
21	P	IGNITION SWITCH (ACC, ON)	ACC OR ON POSITION	12V
28	R/W	OTHER DOOR SWITCHES	OFF (CLOSED) ON (OPEN)	5V 0V
29	R	FRONT DOOR SWITCH LH	OFF (CLOSED) ON (OPEN)	5V 0V
32	L/W	IGNITION KEY SWITCH (INSERT)	IGNITION KEY IS INSERTED IGNITION KEY IS REMOVED	12V 0V
33	G	IGNITION SWITCH (ON) IGNITION SWITCH (START)	IGNITION KEY IS IN ON POSITION IGNITION KEY IS IN START POSITION	12V 12V

LEL610

# REMOTE KEYLESS ENTRY SYSTEM

FIG. 2

BL-KEYLES-02

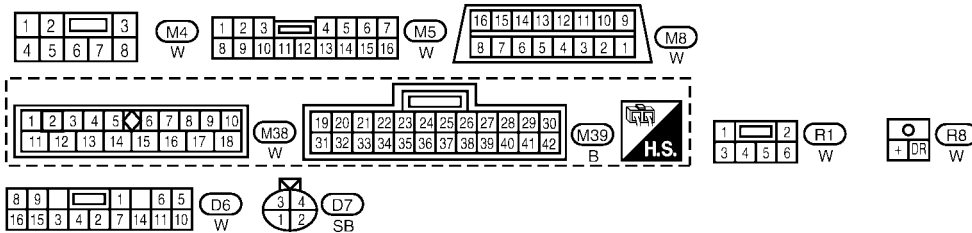
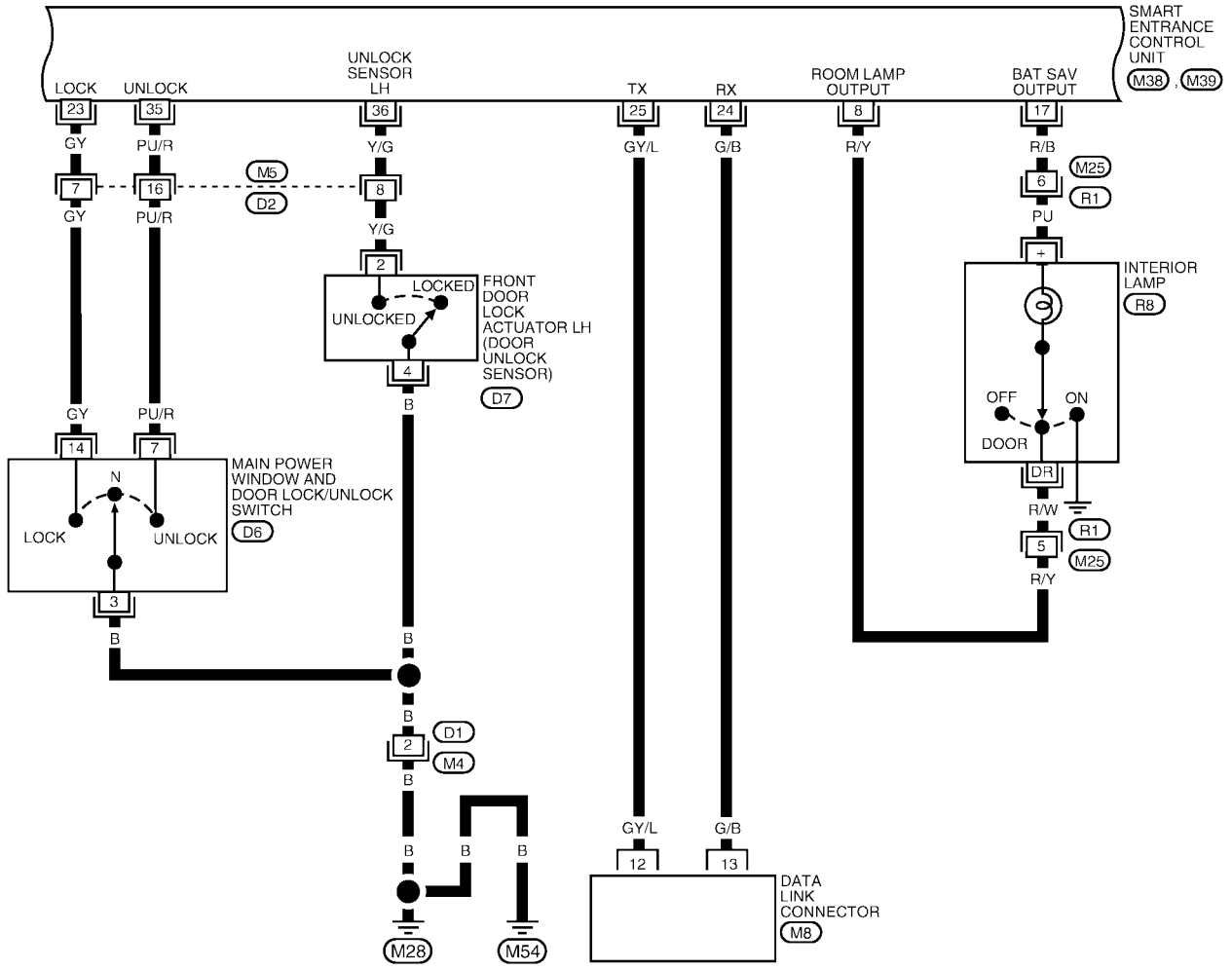

WIWA0071E

SMART ENTRANCE CONTROL UNIT TERMINALS AND REFERENCE VALUE MEASURED BETWEEN EACH TERMINAL AND GROUND

TERMINAL	WIRE COLOR	ITEM	CONDITION	DATA (DC)
8	R/Y	INTERIOR LAMP	LAMP SWITCH IN DOOR POSITION	12V
17	R/B	BATTERY SAVER (INTERIOR LAMP)	BATTERY SAVER DOES NOT OPERATE	12V
			BATTERY SAVER OPERATES	0V
23	GY	DOOR LOCK & UNLOCK SWITCHES	NEUTRAL	5V
			LOCKS	0V
35	PU/R	DOOR LOCK & UNLOCK SWITCHES	NEUTRAL	5V
			UNLOCKS	0V
36	Y/G	DOOR UNLOCK SENSOR LH	DRIVER DOOR: LOCKED	5V
			DRIVER DOOR: UNLOCKED	0V

LEL611



# REMOTE KEYLESS ENTRY SYSTEM

FIG. 3

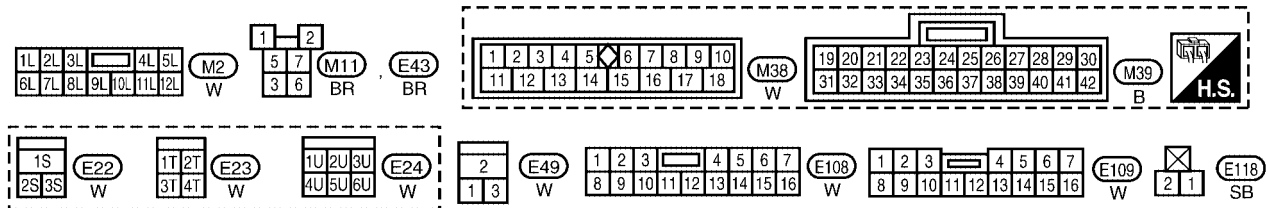
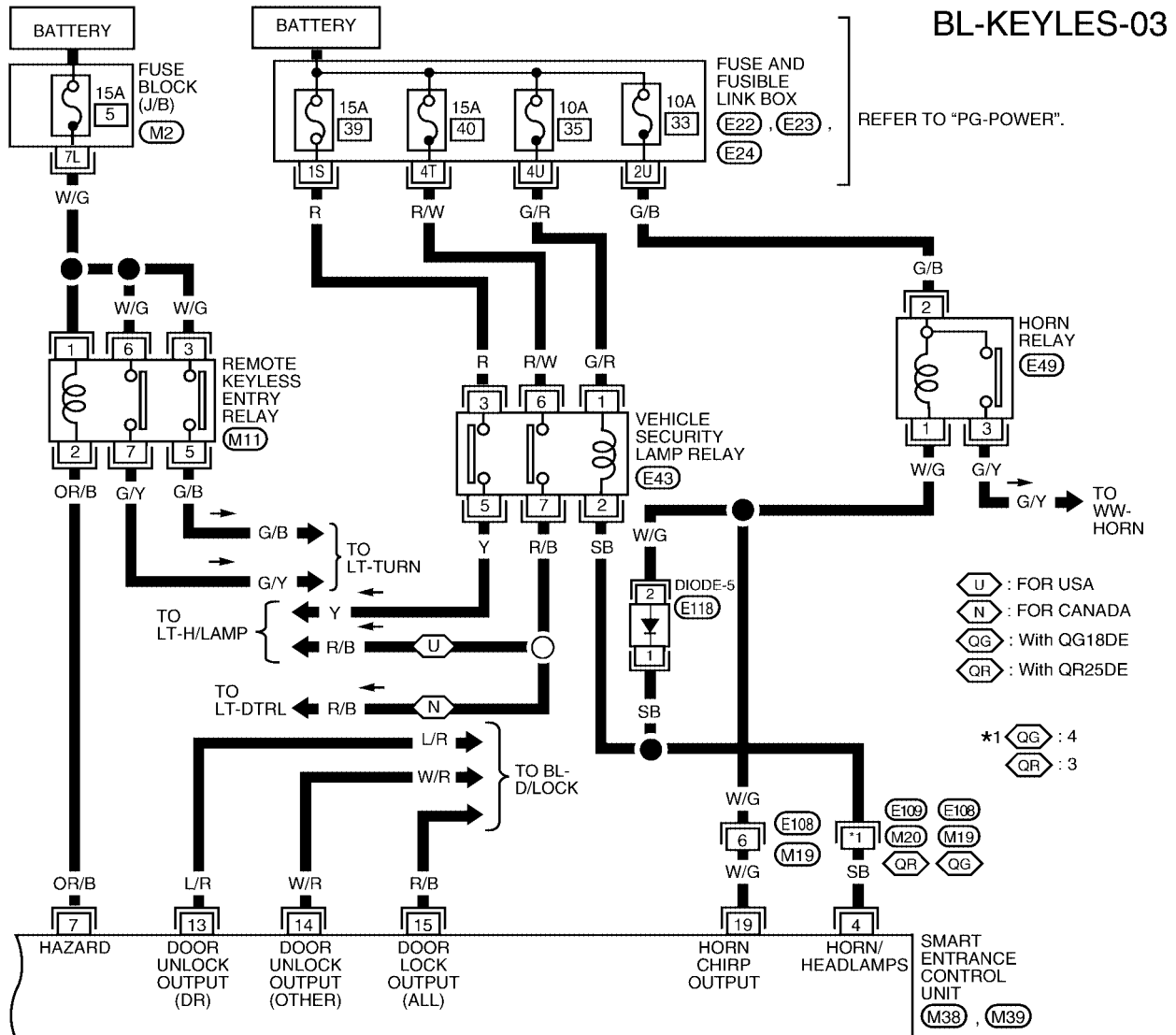

WIWA0072E

SMART ENTRANCE CONTROL UNIT TERMINALS AND REFERENCE VALUE MEASURED BETWEEN EACH TERMINAL AND GROUND

TERMINAL	WIRE COLOR	ITEM	CONDITION	DATA (DC)
4	SB	VEHICLE SECURITY HORN RELAY AND VEHICLE SECURITY LAMP RELAY	WHEN PANIC ALARM IS OPERATED USING REMOTE CONTROLLER OR WHEN ALARM IS ACTIVATED	12V TO 0V
7	OR/B	MULTI-REMOTE CONTROL RELAY	WHEN DOORS ARE LOCKED USING REMOTE CONTROLLER	12V TO 0V
19	W/G	HORN RELAY	WHEN DOORS ARE LOCKED USING REMOTE CONTROLLER WITH HORN CHIRP MODE	12V TO 0V

WEL104A

# REMOTE KEYLESS ENTRY SYSTEM

EIS00158

## CONSULT-II Inspection Procedure "MULTI REMOTE ENT"

1. Turn ignition switch "OFF".

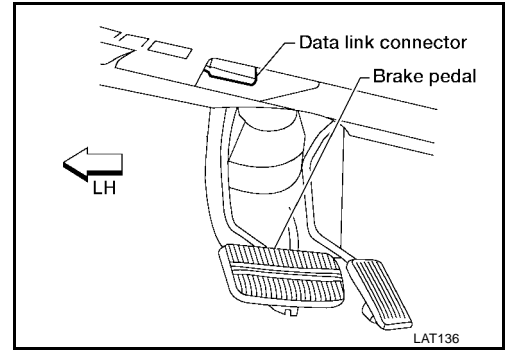

2. Connect "CONSULT-II" to the data link connector.

3. Turn ignition switch "ON".

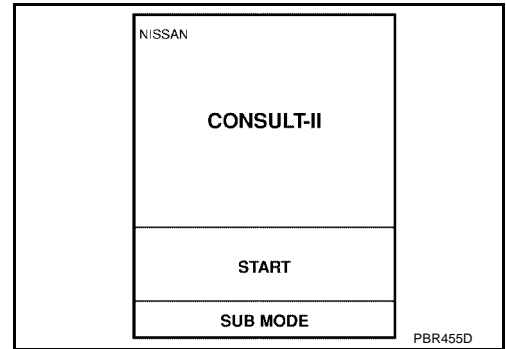

4. Touch "START".

5. Touch "SMART ENTRANCE".

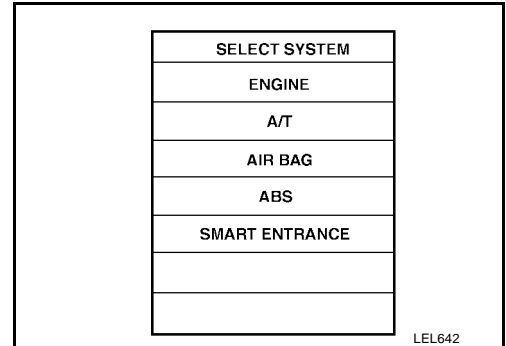

6. Touch "MULTI REMOTE ENT".

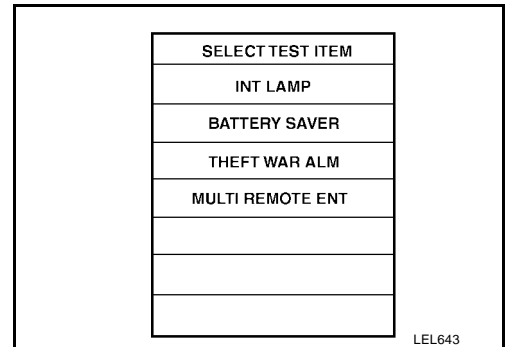

7. Select diagnosis mode.

# REMOTE KEYLESS ENTRY SYSTEM

“DATA MONITOR”, “ACTIVE TEST” and “WORK SUPPORT” are available.

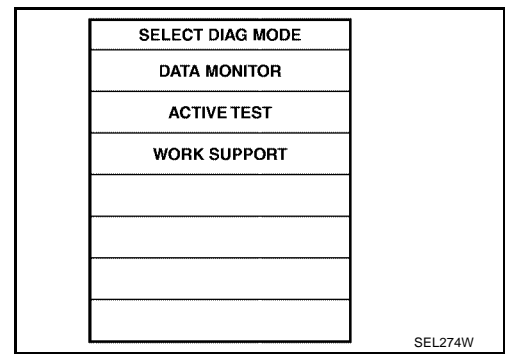

A  
B  
C  
D

## CONSULT-II Application Items “MULTI REMOTE ENT”

E/S00159

### Data Monitor

Monitored Item	Description
ACC ON SW	Indicates [ON/OFF] condition of ignition switch in ACC position.
KEY ON SW	Indicates [ON/OFF] condition of key switch.
DOOR SW-DR	Indicates [ON/OFF] condition of front door switch LH.
DOOR SW-ALL	Indicates [ON/OFF] condition of door switch (All).
LOCK SW DR/AS	Indicates [ON/OFF] condition of lock signal from lock/unlock switch LH and RH.
UNLK SW DR/AS	Indicates [ON/OFF] condition of unlock signal from lock/unlock switch LH and RH.
KEY CYL LK SW	Indicates [ON/OFF] condition of lock signal from key cylinder switch.
LK BUTTON/SIG	Indicates [ON/OFF] condition of lock signal from keyfob.
UN BUTTON/SIG	Indicates [ON/OFF] condition of unlock signal from keyfob.
TRUNK BTN/SIG	Indicates [ON/OFF] condition of trunk open signal from keyfob.
PANIC BTN	Indicates [ON/OFF] condition of panic signal from keyfob.
UN BUTTON ON	Indicates [ON/OFF] condition of second unlock signal from keyfob within 5 seconds after first unlock operation.
LK/UN BTN ON	Indicates [ON/OFF] condition of lock/unlock signal at the same time from keyfob.

E  
F  
G  
H  
BL

### Active Test

Test Item	Description
INT/IGN ILLUM	This test is able to check interior lamp operation. The interior lamp is turned on when “ON” on CONSULT-II screen is touched.
HAZARD	This test is able to check hazard reminder operation. The hazard lamps turn on when “ON” on CONSULT-II screen is touched.
ALARM	This test is able to check panic alarm operation. The alarm activates for 0.5 seconds after “ON” on CONSULT-II screen is touched.
MULTI REM HRN	This test is able to check horn reminder operation. The horn sounds for 0.02 seconds after “ON” on CONSULT-II screen is touched.
TRUNK OUTPUT	This test is able to check trunk lid opener actuator operation. The trunk is unlocked when “ON” on CONSULT-II screen is touched.

J  
K

### Work Support

Test Item	Description
REMO CONT ID CONFIR	It can be checked whether keyfob ID code is registered or not in this mode.
REMO CONT ID REGIST	Keyfob ID code can be registered.
REMO CONT ID ERASUR	Keyfob ID code can be erased.
HZRD REM SET	Hazard and horn reminder mode can be changed in this mode. The reminder mode will be changed when “MODE SET” on CONSULT-II screen is touched.

L  
M

# REMOTE KEYLESS ENTRY SYSTEM

EIS0015A

## Trouble Diagnoses SYMPTOM CHART

### NOTE:

- Always check keyfob battery before replacing keyfob.
- The panic alarm operation and trunk lid opener operation of remote keyless entry system do not activate with the ignition key inserted in the ignition key cylinder.
- Use Remote Keyless Entry Tester J-43241 (follow instructions on tester) to check operation of keyfob before replacing keyfob.

Symptom	Diagnoses/service procedure	Reference page (BL- )
All functions of remote keyless entry system do not operate.	1. Keyfob battery and function check Keyfob check (use Remote Keyless Entry Tester J-43241).	<a href="#">BL-46</a>
	2. Power supply and ground circuit for smart entrance control unit check	<a href="#">BL-47</a>
	3. Replace keyfob. Refer to ID Code Entry Procedure. NOTE: If the result of keyfob function check with CONSULT-II is OK, keyfob is not malfunctioning. Keyfob check (use Remote Keyless Entry Tester J-43241).	<a href="#">BL-60</a>
The new ID of keyfob cannot be entered.	1. Keyfob battery and function check Keyfob check (use Remote Keyless Entry Tester J-43241).	<a href="#">BL-46</a>
	2. Key switch (insert) check	<a href="#">BL-50</a>
	3. Door switch check	<a href="#">BL-49</a>
	4. Door lock/unlock switch LH check	<a href="#">BL-51</a>
	5. Power supply and ground circuit for smart entrance control unit check	<a href="#">BL-47</a>
	6. Replace keyfob. Refer to ID Code Entry Procedure. NOTE: If the result of keyfob function check with CONSULT-II is OK, keyfob is not malfunctioning. Keyfob check (use Remote Keyless Entry Tester J-43241).	<a href="#">BL-60</a>
Door lock or unlock does not function. [If the power door lock system does not operate manually, check power door lock system. Refer to <a href="#">BL-22</a> , "Trouble Diagnoses" .)	1. Keyfob battery and function check Keyfob check (use Remote Keyless Entry Tester J-43241).	<a href="#">BL-46</a>
	2. Replace keyfob. Refer to ID Code Entry Procedure. NOTE: If the result of keyfob function check with CONSULT-II is OK, keyfob is not malfunctioning. Keyfob check (use Remote Keyless Entry Tester J-43241).	<a href="#">BL-60</a>
Hazard and horn reminder does not activate properly when pressing lock or unlock button of keyfob.	1. Keyfob battery and function check Keyfob check (use Remote Keyless Entry Tester J-43241).	<a href="#">BL-46</a>
	2. Hazard reminder check	<a href="#">BL-56</a>
	3. Horn reminder check* *: Horn chirp can be activated or deactivated. First check the horn chirp setting. Refer to <a href="#">BL-35</a> , "Hazard and Horn Reminder" .	<a href="#">BL-58</a>
	4. Door switch check	<a href="#">BL-49</a>
	5. Replace keyfob. Refer to ID Code Entry Procedure. NOTE: If the result of keyfob function check with CONSULT-II is OK, keyfob is not malfunctioning. Keyfob check (use Remote Keyless Entry Tester J-43241).	<a href="#">BL-60</a>
Interior lamp illumination operations do not activate properly.	1. Interior lamp operation check	<a href="#">BL-59</a>
	2. Door switch check	<a href="#">BL-49</a>
	3. Front LH door unlock sensor check	<a href="#">BL-53</a>

# REMOTE KEYLESS ENTRY SYSTEM

Symptom	Diagnoses/service procedure	Reference page (BL- )
Panic alarm (horn and headlamp) does not activate when panic alarm button is continuously pressed. Keyfob check (use Remote Keyless Entry Tester J-43241).	1. Keyfob battery and function check	<a href="#">BL-46</a>
	2. Vehicle security operation check. Refer to <a href="#">BL-77, "PRELIMINARY CHECK"</a> .	<a href="#">BL-77</a>
	3. Key switch (insert) check	<a href="#">BL-50</a>
	4. Replace keyfob. Refer to ID Code Entry Procedure. NOTE: If the result of keyfob function check with CONSULT-II is OK, keyfob is not malfunctioning. Keyfob check (use Remote Keyless Entry Tester J-43241).	<a href="#">BL-60</a>
Trunk lid does not open when trunk opener button is continuously pressed.	1. Keyfob battery and function check	<a href="#">BL-46</a>
	2. Trunk lid opener actuator check	<a href="#">BL-55</a>
	3. Key switch (insert) check	<a href="#">BL-50</a>
	4. Replace keyfob. Refer to ID Code Entry Procedure. NOTE: If the result of keyfob function check with CONSULT-II is OK, keyfob is not malfunctioning. Keyfob check (use Remote Keyless Entry Tester J-43241).	<a href="#">BL-60</a>

A  
B  
C  
D  
E  
F  
G  
H  
J  
K  
L  
M

BL

# REMOTE KEYLESS ENTRY SYSTEM

## KEYFOB BATTERY AND FUNCTION CHECK

### 1. CHECK KEYFOB BATTERY

Remove battery (refer to [BL-63, "Keyfob Battery Replacement"](#) ) and measure voltage across battery positive and negative terminals, (+) and (-).

**Voltage [V] : 2.5 - 3.0**

**NOTE:**

Keyfob does not function if battery is not set correctly.

**OK or NG**

- OK >> GO TO 2.
- NG >> Replace battery.

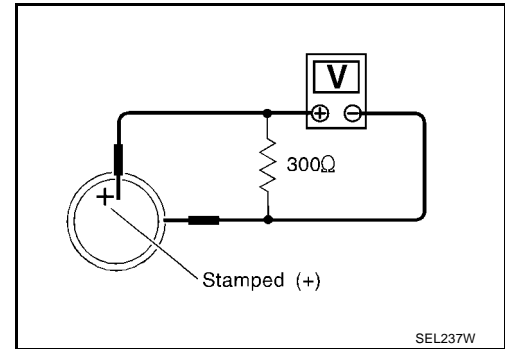

### 2. CHECK KEYFOB FUNCTION

**With CONSULT-II**

Check keyfob function ("LK BUTTON/SIG", "UN BUTTON/SIG", "TRUNK BTN/SIG", "PANIC BTN", "UN BUTTON ON" and "LK/UN BTN ON") in "DATA MONITOR" mode with CONSULT-II. When pushing each button of keyfob, the corresponding monitor item should be turned as follows.

Condition	Monitor item	
Pushing LOCK	LK BUTTON/SIG	ON
Pushing UNLOCK	UN BUTTON/SIG	ON
Pushing TRUNK	TRUNK BTN/SIG	ON
Pushing PANIC	PANIC BTN/SIG	ON
Pushing UNLOCK within 5 seconds after pushing UNLOCK	UN BUTTON ON	ON
Pushing LOCK and UNLOCK at the same time	LK/UN BTN ON	ON

DATA MONITOR	
MONITOR	
LK BUTTON/SIG	ON
UN BUTTON/SIG	ON
TRUNK BTN/SIG	ON
PANIC BTN	ON
UN BUTTON ON	ON
LK/UN BTN ON	ON

WIIA0008E

**OK or NG**

- OK >> Keyfob is OK. Further inspection is necessary. Refer to [BL-44, "SYMPTOM CHART"](#) .
- NG >> Replace keyfob. Refer to [BL-60, "ID Code Entry Procedure"](#) .

# REMOTE KEYLESS ENTRY SYSTEM

## POWER SUPPLY AND GROUND CIRCUIT CHECK

### 1. CHECK MAIN POWER SUPPLY CIRCUIT FOR SMART ENTRANCE CONTROL UNIT

1. Disconnect smart entrance control unit harness connector.
2. Check voltage between smart entrance control unit harness connector terminals 10, 11 and ground.

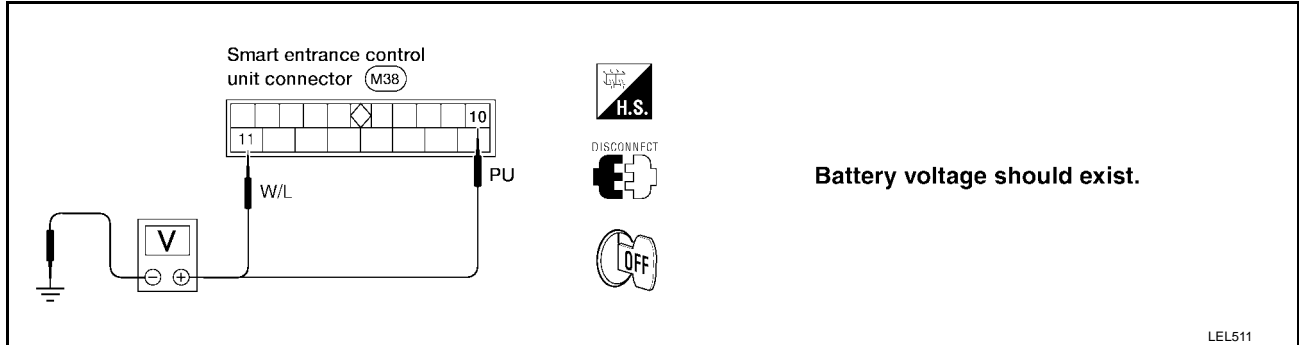

Refer to [BL-39, "FIG. 1"](#) .

#### OK or NG

OK >> GO TO 2.

NG >> Check the following.

- 30A fusible link (letter **d** , located in fuse and fusible link box)
- 10A fuse (No. 37, located in fuse and fusible link box)
- M6 circuit breaker
- Harness for open or short between smart entrance control unit and fuse

### 2. CHECK IGNITION SWITCH “ACC” CIRCUIT

1. Disconnect smart entrance control unit harness connector.
2. Check voltage between smart entrance control unit harness connector terminal 21 and ground while ignition switch is “ACC”.

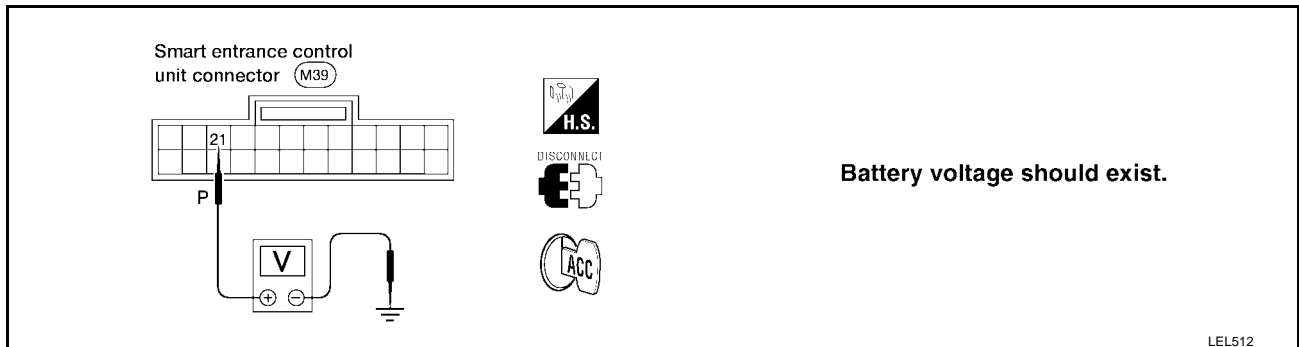

Refer to [BL-39, "FIG. 1"](#) .

#### OK or NG

OK >> GO TO 3.

NG >> Check the following.

- 10A fuse [No. 1, located in fuse block (J/B)]
- Harness for open or short between smart entrance control unit and fuse

# REMOTE KEYLESS ENTRY SYSTEM

## 3. CHECK GROUND CIRCUIT FOR SMART ENTRANCE CONTROL UNIT

Check continuity between smart entrance control unit harness connector terminal 16 and ground.

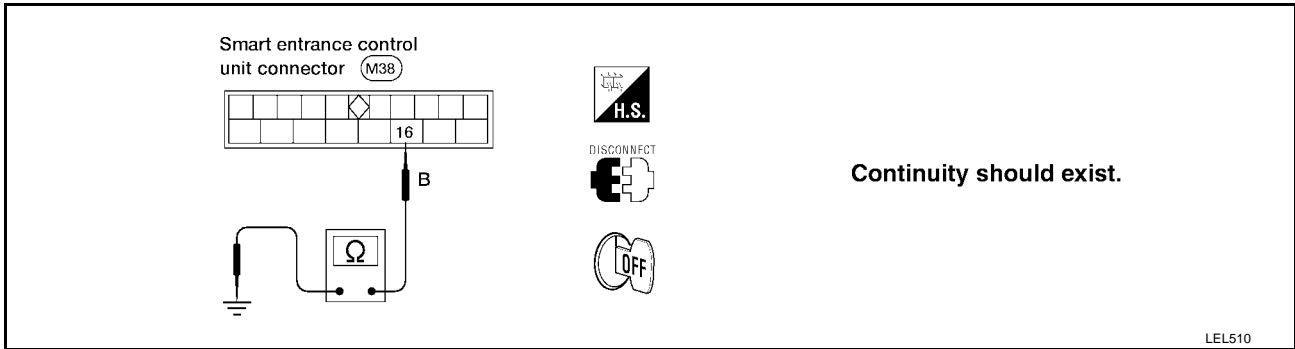

Refer to [BL-39, "FIG. 1"](#) .

OK or NG

- OK >> Power supply and ground circuits are OK.
- NG >> Check ground harness.



# REMOTE KEYLESS ENTRY SYSTEM

## DOOR SWITCH CHECK

### 1. CHECK DOOR SWITCH INPUT SIGNAL

#### With CONSULT-II

Check door switches ("DOOR SW-ALL") in "DATA MONITOR" mode with CONSULT-II.

DATA MONITOR	
MONITOR	
DOOR SW-ALL	OFF

When any doors are open:  
**DOOR SW-ALL ON**

When all doors are closed:  
**DOOR SW-ALL OFF**

SEL323W

#### Without CONSULT-II

Check voltage between smart entrance control unit harness connector terminals 28 or 29 and ground.

Smart entrance control unit connector (M39)

H.S.

CONNECT

OFF

	Terminals		Condition	Voltage [V]
	(+)	(-)		
Front door switch LH	29	Ground	Open	0
			Closed	Approx. 5
Other door switches	28	Ground	Open	0
			Closed	Approx. 5

WEL500

Refer to [BL-39, "FIG. 1"](#).

OK or NG

- OK >> Door switch is OK.
- NG >> GO TO 2.

### 2. CHECK DOOR SWITCH

1. Disconnect door switch harness connector.
2. Check continuity between door switch terminals.

Front door switch LH connector (B23)

Front door switch RH connector (B17)

DISCONNECT

Rear door switch connector

LH: (B26)

RH: (B32)

	Terminals	Condition	Continuity
Front door switch LH	2 - 3	Closed	No
		Open	Yes
Front door switch RH	1 - Ground	Closed	No
		Open	Yes
Rear door switches	(+) - Ground	Closed	No
		Open	Yes

WEL491

OK or NG

- OK >> Check the following.
  - Door switch ground circuit or door switch ground condition
  - Harness for open or short between smart entrance control unit and door switch
- NG >> Replace door switch.

# REMOTE KEYLESS ENTRY SYSTEM

## KEY SWITCH (INSERT) CHECK

### 1. CHECK KEY SWITCH INPUT SIGNAL

#### ④ With CONSULT-II

Check key switch ("KEY ON SW") in "DATA MONITOR" mode with CONSULT-II.

DATA MONITOR	
MONITOR	
KEY ON SW	ON

When key is inserted to ignition key cylinder:  
**KEY ON SW ON**

When key is removed from ignition key cylinder:  
**KEY ON SW OFF**

SEL315W

#### ⊗ Without CONSULT-II

Check voltage between control unit terminal 32 and ground.

Smart entrance control unit connector (M39)

L/W

V

H.S. CONNECT

CONNECT

Condition of key switch: Key is inserted.  
Approx. 12

Condition of key switch: Key is removed.  
0

LEL454

Refer to [BL-39, "FIG. 1"](#).

OK or NG

- OK >> Key switch is OK.
- NG >> GO TO 2.

### 2. CHECK KEY SWITCH

Check continuity between key switch terminals 1 and 2.

Key switch connector (E113)

T.S.

DISCONNECT

Continuity:

Condition of key switch: Key is inserted.  
Yes

Condition of key switch: Key is removed.  
No

LEL449

OK or NG

- OK >> Check the following.
  - 10A fuse [No. 12, located in fuse block (J/B)]
  - Harness for open or short between key switch and fuse
  - Harness for open or short between smart entrance control unit and key switch
- NG >> Replace key switch.

# REMOTE KEYLESS ENTRY SYSTEM

## DOOR LOCK/UNLOCK SWITCH LH CHECK

### 1. CHECK DOOR LOCK/UNLOCK SWITCH INPUT SIGNAL

#### With CONSULT-II

Check door lock/unlock switch ("LOCK SW DR/AS"/"UNLK SW DR/AS") in "DATA MONITOR" mode with CONSULT-II.

DATA MONITOR	
MONITOR	
LOCK SW DR/AS	OFF
UNLK SW DR/AS	OFF

When lock/unlock switch is turned to LOCK:  
**LOCK SW DR/AS ON**

When lock/unlock switch is turned to UNLOCK:  
**UNLK SW DR/AS ON**

SEL341W

#### Without CONSULT-II

1. Disconnect smart entrance control unit harness connector.
2. Check continuity between smart entrance control unit harness connector terminal 23 or 35 and ground.

Smart entrance control unit connector (M39)

**H.S.**

DISCONNECT

OFF

Terminals	Door lock/unlock switch (LH or RH) condition	Continuity
23 - Ground	Lock	Yes
	N and Unlock	No
35 - Ground	Unlock	Yes
	N and Lock	No

WEL501

Refer to [BL-40, "FIG. 2"](#) .

#### OK or NG

- OK    >> Door lock/unlock switch is OK.  
 NG    >> GO TO 2.

# REMOTE KEYLESS ENTRY SYSTEM

## 2. CHECK DOOR LOCK/UNLOCK SWITCH

1. Disconnect door lock/unlock switch harness connector.
2. Check continuity between door lock/unlock switch LH terminals.

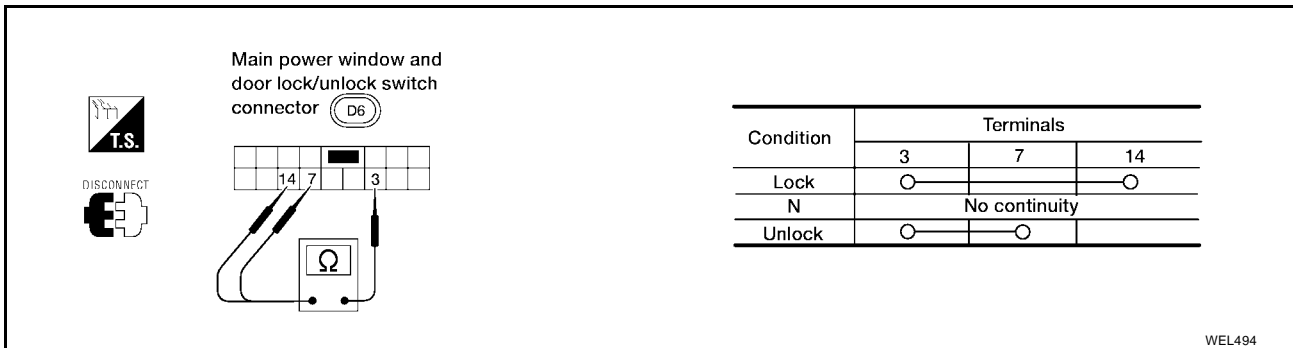

### OK or NG

OK >> Check the following.

- Ground circuit for door lock/unlock switch
- Harness for open or short between door lock/unlock switch and smart entrance control unit connector

NG >> Replace door lock/unlock switch.

# REMOTE KEYLESS ENTRY SYSTEM

## FRONT LH DOOR UNLOCK SENSOR CHECK

### 1. CHECK FRONT LH DOOR UNLOCK SENSOR INPUT SIGNAL

#### With CONSULT-II

1. Select "DATA MONITOR" mode in "INT LAMP" with CONSULT-II.
2. Check front LH door unlock sensor ("LOCK SIG DR") in "DATA MONITOR" mode.

DATA MONITOR	
MONITOR	MONITOR
LOCK SIG DR	OFF

When front LH door is locked:  
**LOCK SIG DR OFF**

When front LH door is unlocked:  
**LOCK SIG DR ON**

SEL344W

#### Without CONSULT-II

Check voltage between smart entrance control unit harness connector terminal 36 and ground.

Smart entrance control unit connector (M39)

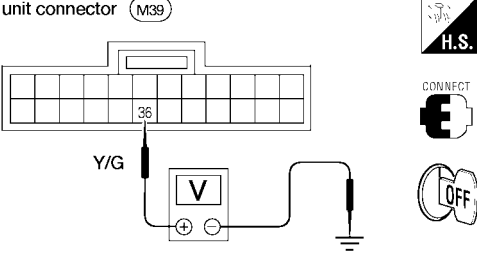

	Terminals		Condition	Voltage [V]
	(+)	(-)		
Front LH door	36	Ground	Locked	Approx. 5
			Unlocked	0

LEL452

Refer to [BL-40, "FIG. 2"](#) .

#### OK or NG

- OK    >> Door unlock sensor is OK.  
 NG    >> GO TO 2.

# REMOTE KEYLESS ENTRY SYSTEM

## 2. CHECK FRONT LH DOOR UNLOCK SENSOR

1. Disconnect front LH door unlock sensor harness connector.
2. Check continuity between door unlock sensor terminals.

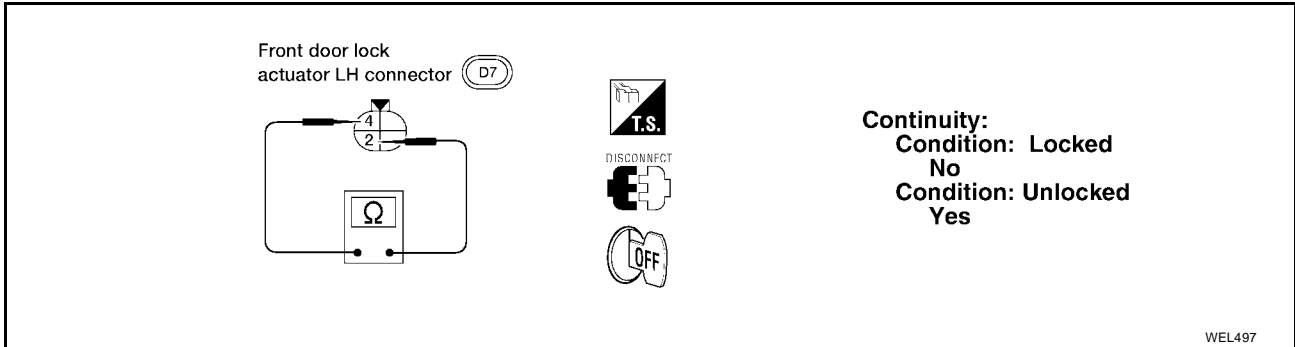

### OK or NG

OK >> Check the following.

- Door unlock sensor ground circuit
- Harness for open or short between smart entrance control unit and door unlock sensor

NG >> Replace door unlock sensor.

# REMOTE KEYLESS ENTRY SYSTEM

## TRUNK LID OPENER ACTUATOR CHECK

### 1. CHECK TRUNK LID OPENER

Check trunk lid opener operation with trunk lid opener switch.  
NOTE: First check trunk lid opener cancel lever position.

Does trunk lid open?

Yes >> GO TO 2.

No >> Check trunk lid opener actuator and the circuit.

### 2. CHECK TRUNK LID OPENER ACTUATOR OPERATION

 With CONSULT-II

1. Select "ACTIVE TEST" in "MULTI REMOTE ENT" with CONSULT-II.
2. Select "TRUNK OUTPUT" and touch "ON".

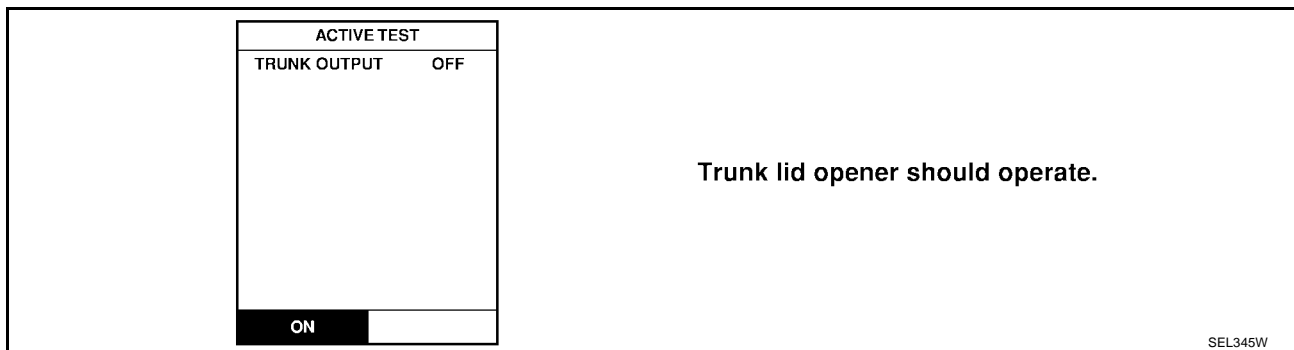

**NOTE: If CONSULT-II is not available, skip this procedure and go to the next step.**

OK or NG

OK >> Trunk lid opener actuator circuit is OK.

NG >> GO TO 3.

### 3. CHECK TRUNK LID OPENER ACTUATOR CIRCUIT

1. Disconnect smart entrance control unit harness connector.
2. Apply ground to smart entrance control unit harness connector terminal 12.

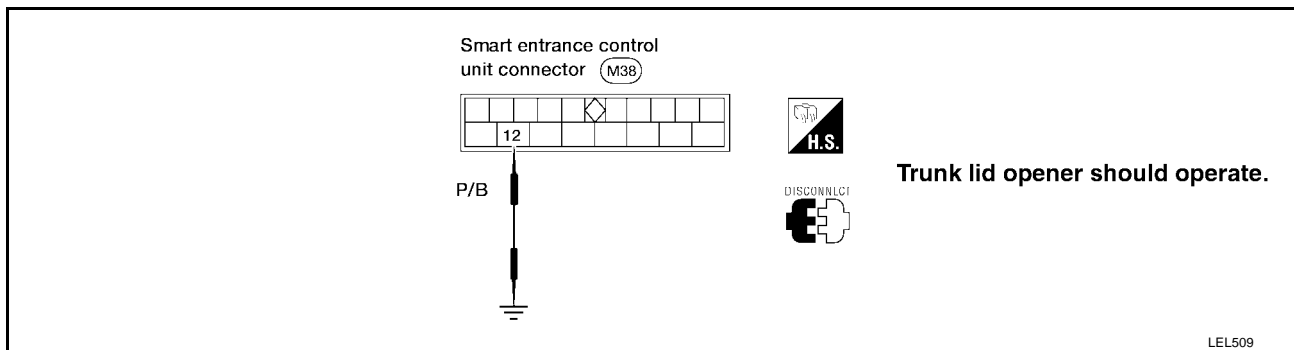

Refer to [BL-39, "FIG. 1"](#) .

Does trunk lid open?

Yes >> Replace smart entrance control unit.

No >> Check harness for open or short between smart entrance control unit and trunk lid opener actuator.

# REMOTE KEYLESS ENTRY SYSTEM

## HAZARD REMINDER CHECK

### 1. CHECK HAZARD INDICATOR

Check if hazard indicator flashes with hazard switch.

Does hazard indicator operate?

- Yes >> GO TO 2.
- No >> Check hazard indicator circuit.

### 2. CHECK HAZARD REMINDER OPERATION

Ⓟ With CONSULT-II

1. Select "ACTIVE TEST" in "MULTI REMOTE ENT" with CONSULT-II.
2. Select "HAZARD" and touch "ON".

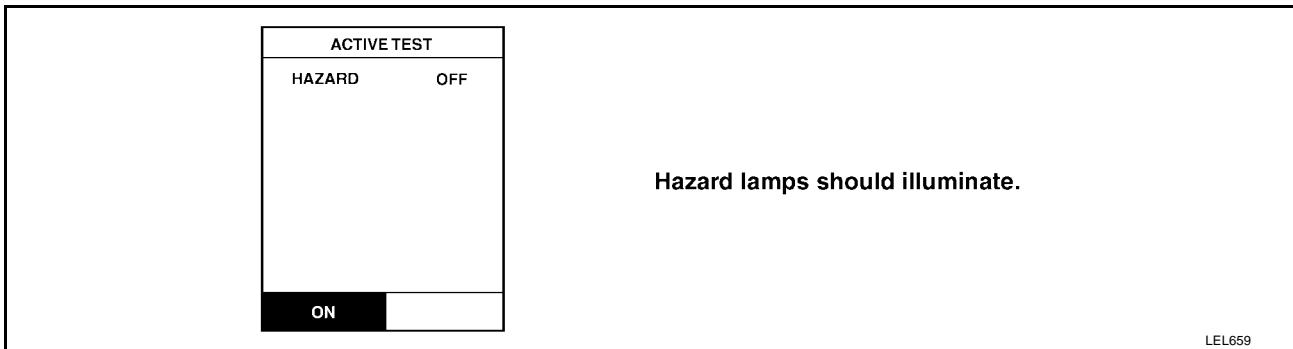

**NOTE:** If CONSULT-II is not available, skip this procedure and go to the next step.

OK or NG

- OK >> Hazard reminder operation is OK.
- NG >> GO TO 3.

### 3. CHECK HAZARD REMINDER OPERATION

1. Disconnect smart entrance control unit harness connector.
2. Apply ground to smart entrance control unit harness connector terminal 7.

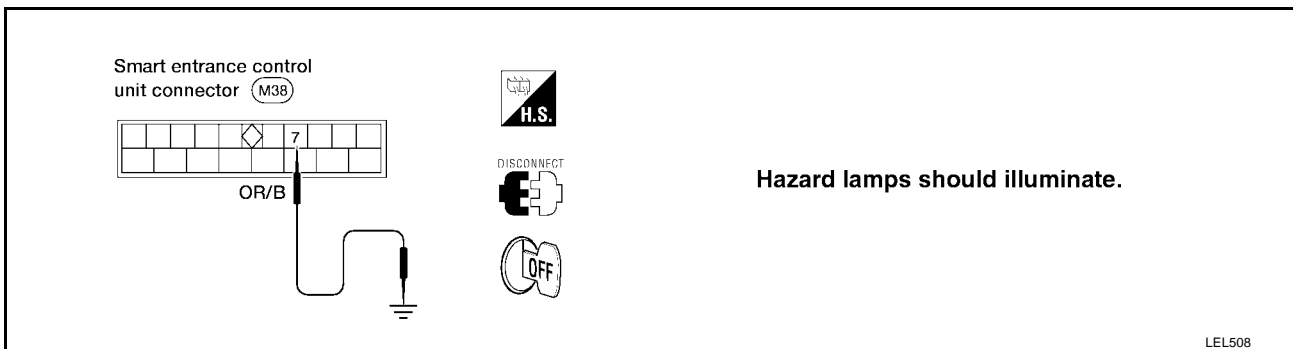

Refer to [BL-41, "FIG. 3"](#).

OK or NG

- OK >> Replace smart entrance control unit.
- NG >> GO TO 4.

### 4. CHECK REMOTE KEYLESS ENTRY RELAY

Check remote keyless entry relay.

OK or NG

- OK >> GO TO 5.
- NG >> Replace remote keyless entry relay.



# REMOTE KEYLESS ENTRY SYSTEM

## 5. CHECK POWER SUPPLY FOR REMOTE KEYLESS ENTRY RELAY

1. Disconnect remote keyless entry relay harness connector.
2. Check voltage between remote keyless entry relay harness connector M11 terminal 1 (W/G) and ground.

**Battery voltage should exist.**

OK or NG

OK >> GO TO 6.

NG >> Check the following.

- 15A fuse [No. 5, located in fuse block (J/B)]
- Harness for open or short between remote keyless entry relay and fuse

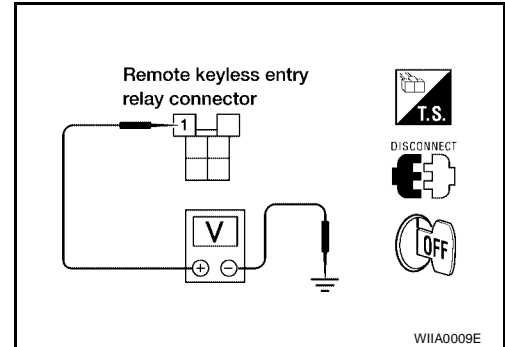

## 6. CHECK REMOTE KEYLESS ENTRY RELAY CIRCUIT

1. Disconnect remote keyless entry relay harness connector.
2. Check voltage between remote keyless entry relay harness connector M11 terminals 3 (W/G) and 5 (G/B).
3. Check voltage between remote keyless entry relay harness connector M11 terminals 6 (W/G) and 7 (G/Y).

**Battery voltage should exist.**

OK or NG

OK >> Check harness for open or short between smart entrance control unit and remote keyless entry relay.

NG >> Check the following.

- Harness for open or short between remote keyless entry relay and fuse
- Harness for open or short between remote keyless entry relay and turn signal lamps

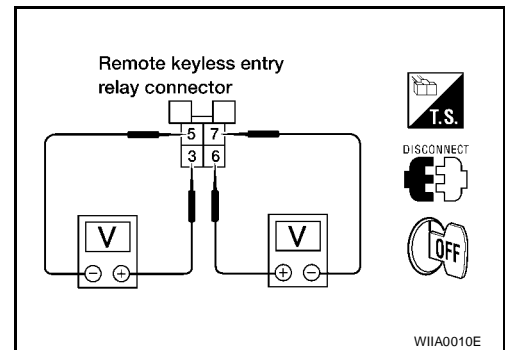

# REMOTE KEYLESS ENTRY SYSTEM

## HORN REMINDER CHECK

### 1. CHECK HORN

Check if horn sounds with horn switch.

Does horn operate?

Yes >> GO TO 2.

No >> Check horn circuit.

### 2. CHECK HORN REMINDER OPERATION

Ⓟ With CONSULT-II

1. Select "ACTIVE TEST" in "MULTI REMOTE ENT" with CONSULT-II.

2. Select "MULTI REM HRN" and touch "ON".

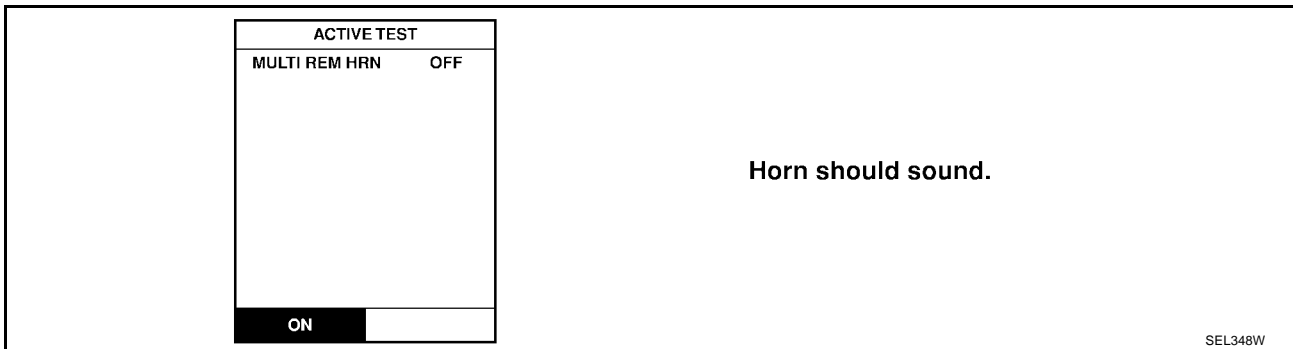

**NOTE:** If CONSULT-II is not available, skip this procedure and go to the next step.

OK or NG

OK >> Horn reminder operation is OK.

NG >> GO TO 3.

### 3. CHECK HORN REMINDER OPERATION

1. Disconnect smart entrance control unit harness connector.

2. Apply ground to smart entrance control unit harness connector terminal 19.

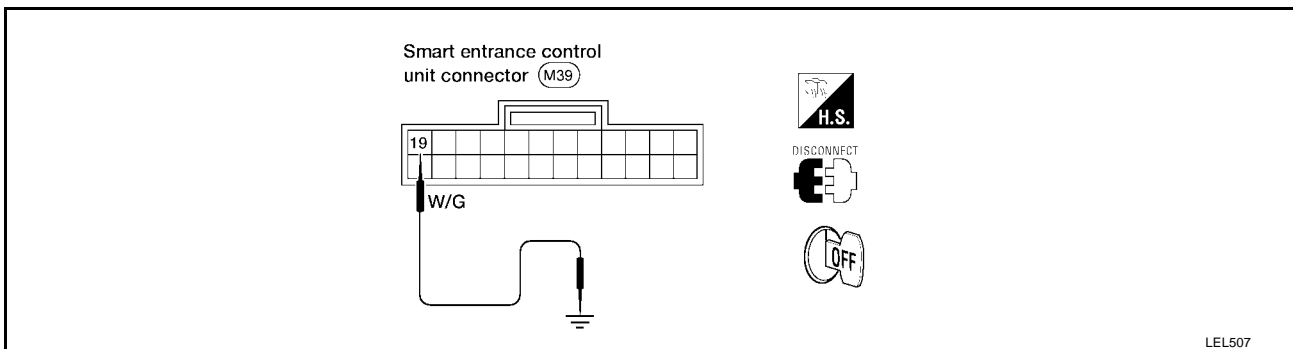

Refer to [BL-41, "FIG. 3"](#) .

Does horn sound?

Yes >> Replace smart entrance control unit.

No >> Check harness for open or short between smart entrance control unit and horn relay.

# REMOTE KEYLESS ENTRY SYSTEM

## INTERIOR LAMP OPERATION CHECK

### 1. CHECK INTERIOR LAMP

Check if the interior lamp switch is in the "ON" position and the lamp illuminates.

Does interior lamp illuminate?

Yes >> GO TO 2.

No >> Check the following.

- Harness for open or short between smart entrance control unit and interior lamp
- Interior lamp

### 2. CHECK INTERIOR LAMP OPERATION

#### With CONSULT-II

1. Select "ACTIVE TEST" in "MULTI REMOTE ENT" with CONSULT-II.
2. Select "INT/IGN ILLUM" and touch "ON".

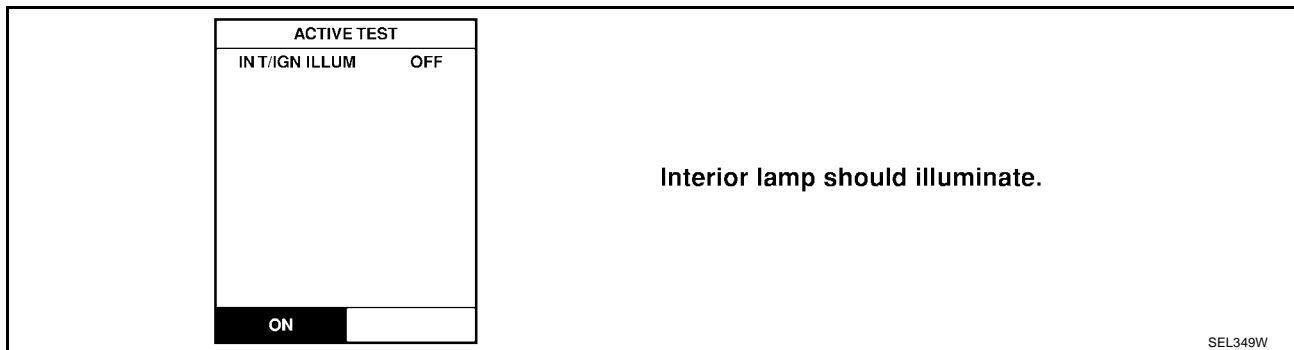

#### Without CONSULT-II

Push unlock button of keyfob with all doors closed, and check voltage between smart entrance control unit harness connector terminal 8 and ground.

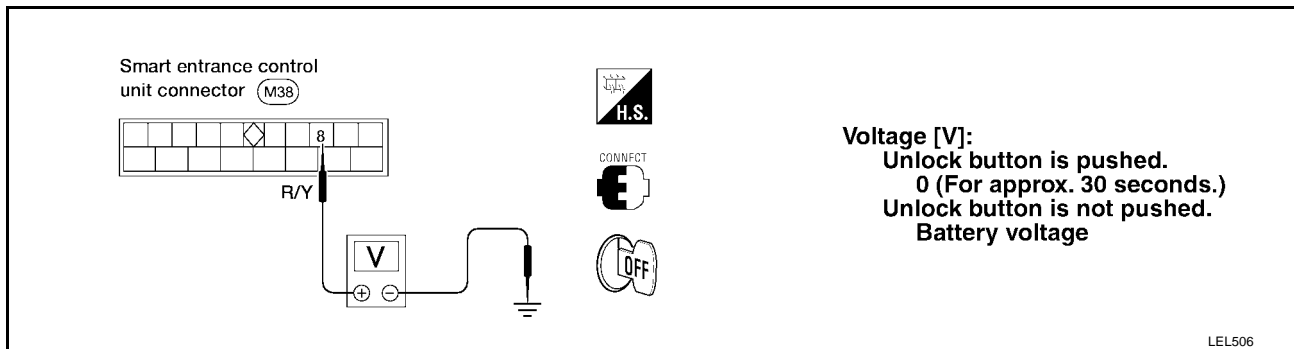

Refer to [BL-40, "FIG. 2"](#) .

OK or NG

OK >> System is OK.

NG >> Check harness open or short between smart entrance control unit and interior lamp.

# REMOTE KEYLESS ENTRY SYSTEM

EIS0015B

## ID Code Entry Procedure KEYFOB ID SET UP WITH CONSULT-II

### NOTE:

If a keyfob is lost, the ID code of the lost keyfob must be erased to prevent unauthorized use. When the ID code of a lost keyfob is not known, all keyfob ID codes should be erased. After all ID codes are erased, the ID codes of all remaining and/or new keyfobs must be re-registered.

1. Turn ignition switch "OFF".

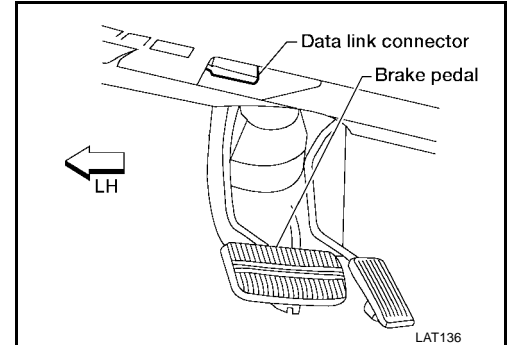

2. Connect "CONSULT-II" to the data link connector.

3. Turn ignition switch "ON".

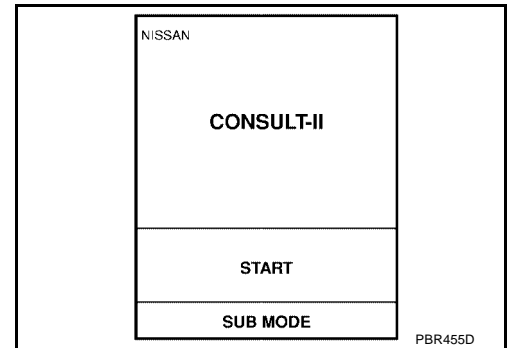

4. Touch "START".

5. Touch "SMART ENTRANCE".

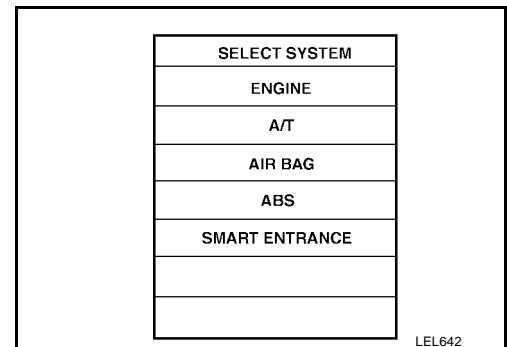

6. Touch "MULTI REMOTE ENT".

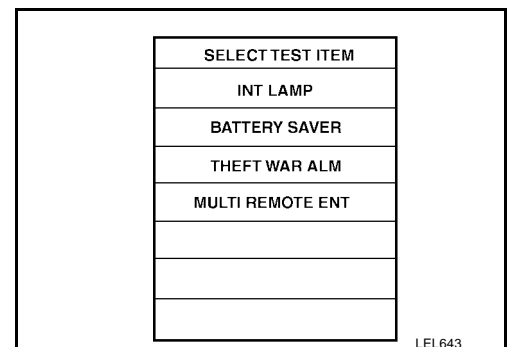

# REMOTE KEYLESS ENTRY SYSTEM

7. Touch "WORK SUPPORT".

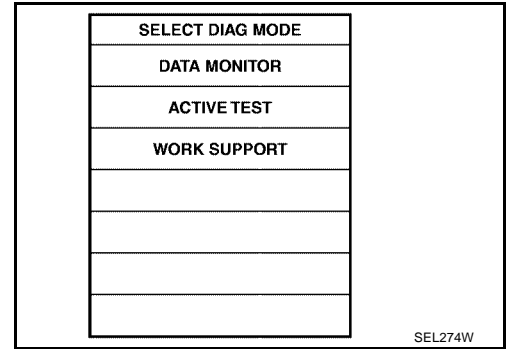

A  
B  
C  
D

8. The items are shown that can be set up.

- "REMO CONT ID CONFIR"  
Use this mode to confirm if a keyfob ID code is registered or not.
- "REMO CONT ID REGIST"  
Use this mode to register a keyfob ID code.

**NOTE:**

**Register the ID code when keyfob or smart entrance control unit is replaced, or when additional keyfob is required.**

- "REMO CONT ID ERASUR"  
Use this mode to erase a keyfob ID code.
- "HZRD REM SET"  
Use this mode to activate or deactivate the hazard and horn reminder.

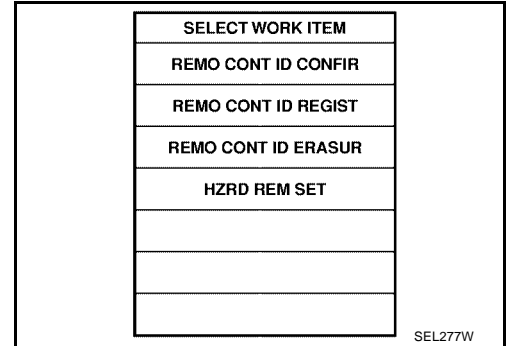

E  
F  
G  
H

BL

J  
K  
L  
M

# REMOTE KEYLESS ENTRY SYSTEM

## KEYFOB ID SET UP WITHOUT CONSULT-II

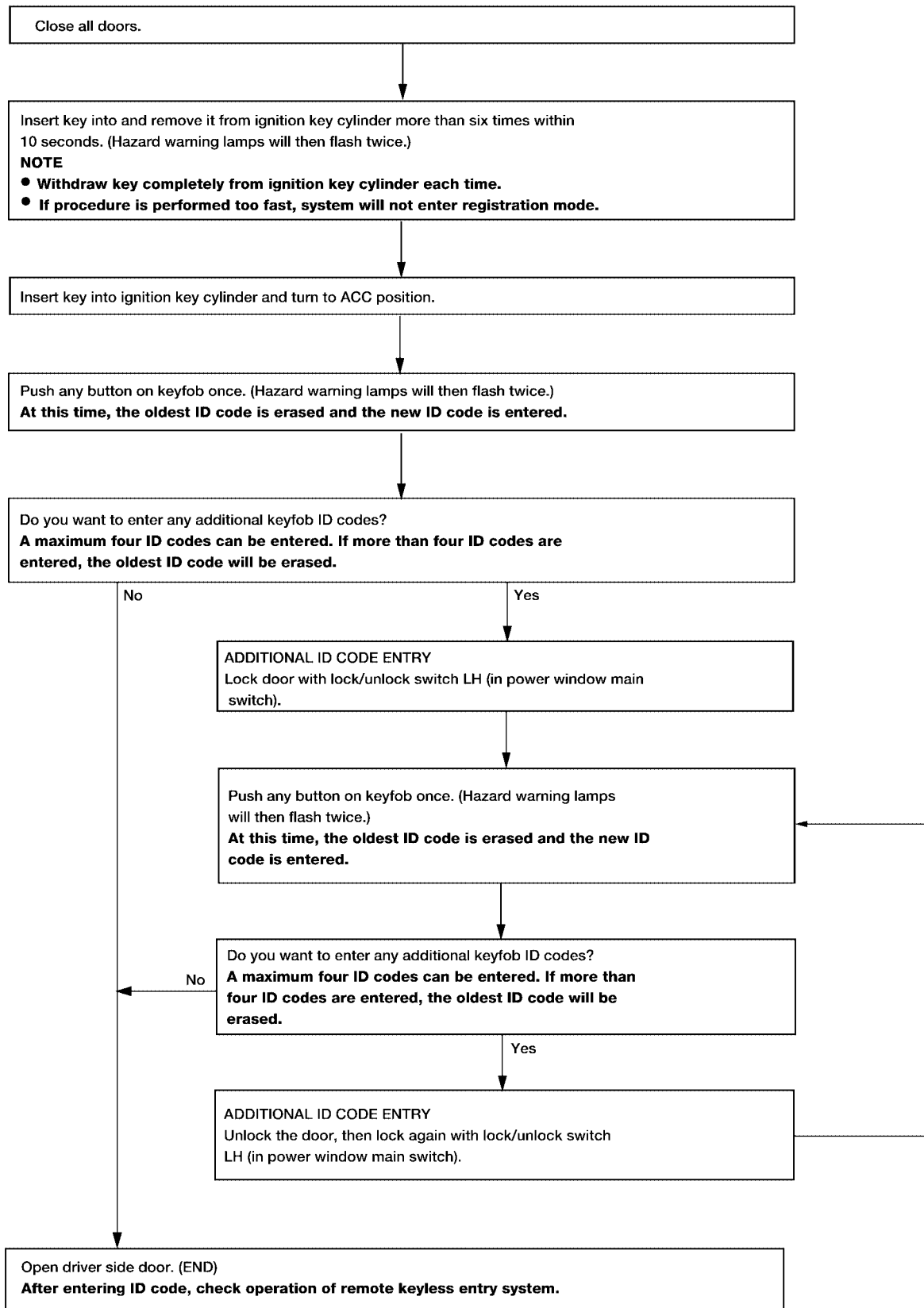

W11A0011E

# REMOTE KEYLESS ENTRY SYSTEM

## NOTE:

- If a keyfob is lost, the ID code of the lost keyfob must be erased to prevent unauthorized use. A specific ID code can be erased with CONSULT-II. However, when the ID code of a lost keyfob is not known, all keyfob ID codes should be erased. After all ID codes are erased, the ID codes of all remaining and/or new keyfobs must be re-registered.  
To erase all ID codes in memory, register one ID code (keyfob) four times. After all ID codes are erased, the ID codes of all remaining and/or new keyfobs must be re-registered.
- When registering an additional keyfob, the existing ID codes in memory may or may not be erased. If four ID codes are stored in memory, when an additional code is registered, only the oldest code is erased. If less than four ID codes are stored in memory, when an additional ID code is registered, the new ID code is added and no ID codes are erased.
- If you need to activate more than two additional new keyfobs, repeat the procedure "Additional ID code entry" for each new keyfob.
- Entry of maximum four ID codes is allowed. When more than four ID codes are entered, the oldest ID code will be erased.
- Even if same ID code that is already in the memory is input, the same ID code can be entered. The code is counted as an additional code.

## Keyfob Battery Replacement

EIS0015C

### NOTE:

- Be careful not to touch the circuit board or the battery terminal.
- The keyfob is water-resistant. However, if it does get wet, immediately wipe it dry.

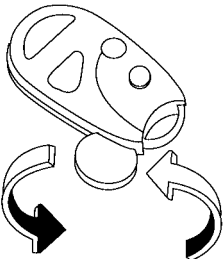
- 

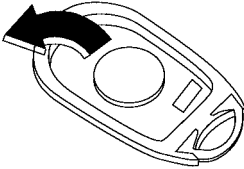
1. Open the lid using a coin.
- 

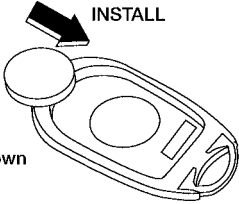
2. Remove the battery.
- 

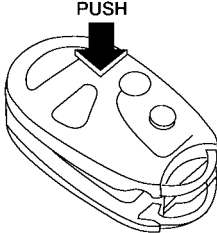
3. Insert the new battery.  
"++" side facing down
- 

4. Close the lid securely.  
Push the keyfob button two or three times to check its operation.

WHIA0012E

# VEHICLE SECURITY (THEFT WARNING) SYSTEM

## VEHICLE SECURITY (THEFT WARNING) SYSTEM

PFP:00100

### Component Parts and Harness Connector Location

EIS0015D

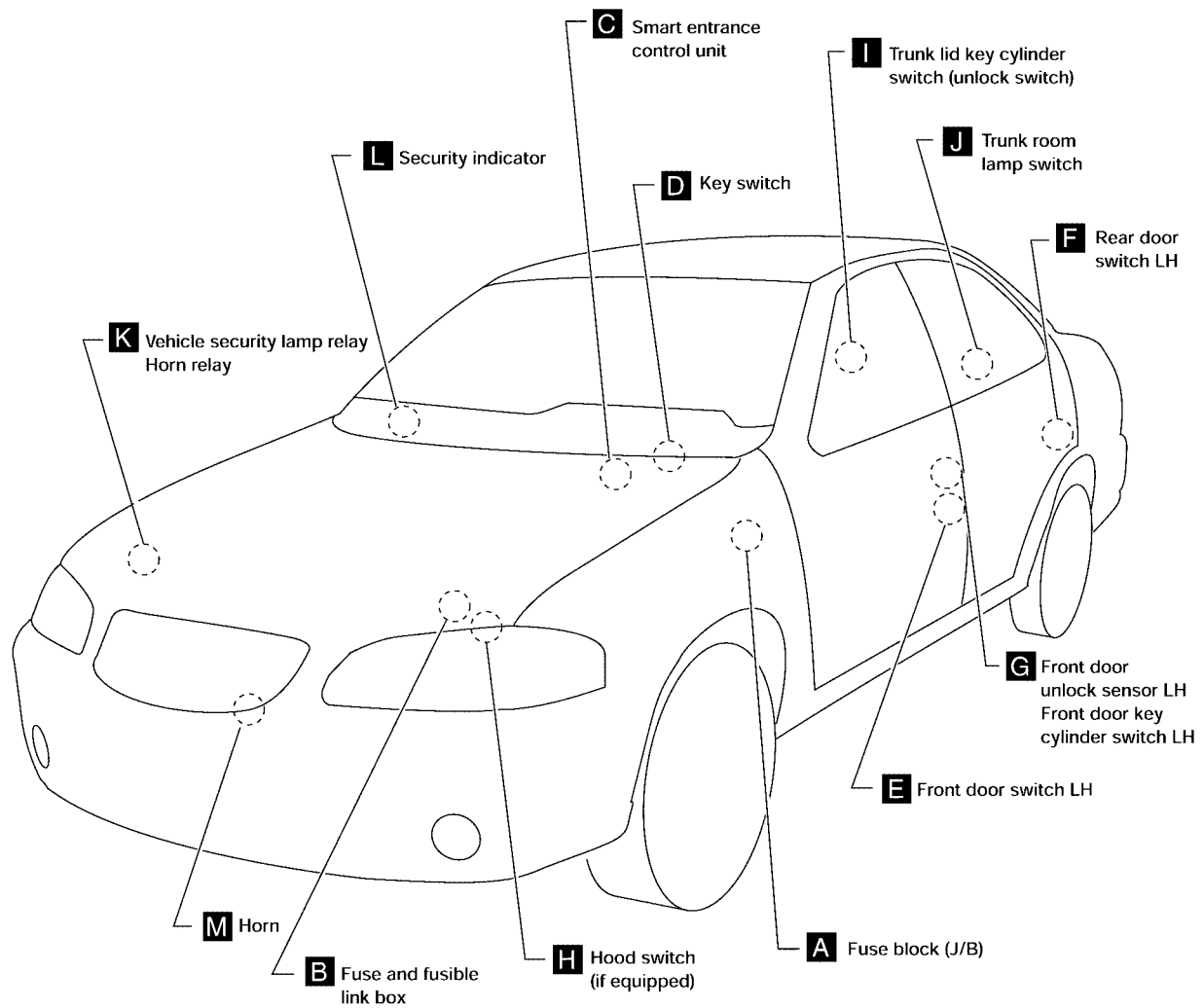

LIA0594E



# VEHICLE SECURITY (THEFT WARNING) SYSTEM

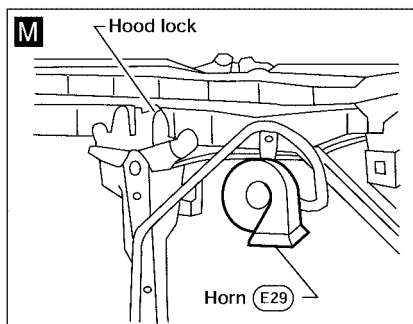
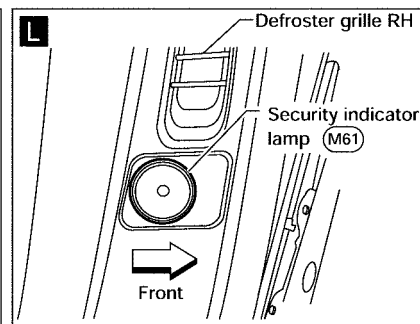
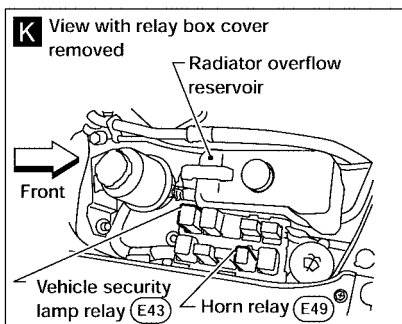
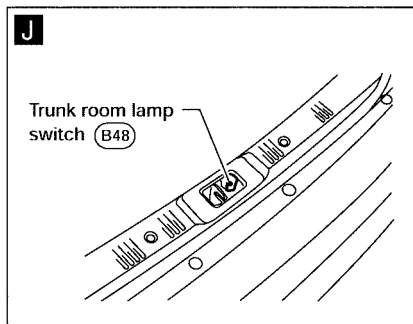
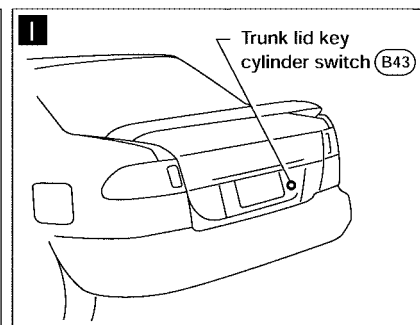
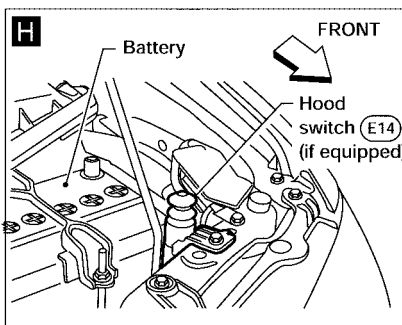
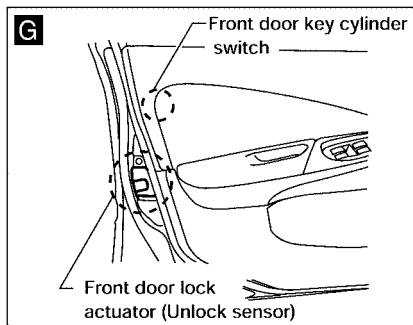
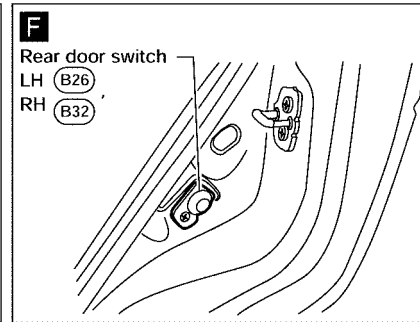
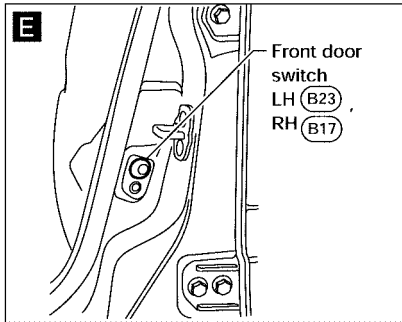
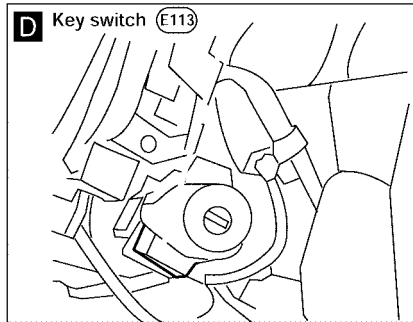
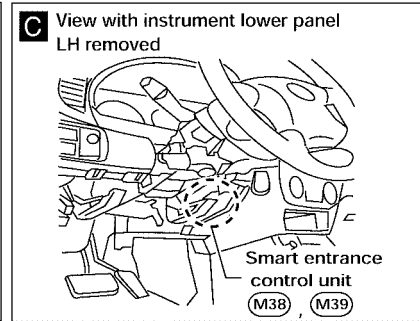
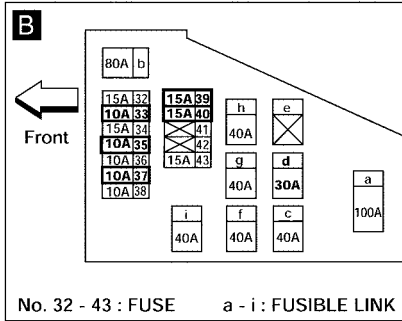
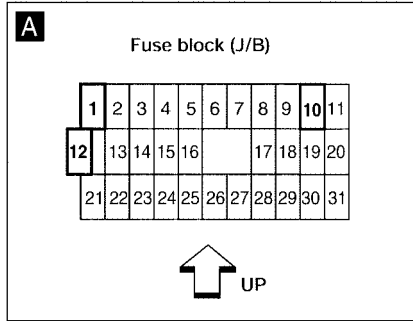

A  
B  
C  
D  
E  
F  
G  
H  
J  
K  
L  
M

BL

L1IA0595E

# VEHICLE SECURITY (THEFT WARNING) SYSTEM

EIS0015E

## System Description DESCRIPTION

### 1. Operation Flow

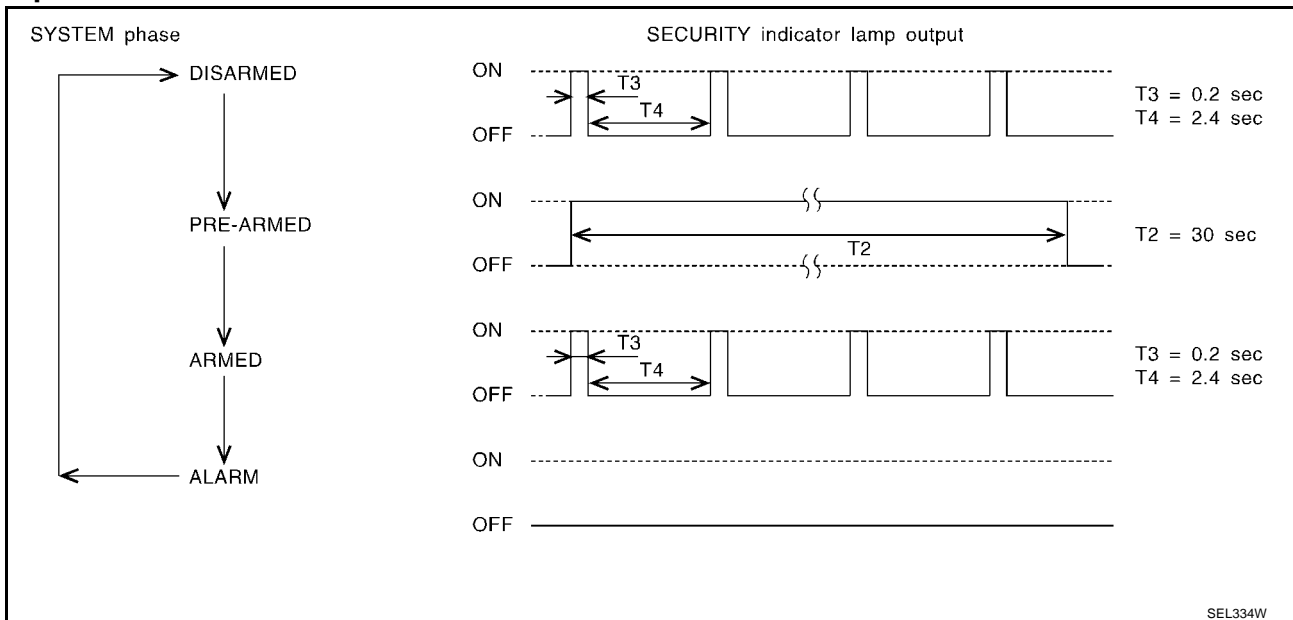

### 2. Setting The Vehicle Security System

#### Initial condition

1. Ignition switch is in OFF position.

#### Disarmed phase

When the vehicle security system is in the disarmed phase, the security indicator lamp blinks every 2.6 seconds.

#### Pre-armed phase and armed phase

When the following operation 1 or 2 is performed, the vehicle security system turns into the “pre-armed” phase. (The security indicator lamp illuminates.)

1. Smart entrance control unit receives LOCK signal from key cylinder switch or keyfob after hood, trunk lid and all doors are closed.
2. Hood (if equipped with hood switch), trunk lid and all doors are closed after front doors are locked by key, lock/unlock switch or keyfob.

After about 30 seconds, the system automatically shifts into the “armed” phase (the system is set). (The security indicator lamp blinks every 2.6 seconds.)

### 3. Canceling The Set Vehicle Security System

When the following 1 or 2 operation is performed, the armed phase is canceled.

1. Unlock the doors with the key or keyfob.
2. Open the trunk lid with the key or keyfob.

### 4. Activating The Alarm Operation of The Vehicle Security System

Make sure the system is in the armed phase. (The security indicator lamp blinks every 2.6 seconds.)

When the following operation 1 or 2 is performed, the system sounds the horns and flashes the headlamps for about 50 seconds.

1. Engine hood (if equipped with hood switch), trunk lid or any door is opened during armed phase.
2. Disconnecting and connecting the battery connector before canceling armed phase.

### POWER SUPPLY AND GROUND

Power is supplied at all times:

- through 10A fuse [No. 12, located in the fuse block (J/B)]
- to security indicator lamp terminal 1 and
- to key switch terminal 2.

Power is supplied at all times:

# VEHICLE SECURITY (THEFT WARNING) SYSTEM

- through 10A fuse (No. 37, located in the fuse and fusible link box)
- to smart entrance control unit terminal 10.

With the ignition switch in the ON or START position, power is supplied:

- through 10A fuse [No. 10, located in the fuse block (J/B)]
- to smart entrance control unit terminal 33.

With the ignition switch in the ACC or ON position, power is supplied:

- through 10A fuse [No. 1, located in the fuse block (J/B)]
- to smart entrance control unit terminal 21.

Ground is supplied:

- to smart entrance control unit terminal 16
- through body grounds M28 and M54.

## INITIAL CONDITION TO ACTIVATE THE SYSTEM

The operation of the vehicle security system is controlled by the doors, hood (if equipped with hood switch) and trunk lid.

### Pattern A

To activate the vehicle security system, the smart entrance control unit must receive signals indicating the doors, hood (if equipped with hood switch) and trunk lid are closed.

When a door is open, smart entrance control unit terminal 28 or 29 receives a ground signal from each door switch.

On vehicles equipped with hood switch, when the hood is open, smart entrance control unit terminal 27 receives a ground signal:

- from terminal + of the hood switch
- to terminal - of the hood switch
- through body grounds E7 and E37.

When the trunk lid is open, smart entrance control unit terminal 38 receives a ground signal:

- from terminal + of the trunk room lamp switch
- to terminal - of the trunk room lamp switch
- through body grounds B13 and B19.

When smart entrance control unit receives LOCK signal from key cylinder switch or keyfob and none of the described conditions exist, the vehicle security system will automatically shift to armed mode.

### Pattern B

To activate the vehicle security system, the smart entrance control unit must receive signal indicating any door [including hood (if equipped with hood switch) and trunk lid] is opened.

When the front doors are locked with key, lock/unlock switch or keyfob and then all doors are closed, the vehicle security system will automatically shift to armed mode.

## VEHICLE SECURITY SYSTEM ACTIVATION

### Pattern A

With all doors closed (including hood and trunk lid), if the key is used to lock doors, smart entrance control unit terminal 41 receives a ground signal:

- from terminal L of the front door key cylinder switch LH
- to terminal E of the front door key cylinder switch LH
- through body grounds M28 and M54.

If this signal, or lock signal from keyfob is received by the smart entrance control unit, the vehicle security system will activate automatically.

#### NOTE:

Vehicle security system can be set even though all doors are not locked.

### Pattern B

With any door open, if lock/unlock switch is used to lock doors, smart entrance control unit terminal 23 receives a ground signal:

- from terminal 14 of main power window and door lock/unlock switch

# VEHICLE SECURITY (THEFT WARNING) SYSTEM

---

- to terminal 3 of main power window and door lock/unlock switch, or
- from terminal 1 of door lock/unlock switch RH
- to terminal 5 of door lock/unlock switch RH
- through body grounds M28 and M54.

With any door open, if the key is used to lock doors, smart entrance control unit terminal 41 receives a ground signal:

- from terminal L of the front door key cylinder switch LH
- to terminal E of the front door key cylinder switch LH
- through body grounds M28 and M54.

If these signals and lock signal from keyfob are received by the smart entrance control unit and ground signals of terminals 36 and 37 are interrupted (both front doors locked), the vehicle security system will activate automatically.

## **NOTE:**

Vehicle security system can be set even though the rear door is not locked.

Once the vehicle security system has been activated, smart entrance control unit terminal 31 supplies ground to terminal 2 of the security indicator lamp.

The security indicator lamp will illuminate for approximately 30 seconds and then blink every 2.6 seconds.

Now the vehicle security system is in armed phase.

## **VEHICLE SECURITY SYSTEM ALARM OPERATION**

The vehicle security system is triggered by:

- opening a door
- opening the hood (if equipped with hood switch) or the trunk lid
- detection of battery disconnect and connect.

Once the vehicle security system is in armed phase, if the smart entrance control unit receives a ground signal at terminal 28 or 29 (door switch), 38 (trunk room lamp switch) or 27 [hood switch (if equipped)], the vehicle security system will be triggered. The headlamps flash and the horn sounds intermittently.

Power is supplied at all times:

- through 15A fuse (No. 39, located in fuse and fusible link box)
- to vehicle security lamp relay terminal 3,
- through 15A fuse (No. 40, located in fuse and fusible link box)
- to vehicle security lamp relay terminal 6,
- through 10A fuse (No. 35 located in fuse and fusible link box)
- to vehicle security lamp relay terminal 1
- through 10A fuse (No. 33, located in fuse and fusible link box)
- to horn relay terminals 1 and 5.

When the vehicle security system is triggered, ground is supplied intermittently:

- from smart entrance control unit terminal 4
- to horn relay terminal 2 and
- to vehicle security lamp relay terminal 2.

The headlamps flash and the horn sounds intermittently.

The alarm automatically turns off after about 50 seconds but will reactivate if the vehicle is tampered with again.

## **VEHICLE SECURITY SYSTEM DEACTIVATION**

To deactivate the vehicle security system, a door or trunk lid must be unlocked with the key or keyfob.

When the key is used to unlock the door, smart entrance control unit terminal 30 receives a ground signal:

- from terminal U of front door key cylinder switch LH
- to terminal E of front door key cylinder switch LH
- through body grounds M28 and M54.

When the key is used to open the trunk lid, smart entrance control unit terminal 42 receives a ground signal:

- from terminal + of the trunk lid key cylinder switch (unlock switch)
- to terminal - of the trunk lid key cylinder switch (unlock switch)

# VEHICLE SECURITY (THEFT WARNING) SYSTEM

---

- through body grounds B13 and B19.

When the smart entrance control unit receives either one of these signals or unlock signal from keyfob, the vehicle security system is deactivated. (Disarmed phase)

## PANIC ALARM OPERATION

When the remote keyless entry system (panic alarm) is triggered, ground is supplied intermittently:

- from smart entrance control unit terminal 4
- to vehicle security lamp relay terminal 2 and
- to horn relay terminal 2.

The headlamp flashes and the horn sounds intermittently.

The alarm automatically turns off after 25 seconds or when smart entrance control unit receives any signal from keyfob.

A

B

C

D

E

F

G

H

BL

J

K

L

M

# VEHICLE SECURITY (THEFT WARNING) SYSTEM

## Schematic

EIS0015F

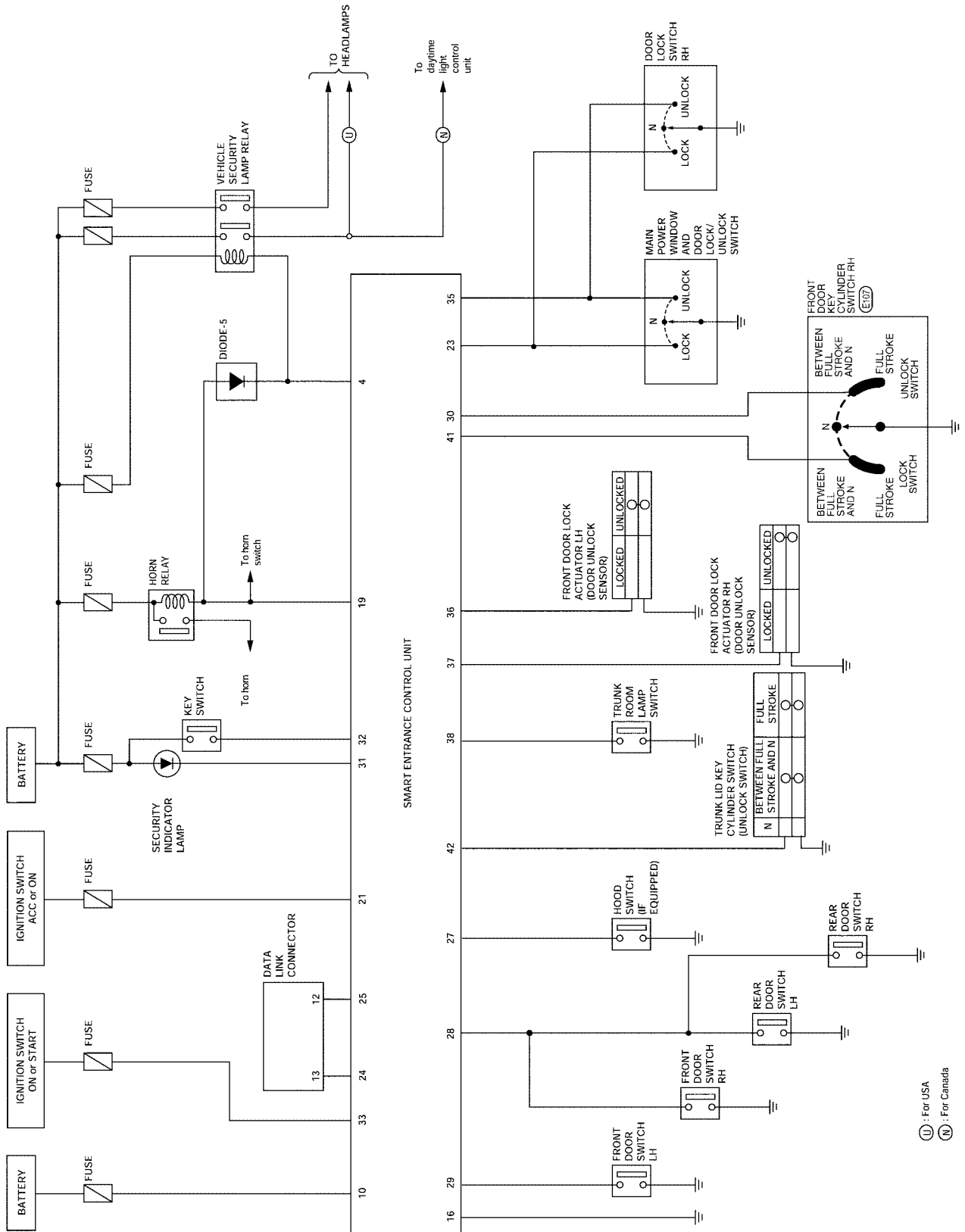

# VEHICLE SECURITY (THEFT WARNING) SYSTEM

**Wiring Diagram — VEHSEC —**  
**FIG. 1**

EIS0015G

BL-VEHSEC-01

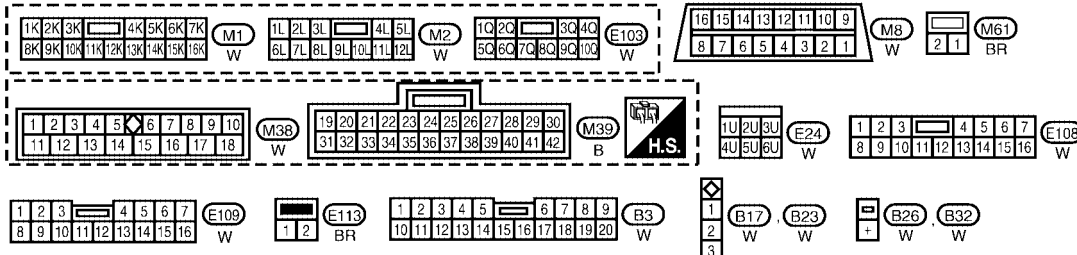
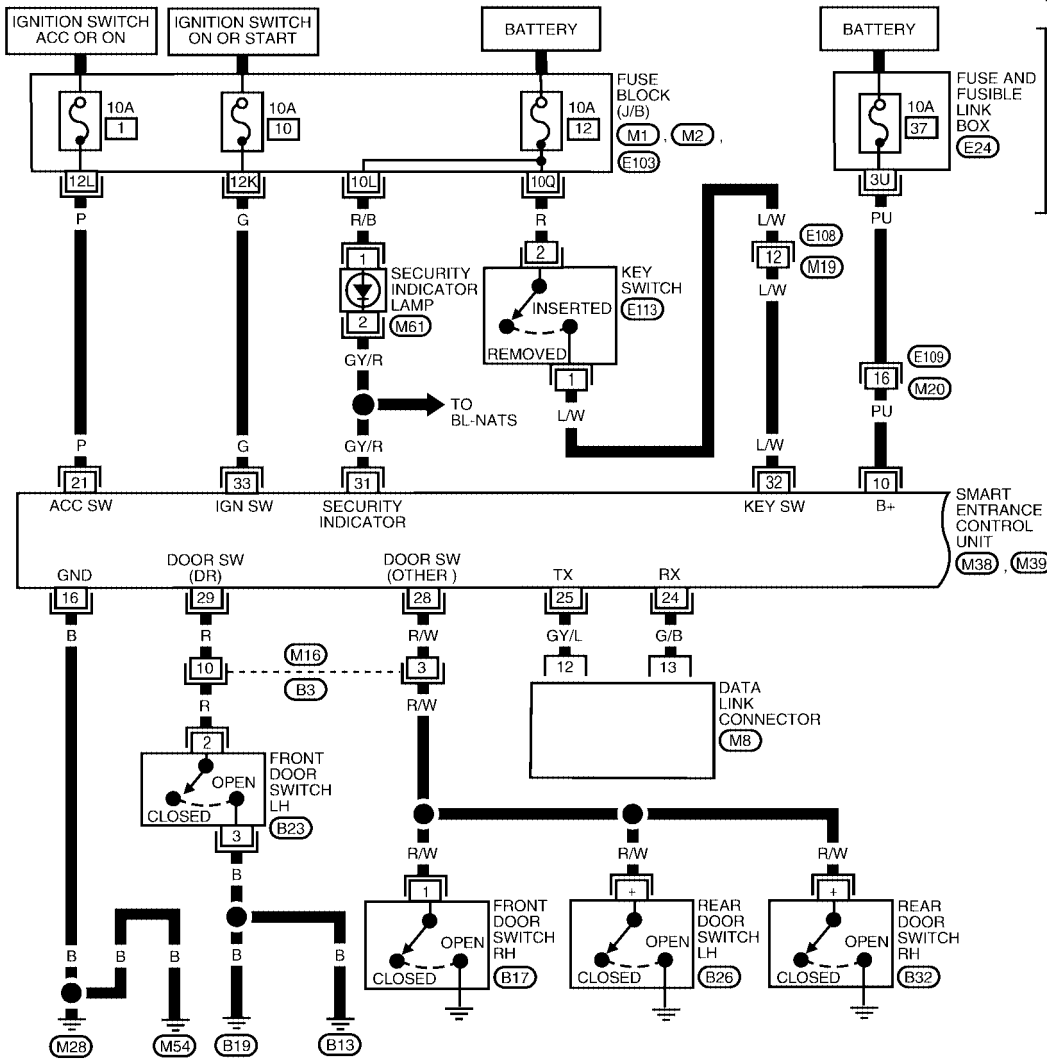

WIWA0074E

SMART ENTRANCE CONTROL UNIT TERMINALS AND REFERENCE VALUE MEASURED BETWEEN EACH TERMINAL AND GROUND				
TERMINAL	WIRE COLOR	ITEM	CONDITION	DATA (DC)
10	PU	POWER SOURCE (FUSE)	---	12V
16	B	GROUND	---	---
21	P	IGNITION SWITCH (ACC, ON)	ACC OK ON POSITION	12V
28	R/W	OTHER DOOR SWITCHES	OFF (CLOSED)	5V
			ON (OPEN)	0V
29	R	FRONT DOOR SWITCH LH	OFF (CLOSED)	5V
			ON (OPEN)	0V
32	L/W	IGNITION KEY SWITCH (INSERT)	IGNITION KEY IS INSERTED	12V
			IGNITION KEY IS REMOVED	0V
31	GY/R	VEHICLE SECURITY INDICATOR	GOES OFF	12V
			ILLUMINATES	0V
33	G	IGNITION SWITCH (ON)	IGNITION KEY IS IN ON POSITION	12V
			IGNITION SWITCH (START)	IGNITION KEY IS IN START POSITION

WEL109A

# VEHICLE SECURITY (THEFT WARNING) SYSTEM

FIG. 2

BL-VEHSEC-02

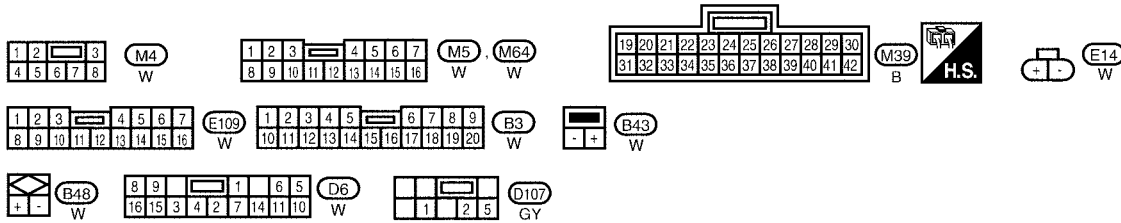
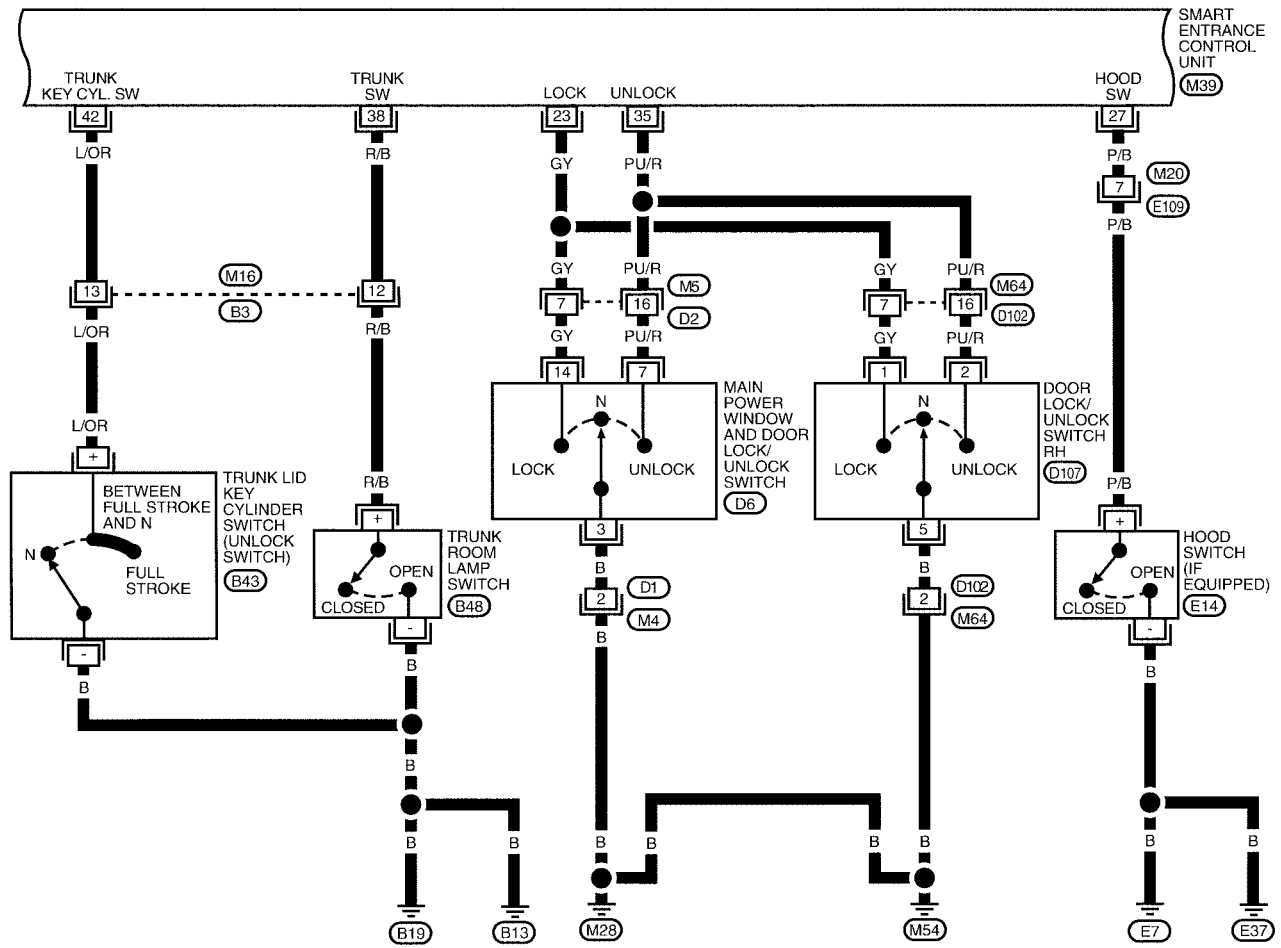

LIWA0121E

SMART ENTRANCE CONTROL UNIT TERMINALS AND REFERENCE VALUE MEASURED BETWEEN EACH TERMINAL AND GROUND

TERMINAL	WIRE COLOR	ITEM	CONDITION	DATA (DC)
23	GY	DOOR LOCK & UNLOCK SWITCHES	NEUTRAL	5V
			LOCKS	0V
27	P/B	HOOD SWITCH (IF EQUIPPED)	ON (OPEN)	0V
			OFF(CLOSED)	5V
35	PU/R	DOOR LOCK & UNLOCK SWITCHES	NEUTRAL	5V
			UNLOCKS	0V
38	R/B	TRUNK ROOM LAMP SWITCH	ON (OPEN)	0V
			OFF (CLOSED)	12V
42	L/OR	TRUNK LID KEY CYLINDER SWITCH	OFF (NEUTRAL)	5V
			ON (UNLOCK)	0V

LIA0596E



# VEHICLE SECURITY (THEFT WARNING) SYSTEM

FIG. 3

BL-VEHSEC- 03

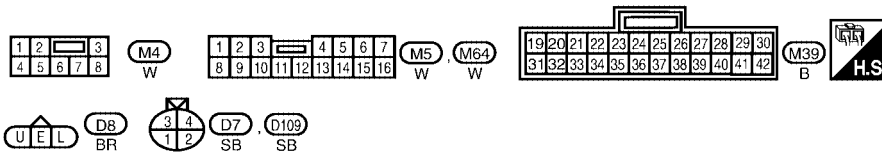
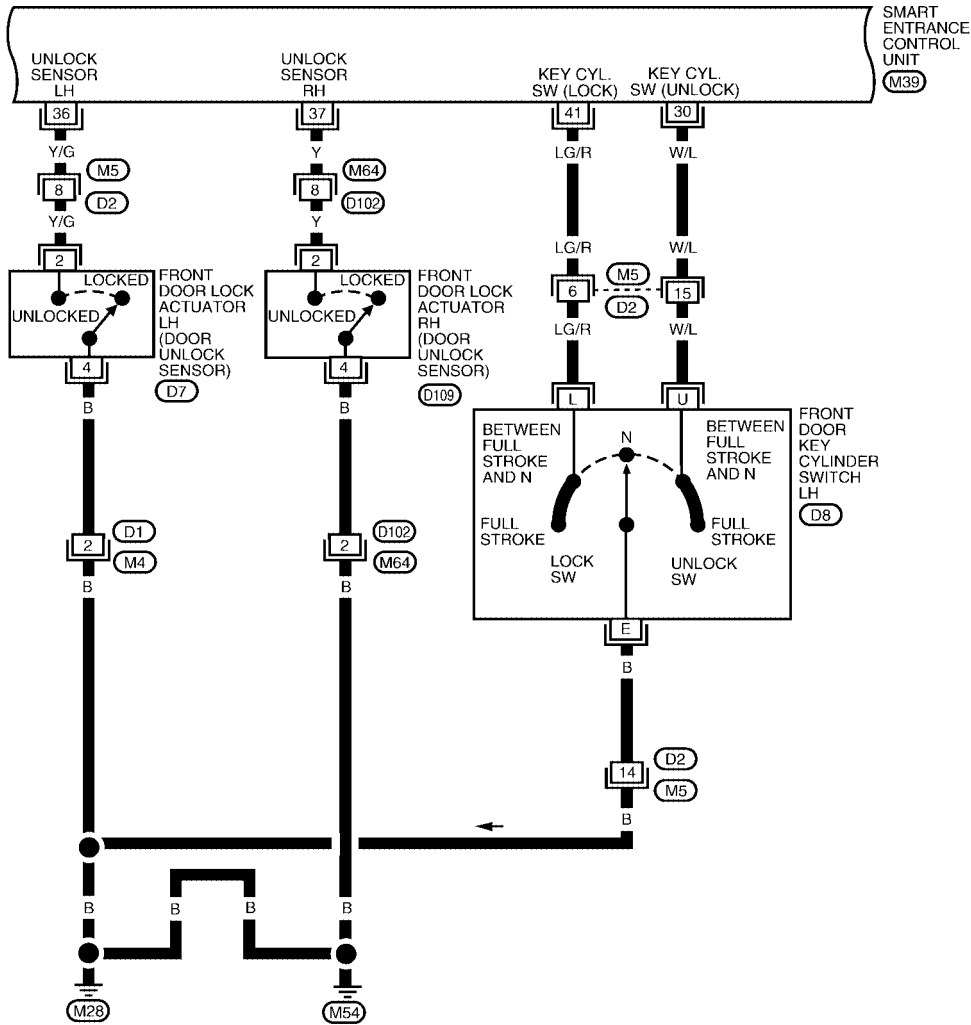

WIWA0039E

SMART ENTRANCE CONTROL UNIT TERMINALS AND REFERENCE VALUE MEASURED BETWEEN EACH TERMINAL AND GROUND

TERMINAL	WIRE COLOR	ITEM	CONDITION	DATA (DC)
30	W/L	DOOR KEY CYLINDER UNLOCK SWITCH	OFF (NEUTRAL)	5V
			ON (UNLOCKED)	0V
36	Y/G	DOOR UNLOCK SENSOR LH	DRIVER DOOR: LOCKED	5V
			DRIVER DOOR: UNLOCKED	0V
37	Y	DOOR UNLOCK SENSOR RH	PASSENGER DOOR: LOCKED	5V
			PASSENGER DOOR: UNLOCKED	0V
41	LG/R	DOOR KEY CYLINDER LOCK SWITCH	OFF (NEUTRAL)	5V
			ON (LOCKED)	0V

LEL615

# VEHICLE SECURITY (THEFT WARNING) SYSTEM

FIG. 4

BL-VEHSEC-04

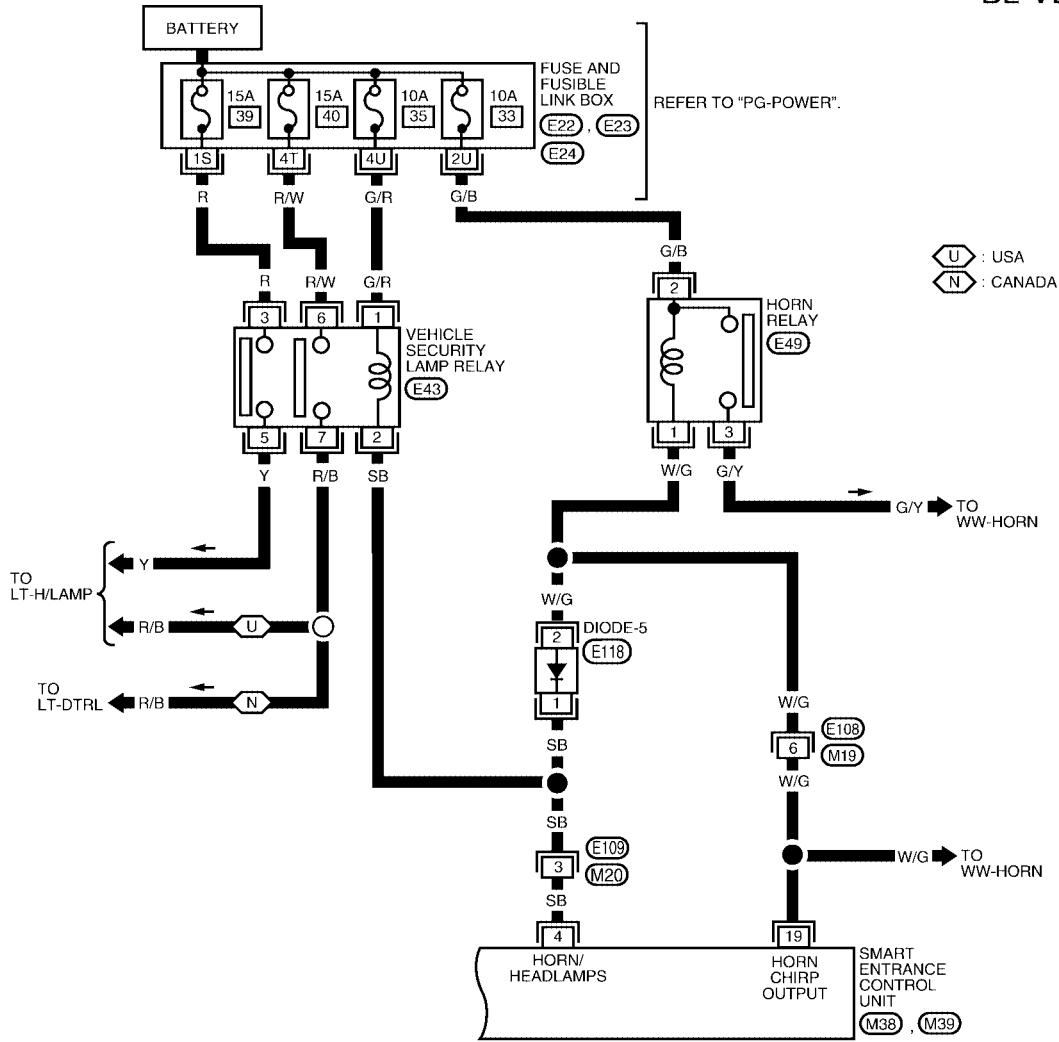

U : USA  
N : CANADA

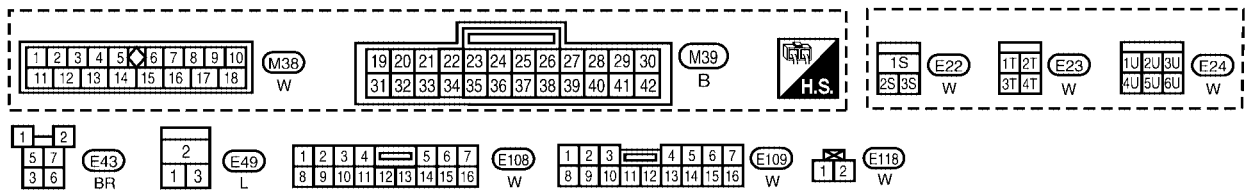

WIWA0076E

SMART ENTRANCE CONTROL UNIT TERMINALS AND REFERENCE VALUE MEASURED BETWEEN EACH TERMINAL AND GROUND

TERMINAL	WIRE COLOR	ITEM	CONDITION	DATA (DC)
4	SB	VEHICLE SECURITY HORN RELAY AND VEHICLE SECURITY WARNING LAMP RELAY	WHEN PANIC ALARM IS OPERATED USING REMOTE CONTROLLER OR WHEN ALARM IS ACTIVATED	12V TO 0V

WEL114A

# VEHICLE SECURITY (THEFT WARNING) SYSTEM

## CONSULT-II Inspection Procedure "THEFT WAR ALM"

EIS0015H

1. Turn ignition switch "OFF".

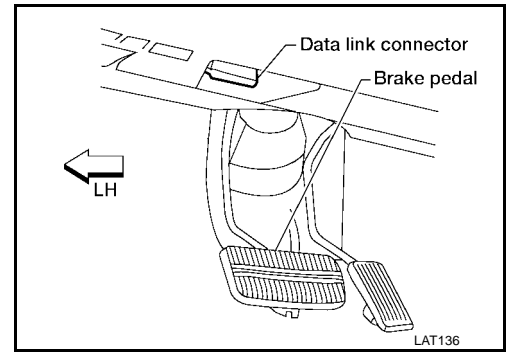

2. Connect "CONSULT-II" to the data link connector.

3. Turn ignition switch "ON".

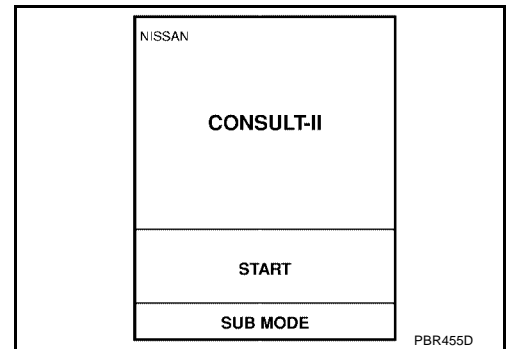

4. Touch "START".

5. Touch "SMART ENTRANCE".

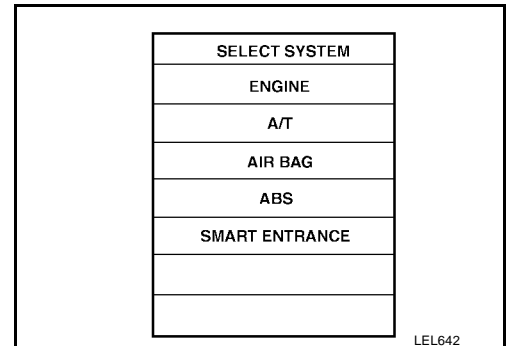

6. Touch "THEFT WAR ALM".

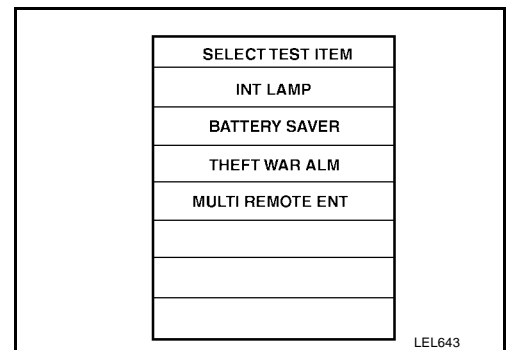

7. Select diagnosis mode.

A  
B  
C  
D  
E  
F  
G  
H  
BL  
J  
K  
L  
M

# VEHICLE SECURITY (THEFT WARNING) SYSTEM

“DATA MONITOR”, “ACTIVE TEST” and “WORK SUPPORT” are available.

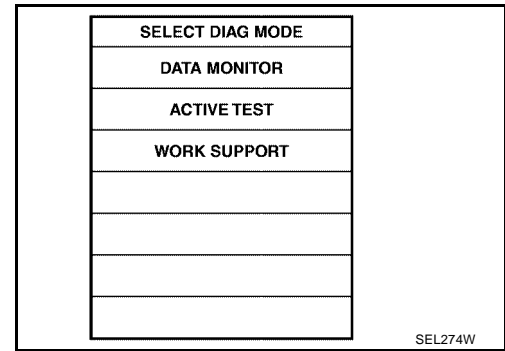

## CONSULT-II Application Item “THEFT WAR ALM”

EIS0015I

### Data Monitor

Monitored Item	Description
IGN ON SW	Indicates [ON/OFF] condition of ignition switch.
ACC ON SW	Indicates [ON/OFF] condition of ignition switch in ACC position.
KEY CYL LK SW	Indicates [ON/OFF] condition of lock signal from key cylinder switch.
KEY CYL UN SW	Indicates [ON/OFF] condition of unlock signal from key cylinder switch.
DOOR SW-ALL	Indicates [ON/OFF] condition of door switch (All).
LOCK SIG DR	Indicates [ON/OFF] condition of front door unlock sensor LH.
LOCK SIG AS	Indicates [ON/OFF] condition of front door unlock sensor RH.
TRUNK SW	Indicates [ON/OFF] condition of trunk switch.
TRUNK KEY SW	Indicates [ON/OFF] condition of trunk key cylinder switch.
HOOD SWITCH (if equipped)	Indicates [ON/OFF] condition of hood switch.
LOCK SW DR/AS	Indicates [ON/OFF] condition of lock signal from door lock/unlock switch LH and RH.
UNLK SW DR/AS	Indicates [ON/OFF] condition of unlock signal from door lock/unlock switch LH and RH.
LK BUTTON/SIG	Indicates [ON/OFF] condition of lock signal from keyfob.
UN BUTTON/SIG	Indicates [ON/OFF] condition of unlock signal from keyfob.
TRUNK BTN/SIG	Indicates [ON/OFF] condition of trunk open signal from keyfob.

### Active Test

Test Item	Description
THEFT IND	This test is able to check security indicator lamp operation. The lamp will be turned on when “ON” on CONSULT-II screen is touched.
THEFT WAR ALM	This test is able to check theft warning alarm operation. The alarm will be activated for 0.5 seconds after “ON” on CONSULT-II screen is touched.

### Work Support

Test Item	Description
THEFT ALM TRG	The switch which triggered theft warning alarm is recorded. This mode is able to confirm and erase the record of theft warning alarm. The trigger data can be erased by touching “CLEAR” on CONSULT-II screen.

# VEHICLE SECURITY (THEFT WARNING) SYSTEM

EIS0015J

## Trouble Diagnoses PRELIMINARY CHECK

The system operation is canceled by turning ignition switch to "ACC" at any step between START and ARMED in the following flow chart.

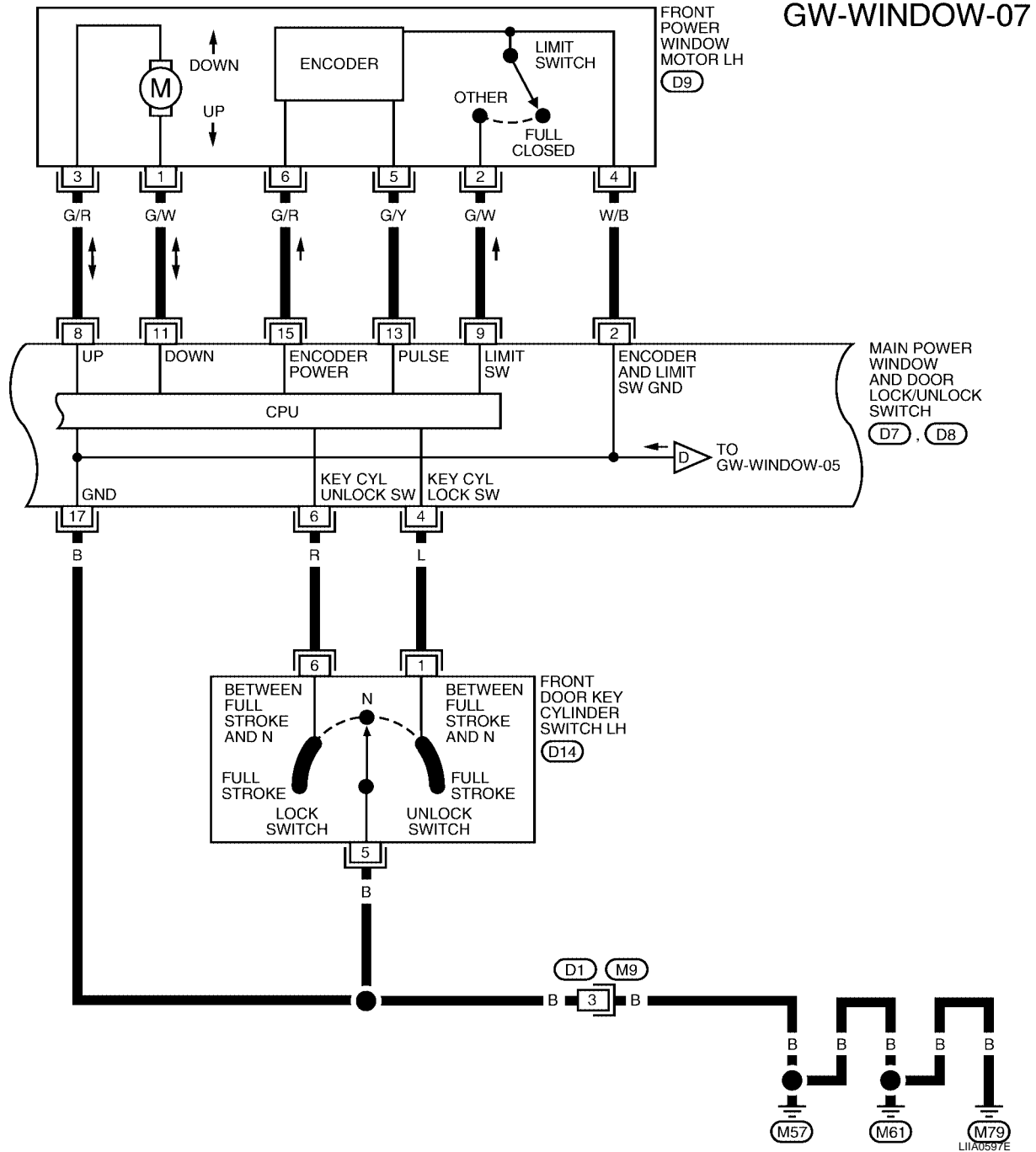

For details of "Pattern A" and "Pattern B" vehicle security system settings, refer to [BL-67, "INITIAL CONDITION TO ACTIVATE THE SYSTEM"](#).

\*: Refer to [BL-95, "NVIS \(NISSAN VEHICLE IMMOBILIZER SYSTEM — NATS\)"](#).

After performing preliminary check, go to symptom chart on next page.

# VEHICLE SECURITY (THEFT WARNING) SYSTEM

## SYMPTOM CHART

REFERENCE PAGE (BL- )		BL-77	BL-79	BL-80	BL-85	BL-87	BL-88	BL-89	BL-90	BL-92	BL-34
SYMPTOM		PRELIMINARY CHECK	POWER SUPPLY AND GROUND CIRCUIT CHECK	DOOR, HOOD AND TRUNK ROOM LAMP SWITCH CHECK	SECURITY INDICATOR LAMP CHECK	FRONT DOOR UNLOCK SENSOR CHECK	DOOR KEY CYLINDER SWITCH CHECK	TRUNK LID KEY CYLINDER SWITCH CHECK	DOOR LOCK/UNLOCK SWITCH CHECK	VEHICLE SECURITY HORN AND HEADLAMP ALARM CHECK	Check "REMOTE KEYLESS ENTRY SYSTEM" system.
1	Security indicator lamp does not illuminate for 30 seconds.	X	X		X						
	Vehicle security system cannot be set by ...	All items	X	X	X		X				
		Door outside key	X					X			
		Lock/unlock switch	X							X	
	Keyfob	X									X
2	*1 Vehicle security system does not alarm when ...	X		X							
3	Vehicle security alarm does not activate.	X		X						X	
4	Vehicle security system cannot be canceled by ...	Door outside key	X				X				
		Trunk lid key	X					X			
		Keyfob	X								

X: Applicable

\*1: Make sure the system is in the armed phase.

**Before starting trouble diagnoses above, perform [BL-77, "PRELIMINARY CHECK"](#) .**

Symptom numbers in the symptom chart correspond with those of preliminary check.

# VEHICLE SECURITY (THEFT WARNING) SYSTEM

## POWER SUPPLY AND GROUND CIRCUIT CHECK

### Power Supply Circuit Check

Terminals		Ignition switch position		
(+)	(-)	OFF	ACC	ON
10	Ground	Battery voltage	Battery voltage	Battery voltage
21	Ground	0V	Battery voltage	Battery voltage
33	Ground	0V	0V	Battery voltage

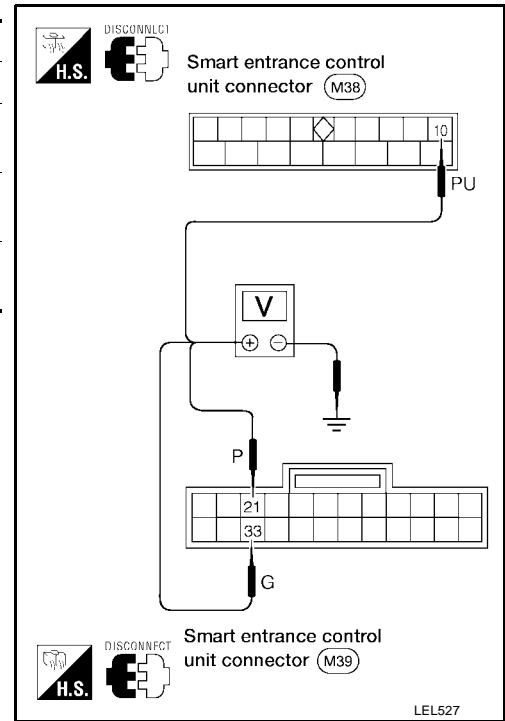

### Ground Circuit Check

Terminals	Continuity
16 - Ground	Yes

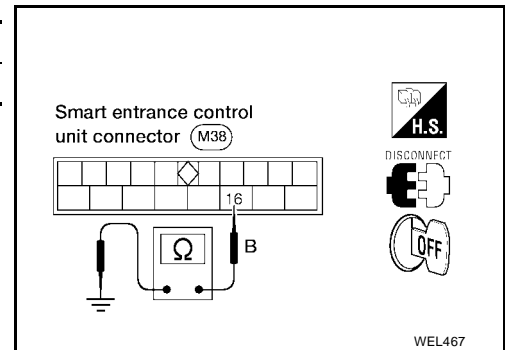

A  
B  
C  
D  
E  
F  
G  
H

BL

J  
K  
L  
M

# VEHICLE SECURITY (THEFT WARNING) SYSTEM

## DOOR, HOOD AND TRUNK ROOM LAMP SWITCH CHECK

### Door Switch Check

#### 1. CHECK DOOR SWITCH INPUT SIGNAL

##### With CONSULT-II

Check door switches ("DOOR SW-ALL") in "DATA MONITOR" mode with CONSULT-II.

DATA MONITOR	
MONITOR	
DOOR SW-ALL	OFF

When any doors are open:  
**DOOR SW-ALL ON**

When all doors are closed:  
**DOOR SW-ALL OFF**

SEL323W

##### Without CONSULT-II

Check voltage between smart entrance control unit harness connector terminals 28 or 29 and ground.

Smart entrance control unit connector (M39)

	Terminals		Condition	Voltage [V]
	(+)	(-)		
Front door switch LH	29	Ground	Open	0
			Closed	Approx. 5
Other door switches	28	Ground	Open	0
			Closed	Approx. 5

WEL500

Refer to [BL-71, "FIG. 1"](#) .

#### OK or NG

- OK >> Door switch is OK. Check hood switch (if equipped), refer to [BL-82, "Hood Switch Check \(if equipped\)"](#) or check trunk room lamp switch, refer to [BL-84, "Trunk Room Lamp Switch Check"](#) .
- NG >> GO TO 2.



# VEHICLE SECURITY (THEFT WARNING) SYSTEM

## 2. CHECK DOOR SWITCH

1. Disconnect door switch connector.
2. Check continuity between door switch terminals.

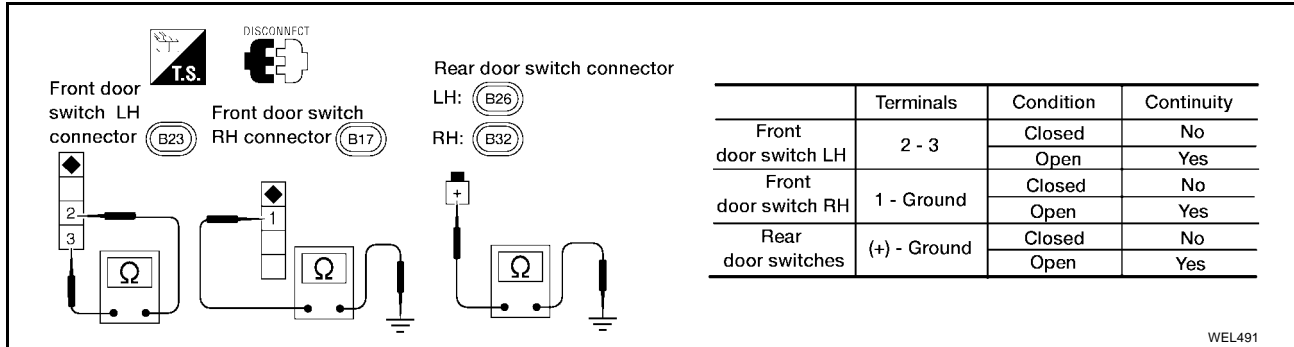

OK or NG

OK >> Check the following.

- Door switch ground circuit (Front, rear door) or door switch ground condition
- Harness for open or short between smart entrance control unit and door switch

NG >> Replace door switch.

A  
B  
C  
D  
E  
F  
G  
H  
J  
K  
L  
M

BL

# VEHICLE SECURITY (THEFT WARNING) SYSTEM

## Hood Switch Check (if equipped)

### 1. CHECK HOOD SWITCH FITTING CONDITION

Check condition and installation of hood switch.

OK or NG

OK >> GO TO 2.

NG >> Adjust installation of hood switch or hood.

### 2. CHECK HOOD SWITCH INPUT SIGNAL

#### Ⓜ With CONSULT-II

Check hood switch ("HOOD SWITCH") in "DATA MONITOR" mode with CONSULT-II.

DATA MONITOR	
MONITOR	
HOOD SWITCH	OFF

When hood is open:  
**HOOD SWITCH ON**

When hood is closed:  
**HOOD SWITCH OFF**

SEL354W

#### ⊗ Without CONSULT-II

Check voltage between smart entrance control unit harness connector terminal 27 and ground.

Smart entrance control unit connector (M39)

Voltage [V]:  
Engine hood is open.  
0  
Engine hood is closed.  
Approx. 5

LEL528

Refer to [BL-72, "FIG. 2"](#).

OK or NG

OK >> Hood switch is OK, and go to trunk room lamp switch check.

NG >> GO TO 3.

# VEHICLE SECURITY (THEFT WARNING) SYSTEM

## 3. CHECK HOOD SWITCH

1. Disconnect hood switch connector.
2. Check continuity between hood switch terminals + and -.

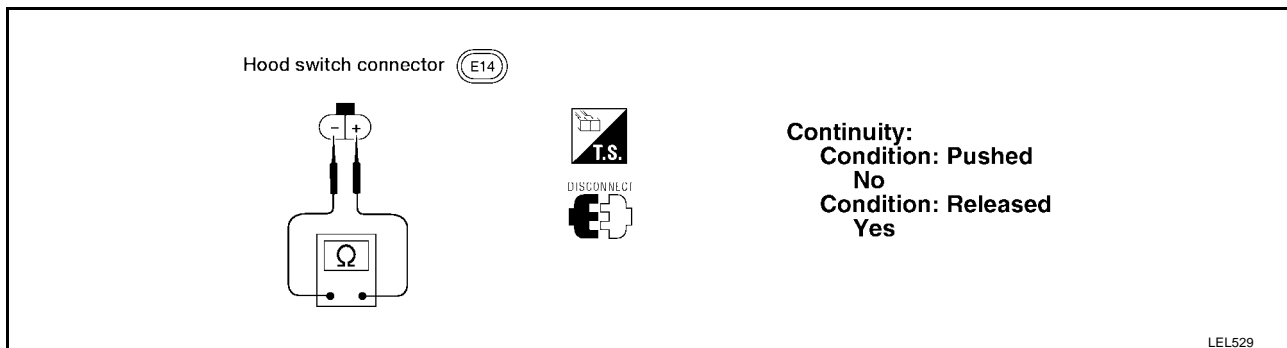

### OK or NG

- OK >> Check the following.
- Hood switch ground circuit
  - Harness for open or short between smart entrance control unit and hood switch
- NG >> Replace hood switch.

A  
B  
C  
D  
E  
F  
G  
H  
J  
K  
L  
M

BL

# VEHICLE SECURITY (THEFT WARNING) SYSTEM

## Trunk Room Lamp Switch Check

### 1. CHECK TRUNK ROOM LAMP SWITCH INPUT SIGNAL

#### Ⓜ With CONSULT-II

Check trunk room lamp switch ("TRUNK SW"), in "DATA MONITOR" mode with CONSULT-II.

DATA MONITOR	
MONITOR	
TRUNK SW	OFF

When trunk lid is open:  
**TRUNK SW ON**

When trunk lid is closed:  
**TRUNK SW OFF**

SEL355W

#### ⊗ Without CONSULT-II

Check voltage between smart entrance control unit harness connector terminal 38 and ground.

Smart entrance control unit connector (M39)

Voltage [V]:  
Trunk lid is open.  
Approx. 0  
Trunk lid is closed.  
Approx. 12

CONNECT

OFF

LEL530

Refer to [BL-72, "FIG. 2"](#).

OK or NG

- OK >> Trunk room lamp switch is OK.
- NG >> GO TO 2.

### 2. CHECK TRUNK ROOM LAMP SWITCH

1. Disconnect trunk room lamp switch connector.
2. Check continuity between trunk room lamp switch terminals + and -.

Trunk room lamp switch connector (B48)

Continuity:  
Condition: Closed  
No  
Condition: Open  
Yes

T.S.

DISCONNECT

LEL531

OK or NG

- OK >> Check the following.
  - Trunk room lamp switch ground circuit
  - Harness for open or short between smart entrance control unit and trunk room lamp switch
- NG >> Replace trunk room lamp switch.

# VEHICLE SECURITY (THEFT WARNING) SYSTEM

## SECURITY INDICATOR LAMP CHECK

### 1. CHECK INDICATOR LAMP OPERATION

#### ④ With CONSULT-II

1. Select "ACTIVE TEST" in "THEFT WAR ALM" with CONSULT-II.
2. Select "THEFT IND" and touch "ON".

Security indicator lamp should illuminate.

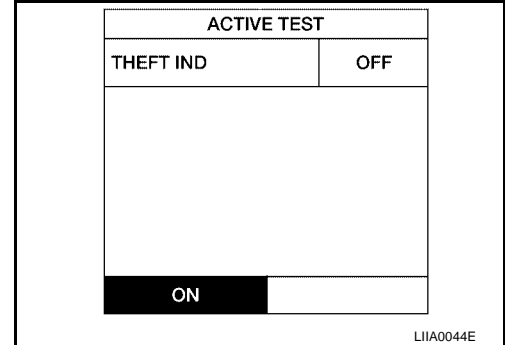

#### ⊗ Without CONSULT-II

1. Disconnect smart entrance control unit harness connector.
2. Check voltage between smart entrance control unit harness connector terminal 31 and ground.

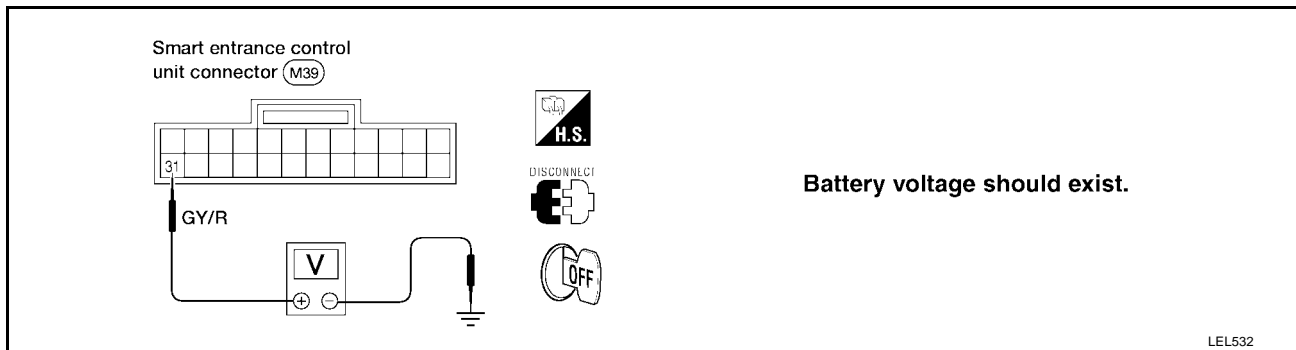

Refer to [BL-71, "FIG. 1"](#) .

OK or NG

- OK >> Security indicator lamp is OK.
- NG >> GO TO 2.

### 2. CHECK SECURITY INDICATOR LAMP

Refer to [BL-71, "FIG. 1"](#) .

OK or NG

- OK >> GO TO 3.
- NG >> Replace security indicator lamp.

# VEHICLE SECURITY (THEFT WARNING) SYSTEM

## 3. CHECK POWER SUPPLY CIRCUIT FOR SECURITY INDICATOR LAMP

1. Disconnect security indicator lamp connector.
2. Check voltage between security indicator lamp terminal 1 and ground.

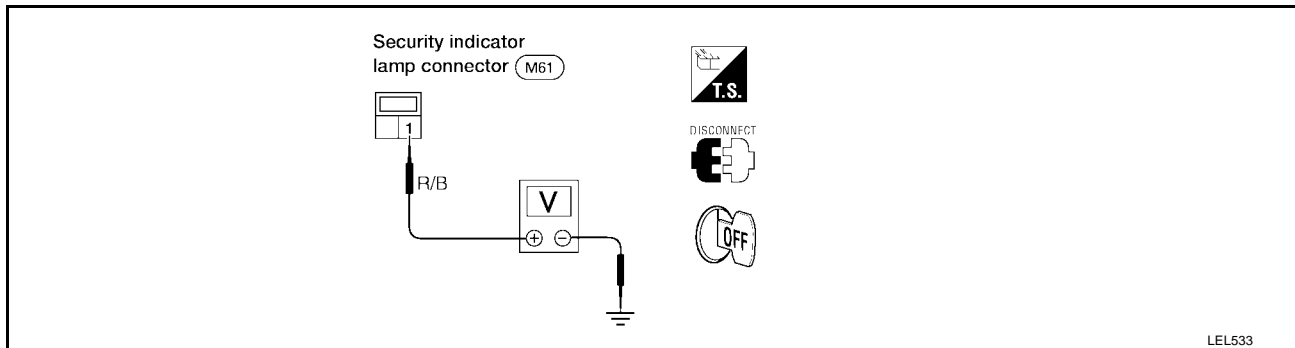

Does battery voltage exist?

- Yes >> Check harness for open or short between security indicator lamp and smart entrance control unit.
- No >> Check the following.
- 10A fuse [No. 12, located in fuse block (J/B)]
  - Harness for open or short between security indicator lamp and fuse

# VEHICLE SECURITY (THEFT WARNING) SYSTEM

## FRONT DOOR UNLOCK SENSOR CHECK

### 1. CHECK FRONT DOOR UNLOCK SENSOR INPUT SIGNAL

#### With CONSULT-II

Check front unlock sensor ("LOCK SIG DR", "LOCK SIG AS") in "DATA MONITOR" with CONSULT-II.

DATA MONITOR	
MONITOR	
LOCK SIG DR	OFF
LOCK SIG AS	OFF

When door is locked:  
**LOCK SIG DR OFF**  
**LOCK SIG AS OFF**

When door is unlocked:  
**LOCK SIG DR ON**  
**LOCK SIG AS ON**

SEL357W

#### Without CONSULT-II

Check voltage between smart entrance control unit harness connector terminal 36 or 37 and ground.

Smart entrance control unit connector (M39)

	Terminals		Condition	Voltage [V]
	(+)	(-)		
Front door LH	36	Ground	Locked	Approx. 5
			Unlocked	0
Front door RH	37	Ground	Locked	Approx. 5
			Unlocked	0

LEL534

Refer to [BL-73, "FIG. 3"](#) .

OK or NG

- OK >> Door unlock sensor is OK.
- NG >> GO TO 2.

### 2. CHECK FRONT DOOR UNLOCK SENSOR

1. Disconnect door lock actuator connector.
2. Check continuity between door lock actuator terminals.

Front door lock actuator connector

LH: (D7)

RH: (D109)

**Continuity:**

**Condition: Locked**  
No

**Condition: Unlocked**  
Yes

LEL535

OK or NG

- OK >> Check the following.
  - Door unlock sensor ground circuit
  - Harness for open or short between smart entrance control unit and door unlock sensor
- NG >> Replace door lock actuator.

# VEHICLE SECURITY (THEFT WARNING) SYSTEM

## DOOR KEY CYLINDER SWITCH CHECK

### 1. CHECK DOOR KEY CYLINDER SWITCH INPUT SIGNAL (LOCK/UNLOCK SIGNAL)

#### Ⓜ With CONSULT-II

Check front door key cylinder switch ("KEY CYL LK-SW"/"KEY CYL UN-SW") in "DATA MONITOR" mode with CONSULT-II.

DATA MONITOR	
MONITOR	
KEY CYL LK-SW	OFF
KEY CYL UN-SW	OFF

When key inserted in front key cylinder is turned to LOCK:  
**KEY CYL LK-SW ON**

When key inserted in front key cylinder is turned to UNLOCK:  
**KEY CYL UN-SW ON**

SEL342W

#### ⊗ Without CONSULT-II

Check voltage between smart entrance control unit harness connector terminal 30 or 41 and ground.

Smart entrance control unit connector (M39)

Terminals		Key position	Voltage [V]
(+)	(-)		
41	Ground	Neutral/Unlock	Approx. 5
		Lock	0
30	Ground	Neutral/Lock	Approx. 5
		Unlock	0

WEL502

Refer to [BL-73, "FIG. 3"](#).

#### OK or NG

- OK >> Door key cylinder switch is OK.
- NG >> GO TO 2.

### 2. CHECK DOOR KEY CYLINDER SWITCH

1. Disconnect door key cylinder switch connector.
2. Check continuity between door key cylinder switch connector D8 terminals.

Front door key cylinder switch LH connector

Ⓜ : Ground terminal  
Ⓧ : Door unlock switch terminal  
Ⓛ : Door lock switch terminal

Terminals	Key position	Continuity
Ⓛ - Ⓜ	Neutral/Unlock	No
	Lock	Yes
Ⓧ - Ⓜ	Neutral/Lock	No
	Unlock	Yes

LEL101A

#### OK or NG

- OK >> Check the following.
  - Door key cylinder switch ground circuit
  - Harness for open or short between smart entrance control unit and door key cylinder switch
- NG >> Replace door key cylinder switch.



# VEHICLE SECURITY (THEFT WARNING) SYSTEM

## TRUNK LID KEY CYLINDER SWITCH CHECK

### 1. CHECK TRUNK LID KEY CYLINDER SWITCH INPUT SIGNAL (UNLOCK SIGNAL)

#### With CONSULT-II

Check trunk lid key cylinder switch ("TRUNK KEY SW") in "DATA MONITOR" mode with CONSULT-II.

DATA MONITOR	
MONITOR	
TRUNK KEY SW	OFF

When key in key cylinder is at Neutral position:  
**TRUNK KEY SW OFF**

When key in key cylinder is at Unlock position:  
**TRUNK KEY SW ON**

SEL358W

#### Without CONSULT-II

Check voltage between smart entrance control unit harness connector terminal 42 and ground.

Continuity exists

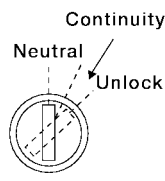

Smart entrance control unit connector (M39)

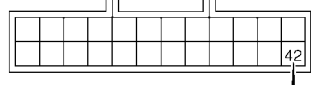



CONNECT



Terminals		Key position	Voltage [V]
(+)	(-)		
42	Ground	Neutral	Approx. 5
		Unlock	0

LEL536

Refer to [BL-72, "FIG. 2"](#) .

OK or NG

- OK >> Trunk lid key cylinder switch is OK.
- NG >> GO TO 2.

### 2. CHECK TRUNK LID KEY CYLINDER SWITCH

1. Disconnect trunk lid key cylinder switch connector.
2. Check continuity between trunk lid key cylinder switch terminals.

Trunk lid key cylinder switch (B43)

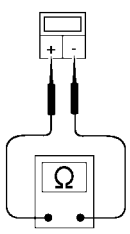



DISCONNECT



Key position	Continuity
Neutral	No
Unlock	Yes

LEL537

OK or NG

- OK >> Check the following.
  - Trunk lid key cylinder switch ground circuit
  - Harness for open or short between smart entrance control unit and trunk lid key cylinder switch
- NG >> Replace trunk lid key cylinder switch.

# VEHICLE SECURITY (THEFT WARNING) SYSTEM

## DOOR LOCK/UNLOCK SWITCH CHECK

### 1. CHECK DOOR LOCK/UNLOCK SWITCH INPUT SIGNAL

#### Ⓟ With CONSULT-II

Check door lock/unlock switch ("LOCK SW DR/AS"/"UNLK SW DR/AS") in "DATA MONITOR" mode with CONSULT-II.

DATA MONITOR	
MONITOR	
LOCK SW DR/AS	OFF
UNLK SW DR/AS	OFF

When lock/unlock switch is turned to LOCK:  
**LOCK SW DR/AS ON**

When lock/unlock switch is turned to UNLOCK:  
**UNLK SW DR/AS ON**

SEL341W

#### ⊗ Without CONSULT-II

1. Disconnect smart entrance control unit harness connector.
2. Check continuity between smart entrance control unit harness connector terminal 23 or 35 and ground.

Smart entrance control unit connector (M39)

DISCONNECT

Terminals	Door lock/unlock switch (LH or RH) condition	Continuity
23 - Ground	Lock	Yes
	N and Unlock	No
35 - Ground	Unlock	Yes
	N and Lock	No

WEL501

Refer to [BL-72, "FIG. 2"](#) .

#### OK or NG

- OK >> Door lock/unlock switch is OK.  
 NG >> GO TO 2.

# VEHICLE SECURITY (THEFT WARNING) SYSTEM

## 2. CHECK DOOR LOCK/UNLOCK SWITCH

1. Disconnect door lock/unlock switch harness connector.
2. Check continuity between each door lock/unlock switch terminal.
  - Main power window and door lock/unlock switch



Main power window and door lock/unlock switch connector (D6)

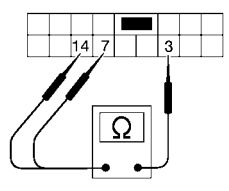

Condition	Terminals		
	3	7	14
Lock	○	—	○
N	No continuity		
Unlock	○	—	○

WEL494

- Door lock/unlock switch RH



Door lock/unlock switch RH connector (D107)

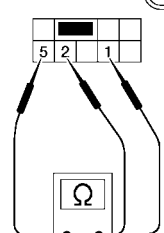

Condition	Terminals		
	1	2	5
Lock	○	—	○
N	No continuity		
Unlock	○	—	○

WEL495

### OK or NG

- OK >> Check the following.
- Ground circuit for door lock/unlock switch
  - Harness for open or short between door lock/unlock switch and smart entrance control unit
- NG >> Replace door lock/unlock switch.

A  
B  
C  
D  
E  
F  
G  
H  
J  
K  
L  
M

BL

# VEHICLE SECURITY (THEFT WARNING) SYSTEM

## HORN AND HEADLAMP ALARM CHECK

### 1. CHECK BASE HORN SYSTEM OPERATION

Operate vehicle horn.

OK or NG

OK >> GO TO 2.

NG >> Check base horn system. Refer to [WW-9, "Wiring Diagram — HORN —"](#).

### 2. CHECK HORN AND HEADLAMP ALARM OPERATION

#### Ⓟ With CONSULT-II

1. Select "ACTIVE TEST" in "THEFT WAR ALM" with CONSULT-II.
2. Select "THEFT WAR ALM" and touch "ON".

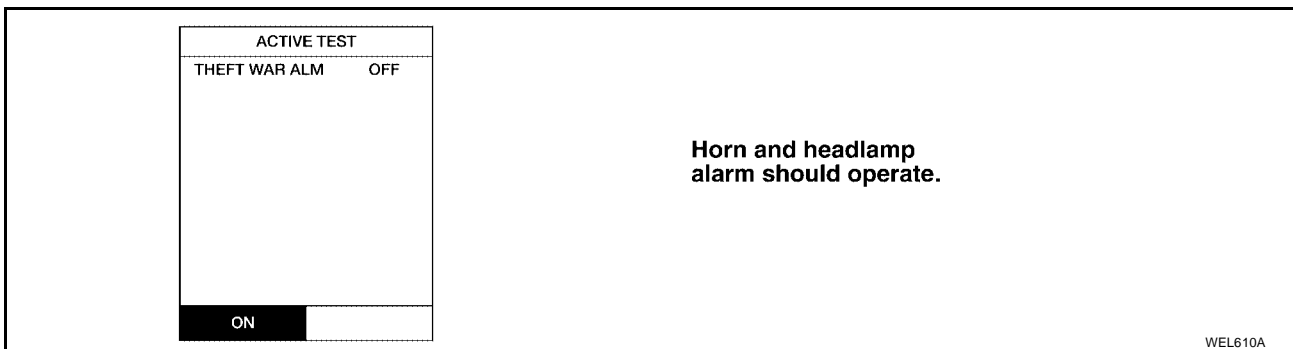

#### ⊗ Without CONSULT-II

1. Disconnect smart entrance control unit harness connector.
2. Apply ground to smart entrance control unit harness connector terminal 4.

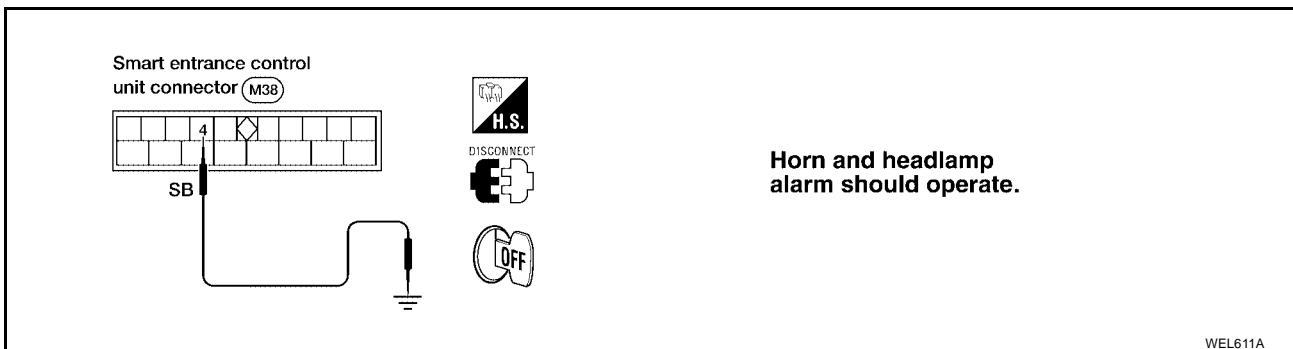

Refer to [BL-74, "FIG. 4"](#).

OK or NG

OK >> Horn and headlamp alarm is OK.

NG >> GO TO 3.

### 3. CHECK VEHICLE SECURITY LAMP RELAY

Check vehicle security lamp relay. Refer to [BL-94, "VEHICLE SECURITY LAMP RELAY"](#).

OK or NG

OK >> GO TO 4.

NG >> Replace relay.

# VEHICLE SECURITY (THEFT WARNING) SYSTEM

## 4. CHECK POWER SUPPLY FOR VEHICLE SECURITY LAMP RELAY

1. Disconnect vehicle security lamp relay connector.
2. Check voltage between vehicle security lamp relay connector E43 terminal 1 (G/R) and ground.

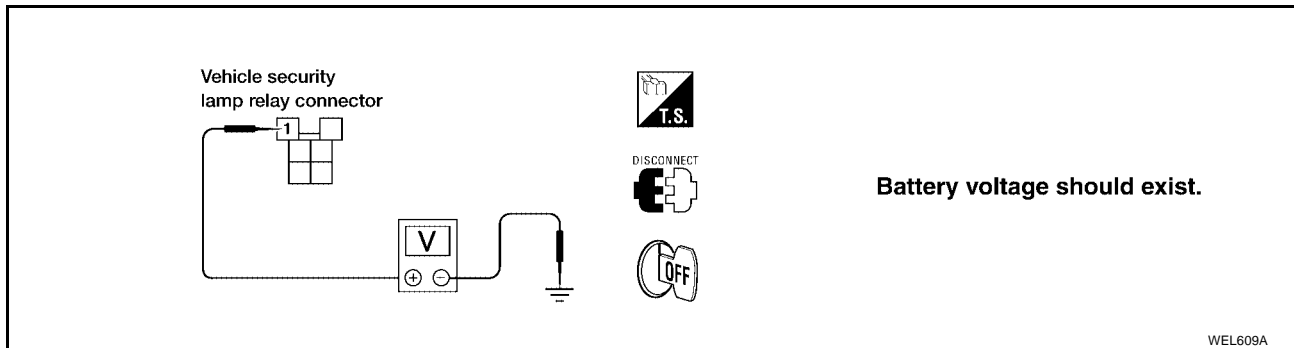

Does battery voltage exist?

Yes >> GO TO 5.

No >> Check the following.

- 10A fuse (No. 35 located in the fuse and fusible link box)
- Harness for open or short between relay and fuse

## 5. CHECK VEHICLE SECURITY LAMP RELAY CIRCUIT

1. Check voltage between terminals of vehicle security lamp relay connector E43.

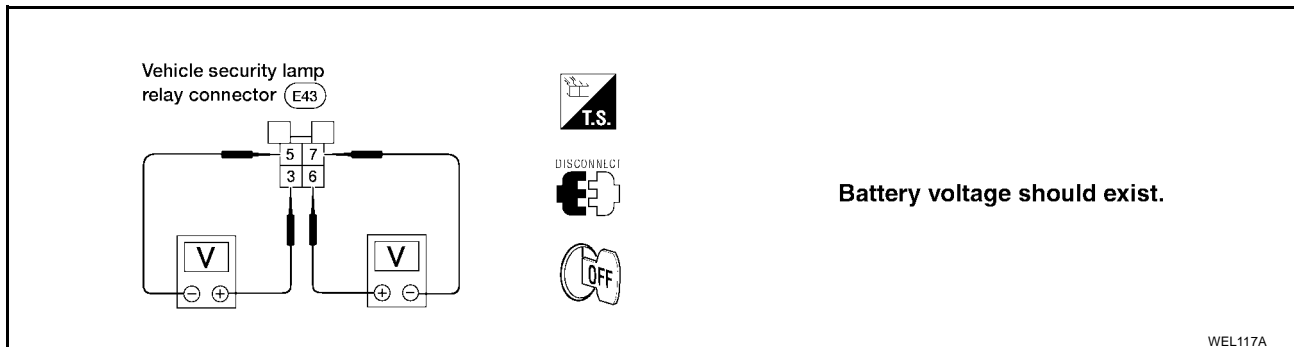

OK or NG

OK >> Check the following.

- Harness for open between smart entrance control unit terminal 4 and relay
- Harness for open or short between smart entrance control unit terminal 4 and horn relay
- Diode-4 for open
- Replace smart entrance control unit

NG >> Check the following.

- Harness for open or short between vehicle security lamp relay and fuses
- Harness for open or short between vehicle security lamp relay and headlamp system

# VEHICLE SECURITY (THEFT WARNING) SYSTEM

EIS0015K

## Electrical Components Inspection VEHICLE SECURITY LAMP RELAY

Check continuity between terminals 3 and 5, 6 and 7.

Condition	Continuity
12V direct current supply between terminals 1 and 2	Yes
No current supply	No

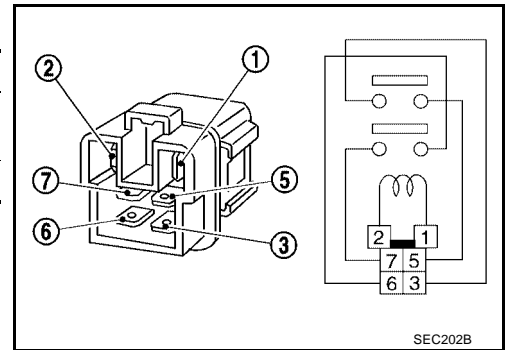



# NVIS (NISSAN VEHICLE IMMOBILIZER SYSTEM — NATS)

EIS0015M

## System Description

NVIS (Nissan Vehicle Immobilizer System—NATS) has the following immobilizer functions:

- Since only NVIS (NATS) ignition keys, whose ID nos. have been registered into the ECM and IMMU of NVIS (NATS), allow the engine to run, operation of a stolen vehicle without a NVIS (NATS) registered key is prevented by NVIS (NATS).  
That is to say, NVIS (NATS) will immobilize the engine if someone tries to start it without the registered key of NVIS (NATS).
- All of the originally supplied ignition key IDs have been NVIS (NATS) registered.  
If requested by the vehicle owner, a maximum of five key IDs can be registered into the NVIS (NATS) components.
- The security indicator lamp blinks when the ignition switch is in “OFF” or “ACC” position. Therefore, NVIS (NATS) warns outsiders that the vehicle is equipped with the system.
- When NVIS (NATS) detects trouble, the security indicator lamp lights up while ignition key is in the “ON” position.
- NVIS (NATS) trouble diagnoses, system initialization and additional registration for other NVIS (NATS) ignition key IDs must be carried out using CONSULT-II hardware and CONSULT-II NVIS (NATS) software. Regarding the procedures for NVIS (NATS) initialization and NVIS (NATS) ignition key ID registration, refer to CONSULT-II OPERATION MANUAL IVIS/NVIS.
- **When servicing a malfunction of the NVIS (indicated by lighting up of Security Indicator Lamp) or registering another NVIS ignition key ID no., it is necessary to re-register original key identification.**

Therefore, be sure to receive ALL KEYS from vehicle owner.

## System Composition

EIS0015N

The immobilizer function of the NVIS (NATS) consists of the following:

- NVIS (NATS) ignition key
- NVIS (NATS) immobilizer control unit (IMMU) located in the ignition key cylinder
- ECM
- Security indicator lamp

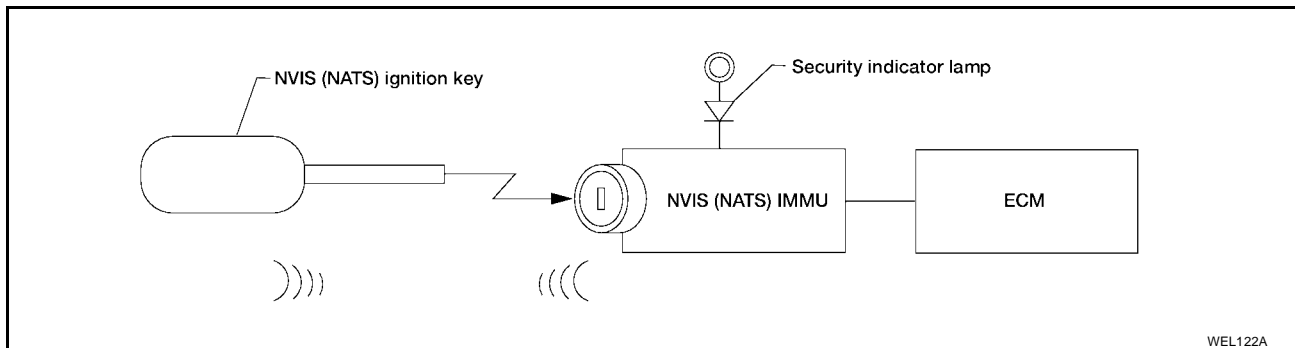





# NVIS (NISSAN VEHICLE IMMOBILIZER SYSTEM — NATS)

IMMOBILIZER CONTROL UNIT TERMINALS AND REFERENCE VALUE MEASURED BETWEEN EACH TERMINAL AND GROUND

TERMINAL	WIRE COLOR	ITEM	CONDITION	DATA (DC)
4	B	GROUND	—	—
5	GY/R	VEHICLE SECURITY INDICATOR	GOES OFF	12V
			ILLUMINATES	0V
7	G/W	IGNITION SWITCH (ON)	IGNITION KEY IS IN ON POSITION	12V
		IGNITION SWITCH (START)	IGNITION KEY IS IN START POSITION	12V
8	W/L	POWER SOURCE (FUSE)	—	12V

## CONSULT-II CONSULT-II INSPECTION PROCEDURE

EIS0015Q

1. Turn ignition switch OFF.

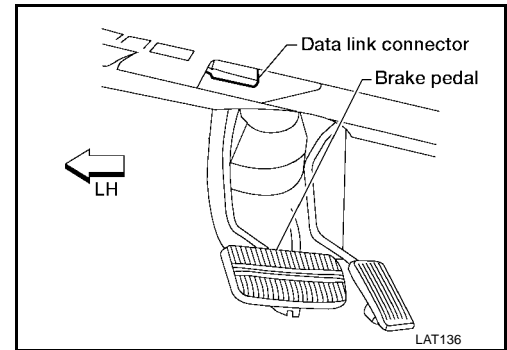

2. Connect "CONSULT-II" to data link connector.
3. Insert NVIS (NATS) program card into CONSULT-II.

**Program card : NATS (AEN02C)**

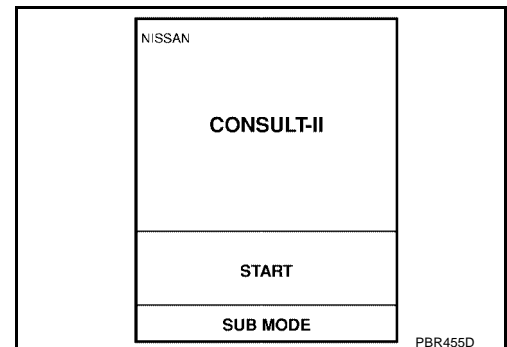

4. Turn ignition switch ON.
5. Touch "START".
6. Select "NATS V.5.0".

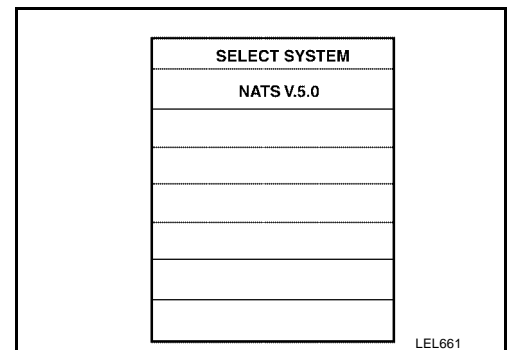



## NVIS (NISSAN VEHICLE IMMOBILIZER SYSTEM — NATS)

### NVIS (NATS) SELF-DIAGNOSTIC RESULTS ITEM CHART

Detected items (NATS program card screen terms)	P No. Code (Self-diagnostic result of "ENGINE")	Malfunction is detected when .....	Reference page
ECM INT CIRC-IMMU	NATS MAL-FUNCTION P1613	The malfunction of ECM internal circuit of IMMU communication line is detected.	<a href="#">BL-103</a>
CHAIN OF ECM-IMMU	NATS MAL-FUNCTION P1612	Communication impossible between ECM and IMMU (In rare cases, "CHAIN OF ECM-IMMU" might be stored during key registration procedure, even if the system is not malfunctioning.)	<a href="#">BL-104</a>
DIFFERENCE OF KEY	NATS MAL-FUNCTION P1615	IMMU can receive the key ID signal but the result of ID verification between key ID and IMMU is NG.	<a href="#">BL-108</a>
CHAIN OF IMMU-KEY	NATS MAL-FUNCTION P1614	IMMU cannot receive the key ID signal.	<a href="#">BL-109</a>
ID DISCORD, IMM-ECM	NATS MAL-FUNCTION P1611	The result of ID verification between IMMU and ECM is NG. System initialization is required.	<a href="#">BL-110</a>
LOCK MODE	NATS MAL-FUNCTION P1610	When the starting operation is carried out five or more times consecutively under the following conditions, NVIS (NATS) will shift the mode to one which prevents the engine from being started. <ul style="list-style-type: none"> <li>● Unregistered ignition key is used.</li> <li>● IMMU or ECM is malfunctioning.</li> </ul>	<a href="#">BL-113</a>
DON'T ERASE BEFORE CHECKING ENG DIAG	—	Any engine trouble codes except NVIS (NATS) trouble codes have been detected in ECM.	<a href="#">BL-101</a>

# NVIS (NISSAN VEHICLE IMMOBILIZER SYSTEM — NATS)

EIS0015R

## Trouble Diagnoses WORK FLOW

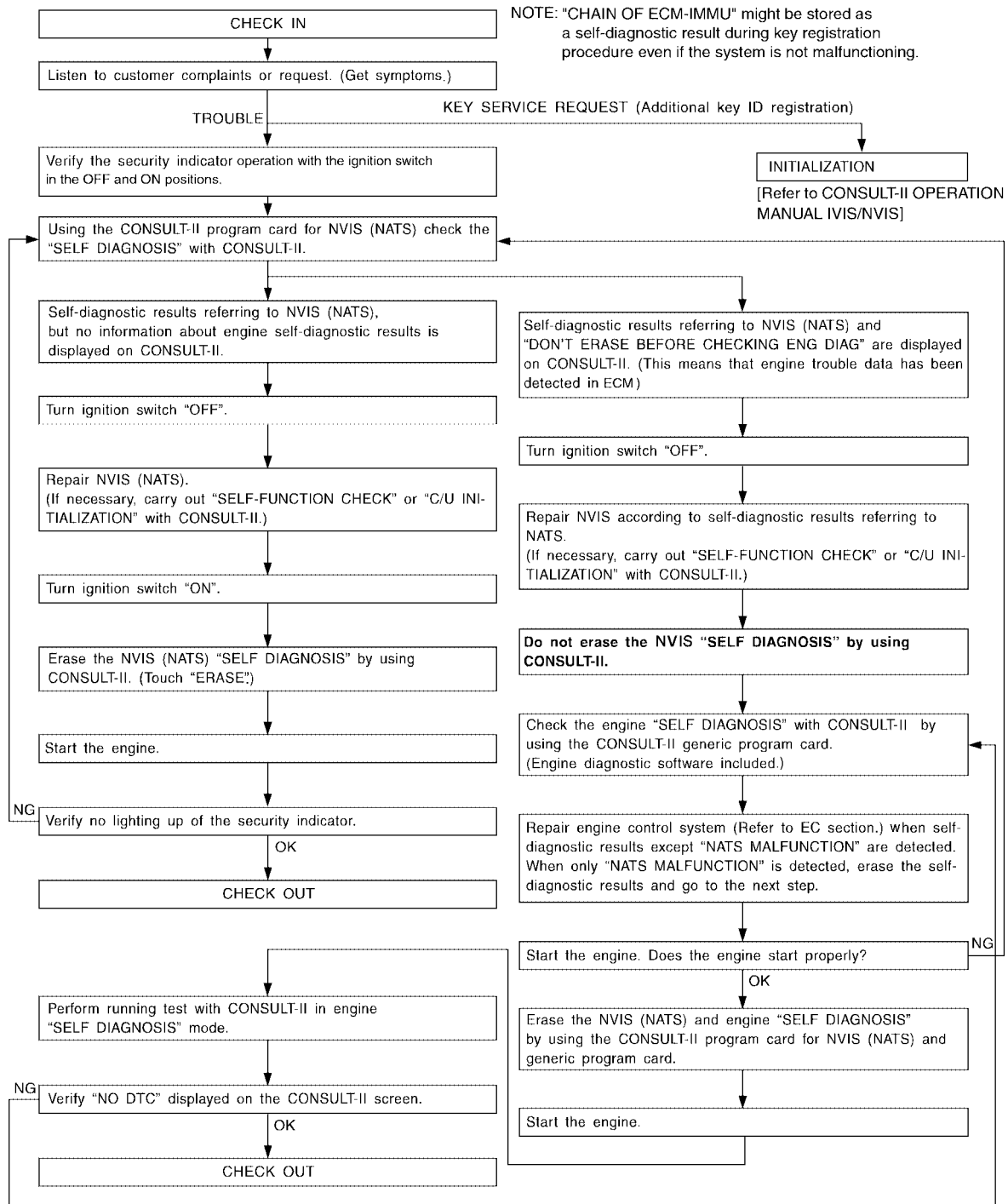

A  
B  
C  
D  
E  
F  
G  
H  
BL  
J  
K  
L  
M

WEL126A

# NVIS (NISSAN VEHICLE IMMOBILIZER SYSTEM — NATS)

## SYMPTOM MATRIX CHART 1 (SELF-DIAGNOSIS RELATED ITEM)

SYMPTOM	Displayed "SELF-DIAG RESULTS" on CONSULT-II screen.	DIAGNOSTIC PROCEDURE (Reference page)	SYSTEM (Malfunctioning part or mode)	REFERENCE PART NO. OF ILLUSTRATION ON NEXT PAGE
	ECM INT CIRC-IMMU	PROCEDURE 1 <a href="#">BL-103</a>	ECM	B
<ul style="list-style-type: none"> <li>● Security indicator lighting up*</li> <li>● Engine hard to start</li> </ul>	CHAIN OF ECM-IMMU	PROCEDURE 2 <a href="#">BL-104</a>	In rare cases, "CHAIN OF ECM-IMMU" might be stored during key registration procedure, even if the system is not malfunctioning.	—
			Open circuit in battery voltage line of IMMU circuit	C1
			Open circuit in ignition line of IMMU circuit	C2
			Open circuit in ground line of IMMU circuit	C3
			Open circuit in communication line between IMMU and ECM	C4
			Short circuit between IMMU and ECM communication line and battery voltage line	C4
			Short circuit between IMMU and ECM communication line and ground line	C4
			ECM	B
	IMMU	A		
	DIFFERENCE OF KEY	PROCEDURE 3 <a href="#">BL-108</a>	Unregistered key	D
			IMMU	A
	CHAIN OF IMMU-KEY	PROCEDURE 4 <a href="#">BL-109</a>	Malfunction of key ID chip	E
			IMMU	A
ID DISCORD, IMM-ECM	PROCEDURE 5 <a href="#">BL-110</a>	System initialization has not yet been completed.	F	
		ECM	F	
LOCK MODE	PROCEDURE 7 <a href="#">BL-113</a>	LOCK MODE	D	
<ul style="list-style-type: none"> <li>● MIL staying ON</li> <li>● Security indicator lighting up*</li> </ul>	DON'T ERASE BEFORE CHECKING ENG DIAG	WORK FLOW <a href="#">BL-101</a>	Engine trouble data and NVIS (NATS) trouble data have been detected in ECM	—

\*: When NVIS (NATS) detects trouble, the security indicator lights up while ignition key is in the "ON" position.

## SYMPTOM MATRIX CHART 2 (NON SELF-DIAGNOSIS RELATED ITEM)

SYMPTOM	DIAGNOSTIC PROCEDURE (Reference page)	SYSTEM (Malfunctioning part or mode)
Security indicator lamp does not light up.	PROCEDURE 6 <a href="#">BL-111</a>	Security indicator lamp
		Open circuit between fuse and IMMU
		Continuation of initialization mode
		IMMU

# NVIS (NISSAN VEHICLE IMMOBILIZER SYSTEM — NATS)

## DIAGNOSTIC SYSTEM DIAGRAM

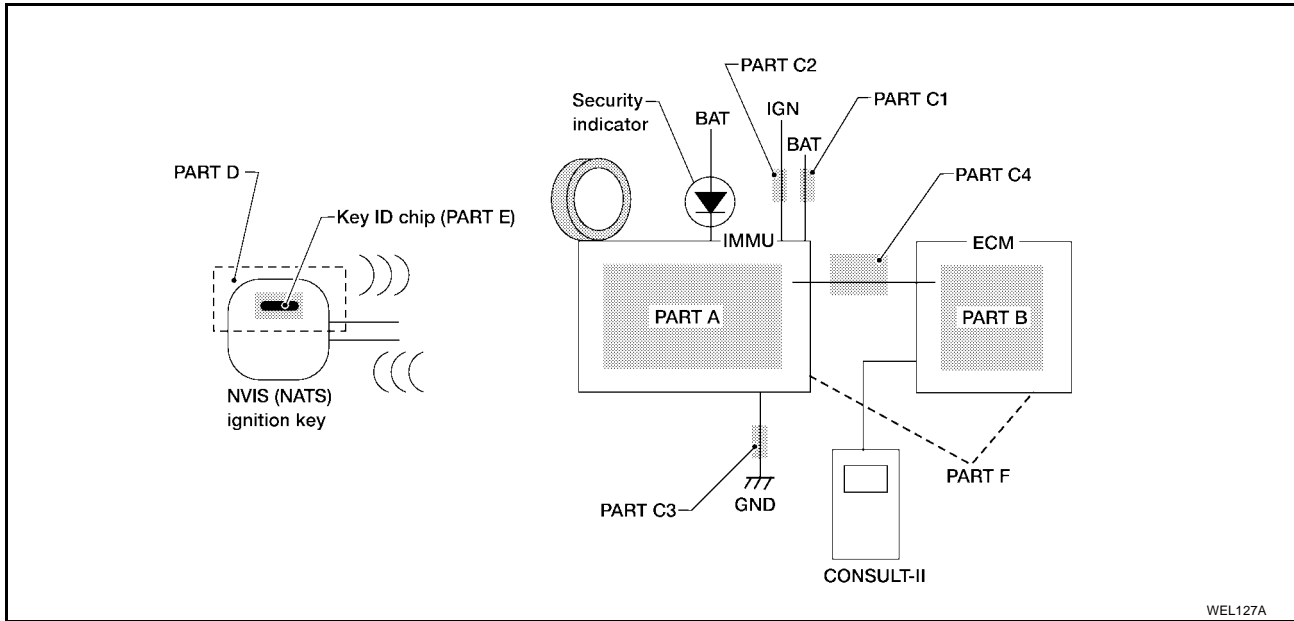

### DIAGNOSTIC PROCEDURE 1

#### Self-diagnostic results:

#### “ECM INT CIRC-IMMU” displayed on CONSULT-II screen

1. Confirm SELF-DIAGNOSTIC RESULTS “ECM INT CIRC-IMMU” displayed on CONSULT-II screen. Ref. part No. B.
2. Replace ECM.
3. Perform initialization with CONSULT-II.  
For initialization, refer to “CONSULT-II OPERATION MANUAL IVIS/NVIS”.

SELF DIAGNOSIS	
DTC RESULTS	TIME
ECM INT CIRC-IMMU	0

SEL314W

# NVIS (NISSAN VEHICLE IMMOBILIZER SYSTEM — NATS)

## DIAGNOSTIC PROCEDURE 2

### Self-diagnostic results:

“CHAIN OF ECM-IMMU” displayed on CONSULT-II screen

## 1. CONFIRM SELF-DIAGNOSTIC RESULTS

Confirm SELF-DIAGNOSTIC RESULTS “CHAIN OF ECM-IMMU” displayed on CONSULT-II screen.

### NOTE:

In rare cases, “CHAIN OF ECM-IMMU” might be stored during key registration procedure, even if the system is not malfunctioning.

Is CONSULT-II screen displayed as shown?

Yes >> GO TO 2.

No >> GO TO [BL-102, "SYMPTOM MATRIX CHART 1 \(SELF-DIAGNOSIS RELATED ITEM\)"](#).

SELF DIAGNOSIS	
DTC RESULTS	TIME
CHAIN OF ECM-IMMU	0

SEL292W

## 2. CHECK POWER SUPPLY CIRCUIT FOR NVIS (NATS) IMMU

1. Disconnect NVIS (NATS) IMMU connector.
2. Check voltage between terminal 8 of NVIS (NATS) IMMU and ground with CONSULT-II or tester.

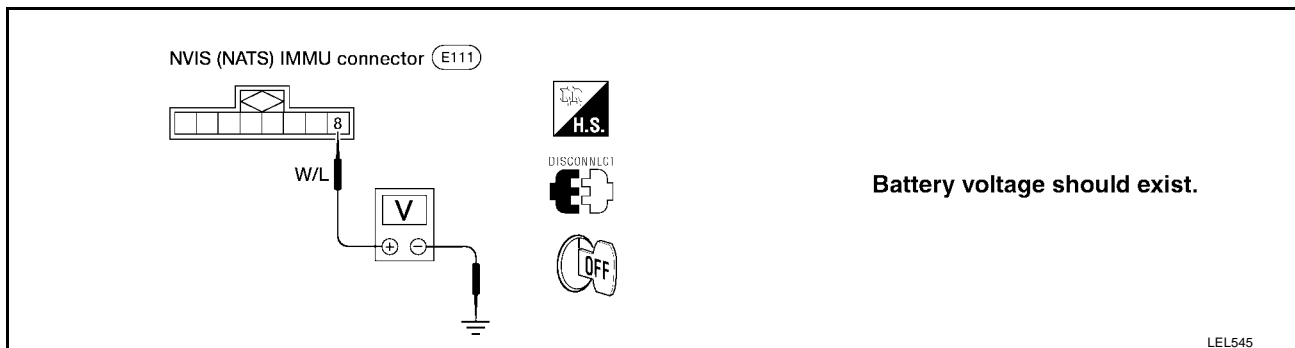

### OK or NG

OK >> GO TO 3.

NG >> Check the following

- 10A fuse (No. 36, located in the fuse and fusible link box)
  - Harness for open or short between fuse and NVIS (NATS) IMMU connector
- Ref. Part No. C1**



# NVIS (NISSAN VEHICLE IMMOBILIZER SYSTEM — NATS)

## 3. CHECK IGN SW. ON SIGNAL

1. Turn ignition switch ON.
2. Check voltage between NVIS (NATS) IMMU harness connector E111 terminal 7 (BR) (QG18DE) or (G/W) (QR25DE) and ground with CONSULT-II or tester.

**Battery voltage should exist.**

OK or NG

OK >> GO TO 4.

NG >> Check the following

- 10A fuse [No. 20, located in the fuse block (J/B)]
  - Harness for open or short between fuse and NVIS (NATS) IMMU connector
- Ref. part No. C2**

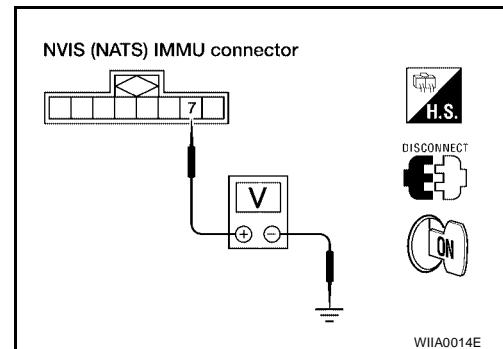

## 4. CHECK GROUND CIRCUIT FOR NVIS (NATS) IMMU

1. Turn ignition switch OFF.
2. Check harness continuity between NVIS (NATS) IMMU terminal 4 and ground.

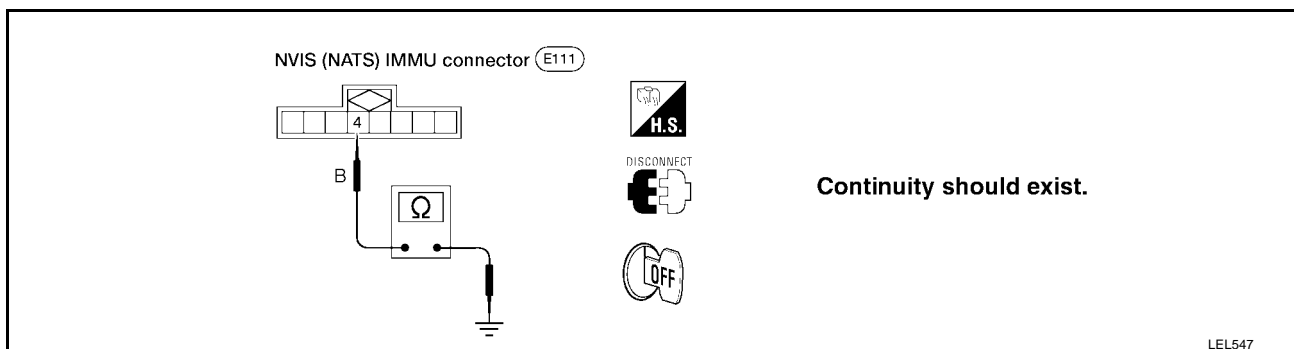

OK or NG

OK >> GO TO 5.

NG >> Repair harness. **Ref. part No. C3**

## 5. CHECK COMMUNICATION LINE OPEN CIRCUIT

1. Disconnect ECM connector.
2. Check harness continuity between ECM harness connector F22 (QG18DE) or F54 (QR25DE) terminal 116 (QG18DE) or 31 (QR25DE) (BR/Y) and NVIS (NATS) IMMU connector E111 terminal 1 (BR/Y).

**Continuity should exist.**

OK or NG

OK >> GO TO 6.

NG >> ● Repair harness or connector.

- **Ref. part No. C4**

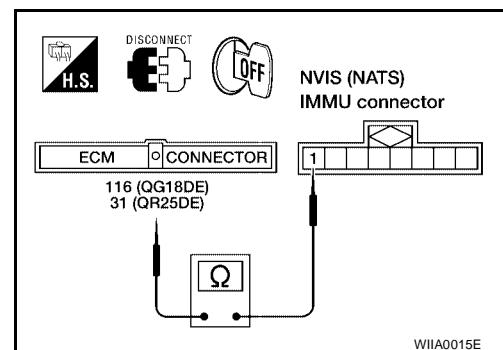

# NVIS (NISSAN VEHICLE IMMOBILIZER SYSTEM — NATS)

## 6. CHECK COMMUNICATION LINE BATTERY SHORT CIRCUIT

1. Turn ignition switch ON.
2. Check voltage between ECM harness connector F22 (QG18DE) or F54 (QR25DE) terminal 116 (QG18DE) or 31 (QR25DE) (BR/Y) or NVIS (NATS) IMMU harness connector E111 terminal 1 (BR/Y) and ground.

**Voltage** : **0V**

OK or NG

OK >> GO TO 7.

NG >> ● Communication line is short-circuited with battery voltage line or ignition switch ON line.

- Repair harness or connectors.
- **Ref. part No. C4**

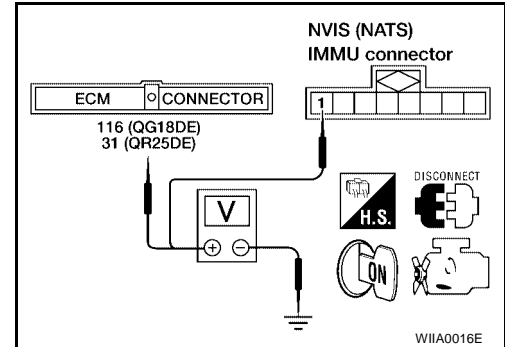

## 7. CHECK COMMUNICATION LINE GROUND SHORT CIRCUIT

1. Turn ignition switch OFF.
2. Check continuity between ECM harness connector F22 (QG18DE) or F54 (QR25DE) terminal 116 (QG18DE) or 31 (QR25DE) (BR/Y) or NVIS (NATS) IMMU connector E111 terminal 1 (BR/Y) and ground.

**Continuity should not exist.**

OK or NG

OK >> GO TO 8.

NG >> ● Communication line is short-circuited with ground line.

- Repair harness or connectors.
- **Ref. part No. C4**

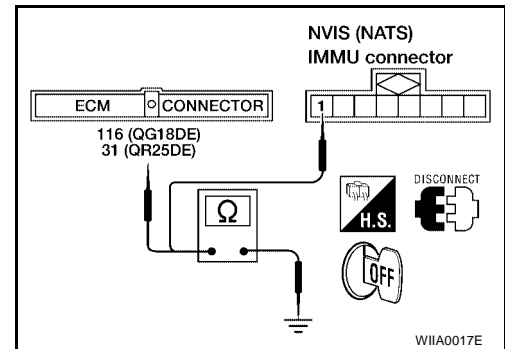

# NVIS (NISSAN VEHICLE IMMOBILIZER SYSTEM — NATS)

## 8. SIGNAL FROM ECM TO NVIS (NATS) IMMU CHECK

1. Check the signal between ECM terminal 116 and ground with CONSULT-II or oscilloscope when ignition switch is turned "ON".
2. Make sure signals which are shown in the figure below can be detected during 750 msec. just after ignition switch is turned "ON".

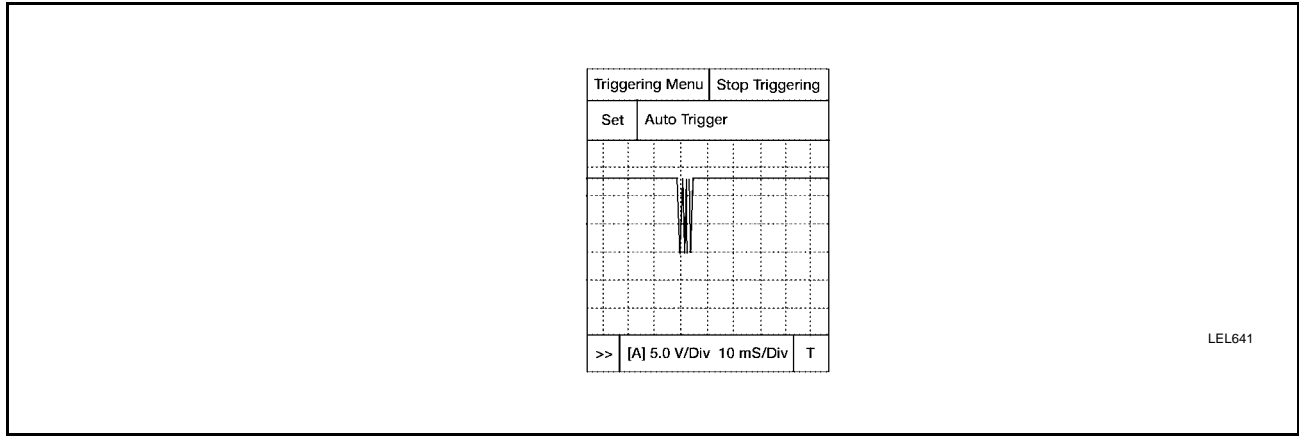

### OK or NG

- OK >>
- NVIS (NATS) IMMU is malfunctioning.
  - Replace NVIS (NATS) IMMU. **Ref. part No. A**
  - Perform initialization with CONSULT-II.
  - For the operation of initialization, refer to "CONSULT-II OPERATION MANUAL IVIS/NVIS".
- NG >>
- ECM is malfunctioning.
  - Replace ECM. **Ref. part No. B**
  - Perform initialization with CONSULT-II.
  - For the operation of initialization, refer to "CONSULT-II OPERATION MANUAL IVIS/NVIS".

# NVIS (NISSAN VEHICLE IMMOBILIZER SYSTEM — NATS)

## DIAGNOSTIC PROCEDURE 3

Self-diagnostic results:

“DIFFERENCE OF KEY” displayed on CONSULT-II screen

### 1. CONFIRM SELF-DIAGNOSTIC RESULTS

Confirm SELF-DIAGNOSTIC RESULTS “DIFFERENCE OF KEY” displayed on CONSULT-II screen.

SELF DIAGNOSIS	
DTC RESULTS	TIME
DIFFERENCE OF KEY	0

SEL293W

Is CONSULT-II screen displayed as above?

Yes >> GO TO 2.

No >> GO TO SYMPTOM MATRIX CHART 1.

### 2. PERFORM INITIALIZATION WITH CONSULT-II

Perform initialization with CONSULT-II. Re-register all NVIS (NATS) ignition key IDs.

For initialization, refer to “CONSULT-II OPERATION MANUAL IVIS/NVIS”.

IMMU INITIALIZATION
INITIALIZATION FAIL
THEN IGN KEY SW 'OFF' AND 'ON', AFTER CONFIRMING SELF-DIAG AND PASSWORD, PERFORM C/U INITIALIZATION AGAIN.

SEL297W

#### NOTE:

If the initialization is not completed or fails, CONSULT-II shows above message on the screen.

Can the system be initialized?

Yes >> ● Start engine. (END)

- (Ignition key ID was unregistered. **Ref. part No. D**)

No >> ● NVIS (NATS) IMMU is malfunctioning.

- Replace NVIS (NATS) IMMU. **Ref. part No. A**

- Perform initialization with CONSULT-II.

- For initialization, refer to “CONSULT-II OPERATION MANUAL IVIS/NVIS”.

# NVIS (NISSAN VEHICLE IMMOBILIZER SYSTEM — NATS)

## DIAGNOSTIC PROCEDURE 4

Self-diagnostic results:  
"CHAIN OF IMMU-KEY" displayed on CONSULT-II screen

### 1. CONFIRM SELF-DIAGNOSTIC RESULTS

Confirm SELF-DIAGNOSTIC RESULTS "CHAIN OF IMMU-KEY" displayed on CONSULT-II screen.

SELF DIAGNOSIS	
DTC RESULTS	TIME
CHAIN OF IMMU-KEY	0

SEL294W

Is CONSULT-II screen displayed as above?

Yes >> GO TO 2.

No >> GO TO [BL-102, "SYMPTOM MATRIX CHART 1 \(SELF-DIAGNOSIS RELATED ITEM\)"](#) .

### 2. CHECK NVIS (NATS) IGNITION KEY ID CHIP

Start engine with another registered NVIS (NATS) ignition key.

Does the engine start?

Yes >> ● Ignition key ID chip is malfunctioning.

● Replace the ignition key.

● **Ref. part No. E**

● Perform initialization with CONSULT-II.

● For initialization, refer to "CONSULT-II OPERATION MANUAL IVIS/NVIS".

No >> GO TO 3.

### 3. CHECK NVIS (NATS) IMMU INSTALLATION

Check NVIS (NATS) IMMU installation.

Refer to [BL-114, "How to Replace NVIS \(NATS\) IMMU"](#) .

OK or NG

OK >> ● NVIS (NATS) IMMU is malfunctioning.

● Replace NVIS (NATS) IMMU. **Ref. part No. A**

● Perform initialization with CONSULT-II.

● For initialization, refer to "CONSULT-II OPERATION MANUAL IVIS/NVIS".

NG >> Reinstall NVIS (NATS) IMMU correctly.

# NVIS (NISSAN VEHICLE IMMOBILIZER SYSTEM — NATS)

## DIAGNOSTIC PROCEDURE 5

### Self-diagnostic results:

“ID DISCORD, IMM-ECM” displayed on CONSULT-II screen

## 1. CONFIRM SELF-DIAGNOSTIC RESULTS

Confirm SELF-DIAGNOSTIC RESULTS “ID DISCORD, IMM-ECM” displayed on CONSULT-II screen.

SELF DIAGNOSIS	
DTC RESULTS	TIME
ID DISCORD, IMM-ECM	0

SEL298W

### NOTE:

“ID DISCORD IMM-ECM”:

Registered ID of NVIS (NATS) IMMU is in discord with that of ECM.

Is CONSULT-II screen displayed as above?

Yes >> GO TO 2.

No >> GO TO [BL-102, "SYMPTOM MATRIX CHART 1 \(SELF-DIAGNOSIS RELATED ITEM\)"](#).

## 2. PERFORM INITIALIZATION WITH CONSULT-II

Perform initialization with CONSULT-II. Re-register all NVIS (NATS) ignition key IDs.

For initialization, refer to “CONSULT-II OPERATION MANUAL IVIS/NVIS”.

IMMU INITIALIZATION
INITIALIZATION FAIL
THEN IGN KEY SW 'OFF' AND 'ON', AFTER CONFIRMING SELF-DIAG AND PASSWORD, PERFORM C/U INITIALIZATION AGAIN.

SEL297W

### NOTE:

If the initialization is not completed or fails, CONSULT-II shows above message on the screen.

Can the system be initialized?

Yes >> ● Start engine. (END)

- (System initialization had not been completed. **Ref. part No. F**)

No >> ● ECM is malfunctioning.

- Replace ECM. **Ref. part No. F**
- Perform initialization with CONSULT-II.
- For initialization, refer to “CONSULT-II OPERATION MANUAL IVIS/NVIS”.

# NVIS (NISSAN VEHICLE IMMOBILIZER SYSTEM — NATS)

## DIAGNOSTIC PROCEDURE 6

### “SECURITY INDICATOR LAMP DOES NOT LIGHT UP”

#### 1. CHECK FUSE

Check 10A fuse [No. 12, located in the fuse block (J/B)].

Is 10A fuse OK?

- Yes >> GO TO 2.
- No >> Replace fuse.

#### 2. CHECK SECURITY INDICATOR LAMP

1. Install 10A fuse.
2. Perform initialization with CONSULT-II.  
For initialization, refer to “CONSULT-II OPERATION MANUAL IVIS/NVIS”.
3. Turn ignition switch OFF.
4. Start engine and turn ignition switch OFF.
5. Check the security indicator lamp lighting.

**Security indicator lamp should light up.**

OK or NG

- OK >> INSPECTION END
- NG >> GO TO 3.

#### 3. CHECK SECURITY INDICATOR LAMP POWER SUPPLY CIRCUIT

1. Disconnect security indicator lamp connector.
2. Check voltage between security indicator lamp connector terminal 1 and ground.

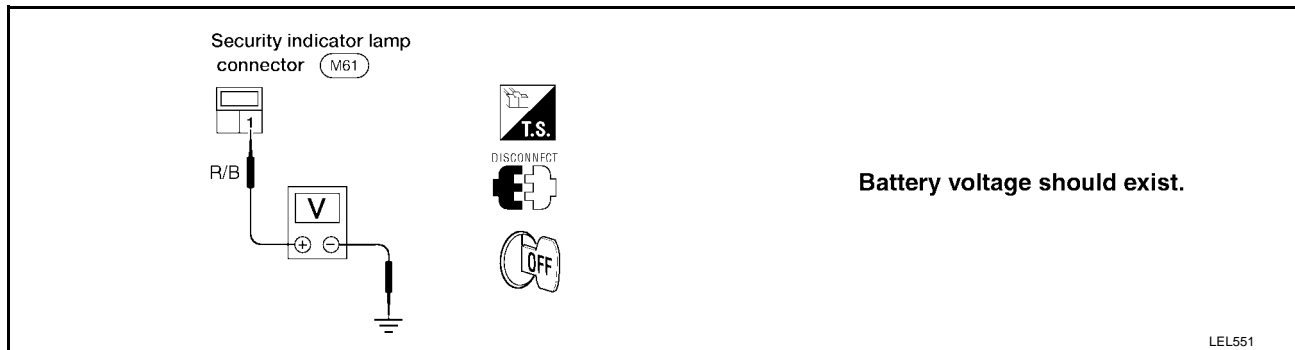

OK or NG

- OK >> GO TO 4.
- NG >> Check harness for open or short between fuse and security indicator lamp.

#### 4. CHECK SECURITY INDICATOR LAMP

Check security indicator lamp.

Is security indicator lamp OK?

- Yes >> GO TO 5.
- No >> Replace security indicator lamp.

## NVIS (NISSAN VEHICLE IMMOBILIZER SYSTEM — NATS)

### 5. CHECK NVIS (NATS) IMMU FUNCTION

1. Connect NVIS (NATS) IMMU connector.
2. Disconnect security indicator lamp connector.
3. Check continuity between NVIS (NATS) IMMU terminal 5 and ground.

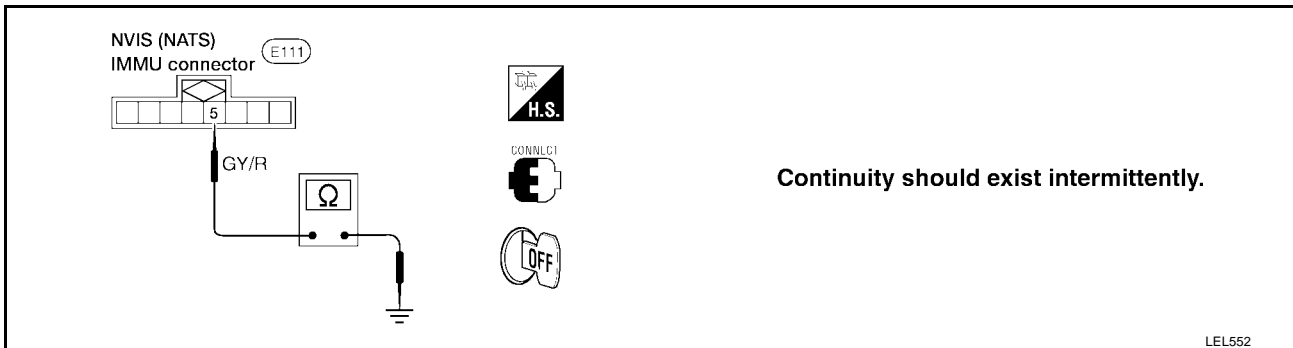

#### OK or NG

- OK >> Check harness for open or short between security indicator lamp and NVIS (NATS) IMMU.
- NG >> ● NVIS (NATS) IMMU is malfunctioning.
- Replace NVIS (NATS) IMMU.
  - Perform initialization with CONSULT-II.
  - For initialization, refer to "CONSULT-II OPERATION MANUAL IVIS/NVIS".



# NVIS (NISSAN VEHICLE IMMOBILIZER SYSTEM — NATS)

## DIAGNOSTIC PROCEDURE 7

Self-diagnostic results:

“LOCK MODE” displayed on CONSULT-II screen

### 1. CONFIRM SELF-DIAGNOSTIC RESULTS

Confirm SELF-DIAGNOSTIC RESULTS “LOCK MODE” is displayed on CONSULT-II screen.

SELF DIAGNOSIS	
DTC RESULTS	TIME
LOCK MODE	0

SEL295W

Is CONSULT-II screen displayed as above?

Yes >> GO TO 2.

No >> GO TO [BL-102, "SYMPTOM MATRIX CHART 1 \(SELF-DIAGNOSIS RELATED ITEM\)"](#) .

### 2. ESCAPE FROM LOCK MODE

1. Turn ignition switch OFF.
2. Turn ignition switch ON with registered key. (Do not start engine.) Wait 5 seconds.
3. Return the key to OFF position.
4. Repeat steps 2 and 3 twice (total of three cycles).
5. Start the engine.

Does engine start?

Yes >> ● System is OK.

- (Now system is escaped from “LOCK MODE”.)

No >> GO TO 3.

### 3. CHECK NVIS (NATS) IMMU INSTALLATION

Check NVIS (NATS) IMMU installation. Refer to [BL-114, "How to Replace NVIS \(NATS\) IMMU"](#) .

OK or NG

OK >> GO TO 4.

NG >> Reinstall NVIS (NATS) IMMU correctly.

# NVIS (NISSAN VEHICLE IMMOBILIZER SYSTEM — NATS)

## 4. PERFORM INITIALIZATION WITH CONSULT-II

Perform initialization with CONSULT-II.

For initialization, refer to "CONSULT-II OPERATION MANUAL IVIS/NVIS".



### NOTE:

If the initialization is not completed or fails, CONSULT-II shows the above message on the screen.

Can the system be initialized?

Yes >> System is OK.

No >> Check "CHAIN OF IMMU-KEY". Refer to [BL-109, "DIAGNOSTIC PROCEDURE 4"](#).

## How to Replace NVIS (NATS) IMMU

EIS0015S

### NOTE:

- If NVIS (NATS) IMMU is not installed correctly, NVIS (NATS) system will not operate properly and SELF-DIAG RESULTS on CONSULT-II screen will show "LOCK MODE" or "CHAIN OF IMMU-KEY".

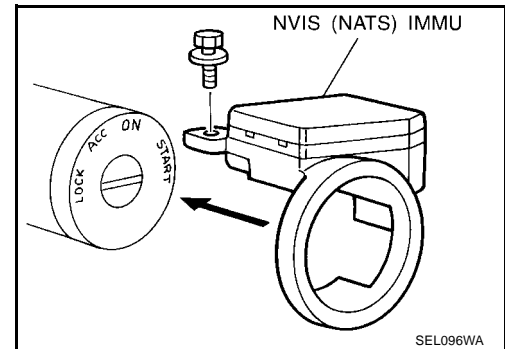

# BODY (ALIGNMENT)

PFP:74312

## BODY (ALIGNMENT)

EIS0015T

### Alignment

- All dimensions indicated in figures are actual ones.
- When using a tracking gauge, adjust both pointers to equal length. Then check the pointers and gauge itself to make sure there is no free play.
- When a measuring tape is used, check to be sure there is no elongation, twisting or bending.
- Measurements should be taken at the center of the mounting holes.
- An asterisk (\*) indicates the measuring point value is the same on both sides.
- The coordinates of the measurement points are the distances measured from the standard line of "X", "Y" and "Z".

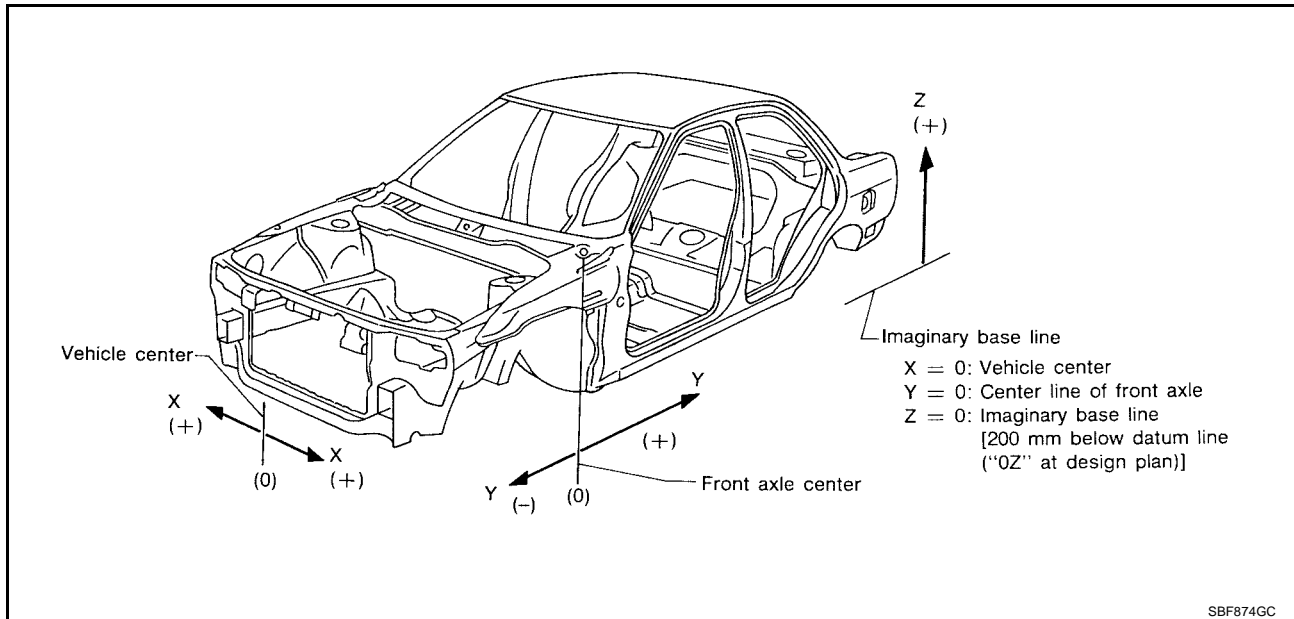

A  
B  
C  
D  
E  
F  
G  
H  
BL  
J  
K  
L  
M

# BODY (ALIGNMENT)

## ENGINE COMPARTMENT

### Measurement

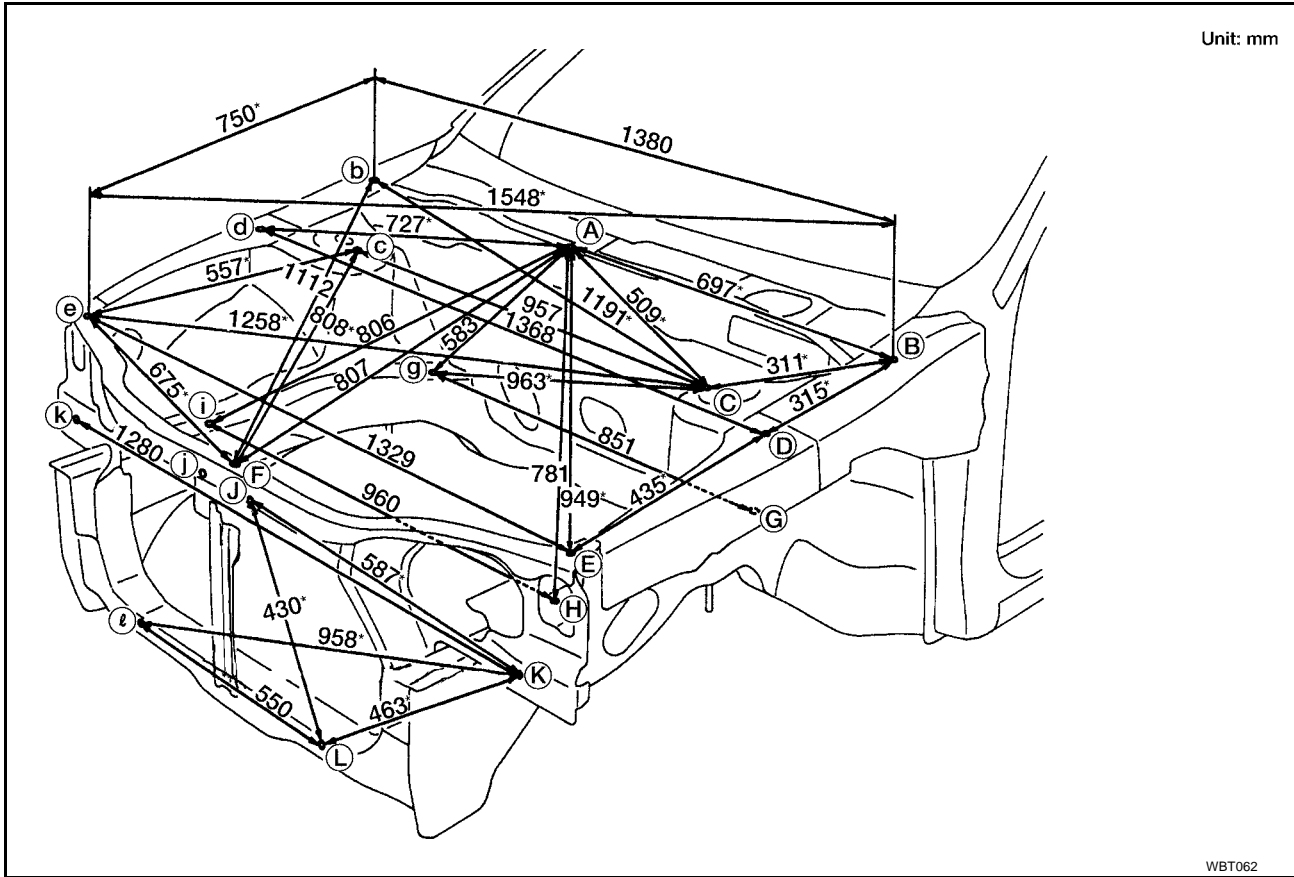

# BODY (ALIGNMENT)

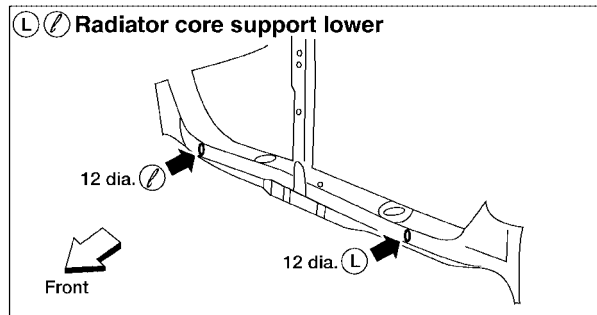
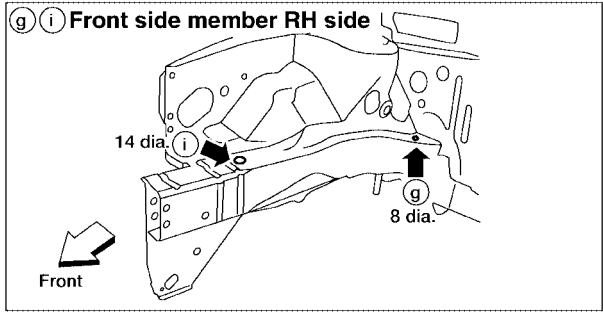
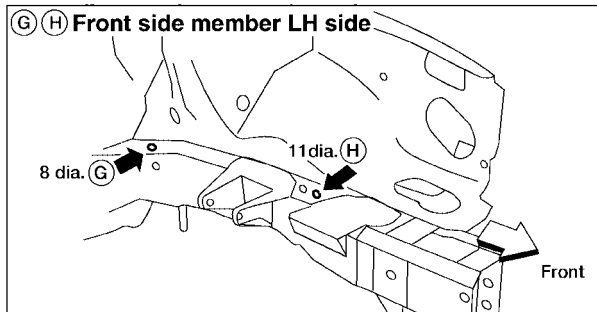
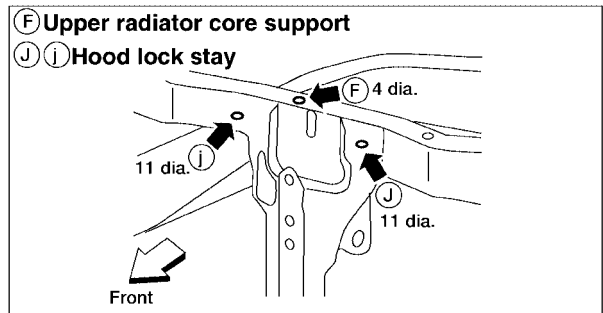
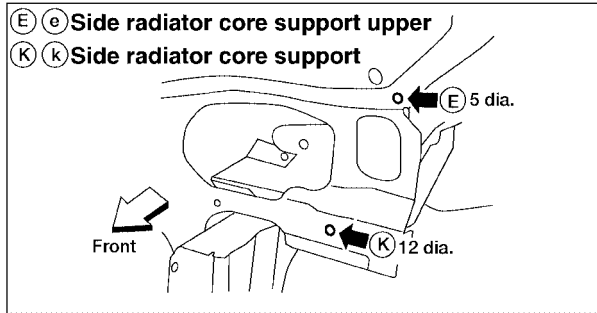
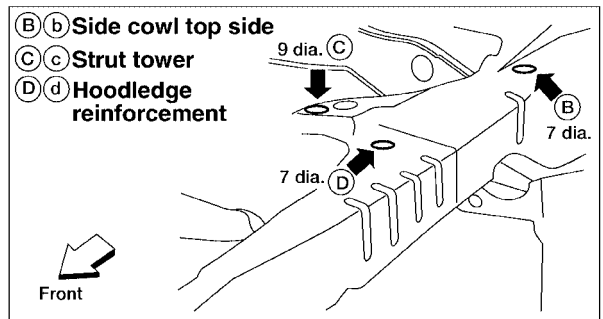
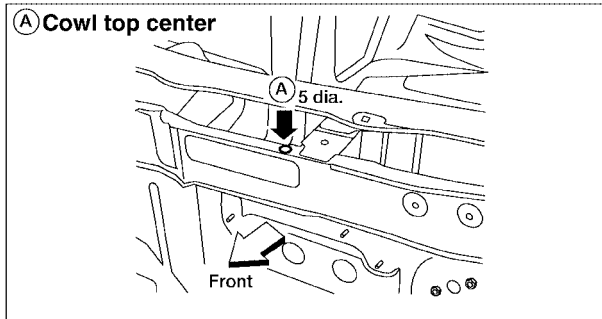

Unit: mm

A  
B  
C  
D  
E  
F  
G  
H  
J  
K  
L  
M

BL

WBT071

# BODY (ALIGNMENT)

## Measurement Points

As viewed from underside.

\* Figures marked with an \* indicates symmetrically identical dimensions on both right- and left-hand sides of the vehicle.

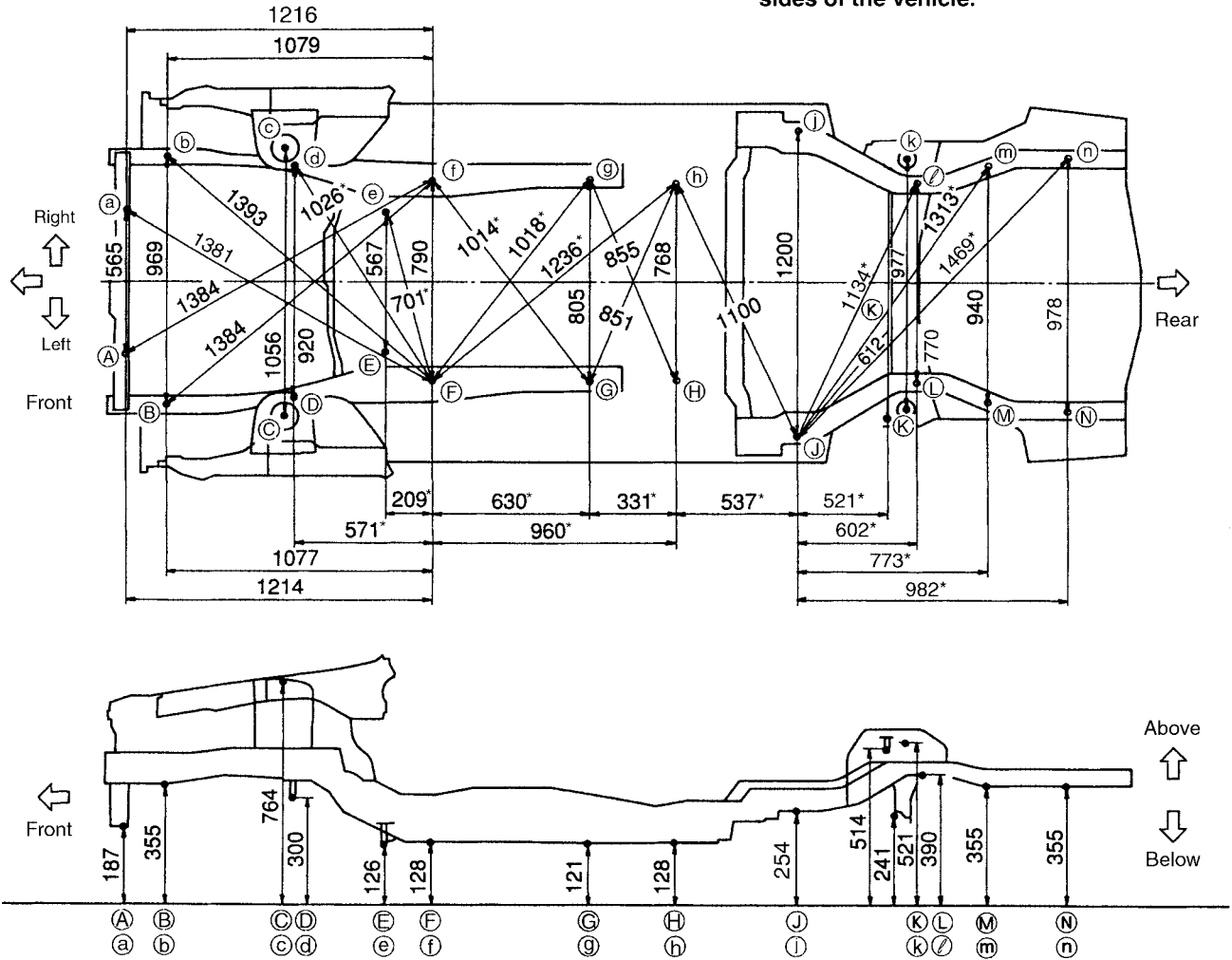

WBT063

# BODY (ALIGNMENT)

## UNDERBODY Measurement

As viewed from underside.

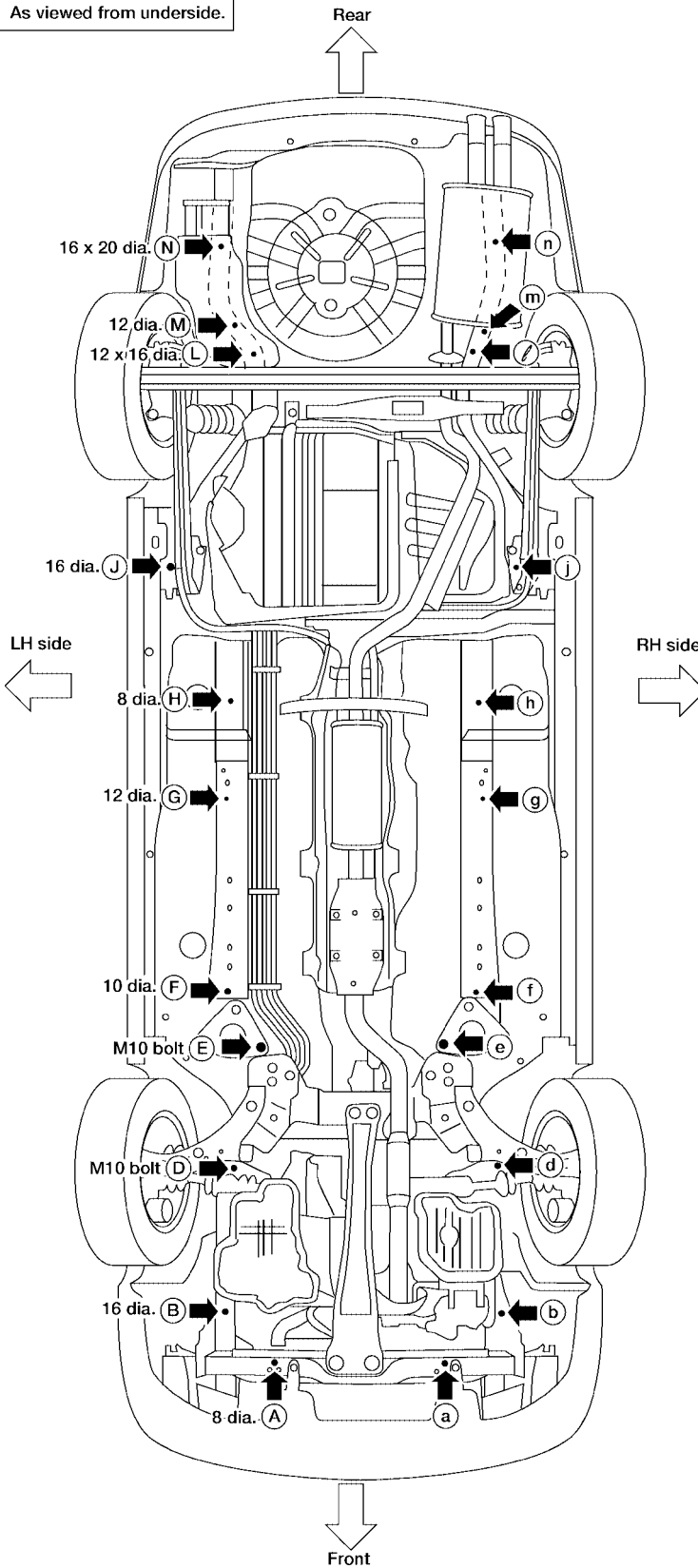

Unit: mm

Coordinates:

(A), (a)	(M), (m)
X: 280, -285	X: 470
Y: 607, -609	Y: 2790
Z: 186.8	Z: 355
(B), (b)	(N), (n)
X: 477, -492	X: 489
Y: -450	Y: 3016
Z: 355	Z: 355
(C), (c)	
X: 528	
Y: 18	
Z: 764	
(D), (d)	
X: 460	
Y: 60	
Z: 300.3	
(E), (e)	
X: 283.5	
Y: 423	
Z: 126.5	
(F), (f)	
X: 395	
Y: 600	
Z: 127.8	
(G), (g)	
X: 400, -405	
Y: 1230	
Z: 120.6	
(H), (h)	
X: 384	
Y: 1560	
Z: 128	
(J), (j)	
X: 600	
Y: 2035	
Z: 254	
(K), (k)	
X: 488.3	
Y: 2467.8	
Z: 520.6	
(L), (l)	
X: 385	
Y: 2580	
Z: 390	

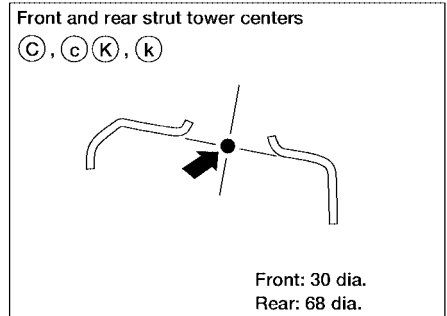

WBT064

## BODY (ALIGNMENT)

---