

# SECTION **STC**

## STEERING CONTROL SYSTEM

A  
B  
C  
D  
E  
F  
G  
**STC**  
H  
I  
J  
K  
L  
M  
N  
O  
P

### CONTENTS

<p style="text-align: center;"><b>EPS</b></p> <p><b>SERVICE INFORMATION</b> ..... 2</p> <p><b>PRECAUTIONS</b> ..... 2</p> <p style="padding-left: 20px;">Precaution for Supplemental Restraint System (SRS) "AIR BAG" and "SEAT BELT PRE-TENSIONER" ..... 2</p> <p style="padding-left: 20px;">Precaution Necessary for Steering Wheel Rotation After Battery Disconnect ..... 2</p> <p style="padding-left: 20px;">Service Notice or Precaution for EPS System ..... 3</p> <p><b>EPS SYSTEM</b> ..... 4</p> <p style="padding-left: 20px;">System Description ..... 4</p> <p style="padding-left: 20px;">Schematic ..... 5</p> <p style="padding-left: 20px;">CAN Communication ..... 5</p> <p><b>TROUBLE DIAGNOSIS</b> ..... 6</p> <p style="padding-left: 20px;">Fail-Safe Function ..... 6</p> <p style="padding-left: 20px;">How to Perform Trouble Diagnosis ..... 6</p> <p style="padding-left: 20px;">Component Parts Location ..... 7</p> <p style="padding-left: 20px;">Wiring Diagram - EPS - ..... 8</p>	<p style="padding-left: 20px;">EPS Control Unit Input/Output Signal Reference Value ..... 9</p> <p style="padding-left: 20px;">CONSULT-III Function (EPS) ..... 11</p> <p style="padding-left: 20px;">Symptom Chart ..... 12</p> <p><b>TROUBLE DIAGNOSIS FOR SYSTEM</b> ..... 14</p> <p style="padding-left: 20px;">DTC C1601 BATTERY VOLT ..... 14</p> <p style="padding-left: 20px;">DTC C1604 TORQUE SENSOR ..... 15</p> <p style="padding-left: 20px;">DTC C1605 ANGLE SENSOR ..... 16</p> <p style="padding-left: 20px;">DTC C1606 EPS MOTOR ..... 16</p> <p style="padding-left: 20px;">DTC C1608 CONTROL UNIT ..... 16</p> <p style="padding-left: 20px;">DTC U1000 CAN COMM CIRCUIT ..... 17</p> <p style="padding-left: 20px;">DTC U1200 CAN VHCL SPEED ABS ..... 17</p> <p><b>TROUBLE DIAGNOSIS FOR SYMPTOMS</b> ..... 18</p> <p style="padding-left: 20px;">EPS Warning Lamp Does Not Turn ON ..... 18</p> <p style="padding-left: 20px;">EPS Warning Lamp Does Not Turn OFF ..... 18</p> <p style="padding-left: 20px;">Steering Wheel Turning Force Is Heavy or Light .... 19</p> <p style="padding-left: 20px;">Unbalance Steering Wheel Turning Force and Return Between Right and Left ..... 20</p> <p style="padding-left: 20px;">Unbalance Steering Wheel Turning Force (Torque Variation) ..... 21</p>
--	---

## SERVICE INFORMATION

### PRECAUTIONS

#### Precaution for Supplemental Restraint System (SRS) "AIR BAG" and "SEAT BELT PRE-TENSIONER"

INFOID:000000006148993

The Supplemental Restraint System such as "AIR BAG" and "SEAT BELT PRE-TENSIONER", used along with a front seat belt, helps to reduce the risk or severity of injury to the driver and front passenger for certain types of collision. This system includes seat belt switch inputs and dual stage front air bag modules. The SRS system uses the seat belt switches to determine the front air bag deployment, and may only deploy one front air bag, depending on the severity of a collision and whether the front occupants are belted or unbelted. Information necessary to service the system safely is included in the SRS and SB section of this Service Manual.

#### **WARNING:**

- To avoid rendering the SRS inoperative, which could increase the risk of personal injury or death in the event of a collision which would result in air bag inflation, all maintenance must be performed by an authorized NISSAN/INFINITI dealer.
- Improper maintenance, including incorrect removal and installation of the SRS can lead to personal injury caused by unintentional activation of the system. For removal of Spiral Cable and Air Bag Module, see the SRS section.
- Do not use electrical test equipment on any circuit related to the SRS unless instructed to in this Service Manual. SRS wiring harnesses can be identified by yellow and/or orange harnesses or harness connectors.

#### PRECAUTIONS WHEN USING POWER TOOLS (AIR OR ELECTRIC) AND HAMMERS

#### **WARNING:**

- When working near the Airbag Diagnosis Sensor Unit or other Airbag System sensors with the Ignition ON or engine running, DO NOT use air or electric power tools or strike near the sensor(s) with a hammer. Heavy vibration could activate the sensor(s) and deploy the air bag(s), possibly causing serious injury.
- When using air or electric power tools or hammers, always switch the Ignition OFF, disconnect the battery, and wait at least 3 minutes before performing any service.

#### Precaution Necessary for Steering Wheel Rotation After Battery Disconnect

INFOID:000000006148994

#### **NOTE:**

- This Procedure is applied only to models with Intelligent Key system and NVIS/IVIS (NISSAN/INFINITI VEHICLE IMMOBILIZER SYSTEM - NATS).
- Remove and install all control units after disconnecting both battery cables with the ignition knob in the "LOCK" position.
- Always use CONSULT-III to perform self-diagnosis as a part of each function inspection after finishing work. If DTC is detected, perform trouble diagnosis according to self-diagnostic results.

For models equipped with the Intelligent Key system and NVIS/IVIS, an electrically controlled steering lock mechanism is adopted on the key cylinder.

For this reason, if the battery is disconnected or if the battery is discharged, the steering wheel will lock and steering wheel rotation will become impossible.

If steering wheel rotation is required when battery power is interrupted, follow the procedure below before starting the repair operation.

#### OPERATION PROCEDURE

1. Connect both battery cables.

#### **NOTE:**

Supply power using jumper cables if battery is discharged.

2. Use the Intelligent Key or mechanical key to turn the ignition switch to the "ACC" position. At this time, the steering lock will be released.
3. Disconnect both battery cables. The steering lock will remain released and the steering wheel can be rotated.
4. Perform the necessary repair operation.

# PRECAUTIONS

[EPS]

## < SERVICE INFORMATION >

- When the repair work is completed, return the ignition switch to the "LOCK" position before connecting the battery cables. (At this time, the steering lock mechanism will engage.)
- Perform a self-diagnosis check of all control units using CONSULT-III.

## Service Notice or Precaution for EPS System

INFOID:000000006148995

### CAUTION:

Check or confirm the following item when performing the trouble diagnosis.

- Check any possible causes by interviewing the symptom and it's condition from the customer if any malfunction, such as EPS warning lamp turns ON, occurs.
- Check if air pressure and size of tires are proper, the specified part is used for the steering wheel, and control unit is genuine part.
- Check if the connection of steering column assembly and steering gear assembly is proper (there is not looseness of mounting bolts, damage of rods, boots or sealants, and leakage of grease, etc).
- Check if the wheel alignment is adjusted properly.
- Check if there is any damage or modification to suspension or body resulting in increased weight or altered ground clearance.
- Check if installation conditions of each link and suspension are proper.
- Check if the battery voltage is proper
- Check connection conditions of each connector are proper.
- Before connecting or disconnecting the EPS control unit harness connector, turn ignition switch "OFF" and disconnect battery ground cable. Because battery voltage is applied to EPS control unit even if ignition switch is turned "OFF".

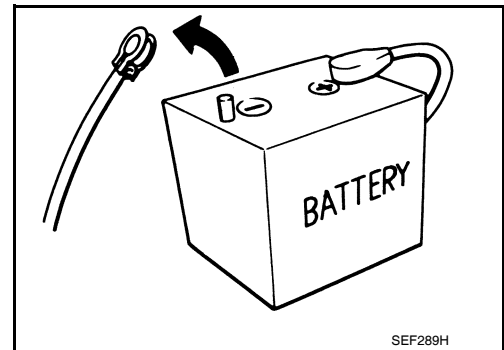

- When connecting or disconnecting pin connectors into or from EPS control unit, take care not to damage pin terminals (bend or break).  
When connecting pin connectors, make sure that there are no bends or breaks on EPS control unit pin terminal.

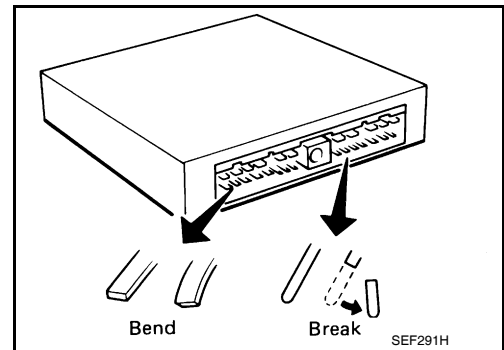

- Before replacing EPS control unit, perform EPS control unit input/output signal inspection and make sure whether EPS control unit functions properly or not. Refer to [STC-9, "EPS Control Unit Input/Output Signal Reference Value"](#).

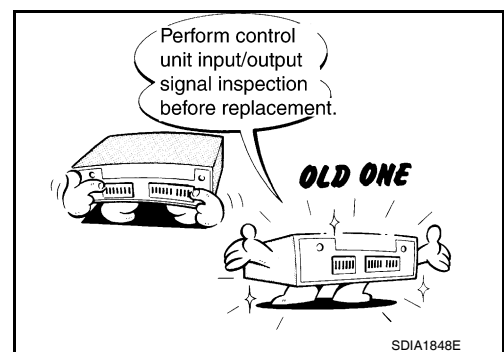

## EPS SYSTEM

### System Description

INFOID:000000006148996

#### EPS CONTROL UNIT

- EPS control unit performs an arithmetical operation on data, such as steering wheel turning force (sensor signal) from the torque sensor, vehicle speed signal, etc. Then it generates an optimum assist torque to the EPS motor according to the driving condition.
- EPS control unit decreases the output to EPS motor while extremely using the power steering function (e.g., full steering) for protecting EPS motor and EPS control unit (Protect overload status). While activating protect overload status, the assist torque gradually decreases, and the steering wheel turning force becomes heavy. The normal assist torque reactivates by not steering.
- In case of an error in the electrical system, the fail-safe function stops output signals to the EPS motor. Then the previous state is changed to the manual steering state.
- Self-diagnosis can be done with CONSULT-III.

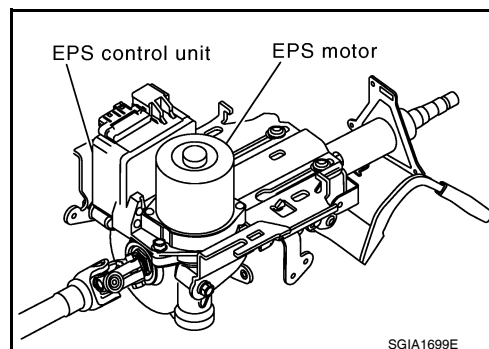

#### EPS MOTOR

EPS motor provides the assist torque by control signal from EPS control unit.

#### TORQUE SENSOR

Torque sensor detects the steering torque, and transmit the signal to EPS control unit.

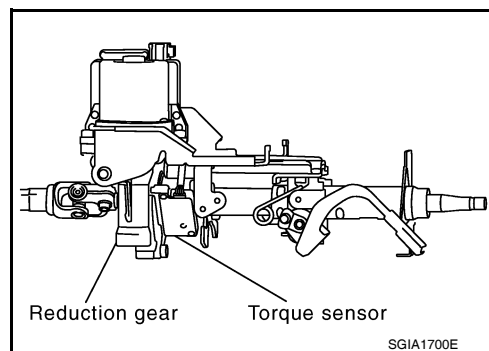

#### REDUCTION GEAR

Reduction gear increases the assist torque provided from EPS motor with worm gears, and outputs to the column shaft.

#### EPS WARNING LAMP

Turns ON when there is a malfunction in EPS system. It indicates that fail-safe mode is engaged and enters a manual steering state (Control turning force steering wheel becomes heavy). Also turns ON when ignition switch is turned ON, for purpose of lamp check. Turns OFF after the engine starts if system is normal.

#### EPS Warning Lamp Indication

Condition	EPS warning lamp
Lamp check	Turns ON when ignition switch is turned ON. Turns OFF after engine start.
EPS system malfunction	ON
Other than above (system normal)	OFF

# EPS SYSTEM

< SERVICE INFORMATION >

[EPS]

## Schematic

INFOID:000000006148997

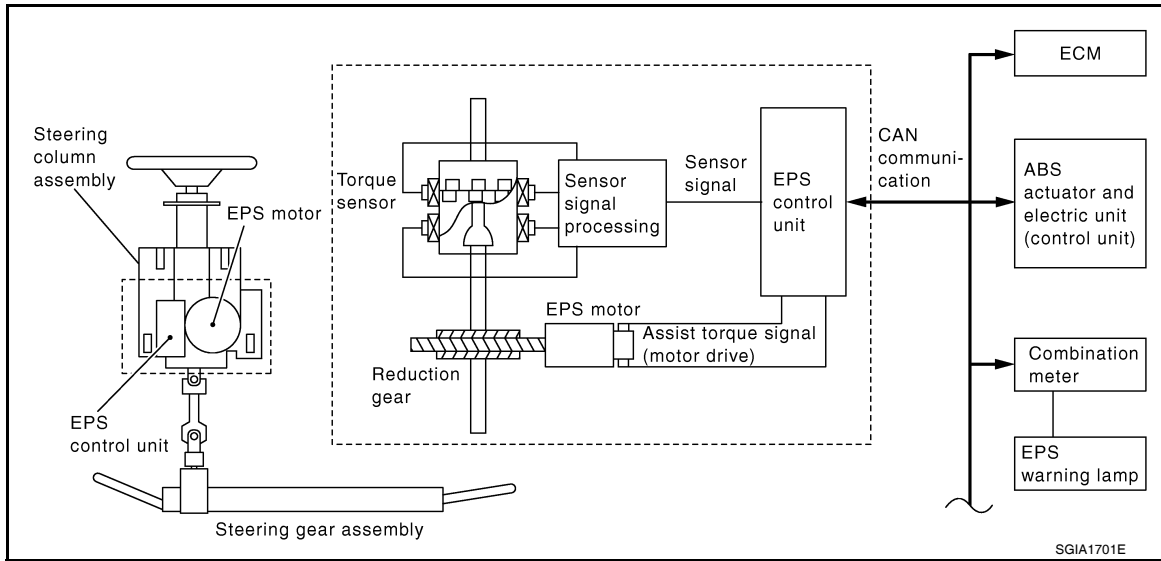

## COMPONENTS FUNCTION DESCRIPTION

STC

Component parts	Function
EPS control unit (Electric power steering control unit)	<ul style="list-style-type: none"> <li>Outputs optimum assist torque signal to EPS motor.</li> <li>Reduces output signals to EPS motor and protects EPS motor and EPS control unit when using power steering continuously and excessively.</li> <li>As a fail-safe function, turned off output signal to EPS motor and then enters a manual steering state, if malfunction is detected in EPS system.</li> <li>Self-diagnosis can be clone with CONSULT-III.</li> </ul>
EPS motor	Products assist torque by control signal from EPS control unit.
Torque sensor	Detects steering wheel turning force and outputs sensor signal to EPS control unit.
Reduction gear	Increases motor-produced assist torque by worm gear and transmits it to column shaft.
EPS warning lamp	Combination meter illuminates lamp if malfunction is detected in electrical system of EPS system.
ECM	Transmits the following signals via CAN communication to EPS control unit. <ul style="list-style-type: none"> <li>Engine status signal</li> </ul>
ABS actuator and electric unit (control unit) (With ABS)	Transmits the following signals via CAN communication to EPS control unit. <ul style="list-style-type: none"> <li>Vehicle speed signal</li> </ul>

## CAN Communication

INFOID:000000006148998

## SYSTEM DESCRIPTION

Refer to [LAN-7. "System Description"](#).

## TROUBLE DIAGNOSIS

### Fail-Safe Function

INFOID:000000006148999

- If any malfunction occurs in the system, and control unit detects the malfunction, EPS warning lamp in the combination meter turns ON to indicate system malfunction.
- When EPS warning lamp is ON, enters a manual steering state. (Control turning force steering wheel becomes heavy.)

### How to Perform Trouble Diagnosis

INFOID:000000006149000

#### BASIC CONCEPT

- To perform trouble diagnosis, it is the must to have understanding about vehicle systems (control and mechanism) thoroughly.
- It is also important to clarify customer complaints before starting the inspection.

First of all, reproduce the symptoms, and understand them fully. Ask customer about his/her complaints carefully. In some cases, it will be necessary to check symptoms by driving vehicle with customer.

**CAUTION:**

**Customers are not professionals. It is dangerous to make an easy guess like “maybe the customer means that...” or “maybe the customer mentions this symptom”.**

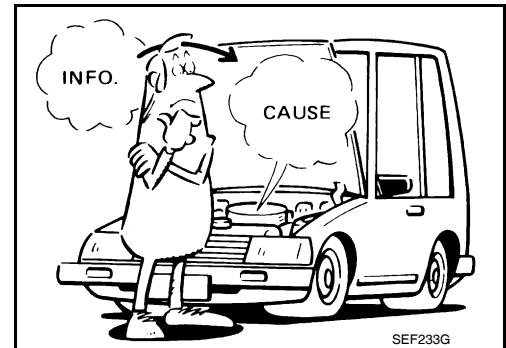

- It is essential to check symptoms right from the beginning in order to repair malfunctions completely.

For intermittent malfunctions, reproduce symptoms based on interview with customer and past examples. Do not perform inspection on ad hoc basis. Most intermittent malfunctions are caused by poor contacts. In this case, it will be effective to shake suspected harness or connector by hand. When repairing without any symptom diagnosis, you cannot judge if malfunctions has actually been eliminated.

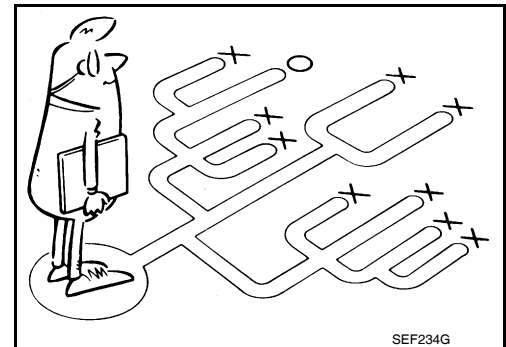

#### PRECAUTIONS FOR TROUBLE DIAGNOSIS

- Be sure to check the procedures of the trouble diagnosis in advance. Refer to "How to Perform Trouble Diagnosis".
- Always erase memory after completing trouble diagnosis.
- Checking continuity and voltage between units, be sure to check connector terminals for disconnection, looseness, bend, or collapse. Repair or replace applicable part if any non-standard condition is detected.
- Be careful not to forcibly extend any connector terminal if a circuit tester is used for the check.
- Always confirm the general precautions. Refer to [G1-3, "General Precaution"](#).

#### INTERVIEW

- Complaints vary depending on the person. It is important to clarify the customer's actual remarks.
- Ask the customer about what symptoms occur under what conditions. Use the information to reproduce the symptom of confirm by vehicle.

#### KEY POINTS

**WHAT** ..... Vehicle & engine model  
**WHEN** ..... Date, Frequencies  
**WHERE**..... Road conditions  
**HOW** ..... Operating conditions,  
 Weather conditions,  
 Symptoms

SEF907L

# TROUBLE DIAGNOSIS

< SERVICE INFORMATION >

[EPS]

## Component Parts Location

INFOID:000000006149001

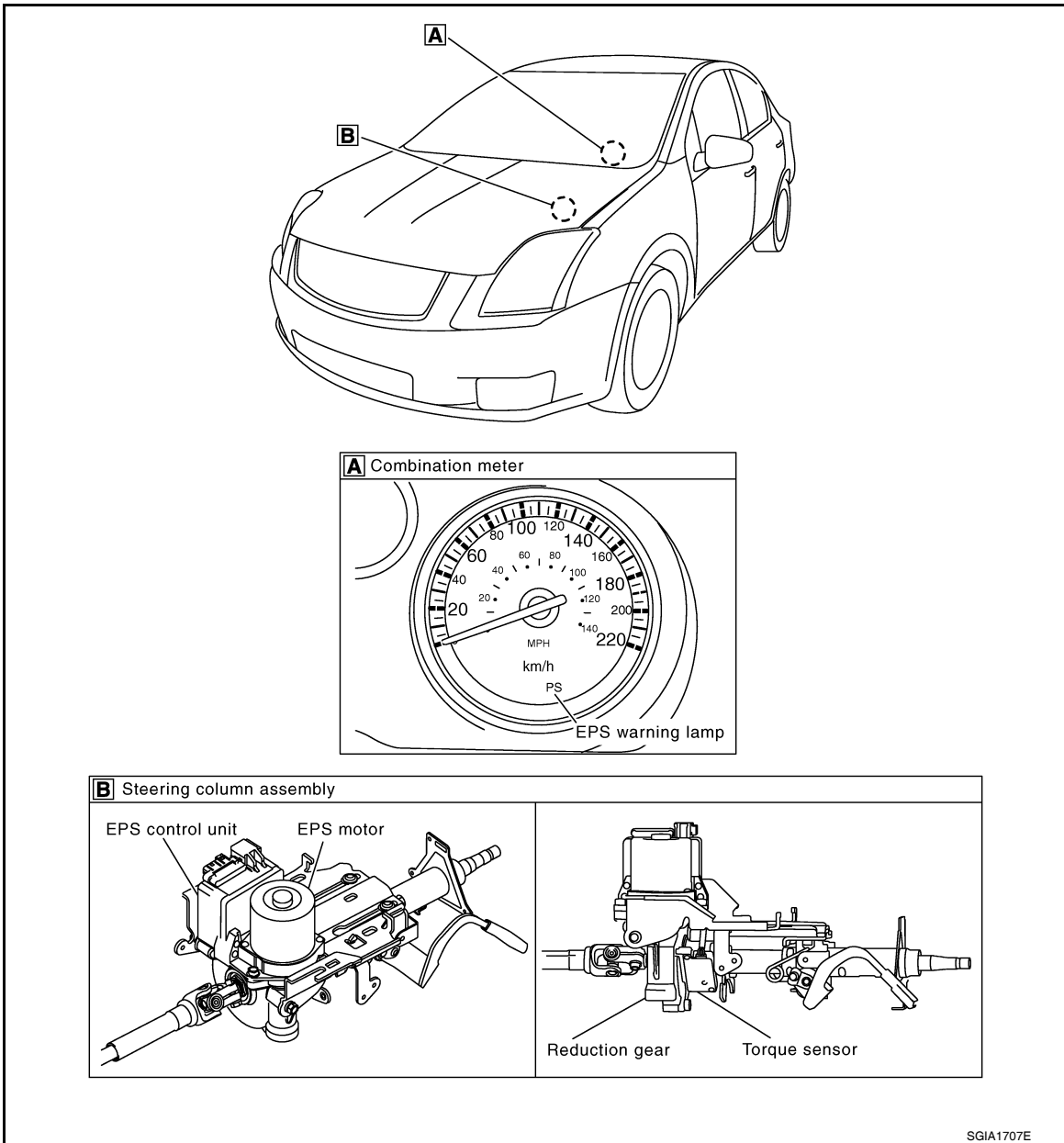

A  
B  
C  
D  
E  
F  
STC  
H  
I  
J  
K  
L  
M  
N  
O  
P

# TROUBLE DIAGNOSIS

< SERVICE INFORMATION >

[EPS]

## Wiring Diagram - EPS -

INFOID:000000006149002

### STC-EPS-01

▬ : DATA LINE

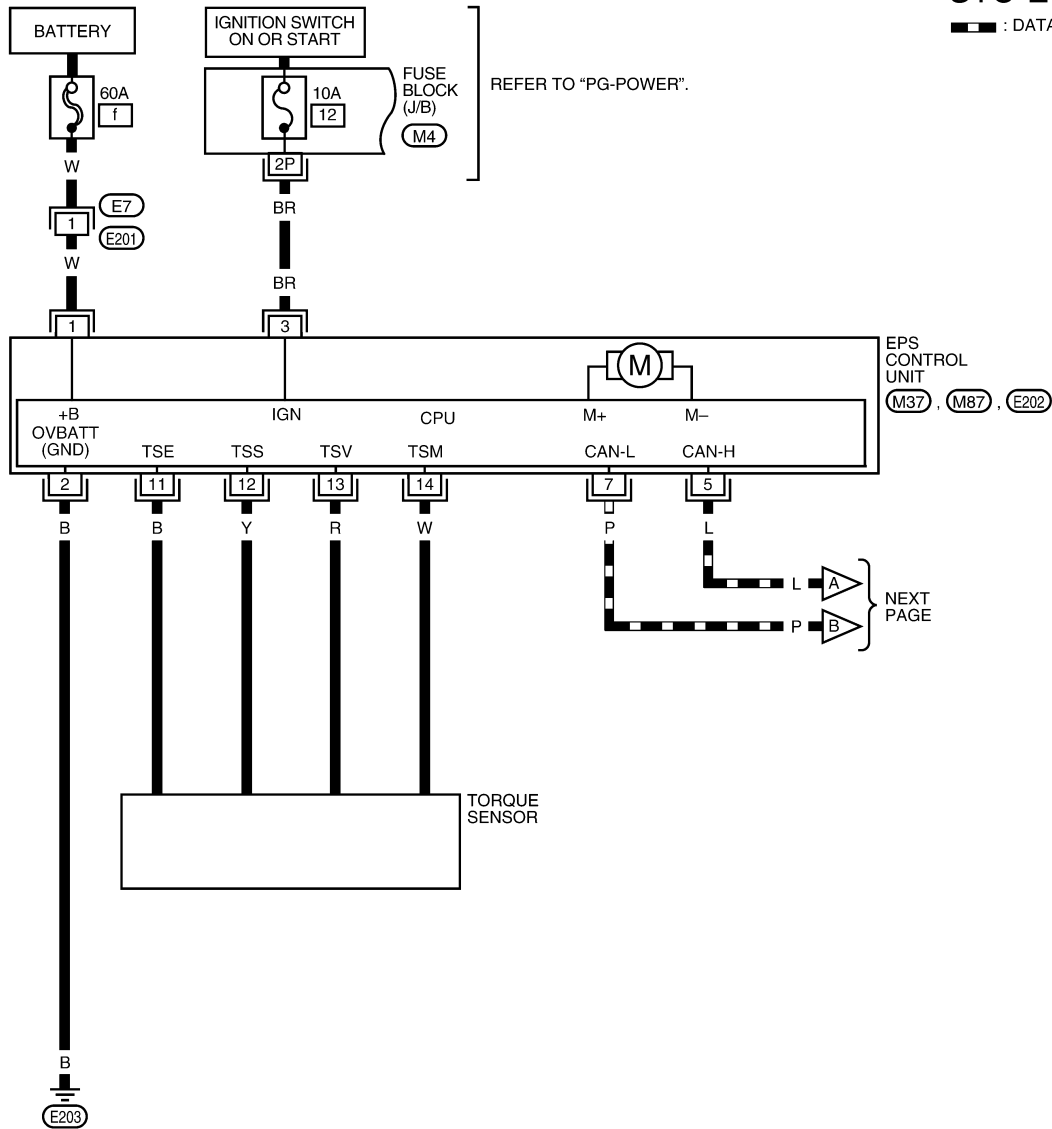

\* : THIS CONNECTOR IS NOT SHOWN IN "HARNESS LAYOUT" OF PG SECTION.

ABGWA0020GB



# TROUBLE DIAGNOSIS

< SERVICE INFORMATION >

[EPS]

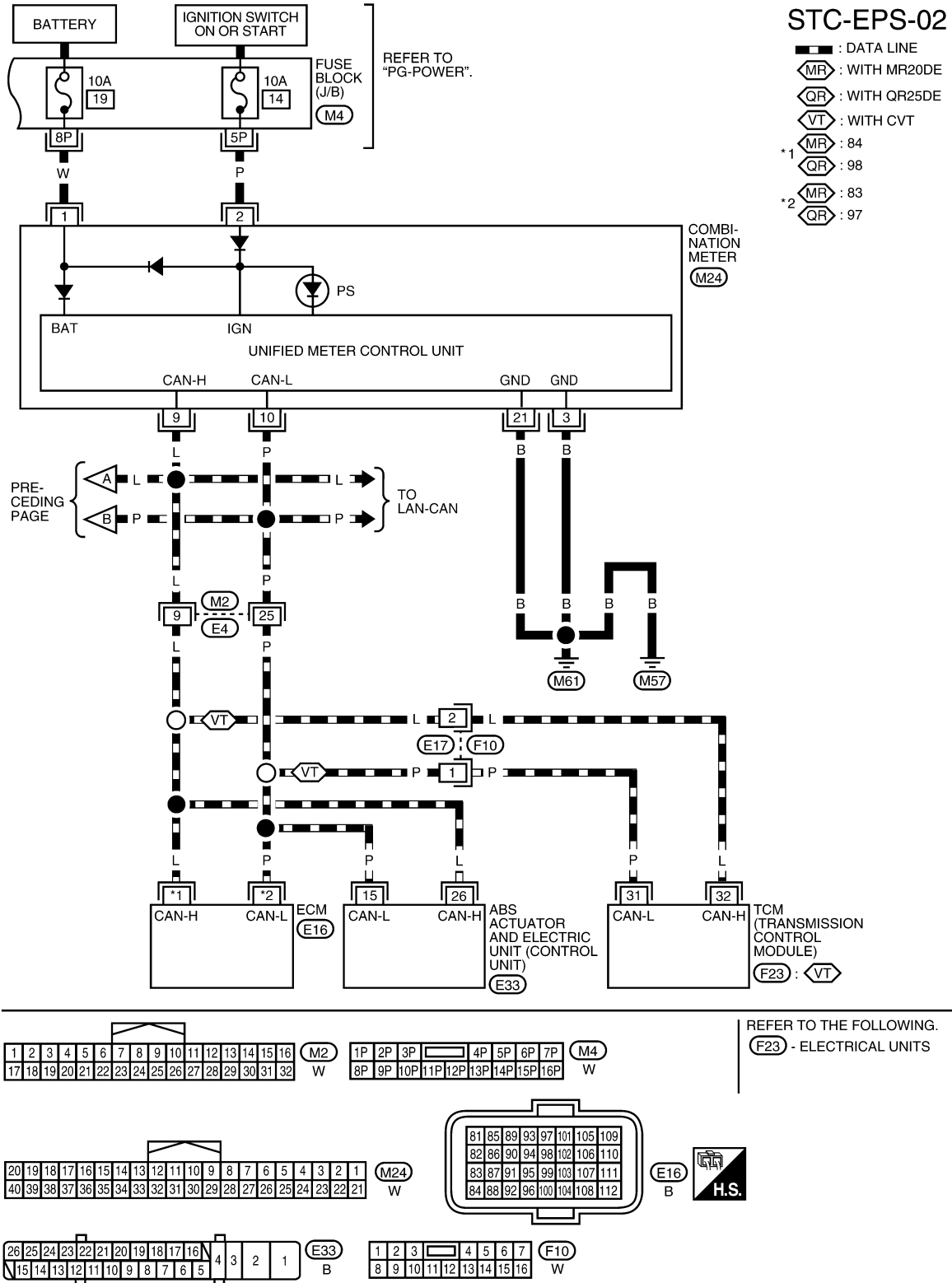

A  
B  
C  
D  
E  
F  
H  
I  
J  
K  
L  
M  
N  
O  
P

STC

## EPS Control Unit Input/Output Signal Reference Value

INFOID:000000006149003

### SPECIFICATIONS WITH CONSULT-III

**CAUTION:**

The output signal indicates the EPS control unit calculation date. The normal values will be displayed even in the event that the output circuit (harness) is open.

# TROUBLE DIAGNOSIS

< SERVICE INFORMATION >

[EPS]

Monitor item (Unit)	Content	Condition		Display value
BATTERY VOLT (V)	Power supply voltage for EPS control unit	Ignition switch: ON		Battery voltage
TORQUE SENSOR (Nm)	Steering wheel turning force	Engine running	Steering wheel: Not steering (There is no steering force)	0.00 Nm
			Steering wheel: Steering	0 – 8.19 Nm <sup>*1</sup> (The value is changed according to steering left or right)
MOTOR SIG (A)	Command current to EPS motor	Engine running	Steering wheel: Not steering (There is no steering force)	0.00 A
			Steering wheel: Steering	0 – 84 A (The value is changed according to steering left or right)
C/U TEMP (°)	EPS control unit temperature	Ignition switch: ON		Temperature in control unit
ASSIST LEVEL (%)	Assist available level	Engine running	Steering wheel: Normal steering	100%
			Steering wheel: Excessive steering	Gradually-decreased from 100% <sup>*3</sup>
VEHICLE SPEED (km/h) or (mph)	Vehicle speed	Vehicle stopped		0 km/h (0 mph)
		While driving		Approximately equal to the indication on speedometer (Inside of ±10%) <sup>*2</sup>
WARNING LAMP (ON/OFF)	EPS warning lamp condition	EPS warning lamp: ON		ON
		EPS warning lamp: OFF		OFF
ENGINE STATUS (RUN/CRANK/STALL/STOP)	Engine status	Engine stopped		STOP
		Engine stalled		STALL
		Engine cranking		CRANK
		Engine running		RUN

\*1: In the front of the value, "L" is displayed at steering left and "R" is displayed at steering right.

\*2: It is not a malfunction, though it might not be corresponding just after ignition switch is turned ON.

\*3: It turns to 100% after waiting for a short period of time.

## EPS HARNESS CONNECTOR TERMINAL LAYOUT

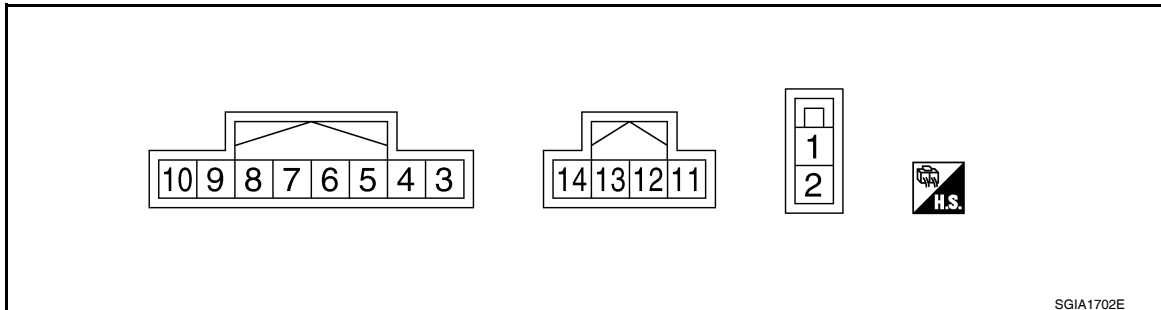

## TERMINALS AND REFERENCE VALUES FOR EPS CONTROL UNIT

Data are reference value and are measured.

Terminal	Wire color	Item	Condition	Data (Approx.)
1	W	Power supply (Memory back-up)	Ignition switch: ON	Battery voltage
			Ignition switch: OFF	Battery voltage
2	B	Ground	Always	0 V

# TROUBLE DIAGNOSIS

[EPS]

## < SERVICE INFORMATION >

Terminal	Wire color	Item	Condition	Data (Approx.)	
3	BR	Power supply	Ignition switch: ON	Battery voltage	
			Ignition switch: OFF	0 V	
5	L	CAN-H	—	—	
7	P	CAN-L	—	—	
11	B	Torque sensor ground	Always	0 V	
12	Y	Torque sensor sub	Engine running	Steering wheel: Not steering (There is no steering force)	2.5 V
				Steering wheel: Steering	1.7 V – 3.3 V (The value is changed according to steering left or right)
13	R	Torque sensor power supply	Ignition switch: ON	8 V	
			Ignition switch: OFF	0 V	
14	W	Torque sensor main	Engine running	Steering wheel: Not steering (There in no steering force)	2.5 V
				Steering wheel: Steering	1.7 V – 3.3 V (The value is changed according to steering left or right)

**CAUTION:**

When using a circuit tester to measure voltage for inspection, be sure not to extend forcibly any connector terminals.

## CONSULT-III Function (EPS)

INFOID:000000006149004

### FUNCTION

CONSULT-III can display each diagnostic item using the diagnostic test modes shown following.

Diagnostic test mode	Function
Self Diagnostic Result	• Self-diagnostic results can be read and erased quickly.
Data Monitor	• Input/Output data in the EPS control unit can be read.
CAN diagnostic support monitor	• The results of transmit/receive diagnosis of CAN communication can be read.
ECU Identification	• EPS control unit part number can be read.

## SELF-DIAG RESULTS MODE

### Display Item List

Item (CONSULT-III screen terms)	Diagnostic item is detected when....	Check item
BATTERY VOLT [C1601]	When the power supply malfunction supplied to EPS control unit is detected.	<a href="#">STC-14, "DTC C1601 BATTERY VOLT"</a>
TORQUE SENSOR [C1604]	When the torque sensor malfunction assembled in steering column assembly is detected.	<a href="#">STC-15, "DTC C1604 TORQUE SENSOR"</a>
ANGLE SENSOR [C1605]	When the motor rotor position sensor malfunction of EPS control unit is detected.	<a href="#">STC-16, "DTC C1605 ANGLE SENSOR"</a>
EPS MOTOR [C1606]	When the motor driver malfunction of EPS control unit or EPS motor malfunction is detected.	<a href="#">STC-16, "DTC C1606 EPS MOTOR"</a>
CONTROL UNIT [C1608]	When the internal malfunction is detected in EPS control unit.	<a href="#">STC-16, "DTC C1608 CONTROL UNIT"</a>
CAN COMM CIRCUIT [U1000]	When EPS control unit is not transmitting or receiving CAN communication signal 2 seconds or more.	<a href="#">STC-17, "DTC U1000 CAN COMM CIRCUIT"</a>

# TROUBLE DIAGNOSIS

[EPS]

## < SERVICE INFORMATION >

Item (CONSULT-III screen terms)	Diagnostic item is detected when....	Check item
CAN VHCL SPEED ABS [U1200]	When the malfunction is detected in vehicle speed signal received with CAN communication.	<a href="#">STC-17. "DTC U1200 CAN VHCL SPEED ABS"</a>
NO DTC IS DETECTED. FURTHER TESTING MAY BE REQUIRED.	No NG item has been detected.	—

**CAUTION:**

If “CAN COMM CIRCUIT [U1000]” is displayed with other DTCs, first perform the trouble diagnosis for CAN communication line.

## DATA MONITOR

### Display Item List

Monitor item (Unit)	Remarks
BATTERY VOLT (V)	Power supply voltage for EPS control unit is displayed
TORQUE SENSOR (Nm)	Steering wheel turning force detected by torque sensor is displayed
MOTOR SIG (A)	Current commanded value to EPS motor is displayed
C/U TEMP (°)	EPS control unit temperature is displayed
ASSIST LEVEL (%)	EPS control unit assist available level is displayed
VEHICLE SPEED (km/h) or (mph)	Vehicle speed is displayed from vehicle speed signal with CAN communication
MOTOR CURRENT (A)	Display the current value consumed by EPS motor
WARNING LAMP (ON/OFF)	EPS warning lamp control status is displayed
ENGINE STATUS (RUN/CRANK/STALL/STOP)	Engine speed is displayed from engine status signal with CAN communication

## Symptom Chart

INFOID:000000006149005

If EPS warning lamp turns ON, perform self-diagnosis. Refer to [STC-11. "CONSULT-III Function \(EPS\)"](#).

Symptom	Condition	Check item	Reference page
EPS warning lamp does not turn ON when ignition switch to “ON”. (EPS warning lamp check)	Ignition switch: ON	CAN communication line	<a href="#">STC-18</a>
		Combination meter	
EPS warning lamp does not turn OFF for several seconds after starting the engine	Engine running	CAN communication line	<a href="#">STC-18</a>
		Power supply and ground for EPS control unit	
		Torque sensor	
		EPS motor	
		Vehicle speed signal	
		Engine status signal	
		Combination meter	
Steering wheel turning force is heavy or light, while driving	<ul style="list-style-type: none"> <li>• While driving</li> <li>• Steering wheel turning</li> </ul>	CAN communication line	<a href="#">STC-19</a>
		Vehicle speed signal	
		Engine status signal	
		EPS motor	
Unbalance steering wheel turning force and return between right and left, while driving	<ul style="list-style-type: none"> <li>• While driving</li> <li>• Steering wheel turning</li> </ul>	Wheel alignment	<a href="#">STC-20</a>
		Steering wheel turning force (Mechanical malfunction)	

# TROUBLE DIAGNOSIS

< SERVICE INFORMATION >

[EPS]

Symptom	Condition	Check item	Reference page
Unbalance steering wheel turning force, while driving (Torque variation)	<ul style="list-style-type: none"> <li>• While driving</li> <li>• Steering wheel turning</li> </ul>	Steering column intermediate shaft installation condition	<a href="#">STC-21</a>
		Steering wheel turning force (Mechanical malfunction)	

A  
B  
C  
D  
E  
F  
  
H  
I  
J  
K  
L  
M  
N  
O  
P

STC

# TROUBLE DIAGNOSIS FOR SYSTEM

[EPS]

< SERVICE INFORMATION >

## TROUBLE DIAGNOSIS FOR SYSTEM

### DTC C1601 BATTERY VOLT

INFOID:000000006149006

#### CONSULT-III REFERENCE VALUE IN DATA MONITOR MODE

Data are reference value.

Monitor item (Unit)	Content	Condition	Display value
BATTERY VOLT (V)	Power supply voltage for EPS control unit	Ignition switch: ON	Battery voltage

#### TERMINALS AND REFERENCE VALUES FOR EPS CONTROL UNIT

Refer to [STC-9. "EPS Control Unit Input/Output Signal Reference Value"](#).

#### DIAGNOSTIC PROCEDURE

##### 1. CHECK EPS CONTROL UNIT POWER SUPPLY CIRCUIT

1. Turn ignition switch "OFF".
2. Disconnect EPS control unit harness connector.
3. Turn ignition switch "ON". (Do not start engine.)
4. Check voltage between EPS control unit harness connector (A) terminals and ground.

Connector	Terminal	Voltage
M37	3 – Ground	Battery voltage
E202	1 – Ground	Battery voltage

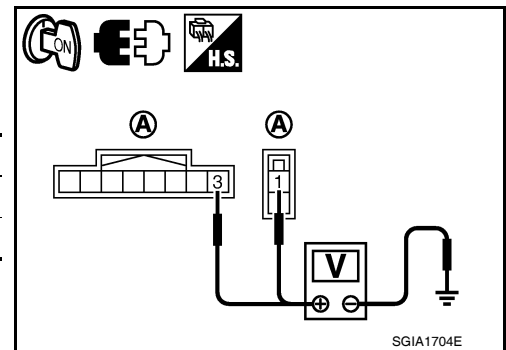

5. Turn ignition switch "OFF".
6. Check voltage between EPS control unit harness connector (A) terminals and ground.

Connector	Terminal	Voltage
M37	3 – Ground	Approx. 0 V
E202	1 – Ground	Battery voltage

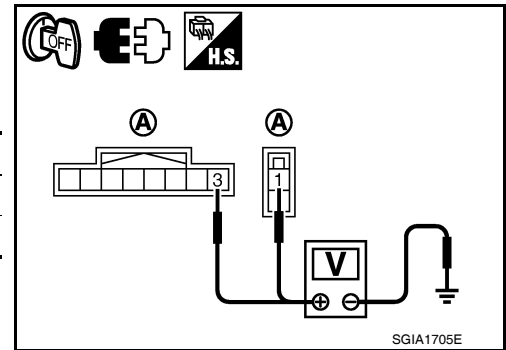

7. Connect EPS control unit harness connector.

#### OK or NG

OK >> GO TO 2.

NG >> Check the following. If any items are damaged, repair or replace damaged parts.

- 60 A fusible link (letter **f**, located in the fuse and fusible link box). Refer to [PG-4](#).
- 10 A fuse [No. 12, located in the fuse block (J/B)]. Refer to [PG-4](#).
- Harness for short or open between battery and EPS control unit harness connector E202 terminal 1.
- Harness for short or open between ignition switch and EPS control unit harness connector M37 terminal 3.

##### 2. CHECK EPS CONTROL UNIT GROUND CIRCUIT

1. Turn ignition switch "OFF".
2. Disconnect EPS control unit harness connector.

# TROUBLE DIAGNOSIS FOR SYSTEM

[EPS]

< SERVICE INFORMATION >

- Check continuity between EPS control unit harness connector (A) terminal and ground.

Connector	Terminal	Continuity
E202	2	Yes

Also check harness for short to power.

- Connect EPS control unit harness connector.

**OK or NG**

- OK >> GO TO 3.
- NG >> Repair open circuit or short to ground or short to power in harness or connectors.

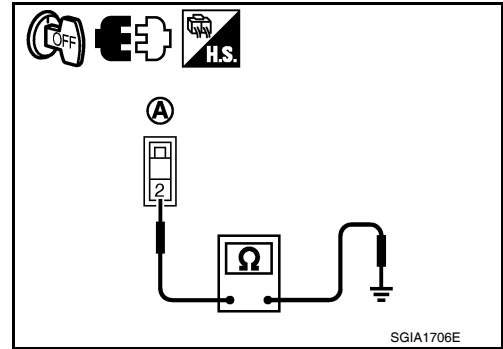

## 3. CHECK DTC

Start engine.

Does EPS warning lamp turn OFF?

- YES >> **INSPECTION END**
- NO >> Perform self-diagnosis, repair or replace damaged parts. Refer to [STC-11, "CONSULT-III Function \(EPS\)"](#).

## DTC C1604 TORQUE SENSOR

INFOID:000000006149007

STC

### CONSULT-III REFERENCE VALUE IN DATA MONITOR MODE

Data are reference value.

Monitor item (Unit)	Content	Condition	Display value
TORQUE SENSOR (Nm)	Steering wheel turning force	Engine running	Steering wheel: Not steering (There is no steering force)  0.00 Nm
		Steering wheel: Steering	0 – 8.19 Nm* (The value is changed according to steering left or right)

\*: In the front of the value, "L" is displayed at steering left and "R" is displayed at steering right.

### TERMINALS AND REFERENCE VALUES FOR EPS CONTROL UNIT

Refer to [STC-9, "EPS Control Unit Input/Output Signal Reference Value"](#).

### DIAGNOSTIC PROCEDURE

#### 1. CHECK TORQUE SENSOR SIGNAL

**With CONSULT-III**

- Start engine.
- Select "DATA MONITOR" mode for "EPS" with CONSULT-III.
- Check the value of "TORQUE SENSOR". Refer to [STC-9, "EPS Control Unit Input/Output Signal Reference Value"](#).

**Without CONSULT-III**

- Start engine.
- Check voltage between EPS control unit harness connector M87 terminals 11, 12, 13, 14 and ground. Refer to [STC-9, "EPS Control Unit Input/Output Signal Reference Value"](#).

**OK or NG**

- OK >> **INSPECTION END**
- NG >> GO TO 2.

#### 2. CHECK EPS CONTROL UNIT

Check EPS control unit input/output signal. Refer to [STC-9, "EPS Control Unit Input/Output Signal Reference Value"](#).

**OK or NG**

- OK >> GO TO 3.

# TROUBLE DIAGNOSIS FOR SYSTEM

[EPS]

< SERVICE INFORMATION >

NG >> Check EPS control unit pin terminals for damage or loose connection with harness connector. If any items are damaged, repair or replace damaged parts.

## 3.CHECK DTC

Perform the self-diagnosis, after driving the vehicle for a while.

OK or NG

OK >> **INSPECTION END**

NG >> Torque sensor is malfunctioning. Replace steering column assembly. Refer to [PS-9. "Removal and Installation"](#).

## DTC C1605 ANGLE SENSOR

INFOID:000000006149008

DIAGNOSTIC PROCEDURE

### 1.PERFORM SELF-DIAGNOSIS

 **With CONSULT-III**

1. Turn ignition switch "ON". (Do not start engine.)
2. Select "SELF-DIAG RESULTS" mode for "EPS" with CONSULT-III.
3. Touch "ERASE".
4. Turn ignition switch "OFF", and wait at least 10 seconds.
5. Start engine.
6. Perform the self-diagnosis again.

Is the "ANGLE SENSOR [C1605]" displayed?

YES >> EPS motor rotor position sensor is malfunctioning. Replace steering column assembly. Refer to [PS-9. "Removal and Installation"](#).

NO >> **INSPECTION END**

## DTC C1606 EPS MOTOR

INFOID:000000006149009

DIAGNOSTIC PROCEDURE

### 1.PERFORM SELF-DIAGNOSIS

 **With CONSULT-III**

1. Turn ignition switch "ON". (Do not start engine.)
2. Select "SELF-DIAG RESULTS" mode for "EPS" with CONSULT-III.
3. Touch "ERASE".
4. Turn ignition switch "OFF", and wait at least 10 seconds.
5. Start engine.
6. Perform the self-diagnosis again.

Is the "EPS MOTOR [C1606]" displayed?

YES >> EPS motor is malfunctioning. Replace steering column assembly. Refer to [PS-9. "Removal and Installation"](#).

NO >> **INSPECTION END**

## DTC C1608 CONTROL UNIT

INFOID:000000006149010

DIAGNOSTIC PROCEDURE

### 1.PERFORM SELF-DIAGNOSIS

 **With CONSULT-III**

1. Turn ignition switch "ON". (Do not start engine.)
2. Select "SELF-DIAG RESULTS" mode for "EPS" with CONSULT-III.
3. Touch "ERASE".
4. Turn ignition switch "OFF", and wait at least 10 seconds.
5. Start engine.
6. Perform the self-diagnosis again.

Is the "CONTROL UNIT [C1608]" displayed?



# TROUBLE DIAGNOSIS FOR SYSTEM

[EPS]

< SERVICE INFORMATION >

- YES >> Replace steering column assembly. Refer to [PS-9, "Removal and Installation"](#).  
NO >> **INSPECTION END**

## DTC U1000 CAN COMM CIRCUIT

INFOID:000000006149011

### DIAGNOSTIC PROCEDURE

#### 1. CHECK CAN COMMUNICATION CIRCUIT

##### With CONSULT-III

1. Turn ignition switch "ON" and start engine.
2. Select "SELF-DIAG RESULTS" mode for "EPS" with CONSULT-III.
3. Perform the self-diagnosis.

Is the "CAN COMM CIRCUIT [U1000]" displayed?

- YES >> Print out CONSULT-III screen and go to [LAN-13, "CAN Diagnosis with CONSULT-III"](#).  
NO >> **INSPECTION END**

## DTC U1200 CAN VHCL SPEED ABS

INFOID:000000006149012

### CONSULT-III REFERENCE VALUE IN DATA MONITOR MODE

Data are reference value.

Monitor item (Unit)	Content	Condition	Display value
VEHICLE SPEED (km/h) or (mph)	Vehicle speed	Vehicle stopped	0 km/h (0 mph)
		While driving	Approximately equal to the indication on speedometer (Inside of $\pm 10\%$ )

\*: It is not a malfunction, though it might not be corresponding just after ignition switch is turned ON.

### DIAGNOSTIC PROCEDURE

#### 1. CHECK DTC WITH ABS

Perform self-diagnosis with ABS actuator and electric unit (control unit). Refer to [BRC-20, "CONSULT-III Function \(ABS\)"](#).

Is any malfunction detected by self-diagnosis?

- YES >> Check the malfunctioning system.  
NO >> GO TO 2.

#### 2. CHECK EPS CONTROL UNIT

Check EPS control unit input/output signal. Refer to [STC-9, "EPS Control Unit Input/Output Signal Reference Value"](#).

OK or NG

- OK >> GO TO 3.  
NG >> Check EPS control unit pin terminals for damage or loose connection with harness connector. If any items are damaged, repair or replace damaged parts.

#### 3. CHECK DTC

Perform the self-diagnosis, after driving the vehicle for a while.

OK or NG

- OK >> **INSPECTION END**  
NG >> Perform self-diagnosis with ABS actuator and electric unit (control unit). Refer to [BRC-20, "CONSULT-III Function \(ABS\)"](#).

# TROUBLE DIAGNOSIS FOR SYMPTOMS

< SERVICE INFORMATION >

[EPS]

## TROUBLE DIAGNOSIS FOR SYMPTOMS

### EPS Warning Lamp Does Not Turn ON

INFOID:000000006149013

SYMPTOM:

**EPS warning lamp does not turn ON when ignition switch to “ON”.**

DIAGNOSTIC PROCEDURE

#### 1. CHECK SYSTEM FOR CAN COMMUNICATION LINE

Perform self-diagnosis. Refer to [STC-11, "CONSULT-III Function \(EPS\)"](#) .

Is the “CAN COMM CIRCUIT [U1000]” displayed?

YES >> Perform trouble diagnosis for CAN communication line. Refer to [STC-17, "DTC U1000 CAN COMM CIRCUIT"](#) .

NO >> GO TO 2.

#### 2. CHECK EPS CONTROL UNIT

Check EPS control unit input/output signal. Refer to [STC-9, "EPS Control Unit Input/Output Signal Reference Value"](#) .

OK or NG

OK >> GO TO 3.

NG >> Check EPS control unit pin terminals for damage or loose connection with harness connector. If any items are damaged, repair or replace damaged parts.

#### 3. SYMPTOM CHECK

Check again.

OK or NG

OK >> **INSPECTION END**

NG >> Replace combination meter. Refer to [DI-22, "Removal and Installation"](#) .

### EPS Warning Lamp Does Not Turn OFF

INFOID:000000006149014

SYMPTOM:

**EPS warning lamp does not turn OFF for several seconds after starting the engine.**

DIAGNOSTIC PROCEDURE

#### 1. CHECK SELF-DIAGNOSTIC RESULTS

Perform self-diagnosis. Refer to [STC-11, "CONSULT-III Function \(EPS\)"](#) .

Is any malfunction detected by self-diagnosis?

YES >> Check the malfunctioning system.

NO >> GO TO 2.

#### 2. CHECK EPS CONTROL UNIT POWER SUPPLY CIRCUIT

1. Turn ignition switch “OFF”.
2. Disconnect EPS control unit harness connector.
3. Turn ignition switch “ON”. (Do not start engine.)
4. Check voltage between EPS control unit harness connector (A) terminals and ground.

Connector	Terminal	Voltage
M37	3 – Ground	Battery voltage
E202	1 – Ground	Battery voltage

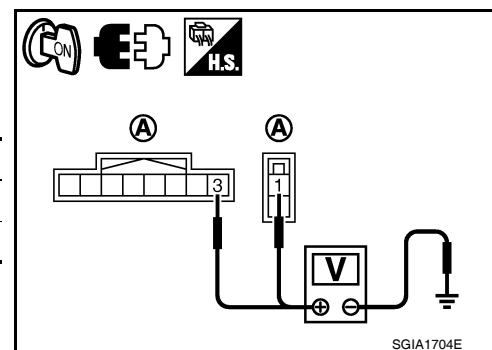

# TROUBLE DIAGNOSIS FOR SYMPTOMS

[EPS]

## < SERVICE INFORMATION >

- Turn ignition switch "OFF".
- Check voltage between EPS control unit harness connector (A) terminals and ground.

Connector	Terminal	Voltage
M37	3 – Ground	Approx. 0 V
E202	1 – Ground	Battery voltage

- Connect EPS control unit harness connector.

### OK or NG

- OK >> GO TO 3.
- NG >> Check the following. If any items are damaged, repair or replace damaged parts.
- 60 A fusible link (letter f, located in the fuse and fusible link box). Refer to [PG-4](#).
  - 10 A fuse [No. 12, located in the fuse block (J/B)]. Refer to [PG-4](#).
  - Harness for short or open between battery and EPS control unit harness connector E202 terminal 1.
  - Harness for short or open between ignition switch and EPS control unit harness connector M37 terminal 3.

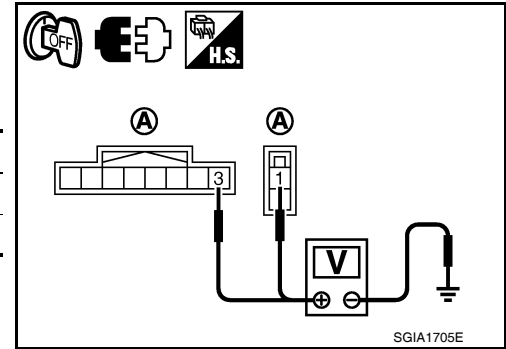

## 3.CHECK EPS CONTROL UNIT GROUND CIRCUIT

- Turn ignition switch "OFF".
- Disconnect EPS control unit harness connector.
- Check continuity between EPS control unit harness connector (A) terminal and ground.

Connector	Terminal	Continuity
E202	2	YES

Also check harness for short to power.

- Connect EPS control unit harness connector.

### OK or NG

- OK >> GO TO 4.
- NG >> Repair open circuit or short to ground or short to power in harness or connectors.

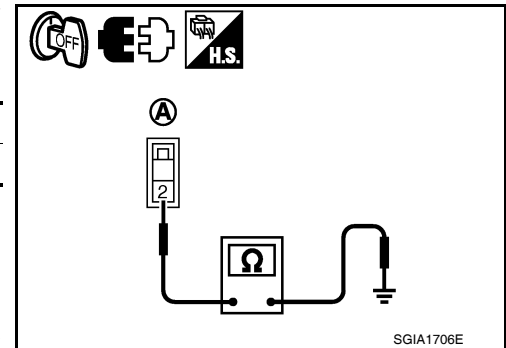

## 4.CHECK EPS CONTROL UNIT

Check EPS control unit input/output signal. Refer to [STC-9, "EPS Control Unit Input/Output Signal Reference Value"](#).

### OK or NG

- OK >> GO TO 5.
- NG >> Check EPS control unit pin terminals for damage or loose connection with harness connector. If any items are damaged, repair or replace damaged parts.

## 5.SYMPTOM CHECK

Check again.

### OK or NG

- OK >> **INSPECTION END**
- NG >> Replace combination meter. Refer to [DI-22, "Removal and Installation"](#).

## Steering Wheel Turning Force Is Heavy or Light

INFOID:000000006149015

SYMPTOM:

**Steering wheel turning force is heavy or light, while driving.**

### DIAGNOSTIC PROCEDURE

#### 1.CHECK SYSTEM FOR CAN COMMUNICATION LINE

Perform self-diagnosis. Refer to [STC-11, "CONSULT-III Function \(EPS\)"](#).

## TROUBLE DIAGNOSIS FOR SYMPTOMS

[EPS]

< SERVICE INFORMATION >

Is the "CAN COMM CIRCUIT [U1000]" displayed?

YES >> Perform trouble diagnosis for CAN communication line. Refer to [STC-17, "DTC U1000 CAN COMM CIRCUIT"](#).

NO-1 >> With ABS: GO TO 2.

NO-2 >> Without ABS: GO TO 3.

### 2. CHECK VEHICLE SPEED SIGNAL FROM ABS ACTUATOR AND ELECTRIC UNIT (CONTROL UNIT)

Perform self-diagnosis with ABS actuator and electric unit (control unit). Refer to [BRC-20, "CONSULT-III Function \(ABS\)"](#).

Is any malfunction detected by self-diagnosis?

YES >> Check the malfunctioning system.

NO >> GO TO 4.

### 3. CHECK VEHICLE SPEED SIGNAL FROM TRANSMISSION CONTROL MODULE (TCM)

Perform self-diagnosis with TCM. Refer to [CVT-47, "CONSULT-III Function \(TRANSMISSION\)"](#).

Is any malfunction detected by self-diagnosis?

YES >> Check the malfunctioning system.

NO >> GO TO 4.

### 4. CHECK COMBINATION METER SIGNAL

Perform self-diagnosis with combination meter. Refer to [DI-15, "CONSULT-III Function \(METER/M&A\)"](#).

Is any malfunction detected by self-diagnosis?

YES >> Check the malfunctioning system.

NO >> GO TO 5.

### 5. CHECK ENGINE STATUS SIGNAL

Perform self-diagnosis for ECM. Refer to [EC-1214, "CONSULT-III Function \(ENGINE\)"](#).

Is any malfunction detected by self-diagnosis?

YES >> Check the malfunctioning system.

NO >> GO TO 6.

### 6. CHECK EPS MOTOR SYSTEM

Perform trouble diagnosis for EPS motor. Refer to [STC-16, "DTC C1606 EPS MOTOR"](#).

OK or NG

OK >> GO TO 7.

NG >> Repair or replace damaged parts.

### 7. CHECK EPS CONTROL UNIT

Check EPS control unit input/output signal. Refer to [STC-9, "EPS Control Unit Input/Output Signal Reference Value"](#).

OK or NG

OK >> GO TO 8.

NG >> Check EPS control unit pin terminals for damage or loose connection with harness connector. If any items are damaged, repair or replace damaged parts.

### 8. SYMPTOM CHECK

Check again.

OK or NG

OK >> **INSPECTION END**

NG >> Check the steering wheel turning force because there may be mechanical malfunction. Refer to [PS-6, "On-Vehicle Inspection and Service"](#).

Unbalance Steering Wheel Turning Force and Return Between Right and Left

INFOID:000000006149016

SYMPTOM:

**Unbalance steering wheel turning force and return between right and left, while driving.**

# TROUBLE DIAGNOSIS FOR SYMPTOMS

[EPS]

< SERVICE INFORMATION >

## DIAGNOSTIC PROCEDURE

### 1.CHECK EPS WARNING LAMP

Confirm EPS warning lamp during engine running.

Does EPS warning lamp turn OFF?

YES >> GO TO 2.

NO >> Go to [STC-18, "EPS Warning Lamp Does Not Turn OFF"](#).

### 2.CHECK WHEEL ALIGNMENT

Check wheel alignment. Refer to [FSU-7, "Wheel Alignment Inspection"](#).

OK or NG

OK >> GO TO 3.

NG >> Adjust wheel alignment. Refer to [FSU-7, "Wheel Alignment Inspection"](#).

### 3.CHECK EPS CONTROL UNIT

Check EPS control unit input/output signal. Refer to [STC-9, "EPS Control Unit Input/Output Signal Reference Value"](#).

OK or NG

OK >> GO TO 4.

NG >> Check EPS control unit pin terminals for damage or loose connection with harness connector. If any items are damaged, repair or replace damaged parts.

### 4.SYMPTOM CHECK

Check again.

OK or NG

OK >> **INSPECTION END**

NG >> Check the steering wheel turning force because there may be mechanical malfunction. Refer to [PS-6, "On-Vehicle Inspection and Service"](#).

## Unbalance Steering Wheel Turning Force (Torque Variation)

INFOID:000000006149017

SYMPTOM:

**Unbalance steering wheel turning force, while driving (Torque variation).**

## DIAGNOSTIC PROCEDURE

### 1.CHECK EPS WARNING LAMP

Confirm EPS warning lamp during engine running.

Does EPS warning lamp turn OFF?

YES >> GO TO 2.

NO >> Go to [STC-18, "EPS Warning Lamp Does Not Turn OFF"](#).

### 2.CHECK STEERING COLUMN INTERMEDIATE SHAFT

Check the connection between intermediate shaft and the mounting part of steering column assembly and steering gear assembly. Refer to [PS-13, "Removal and Installation"](#).

OK or NG

OK >> GO TO 3.

NG >> Repair or replace damaged parts.

### 3.CHECK EPS CONTROL UNIT

Check EPS control unit input/output signal. Refer to [STC-9, "EPS Control Unit Input/Output Signal Reference Value"](#).

OK or NG

OK >> GO TO 4.

NG >> Check EPS control unit pin terminals for damage or loose connection with harness connector. If any items are damaged, repair or replace damaged parts.

### 4.SYMPTOM CHECK

A

B

C

D

E

F

STC

H

I

J

K

L

M

N

O

P

## TROUBLE DIAGNOSIS FOR SYMPTOMS

[EPS]

< SERVICE INFORMATION >

---

Check again.

OK or NG

OK >> **INSPECTION END**

NG >> Check the steering wheel turning force because there may be mechanical malfunction. Refer to [PS-6, "On-Vehicle Inspection and Service"](#).