

SECTION **CL**  
CLUTCH

A  
B  
C

CL

CONTENTS

E

<b>PRECAUTION</b> .....	2	Exploded View .....	10	F
<b>PRECAUTIONS</b> .....	2	Removal and Installation .....	10	
Precaution for Supplemental Restraint System (SRS) "AIR BAG" and "SEAT BELT PRE-TENSIONER" .....	2	Inspection and Adjustment .....	11	
Precaution for Procedure without Cowl Top Cover.....	2	<b>CLUTCH MASTER CYLINDER</b> .....	12	G
Service Notice or Precautions for Clutch .....	2	Exploded View .....	12	
<b>PREPARATION</b> .....	3	Removal and Installation .....	12	
<b>PREPARATION</b> .....	3	Inspection and Adjustment .....	13	H
Special Service Tools .....	3	<b>CLUTCH PIPING</b> .....	14	
Commercial Service Tools .....	3	Exploded View .....	14	I
<b>SYMPTOM DIAGNOSIS</b> .....	4	Hydraulic Layout .....	14	
<b>NOISE, VIBRATION AND HARSHNESS (NVH) TROUBLESHOOTING</b> .....	4	Removal and Installation .....	14	J
NVH Troubleshooting Chart .....	4	Inspection and Adjustment .....	15	
<b>PERIODIC MAINTENANCE</b> .....	5	<b>CSC (CONCENTRIC SLAVE CYLINDER)</b> .....	16	K
<b>CLUTCH PEDAL</b> .....	5	Exploded View .....	16	
Inspection and Adjustment .....	5	Removal and Installation .....	16	
<b>CLUTCH FLUID</b> .....	7	Inspection and Adjustment .....	16	
Inspection .....	7	<b>CLUTCH DISC AND CLUTCH COVER</b> .....	17	L
Draining .....	7	Exploded View .....	17	
Refilling .....	8	Removal and Installation .....	17	
Air Bleeding .....	9	Inspection .....	18	M
<b>REMOVAL AND INSTALLATION</b> .....	10	<b>SERVICE DATA AND SPECIFICATIONS (SDS)</b> .....	20	N
<b>CLUTCH PEDAL</b> .....	10	<b>SERVICE DATA AND SPECIFICATIONS (SDS)</b> .....	20	
		General Specifications .....	20	O
		Clutch Pedal .....	20	
		Clutch Disc .....	20	
		Clutch Cover .....	20	P

# PRECAUTIONS

< PRECAUTION >

## PRECAUTION

### PRECAUTIONS

#### Precaution for Supplemental Restraint System (SRS) "AIR BAG" and "SEAT BELT PRE-TENSIONER"

INFOID:000000008971166

The Supplemental Restraint System such as "AIR BAG" and "SEAT BELT PRE-TENSIONER", used along with a front seat belt, helps to reduce the risk or severity of injury to the driver and front passenger for certain types of collision. Information necessary to service the system safely is included in the SR and SB section of this Service Manual.

#### **WARNING:**

- To avoid rendering the SRS inoperative, which could increase the risk of personal injury or death in the event of a collision which would result in air bag inflation, all maintenance must be performed by an authorized NISSAN/INFINITI dealer.
- Improper maintenance, including incorrect removal and installation of the SRS, can lead to personal injury caused by unintentional activation of the system. For removal of Spiral Cable and Air Bag Module, see the SR section.
- Do not use electrical test equipment on any circuit related to the SRS unless instructed to in this Service Manual. SRS wiring harnesses can be identified by yellow and/or orange harnesses or harness connectors.

#### PRECAUTIONS WHEN USING POWER TOOLS (AIR OR ELECTRIC) AND HAMMERS

#### **WARNING:**

- When working near the Airbag Diagnosis Sensor Unit or other Airbag System sensors with the Ignition ON or engine running, DO NOT use air or electric power tools or strike near the sensor(s) with a hammer. Heavy vibration could activate the sensor(s) and deploy the air bag(s), possibly causing serious injury.
- When using air or electric power tools or hammers, always switch the Ignition OFF, disconnect the battery and wait at least 3 minutes before performing any service.

#### Precaution for Procedure without Cowl Top Cover

INFOID:000000008768962

When performing the procedure after removing cowl top cover, cover the lower end of windshield with urethane, etc. to prevent damage to windshield.

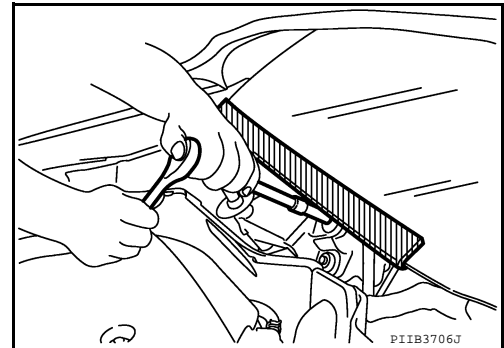

#### Service Notice or Precautions for Clutch

INFOID:000000008768963

#### **WARNING:**

After cleaning clutch disc, wipe it with a dust collector. Do not use compressed air.

#### **CAUTION:**

- Clutch fluid use refer to [MA-12, "Fluids and Lubricants"](#).
- Do not reuse drained clutch fluid.
- Keep painted surface on the body or other parts free of clutch fluid. If it spills, wipe up immediately and wash the affected area with water.
- Do not use mineral oils such as gasoline or kerosene. It will ruin the rubber parts of the hydraulic system.
- Do not reuse CSC (Concentric Slave Cylinder). Because CSC slides back to the original position every time when removing transaxle assembly. At this timing, dust on the sliding parts may damage a seal of CSC and may cause clutch fluid leakage. Refer to [CL-16, "Removal and Installation"](#).
- Do not disassemble clutch master cylinder and CSC.

# PREPARATION

< PREPARATION >

## PREPARATION

### PREPARATION

#### Special Service Tools

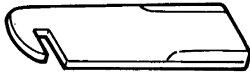

INFOID:000000008768964

The actual shapes of Kent-Moore tools may differ from those of special service tools illustrated here.

Tool number (Kent-Moore No.) Tool name	Description
ST20050240 ( — ) Diaphragm adjusting wrench  <p style="text-align: center; font-size: small;">ZZA0508D</p>	Adjusting unevenness of diaphragm spring lever

#### Commercial Service Tools

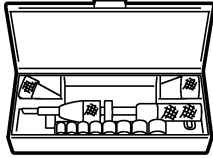
INFOID:000000008768965

Tool name	Description
Clutch aligner  <p style="text-align: center; font-size: small;">MCIB0404E</p>	Installing clutch disc
Power tool  <p style="text-align: center; font-size: small;">PIIB1407E</p>	Loosening nuts, screws and bolts

# NOISE, VIBRATION AND HARSHNESS (NVH) TROUBLESHOOTING

< SYMPTOM DIAGNOSIS >

## SYMPTOM DIAGNOSIS

### NOISE, VIBRATION AND HARSHNESS (NVH) TROUBLESHOOTING

#### NVH Troubleshooting Chart

INFOID:000000008768966

Use the chart below to find the cause of the symptom. The numbers indicate the order of the inspection. If necessary, repair or replace these parts.

SYMPTOM		SUSPECTED PARTS (Possible cause)															
		CLUTCH PEDAL (Inspection and adjustment)	CLUTCH LINE (Air in line)	ENGINE MOUNTING (Loose)	CSC (Concentric Slave Cylinder) (Worn, dirty or damaged)	CLUTCH DISC (Out of true)	CLUTCH DISC (Runout is excessive)	CLUTCH DISC (Lining broken)	CLUTCH DISC (Dirty or burned)	CLUTCH DISC (Oily)	CLUTCH DISC (Worn out)	CLUTCH DISC (Hardened)	CLUTCH DISC (Lack of spline grease)	DIAPHRAGM SPRING (Damaged)	DIAPHRAGM SPRING (Out of tip alignment)	PRESSURE PLATE (Distortion)	FLYWHEEL (Distortion)
Reference		<a href="#">CL-5</a>	<a href="#">CL-9</a>	<a href="#">EM-89</a>	<a href="#">CL-16</a>						<a href="#">CL-17</a>					<a href="#">EM-103</a>	
Symptom	Clutch grabs/chatters			1			2			2	2	2			2		
	Clutch pedal spongy		1		2												
	Clutch noisy				1												
	Clutch slips	1								2	2			3		4	5
	Clutch does not disengage	1	2		3	3	3	3	3	3			3	4	4	5	

# CLUTCH PEDAL

< PERIODIC MAINTENANCE >

## PERIODIC MAINTENANCE

### CLUTCH PEDAL

#### Inspection and Adjustment

INFOID:000000008768967

#### INSPECTION

##### The Height of Clutch Pedal

1. Pull back the floor trim and remove front floor spacer (LH) for access to floor panel.
2. Check that the clutch pedal height ( $H_1$ ) from the floor panel (1) is within the reference value.

**Clutch pedal height ( $H_1$ )** : Refer to [CL-20, "Clutch Pedal"](#).

3. Replace clutch pedal if the height is outside the reference value.

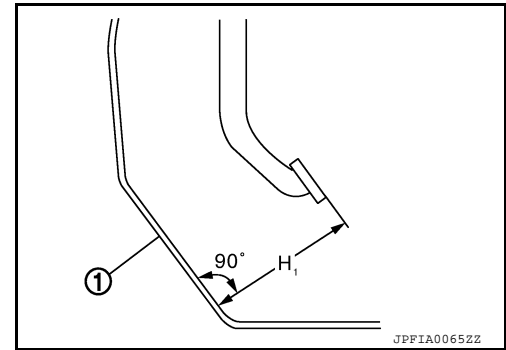

##### Position of Clutch Interlock Switch

Check that the clearance (C) between the thread end of clutch interlock switch (1) and stopper rubber (2) is within the specification range while clutch pedal is fully depressed.

**Clearance (C)** : Refer to [CL-20, "Clutch Pedal"](#).

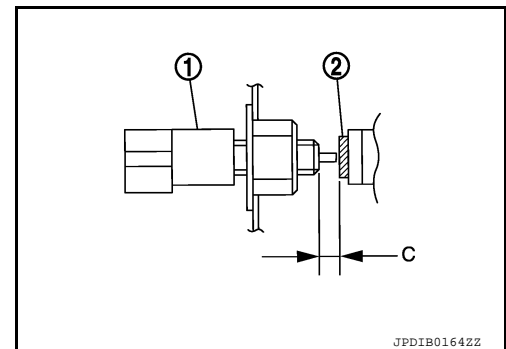

##### Position of Clutch Pedal Position Switch (if equipped)

Check that the clearance (A) between the thread end of clutch pedal position switch (1) and clutch pedal (2) is within the specification range while clutch pedal is fully released.

**Clearance (A)** : Refer to [CL-20, "Clutch Pedal"](#).

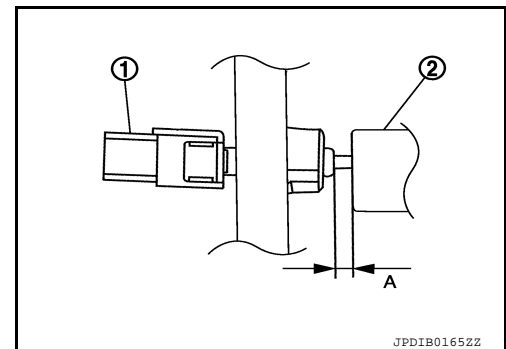

#### ADJUSTMENT

##### Position of Clutch Interlock Switch

1. Disconnect the clutch interlock switch harness connector.

# CLUTCH PEDAL

## < PERIODIC MAINTENANCE >

2. Rotate the clutch interlock switch (1) 45 degrees counterclockwise to release from bracket.
3. With the clutch pedal fully depressed, insert the clutch interlock switch (1) until it contacts the stopper rubber (2).
4. Rotate the clutch interlock switch 45 degrees clockwise to set clearance (A) between the clutch interlock switch (1) and stopper rubber (2).

**CAUTION:**

The clearance (C) must be within the specification range.

Clearance (C) : Refer to [CL-20, "Clutch Pedal"](#).

**NOTE:**

Fully depressed clutch pedal means a clutch pedal condition that the clutch pedal lever contacts the pedal stopper rubber.

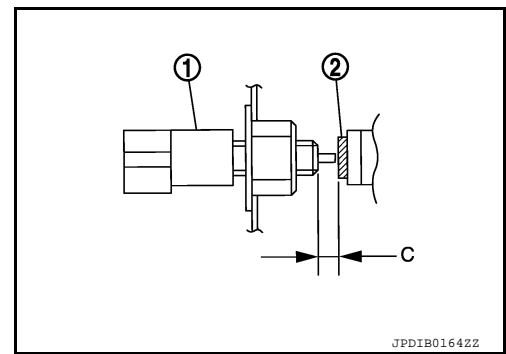

### Position of Clutch Pedal Position Switch (if equipped)

1. Disconnect the clutch pedal position switch harness connector.
2. Rotate the clutch pedal position switch 45 degrees counterclockwise to release from bracket.
3. Insert the clutch pedal position switch (1) until it contacts the clutch pedal (2).
4. Rotate the clutch pedal position switch 45 degrees clockwise to set clearance (A) between the clutch pedal position switch (1) and clutch pedal (2).

Clearance (A) : Refer to [CL-20, "Clutch Pedal"](#).

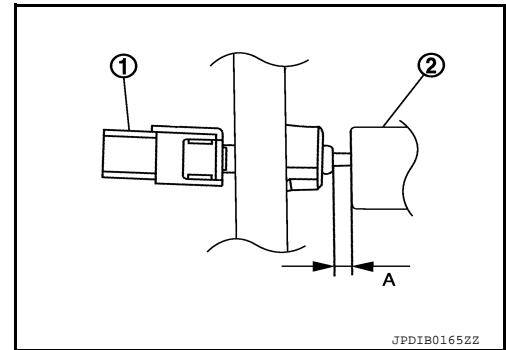

# CLUTCH FLUID

< PERIODIC MAINTENANCE >

## CLUTCH FLUID

### Inspection

INFOID:000000008768972

#### FLUID LEAKAGE

- Check clutch line for cracks, deterioration or other damage. Replace any damaged parts.
- Check for fluid leakage by fully depressing clutch pedal while engine is running.

**CAUTION:**

**If leakage occurs around connections, reinstall the lines or replace damaged parts, if necessary.**

#### FLUID LEVEL

- Check that the fluid level in the reservoir tank is within the specified range, between the MAX and MIN lines as shown.
- Visually check for any clutch fluid leaks around the reservoir tank.
- Check the clutch system for any leaks if the fluid level is extremely low (lower than MIN).

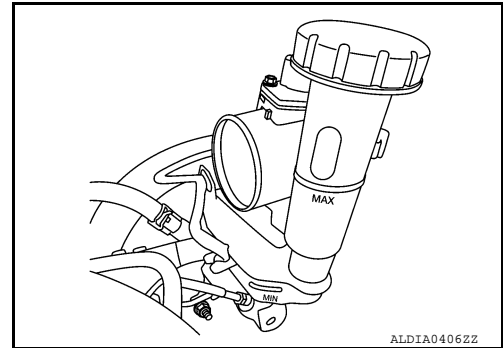

### Draining

INFOID:000000008768973

**CAUTION:**

**Do not spill clutch fluid onto painted surfaces. If fluid spills, wipe up immediately and wash the affected area with water.**

1. Connect a transparent vinyl hose to air bleeder of bleeding connector (1).

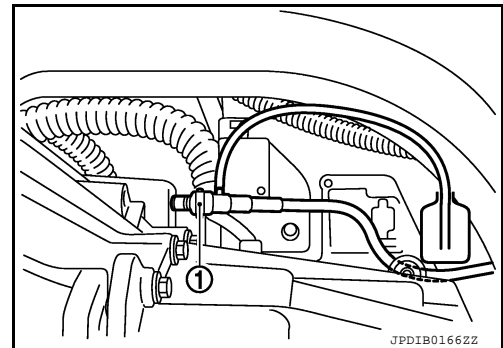

2. Press the lock pin (1) into the bleeding connector (2), and maintain the position.

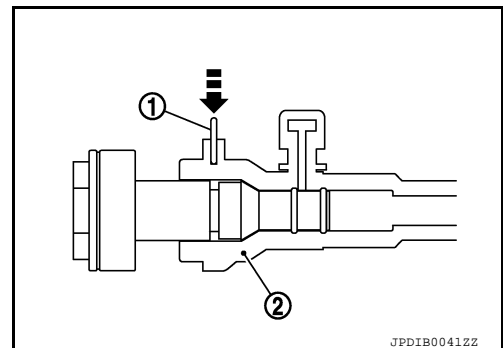

A  
B  
C  
CL  
E  
F  
G  
H  
I  
J  
K  
L  
M  
N  
O  
P

# CLUTCH FLUID

## < PERIODIC MAINTENANCE >

- Slide bleeding connector (1) in the direction of the arrow (➡) as shown.

(2) : Clutch housing

**Dimension (A) : 10 mm (0.39 in)**

- Depress clutch pedal to gradually discharge clutch fluid.

**CAUTION:**

**Clutch tube is under hydraulic pressure; do not allow the clutch tube to disconnect from the bleeding connector.**

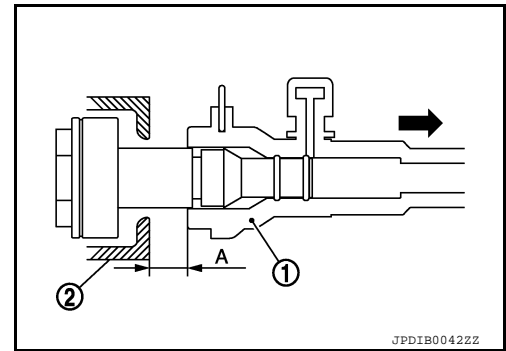

INFOID:000000008768974

## Refilling

**CAUTION:**

**Do not spill clutch fluid onto painted surfaces. If fluid spills, wipe up immediately and wash the affected area with water.**

- Check that there is no foreign material in reservoir tank, and then fill with new clutch fluid.

**CAUTION:**

**Do not reuse drained clutch fluid.**

- Connect a transparent vinyl hose to air bleeder of bleeding connector (1).

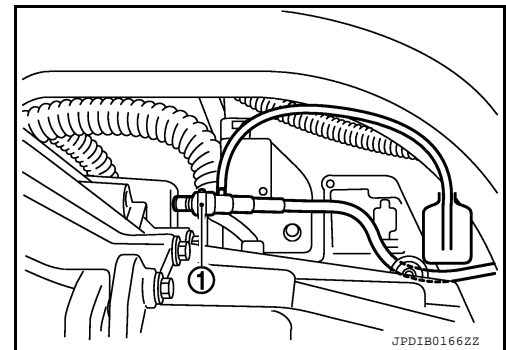

- Press the lock pin (1) into the bleeding connector (2), and maintain the position.

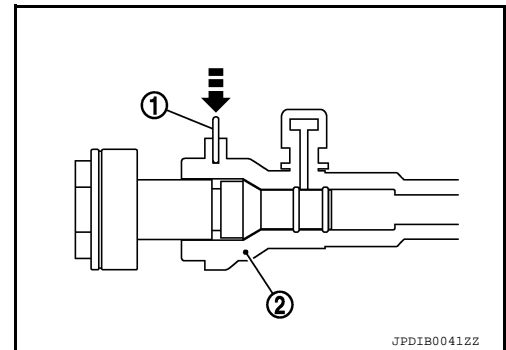

- Slide bleeding connector (1) for the specified distance (A) in the direction of the arrow (➡) as shown.

(2) : Clutch housing

**Dimension "A" : 10 mm (0.39 in)**

- Slowly depress clutch pedal to the full stroke position, and then release the pedal.

**CAUTION:**

**Clutch tube is under hydraulic pressure; do not allow the clutch tube to disconnect from the clutch housing.**

- Repeat step 5 at intervals of 2 or 3 seconds until new clutch fluid is discharged.

**CAUTION:**

**Monitor clutch fluid level in reservoir tank so as not to empty the tank.**

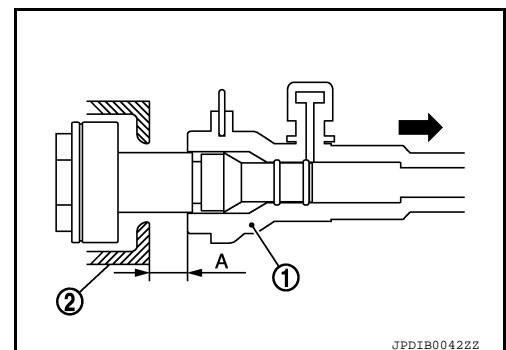



# CLUTCH FLUID

## < PERIODIC MAINTENANCE >

- Return clutch tube and lock pin in their original positions while clutch pedal is depressed.
- Perform the air bleeding. Refer to [CL-9, "Air Bleeding"](#).

### Air Bleeding

INFOID:000000008768975

#### CAUTION:

- Monitor clutch fluid level in reservoir tank so as not to empty the tank.
- Do not spill clutch fluid onto painted surfaces. If fluid spills, wipe up immediately and wash the affected area with water.

#### NOTE:

Do not use a vacuum assist or any other type of power bleeder on this system. Use of a vacuum assist or power bleeder will not purge all the air from the system.

- Fill reservoir tank with new clutch fluid.

#### CAUTION:

Do not reuse drained clutch fluid.

- Connect a transparent vinyl hose to air bleeder of bleeding connector (1).
- "Depress and release the clutch pedal slowly and fully 15 times at an interval of 2 to 3 seconds and release the clutch pedal.

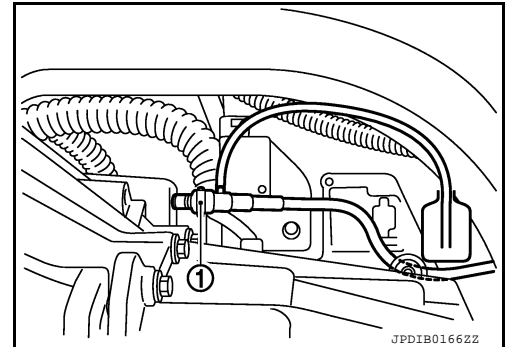

- Press the lock pin (1) into the bleeding connector (2), and maintain the position.

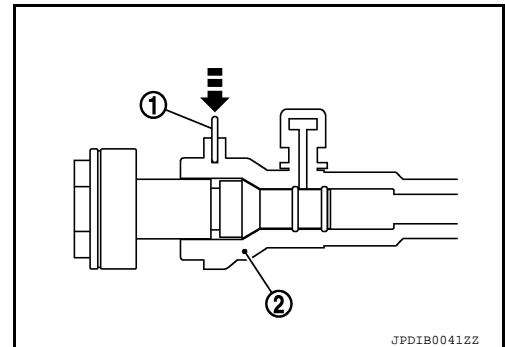

- Slide bleeding connector (1) in the direction of the arrow (➔) as shown and immediately depress the clutch pedal and hold it, to bleed the air from the system.

(2) : Clutch housing

Dimension "A" : 10 mm (0.39 in)

#### CAUTION:

Clutch tube is under hydraulic pressure; do not allow the clutch tube to disconnect from the clutch housing.

- Return clutch tube and lock pin in their original positions.
- Release clutch pedal and wait for 5 seconds.
- Repeat steps 3 to 7 until no bubbles are observed in the clutch fluid.
- Check that the fluid level in the reservoir tank is within the specified range after air bleeding. Refer to [CL-7, "Inspection"](#).

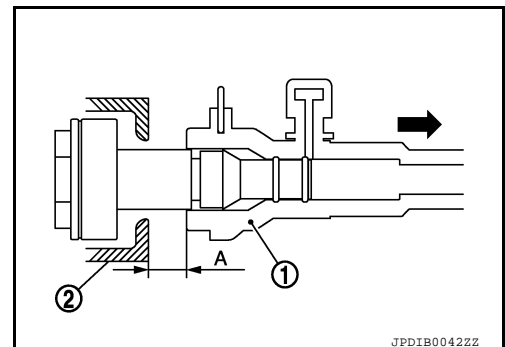

# CLUTCH PEDAL

< REMOVAL AND INSTALLATION >

## REMOVAL AND INSTALLATION

### CLUTCH PEDAL

Exploded View

INFOID:000000008768976

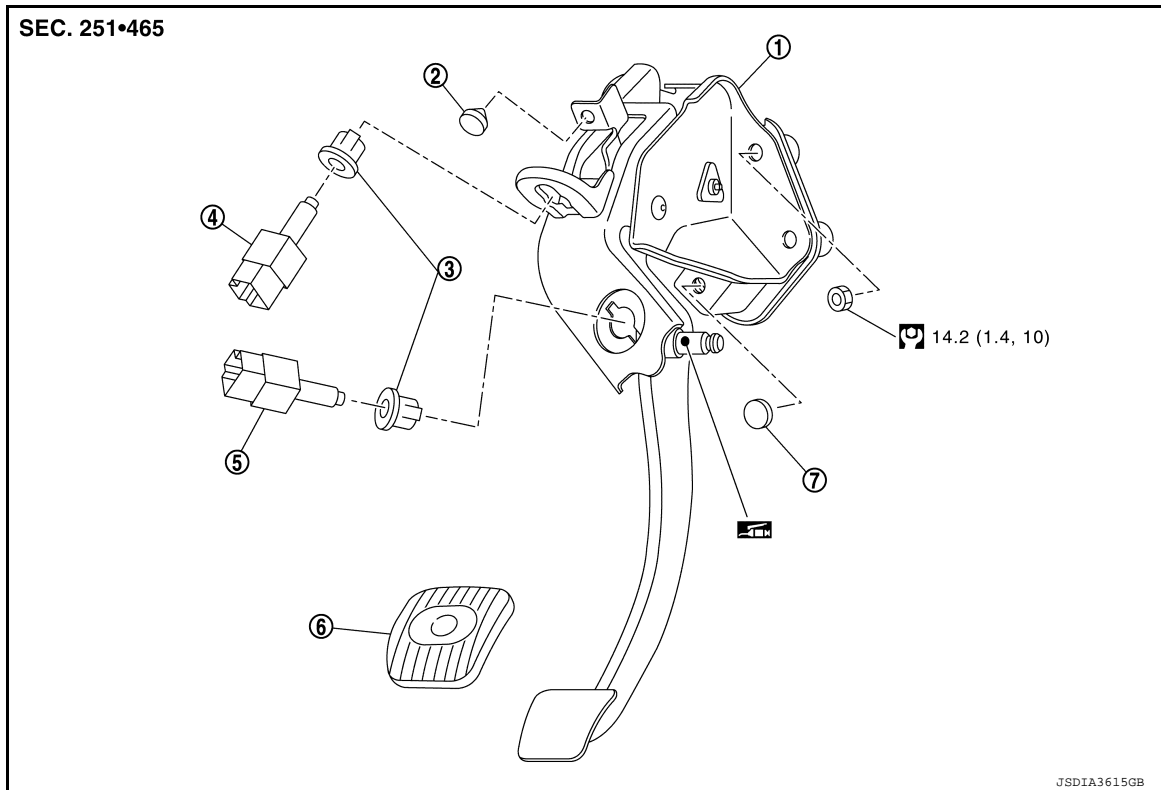

- |                            |                                 |              |
|----------------------------|---------------------------------|--------------|
| 1. Clutch pedal            | 2. Stopper rubber               | 3. Clip      |
| 4. Clutch interlock switch | 5. Clutch pedal position switch | 6. Pedal pad |
| 7. Pedal stopper rubber    |                                 |              |

### Removal and Installation

INFOID:000000008768977

#### REMOVAL

1. Remove instrument lower panel (LH). Refer to [IP-21, "Removal and Installation"](#).
2. Disconnect clutch pedal position switch harness connector (if equipped).
3. Disconnect clutch interlock switch harness connector.
4. Disconnect clip of harness from clutch pedal.
5. Remove clutch master cylinder rod end from clutch pedal.
6. Remove clutch pedal position switch and clip from clutch pedal (if equipped).
7. Remove clutch interlock switch and clip from clutch pedal.
8. Remove clutch pedal from the vehicle.
9. Remove pedal pad from clutch pedal.
10. Remove stopper rubber and pedal stopper rubber from clutch pedal, using a suitable remover.

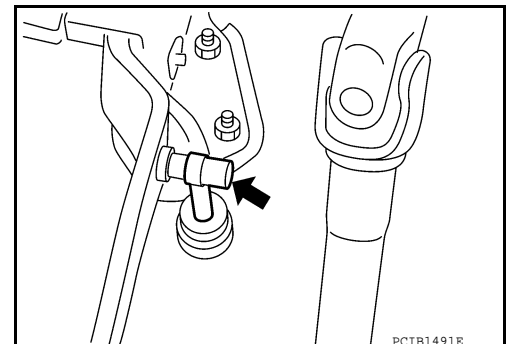

#### INSTALLATION

Installation is in the reverse order of removal.

# CLUTCH PEDAL

## < REMOVAL AND INSTALLATION >

---

### **CAUTION:**

After applying recommended grease, press clutch master cylinder rod end into clutch pedal until it stops.

### Inspection and Adjustment

INFOID:000000008768978

#### INSPECTION AFTER REMOVAL

- Check clutch pedal for bend, damage, or a cracked weld. If bend, damage, or a cracked weld is found, replace clutch pedal.
- Check pedal stopper rubber (if equipped). If damage or deformation is found, replace pedal stopper rubber. (if equipped)
- Check stopper rubber. If damage or deformation is found, replace stopper rubber.
- Check pedal pad. If wear or damage is found, replace pedal pad.

#### INSPECTION AFTER INSTALLATION

- Check the height of clutch pedal. Refer to [CL-5. "Inspection and Adjustment"](#).
- Check the clutch interlock switch position. Refer to [CL-5. "Inspection and Adjustment"](#).
- Check the clutch pedal position switch position. Refer to [CL-5. "Inspection and Adjustment"](#).

#### ADJUSTMENT AFTER INSTALLATION

- Adjust the clutch interlock switch position. Refer to [CL-5. "Inspection and Adjustment"](#).
- Adjust the clutch pedal position switch position. Refer to [CL-5. "Inspection and Adjustment"](#).

A  
B  
C  
CL  
E  
F  
G  
H  
I  
J  
K  
L  
M  
N  
O  
P

# CLUTCH MASTER CYLINDER

< REMOVAL AND INSTALLATION >

## CLUTCH MASTER CYLINDER

Exploded View

INFOID:000000008768982

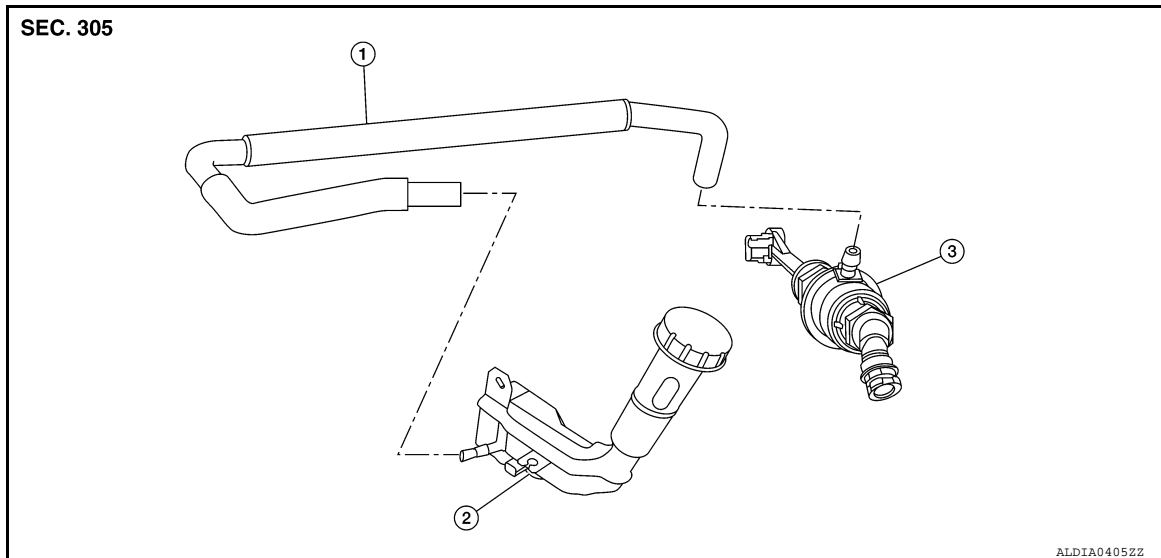

1. Reservoir hose

2. Reservoir tank

3. Clutch master cylinder

## Removal and Installation

INFOID:000000008768983

### REMOVAL

#### CAUTION:

• Keep painted surface on the body or other parts free of clutch fluid. If it spills, wipe up immediately and wash the affected area with water.

• Do not disassemble clutch master cylinder.

1. Drain clutch fluid. Refer to [CL-7, "Draining"](#).
2. Remove air cleaner body assembly. Refer to [EM-25, "Removal and Installation"](#).
3. Remove reservoir hose from reservoir tank and clutch master cylinder.
4. Remove clutch master cylinder rod end (←) from clutch pedal.

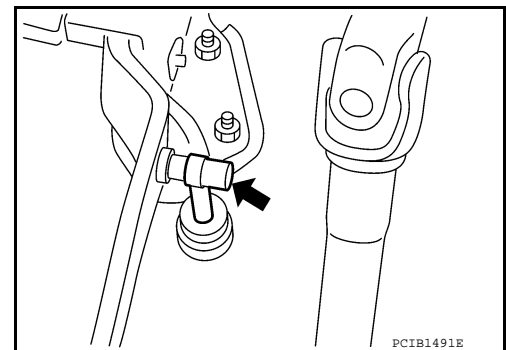

5. Pull up the lock pin (1) from connector of clutch master cylinder (2) and separate clutch tube (3).
6. Rotate clutch master cylinder clockwise by 45 degrees, and then remove clutch master cylinder from the vehicle.

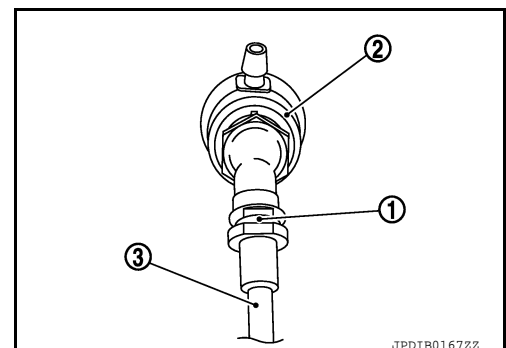

# CLUTCH MASTER CYLINDER

## < REMOVAL AND INSTALLATION >

### INSTALLATION

#### **CAUTION:**

Keep painted surface on the body or other parts free of clutch fluid. If it spills, wipe up immediately and wash the affected area with water.

1. With the nipple (1) rotated clockwise by 45 degrees, insert clutch master cylinder into the mounting hole. Rotate the clutch master cylinder counterclockwise by 45 degrees (A) as show to secure it. At this time, nipple (1) is in the upward (B) position.

2. Install clutch master cylinder rod end to clutch pedal.

#### **CAUTION:**

Press clutch master cylinder rod end into clutch pedal until it stops.

3. Install reservoir hose to reservoir tank and clutch master cylinder.

#### **CAUTION:**

Rotate reservoir hose with painted mark facing upward.

4. Press down the lock pin into connector of clutch master cylinder until it stops.

5. Install clutch tube into connector of clutch master cylinder until it stops.

6. Fill with clutch fluid and perform air bleeding procedure. Refer to [CL-8. "Refilling"](#) and [CL-9. "Air Bleeding"](#).

7. Installation of the remaining components is in the reverse order of removal.

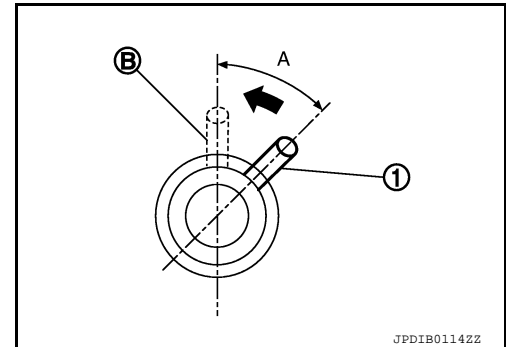

### Inspection and Adjustment

INFOID:000000008768984

#### INSPECTION AFTER INSTALLATION

- Check for fluid leakage and the fluid level. Refer to [CL-7. "Inspection"](#).
- Check the clutch pedal height. Refer to [CL-5. "Inspection and Adjustment"](#).
- Check the clutch interlock switch position. Refer to [CL-5. "Inspection and Adjustment"](#).
- Check the clutch pedal position switch position (if equipped). Refer to [CL-5. "Inspection and Adjustment"](#).

#### ADJUSTMENT AFTER INSTALLATION

- Adjust the clutch interlock switch position. Refer to [CL-5. "Inspection and Adjustment"](#).
- Adjust the clutch pedal position switch position (if equipped). Refer to [CL-5. "Inspection and Adjustment"](#).
- Perform the air bleeding procedure. Refer to [CL-9. "Air Bleeding"](#).

# CLUTCH PIPING

< REMOVAL AND INSTALLATION >

## CLUTCH PIPING

Exploded View

INFOID:000000008768988

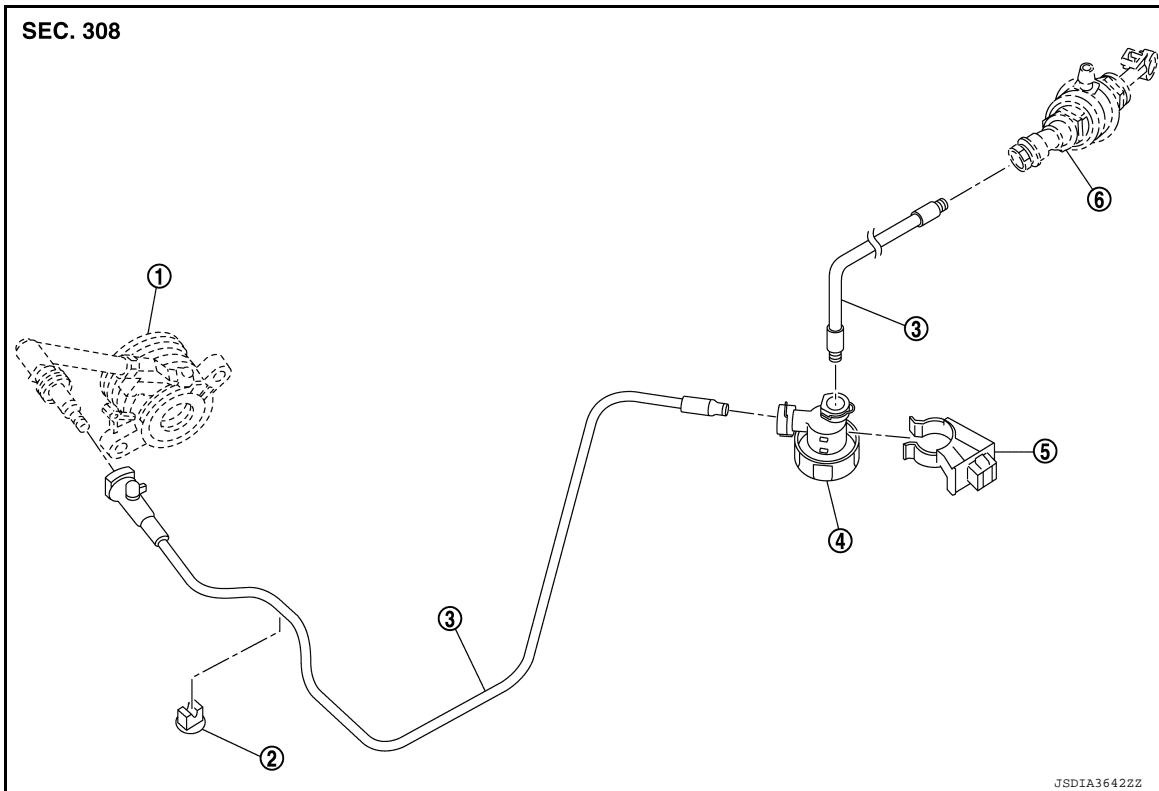

- |                                    |            |                           |
|------------------------------------|------------|---------------------------|
| 1. CSC (Concentric Slave Cylinder) | 2. Clip    | 3. Clutch tube            |
| 4. Clutch damper                   | 5. Bracket | 6. Clutch master cylinder |

## Hydraulic Layout

INFOID:000000008768989

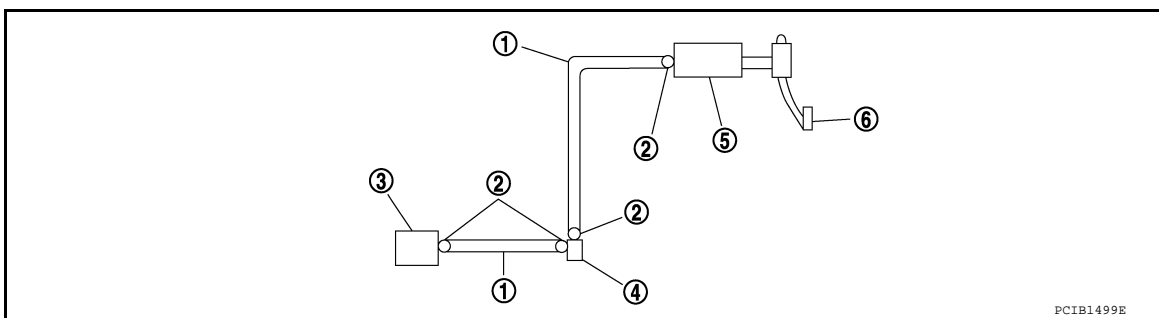

- |                  |                           |                                    |
|------------------|---------------------------|------------------------------------|
| 1. Clutch tube   | 2. Lock pin               | 3. CSC (Concentric Slave Cylinder) |
| 4. Clutch damper | 5. Clutch master cylinder | 6. Clutch pedal                    |

## Removal and Installation

INFOID:000000008768990

### CAUTION:

Keep painted surface on the body or other parts free of clutch fluid. If it spills, wipe up immediately and wash the affected area with water.

### REMOVAL

1. Drain clutch fluid. Refer to [CL-7. "Draining"](#).
2. Press the lock pin into the bleeding connector of the CSC, and then remove clutch tube from CSC.

# CLUTCH PIPING

## < REMOVAL AND INSTALLATION >

3. Pull outward on the lock pins from the connectors of the clutch damper until the pins stop, and then remove clutch tubes from clutch damper. A
4. Pull outward on the lock pin from the connector of the clutch master cylinder until the pin stops, and then remove clutch tube from clutch master cylinder. B

## INSTALLATION

Installation is in the reverse order of removal.

### **CAUTION:**

#### **Do not damage clutch tube.**

- Insert each clutch tube into the CSC bleeding connector, the clutch damper connector, and the clutch master cylinder connector until it contacts the end of each connector. C
- Install each lock pin into the clutch damper connector and the clutch master cylinder connector until it contacts the end of each connector. CL

## Inspection and Adjustment

INFOID:000000008768991

## INSPECTION AFTER REMOVAL

- Check the clutch tube for cracks and damage. If the clutch tube has cracks or damage, replace it with a new one. E
- Check the O-ring of the clutch tube for cracks and damage. If the O-ring of the clutch tube has cracks or damage, replace clutch tube with a new one. F

### **CAUTION:**

#### **Do not reuse O-rings.**

- Check the clutch damper for cracks and damage. If the clutch damper has cracks or damage, replace it with a new one. G

## INSPECTION AFTER INSTALLATION

- Check the fluid leakage and the fluid level. Refer to [CL-7, "Inspection"](#). H
- Check the clutch pedal height. Refer to [CL-5, "Inspection and Adjustment"](#). I

## ADJUSTMENT AFTER INSTALLATION

Perform the air bleeding procedure. Refer to [CL-9, "Air Bleeding"](#). J

J

K

L

M

N

O

P

# CSC (CONCENTRIC SLAVE CYLINDER)

< REMOVAL AND INSTALLATION >

## CSC (CONCENTRIC SLAVE CYLINDER)

Exploded View

INFOID:000000008768992

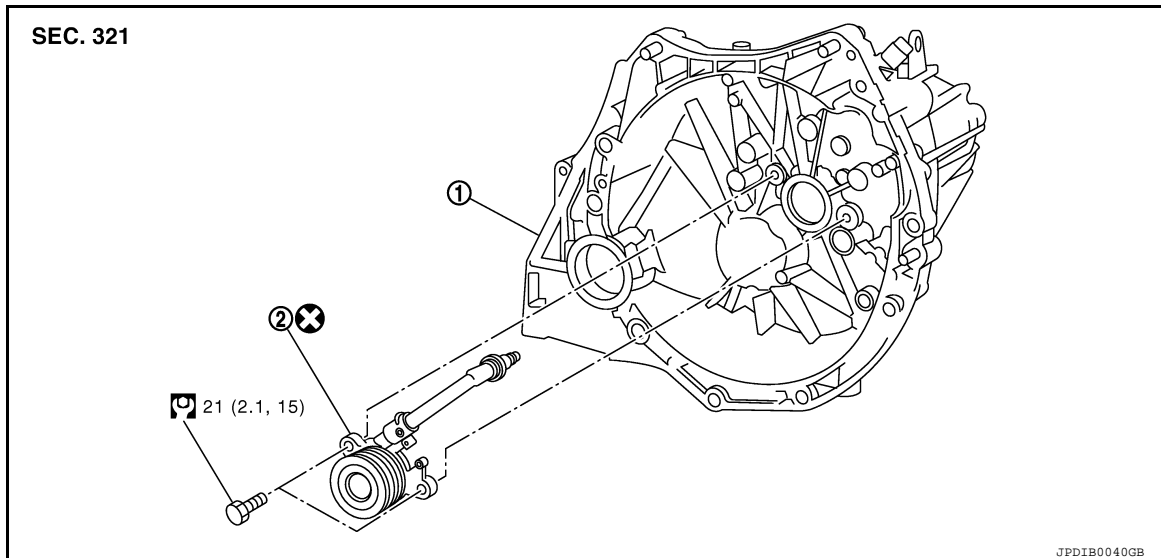

1. Transaxle assembly
2. CSC (Concentric Slave Cylinder)

## Removal and Installation

INFOID:000000008768993

### CAUTION:

- Do not reuse CSC (Concentric Slave Cylinder). The CSC slides back to the original position every time the transaxle assembly is removed. This action may allow dust or contaminants to gather on the sliding parts and damage a seal of CSC causing clutch fluid leakage.
- Do not disassemble CSC.
- Keep painted surface on the body or other parts free of clutch fluid. If clutch fluid spills, wipe up immediately and wash the affected area with water.

### REMOVAL

1. Remove engine and transaxle assembly. Refer to [TM-28, "Removal and Installation"](#).
2. Remove CSC bolts, then remove the CSC from transaxle assembly.

### INSTALLATION

1. Install CSC to transaxle assembly, then tighten CSC bolts to the specified torque.  
**CAUTION:**
  - Do not reuse CSC.
  - Do not install then operate CSC immediately, the piston and stopper of CSC components may fall off.
2. Install engine and transaxle assembly in the reverse order of removal. Refer to [TM-28, "Removal and Installation"](#).

## Inspection and Adjustment

INFOID:000000008768994

### INSPECTION AFTER INSTALLATION

Check for fluid leakage and the fluid level. Refer [CL-7, "Inspection"](#).

### ADJUSTMENT AFTER INSTALLATION

Perform the air bleeding. Refer to [CL-9, "Air Bleeding"](#).



# CLUTCH DISC AND CLUTCH COVER

< REMOVAL AND INSTALLATION >

## CLUTCH DISC AND CLUTCH COVER

Exploded View

INFOID:000000008768995

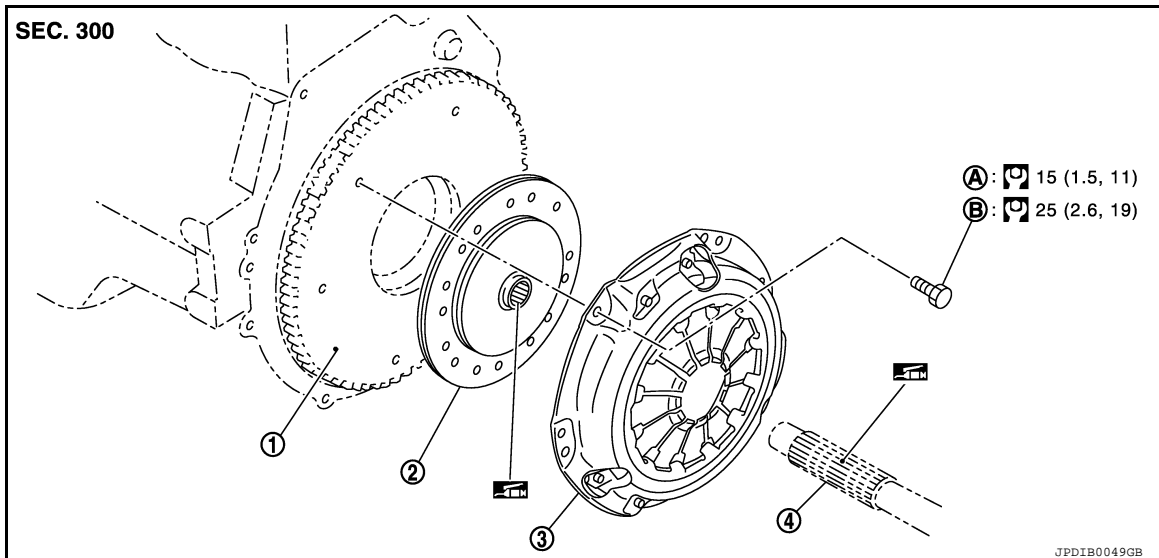

- |                |                |                 |
|----------------|----------------|-----------------|
| 1. Flywheel    | 2. Clutch disc | 3. Clutch cover |
| 4. Input shaft | A. First step  | B. Final step   |

Apply lithium-based grease including molybdenum disulphide.

### Removal and Installation

INFOID:000000008768996

#### CAUTION:

- Do not reuse CSC (Concentric Slave Cylinder). The CSC slides back to the original position every time the transaxle assembly is removed. This action may allow dust or contaminants to gather on the sliding parts and damage a seal of CSC causing clutch fluid leakage. Refer to [CL-16. "Removal and Installation"](#).
- Do not allow any grease to contact the clutch disc facing, pressure plate surface or flywheel surface.
- Do not clean clutch disc using solvent.

#### REMOVAL

1. Remove engine and transaxle assembly. Refer to [TM-28. "Removal and Installation"](#).
2. Loosen clutch cover bolts evenly while holding clutch cover.
3. Remove clutch cover and clutch disc.

#### CAUTION:

**Do not drop clutch disc.**

#### INSTALLATION

1. Clean clutch disc and input shaft splines to remove grease and dust caused by abrasion.
2. Apply recommended grease to clutch disc (1) and input shaft (2) splines area (A).

#### CAUTION:

**Be sure to apply grease to the points specified. Otherwise, noise, poor disengagement, or damage to the clutch may result. Excessive grease may cause slip or shudder. And if it adheres to seal of CSC, it may cause clutch fluid leakage. Wipe off excess grease. Wipe off any grease oozing from the parts.**

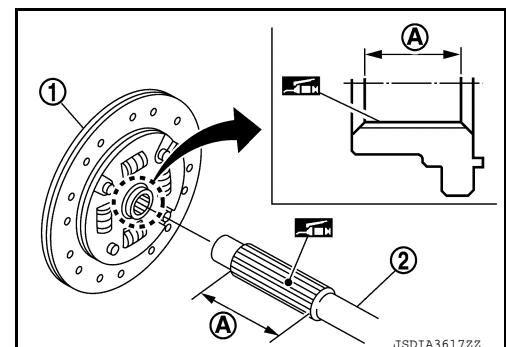

# CLUTCH DISC AND CLUTCH COVER

## < REMOVAL AND INSTALLATION >

3. Install clutch disc, using a suitable tool (A).

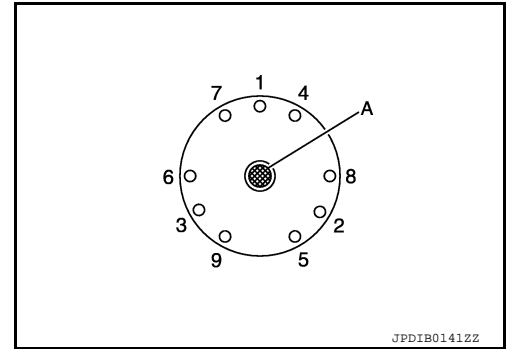

4. Install clutch cover, and then temporarily tighten clutch cover bolts.
5. Tighten clutch cover bolts to the specified torque evenly in two steps in the numerical order as shown.
6. Install engine and transaxle assembly. Refer to [TM-28. "Removal and Installation"](#).

## Inspection

INFOID:000000008768997

### INSPECTION AFTER REMOVAL

#### Clutch Disc

- Measure clutch facing runout. If it is outside the specification, replace clutch disc.

**Runout limit/diameter of the area to be measured** : Refer to [CL-20, "Clutch Disc"](#).

- Measure spline backlash at outer edge of clutch disc. If it is outside the specification, replace clutch disc.

**Maximum allowable spline backlash (at outer edge of disc)** : Refer to [CL-20, "Clutch Disc"](#).

- Measure the depth "A" to clutch disc facing rivet heads, using suitable tool. If it exceeds the allowable wear limit, replace clutch disc.

**Facing wear limit (depth to the rivet head) "A"** : Refer to [CL-20, "Clutch Disc"](#).

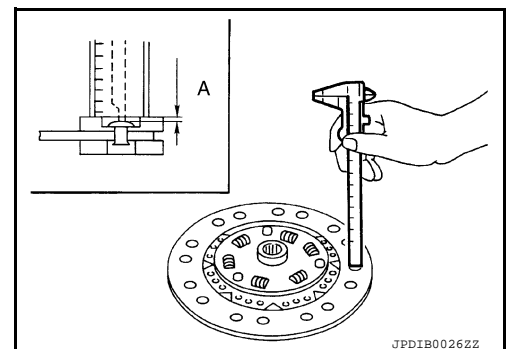
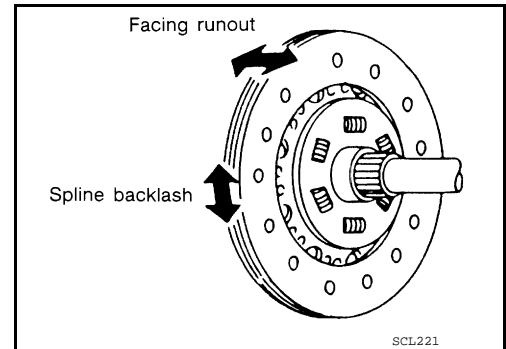

#### Clutch Cover

- Check clutch cover thrust ring for wear or damage. If wear or damage is found, replace clutch cover.

#### NOTE:

- Worn thrust ring will generate a beating noise when tapped at the rivet using suitable tool.
- Broken thrust ring will make a clinking sound when cover is shaken up and down.
- If a trace of burn or discoloration is found on the clutch cover pressure plate to clutch disc contact surface, repair the surface with sandpaper. If surface is damaged or distorted, replace clutch cover.

### INSPECTION AFTER INSTALLATION

#### Clutch Cover

# CLUTCH DISC AND CLUTCH COVER

## < REMOVAL AND INSTALLATION >

Check diaphragm spring lever claws for unevenness with the clutch cover installed on the engine. If they exceed the tolerance, adjust diaphragm spring lever using Tool (A).

**Tolerance for diaphragm spring lever unevenness** : Refer to [CL-20, "Clutch Cover"](#).

**Tool number** : ST20050240 ( — )

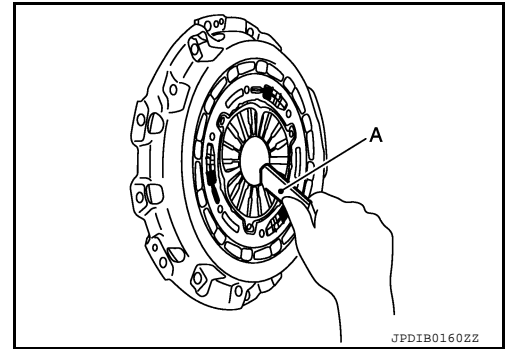

A  
B  
C

CL

E  
F  
G  
H  
I  
J  
K  
L  
M  
N  
O  
P

## SERVICE DATA AND SPECIFICATIONS (SDS)

< SERVICE DATA AND SPECIFICATIONS (SDS)

# SERVICE DATA AND SPECIFICATIONS (SDS)

## SERVICE DATA AND SPECIFICATIONS (SDS)

### General Specifications

INFOID:000000008768998

Unit: mm (in)

Type of clutch control	Hydraulic
Recommended clutch fluid	Refer to <a href="#">MA-12. "Fluids and Lubricants"</a> .

### Clutch Pedal

INFOID:000000008768999

Unit: mm (in)

Clutch pedal height	171.6 – 181.6 (6.76 – 7.15)
Clearance between stopper rubber and clutch interlock switch threaded end while clutch pedal is fully depressed	0.74 – 1.96 (0.0291 – 0.0772)
Clearance between clutch pedal and clutch pedal position switch threaded end while clutch pedal is fully released	0.74 – 1.96 (0.0291 – 0.0772)

### Clutch Disc

INFOID:000000008769000

Unit: mm (in)

Facing size (Outer dia. x Inner dia. x Thickness)	225 x 160 x 3.2 (8.86 x 6.30 x 0.126)
Runout limit/diameter of the area to be measured	1.0 (0.039) / 215 (8.46) dia.
Maximum allowable spline backlash (at outer edge of disc)	1.0 (0.039)
Facing wear limit (depth to the rivet head)	0.3 (0.012)

### Clutch Cover

INFOID:000000008769001

Unit: mm (in)

Tolerance for diaphragm spring lever unevenness	0.7 (0.028) or less
---	---------------------