

A
LU
C
D
E
F
G
H
I
J
K
L
M
N
O
P

SECTION LU

ENGINE LUBRICATION SYSTEM

CONTENTS

<p style="text-align: center;">MRA8DE</p> <p>PRECAUTION 2</p> <p>PRECAUTIONS 2</p> <p style="padding-left: 20px;">Precaution for Supplemental Restraint System (SRS) "AIR BAG" and "SEAT BELT PRE-TENSIONER"2</p> <p style="padding-left: 20px;">Precaution for Liquid Gasket2</p> <p>PREPARATION 4</p> <p>PREPARATION 4</p> <p style="padding-left: 20px;">Special Service Tools4</p> <p style="padding-left: 20px;">Commercial Service Tools4</p> <p>SYSTEM DESCRIPTION 6</p> <p>DESCRIPTION 6</p> <p style="padding-left: 20px;">Engine Lubrication System Schematic6</p> <p>PERIODIC MAINTENANCE 7</p> <p>ENGINE OIL 7</p> <p style="padding-left: 20px;">Inspection7</p> <p style="padding-left: 20px;">Draining8</p> <p style="padding-left: 20px;">Refilling9</p>	<p>OIL FILTER10</p> <p style="padding-left: 20px;">Removal and Installation10</p> <p style="padding-left: 20px;">Inspection11</p> <p>REMOVAL AND INSTALLATION12</p> <p>OIL COOLER12</p> <p style="padding-left: 20px;">Exploded View12</p> <p style="padding-left: 20px;">Removal and Installation13</p> <p style="padding-left: 20px;">Inspection14</p> <p>UNIT DISASSEMBLY AND ASSEMBLY ...15</p> <p>OIL PUMP15</p> <p style="padding-left: 20px;">.....15</p> <p style="padding-left: 20px;">Removal and Installation15</p> <p style="padding-left: 20px;">Inspection16</p> <p>SERVICE DATA AND SPECIFICATIONS (SDS)17</p> <p>SERVICE DATA AND SPECIFICATIONS (SDS)17</p> <p style="padding-left: 20px;">Oil Pressure17</p> <p style="padding-left: 20px;">Oil Capacity17</p>
---	---

PRECAUTIONS

[MRA8DE]

< PRECAUTION >

PRECAUTION

PRECAUTIONS

Precaution for Supplemental Restraint System (SRS) "AIR BAG" and "SEAT BELT PRE-TENSIONER"

INFOID:000000010289411

The Supplemental Restraint System such as "AIR BAG" and "SEAT BELT PRE-TENSIONER", used along with a front seat belt, helps to reduce the risk or severity of injury to the driver and front passenger for certain types of collision. Information necessary to service the system safely is included in the SR and SB section of this Service Manual.

WARNING:

- To avoid rendering the SRS inoperative, which could increase the risk of personal injury or death in the event of a collision which would result in air bag inflation, all maintenance must be performed by an authorized NISSAN/INFINITI dealer.
- Improper maintenance, including incorrect removal and installation of the SRS, can lead to personal injury caused by unintentional activation of the system. For removal of Spiral Cable and Air Bag Module, see the SR section.
- Do not use electrical test equipment on any circuit related to the SRS unless instructed to in this Service Manual. SRS wiring harnesses can be identified by yellow and/or orange harnesses or harness connectors.

PRECAUTIONS WHEN USING POWER TOOLS (AIR OR ELECTRIC) AND HAMMERS

WARNING:

- When working near the Airbag Diagnosis Sensor Unit or other Airbag System sensors with the Ignition ON or engine running, DO NOT use air or electric power tools or strike near the sensor(s) with a hammer. Heavy vibration could activate the sensor(s) and deploy the air bag(s), possibly causing serious injury.
- When using air or electric power tools or hammers, always switch the Ignition OFF, disconnect the battery and wait at least three minutes before performing any service.

Precaution for Liquid Gasket

INFOID:000000010289412

REMOVAL OF LIQUID GASKET

- After removing nuts and bolts, separate the mating surface, using Tool and remove old liquid gasket.

Tool number : KV10111100 (J-37228)

CAUTION:

Be careful not to damage the mating surfaces.

- Tap (1) Tool to insert it, and then slide it (2) by tapping on the side as shown.
- In areas where Tool is difficult to use, use plastic hammer to lightly tap the parts, to remove it.

CAUTION:

Do not damage the mating surfaces.

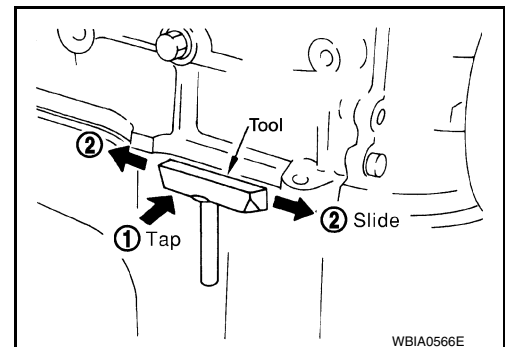

LIQUID GASKET APPLICATION PROCEDURE

1. Remove old liquid gasket adhering to the liquid gasket application surface and the mating surface, using scraper.
 - Remove liquid gasket completely from the groove of the liquid gasket application surface, bolts, and bolt holes.
2. Thoroughly clean the mating surfaces and remove adhering moisture, grease and foreign materials.

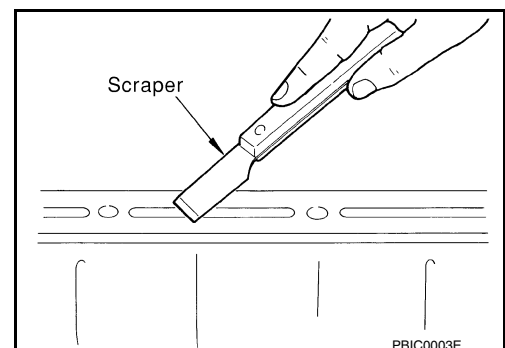

PRECAUTIONS

[MRA8DE]

< PRECAUTION >

3. Attach liquid gasket tube using suitable tool.
Use Genuine RTV Silicone Sealant or equivalent. Refer to GI-21, "Recommended Chemical Products and Sealants".
4. Apply liquid gasket without breaks to the specified location with the specified dimensions.
 - If there is a groove for the liquid gasket application, apply liquid gasket to the groove.

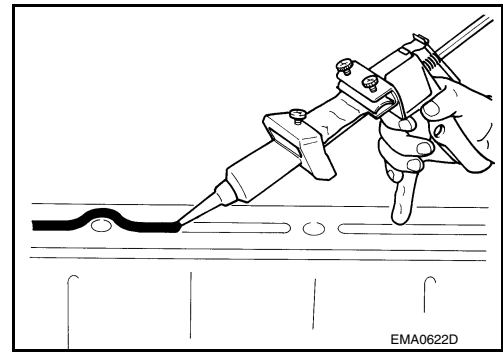

- As for the bolt holes, normally apply liquid gasket inside the holes. Occasionally, it should be applied outside the holes. Make sure to read the text of service manual.
- Within five minutes of liquid gasket application, install the mating component.
- If liquid gasket protrudes, wipe it off immediately.
- Do not retighten nuts or bolts after the installation.
- After 30 minutes or more have passed from the installation, fill engine oil and engine coolant.

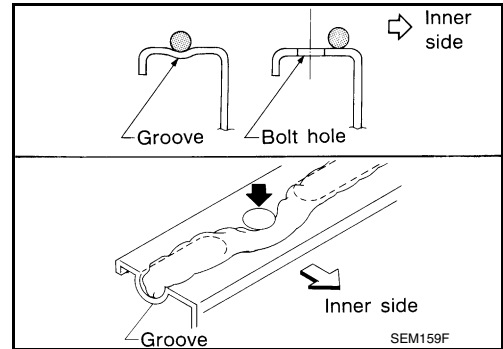

CAUTION:

If there are more specific instructions in the procedures contained in this manual concerning liquid gasket application, observe them.

A
LU
C
D
E
F
G
H
I
J
K
L
M
N
O
P

PREPARATION

< PREPARATION >

[MRA8DE]

PREPARATION

PREPARATION

Special Service Tools

INFOID:000000010289413

The actual shape of the tools may differ from those illustrated here.

Tool number (TechMate No.) Tool name	Description
ST25051001 (J-25695-1) Oil pressure gauge	Measuring oil pressure Maximum measuring range: 2,452 kPa (25 kg-cm², 356 psi)
ST25052000 (J-25695-2) Hose	Adapting oil pressure gauge to upper oil pan
KV10115801 (J-38956) Oil filter wrench	Removing and installing oil filter
KV10111100 (J-37228) Seal cutter	Removing oil pan (lower) etc.

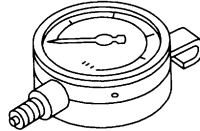

NT050

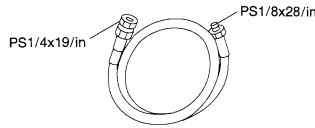

S-NT559

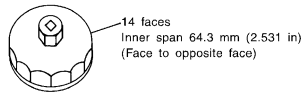

S-NT772

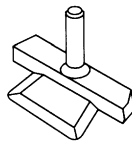

S-NT046

Commercial Service Tools

INFOID:000000010289414

PREPARATION

< PREPARATION >

[MRA8DE]

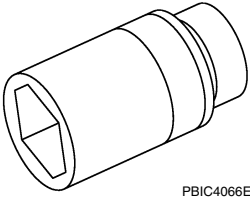
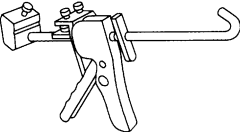
Tool name	Description
<p data-bbox="164 197 293 222">Deep socket</p>  <p data-bbox="829 415 899 432">PBIC4066E</p>	<p data-bbox="1013 197 1451 254">Removing and installing oil pressure sensor 27 mm (1.06 in)</p>
<p data-bbox="164 449 293 474">Tube presser</p>  <p data-bbox="829 663 873 680">NT052</p>	<p data-bbox="1013 449 1344 474">Pressing the tube of liquid gasket</p>

A

LU

C

D

E

F

G

H

I

J

K

L

M

N

O

P

SYSTEM DESCRIPTION

DESCRIPTION

Engine Lubrication System Schematic

INFOID:000000009756253

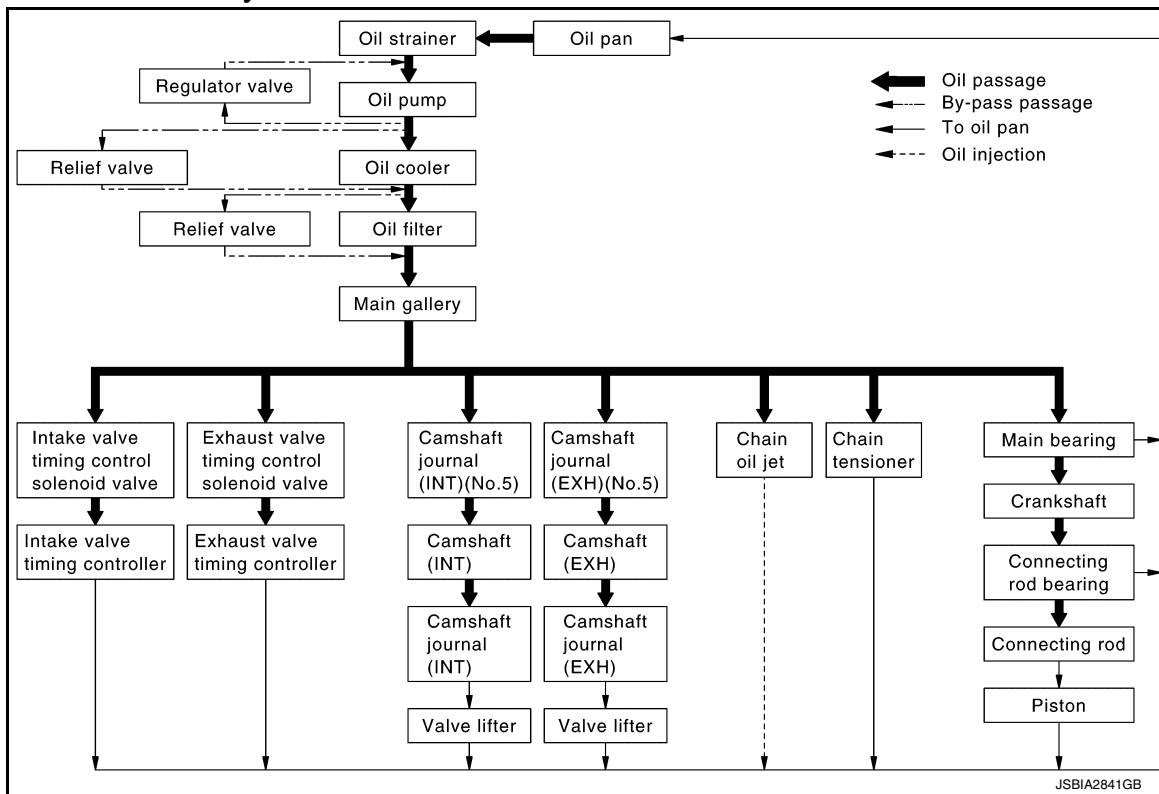

PERIODIC MAINTENANCE

ENGINE OIL

Inspection

INFOID:000000009756254

LU

ENGINE OIL LEVEL

NOTE:

Before starting engine, put vehicle horizontally and check the engine oil level. If engine is already started, stop it and allow 10 minutes before checking.

1. Pull out oil level gauge and wipe it clean.
2. Insert oil level gauge and check that the engine oil level is within the range (A) shown.
3. If engine oil is out of range, adjust it.

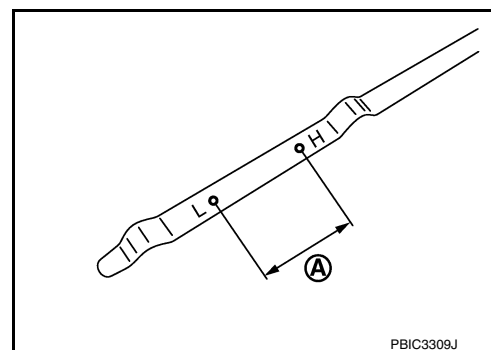

PBIC3309J

ENGINE OIL APPEARANCE

- Check engine oil for white turbidity or heavy contamination.
- If engine oil becomes turbid and white, it is highly probable that it is contaminated with engine coolant. Repair or replace damaged parts.

ENGINE OIL LEAKAGE

Check for engine oil leaks around the following areas.

- Oil cooler
- Oil temperature sensor
- Oil pan (upper and lower)
- Oil pan drain plug
- Oil pressure sensor
- Oil filter
- Valve timing control cover
- Valve timing control solenoid valve (intake and exhaust)
- Front cover
- Mating surface between cylinder head and camshaft bracket
- Mating surface between cylinder block and cylinder head
- Mating surface between camshaft bracket and rocker cover
- Crankshaft oil seals (front and rear)

OIL PRESSURE CHECK

WARNING:

- Be careful not to get burned, as engine oil may be hot.
- When checking engine oil pressure, shift position should be "P" (CVT models) or "N" (M/T models), and apply parking brake securely.

1. Check engine oil level.

ENGINE OIL

[MRA8DE]

< PERIODIC MAINTENANCE >

2. Disconnect harness connector at oil pressure sensor (1), and remove oil pressure sensor using a suitable tool.

(2) : Starter motor

↔ : Engine front

CAUTION:

Do not drop or shock oil pressure sensor.

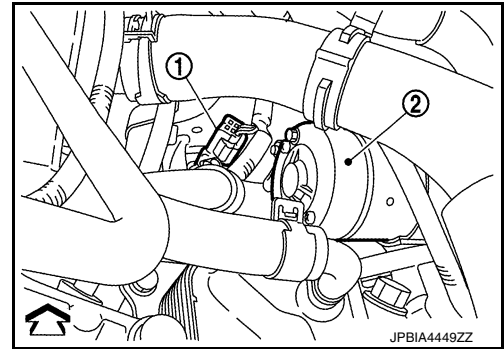

3. Install Tools (A) and (B).

Tool number (A) : ST25051001 (J-25695-1)

Tool number (B) : ST25052000 (J-25695-2)

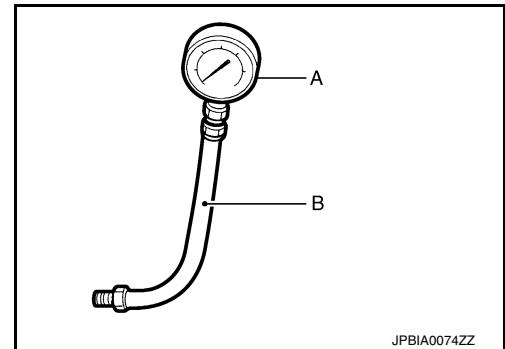

4. Start engine and warm it up to normal operating temperature.
5. Check engine oil pressure with engine running under no-load.

NOTE:

When engine oil temperature is low, engine oil pressure becomes high.

Engine oil pressure : Refer to [LU-17, "Oil Pressure"](#).

CAUTION:

If difference is extreme, check oil passage and oil pump for oil leaks.

6. After the inspections, install oil pressure sensor as follows:
 - a. Remove old liquid gasket adhering to oil pressure sensor and engine.
 - b. Apply liquid gasket and tighten oil pressure sensor to specification.
Use **Genuine RTV Silicon Sealant** or equivalent.

Tightening torque : Refer to [EM-94, "Exploded View"](#).

- c. Check engine oil level.
- d. After warming up engine, check that there are no leaks of engine oil with engine running.

Draining

INFOID:000000009756255

WARNING:

- Be careful not to get burned, as engine oil may be hot.
 - Prolonged and repeated contact with used engine oil may cause skin cancer. Try to avoid direct skin contact with used engine oil. If skin contact is made, wash thoroughly with soap or hand cleaner as soon as possible.
1. Warm up the engine, and check for engine oil leaks from engine components. Refer to [LU-7, "Inspection"](#).
 2. Stop the engine and wait for 10 minutes.
 3. Loosen oil filler cap.
 4. Remove drain plug and then drain engine oil.

Refilling

INFOID:00000009756256

1. Install drain plug with new drain plug washer. Refer to [EM-33, "Exploded View"](#).

CAUTION:

Be sure to clean drain plug and install with new drain plug washer.

Tightening torque : 34.3 N·m (3.5 kg-m, 25 ft-lb).

2. Refill with new engine oil.
 - **Engine oil specification and viscosity:** Refer to [MA-11, "Engine Oil Recommendation"](#).
 - **Engine oil capacity :** Refer to [LU-17, "Oil Capacity"](#).

CAUTION:

 - **The refill capacity depends on the engine oil temperature and drain time. Use these specifications for reference only.**
 - **Always use oil level gauge to determine the proper amount of engine oil in the engine.**
3. Warm up engine and check area around drain plug and oil filter for engine oil leaks.
4. Stop engine and wait for 10 minutes.
5. Check the engine oil level. Refer to [LU-7, "Inspection"](#).

A

LU

C

D

E

F

G

H

I

J

K

L

M

N

O

P

OIL FILTER

< PERIODIC MAINTENANCE >

[MRA8DE]

OIL FILTER

Removal and Installation

INFOID:000000009756257

REMOVAL

1. Remove engine under cover. Refer to [EXT-16, "Exploded View"](#).
2. Drain engine oil. Refer to [LU-8, "Draining"](#).
3. Remove the oil filter using Tool (A) as shown.



: Front

Tool number : KV10115801 (J-38956)

WARNING:

Be careful not to burn yourself, as the engine oil may be hot.

CAUTION:

- When removing, prepare a shop cloth to absorb any oil leaks or spills.
 - Do not allow engine oil to adhere to the drive belts.
 - Completely wipe off any oil that adheres to the engine and the vehicle.
-
- The oil filter is provided with a relief valve. Use a Genuine NISSAN oil filter or equivalent.

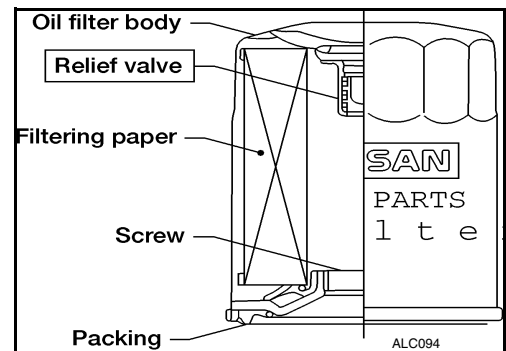
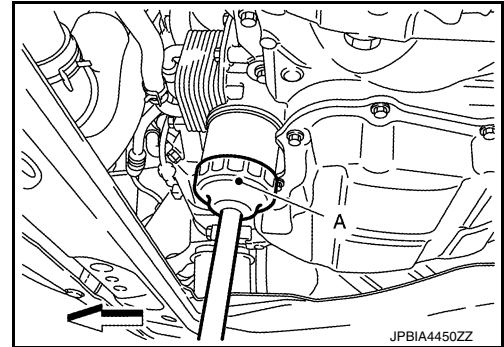

INSTALLATION

1. Remove foreign materials adhering to the oil filter installation surface.
2. Apply new engine oil to the oil seal contact surface of new oil filter.

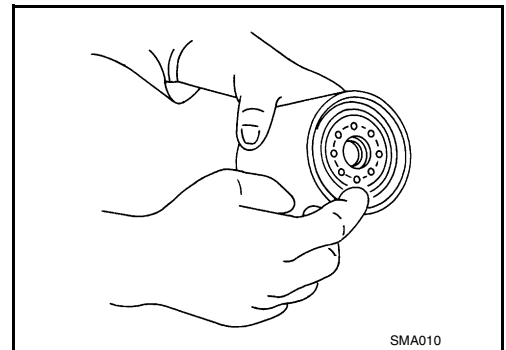

3. Screw oil filter manually until it touches the installation surface, then tighten it by 2/3 turn (A), or tighten to specification.

Oil filter : 18.0 N·m (1.8 kg·m, 13 ft·lb)

Tool number : KV10115801 (J-38956)

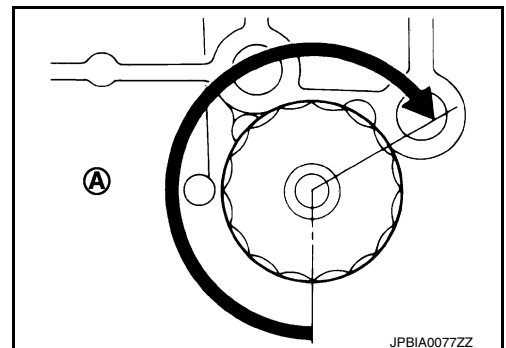

OIL FILTER

[MRA8DE]

< PERIODIC MAINTENANCE >

4. Refill engine with new engine oil. Refer to [LU-9, "Refilling"](#).
5. Install engine under cover. Refer to [EXT-16, "Exploded View"](#).

A

Inspection

INFOID:000000009756258

LU

INSPECTION AFTER INSTALLATION

1. Check the engine oil level. Refer to [LU-7, "Inspection"](#).
2. Start the engine, and check that there are no leaks of engine oil.
3. Stop the engine and wait for 10 minutes.
4. Check the engine oil level, and adjust the level. Refer to [LU-7, "Inspection"](#).

C

D

E

F

G

H

I

J

K

L

M

N

O

P

OIL COOLER

< REMOVAL AND INSTALLATION >

[MRA8DE]

REMOVAL AND INSTALLATION

OIL COOLER

Exploded View

INFOID:000000009756259

M/T models

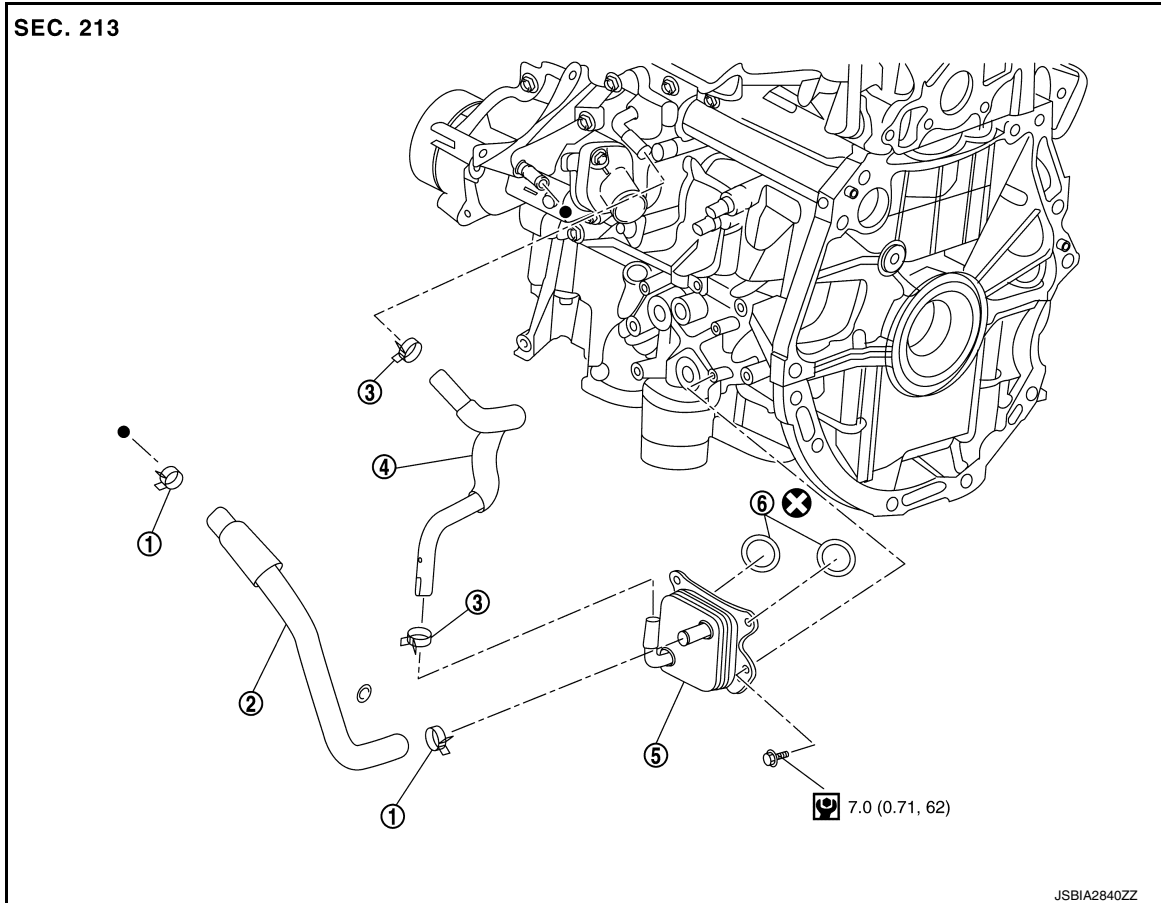

- | | | |
|---------------|---------------|------------|
| 1. Clamp | 2. Water hose | 3. Clamp |
| 4. Water hose | 5. Oil cooler | 6. O-rings |

OIL COOLER

< REMOVAL AND INSTALLATION >

[MRA8DE]

CVT models

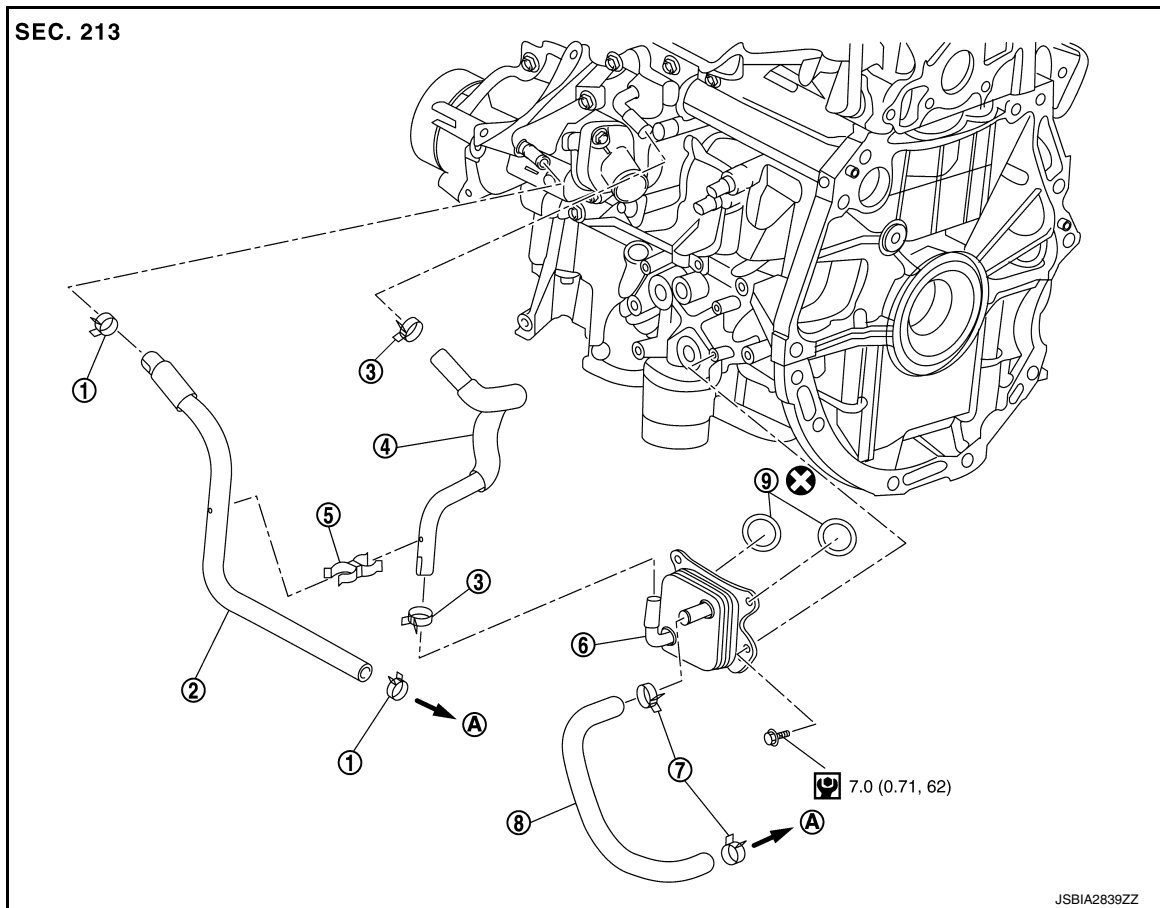

- | | | |
|----------------------|--------------------|---------------|
| 1. Clamp | 2. Water hose | 3. Clamp |
| 4. Water hose | 5. Water hose clip | 6. Oil cooler |
| 7. Clamp | 8. Water hose | 9. O-rings |
| A. To CVT oil warmer | | |

Removal and Installation

INFOID:000000009756260

REMOVAL

1. Remove engine under cover. Refer to [EXT-16. "Exploded View"](#).
2. Drain engine coolant. Refer to [CO-12. "Changing Engine Coolant"](#).
CAUTION:
Perform when engine is cold.
3. Remove water hoses.
4. Remove bolts, oil cooler and O-rings.
CAUTION:
 - Be careful not to get burned when engine and engine oil may be hot.
 - When removing, prepare a shop cloth to absorb any engine oil leaks or spills.
 - Completely wipe off any engine oil that adheres to engine and vehicle.

INSTALLATION

Installation is in the reverse order of removal.

CAUTION:

Do not reuse O-rings.

NOTE:

OIL COOLER

[MRA8DE]

< REMOVAL AND INSTALLATION >

Tighten the oil cooler bolts in order as shown to specification.

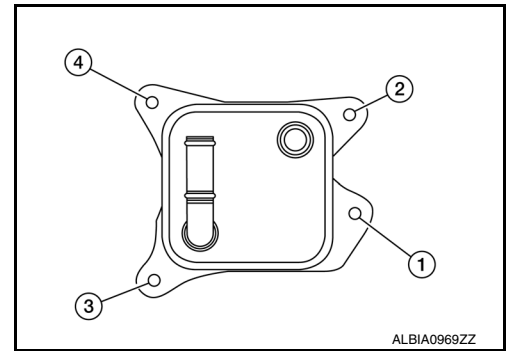

INFOID:000000009756261

Inspection

INSPECTION AFTER REMOVAL

Oil Cooler

Check oil cooler for cracks. Check oil cooler for clogging by blowing through engine coolant inlet. If necessary, replace oil cooler assembly.

INSPECTION AFTER INSTALLATION

1. Check the engine oil level and the engine coolant level and add engine oil and engine coolant. Refer to [LU-7. "Inspection"](#) and [CO-11. "System Inspection"](#).
2. Start the engine, and check that there are no leaks of engine oil or engine coolant.
3. Stop the engine and wait for 10 minutes.
4. Check the engine oil level and the engine coolant level again. Refer to [LU-7. "Inspection"](#) and [CO-11. "System Inspection"](#).

OIL PUMP

< UNIT DISASSEMBLY AND ASSEMBLY >

[MRA8DE]

UNIT DISASSEMBLY AND ASSEMBLY

OIL PUMP

INFOID:000000009756263

A

LU

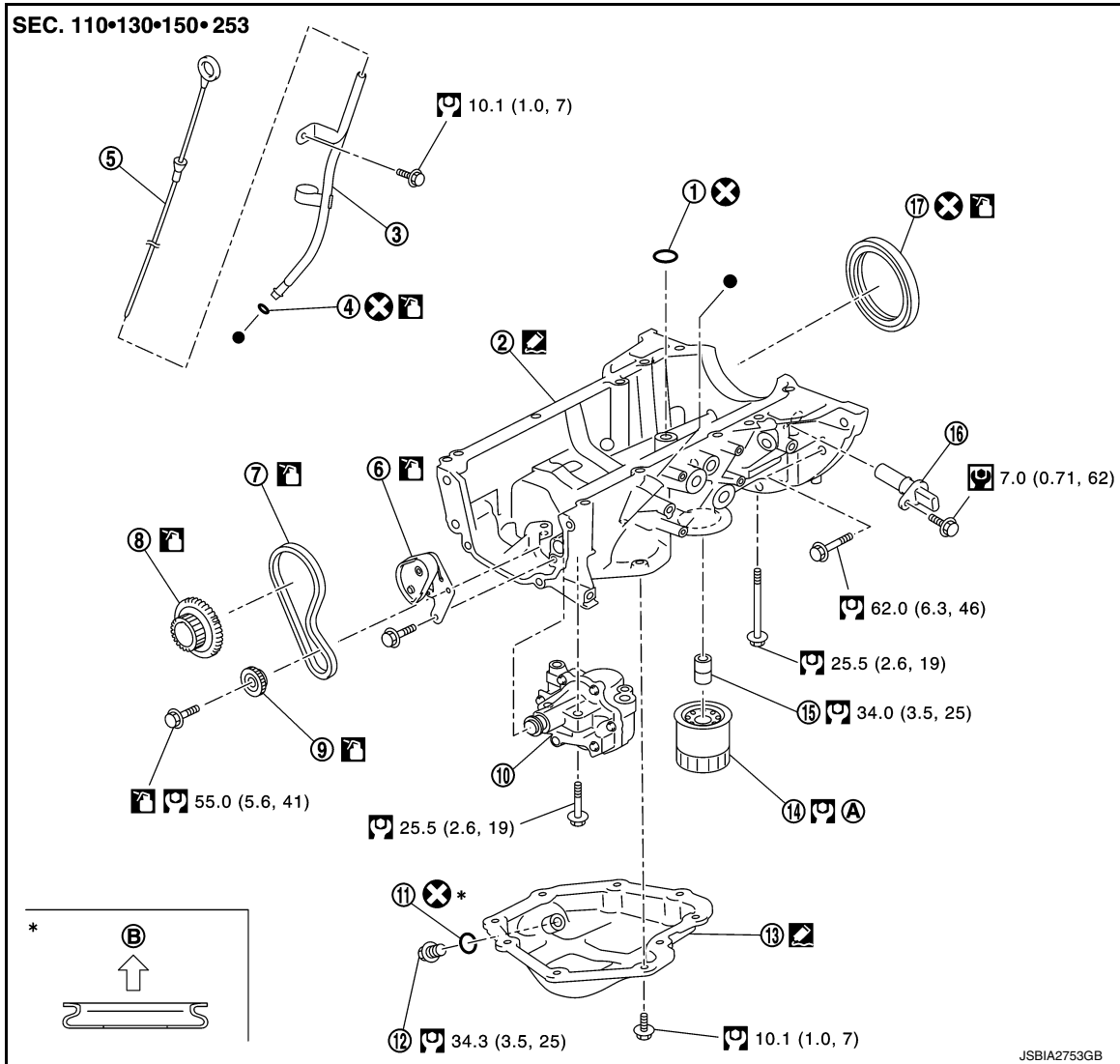

C

D

E

F

G

H

I

J

K

L

M

N

O

P

- | | | |
|--|------------------------|-----------------------------|
| 1. O-ring | 2. Oil pan (upper) | 3. Oil level gauge guide |
| 4. O-ring | 5. Oil level gauge | 6. Oil pump chain tensioner |
| 7. Oil pump drive chain | 8. Crankshaft sprocket | 9. Oil pump sprocket |
| 10. Oil pump | 11. Drain plug washer | 12. Drain plug |
| 13. Oil pan (lower) | 14. Oil filter | 15. Connector bolt |
| 16. Crankshaft position sensor | 17. Rear oil seal | |
| A. Refer to LU-10 . "Removal and Installation" | B. Oil pan side | |

Removal and Installation

INFOID:000000009756263

REMOVAL

1. Remove engine under cover. Refer to [EXT-16](#). "Exploded View".
2. Remove air cleaner and air duct. Refer to [EM-25](#). "Removal and Installation".

OIL PUMP

[MRA8DE]

< UNIT DISASSEMBLY AND ASSEMBLY >

3. Remove fender protector. Refer to [EXT-28. "FENDER PROTECTOR : Removal and Installation - Front Fender Protector"](#).
4. Remove timing chain. Refer to [EM-49. "Removal and Installation"](#).
5. Remove oil pump.
 - Loosen bolts in reverse order as shown.

- (1) : Oil pump
- (2) : Oil pan (upper)
- ⇐ : Engine front

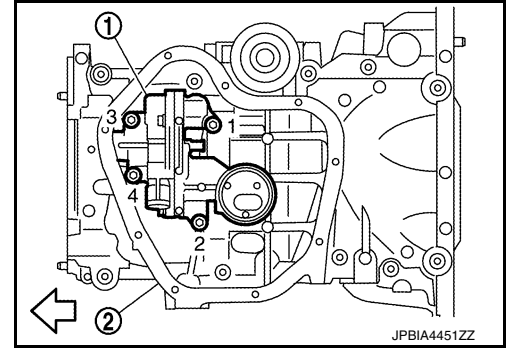

INSTALLATION

CAUTION:

Do not reuse O-rings or washers.

Installation is in the reverse order of removal.

Oil Pump

- Tighten bolts in numerical order as shown.

- (1) : Oil pump
- (2) : Oil pan (upper)
- ⇐ : Engine front

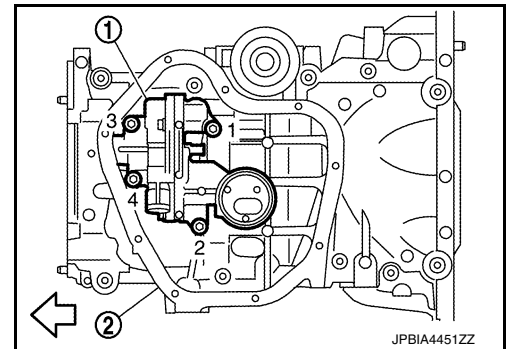

INFOID:000000009756264

Inspection

INSPECTION AFTER INSTALLATION

1. Check the engine oil level. Refer to [LU-7. "Inspection"](#).
2. Start the engine, and check that there are no leaks of engine oil.
3. Stop the engine and wait for 10 minutes.
4. Check the engine oil level, and adjust the level. Refer to [LU-7. "Inspection"](#).

SERVICE DATA AND SPECIFICATIONS (SDS)

< SERVICE DATA AND SPECIFICATIONS (SDS)

[MRA8DE]

SERVICE DATA AND SPECIFICATIONS (SDS)

SERVICE DATA AND SPECIFICATIONS (SDS)

Oil Pressure

INFOID:000000009756265

LU

Unit: kPa (kg/cm², psi)

Engine speed	Approximate discharge oil pressure*
Idle speed	71 (0.72, 10.3)
2,000 rpm	200 (2.04, 29.0)

*: Engine oil temperature at 80°C (176°F)

Oil Capacity

INFOID:000000009756266

Unit: ℓ (US qt, Imp qt)

Drain and refill	With oil filter change	4.0 (4-1/4, 3-1/2)
	Without oil filter change	3.8 (4, 3-3/8)
Dry engine (Overhaul)		4.8 (5-1/8, 4-1/4)