

A
B
C

SECTION **ST**

STEERING SYSTEM

CONTENTS

PRECAUTION	2	REMOVAL AND INSTALLATION	10	F
PRECAUTIONS	2	STEERING WHEEL	10	
Precaution for Supplemental Restraint System (SRS) "AIR BAG" and "SEAT BELT PRE-TENSIONER"	2	Exploded View	10	
Service Notice or Precautions for Steering System	2	Removal and Installation	10	ST
PREPARATION	3	STEERING COLUMN	12	
PREPARATION	3	Exploded View	12	H
Special Service Tools	3	Removal and Installation	12	
Commercial Service Tools	4	STEERING GEAR AND LINKAGE	14	I
BASIC INSPECTION	5	Exploded View	14	
STEERING WHEEL	5	Removal and Installation	14	
Inspection	5	UNIT DISASSEMBLY AND ASSEMBLY ...	16	J
STEERING COLUMN	7	STEERING GEAR AND LINKAGE	16	
Inspection	7	Exploded View	16	K
STEERING GEAR AND LINKAGE	8	Disassembly and Assembly	16	
Inspection	8	SERVICE DATA AND SPECIFICATIONS (SDS)	18	L
SYMPTOM DIAGNOSIS	9	SERVICE DATA AND SPECIFICATIONS (SDS)	18	M
NOISE, VIBRATION AND HARSHNESS (NVH) TROUBLESHOOTING	9	Steering Wheel	18	
NVH Troubleshooting Chart	9	Steering Angle	18	
		Steering Column	18	N
		Power Steering Gear	19	

PRECAUTIONS

< PRECAUTION >

PRECAUTION

PRECAUTIONS

Precaution for Supplemental Restraint System (SRS) "AIR BAG" and "SEAT BELT PRE-TENSIONER"

INFOID:000000010305300

The Supplemental Restraint System such as "AIR BAG" and "SEAT BELT PRE-TENSIONER", used along with a front seat belt, helps to reduce the risk or severity of injury to the driver and front passenger for certain types of collision. Information necessary to service the system safely is included in the SR and SB section of this Service Manual.

WARNING:

- To avoid rendering the SRS inoperative, which could increase the risk of personal injury or death in the event of a collision which would result in air bag inflation, all maintenance must be performed by an authorized NISSAN/INFINITI dealer.
- Improper maintenance, including incorrect removal and installation of the SRS, can lead to personal injury caused by unintentional activation of the system. For removal of Spiral Cable and Air Bag Module, see the SR section.
- Do not use electrical test equipment on any circuit related to the SRS unless instructed to in this Service Manual. SRS wiring harnesses can be identified by yellow and/or orange harnesses or harness connectors.

PRECAUTIONS WHEN USING POWER TOOLS (AIR OR ELECTRIC) AND HAMMERS

WARNING:

- When working near the Airbag Diagnosis Sensor Unit or other Airbag System sensors with the Ignition ON or engine running, DO NOT use air or electric power tools or strike near the sensor(s) with a hammer. Heavy vibration could activate the sensor(s) and deploy the air bag(s), possibly causing serious injury.
- When using air or electric power tools or hammers, always switch the Ignition OFF, disconnect the battery and wait at least three minutes before performing any service.

Service Notice or Precautions for Steering System

INFOID:000000009759128

- In case of removing steering gear assembly, make the final tightening with grounded and unloaded vehicle condition, and then check wheel alignment.
- Observe the following precautions when disassembling.
 - Before disassembly, thoroughly clean the outside of the unit.
 - Disassembly should be done in a clean work area. It is important to prevent the internal parts from becoming contaminated by dirt or other foreign matter.
 - For easier and proper assembly, place disassembled parts in order on a parts rack.
 - Use nylon cloth or paper towels to clean the parts; common shop rags can leave lint that might interfere with their operation.
 - Do not reuse non-reusable parts.
 - Before assembling, apply the specified grease to the directed parts.
- During quick steering, rasping noise may be heard from around the steering wheel. This is not a malfunction. The noise is an operating noise of the EPS system under normal conditions. If the rasping noise occurs during slow steering, this may not be an operating noise of the system. In this case, it is necessary to find out the location of the noise and repair, if necessary.
- Do not repeat static steering. (Motor and EPS control unit could be heated.)

PREPARATION

< PREPARATION >

PREPARATION

PREPARATION

Special Service Tools

INFOID:000000009759130

The actual shape of the tools may differ from those illustrated here.

Tool number (TechMate No.) Tool name	Description
ST3127S000 (See J-25765-A) Preload gauge 1. GG9103000 (J-25765-A) Torque wrench 2. HT62940000 (—) Socket adapter 3. HT62900000 (—) Socket adapter	Inspection of rotating torque for ball joint
KV40107300 (—) Boot Band crimping tool	Installing boot clamp (large diameter)
— (J-44372) Spring gauge	Measure steering wheel turning force or rack sliding force
HT72520000 (J-25730-A) Ball joint remover	Removing ball joint

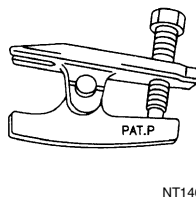
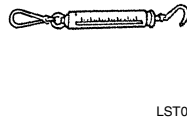
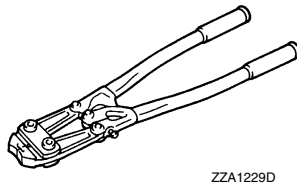
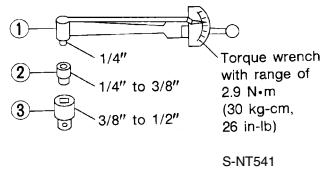



A
B
C
D
E
F
ST
H
I
J
K
L
M
N
O
P

PREPARATION

< PREPARATION >

Commercial Service Tools

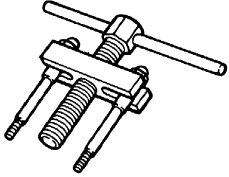
INFOID:000000009759131

Tool name	Description
Steering wheel puller  ZZA0819D	Removing steering wheel
Power tool  PIIB1407E	Loosening nuts, screws and bolts

STEERING WHEEL

< BASIC INSPECTION >

BASIC INSPECTION

STEERING WHEEL

Inspection

INFOID:000000009759132

CONDITION OF INSTALLATION

- Check installation condition of power steering gear assembly, front suspension, front drive shaft and steering column.
- Check if movement exists when steering wheel is moved up and down, to the left and right and to the axial direction.

Steering wheel axial end play

: Refer to [ST-18, "Steering Wheel"](#).

- Verify that the power steering gear nuts are tightened to specification. Refer to [ST-10, "Exploded View"](#).

STEERING WHEEL PLAY

1. Turn tires straight ahead, start engine, then turn steering wheel to the left and right lightly. Measure steering wheel movement on the outer circumference of the steering wheel when it is turned to the point where tires start moving.

Steering wheel play

: Refer to [ST-18, "Steering Wheel"](#).

NEUTRAL POSITION ON STEERING WHEEL

- Check neutral position on steering wheel after confirming that front wheel alignment is correct. Refer to [FSU-23, "Wheel Alignment \(Unladen*1\)"](#).

1. Turn tires straight ahead, check if steering wheel is in the neutral position.
2. If it is not in the neutral position, remove steering wheel and reinstall it correctly.
3. If the neutral position cannot be attained by repositioning the steering wheel two teeth or less on steering stem, loosen outer socket lock nuts of power steering gear outer sockets, then adjust outer sockets by the same amount in the opposite direction.

STEERING WHEEL TURNING FORCE

1. Park vehicle on a level and dry surface, set parking brake.
2. Tires need to be inflated to normal pressure. Refer to [WT-54, "Tire Air Pressure"](#).
3. Start engine.
4. Check steering wheel turning force using Tool when steering wheel has been turned 360° from the neutral position.

Tool number : — (J-44372)

Steering wheel turning force : Refer to [ST-18, "Steering Wheel"](#).

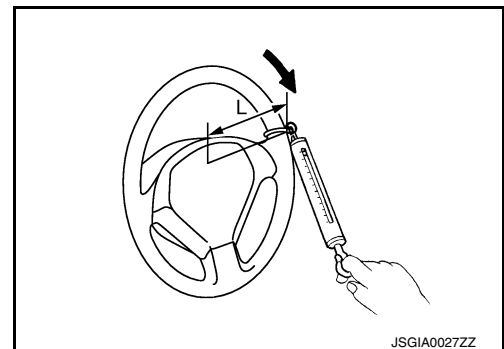

FRONT WHEEL TURNING ANGLE

1. Perform toe-in inspection. Refer to [FSU-6, "Inspection"](#).

CAUTION:

Perform front wheel turning angle inspection, after toe-in inspection.

STEERING WHEEL

< BASIC INSPECTION >

- Place front wheels on turning radius gauges and rear wheels on stands, so that vehicle can be level.
- Check the maximum inner and outer wheel turning angles for (RH/LH) road wheels.

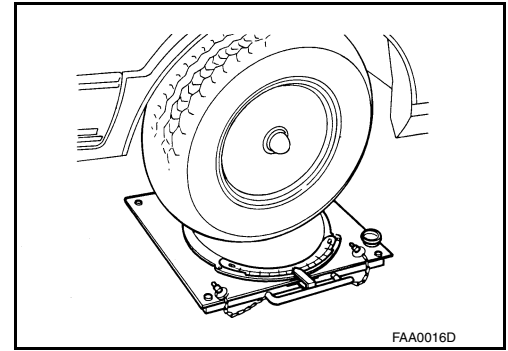

- With the engine at idle, turn steering wheel from full left stop to full right stop and measure the turning angles.

Inner wheel (Angle: A) : Refer to [ST-18, "Steering Angle"](#).

Outer wheel (Angle: B) : Refer to [ST-18, "Steering Angle"](#).

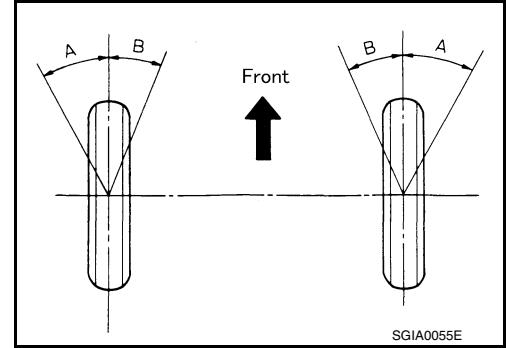

- Check the following items when turning angle is out of the standard.
 - Check rack stroke (L).

(L) : Refer to [ST-19, "Power Steering Gear"](#).

- If rack stroke is out of specification, replace steering gear assembly.
- Steering angles are not adjustable. Check steering gear assembly, steering column assembly, and front suspension components for wear or damage if any of the turning angles are different from the specified value. Replace any of them, if any non-standard condition exists.

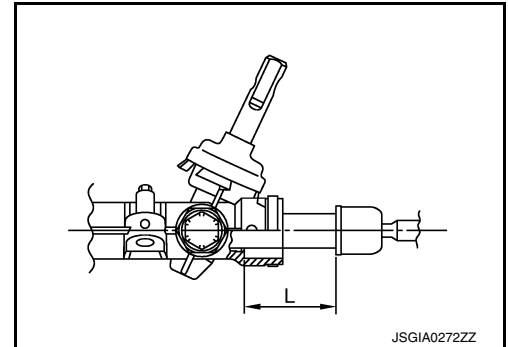

STEERING COLUMN

< BASIC INSPECTION >

STEERING COLUMN

Inspection

INFOID:000000009759133

STEERING COLUMN ASSEMBLY

- Check each part of steering column assembly for damage or other malfunctions. Replace entire steering column assembly if any parts are damaged.
- Measure steering column rotating torque using Tool. Replace steering column assembly if outside the specification.

Tool number (A) : **ST3127S000 (J-25765-A)**

Rotating torque : Refer to [ST-18, "Steering Column"](#).

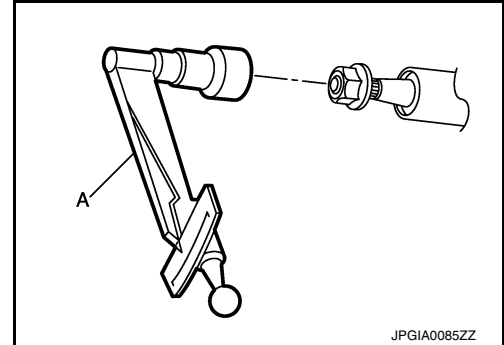

- Measure the length (L) as shown if vehicle has been involved in a minor collision. Replace steering column assembly if outside the specifications.

Steering column length (L) : Refer to [ST-18, "Steering Column"](#).

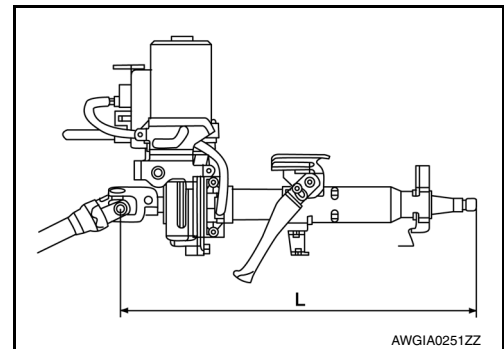

- Check each part of steering column assembly for damage or other malfunctions. Replace if there are any abnormal conditions.
- Check the steering wheel play, neutral position steering wheel, steering wheel turning force, and front wheel turning angle. Refer to [ST-5, "Inspection"](#)
- Check tilt mechanism operating range and telescopic mechanism operating range as shown.

Tilt mechanism operating range (A) : Refer to [ST-18, "Steering Column"](#).

Telescopic mechanism operating range (B) : Refer to [ST-18, "Steering Column"](#).

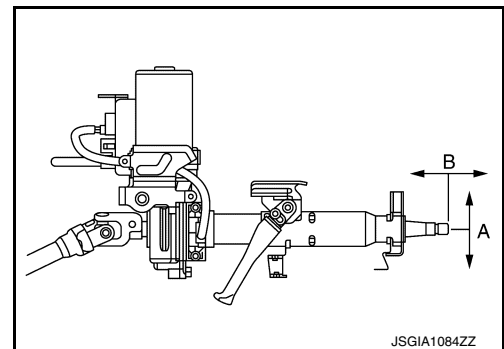

STEERING GEAR AND LINKAGE

< BASIC INSPECTION >

STEERING GEAR AND LINKAGE

Inspection

INFOID:000000009759134

INSPECTION AFTER DISASSEMBLY

BOOT

- Check boot for cracks. Replace if any damage is found.

STEERING GEAR ASSEMBLY HOUSING

- Check steering gear assembly housing for damage and scratches. Replace if there are any abnormal conditions.

OUTER SOCKET AND INNER SOCKET

- Ball joint swinging torque
- Hook a spring balance to the ball stud and inner socket measuring point (*) and pull the spring balance. Make sure that the spring balance reads the specified value when ball stud and inner socket start to move. Replace outer socket and inner socket if they are outside the specification.

Tool number : — (J-44372)

Swinging torque : Refer to [ST-19, "Power Steering Gear"](#).

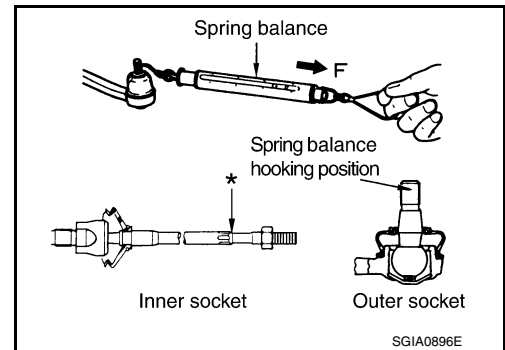

- Ball joint rotating torque
- Make sure that the reading is within the following specified range using Tool. Replace outer socket if the reading is outside the specification.

Tool number (A) : ST3127S000 (J-25765-A)

Rotating torque : Refer to [ST-19, "Power Steering Gear"](#).

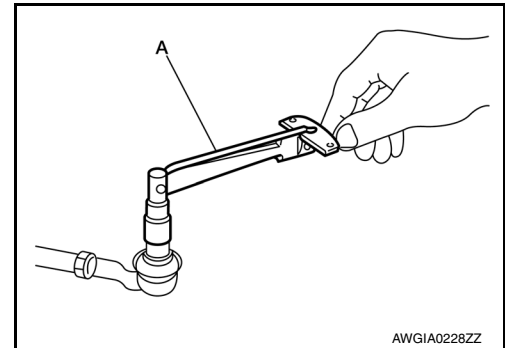

- Ball joint axial end play
- Apply an axial load of 490 N (50 kg, 110 lb.) to ball stud. Measuring the amount of stud movement using a suitable tool, make sure that the value is within specification. Replace outer socket (A) and inner socket (B) if the measured value is outside specification.

Axial end play : Refer to [ST-19, "Power Steering Gear"](#).

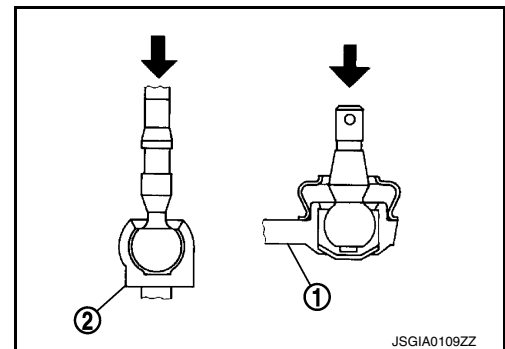

INSPECTION AFTER INSTALLATION

- Check if steering wheel turns smoothly when it is turned several times fully to the end of the left and right.
- Check the steering wheel play, neutral position steering wheel, steering wheel turning force, and front wheel turning angle.
- Steering wheel play: Refer to [ST-5, "Inspection"](#).
- Neutral position steering wheel, steering wheel turning force, and front wheel turning angle: Refer to [ST-5, "Inspection"](#).

NOISE, VIBRATION AND HARSHNESS (NVH) TROUBLESHOOTING

< SYMPTOM DIAGNOSIS >

SYMPTOM DIAGNOSIS

NOISE, VIBRATION AND HARSHNESS (NVH) TROUBLESHOOTING

NVH Troubleshooting Chart

INFOID:000000009759135

Use the chart below to find the cause of the symptom. If necessary, repair or replace these parts.

Symptom	Steering	Possible cause and SUSPECTED PARTS																Reference													
		Noise	Shake	Vibration	Shimmy	Shudder	Outer/inner socket ball joint swinging torque	Outer/inner socket ball joint rotating torque	Outer/inner socket ball joint end play	Steering wheel play	Improper steering wheel	Improper installation or looseness of tilt lock lever	Mounting looseness	Steering column deformation or damage	Improper installation or looseness of steering column	Steering linkage looseness	AXLE and SUSPENSION		TIRE	ROAD WHEEL	DRIVE SHAFT	BRAKE									
		x	x	x	x									x																	ST-8, "Inspection"
																															ST-8, "Inspection"
																															ST-8, "Inspection"
																															ST-5, "Inspection"
							x																								—
							x																								—
																															ST-14, "Exploded View"
																															ST-7, "Inspection"
																															ST-12, "Exploded View"
																															ST-14, "Exploded View"
																															FAX-5, "NVH Troubleshooting Chart", RAX-4, "NVH Troubleshooting Chart" FSU-4, "NVH Troubleshooting Chart", RSU-4, "NVH Troubleshooting Chart"
																															WT-45, "NVH Troubleshooting Chart"
																															WT-45, "NVH Troubleshooting Chart"
																															FAX-5, "NVH Troubleshooting Chart"
																															BR-7, "NVH Troubleshooting Chart"

x: Applicable

A
B
C
D
E
F
G
H
I
J
K
L
M
N
O
P

STEERING WHEEL

< REMOVAL AND INSTALLATION >

REMOVAL AND INSTALLATION

STEERING WHEEL

Exploded View

INFOID:000000009759136

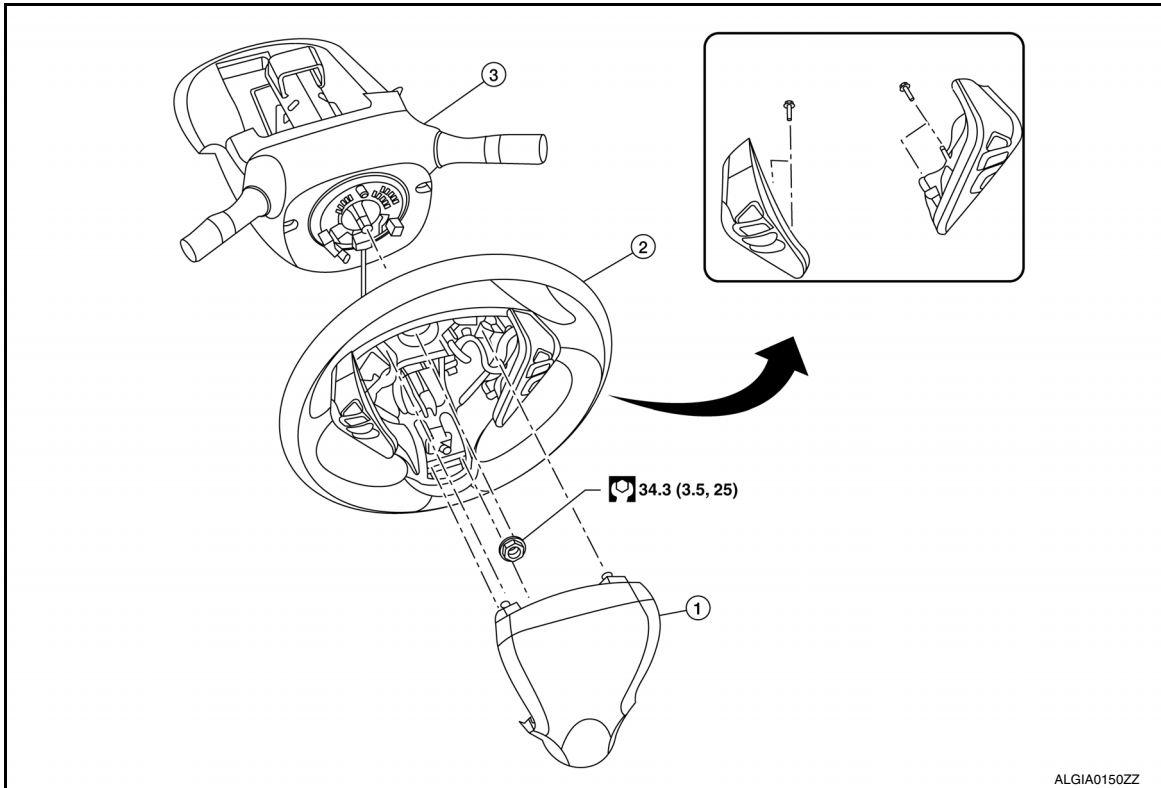

1. Driver air bag module

2. Steering wheel

3. Steering column assembly

Removal and Installation

INFOID:000000009759137

REMOVAL

NOTE:

When reconnecting spiral cable, fix cable with a tape so that fixing case and rotating part keep aligned. This will omit neutral position alignment procedure during spiral cable installation.

1. Set steering wheel to the straight-ahead position.
2. Remove driver air bag module. Refer to [SR-12. "Removal and Installation"](#).
3. Disconnect harness connectors from clipping locations.
4. Remove steering wheel lock nut.
5. Remove steering wheel using suitable tool (A).

NOTE:

Put paint marks on the steering wheel and the column shaft head for supporting accurate positioning during the installation procedure.

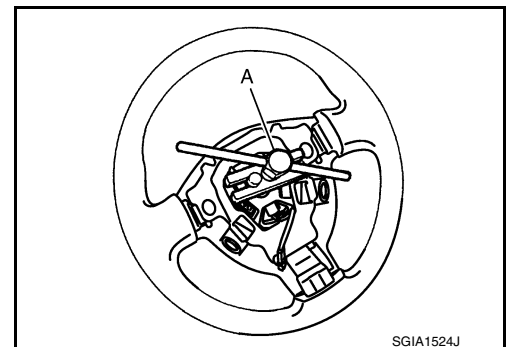

INSTALLATION

STEERING WHEEL

< REMOVAL AND INSTALLATION >

Installation is in the reverse order of removal.

- Check the spiral cable neutral position after replacing or rotating spiral cable. Refer to [SR-16, "Removal and Installation"](#).

CAUTION:

- **Do not twist spiral cable excessively after it becomes tight. (Twisting may cause the cable to be torn off.)**
- **Do not reuse steering wheel lock nut.**

A

B

C

D

E

F

ST

H

I

J

K

L

M

N

O

P

STEERING COLUMN

< REMOVAL AND INSTALLATION >

STEERING COLUMN

Exploded View

INFOID:000000009759138

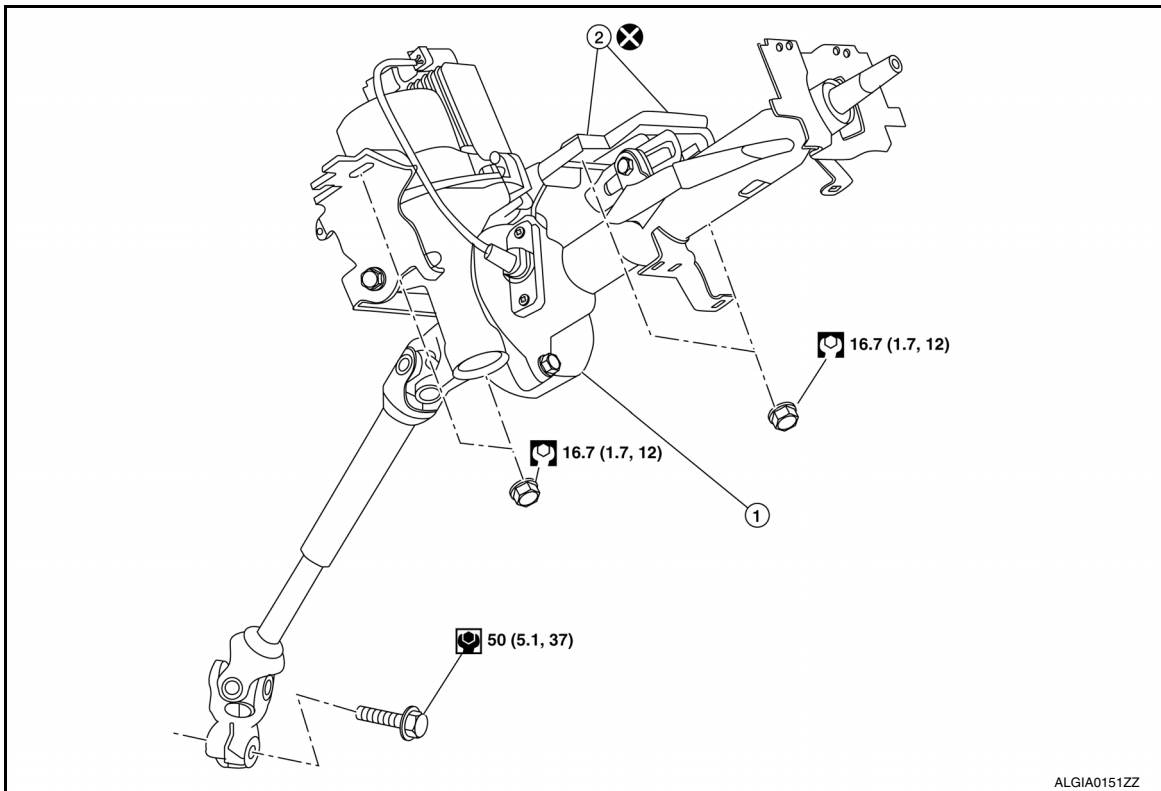

1. Steering column assembly

2. Slide plates

3. lower shaft assembly

Removal and Installation

INFOID:000000009759139

REMOVAL

CAUTION:

- While removing the steering column assembly, do not unlock the tilt lever.
- Do not impact on the axis when removing steering column assembly.
- Be careful when removing steering column assembly from the vehicle because it is heavy.
- Keep steering column assembly away from magnetic sources.
- Do not disassemble steering column assembly, it is all one piece.
- While removing the steering column assembly, do not move the steering gear assembly.
- When removing the steering column assembly, be careful not to allow the lower shaft assembly to turn.

1. Set steering wheel to the straight-ahead position.
2. Place the tilt to the lowest level.

CAUTION:

Securely lock the tilt lever.

3. Remove instrument lower panel LH. Refer to [IP-21. "Removal and Installation"](#).
4. Remove driver air bag module. Refer to [SR-12. "Removal and Installation"](#).
5. Remove steering wheel. Refer to [ST-10. "Removal and Installation"](#).
6. Remove steering column cover. Refer to [IP-16. "Removal and Installation"](#).
7. Remove spiral cable. Refer to [SR-16. "Removal and Installation"](#).
8. Remove combination switch.
9. Disconnect key interlock cable (if equipped). Refer to [TM-260. "Removal and Installation"](#).

STEERING COLUMN

< REMOVAL AND INSTALLATION >

10. Remove hole cover (1).
 - Lower shaft assembly (2).

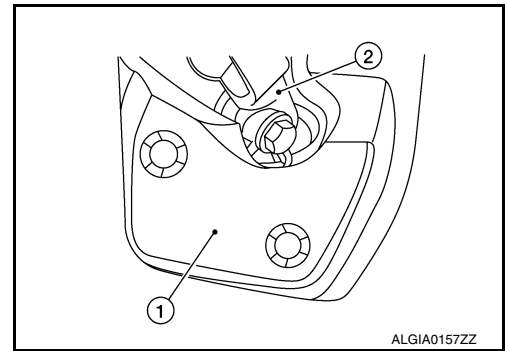

11. Remove lower side bolt of lower shaft assembly.
12. Disconnect each harness connector and harness clips installed to steering column assembly.
13. Disconnect EPS control unit harness connectors.
14. Remove the steering column assembly nuts.
CAUTION:
When removing the steering column assembly nuts, be careful not to drop the steering column assembly.
15. Remove the steering column.
16. Remove EPS control unit. Refer to [STC-39, "Removal and Installation"](#).

INSTALLATION

CAUTION:

- Do not impact on the axis when removing steering column assembly.
- When installing the steering column cover, check that the vehicle harness is not stuck in the cover.

Installation is in the reverse order of removal.

- After tightening nut (A) of the steering column assembly, press in slide plate (outer and inner) (1) to tighten nut (B).

CAUTION:

- Do not reuse slide plate.
- The slide plate must be securely pressed in before tightening the nut of slide plate.
- Lower shaft bolt is directional. Refer to [ST-12, "Exploded View"](#).

CAUTION:

Do not reuse lower shaft assembly bolt.

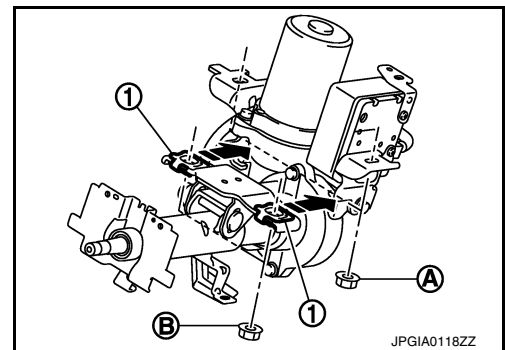

- After installing steering column assembly, perform self-diagnosis with CONSULT to ensure correct operation. Refer to [STC-10, "CONSULT Function"](#).
- Perform inspection after installation. Refer to [ST-7, "Inspection"](#).

STEERING GEAR AND LINKAGE

< REMOVAL AND INSTALLATION >

STEERING GEAR AND LINKAGE

Exploded View

INFOID:000000009759140

REMOVAL

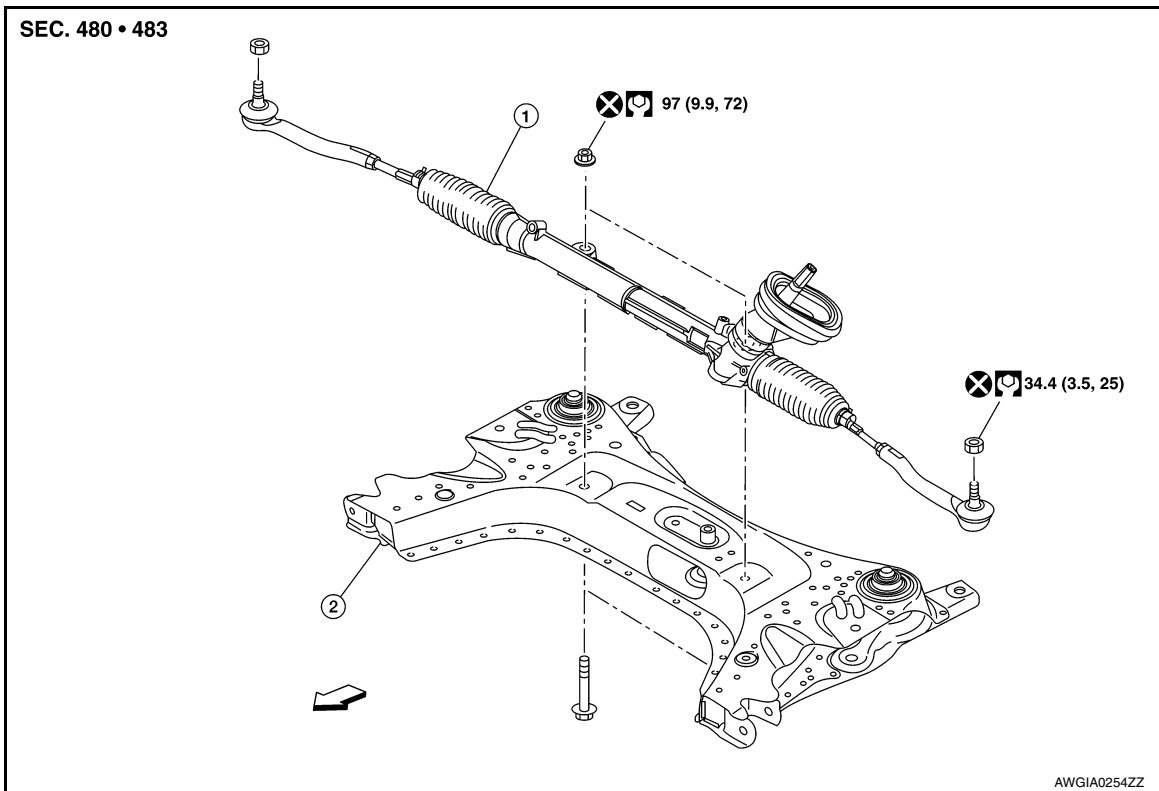

1. Steering gear assembly

2. Front suspension member

← Front

Removal and Installation

INFOID:000000009759141

REMOVAL

1. Set steering wheel to the straight-ahead position.
2. Remove floor cover (1).
 - Lower shaft assembly (2).

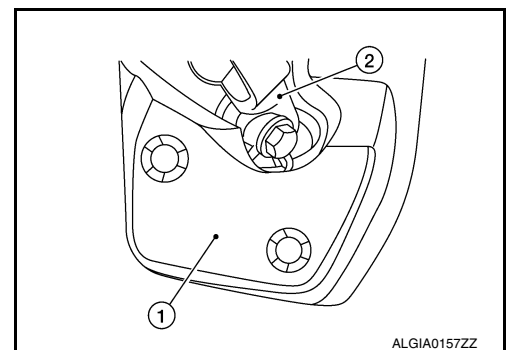

3. Remove the lower shaft assembly bolt and position the lower shaft assembly out of the way. Refer to [ST-12, "Removal and Installation"](#).

CAUTION:

- Spiral cable may be cut if steering wheel turns while separating steering column assembly and steering gear assembly. Always fix the steering wheel using string to avoid turning.
 - Place a matching mark on both intermediate shaft and steering gear assembly before removing intermediate shaft.
4. Remove wheels and tires using power tool. Refer to [WT-47, "Adjustment"](#).

STEERING GEAR AND LINKAGE

< REMOVAL AND INSTALLATION >

5. Remove steering outer socket from steering knuckle so as not to damage ball joint boot using Tool.

Tool number : HT72520000 (J-25730-A)

CAUTION:

Temporarily tighten the nut to prevent damage to threads and to prevent the Tool from a sudden drop.

6. Remove front suspension member. Refer to [FSU-16, "Removal and Installation"](#).
7. Remove steering gear assembly from front suspension member.

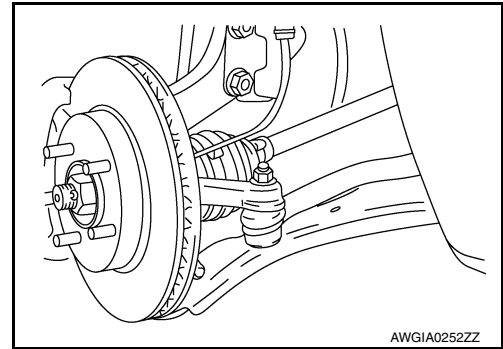

INSTALLATION

Installation is in the reverse order of removal.

CAUTION:

Spiral cable may be cut if steering wheel turns while separating steering column assembly and steering gear assembly. Always fix the steering wheel using string to avoid turning.

- Perform final tightening of nuts and bolts on each part under unladen conditions with tires on level ground when removing steering gear assembly.
- Check wheel alignment. Refer to [FSU-7, "Adjustment"](#).
- Rotate steering wheel to check for decentered condition, binding, noise or excessive steering effort.
- Do not reuse steering outer socket nut and steering gear assembly nut.
- Perform neutral position steering angle adjustment. Refer to [BRC-54, "Work Procedure"](#).

A
B
C
D
E
F
ST
H
I
J
K
L
M
N
O
P

STEERING GEAR AND LINKAGE

< UNIT DISASSEMBLY AND ASSEMBLY >

UNIT DISASSEMBLY AND ASSEMBLY

STEERING GEAR AND LINKAGE

Exploded View

INFOID:000000009759142

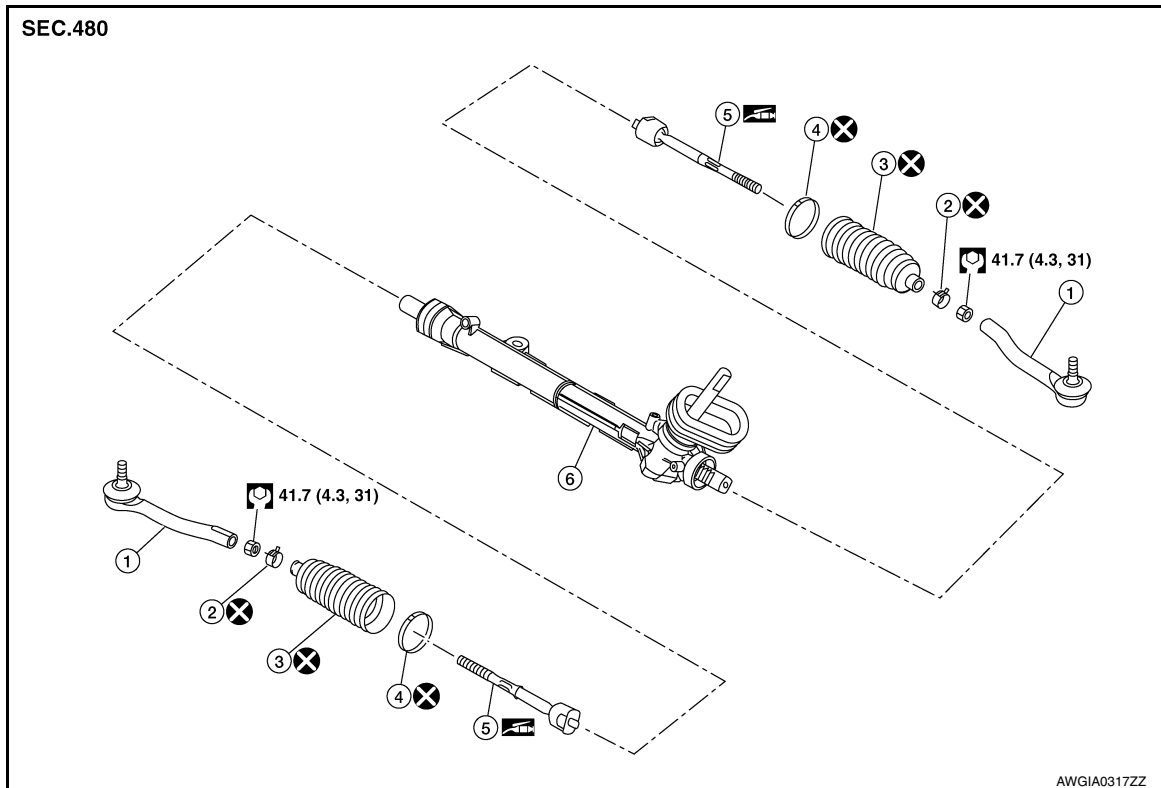

- | | | |
|--------------------------------|--------------------------------|--------------------------|
| 1. Outer socket | 2. Boot clamp (small diameter) | 3. Boot |
| 4. Boot clamp (large diameter) | 5. Inner socket | 6. Gear housing assembly |

Disassembly and Assembly

INFOID:000000009759143

DISASSEMBLY

1. Loosen outer socket lock nut, and remove outer socket.

CAUTION:

When loosening lock nut, be sure to fix outer socket with a wrench or an equivalent.

2. Remove boot clamps, and then remove boot from inner socket.

CAUTION:

- Do not damage inner socket part and gear housing part of steering gear assembly when removing boot. steering gear assembly must be replaced if steering gear assembly are damaged because it may cause foreign material interfusion.
- Do not reuse boot clamps.

3. Remove inner socket.

ASSEMBLY

STEERING GEAR AND LINKAGE

< UNIT DISASSEMBLY AND ASSEMBLY >

1. Apply recommended grease to inner socket (A) of gear housing assembly, and install boot to gear housing assembly.
Use **Genuine Lithium Soap, Autorex A** (manufactured by **Kyodo yushi**) or equivalent.

CAUTION:

Do not reuse boot.

Grease application position (Reference)

(B) : 10 mm (0.39 in)

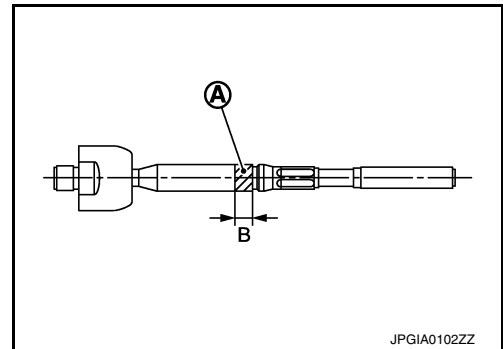

2. Install boot clamp (large diameter) (1) to boot using Tool.

CAUTION:

- Do not reuse boot clamp (large diameter).
- Install boot clamp (large diameter) securely to boot groove, and crimp it so as to have clearance (B) of 3 mm (0.12 in) or less as shown.

Tool number (A) : KV40107300 (—)

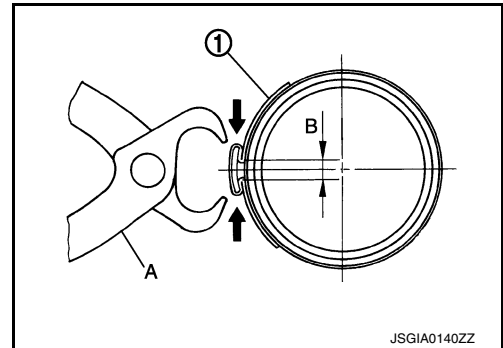

3. Install boot clamp (small diameter) to boot.

CAUTION:

Do not reuse boot clamp (small diameter).

4. Adjust inner socket to standard length (L), and then tighten outer socket lock nut (1) to the specified torque. Check length again after tightening lock nut.

(L) : Refer to [ST-19, "Power Steering Gear"](#).

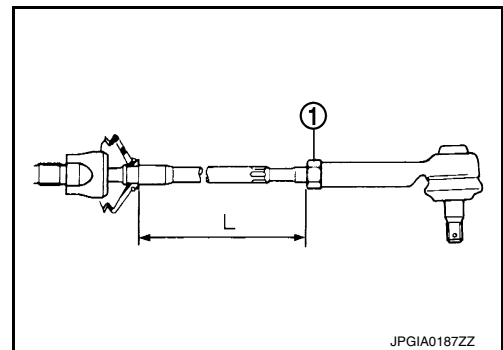

CAUTION:

- When tightening the outer socket lock nut (1), be sure to fix outer socket (2) with suitable tool to prevent the ball joint from getting contact with the knuckle.
- Adjust toe-in after this procedure. The length achieved after toe-in adjustment is not necessary the above value.

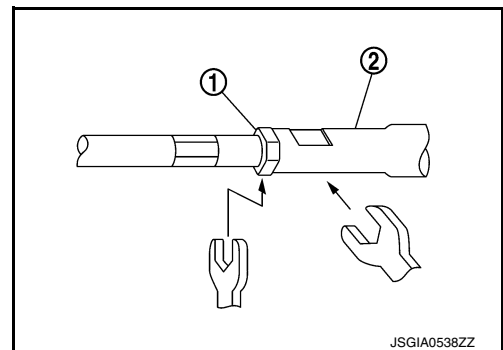

SERVICE DATA AND SPECIFICATIONS (SDS)

< SERVICE DATA AND SPECIFICATIONS (SDS)

SERVICE DATA AND SPECIFICATIONS (SDS)

SERVICE DATA AND SPECIFICATIONS (SDS)

Steering Wheel

INFOID:000000009759144

Steering wheel axial end play	0 mm (0 in)
Steering wheel play	0 - 35 mm (0 - 1.38 in)
Steering wheel turning force	36 N (3.7 kg-f, 8.09 lb-f) or less

Steering Angle

INFOID:000000009759145

Unit: Degree minute (Decimal Degree)

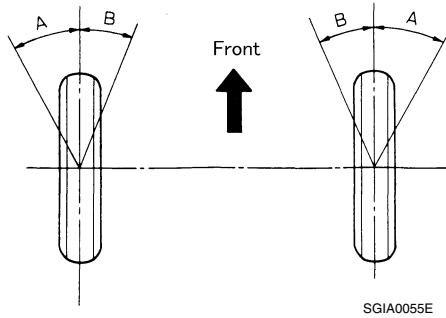

Inner wheel angle (A)	Minimum	36° 30' (36.5°)
	Nominal	39° 30' (39.5°)
	Maximum	40° 30' (40.5°)
Outer wheel angle (B)	Nominal	33° 30' (33.5°)

Steering Column

INFOID:000000009759146

STEERING COLUMN LENGTH

Unit: mm (in)

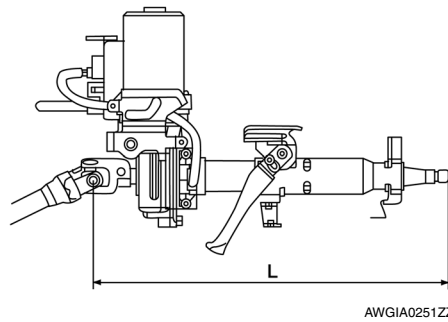

Steering column length	Length (L)	463 (18.2)
	Telescopic maximum	478 (18.8)
	Telescopic minimum	448 (17.6)

TILT MECHANISM OPERATING RANGE

SERVICE DATA AND SPECIFICATIONS (SDS)

< SERVICE DATA AND SPECIFICATIONS (SDS)

Unit: mm (in)

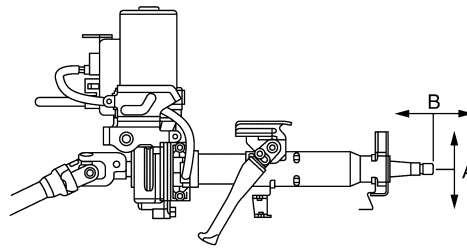

JSGIA1084ZZ

Tilt mechanism operating range (A)	40 (1.6)
Telescopic mechanism operating range (B)	30 (1.2)

Power Steering Gear

INFOID:000000009759147

STEERING OUTER SOCKET AND INNER SOCKET

Outer socket	Rocking torque	0.3 - 2.9 N·m (0.03 - 0.29 kg-m, 3.0 - 25 in-lb)
	<ul style="list-style-type: none"> • Measurement on spring balance • Measuring point: cotter pin hole of stud 	6.0 - 58 N (0.61 - 5.9 kg, 1.3 - 13 lb)
	Rotating torque	0.3 - 2.0 N·m (0.03 - 0.2 kg-m, 3.0 - 18 in-lb)
	Axial end play	0.4 mm (0.020 in) or less
Inner socket	Rocking torque	0.5 - 5.0 N·m (0.05 - 0.51 kg-m, 4.4 - 44 in-lb)
	<ul style="list-style-type: none"> • Measurement on spring balance • Measuring point at * mark shown 	4.3 - 43.1 N (0.44 - 4.40 kg, 0.97 - 9.69 lb)
	Axial end play	0.2 mm (0.008 in) or less
Inner socket length (L)		197 mm (7.8 in) or less

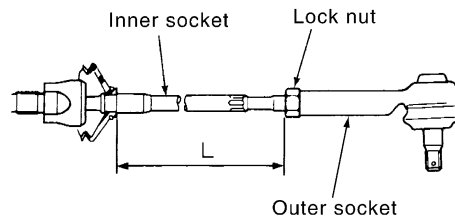

SGIA0167E

RACK STROKE

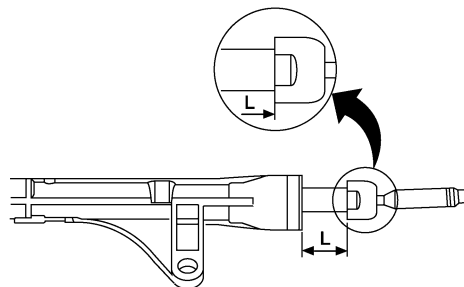

AWGIA0003GB

Rack stroke in neutral position (L)	73.0 mm (2.9 in)
-------------------------------------	------------------