

A
CO
C
D
E
F
G
H
I
J
K
L
M
N
O
P

SECTION CO

ENGINE COOLING SYSTEM

CONTENTS

| | |
|--|--|
| MRA8DE | |
| PRECAUTION | RADIATOR15 |
| PRECAUTIONS | Exploded View15 |
| Precaution for Supplemental Restraint System (SRS) "AIR BAG" and "SEAT BELT PRE-TEN- SIONER" | Removal and Installation15 |
| Precaution for Liquid Gasket | Inspection16 |
| PREPARATION | COOLING FAN17 |
| PREPARATION | Component17 |
| Special Service Tool | Removal and Installation17 |
| Commercial Service Tool | WATER PUMP19 |
| SYSTEM DESCRIPTION | Exploded View19 |
| DESCRIPTION | Removal and Installation19 |
| Engine Cooling System Schematic | THERMOSTAT AND THERMOSTAT HOUS- ING21 |
| SYMPTOM DIAGNOSIS | Exploded View21 |
| OVERHEATING CAUSE ANALYSIS | Removal and Installation of Thermostat21 |
| Troubleshooting Chart | Removal and Installation of Thermostat Housing ...22 |
| PERIODIC MAINTENANCE | Inspection23 |
| ENGINE COOLANT | WATER OUTLET24 |
| System Inspection | Exploded View24 |
| Changing Engine Coolant | Removal and Installation25 |
| REMOVAL AND INSTALLATION | SERVICE DATA AND SPECIFICATIONS (SDS)27 |
| | SERVICE DATA AND SPECIFICATIONS (SDS)27 |
| | Periodical Maintenance Specification27 |
| | Radiator27 |
| | Thermostat27 |
| | Water Control Valve27 |

< PRECAUTION >

PRECAUTION

PRECAUTIONS

Precaution for Supplemental Restraint System (SRS) "AIR BAG" and "SEAT BELT PRE-TENSIONER"

INFOID:000000011537123

The Supplemental Restraint System such as "AIR BAG" and "SEAT BELT PRE-TENSIONER", used along with a front seat belt, helps to reduce the risk or severity of injury to the driver and front passenger for certain types of collision. Information necessary to service the system safely is included in the SR and SB section of this Service Manual.

WARNING:

- To avoid rendering the SRS inoperative, which could increase the risk of personal injury or death in the event of a collision which would result in air bag inflation, all maintenance must be performed by an authorized NISSAN/INFINITI dealer.
- Improper maintenance, including incorrect removal and installation of the SRS, can lead to personal injury caused by unintentional activation of the system. For removal of Spiral Cable and Air Bag Module, see the SR section.
- Do not use electrical test equipment on any circuit related to the SRS unless instructed to in this Service Manual. SRS wiring harnesses can be identified by yellow and/or orange harnesses or harness connectors.

PRECAUTIONS WHEN USING POWER TOOLS (AIR OR ELECTRIC) AND HAMMERS

WARNING:

- When working near the Airbag Diagnosis Sensor Unit or other Airbag System sensors with the Ignition ON or engine running, DO NOT use air or electric power tools or strike near the sensor(s) with a hammer. Heavy vibration could activate the sensor(s) and deploy the air bag(s), possibly causing serious injury.
- When using air or electric power tools or hammers, always switch the Ignition OFF, disconnect the battery and wait at least three minutes before performing any service.

Precaution for Liquid Gasket

INFOID:000000011537124

REMOVAL OF LIQUID GASKET

- After removing the bolts and nuts, separate the mating surface and remove the old liquid gasket using Tool.

Tool number : KV10111100 (J-37228)

CAUTION:

Do not damage the mating surfaces.

- Tap the seal cutter to insert it (1).
- In areas where the Tool is difficult to use, lightly tap to slide it (2).

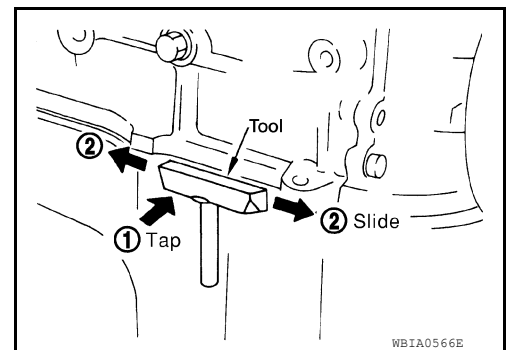

LIQUID GASKET APPLICATION PROCEDURE

1. Remove the old liquid gasket adhering to the gasket application surface and the mating surface using suitable tool.
 - Remove the liquid gasket completely from the groove of the liquid gasket application surface, bolts, and bolt holes.
2. Thoroughly clean the mating surfaces and remove adhering moisture, grease and foreign material.

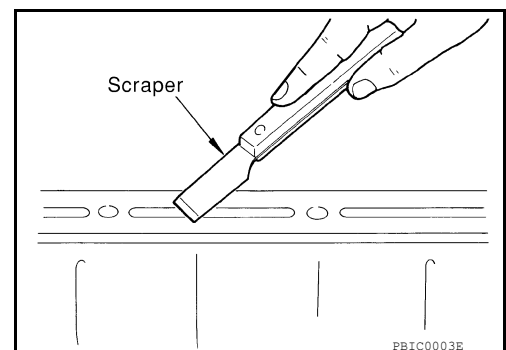

PRECAUTIONS

[MRA8DE]

< PRECAUTION >

3. Attach the liquid gasket tube to the suitable tool.
Use Genuine RTV Silicone Sealant or equivalent. Refer to [GI-21, "Recommended Chemical Products and Sealants"](#).
4. Apply the liquid gasket without breaks to the specified location with the specified dimensions.

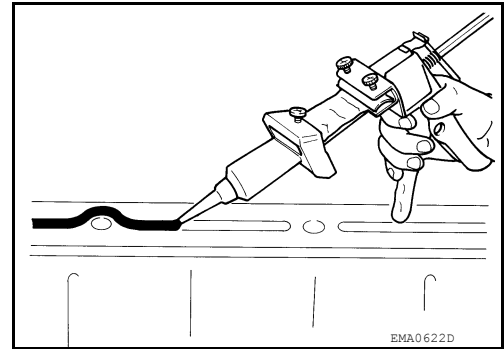

- If there is a groove for the liquid gasket application, apply the liquid gasket to the groove.
- Normally apply the liquid gasket on the inside edge of the bolt holes. Also apply to the outside edge of the bolt holes when specified in the procedure.
- Within five minutes of liquid gasket application, install the mating component.
- If the liquid gasket protrudes, wipe it off immediately.
- Do not retighten after the installation.
- Wait 30 minutes or more after installation before refilling the engine with oil or coolant.

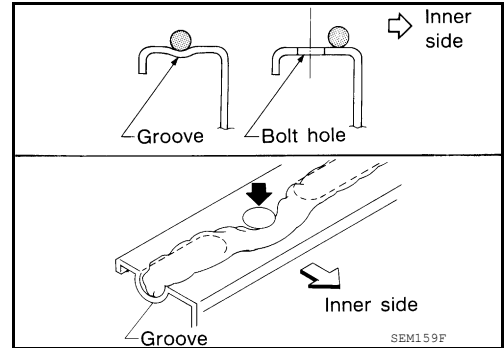

CAUTION:

If there are more specific instructions in the procedures contained in this manual concerning liquid gasket application, observe them.

PREPARATION

[MRA8DE]

< PREPARATION >

PREPARATION

PREPARATION

Special Service Tool

INFOID:000000011537125

The actual shape of the tools may differ from those illustrated here.

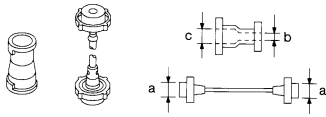
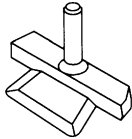
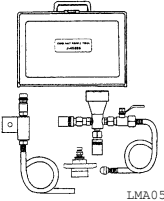
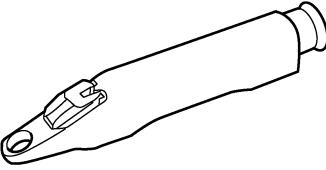
| Tool number (TechMate No.) Tool name | Description |
|--|--|
| EG17650301 (J-33984-A) Radiator cap tester adapter  S-NT564 | Adapting radiator cap tester to radiator cap and radiator filler neck a: 28 (1.10) dia. b: 31.4 (1.236) dia. c: 41.3 (1.626) dia. Unit: mm (in) |
| KV10111100 (J-37228) Seal cutter  NT046 | Removing chain tensioner cover and water pump cover |
| KV991J0070 (J-45695) Engine coolant Refill Tool  LMA053 | Refilling engine cooling system |
| — (J-23688) Engine coolant refractometer  WBIA0539E | Checking concentration of ethylene glycol in engine coolant |

Commercial Service Tool

INFOID:000000011537126

PREPARATION

< PREPARATION >

[MRA8DE]

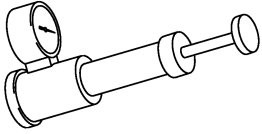
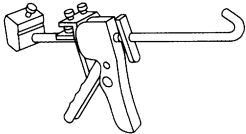
| Tool name | Description |
|--|---|
| <p>Power tool</p> <div style="text-align: center;">  <p>PIIB1407E</p> </div> | <p>Loosening nuts, screws and bolts</p> |
| <p>Radiator cap tester</p> <div style="text-align: center;">  <p>PBIC1982E</p> </div> | <p>Testing radiator cap</p> |
| <p>Tube presser</p> <div style="text-align: center;">  <p>S-NT052</p> </div> | <p>Pressing the tube of liquid gasket</p> |

A

CO

C

D

E

F

G

H

I

J

K

L

M

N

O

P

SYSTEM DESCRIPTION

DESCRIPTION

Engine Cooling System Schematic

INFOID:000000011537127

CVT MODELS

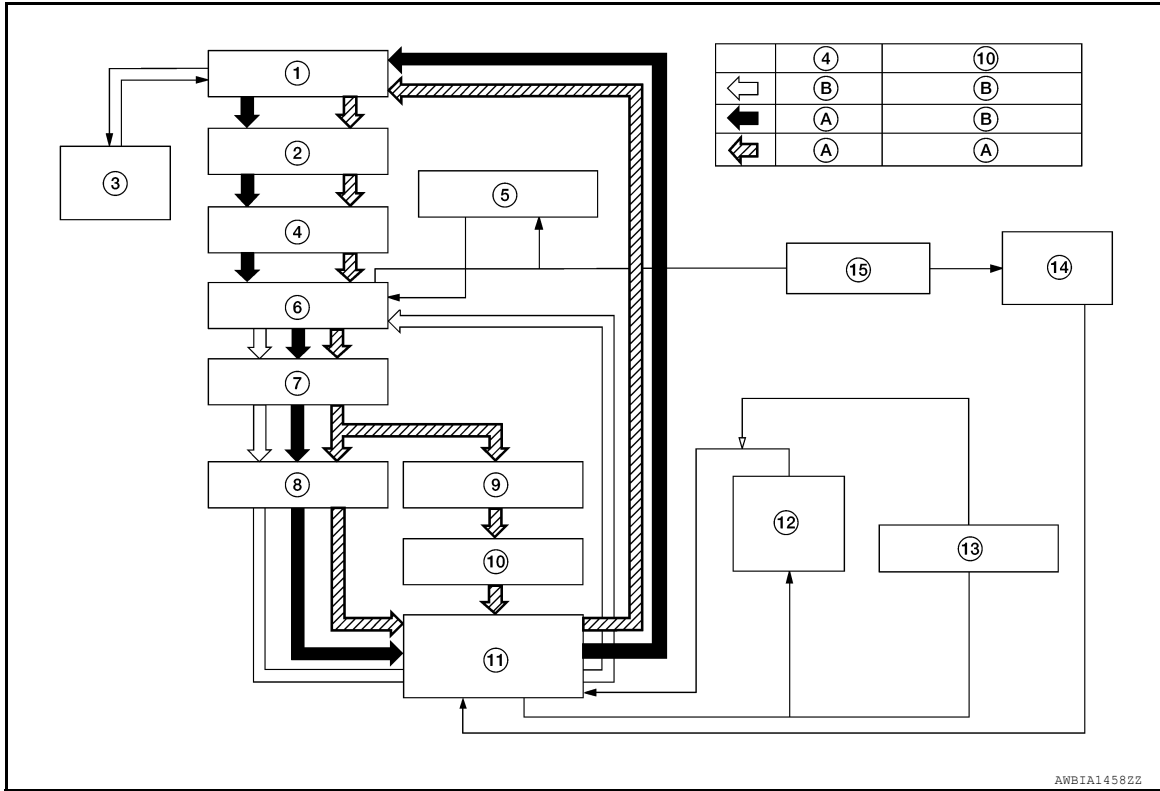

- 1. Radiator
 - 2. Water inlet
 - 3. Reservoir tank
 - 4. Thermostat
 - 5. Engine oil cooler
 - 6. Thermostat housing
 - 7. Water pump
 - 8. Cylinder head
 - 9. Cylinder block
 - 10. Water control valve
 - 11. Water outlet
 - 12. Heater
 - 13. Electric throttle control actuator
 - 14. CVT oil warmer
 - 15. Heater thermostat
- A. Open
B. Closed

DESCRIPTION

< SYSTEM DESCRIPTION >

[MRA8DE]

CVT MODELS

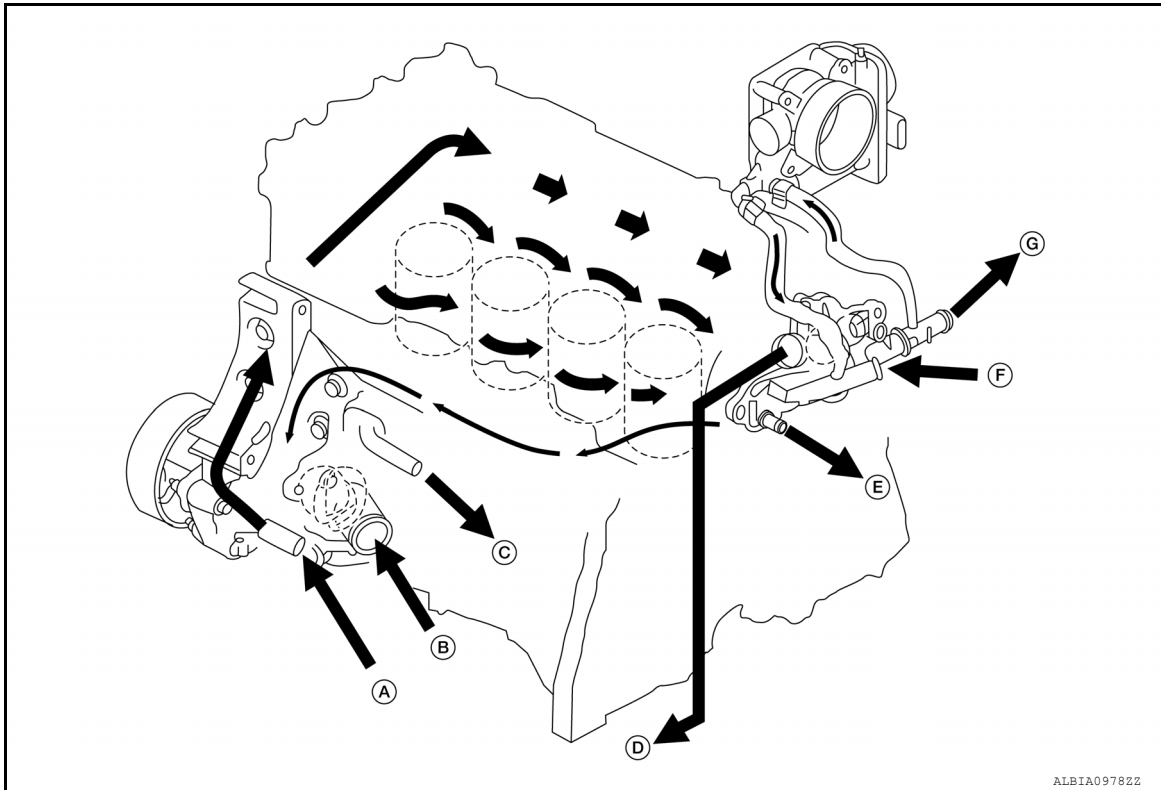

- A. From heater thermostat
- B. From radiator
- C. To engine oil cooler
- D. To filler neck
- E. To CVT oil warmer
- F. From heater core
- G. To heater core

M/T MODELS

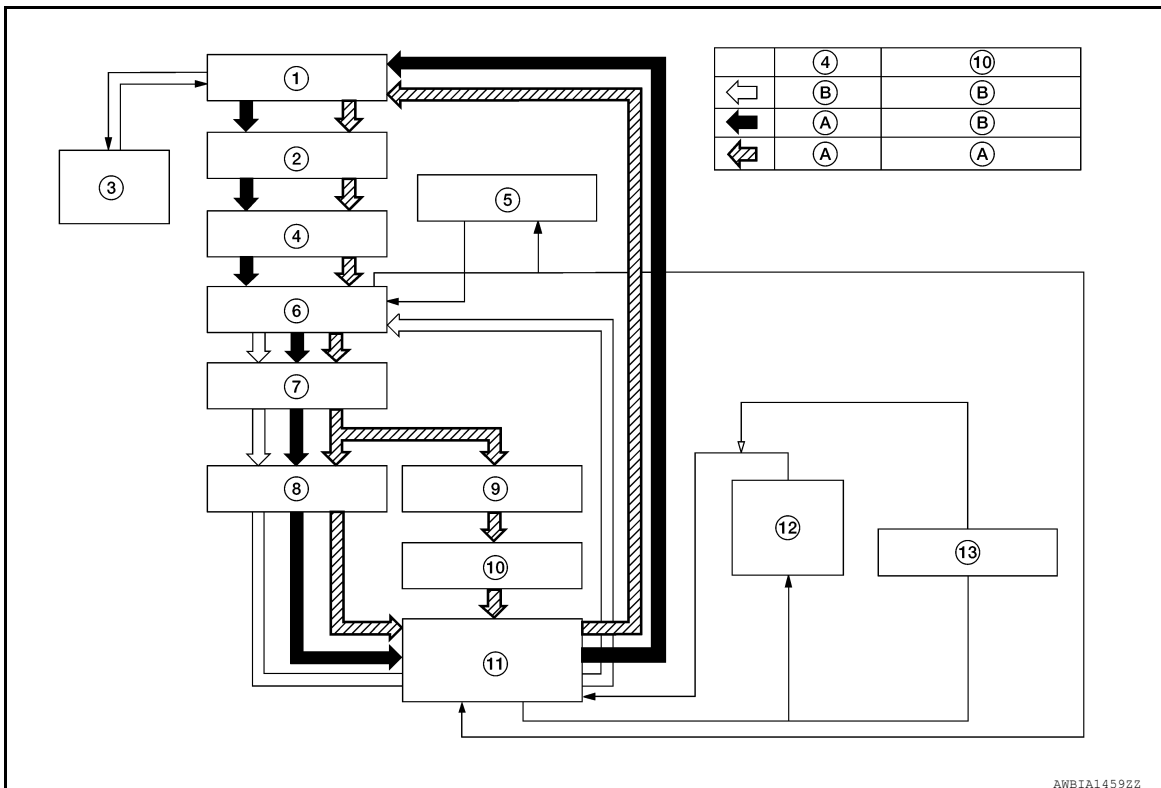

- 1. Radiator
- 2. Water inlet
- 3. Reservoir tank
- 4. Thermostat
- 5. Engine oil cooler
- 6. Thermostat housing

A
CO
C
D
E
F
G
H
I
J
K
L
M
N
O
P

DESCRIPTION

[MRA8DE]

< SYSTEM DESCRIPTION >

- | | | |
|--|------------------|-------------------|
| 7. Water pump | 8. Cylinder head | 9. Cylinder block |
| 10. Water control valve | 11. Water outlet | 12. Heater |
| 13. Electric throttle control actuator | A. Open | B. Closed |

M/T MODELS

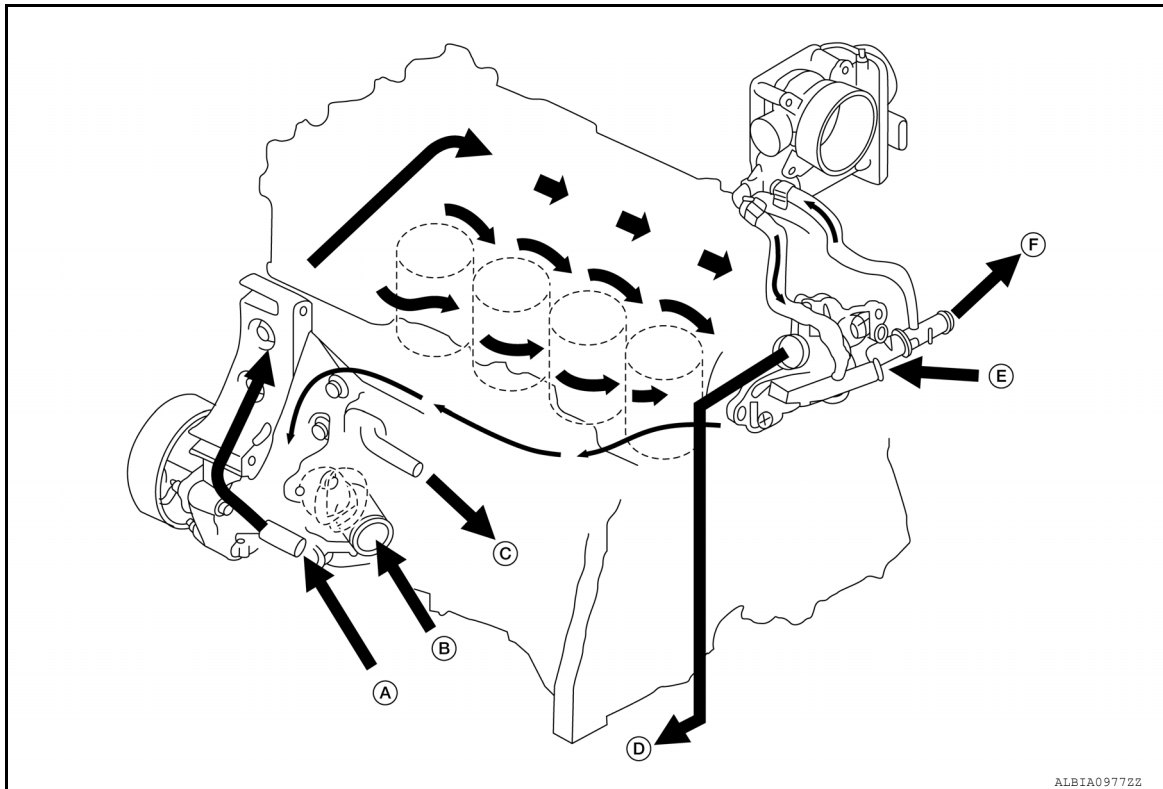

- | | | |
|---------------------------|---------------------|-------------------------|
| A. From heater thermostat | B. From radiator | C. To engine oil cooler |
| D. To filler neck | E. From heater core | F. To heater core |

OVERHEATING CAUSE ANALYSIS

< SYMPTOM DIAGNOSIS >

[MRA8DE]

SYMPTOM DIAGNOSIS

OVERHEATING CAUSE ANALYSIS

Troubleshooting Chart

INFOID:000000011537128

A

CO

| | | Symptom | Check items | | |
|----------------------------------|---------------------------------------|--|--|--------------------------|---|
| Cooling system parts malfunction | Poor heat transfer | Water pump malfunction | Worn or loose drive belt | — | |
| | | Thermostat stuck closed | Engine coolant circulation | | |
| | | Damaged fins | Dust contamination or rock clogging | | |
| | | | Mechanical damage | | |
| | | Clogged radiator cooling tube | Excess foreign material (rust, dirt, sand, etc.) | | |
| | Reduced air flow | Cooling fan does not operate | Fan shroud and motor assembly | — | |
| | | High resistance to fan rotation | | | |
| | | Damaged fan blades | | | |
| | | Damaged radiator shroud | — | Radiator shroud | — |
| | | Improper engine coolant mixture ratio | — | Engine coolant viscosity | — |
| | | Poor engine coolant quality | — | Periodic maintenance | — |
| | Insufficient engine coolant | Engine coolant leaks | Cooling hose | Loose clamp | |
| | | | | Cracked hose | |
| | | | Water pump | Poor sealing | |
| | | | Radiator cap | Loose | |
| Poor sealing | | | | | |
| Radiator | | O-ring for damage, deterioration or improper fitting | | | |
| | | Cracked radiator tank | | | |
| | | Cracked radiator core | | | |
| | Reservoir tank | Cracked reservoir tank | | | |
| Overflowing reservoir tank | Exhaust gas leaks into cooling system | Cylinder head deterioration | | | |
| | | Cylinder head gasket deterioration | | | |

C

D

E

F

G

H

I

J

K

L

M

N

O

P

OVERHEATING CAUSE ANALYSIS

< SYMPTOM DIAGNOSIS >

[MRA8DE]

| | Symptom | | Check items | | |
|---|--------------------------------|--------------------------------|--|---------------------------------------|---|
| Except cooling system parts malfunction | — | Overload on engine | Abusive driving | High engine rpm under no load | |
| | | | | Driving in low gear for extended time | |
| | | | | Driving at extremely high speed | |
| | | | Powertrain system malfunction | — | |
| | | | Installed improper size wheels and tires | | |
| | | | Dragging brakes | | |
| | Blocked or restricted air flow | Blocked or restricted air flow | Blocked radiator grille | Installed car brassiere | — |
| | | | Blocked bumper | Mud contamination or paper clogging | |
| | | | Blocked radiator | | |
| | | | Blocked condenser | | |
| Installed large fog lamp | | | | | |

PERIODIC MAINTENANCE

ENGINE COOLANT

System Inspection

INFOID:000000011537129

WARNING:

- Do not remove the radiator cap when the engine is hot. Serious burns could occur from high pressure engine coolant escaping from the radiator.
- Wrap a thick cloth around the cap. Slowly push down and turn it a quarter turn to allow built-up pressure to escape. Carefully remove the cap by pushing down and turning it all the way.

CHECKING COOLING SYSTEM HOSES

Check hoses for the following:

- Improper attachment
- Leaks
- Cracks
- Damage
- Loose connections
- Chafing
- Deterioration

CHECKING RESERVOIR LEVEL

- Check if the reservoir tank engine coolant level is within MIN to MAX when the engine is cool.
- Adjust engine coolant level if it is too much or too little.

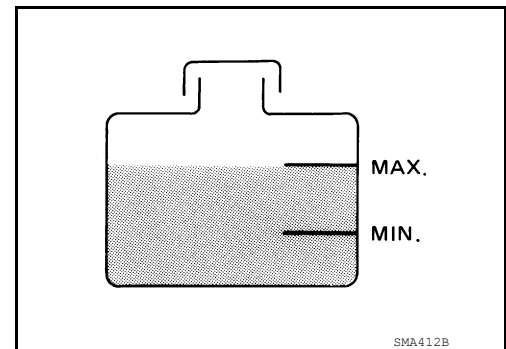

CHECKING COOLING SYSTEM FOR LEAKS

To check for leaks, apply pressure to the cooling system using suitable tool (A) and Tool (B).

Tool number (B) : EG17650301 (J-33984-A)

Testing pressure : Refer to [CO-27, "Radiator"](#).

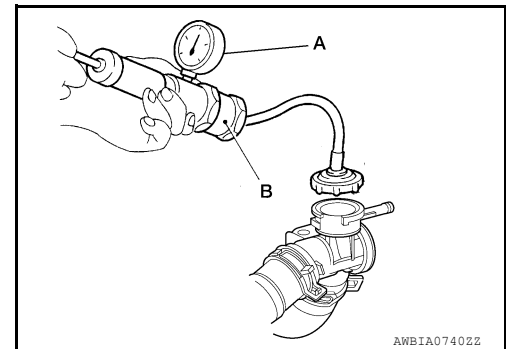

WARNING:

Do not remove the radiator cap when the engine is hot. Serious burns could occur from high pressure engine coolant escaping from the radiator.

CAUTION:

Higher pressure than specified may cause radiator damage.

CHECKING RADIATOR CAP

1. Inspect the radiator cap.
 - Replace the cap if the metal plunger cannot be seen around the edge of the black rubber gasket.
 - Replace the cap if deposits of waxy residue or other foreign material are on the black rubber gasket or the metal retainer.

NOTE:

Thoroughly wipe out the radiator filler neck to remove any waxy residue or foreign material.

ENGINE COOLANT

[MRA8DE]

< PERIODIC MAINTENANCE >

2. Pull the negative-pressure valve to open it and check that it closes completely when released.
 - Check that there is no dirt or damage on the valve seat of the radiator cap negative-pressure valve.
 - Check that there are no abnormalities in the opening and closing conditions of the negative-pressure valve.

Negative pressure : Refer to [CO-27, "Radiator"](#).

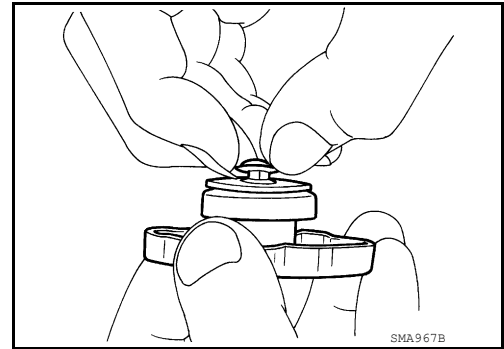

3. Check radiator cap relief pressure using suitable tool and Tool.

Tool number : EG17650301 (J-33984-A)

Positive pressure (relief) : Refer to [CO-27, "Radiator"](#).

- When connecting the radiator cap to the tester, apply water or engine coolant to the cap seal surface.
- Replace the radiator cap if there is an abnormality in the negative-pressure valve, or if the open-valve pressure is outside of the standard values.

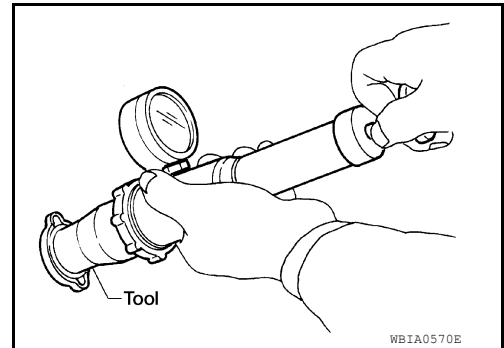

CHECKING RADIATOR

Check radiator for mud or clogging. If necessary, clean radiator as follows.

CAUTION:

- **Be careful not to bend or damage the radiator fins.**
- **When radiator is cleaned on-vehicle, remove surrounding parts in order to access the radiator core. Tape the harness and harness connectors to prevent water from entering.**

1. Spray water to the back side of the radiator core using a side to side motion from the top down.
2. Stop spraying when debris no longer flows from radiator core.
3. Blow air into the back side of radiator core using a side to side motion from the top down.
 - Use compressed air lower than 490 kPa (5 kg/cm², 71 psi) and keep distance more than 30 cm (11.8 in).
4. Continue to blow air until no water sprays out.
5. Check for engine coolant leaks. Repair as necessary.

Changing Engine Coolant

INFOID:000000011537130

WARNING:

- **To avoid being scalded, do not change the engine coolant when the engine is hot.**
- **Wrap a thick cloth around cap and carefully remove the cap. First, turn the cap a quarter of a turn to release built-up pressure. Then push down and turn the cap all the way to remove.**

DRAINING ENGINE COOLANT

1. Remove the engine under cover. Refer to [EXT-16, "Exploded View"](#).
2. Open the radiator drain plug (1) at the bottom of the radiator and remove the radiator filler cap. This is the only step required when partially draining the cooling system (radiator only).

CAUTION:

- **Do not spill engine coolant on the drive belt.**
- **Perform this step when the engine is cold.**

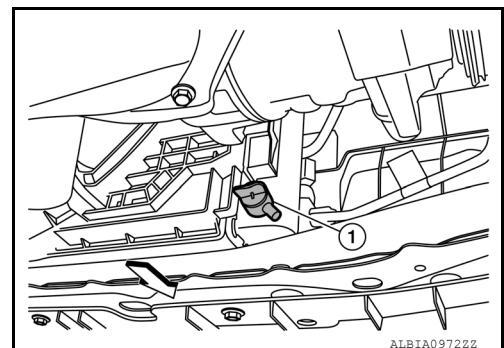

ENGINE COOLANT

[MRA8DE]

< PERIODIC MAINTENANCE >

3. Follow this step for heater core removal/replacement only. Disconnect the upper heater hose at the engine side and apply moderate air pressure [103.46 kPa (1.055 kg/cm², 15 psi) maximum air pressure] into the hose for 30 seconds to blow the excess engine coolant out of the heater core.
4. When draining all of the engine coolant in the system, remove the reservoir tank and drain the engine coolant, then clean the reservoir tank before installation.
CAUTION:
 - Do not allow the engine coolant to contact the drive belt.
 - Perform this step when engine is cold.
5. When draining all of the engine coolant in the system for engine removal or repair, remove the engine coolant drain plugs on the cylinder block.
6. Check the drained engine coolant for contaminants such as rust, corrosion or discoloration. If the engine coolant is contaminated, flush the engine cooling system.

REFILLING ENGINE COOLANT

1. Install the radiator drain plug. Install the reservoir tank and cylinder block drain plug, if removed for a total system drain or for engine removal or repair.
 - The radiator must be completely empty of engine coolant and water.
 - Apply sealant to the threads of the cylinder block drain plug. Use Genuine High Performance Thread Sealant or equivalent. Refer to [MA-11, "Fluids and Lubricants"](#).

Radiator drain plug : 1.17 N·m (0.12 kg-m, 10.0 in-lb)

2. If disconnected, reattach the upper radiator hose at the engine side.
3. Set the vehicle heater controls to the full HOT and heater ON position. Turn the vehicle ignition ON with the engine OFF as necessary to activate the heater mode.
4. Install the Tool by installing the radiator cap adapter onto the radiator neck opening. Then attach the gauge body assembly with the refill tube and the venturi assembly to the radiator cap adapter.

Tool number : KV991J0070 (J-45695)

5. Insert the refill hose into the engine coolant mixture container that is placed at floor level. Make sure the ball valve is in the closed position.
 - Use recommended engine coolant or equivalent. Refer to [MA-11, "Fluids and Lubricants"](#).

Engine coolant capacity (with reservoir tank) : Refer to [CO-27, "Periodical Maintenance Specification"](#).

CAUTION:

Do not use any cooling system additives such as radiator sealer. Additives may clog the cooling system and cause damage to the engine, transmission and/or cooling system.

6. Install an air hose to the venturi assembly, the air pressure must be within specification.

Compressed air supply pressure : 549 - 824 kPa (5.6 - 8.4 kg/cm², 80 - 119 psi)

CAUTION:

The compressed air supply must be equipped with an air dryer.

7. The vacuum gauge will begin to rise and there will be an audible hissing noise. During this process open the ball valve on the refill hose slightly. Engine coolant will be visible rising in the refill hose. Once the refill hose is full of engine coolant, close the ball valve. This will purge any air trapped in the refill hose.

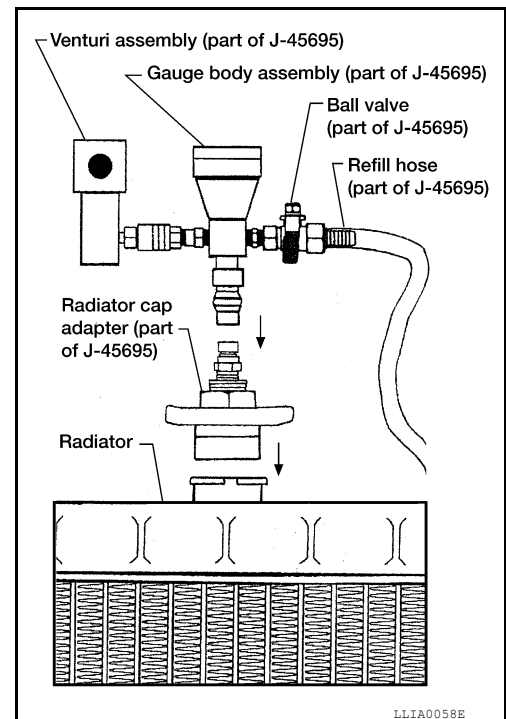

ENGINE COOLANT

[MRA8DE]

< PERIODIC MAINTENANCE >

- Continue to draw the vacuum until the gauge reaches 28 inches of vacuum. The gauge may not reach 28 inches in high altitude locations, use the vacuum specifications based on the altitude above sea level.

| Altitude above sea level | Vacuum gauge reading |
|--------------------------|----------------------------|
| 0 - 100 m (328 ft) | : 28 inches of vacuum |
| 300 m (984 ft) | : 27 inches of vacuum |
| 500 m (1,641 ft) | : 26 inches of vacuum |
| 1,000 m (3,281 ft) | : 24 - 25 inches of vacuum |

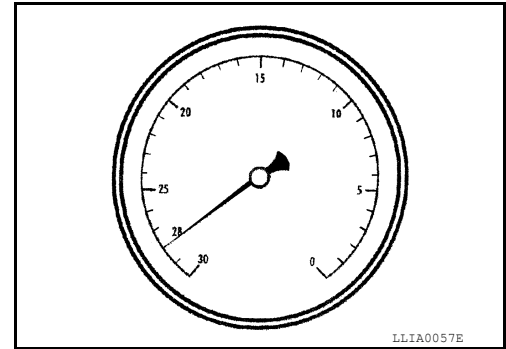

- When the vacuum gauge has reached the specified amount, disconnect the air hose and wait 20 seconds to see if the system loses any vacuum. If the vacuum level drops, perform any necessary repairs to the system and repeat steps 6 - 8 to bring the vacuum to the specified amount. Recheck for any leaks.
- Place the engine coolant container (with the refill hose inserted) at the same level as the top of the radiator. Then open the ball valve on the refill hose so the engine coolant will be drawn up to fill the cooling system. The cooling system is full when the vacuum gauge reads zero.

CAUTION:

Do not allow the engine coolant container to get too low when filling, to avoid air from being drawn into the cooling system.

- Remove the Tool from the radiator neck opening.
- Fill the cooling system reservoir tank to the specified level and install the radiator cap. Run the engine to warm up the cooling system and top up the system as necessary.
- Install the engine under cover. Refer to [EXT-16, "Exploded View"](#).

FLUSHING COOLING SYSTEM

- Fill the radiator from the filler neck above the radiator upper hose and reservoir tank with clean water and reinstall the radiator filler cap.
- Run the engine until it reaches normal operating temperature.
- Rev the engine two or three times under no-load.
- Stop the engine and wait until it cools down.
- Drain the water from the system. Refer to [CO-12, "Changing Engine Coolant"](#).
- Repeat steps 1 through 5 until clear water begins to drain from the radiator.

RADIATOR

< REMOVAL AND INSTALLATION >

[MRA8DE]

REMOVAL AND INSTALLATION

RADIATOR

Exploded View

INFOID:000000011537131

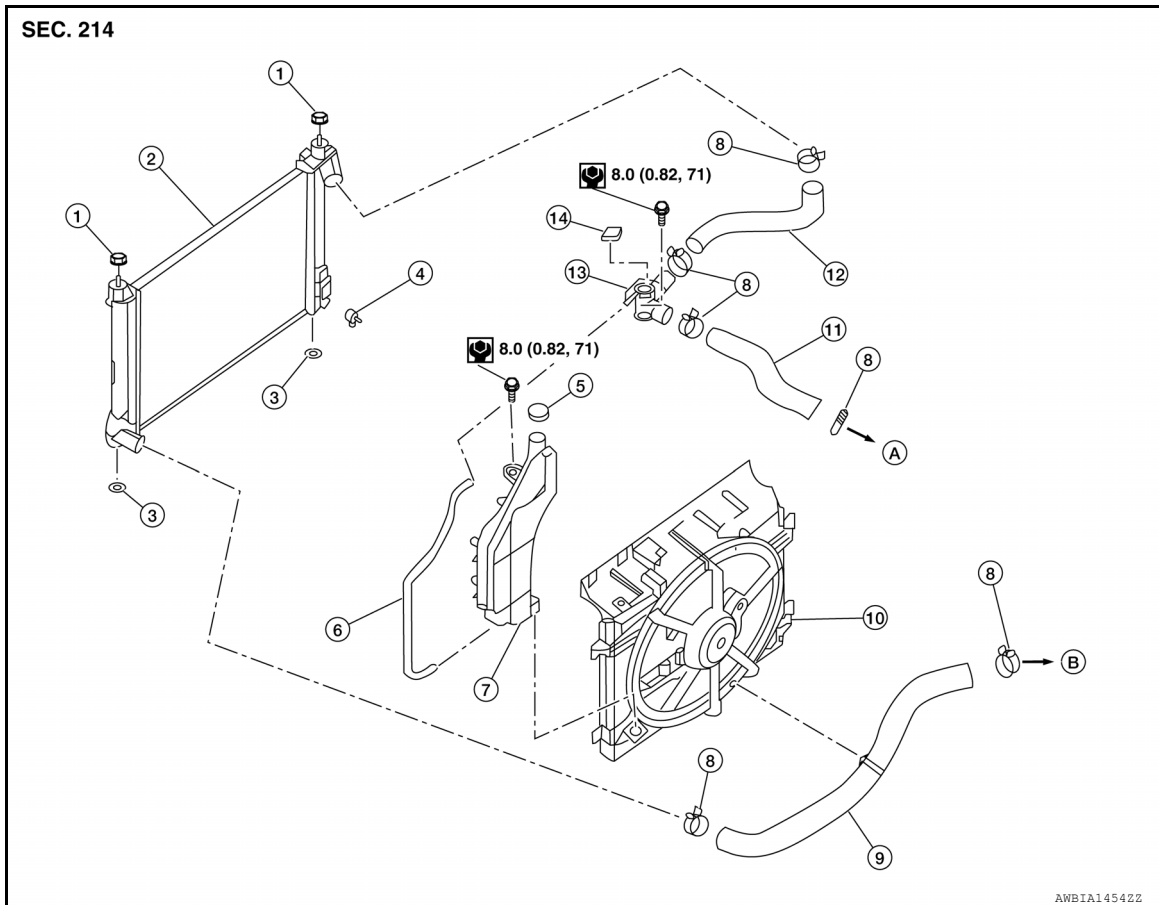

- | | | |
|-----------------------------------|---------------------------|----------------------------|
| 1. Mounting rubber (upper) | 2. Radiator | 3. Mounting rubber (lower) |
| 4. Radiator drain plug | 5. Reservoir tank cap | 6. Reservoir tank hose |
| 7. Reservoir tank | 8. Clamp | 9. Radiator hose (lower) |
| 10. Fan shroud and motor assembly | 11. Radiator hose (upper) | 12. Filler neck hose |
| 13. Filler neck | 14. Radiator filler cap | A. To water outlet |
| B. To water inlet | | |

Removal and Installation

INFOID:000000011537132

WARNING:

Do not remove the radiator cap when the engine is hot. Serious burns could occur from high-pressure engine coolant escaping from the radiator. Wrap a thick cloth around the cap. Slowly push down and turn it a quarter turn to allow built-up pressure to escape. Carefully remove the cap by pushing it down and turning it all the way.

NOTE:

When removing components such as hoses, tubes/lines, etc., cap or plug openings to prevent fluid from spilling.

REMOVAL

1. Disconnect the negative battery terminal. Refer to [PG-74, "Removal and Installation \(Battery\)"](#).
2. Remove fan shroud and motor assembly. Refer to [CO-17, "Removal and Installation"](#).

RADIATOR

[MRA8DE]

< REMOVAL AND INSTALLATION >

3. Remove radiator cap, open radiator drain plug (1) and drain engine coolant from radiator. Refer to [CO-12, "Changing Engine Coolant"](#).

CAUTION:

- Perform this step when the engine is cold.
- Do not spill engine coolant on the drive belt.

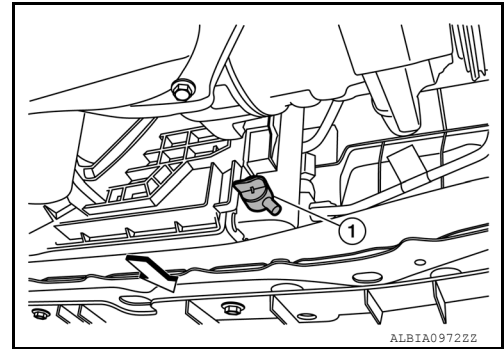

4. Remove radiator hose (lower). Refer to [CO-15, "Exploded View"](#).
5. Remove condenser bolts from radiator.
6. Remove the radiator from the vehicle.

CAUTION:

Be careful not to damage radiator core and condenser assembly core.

INSTALLATION

Installation is in the reverse order of removal.

- After installation, refill engine coolant and check for leaks. Refer to [CO-12, "Changing Engine Coolant"](#) and [CO-11, "System Inspection"](#).

CAUTION:

Do not spill engine coolant in engine compartment. Use a shop cloth to absorb engine coolant.

NOTE:

When installing radiator core support (upper), check that both upper and lower mounts of radiator and air conditioner condenser are inserted in the mounting holes of radiator core support (upper, lower).

Inspection

INFOID:000000011537133

INSPECTION AFTER INSTALLATION

- Check that the reservoir tank cap is tightened.
- Check for leaks of engine coolant using Tool (B) and suitable tool (A). Refer to [CO-11, "System Inspection"](#).

Tool number (B) : EG17650301 (J-33984-A)

Testing pressure : Refer to [CO-27, "Radiator"](#).

WARNING:

Do not remove the radiator cap when the engine is hot. Serious burns could occur from high pressure engine coolant escaping from the radiator.

CAUTION:

Higher pressure than specified may cause radiator damage.

- Start and warm up the engine. Visually check that there are no engine coolant or CVT fluid leaks.

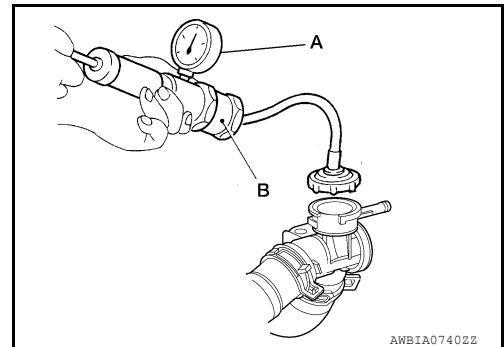

COOLING FAN

< REMOVAL AND INSTALLATION >

[MRA8DE]

COOLING FAN

Component

INFOID:0000000011537134

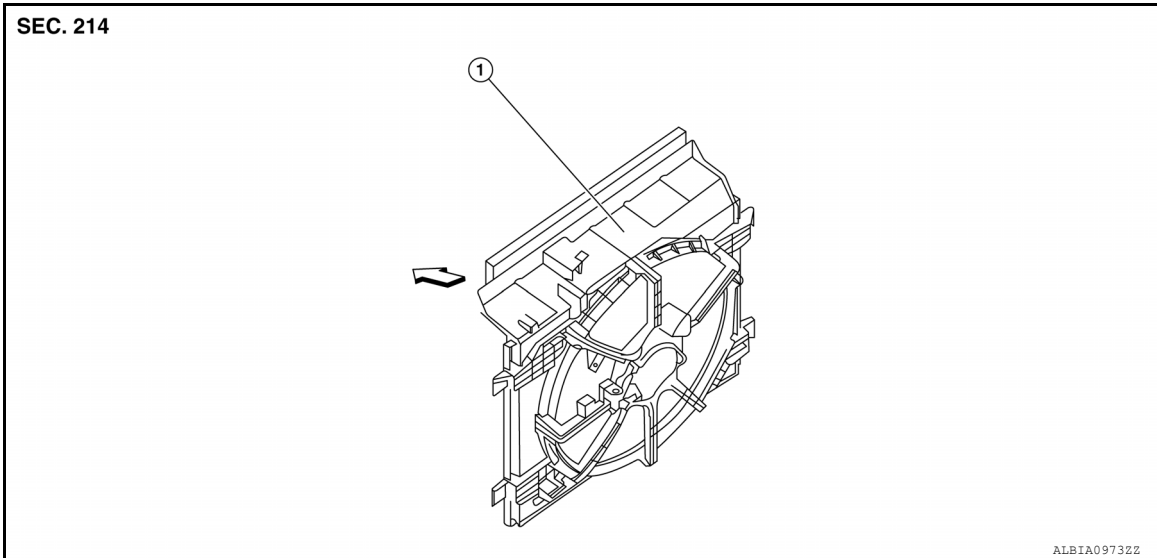

1. Fan shroud and motor assembly ↩ Front

Removal and Installation

INFOID:0000000011537135

WARNING:

Do not remove the radiator cap when the engine is hot. Serious burns could occur from high-pressure engine coolant escaping from the radiator. Wrap a thick cloth around the cap. Slowly push down and turn it a quarter turn to allow built-up pressure to escape. Carefully remove the cap by pushing it down and turning it all the way.

NOTE:

- When removing components such as hoses, tubes/lines, etc., cap or plug openings to prevent fluid from spilling.
- Replace the fan shroud and motor assembly as a unit. Do not replace cooling fan motor or cooling fan blade separately.

REMOVAL

1. Remove engine under cover. Refer to [EXT-16, "Exploded View"](#).
2. Partially drain engine coolant from the radiator. Refer to [CO-12, "Changing Engine Coolant"](#).

CAUTION:

- Perform this step when the engine is cold.
 - Do not spill engine coolant on the drive belt.
3. Remove the radiator core support upper cover clips (A) and screws (B), and remove.

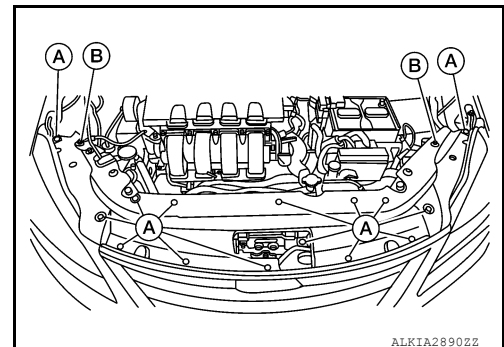

4. Remove the hood lock assembly from radiator core support (upper). Refer to [DLK-161, "HOOD LOCK CONTROL : Removal and Installation"](#).

COOLING FAN

[MRA8DE]

< REMOVAL AND INSTALLATION >

5. Remove the radiator core support (upper) bolts, then remove the radiator core support (upper). Refer to [CO-15, "Exploded View"](#).
6. Disconnect filler neck hose from radiator and radiator hose (upper) from water inlet.
7. Remove filler neck screws from fan shroud and motor assembly, then remove filler neck with attached hoses.
8. Remove reservoir tank and reservoir tank hose.
9. Disconnect the harness connector from fan shroud and motor assembly.
10. Remove fan shroud and motor assembly.

INSTALLATION

Installation is in the reverse order of removal.

- After installation refill engine coolant and check for leaks. Refer to [CO-12, "Changing Engine Coolant"](#) and [CO-11, "System Inspection"](#).

CAUTION:

- **Do not spill engine coolant in engine compartment. Use a shop cloth to absorb engine coolant.**
- Fan shroud and motor assembly is controlled by ECM. Refer to [EC-63, "On Board Diagnosis Function"](#).

WATER PUMP

< REMOVAL AND INSTALLATION >

[MRA8DE]

WATER PUMP

Exploded View

INFOID:000000011537136

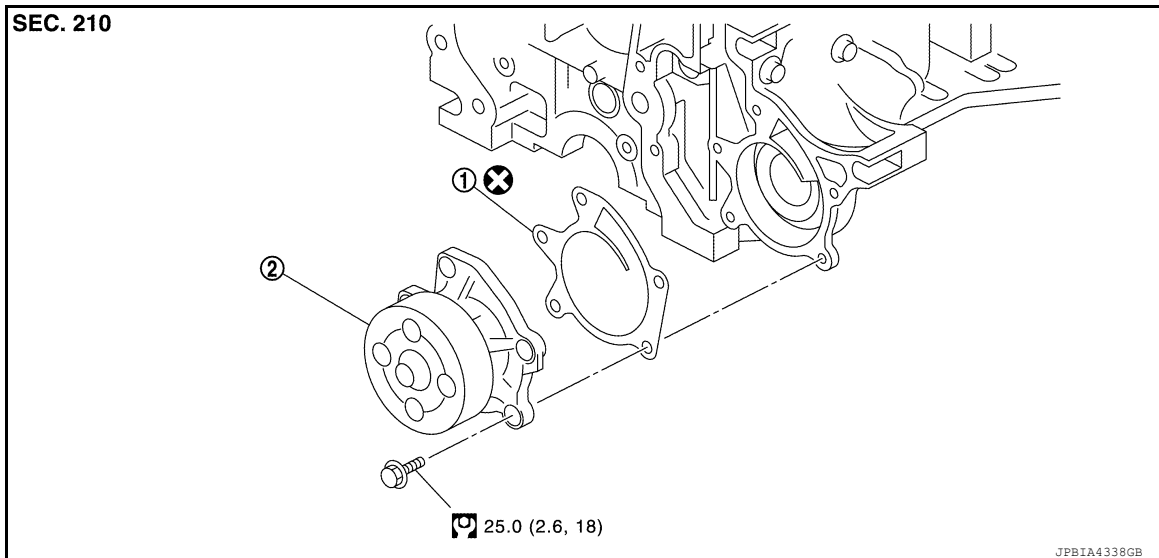

1. Gasket

2. Water pump

Removal and Installation

INFOID:000000011537137

WARNING:

Do not remove the radiator cap when the engine is hot. Serious burns could occur from high-pressure engine coolant escaping from the radiator. Wrap a thick cloth around the cap. Slowly push down and turn it a quarter turn to allow built-up pressure to escape. Carefully remove the cap by pushing it down and turning it all the way.

CAUTION:

- When removing water pump assembly, be careful not to get engine coolant on drive belt.
- Water pump cannot be disassembled and should be replaced as a unit.
- After installing water pump, connect hose and clamp securely, then check for leaks using radiator cap tester.

NOTE:

When removing components such as hoses, tubes/lines, etc., cap or plug openings to prevent fluid from spilling.

REMOVAL

1. Disconnect the negative battery terminal. Refer to [PG-74, "Removal and Installation \(Battery\)"](#).
 2. Remove fan shroud and motor assembly. Refer to [CO-17, "Removal and Installation"](#).
- CAUTION:**
- Perform this step when the engine is cold.
 - Do not spill engine coolant on the drive belt.
3. Partially remove front fender protector (RH). Refer to [EXT-28, "FENDER PROTECTOR : Exploded View"](#).
 4. Remove drive belt. Refer to [EM-15, "Removal and Installation"](#).
 5. Remove generator. Refer to [CHG-29, "Removal and Installation"](#).
 6. Remove water pump bolts, then remove water pump and gasket.
 - Engine coolant will leak from cylinder block, so have a receptacle ready below.

CAUTION:

- Handle water pump vane so that it does not contact any other parts.
- Water pump cannot be disassembled and should be replaced as an assembly.

INSTALLATION

Installation is in the reverse order of removal.

CAUTION:

WATER PUMP

< REMOVAL AND INSTALLATION >

[MRA8DE]

Do not reuse gasket.

THERMOSTAT AND THERMOSTAT HOUSING

< REMOVAL AND INSTALLATION >

[MRA8DE]

THERMOSTAT AND THERMOSTAT HOUSING

Exploded View

INFOID:000000011537138

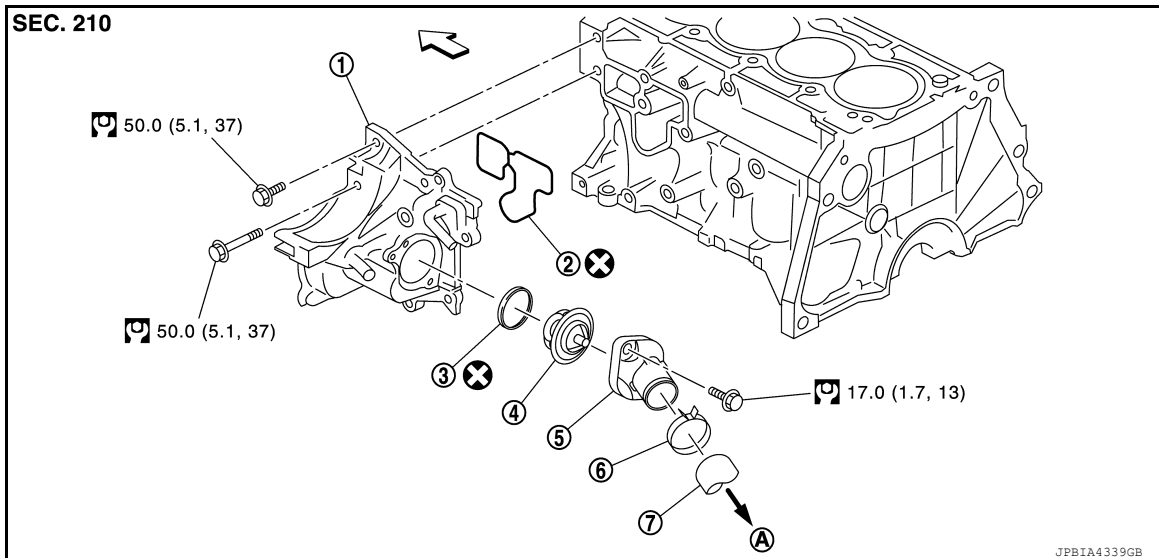

- | | | |
|--------------------------|----------------|----------------|
| 1. Thermostat housing | 2. Gasket | 3. Rubber ring |
| 4. Thermostat | 5. Water inlet | 6. Clamp |
| 7. Radiator hose (upper) | A. To radiator | ← Front |

Removal and Installation of Thermostat

INFOID:000000011537139

WARNING:

Do not remove the radiator cap when the engine is hot. Serious burns could occur from high-pressure engine coolant escaping from the radiator. Wrap a thick cloth around the cap. Slowly push down and turn it a quarter turn to allow built-up pressure to escape. Carefully remove the cap by pushing it down and turning it all the way.

NOTE:

When removing components such as hoses, tubes/lines, etc., cap or plug openings to prevent fluid from spilling.

REMOVAL

1. Remove engine under cover. Refer to [EXT-16, "Exploded View"](#).
2. Drain engine coolant from radiator. Refer to [CO-12, "Changing Engine Coolant"](#).

CAUTION:

- Perform this step when the engine is cold.
- Do not spill engine coolant on the drive belt.

3. Disconnect radiator hose (lower) from water inlet side. Refer to [CO-15, "Exploded View"](#).
4. Remove water inlet bolts, then remove water inlet and thermostat.

INSPECTION AFTER REMOVAL

THERMOSTAT AND THERMOSTAT HOUSING

[MRA8DE]

< REMOVAL AND INSTALLATION >

- Place a thread (A) so that it is caught in the valves of the thermostat (1). Immerse fully in a container (B) filled with water. Heat while stirring.
- The valve opening temperature is the temperature at which the valve opens and the thermostat falls from the thread.
- Continue heating. Check the full-open lift amount.

NOTE:

The full-open lift amount standard temperature for the thermostat is the reference value.

- After checking the full-open lift amount, lower the water temperature and check the valve closing temperature.

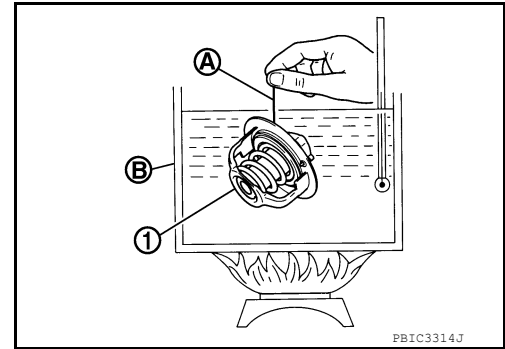

| Thermostat | Standard Values |
|---------------------------|--|
| Valve opening temperature | Refer to CO-27, "Thermostat" |
| Full-open lift amount | Refer to CO-27, "Thermostat" |
| Valve closing temperature | Refer to CO-27, "Thermostat" |

- If valve setting at measured values are out of standard range, replace thermostat.

INSTALLATION

Installation is in the reverse order of removal.

- Install the thermostat with the whole circumference of the flange (A) fitting securely inside the rubber ring (1).

CAUTION:

Do not reuse rubber ring.

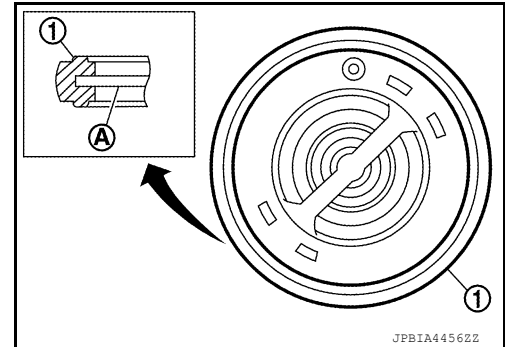

- Install the thermostat (2) into the thermostat housing (1) with the jiggle valve (A) facing upwards. The position deviation may be within the range of $\pm 10^\circ$.
- After installation, refill engine coolant and check for leaks. Refer to [CO-12, "Changing Engine Coolant"](#) and [CO-11, "System Inspection"](#).

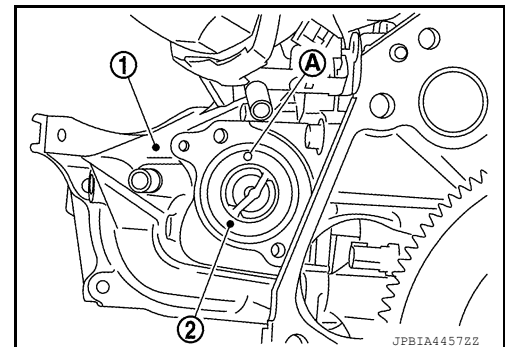

Removal and Installation of Thermostat Housing

INFOID:000000011537140

REMOVAL

1. Remove the generator. Refer to [CHG-29, "Removal and Installation"](#).
2. Partially remove the fender protector (LH). Refer to [EXT-29, "FENDER PROTECTOR : Removal and Installation - Front Fender Protector"](#).
3. Remove the thermostat housing bolts, then remove the thermostat housing.
4. Remove thermostat (if necessary). Refer to [CO-21, "Removal and Installation of Thermostat"](#).
5. Remove water pump (if necessary). Refer to [CO-19, "Removal and Installation"](#).

INSTALLATION

Installation is in the reverse order of removal.

CAUTION:

- **Do not reuse gasket.**

THERMOSTAT AND THERMOSTAT HOUSING

< REMOVAL AND INSTALLATION >

[MRA8DE]

- Do not spill engine coolant on the drive belt.

Inspection

INFOID:000000011537141

INSPECTION AFTER INSTALLATION

After installation, refill engine coolant and check for leaks. Refer to [CO-11, "System Inspection"](#) and [CO-12, "Changing Engine Coolant"](#).

A

CO

C

D

E

F

G

H

I

J

K

L

M

N

O

P

WATER OUTLET

< REMOVAL AND INSTALLATION >

[MRA8DE]

WATER OUTLET

Exploded View

INFOID:000000011537142

CVT MODELS

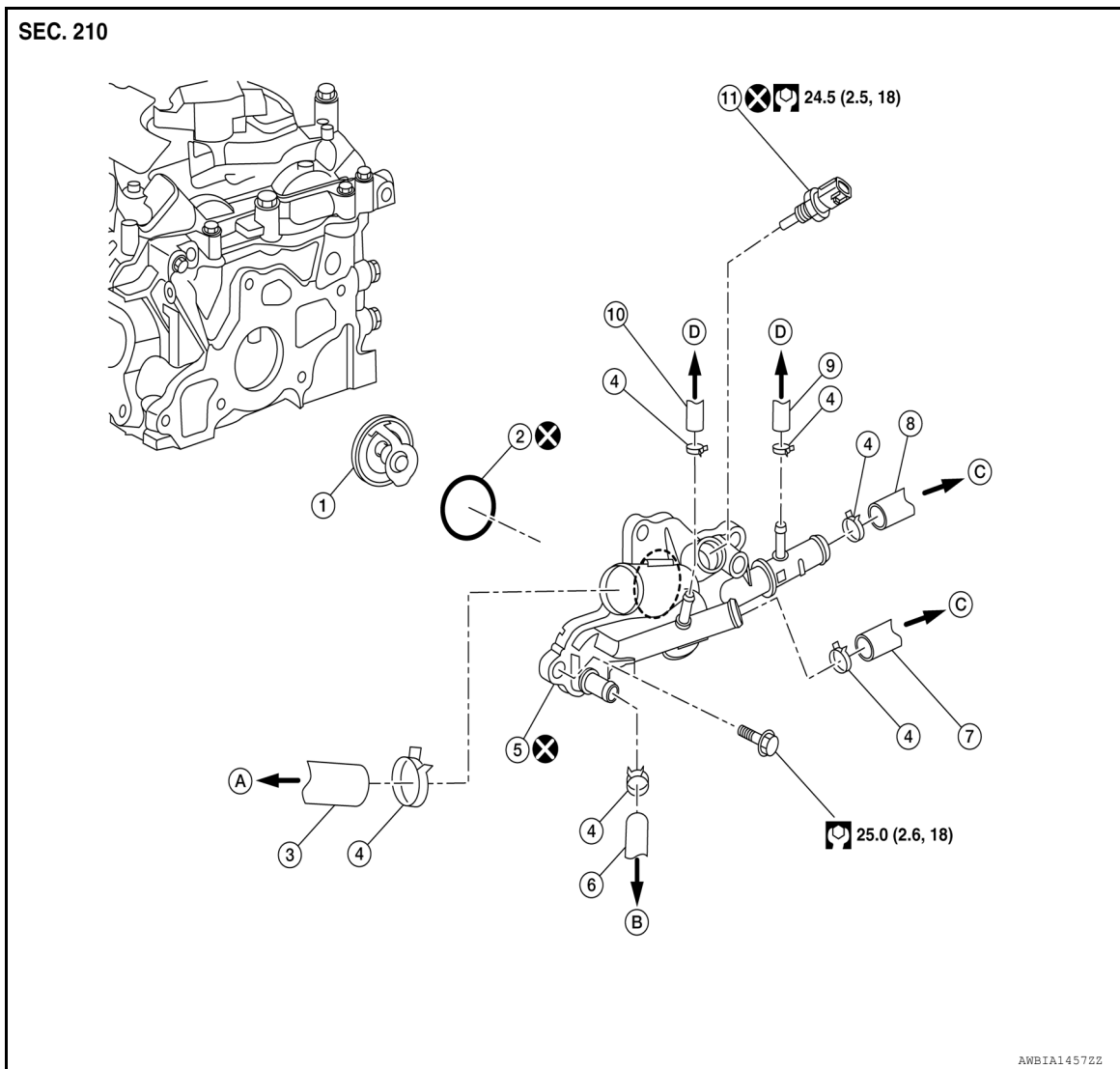

- | | | |
|---|---------------------------------------|---|
| 1. Water control valve | 2. Rubber ring | 3. Radiator hose (upper) |
| 4. Clamp | 5. Water outlet | 6. CVT oil warmer hose (outlet) |
| 7. Heater hose (inlet) | 8. Heater hose (outlet) | 9. Electric throttle control actuator hose (outlet) |
| 10. Electric throttle control actuator hose (inlet) | 11. Engine coolant temperature sensor | A. To filler neck |
| B. To CVT oil warmer | C. To heater core | D. To electric throttle control actuator |

WATER OUTLET

< REMOVAL AND INSTALLATION >

[MRA8DE]

M/T MODELS

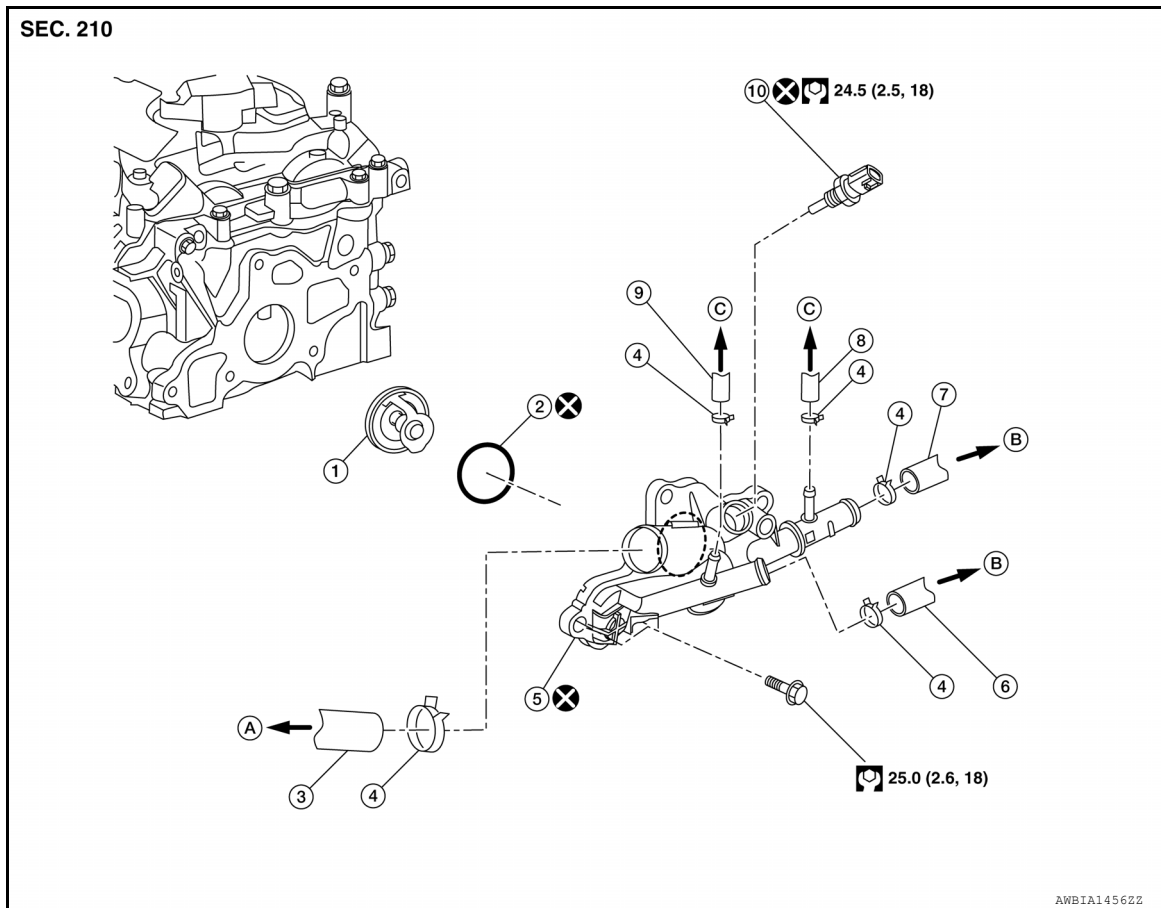

- | | | |
|--|---|--|
| 1. Water control valve | 2. Rubber ring | 3. Radiator hose (upper) |
| 4. Clamp | 5. Water outlet | 6. Heater hose (inlet) |
| 7. Heater hose (outlet) | 8. Electric throttle control actuator hose (outlet) | 9. Electric throttle control actuator hose (inlet) |
| 10. Engine coolant temperature sensor | A. To filler neck | B. To heater core |
| C. To electric throttle control actuator | | |

Removal and Installation

INFOID:000000011537143

WARNING:

Do not remove the radiator cap when the engine is hot. Serious burns could occur from high-pressure engine coolant escaping from the radiator. Wrap a thick cloth around the cap. Slowly push down and turn it a quarter turn to allow built-up pressure to escape. Carefully remove the cap by pushing it down and turning it all the way.

NOTE:

When removing components such as hoses, tubes/lines, etc., cap or plug openings to prevent fluid from spilling.

REMOVAL

1. Remove the battery. Refer to [PG-74, "Removal and Installation \(Battery\)"](#).
2. Drain engine coolant from radiator. Refer to [CO-12, "Changing Engine Coolant"](#).

CAUTION:

- Perform this step when the engine is cold.
 - Do not spill engine coolant on the drive belt.
3. Remove air cleaner and air duct. [EM-25, "Removal and Installation"](#).
 4. Disconnect the harness connector from engine coolant temperature sensor.
 5. Remove radiator hose (upper), water hoses and heater hoses from water outlet.
 6. Remove water outlet bolts and remove water outlet and rubber ring with water control valve.

WATER OUTLET

[MRA8DE]

< REMOVAL AND INSTALLATION >

7. Remove engine coolant temperature sensor from water outlet (if necessary).

INSPECTION AFTER REMOVAL

- Place a thread (A) so that it is caught in the valves of the water control valve (1). Immerse fully in a container (B) filled with water. Heat while stirring.
- The valve opening temperature is the temperature at which the valve opens and the water control valve falls from the thread.
- Continue heating. Check the full-open lift amount.

NOTE:

The full-open lift amount standard temperature for the water control valve is the reference value.

- After checking the full-open lift amount, lower the water temperature and check the valve closing temperature.

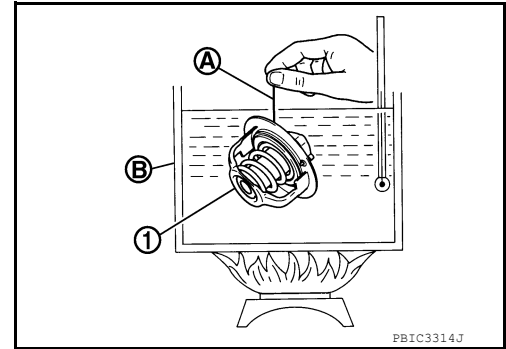

| water control valve | Standard Values |
|---------------------------|--|
| Valve opening temperature | Refer to CO-27, "Thermostat" |
| Full-open lift amount | Refer to CO-27, "Thermostat" |
| Valve closing temperature | Refer to CO-27, "Thermostat" |

- If valve setting at measured values are out of standard range, replace water control valve.

INSTALLATION

Installation is in the reverse order of removal.

Install the engine coolant temperature sensor (if removed).

Use Genuine RTV Silicone Sealant or equivalent. Refer to [MA-11, "Fluids and Lubricants"](#).

CAUTION:

- Do not reuse rubber-ring.
- Do not reuse water outlet.
- If removed, do not reuse engine coolant temperature sensor.
- Do not spill engine coolant in engine compartment. Use a shop cloth to absorb engine coolant.
- Install water control valve with the rubber ring (1) groove fit onto water control valve flange (A).

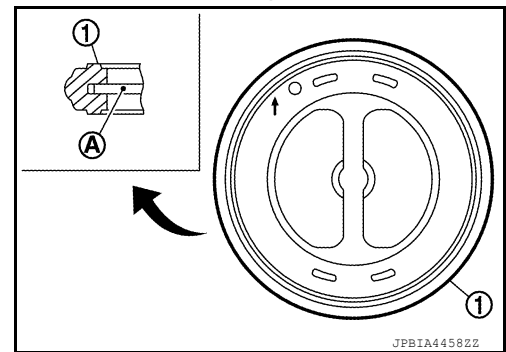

- Install water control valve (2) with the arrow (A) facing up, and the frame center part (B) facing engine.

(1) : Water outlet

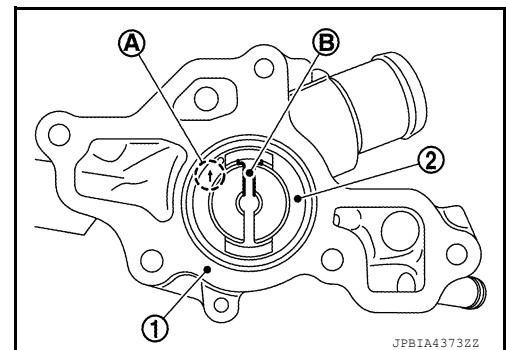

INSPECTION AFTER INSTALLATION

After installation, refill engine coolant and check for leaks. Refer to [CO-11, "System Inspection"](#) and [CO-12, "Changing Engine Coolant"](#).

SERVICE DATA AND SPECIFICATIONS (SDS)

< SERVICE DATA AND SPECIFICATIONS (SDS)

[MRA8DE]

SERVICE DATA AND SPECIFICATIONS (SDS)

SERVICE DATA AND SPECIFICATIONS (SDS)

Periodical Maintenance Specification

INFOID:0000000011537144

ENGINE COOLANT CAPACITY (APPROXIMATE)

Unit: ℓ (US qt, Imp qt)

| | | |
|--|------------|----------------|
| Engine coolant capacity (With reservoir tank at "MAX" level) | CVT models | 6.6 (7, 5-7/8) |
| | M/T models | |
| Reservoir tank engine coolant capacity (At "MAX" level) | | 0.6 (5/8, 1/2) |

Radiator

INFOID:0000000011537145

Unit: kPa (kg/cm², psi)

| | | |
|--------------------------|----------|-------------------------------------|
| Cap relief pressure | Standard | 88 ± 9.8 (0.90 ± 0.10, 12.8 ± 1.42) |
| | Llimit | 59 (0.6, 9) |
| Leakage testing pressure | | 156 (1.6, 23) |

Thermostat

INFOID:0000000011537146

Standard

| | |
|---------------------------|------------------------------|
| Valve opening temperature | 80.5 - 83.5°C (177 - 182°F) |
| Maximum valve lift | 8.0 mm/95°C (0.315 in/203°F) |
| Valve closing temperature | 77°C (171°F) |

Water Control Valve

INFOID:0000000011537147

Standard

| | |
|---------------------------|-------------------------------|
| Valve opening temperature | 93.5 - 96.5°C (200 - 206°F) |
| Maximum valve lift | 8.0 mm/108°C (0.315 in/226°F) |
| Valve closing temperature | 90°C (194°F) |