

A  
B  
C

# SECTION **GW**

## GLASS & WINDOW SYSTEM

### CONTENTS

<p><b>PRECAUTION</b> ..... 2</p> <p><b>PRECAUTIONS</b> ..... 2</p> <p style="padding-left: 20px;">Precaution for Supplemental Restraint System (SRS) "AIR BAG" and "SEAT BELT PRE-TENSIONER" .....2</p> <p style="padding-left: 20px;">Procedure without Cowl Top Cover .....2</p> <p style="padding-left: 20px;">Handling for Adhesive and Primer .....2</p> <p style="padding-left: 20px;">Precaution for Work .....2</p> <p><b>PREPARATION</b> ..... 4</p> <p><b>PREPARATION</b> ..... 4</p> <p style="padding-left: 20px;">Special Service Tools .....4</p> <p style="padding-left: 20px;">Commercial Service Tools .....4</p> <p><b>SYMPTOM DIAGNOSIS</b> ..... 5</p> <p><b>SQUEAK AND RATTLE TROUBLE DIAGNOSES</b> ..... 5</p> <p style="padding-left: 20px;">Work Flow .....5</p> <p style="padding-left: 20px;">Generic Squeak and Rattle Troubleshooting .....6</p> <p style="padding-left: 20px;">Diagnostic Worksheet .....9</p> <p><b>REMOVAL AND INSTALLATION</b> .....11</p> <p><b>WINDSHIELD GLASS</b> .....11</p> <p style="padding-left: 20px;">Exploded View ..... 11</p> <p style="padding-left: 20px;">Removal and Installation ..... 12</p>	<p style="text-align: right;">D E F G H I J GW L M N O P</p> <p><b>FRONT DOOR GLASS</b> .....14</p> <p style="padding-left: 20px;">Removal and Installation .....14</p> <p style="padding-left: 20px;">Inspection and Adjustment .....14</p> <p><b>FRONT REGULATOR</b> .....16</p> <p style="padding-left: 20px;">Exploded View .....16</p> <p style="padding-left: 20px;">Removal and Installation .....16</p> <p style="padding-left: 20px;">Inspection and Adjustment .....17</p> <p><b>FRONT POWER WINDOW MOTOR</b> .....19</p> <p style="padding-left: 20px;">Removal and Installation .....19</p> <p><b>REAR DOOR GLASS</b> .....20</p> <p style="padding-left: 20px;">Removal and Installation .....20</p> <p><b>REAR REGULATOR</b> .....21</p> <p style="padding-left: 20px;">Exploded View .....21</p> <p style="padding-left: 20px;">Removal and Installation .....21</p> <p><b>REAR POWER WINDOW MOTOR</b> .....23</p> <p style="padding-left: 20px;">Removal and Installation .....23</p> <p><b>SIDE WINDOW GLASS</b> .....24</p> <p style="padding-left: 20px;">Components .....24</p> <p style="padding-left: 20px;">Removal and Installation .....24</p> <p><b>REAR WINDOW GLASS</b> .....26</p> <p style="padding-left: 20px;">Exploded View .....26</p> <p style="padding-left: 20px;">Removal and Installation .....26</p>
------------------------------------------------------------------------------------------------------------------------------------------------------------------------------------------------------------------------------------------------------------------------------------------------------------------------------------------------------------------------------------------------------------------------------------------------------------------------------------------------------------------------------------------------------------------------------------------------------------------------------------------------------------------------------------------------------------------------------------------------------------------------------------------------------------------------------------------------------------------------------------------------------------------------------------------------------------------------------------------------------------------------------------------------------------------------------------------------------------------------------------------------------------------	----------------------------------------------------------------------------------------------------------------------------------------------------------------------------------------------------------------------------------------------------------------------------------------------------------------------------------------------------------------------------------------------------------------------------------------------------------------------------------------------------------------------------------------------------------------------------------------------------------------------------------------------------------------------------------------------------------------------------------------------------------------------------------------------------------------------------------------------------------------------------------------------------------------------------------------------------------------------------------------------------------------------------------------------------------------------------------------------------------------------------------------------------------------------------------------------------------------------------------------------------------------------------------------------------------------------------------------------------------------------------------------------

# PRECAUTIONS

< PRECAUTION >

## PRECAUTION

### PRECAUTIONS

#### Precaution for Supplemental Restraint System (SRS) "AIR BAG" and "SEAT BELT PRE-TENSIONER"

INFOID:000000012783566

The Supplemental Restraint System such as "AIR BAG" and "SEAT BELT PRE-TENSIONER", used along with a front seat belt, helps to reduce the risk or severity of injury to the driver and front passenger for certain types of collision. Information necessary to service the system safely is included in the SR and SB section of this Service Manual.

#### **WARNING:**

- To avoid rendering the SRS inoperative, which could increase the risk of personal injury or death in the event of a collision which would result in air bag inflation, it is recommended that all maintenance and repair be performed by an authorized NISSAN/INFINITI dealer.
- Improper repair, including incorrect removal and installation of the SRS, can lead to personal injury caused by unintentional activation of the system. For removal of Spiral Cable and Air Bag Module, see the SR section.
- Do not use electrical test equipment on any circuit related to the SRS unless instructed to in this Service Manual. SRS wiring harnesses can be identified by yellow and/or orange harnesses or harness connectors.

#### PRECAUTIONS WHEN USING POWER TOOLS (AIR OR ELECTRIC) AND HAMMERS

#### **WARNING:**

- When working near the Air Bag Diagnosis Sensor Unit or other Air Bag System sensors with the Ignition ON or engine running, DO NOT use air or electric power tools or strike near the sensor(s) with a hammer. Heavy vibration could activate the sensor(s) and deploy the air bag(s), possibly causing serious injury.
- When using air or electric power tools or hammers, always switch the Ignition OFF, disconnect the battery or batteries, and wait at least three minutes before performing any service.

#### Procedure without Cowl Top Cover

INFOID:000000012783567

When performing the procedure after removing cowl top cover, cover the lower end of windshield with urethane, etc.

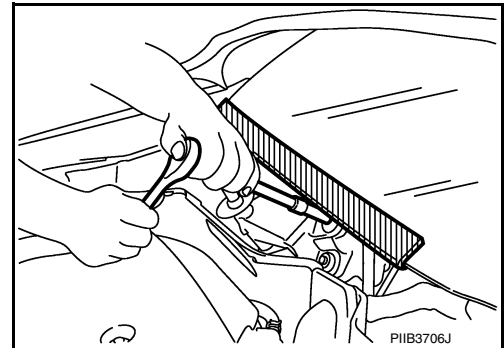

#### Handling for Adhesive and Primer

INFOID:000000012783568

- Do not use an adhesive which is past its usable date. Shelf life of this product is limited to six months after the date of manufacture. Carefully adhere to the expiration or manufacture date printed on the box.
- Keep primers and adhesive in a cool, dry place. Ideally, they should be stored in a refrigerator.
- Open the seal of the primer and adhesive just before application. Discard the remainder.
- Before application, be sure to shake the primer container to stir the contents. If any floating material is found, do not use it.
- If any primer or adhesive contacts the skin, wipe it off with gasoline or equivalent and wash the skin with soap.
- When using primer and adhesive, always observe the precautions in the instruction manual.

#### Precaution for Work

INFOID:000000012783569

- When removing or disassembling each component, be careful not to damage or deform it. If a component may be subject to interference, be sure to protect it with a shop cloth.

## PRECAUTIONS

### < PRECAUTION >

- When removing (disengaging) components with a screwdriver or similar tool, be sure to wrap the component with a shop cloth or vinyl tape to protect it. A
- Protect the removed parts with a shop cloth and prevent them from being dropped.
- Replace a deformed or damaged clip.
- If a part is specified as a non-reusable part, always replace it with a new one. B
- Be sure to tighten bolts and nuts securely to the specified torque.
- After installation is complete, be sure to check that each part works properly.
- Follow the steps below to clean components:
  - Water soluble dirt: C
  - Dip a soft cloth into lukewarm water, wring the water out of the cloth and wipe the dirty area.
  - Then rub with a soft, dry cloth.
  - Oily dirt: D
  - Dip a soft cloth into lukewarm water with mild detergent (concentration: within 2 to 3%) and wipe the dirty area.
  - Then dip a cloth into fresh water, wring the water out of the cloth and wipe the detergent off. E
  - Then rub with a soft, dry cloth.
  - Do not use organic solvent such as thinner, benzene, alcohol or gasoline.
  - For genuine leather seats, use a genuine leather seat cleaner. F

A

B

C

D

E

F

G

H

I

J

GW

L

M

N

O

P

# PREPARATION

< PREPARATION >

## PREPARATION

### PREPARATION

#### Special Service Tools

INFOID:000000012783570

The actual shape of the tools may differ from those illustrated here.

Tool number (TechMate No.) Tool name	Description
— (J-39570) Chassis Ear	Locating the noise
— (J-50397) NISSAN Squeak and Rattle Kit	Repairing the cause of noise
— (J-46534) Trim Tool Set	Removing trim components

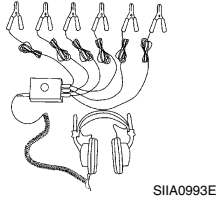

SIA0993E



ALJIA1232ZZ

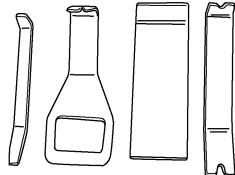

AWJIA0483ZZ

#### Commercial Service Tools

INFOID:000000012783571

(TechMate No.) Tool name	Description
(J-39565) Engine Ear	Locating the noise
( — ) Suction Lifter	Holding the door glass

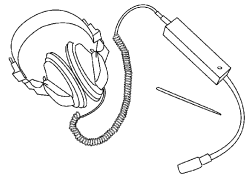

SIA0995E

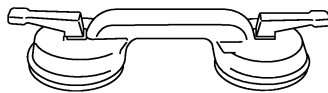

PIIB1805J

# SQUEAK AND RATTLE TROUBLE DIAGNOSES

< SYMPTOM DIAGNOSIS >

## SYMPTOM DIAGNOSIS

### SQUEAK AND RATTLE TROUBLE DIAGNOSES

#### Work Flow

INFOID:0000000012783572

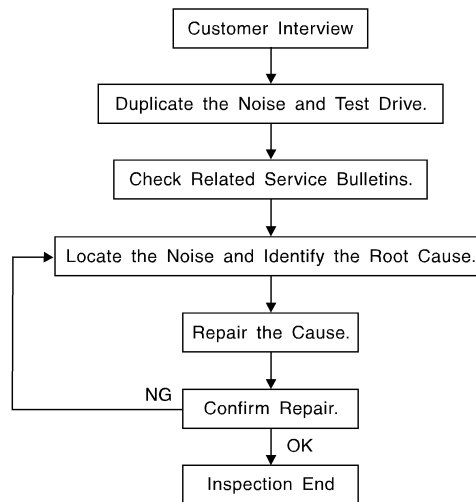

SBT842

#### CUSTOMER INTERVIEW

Interview the customer if possible, to determine the conditions that exist when the noise occurs. Use the Diagnostic Worksheet during the interview to document the facts and conditions when the noise occurs and any customer's comments; refer to [GW-9, "Diagnostic Worksheet"](#). This information is necessary to duplicate the conditions that exist when the noise occurs.

- The customer may not be able to provide a detailed description or the location of the noise. Attempt to obtain all the facts and conditions that exist when the noise occurs (or does not occur).
- If there is more than one noise in the vehicle, be sure to diagnose and repair the noise that the customer is concerned about. This can be accomplished by test driving the vehicle with the customer.
- After identifying the type of noise, isolate the noise in terms of its characteristics. The noise characteristics are provided so the customer, service adviser and technician are all speaking the same language when defining the noise.
- Squeak —(Like tennis shoes on a clean floor)  
Squeak characteristics include the light contact/fast movement/brought on by road conditions/hard surfaces = higher pitch noise/softer surfaces = lower pitch noises/edge to surface = chirping.
- Creak—(Like walking on an old wooden floor)  
Creak characteristics include firm contact/slow movement/twisting with a rotational movement/pitch dependent on materials/often brought on by activity.
- Rattle—(Like shaking a baby rattle)  
Rattle characteristics include the fast repeated contact/vibration or similar movement/loose parts/missing clip or fastener/incorrect clearance.
- Knock —(Like a knock on a door)  
Knock characteristics include hollow sounding/sometimes repeating/often brought on by driver action.
- Tick—(Like a clock second hand)  
Tick characteristics include gentle contacting of light materials/loose components/can be caused by driver action or road conditions.
- Thump—(Heavy, muffled knock noise)  
Thump characteristics include softer knock/dead sound often brought on by activity.
- Buzz—(Like a bumble bee)  
Buzz characteristics include high frequency rattle/firm contact.
- Often the degree of acceptable noise level will vary depending upon the person. A noise that you may judge as acceptable may be very irritating to the customer.
- Weather conditions, especially humidity and temperature, may have a great effect on noise level.

#### DUPLICATE THE NOISE AND TEST DRIVE

# SQUEAK AND RATTLE TROUBLE DIAGNOSES

## < SYMPTOM DIAGNOSIS >

If possible, drive the vehicle with the customer until the noise is duplicated. Note any additional information on the Diagnostic Worksheet regarding the conditions or location of the noise. This information can be used to duplicate the same conditions when you confirm the repair.

If the noise can be duplicated easily during the test drive, to help identify the source of the noise, try to duplicate the noise with the vehicle stopped by doing one or all of the following:

- 1) Close a door.
  - 2) Tap or push/pull around the area where the noise appears to be coming from.
  - 3) Rev the engine.
  - 4) Use a floor jack to recreate vehicle "twist".
  - 5) At idle, apply engine load (electrical load, half-clutch on M/T model, drive position on CVT and A/T models).
  - 6) Raise the vehicle on a hoist and hit a tire with a rubber hammer.
- Drive the vehicle and attempt to duplicate the conditions the customer states exist when the noise occurs.
  - If it is difficult to duplicate the noise, drive the vehicle slowly on an undulating or rough road to stress the vehicle body.

## CHECK RELATED SERVICE BULLETINS

After verifying the customer concern or symptom, check ASIST for Technical Service Bulletins (TSBs) related to that concern or symptom.

If a TSB relates to the symptom, follow the procedure to repair the noise.

## LOCATE THE NOISE AND IDENTIFY THE ROOT CAUSE

1. Narrow down the noise to a general area. To help pinpoint the source of the noise, use a listening tool (Chassis Ear: J-39570, Engine Ear: J-39565 and mechanic's stethoscope).
2. Narrow down the noise to a more specific area and identify the cause of the noise by:
  - removing the components in the area that you suspect the noise is coming from.  
Do not use too much force when removing clips and fasteners, otherwise clips and fasteners can be broken or lost during the repair, resulting in the creation of new noise.
  - tapping or pushing/pulling the component that you suspect is causing the noise.  
Do not tap or push/pull the component with excessive force, otherwise the noise will be eliminated only temporarily.
  - feeling for a vibration with your hand by touching the component(s) that you suspect is (are) causing the noise.
  - placing a piece of paper between components that you suspect are causing the noise.
  - looking for loose components and contact marks.  
Refer to [GW-6, "Generic Squeak and Rattle Troubleshooting"](#).

## REPAIR THE CAUSE

- If the cause is a loose component, tighten the component securely.
- If the cause is insufficient clearance between components:
  - separate components by repositioning or loosening and retightening the component, if possible.
  - insulate components with a suitable insulator such as urethane pads, foam blocks, felt cloth tape or urethane tape. A NISSAN Squeak and Rattle Kit (J-50397) is available through your authorized NISSAN Parts Department.

### **CAUTION:**

**Do not use excessive force as many components are constructed of plastic and may be damaged.**

### **NOTE:**

- Always check with the Parts Department for the latest parts information.
- The materials contained in the NISSAN Squeak and Rattle Kit (J-50397) are listed on the inside cover of the kit; and can each be ordered separately as needed.
- The following materials not found in the kit can also be used to repair squeaks and rattles.
  - SILICONE GREASE: Use instead of UHMW tape that will be visible or does not fit. The silicone grease will only last a few months.
  - SILICONE SPRAY: Use when grease cannot be applied.
  - DUCT TAPE: Use to eliminate movement.

## CONFIRM THE REPAIR

Confirm that the cause of a noise is repaired by test driving the vehicle. Operate the vehicle under the same conditions as when the noise originally occurred. Refer to the notes on the Diagnostic Worksheet.

## Generic Squeak and Rattle Troubleshooting

INFOID:000000012783573

Refer to Table of Contents for specific component removal and installation information.

# SQUEAK AND RATTLE TROUBLE DIAGNOSES

## < SYMPTOM DIAGNOSIS >

### INSTRUMENT PANEL

Most incidents are caused by contact and movement between:

1. Cluster lid A and the instrument panel
2. Acrylic lens and combination meter housing
3. Instrument panel to front pillar finisher
4. Instrument panel to windshield
5. Instrument panel pins
6. Wiring harnesses behind the combination meter
7. A/C defroster duct and duct joint

These incidents can usually be located by tapping or moving the components to duplicate the noise or by pressing on the components while driving to stop the noise. Most of these incidents can be repaired by applying felt cloth tape or silicone spray (in hard to reach areas). Urethane pads can be used to insulate wiring harness.

#### **CAUTION:**

**Do not use silicone spray to isolate a squeak or rattle. If you saturate the area with silicone, you will not be able to recheck the repair.**

### CENTER CONSOLE

Components to pay attention to include:

1. Shift selector assembly cover to finisher
2. A/C control unit and cluster lid C
3. Wiring harnesses behind audio and A/C control unit

The instrument panel repair and isolation procedures also apply to the center console.

### DOORS

Pay attention to the:

1. Finisher and inner panel making a slapping noise
2. Inside handle escutcheon to door finisher
3. Wiring harnesses tapping
4. Door striker out of alignment causing a popping noise on starts and stops

Tapping or moving the components or pressing on them while driving to duplicate the conditions can isolate many of these incidents. You can usually insulate the areas with felt cloth tape or insulator foam blocks from the NISSAN Squeak and Rattle Kit (J-50397) to repair the noise.

### TRUNK

Trunk noises are often caused by a loose jack or loose items put into the trunk by the owner.

In addition look for:

1. Trunk lid bumpers out of adjustment
2. Trunk lid striker out of adjustment
3. The trunk lid torsion bars knocking together
4. A loose license plate or bracket

Most of these incidents can be repaired by adjusting, securing or insulating the item(s) or component(s) causing the noise.

### SUNROOF/HEADLINING

Noises in the sunroof/headlining area can often be traced to one of the following:

1. Sunroof lid, rail, linkage or seals making a rattle or light knocking noise
2. Sun visor shaft shaking in the holder
3. Front or rear windshield touching headlining and squeaking

Again, pressing on the components to stop the noise while duplicating the conditions can isolate most of these incidents. Repairs usually consist of insulating with felt cloth tape.

### OVERHEAD CONSOLE (FRONT AND REAR)

Overhead console noises are often caused by the console panel clips not being engaged correctly. Most of these incidents are repaired by pushing up on the console at the clip locations until the clips engage.

In addition look for:

A

B

C

D

E

F

G

H

I

J

GW

L

M

N

O

P

# SQUEAK AND RATTLE TROUBLE DIAGNOSES

## < SYMPTOM DIAGNOSIS >

---

1. Loose harness or harness connectors.
2. Front console map/reading lamp lens loose.
3. Loose screws at console attachment points.

## SEATS

When isolating seat noise it's important to note the position the seat is in and the load placed on the seat when the noise is present. These conditions should be duplicated when verifying and isolating the cause of the noise.

Cause of seat noise include:

1. Headrest rods and holder
2. A squeak between the seat pad cushion and frame
3. The rear seatback lock and bracket

These noises can be isolated by moving or pressing on the suspected components while duplicating the conditions under which the noise occurs. Most of these incidents can be repaired by repositioning the component or applying urethane tape to the contact area.

## UNDERHOOD

Some interior noise may be caused by components under the hood or on the engine wall. The noise is then transmitted into the passenger compartment.

Causes of transmitted underhood noise include:

1. Any component installed to the engine wall
2. Components that pass through the engine wall
3. Engine wall mounts and connectors
4. Loose radiator installation pins
5. Hood bumpers out of adjustment
6. Hood striker out of adjustment

These noises can be difficult to isolate since they cannot be reached from the interior of the vehicle. The best method is to secure, move or insulate one component at a time and test drive the vehicle. Also, engine rpm or load can be changed to isolate the noise. Repairs can usually be made by moving, adjusting, securing, or insulating the component causing the noise.



# SQUEAK AND RATTLE TROUBLE DIAGNOSES

< SYMPTOM DIAGNOSIS >

## Diagnostic Worksheet

INFOID:000000012783574

Dear Customer:

We are concerned about your satisfaction with your vehicle. Repairing a squeak or rattle sometimes can be very difficult. To help us fix your vehicle right the first time, please take a moment to note the area of the vehicle where the squeak or rattle occurs and under what conditions. You may be asked to take a test drive with a service advisor or technician to ensure we confirm the noise you are hearing.

### SQUEAK & RATTLE DIAGNOSTIC WORKSHEET

#### I. WHERE DOES THE NOISE COME FROM? (circle the area of the vehicle)

The illustrations are for reference only, and may not reflect the actual configuration of your vehicle.

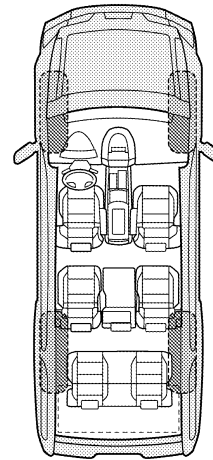
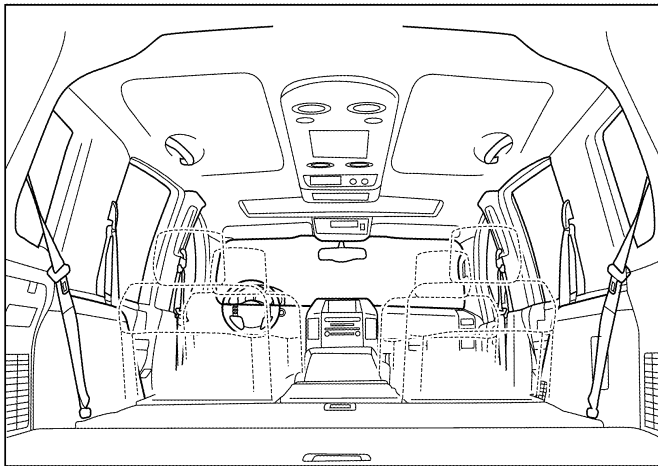
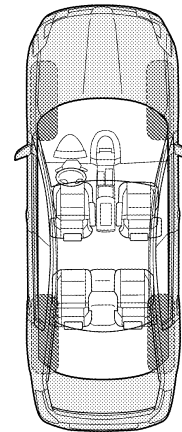
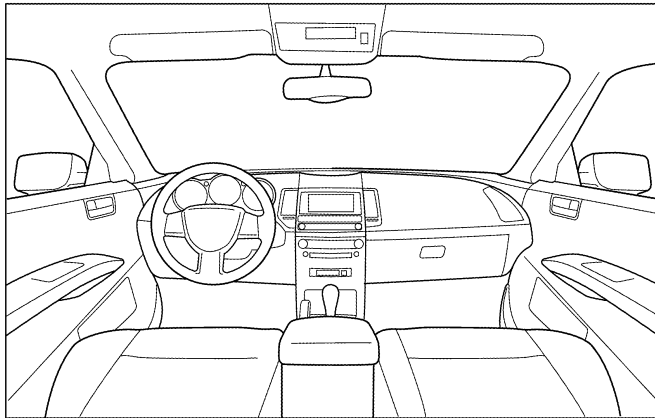

Continue to page 2 of the worksheet and briefly describe the location of the noise or rattle. In addition, please indicate the conditions which are present when the noise occurs.

A  
B  
C  
D  
E  
F  
G  
H  
I  
J  
GW  
L  
M  
N  
O  
P

# SQUEAK AND RATTLE TROUBLE DIAGNOSES

< SYMPTOM DIAGNOSIS >

## SQUEAK & RATTLE DIAGNOSTIC WORKSHEET - page 2

Briefly describe the location where the noise occurs:

\_\_\_\_\_

\_\_\_\_\_

### II. WHEN DOES IT OCCUR? (please check the boxes that apply)

- |                                                       |                                                        |
|-------------------------------------------------------|--------------------------------------------------------|
| <input type="checkbox"/> Anytime                      | <input type="checkbox"/> After sitting out in the rain |
| <input type="checkbox"/> 1st time in the morning      | <input type="checkbox"/> When it is raining or wet     |
| <input type="checkbox"/> Only when it is cold outside | <input type="checkbox"/> Dry or dusty conditions       |
| <input type="checkbox"/> Only when it is hot outside  | <input type="checkbox"/> Other:                        |

### III. WHEN DRIVING:

- Through driveways
- Over rough roads
- Over speed bumps
- Only about \_\_\_\_ mph
- On acceleration
- Coming to a stop
- On turns: left, right or either (circle)
- With passengers or cargo
- Other: \_\_\_\_\_
- After driving \_\_\_\_ miles or \_\_\_\_ minutes

### IV. WHAT TYPE OF NOISE

- Squeak (like tennis shoes on a clean floor)
- Creak (like walking on an old wooden floor)
- Rattle (like shaking a baby rattle)
- Knock (like a knock at the door)
- Tick (like a clock second hand)
- Thump (heavy muffled knock noise)
- Buzz (like a bumble bee)

### TO BE COMPLETED BY DEALERSHIP PERSONNEL

Test Drive Notes:

\_\_\_\_\_

\_\_\_\_\_

\_\_\_\_\_

	YES	NO	Initials of person performing
Vehicle test driven with customer	<input type="checkbox"/>	<input type="checkbox"/>	_____
- Noise verified on test drive	<input type="checkbox"/>	<input type="checkbox"/>	_____
- Noise source located and repaired	<input type="checkbox"/>	<input type="checkbox"/>	_____
- Follow up test drive performed to confirm repair	<input type="checkbox"/>	<input type="checkbox"/>	_____

VIN: \_\_\_\_\_ Customer Name \_\_\_\_\_

W.O.# \_\_\_\_\_ Date: \_\_\_\_\_

This form must be attached to Work Order

LAI0071E

# WINDSHIELD GLASS

< REMOVAL AND INSTALLATION >

## REMOVAL AND INSTALLATION

### WINDSHIELD GLASS

Exploded View

INFOID:000000012783575

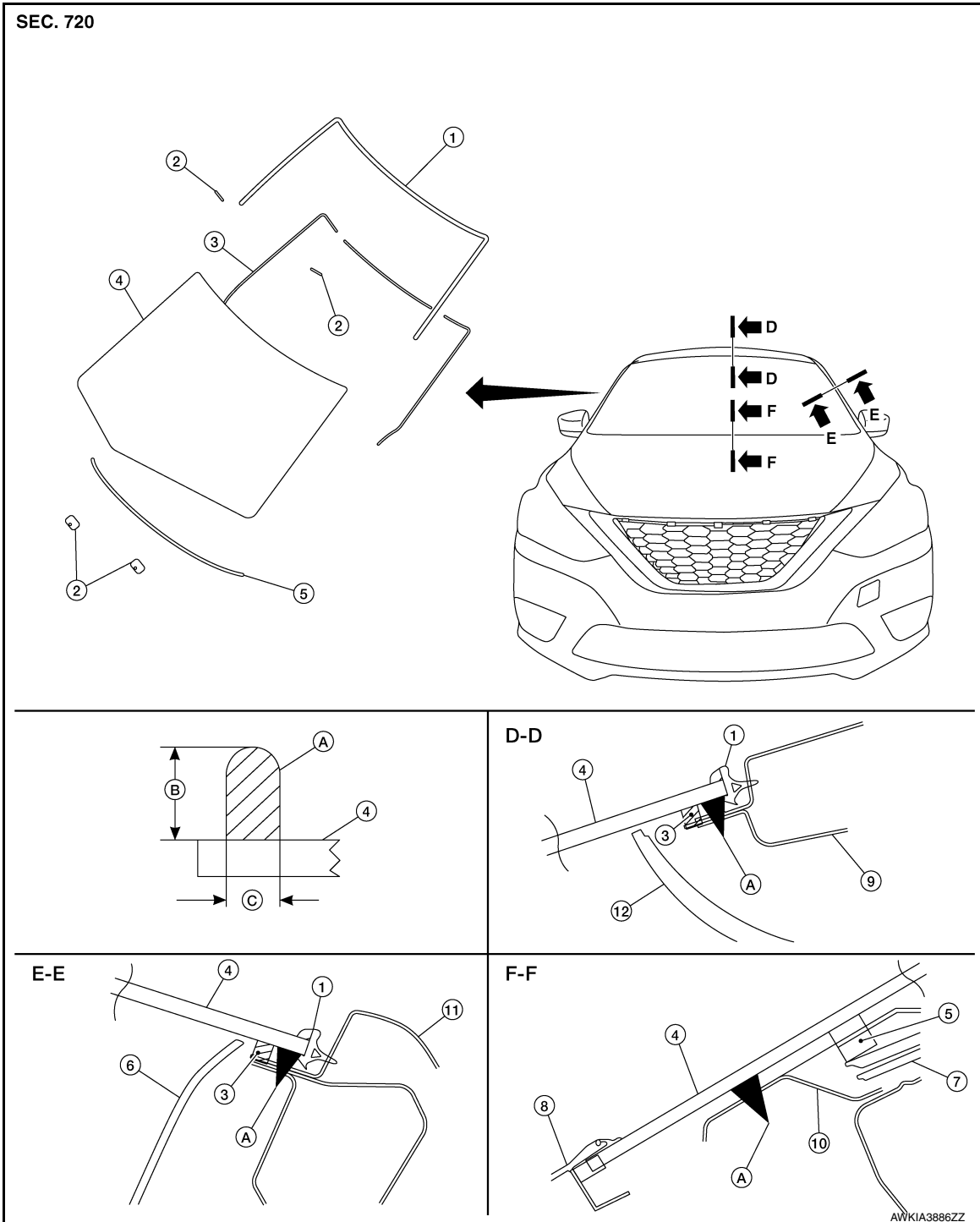

- |                             |                              |                             |
|-----------------------------|------------------------------|-----------------------------|
| 1. Windshield glass molding | 2. Spacer                    | 3. Rubber dam               |
| 4. Windshield glass         | 5. Windshield insulator      | 6. Front pillar finisher    |
| 7. Instrument panel         | 8. Cowl top cover            | 9. Roof panel               |
| 10. Cowl top                | 11. Body side outer          | 12. Headlining              |
| A. Adhesive                 | B. 12 +2.0 mm (0.5 +0.08 in) | C. 7 +2.0 mm (0.3 +0.08 in) |

A  
B  
C  
D  
E  
F  
G  
H  
I  
J  
L  
M  
N  
O  
P

GW

AWKIA3886ZZ

# WINDSHIELD GLASS

< REMOVAL AND INSTALLATION >

## Removal and Installation

INFOID:000000012783576

### REMOVAL

1. Partially remove the headlining (front edge). Refer to [INT-40, "Removal and Installation"](#).
2. Remove inside mirror. Refer to [MIR-17, "Removal and Installation"](#).
3. Remove the cowl top cover. Refer to [EXT-26, "Removal and Installation"](#).
4. Remove windshield glass using piano wire or power cutting tool (A) and an inflatable pump bag (B).

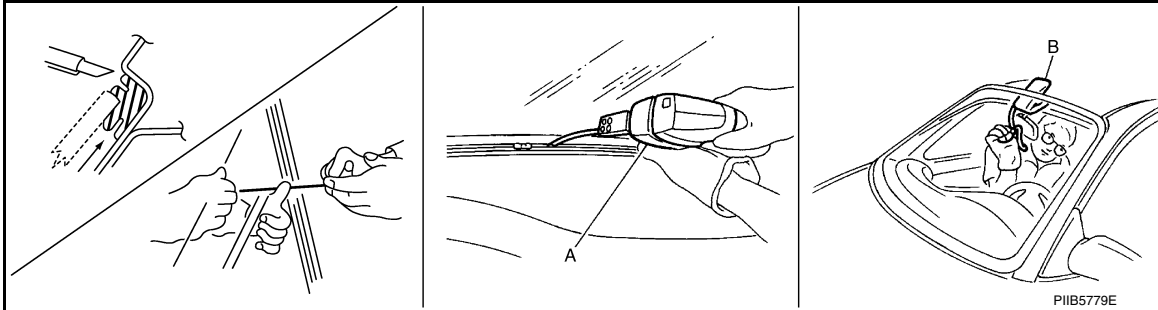

- Apply protective tape around the windshield glass to protect the painted surface from damage.
- If the windshield glass is to be reused, mark the body and the glass with matching marks.
- Minimum adhesive coating amount 8 +3,-0 g/100 mm (0.28 +0.11,-0 oz/3.9 in) all around.

#### **WARNING:**

**When cutting the glass from the vehicle, always wear safety glasses and heavy gloves to help prevent glass splinters from entering your eyes or cutting your hands.**

#### **CAUTION:**

- Be careful not to scratch the glass when removing.
- Do not set or stand the glass on its edge. Small chips may develop into cracks.
- Apply protective tape around the windshield glass to protect the painted surface from damage.

### INSTALLATION

Installation is in the reverse order of removal.

- If repainting near the windshield flange area, protect the flange adhesion area by masking the flange.
- Use a Genuine NISSAN Urethane Adhesive Kit (if available) or equivalent and follow the instructions furnished with it.
- Adhesive shall be continuously applied to assure watertightness. Glass installation shall be finished within five minutes after applying the adhesive.
- The start and finish of the urethane adhesive application should be located at the bottom to assure watertightness.
- While the urethane adhesive is curing, open a door window. This will prevent the glass from being forced out by passenger compartment air pressure when a door is closed.
- The molding must be installed securely to the windshield glass to avoid looseness and will leave no gap.
- Inform the customer that the vehicle should remain stationary until the urethane adhesive has completely cured (preferably 24 hours). Curing time varies with temperature and humidity.

#### **WARNING:**

- Keep heat and open flames away as primers and adhesive are flammable.
- The materials contained in the kit are harmful if swallowed, and may irritate skin and eyes. Avoid contact with the skin and eyes.
- Use in an open, well ventilated location. Avoid breathing the vapors. They can be harmful if inhaled. If affected by vapor inhalation, immediately move to an area with fresh air.
- Driving the vehicle before the urethane adhesive has completely cured may affect the performance of the windshield in case of an accident.

#### **CAUTION:**

- Do not use an adhesive which is past its usable term. Shelf life of this product is limited to six months after the date of manufacture. Carefully adhere to the expiration or manufacture date printed on the box or product.
- Keep primers and adhesive in a cool, dry place. Ideally, they should be stored in a refrigerator.
- Do not leave primers or adhesive cartridge unattended with their caps open or off.
- The vehicle should not be driven for at least 24 hours or until the urethane adhesive has completely cured. Curing time varies depending on temperature and humidity. The curing time will increase under lower temperature and lower humidity.

# WINDSHIELD GLASS

## < REMOVAL AND INSTALLATION >

### Primer Application

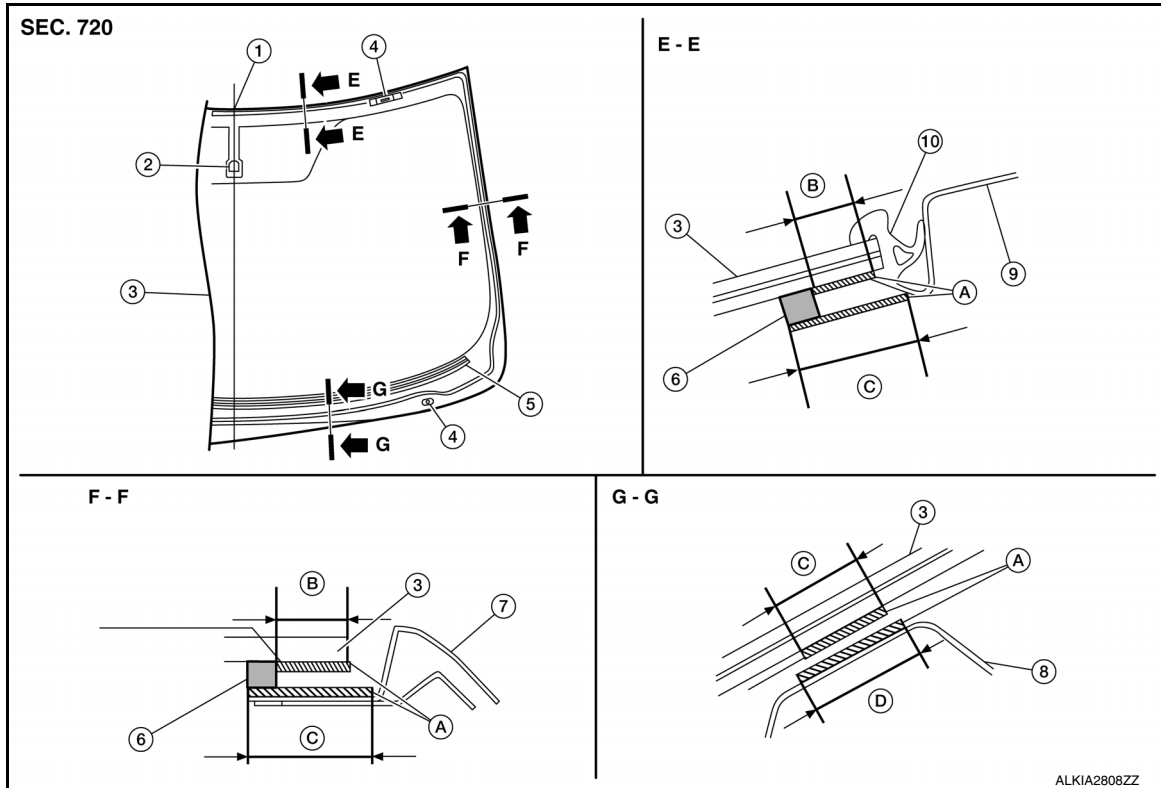

- |                                    |                         |                     |
|------------------------------------|-------------------------|---------------------|
| 1. Vehicle center                  | 2. Inside mirror base   | 3. Windshield glass |
| 4. Spacer                          | 5. Windshield insulator | 6. Rubber dam       |
| 7. Front pillar outer panel        | 8. Cowl top             | 9. Roof panel       |
| 10. Windshield glass upper molding | A. Primer portion       | B. 8.0 mm (0.31 in) |
| C. 20 mm (0.8 in)                  | D. 30 mm (1.2 in)       |                     |

### REPAIRING WATER LEAKS FOR WINDSHIELD

- Leaks can be repaired without removing and reinstalling glass.
- If water is leaking between the urethane adhesive material and body or glass, determine the extent of leakage.
- This can be done by applying water to the windshield area while pushing glass outward.
- To stop the leak, apply primer (if necessary) and then urethane adhesive to the leak point.

# FRONT DOOR GLASS

< REMOVAL AND INSTALLATION >

## FRONT DOOR GLASS

### Removal and Installation

INFOID:000000012783577

#### REMOVAL

##### **WARNING:**

- Before servicing, turn ignition switch OFF, disconnect both battery terminals and wait at least three minutes.
- Do not use air tools or electric tools for servicing.

##### **NOTE:**

LH front door panel shown; RH side similar

1. Disconnect the battery positive and negative terminal. Refer to [PG-74, "Removal and Installation \(Battery\)"](#).
2. Remove the front door finisher. Refer to [INT-15, "Removal and Installation"](#).
3. Remove the vapor barrier.

##### **CAUTION:**

**Use care to not damage or tear vapor barrier during removal.**

4. Temporarily reconnect both battery terminals and the main power window and door lock/unlock switch (LH door) or power window and door lock/unlock switch (RH door) to raise/lower the door glass until the door glass bolts can be seen through the access holes.
5. Remove the front door regulator to glass bolts (A).

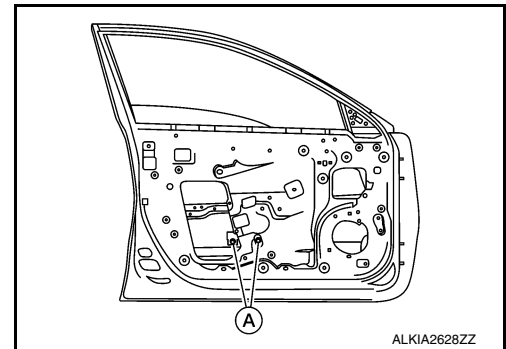

6. While holding the front door glass, raise it at the rear end to pull the front door glass out of the sash toward the outside of the door.

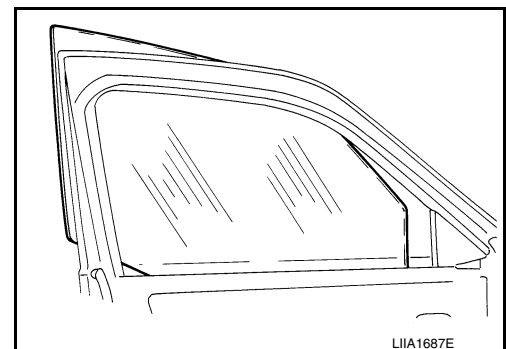

#### INSTALLATION

Installation is in the reverse order of removal.

#### FRONT DOOR GLASS INSPECTION AFTER INSTALLATION

- Check that the door glass is securely set into the glass run groove.
- Lower the door glass slightly [approximately 10 to 20 mm (0.4 to 0.8 in)] and check that the clearance to the sash is parallel. If the clearance between the door glass and sash is not parallel, loosen the regulator bolts, guide rail bolts, and door glass and guide rail bolts to correct the glass position.

#### Inspection and Adjustment

INFOID:000000012783578

#### SYSTEM INITIALIZATION (IF NECESSARY)

- If any of the following occur, system initialization must be performed.

## FRONT DOOR GLASS

### < REMOVAL AND INSTALLATION >

---

- Electric power supply to power window switch or motor is interrupted by blown fuse or disconnecting battery cable, etc. A
- Removal and installation of the regulator assembly.
- Removal and installation of the motor from the regulator assembly.
- Removal and installation of the harness connector of the power window switch. B
- Operation of the regulator assembly as a unit.
- Removal and installation of the door glass.
- Removal and installation of the door glass run.
- Window is partly opened and or closed multiple times with out being fully closed. C
- To perform system initialization, refer to [PWC-29, "Work Procedure"](#).

### INSPECT THE FUNCTION OF THE ANTI-PINCH SYSTEM.

To inspect the anti-pinch system, refer to [PWC-29, "Work Procedure"](#). D

E

F

G

H

I

J

GW

L

M

N

O

P

# FRONT REGULATOR

< REMOVAL AND INSTALLATION >

## FRONT REGULATOR

Exploded View

INFOID:000000012783579

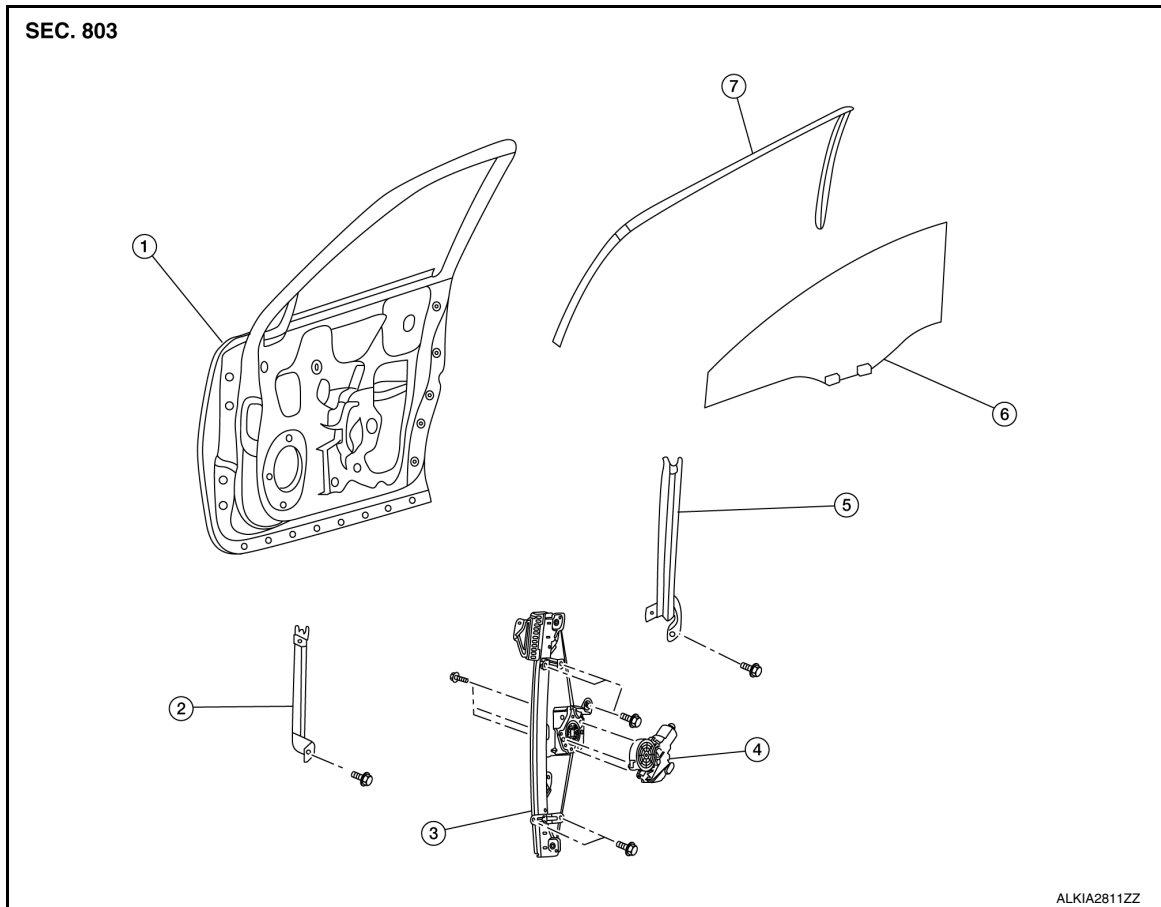

- |                                     |                                   |                               |
|-------------------------------------|-----------------------------------|-------------------------------|
| 1. Front door panel                 | 2. Front door glass channel front | 3. Front door glass regulator |
| 4. Front door glass regulator motor | 5. Front door glass channel rear  | 6. Front door glass           |
| 7. Front door glass rubber run      |                                   |                               |

## Removal and Installation

INFOID:000000012783580

### REMOVAL

#### **WARNING:**

- Before servicing, turn ignition switch OFF, disconnect both battery terminals and wait at least three minutes.
- Do not use air tools or electric tools for servicing.

#### **NOTE:**

LH front door panel shown; RH side similar.

1. Disconnect the battery positive and negative terminal. Refer to [PG-74, "Exploded View"](#).
2. Remove the front door finisher. Refer to [INT-15, "Removal and Installation"](#).
3. Remove the vapor barrier.

#### **CAUTION:**

**Use care to not damage or tear vapor barrier during removal.**

4. Temporarily reconnect both battery terminals and the main power window and door lock/unlock switch (LH door) or power window and door lock/unlock switch (RH door) to raise/lower the door glass until the door glass bolts can be seen through the access holes.



# FRONT REGULATOR

## < REMOVAL AND INSTALLATION >

5. Remove the front door regulator to glass bolts (A).

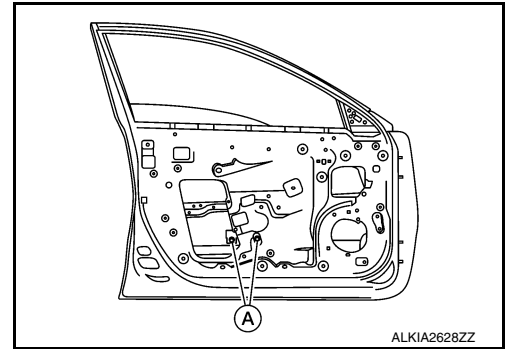

6. Raise the front door glass and hold with a suction lifter (A).

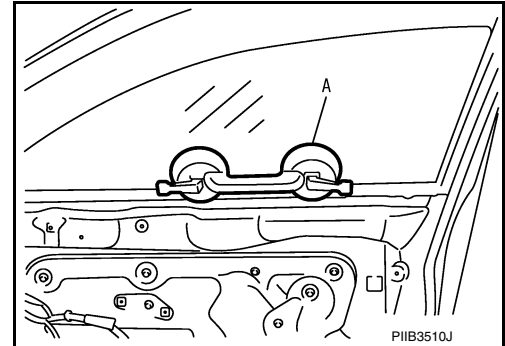

7. Disconnect the harness connector from the front door glass regulator motor.
8. Remove front door glass regulator bolts (A) and the front door glass regulator.

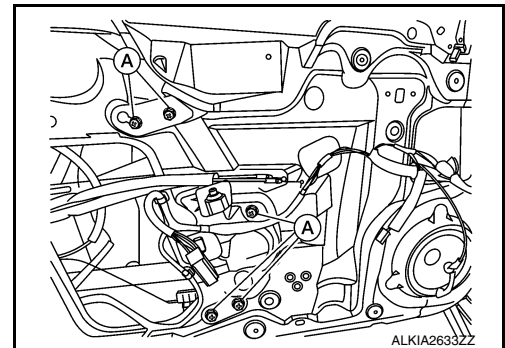

## INSPECTION AFTER REMOVAL

Check the front door glass regulator for the following items. If a malfunction is detected, replace the regulator.

- Excessive cable wear (B).
- Regulator channel deformation (A).
- Apply multi-purpose grease at the application points (➡) as shown.

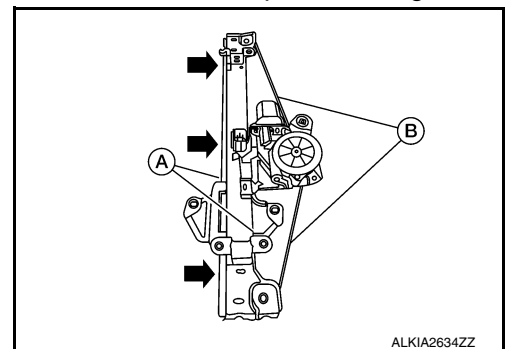

## INSTALLATION

Installation is in the reverse order of removal.

## Inspection and Adjustment

INFOID:000000012783581

## SYSTEM INITIALIZATION (IF NECESSARY)

- If any of the following occur, system initialization must be performed.

## FRONT REGULATOR

### < REMOVAL AND INSTALLATION >

---

- Electric power supply to power window switch or motor is interrupted by blown fuse or disconnecting battery cable, etc.
- Removal and installation of the regulator assembly.
- Removal and installation of the motor from the regulator assembly.
- Removal and installation of the harness connector of the power window switch.
- Operation of the regulator assembly as a unit.
- Removal and installation of the door glass.
- Removal and installation of the door glass run.
- Window is partly opened and or closed multiple times with out being fully closed.
- To perform system initialization, refer to [PWC-29, "Work Procedure"](#).

### INSPECT THE FUNCTION OF THE ANTI-PINCH SYSTEM.

To inspect the anti-pinch system, refer to [PWC-29, "Work Procedure"](#).

# FRONT POWER WINDOW MOTOR

< REMOVAL AND INSTALLATION >

## FRONT POWER WINDOW MOTOR

### Removal and Installation

INFOID:000000012783582

#### REMOVAL

1. Remove the front door glass regulator (2). Refer to [GW-16. "Removal and Installation"](#).
2. Remove the bolts (A) and the front power window motor (1).

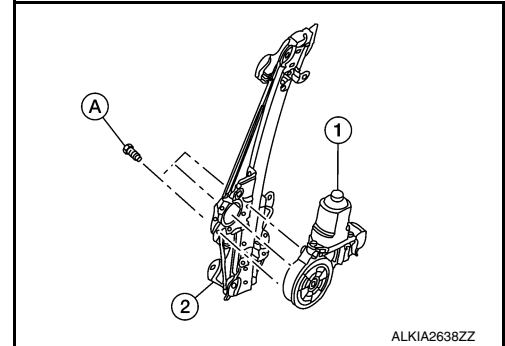

#### INSTALLATION

Installation is in the reverse order of removal.

A  
B  
C  
D  
E  
F  
G  
H  
I  
J  
GW  
L  
M  
N  
O  
P

# REAR DOOR GLASS

< REMOVAL AND INSTALLATION >

## REAR DOOR GLASS

### Removal and Installation

INFOID:000000012783583

#### REMOVAL

##### NOTE:

LH rear door panel shown; RH similar.

1. Remove the rear door finisher. Refer to [INT-19. "Removal and Installation"](#).
2. Remove the vapor barrier.  
**CAUTION:**  
**Use care to not damage or tear vapor barrier during removal.**
3. Remove the rear door window run rubber.
4. Remove bolts (A) and rear door glass rear run channel (1).

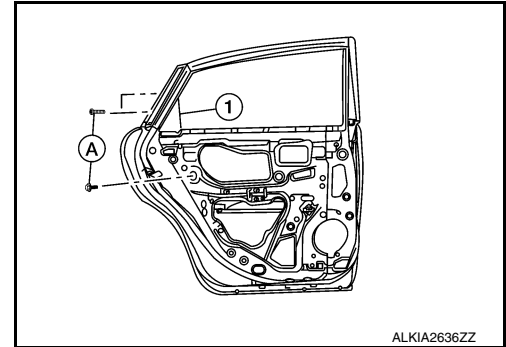

5. Temporarily reconnect the rear power window switch to raise/lower the rear door glass until the rear door regulator to glass bolts (A) can be seen through the access holes.
6. Remove the rear door glass to regulator bolts (A).

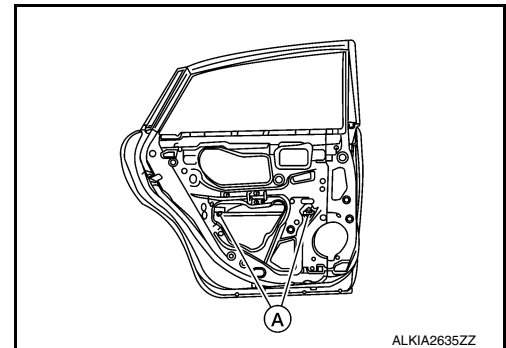

7. Remove the rear door glass.

#### INSTALLATION

Installation is in the reverse order of removal.

- After installation inspect and adjust as necessary.

#### REAR DOOR GLASS INSPECTION AFTER INSTALLATION

- Check that the door glass is securely set into the glass run groove.
- Lower the glass slightly [approx. 10 to 20 mm (0.4 to 0.8 in)], and make sure the clearance to the sash is parallel. If the clearance between the glass and sash is not parallel, loosen the regulator mounting bolts, guide rail mounting bolts, and glass and carrier plate mounting bolts to correct the glass position.

# REAR REGULATOR

< REMOVAL AND INSTALLATION >

## REAR REGULATOR

Exploded View

INFOID:000000012783584

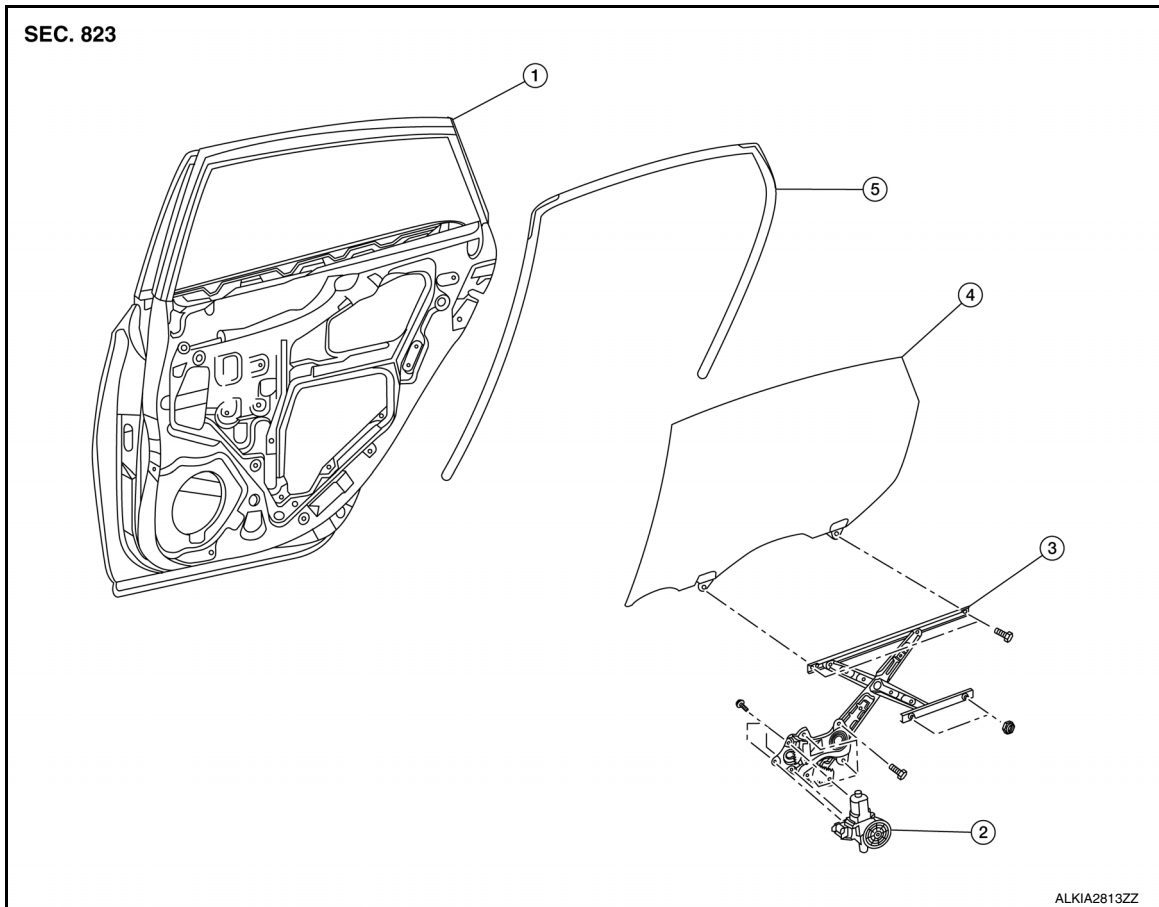

- |                    |                                    |                              |
|--------------------|------------------------------------|------------------------------|
| 1. Rear door panel | 2. Rear door glass regulator motor | 3. Rear door glass regulator |
| 4. Rear door glass | 5. Rear door glass rubber run      |                              |

### Removal and Installation

INFOID:000000012783585

#### NOTE:

RH rear door panel shown; LH side similar

#### REMOVAL

1. Remove the rear door finisher. Refer to [INT-19. "Removal and Installation"](#).
2. Remove the vapor barrier.

#### CAUTION:

**Use care to not damage or tear vapor barrier during removal.**

3. Partially remove the rear door window run rubber.

A  
B  
C  
D  
E  
F  
G  
H  
I  
J

GW

L  
M  
N  
O  
P

## REAR REGULATOR

### < REMOVAL AND INSTALLATION >

4. Remove bolts (A) and the rear door glass rear run channel (1).

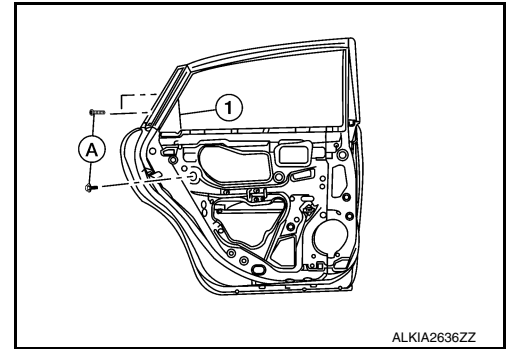

5. Temporarily reconnect the rear power window switch to raise/lower the rear door glass until the rear door regulator to glass bolts (A) can be seen through the access holes.
6. Remove the rear door regulator to glass bolts (A).

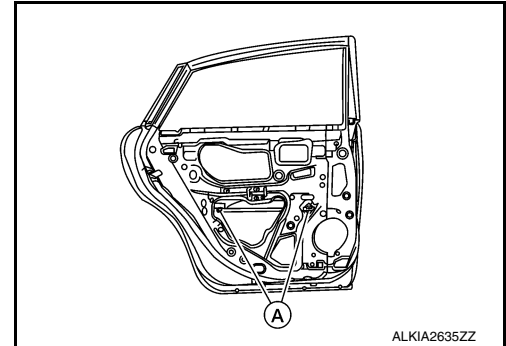

7. Raise up the rear door glass and hold with a suction lifter (A).

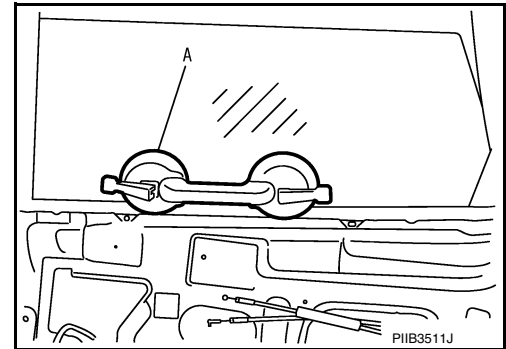

8. Disconnect the harness connector from the rear door glass regulator.
9. Remove nuts/bolts (➡) and the rear door glass regulator (1).

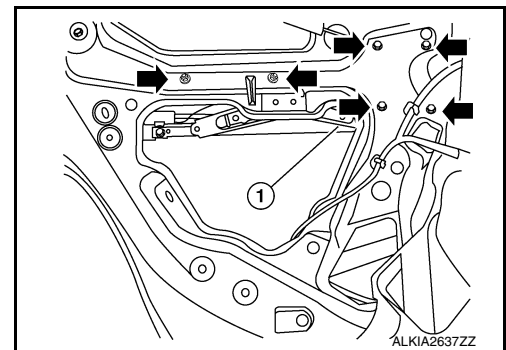

### INSPECTION AFTER REMOVAL

Check the rear door glass regulator for the following items. If a malfunction is detected, replace or grease it.

- Gear wear
- Regulator deformation
- Grease condition for each sliding part
- Apply multi-purpose grease at sliding points.

### INSTALLATION

Installation is in the reverse order of removal.

# REAR POWER WINDOW MOTOR

< REMOVAL AND INSTALLATION >

## REAR POWER WINDOW MOTOR

### Removal and Installation

INFOID:000000012783586

#### REMOVAL

1. Remove the rear door glass regulator (1). Refer to [GW-21. "Removal and Installation"](#)
2. Remove the screws and the rear power window motor (2).

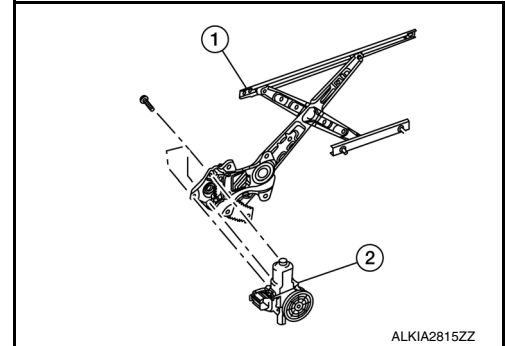

#### INSTALLATION

Installation is in the reverse order of removal.

A  
B  
C  
D  
E  
F  
G  
H  
I  
J  
L  
M  
N  
O  
P

GW

# SIDE WINDOW GLASS

< REMOVAL AND INSTALLATION >

## SIDE WINDOW GLASS

### Components

INFOID:000000012783587

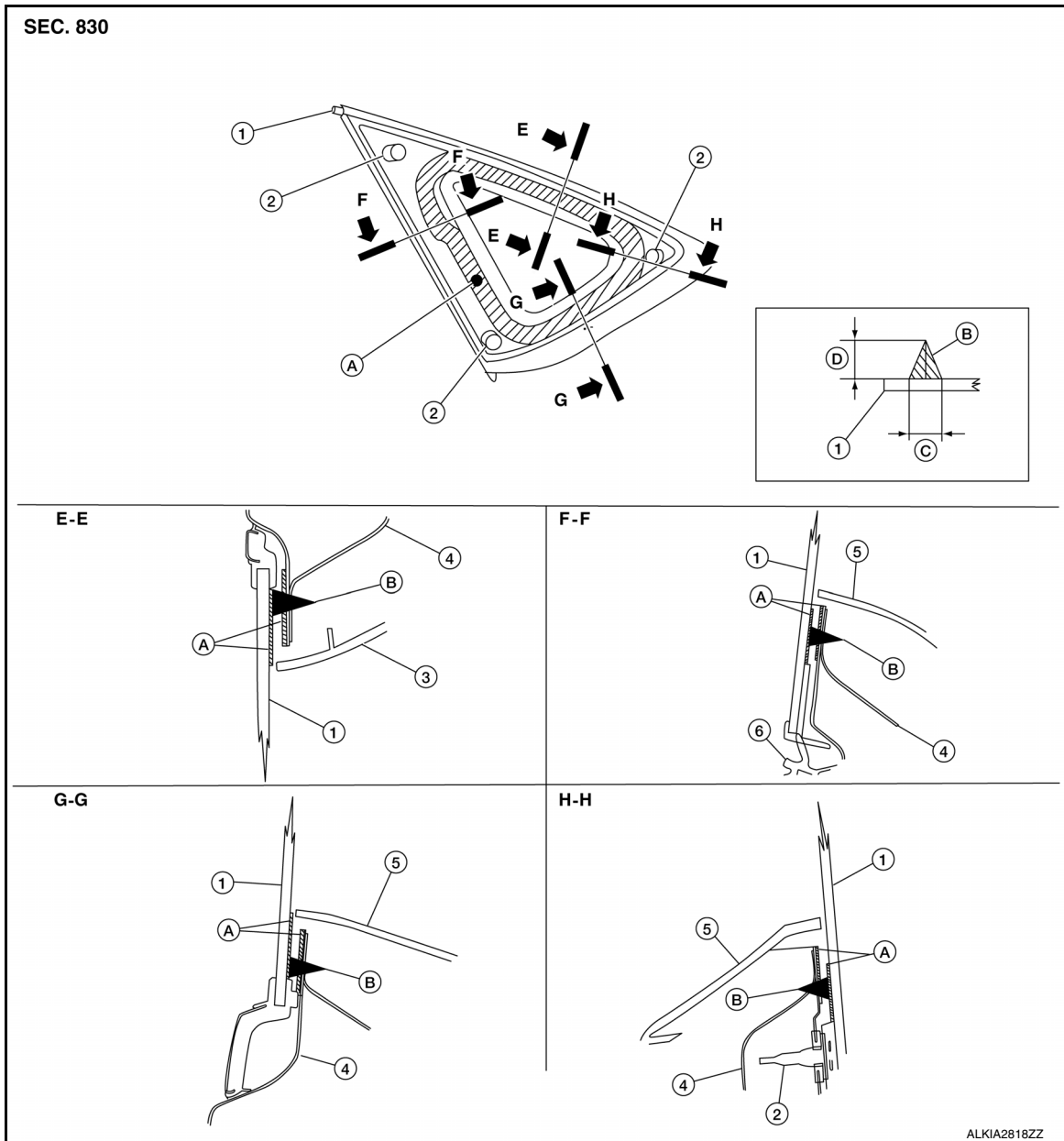

- |                      |                         |                           |
|----------------------|-------------------------|---------------------------|
| 1. Side window glass | 2. Spacer               | 3. Headlining             |
| 4. Rear body pillar  | 5. Rear pillar finisher | 6. Rear door weatherstrip |
| A. Primer area       | B. Adhesive             | C. 7 mm (0.3 in)          |
| D. 12 mm (0.5 in)    |                         |                           |

### Removal and Installation

INFOID:000000012783588

#### REMOVAL

1. Remove the rear pillar finisher. Refer to [INT-29, "REAR PILLAR FINISHER : Removal and Installation"](#).



## SIDE WINDOW GLASS

### < REMOVAL AND INSTALLATION >

- After removing moldings, remove the glass using piano wire or power cutting tool (A) and an inflatable pump (B).

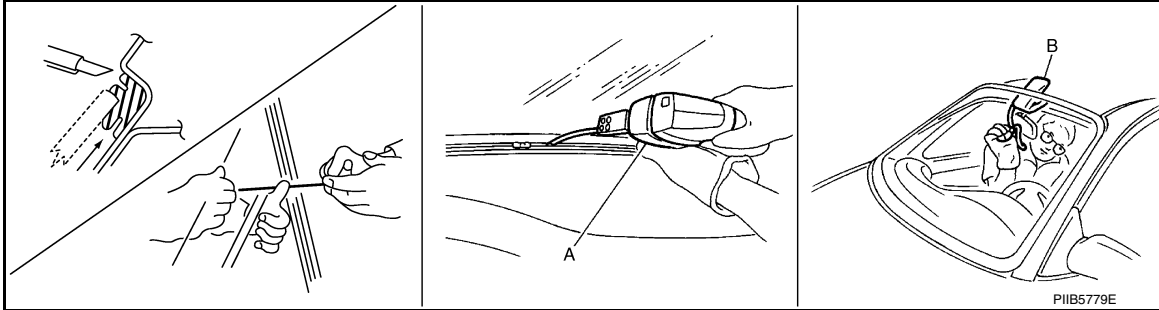

- Apply protective tape around the windshield glass to protect the painted surface from damage.
- If the windshield glass is to be reused, mark the body and the glass with matching marks.
- Minimum adhesive coating amount 8 +3,-0 g/100 mm (0.28 +0.11,-0 oz/3.9 in) all around.
- Minimum primer application area 20.0 mm (0.79 in) on body and glass side.

#### **WARNING:**

When cutting the glass from the vehicle, always wear safety glasses and heavy gloves to help prevent glass splinters from entering your eyes or cutting your hands.

#### **CAUTION:**

- Be careful not to scratch the glass when removing.
- Do not set or stand the glass on its edge. Small chips may develop into cracks.
- Apply protective tape around the windshield glass to protect the painted surface from damage.

### INSTALLATION

Installation is in the reverse order of removal.

- If repainting near the rear window glass flange area, protect the flange adhesion area by masking the flange.
- Use a Genuine NISSAN Urethane Adhesive Kit (if available) or equivalent and follow the instructions furnished with it.
- Adhesive shall be continuously applied to assure watertightness. Glass installation shall be finished within five minutes after applying the adhesive.
- The start and finish of the urethane adhesive application should be located at the bottom to assure watertightness.
- While the urethane adhesive is curing, open a door window. This will prevent the glass from being forced out by passenger compartment air pressure when a door is closed.
- Inform the customer that the vehicle should remain stationary until the urethane adhesive has completely cured (preferably 24 hours). Curing time varies with temperature and humidity.

#### **WARNING:**

- Keep heat and open flames away as primers and adhesive are flammable.
- The materials contained in the kit are harmful if swallowed, and may irritate skin and eyes. Avoid contact with the skin and eyes.
- Use in an open, well ventilated location. Avoid breathing the vapors. They can be harmful if inhaled. If affected by vapor inhalation, immediately move to an area with fresh air.
- Driving the vehicle before the urethane adhesive has completely cured may affect the performance of the side window glass in case of an accident.

#### **CAUTION:**

- Do not use an adhesive which is past its usable term. Shelf life of this product is limited to six months after the date of manufacture. Carefully adhere to the expiration or manufacture date printed on the box or product.
- Keep primers and adhesive in a cool, dry place. Ideally, they should be stored in a refrigerator.
- Do not leave primers or adhesive cartridge unattended with their caps open or off.
- The vehicle should not be driven for at least 24 hours or until the urethane adhesive has completely cured. Curing time varies depending on temperature and humidity. The curing time will increase under lower temperature and lower humidity.

### REPAIRING WATER LEAKS FOR SIDE WINDOW GLASS

- Leaks can be repaired without removing and reinstalling glass.
- If water is leaking between the urethane adhesive material and body or glass, determine the extent of leakage.
- This can be done by applying water to the side window area while pushing glass outward.
- To stop the leak, apply primer (if necessary) and then urethane adhesive to the leak point.

# REAR WINDOW GLASS

< REMOVAL AND INSTALLATION >

## REAR WINDOW GLASS

Exploded View

INFOID:000000012783589

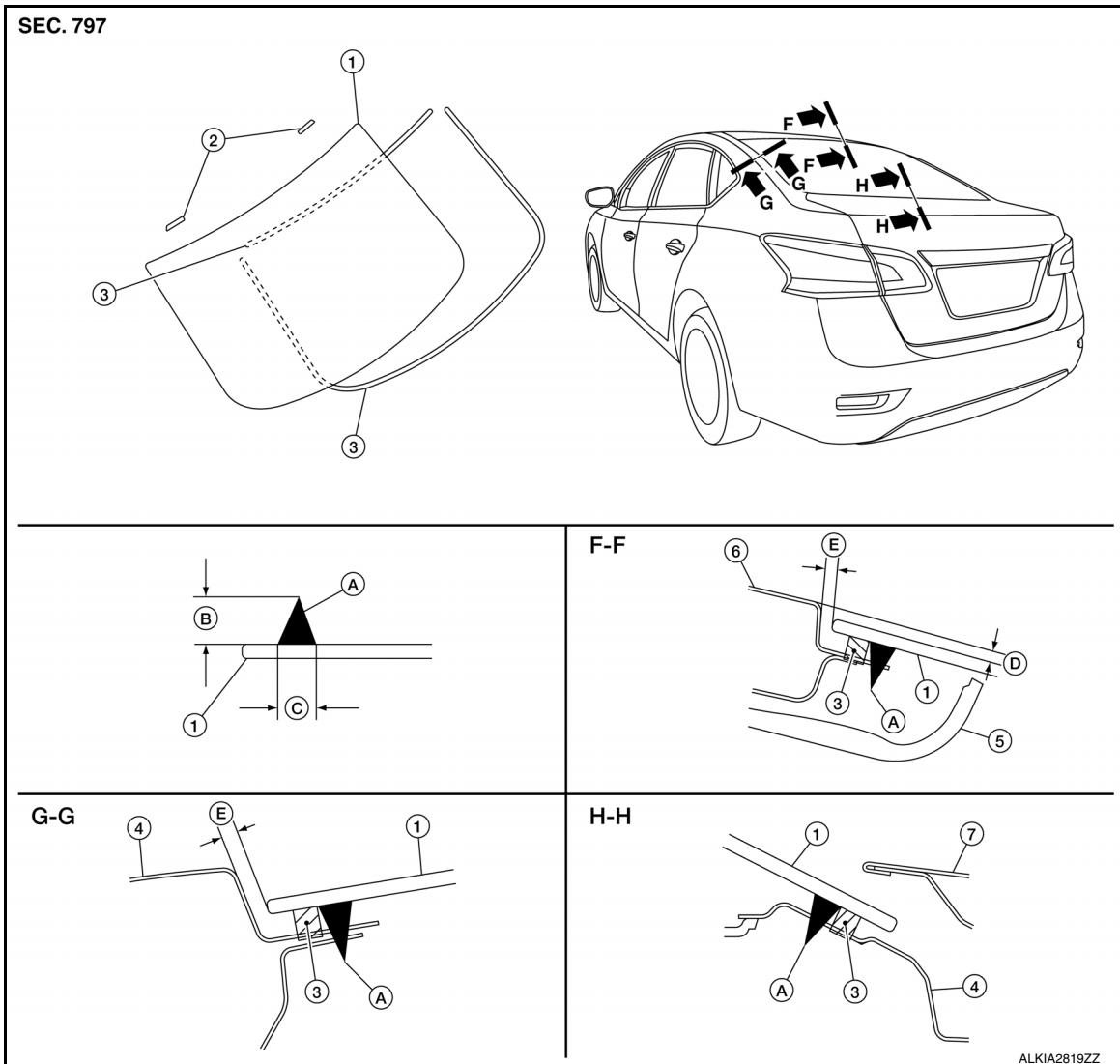

- |                      |                     |                   |
|----------------------|---------------------|-------------------|
| 1. Rear window glass | 2. Spacer           | 3. Rubber dam     |
| 4. Body side outer   | 5. Headlining       | 6. Roof panel     |
| 7. Trunk lid         | A. Adhesive         | B. 12 mm (0.5 in) |
| C. 7 mm (0.3 in)     | D. 2.0 mm (0.08 in) | E. 3 mm (0.1 in)  |

## Removal and Installation

INFOID:000000012783590

### REMOVAL

- Partially remove the rear of the headlining (rear edge). Refer to [INT-40. "Removal and Installation"](#).
- Remove the rear pillar finishers (LH/RH). Refer to [INT-29. "REAR PILLAR FINISHER : Removal and Installation"](#).
- Remove the connectors and grounds for the rear window defogger and printed antenna.

## REAR WINDOW GLASS

### < REMOVAL AND INSTALLATION >

4. Remove windshield glass using piano wire or power cutting tool (A) and an inflatable pump bag (B).

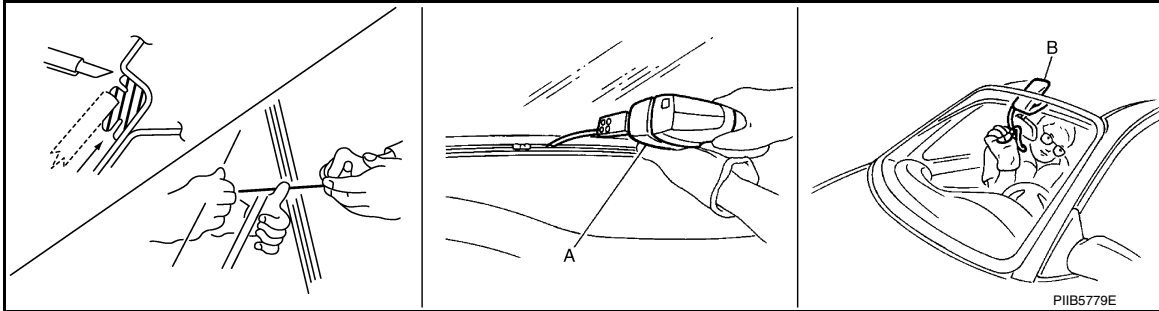

- Apply protective tape around the rear window glass to protect the painted surface from damage.
- If the rear window glass is to be reused, mark the body and the glass with matching marks.
- Minimum adhesive coating amount 8 +3,-0 g/100 mm (0.28 +0.11,-0 oz/3.9 in) all around.
- Minimum primer application area 15 ±1 mm (0.6 ±0.04 in) on body side and 13.0 mm (0.51 in) on glass side.

#### **WARNING:**

When cutting the glass from the vehicle, always wear safety glasses and heavy gloves to help prevent glass splinters from entering your eyes or cutting your hands.

#### **CAUTION:**

- Be careful not to scratch the glass when removing.
- Do not set or stand the glass on its edge. Small chips may develop into cracks.
- Apply protective tape around the rear window glass to protect the painted surface from damage.

### INSTALLATION

Installation is in the reverse order of removal.

- If repainting near the rear window flange area, protect the flange adhesion area by masking the flange.
- Use a Genuine NISSAN Urethane Adhesive Kit (if available) or equivalent and follow the instructions furnished with it.
- Adhesive shall be continuously applied to ensure watertightness. Glass installation shall be finished within five minutes after applying the adhesive.
- The start and finish of the urethane adhesive application should be located at the bottom to assure watertightness.
- While the urethane adhesive is curing, open a door window. This will prevent the glass from being forced out by passenger compartment air pressure when a door is closed.
- The molding must be installed securely to the rear window glass to avoid looseness and will leave no gap.
- Inform the customer that the vehicle should remain stationary until the urethane adhesive has completely cured (preferably 24 hours). Curing time varies with temperature and humidity.

#### **WARNING:**

- Keep heat and open flames away as primers and adhesive are flammable.
- The materials contained in the kit are harmful if swallowed, and may irritate skin and eyes. Avoid contact with the skin and eyes.
- Use in an open, well ventilated location. Avoid breathing the vapors. They can be harmful if inhaled. If affected by vapor inhalation, immediately move to an area with fresh air.
- Driving the vehicle before the urethane adhesive has completely cured may affect the performance of the rear window in case of an accident.

#### **CAUTION:**

- Do not use an adhesive which is past its usable term. Shelf life of this product is limited to six months after the date of manufacture. Carefully adhere to the expiration or manufacture date printed on the box or product.
- Keep primers and adhesive in a cool, dry place. Ideally, they should be stored in a refrigerator.
- Do not leave primers or adhesive cartridge unattended with their caps open or off.
- The vehicle should not be driven for at least 24 hours or until the urethane adhesive has completely cured. Curing time varies depending on temperature and humidity. The curing time will increase under lower temperature and lower humidity.

### REPAIRING WATER LEAKS FOR REAR WINDOW GLASS

- Leaks can be repaired without removing and reinstalling glass.
- If water is leaking between the urethane adhesive material and body or glass, determine the extent of leakage.
- This can be done by applying water to the side window area while pushing glass outward.

## REAR WINDOW GLASS

### < REMOVAL AND INSTALLATION >

---

- To stop the leak, apply primer (if necessary) and then urethane adhesive to the leak point.