

A
B
C
D
E

SECTION **PB**

PARKING BRAKE SYSTEM

CONTENTS

<p>PRECAUTION 2</p> <p>PRECAUTIONS 2</p> <p style="padding-left: 20px;">Precaution for Supplemental Restraint System (SRS) "AIR BAG" and "SEAT BELT PRE-TENSIONER"2</p> <p>PREPARATION 3</p> <p>PREPARATION 3</p> <p style="padding-left: 20px;">Commercial Service Tool3</p> <p>BASIC INSPECTION 4</p> <p>PARKING BRAKE SYSTEM 4</p> <p style="padding-left: 20px;">Inspection and Adjustment4</p> <p>PARKING BRAKE SHOE 6</p> <p style="padding-left: 20px;">Adjustment - Drum Brake6</p> <p style="padding-left: 20px;">Adjustment - Disc Brake6</p>	<p>REMOVAL AND INSTALLATION 7</p> <p>PARKING BRAKE CONTROL 7</p> <p style="padding-left: 20px;">Exploded View 7</p> <p style="padding-left: 20px;">Removal and Installation 7</p> <p style="padding-left: 20px;">Adjustment 8</p> <p>PARKING BRAKE SHOE 9</p> <p style="padding-left: 20px;">Removal and Installation - Drum Brake 9</p> <p style="padding-left: 20px;">Exploded View - Disc Brake 9</p> <p style="padding-left: 20px;">Removal and Installation - Disc Brake 9</p> <p style="padding-left: 20px;">Inspection and Adjustment11</p> <p>SERVICE DATA AND SPECIFICATIONS (SDS)13</p> <p>SERVICE DATA AND SPECIFICATIONS (SDS)13</p> <p style="padding-left: 20px;">Parking Drum Brake13</p> <p style="padding-left: 20px;">Parking Brake Control13</p>
--	--

PB
G
H
I
J
K
L
M
N
O
P

PRECAUTIONS

< PRECAUTION >

PRECAUTION

PRECAUTIONS

Precaution for Supplemental Restraint System (SRS) "AIR BAG" and "SEAT BELT PRE-TENSIONER"

INFOID:000000012787104

The Supplemental Restraint System such as "AIR BAG" and "SEAT BELT PRE-TENSIONER", used along with a front seat belt, helps to reduce the risk or severity of injury to the driver and front passenger for certain types of collision. Information necessary to service the system safely is included in the SR and SB section of this Service Manual.

WARNING:

- To avoid rendering the SRS inoperative, which could increase the risk of personal injury or death in the event of a collision which would result in air bag inflation, it is recommended that all maintenance and repair be performed by an authorized NISSAN/INFINITI dealer.
- Improper repair, including incorrect removal and installation of the SRS, can lead to personal injury caused by unintentional activation of the system. For removal of Spiral Cable and Air Bag Module, see the SR section.
- Do not use electrical test equipment on any circuit related to the SRS unless instructed to in this Service Manual. SRS wiring harnesses can be identified by yellow and/or orange harnesses or harness connectors.

PRECAUTIONS WHEN USING POWER TOOLS (AIR OR ELECTRIC) AND HAMMERS

WARNING:

- When working near the Air Bag Diagnosis Sensor Unit or other Air Bag System sensors with the Ignition ON or engine running, DO NOT use air or electric power tools or strike near the sensor(s) with a hammer. Heavy vibration could activate the sensor(s) and deploy the air bag(s), possibly causing serious injury.
- When using air or electric power tools or hammers, always switch the Ignition OFF, disconnect the battery or batteries, and wait at least three minutes before performing any service.

PREPARATION



< PREPARATION >

PREPARATION

PREPARATION

Commercial Service Tool

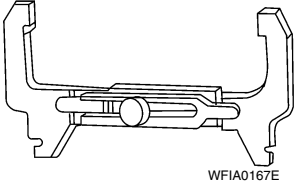
INFOID:0000000012787105

Tool name	Description
<p data-bbox="159 411 451 441">Brake drum clearance gauge</p>  <p data-bbox="865 632 938 646">WFIA0167E</p>	<p data-bbox="1060 411 1466 441">Measuring rear rotor drum inner diameter</p>
<p data-bbox="159 659 272 688">Power tool</p>  <p data-bbox="865 884 938 898">PIIB1407E</p>	<p data-bbox="1060 659 1401 688">Loosening nuts, screws and bolts</p>

A
B
C
D
E
PB
G
H
I
J
K
L
M
N
O
P

PARKING BRAKE SYSTEM

< BASIC INSPECTION >

BASIC INSPECTION

PARKING BRAKE SYSTEM

Inspection and Adjustment

INFOID:000000012787106

INSPECTION

Lever Stroke

1. Operate the parking brake lever with a force of 196 N (20.0 kg-f, 44.1 lb-f). Check that the lever stroke is within the specified number of notches. (Check it by listening to the clicks of the ratchet.)

Number of notches : Refer to [PB-13, "Parking Brake Control"](#).

2. When brake warning lamp turns ON, check that the lever stroke is within the specified number of notches. (Check it by listening to the clicks of the ratchet.)

Number of notches : Refer to [PB-13, "Parking Brake Control"](#).

Inspect Components

- Make sure that the attachment conditions (looseness, backlash, etc.) of each component are normal.
- Check the following:
 - Device assembly for bends, damage and cracks. Replace if any damage is noted.
 - Cables and equalizer for wear and damage. Replace if any damage is noted.
 - Parking brake switch. Replace if it does not work correctly.

ADJUSTMENT - Drum Brakes

1. Remove center console cup holder finisher. Refer to [IP-17, "Exploded View"](#).
2. Engage parking brake lever, then lift up the end of the trim on the parking brake lever to access the adjusting nut.
3. Insert a suitable tool onto adjusting nut (1). Rotate adjusting nut to fully loosen cable, and then release parking brake lever.

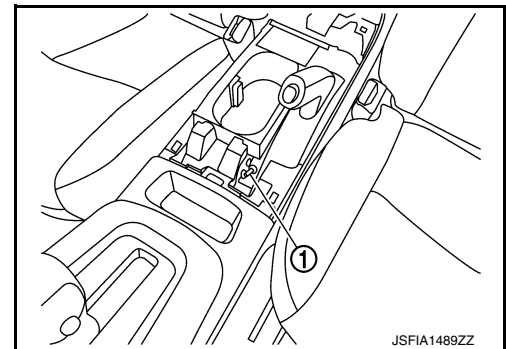

JSFIA1489ZZ

4. Depress the foot brake about 10 times and adjust the rear shoe clearance.
CAUTION:
Be sure to securely depress the foot brake.
5. Rotate brake drum to make sure that there is no drag.
6. Adjust parking brake cable with the following procedure.
 - a. When replace parking brake cable, operate parking brake lever with a force of 400 N (40.8 kg-f, 89.9 lb-f) about 10 times.
 - b. Engage parking brake lever, then lift up the end of the trim on the parking brake lever to access the adjusting nut.
 - c. Rotate adjusting nut to adjust parking brake lever stroke using suitable tool.
 - d. Operate parking brake lever with a force of 196 N (20.0 kg-f, 44.1 lb-f), make sure the parking brake lever stroke is within the specified number of notches. (Check it by listening and counting ratchet clicks.)

Number of notches Refer to [PB-13, "Parking Brake Control"](#).

- e. Make sure that there is no drag on rear brake with parking brake lever completely released.

PARKING BRAKE SYSTEM

< BASIC INSPECTION >

7. Install center console cup holder finisher. Refer to [IP-17, "Exploded View"](#).

ADJUSTMENT - Disc Brakes

1. Remove rear wheels and tires using power tool. Refer to [WT-47, "Adjustment"](#).
2. Secure both disc rotors to wheel hubs using wheel nuts.
3. Remove the adjusting hole plug from the disc rotor. Turn the adjuster (1) in the direction (A) as shown using suitable tool until the disc rotor is locked.
4. Turn back the adjuster 7 notches from the locked position.
5. Rotate the disc rotor to check that there is no drag. Install the adjuster hole plug. Refer to [PB-11, "Inspection and Adjustment"](#).

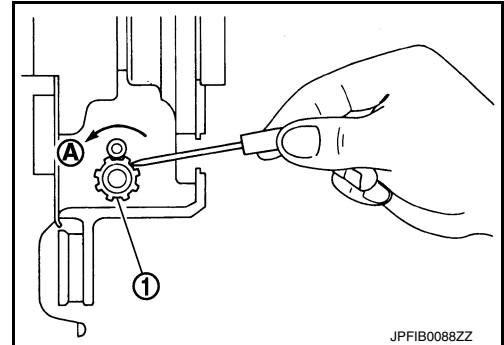

6. Adjust the cable with the following procedure.
 - a. Operate the parking brake lever with a force of 400 N (40.8 kg-f, 89.9 lb-f) for 10 strokes or more.
 - b. Remove center console cup holder finisher. Refer to [IP-17, "Exploded View"](#).
 - c. Insert suitable tool onto adjusting nut (1). Adjust the parking brake lever stroke by turning the adjusting nut (1).

CAUTION:

Make sure to securely depress the brake pedal.

- d. Operate the parking brake lever with a force of 196 N (20.0 kg-f, 44.1 lb-f). Check that the parking brake lever stroke is within the specified number of notches. (Check it by listening to the clicks of the ratchet.)

Number of notches : Refer to [PB-13, "Parking Brake Control"](#).

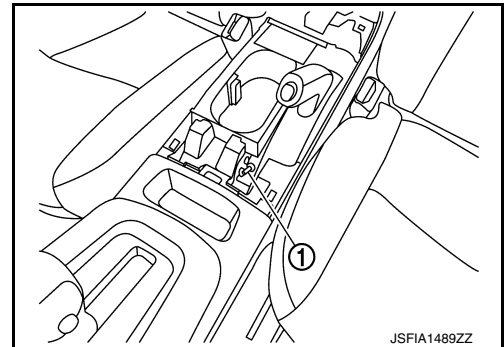

- e. Rotate the disc rotor to check that there is no drag. Refer to [PB-11, "Inspection and Adjustment"](#).
7. Install center console cup holder finisher. Refer to [IP-17, "Exploded View"](#).

PARKING BRAKE SHOE

< BASIC INSPECTION >

PARKING BRAKE SHOE

Adjustment - Drum Brake

INFOID:000000012787107

If equipped with drum brakes, refer to [PB-11, "Inspection and Adjustment"](#).

Adjustment - Disc Brake

INFOID:000000012787108

1. Adjust parking brake lever stroke. Refer to [PB-4, "Inspection and Adjustment"](#).
2. Perform parking brake break-in (drag on) operation by driving vehicle under the following conditions:
 - Drive forward
 - Vehicle speed: Approx. 43 km/h (27 MPH) set (constant and forward)
 - Parking brake operating force: 125 N (12.8 kg-f, 28.1 lb-f) set contact
 - Time: Approx. 8 sec.

CAUTION:

To prevent lining from getting too hot, allow a cool off period of approximately 5 minutes after every break-in operation.

3. After the break-in procedure, check parking brake lever stroke.

CAUTION:

If it is out of the specification, adjust again. Refer to [PB-4, "Inspection and Adjustment"](#).

PARKING BRAKE CONTROL

< REMOVAL AND INSTALLATION >

1. Pull equalizer (A) of the front parking brake cable (1) in a rearward direction and then push upward to remove each rear parking brake cable (2)

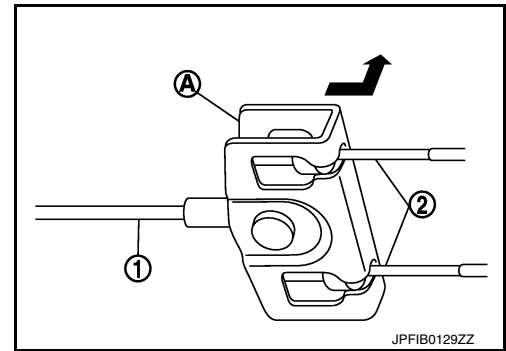

2. Remove sub muffler and heat plate. Refer to [EX-6, "Removal and Installation"](#).
3. Remove rear parking brake cable from toggle lever. Refer to [BR-42, "Exploded View"](#) (drum brake) or [PB-9, "Exploded View - Disc Brake"](#) (disc brake).
4. Remove rear parking brake cable bolts.
5. Press the pawl (1) to remove each rear parking brake cable from the vehicle.

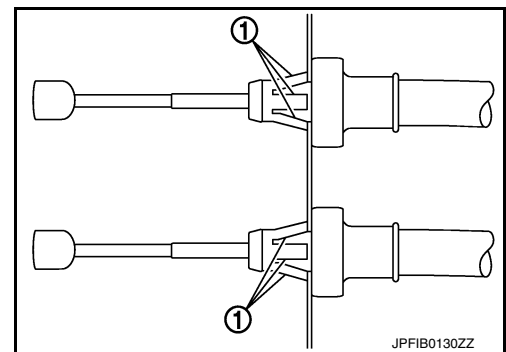

INSTALLATION

Installation is in the reverse order of removal.

CAUTION:

Do not reuse adjusting nut.

- Perform adjustment after installation. Refer to [PB-4, "Inspection and Adjustment"](#).

Adjustment

INFOID:000000012787111

ADJUSTMENT AFTER INSTALLATION

Adjust the parking brake lever stroke. Refer to [PB-4, "Inspection and Adjustment"](#).

PARKING BRAKE SHOE

< REMOVAL AND INSTALLATION >

PARKING BRAKE SHOE

Removal and Installation - Drum Brake

INFOID:0000000012787112

If equipped with drum brakes, refer to [BR-42. "Removal and Installation"](#).

Exploded View - Disc Brake

INFOID:0000000012787113

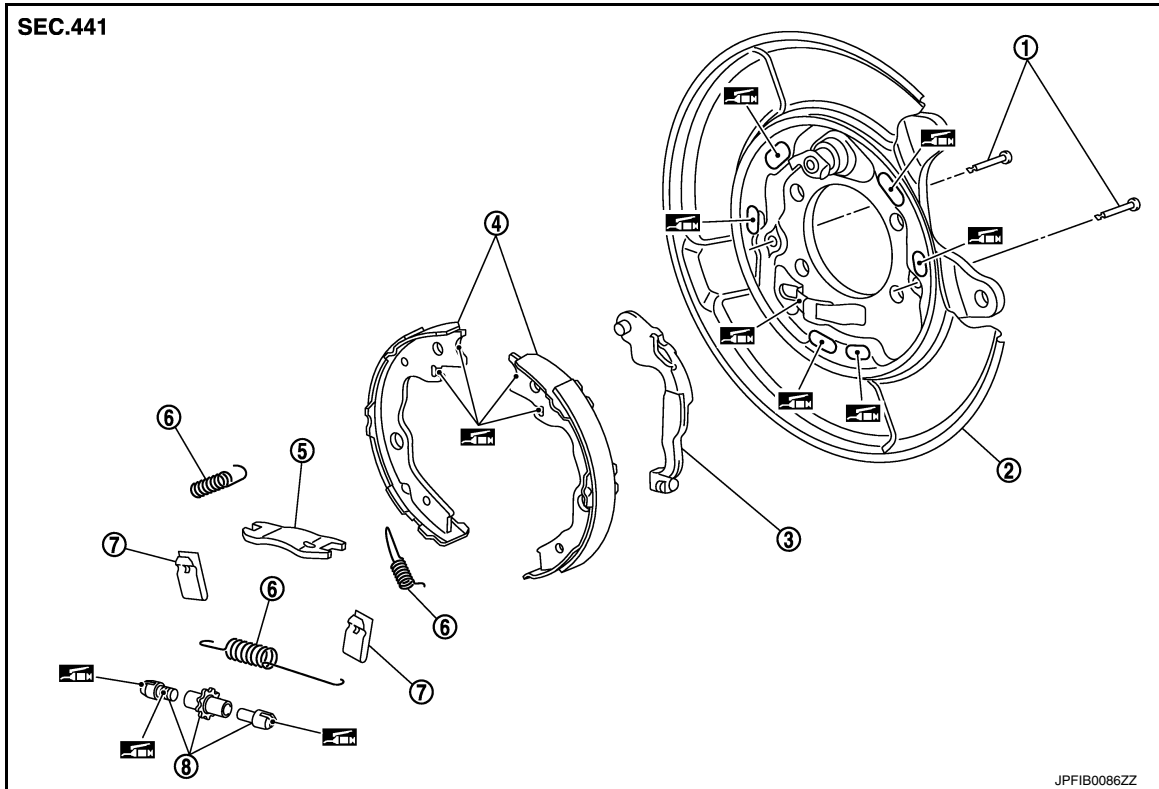

1. Anti-rattle pin
4. Parking brake shoe
7. Spring

2. Back plate
5. Brake strut
8. Adjuster

3. Toggle lever
6. Return spring

 Apply PBC (Poly Butyl Cuprysil) grease or silicone based grease

Removal and Installation - Disc Brake

INFOID:0000000012787114

REMOVAL

WARNING:

Clean dust on the parking brake shoes with a vacuum dust collector to minimize the hazard of air borne particles or other materials.

1. Remove rear wheels and tires using power tool. Refer to [WT-47. "Adjustment"](#).
2. Remove disc rotor. Refer to [RAX-7. "Removal and Installation - Disc brake"](#).

CAUTION:

Parking brake must be completely released before removing rotor.

PARKING BRAKE SHOE

< REMOVAL AND INSTALLATION >

3. Remove return springs (1) from the top of the parking brake shoes.

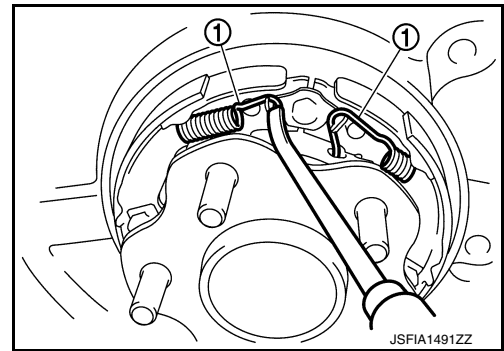

4. Remove the return spring (1) from the lower side of the parking brake shoes.

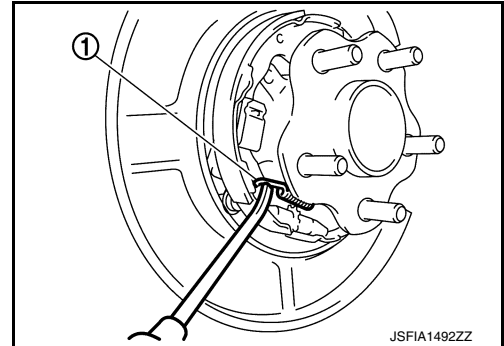

5. Remove springs (1) from the parking brake shoes.

CAUTION:

Do not drop the removed parts.

6. Remove parking brake shoes, adjuster, brake strut and toggle lever.

CAUTION:

- The front parking brake shoes are made of different materials than the rear parking brake shoes. Install the parking brake shoes in the proper location.
- Do not drop the removed parts.

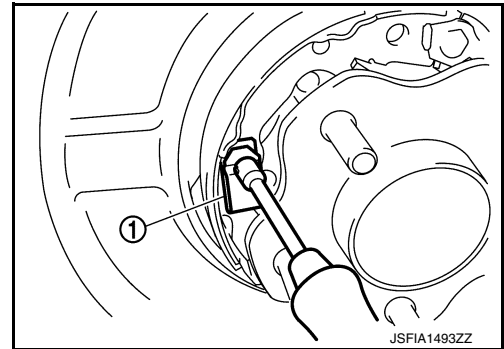

7. Press the rear cable spring (1) against spring tension to remove rear cable (3) from the clamp (A) of toggle lever (2).

CAUTION:

Do not bend rear cable.

8. Remove back plate (if necessary). Refer to [RAX-7. "Removal and Installation - Disc brake"](#).

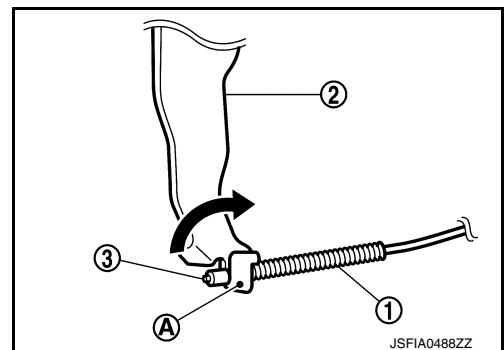

INSTALLATION

Installation is in the reverse order of removal.

- Apply PBC (Poly Butyl Cuprysil) grease or silicone-based grease to the back plate and brake shoe.

CAUTION:

The front parking brake shoes are made of different materials than the rear parking brake shoes. Install the parking brake shoes in the proper location.

PARKING BRAKE SHOE

< REMOVAL AND INSTALLATION >

- Assemble adjusters so that threaded part is expanded when rotating it in the direction shown by arrow.

(A) : For (RH) brake

(B) : For (LH) brake

↶ : Front

← : Adjuster expands

- Shorten adjuster by rotating it.
- When disassembling apply PBC (Poly Butyl Cuprysil) grease or silicone-based grease to threads.

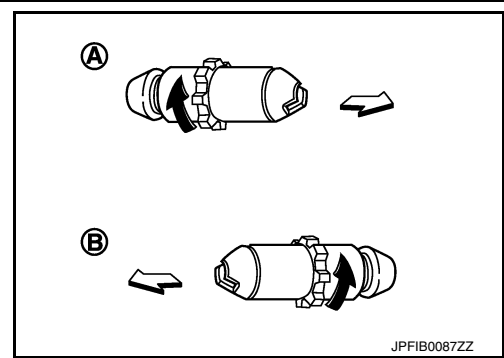

- Check that the component parts of the parking brake shoe are properly installed.
- Check parking brake shoe sliding surface and drum inner surface for grease. Make sure that grease does not adhere to the friction mating surfaces on the parking brake shoes and disc rotor.

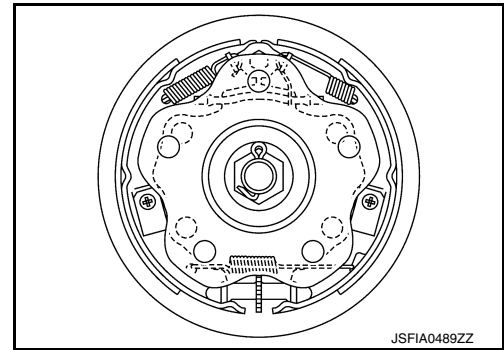

INFOID:0000000012787115

Inspection and Adjustment

INSPECTION AFTER REMOVAL

Lining Thickness Inspection

- Check thickness (A) of lining.

Wear limit thickness : Refer to [PB-13, "Parking Drum Brake"](#).

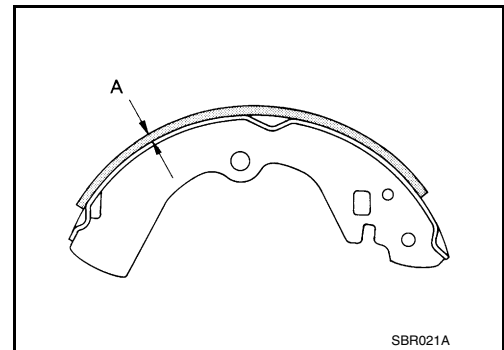

Drum Inner Diameter Inspection

- Check inner diameter (B) of drum using suitable tool.

Wear limit of inner diameter : Refer to [PB-13, "Parking Drum Brake"](#).

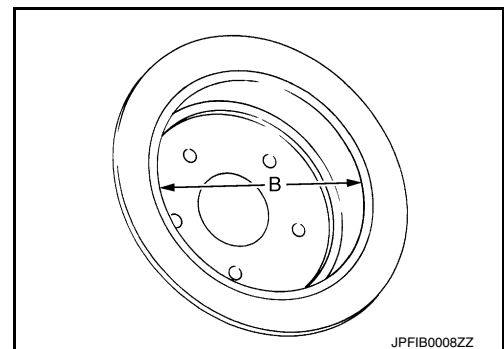

Other Inspections

Check the following items, and replace the parts (if necessary).

- Lining for excessive wear, damage, and peeling.
- Brake shoe sliding surface for excessive wear and damage.
- Anti-rattle pin for excessive wear, damage and rust.
- Return spring and spring for settling, excessive wear, damage, and rust.

PARKING BRAKE SHOE

< REMOVAL AND INSTALLATION >

- Adjuster for smoothness.
- Toggle lever and brake strut for excessive wear, damage and rust.
- Visually check inside of the drum for excessive wear, cracks, and damage.

ADJUSTMENT AFTER INSTALLATION

1. Adjust the parking brake lever stroke. Refer to [PB-4, "Inspection and Adjustment"](#).
2. Rotate the disc rotor to check that there is no drag. Install the plug. If any drag is found, follow the procedure described below.
 - a. Adjust parking brake stroke again.
 - b. Check rear disc brake.
3. Adjust the parking brake shoe. Refer to [PB-6, "Adjustment - Disc Brake"](#).

SERVICE DATA AND SPECIFICATIONS (SDS)

< SERVICE DATA AND SPECIFICATIONS (SDS)

SERVICE DATA AND SPECIFICATIONS (SDS)

SERVICE DATA AND SPECIFICATIONS (SDS)

Parking Drum Brake

INFOID:0000000012787116

Unit: mm (in)

Brake lining	Wear limit thickness	1.5 (0.059)
Drum (in disc)	Wear limit of inner diameter	173 (6.81)

Parking Brake Control

INFOID:0000000012787117

Item	Standard
Drum brake - number of notches [under force of 196 N (20.0 kg-f, 44.1 lb-f)]	8 – 9 notches
Disc brake - number of notches [under force of 196 N (20.0 kg-f, 44.1 lb-f)]	9 – 10 notches
Number of notches when brake warning lamp turns ON	1 notch