

ENGINE LUBRICATION & COOLING SYSTEMS

SECTION LC

GI

MA

EM

LC

CONTENTS

PRECAUTIONS	2	System Check	8	EC
Liquid Gasket Application Procedure	2	Water Pump	9	
PREPARATION	3	Thermostat	11	FE
Special Service Tools	3	Water Outlet	12	
ENGINE LUBRICATION SYSTEM	4	Radiator	13	CL
Lubrication Circuit	4	ENGINE COOLING SYSTEM	14	
Oil Pressure Check	4	Overheating Cause Analysis	14	
Oil Pump	5	SERVICE DATA AND SPECIFICATIONS (SDS)	15	MT
Oil Filter	7	Engine Lubrication System	15	
ENGINE COOLING SYSTEM	8	Engine Cooling System	15	AT
Cooling Circuit	8			

FA

RA

BR

ST

RS

BT

HA

EL

IDX

PRECAUTIONS

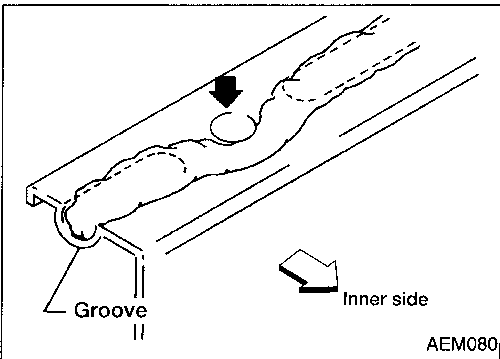
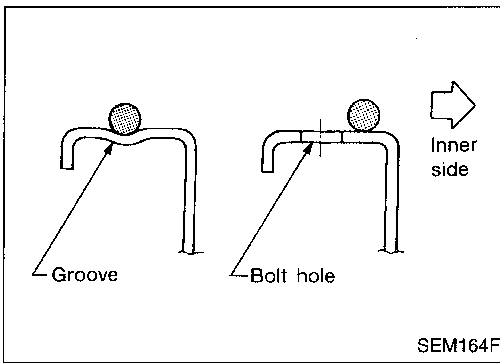

Liquid Gasket Application Procedure

- Use a scraper to remove all traces of old liquid gasket from mating surfaces and grooves. Also, completely clean any oil from these areas.
- Apply a continuous bead of liquid gasket to mating surfaces. **(Use Genuine RTV silicone sealant Part No. 999 MP-A7007, Three Bond TB1207D or equivalent.)**
 - For oil pan, be sure liquid gasket diameter is 4.0 to 5.0 mm (0.157 to 0.197 in).
 - For areas except oil pan, be sure liquid gasket diameter is 2.0 to 3.0 mm (0.079 to 0.118 in).
- Apply liquid gasket around the inner side of bolt holes (unless otherwise specified).
- Assembly should be done within 5 minutes after coating.
- Wait at least 30 minutes before refilling engine oil and engine coolant.

PREPARATION

Special Service Tools

The actual shapes of Kent-Moore tools may differ from those of special service tools illustrated here.

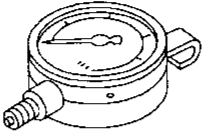
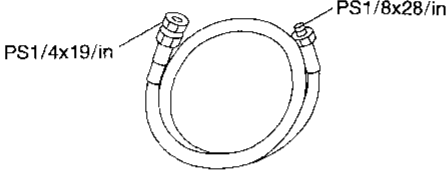
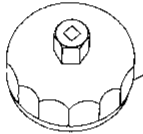
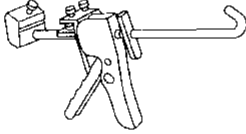
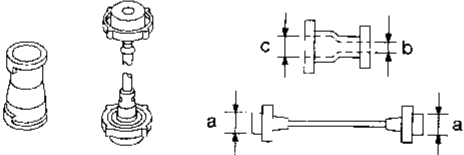
Tool number (Kent-Moore No.) Tool name	Description	GI MA EM LC
ST25051001 (J25695-1) Oil pressure gauge	 <p>NT050</p>	
ST25052000 (J25695-2) Hose	 <p>PS1/4x19/in</p> <p>PS1/8x28/in</p> <p>Adapting oil pressure gauge to cylinder block</p> <p>NT559</p>	EC FE CL
KV10115801 (J38956) Oil filter wrench	 <p>14 faces, Inner span: 64.3 mm (2.531 in) (Face to opposite face)</p> <p>NT362</p> <p>Removing oil filter</p>	MT AT
WS39930000 (—) Tube presser	 <p>NT052</p> <p>Pressing the tube of liquid gasket</p>	FA RA
EG17650301 (J33984-A) Radiator cap tester adapter	 <p>NT564</p> <p>Adapting radiator cap tester to radiator filler neck</p> <p>a: 28 (1.10) dia. b: 31.4 (1.236) dia. c: 41.3 (1.626) dia. Unit: mm (in)</p>	BR ST RS

BT

HA

EL

IDX

ENGINE LUBRICATION SYSTEM

Lubrication Circuit

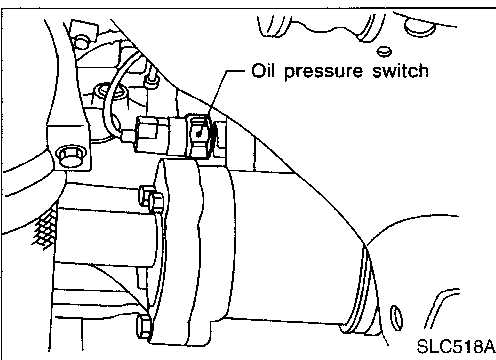
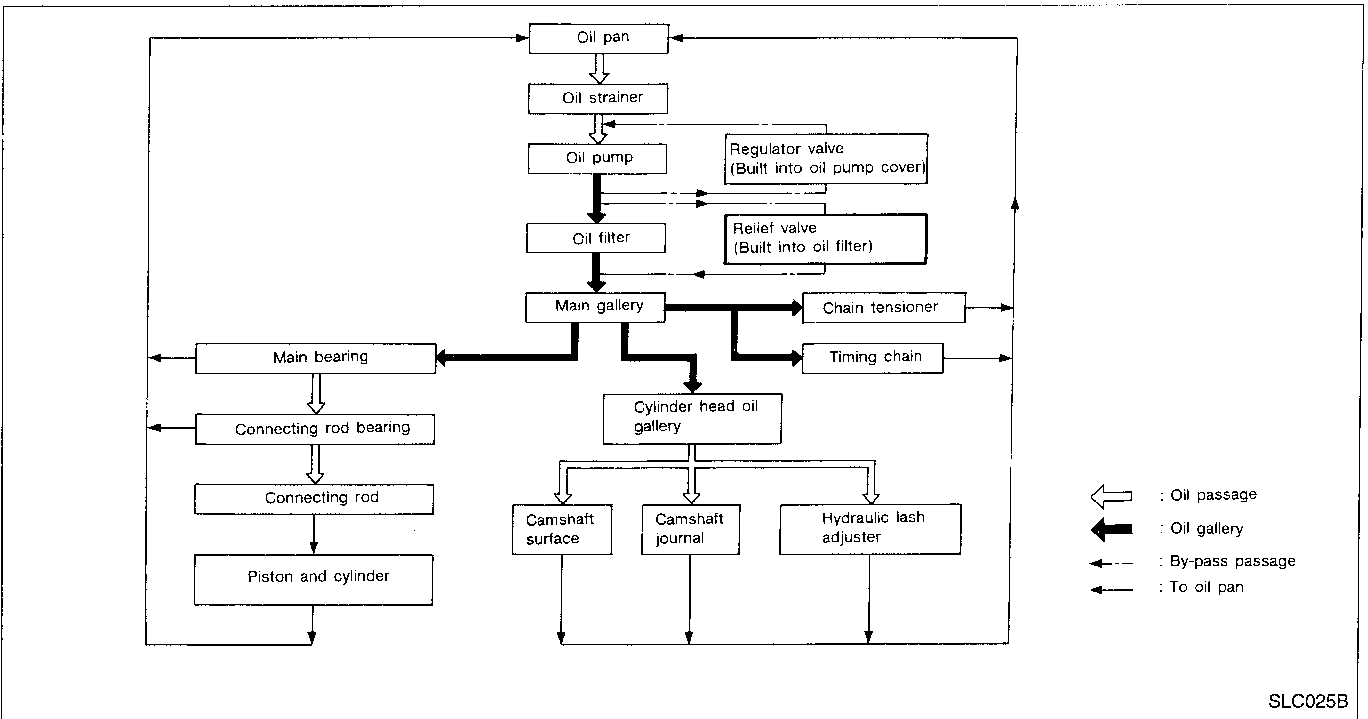
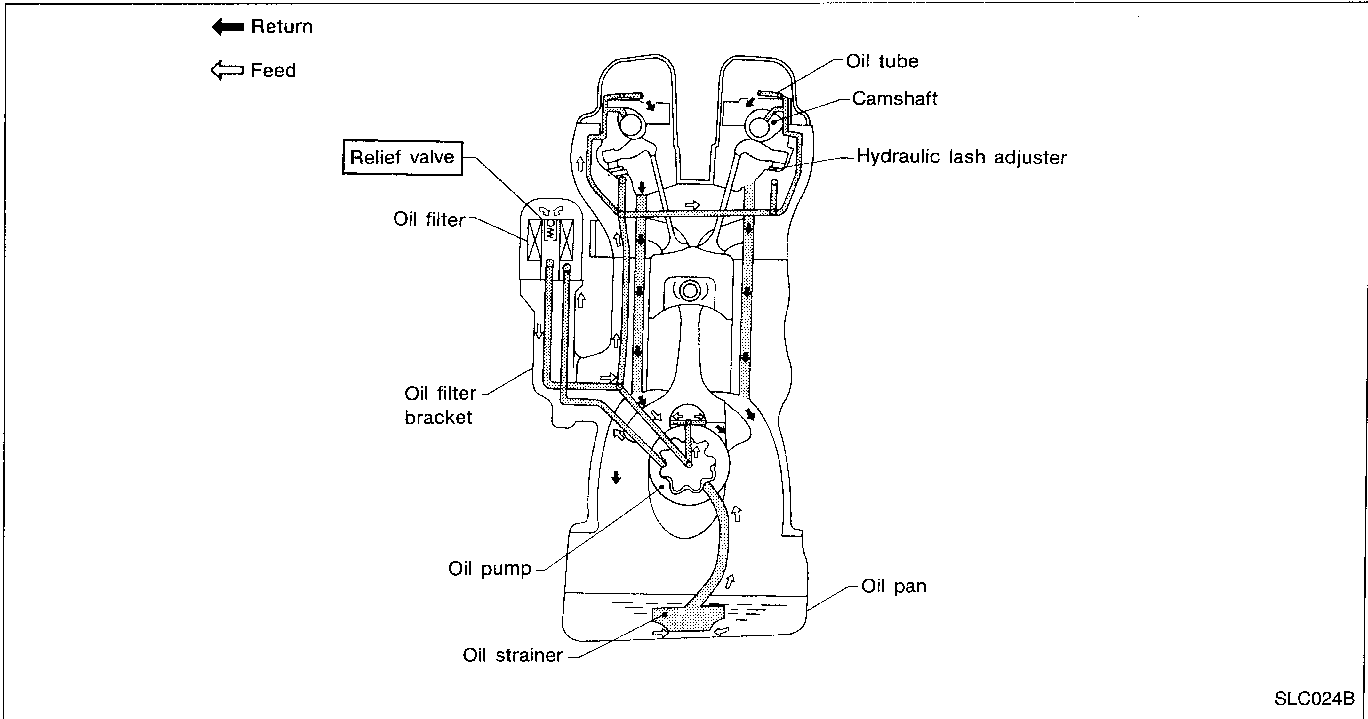

Oil Pressure Check

WARNING:

- Be careful not to burn yourself, as the engine and oil may be hot.
- For M/T models, put gearshift lever in Neutral "N" position. For A/T models, put selector lever in Park "P" position.

1. Check oil level.
2. Remove oil pressure switch.

ENGINE LUBRICATION SYSTEM

Oil Pressure Check (Cont'd)

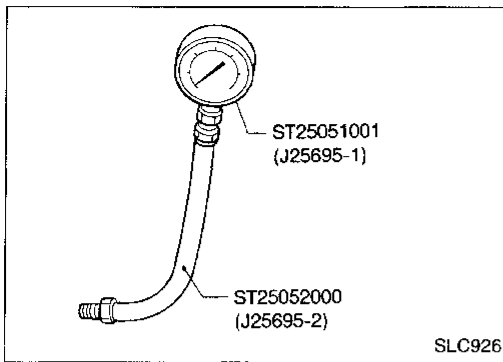

3. Install pressure gauge.
4. Start engine and warm it up to normal operating temperature.
5. Check oil pressure with engine running under no-load.

Engine speed rpm	Approximate discharge pressure kPa (kg/cm ² , psi)
Idle speed	More than 78 (0.8, 11)
3,200	314 - 392 (3.2 - 4.0, 46 - 57)

- If difference is extreme, check oil passage and oil pump for oil leaks.

6. Install oil pressure switch with sealant.

Oil Pump

REMOVAL

1. Remove drive belts.
2. Remove cylinder head. Refer to EM section ("Removal", "CYLINDER HEAD").
3. Remove oil pans. Refer to EM section ("Removal", "OIL PAN").
4. Remove oil strainer and baffle plate.
5. Remove front cover assembly.

DISASSEMBLY AND ASSEMBLY

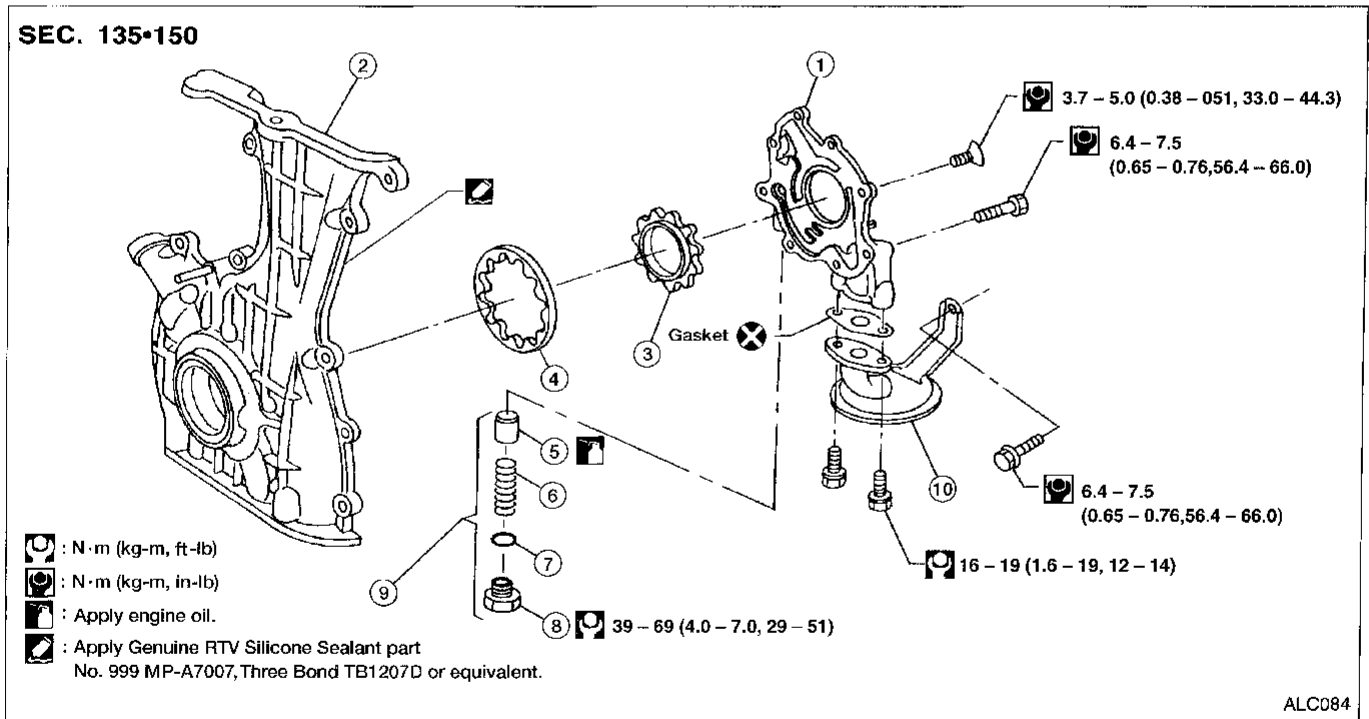

- ① Oil pump cover
- ② Front cover
- ③ Inner gear

- ④ Outer gear
- ⑤ Regulator valve
- ⑥ Spring

- ⑦ Shim
- ⑧ Plug
- ⑨ Regulator valve assembly
- ⑩ Oil strainer

ENGINE LUBRICATION SYSTEM

Oil Pump (Cont'd) INSPECTION

Using a feeler gauge, check the following clearances:

Standard clearance:

Unit: mm (in)

Body to outer gear radial clearance ①	0.114 - 0.200 (0.0045 - 0.0079)
Inner gear to outer gear tip clearance ②	Below 0.18 (0.0071)
Body to inner gear clearance ③	0.05 - 0.09 (0.0020 - 0.0035)
Body to outer gear axial clearance ④	0.05 - 0.11 (0.0020 - 0.0043)
Inner gear to brazed portion of housing clearance ⑤	0.045 - 0.091 (0.0018 - 0.0036)

- If the tip clearance (②) exceeds the limit, replace gear set.
- If body to gear clearances (① , ③ , ④ or ⑤) exceed the limit, replace front cover assembly.

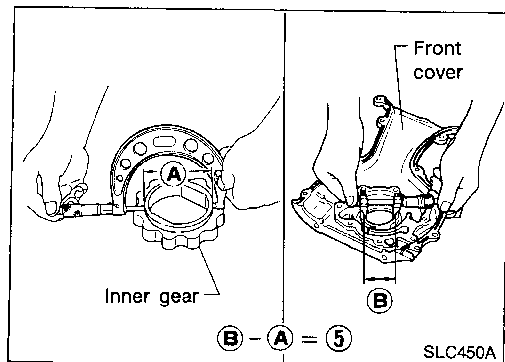
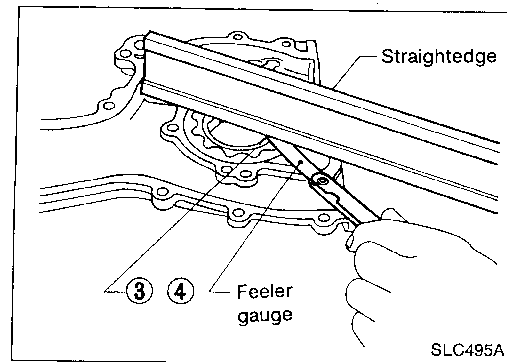
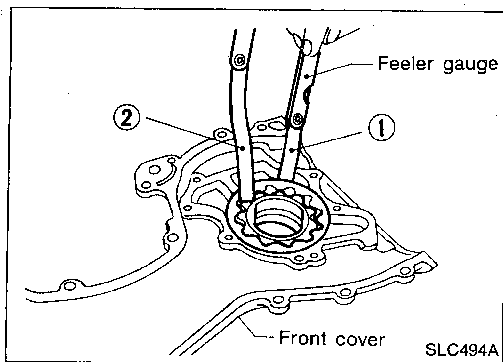

SLC854A

ENGINE LUBRICATION SYSTEM

Oil Pump (Cont'd)

REGULATOR VALVE INSPECTION

1. Visually inspect components for wear and damage.
2. Check oil pressure regulator valve sliding surface and valve spring.
3. Coat regulator valve with engine oil. Check that it falls smoothly into the valve hole by its own weight.

- **If damaged, replace regulator valve set or oil pump assembly.**

4. Check regulator valve to oil pump cover clearance.

Clearance:

⑥ : 0.040 - 0.097 mm (0.0016 - 0.0038 in)

- **If it exceeds the limit, replace oil pump cover.**

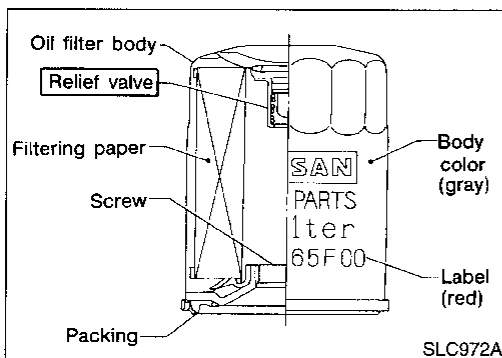
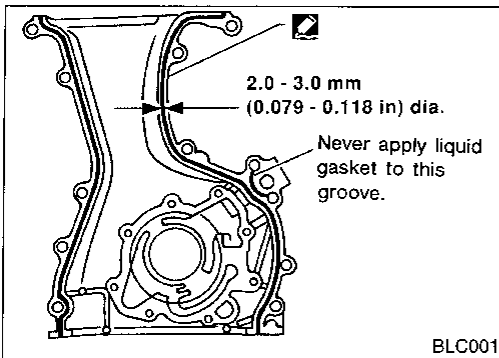
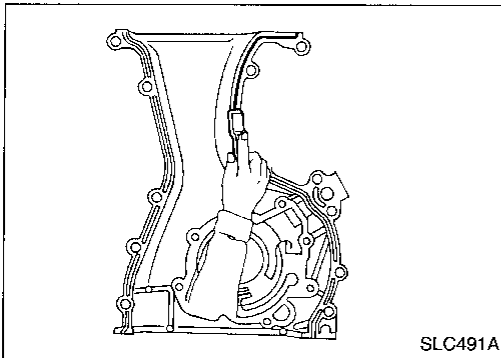
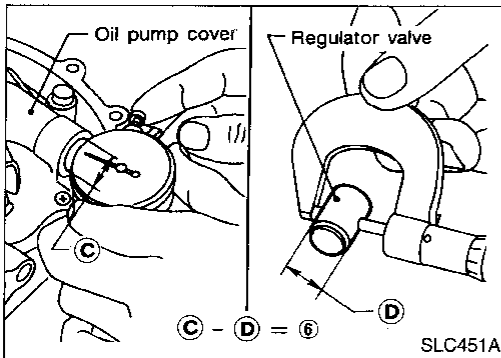
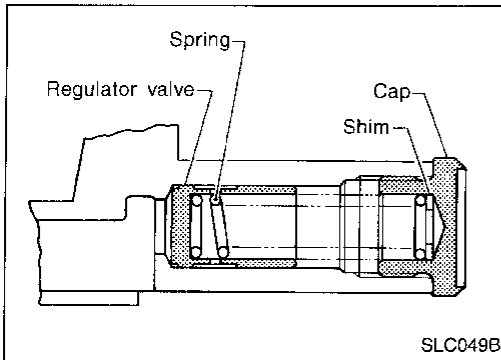

INSTALLATION

- Always replace oil seal and O-ring with new ones. Refer to EM section ("OIL SEAL REPLACEMENT").
- When installing oil pump, apply engine oil to gears.
- Be sure that O-rings are properly fitted.
- Use a scraper to remove old liquid gasket from mating surface of front cover.
- Also remove traces of liquid gasket from mating surface of cylinder block.

1. Apply a continuous bead of liquid gasket to mating surface of front cover assembly.
2. Installation is the reverse order of removal.

Oil Filter

The oil filter is a small, full-flow cartridge type and is provided with a relief valve.

- The new and previous oil filter designs differ from each other and are not interchangeable.
- Use Tool KV10115801 (J38956) for removing oil filter.

ENGINE COOLING SYSTEM

Cooling Circuit

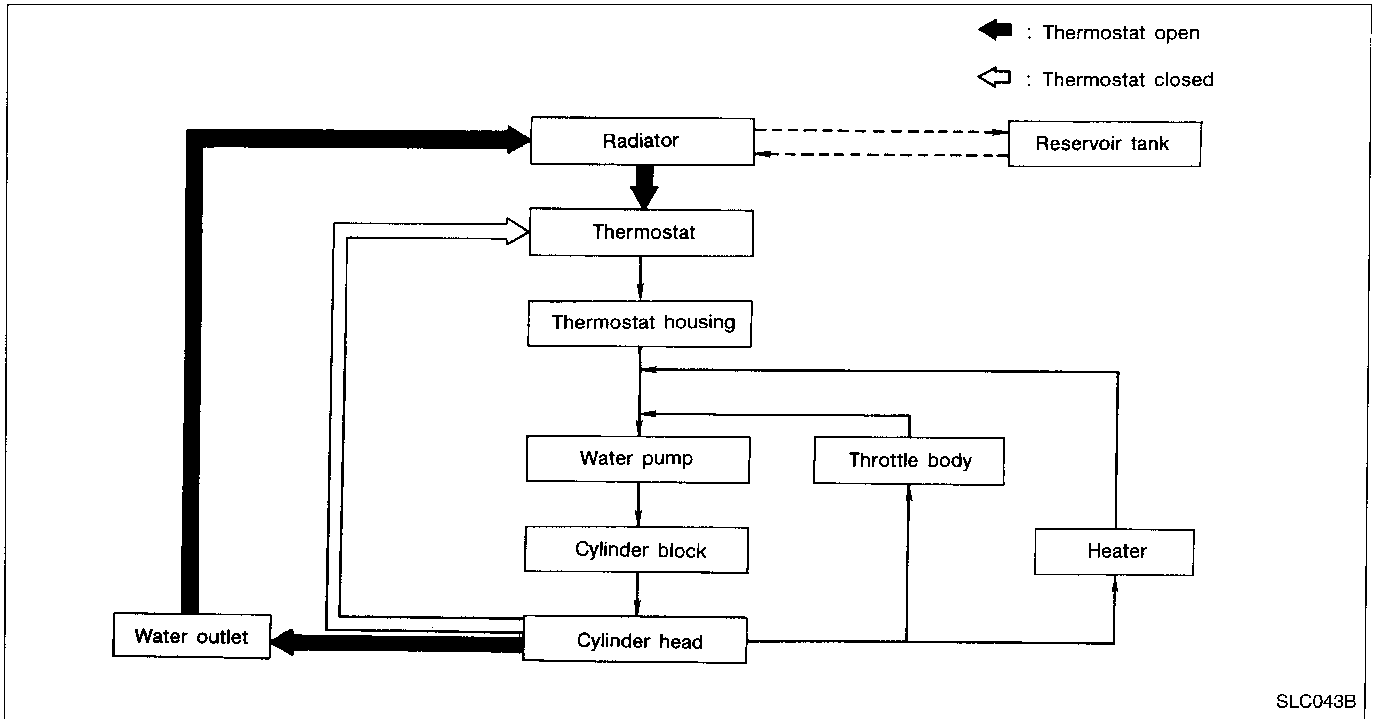

System Check

WARNING:

Never remove the radiator cap when the engine is hot. Serious burns could occur from high pressure coolant escaping from the radiator.

Wrap a thick cloth around the cap. Slowly turn it a quarter turn to allow built-up pressure to escape. Carefully remove the cap by turning it all the way.

CHECKING COOLING SYSTEM HOSES

Check hoses for the following:

- Improper attachment
- Leaks
- Cracks
- Damage
- Chafing
- Deterioration

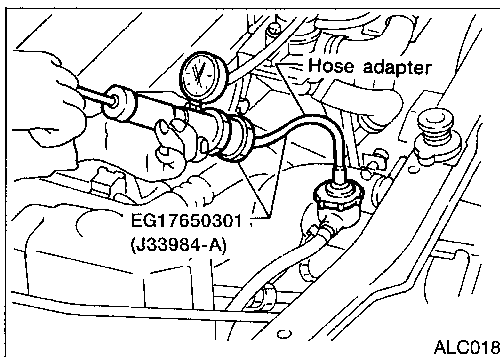

CHECKING COOLING SYSTEM FOR LEAKS

To check for leakage, apply pressure to the cooling system with a tester.

Testing pressure:

157 kPa (1.6 kg/cm², 23 psi)

CAUTION:

Higher pressure than specified may cause radiator damage.

ENGINE COOLING SYSTEM

System Check (Cont'd)

CHECKING RADIATOR CAP

To check radiator cap, apply pressure to cap with a tester.

Radiator cap relief pressure:

Standard

78 - 98 kPa (0.8 - 1.0 kg/cm², 11 - 14 psi)

Limit

59 - 98 kPa (0.6 - 1.0 kg/cm², 9 - 14 psi)

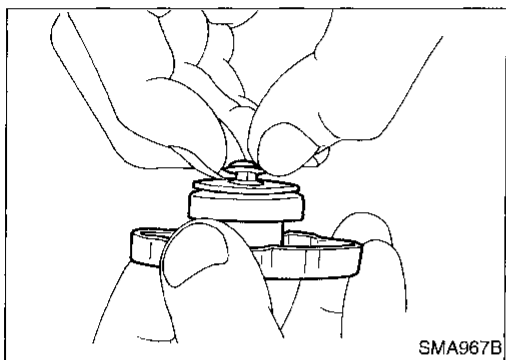
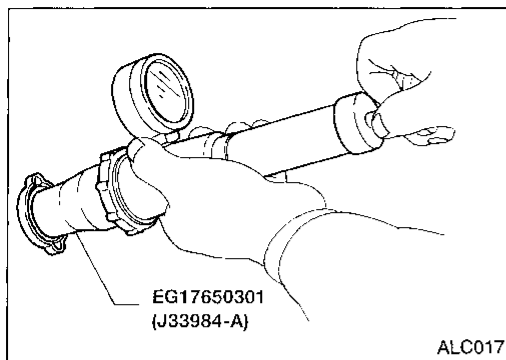

Pull the negative pressure valve to open it.
Check that it closes completely when released.

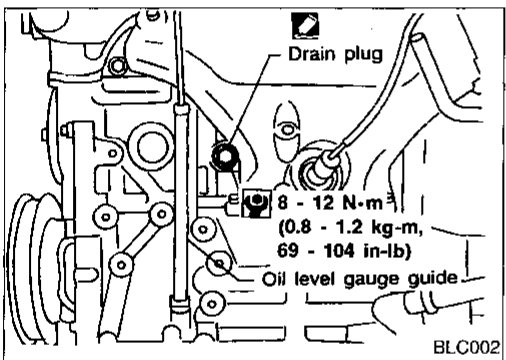

Water Pump

REMOVAL

1. Drain coolant from radiator and cylinder block.
Refer to MA section ("Changing Engine Coolant", "ENGINE MAINTENANCE").
2. Loosen water pump pulley bolts.
3. Remove drive belts.
4. Remove front RH wheel, engine side cover and front cover.
5. Remove three lower water pump bolts.

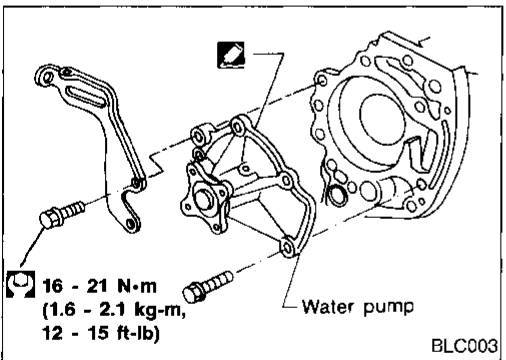

6. Position jack to support engine and remove front engine mount.
7. Remove remaining water pump bolt to remove water pump.

CAUTION:

- When removing water pump assembly, be careful not to get coolant on drive belt.
- Water pump cannot be disassembled and should be replaced as a unit.
- After installing water pump, connect hose and clamp securely, then check for leaks using radiator cap tester.
- Use Genuine RTV silicone sealant Part No. 999 MP-A7007, Three Bond TB1207D or equivalent.

GI

MA

EM

LC

EC

FE

CL

MT

AT

FA

RA

BR

ST

RS

BT

HA

EL

IDX

ENGINE COOLING SYSTEM

Water Pump (Cont'd)

INSPECTION

- Check body assembly for rust or corrosion.
- Check for rough operation due to excessive end play.

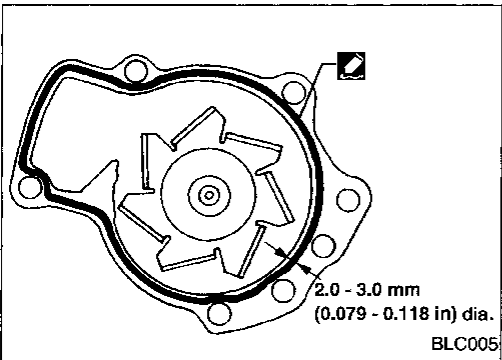
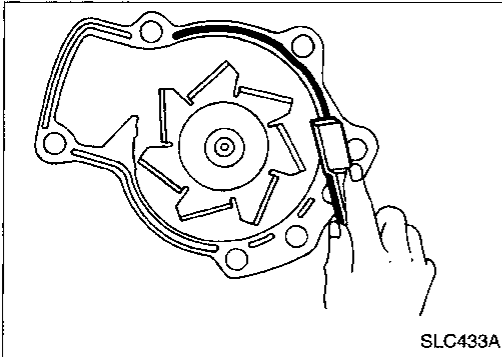
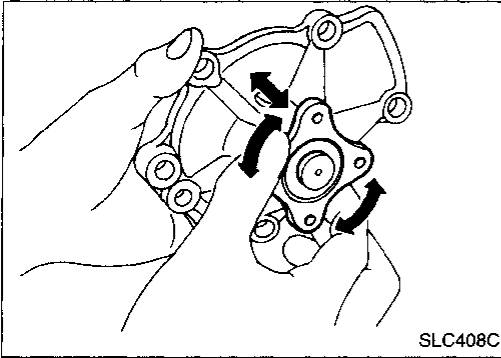

INSTALLATION

1. Use a scraper to remove liquid gasket from water pump.
 - Also remove traces of liquid gasket from mating surface of cylinder block.

2. Apply a continuous bead of liquid gasket to mating surface of water pump.

- Use Genuine RTV silicone sealant Part No. 999 MP-A7007, Three Bond TB1207D or equivalent.

When filling radiator with coolant, refer to MA section ("Changing Engine Coolant", "ENGINE MAINTENANCE").
When installing drive belts, refer to MA section ("Checking Drive Belts", "ENGINE MAINTENANCE").

ENGINE COOLING SYSTEM

Thermostat

SEC. 210

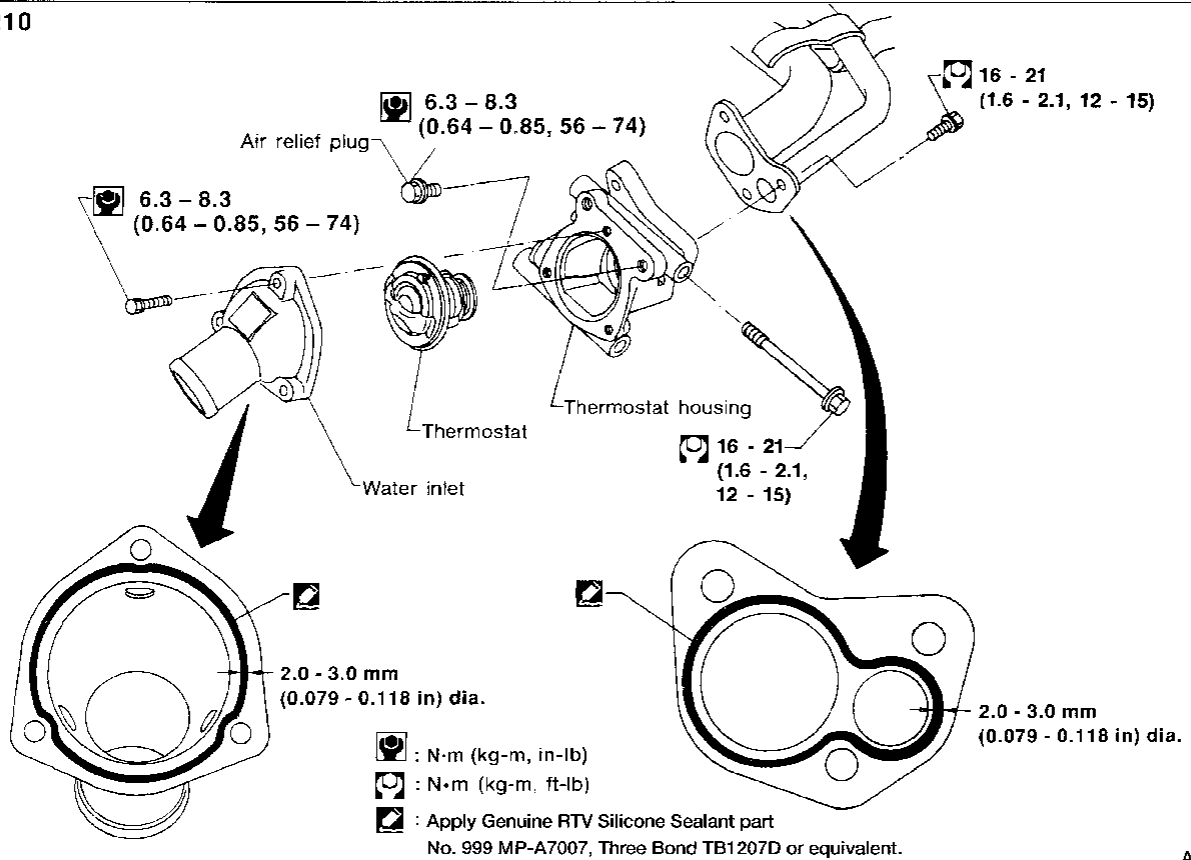

Be careful not to spill coolant over engine compartment. Use a rag to absorb coolant.

REMOVAL AND INSTALLATION

1. Drain engine coolant.
2. Remove lower radiator hose.
3. Remove water inlet, then take out thermostat.

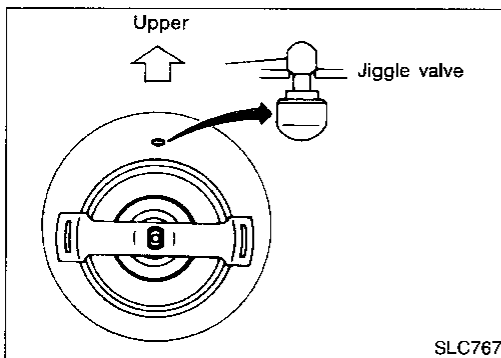

4. Install thermostat with jiggle valve or air bleeder at upper side.
 - Apply a continuous bead of liquid gasket to mating surface of water inlet.
 - After installation, run engine for a few minutes, and check for leaks.

ENGINE COOLING SYSTEM

Thermostat (Cont'd)

INSPECTION

1. Check for valve seating condition at normal room temperature. It should seat tightly.
2. Check valve opening temperature and valve lift.

Valve opening temperature	°C (°F)	76.5 (170)
Valve lift	mm/°C (in/°F)	More than 8/90 (0.31/194)

3. Then check if valve closes at 5°C (9°F) below valve opening temperature.

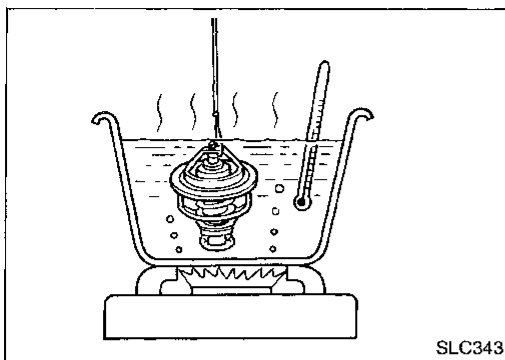

Water Outlet

INSPECTION

Visually inspect for water leaks. If there is leakage, apply liquid gasket.

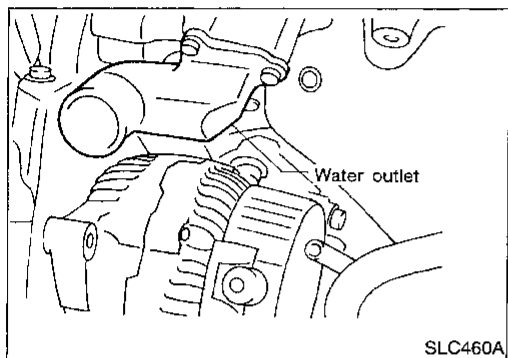

INSTALLATION

1. Use a scraper to remove old liquid gasket from water outlet.
 - **Also remove traces of liquid gasket from mating surface of cylinder head.**
2. Apply a continuous bead of liquid gasket to mating surface of water outlet.
 - **Use Genuine RTV silicone sealant Part No. 999 MP-A7007, Three Bond TB1207D or equivalent.**
 - **When installing, tighten water outlet bolts to the specified torque.**

⚙️: 6.3 - 8.3 N·m (0.64 - 0.85 kg-m, 55.6 - 73.8 in-lb)

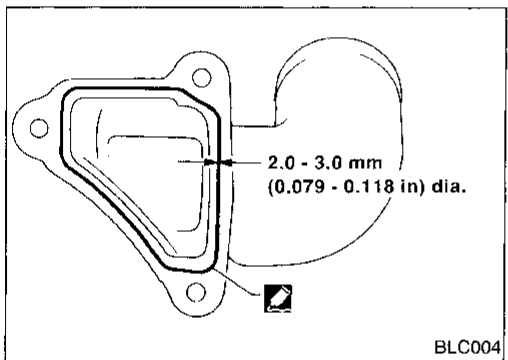

ENGINE COOLING SYSTEM

Radiator

SEC. 214

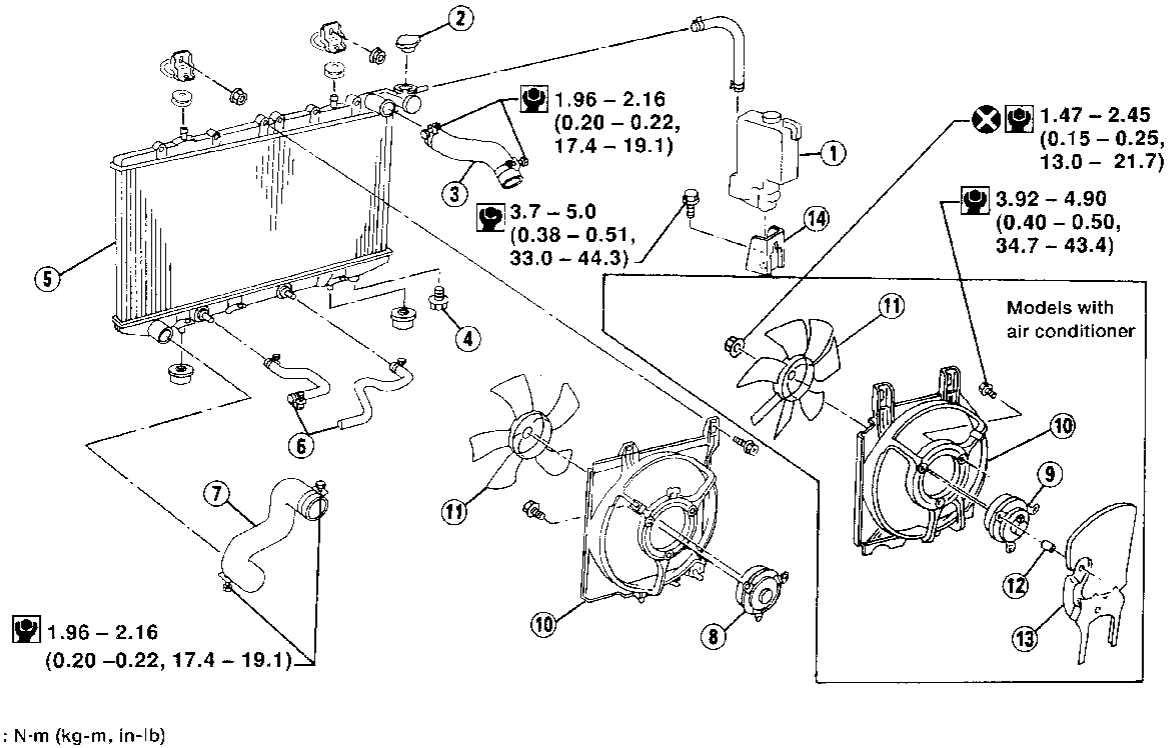

ALC093

- | | | |
|-----------------------|---------------------------------|----------------------------|
| ① Reservoir tank | ⑥ Oil cooler hoses (A/T models) | ⑪ Cooling fan |
| ② Radiator cap | ⑦ Lower radiator hose | ⑫ Shield spacer |
| ③ Upper radiator hose | ⑧ Cooling fan motor-1 | ⑬ Cooling fan motor shield |
| ④ Radiator drain plug | ⑨ Cooling fan motor-2 | ⑭ Reservoir tank bracket |
| ⑤ Radiator | ⑩ Radiator shroud | |

Cooling fan control system

Cooling fans are controlled by the ECM. For details, refer to EC section ("Cooling Fan", "TROUBLE DIAGNOSIS FOR DTC P1900").

Refilling engine coolant

For details on refilling engine coolant, refer to MA section ("Changing Engine Coolant", "ENGINE MAINTENANCE").

GI

MA

EM

LC

EC

FE

CL

MT

AT

FA

RA

BR

ST

RS

BT

HA

EL

IDX

ENGINE COOLING SYSTEM

Overheating Cause Analysis

	Symptom		Check items		
Cooling system parts malfunction	Poor heat transfer	Water pump malfunction	Worn or loose drive belt	—	
		Thermostat stuck closed	—		
		Damaged fins	Dust contamination or paper clogging		—
			Mechanical damage		
	Reduced air flow	Clogged radiator cooling tube	Excess foreign material (rust, dirt, sand, etc.)	—	
		Cooling fan does not operate	—		
		High resistance to fan rotation			
	Reduced air flow	Damaged fan blades	—	—	
		Damaged radiator shroud	—		
	Improper coolant mixture ratio	—	—	—	
	Poor coolant quality	—	—	—	
	Insufficient coolant	Coolant leaks	Cooling hose	Loose clamp	—
				Cracked hose	
			Water pump	Poor sealing	
			Radiator cap	Loose	
Poor sealing					
Radiator			O-ring for damage, deterioration or improper fitting		
		Cracked radiator tank			
Reservoir tank		Cracked radiator core			
	Cracked reservoir tank				
Overflowing reservoir tank	Exhaust gas leaks into cooling system	Cylinder head deterioration	—		
		Cylinder head gasket deterioration			
Except cooling system parts malfunction	—	Overload on engine	Abusive driving	High engine rpm under no load	
				Driving in low gear for extended time	
				Driving at extremely high speed	
			Powertrain system malfunction	—	
			Installed improper size wheels and tires		
	Dragging brakes				
	Improper ignition timing				
	Blocked bumper	—			
	Blocked or restricted air flow	Blocked radiator grille	Installed car brassiere	—	
			Mud contamination or paper clogging		
Blocked radiator		—			
Blocked condenser		—			
Installed large fog lamp		—			

SERVICE DATA AND SPECIFICATIONS (SDS)

Engine Lubrication System

Oil pressure check

Engine speed rpm	Approximate discharge pressure kPa (kg/cm ² , psi)
Idle speed 3,200	More than 78 (0.8, 11) 314 - 392 (3.2 - 4.0, 46 - 57)

Regulator valve inspection

Unit: mm (in)

Regulator valve to oil pump cover clearance	0.040 - 0.097 (0.0016 - 0.0038)
--	---------------------------------

Oil pump inspection

Unit: mm (in)

Body to outer gear radial clear- ance	0.114 - 0.200 (0.0045 - 0.0079)
Inner gear to outer gear tip clearance	Below 0.18 (0.0071)
Body to inner gear clearance	0.05 - 0.09 (0.0020 - 0.0035)
Body to outer gear axial clearance	0.05 - 0.11 (0.0020 - 0.0043)
Inner gear to brazed portion of housing clearance	0.045 - 0.091 (0.0018 - 0.0036)

Engine Cooling System

Thermostat

Valve opening temperature	°C (°F)	76.5 (170)
Valve lift	mm/°C (in/°F)	More than 8/90 (0.31/194)

Radiator

Unit: kPa (kg/cm², psi)

Cap relief pressure	Standard	78 - 98 (0.8 - 1.0, 11 - 14)
	Limit	59 - 98 (0.6 - 1.0, 9 - 14)
Leakage test pressure		157 (1.6, 23)

GI

MA

EM

LC

EC

FE

CL

WT

AT

FA

RA

BR

ST

RS

BT

HA

EL

IDX