

A
EM
C
D
E
F
G
H
I
J
K
L
M

SECTION **EM**

ENGINE MECHANICAL

CONTENTS

QG18DE		
PRECAUTIONS	4	
Parts Requiring Angular Tightening	4	
Precautions for Liquid Gasket	4	
REMOVAL OF LIQUID GASKET SEALING	4	
LIQUID GASKET APPLICATION PROCEDURE	4	
Rocker Cover Bolts	5	
PREPARATION	6	
Special Service Tools	6	
Commercial Service Tools	8	
NOISE, VIBRATION, AND HARSHNESS (NVH)		
TROUBLESHOOTING	10	
Noise, Vibration and Harshness (NVH) Trouble-		
shooting	10	
NVH TROUBLESHOOTING — ENGINE NOISE ..	10	
OUTER COMPONENT PARTS	12	
Removal and Installation	12	
OIL PAN	16	
Components	16	
Removal	16	
Installation	17	
FUEL INJECTOR AND FUEL TUBE	19	
Removal and Installation	19	
REMOVAL	19	
INSTALLATION	20	
INSPECTION AFTER INSTALLATION	22	
ROCKER COVER	23	
Removal and Installation	23	
REMOVAL	23	
INSTALLATION	24	
CAMSHAFT	26	
Removal and Installation	26	
REMOVAL	26	
INSTALLATION	29	
INSPECTION AFTER REMOVAL	32	
Valve Clearance	35	
INSPECTION	35	
ADJUSTING	36	
TIMING CHAIN	39	
Components	39	
Removal	40	
INSPECTION AFTER REMOVAL	45	
INSTALLATION	45	
INSPECTION AFTER INSTALLATION	48	
OIL SEAL	49	
Replacement	49	
VALVE OIL SEAL	49	
FRONT OIL SEAL	49	
REAR OIL SEAL	51	
CYLINDER HEAD	52	
On-Vehicle Service	52	
CHECKING COMPRESSION PRESSURE	52	
Removal and Installation	53	
REMOVAL	53	
INSTALLATION	54	
Disassembly and Assembly	56	
DISASSEMBLY	56	
ASSEMBLY	57	
Inspection after Disassembly	58	
CYLINDER HEAD DISTORTION	58	
VALVE GUIDE CLEARANCE	58	
VALVE GUIDE REPLACEMENT	59	
VALVE SEATS	60	
REPLACING VALVE SEAT FOR SERVICE		
PARTS	60	
VALVE DIMENSIONS	61	
VALVE SPRING	61	
ENGINE ASSEMBLY	63	
Removal and Installation	63	
REMOVAL	64	
INSTALLATION	66	
CYLINDER BLOCK	67	
Components	67	
Removal and Installation	68	
Disassembly	68	
PISTON AND CRANKSHAFT	68	
Inspection	69	
PISTON AND PISTON PIN CLEARANCE	69	
PISTON RING SIDE CLEARANCE	70	
PISTON RING END GAP	70	

CONNECTING ROD BEND AND TORSION	70
CYLINDER BLOCK DISTORTION AND WEAR..	71
PISTON-TO-BORE CLEARANCE	71
CRANKSHAFT	72
BEARING CLEARANCE	73
CONNECTING ROD BUSHING CLEARANCE (SMALL END)	76
REPLACEMENT OF CONNECTING ROD BUSHING (SMALL END)	76
FLYWHEEL RUNOUT	77
Assembly	77
PISTON	77
CRANKSHAFT	78
SERVICE DATA AND SPECIFICATIONS (SDS)	81
General Specifications	81
Compression Pressure	81
Cylinder Head	81
Valve	82
VALVE	82
VALVE SPRING	82
VALVE LIFTER	82
VALVE CLEARANCE	82
VALVE GUIDE	83
AVAILABLE SHIMS	83
VALVE SEAT	85
VALVE SEAT RESURFACE LIMIT	86
Camshaft and Camshaft Bearing	86
Cylinder Block	87
Piston, Piston Ring and Piston Pin	87
PISTON	87
PISTON RING	88
PISTON PIN	88
Connecting Rod	88
Crankshaft	89
Main Bearing	90
STANDARD	90
UNDERSIZE	90
Connecting Rod Bearing	90
STANDARD SIZE	90
UNDERSIZE	90
Bearing Clearance	90
Miscellaneous Components	90

QR25DE

PRECAUTIONS	91
Precautions for Draining Coolant	91
Precautions for Disconnecting Fuel Piping	91
Precautions for Removal and Disassembly	91
Precautions for Inspection, Repair and Replace- ment	91
Precautions for Assembly and Installation	91
Parts Requiring Angular Tightening	91
Precautions for Liquid Gasket	92
REMOVAL OF LIQUID GASKET SEALING	92
LIQUID GASKET APPLICATION PROCEDURE..	92
PREPARATION	93
Special Service Tools	93
Commercial Service Tools	96

NOISE, VIBRATION, AND HARSHNESS (NVH)	
TROUBLESHOOTING	98
NVH Troubleshooting —Engine Noise	98
Use the Chart Below to Help You Find the Cause of the Symptom.	99
DRIVE BELTS	100
Checking Drive Belts	100
Tension Adjustment	100
Removal and Installation	100
REMOVAL	100
INSTALLATION	101
Removal and Installation of Drive Belt Auto-ten- sioner	101
REMOVAL	101
INSTALLATION	101
AIR CLEANER AND AIR DUCT	103
Removal and Installation	103
REMOVAL	103
INSTALLATION	104
CHANGING THE AIR CLEANER ELEMENT ..	104
INTAKE MANIFOLD	105
Removal and Installation	105
REMOVAL	105
INSPECTION AFTER REMOVAL	107
INSTALLATION	108
INSPECTION AFTER INSTALLATION	109
EXHAUST MANIFOLD AND THREE WAY CATA- LYST	110
Removal and Installation	110
REMOVAL	110
INSPECTION AFTER REMOVAL	111
INSTALLATION	111
OIL PAN AND OIL STRAINER	112
Removal and Installation	112
REMOVAL	112
INSPECTION AFTER REMOVAL	113
INSTALLATION	113
INSPECTION AFTER INSTALLATION	114
IGNITION COIL	115
Removal and Installation	115
REMOVAL	115
INSTALLATION	115
SPARK PLUG	116
Removal and Installation	116
REMOVAL	116
INSPECTION AFTER REMOVAL	116
INSTALLATION	117
FUEL INJECTOR AND FUEL TUBE	118
Removal and Installation	118
REMOVAL	118
INSTALLATION	119
INSPECTION AFTER INSTALLATION	120
ROCKER COVER	121
Removal and Installation	121
REMOVAL	121
INSTALLATION	122
CAMSHAFT	123
Removal and Installation	123
REMOVAL	123

INSPECTION AFTER REMOVAL	125	HOW TO SELECT A CONNECTING ROD BEAR-	
INSTALLATION	128	ING	170
Valve Clearance	130	HOW TO SELECT A MAIN BEARING	172
INSPECTION	130	Inspection After Disassembly	175
VALVE ADJUSTMENT	132	CRANKSHAFT SIDE CLEARANCE	175
TIMING CHAIN	134	CONNECTING ROD SIDE CLEARANCE	176
Removal and Installation	134	PISTON AND PISTON PIN CLEARANCE	176
REMOVAL	135	PISTON RING SIDE CLEARANCE	177
INSPECTION AFTER REMOVAL	137	PISTON RING END GAP	177
INSTALLATION	138	CONNECTING ROD BEND AND TORSION ...	177
OIL SEAL	142	CONNECTING ROD BEARING (BIG END)	178
Removal and installation of Valve Oil Seal	142	CONNECTING ROD BUSHING OIL CLEAR-	
REMOVAL	142	ANCE (SMALL END)	178
INSTALLATION	142	CYLINDER BLOCK DISTORTION	179
Removal and Installation of Front Oil Seal	142	INNER DIAMETER OF MAIN BEARING HOUS-	
REMOVAL	142	ING	180
INSTALLATION	143	PISTON TO CYLINDER BORE CLEARANCE .	180
Removal and Installation of Rear Oil Seal	144	OUTER DIAMETER OF CRANKSHAFT MAIN	
REMOVAL	144	JOURNAL	181
INSTALLATION	144	OUTER DIAMETER OF CRANKSHAFT PIN	
CYLINDER HEAD	145	JOURNAL	182
On-Vehicle Service	145	OUT-OF-ROUND AND TAPER OF CRANK-	
CHECKING COMPRESSION PRESSURE	145	SHAFT	182
Removal and Installation	147	CRANKSHAFT RUNOUT	182
REMOVAL	148	OIL CLEARANCE OF CONNECTING ROD	
INSPECTION AFTER REMOVAL	148	BEARING	182
INSTALLATION	148	OIL CLEARANCE OF MAIN BEARING	183
Disassembly and Assembly	149	CRUSH HEIGHT OF MAIN BEARING	183
DISASSEMBLY	150	OUTER DIAMETER OF LOWER CYLINDER	
ASSEMBLY	150	BLOCK MOUNTING BOLT	184
Inspection After Disassembly	151	OUTER DIAMETER OF CONNECTING ROD	
CYLINDER HEAD DISTORTION	151	BOLT	184
VALVE DIMENSIONS	151	MOVEMENT AMOUNT OF FLYWHEEL (M/T	
VALVE GUIDE CLEARANCE	152	MODEL)	184
VALVE GUIDE REPLACEMENT	152	SERVICE DATA AND SPECIFICATIONS (SDS) ...	186
VALVE SEAT CONTACT	153	Standard and Limit	186
VALVE SEAT REPLACEMENT	153	GENERAL SPECIFICATIONS	186
VALVE SPRING SQUARENESS	154	DRIVE BELTS	186
VALVE SPRING DIMENSIONS AND VALVE		INTAKE MANIFOLD AND EXHAUST MANI-	
SPRING PRESSURE LOAD	154	FOLD	186
ENGINE ASSEMBLY	156	SPARK PLUG	186
Removal and Installation	156	CYLINDER HEAD	187
REMOVAL	157	VALVE	187
INSTALLATION	159	CAMSHAFT AND CAMSHAFT BEARING	190
INSPECTION AFTER INSTALLATION	159	CYLINDER BLOCK	190
CYLINDER BLOCK	160	PISTON, PISTON RING, AND PISTON PIN ...	191
Disassembly and Assembly	160	CONNECTING ROD	192
DISASSEMBLY	161	CRANKSHAFT	193
ASSEMBLY	164	MAIN BEARING	194
How to Select Piston and Bearing	168	CONNECTING ROD BEARING	195
DESCRIPTION	168	Miscellaneous Components	195
HOW TO SELECT A PISTON	169		

PRECAUTIONS

Parts Requiring Angular Tightening

EBS00CE6

- Use an angle wrench for the final tightening of the following engine parts:
 - Cylinder head bolts
 - Main bearing cap bolts
 - Connecting rod cap nuts
- Do not use a torque value for final tightening.
- The torque value for these parts are for a preliminary step.
- Ensure thread and seat surfaces are clean and coated with engine oil.

Precautions for Liquid Gasket REMOVAL OF LIQUID GASKET SEALING

EBS00EXN

- After removing the mounting bolts and nuts, separate the mating surface using a seal cutter and remove the liquid gasket sealing.

CAUTION:

Be careful not to damage the mating surfaces.

- In areas where the cutter is difficult to use, use a plastic hammer to lightly tap (1) the cutter where the Silicone RTV Sealant is applied. Use a plastic hammer to slide the cutter (2) by tapping on the side.

CAUTION:

If for some unavoidable reason a tool such as a flat-bladed screwdriver is used, be careful not to damage the mating surfaces.

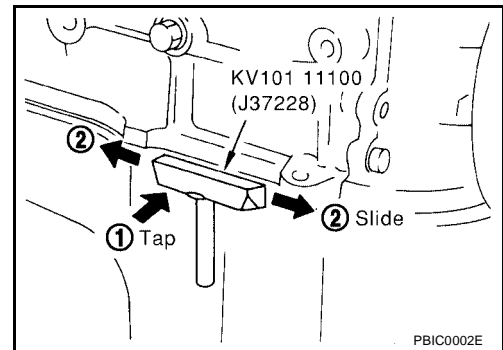

LIQUID GASKET APPLICATION PROCEDURE

1. Using a scraper, remove the old Silicone RTV Sealant adhering to the gasket application surface and the mating surface.
- Remove the sealant completely from the groove of the gasket application surface, mounting bolts, and bolt holes.
2. Thoroughly clean the gasket application surface and the mating surface and remove adhering moisture, grease and foreign materials.
3. Attach the sealant tube to the tube presser.
Use Genuine Silicone RTV Sealant or equivalent. Refer to [GI-44, "RECOMMENDED CHEMICAL PRODUCTS AND SEALANTS"](#).

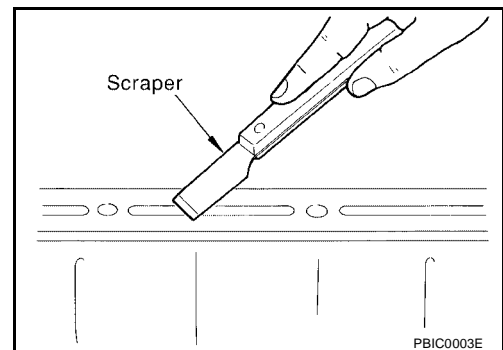

4. Apply the sealant using Tool without breaks to the specified location with the specified dimensions.

Tube presser

WS39930000 (-)

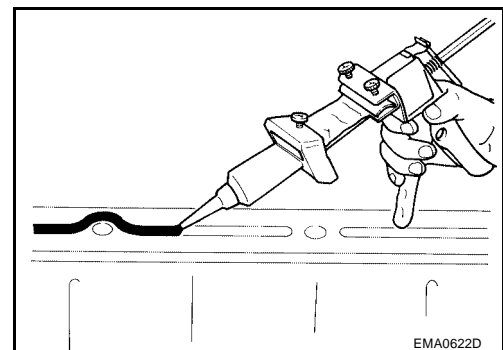

PRECAUTIONS

[QG18DE]

- If there is a groove for the sealant application, apply the sealant to the groove.
- As for the bolt holes, normally apply the sealant inside the holes. If specified, it should be applied outside the holes. Make sure to read the text of this manual.
- Within five minutes of the sealant application, install the mating component.
- If the sealant protrudes, wipe it off immediately.
- Do not retighten after the installation.
- After 30 minutes or more have passed from the installation, fill the engine with the specified oil and coolant. Refer to [MA-13](#), "[RECOMMENDED FLUIDS AND LUBRICANTS](#)".

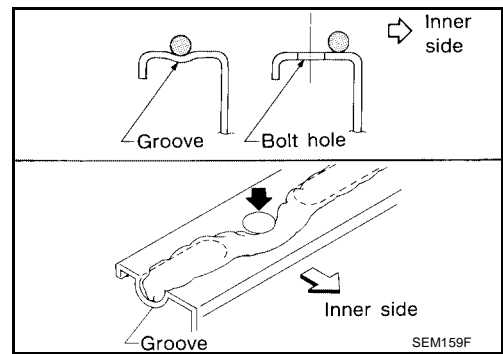

CAUTION:

Follow all specific instructions in this manual.

Rocker Cover Bolts

EBS00EWP

NOTE:

Remove and install rocker cover bolts with a socket or wrench only.

PREPARATION

[QG18DE]

PF0:00002

EBS00CE8

PREPARATION

Special Service Tools

The actual shapes of Kent-Moore tools may differ from those of special service tools illustrated here.

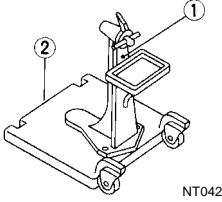
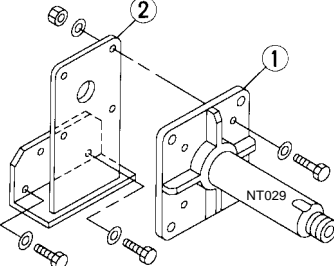
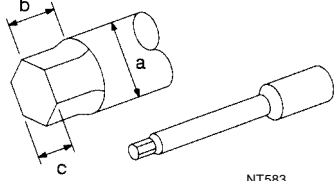
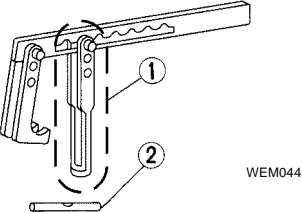
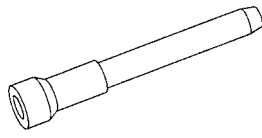
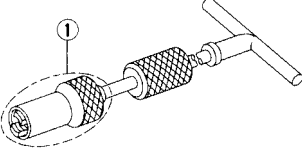
Tool number (Kent-Moore No.) Tool name	Description
ST0501S000 (—) Engine stand assembly 1. ST05011000 (—) Engine stand 2. ST05012000 (—) Base	Disassembling and assembling 
Engine attachment assembly 1. KV10106500 (—) Engine attachment 2. KV10113300 (—) Sub-attachment	Overhauling engine 
ST10120000 (J24239-O1) Cylinder head bolt wrench	Loosening and tightening cylinder head bolt a: 13 mm (0.51 in) dia. b: 12 mm (0.47 in) c: 10 mm (0.39 in) 
KV10116200 (J26336-B) Valve spring compressor 1. KV10115900 (J26336-20) Attachment 2. KV10109220 (—) Adapter	Disassembling valve mechanism 
KV10115600 (J38958) Valve oil seal drift	Installing valve oil seal 
KV10107902 (J38959) Valve oil seal puller 1. KV10116100 Valve oil seal puller adapter	Displacing valve lip seal 

PREPARATION

[QG18DE]

Tool number (Kent-Moore No.) Tool name	Description	A
KV101151S0 (J38972) Lifter stopper set 1. KV10115110 Camshaft pliers 2. KV10115120 Lifter stopper	Changing shims	EM C
EM03470000 (J8037) Piston ring compressor	Installing piston assembly into cylinder bore	D E
KV10111100 (J37228) Seal cutter	Removing oil pan	F G H
WS39930000 (—) Tube presser	Pressing the tube of liquid gasket	I J
KV10112100 (BT-8653-A) Angle wrench	Tightening bolts for bearing cap, cylinder head, etc. in angle.	K L
ST16610001 (J23907) Pilot bushing puller	Removing pilot bushing	M
KV1017100 (J36471-A) Front (heated) oxygen sensor wrench	Loosening or tightening heated oxygen sensor with 22 m (0.87 in) hexagon nut	

PREPARATION

[QG18DE]

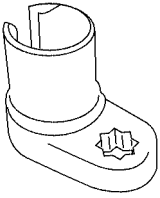
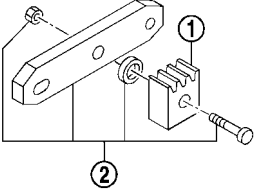
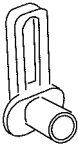
Tool number (Kent-Moore No.) Tool name		Description
(J44626) Air fuel ratio (A/F) sensor wrench	 <small>LEM054</small>	Loosening or tightening air fuel ratio (A/F) sensor 1
KV101056S0 (—) Rear gear stopper 1. KV10105620 (—) Adapter 2. KV10105610 (—) Plate assembly	 <small>NT773</small>	Preventing crankshaft from rotating
J-45488 Quick connector release	 <small>PBIC0198E</small>	Removing fuel tube quick connectors in engine room

Commercial Service Tools

EBS00CE9

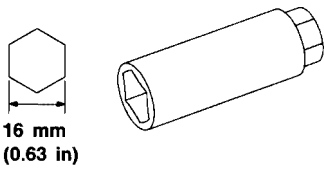
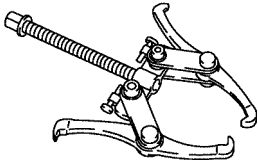
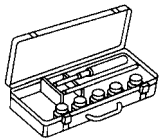
Tool name Kent-Moore No.		Description
Spark plug wrench	 <small>NT047</small>	Removing and installing spark plug
Crankshaft pulley puller	 <small>PBIC0887E</small>	Removing crankshaft pulley
Valve seat cutter set	 <small>NT048</small>	Finishing valve seat dimensions

PREPARATION

[QG18DE]

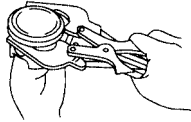
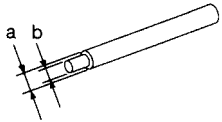
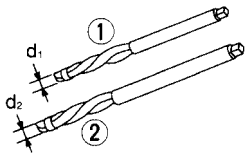
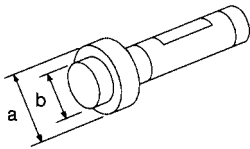
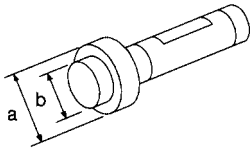
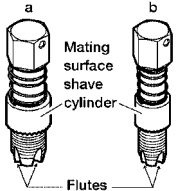
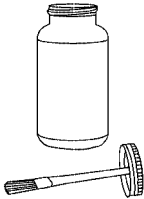
Tool name Kent-Moore No.	Description	
Piston ring expander  NT030	Removing and installing piston ring	A EM C
Valve guide drift  NT015	Removing and installing valve guide Intake & Exhaust: a: 9.5 mm (0.374 in) dia. b: 5.5 mm (0.217 in) dia.	D E
Valve guide reamer  NT016	Reaming valve guide 1 or hole for oversize valve guide 2 Intake & Exhaust: d1 : 5.5 mm (0.217 in) dia. d2 : 9.685 mm (0.3813 in) dia.	F G
Front oil seal drift  NT049	Installing front oil seal a: 52 mm (2.05 in) dia. b: 40 mm (1.57 in) dia.	H I
Rear oil seal drift  NT049	Installing rear oil seal a: 103 mm (4.06 in) dia. b: 84 mm (3.31 in) dia.	J K L
Oxygen sensor thread cleaner J-43897-18 J-43897-12  AEM488	Reconditioning the exhaust system threads before installing a new oxygen sensor (Use with anti-seize lubricant shown below.) a: J-43897-18 [18 mm dia.] for zirconium oxygen sensor b: J-43897-12 [12 mm dia.] for titania oxygen sensor	M
Anti-seize lubricant (Permatex 133AR or equivalent meeting MIL specification MIL-A-907)  AEM489	Lubricating oxygen sensor thread cleaning tool when reconditioning exhaust system threads	

NOISE, VIBRATION, AND HARSHNESS (NVH) TROUBLESHOOTING

[QG18DE]

NOISE, VIBRATION, AND HARSHNESS (NVH) TROUBLESHOOTING

PFP:00003

Noise, Vibration and Harshness (NVH) Troubleshooting NVH TROUBLESHOOTING — ENGINE NOISE

EBS00CEA

Use the chart below to help you find the cause of the symptom.

1. Locate the area where noise occurs.
2. Confirm the type of noise.
3. Specify the operating condition of engine.
4. Check specified noise source.

If necessary, repair or replace these parts.

Location of noise	Type of noise	Operating condition of engine						Source of noise	Check item	Reference page
		Before warm-up	After warm-up	When starting	When idling	When racing	While driving			
Top of Engine Rocker Cover Cylinder Head	Ticking or click	C	A	—	A	B	—	Tappet noise	Valve clearance	EM-35
	Rattle	C	A	—	A	B	C	Camshaft bearing noise	Camshaft journal clearance Camshaft runout	EM-33 , EM-34
Crankshaft Pulley Cylinder Block (Side of Engine) Oil pan	Slap or knock	—	A	—	B	B	—	Piston pin noise	Piston and piston pin clearance Connecting rod bushing clearance	EM-69 , EM-76
	Slap or rap	A	—	—	B	B	A	Piston slap noise	Piston-to-bore clearance Piston ring side clearance Piston ring end gap Connecting rod bend and torsion	EM-69 , EM-70 , EM-70 , EM-70
	Knock	A	B	C	B	B	B	Connecting rod bearing noise	Connecting rod bearing clearance (Big end) Connecting rod bushing clearance (Small end)	EM-75 , EM-76
	Knock	A	B	—	A	B	C	Main bearing noise	Main bearing oil clearance Crankshaft runout	EM-73 , EM-72
Front of Engine Timing Chain Cover	Tapping or ticking	A	A	—	B	B	B	Timing chain and chain tensioner noise	Timing chain cracks and wear Timing chain tensioner operation	EM-45
Front of Engine	Squeak or fizzing	A	B	—	B	—	C	Drive belts (sticking or slipping)	Drive belts deflection	MA-16
	Creaking	A	B	A	B	A	B	Drive belts (slipping)	Idler pulley bearing operation	
	Squall or creak	A	B	—	B	A	B	Water pump noise	Water pump operation	CO-10

A: Closely related B: Related C: Sometimes related —: Not related

A

EM

C

D

E

F

G

H

I

J

K

L

M

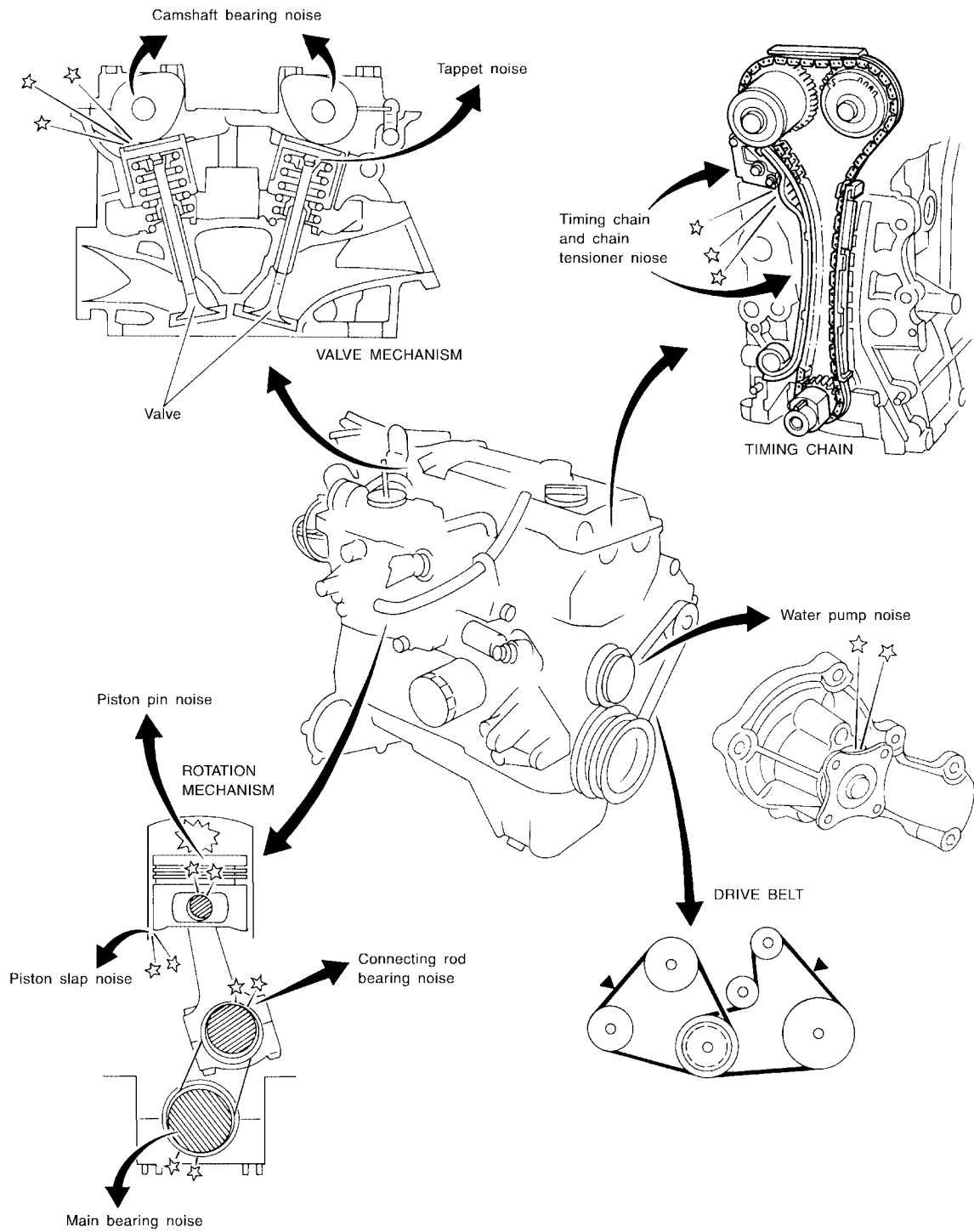

WBIA0061E

OUTER COMPONENT PARTS

[QG18DE]

- | | | | |
|------------------------|----------------------------------|----------------------|-------------------------|
| 1. Oil pressure switch | 4. Intake manifold upper support | 7. Thermostat | 10. Support container |
| 2. Air relief plug | 5. Intake manifold rear supports | 8. Water pump | 11. Transmission gusset |
| 3. Intake manifold | 6. Oil filter | 9. Water pump pulley | 12. Component bracket |

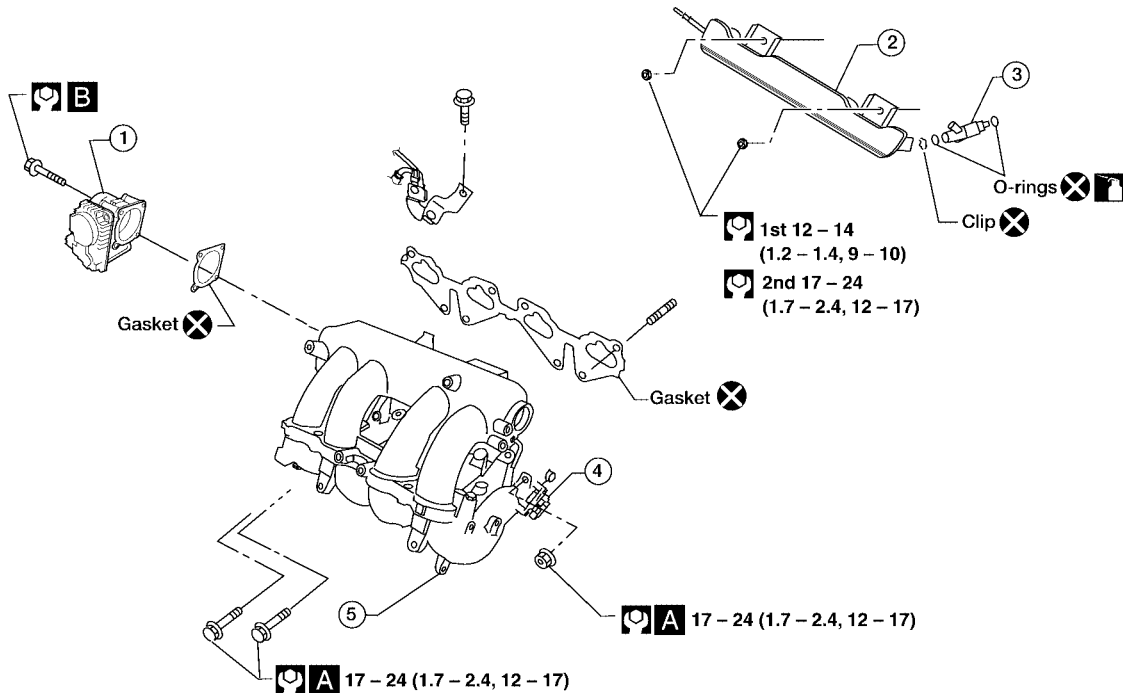

- : Lubricate with new engine oil
- : N·m (kg·m, in·lb)
- : N·m (kg·m, ft·lb)
- : Always replace after every disassembly.

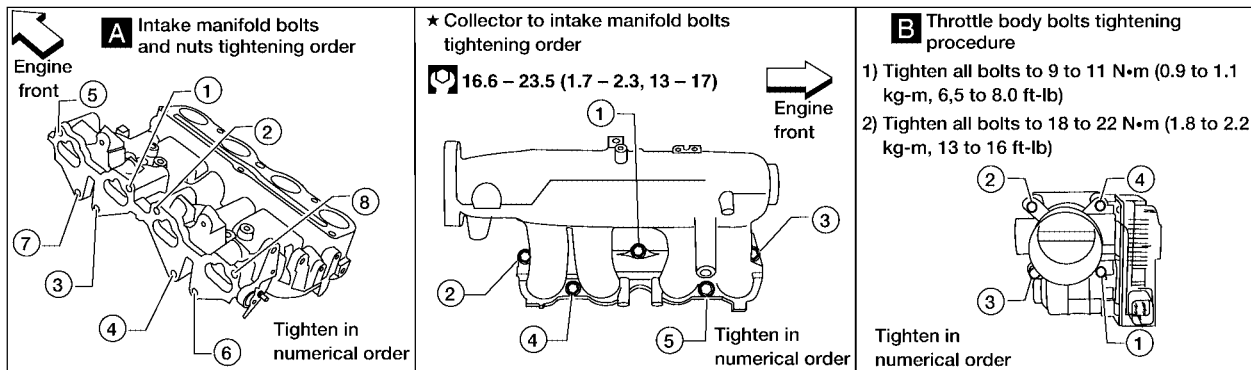

- | | | |
|---|--------------------|-------------|
| 1. Throttle body | 2. Fuel rail | 3. Injector |
| 4. Swirl control position sensor (SULEV only) | 5. Intake manifold | |

WBIA0113E

CAUTION:

- Perform "Throttle Valve Closed Position Learning" when harness connector of electronic throttle control actuator is disconnected. Refer to [EC-53, "Throttle Valve Closed Position Learning"](#) for QG18DE (ULEV) or [EC-634, "Throttle Valve Closed Position Learning"](#) for QG18DE (SULEV).

OUTER COMPONENT PARTS

[QG18DE]

- Perform "Idle Air Volume Learning" when harness connector of electronic throttle control actuator is replaced. Refer to [EC-53, "Idle Air Volume Learning"](#) for QG18DE (ULEV) or [EC-635, "Idle Air Volume Learning"](#) for QG18DE (SULEV).

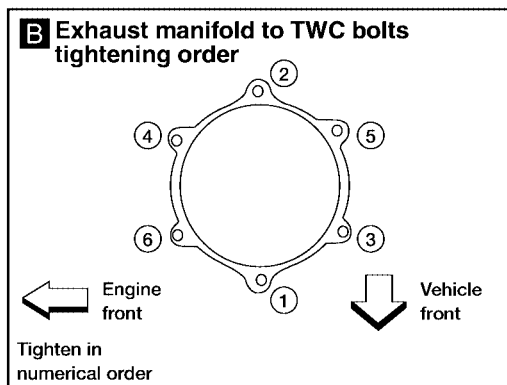
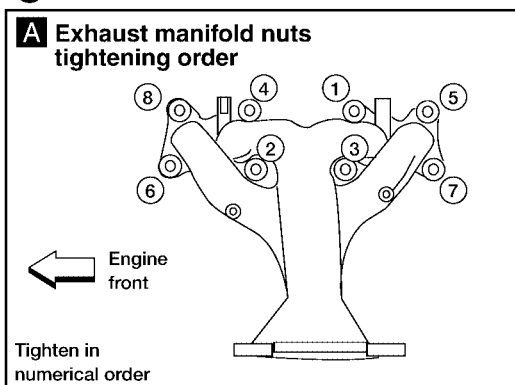
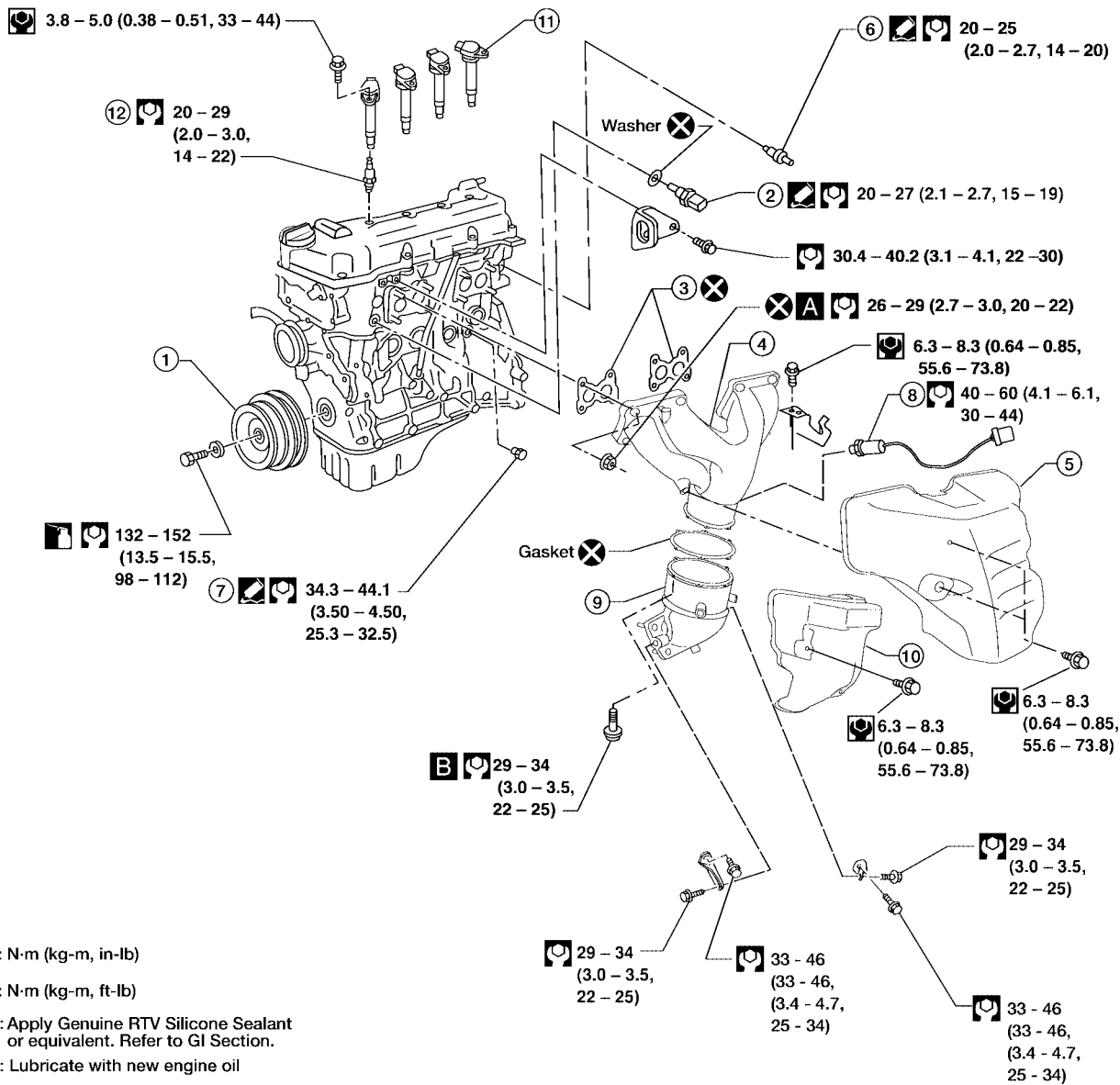

- | | | |
|----------------------|--------------------------------------|------------------------|
| 1. Crankshaft pulley | 2. Engine coolant temperature sensor | 3. Gasket |
| 4. Exhaust manifold | 5. Exhaust manifold cover | 6. Thermal transmitter |

WBIA0114E

OUTER COMPONENT PARTS

[QG18DE]

-
- | | | |
|---------------|---|-------------------|
| 7. Drain plug | 8. Heated oxygen sensor (ULEV)
Air fuel ratio (A/F) sensor (SULEV
only) | 9. TWC (manifold) |
| 10. TWC cover | 11. Ignition coil | 12. Spark plug |

A

EM

C

D

E

F

G

H

I

J

K

L

M

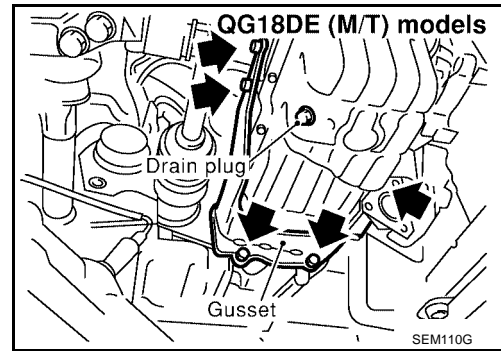

6. Remove rear plate cover (lower) (A/T models).
7. Remove oil pan.
 - a. Loosen and remove nuts and bolts of oil pan in order shown.

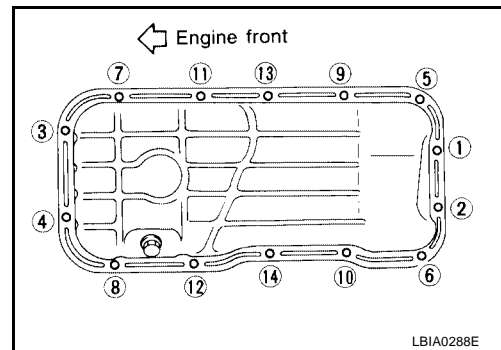

- b. Insert Tool between cylinder block and oil pan.

CAUTION:

 - Be careful not to damage aluminum mating face.
 - Do not insert screwdriver, or oil pan flange will be damaged.
- c. Slide Tool by tapping on the side of the Tool with a hammer.

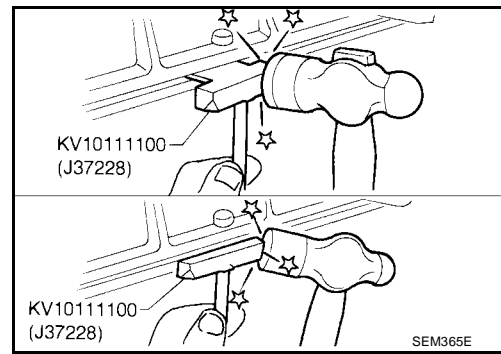

Installation

1. Use a scraper to remove old RTV Silicone Sealant from mating surface of oil pan.
 - Also remove old RTV Silicone Sealant from mating surface of cylinder block.

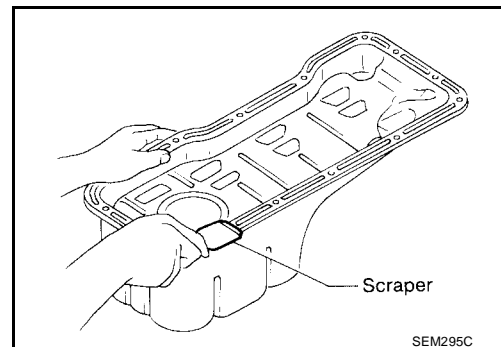

OIL PAN

[QG18DE]

2. Apply a continuous bead of RTV Silicone Sealant to mating surface of oil pan.
 - Use Genuine RTV Silicone Sealant or equivalent. Refer to [GI-44, "RECOMMENDED CHEMICAL PRODUCTS AND SEALANTS"](#).
 - Apply to groove on mating surface.
 - Allow 7 mm (0.28 in) clearance around bolt holes.

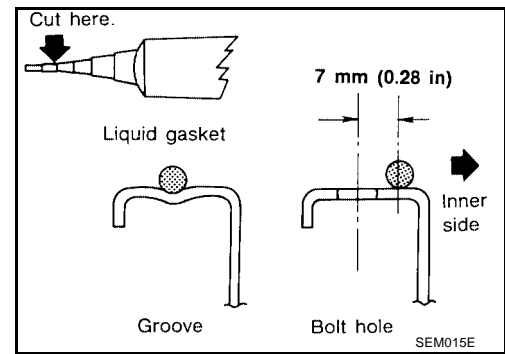

- Be sure RTV Silicone Sealant diameter is 3.5 to 4.5 mm (0.138 to 0.177 in).
- Installation should be done within 5 minutes after applying sealant.

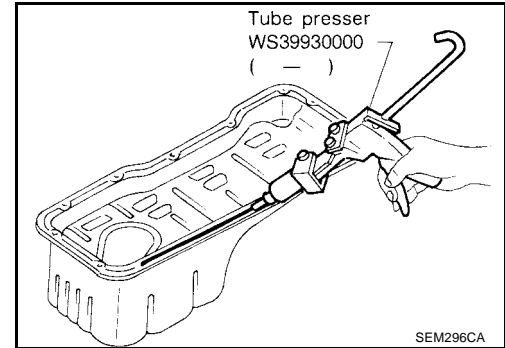

3. Install oil pan.
 - Tighten oil pan nuts and bolts in the numerical order.
 - Wait at least 30 minutes before refilling engine oil.
4. Install the remaining parts in the reverse order of removal.

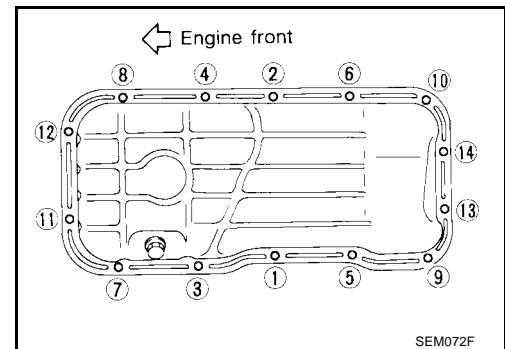

FUEL INJECTOR AND FUEL TUBE

Removal and Installation

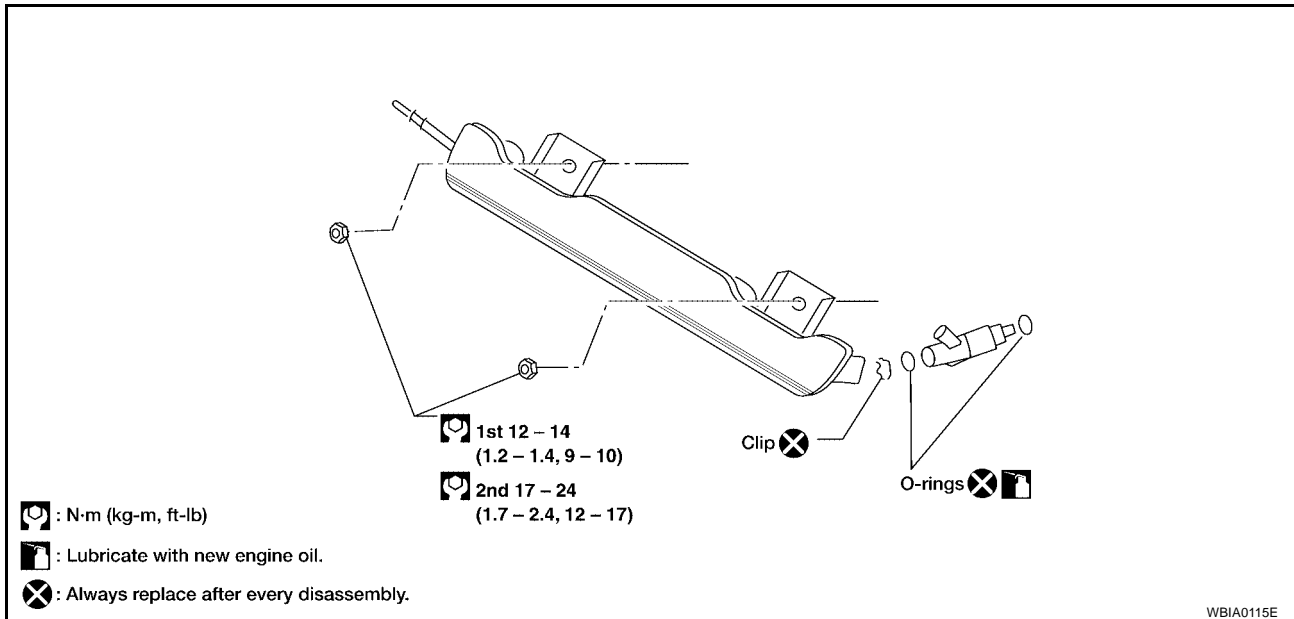

CAUTION:

- Apply new engine oil when installing the parts that specified to do so in the figure.
- Do not remove or disassemble parts unless instructed as shown above.

REMOVAL

1. Release the fuel pressure. Refer to [EC-56, "FUEL PRESSURE RELEASE"](#) (ULEV), [EC-637, "FUEL PRESSURE RELEASE"](#) (SULEV).
2. Disconnect the intake manifold bracket.
3. Remove the PCV hose and bracket.
4. Disconnect the sub-harness for the fuel injectors.
5. Disconnect the fuel quick connector on the engine side.
 - Using the quick connector release tool (hereinafter called "release tool"), perform the following steps to disconnect quick connector.

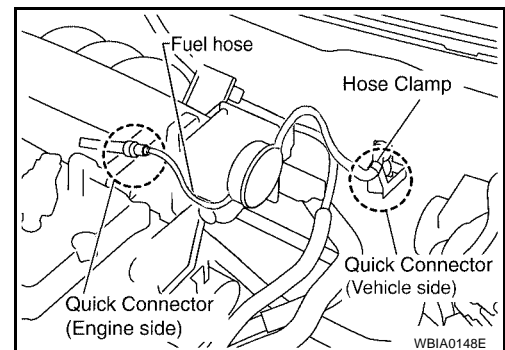

- a. Remove quick connector cap.

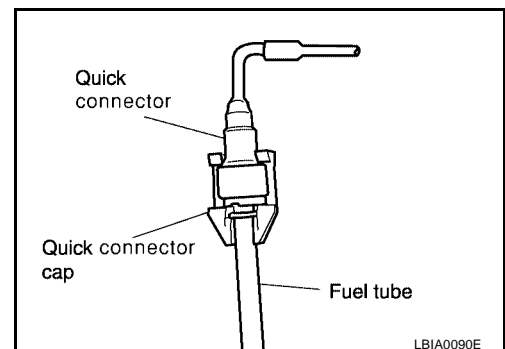

FUEL INJECTOR AND FUEL TUBE

[QG18DE]

- b. With the sleeve side of release facing quick connector, install release tool onto fuel tube.
- c. Insert release tool into quick connector until sleeve contacts and goes no further. Hold the release tool on that position.

CAUTION:

Inserting the release tool hard will not disconnect quick connector. Hold release tool where it contacts and goes no further.

- d. Pull the quick connector straight out from the fuel tube.

CAUTION:

- Pull quick connector holding it at the "A" position, as shown in illustration.
- Do not pull with lateral force applied. O-ring inside quick connector may be damaged.
- Prepare container and cloth beforehand as fuel will leak out.
- Avoid fire and sparks.
- Be sure to cover openings of disconnected pipes with plug or plastic bag to avoid fuel leakage and entry of foreign materials.

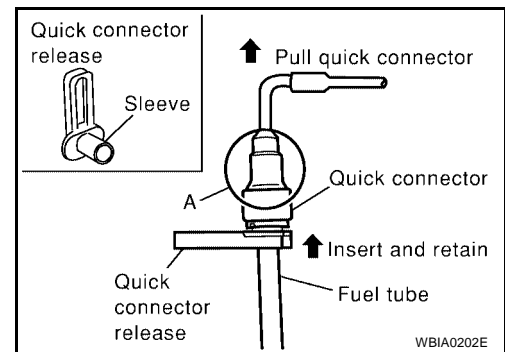

6. When removing fuel hose quick connector at vehicle piping side, perform as follows.

- a. Remove quick connector cap.
- b. Hold the sides of the connector, push in tabs and pull out the tube. (The figure is shown for reference only.)
 - If the connector and the tube are stuck together, push and pull several times until they start to move. Then disconnect them by pulling.

CAUTION:

- The tube can be removed when the tabs are completely depressed. Do not twist it more than necessary.
- Do not use any tools to remove the quick connector.
- Keep the resin tube away from heat. Be especially careful when welding near the tube.
- Prevent acid liquid such as battery electrolyte etc. from getting on the resin tube.
- Do not bend or twist the tube during installation and removal.
- Do not remove the remaining retainer on tube.
- When the tube is replaced, also replace the retainer with a new one. Retainer color: Green.
- To keep clean the connecting portion and to avoid damage and foreign materials, cover them completely with plastic bags or something similar.

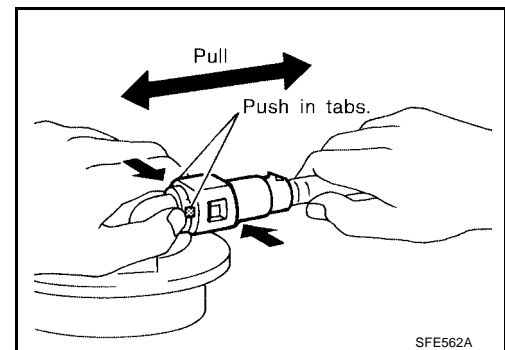

7. Remove the fuel injectors from the fuel tube, as follows:

- a. Release the clip, and remove the fuel injector.
- b. Pull the fuel injector straight out of the fuel tube.

CAUTION:

- Be careful not to damage the nozzle.
- Avoid any impact, such as dropping the fuel injector.
- Do not disassemble or adjust the fuel injector.

INSTALLATION

1. Installation is in the reverse order of removal.

- Install new O-rings on the fuel injectors.
- Lubricate the new O-rings lightly with new engine oil.
- Be careful not to scratch the injector during installation. Also be careful not to twist or stretch the O-ring. If the O-ring was stretched while it was installed, do not insert it into the fuel tube immediately.

FUEL INJECTOR AND FUEL TUBE

[QG18DE]

- a. Install the fuel injector into the fuel tube with the following procedure:
 - Do not reuse the clip, replace it with a new one.
 - Insert the clip into the clip mounting groove on the fuel injector.
 - Insert clip so that projection A of fuel injector matches notch A of the clip.
- b. Insert fuel injector into fuel tube with clip attached.
 - Insert it while matching it to the axial center.
 - Insert fuel injector so that projection B of fuel injector matches notch B of the clip.
 - Make sure that fuel tube flange is securely fixed in flange fixing groove on the clip.
 - Make sure that installation is complete by checking that fuel injector does not rotate or come off.
- c. Install the fuel tube assembly with the following procedure:
 - Insert the tip of each fuel injector into the intake manifold.

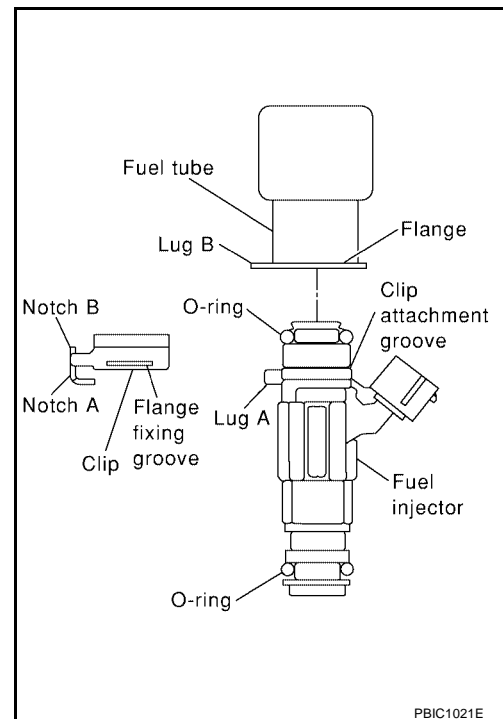

- Tighten the fuel tube mounting bolts in two stages in the numerical order shown.

Stage 1 : 12 - 14 N·m (1.2 - 1.4 kg·m, 9 - 10 ft·lb)

Stage 2 : 17 - 24 N·m (1.7 - 2.4 kg·m, 12 - 17 ft·lb)

CAUTION:

- After properly connecting fuel tube assembly to injector and fuel hose, check connection for fuel leakage.

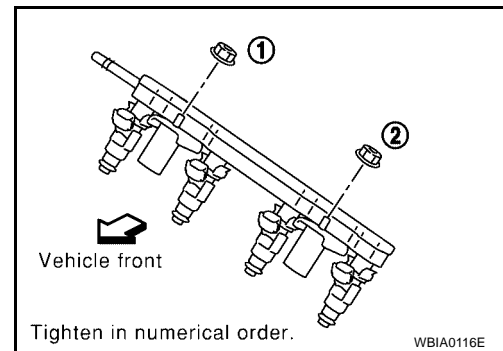

CONNECTING QUICK CONNECTOR ON THE FUEL HOSE (ENGINE SIDE)

1. Make sure no foreign substances are deposited in and around the fuel tube and quick connector, and there is no damage to them.
2. Thinly apply new engine oil around the fuel tube tip end.
3. Align center to insert quick connector straight into fuel tube.

- Insert fuel tube into quick connector until the top spool on fuel tubes is inserted completely and the second level spool is positioned slightly below the quick connector bottom end.

CAUTION:

- Hold at position "A" as shown, when inserting the fuel tube into the quick connector.
- Carefully align to center to avoid inclined insertion to prevent damage to the O-ring inside the quick connector.
- Insert the fuel tube until you hear a "click" sound and actually feel the engagement.
- To avoid misidentification of engagement with a similar sound, be sure to perform the next step.

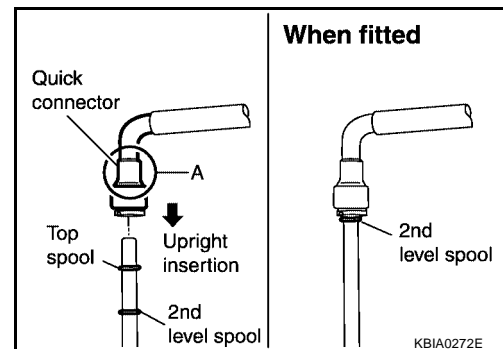

4. Before clamping the fuel hose with the hose clamp, pull the quick connector hard by hand, holding at the "A" position, as shown. Make sure it is completely engaged (connected) so that it does not come off of the fuel tube.

NOTE:

Recommended pulling force is 50 N (5.1 kg, 11.2 lb).

5. Install quick connector cap on quick connector joint.

FUEL INJECTOR AND FUEL TUBE

[QG18DE]

- Direct arrow mark on quick connector cap to upper side (fuel hose side).
6. Install fuel hose to hose clamp.

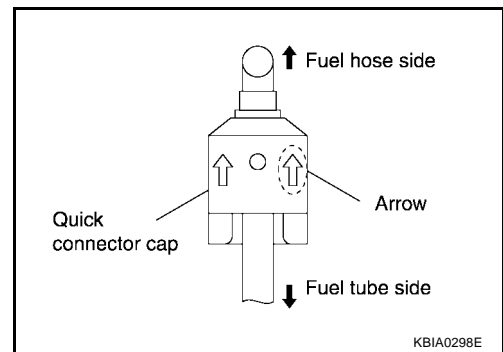

CONNECTING QUICK CONNECTOR ON THE FUEL HOSE (VEHICLE PIPING SIDE)

1. Make sure no foreign substances are deposited in and around the fuel tube and quick connector, and there is no damage to them.
2. Align center to insert quick connector straight into fuel tube.
 - Insert fuel tube until a click is heard.
 - Install quick connector cap on quick connector joint. Direct arrow mark on quick connector cap upper side.
 - Install fuel hose to hose clamp.

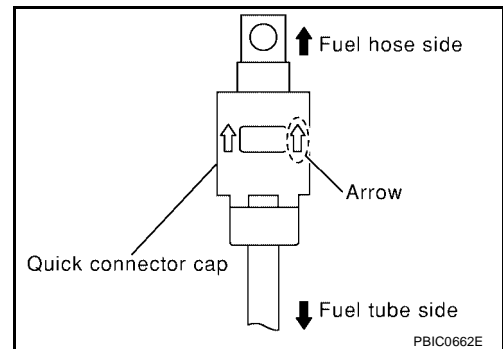

INSPECTION AFTER INSTALLATION

Make sure there is no fuel leakage at connections as follows:

1. Apply fuel pressure to fuel lines by turning ignition ON (with engine stopped). Then check for fuel leaks at connections.
2. Start the engine and rev it up and check for fuel leaks at connections.

NOTE:

Use mirrors for checking on hard to see points of the fuel system.

CAUTION:

Do not touch the engine immediately after stopping, as the engine becomes extremely hot.

ROCKER COVER

[QG18DE]

- Loosen the bolts in the numerical order as shown.
- If replacement is necessary, remove the rocker cover oil seal using a flat-head screwdriver.

CAUTION:

Be careful not to damage the rocker cover.

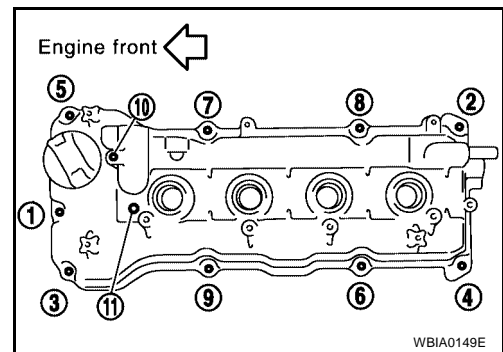

INSTALLATION

- Install the rocker cover oil seal.

- Using a drift with outer diameter 97 mm (3.82 in) and inner diameter 83 mm (3.27 in) to 88 mm (3.46 in), press in oil seal.

NOTE:

There are two types of oil seal. If oil seal with flat bottom surface is pressed in, drift with any inner diameter can be used.

- Press oil seal in until it is flush with installation surface.

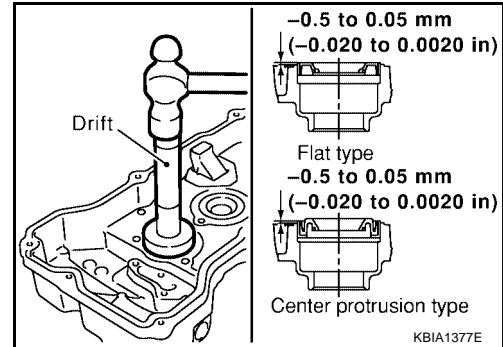

- Install the gasket on top of No. 1 camshaft bracket.
 - Position the gasket aligning its shape with camshaft bracket side. Align positioning stopper pin with hole gasket, and install.
- Install the gasket (for circumference, square type) to installation groove of rocker cover.

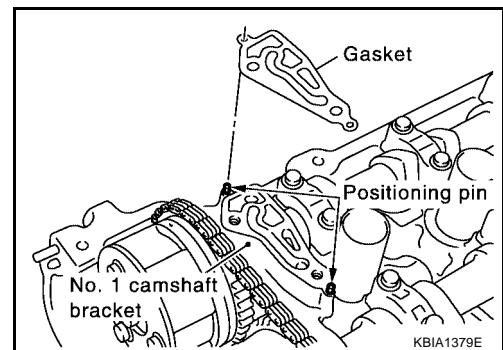

- Apply sealant to the positions shown, then install rocker cover.
 - Use Genuine RTV Silicone Sealant, or equivalent. Refer to [GI-44, "RECOMMENDED CHEMICAL PRODUCTS AND SEALANTS"](#).

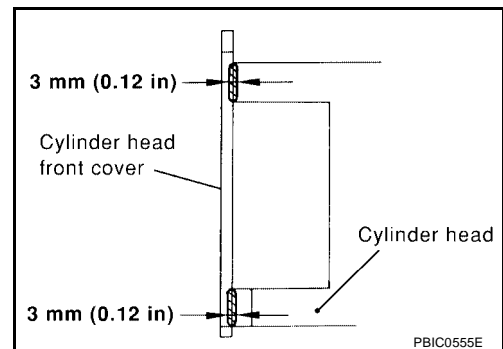

ROCKER COVER

[QG18DE]

5. Tighten the rocker cover bolts to specified torque in two steps, in the numerical order as shown.

Bolt length:	Bolt position	Torque
25 mm (0.98 in)	: 1	: 6.9 - 9.5 N·m (0.70 - 0.97 kg·m, 61 - 84 in·lb)
65 mm (2.56 in)	: 2	: 6.9 - 9.5 N·m (0.70 - 0.97 kg·m, 61 - 84 in·lb)
20 mm (0.79 in)	Except the above (all circumference)	: 6.9 - 9.5 N·m (0.70 - 0.97 kg·m, 61 - 84 in·lb)

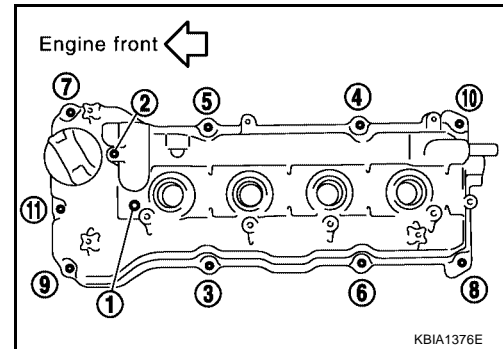

6. Install the intake valve timing control solenoid valve and camshaft position sensor (PHASE).
- Tighten bolts after fully inserting into rocker cover.

Intake valve timing control solenoid valve bolt	: 8.82 - 10.78 N·m (0.9 - 1.0 kg·m, 78 - 95 in·lb)
Camshaft position sensor (PHASE) bolt	: 7.2 - 10.8 N·m (0.73 - 1.1, 64 - 95 in·lb)

7. Install the PCV control valve.

PCV control valve	: 19.6 - 29.4 N·m (2.0 - 2.9 kg·m, 15 - 21 ft·lb)
-------------------	---

8. Install the remaining components in the reverse order of removal.

CAMSHAFT

Removal and Installation

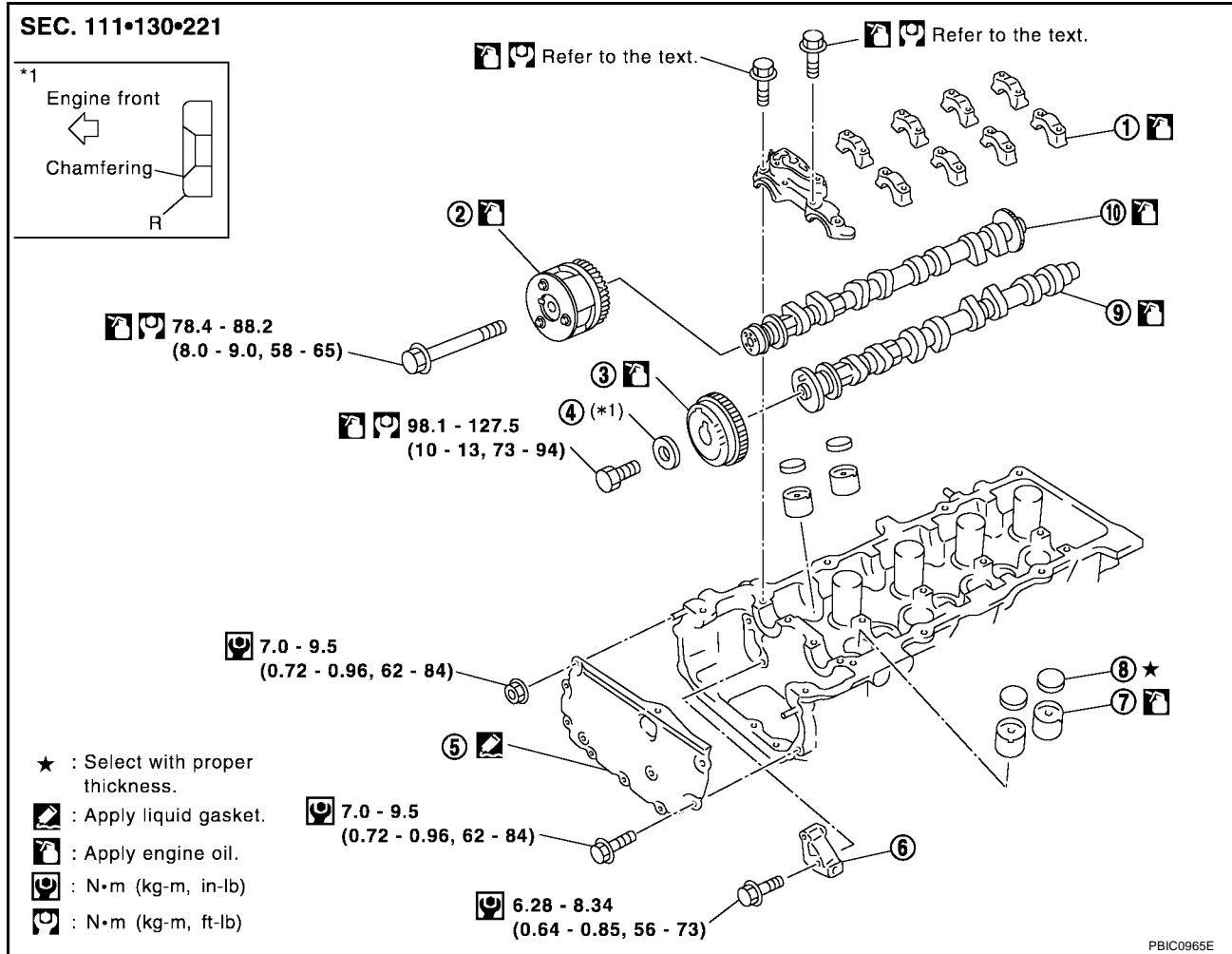

- | | | |
|----------------------|---------------------------------|----------------------------|
| 1. Camshaft brackets | 2. Camshaft sprocket (INT) | 3. Camshaft sprocket (EXH) |
| 4. Washer | 5. Cylinder head front cover | 6. Chain tensioner |
| 7. Valve lifter | 8. Adjusting shim (if equipped) | 9. Camshaft (EXH) |
| 10. Camshaft (INT) | | |

CAUTION:

Prior to installation, apply engine oil to the parts marked in the figure.

REMOVAL

1. Remove the rocker cover. Refer to [EM-23, "ROCKER COVER"](#).
2. Remove the cylinder head front cover.
 - Move harness secured to the front surface beforehand.
3. Set No. 1 cylinder at TDC of its compression stroke.
 - a. Remove the RH splash cover.
 - b. Rotate crankshaft pulley clockwise and align the yellow paint mark with the timing indicator.

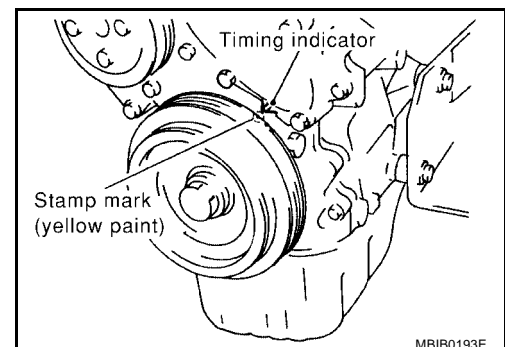

CAMSHAFT

[QG18DE]

- c. Confirm mating marks stamped on intake and exhaust sprockets are located as shown.
 - If not, rotate crankshaft pulley as shown and align them.
- d. Referring to mating marks on the intake and exhaust camshaft sprockets, put paint mating marks on timing chain links.

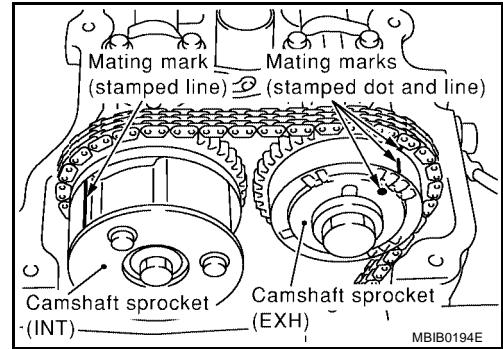

4. Set the intake camshaft sprocket to the most advanced position.

CAUTION:

Removal and installation of the intake camshaft sprocket is required to maintain the most advanced position because of the following reasons. Therefore, follow the procedure exactly.

- Sprocket and vane (camshaft in front) rotate and become offset within the specific angle range.
- When engine is stationary, the vane is located at the most retarded position. The vane is fixed to the sprocket by an internal lock pin. Therefore, it does not rotate.
- If the camshaft sprocket mounting bolts are turned under the above circumstance, the lock pin will be damaged by lateral load (shear stress). It may cause non-standard operation.

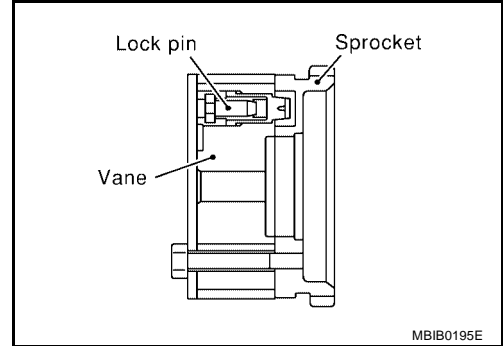

NOTE:

"Rotating direction" means direction viewed from the engine front side.

CAUTION:

Do not remove the chain tensioner before performing this step.

- a. Using a wrench, hold the hexagonal part so that the intake camshaft does not move.

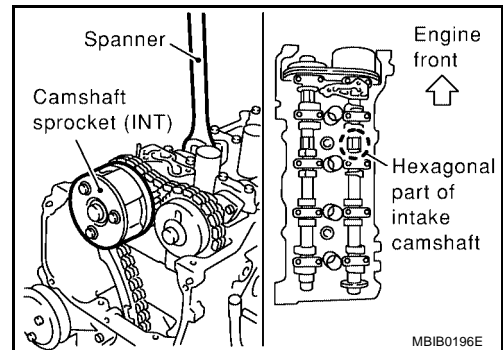

- b. Using an air gun, apply air pressure to the intake valve timing control solenoid valve advance side oil passage on the top surface of the No. 1 camshaft bracket.

Compressed air pressure : 300 kPa (3.06 kg/cm², 43.5 psi) or more

- Keep applying air pressure until step "d" is completed.

CAUTION:

- Be careful not to damage the oil passage from interference of the air gun tip.
- Thoroughly wipe off the oil before applying air pressure. When applying air pressure, cover around the air gun using a rag. Wear protective glasses if necessary.

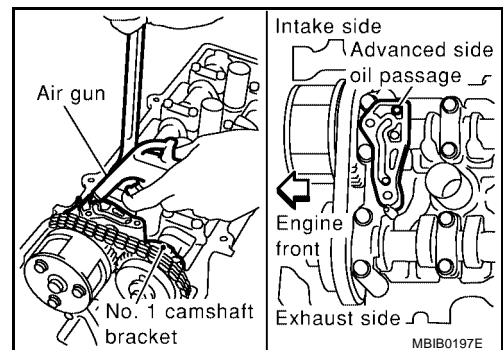

A
EM
C
D
E
F
G
H
I
J
K
L
M

CAMSHAFT

[QG18DE]

- c. Slowly turn the intake camshaft in direction A (counterclockwise: intake manifold side).
 ● Perform while applying air pressure.

CAUTION:

Be careful not to dislocate the camshaft retaining spanner.

- d. During the above step, an operating click (a sound indicating internal lock pin is disengaged) is heard from the inside of the intake camshaft sprocket. After hearing it, slowly turn intake camshaft in direction B (clockwise: exhaust manifold side), and set to most advanced position.

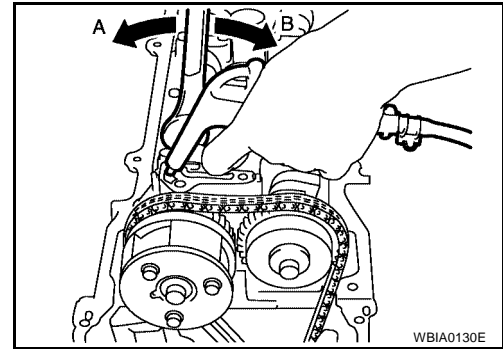

- Perform while applying air pressure.
- When the vane rotates solely against sprocket, lock pin is disengaged even if operating click is not heard.
- If the lock pin is not disengaged, jiggle the camshaft with a wrench.
- If the lock pin is not disengaged with the above step, tap the intake camshaft in front with a plastic hammer.

- e. The following status indicates that the most advanced position is achieved: vane starts rotating on its own, then the sprocket also starts rotating when camshaft is turned. When above status is achieved, this step is complete.

- The most advanced position is confirmed when the stopper pin groove and lock pin breathing groove are aligned.

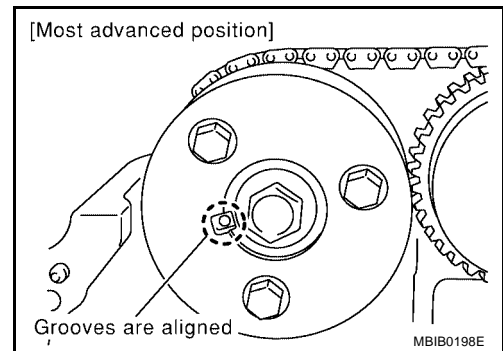

- f. Stop the air and insert stopper pin [approximately 3 mm (0.12 in) dia., length of inserted part is approximately 15 mm (0.59 in)] into pinhole on camshaft sprocket to fix the most advanced position.

NOTE:

In the figure, an Allen wrench [a/f 2.5 mm (0.091 in), short part: approximately 20 mm (0.79 in), long part: approximately 50 mm (1.97 in)] is used for stopper pin as an example.

CAUTION:

Load (spring reaction force) is not applied to stopper pin. Pin is easily detached. Therefore, secure it with vinyl tape to prevent detachment.

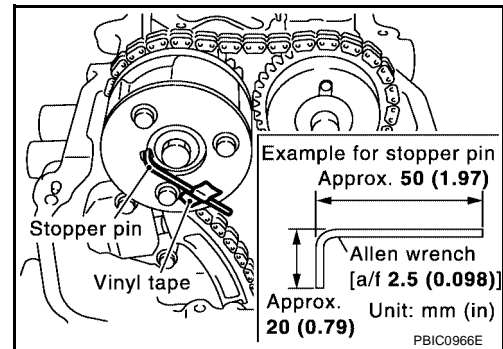

5. Remove the chain tensioner.

- Press the plate down and release the stopper tab.
- Insert the plunger into the tensioner body until it stops.
- Secure the plate by passing the stopper pin (such as a hard wire) through the plate hole and body hole. (Plunger is also secured.)
- Remove the mounting bolts and remove the chain tensioner.

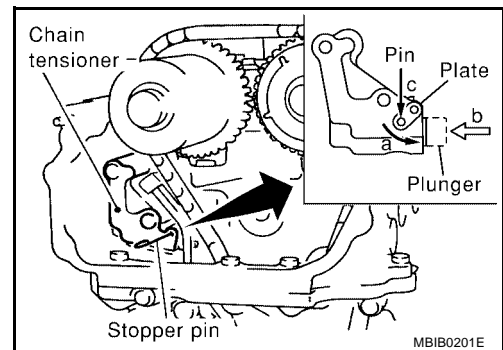

CAMSHAFT

[QG18DE]

6. While holding the hexagonal part of the camshaft with a wrench, loosen the mounting bolts and remove the intake and exhaust camshaft sprockets.

CAUTION:

- Avoid securing the camshaft at other than the hexagonal part and loosening mounting bolts by utilizing tension of timing chain.
- After this step is completed, do not rotate crankshaft and camshaft separately in order to prevent interference between the valves and pistons.

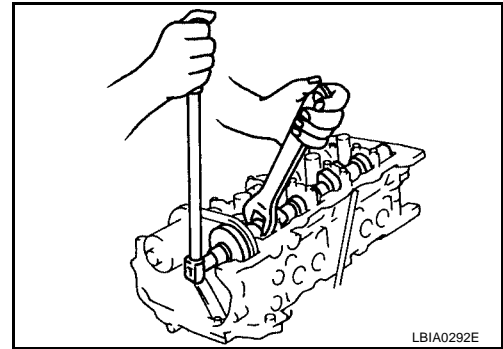

7. Handle the intake camshaft sprocket as follows.

CAUTION:

- Secure the stopper pin with vinyl tape to prevent detachment.
- Avoid dropping it or subjecting it to impact.
- Do not disassemble. (Do not loosen the 3 bolts on front surface.)

NOTE:

If stopper pin is detached and the lock pin is engaged at the most retarded position during removal, recover as follows.

- a. Reinstall the stopper pin to intake camshaft, and tighten the intake camshaft sprocket mounting bolts so that air does not leak.

CAUTION:

Tightening torque for the mounting bolts must be minimum so that air does not leak, preventing damage to the internal lock pin.

- b. Apply air pressure to disengage the lock pin, and turn the vane to the most advanced position. (This step can be performed with the timing chain removed.)
- c. Reinstall stopper pin.
- d. Remove intake camshaft sprocket from the camshaft.

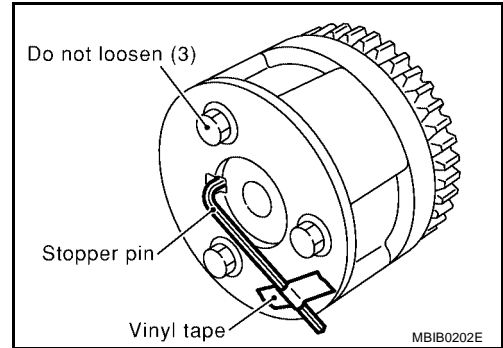

8. Loosen the camshaft bracket bolts in the order shown, and remove the camshaft brackets and camshafts.

CAUTION:

Be careful not to damage signal plate on rear end of intake camshaft.

9. Remove adjusting shims and valve lifters.
- Check mounting positions, and set them aside in the order removed.

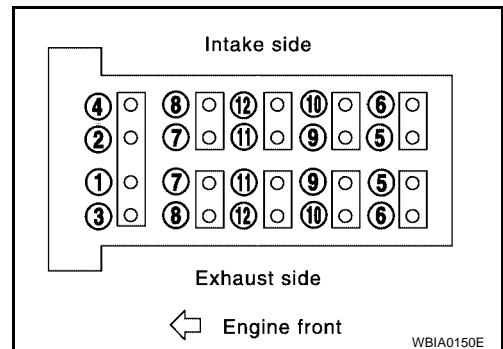

INSTALLATION

1. Install the valve lifter and adjusting shims.
- Install them in the same position from which they were removed.
 - Install adjusting shim with its stamped mark facing down (valve lifter side).

A
EM
C
D
E
F
G
H
I
J
K
L
M

CAMSHAFT

[QG18DE]

2. Install the camshafts.

- Intake and exhaust camshafts are distinguished by checking difference between front and rear end shapes.

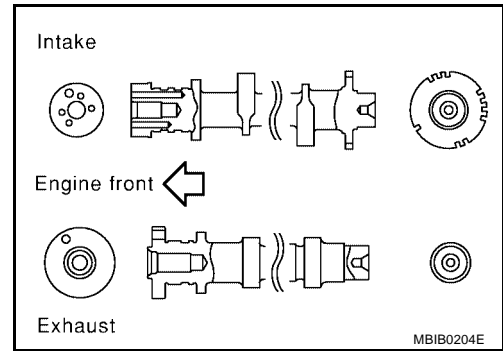

- Install camshafts so that the dowel pins on the front side are positioned as shown.

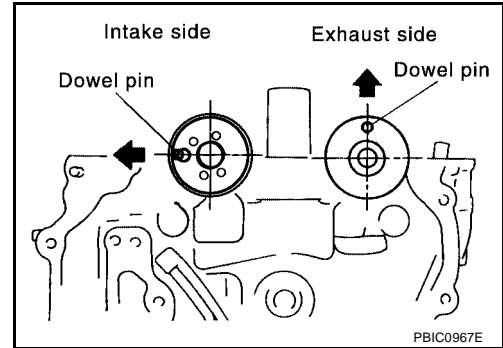

3. Install camshaft brackets.

- Completely remove any foreign material on mounting surfaces of camshaft brackets and mounting surface of cylinder head.
- Referring to marks on top surfaces of camshaft brackets, install them to their original positions and in their original directions.

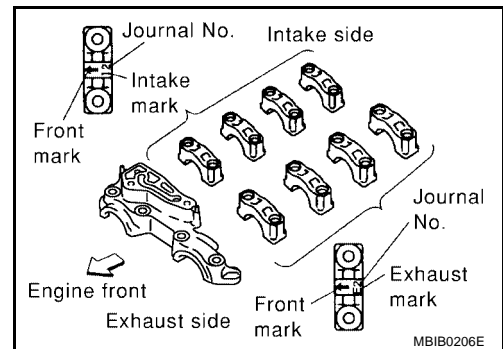

4. Tighten camshaft bracket mounting bolts as follows.

- Different bolts are used depending on installation location. Refer to following for proper bolt locations.

Bolt color:

1 to 10 in figure : black (reamer bolt)

11 and 12 in figure : gold

Camshaft bracket bolt

Step 1 (bolts 9 - 12) : 2.0 N-m (0.2 kg-m, 18 in-lb)

Step 2 (bolts 1 - 8) : 2.0 N-m (0.2 kg-m, 18 in-lb)

Step 3 : 5.9 N-m (0.6 kg-m, 52 in-lb)

Step 4 : 9.0 - 11.8 N-m (0.92 - 1.2 kg-m, 80 - 104 in-lb)

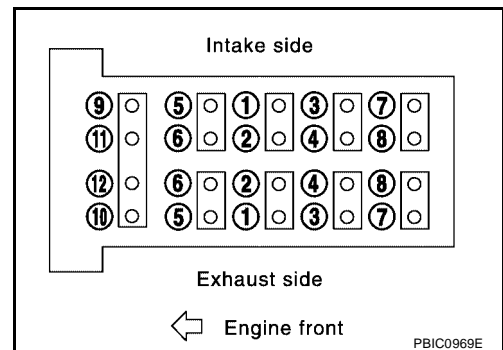

5. Install intake camshaft sprocket as follows.

- Before installation, make sure that stopper pin is inserted in intake camshaft sprocket.

NOTE:

Service parts are provided with pin inserted.

CAUTION:

Stopper pin is easily detached. Secure it with vinyl tape to prevent detachment.

- a. Install timing chain by aligning the mating mark (marked when timing chain is removed) with mark on camshaft sprocket.
 - Align dowel pin on camshaft front surface and pinhole on sprocket backside, then install.

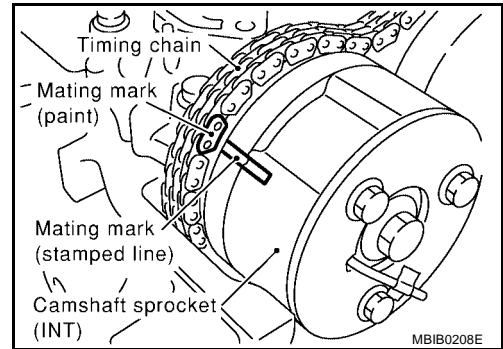

- b. While holding the hexagonal part of camshaft with a wrench, tighten intake camshaft sprocket bolt to specification.
 - Make sure that stopper pin is not detached.

Intake camshaft sprocket bolt : 78.4 - 88.2 N·m (8.0 - 9.0 kg·m, 58 - 65 ft·lb)

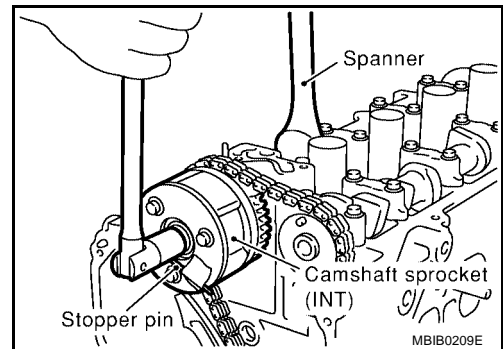

6. Install exhaust camshaft sprocket as follows.

- a. Install timing chain by aligning the mating mark (marked when timing chain is removed) with mark on camshaft sprocket.
 - Align dowel pin on camshaft front surface and pinhole on sprocket, then install.
- b. While holding the hexagonal part of the camshaft with a wrench, tighten exhaust camshaft sprocket bolt to specification.

Exhaust camshaft sprocket bolt : 98.1 - 127.5 N·m (10 - 13 kg·m, 73 - 94 ft·lb)

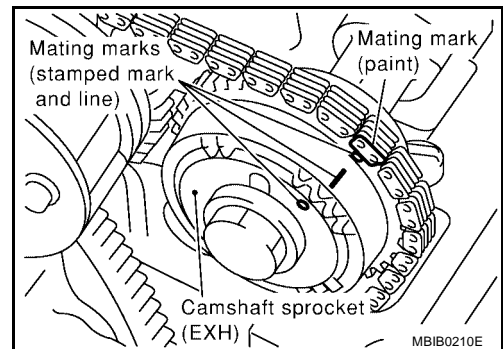

- c. Make sure that mating marks on intake/exhaust camshaft sprockets and mating mark on timing chain are aligned.

7. Install chain tensioner.

- Hold plate and plunger with a stopper pin, then install them.
- After installation, remove stopper pin and release plunger.
- Make sure again that mating marks on intake/exhaust camshaft sprockets and mating mark on timing chain are aligned.

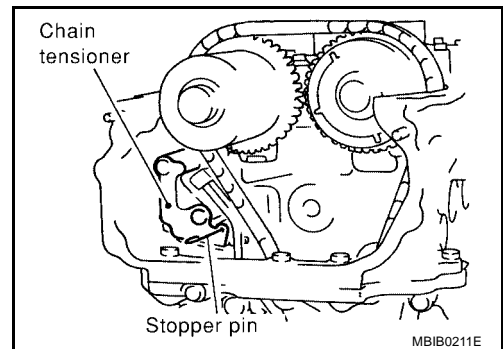

A
EM
C
D
E
F
G
H
I
J
K
L
M

8. Remove stopper pin from intake camshaft sprocket.

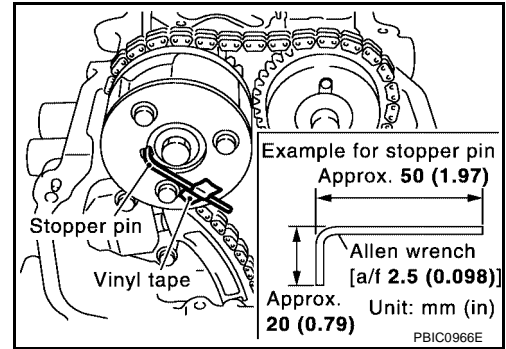

9. Slowly turn crankshaft pulley clockwise to set intake camshaft sprocket to most retarded position.

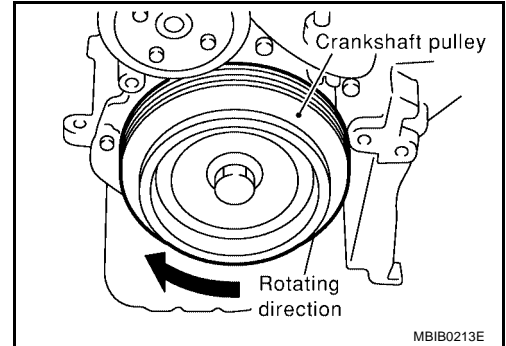

- The sprocket begins turning after the crankshaft does. Once sprocket starts turning, keep turning crankshaft until the vane (camshaft) also begins turning. The most retarded position should now be achieved.
- The most retarded position is confirmed when stopper pin groove is at a clockwise offset from lock pin breathing groove.
- While turning crankshaft slightly more counterclockwise, confirm that the lock pin is engaged when vane and sprocket turn together.

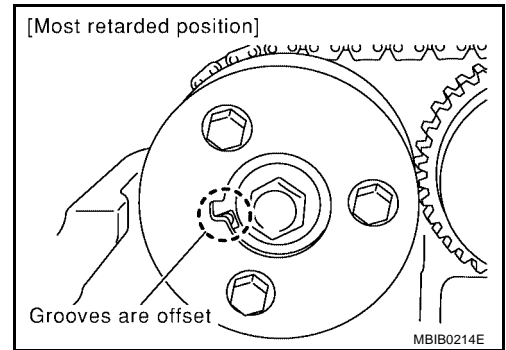

10. Install cylinder head front cover.

- Apply Genuine Anaerobic Liquid Gasket or equivalent as shown in the figure. Refer to [GI-44, "RECOMMENDED CHEMICAL PRODUCTS AND SEALANTS"](#).
- Install it by aligning the dowel pin on the cylinder head.

11. Check and adjust valve clearance. Refer to [EM-35, "Valve Clearance"](#).

12. Install the remaining components in the reverse order of removal.

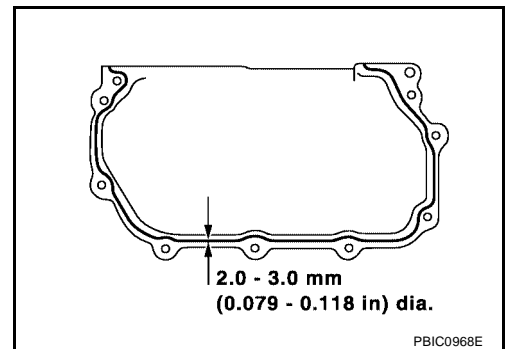

INSPECTION AFTER REMOVAL

Check camshaft for scratches, seizure and wear.

Camshaft Runout

1. Put the camshaft on a V-block supporting the No.2 and No.5 journals.
2. Set the dial gauge vertically on the No.3 journal.
3. Turn camshaft in one direction by hand, and measure the camshaft runout on the dial gauge total indicator reading.

Standard : Less than 0.02 mm (0.0008 in)
Limit : 0.1 mm (0.004 in)

4. If it exceeds the limit, replace camshaft.

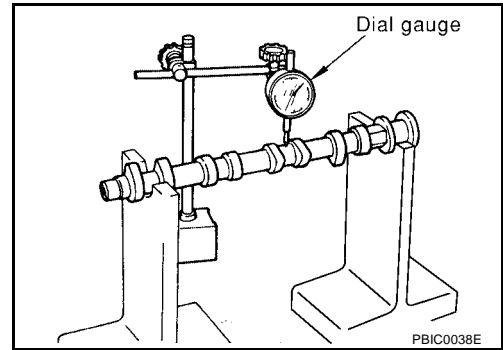

Camshaft Cam Height

1. Measure the camshaft cam height.

Standard intake cam height : 40.61 - 40.8 mm (1.599 - 1.606 in)

Standard exhaust cam height : 38.965 - 39.155 mm (1.534 - 1.542 in)

Cam wear limit : 0.20 mm (0.0079 in)

2. If wear is beyond the limit, replace the camshaft.

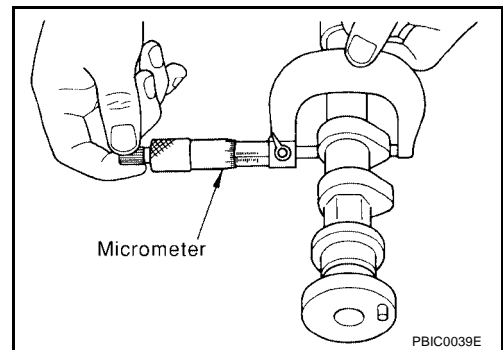

Camshaft Journal Clearance

1. Install the camshaft brackets and tighten the bolts to specified torque.
2. Using inside micrometer, measure inner diameter of camshaft bracket.

Standard No. 1 Intake and exhaust : 28.000 - 28.021 mm (1.1024 - 1.1032 in)

Standard No.2, 3, 4, 5 Intake : 23.985 - 24.006 mm (0.9443 - 0.9451 in)

Exhaust : 24.000 - 24.021 mm (0.9449 - 0.9457 in)

3. Measure the outer diameter of the camshaft journal.

Standard No.1 : 27.935 - 27.955 mm (1.0998 - 1.1006 in)

Standard No. 2, 3, 4, 5 : 23.935 - 23.955 mm (0.9423 - 0.9431 in)

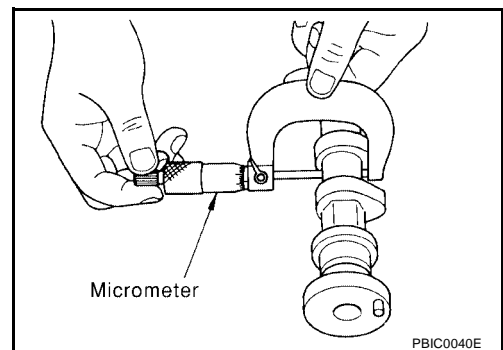
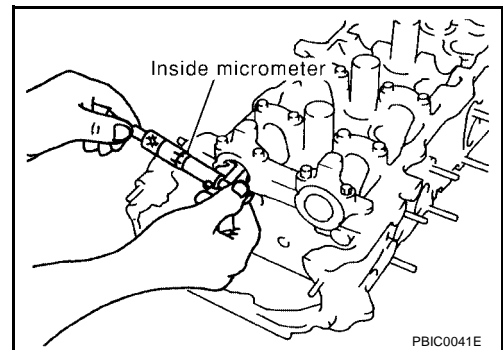

4. If the journal clearance exceeds the limit, replace camshaft and/or cylinder head.
 - (Camshaft journal clearance) = (inner diameter of camshaft bracket) – (outer diameter of camshaft journal)

Camshaft journal clearance

Standard

Intake : 0.030 - 0.071 mm (0.0012 - 0.0028 in)

Exhaust : 0.045 - 0.086 mm (0.0018 - 0.0034 in)

Limit

Intake : 0.135 mm (0.0053 in)

Exhaust : 0.150 mm (0.0059 in)

NOTE:

Inner diameter of the camshaft bracket is manufactured together with the cylinder head. If the camshaft bracket is out of specification, replace the entire cylinder head assembly.

Camshaft End Play

1. Install camshaft in cylinder head. Refer to [EM-29, "INSTALLATION"](#)
2. Install a dial gauge in the thrust direction on the front end of the camshaft. Measure the end play with the dial gauge while moving the camshaft forward and backward (in direction to axis).

Camshaft end play

Standard : 0.115 - 0.188 mm (0.0045 - 0.0074 in)

Limit : 0.20 mm (0.0079 in)

3. If out of the specified range, replace with new camshaft and measure again.
4. If out of the specified range again, replace with new cylinder head assembly.

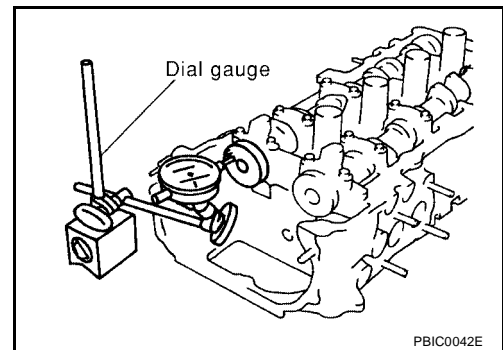

Camshaft Sprocket Runout

1. Install the camshaft sprocket on the camshaft.
2. Measure camshaft sprocket runout while turning the camshaft by hand.

Runout (total indicator reading) : Less than 0.15 mm (0.0059 in)

3. If it exceeds the specification, replace camshaft sprocket.

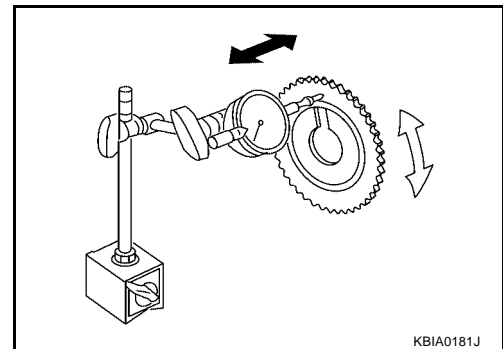

Valve Lifter and Valve Shim

1. Check contact and sliding surfaces for excessive wear or cracks, replace as necessary.

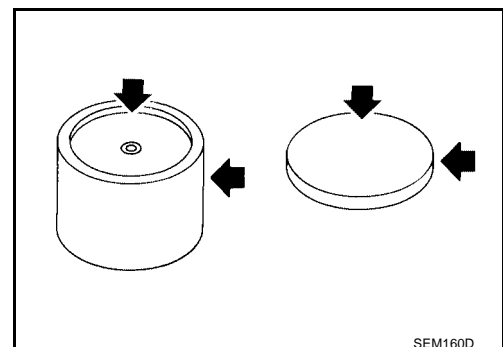

2. Measure the valve lifter outer diameter.

Valve lifter outer diameter : 29.960 - 29.975 mm (1.1795 - 1.1801 in)

If out of the specified range, replace the valve lifter.

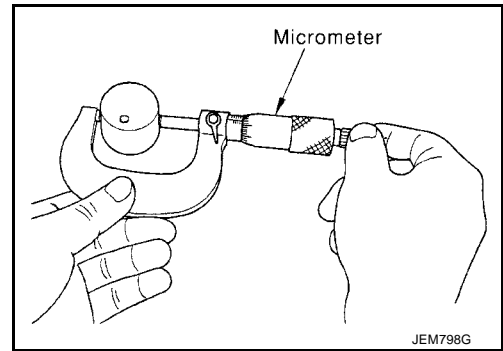

3. Measure the valve lifter guide bore.

Standard : 30.000 - 30.021 mm (1.1811 - 1.1819 in)

4. Calculate valve lifter clearance. If out of specified range, replace valve lifter and/or cylinder head of whichever exceeds standard limit.
 (Valve lifter clearance) = (valve lifter guide bore) – (outer diameter of valve lifter)

Valve lifter clearance : 0.025 - 0.065 mm (0.0010 - 0.0026 in)

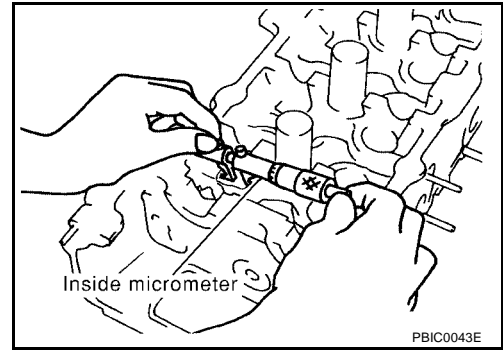

Valve Clearance INSPECTION

NOTE:

The following procedure is applicable when: components related to camshafts or valves are removed, installed, or replaced. Driveability concerns (poor starting, poor idling, noise) are caused by valve clearance aging.

1. Warm engine and stop.
2. Remove RH splash cover.
3. Remove the rocker cover. Refer to [EM-23, "ROCKER COVER"](#).
4. Remove all of the spark plugs.
5. Set No. 1 cylinder at TDC on its compression stroke.
 - Align pointer with TDC mark on crankshaft pulley.
 - Check that both intake and exhaust cam noses on No. 1 cylinder face outward.
 - If not, turn crankshaft one revolution (360°) and align as described above.

NOTE:

Or, valves to be checked when No. 4 cylinder is at TDC of its compression stroke can be checked first following step 8.

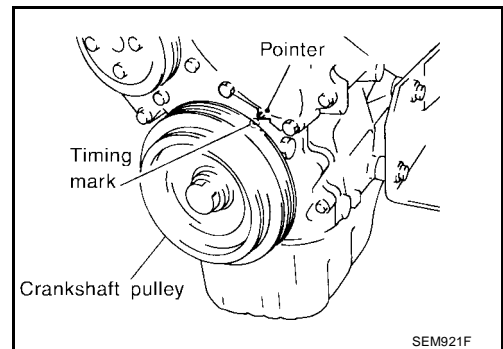

6. Referring to figure, measure valve clearances of valves with x in table below using a thickness gauge.

Cylinder	No. 1		No. 2		No. 3		No. 4	
	INT	EXH	INT	EXH	INT	EXH	INT	EXH
No. 1 cylinder at TDC of its compression stroke	X	X	X			X		

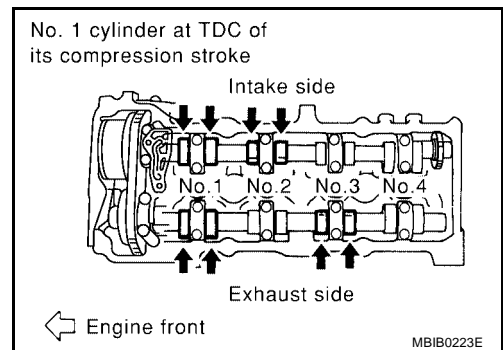

CAMSHAFT

[QG18DE]

- Using a feeler gauge, measure clearance between valve lifter and camshaft.
- Record any valve clearance measurements which are out of specification. They will be used later to determine the required replacement adjusting shim.

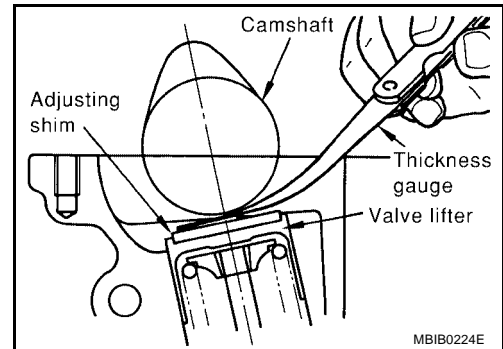

Valve clearance standard:		
Hot	Intake	: 0.32 - 0.40 mm (0.013 - 0.016 in)
	Exhaust	: 0.37 - 0.45 mm (0.015 - 0.018 in)
Cold*	Intake	: 0.25 - 0.33 mm (0.010 - 0.013 in)
	Exhaust	: 0.32 - 0.40 mm (0.013 - 0.016 in)

*: Approximately 20°C (68°F) (Reference data)

If an adjustment is done with a cold engine, confirm reference values with hot engine are met.

Limit values with hot engine (reference)	Intake	: 0.21 - 0.47 mm (0.008 - 0.019 in)
	Exhaust	: 0.30 - 0.56 mm (0.012 - 0.022 in)

- Turn crankshaft one revolution (360°) to position No. 4 cylinder at TDC of its compression stroke.
- Check only those valves shown in the figure and marked with an x in the table.

Cylinder	No. 1		No. 2		No. 3		No. 4	
	INT	EXH	INT	EXH	INT	EXH	INT	EXH
No. 4 cylinder at TDC of its compression stroke				X	X		X	X

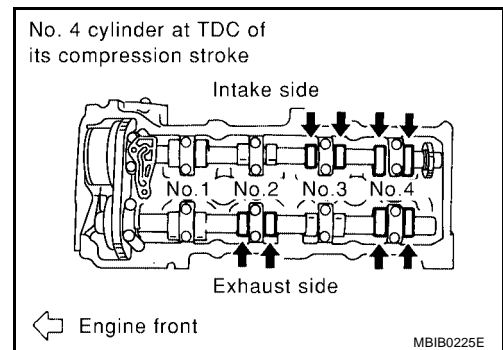

- If outside the standard, adjust applicable valves. Refer to [EM-36, "ADJUSTING"](#).

ADJUSTING

Adjust valve clearance while engine is cold.

- Turn crankshaft clockwise (viewed from front) to position cam lobe upward on camshaft for valve that must be adjusted.
- Turn valve lifter and adjusting shim to removal direction.
 - Using a slotted screwdriver with an extra-thin tip, turn the valve lifter cutout in the direction shown by the arrow.

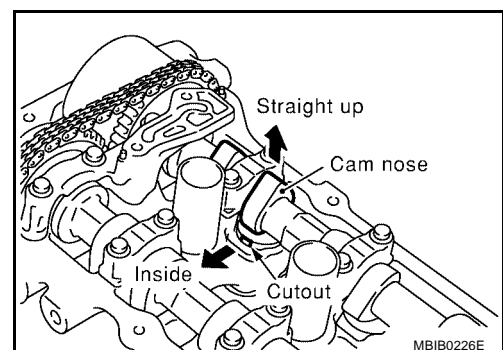

CAMSHAFT

[QG18DE]

3. Place Tool (1) around camshaft as shown. Before placing Tool (1), rotate notch toward center of cylinder head. This will simplify shim removal later.

CAUTION:

- Be careful not to damage camshaft and cylinder head.
- Be careful not to damage surroundings of valve lifter.

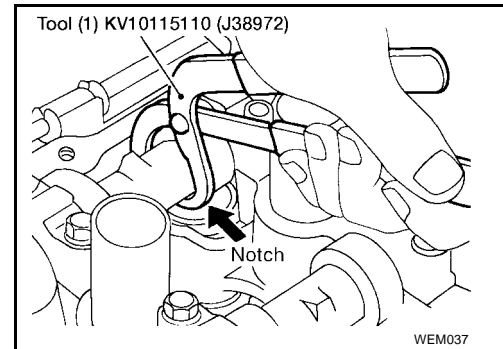

4. Rotate Tool (1) so that valve lifter is pushed down, compressing the spring.

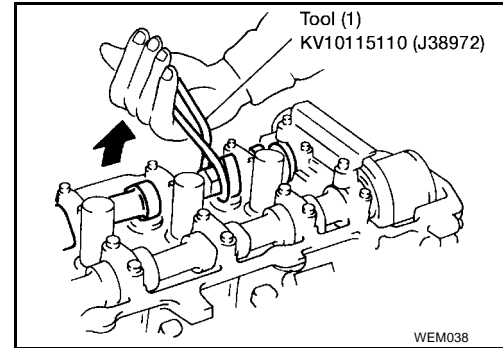

5. Place Tool (2) between camshaft and valve lifter to retain valve lifter.

CAUTION:

- If camshaft pliers are suddenly turned back, the lifter stopper may contact and damage the camshaft journals. Turn back the camshaft pliers carefully to remove.
- Tool (2) must be placed as close to camshaft bracket as possible.
- Be careful not to damage cam surface with Tool (2).

6. Remove Tool (1).

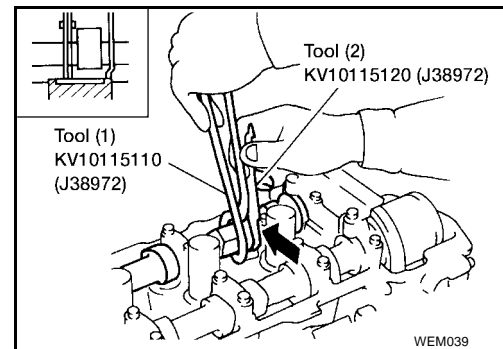

7. Keep adjusting shim slightly up from the valve lifter. Remove adjusting shim using Tool and a magnetic finger.

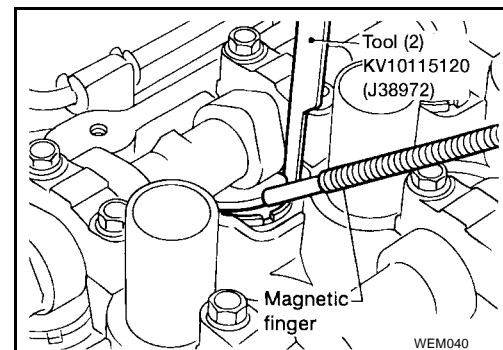

A
EM
C
D
E
F
G
H
I
J
K
L
M

8. Determine replacement adjusting shim size using the following formula.

- Use a micrometer to determine thickness (t1) of removed shim at camshaft contact face (around center).
- Use $t1 + (C1 - C2)$ to calculate thickness of new adjusting shim so valve clearance comes within specified values.

t1 = Thickness of removed shim
 C1 = Measured valve clearance
 C2 = Standard valve clearance

Hot engine:

Intake : 0.32 - 0.40 mm (0.013 - 0.016 in)

Exhaust : 0.37 - 0.45 mm (0.015 - 0.018 in)

Reference values with cold engine:

Intake : 0.25 - 0.33 mm (0.010 - 0.013 in)

Exhaust : 0.32 - 0.40 mm (0.013 - 0.016 in)

- Thickness of new adjusting shim is indicated with stamped mark on its back.
- **Shims are available in 50 sizes from 2.00 mm (0.0787 in) to 2.98 mm (0.1173 in), in steps of 0.02 mm (0.0008 in).**
- Select the closest size shim to the calculated thickness. Refer to [EM-83, "Available Shims"](#).

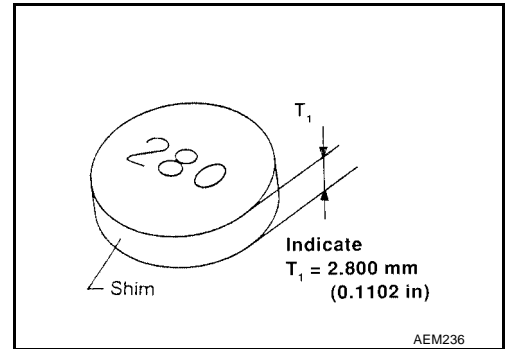
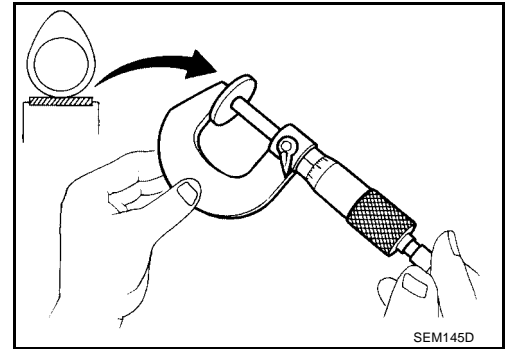

9. Install new shim using a suitable tool.

- **Install with the surface on which the thickness is stamped facing down.**

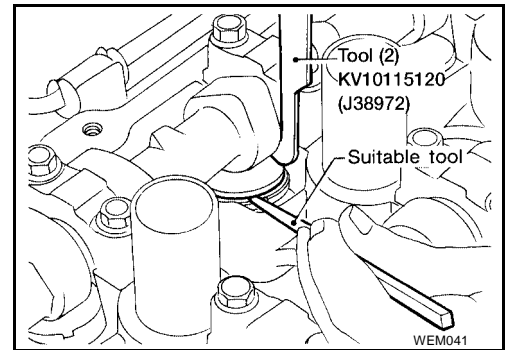

10. Place Tool (1) as explained in steps 4 and 5.

11. Remove Tool (2).

12. Remove Tool (1).

13. Turn the crankshaft a couple of times by hand.

14. Recheck the valve clearance.

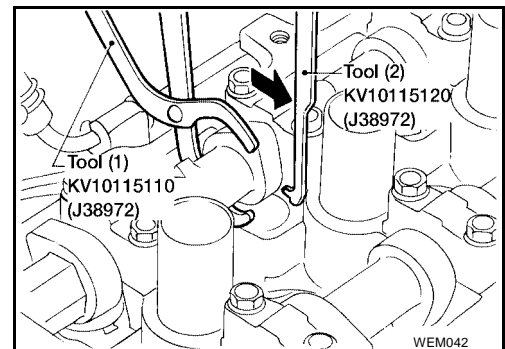

TIMING CHAIN

[QG18DE]

PF1:13028

EBS00CEH

TIMING CHAIN

Components

SEC. 120•130•135•493

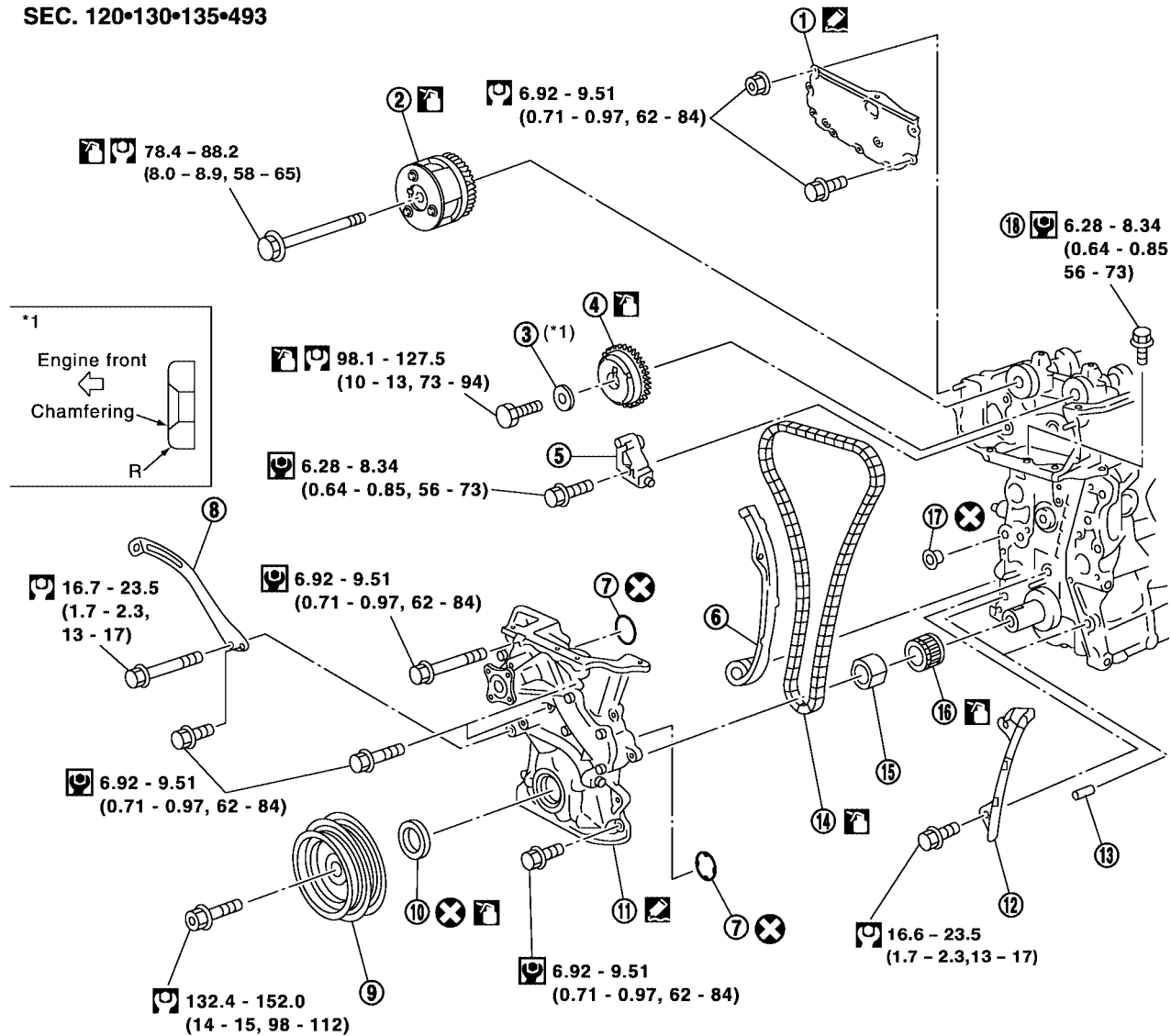

- ⊗ : Always replace after every disassembly.
- 🔧 : Lubricate with new engine oil.
- 🔩 : Apply Genuine RTV Silicone Sealant or equivalent. Refer to GI Section.
- 🔩 : N•m (kg-m, ft-lb)
- 🔩 : N•m (kg-m, in-lb)

- | | | |
|------------------------------|--------------------------------------|-------------------------------------|
| 1. Cylinder head front cover | 2. Camshaft sprocket (INT) | 3. Washer |
| 4. Camshaft sprocket (EXH) | 5. Chain tensioner | 6. Chain slack guide |
| 7. O-ring | 8. Power steering pump adjusting bar | 9. Crankshaft pulley |
| 10. Front oil seal | 11. Front cover | 12. Chain tensioner guide |
| 13. Dowel pin | 14. Timing chain | 15. Oil pump drive spacer |
| 16. Crankshaft sprocket | 17. O-ring (with collar) | 18. Auxiliary bolt of cylinder head |

CAUTION:

- After removing timing chain, do not turn crankshaft and camshaft separately, or valves will strike piston heads.
- When installing chain tensioner, oil seals, or other sliding parts, lubricate contacting surfaces with new engine oil.

TIMING CHAIN

[QG18DE]

- Apply new engine oil to bolt threads and seat surfaces when installing camshaft sprocket and crankshaft pulley.

Removal

EBS00CEI

1. Disconnect battery ground cable.
2. Drain engine coolant. Refer to [MA-16, "DRAINING ENGINE COOLANT"](#) .
Be careful not to spill coolant on drive belts.
3. Drain engine oil. Refer to [MA-20, "Changing Engine Oil"](#) .
4. Remove the following belts.
 - Power steering pump drive belt
 - Alternator drive belt
5. Remove power steering pump from adjusting bar.
6. Remove alternator. Refer to [SC-31, "Removal"](#) .
7. Remove front RH wheel. Refer to [WT-4, "Removal"](#) .
8. Remove front/right-side splash undercover.
9. Remove center member.
10. Remove front exhaust tube. Refer to [EX-3, "Removal and Installation"](#) .

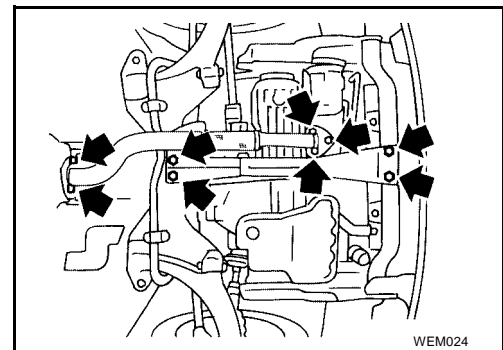
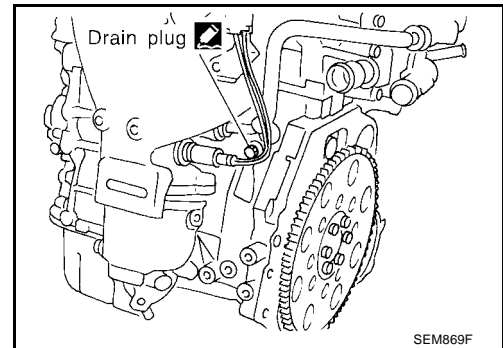

11. Disconnect vacuum hoses for:
 - EVAP canister
 - Brake power booster
12. Remove ignition coils.
13. Remove spark plugs.

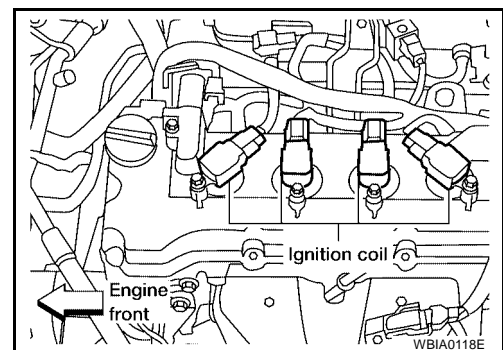

14. Remove rocker cover. Refer to [EM-23, "REMOVAL"](#)
15. Remove oil level gauge.

TIMING CHAIN

[QG18DE]

16. Remove gusset.

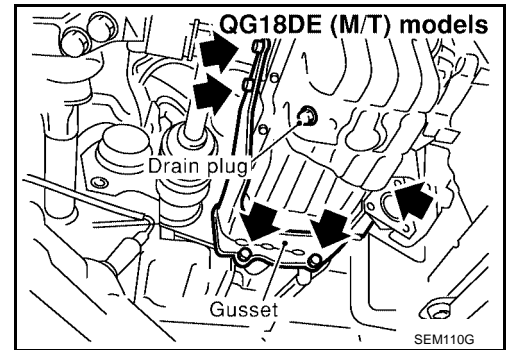
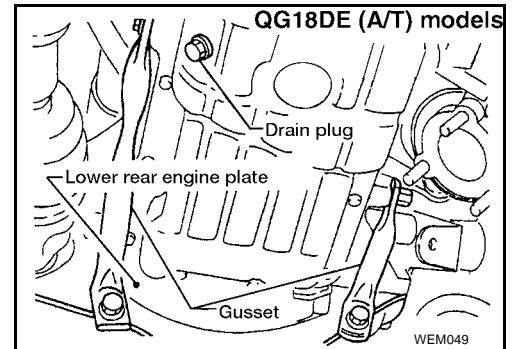

17. Remove rear plate (lower)(A/T models).

18. Remove oil pan and oil strainer. Refer to [EM-16, "Removal"](#).

19. For safe operation, and to reduce load to mount insulator, install center member.

20. Remove RH engine mounting and RH engine mounting bracket. Refer to [EM-63, "ENGINE ASSEMBLY"](#).

a. Remove any parts that make it difficult to remove RH mount.

b. Support cylinder block bottom surface with a transmission jack.

CAUTION:

● When positioning jack, use a wooden block to avoid damage to the oil pan mounting surface.

c. Separate and remove engine mounting bracket and engine mounting.

21. Remove cylinder head front cover.

22. Remove auxiliary bolts of cylinder head.

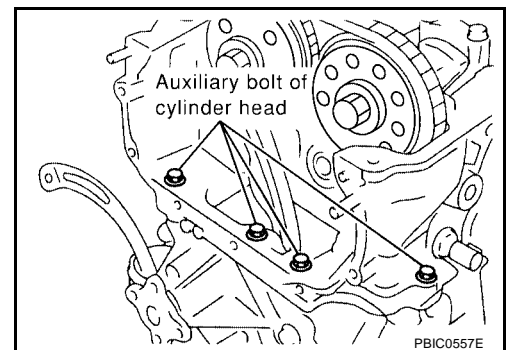

23. Set No. 1 piston at TDC on its compression stroke.

TIMING CHAIN

[QG18DE]

- a. Turn the crankshaft pulley clockwise, and align the pointer to the timing mark on the pulley.

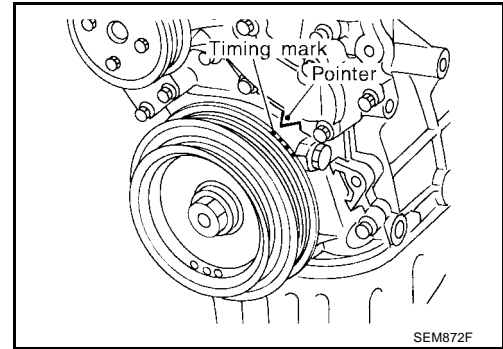

- b. Make sure the camshaft sprocket mating mark is in the position shown in the figure.
- If the mating mark is not in position, turn the crankshaft pulley once more and position it.

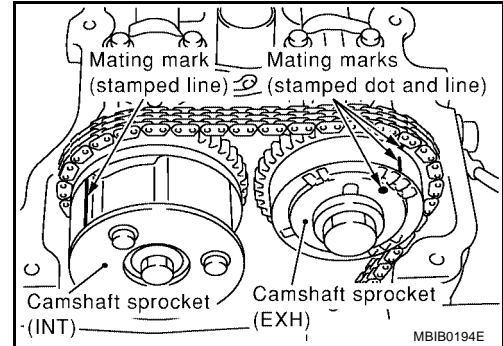

24. Remove crankshaft pulley as follows.

- a. Secure crankshaft counterweight with the handle of a hammer, and loosen crankshaft pulley bolt.

CAUTION:

Take care to prevent foreign material from entering the engine.

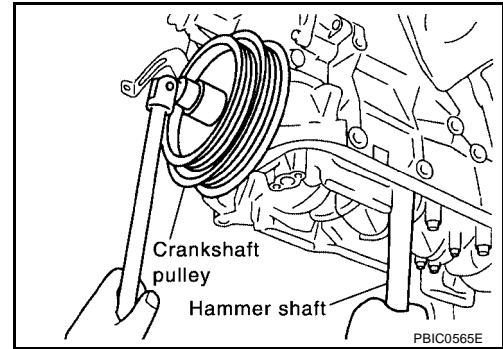

- b. Remove crankshaft pulley using crankshaft pulley puller.

CAUTION:

- Hook tab onto back of crankshaft pulley only.
- Do not remove crankshaft pulley bolt. Fully loosen, and then use it as support point.

25. Remove water pump pulley and idler pulley bracket assembly.

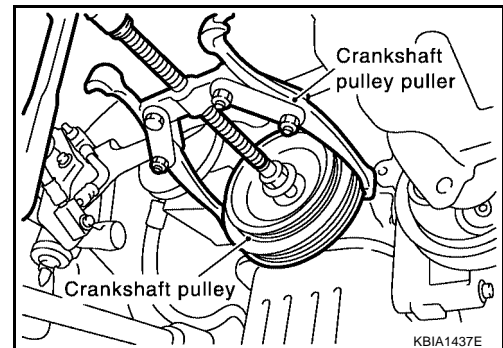

26. Remove front cover as follows.

- a. To ease front cover removal, pull oil pump drive spacer out through front oil seal.

- Pull it straight out using long nose pliers or two flat-bladed screwdrivers.

CAUTION:

Be careful not to damage side of oil pump drive spacer and front oil seal lip.

- b. Remove power steering pump adjusting bar.

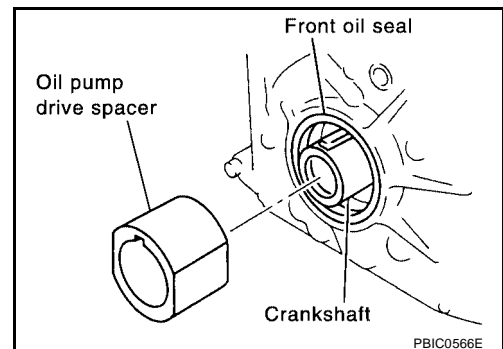

TIMING CHAIN

[QG18DE]

c. Remove front cover carefully.

- Remove mounting bolts A - E shown in figure.

NOTE:

Bolts C and E have been removed in step b.

CAUTION:

- When removing, be careful not to damage or bend front end of cylinder head gasket. Also after peeling off contact surface between front cover and gasket, their surfaces shall be smooth.
- If cylinder head gasket is damaged, replace it with a new one.

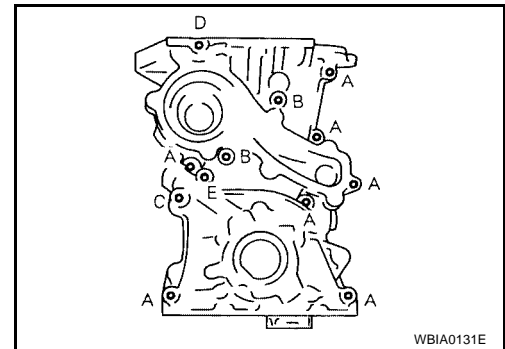

d. Remove O-rings from front cover and cylinder block.

27. Pull two dowel pins for front cover out of cylinder block.

- Heat them sufficiently with industrial dryer, then pull them out using locking pliers.

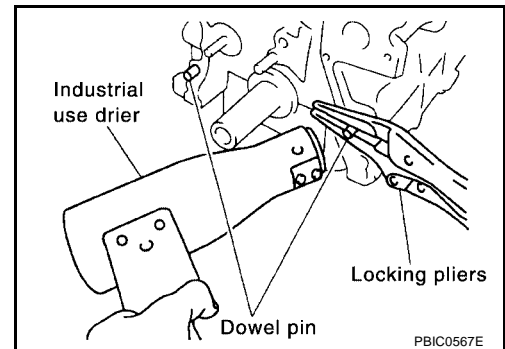

28. If front oil seal is to be replaced, remove it from the front cover.

- Insert a flat-bladed screwdriver in notch on oil seal mounting point, and pry out oil seal.

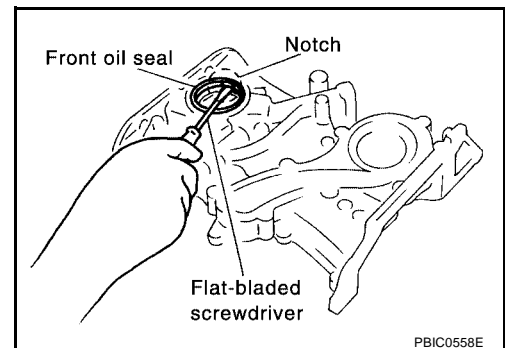

29. Set the intake camshaft sprocket to the most advanced position.

CAUTION:

Do not remove the chain tensioner before performing this step.

CAUTION:

Removal/installation of the intake camshaft sprocket is required to maintain the most advanced position because of the following reasons. Therefore, follow the procedure exactly.

- Sprocket and vane (camshaft in front) rotate and become offset within the specific angle range.
- When engine is stationary, the vane is located at the most retarded position. The vane is fixed to the sprocket by an internal lock pin. Therefore, it does not rotate.
- If the camshaft sprocket mounting bolts are turned under the above circumstance, the lock pin will be damaged by lateral load (shear stress). It may cause non-standard operation.

NOTE:

"Rotating direction" means direction viewed from the engine front side.

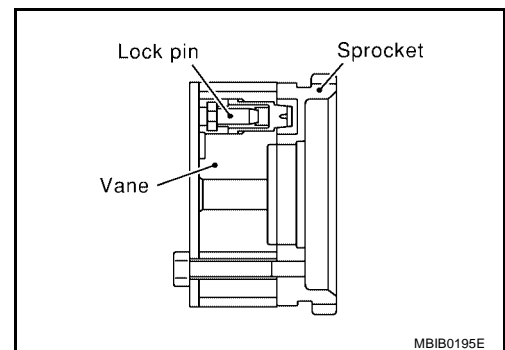

TIMING CHAIN

[QG18DE]

- a. Using a wrench, hold the hexagonal part so that the intake camshaft does not move.

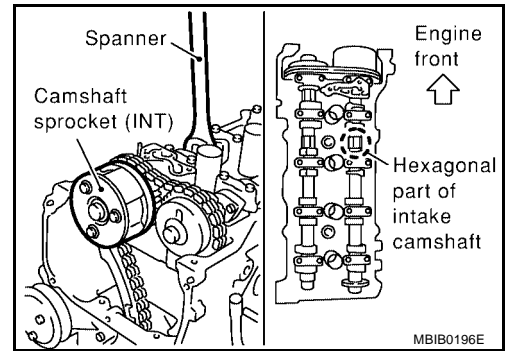

- b. Using an air gun, apply air pressure to the intake valve timing control solenoid valve advance side oil passage on the top surface of the No. 1 camshaft bracket.

Compression pressure :300 kPa (3.06 kg/cm², 43.5 psi) or more

- Keep applying air pressure until substep d is completed.

CAUTION:

- Be careful not to damage the oil passage from interference of the air gun tip.
- Thoroughly wipe off the oil before applying air pressure. When applying air pressure, cover around the air gun using a rag. Wear protective glasses if necessary.

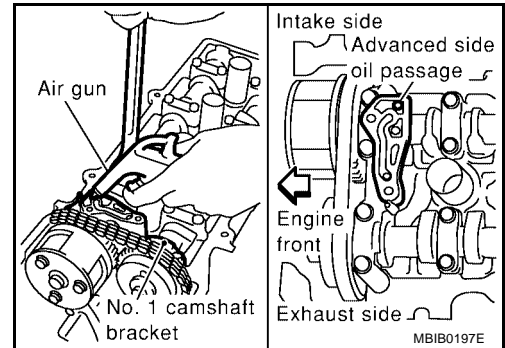

- c. Slowly turn the intake camshaft in direction A (counterclockwise: intake manifold side).

CAUTION:

Be careful not to dislocate the camshaft retaining spanner.

- d. During the above step, an operating click (a sound indicating internal lock pin is disengaged) is heard from the inside of the intake camshaft sprocket. After hearing it, slowly turn intake camshaft in direction B (clockwise: exhaust manifold side), and set to most advanced position.

- Perform while applying air pressure.
- When the vane rotates solely against sprocket, lock pin is disengaged even if operating click is not heard.
- If the lock pin is not disengaged, jiggle the camshaft with a wrench.
- If the lock pin is not disengaged with the above step, tap the intake camshaft in front with a plastic hammer.

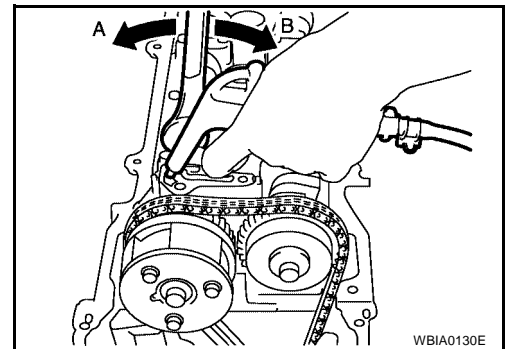

- e. The following status indicates that the most advanced position is achieved: vane starts rotating on its own, then the sprocket also starts rotating when camshaft is turned. When above status is achieved, this step is complete.

- The most advanced position is confirmed when the stopper pin groove and lock pin breathing groove are aligned.

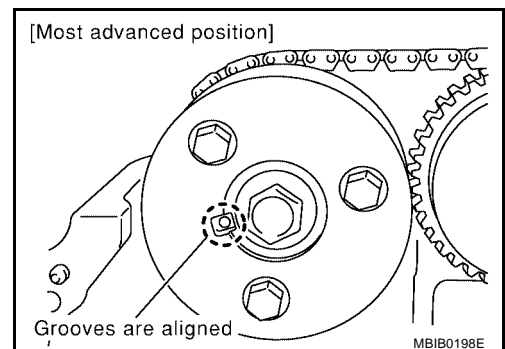

TIMING CHAIN

[QG18DE]

- f. Stop the air and insert stopper pin [approximately 3 mm (0.12 in) dia., length of inserted part is approximately 15 mm (0.59 in)] into pinhole on camshaft sprocket to fix the most advanced position.

CAUTION:

Load (spring reaction force) is not applied to stopper pin. Pin is easily detached. Therefore, secure it with vinyl tape to prevent detachment.

NOTE:

In the figure, an Allen wrench [a/f 2.5 mm (0.098 in), short part: approximately 20 mm (0.79 in), long part: approximately 50 mm (1.97 in)] is used for stopper pin as an example.

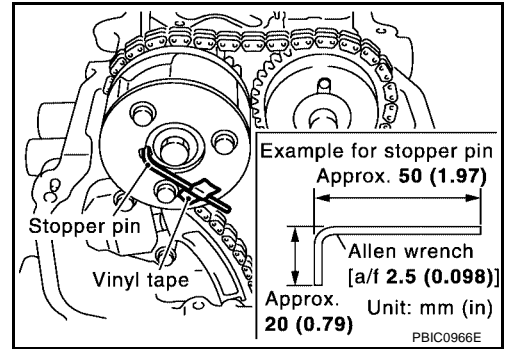

30. Remove the chain tensioner.

- Remove in the following order.

- Press the plate down and release the stopper tab.
- Insert the plunger into the tensioner body until it stops.
- Secure the plate by passing the stopper pin (such as a hard wire) through the plate hole and body hole. (Plunger is also secured.)
- Remove the mounting bolts and remove the chain tensioner.

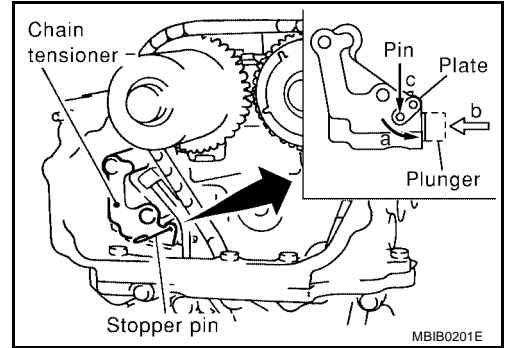

31. While holding the hexagonal part of the camshaft with a wrench, loosen the mounting bolts and remove the intake and exhaust camshaft sprockets.

CAUTION:

- Avoid securing the camshaft at other than the hexagonal part and loosening mounting bolts by utilizing tension of timing chain.
- After this step is completed, do not rotate crankshaft and camshaft separately in order to prevent interference between the valves and pistons.

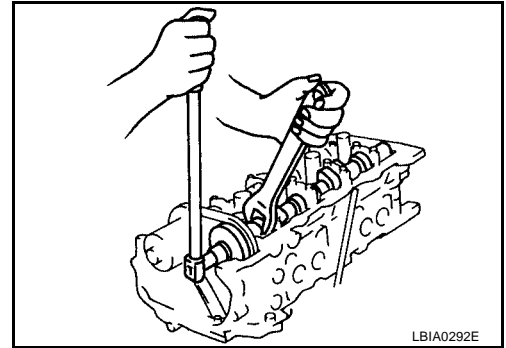

32. Remove the timing chain, timing chain slack guide and tension guide.

33. Remove crankshaft sprocket.

INSPECTION AFTER REMOVAL

Check for cracks and excessive wear at roller links. Replace if necessary.

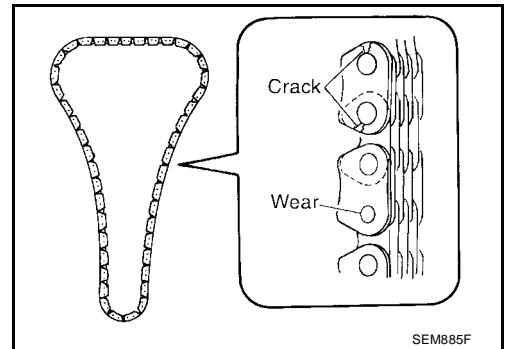

INSTALLATION

CAUTION:

- Use a scraper to completely remove all liquid gasket adhering to mounting surface. De-grease and clean mounting surfaces.
 - After installation, wipe off any protruding liquid gasket.
1. Install timing chain and its related parts as follows.

TIMING CHAIN

[QG18DE]

- Refer to figure for proper alignment positions for the sprockets, timing chain and their related parts.
 - Install each sprocket with its mating mark facing the engine front side.
- a. Install timing chain and crankshaft sprocket.
 - Make sure that the crankshaft key points straight up (No. 1 cylinder is at TDC).
 - Hook timing chain on front end of camshaft so that it will not fall off.
 - b. Install timing chain slack guide and tension guide.
 - c. Install the camshaft sprocket. Refer to [EM-29, "INSTALLATION"](#).
 - d. Install the chain tensioner. Refer to [EM-29, "INSTALLATION"](#).
 - e. Make sure that mating marks are properly aligned.
 - f. Temporarily install the oil pump drive spacer, crankshaft pulley and crankshaft pulley mounting bolt so that the crankshaft can be rotated.
 - g. Rotate crankshaft clockwise several times to make sure it rotates normally.
 - h. Remove parts installed in step f.

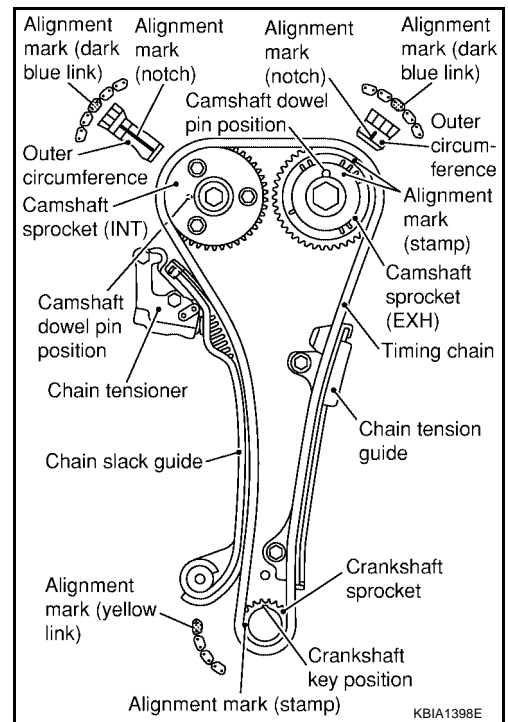

2. Install front oil seal to front cover.
 - Install it so that identification letters on oil seal will face toward front side of the engine.
 - Using an oil seal drift, press oil seal in until it is flush with end surface of mounting position.
 - Make sure that oil seal outer circumference is free from damage and burrs.

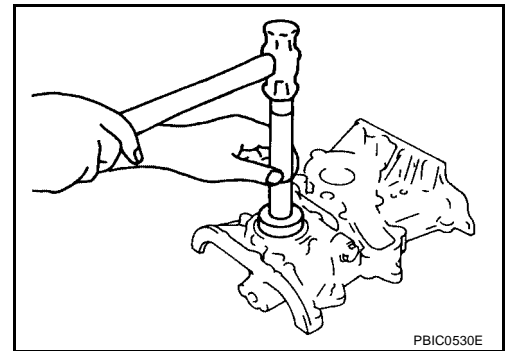

3. Install front cover as follows.
 - a. Install O-ring to cylinder block.
 - b. Apply a continuous bead of sealant to the positions shown in the figure between the cylinder head gasket lower surface and the cylinder block.
 - **Use Genuine RTV Silicone Sealant, or equivalent. Refer to [GI-44, "RECOMMENDED CHEMICAL PRODUCTS AND SEALANTS"](#).**

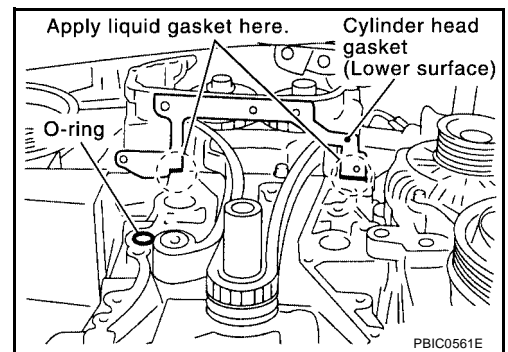

- c. Apply a continuous bead of sealant to the back surface of the front cover as shown in the figure.
 - **Use Genuine RTV Silicone Sealant, or equivalent. Refer to [GI-44, "RECOMMENDED CHEMICAL PRODUCTS AND SEALANTS"](#).**

CAUTION:

 - **Do not apply sealant to groove A shown in figure.**
 - **Be especially careful of amount of sealant being applied in locations indicated with a * in the figure.**
- d. Apply sealant to the top surface of front cover lightly and evenly.

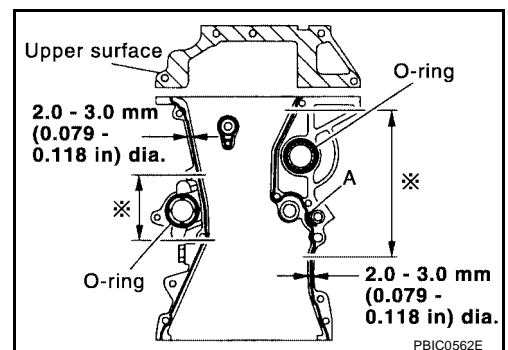

TIMING CHAIN

[QG18DE]

- Use Genuine RTV Silicone Sealant, or equivalent. Refer to [GI-44, "RECOMMENDED CHEMICAL PRODUCTS AND SEALANTS"](#).

- e. Install O-ring to back surface to front cover.
- f. With socket oil pump inner rotor placed on crankshaft top surface (clearance between front cover top surface and cylinder head gasket lower surface is secured), move front cover close to cylinder block.
- g. Lift front cover at an angle and install it to mounting position so that front cover will come in contact with both cylinder head gasket lower surface and cylinder block front surface at the same time.

CAUTION:

- Be careful not to damage cylinder head gasket.
- Make sure both sealing surfaces are contacted at the same time to ensure proper sealant adhesion and location.

- h. Install the front cover with mounting bolts temporarily so that front cover will not move.
- i. Press fit the dowel pin into the cylinder block through the front cover.

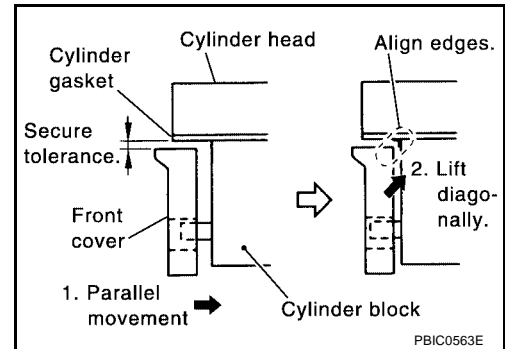

- j. Tighten the front cover mounting bolts temporarily.
- A [M6 x 20 mm (0.79 in)], B [M6 x 40 mm (1.57 in)], C [M8 x 70 mm (2.76)], D [M6 x 73 mm (2.87 in)]
 - Bolt C also secures the power steering pump adjusting bar.
 - Bolt E [M6 x 12 mm (0.47 in)] is for installing power steering pump adjusting bar.
- k. Tighten the cylinder head auxiliary bolts (M6) temporarily.
- l. Tighten the front cover mounting bolts and cylinder head auxiliary bolts to specified torque.

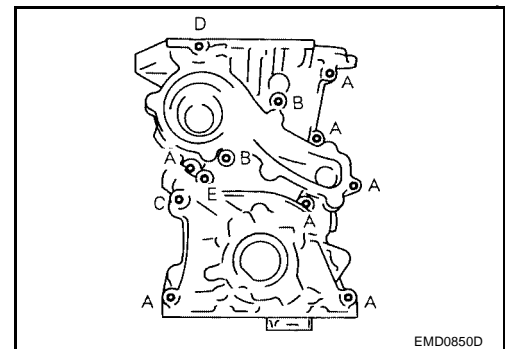
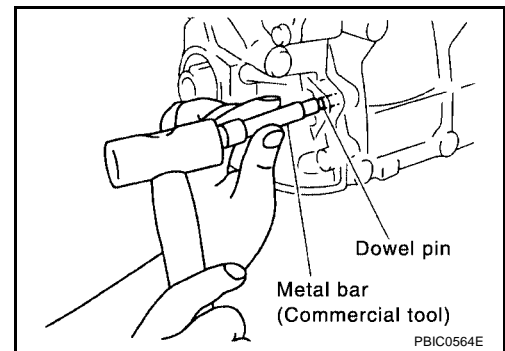

4. Install oil pump drive spacer.
- When installing, align with flat of oil pump rotor.
 - If they are not aligned, rotate inner rotor with a flat-bladed screwdriver to align them.

CAUTION:

- Be careful not to damage oil seal lips.

5. Install water pump pulley and idler pulley bracket assembly.
6. Install crankshaft pulley.
- When installing it, make sure that front oil seal lip is not inverted and garter spring is in position.
 - Secure crankshaft counterweight with the handle of a hammer, and tighten crankshaft pulley bolt.

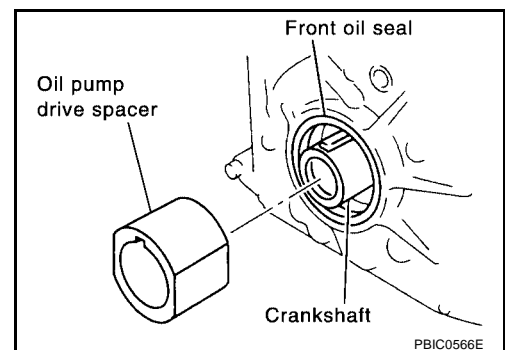

TIMING CHAIN

[QG18DE]

7. Install cylinder head front cover.
 - Apply Silicone RTV Sealant to cylinder head front cover in the specified thickness, as shown.
 - Use Genuine Silicone RTV Sealant or equivalent. Refer to [GI-44, "RECOMMENDED CHEMICAL PRODUCTS AND SEALANTS"](#).
8. Install engine front mounting bracket.

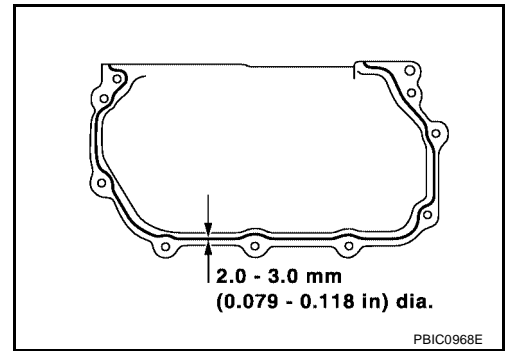

9. Installation of the remaining parts is in reverse order of removal.

INSPECTION AFTER INSTALLATION

EBS00EWJ

- In order to allow sealant to cure, perform inspection at least 30 minutes after the last step involving sealant is installed.
- With engine warmed up, check each part for engine oil leakage.

OIL SEAL

Replacement VALVE OIL SEAL

1. Remove rocker cover. Refer to [EM-23, "Removal and Installation"](#) .
2. Remove camshaft. Refer to [EM-26, "Removal and Installation"](#) .
3. Remove valve spring. Refer to [EM-56, "DISASSEMBLY"](#) .
4. Remove valve oil seal with Tool.

CAUTION:

Piston concerned should be set at TDC to prevent valve from falling into combustion chamber.

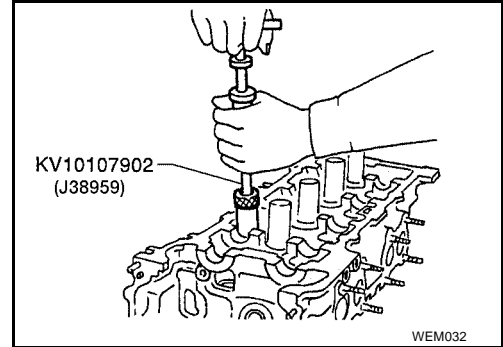

5. Apply new engine oil to new valve oil seal and install it with Tool.

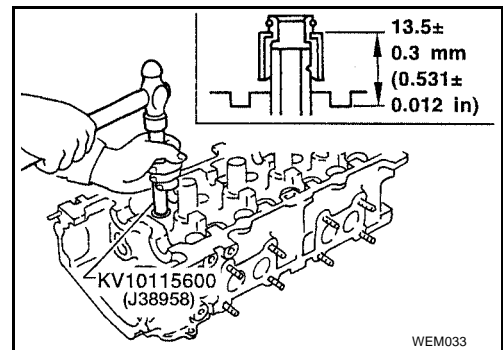

FRONT OIL SEAL

1. Remove the following parts:
 - Engine under cover
 - RH engine side cover
 - Generator and power steering drive belts
 - Crankshaft pulley
2. Remove front oil seal from front cover.
 - **Be careful not to scratch front cover.**

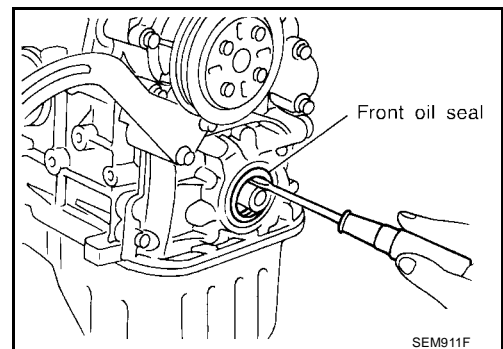

OIL SEAL

[QG18DE]

3. Apply new engine oil to new oil seal and install it using a suitable tool.
 - Install new oil seal in the direction shown.

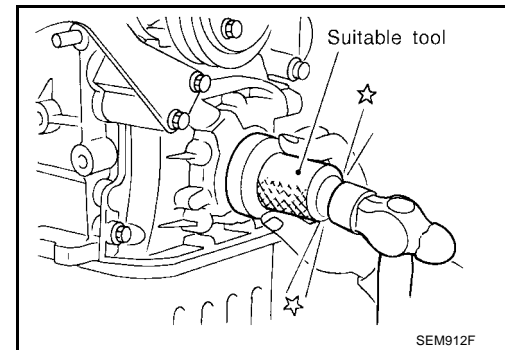
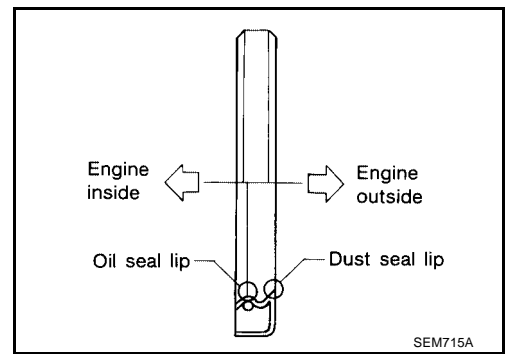

REAR OIL SEAL

1. Remove the transaxle. Refer to [MT-16, "Removal and Installation"](#) (RS5F70A), [MT-82, "Removal and Installation"](#) (RS5F51A), [MT-143, "Removal and Installation"](#) (RS6F51H), or [AT-265, "REMOVAL AND INSTALLATION"](#) (RE4F03B), [AT-649, "REMOVAL AND INSTALLATION"](#) (RE4F04B).
2. Remove flywheel (MT) or drive plate (AT).
3. Remove rear oil seal.
 - **Be careful not to scratch rear oil seal retainer.**

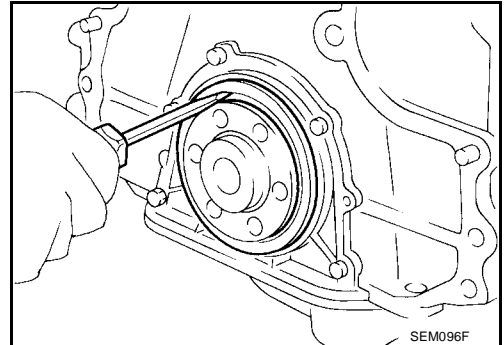

4. Apply new engine oil to new oil seal and install it using a suitable tool.
 - **Install new oil seal in the direction shown.**

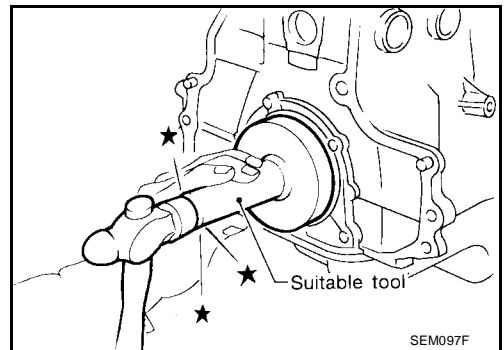
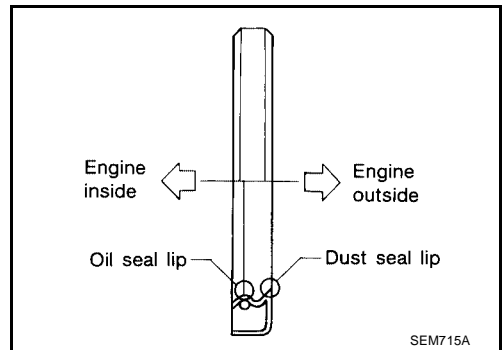

CYLINDER HEAD**On-Vehicle Service****CHECKING COMPRESSION PRESSURE**

1. Warm up the engine to full operating temperature.
2. Turn the ignition switch OFF.
3. Release the fuel pressure. Refer to [EC-56, "FUEL PRESSURE RELEASE"](#) [QG18DE (ULEV)], or [EC-637, "FUEL PRESSURE RELEASE"](#) [QG18DE (SULEV)].
4. Remove the ignition coils.
5. Remove the spark plugs.
 - Clean the area around the spark plug with compressed air before removing the spark plug.
6. Attach a compression tester to No. 1 cylinder.

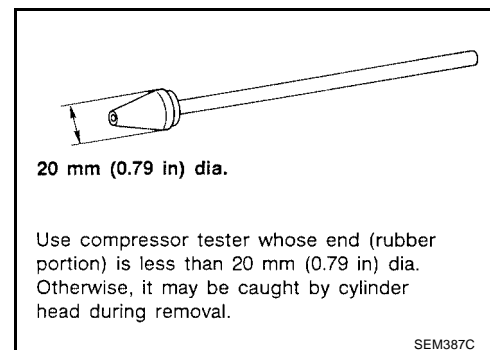
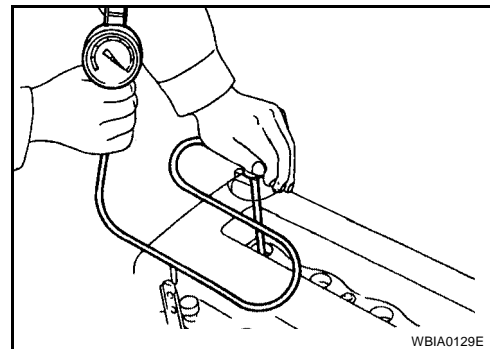

7. Depress the accelerator pedal fully to keep the throttle valve wide open.
8. Crank the engine and record highest gauge indication.
9. Repeat the measurement on each cylinder as shown above.
 - **Always use a fully-charged battery to obtain specified engine speed.**

Compression pressure	: kPa (kg/cm² , psi)/rpm
Standard	: 1,324 (13.5, 192)/350
Minimum	: 1,157 (11.5, 168)/350
Maximum allowable difference between cylinders	: 98 (1.0, 14)/350
10. If cylinder compression in one or more cylinders is low, pour a small amount of engine oil into the cylinder through the spark plug hole and retest compression.
 - **If adding oil improves cylinder compression, piston rings may be worn or damaged. If so, replace piston rings after checking the piston and cylinder walls.**
 - **If pressure stays low, a valve may be sticking or seating improperly. Inspect and repair valve and valve seat. Refer to [EM-35, "INSPECTION"](#) , [EM-60, "VALVE SEATS"](#) . If valve or valve seat is damaged excessively, replace them.**
 - If compression in any two adjacent cylinders is low and if adding oil does not improve compression, there is leakage past the gasket surface. If so, replace cylinder head gasket.
11. Install spark plugs, ignition coils and fuel pump fuse.

12. Erase DTC if any DTC appears. Refer to [EC-71, "HOW TO ERASE EMISSION-RELATED DIAGNOSTIC INFORMATION"](#) [QG18DE (ULEV)], or [EC-651, "HOW TO ERASE EMISSION-RELATED DIAGNOSTIC INFORMATION"](#) [QG18DE (SULEV)].

Removal and Installation

EBS00CEN

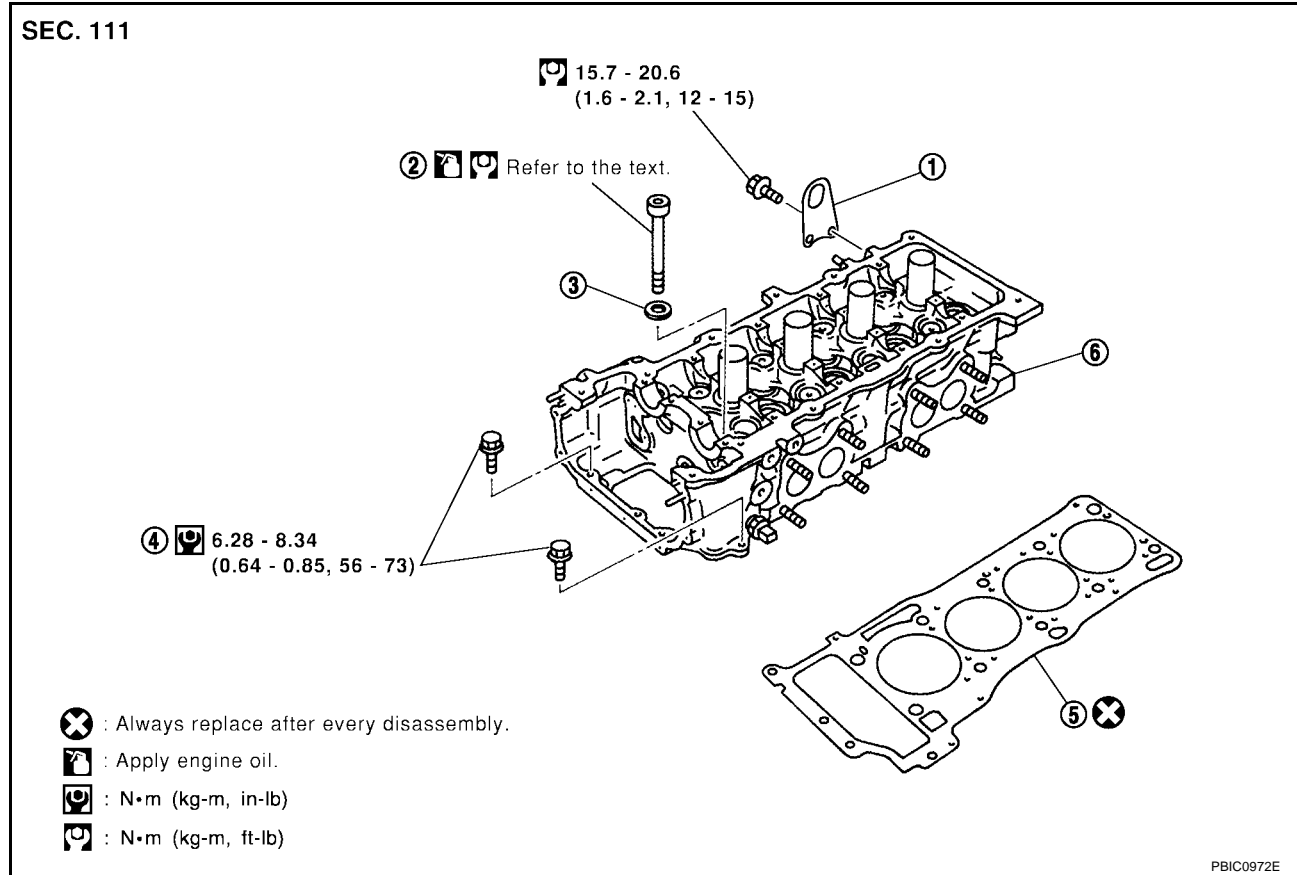

- | | | |
|------------------------------------|-------------------------|---------------------------|
| 1. Rear engine slinger | 2. Cylinder head bolt | 3. Washer |
| 4. Auxiliary bolt of cylinder head | 5. Cylinder head gasket | 6. Cylinder head assembly |

CAUTION:

- When installing camshaft and oil seal, lubricate contacting surfaces with new engine oil.
- When tightening cylinder head bolts, camshaft sprocket bolts and camshaft bracket bolts, lubricate bolt threads and seat surfaces with new engine oil.
- Attach tags to valve lifters so as not to mix them up.

REMOVAL

1. Drain engine coolant.
Be careful not to spill coolant on drive belts.

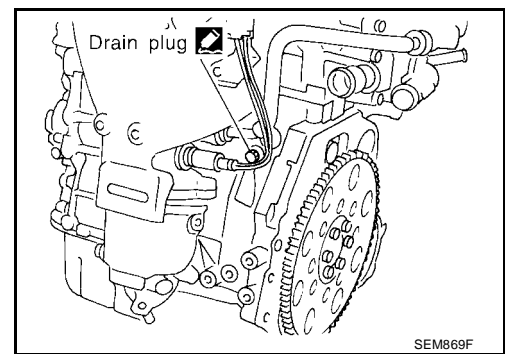

2. Release the fuel pressure. Refer to [EC-56, "FUEL PRESSURE RELEASE"](#) for [QG18DE (ULEV)], or [EC-637, "FUEL PRESSURE RELEASE"](#) for [QG18DE (SULEV)].
3. Remove the air duct to intake manifold collector.
4. Remove the engine drive belts.

5. Remove the front splash undercovers.
6. Remove the front exhaust tube.
7. Before removing the intake manifold collector from the engine, the following parts should be disconnected to remove the intake manifold collector:
 - Fuel injector tube quick connectors. Refer to [EM-19, "FUEL INJECTOR AND FUEL TUBE"](#) .
 - Ground harness
 Harness connectors for:
 - Electric throttle control actuator
 - Heated oxygen sensor (ULEV) or Air fuel ratio (A/F) sensor (SULEV only)
 - Swirl control position sensor (SULEV only)
 - Swirl control valve (SULEV only)
 - Water hoses from collector
 - Heater hoses
 - PCV hose
 Vacuum hoses for:
 - EVAP canister
 - Power brake booster
8. Remove the intake manifold rear supports.
9. Remove the exhaust manifold.
10. Remove the spark plugs.
11. Remove rocker cover. Refer to [EM-23, "ROCKER COVER"](#) .
12. Remove camshafts. Refer to [EM-26, "CAMSHAFT"](#) .

13. Remove cylinder head bolts.
 - Cylinder head bolts should be loosened in two or three steps.

CAUTION:
Head warping or cracking could result from removing the cylinder head bolts in incorrect order.
14. Remove cylinder head with intake manifold.

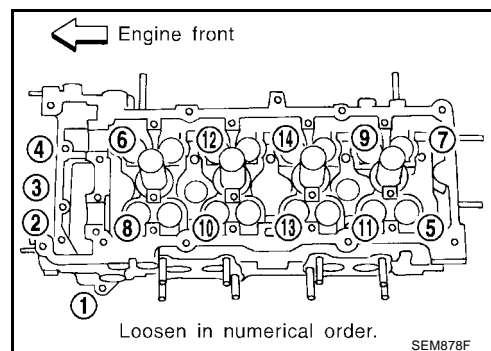

INSTALLATION

1. Before installing cylinder head gasket, apply a bead of Genuine RTV Silicone Sealant or equivalent, to mating surface of cylinder block as shown. Refer to [GI-44, "RECOMMENDED CHEMICAL PRODUCTS AND SEALANTS"](#) .
2. Install the cylinder head gasket.
 - **When installing the cylinder head with manifolds, use a new cylinder head gasket.**

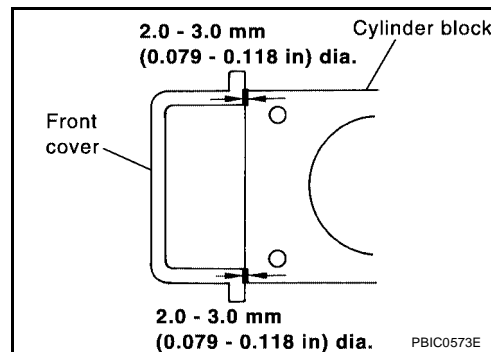

CYLINDER HEAD

[QG18DE]

- Install cylinder head assembly and cylinder head bolts with washers.
 - Apply new engine oil to threads and seating surface of mounting bolts.

CAUTION:

- Be sure to install washers between bolts and cylinder head with washer orientation as shown.

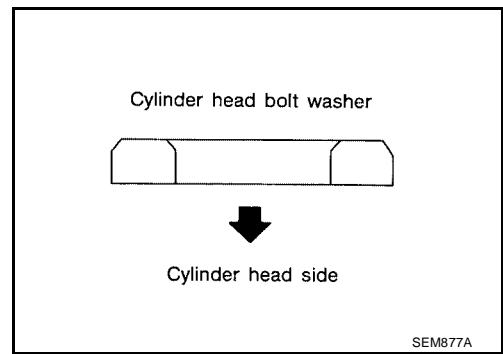

- Tighten cylinder head bolts (1) to (10) in numerical order as shown in five stages.

Cylinder head bolts

- Stage 1 : 29.4 N-m (3.0 kg-m, 22 ft-lb)
- Stage 2 : 58.8 N-m (6.0 kg-m, 43 ft-lb)
- Stage 3 : 0 N-m (0 kg-m, 0 ft-lb) (loosen)
- Stage 4 : 27.4 - 31.4 N-m (2.8 - 3.2 kg-m, 21 - 23 ft-lb)
- Stage 5 : 50° - 55° (target 50°) clockwise

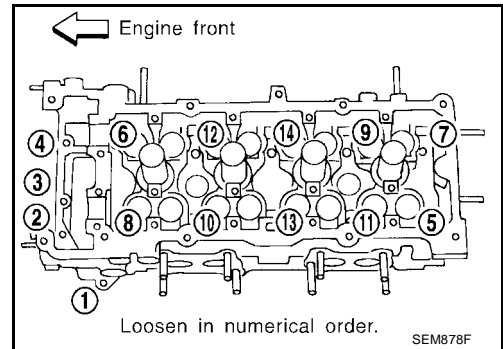
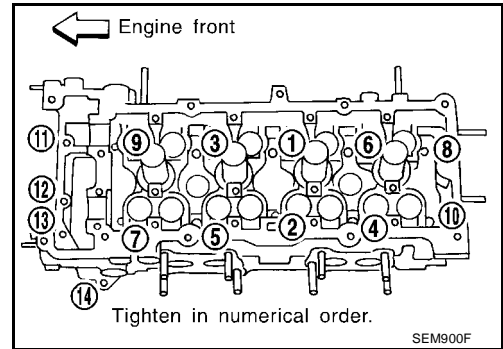

CAUTION:

Check and confirm the tightening angle by using angle wrench.

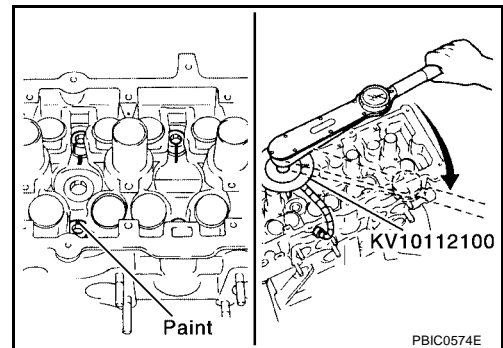

A
EM
C
D
E
F
G
H
I
J
K
L
M

CYLINDER HEAD

[QG18DE]

5. Tighten cylinder auxiliary bolts (11) to (14) in numerical order shown in figure.
 - Verify shank length under bolt head. [Bolt 11: 20 mm (0.79 in), bolts 12 - 14: 25 mm (0.98 in)]
6. Install the remaining components in the reverse order of removal.

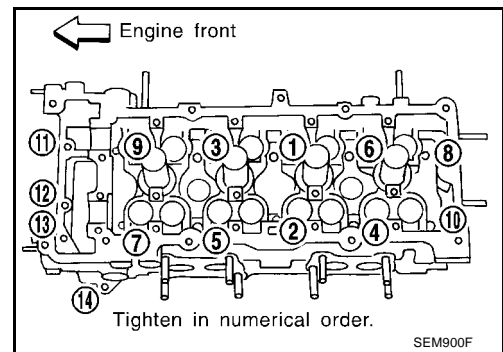

Disassembly and Assembly

EBS00EWV

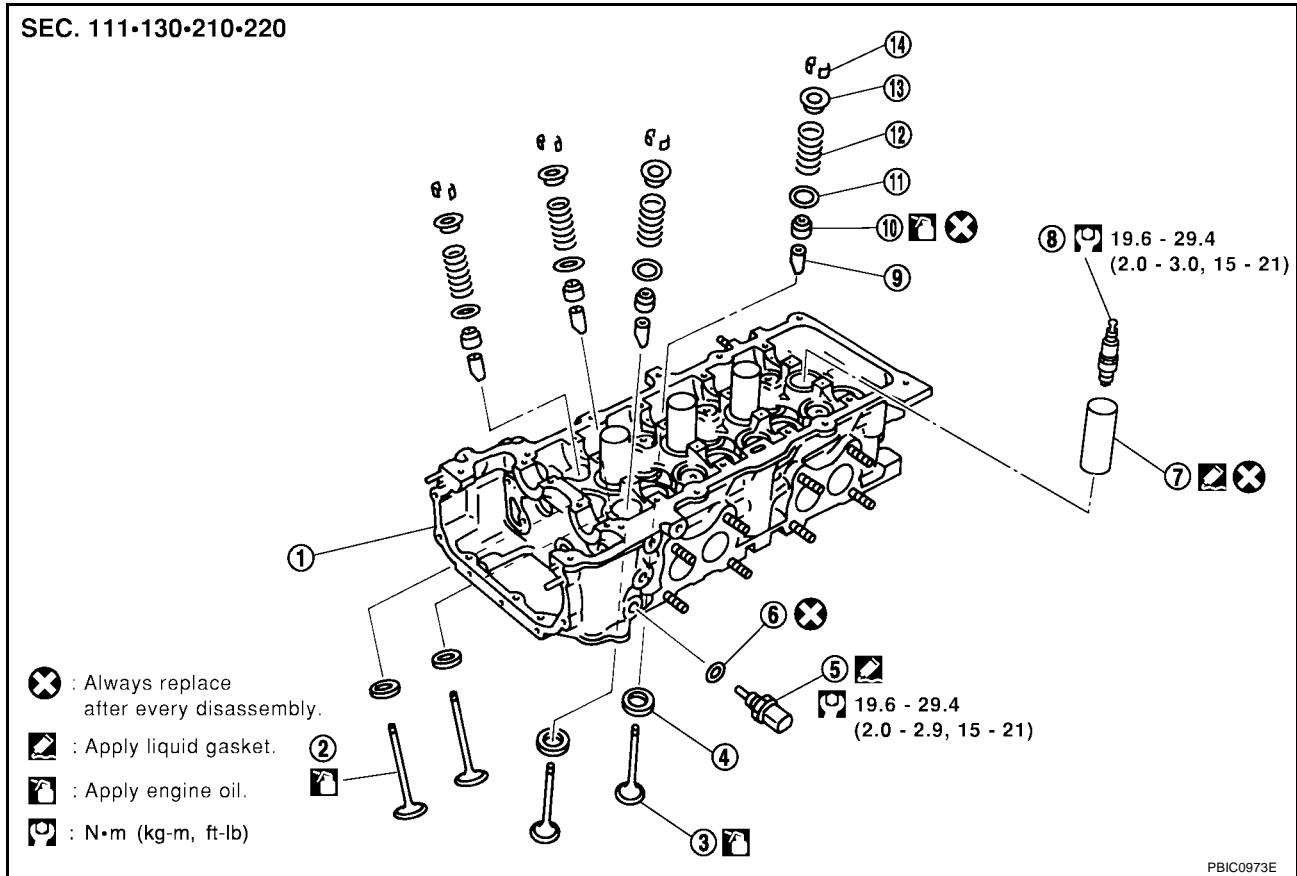

PBIC0973E

- | | | |
|--------------------|--------------------------------------|------------------|
| 1. Cylinder head | 2. Valve (INT) | 3. Valve (EXH) |
| 4. Valve seat | 5. Engine coolant temperature sensor | 6. Copper washer |
| 7. Spark plug tube | 8. Spark plug | |

CAUTION:

- When installing camshafts, chain tensioners, oil seals or other sliding parts, lubricate contacting surface with new engine oil.
- Apply new engine oil to threads and seat surface when installing cylinder head, camshaft sprocket, crankshaft pulley and camshaft bracket.
- Note valve lifter positions so as to ensure proper installation locations.

DISASSEMBLY

1. Remove intake manifold assembly.
2. Remove adjusting shims (if equipped) and valve lifters.
 - Note locations for installation.

CYLINDER HEAD

[QG18DE]

3. Remove valve collet.
 - compress valve spring using Tool as shown. Remove valve collet with magnet.
4. Remove valve spring retainer and valve spring.
5. Push valve stem through the combustion chamber side, and remove valve.
 - Inspect valve guide clearance before removal. Refer to [EM-58, "VALVE GUIDE CLEARANCE"](#).
 - Label components for installation in the same location.

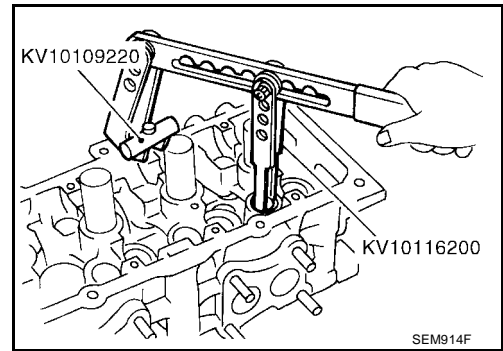

6. Remove valve oil seal using Tool as shown.
7. Remove valve spring seat.
8. When valve seat must be replaced, refer to [EM-60, "REPLACING VALVE SEAT FOR SERVICE PARTS"](#).
9. When valve guide must be replaced, refer to [EM-59, "VALVE GUIDE REPLACEMENT"](#).
10. Remove spark plugs.
11. Remove engine coolant temperature sensor.

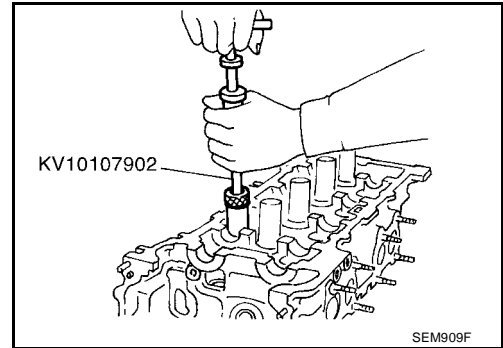

CAUTION:

Do not shock it.

12. Remove spark plug tubes, as necessary.
 - Using a pair of pliers, pull spark plug tube out of cylinder head.

CAUTION:

● **Take care not to damage cylinder head.**

● **Spark plug tubes are deformed during removal and cannot be reused once removed. Do not remove unless necessary.**

ASSEMBLY

1. If removed, install valve seat, refer to [EM-60, "REPLACING VALVE SEAT FOR SERVICE PARTS"](#).
2. If removed, install valve guide, refer to [EM-59, "VALVE GUIDE REPLACEMENT"](#).
3. Install valve oil seal using Tool as shown.
4. Install valve spring seat.
5. Install valve.
 - Install large diameter to intake side.
6. Install valve spring.
7. Install valve spring retainer.

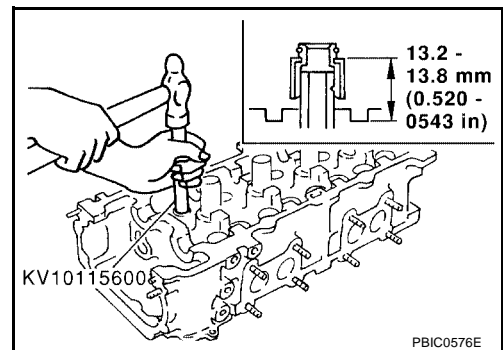

8. Install valve collet.
 - Compress valve spring using Tool as shown. Install valve collet with magnet.
 - Tap stem edge lightly with plastic hammer after installation to check if installed securely.
9. Install adjusting shim, if equipped, using Tool.
10. Apply sealant to engine coolant temperature sensor threads.
 - Use Genuine Anaerobic Liquid Gasket, or equivalent. Refer to [GI-44, "RECOMMENDED CHEMICAL PRODUCTS AND SEALANTS"](#).
11. Install engine coolant temperature sensor.

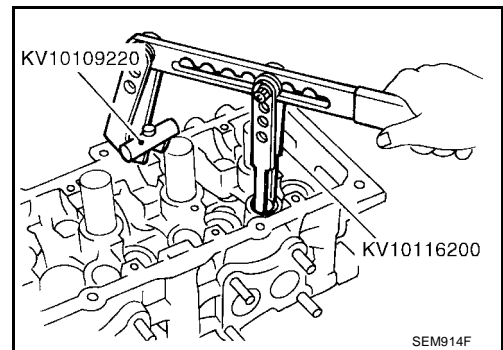

CYLINDER HEAD

[QG18DE]

12. Install spark plug tube.
 - Press-fit spark tube as follows.
 - a. Remove old liquid gasket adhering to cylinder-head mounting hole.
 - b. Apply liquid gasket to area within approximately 15 mm (0.59 in) from edge of spark plug tube press-fit side as shown.
 - Use **Genuine Anaerobic Liquid Gasket, or equivalent.** Refer to [GI-44, "RECOMMENDED CHEMICAL PRODUCTS AND SEALANTS"](#).
 - c. Using a drift, press-fit the spark plug tube so that its height "H" is as shown.

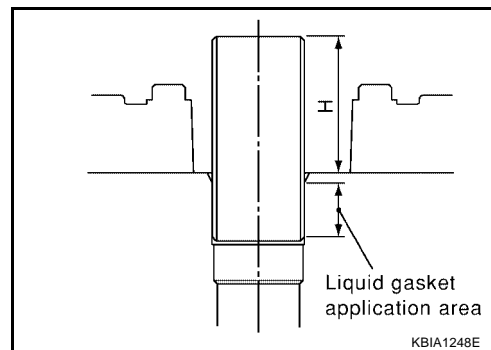

Standard press-fit height "H" : 41.0 - 42.0 mm (1.61 - 1.65 in)

CAUTION:

- When press-fitting, take care not to deform spark plug tube.
 - After press-fitting, wipe off liquid gasket protruding onto cylinder head upper surface.
13. Install spark plugs. Refer to [EM-12, "OUTER COMPONENT PARTS"](#).
 14. Install intake manifold. Refer to [EM-12, "OUTER COMPONENT PARTS"](#).

Inspection after Disassembly CYLINDER HEAD DISTORTION

EBS00CEP

1. Clean surface of cylinder head.
2. Use a reliable straightedge and feeler gauge to check the flatness of cylinder head mating surface.
 - Check along six positions as shown.

Head surface flatness

Standard : Less than 0.03 mm (0.0012 in)

Limit : 0.1 mm (0.004 in)

If beyond the specified limit, replace or resurface it.

Resurfacing limit:

The limit for cylinder head resurfacing is determined by the amount of cylinder block resurfacing.

Amount of cylinder head resurfacing is "A".

Amount of cylinder block resurfacing is "B".

**The maximum limit is : $A + B = 0.2 \text{ mm (0.008 in)}$
as follows**

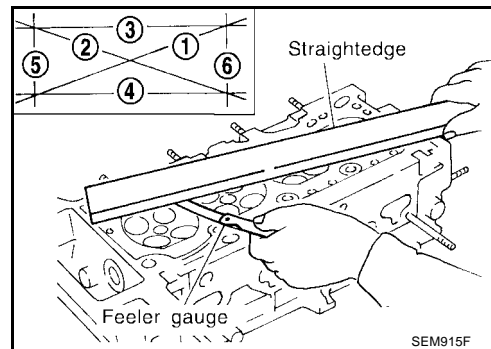

After resurfacing cylinder head, check that camshaft rotates freely by hand. If resistance is felt, replace cylinder head.

Nominal cylinder head height : 117.8 - 118.0 mm (4.638 - 4.646 in)

VALVE GUIDE CLEARANCE

1. Measure valve deflection as shown in figure. (Valve and valve guide wear the most in this direction.)

Valve deflection limit (dial gauge reading)

Intake & Exhaust : 0.2 mm (0.008 in)

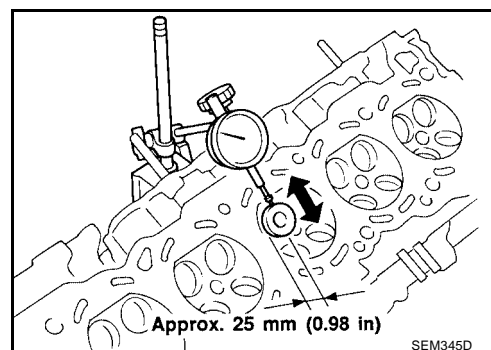

CYLINDER HEAD

[QG18DE]

2. If it exceeds the limit, check valve to valve guide clearance.
 - a. Measure valve stem diameter and valve guide inner diameter.
 - b. Calculate valve to valve guide clearance.
Valve stem to valve guide clearance = valve guide inner diameter – valve stem diameter.
 - c. Check that clearance is within specification.

Unit: mm (in)

	Standard	Limit
Intake	0.020 - 0.050 (0.0008 - 0.0020)	0.1 (0.004)
Exhaust	0.040 - 0.070 (0.0016 - 0.0028)	0.1 (0.004)

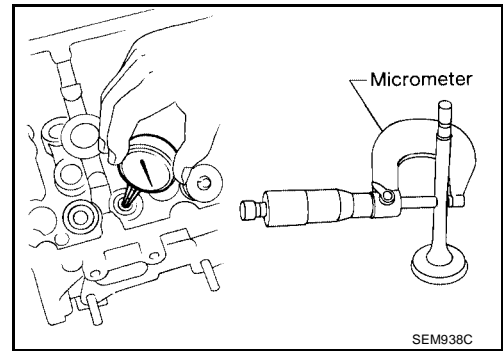

- If it exceeds the limit, replace valve and remeasure clearance.
- If limit is still exceeded after replacing valve, replace valve guide.

VALVE GUIDE REPLACEMENT

1. To remove valve guide, heat cylinder head to 110° to 130°C (230° to 266°F).

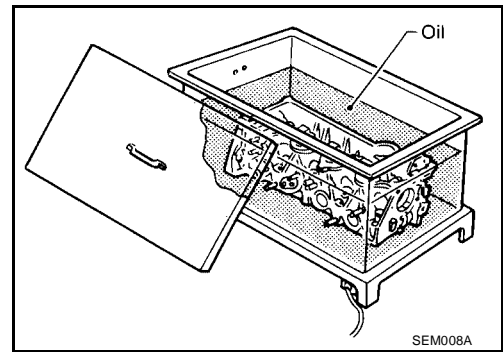

2. Drive out valve guide with a press [under a 20 kN (2 ton, 2.2 US ton, 2.0 Imp ton) pressure] or hammer and suitable tool.

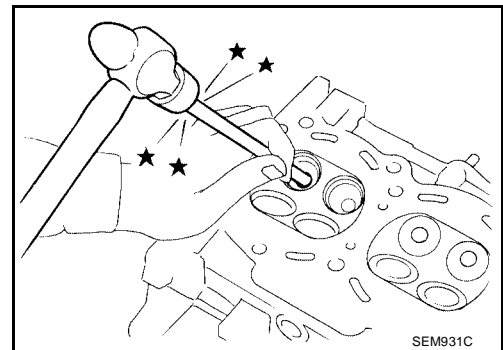

3. Ream cylinder head valve guide hole.

Valve guide hole diameter (for service parts)
Intake & Exhaust : 9.685 - 9.696 mm
(0.3813 - 0.3817 in)

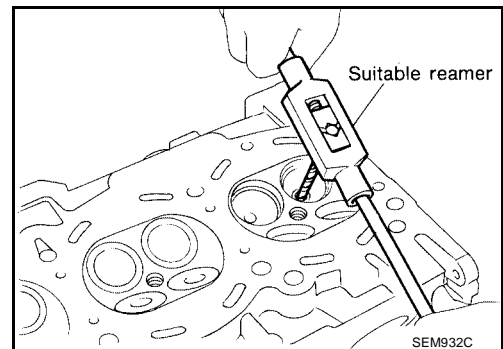

CYLINDER HEAD

[QG18DE]

- Heat cylinder head to 110° to 130°C (230° to 266°F) and press service valve guide into cylinder head at specified height.

Projection "L" : 11.5 - 11.7 mm (0.453 - 0.461 in)

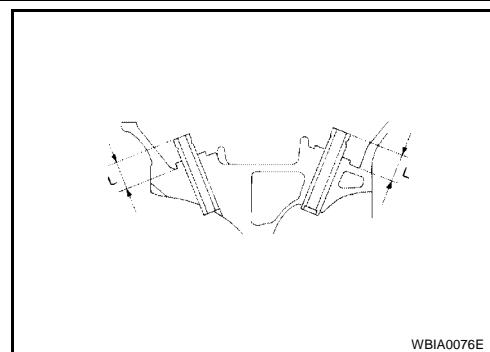

- Ream the new valve guide to the specified inner diameter.

Inner diameter finished size

**Intake & Exhaust : 5.500 - 5.515 mm
(0.2165 - 0.2171 in)**

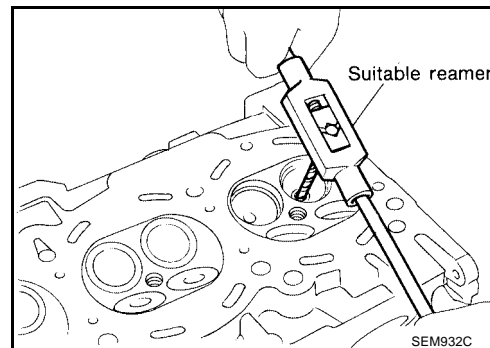

VALVE SEATS

Check valve seats for pitting at contact surface. Resurface or replace if excessively worn.

- Before repairing valve seats, check valve and valve guide for wear. If they have worn, replace them. Then correct valve seat.
- Use both hands to cut uniformly.

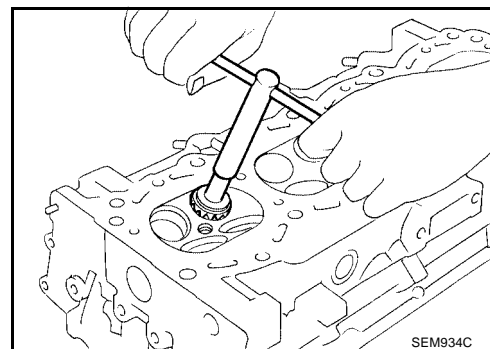

REPLACING VALVE SEAT FOR SERVICE PARTS

- Bore out old seat until it collapses. Set machine depth stop so that boring cannot contact the bottom face of seat recess in cylinder head.
- Ream cylinder head recess. Refer to [EM-85, "Valve Seat"](#) for the reaming bore for the service valve seat.

NOTE:

Use the valve guide center for reaming to ensure valve seat will have the correct fit.

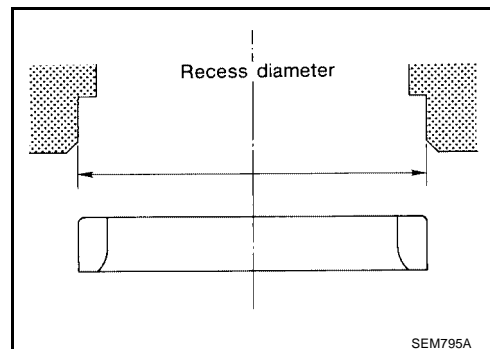

CYLINDER HEAD

[QG18DE]

- Heat cylinder head to 110° to 130°C (230° to 266°F).
- Press fit valve seat until it seats on the bottom.
- Cut or grind valve seat using suitable tool to the specified dimensions. Refer to [EM-82, "Valve"](#).
- After cutting, lap valve seat with abrasive compound.

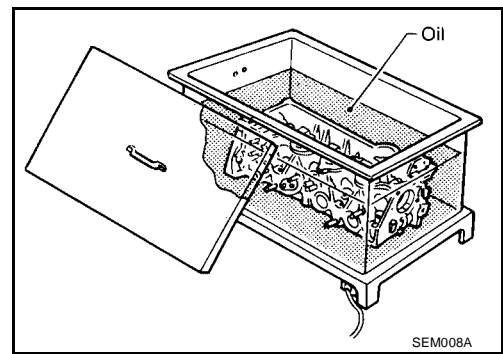

- Check valve seating condition.

Seat face angle "α"	: 44°53' - 45°07'
Contacting width "W"	
Intake	: 1.06 - 1.34 mm (0.0417 - 0.0528 in)
Exhaust	: 1.34 - 1.63 mm (0.0528 - 0.0642 in)

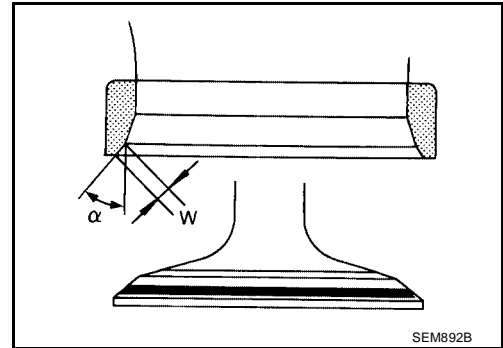

- Use a depth gauge to measure the distance "L" between the mounting surface of the cylinder head spring seat and the valve stem end. If the distance is shorter than specified, repeat step 5 above to correct it. If the distance is longer, replace the valve seat.

Valve seat resurface limit	
Intake	: 35.95 - 36.55 mm (1.4154 - 1.4390 in)
Exhaust	: 35.92 - 36.52 mm (1.4142 - 1.4378 in)

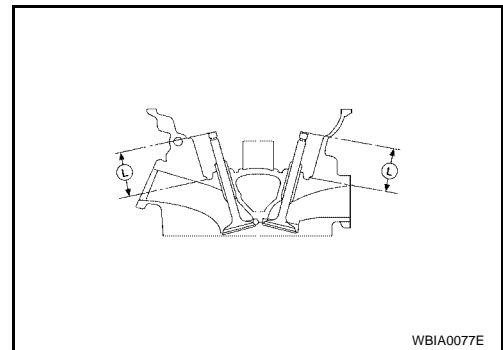

VALVE DIMENSIONS

Check dimensions of each valve. Refer to [EM-82, "Valve"](#).

VALVE SPRING

Squareness

- Measure dimension "S".

Out-of-square "S"	: Less than 1.75 mm (0.0689 in)
--------------------------	--

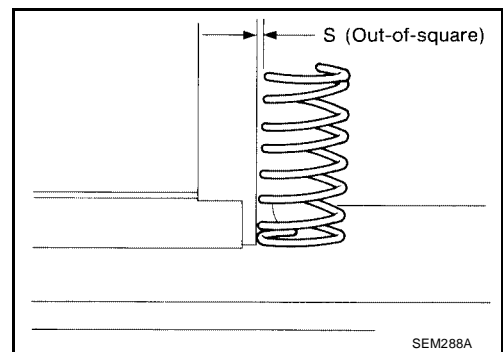

- If it exceeds the limit, replace the spring.

CYLINDER HEAD

[QG18DE]

Pressure

Check valve spring pressure at specified spring height.

Pressure

Standard : 370.0 N (37.73 kg, 83.19 lb) at 23.64 mm (0.9307 in)

Limit : More than 347.8 N (35.46 kg, 78.19 lb) at 23.64 mm (0.9307 in)

If not within specification, replace the spring.

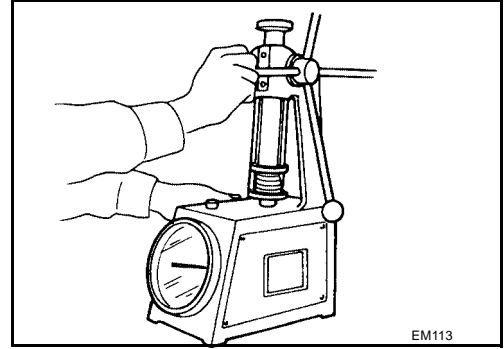

ENGINE ASSEMBLY Removal and Installation

SEC. 112

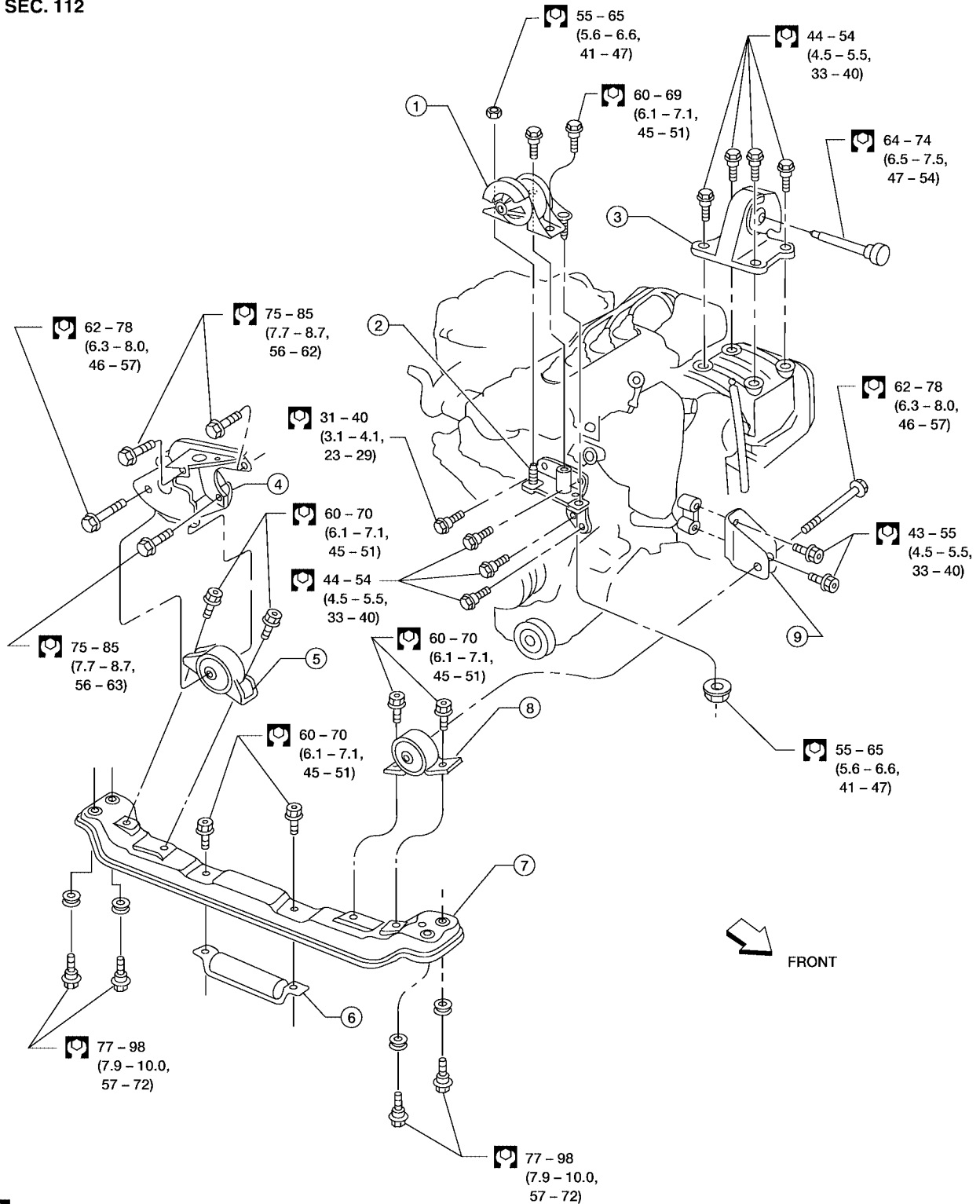

: N·m (kg·m, ft·lb)

- | | | |
|---------------------------------|-------------------------------|----------------------------------|
| 1. RH engine mounting | 2. RH engine mounting bracket | 3. LH engine mounting |
| 4. Rear engine mounting bracket | 5. Rear engine mounting | 6. Dynamic damper |
| 7. Center member | 8. Front engine mounting | 9. Front engine mounting bracket |

WBIA0206E

WARNING:

- Position vehicle on a flat and solid surface.
- Place chocks at front and back of rear wheels.
- Do not remove engine until exhaust system has completely cooled off, otherwise, you may burn yourself and/or fire may break out in fuel line.
- Before disconnecting fuel hose, release pressure. Refer to [EC-56, "FUEL PRESSURE RELEASE"](#) [QG18DE (ULEV)], or [EC-637, "FUEL PRESSURE RELEASE"](#) [QG18DE (SULEV)].
- Be sure to lift engine and transaxle in a safe manner.
- For engines not equipped with engine slingers, attach proper slingers and bolts described in PARTS CATALOG.

CAUTION:

- When lifting engine, be sure to clear surrounding parts. Use special care near accelerator wire casing, brake lines and brake master cylinder.
- When lifting the engine, always use engine slingers in a safe manner.
- When removing drive shaft, be careful not to damage grease seal of transaxle.
- Before separating engine and transaxle, remove crankshaft position sensor (POS) from the cylinder block assembly.
- Always be extra careful not to damage edge of crankshaft position sensor (POS), or signal plate teeth.

Engine cannot be removed separately from transaxle. Remove engine with transaxle as an assembly.

REMOVAL

1. Refer to [EC-56, "FUEL PRESSURE RELEASE"](#) [QG18DE (ULEV)], or [EC-637, "FUEL PRESSURE RELEASE"](#) [QG18DE (SULEV)].
2. Drain coolant from radiator and cylinder block. Refer to [MA-16, "DRAINING ENGINE COOLANT"](#) .
3. Remove coolant reservoir tank.
4. Drain engine oil. Refer to [MA-20, "Changing Engine Oil"](#) .
5. Remove battery and battery tray. Refer to [SC-4, "BATTERY"](#) .
6. Remove air cleaner and air duct.
7. Remove drive belts.
8. Remove generator and air conditioner compressor from engine and position aside. Refer to [SC-31, "Removal"](#) , [MTC-68, "Removal and Installation"](#) .
9. Remove power steering oil pump from engine and position aside. Refer to [PS-21, "COMPONENTS"](#) .

NOTE:

Power steering oil pump does not need to be disconnected from power steering tubes.

10. Remove the following parts:
 - RH and LH front tires
 - Front splash undercovers
 - RH and LH drive shaft. Refer to [FAX-14, "Removal"](#) .

CAUTION:

When removing the drive shaft, be careful not to damage transaxle side grease seal.

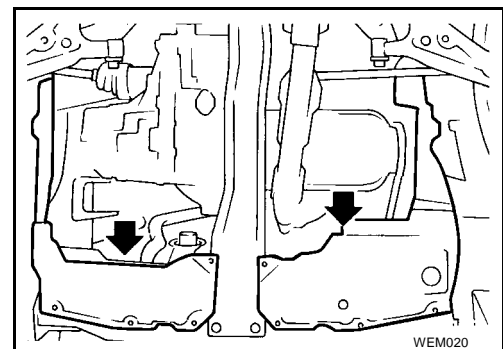

- Disconnect control rod and support rod from transaxle (M/T models).
- Disconnect control cable from transaxle (A/T models). Refer to [AT-263, "Control Cable Adjustment"](#) .

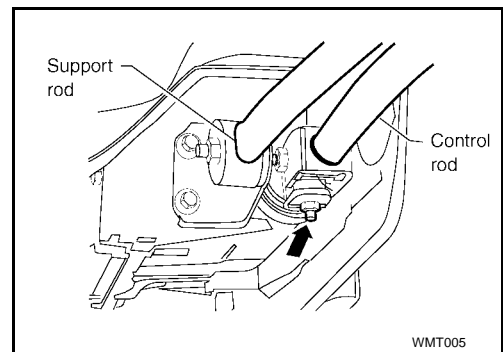

- Center member
- Front exhaust tube. Refer to [EX-3, "Removal and Installation"](#) .
- Stabilizer bar. Refer to [FSU-11, "Removal and Installation"](#) .
- Radiator/Cooling fan. Refer to [CO-13, "Removal"](#) .
- Fuel injector tube quick connectors (Refer to [EM-19, "FUEL INJECTOR AND FUEL TUBE"](#) .)

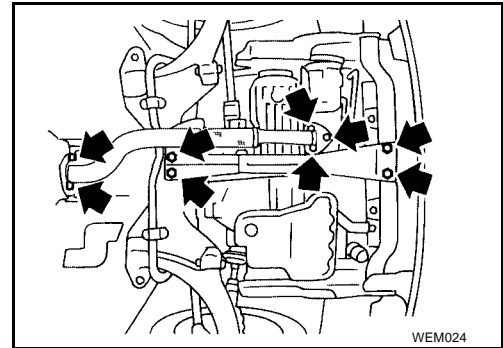

- Ground harness

Harness connectors for:

- Electric throttle control actuator
- Swirl control valve (SULEV only)
- Swirl control position switch (SULEV only)
- Heated oxygen sensor (ULEV only) or Air fuel ratio (A/F) sensor SULEV only)
- Water hoses from collector
- Heater hoses
- PCV hose
- Intake valve timing control solenoid

Vacuum hoses for:

- EVAP canister
- Power brake booster

11. If necessary, install engine slingers and support engine from above with a hoist.
12. Lift up engine slightly and disconnect or remove all engine mountings.

CAUTION:

When lifting engine, be sure to clear surrounding parts. Use special care near brake tubes and brake master cylinder.

A
EM
C
D
E
F
G
H
I
J
K
L
M

13. Remove engine with transaxle as shown.

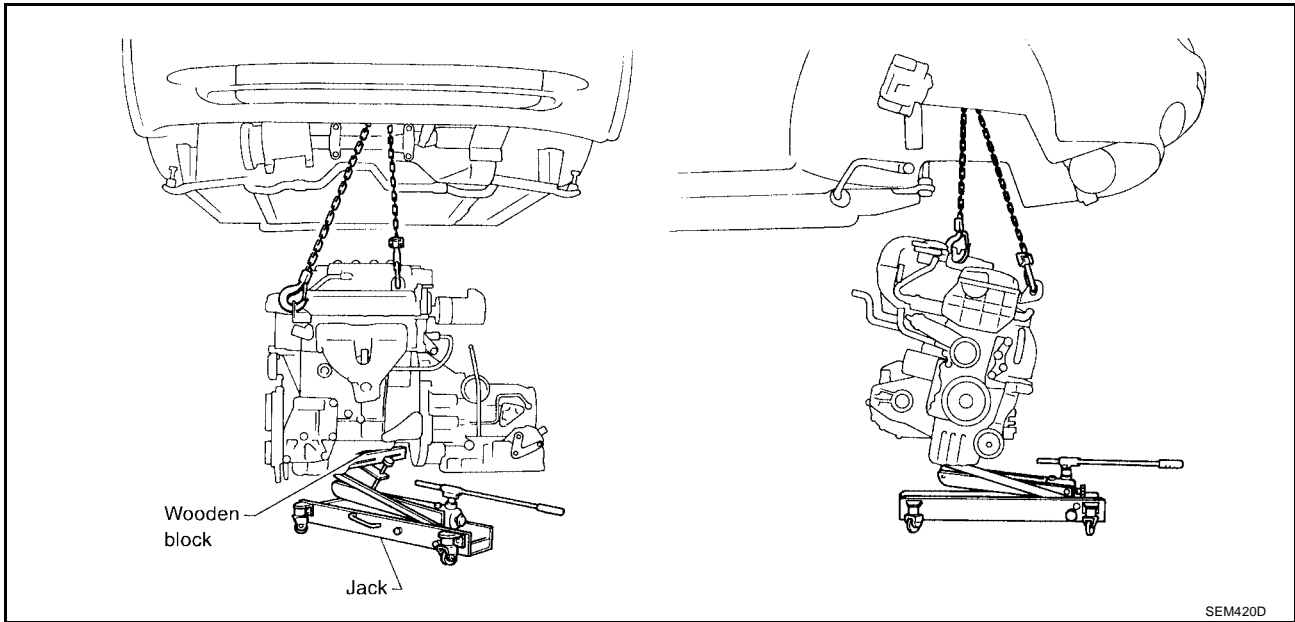

INSTALLATION

- Installation is in the reverse order of removal.

CYLINDER BLOCK

[QG18DE]

PF11010

EBS00CEU

CYLINDER BLOCK

Components

SEC. 110•120•226

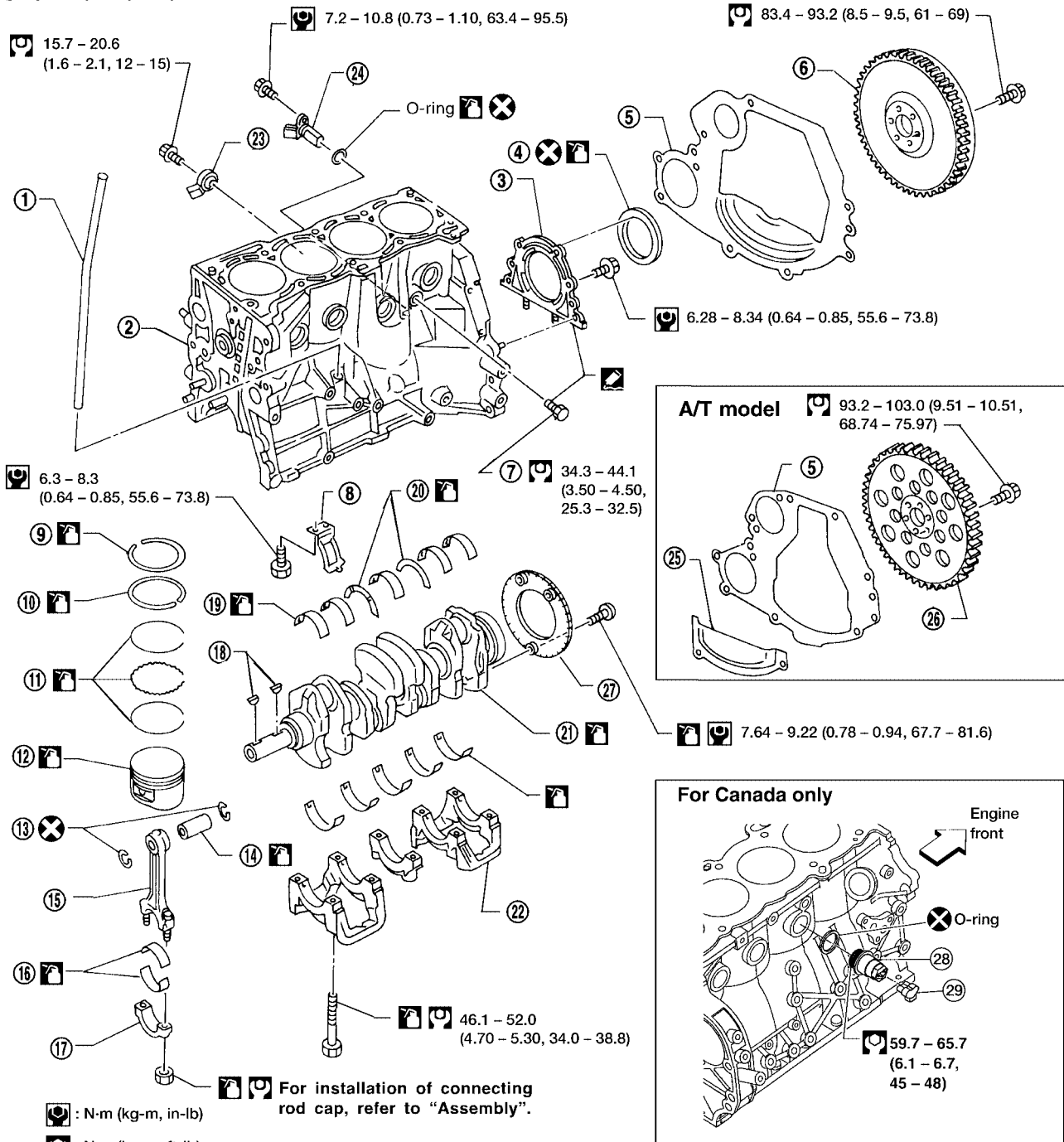

- 1. Oil level gauge guide
- 4. Rear oil seal
- 7. Drain plug
- 10. 2nd ring

- 2. Cylinder block
- 5. Rear plate
- 8. Baffle plate
- 11. Oil ring

- 3. Rear oil seal retainer
- 6. Flywheel
- 9. Top ring
- 12. Piston

WBIA0135E

- | | | |
|--------------------------------|--|--------------------------------------|
| 13. Snap ring | 14. Piston pin | 15. Connecting rod |
| 16. Connecting rod bearing | 17. Connecting rod cap | 18. Key |
| 19. Main bearing | 20. Thrust bearing | 21. Crankshaft |
| 22. Main bearing cap | 23. Knock sensor | 24. Crankshaft position sensor (POS) |
| 25. Rear lower plate | 26. Drive plate | 27. Signal plate |
| 28. Block heater (Canada only) | 29. Connector protective cap (Canada only) | |

Removal and Installation

EBS00CEV

CAUTION:

- When installing sliding parts such as bearings and pistons, apply engine oil on the sliding surfaces.
- Place removed parts, such as bearings and bearing caps, in their proper order and direction.
- When installing connecting rod nuts and main bearing cap bolts, apply new engine oil to threads and seating surfaces.
- Do not allow any magnetic materials to contact the signal plate teeth of flywheel or drive plate, and rear plate.
- Remove the crankshaft position sensor (POS).
- Be careful not to damage sensor edges and signal plate teeth.

Disassembly PISTON AND CRANKSHAFT

EBS00CEW

1. Place engine on a work stand.
2. Drain any remaining engine coolant and oil.
3. Remove timing chain. Refer to [EM-40, "Removal"](#) .

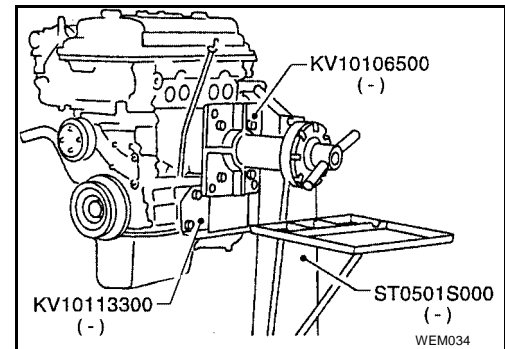

4. Remove pistons with connecting rod.
 - When disassembling piston and connecting rod, remove snap ring first. Then heat piston to 60° to 70°C (140° to 158°F) or use piston pin press stand at room temperature.

CAUTION:

- When piston rings are not replaced, make sure that piston rings are mounted in their original positions.
- When replacing piston rings, if there is no punch mark, install with either side up.

5. Measure crankshaft end play. Refer to [EM-72, "Crankshaft"](#) .

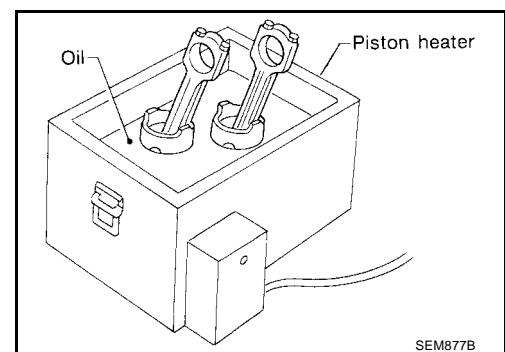

6. Loosen main bearing caps in numerical order as shown in figure.
 - Bolts should be loosened in two or three steps.
7. Remove bearing caps, main bearings and crankshaft.

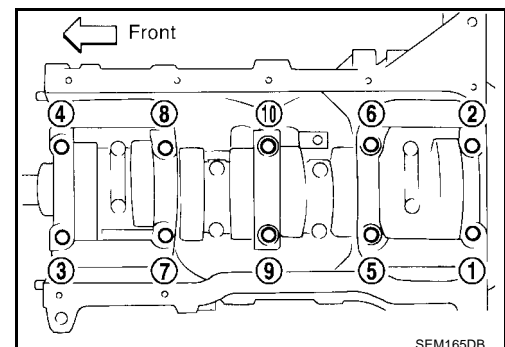

- Remove signal plate from crankshaft.

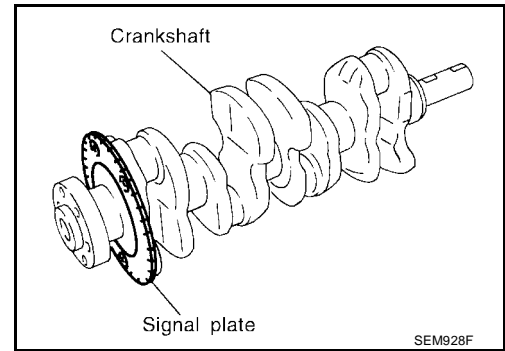

EBS00CEX

Inspection PISTON AND PISTON PIN CLEARANCE

- Measure inner diameter of piston pin hole "dp".

**Standard diameter "dp" :18.993 - 19.005 mm
(0.7478 - 0.7482 in)**

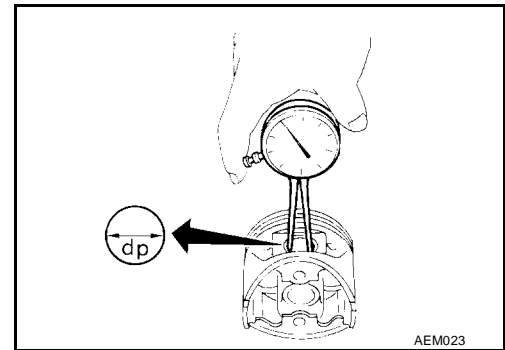

- Measure outer diameter of piston pin "Dp".

**Standard diameter "Dp" :18.989 - 19.001 mm
(0.7476 - 0.7481 in)**

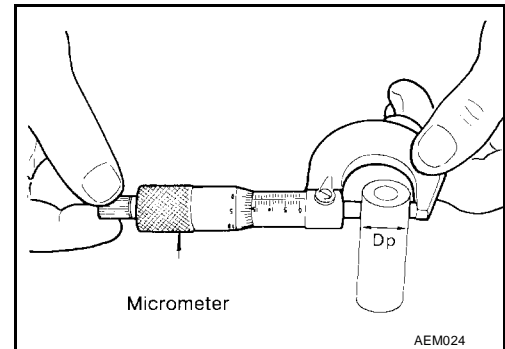

- Calculate piston pin clearance $Dp - dp$.

Piston pin to piston clearance : 0.002 - 0.006 mm (0.0001 - 0.0002 in)

If it exceeds the above value, replace piston assembly with pin.

CYLINDER BLOCK

[QG18DE]

PISTON RING SIDE CLEARANCE

Side clearance

Top ring	: 0.045 - 0.080 mm (0.0018 - 0.0031 in)
2nd ring	: 0.030 - 0.070 mm (0.0012 - 0.0028 in)
Oil ring	: 0.065 - 0.135 mm (0.0026 - 0.0053 in)
Limit	: 0.2 mm (0.008 in)

If out of specification, replace piston and/or piston ring assembly.

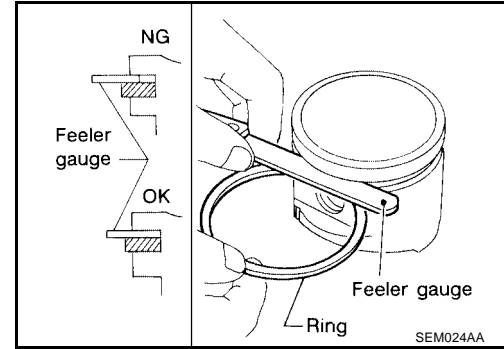

PISTON RING END GAP

End gap

Top ring	: 0.20 - 0.39 mm (0.0079 - 0.0154 in)
2nd ring	: 0.32 - 0.56 mm (0.0126 - 0.0220 in)
Oil ring	: 0.20 - 0.69 mm (0.0079 - 0.0272 in)

Limit of end gap

Top ring	: 0.49 mm (0.0193 in)
2nd ring	: 0.64 mm (0.0252 in)
Oil ring	: 1.09 mm (0.0429 in)

If out of specification, replace piston ring. If gap exceeds maximum limit with a new ring, rebore cylinder and use oversized piston and piston rings.

Refer to [EM-87, "Piston, Piston Ring and Piston Pin"](#).

- When replacing the piston, check the cylinder block surface for scratches or seizure. If scratches or seizure is found, hone or replace the cylinder block.

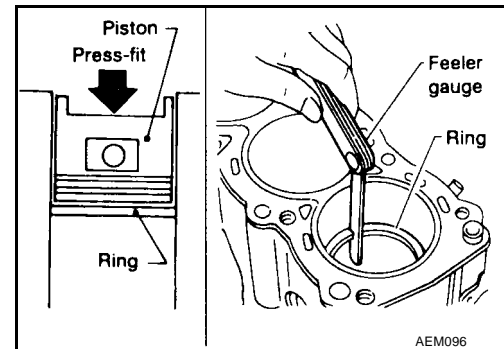

CONNECTING ROD BEND AND TORSION

Bend Limit	: 0.15 mm (0.0059 in) per 100 mm (3.94 in) length
Torsion Limit	: 0.3 mm (0.012 in) per 100 mm (3.94 in) length

If it exceeds the limit, replace connecting rod assembly.

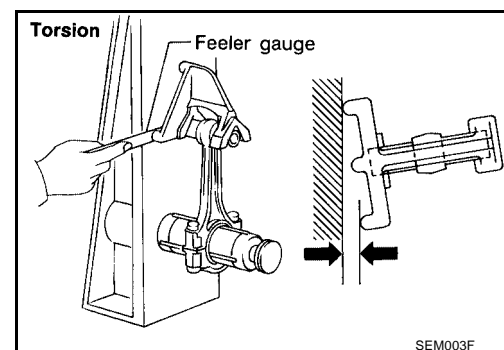
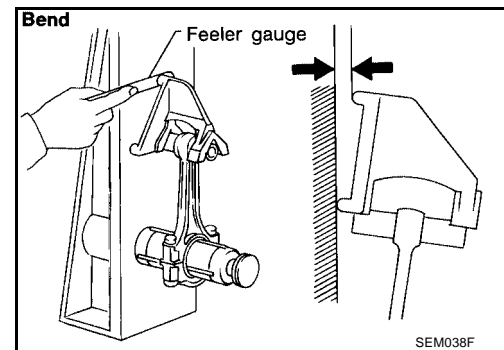

CYLINDER BLOCK DISTORTION AND WEAR

Clean upper surface of cylinder block.

Use a reliable straightedge and feeler gauge to check the flatness of cylinder block surface. Check along six positions shown in figure.

Block surface flatness

Standard : Less than 0.03 mm (0.0012 in)

Limit : 0.1 mm (0.004 in)

If out of specification, resurface it.

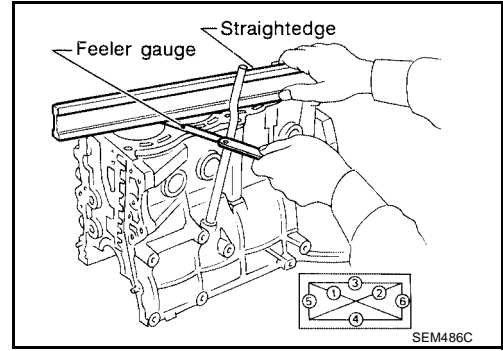

The limit for cylinder block resurfacing is determined by the amount of cylinder head resurfacing.

Amount of cylinder head resurfacing is "A".

Amount of cylinder block resurfacing is "B".

The maximum limit is as follows A + B : 0.2 mm (0.008 in)

Nominal cylinder block height from crankshaft center : 213.95 - 214.05 mm (8.4232 - 8.4271 in)

If necessary, replace cylinder block.

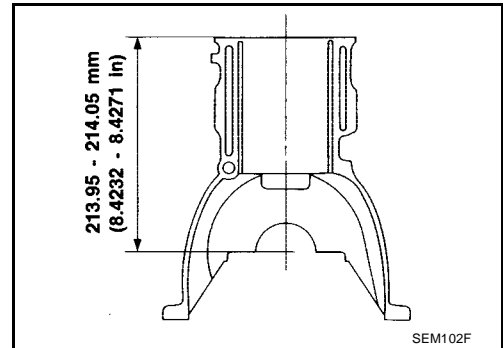

PISTON-TO-BORE CLEARANCE

1. Using a bore gauge, measure cylinder bore for wear, out-of-round and taper. The Y axis is in the longitudinal direction of the engine.

Standard inner diameter (Grade No. 1) : 80.000 - 80.010 mm (3.1496 - 3.1500 in)

Wear limit : 0.2 mm (0.008 in)

Out-of-round (X - Y) standard : Less than 0.015 mm (0.0006 in)

Taper (B - A) standard : Less than 0.01 mm (0.0004 in)

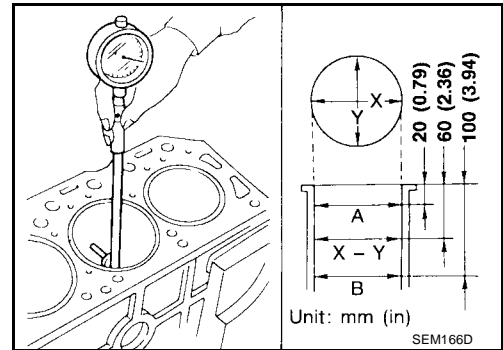

If it exceeds the limit, rebore all cylinders. Replace cylinder block if necessary.

2. Check for score and seizure. If seizure is found, hone it.

- If cylinder block or piston is replaced, match piston grade with grade number on cylinder block lower surface.

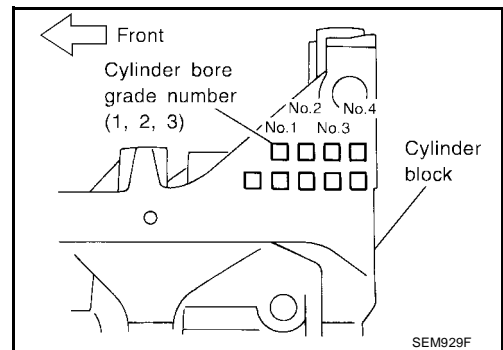

CYLINDER BLOCK

[QG18DE]

3. Measure piston skirt diameter.

Piston diameter "A" :Refer to [EM-87, "Piston, Piston Ring and Piston Pin"](#) .

Measuring point "a" :42.3 mm (1.665 in)
(Distance from the top)

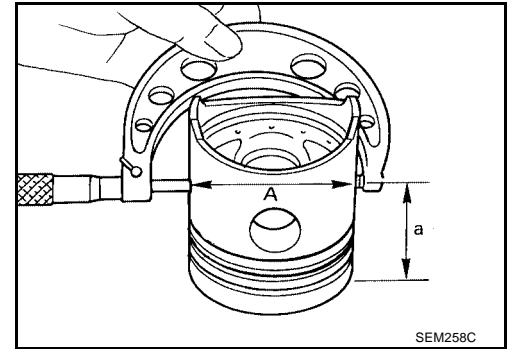

4. Check that piston-to-bore clearance is within specification.

Piston-to-bore clearance :0.025 - 0.045 mm
(0.0010 - 0.0018 in)
= cylinder bore measurement "B" – Piston diameter "A"

5. Determine piston oversize according to amount of cylinder wear.

- **Oversize pistons are available for service. Refer to [EM-87, "Piston, Piston Ring and Piston Pin"](#) .**

6. Cylinder bore size is determined by adding piston-to-bore clearance to piston diameter "A".

Rebored size calculation

$$D = A + B - C$$

where:

D : Bored diameter
A : Piston diameter as measured
B : Piston-to-bore clearance
C : Honing allowance 0.02 mm
(0.0008 in)

7. Install main bearing caps and tighten bolts to the specified torque. This will prevent distortion of cylinder bores.

8. Cut cylinder bores.

- **When any cylinder needs boring, all other cylinders must also be bored.**
- **Do not cut too much out of cylinder bore at a time. Cut only 0.05 mm (0.0020 in) or so at a time.**

- 9.hone cylinders to obtain specified piston-to-bore clearance.

10. Measure finished cylinder bore for out-of-round and taper.

- **Measurement should be done after cylinder bore cools down.**

CRANKSHAFT

1. Check crankshaft main and pin journals for score, wear or cracks.

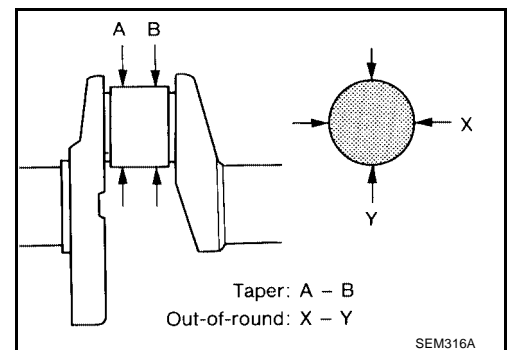

2. With a micrometer, measure journals for taper and out-of-round.

Out-of-round, (X – Y)

Standard : Less than 0.003 mm
(0.0001 in)

Limit : Less than 0.005 mm
(0.0002 in)

Taper, (A – B)

Standard : Less than 0.004 mm
(0.0002 in)

Limit : Less than 0.005 mm
(0.0002 in)

3. Measure crankshaft runout.

Runout, Standard (Total indicator reading) : Less than 0.04 mm
(0.0016 in)

Limit : Less than 0.05 mm
(0.0020 in)

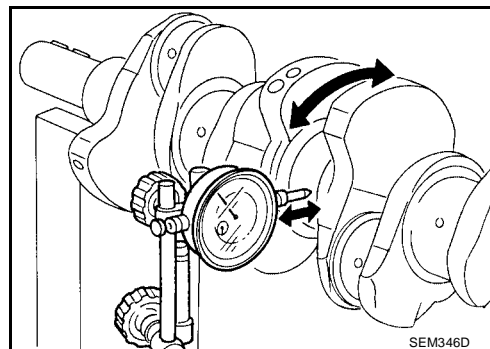

BEARING CLEARANCE

Use Method A or Method B. Method A is preferred because it is more accurate.

Method A (Using bore gauge and micrometer)

Main bearing

1. Set main bearings in their proper positions on cylinder block and main bearing cap.
2. Install main bearing cap to cylinder block.
Tighten all bolts in correct order in two or three stages. Refer to [EM-77, "Assembly"](#) .

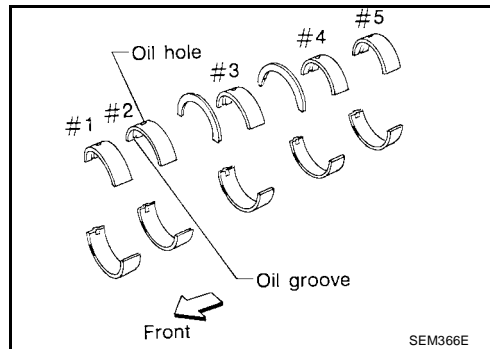

3. Measure inner diameter "A" of each main bearing.

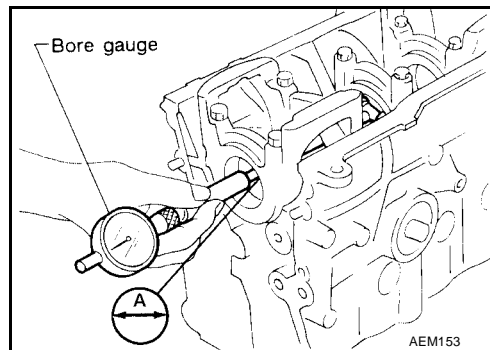

A
EM
C
D
E
F
G
H
I
J
K
L
M

CYLINDER BLOCK

[QG18DE]

4. Measure outer diameter "Dm" of each main journal in crankshaft.

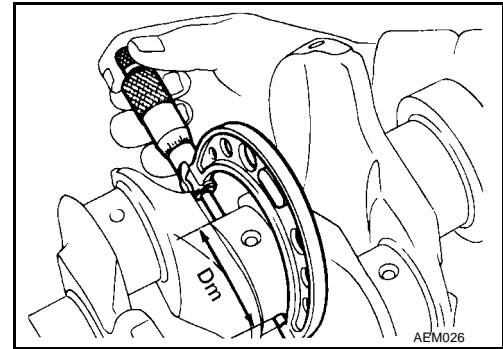

5. Calculate main bearing clearance.

Main bearing clearance = A – Dm

Standard : 0.018 - 0.042 mm (0.0007 - 0.0017 in)

Limit : 0.1 mm (0.004 in)

If it exceeds the limit, replace bearing.

If clearance cannot be adjusted within standard of any bearing, grind crankshaft journal and use undersized bearing.

When grinding crank pin and crank journal:

- Grind until clearance is within specified standard bearing clearance.
- Fillets should be finished as shown in the figure. R: 2.3 - 2.5 mm (0.091 - 0.098 in)

Refer to [EM-90, "Bearing Clearance"](#) for standard bearing clearance and available spare parts.

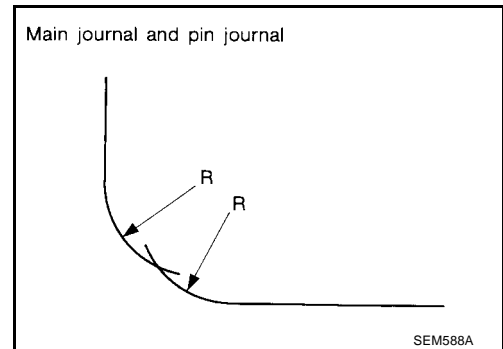

6. If the crankshaft is replaced, select thickness of main bearings as follows:

- a. Grade number of each cylinder block main journal is punched on the respective cylinder block. These numbers are punched in either Arabic or Roman numerals.
- b. Grade number of each crankshaft main journal is punched on the respective crankshaft. These numbers are punched in either Arabic or Roman numerals.

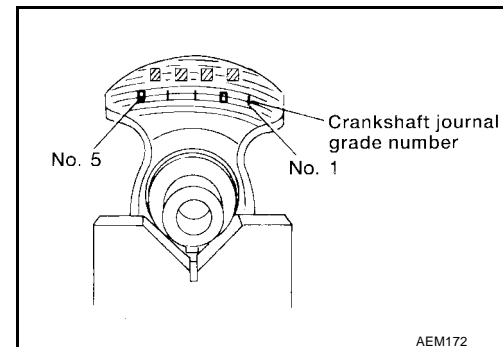
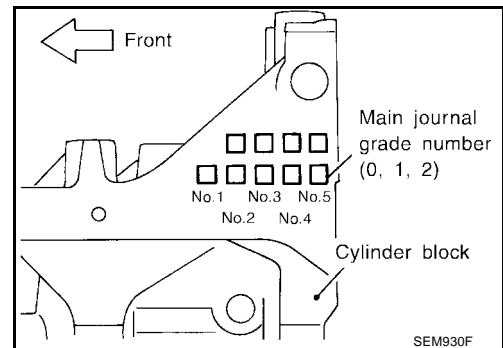

CYLINDER BLOCK

[QG18DE]

c. Select main bearing with suitable thickness according to the following table.

Main bearing grade color:

Crankshaft main journal grade number	Cylinder block main journal grade number		
	0	1 or I	2 or II
0	0 (Black)	1 (Brown)	2 (Green)
1 or I	1 (Brown)	2 (Green)	3 (Yellow)
2 or II	2 (Green)	3 (Yellow)	4 (Blue)

For example:

Cylinder block main journal grade number: 1

Crankshaft main journal grade number: 2

Main bearing grade number = 1 + 2 = 3 (Yellow)

Connecting Rod Bearing (Big End)

1. Install connecting rod bearing to connecting rod and cap.
2. Install connecting rod cap to connecting rod.

Tighten bolts to the specified torque.

3. Measure inner diameter "C" of each bearing.

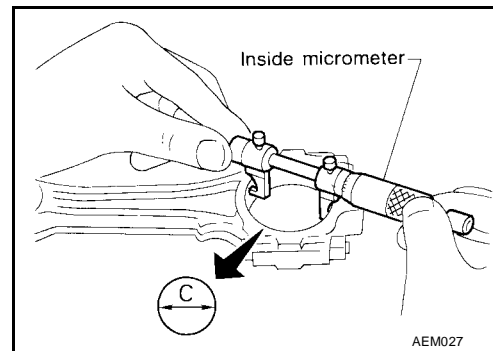
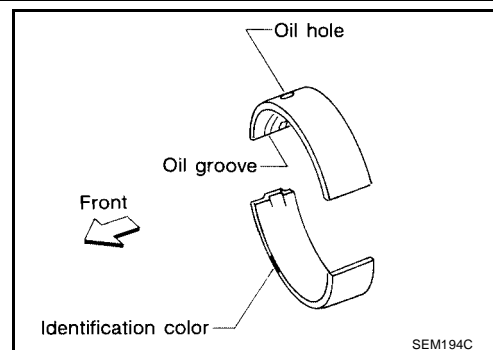

4. Measure outer diameter "Dp" of each crankshaft pin journal.
5. Calculate connecting rod bearing clearance.

Connecting rod bearing clearance = C – Dp

Standard : 0.014 - 0.039 mm (0.0006 - 0.0015 in)

Limit : 0.1 mm (0.004 in)

If it exceeds the limit, replace bearing.

If clearance cannot be adjusted using any standard bearing grade, grind crankshaft journal and use undersized bearing. Refer to [EM-90, "Bearing Clearance"](#).

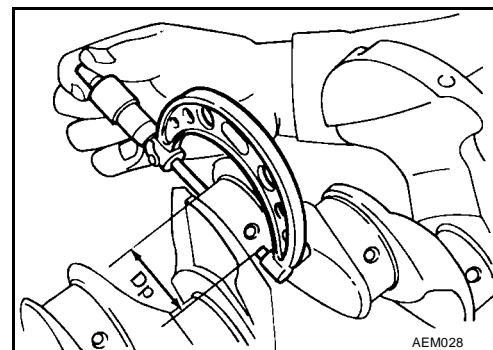

- If a new bearing, crankshaft or connecting rod is replaced, select connecting rod bearing according to the following table.

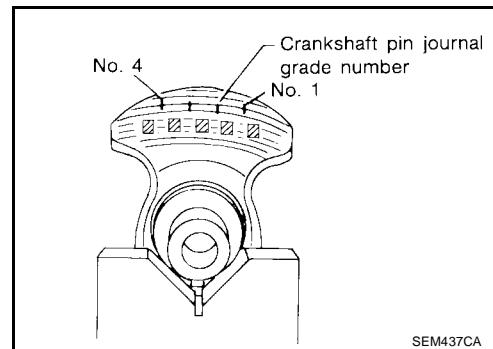

Connecting rod bearing grade number:

These numbers are punched in either Arabic or Roman numerals.

Crankshaft pin journal grade number	Connecting rod bearing grade color
0	—

CYLINDER BLOCK

[QG18DE]

Crankshaft pin journal grade number	Connecting rod bearing grade color
1 or I	Brown
2 or II	Green

Method B (Using Plastigage)

CAUTION:

- Do not turn crankshaft or connecting rod while Plastigage is being inserted.
- If incorrect bearing clearance exists, use a thicker or undersized main bearing to ensure specified clearance.

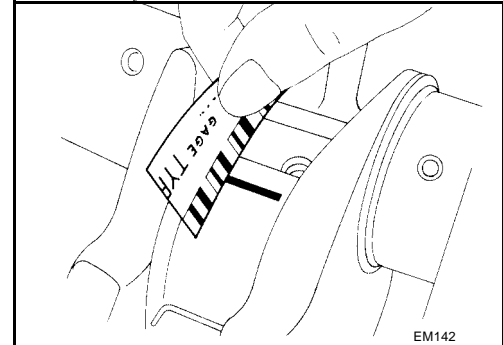

CONNECTING ROD BUSHING CLEARANCE (SMALL END)

1. Measure inner diameter "C" of bushing.

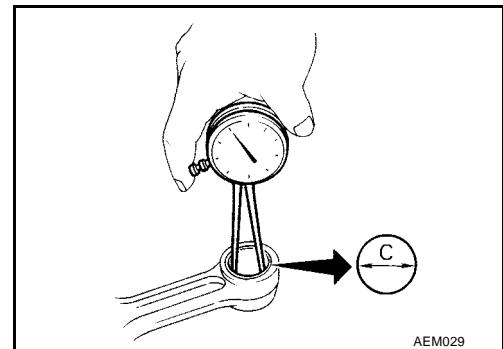

2. Measure outer diameter "Dp" of piston pin.
3. Calculate piston pin to connecting rod bushing clearance.

**Piston pin to connecting rod bushing clearance =
C – Dp**

Standard :0.005 - 0.017 mm (0.0002 - 0.0007 in)

Limit :0.023 mm (0.0009 in)

If it exceeds the limit, replace connecting rod assembly or connecting rod bushing and/or piston pin.

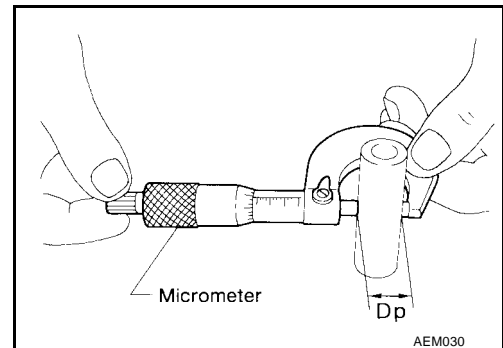

REPLACEMENT OF CONNECTING ROD BUSHING (SMALL END)

1. Drive in small end bushing until it is flush with end surface of rod.

Be sure to align the oil holes.

2. Ream the bushing so that clearance with piston pin is within specification.

Piston pin to connecting rod bushing clearance

Standard : 0.005 - 0.017 mm (0.0002 - 0.0007 in)

Limit : 0.023 mm (0.0009 in)

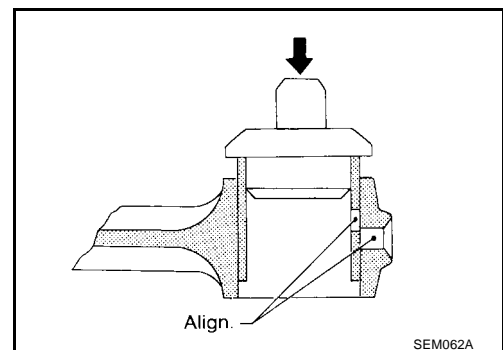

FLYWHEEL RUNOUT

Runout (Total indicator reading)

Flywheel (M/T models) :Less than 0.15 mm
(0.0059 in)

CAUTION:

- Do not allow any magnetic materials to contact the ring gear teeth and rear plate.
- Do not resurface flywheel. Replace as necessary.

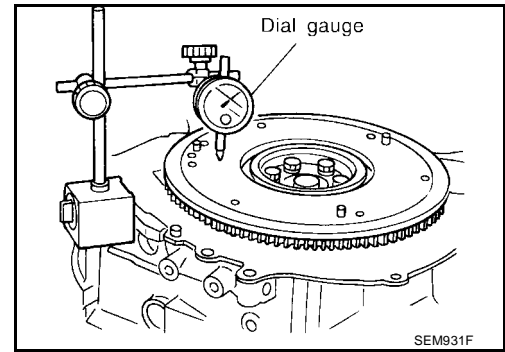

EBS00CEY

Assembly PISTON

1. Install new snap ring on one side of piston pin hole.

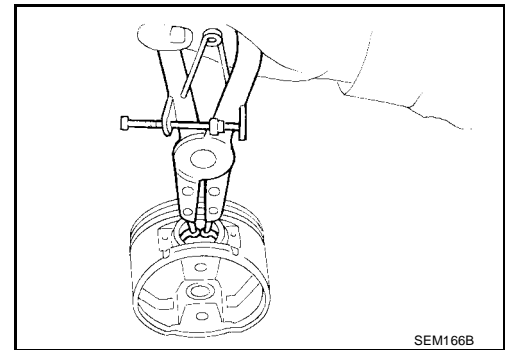

2. Heat piston to 60° to 70°C (140° to 158°F) and assemble piston, piston pin, connecting rod and new snap ring.

- Align the direction of piston and connecting rod.
- Numbers stamped on connecting rod and cap correspond to each cylinder.
- After assembly, make sure connecting rod swings smoothly.

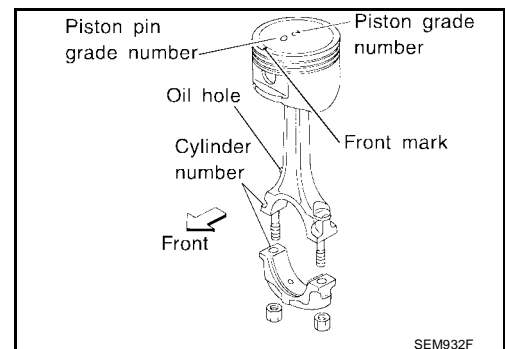

3. Set piston rings as shown.

CAUTION:

- When piston rings are not replaced, make sure that piston rings are mounted in their original position.
- Install new piston rings either side up if there is no punch mark.

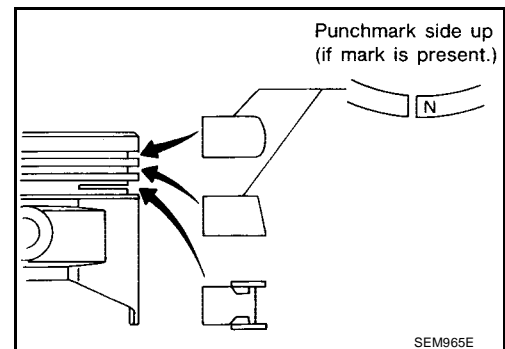

A
EM
C
D
E
F
G
H
I
J
K
L
M

CYLINDER BLOCK

[QG18DE]

- Align piston rings so that end gaps are positioned as shown.

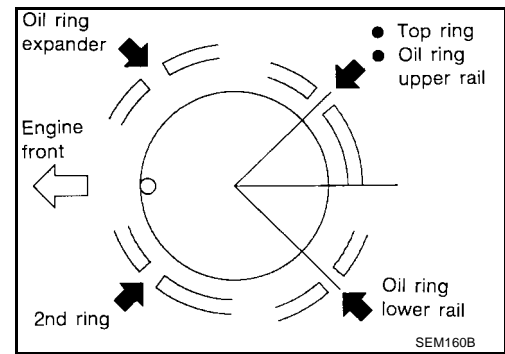

CRANKSHAFT

1. Install signal plate to crankshaft using dowel pin to properly position the signal plate. Remove the dowel pin after the signal plate bolts are tightened. Tighten the signal plate bolts.

Signal plate bolts : 7.64 - 9.22 N·m (0.78 - 0.94 kg·m, 67.7 - 81.6 in·lb)

Dowel pin diameter : 6 mm (0.24 in)

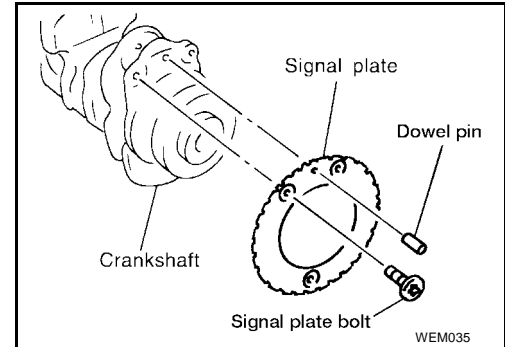

2. Set main bearings in their proper positions on cylinder block and main bearing cap.

- Confirm that correct main bearings are selected by using **Method A** or **Method B**. Refer to **EM-90, "Bearing Clearance"**.
- Apply new engine oil to bearing surfaces.

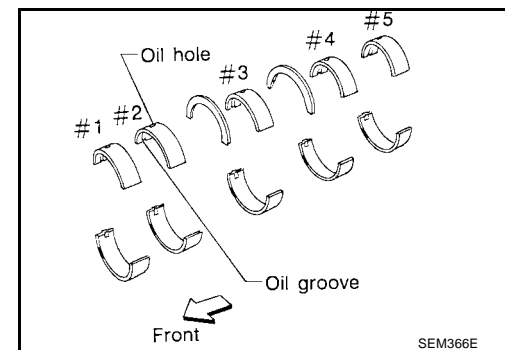
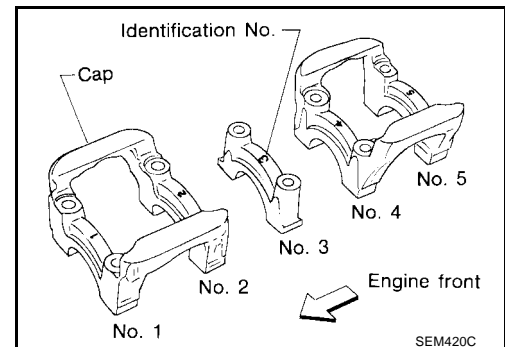

CYLINDER BLOCK

[QG18DE]

3. Install crankshaft and main bearing caps and tighten bolts to the specified torque.
 - Apply new engine oil to the bolt thread and seat surface.
 - Prior to tightening bearing cap bolts, shift crankshaft back and forth to properly seat the bearing caps.
 - Tighten bearing cap bolts gradually in two or three stages. Start with center bearing and move outward as shown in figure.
 - After securing bearing cap bolts, make sure crankshaft turns smoothly by hand.

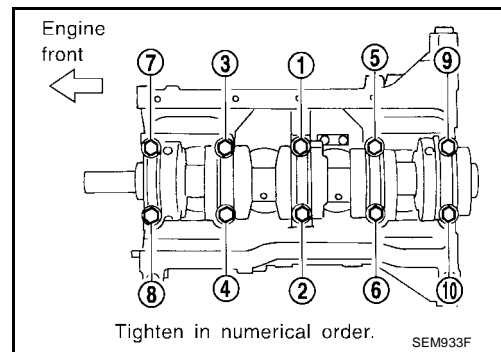

4. Measure crankshaft free end play.

Crankshaft free end play

Standard 0.060 - 0.220 mm (0.0024 - 0.0087 in)

Limit 0.3 mm (0.012 in)

If beyond the limit, replace thrust bearing with new ones.

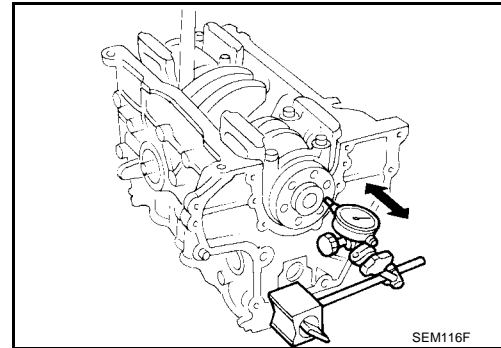

5. Install connecting rod bearings in connecting rods and connecting rod caps.
 - Confirm that correct bearings are used. Refer to [EM-90, "Connecting Rod Bearing"](#).
 - Install bearings so that oil hole in connecting rod aligns with oil hole of bearing.
 - Apply new engine oil to bolt threads and bearing surfaces.

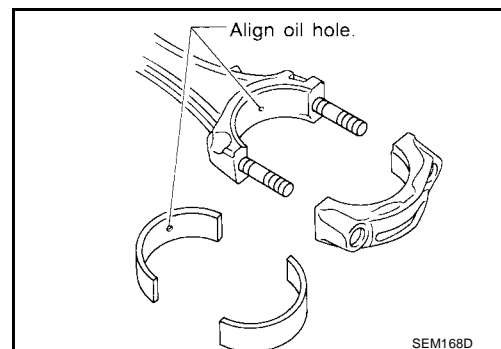

6. Install pistons with connecting rods.
 - a. Install them into corresponding cylinders with Tool.
 - Make sure connecting rod does not scratch cylinder wall.
 - Make sure connecting rod bolts do not scratch crankshaft pin journals.
 - Arrange so that front mark on piston head faces engine.
 - Apply new engine oil to piston rings and sliding surface of piston.

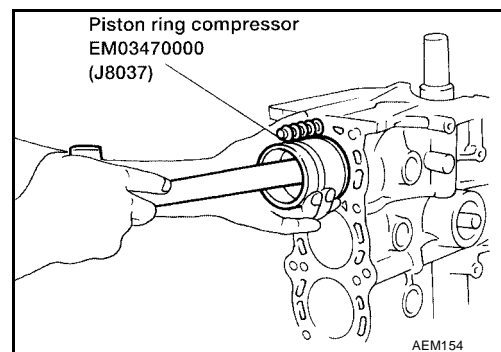

CYLINDER BLOCK

[QG18DE]

- b. Install connecting rod caps.
Apply new engine oil to bolt threads and nut seating surfaces.
Tighten connecting rod cap nuts in two stages:

**Stage 1 : 13.72 - 15.68 N·m (1.399 - 1.599 kg-m,
10.120 - 11.566 ft-lb)**

**Stage 2 : 35 - 40 degrees clockwise, or 23 - 28 N·m
(2.3 - 2.9 kg-m, 17 - 21 ft-lb)**

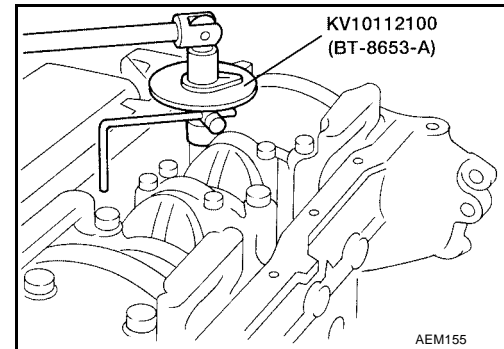

7. Measure connecting rod side clearance.

Connecting rod side clearance

Standard : 0.200 - 0.470 mm (0.0079 - 0.0185 in)

Limit : 0.52 mm (0.0205 in)

If beyond the limit, replace connecting rod and/or crankshaft.

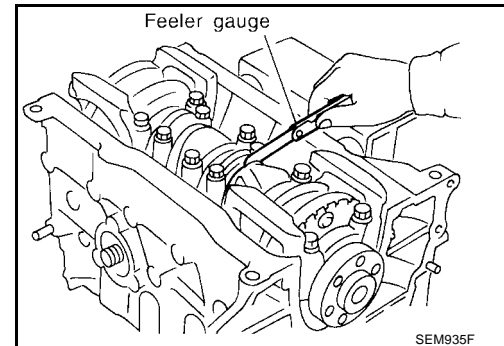

8. Install rear oil seal retainer.

- a. Before installing rear oil seal retainer, remove old Silicone RTV Sealant from cylinder block and retainer.

- b. Apply a continuous bead of Silicone RTV Sealant to rear oil seal retainer.

● **Use Genuine Silicone RTV Sealant, or equivalent. Refer to [GI-44. "RECOMMENDED CHEMICAL PRODUCTS AND SEALANTS"](#).**

● **Apply around inner side of bolt holes.**

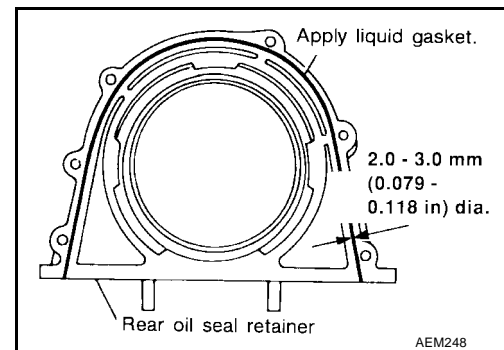

9. Install crankshaft position sensor (POS).

Crankshaft position sensor bolt : 7.2 - 10.8 N·m (0.73 - 1.10 kg-m, 63.4 - 95.5 in-lb)

10. Install knock sensor at correct angle.

**Knock sensor bolt : 15.7 - 20.6 N·m (1.6 - 2.1 kg-m,
12 - 15 ft-lb)**

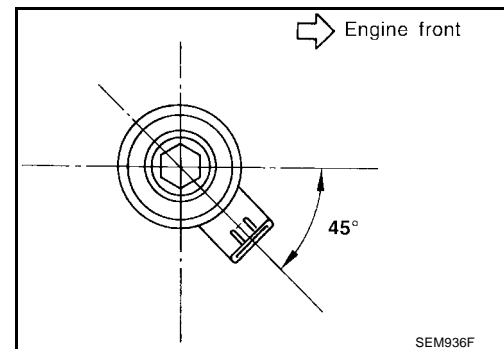

SERVICE DATA AND SPECIFICATIONS (SDS)

[QG18DE]

SERVICE DATA AND SPECIFICATIONS (SDS)

PF0:00030

General Specifications

EBS00CEZ

Engine		QG18DE
Classification		Gasoline
Cylinder arrangement		4, in-line
Displacement cm ³ (cu in)		1,769 (107.94)
Bore × stroke mm (in)		80.0 x 88.0 (3.150 x 3.465)
Valve arrangement		DOHC
Firing order		1-3-4-2
Number of piston rings	Compression	2
	Oil	1
Number of main bearings		5
Compression ratio		9.5

Valve timing
(Intake valve timing control - OFF)

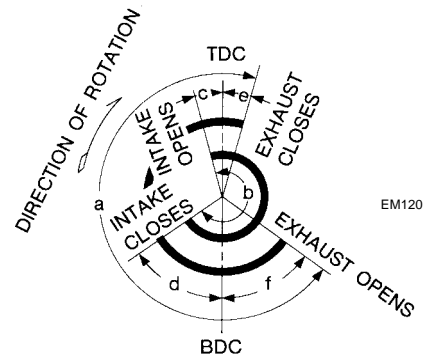

	a	b	c	d	e	f	Unit: degree
	204	236	5	51	-2	26	

Compression Pressure

EBS00CF0

Unit: kPa (kg/cm², psi)/350 rpm

Standard	1,324 (13.5, 192)
Minimum	1,157 (11.5, 168)
Difference limit between cylinders	98 (1.0, 14)

Cylinder Head

EBS00CF1

Unit: mm (in)

	Standard	Limit
Head surface flatness	Less than 0.03 (0.0012)	0.1 (0.004)
Nominal height	117.8 - 118.0 (4.638 - 4.646)	—

SERVICE DATA AND SPECIFICATIONS (SDS)

[QG18DE]

EBS00CF2

Valve VALVE

Unit: mm (in)

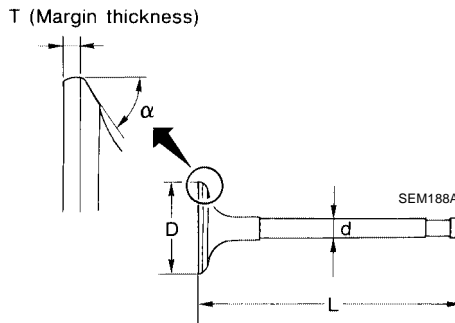

Valve head diameter "D"	Intake	29.9 - 30.2 (1.177 - 1.189)
	Exhaust	24.9 - 25.2 (0.980 - 0.992)
Valve length "L"	Intake	92.00 - 92.50 (3.6220 - 3.6417)
	Exhaust	92.37 - 92.87 (3.6366 - 3.6563)
Valve stem diameter "d"	Intake	5.465 - 5.480 (0.2152 - 0.2157)
	Exhaust	5.445 - 5.460 (0.2144 - 0.2150)
Valve face angle "α"		45°15' - 45°45'
Valve face contact width	Intake	1.06 - 1.34 (0.0417 - 0.0528)
	Exhaust	1.34 - 1.63 (0.0528 - 0.0642)
Valve margin "T" limit		1.05 - 1.35 (0.0413 - 0.0531)
Valve stem end surface grinding limit		0.2 (0.008)

VALVE SPRING

Free height mm (in)		41.19 (1.622)
Pressure N (kg, lb) at height mm (in)	Standard	370.0 (37.73, 83.19) at 23.64 (0.9307)
	Limit	More than 347.8 (35.46, 78.19) at 23.64 (0.9307)
Out-of-square mm (in)		Less than 1.75 (0.0689)

VALVE LIFTER

Unit: mm (in)

Valve lifter outer diameter	29.960 - 29.975 (1.1795 - 1.1801)
Valve lifter guide bore	30.000 - 30.021 (1.1811 - 1.1819)
Clearance between valve lifter and valve lifter guide	0.025 - 0.065 (0.0010 - 0.0026)

VALVE CLEARANCE

Unit: mm (in)

	For adjusting (Standard)		For checking (Reference)
	Hot	Cold* (reference data)	Hot
Intake	0.32 - 0.40 (0.013 - 0.016)	0.25 - 0.33 (0.010 - 0.013)	0.21 - 0.47 (0.008 - 0.019)
Exhaust	0.37 - 0.45 (0.015 - 0.018)	0.32 - 0.40 (0.013 - 0.016)	0.30 - 0.56 (0.012 - 0.022)

*: At a temperature of approximately 20°C (68°F)

Whenever valve clearances are adjusted to cold specifications, check that the clearances satisfy hot specifications and adjust again if necessary.

SERVICE DATA AND SPECIFICATIONS (SDS)

[QG18DE]

VALVE GUIDE

Unit: mm (in)

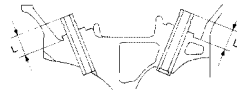

MEM096A

		Intake		Exhaust	
		Standard	Service	Standard	Service
Valve guide	Outer diameter	9.523 - 9.534 (0.3749 - 0.3754)	9.723 - 9.734 (0.3828 - 0.3832)	9.523 - 9.534 (0.3749 - 0.3754)	9.723 - 9.734 (0.3828 - 0.3832)
	Inner diameter [Finished size]	5.500 - 5.515 (0.2165 - 0.2171)		5.500 - 5.515 (0.2165 - 0.2171)	
Cylinder head valve guide hole diameter		9.475 - 9.496 (0.3730 - 0.3739)	9.685 - 9.696 (0.3813 - 0.3817)	9.475 - 9.496 (0.3730 - 0.3739)	9.685 - 9.696 (0.3813 - 0.3817)
Interference fit of valve guide		0.027 - 0.059 (0.0011 - 0.0023)	0.027 - 0.049 (0.0011 - 0.0019)	0.027 - 0.059 (0.0011 - 0.0023)	0.027 - 0.049 (0.0011 - 0.0019)
Stem to guide clearance		0.020 - 0.050 (0.0008 - 0.0020)		0.040 - 0.070 (0.0016 - 0.0028)	
Stem to guide clearance limit		0.1 (0.004)		0.1 (0.004)	
Valve deflection limit (Dial gauge reading)		0.2 (0.008)			
Projection length "L"		11.5 - 11.7 (0.453 - 0.461)			

AVAILABLE SHIMS

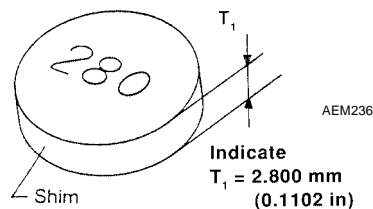

Thickness mm (in)	Identification mark
2.00 (0.0787)	200
2.02 (0.0795)	202
2.04 (0.0803)	204
2.06 (0.0811)	206
2.08 (0.0819)	208
2.10 (0.0827)	210
2.12 (0.0835)	212
2.14 (0.0843)	214
2.16 (0.0850)	216
2.18 (0.0858)	218
2.20 (0.0866)	220

SERVICE DATA AND SPECIFICATIONS (SDS)

[QG18DE]

2.21 (0.0870)	221
2.22 (0.0874)	222
2.23 (0.0877)	223
2.24 (0.0882)	224
2.25 (0.0885)	225
2.26 (0.0890)	226
2.27 (0.0893)	227
2.28 (0.0898)	228
2.29 (0.0901)	229
2.30 (0.0906)	230
2.31 (0.0909)	231
2.32 (0.0913)	232
2.33 (0.0917)	233
2.34 (0.0921)	234
2.35 (0.0925)	235
2.36 (0.0929)	236
2.37 (0.0933)	237
2.38 (0.0937)	238
2.39 (0.0940)	239
2.40 (0.0945)	240
2.41 (0.0948)	241
2.42 (0.0953)	242
2.43 (0.0956)	243
2.44 (0.0961)	244
2.45 (0.0964)	245
2.46 (0.0969)	246
2.47 (0.0972)	247
2.48 (0.0976)	248
2.49 (0.0980)	249
2.50 (0.0984)	250
2.51 (0.0988)	251
2.52 (0.0992)	252
2.53 (0.0996)	253
2.54 (0.1000)	254
2.55 (0.1003)	255
2.56 (0.1008)	256
2.57 (0.1011)	257
2.58 (0.1016)	258
2.59 (0.1019)	259
2.60 (0.1024)	260
2.61 (0.1027)	261
2.62 (0.1031)	262
2.63 (0.1035)	263
2.64 (0.1039)	264
2.65 (0.1043)	265

SERVICE DATA AND SPECIFICATIONS (SDS)

[QG18DE]

2.66 (0.1047)	266
2.68 (0.1055)	268
2.70 (0.1063)	270
2.72 (0.1071)	272
2.74 (0.1079)	274
2.76 (0.1087)	276
2.78 (0.1094)	278
2.80 (0.1102)	280
2.82 (0.1110)	282
2.84 (0.1118)	284
2.86 (0.1126)	286
2.88 (0.1134)	288
2.90 (0.1142)	290
2.92 (0.1150)	292
2.94 (0.1157)	294
2.96 (0.1165)	296
2.98 (0.1173)	298

A
EM
C
D
E
F
G

VALVE SEAT

Unit: mm (in)

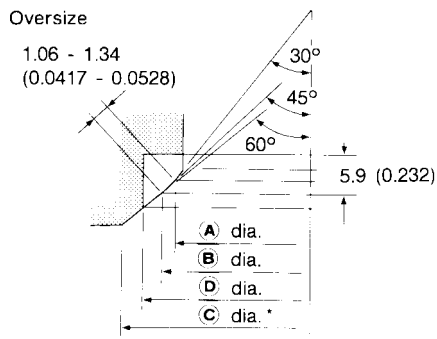
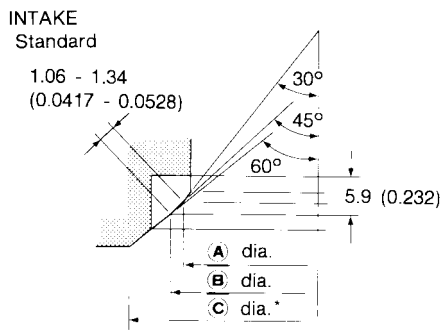

* Cylinder head machining data SEM573DA

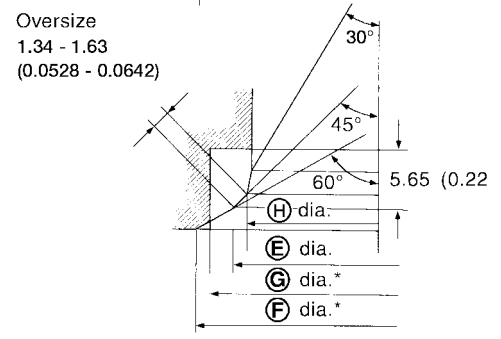
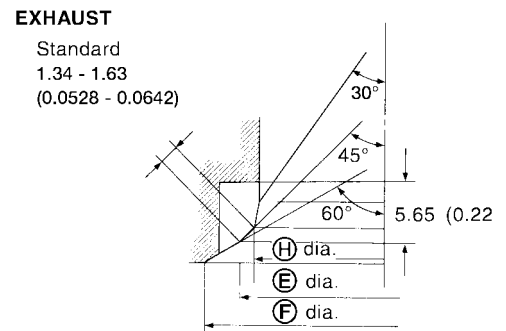

* Cylinder head machining data SEM047

H
I
J
K
L
M

Dia.	Specification	Dia.	Specification
A	27.8 - 28.0 (1.094 - 1.102)	E	24.5 - 24.7 (0.965 - 0.972)
B	29.5 - 29.7 (1.161 - 1.169)	F	26.500 - 26.516 (1.0433 - 1.0439)
C	31.9 - 32.1 (1.256 - 1.264)	G	26.2 - 26.4 (1.031 - 1.039)
D	31.500 - 31.516 (1.2402 - 1.2408)	H	22.4 - 22.6 (0.8819 - 0.8898)

SERVICE DATA AND SPECIFICATIONS (SDS)

[QG18DE]

VALVE SEAT RESURFACE LIMIT

Unit: mm (in)

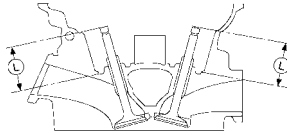

AEM343

Depth (L)	Intake	35.95 - 36.55 (1.4154 - 1.4390)
	Exhaust	35.92 - 36.52 (1.4142 - 1.4378)

Camshaft and Camshaft Bearing

EBS00CF3

Unit: mm (in)

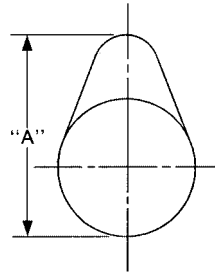

SEM671

Cam height "A"	Intake	40.61 - 40.80 (1.599 - 1.606)	
	Exhaust	38.965 - 39.155 (1.534 - 1.542)	
Cam wear limit		0.20 (0.0079)	
		Standard	Limit
Camshaft journal clearance		Intake: 0.030 - 0.071 (0.0012 - 0.0028) Exhaust: 0.045 - 0.086 (0.0018 - 0.0034)	Intake: 0.135 (0.0053) Exhaust: 0.150 (0.0059)
Inner diameter of camshaft bracket	No. 1	28.000 - 28.021 (1.1024 - 1.1032)	—
	No. 2, 3, 4, 5	Intake: 23.985 - 24.006 (0.9443 - 0.9451) Exhaust: 24.000 - 24.021 (0.9449 - 0.9457)	
Outer diameter of camshaft journal	No. 1	27.935 - 27.955 (1.0998 - 1.1006)	—
	No. 2, 3, 4, 5	23.935 - 23.955 (0.9423 - 0.9431)	
Camshaft runout [TIR*]		Less than 0.02 (0.0008)	0.1 (0.004)
Camshaft sprocket runout [TIR*]		Less than 0.15 (0.0059)	
Camshaft end play		0.115 - 0.188 (0.0045 - 0.0074)	0.20 (0.0079)

*Total indicator reading

SERVICE DATA AND SPECIFICATIONS (SDS)

[QG18DE]

Cylinder Block

EBS00CF4

Unit: mm (in)

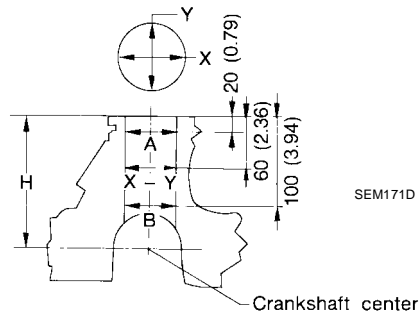

		Standard	Limit
Surface flatness		Less than 0.03 (0.0012)	0.1 (0.004)
Height "H" (nominal)		213.95 - 214.05 (8.4232 - 8.4271)	—
Cylinder bore inner diameter	Standard	Grade No. 1 80.000 - 80.010 (3.1496 - 3.1500)	0.2 (0.008)
		Grade No. 2 80.010 - 80.020 (3.1500 - 3.1504)	
		Grade No. 3 80.020 - 80.030 (3.1504 - 3.1508)	
Out-of-round (X - Y)		Less than 0.015 (0.0006)	—
Taper (B - A)		Less than 0.01 (0.0004)	—
Difference in inner diameter between cylinders		0.05 (0.0020)	0.2 (0.008)

Piston, Piston Ring and Piston Pin PISTON

EBS00CF5

Unit: mm (in)

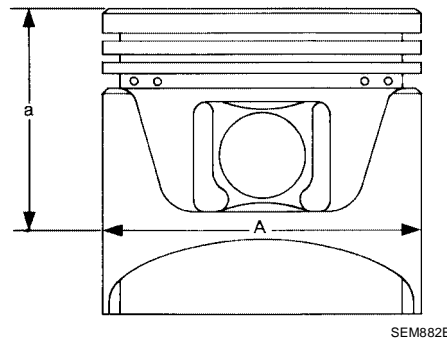

Piston skirt diameter "A"	Standard	Grade No. 1	79.965 - 79.975 (3.1482 - 3.1486)
		Grade No. 2	79.975 - 79.985 (3.1486 - 3.1490)
		Grade No. 3	79.985 - 79.995 (3.1490 - 3.1494)
	0.25 (0.0098) oversize (service)		80.215 - 80.245 (3.1581 - 3.1592)
	0.5 (0.020) oversize (service)		80.465 - 80.495 (3.1679 - 3.1691)
"a" distance from the top			42.3 (1.665)
Piston pin hole inner diameter			18.993 - 19.005 (0.7478 - 0.7482)
Piston-to-bore clearance			0.025 - 0.045 (0.0010 - 0.0018)

SERVICE DATA AND SPECIFICATIONS (SDS)

[QG18DE]

PISTON RING

Unit: mm (in)

		Standard	Limit
Side clearance	Top	0.045 - 0.080 (0.0018 - 0.0031)	0.2 (0.008)
	2nd	0.030 - 0.070 (0.0012 - 0.0028)	
	Oil	0.065 - 0.135 (0.0026 - 0.0053)	
End gap	Top	0.20 - 0.39 (0.0079 - 0.0154)	0.49 (0.0193)
	2nd	0.32 - 0.56 (0.0126 - 0.0220)	0.64 (0.0252)
	Oil	0.20 - 0.69 (0.0079 - 0.0272)	1.09 (0.0429)

PISTON PIN

Unit: mm (in)

Piston pin outer diameter		18.989 - 19.001 (0.7476 - 0.7481)
Piston pin to piston clearance		0.002 - 0.006 (0.0001 - 0.0002)
Piston pin to connecting rod bushing clearance (small end)	Standard	0.005 - 0.017 (0.0002 - 0.0007)
	Limit	0.023 (0.0009)

Connecting Rod

EBS00CF6

Unit: mm (in)

Center distance		140.45 - 140.55 (5.5295 - 5.5335)
Bend limit [per 100 (3.94) length]		0.15 (0.0059)
Torsion limit [per 100 (3.94) length]		0.3 (0.012)
Connecting rod bushing inner diameter* (small end)		19.000 - 19.012 (0.7480 - 0.7485)
Connecting rod big end inner diameter		43.000 - 43.013 (1.6929 - 1.6934)
Side clearance	Standard	0.200 - 0.470 (0.0079 - 0.0185)
	Limit	0.52 (0.0205)

*After installing in connecting rod

Crankshaft

EBS00CF7

Unit: mm (in)

Out-of-round (X) - (Y)
Taper (A) - (B)

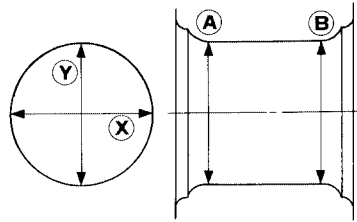

SEM715

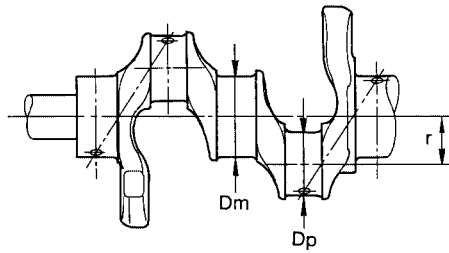

SEM645

Main journal dia. "Dm"	Grade No. 0	49.956 - 49.964 (1.9668 - 1.9671)
	Grade No. 1	49.948 - 49.956 (1.9665 - 1.9668)
	Grade No. 2	49.940 - 49.948 (1.9661 - 1.9665)
Pin journal dia. "Dp"	Grade No. 0	39.968 - 39.974 (1.5735 - 1.5738)
	Grade No. 1	39.962 - 39.968 (1.5733 - 1.5735)
	Grade No. 2	39.956 - 39.962 (1.5731 - 1.5733)
Center distance "r"		43.95 - 44.05 (1.7303 - 1.7342)
Out-of-round (X - Y)	Standard	Less than 0.003 (0.0001)
	Limit	Less than 0.005 (0.0002)
Taper (A - B)	Standard	Less than 0.004 (0.0002)
	Limit	Less than 0.005 (0.0002)
Runout [TIR*]	Standard	Less than 0.04 (0.0016)
	Limit	Less than 0.05 (0.0020)
Free end play	Standard	0.060 - 0.220 (0.0024 - 0.0087)
	Limit	0.3 (0.012)

*: Total indicator reading

SERVICE DATA AND SPECIFICATIONS (SDS)

[QG18DE]

Main Bearing STANDARD

EBS00CF8

Grade No.	Thickness "T" mm (in)	Identification color
0	1.827 - 1.831 (0.0719 - 0.0720)	Black
1	1.831 - 1.835 (0.0720 - 0.0722)	Brown
2	1.835 - 1.839 (0.0722 - 0.0724)	Green
3	1.839 - 1.843 (0.0724 - 0.0725)	Yellow
4	1.843 - 1.847 (0.0725 - 0.0727)	Blue

UNDERSIZE

Unit: mm (in)

	Thickness "T"
0.25 (0.0098)	1.960 - 1.964 (0.0772 - 0.0773)
0.50 (0.0197)	2.085 - 2.089 (0.0821 - 0.0822)

Connecting Rod Bearing STANDARD SIZE

EBS00CF9

Unit: mm (in)

Grade No.	Thickness	Identification color or number
0	1.503 - 1.506 (0.0592 - 0.0593)	—
1	1.506 - 1.509 (0.0593 - 0.0594)	Brown
2	1.509 - 1.512 (0.0594 - 0.0595)	Green

UNDERSIZE

Unit: mm (in)

Grade No.	Thickness	Identification color or number
0.08 (0.0031)	1.542 - 1.546 (0.0607 - 0.0609)	—
0.12 (0.0047)	1.562 - 1.566 (0.0615 - 0.0617)	—
0.25 (0.0098)	1.627 - 1.631 (0.0641 - 0.0642)	—

Bearing Clearance

EBS00CFA

Unit: mm (in)

Main bearing clearance	Standard	0.018 - 0.042 (0.0007 - 0.0017)
	Limit	0.1 (0.004)
Connecting rod bearing clearance	Standard	0.014 - 0.039 (0.0006 - 0.0015)
	Limit	0.1 (0.004)

Miscellaneous Components

EBS00CFB

Unit: mm (in)

Flywheel runout [TIR*]	Less than 0.15 (0.0059)
Camshaft sprocket runout [TIR*]	Less than 0.15 (0.0059)

*: Total indicator reading at measuring point 115 mm (4.53 in) from crankshaft center.

PRECAUTIONS

PFP:00001

Precautions for Draining Coolant

EBS00CFC

- Drain coolant when engine is cooled.

Precautions for Disconnecting Fuel Piping

EBS00CFD

- Before starting work, make sure no fire or spark producing items are in the work area.
- Release fuel pressure before any removal or disassembly.
- After disconnecting pipes, plug openings to stop fuel leakage.

Precautions for Removal and Disassembly

EBS00CFE

- When instructed to use special service tools, use the specified tools. Always be careful to work safely, avoid forceful operations.
- Use maximum care to avoid damage to mating or sliding surfaces.
- Cover openings of engine system with tape or equivalent, if necessary, to seal out foreign materials.
- Mark and arrange disassembly parts in an organized way for easy troubleshooting and assembly.
- When loosening nuts and bolts, as a basic rule, start with the one furthest outside, then the one diagonally opposite, and so on. If the order of loosening is specified, follow the specifications.

Precautions for Inspection, Repair and Replacement

EBS00CFF

- Before repairing or replacing, thoroughly inspect parts. Inspect new replacement parts in the same way, and replace if necessary.

Precautions for Assembly and Installation

EBS00CFG

- Use torque wrench to tighten bolts or nuts.
- When tightening nuts and bolts, as a basic rule, equally tighten in several different steps starting with the ones in center, then ones on inside and outside diagonally in this order. If the order of tightening is specified, follow the specifications.
- Always replace the old with a new gasket, packing, oil seal or O-ring.
- Thoroughly wash, clean, and air-blow each part. Carefully check oil or coolant passages for any restriction and blockage.
- Avoid damaging sliding or mating surfaces. Completely remove foreign materials such as cloth lint or dust. Before assembly, oil sliding surfaces well.
- Bleed the air trapped within the system after draining the coolant.
- Before starting engine, apply fuel pressure to fuel lines with turning ignition switch ON (with engine stopped). Then make sure that there are no leaks at fuel line connections.
- After repairing, start engine and increase engine speed to check coolant, fuel, oil, and exhaust systems for leakage or rattles.

Parts Requiring Angular Tightening

EBS00CFH

- Use an angle wrench for the final tightening of the following engine parts.
 - Cylinder head bolts
 - Lower cylinder block bolts
 - Connecting rod cap bolts
 - Crankshaft pulley bolt (No angle wrench is required as the bolt flange is provided with notches for angular tightening)
- Do not use a torque value for final tightening.
- The torque value for these parts are for a preliminary step.
- Ensure thread and seat surfaces are clean and coated with engine oil.

PRECAUTIONS

[QR25DE]

EBS00EZ4

Precautions for Liquid Gasket REMOVAL OF LIQUID GASKET SEALING

- After removing the mounting bolts and nuts, separate the mating surface using a seal cutter and remove the liquid gasket sealing.

CAUTION:

Be careful not to damage the mating surfaces.

- In areas where the cutter is difficult to use, use a plastic hammer to lightly tap (1) the cutter where the Silicone RTV Sealant is applied. Use a plastic hammer to slide the cutter (2) by tapping on the side.

CAUTION:

If for some unavoidable reason a tool such as a flat-bladed screwdriver is used, be careful not to damage the mating surfaces.

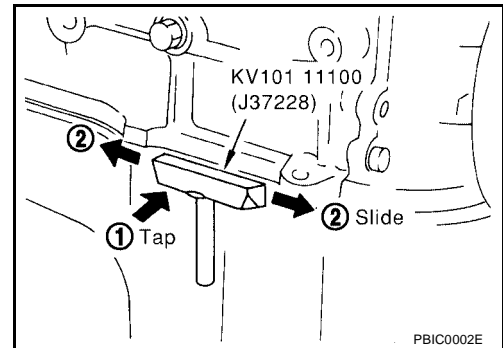

LIQUID GASKET APPLICATION PROCEDURE

- Using a scraper, remove the old Silicone RTV Sealant adhering to the gasket application surface and the mating surface.
- Remove the sealant completely from the groove of the gasket application surface, mounting bolts, and bolt holes.
- Thoroughly clean the gasket application surface and the mating surface and remove adhering moisture, grease and foreign materials.

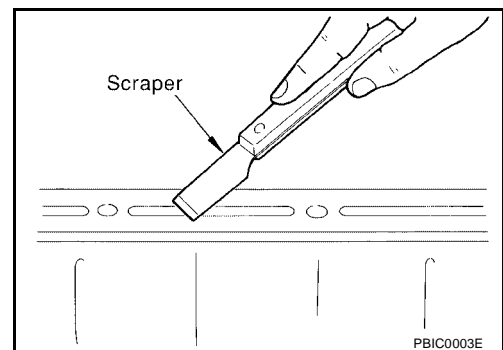

- Attach the sealant tube to the tube presser.
Use Genuine Silicone RTV Sealant or equivalent. Refer to [GI-44, "RECOMMENDED CHEMICAL PRODUCTS AND SEALANTS"](#).

- Apply the sealant using Tool without breaks to the specified location with the specified dimensions.

Tube presser

WS39930000 (-)

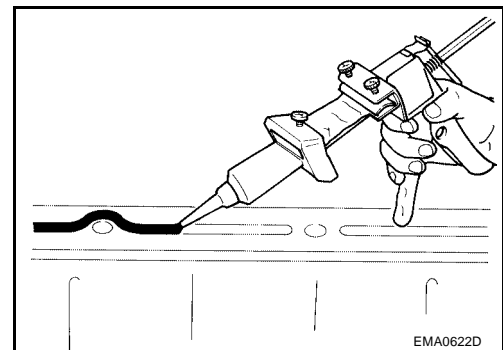

- If there is a groove for the sealant application, apply the sealant to the groove.
- As for the bolt holes, normally apply the sealant inside the holes. If specified, it should be applied outside the holes. Make sure to read the text of this manual.
- Within five minutes of the sealant application, install the mating component.
- If the sealant protrudes, wipe it off immediately.
- Do not retighten after the installation.
- After 30 minutes or more have passed from the installation, fill the engine with the specified oil and coolant. Refer to [MA-13, "RECOMMENDED FLUIDS AND LUBRICANTS"](#).

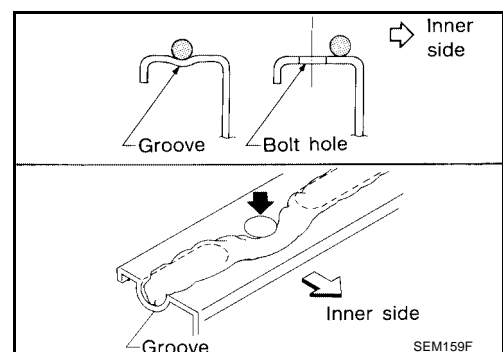

CAUTION:

Follow all specific instructions in this manual.

PREPARATION

[QR25DE]

PFP:00002

EBS00CFJ

PREPARATION

Special Service Tools

The actual shapes of the Kent-Moore tools may differ from those of the special service tools illustrated here.

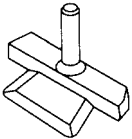
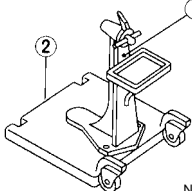
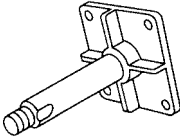
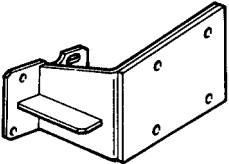
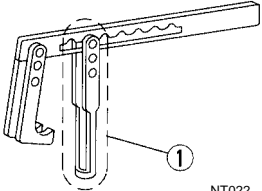
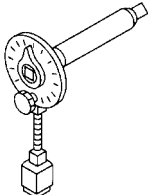
Tool number (Kent-Moore No.) Tool name	Description
KV10111100 (J-37228) Seal cutter	Removing oil pan and timing chain case  <p style="text-align: center;">S-NT046</p>
ST0501S000 Engine stand assembly 1. ST05011000 (—) Engine stand 2. ST05012000 (—) Base	Disassembling and assembling  <p style="text-align: center;">NT042</p>
KV10106500 (—) Engine stand shaft	Disassembling and assembling  <p style="text-align: center;">NT028</p>
KV10115300 (—) Engine sub-attachment	Disassembling and assembling  <p style="text-align: center;">ZZA1078D</p>
KV10116200 (J-26336-B) Valve spring compressor 1. KV10115900 (J-26336-20) Attachment 2. KV10109220 (—) Adapter	Disassembling valve mechanism  <p style="text-align: center;">NT022</p>
KV10112100 (BT-8653-A) Angle wrench	Tightening bolts for bearing cap, cylinder head, etc. in angle.  <p style="text-align: center;">S-NT014</p>

A

EM

C

D

E

F

G

H

I

J

K

L

M

PREPARATION

[QR25DE]

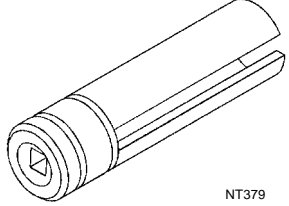
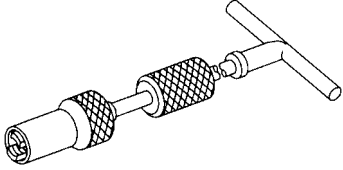
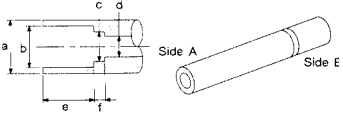
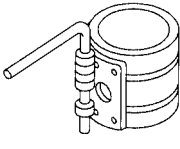
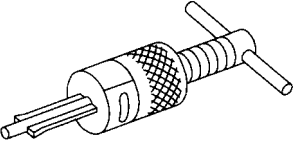
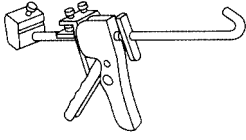
Tool number (Kent-Moore No.) Tool name	Description
KV10117100 (J-36471-A) Heated oxygen sensor wrench  NT379	Loosening or tightening heated oxygen sensors with 22 mm (80.87 in) hexagon nut
KV10107902 (J-38959) Valve oil seal puller  S-NT011	Removing valve oil seal
KV10115600 (J-38958) Valve oil seal drift  S-NT603	Installing valve oil seal Use side A. a: 20 (0.79) dia. d: 8 (0.31) dia. b: 13 (0.51) dia. e: 10.7 (0.421) dia. c: 10.3 (0.406) dia. f: 5 (0.20) dia. Unit: mm (in)
EM03470000 (J-8037) Piston ring compressor  S-NT044	Installing piston assembly into cylinder bore
ST16610001 (J-23907) Pilot bushing puller  S-NT045	Removing crankshaft pilot bushing
WS39930000 (—) Tube presser  S-NT052	Pressing the tube of liquid gasket

PREPARATION

[QR25DE]

Tool number (Kent-Moore No.) Tool name	Description	A
— (J-45488) Quick connector release	Removing fuel tube quick connectors in engine room	EM
— (J-46535) Drive belt tension releaser	Releasing drive belt tension	C
		D
		E
		F
		G
		H
		I
		J
		K
		L
		M

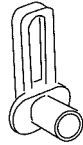

PBIC0198E

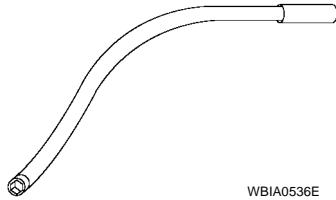

WBIA0536E

PREPARATION

[QR25DE]

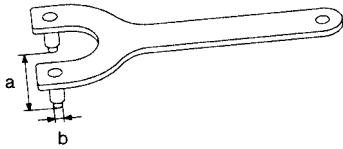
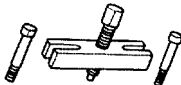
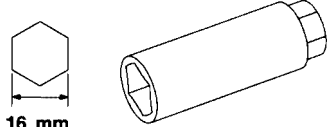
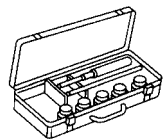
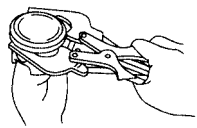
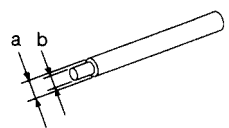
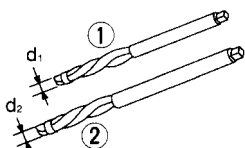

EBS00CFK

Commercial Service Tools

(Kent-Moore No.) Tool name	Description
Pulley holder  NT628	Crankshaft pulley removing and installing a: 68 mm (2.68 in) dia. b: 8mm (0.31 in) dia.
Crank puller  ZZA0010D	Crankshaft pulley removing
Spark plug wrench  16 mm (0.63 in) S-NT047	Removing and installing spark plug
Valve seat cutter set  S-NT048	Finishing valve seat dimensions
Piston ring expander  S-NT030	Removing and installing piston ring
Valve guide drift  S-NT015	Removing and installing valve guide Intake & Exhaust: a: 9.5 mm (0.374 in) dia. b: 5.5 mm (0.217 in) dia.
Valve guide reamer  S-NT016	1: Reaming valve guide inner hole 2: Reaming hole for oversize valve guide Intake & Exhaust: d1 : 6.0 mm (0.236 in) dia. d2 : 10.2 mm (0.402 in) dia.

PREPARATION

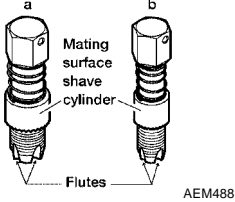
[QR25DE]

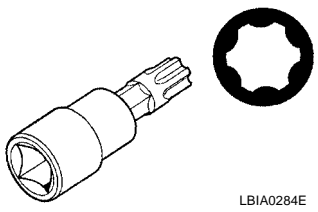
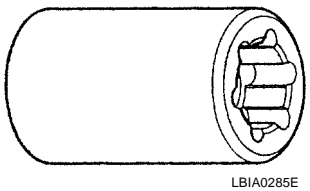
(Kent-Moore No.) Tool name	Description	
Oxygen sensor thread cleaner a: (J-43897-18) b: (J-43897-12)	 <p>Reconditioning the exhaust system threads before installing a new oxygen sensor (Use with anti-seize lubricant shown below.) a: (18 mm 0.71in) for zirconia oxygen sensor b: (12 mm 0.47 in) for titania oxygen sensor</p>	A EM C
Anti-seize lubricant (Permatex 133AR or equivalent meeting MIL specification MIL-A-907)	 <p>Lubricating oxygen sensor thread cleaning tool when reconditioning exhaust system threads</p>	D E
TP50 Torx plus Bit (J-45737)	 <p>Removing and installing M/T flywheel bolts (QR25DE M/T)</p>	F G
E20 Torx Socket (J-45816)	 <p>Removing and installing A/T drive plate bolts (QR25DE A/T)</p>	H I J

NVH Troubleshooting —Engine Noise

EBS00CFL

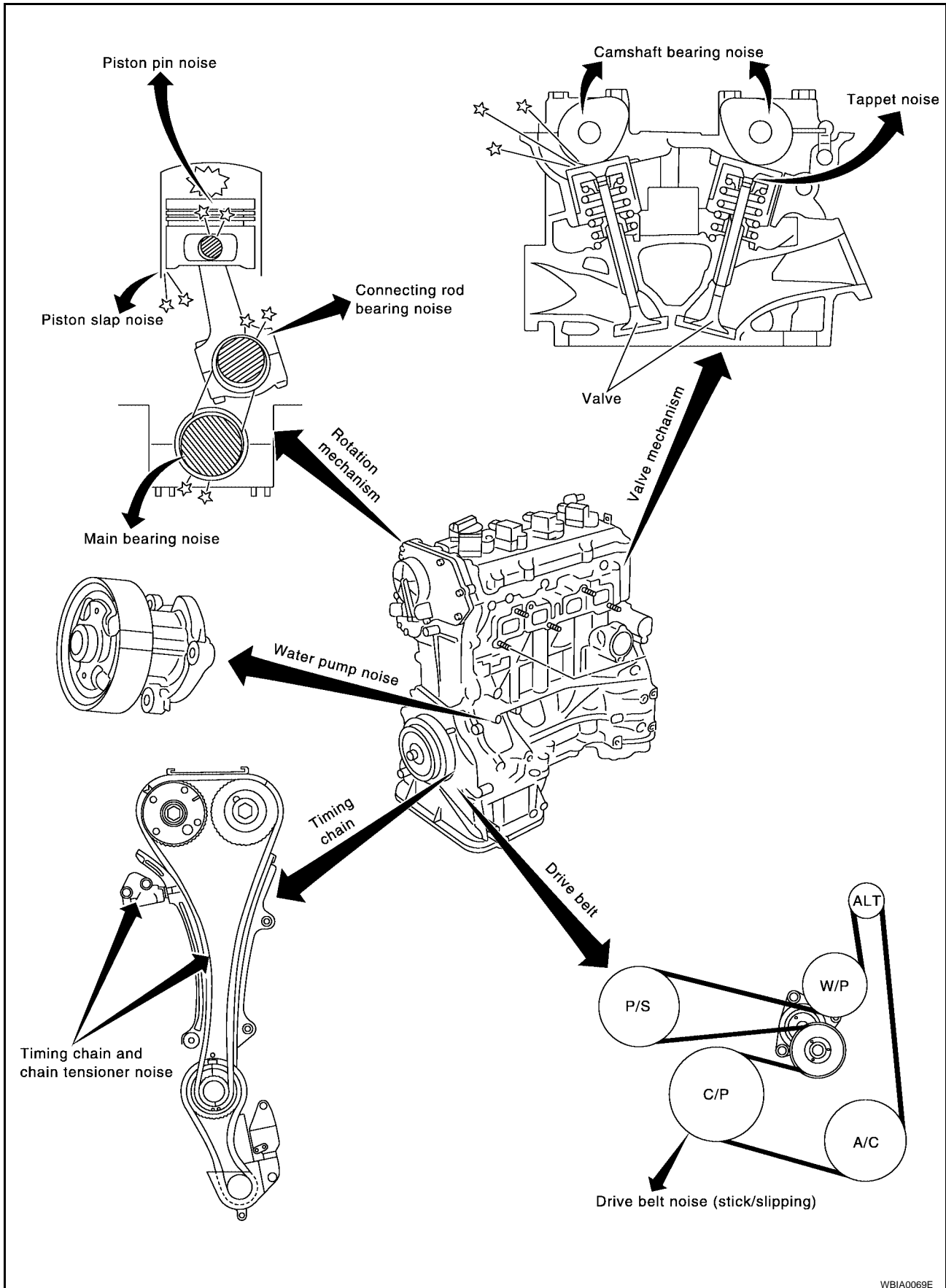

WBIA0069E

NOISE, VIBRATION, AND HARSHNESS (NVH) TROUBLESHOOTING

[QR25DE]

EBS00CFM

Use the Chart Below to Help You Find the Cause of the Symptom.

1. Locate the area where noise occurs.
2. Confirm the type of noise.
3. Specify the operating condition of engine.
4. Check specified noise source.

If necessary, repair or replace these parts.

Location of noise	Type of noise	Operating condition of engine						Source of noise	Check item	Reference page
		Before warm-up	After warm-up	When starting	When idling	When racing	While driving			
Top of engine Rocker cover Cylinder head	Ticking or clicking	C	A	—	A	B	—	Tappet noise	Valve clearance	EM-130
	Rattle	C	A	—	A	B	C	Camshaft bearing noise	Camshaft journal clearance Camshaft runout	EM-126 EM-125
Crankshaft pulley Cylinder block (Side of engine) Oil pan	Slap or knock	—	A	—	B	B	—	Piston pin noise	Piston and piston pin clearance Connecting rod bushing clearance	EM-178 EM-178
	Slap or rap	A	—	—	B	B	A	Piston slap noise	Piston-to-bore clearance Piston ring side clearance Piston ring end gap Connecting rod bend and torsion	EM-177 EM-177 EM-177 EM-177
	Knock	A	B	C	B	B	B	Connecting rod bearing noise	Connecting rod bushing clearance (Small end) Connecting rod bearing clearance (Big end)	EM-178 EM-178
	Knock	A	B	—	A	B	C	Main bearing noise	Main bearing oil clearance Crankshaft runout	EM-183 EM-182
Front of engine Timing chain cover	Tapping or ticking	A	A	—	B	B	B	Timing chain and chain tensioner noise	Timing chain cracks and wear Timing chain tensioner operation	EM-134
Front of engine	Squeaking or fizzing	A	B	—	B	—	B	Drive belts (Sticking or slipping)	Drive belts deflection	EM-100
	Creaking	A	B	A	B	A	B	Drive belts (Slipping)	Idler pulley bearing operation	
	Squall Creak	A	B	—	B	A	B	Water pump noise	Water pump operation	CO-23

A: Closely related B: Related C: Sometimes related —: Not related

DRIVE BELTS

PF0:02117

Checking Drive Belts

EBS00KBL

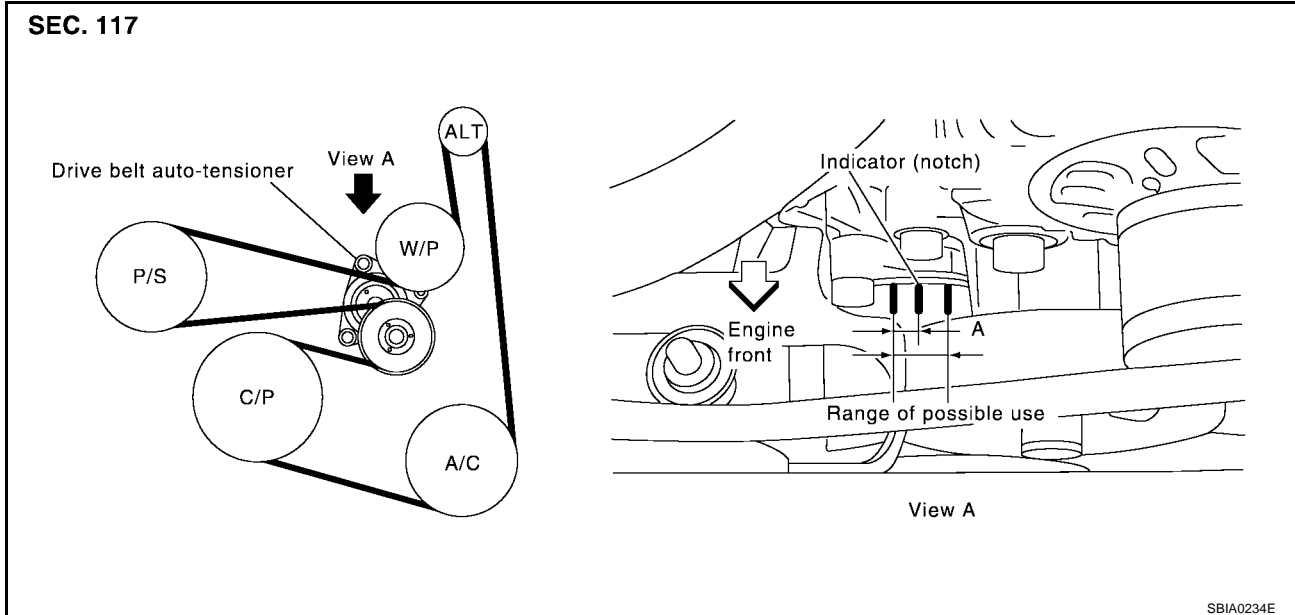

NOTE:

On vehicles not equipped with A/C, there is an idler pulley in the position for the drive belt routing.

WARNING:

Inspect the drive belt only when the engine is stopped.

- Make sure that the stamp mark of drive belt auto-tensioner is within the usable range.

NOTE:

- Check the drive belt auto-tensioner indication when the engine is cold.
- When the new drive belt is installed, the range should be A.
- Visually check entire belt for wear, damage or cracks.
- If the indicator is out of allowable use range or belt is damaged, replace the belt.

Tension Adjustment

EBS00KBM

Belt tension is not manually adjustable, it is automatically adjusted by the drive belt auto-tensioner.

Removal and Installation

EBS00KBN

REMOVAL

1. Remove front RH engine side cover.
2. While securely holding the hexagonal part in pulley center of drive belt auto-tensioner, move in the direction of arrow (loosening direction of tensioner) using Tool.

Tool number : — (J-46535)

CAUTION:

- Avoid placing hand in a location where pinching may occur if the holding tool accidentally comes off.
- Do not loosen the auto-tensioner pulley bolt. (Do not turn it counterclockwise.) If turned counterclockwise, the complete auto-tensioner must be replaced as a unit, including pulley.

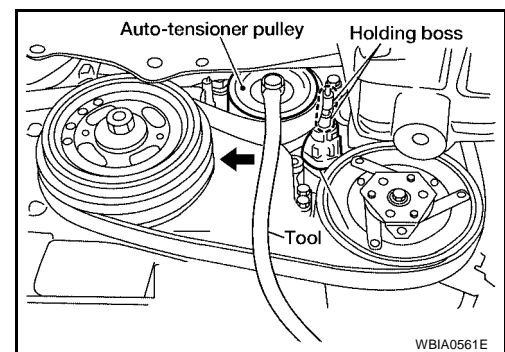

3. Insert a rod approximately 6 mm (0.24 in) in diameter through the rear of tensioner into retaining boss to lock tensioner pulley.

NOTE:

Leave tensioner pulley arm locked until belt is installed again.

4. Loosen auxiliary drive belt from water pump pulley in sequence, and remove it.

INSTALLATION

Installation is in the reverse order of removal.

CAUTION:

- Do not loosen the auto-tensioner pulley bolt. (Do not turn it counterclockwise.) If turned counterclockwise, the complete auto-tensioner must be replaced as a unit, including pulley.
- Avoid placing hand in a location where pinching may occur if the holding tool accidentally comes off.
- Confirm belts are completely set on the pulleys.

NOTE:

- Turn crankshaft pulley clockwise several times to equalize tension between each pulley.
- Confirm tension of drive belt at indicator (notch on fixed side) is within the possible use range. Refer to [EM-100](#).

Removal and Installation of Drive Belt Auto-tensioner

EBS00KBO

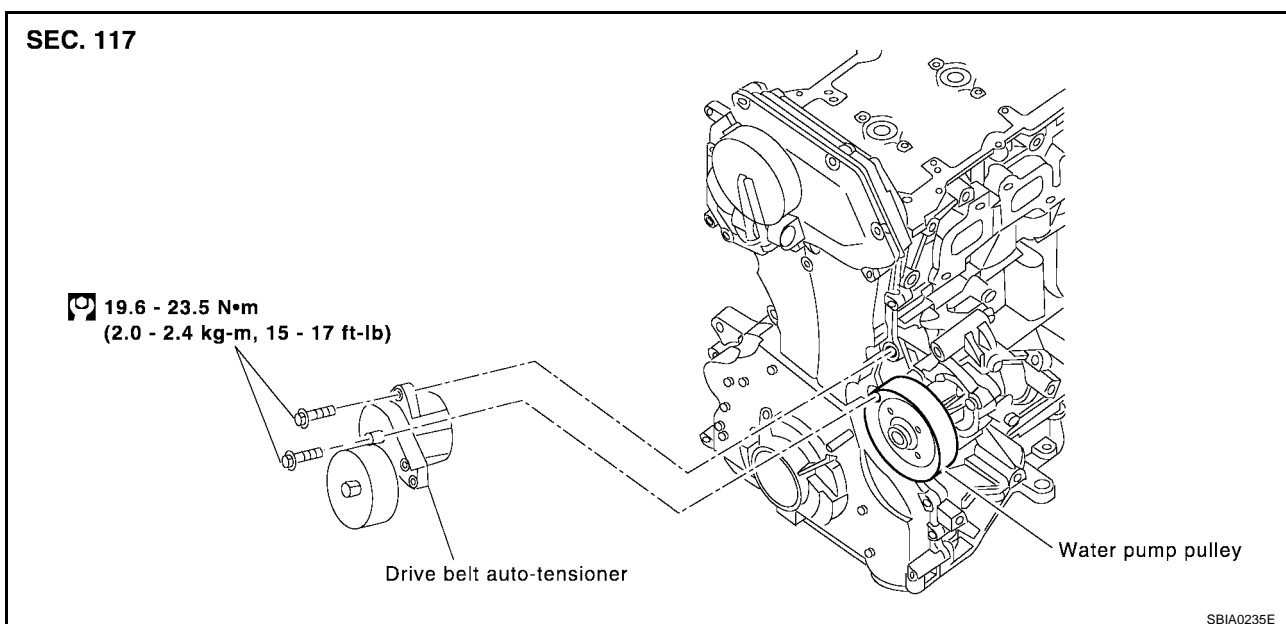
**CAUTION:**

The complete auto-tensioner must be replaced as a unit, including the pulley.

REMOVAL

1. Remove the front RH engine side cover.
2. Remove the drive belt. Refer to [EM-100, "REMOVAL"](#).
3. Remove the alternator. Refer to [SC-32, "Removal"](#).
4. Remove the drive belt auto-tensioner, using power tool.

CAUTION:

Do not loosen the auto-tensioner pulley bolt. (Do not turn it counterclockwise.) If turned counterclockwise, the complete auto-tensioner must be replaced as a unit, including pulley.

INSTALLATION

1. Install drive belt auto-tensioner.
2. While securely holding the hexagonal part in pulley center of drive belt auto-tensioner, move in the direction of arrow (loosening direction of tensioner) using Tool.

Tool number : — (J-46535)

CAUTION:

- Avoid placing hand in a location where pinching may occur if the holding tool accidentally comes off.

DRIVE BELTS

[QR25DE]

-
- **Do not loosen the auto-tensioner pulley bolt. (Do not turn it counterclockwise.) If turned counterclockwise, the complete auto-tensioner must be replaced as a unit, including pulley.**
 - 3. Insert a rod approximately 6 mm (0.24 in) in diameter through the rear of tensioner into retaining boss to lock tensioner pulley.

NOTE:

Leave tensioner pulley arm locked until belt is installed.

CAUTION:

- **Install the drive belt auto-tensioner carefully so not to damage the water pump pulley.**
- **If there is damage greater than peeled paint, replace the drive belt auto-tensioner.**
- **Do not swap the pulley between the new and old auto-tensioner unit.**
- 4. Installation of the remaining components is in the reverse order of removal.

AIR CLEANER AND AIR DUCT

Removal and Installation

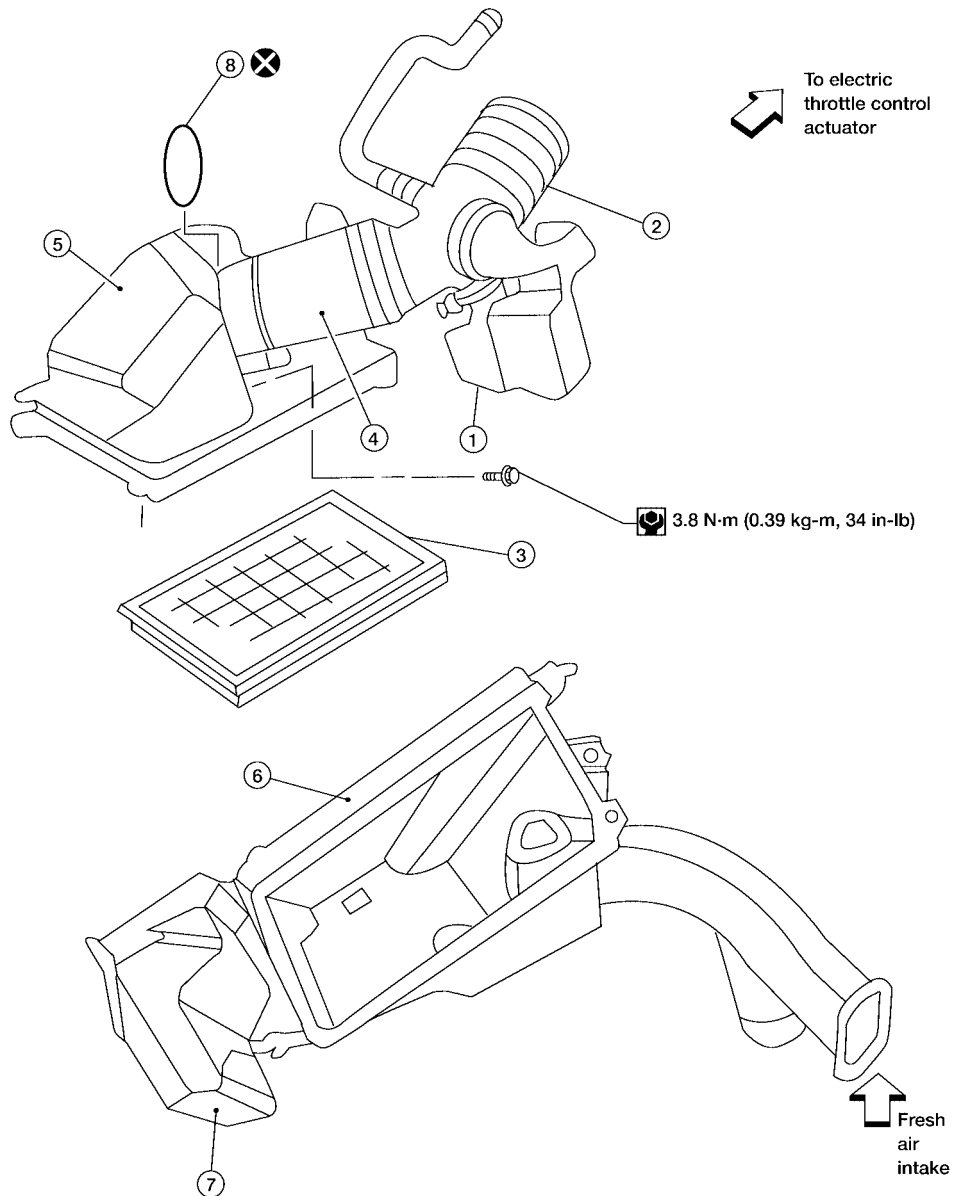

: Always replace after every disassembly.

- | | | |
|-------------------------|---|-----------------------------|
| 1. Resonator | 2. Air cleaner to electric throttle control actuator tube | 3. Air cleaner element |
| 4. Mass air flow sensor | 5. Air cleaner case (upper) | 6. Air cleaner case (lower) |
| 7. Resonator | 8. O-ring | |

REMOVAL

1. Disconnect the mass air flow sensor electrical connector.
2. Disconnect the tube clamp at the electric throttle control actuator.
3. Remove air cleaner to electric throttle control actuator tube and air cleaner case (upper) with the mass air flow sensor attached.
4. Remove mass air flow sensor from air cleaner case (upper), as necessary.

A
EM
C
D
E
F
G
H
I
J
K
L
M

CAUTION:

Handle the mass air flow sensor with care:

- Do not shock it.
- Do not disassemble it.
- Do not touch the internal sensor.

5. Remove the air cleaner element, as necessary and replace it with a new element.
6. Remove the air cleaner case (lower).

INSTALLATION

Installation is in the reverse order of removal.

- Attach each joint according to the alignment marks made during removal. Screw all clamps firmly.

CHANGING THE AIR CLEANER ELEMENT

1. Unhook the air cleaner case side clips and raise the air cleaner case (upper).
2. Remove the air cleaner element.
3. Replace the air cleaner element with a new element and install the air cleaner case (upper).

INTAKE MANIFOLD

Removal and Installation

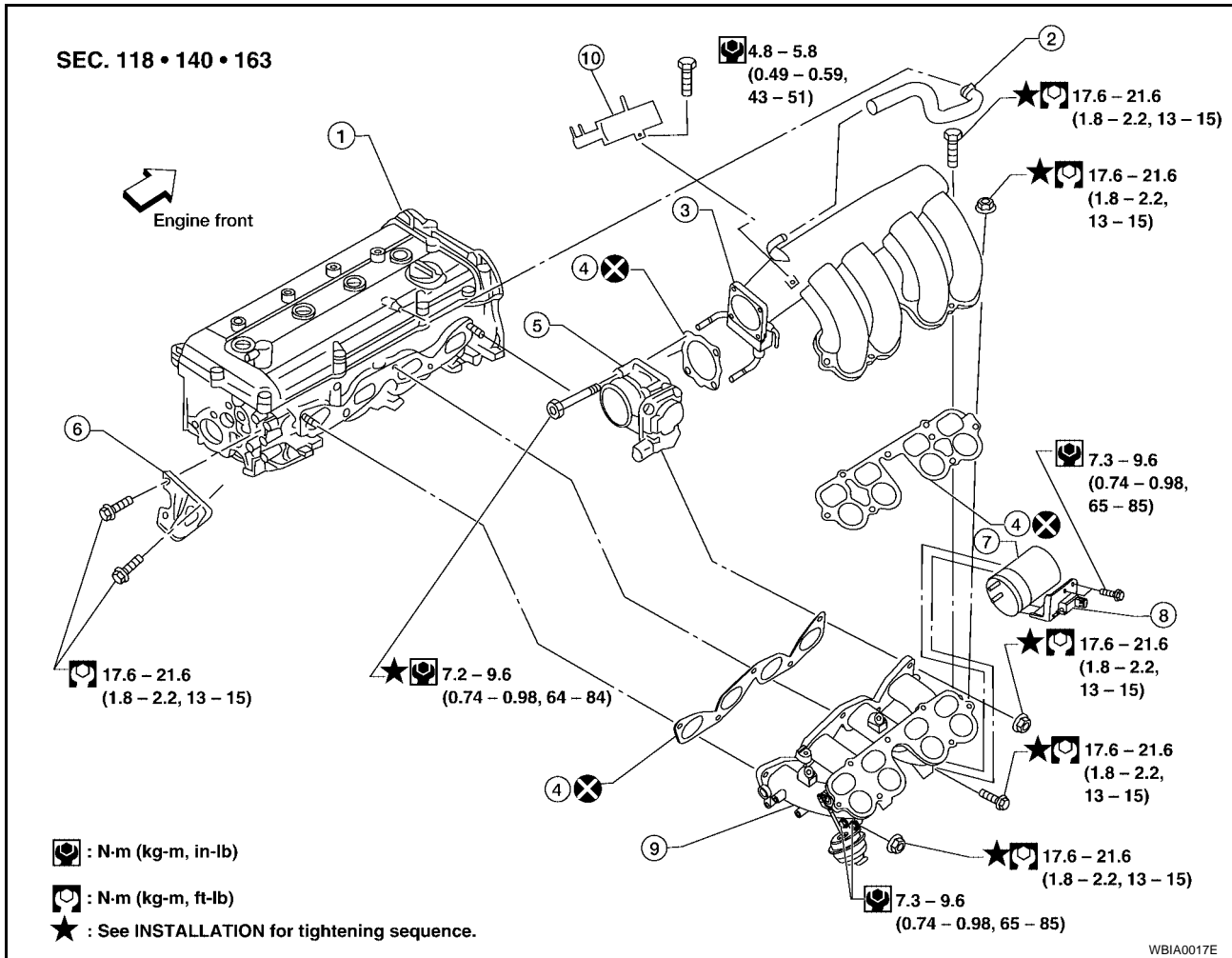

- | | | |
|---|---------------------------------------|------------------------------|
| 1. Cylinder head assembly | 2. PCV hose | 3. Intake manifold collector |
| 4. Gasket | 5. Electric throttle control actuator | 6. Intake manifold support |
| 7. Vacuum reservoir tank | 8. VIAS control solenoid valve | 9. Intake manifold |
| 10. EVAP canister purge volume control solenoid | | |

REMOVAL

WARNING:

To avoid the danger of being scalded, never drain the coolant when the engine is hot.

1. Disconnect the negative battery terminal.
2. Release the fuel pressure.
Refer to [EC-1257, "FUEL PRESSURE RELEASE"](#) .
3. Drain coolant when engine is cooled. Refer to [MA-23, "DRAINING ENGINE COOLANT"](#) .
4. Disconnect the MAF sensor electrical connector.
5. Remove air cleaner case and air duct assembly.
Refer to [EM-103, "Removal and Installation"](#) .
6. Disconnect the following components at the intake side:
 - a. PCV hose
 - b. EVAP canister purge volume control solenoid
 - c. Electric throttle control actuator
 - d. Brake booster vacuum hose

INTAKE MANIFOLD

[QR25DE]

7. Disconnect the fuel quick connector on the engine side.

- Using Tool perform the following steps to disconnect the quick connector.

Tool number : — (J-45488)

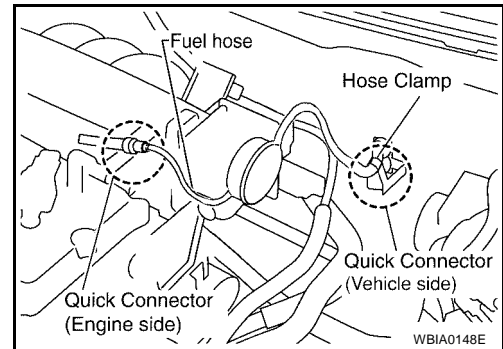

a. Remove quick connector cap.

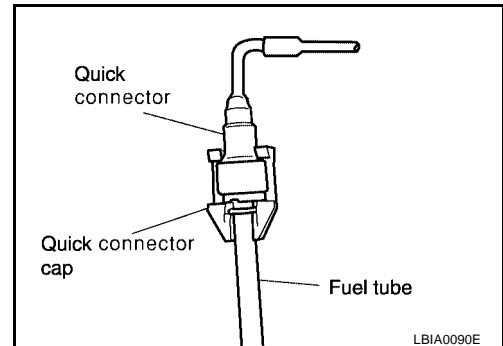

b. With the sleeve side of Tool facing quick connector, install Tool onto fuel tube.

c. Insert Tool into quick connector until sleeve contacts and goes no further. Hold the Tool on that position.

CAUTION:

Inserting the Tool hard will not disconnect quick connector. Hold Tool where it contacts and goes no further.

d. Pull the quick connector straight out from the fuel tube.

CAUTION:

- Pull quick connector holding it at the "A" position, as shown.

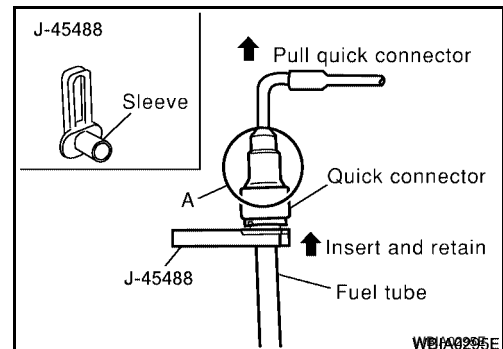

- Do not pull with lateral force applied. O-ring inside quick connector may be damaged.

- Prepare container and cloth beforehand as fuel will leak out.

- Avoid fire and sparks.

- Be sure to cover openings of disconnected pipes with plug or plastic bag to avoid fuel leakage and entry of foreign materials.

8. When removing fuel hose quick connector at vehicle piping side, perform as follows.

a. Remove quick connector cap.

b. Hold the sides of the connector, push in tabs and pull out the tube. (The figure is shown for reference only.)

- If the connector and the tube are stuck together, push and pull several times until they start to move. Then disconnect them by pulling.

CAUTION:

- The tube can be removed when the tabs are completely depressed. Do not twist it more than necessary.

- Do not use any tools to remove the quick connector.

- Keep the resin tube away from heat. Be especially careful when welding near the tube.

- Prevent acid liquid such as battery electrolyte etc. from getting on the resin tube.

- Do not bend or twist the tube during installation and removal.

- Do not remove the remaining retainer on tube.

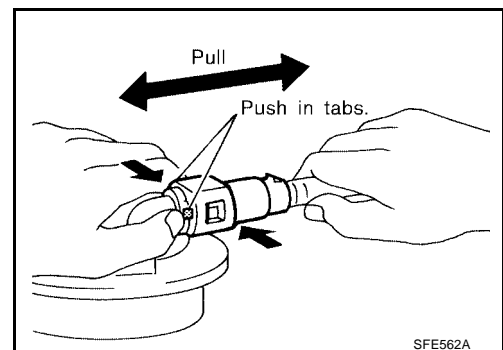

INTAKE MANIFOLD

[QR25DE]

- When the tube is replaced, also replace the retainer with a new one.
Retainer color: Green.
 - To keep clean the connecting portion and to avoid damage and foreign materials, cover them completely with plastic bags or something similar.
9. Loosen mounting bolts diagonally, and remove the electric throttle control actuator.
- CAUTION:**
Handle carefully to avoid any damage.
10. Disconnect intake manifold collector harness, and vacuum hose.
- CAUTION:**
Cover engine openings to avoid entry of foreign materials.
11. Remove intake manifold collector mounting bolts on the support.
12. Loosen the mounting bolts and nuts in the order shown to remove the intake manifold collector.

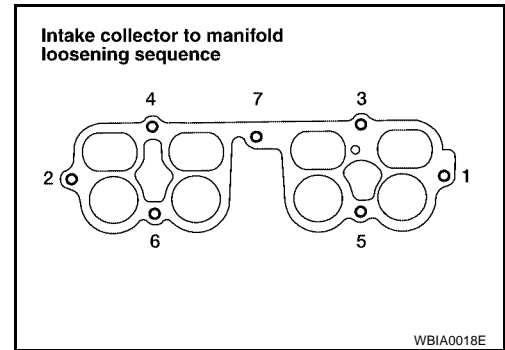

13. Loosen the bolts in the order shown to remove the intake manifold assembly.

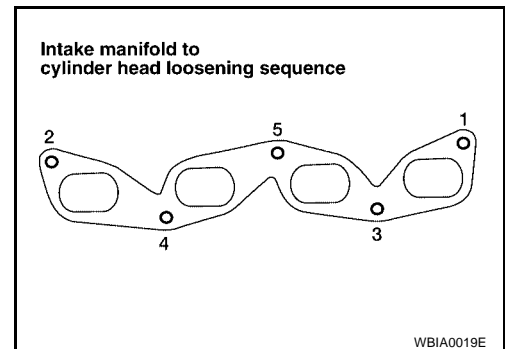

INSPECTION AFTER REMOVAL

Surface Distortion

- Using straightedge and feeler gauge, inspect surface distortion of intake manifold collector and intake manifold surface.

Standard : 0.1 mm (0.004 in)

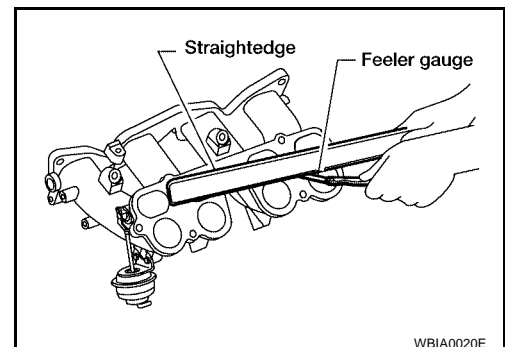

INSTALLATION

Installation is in the reverse order of removal.

Tightening Intake Manifold Bolts and Nuts

- Install the intake manifold bolts and nuts in the numerical order of the tightening sequence as shown.

CAUTION:

After tightening No.5, retighten the No.1 mounting bolt to specification.

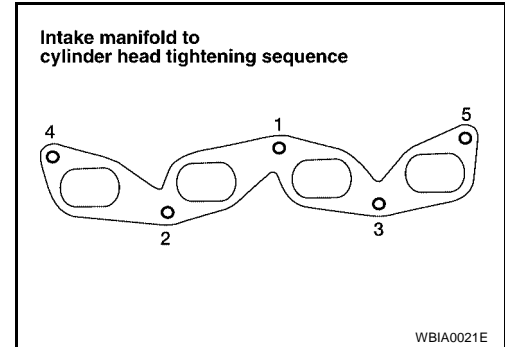

Tightening Intake Manifold Collector Bolts and Nuts

- Tighten in numerical order as shown.

CAUTION:

After tightening No.7, retighten the No.1 mounting bolt to specification.

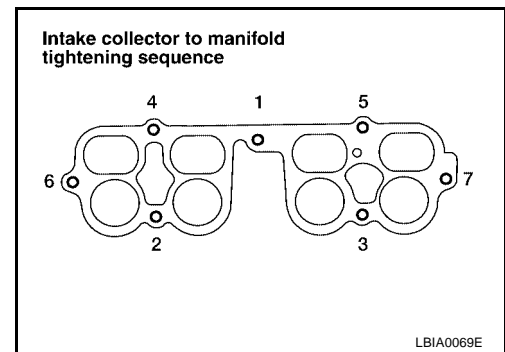

Installation of Electric Throttle Control Actuator:

- Tighten the mounting bolts of electric throttle control actuator equally and diagonally in several steps.

Electric throttle control actuator mounting bolts

: 7.2 - 9.6 N·m (0.74 - 0.98 kg·m, 64 - 84 in·lb)

- After installation perform procedure in [EM-109, "INSPECTION AFTER INSTALLATION"](#).

CONNECTING QUICK CONNECTOR ON THE FUEL HOSE (ENGINE SIDE)

1. Make sure no foreign substances are deposited in and around the fuel tube and quick connector, and there is no damage to them.
2. Thinly apply new engine oil around the fuel tube tip end.
3. Align center to insert quick connector straight into fuel tube.

- Insert fuel tube into quick connector until the top spool on fuel tubes is inserted completely and the second level spool is positioned slightly below the quick connector bottom end.

CAUTION:

- Hold at position "A" as shown, when inserting the fuel tube into the quick connector.
- Carefully align to center to avoid inclined insertion to prevent damage to the O-ring inside the quick connector.
- Insert the fuel tube until you hear a "click" sound and actually feel the engagement.
- To avoid misidentification of engagement with a similar sound, be sure to perform the next step.

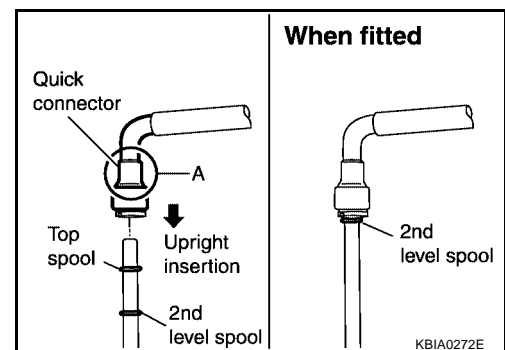

4. Before clamping the fuel hose with the hose clamp, pull the quick connector hard by hand, holding at the "A" position, as shown. Make sure it is completely engaged (connected) so that it does not come off of the fuel tube.

NOTE:

Recommended pulling force is 50 N (5.1 kg, 11.2 lb).

5. Install quick connector cap on quick connector joint.

INTAKE MANIFOLD

[QR25DE]

- Direct arrow mark on quick connector cap to upper side (fuel hose side).
6. Install fuel hose to hose clamp.

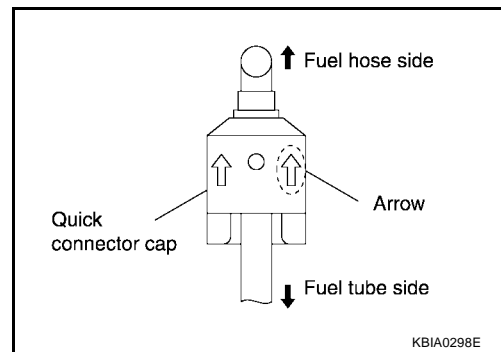

CONNECTING QUICK CONNECTOR ON THE FUEL HOSE (VEHICLE PIPING SIDE)

1. Make sure no foreign substances are deposited in and around the fuel tube and quick connector, and there is no damage to them.
2. Align center to insert quick connector straight into fuel tube.
 - Insert fuel tube until a click is heard.
 - Install quick connector cap on quick connector joint. Direct arrow mark on quick connector cap upper side.
 - Install fuel hose to hose clamp.

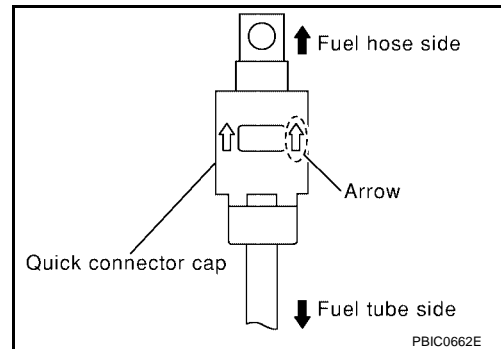

INSPECTION AFTER INSTALLATION

Make sure there is no fuel leakage at connections as follows:

1. Apply fuel pressure to fuel lines by turning ignition switch ON (with engine stopped). Then check for fuel leaks at connections.
2. Start the engine and rev it up and check for fuel leaks at connections.

NOTE:

Use mirrors for checking on connections out of the direct line of sight.

CAUTION:

Do not touch engine immediately after stopping as engine is extremely hot.

- Perform procedures for "Throttle Valve Closed Position Learning" after finishing repairs. Refer to [EC-1255, "Throttle Valve Closed Position Learning"](#) .
- If electric throttle control actuator is replaced, perform procedures for "Idle Air Volume Learning" after finishing repairs. Refer to [EC-1255, "Idle Air Volume Learning"](#) .

EXHAUST MANIFOLD AND THREE WAY CATALYST

[QR25DE]

- Loosen the nuts in the sequence shown, on the exhaust manifold and three way catalyst.
- Remove the exhaust manifold and three way catalyst assembly and gasket. Discard the gasket.

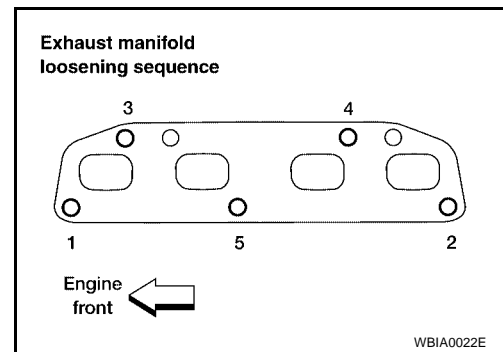

INSPECTION AFTER REMOVAL

Surface Distortion

- Use a reliable straightedge and feeler gauge to check the flatness of exhaust manifold fitting surface.

Standard : 0.3 mm (0.012 in)

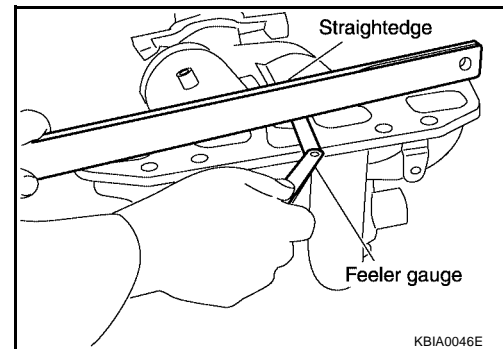

INSTALLATION

Installation is in the reverse order of removal. Pay attention to the following.

Tightening Exhaust Manifold Nuts

- Tighten the nuts in the numerical order shown, to specification. After tightening No.5, retighten No.1 and then No.3 to specification.

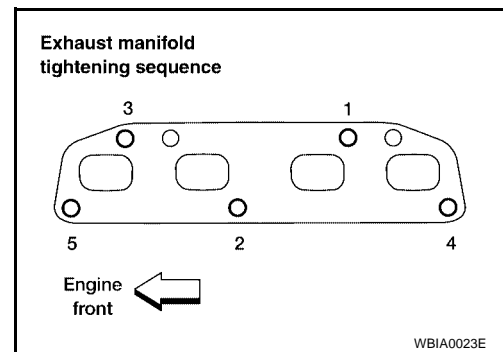

Installation of Heated Oxygen Sensors

Clean the heated oxygen sensor threads with the Tool, then apply the anti-seize lubricant to the threads before installing the heated oxygen sensors.

CAUTION:

Do not over-tighten the heated oxygen sensors. Doing so may cause damage to the heated oxygen sensors, resulting in a malfunction and the MIL coming on.

OIL PAN AND OIL STRAINER

[QR25DE]

7. Remove the lower oil pan bolts. Loosen the bolts in the order shown.

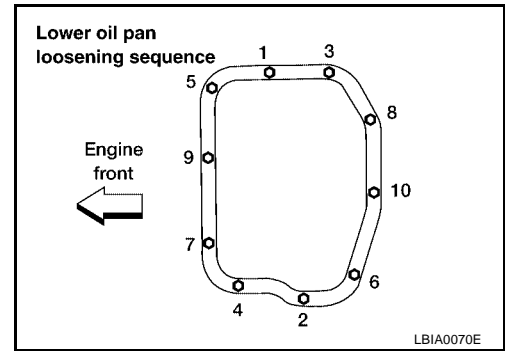

8. Insert the Tool (Seal cutter) between lower oil pan and the upper oil pan to separate them. Tap gently on the side to move the Tool around the pan; do not damage the mating surface.
9. Remove the lower oil pan.
10. Remove the oil pickup screen.
11. Remove rear plate cover, and four engine to transaxle bolts.

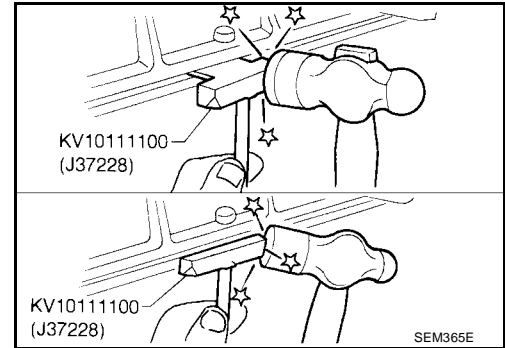

12. Loosen the upper oil pan bolts in the numerical order shown to remove the upper oil pan.

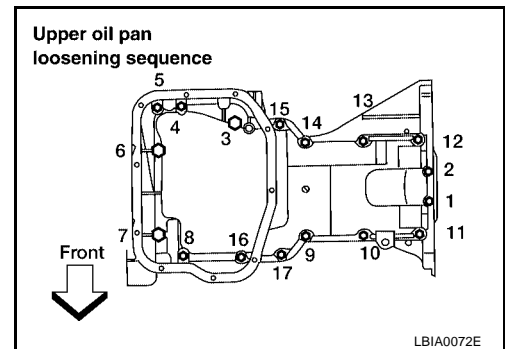

13. Insert the Tool (Seal cutter) between the upper oil pan and the cylinder block to separate them. Tap gently on the side to move the Tool around the pan; do not damage the mating surface.

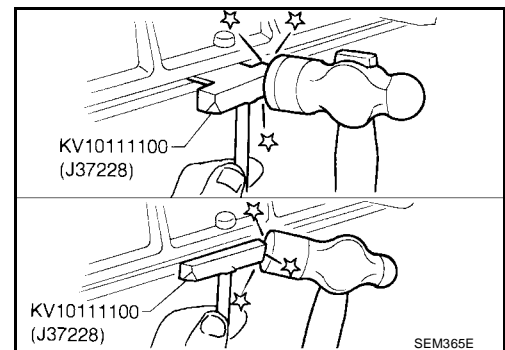

14. Remove the upper oil pan.

INSPECTION AFTER REMOVAL

- Clean the oil pickup screen to remove any foreign material.

INSTALLATION

1. Installation is in the reverse order of removal. Pay attention to the following.

OIL PAN AND OIL STRAINER

[QR25DE]

- a. Apply Genuine Silicone RTV Sealant, or equivalent, to the upper oil pan. Refer to [GI-44, "RECOMMENDED CHEMICAL PRODUCTS AND SEALANTS"](#) , and [EM-92, "Precautions for Liquid Gasket"](#) .
- Install the two new O-rings in the upper oil pan.

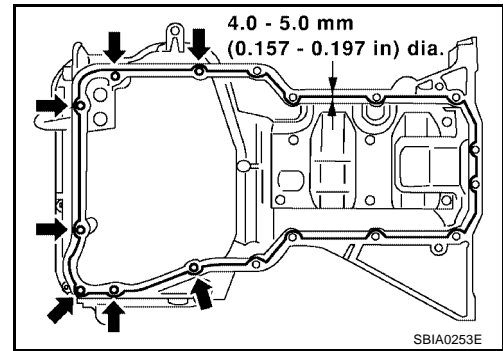

- b. Tighten the upper oil pan bolts in the order as shown.
- Bolt No.10,11,18 indicate a double tightening in the sequence of bolt No.s 1, 2, 3.

NOTE:

Refer below for specified bolt sizes:

M6 × 20 mm (0.79 in): No.19, 20

M8 × 25 mm (0.98 in): No.1, 3, 4, 9

M8 x 45 mm (1.77 in): No.2, 5, 6, 7, 8, 17

M8 x100 mm (3.97 in): No.12, 13, 14, 15, 16

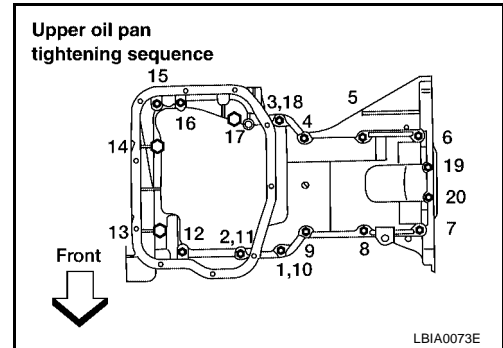

- c. Apply Genuine Silicone RTV Sealant, or equivalent to the lower oil pan. Refer to [GI-44, "RECOMMENDED CHEMICAL PRODUCTS AND SEALANTS"](#) , and [EM-92, "Precautions for Liquid Gasket"](#) .

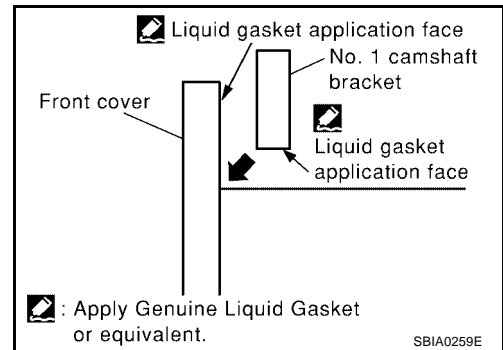

- d. Tighten the lower oil pan bolts in the numerical order shown.
- Wait at least 30 minutes after the oil pans are installed before filling the engine with oil.

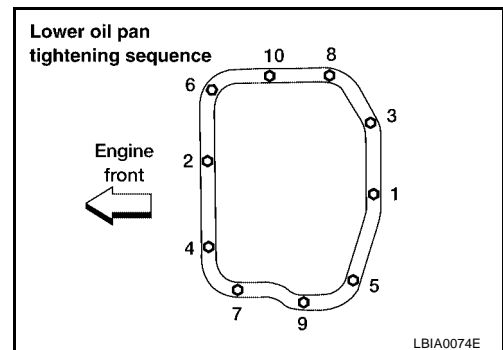

INSPECTION AFTER INSTALLATION

- Check for any engine oil leaks with the engine at full operating temperature and running at idle.

IGNITION COIL

Removal and Installation

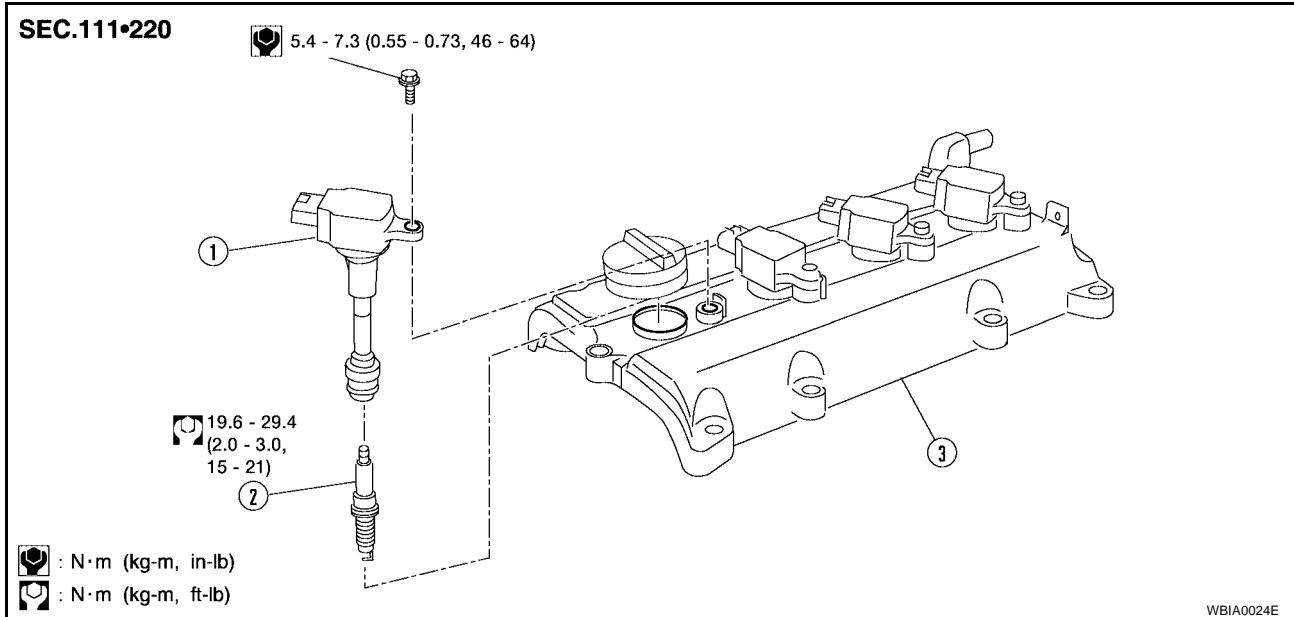

1. Ignition coil

2. Spark plug

3. Rocker cover

REMOVAL

1. Remove the engine cover.
2. Disconnect the harness connector from the ignition coil.
3. Remove the ignition coil.

CAUTION:

Do not drop or shock it.

INSTALLATION

Installation is in the reverse order of removal.

A
EM
C
D
E
F
G
H
I
J
K
L
M

SPARK PLUG

Removal and Installation

EBS00CFW

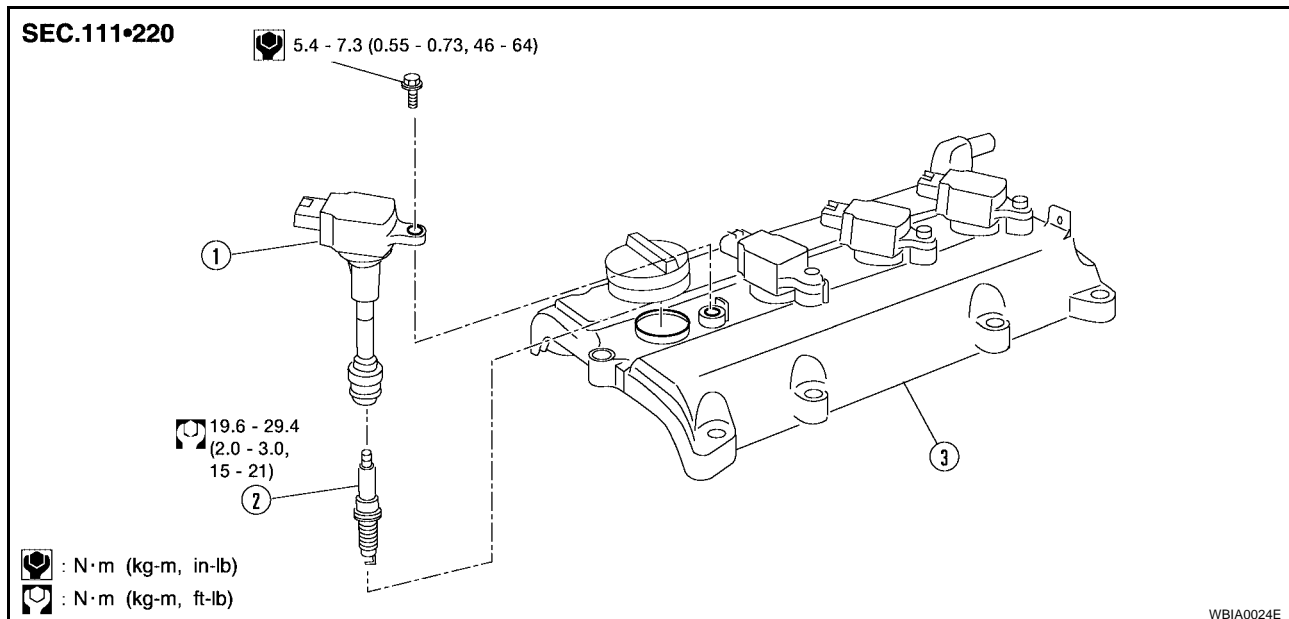

1. Ignition coil

2. Spark plug

3. Rocker cover

REMOVAL

1. Remove the ignition coil. Refer to [EM-115, "Removal and Installation"](#).
2. Remove the spark plug with a suitable spark plug wrench.

Temperature range	NGK
Standard type	PLFR5A-11 (Platinum tipped)
Hot type	PLFR4A-11(Platinum tipped)
Cold type	PLFR6A-11(Platinum tipped)

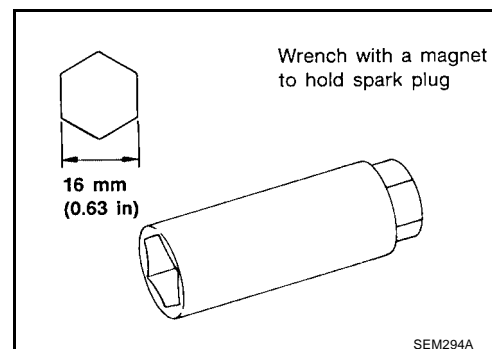

INSPECTION AFTER REMOVAL

- Use standard type spark plug for normal conditions.

The hot type spark plug is suitable when fouling occurs with the standard type spark plug under conditions such as:

- Frequent engine starts.
- Low ambient temperatures.

The cold type spark plug is suitable when spark plug knock occurs with the standard type spark plug under conditions such as:

- Extended highway driving.
- Frequent high engine revolution.

SPARK PLUG

[QR25DE]

Do not use a wire brush for cleaning the spark plugs. Replace as necessary.

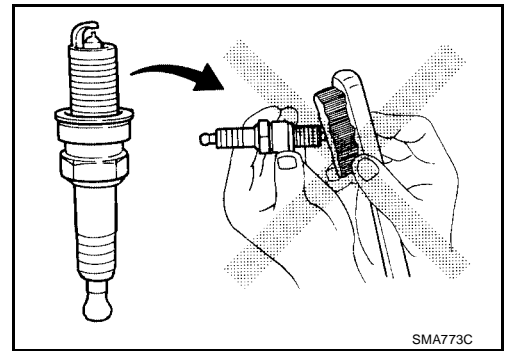

If plug is covered with carbon, a spark cleaner may be used.

Cleaner air pressure : less than 588 kPa (6kg/cm², 85 psi)

Cleaning time : less than 20 seconds

Checking and adjusting plug gap is not required between change intervals.

Gap nominal : 1.1 mm (0.043 in)

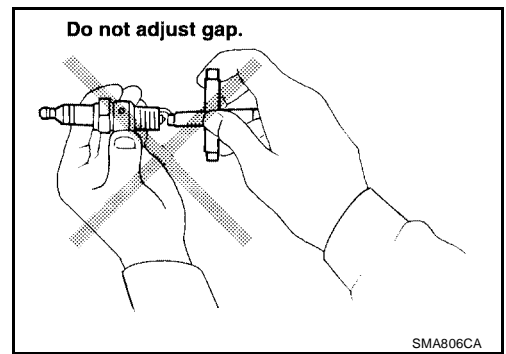

INSTALLATION

- Installation is in the reverse order of removal.

A
EM
C
D
E
F
G
H
I
J
K
L
M

FUEL INJECTOR AND FUEL TUBE

Removal and Installation

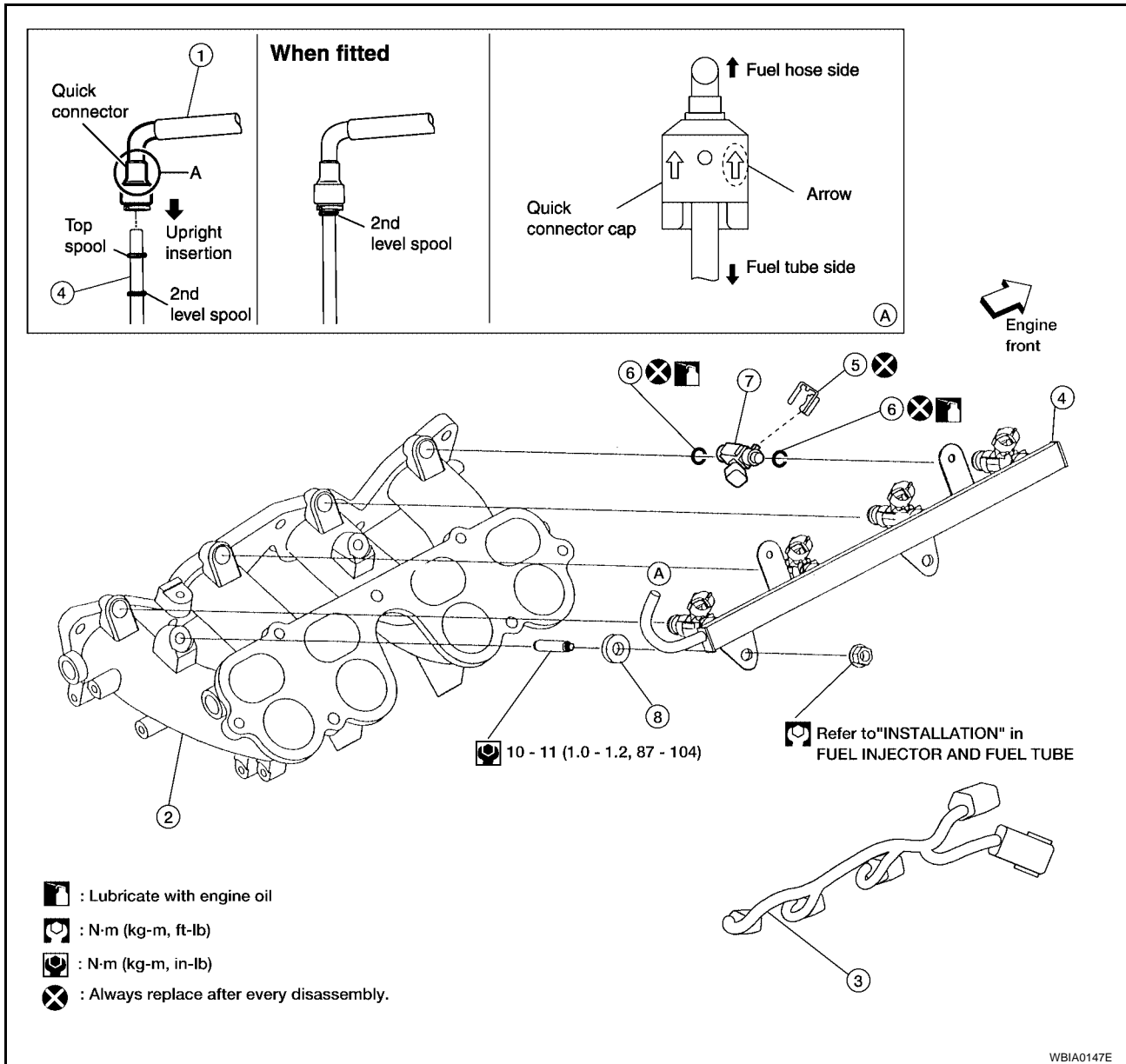

WBIA0147E

- | | | |
|------------------|--------------------|----------------|
| 1. Fuel hose | 2. Intake manifold | 3. Sub-harness |
| 4. Fuel tube | 5. Clip | 6. O-ring |
| 7. Fuel injector | 8. Insulator | |

CAUTION:

- Apply new engine oil to parts before installing the parts, as shown above.
- Do not remove or disassemble parts unless instructed as shown in the figure.

REMOVAL

1. Release the fuel pressure. Refer to [EC-1257, "FUEL PRESSURE RELEASE"](#) .
2. Remove the intake air duct. Refer to [EM-103, "Removal and Installation"](#) .
3. Partially drain the engine coolant. Refer to [MA-23, "DRAINING ENGINE COOLANT"](#) .
4. Remove the intake collector. Refer to [EM-105, "INTAKE MANIFOLD"](#) .
5. Disconnect the fuel hose quick connector at the fuel tube side.
 - For how to disconnect and connect the quick connector, refer to [EM-105, "INTAKE MANIFOLD"](#) .

FUEL INJECTOR AND FUEL TUBE

[QR25DE]

CAUTION:

- Prepare a container and cloth for catching any spilled fuel.
- This operation should be performed in a place that is free from any open flames.
- While hoses are disconnected seal their openings with vinyl bag or similar material to prevent foreign material from entering them.

6. Disconnect sub-harness for injector at engine front side, and remove it from bracket.

7. Loosen the mounting bolts in the order as shown, then remove fuel tube and fuel injectors as an assembly.

8. Remove the fuel injectors from the fuel tube.

- Release the clip and remove the fuel injector.
- Pull fuel injector straight out of the fuel tube.
- Be careful not to damage the nozzle.
- Avoid any impact, such as dropping the fuel injector.
- Do not disassemble or adjust the fuel injector.

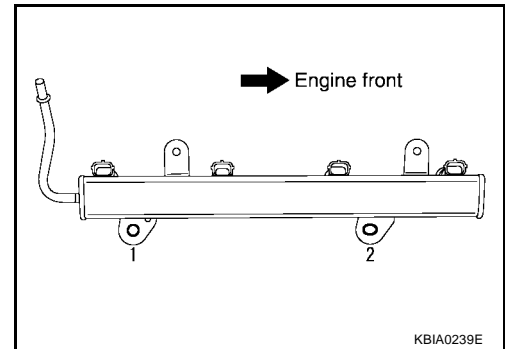

INSTALLATION

1. Install new O-rings on the fuel injector.

- Lubricate the O-rings lightly with new engine oil.
- Be careful not to scratch it during installation. Also be careful not to twist or stretch the O-ring. If the O-ring was stretched while it is attached, do not insert it into the fuel tube immediately.

2. Install the fuel injector into the fuel tube with the following procedure:

- Do not reuse the clip, replace it with a new one.
- Insert the new clip into the clip mounting groove on fuel injector.
- Insert the clip so that the projection on "Lug A" of fuel injector matches notch "A" of the clip.

3. Insert fuel injector into fuel tube with clip attached.

- Insert it while matching it to the axial center.
- Insert fuel injector so that the projection on "Lug B" of fuel injector matches notch "B" of the clip.
- Make sure that fuel tube flange is securely fixed in flange fixing groove on the clip.
- Make sure that installation is complete by checking that fuel injector does not rotate or come off.

4. Install fuel tube assembly.

a. Insert the tip of each fuel injector into intake manifold.

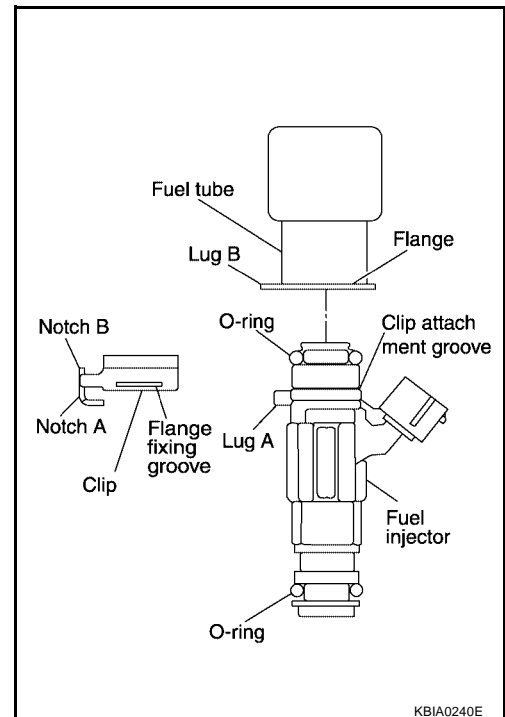

b. Tighten the mounting bolts in two steps in the numerical order shown.

Fuel tube bolt : 9.3 - 10.8 N-m (0.95 - 1.1 kg-m,
tightening 1st step 83 - 95 in-lb)

Fuel tube bolt : 20.6 - 26.5 N-m (2.1 - 2.7 kg-m,
tightening 2nd step 16 - 19 ft-lb)

CAUTION:

- After properly connecting fuel tube assembly to injector and fuel hose, check connection for fuel leakage.

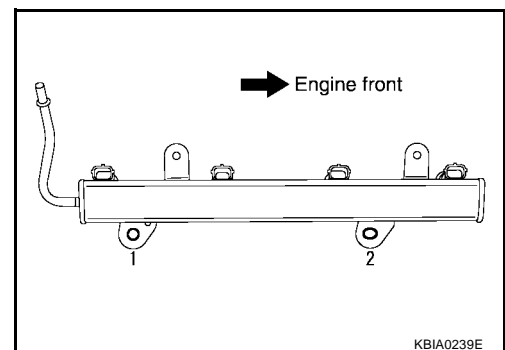

5. Connect the fuel hose quick connector. Refer to [EM-105, "INTAKE MANIFOLD"](#) .
6. Install the intake collector. Refer to [EM-105, "INTAKE MANIFOLD"](#) .
7. Installation of the remaining components is in the reverse order of removal.

INSPECTION AFTER INSTALLATION

Make sure there is no fuel leakage at connections as follows:

1. Apply fuel pressure to fuel lines by turning ignition switch ON (with engine stopped). Then check for fuel leaks at connections.
2. Start the engine and rev it up and check for fuel leaks at connections.

NOTE:

Use mirrors for checking on connections out of the direct line of sight.

CAUTION:

Do not touch engine immediately after stopping as engine is extremely hot.

- Perform procedures for "Throttle Valve Closed Position Learning" after finishing repairs. Refer to [EC-1255, "Throttle Valve Closed Position Learning"](#) .
- If electric throttle control actuator is replaced, perform procedures for "Idle Air Volume Learning" after finishing repairs. Refer to [EC-1255, "Idle Air Volume Learning"](#) .

ROCKER COVER

Removal and Installation

SEC.111-118

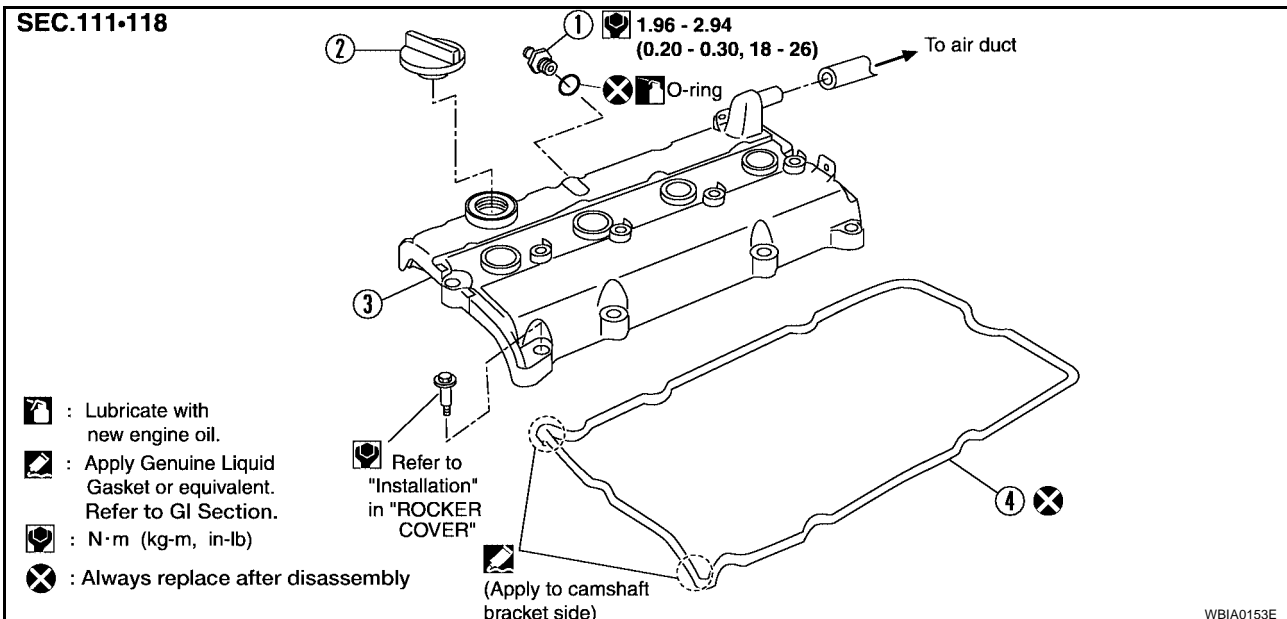

1. PCV valve

2. Oil filler cap

3. Rocker cover

4. Rocker cover gasket

REMOVAL

1. Remove the ignition coils. Refer to [EM-115, "Removal and Installation"](#).
2. Disconnect the PCV hose and breather hose from the rocker cover.
3. Loosen the bolts in the numerical order as shown.
4. Remove the rocker cover. Remove the oil filler cap and PCV valve if necessary, to transfer to the new rocker cover.

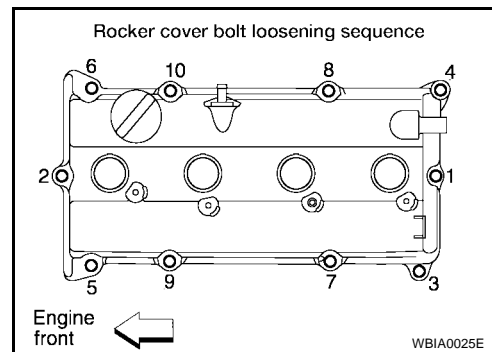

INSTALLATION

1. Apply Silicone RTV Sealant to the joint part of the cylinder head and camshaft bracket following the steps below:
 - a. Refer to illustration "a" to apply sealant to joint part of No.1 camshaft bracket and cylinder head.
 - b. Refer to illustration "b" to apply sealant in a 90° degree angle to the illustration "a".
- **Use Genuine Silicone RTV Sealant, or equivalent. Refer to [GI-44, "RECOMMENDED CHEMICAL PRODUCTS AND SEALANTS"](#).**
2. Install the rocker cover.
 - The rocker cover gasket must be securely installed in the groove in the rocker cover.

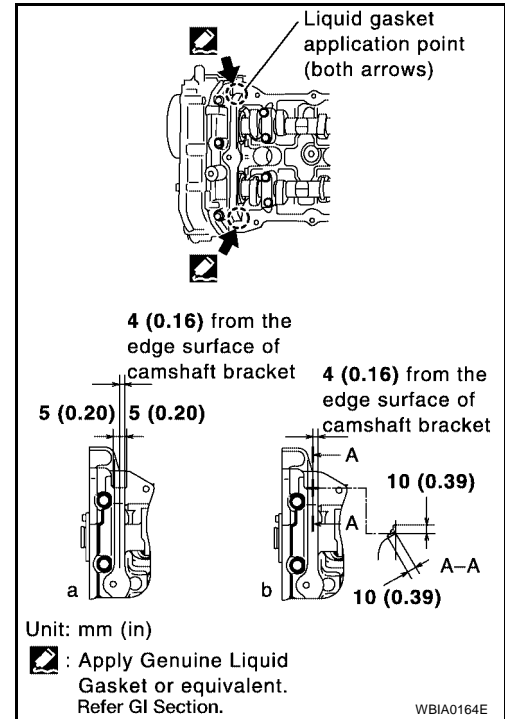

3. Tighten the rocker cover bolts in two steps, in the numerical order as shown.

Rocker cover bolt tightening 1st step : 1.0 - 2.9 N·m (0.1 - 0.3 kg-m, 9 - 26 in-lb)

Rocker cover bolt tightening 2nd step : 7.4 - 9.3 N·m (0.75 - 0.95 kg-m, 65 - 82 in-lb)

4. Connect the PCV hose and breather hose to the rocker cover. If necessary, install the oil filler cap and PCV valve and lubricate the PCV valve O-ring with new engine oil.
5. Install the ignition coils. Refer to [EM-115, "Removal and Installation"](#).

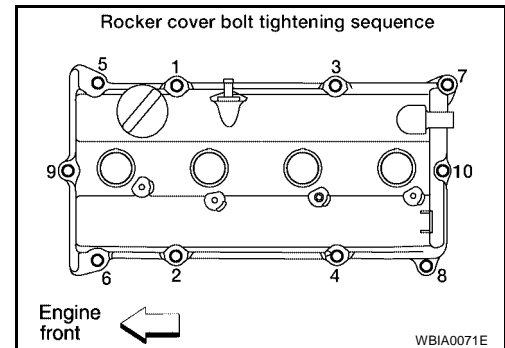

CAMSHAFT

Removal and Installation

SEC.111•130•135

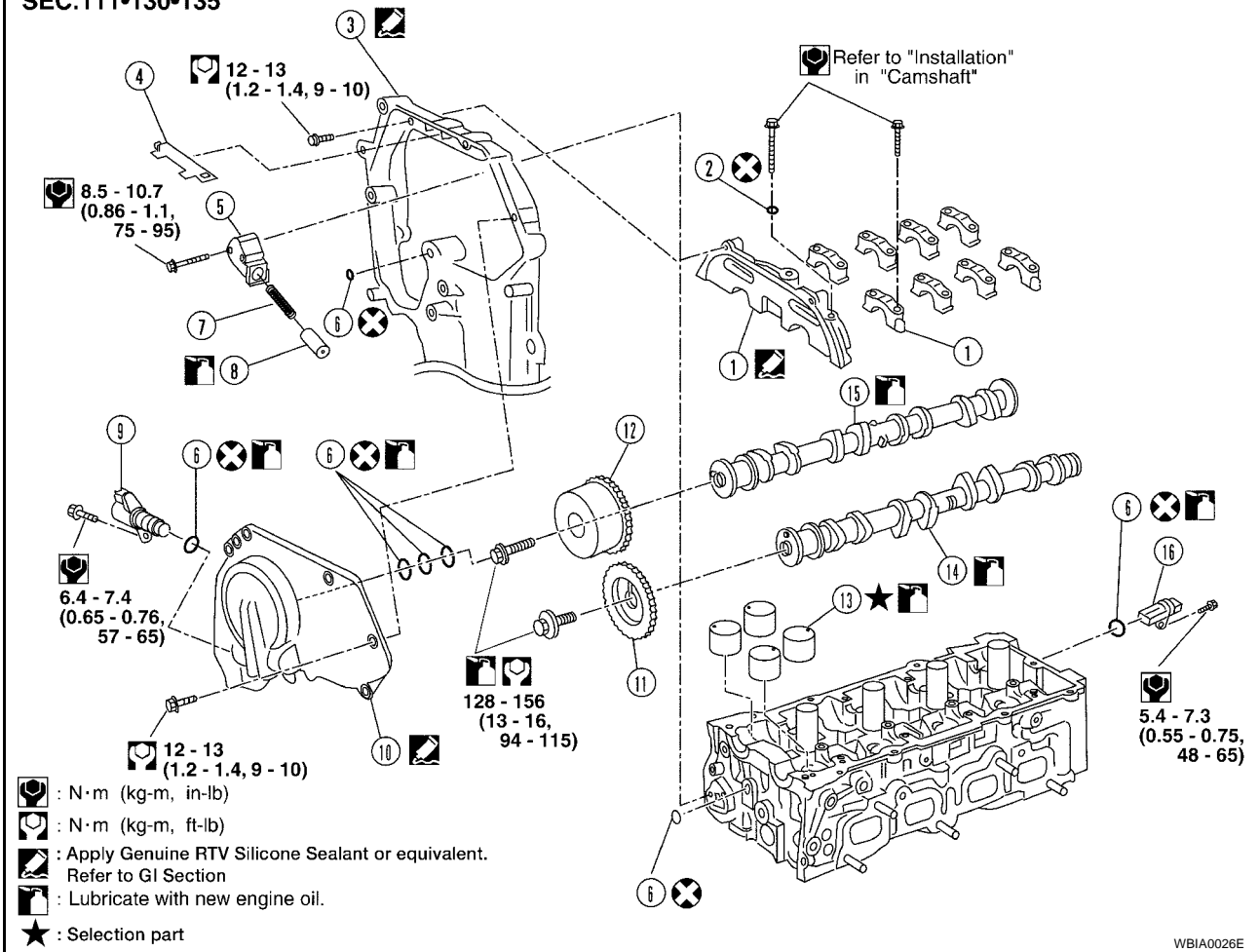

- | | | |
|--------------------------------------|-----------------------------|-------------------------------|
| 1. Camshaft brackets (1 - 5) | 2. Washer | 3. Front cover (partial view) |
| 4. Chain guide | 5. Chain tensioner | 6. O-ring(s) |
| 7. Chain tensioner spring | 8. Chain tensioner plunger | 9. IVT control solenoid valve |
| 10. IVT control cover | 11. Camshaft sprocket (EXH) | 12. Camshaft sprocket (INT) |
| 13. Valve lifter | 14. Camshaft (EXH) | 15. Camshaft (INT) |
| 16. Camshaft position sensor (PHASE) | | |

REMOVAL

1. Remove the rocker cover. Refer to [EM-121, "Removal and Installation"](#).
2. Remove the front right side tire and wheel. Refer to [WT-4, "Removal"](#).
3. Remove the RH splash shield.
4. Remove the drive belt. Refer to [EM-100, "REMOVAL"](#).
5. Remove the coolant overflow reservoir tank.
6. Disconnect the camshaft electrical connector.
7. Disconnect the ground electrical connections from the front cover.

CAMSHAFT

[QR25DE]

8. Remove the IVT control (intake valve timing control) cover by cutting the sealant using Tool.
- Loosen the bolts in the order shown.

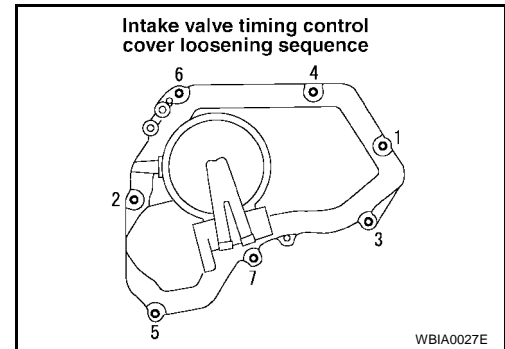

9. Set the No.1 cylinder at TDC on its compression stroke with the following procedure:
- a. Open the access cover on RH undercover.
 - b. Rotate crankshaft pulley clockwise, and align mating marks for TDC with timing indicator on front cover, as shown.

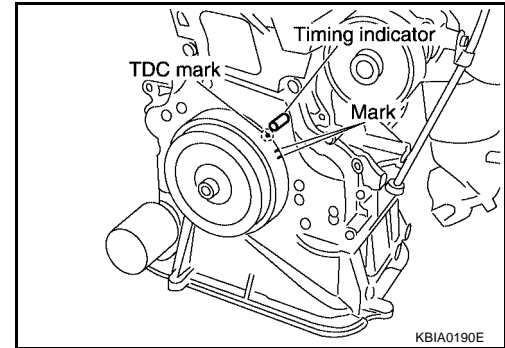

- c. At the same time, make sure that the mating marks on camshaft sprockets are lined up with the yellow links in the timing chain, as shown.
- If not, rotate crankshaft pulley one more turn to line up the mating marks to the yellow links, as shown.

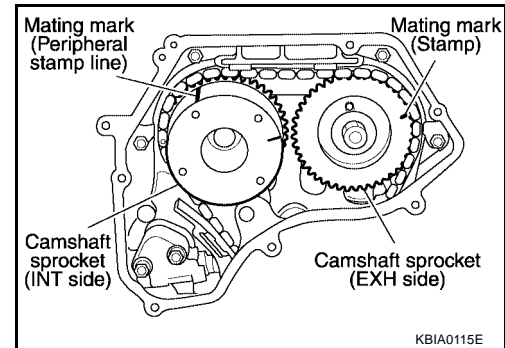

10. Pull the timing chain guide out between the camshaft sprockets through front cover.

11. Remove camshaft sprockets with the following procedure.

CAUTION:

- Do not rotate the crankshaft or camshaft while the timing chain is removed. It causes interference between valve and piston.

NOTE:

- Chain tension holding work is not necessary. Crank sprocket and timing chain do not disconnect structurally while front cover is attached.

- a. Line up the mating marks on camshaft sprockets with the yellow links in the timing chain, and paint an indelible mating mark on the sprocket and timing chain link plate.

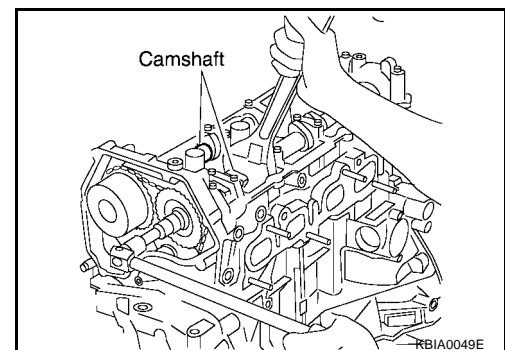

CAMSHAFT

[QR25DE]

- b. Push in the tensioner plunger and hold. Insert a stopper pin into the hole on tensioner body to hold the chain tensioner. Remove the timing chain tensioner.
 - Use a wire with 0.5 mm (0.02 in) diameter for a stopper pin.
- c. Secure the hexagonal part of camshaft with a suitable tool. Loosen the camshaft sprocket mounting bolts and remove the camshaft sprockets.

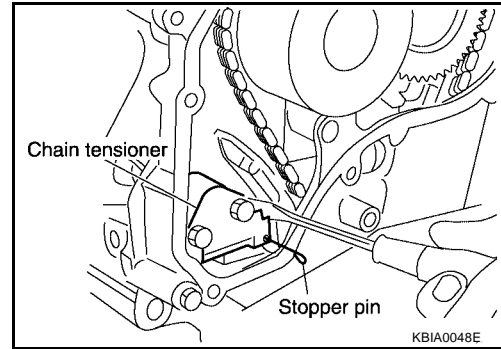

12. Loosen the camshaft bracket bolts in the order shown, and remove the camshaft brackets and camshafts.
 - Remove No.1 camshaft bracket by slightly tapping it with a rubber mallet.
13. Remove the valve lifters.
 - Check mounting positions, and set them aside in the order removed.

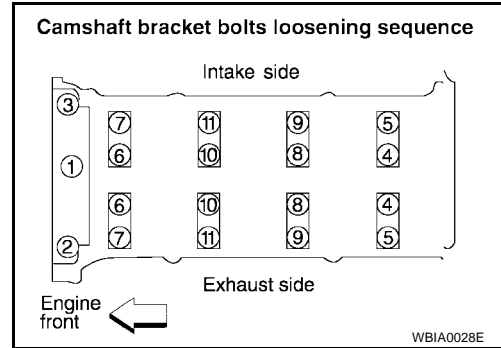

INSPECTION AFTER REMOVAL

Camshaft Runout

1. Put the camshaft on a V-block supporting the No.2 and No.5 journals.
2. Set the dial gauge vertically on the No.3 journal.
3. Turn camshaft in one direction by hand, and measure the camshaft runout on the dial gauge total indicator reading.

Standard : Less than 0.04 mm (0.0016 in)

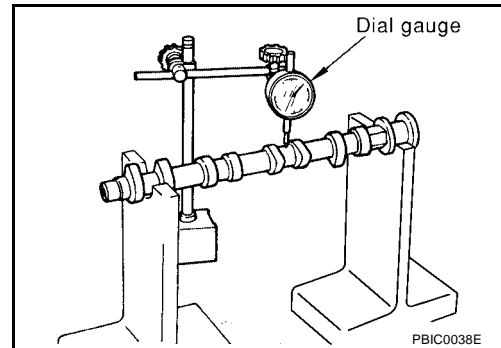

Camshaft Cam Height

1. Measure the camshaft cam height.

Standard intake cam height : 45.665 - 45.855 mm (1.7978 - 1.8053 in)

Standard exhaust cam height : 43.975 - 44.165 mm (1.7313 - 1.7388 in)

2. If wear is beyond the limit, replace the camshaft.

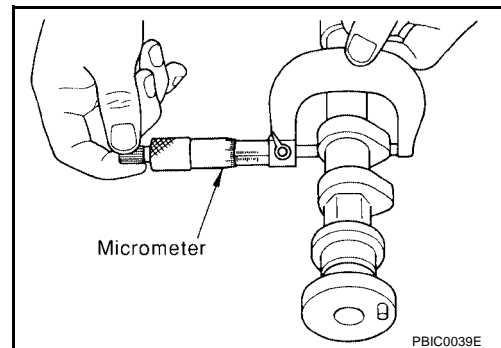

Camshaft Journal Clearance

Outer Diameter of Camshaft Journal

- Measure the outer diameter of the camshaft journal.

Standard No.1 outer diameter : 27.935 - 27.955 mm (1.0998 - 1.1006 in)

Standard No.2, 3, 4, 5, outer diameter : 23.435 - 23.455 mm (0.9226 - 0.9234 in)

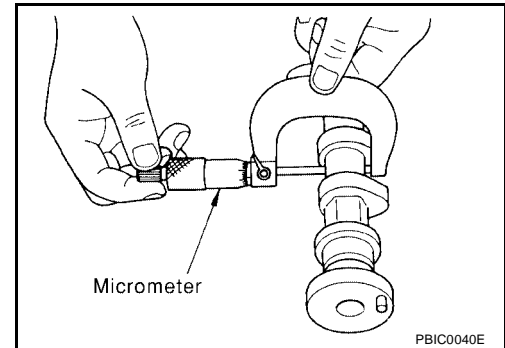

Inner Diameter of Camshaft Bracket

- Tighten the camshaft bracket bolts to the specified torque following the tightening pattern as shown. Refer to [EM-128, "INSTALLATION"](#).

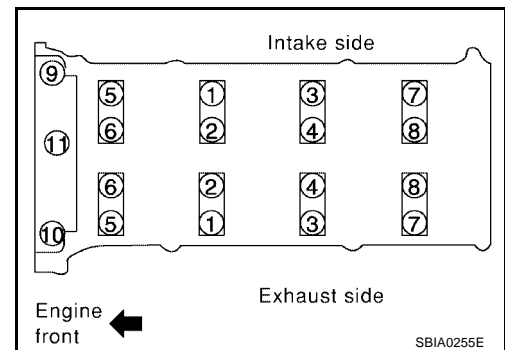

- Using inside micrometer, measure inner diameter of camshaft bracket.

Standard No.1 : 28.000 - 28.021 mm (1.1024 - 1.1032 in)

Standard No.2, 3, 4, 5 : 23.500 - 23.521 mm (0.9252 - 0.9260 in)

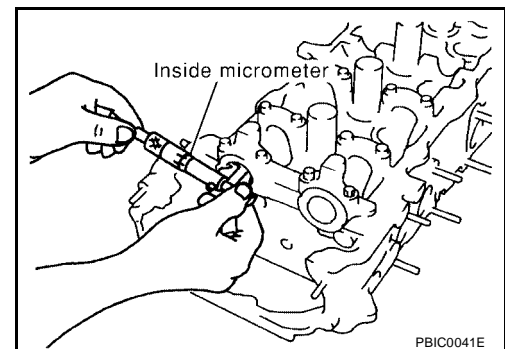

Calculation of Camshaft Journal Clearance

- (Journal clearance) = (inner diameter of camshaft bracket) – (outer diameter of camshaft journal)

Standard : 0.045 - 0.086 mm (0.0018 - 0.0034 in)

- When out of the specified range above, replace either or both the camshaft and the cylinder head assembly.

NOTE:

Inner diameter of the camshaft bracket is manufactured together with the cylinder head. If the camshaft bracket is out of specification, replace the entire cylinder head assembly.

Camshaft End Play

1. Install a dial gauge in the thrust direction on the front end of the camshaft. Measure the end play with the dial gauge while moving the camshaft forward and backward (in direction to axis).

Standard end play : 0.115 - 0.188 mm (0.0045 - 0.0074 in)

2. If out of the specified range, replace with new camshaft and measure again.
3. If out of the specified range again, replace with new cylinder head assembly.

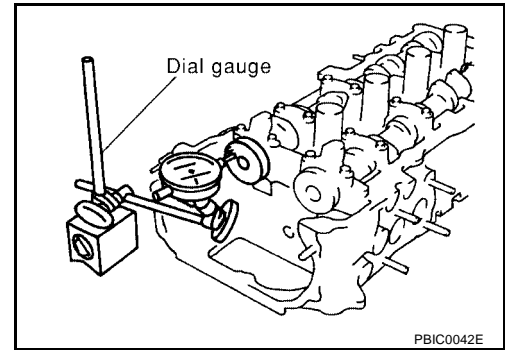

Camshaft Sprocket Runout

1. Install the camshaft in the cylinder head.
2. Install the camshaft sprocket on the camshaft.
3. Measure camshaft sprocket runout while turning the camshaft by hand.

Runout : Less than 0.15 mm (0.0059 in)

4. If it exceeds the specification, replace camshaft sprocket.

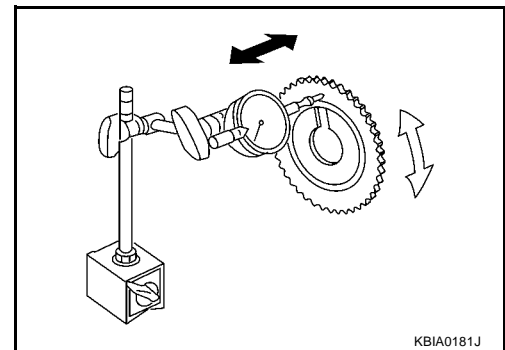

Valve Lifter

- Check if the surface of the valve lifter has any excessive wear or cracks, replace as necessary.

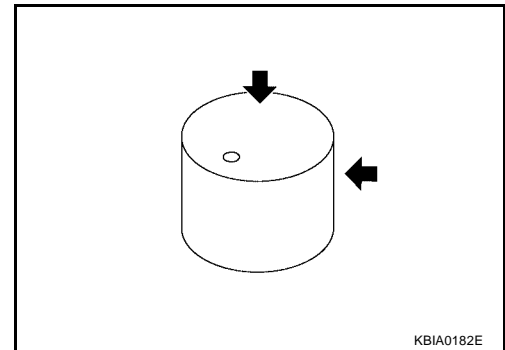

Valve Lifter Clearance

Outer Diameter of Valve Lifter

- Measure the valve lifter outer diameter.

Valve lifter outer diameter : 33.965 - 33.980 mm (1.3372 - 1.3378 in)

- If out of the specified range, replace the valve lifter.

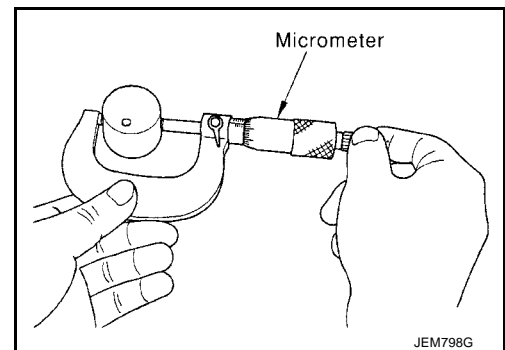

CAMSHAFT

[QR25DE]

Valve Lifter Hole Diameter

- Using inside micrometer, measure valve lifter guide bore diameter of cylinder head.

Standard : 34.000 - 34.021 mm (1.3386 - 1.3394 in)

- If out of the specified range, replace the cylinder head assembly.

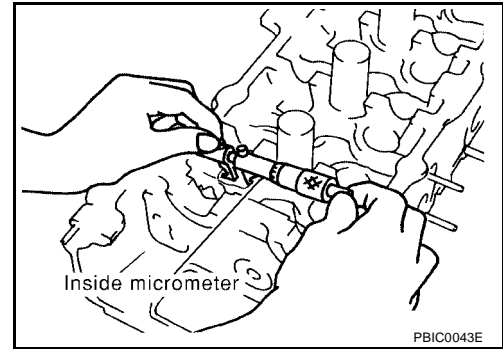

Calculation of Valve Lifter Clearance

- (Valve lifter clearance) = (valve lifter bore diameter) – (valve lifter outer diameter)

Standard : 0.020 - 0.056 mm (0.0008 - 0.0022 in)

- If out of specified range, replace either or both valve lifter and cylinder head assembly.

INSTALLATION

- Install the valve lifter.
 - Install them in the same position from which they were removed.
- Install the camshafts.
 - The distinction between the intake and exhaust camshafts is in a difference of shapes of the back end:

Intake: Signal plate for the camshaft position sensor (PHASE)

Exhaust: Cone end shape

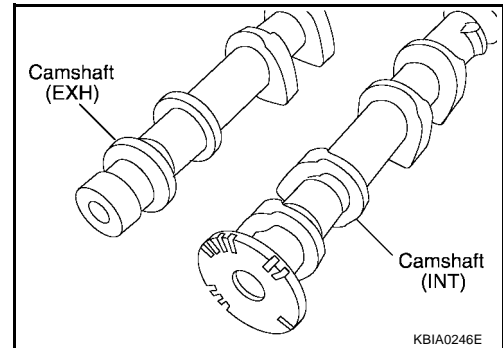

- Install camshafts so that the dowel pins on the front side are positioned as shown.

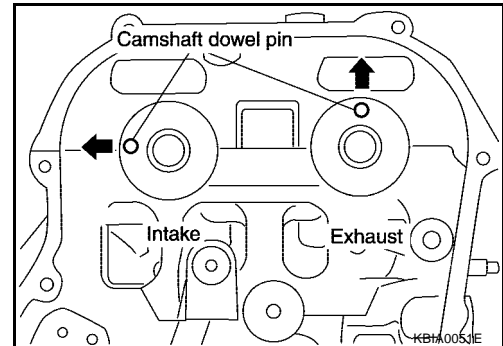

- Install camshaft brackets.
 - Install by referring to identification mark on upper surface mark.
 - Install so that identification mark can be correctly read when viewed from the exhaust side.
 - Install No. 1 camshaft bracket as follows.
 - Apply sealant to No.1 camshaft bracket as shown.

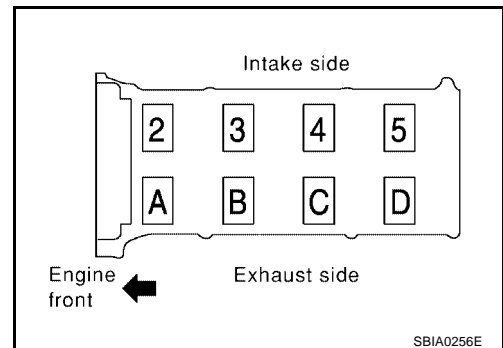

CAMSHAFT

[QR25DE]

- Use Genuine Silicone RTV Sealant, or equivalent. Refer to [GI-44, "RECOMMENDED CHEMICAL PRODUCTS AND SEALANTS"](#).

CAUTION:

- After installation, be sure to wipe off any excessive sealant leaking from part "A" (both on right and left sides).

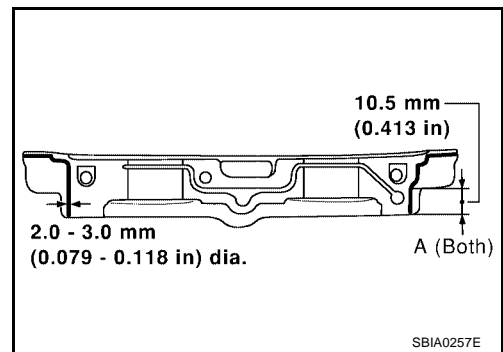

- Apply sealant to camshaft bracket contact surface on the front cover backside.
- Apply sealant to the outside of bolt hole on front cover.

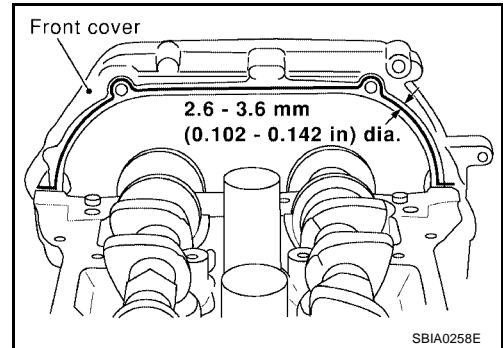

- Position the No.1 camshaft bracket near the mounting position, and install it without disturbing the sealant applied to the surfaces.

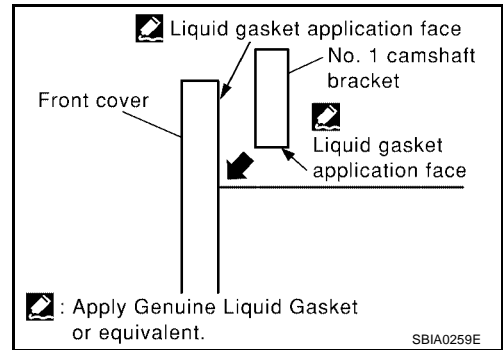

4. Tighten camshaft bracket bolts in four steps in the order shown.
 - a. Tighten in the order from 9 to 11 with tightening torque 2.0 N·m (0.2 kg·m, 17 in·lb).
 - b. Tighten in the order from 1 to 8 with tightening torque 2.0 N·m (0.2 kg·m, 17 in·lb)
 - c. Tighten all bolts in specific order with tightening torque 5.9 N·m (0.5 kg·m, 52 in·lb).
 - d. Tighten in the order from 1 to 11 with tightening torque 9.0 to 11.8 N·m (0.92 to 1.2 kg·m, 80 to 104 in·lb).

CAUTION:

After tightening camshaft bracket bolts, be sure to wipe off excessive sealant from the parts listed below.

- Mating surface of rocker cover.
- Mating surface of front cover, when installed without the front cover.

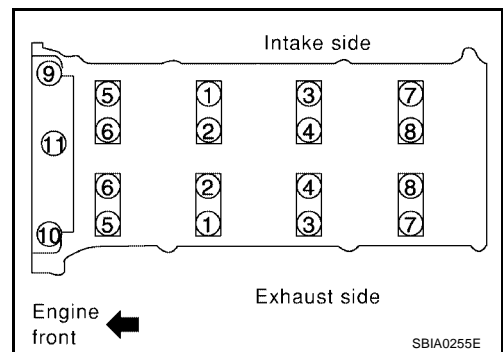

CAMSHAFT

[QR25DE]

5. Install camshaft sprockets.
 - Install them by lining up the mating marks on each camshaft sprocket with the ones painted on the timing chain during removal.
 - Before installation of chain tensioner, it is possible to re-match the marks on timing chain with the ones on each sprocket.

CAUTION:

- **Aligned mating marks could slip. Therefore, after matching them, hold the timing chain in place by hand.**
- **Before and after installing chain tensioner, check again to make sure that mating marks have not slipped.**

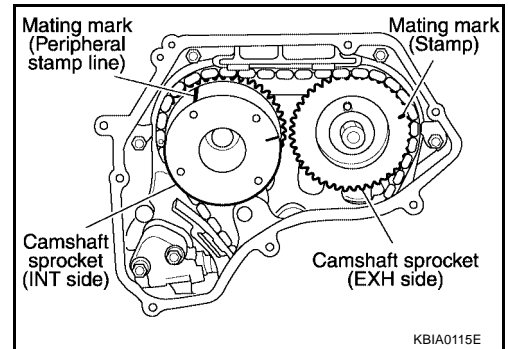

6. Install chain tensioner.

CAUTION:

After installation, pull the stopper pin off completely, and make sure that the tensioner is fully released.

7. Install chain guide.
8. Install IVT control (intake valve timing control) cover with the following procedure.
 - a. Install IVT control solenoid valve to intake valve timing control cover.
 - b. Install O-ring to front cover side.
 - c. Apply Genuine Silicone RTV Sealant to the positions shown in the figure. Refer to [GI-44, "RECOMMENDED CHEMICAL PRODUCTS AND SEALANTS"](#).

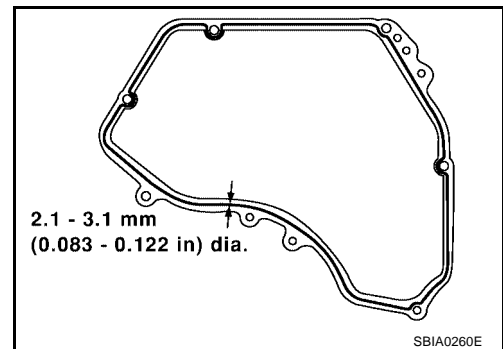

- d. Install IVT control cover.
 - Tighten the bolts in the numerical order as shown.
9. Check and adjust valve clearances. Refer to [EM-130, "Valve Clearance"](#).
10. Install the remaining components in the reverse order of removal.

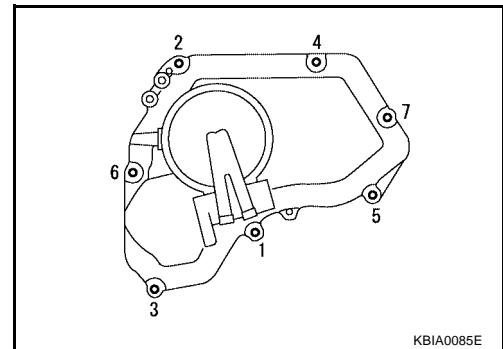

Valve Clearance INSPECTION

- Perform this inspection as follows after removal, installation, or replacement of the camshaft or any valve-related parts, or if there are any unusual engine conditions due to changes in valve clearance over time (starting, idling, and/or noise).
 1. Warm up the engine, then stop it.
 2. Remove front RH engine undercover.
 3. Remove the rocker cover.
Refer to [EM-121, "Removal and Installation"](#).

EBS00CG0

CAMSHAFT

[QR25DE]

- Turn crankshaft pulley in normal direction (clockwise when viewed from front) to align TDC identification mark (without paint mark) with timing indicator.

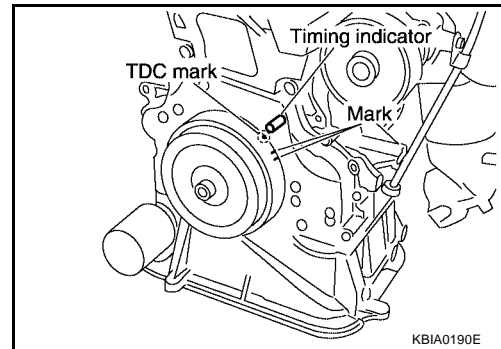

- At this time, check that both the intake and exhaust cam noses of No. 1 cylinder face outside.
 - If they do not face outside, turn crankshaft pulley once more.

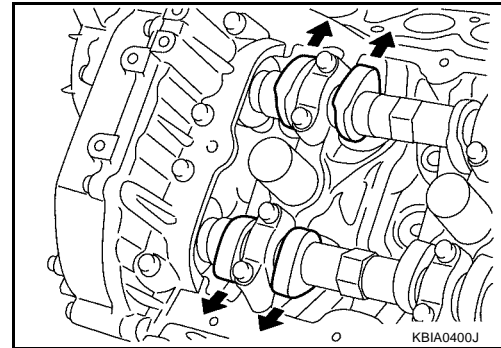

- By referring to the figure, measure valve clearances at locations marked X as shown in the table below (locations indicated with black arrow in figure) with a feeler gauge.

- No.1 cylinder compression TDC.

Cylinder	No.1		No.2		No.3		No.4	
	INT	EXH	INT	EXH	INT	EXH	INT	EXH
Measurable	×	×	×			x		

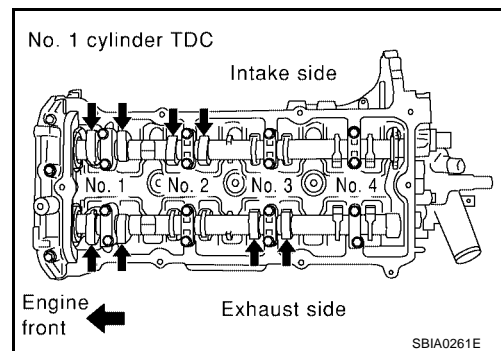

- Use a feeler gauge, measure clearance between valve and camshaft.

Valve clearance standard:

Hot	Intake	: 0.32 - 0.40 mm (0.013 - 0.016 in)
	Exhaust	: 0.33 - 0.41 mm (0.013 - 0.016 in)
Cold*	Intake	: 0.24 - 0.32 mm (0.009 - 0.013 in)
	Exhaust	: 0.26 - 0.34 mm (0.010 - 0.013 in)

*Reference data at approximately 20°C (68°F)

CAUTION:

If inspection was carried out with cold engine, check that values with fully warmed up engine are still within specifications.

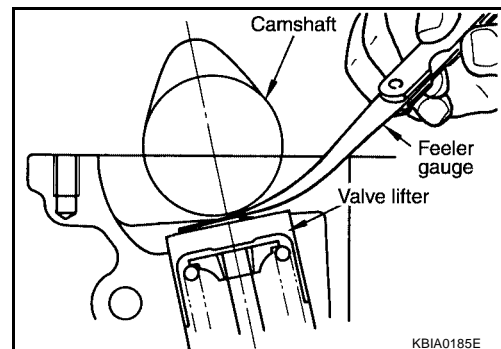

- Turn crankshaft one complete revolution (360°) and align mark on crankshaft pulley with pointer.

8. By referring to the figure, measure valve clearances at locations marked X as shown in the table below (locations indicated with black arrow in figure).

- No.4 cylinder compression TDC.

Cylinder	No.1		No.2		No.3		No.4	
Valve	INT	EXH	INT	EXH	INT	EXH	INT	EXH
Measurable				x	x		x	x

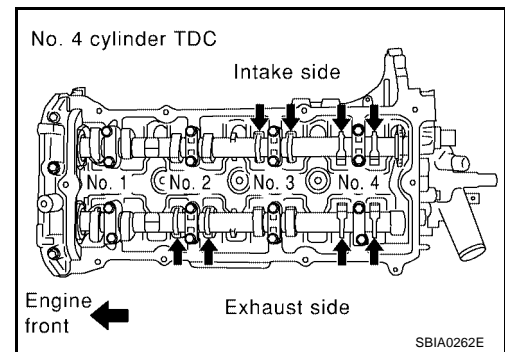

9. If out of specifications, adjust as follows.

VALVE ADJUSTMENT

- Perform adjustment depending on selected head thickness of valve lifter.
- The specified valve lifter thickness is the dimension at normal temperatures. Ignore dimensional differences caused by temperature. Use the specifications for hot engine condition to adjust.

1. Remove camshaft. Refer to [EM-123, "Removal and Installation"](#) .
2. Remove the valve lifters at the locations that are outside the standard.
3. Measure the center thickness of the removed valve lifters with a micrometer.

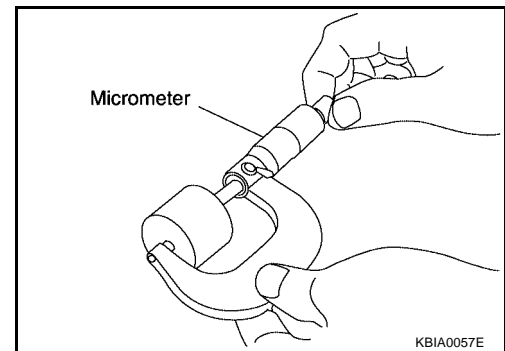

4. Use the equation below to calculate valve lifter thickness for replacement.

- Valve lifter thickness calculation.

$$t = t1 + (C1 - C2)$$

$$t = \text{Thickness of replacement valve lifter.}$$

$$t1 = \text{Thickness of removed valve lifter.}$$

$$C1 = \text{Measured valve clearance.}$$

$$C2 = \text{Standard valve clearance.}$$

- Thickness of a new valve lifter can be identified by stamp marks on the reverse side (inside the cylinder). Stamp mark 696 indicates a thickness of 6.96 mm (0.2740 in) **Available thickness of valve lifter: 26 sizes with a range of 6.96 to 7.46 mm (0.2740 to 0.2937 in), in steps of 0.02 mm (0.0008 in), when assembled at the factory.**

5. Install the selected valve lifter.
6. Install camshaft.
7. Manually turn crankshaft pulley a few turns.
8. Check that valve clearances for cold engine are within specifications, by referring to the specified values.
9. After completing the repair, check valve clearances again with the specifications for warmed engine. Use a feeler gauge to measure the clearance between the valve and camshaft. Make sure the values are within specifications.

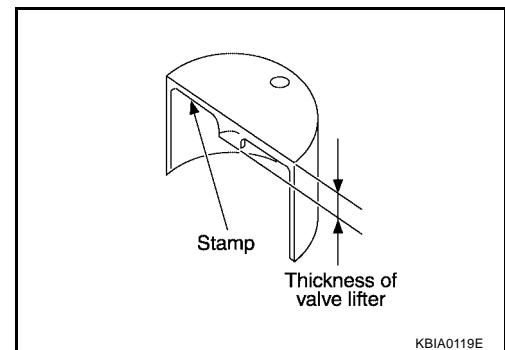

CAMSHAFT

[QR25DE]

Valve clearance:

Unit: mm (in)

	Cold* (reference data)	Hot
Intake	0.24 - 0.32 (0.009 - 0.013)	0.304 - 0.416 (0.012 - 0.016)
Exhaust	0.26 - 0.34 (0.010 - 0.013)	0.308 - 0.432 (0.012 - 0.017)

*: Reference data at approximately 20°C (68°F)

A

EM

C

D

E

F

G

H

I

J

K

L

M

TIMING CHAIN

Removal and Installation

SEC.110•112•120•130•135

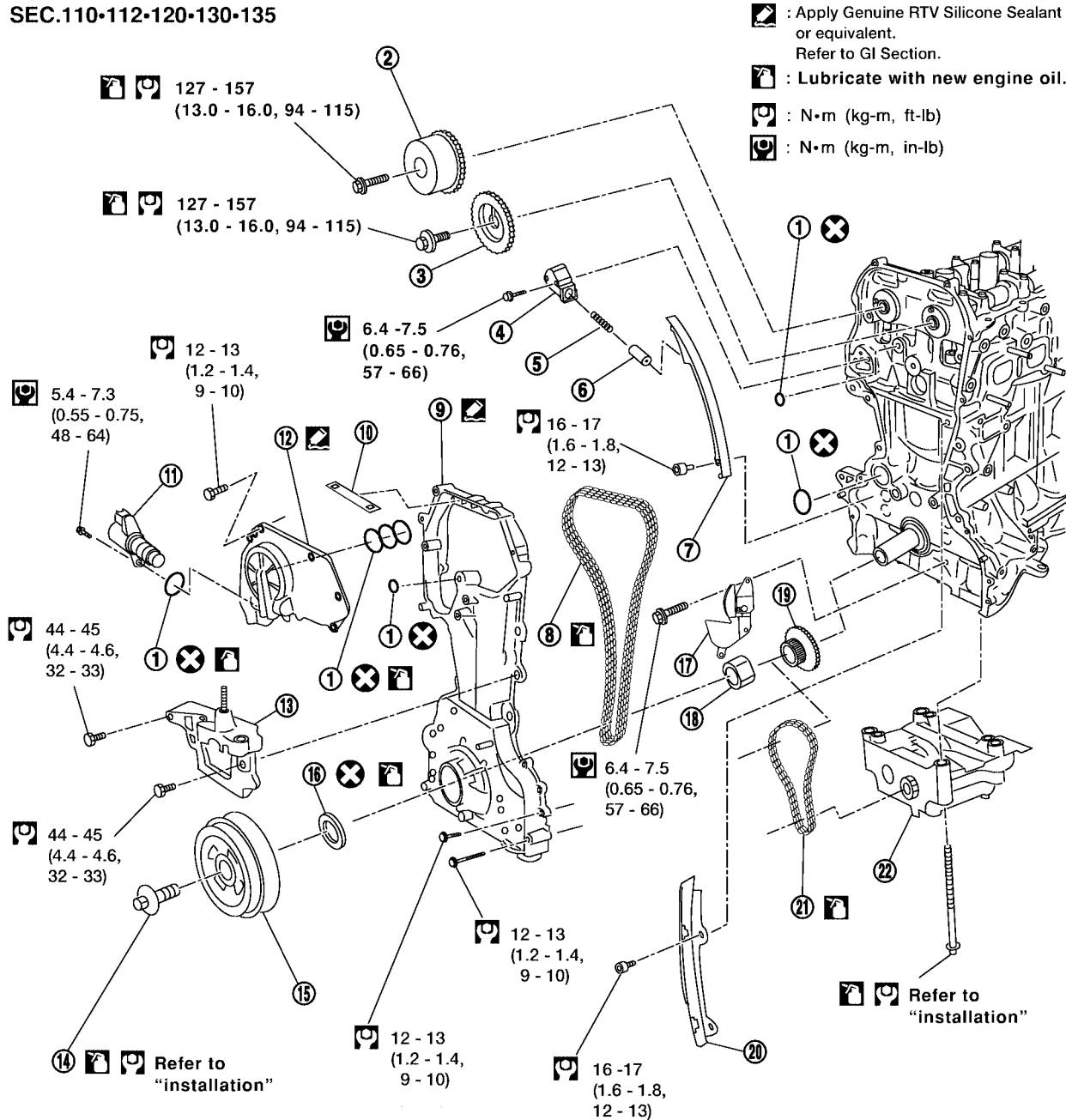

WBIA0031E

- | | | |
|-----------------------------|--|--------------------------------|
| 1. Oil rings | 2. Camshaft sprocket (INT) | 3. Camshaft sprocket (EXH) |
| 4. Chain tensioner | 5. Spring | 6. Chain tensioner plunger |
| 7. Timing chain slack guide | 8. Timing chain | 9. Front cover |
| 10. Chain guide | 11. IVT control solenoid valve | 12. IVT control cover |
| 13. Engine mounting bracket | 14. Crankshaft pulley bolt | 15. Crankshaft pulley |
| 16. Front oil seal | 17. Balancer unit timing chain tensioner | 18. Oil pump drive spacer |
| 19. Crankshaft sprocket | 20. Timing chain tension guide | 21. Balancer unit timing chain |
| 22. Balancer unit | | |

CAUTION:

Apply new engine oil to parts marked in illustration before installation.

REMOVAL

1. Release the fuel pressure. Refer to [EC-1257, "FUEL PRESSURE RELEASE"](#) .
2. Remove the air cleaner and air duct assembly. Refer to [EM-103, "Removal and Installation"](#) .
3. Remove the spark plugs. Refer to [EM-116, "Removal and Installation"](#) .
4. Remove the rocker cover. Refer to [EM-121, "Removal and Installation"](#) .
5. Remove the coolant overflow reservoir tank.
6. Remove the auxiliary drive belt auto-tensioner. Refer to [EM-101, "Removal and Installation of Drive Belt Auto-tensioner"](#) .
7. Remove the alternator. Refer to [SC-31, "Removal and Installation"](#) .
8. Remove the strut tower brace.
9. Dismount and position aside the A/C compressor with the piping attached.
10. Dismount and position aside the power steering pump and reservoir tank with the piping attached.
11. Remove the upper and lower oil pan, and oil strainer. Refer to [EM-112, "Removal and Installation"](#) .
12. Remove the IVT control (intake valve timing control) cover.
 - a. Loosen bolts in the numerical order as shown.
 - b. Remove the cover with suitable tool to cut the sealant.
13. Pull chain guide between camshaft sprockets out through front cover.

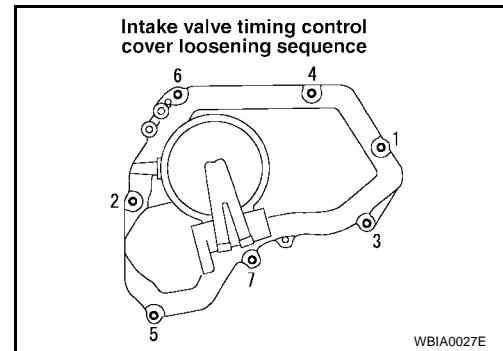

14. Set the No.1 cylinder at TDC on the compression stroke with the following procedure:
 - a. Rotate the crankshaft pulley clockwise and align the mating marks to the timing indicator on the front cover.

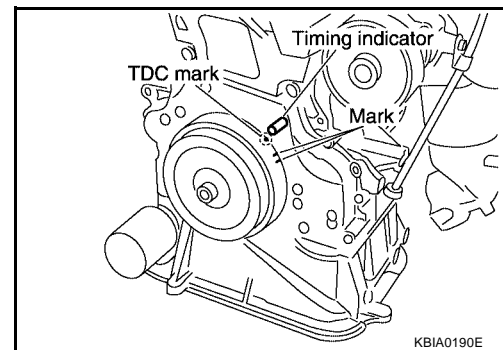

- b. At the same time, make sure that the mating marks on the camshaft sprockets are lined up as shown.
 - If not lined up, rotate the crankshaft pulley one more turn to line up the mating marks to the positions as shown.

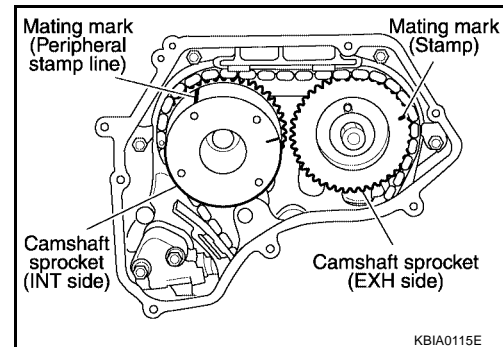

TIMING CHAIN

[QR25DE]

15. Remove crankshaft pulley with the following procedure:

- a. Hold the crankshaft pulley with a suitable tool, then loosen the crankshaft pulley mounting bolt, and pull the pulley out about 10 mm (0.39 in). Remove the crankshaft pulley mounting bolt.

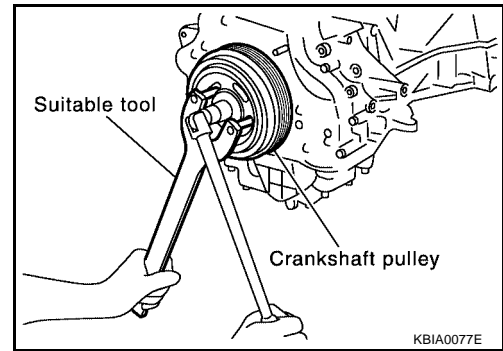

- b. Attach a pulley puller in the M 6 (0.24 in diameter) thread hole on crankshaft pulley, and remove crankshaft pulley.

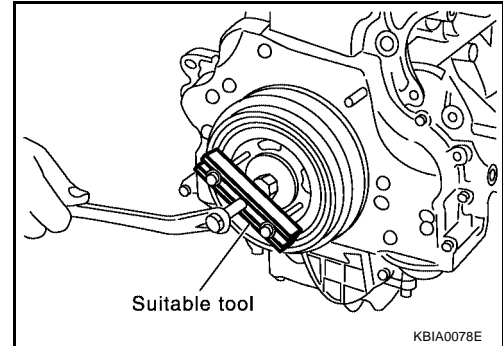

16. Remove the front cover with the following procedure:

- a. Loosen the mounting bolts in the numerical order as shown, and remove them.
- b. Remove the front cover.

CAUTION:

- Be careful not to damage the mounting surface.

17. If the front oil seal needs to be replaced, lift it out with a screwdriver to remove it.

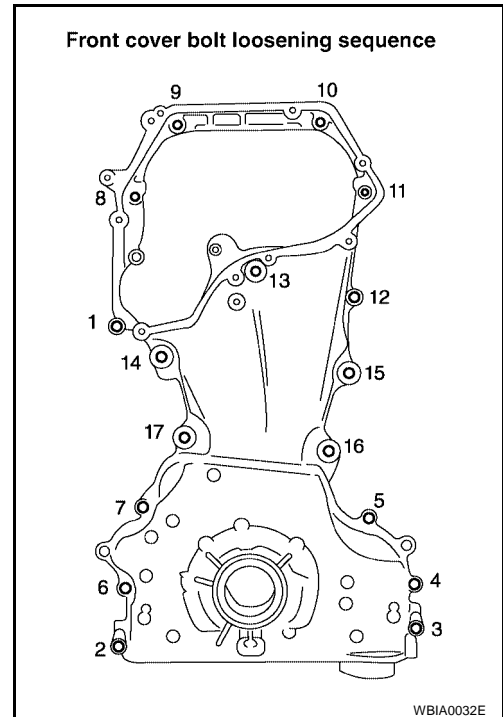

18. Remove timing chain with the following procedure:

- a. Push in the tensioner plunger. Insert a stopper pin into the hole on the tensioner body to hold the chain tensioner.
 - Use a wire of 0.5 mm (0.02 in) diameter as a stopper pin.
- b. Remove the chain tensioner.

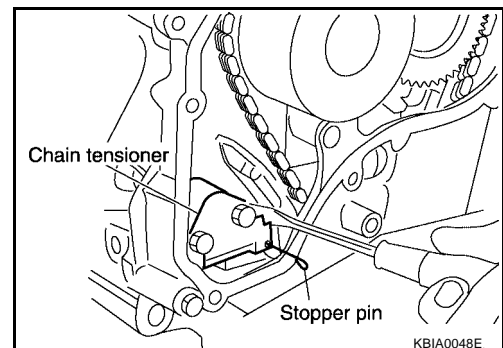

TIMING CHAIN

[QR25DE]

- c. Secure hexagonal part of the camshaft with a wrench and loosen the camshaft sprocket mounting bolt and remove the camshaft sprocket for both camshafts.

CAUTION:

- Do not rotate the crankshaft or camshafts while the timing chain is removed. It can cause damage to the valve and piston.

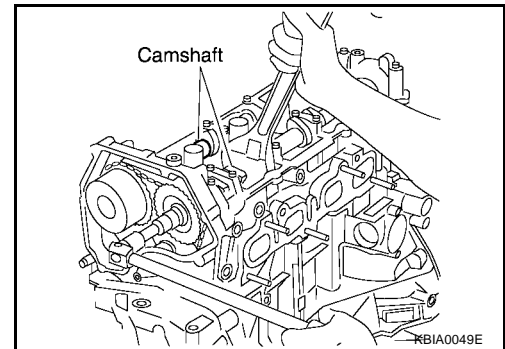

19. Remove the chain slack guide, tension guide, timing chain, and oil pump drive spacer.

20. Remove the timing chain tensioner for the balancer unit with the following procedure:

- Lift the tensioner lever up, and release the ratchet claw.
- Push tensioner sleeve in, and hold it.
- Matching the hole on lever with the one on body, insert a stopper pin to secure tensioner sleeve.
- Remove the timing chain tensioner for the balancer unit.

21. Remove timing chain for balancer unit and crankshaft sprocket.

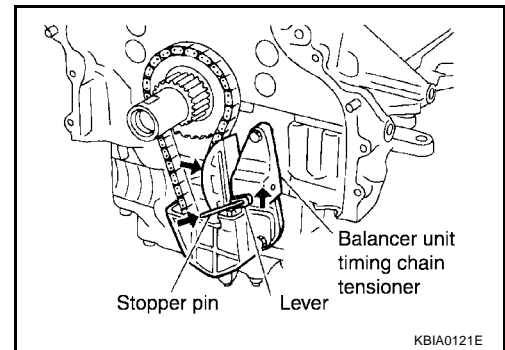

22. Loosen mounting bolts in reverse order shown in the figure, and remove balancer unit.

- Use Torx socket (size E14)

CAUTION:

- Do not disassemble balancer unit.

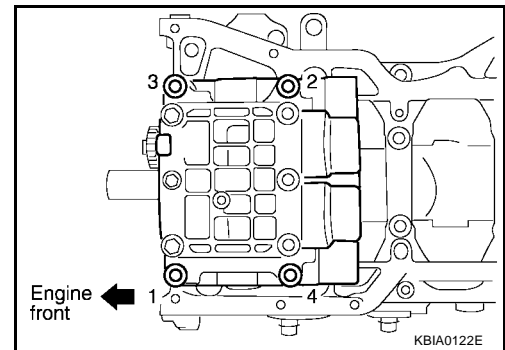

INSPECTION AFTER REMOVAL

Timing Chain

Check the timing chain for cracks or serious wear. If a defect is detected, replace it.

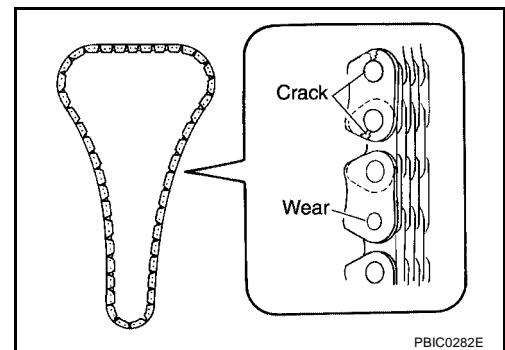

A
EM
C
D
E
F
G
H
I
J
K
L
M

Balancer Unit Mounting Bolt Outer Diameter

- Measure outer diameters (d1, d2) at the two positions shown in the figure.
- Measure d2 within the range A.
- If the value difference (d1 - d2) exceeds the limit (a dimension difference is large), replace it with a new one.

Limit : 0.15 mm (0.0059 in) or more

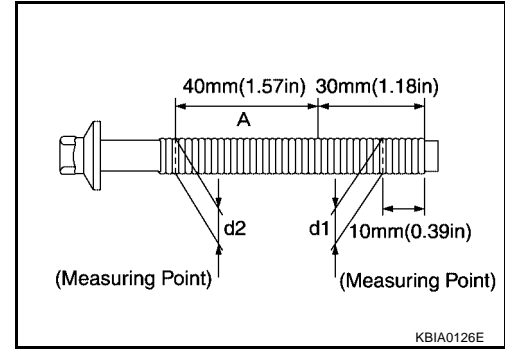

INSTALLATION

NOTE:

- There may be two color variations of the link marks (link colors) on the timing chain.
- There are 26 links between the gold/yellow mating marks on the timing chain; and 64 links between the camshaft sprocket gold/yellow link and the crankshaft sprocket orange/blue link, on the timing chain side without the tensioner.

1. Make sure the crankshaft key points straight up.
2. Install the balancer unit and tighten the mounting bolts in the numerical order shown with the following procedure:

CAUTION:

- **When reusing a mounting bolt, check its outer diameter before installation. Refer to [EM-138, "Balancer Unit Mounting Bolt Outer Diameter"](#).**

- a. Apply new engine oil to threads and seating surfaces of mounting bolts.
- b. Tighten them to 45.2 - 51.0 N·m (4.6 - 5.2 kg·m, 34 - 37 ft·lb).
- c. Turn them another 90° - 95° degrees (Target: 90° degrees).
- d. Fully loosen in the reverse order of tightening to 0 N·m (0 kg·m, 0 ft·lb).
- e. Tighten them to 45.2 - 51.0 N·m (4.6 - 5.2 kg·m, 34 - 37 ft·lb).
- f. Turn them another 90° - 95° degrees (Target: 90° degrees).

CAUTION:

- **Check tightening angle with an angle wrench or a protractor. Do not make judgment by visual check alone.**

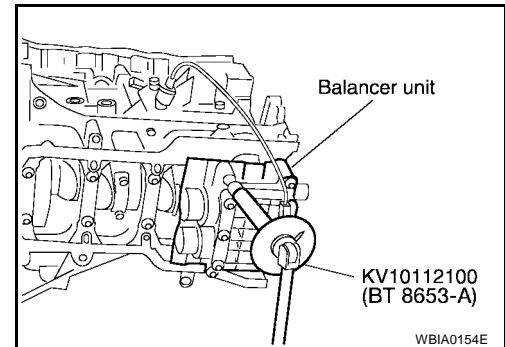
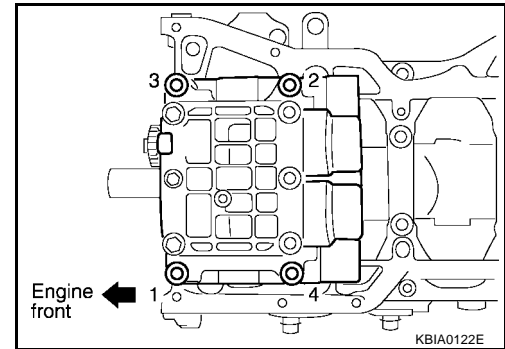

3. Install the crankshaft sprocket and timing chain for the balancer unit.

- Make sure that the crankshaft sprocket is positioned with mating marks on the block and sprocket meeting at the top.
- Install it by lining up mating marks on each sprocket and timing chain.

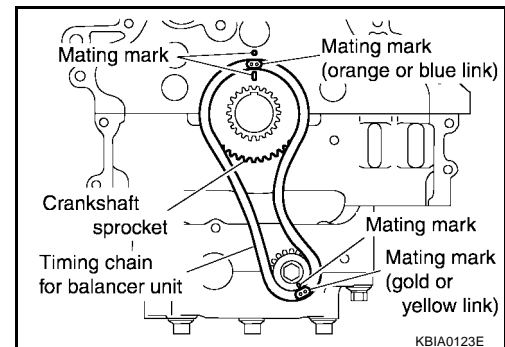

TIMING CHAIN

[QR25DE]

4. Install timing chain tensioner for balancer unit.

NOTE:

Chain guide and tensioner move freely with the caulking pin as the axle. Therefore, bolt hole position of the three points could be changed during removal. If points change, temporarily fix the two mounting bolts on the chain guide and move the tensioner to match the bolt holes.

- Be careful not to let mating marks of each sprocket and timing chain slip.
- After installation, make sure the mating marks have not slipped, then remove stopper pin and release tensioner.

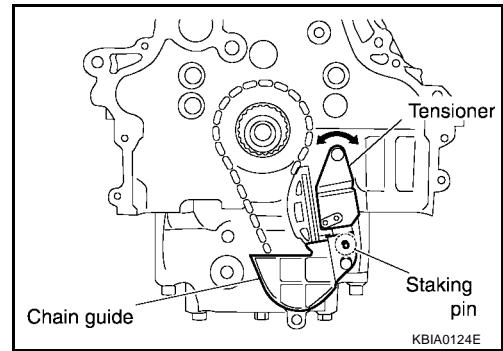

5. Install timing chain and related parts.

- Install by lining up mating marks on each sprocket and timing chain as shown.

NOTE:

Before installing chain tensioner, it is possible to change the position of mating mark on timing chain for that of each sprocket for alignment.

CAUTION:

For the above reason, after the mating marks are aligned, keep them aligned by holding them with a hand.

- Before and after installing chain tensioner, check again to make sure that mating marks have not slipped.
- After installing chain tensioner, remove stopper pin, and make sure the tensioner moves freely.
- To avoid skipped teeth, do not move crankshaft and camshaft until front cover is installed.

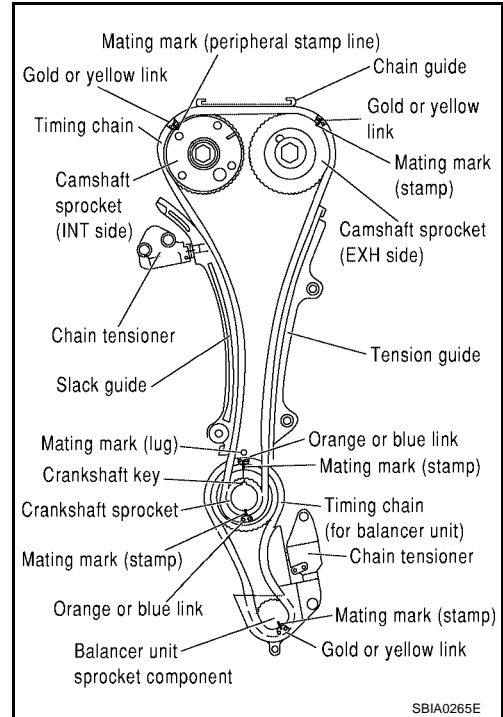

6. Install front oil seal to front cover.

- Using a drift of 56 mm (2.20 in) diameter, press oil seal in until it is flush with front end surface of front cover.

CAUTION:

- Be careful not to cause damage to circumference of oil seal.

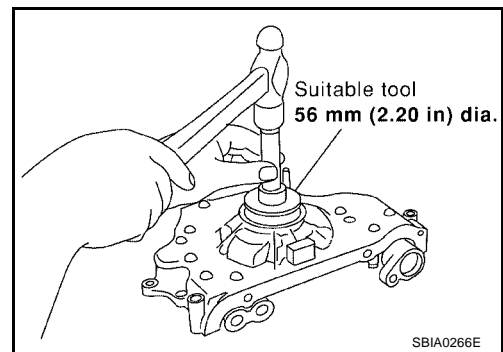

TIMING CHAIN

[QR25DE]

7. Install front cover with the following procedure:
 - a. Install O-rings to cylinder head and cylinder block.
 - b. Apply Genuine Silicone RTV Sealant or equivalent, to positions specified in the figure. Refer to [GI-44, "RECOMMENDED CHEMICAL PRODUCTS AND SEALANTS"](#).
 - c. Make sure the mating marks on the timing chain and each sprocket are still aligned. Then install the front cover.

CAUTION:

- Be careful not to damage the front oil seal during installation with the front end of the crankshaft.

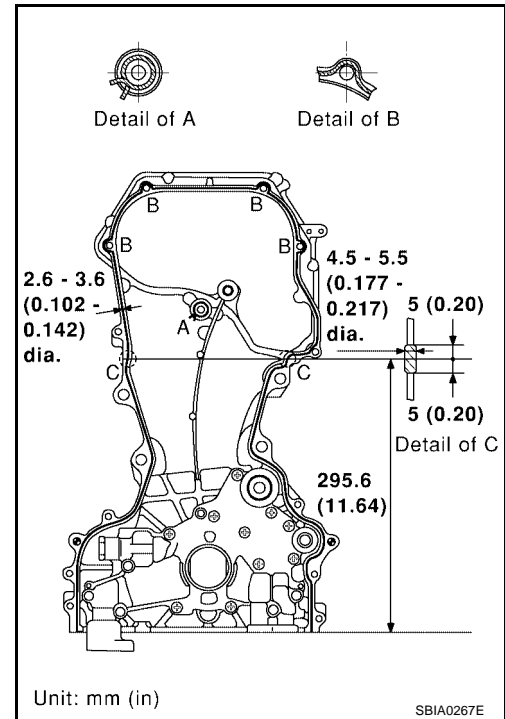

- d. Tighten mounting bolts in the numerical order as shown.
- e. After all bolts are tightened, retighten them to the specified torque.

Front cover bolts : 12 - 13 N·m (1.2 - 1.4 kg·m, 9 - 10 ft-lb)

CAUTION:

Wipe off any excess sealant leaking at the surface for installing the oil pan.

8. Install the chain guide between the camshaft sprockets.

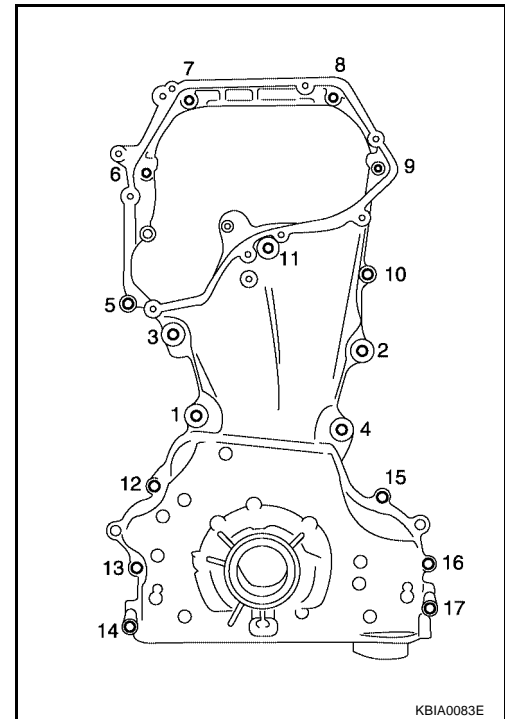

9. Install IVT control cover with the following procedure:
 - a. Install IVT control solenoid valves to IVT control cover.
 - b. Install oil rings to the intake camshaft sprocket insertion points on IVT control backside cover.
 - c. Install O-ring to front cover.

TIMING CHAIN

[QR25DE]

d. Apply Silicone RTV Sealant to the positions as shown.

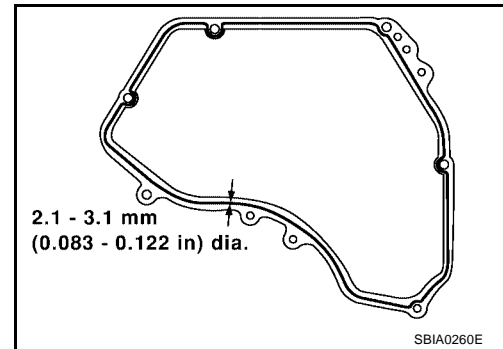

e. Tighten the mounting bolts in the numerical order as shown.

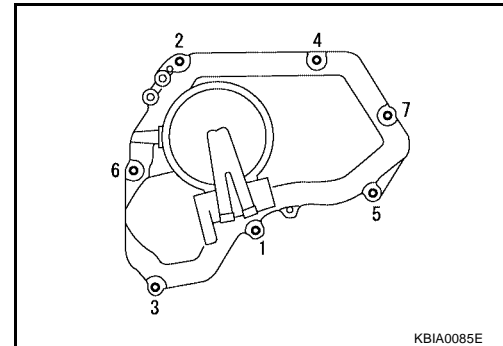

10. Insert crankshaft pulley by aligning with crankshaft key.

- Tap its center with a plastic hammer to insert.

11. Tighten crankshaft pulley mounting bolts.

- Secure crankshaft pulley with a pulley holder to tighten the bolt.
- Perform angle tightening with the following procedure:

- Apply new engine oil to threads and seat surfaces of mounting bolts.
- Tighten to initial specifications:-

Crankshaft pulley bolt initial tightening : 37.3 - 47.1 N·m (3.8 - 4.8 kg·m, 28 - 34 ft-lb)

c. Apply a paint mark on the front cover, mating with any one of six easy to recognize stamp marks on bolt flange.

d. Turn crankshaft pulley bolt another 60° to 66° degrees [Target: 60° degrees].

- Check vertical mounting angle with movement of one stamp mark.

12. Installation of the remaining parts is in reverse order of removal.

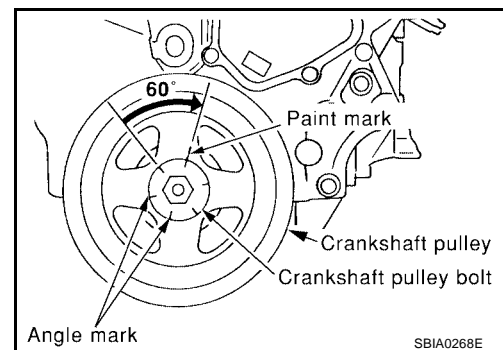

OIL SEAL**Removal and installation of Valve Oil Seal
REMOVAL**

1. Remove camshaft. Refer to [EM-123, "REMOVAL"](#)
2. Remove valve lifter. Refer to [EM-123, "REMOVAL"](#) .
3. Rotate crankshaft, and set piston whose oil seal is to be removed to top dead center. This prevents valve from dropping inside cylinder.

CAUTION:

When rotating crankshaft, be careful to avoid scarring the front cover with the timing chain.

4. Remove valve collet, valve spring retainer and valve spring with Tool.

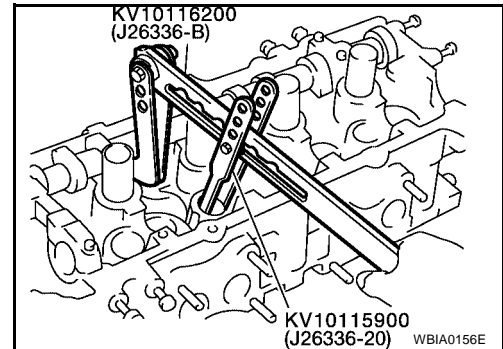

5. Remove valve oil seal with Tool.

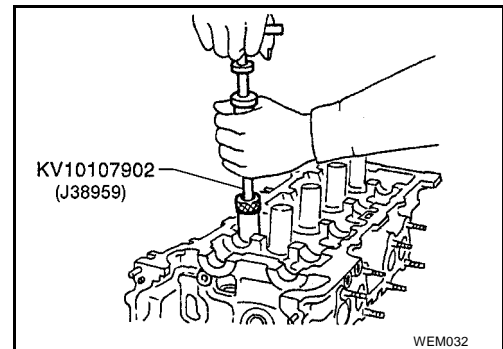

6. Installation of the remaining components is in reverse order of removal.

INSTALLATION

1. Apply new engine oil to new valve oil seal joint surface and seal lip.
2. Press in valve oil seal to the position shown with Tool.

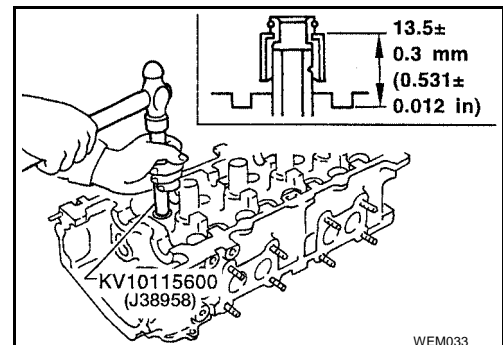
**Removal and Installation of Front Oil Seal
REMOVAL**

1. Remove the following parts:
 - Engine under cover
 - Drive belts. Refer to [EM-100, "REMOVAL"](#) .
 - Crankshaft pulley. Refer to [EM-134, "TIMING CHAIN"](#)
2. Remove front oil seal from front cover.

CAUTION:

Be careful not to scratch front cover.

INSTALLATION

1. Apply new engine oil to new oil seal and install it using a suitable tool.
 - Install new oil seal in the direction shown.

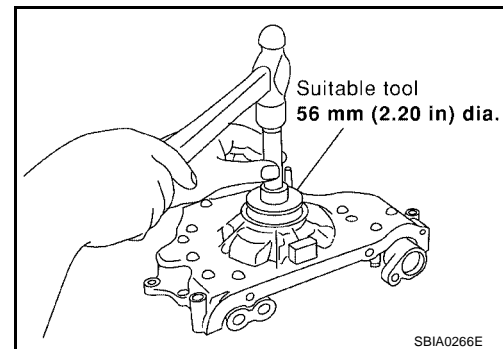
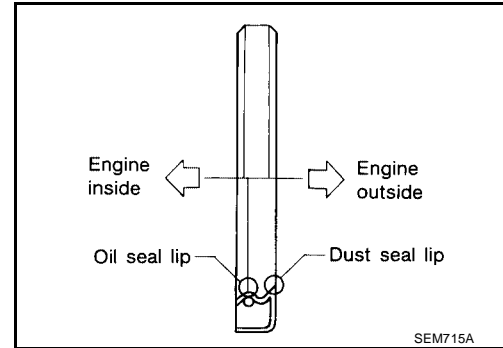

2. Installation of the remaining components is in reverse order of removal.

A

EM

C

D

E

F

G

H

I

J

K

L

M

Removal and Installation of Rear Oil Seal

REMOVAL

1. Remove the transaxle. Refer to [MT-16, "Removal and Installation"](#) (RS5F70A), [MT-82, "Removal and Installation"](#) (RS5F51A), [MT-143, "Removal and Installation"](#) (RS6F51H), or [AT-265, "REMOVAL AND INSTALLATION"](#) (RE4F03B), [AT-649, "REMOVAL AND INSTALLATION"](#) (RE4F04B).
2. Remove flywheel (MT) or drive plate (AT).
3. Remove rear oil seal.
 - Be careful not to damage crankshaft and/or cylinder block.

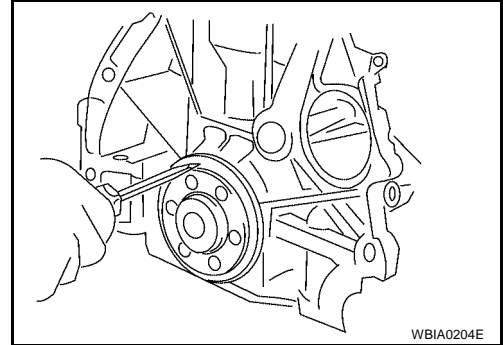

INSTALLATION

1. Apply new engine oil to new oil seal and install it using a suitable tool.
 - Install new oil seal in the direction shown.

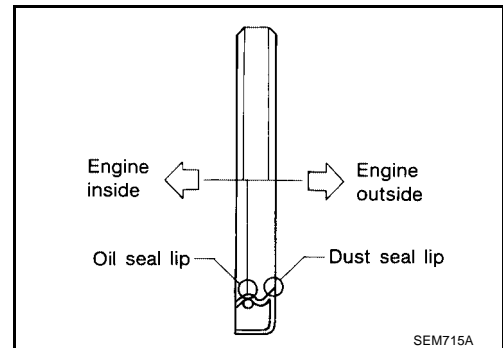

2. Install rear oil seal with a suitable drift.

CAUTION:

- Do not touch grease applied onto oil seal lip.
- Be careful not to damage crankshaft and/or cylinder block.
- Press fit oil seal straight to avoid causing burrs or tilting.

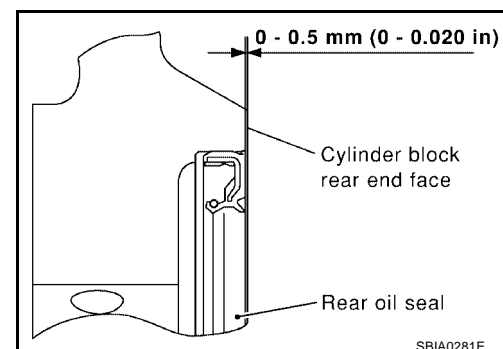
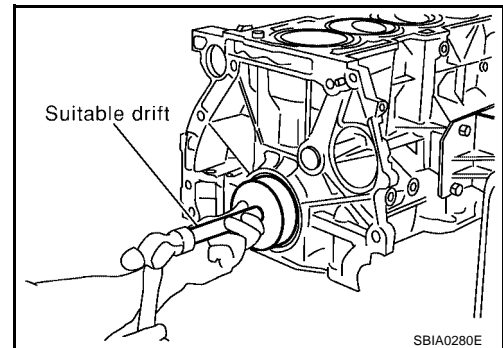

3. Installation of the remaining components is in reverse order of removal.

CYLINDER HEAD

On-Vehicle Service

CHECKING COMPRESSION PRESSURE

1. Warm up the engine to full operating temperature.
2. Turn ignition switch OFF.
3. Release the fuel pressure. Refer to [EC-1257, "FUEL PRESSURE RELEASE"](#) .
4. Remove the ignition coil and spark plug from each cylinder. Refer to [EM-116, "Removal and Installation"](#) .
5. Connect engine tachometer (not required in use of CONSULT-II).
6. Disconnect the fuel injector harness connector to avoid any residual fuel injection during the measurement.
7. Install the compression tester with the adapter into the spark plug hole.

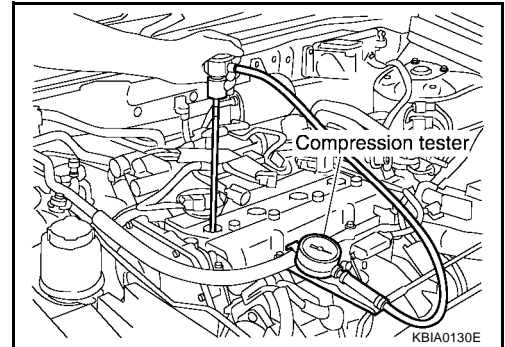

- Use compression gauge whose picking up end inserted to spark plug hole is smaller than 20 mm (0.79 in) in diameter. Otherwise, it may be caught by cylinder head during removal.

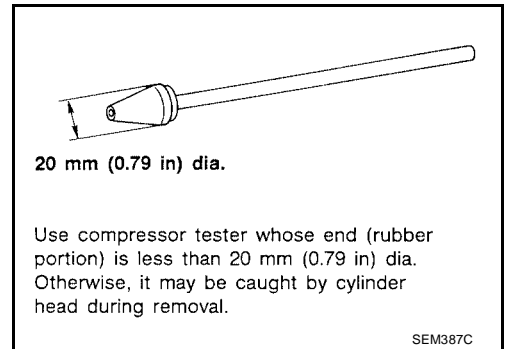

8. With the accelerator pedal fully depressed, turn the ignition switch to the "START" position to crank over the engine. When the gauge pointer stabilizes, read the compression pressure and engine rpm. Perform these steps to check each cylinder.

Unit: kPa (kg/cm² , psi) / rpm

Standard	Minimum	Difference limit between cylinders
1,250 (12.8, 181.3) / 250	1,060 (10.8, 153.7) / 250	100 (1.0, 14) / 250

CAUTION:

Always use a fully charged battery to obtain specified engine cranking speed.

- If the engine speed is out of specified rpm range, check the battery. Check engine speed again with a fully charged battery.
- If compression pressure is below minimum value, check valve clearances and parts associated with combustion chamber (valve, valve seat, piston, piston ring, cylinder bore, cylinder head, cylinder head gasket). After the checking, measure compression pressure again.
- If some cylinders have low compression pressure, pour small amount of engine oil into the spark plug hole of the cylinder to re-check it for compression.
 - If the added engine oil improves the compression, the piston rings may be worn or damaged. Check the piston rings and replace if necessary.

CYLINDER HEAD

[QR25DE]

-
- If the compression pressure remains at low level despite the addition of engine oil, the valves may be malfunctioning. Check the valves for damage. Replace the valve or valve seat accordingly.
 - If two adjacent cylinders have respectively low compression pressure and their compression remains low even after the addition of engine oil, the head gasket is leaking. In such a case, replace the cylinder head gasket.
9. Install spark plug, ignition coil and harness connectors.

CYLINDER HEAD

[QR25DE]

Removal and Installation

EBS00CG3

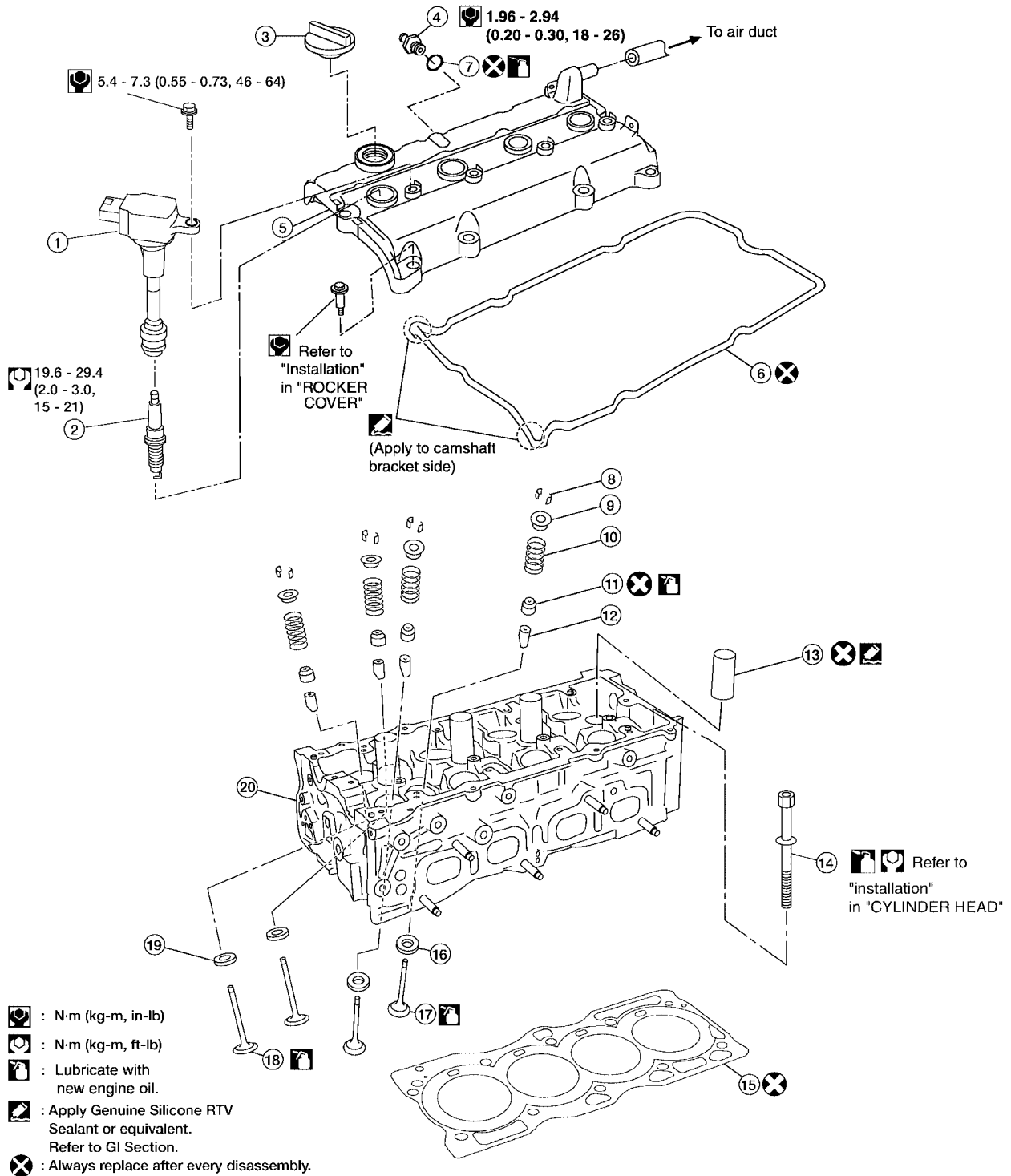

- | | | |
|---------------------|------------------------|--------------------------|
| 1. Ignition coil | 2. Spark plug | 3. Oil filler cap |
| 4. PCV valve | 5. Rocker cover | 6. Rocker cover gasket |
| 7. O-ring | 8. Valve collet | 9. Valve spring retainer |
| 10. Valve spring | 11. Valve oil seal | 12. Valve guide |
| 13. Spark plug tube | 14. Cylinder head bolt | 15. Cylinder head gasket |

WBIA0225E

- 16. Valve seat (EXH)
- 19. Valve seat (INT)

- 17. Valve (EXH)
- 20. Cylinder head

- 18. Valve (INT)

REMOVAL

1. Release fuel pressure. Refer to [EC-1257, "FUEL PRESSURE RELEASE"](#) .
2. Remove the strut tower brace.
3. Drain engine coolant and engine oil. Refer to [MA-16, "DRAINING ENGINE COOLANT"](#) , [MA-20, "Changing Engine Oil"](#) .
4. Remove the engine undercovers.
5. Remove the timing chain. Refer to [EM-134, "Removal and Installation"](#) .
6. Remove the camshafts. Refer to [EM-123, "CAMSHAFT"](#) .
7. Remove the exhaust manifold. Refer to [EM-110, "REMOVAL"](#) .
8. Support the engine with suitable hoist and floor jack.
9. Remove cylinder head loosening bolts in the numerical order as shown.
10. If necessary to transfer to new cylinder head or remove for reconditioning, remove the intake manifold collector, intake manifold, and fuel tube assembly. Refer to [EM-105, "Removal and Installation"](#) .

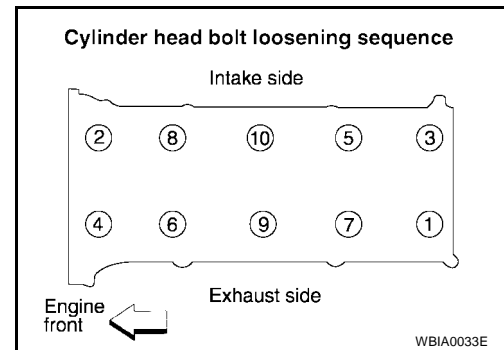

INSPECTION AFTER REMOVAL

Outer Diameter of Cylinder Head Bolts

- Cylinder head bolts are tightened by plastic zone tightening method. Whenever the size difference between d1 and d2 exceeds the limit, replace the bolts with new ones.
 - Limit (d1 - d2) : 0.23 mm (0.0091 in) or less**
- If reduction of outer diameter appears in a position other than d2, use it as d2 point.

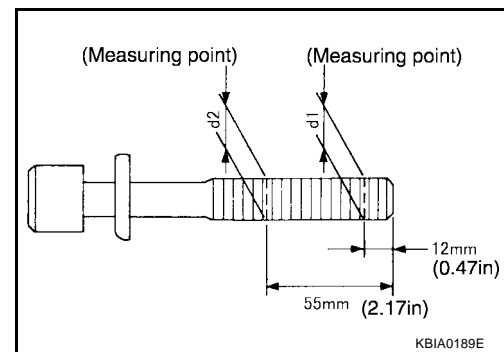

INSTALLATION

1. Install a new cylinder head gasket.
2. Follow the steps below to tighten the cylinder head bolts in the numerical order as shown.

CAUTION:

- **If cylinder head bolts are re-used, check their outer diameters before installation. Refer to [EM-148, "Outer Diameter of Cylinder Head Bolts"](#) .**
- Apply new engine oil to the threads and the seating surfaces of mounting bolts.

Cylinder head bolts

- Step 1 : 98.1 N·m (10 kg-m, 72 ft-lb)**
- Step 2 : 0 N·m (0 kg-m, 0 ft-lb) (loosen)**
- Step 3 : 34.3 - 44.1 N·m (3.5 - 4.4 kg-m, 26 - 32 ft-lb)**
- Step 4 : 75° - 80° (target: 75°) clockwise**
- Phase 5 : 75° - 80° (target: 75°) clockwise**

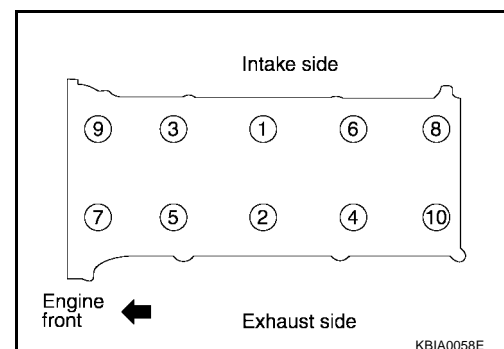

CYLINDER HEAD

[QR25DE]

Cylinder head bolt loosening sequence

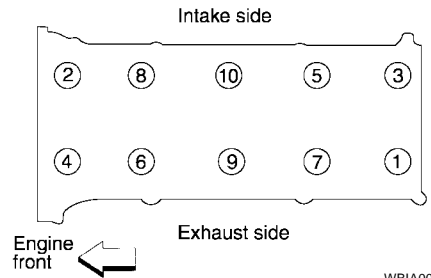

CAUTION:

Check and confirm the tightening angle by using an angle wrench or protractor. Avoid judgement by visual inspection without the tool.

- Installation of the remaining components is in reverse order of removal.

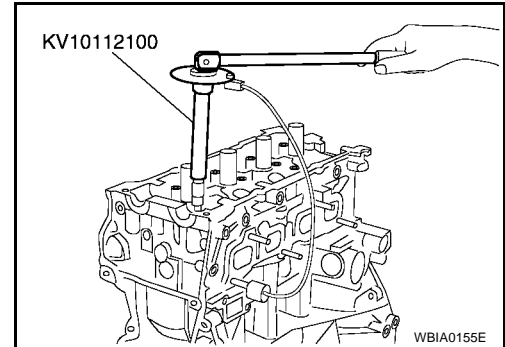

Disassembly and Assembly

EBS00CG4

SEC. 111•130•220

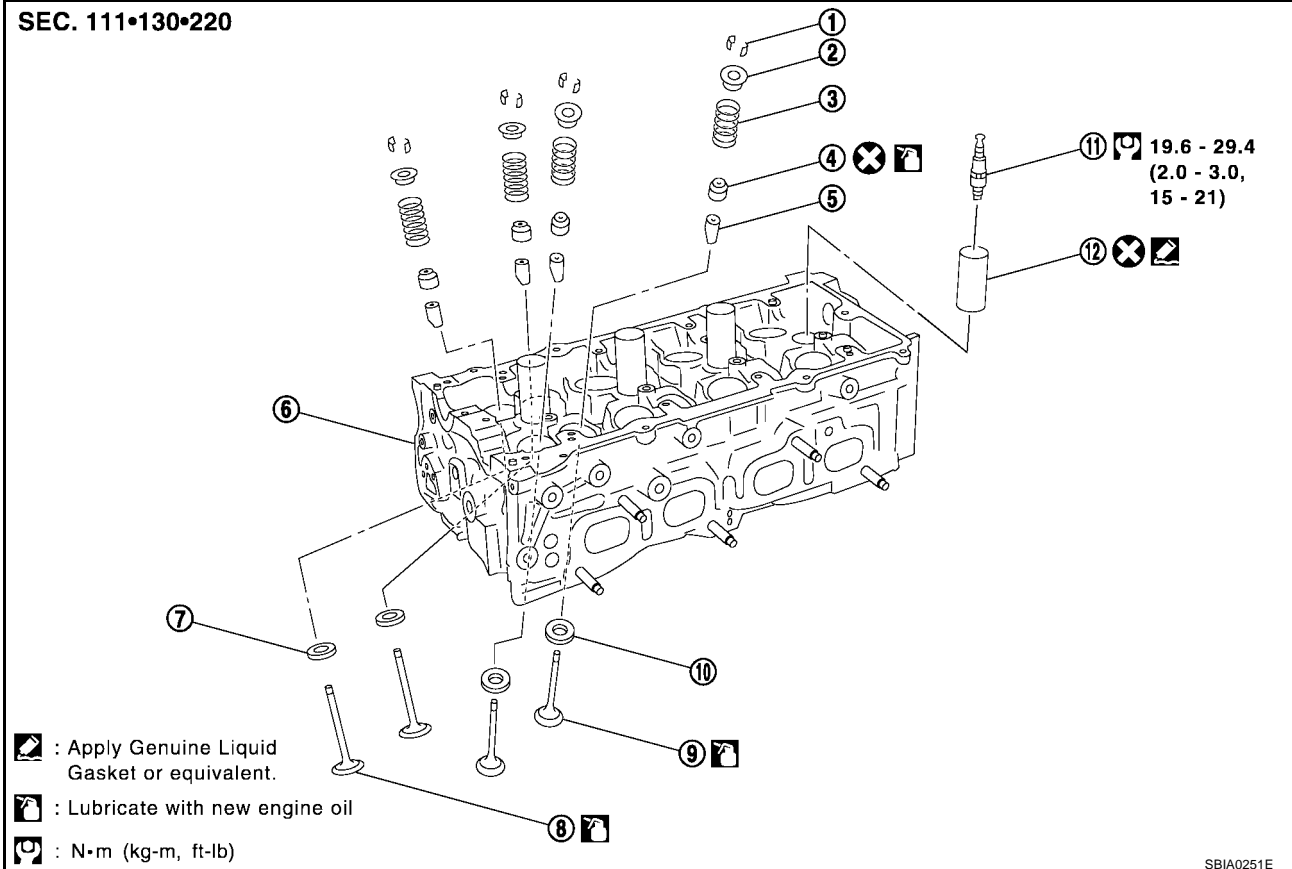

- | | | |
|----------------------|--------------------------|--|
| 1. Valve collet | 2. Valve spring retainer | 3. Valve spring (with valve spring seat) |
| 4. Valve oil seal | 5. Valve guide | 6. Cylinder head |
| 7. Valve seat (INT) | 8. Valve (INT) | 9. Valve (EXH) |
| 10. Valve seat (EXH) | 11. Spark plug | 12. Spark plug tube |

CAUTION:

- When installing camshafts, chain tensioners, oil seals or other sliding parts, lubricate contacting surfaces with new engine oil.
- Apply new engine oil to threads and seat surfaces when installing the cylinder head, camshaft sprocket, crankshaft pulley and camshaft bracket.
- Attach tags to valve lifters so all parts are assembled in their original position.

DISASSEMBLY

1. Remove the valve lifter.
 - Note installation point.
2. Remove the valve collet.
 - Compress valve spring with valve spring compressor. Remove valve collet with magnet driver.
3. Remove valve spring retainer and valve spring.

CAUTION:

Do not remove valve spring seat from valve spring.

4. Push valve stem to combustion chamber side, and remove valve.
 - Inspect valve guide clearance before removal. Refer to [EM-152, "VALVE GUIDE CLEARANCE"](#) .
 - Note installation point.
5. Remove valve oil seal with valve oil seal puller.
6. When valve seat must be replaced, refer to [EM-153, "VALVE SEAT REPLACEMENT"](#) .
7. When valve guide must be replaced, refer to [EM-152, "VALVE GUIDE REPLACEMENT"](#) .
8. Remove spark plug with spark plug wrench.
9. Remove spark plug tube, if necessary using pliers.

CAUTION:

- Be careful not to damage cylinder head.
- Do not remove spark plug tube if not necessary. Once removed, the spark plug tube cannot be reused because of deformation.

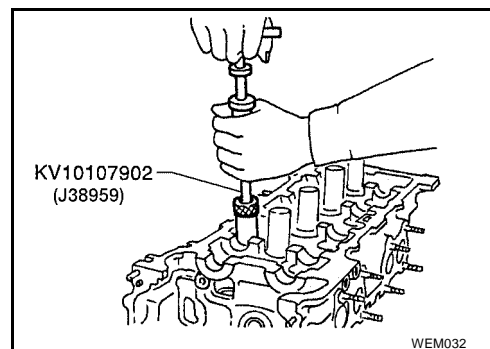
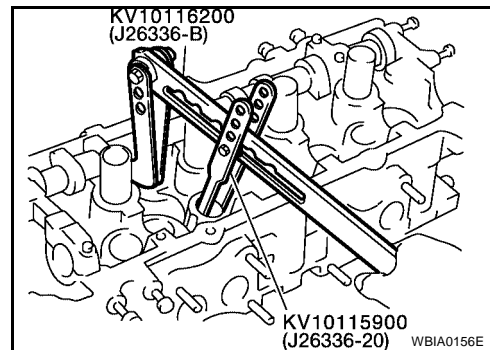

ASSEMBLY

1. Install valve guide. Refer to [EM-152, "VALVE GUIDE REPLACEMENT"](#) .
2. Install valve seat. Refer to [EM-153, "VALVE SEAT REPLACEMENT"](#) .
3. Install valve oil seal.
 - Install with valve oil seal drift to match dimension in illustration.
4. Install valve.
 - Install larger diameter to intake side.

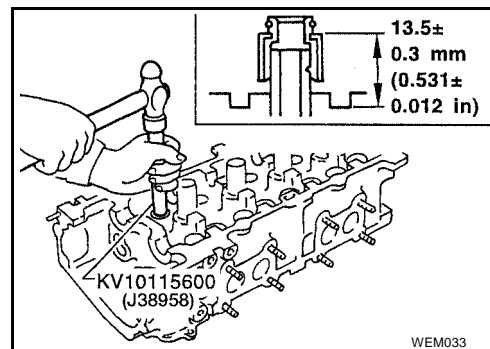

CYLINDER HEAD

[QR25DE]

5. Install valve spring.
 - Install smaller pitch (valve spring seat side) to cylinder head side.
 - Note the identification color of the valve spring:
 - Intake: blue
 - Exhaust: yellow
6. Install valve spring retainer.
7. Install valve collet.
 - Compress valve spring with valve spring compressor. Install valve collet with magnet wand.
 - Tap stem edge lightly with plastic hammer after installation to check its installed condition.
8. Install valve lifter.
9. Install spark plug tube.
 - a. Remove old liquid gasket from cylinder head side mounting hole.
 - b. Apply liquid gasket all around on spark plug tube with a 12 mm (0.47 in) width from edge of spark plug tube on the press fit side.
 - Use Genuine Anaerobic Liquid Gasket or equivalent. Refer to [GI-44, "RECOMMENDED CHEMICAL PRODUCTS AND SEALANTS"](#).
 - c. Press fit spark plug tube so that height is to "H" as shown.

Press fit height "H" standard value : 38.55 - 38.65 mm (1.518 - 1.522 in)

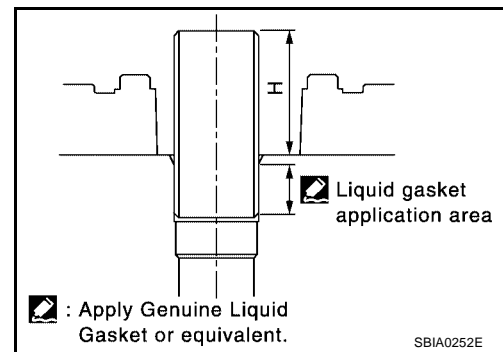
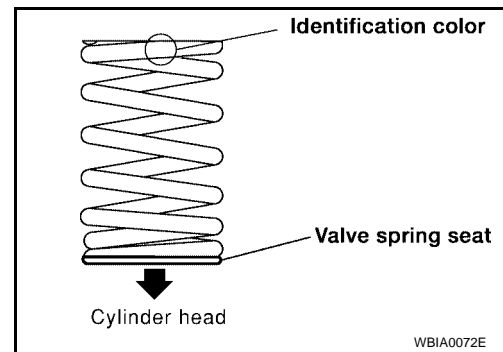

CAUTION:

- When press fitting be careful not to deform spark plug tube.
- After press fitting, wipe off any protruding liquid gasket on top surface of cylinder head.

10. Install spark plug.

Inspection After Disassembly CYLINDER HEAD DISTORTION

1. Wipe off oil and remove water scale deposits, old gasket, old sealer, and carbon with a scraper.

CAUTION:

Use care not to allow gasket debris to enter passages for oil or water.

2. At each of several locations on bottom surface of cylinder head, measure distortion in six directions.

Standard : 0.1 mm (0.004 in) or less

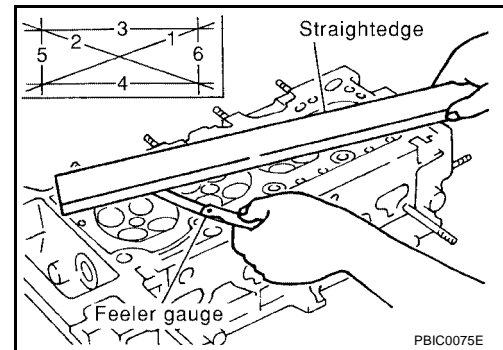

VALVE DIMENSIONS

Check dimensions of each valve. Refer to [EM-187, "VALVE"](#).

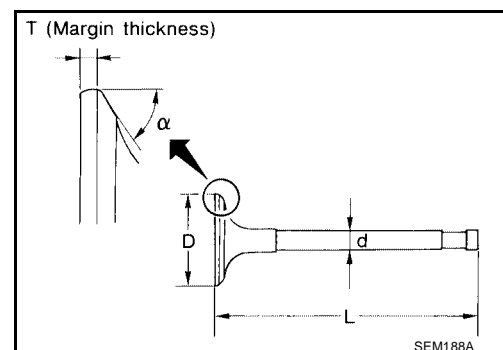

VALVE GUIDE CLEARANCE

Perform this inspection before removing the valve guide.

1. Make sure that the valve stem diameter is within the specification.
2. Push the valve out by approximately 15 mm (0.59 in) toward the combustion chamber side to measure the valve's run-out volume (in the direction of dial gauge) with dial gauge.
3. Half of the run-out volume accounts for the valve guide clearance.

Valve to guide clearance

Intake : 0.020 - 0.053 mm (0.0008 - 0.0021 in)

Exhaust : 0.030 - 0.063 mm (0.0012 - 0.0025 in)

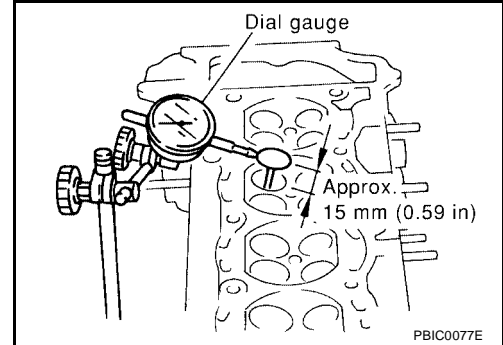

VALVE GUIDE REPLACEMENT

When valve guide is removed, replace with oversized (0.2 mm, 0.008 in) valve guide.

1. To remove valve guide, heat cylinder head to 110° to 130°C (230° to 266°F) by soaking in heated oil.

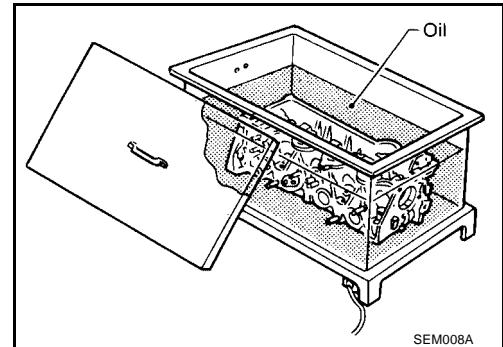

2. Drive out valve guide with a press [under a 20 kN (2.2 ton-force) pressure] or hammer and suitable tool.

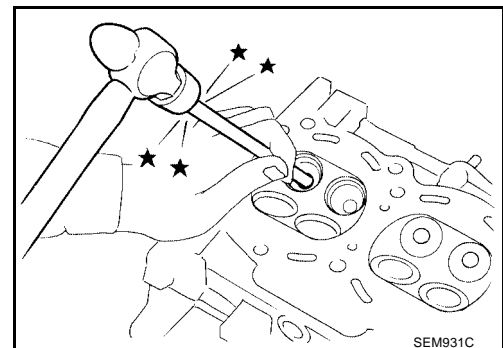

3. Ream cylinder head valve guide hole.

Valve guide hole diameter for intake and exhaust : 10.175 - 10.196 mm (0.4006 - 0.4014 in)

4. Heat cylinder head to 110° to 130°C (230° to 266°F) by soaking in heated oil.

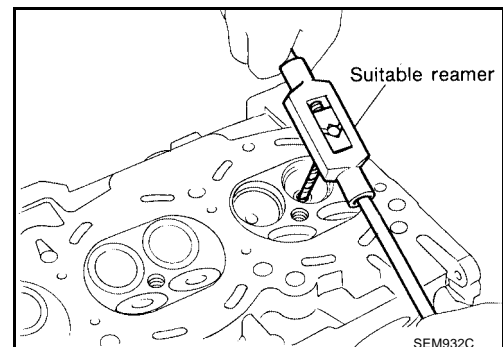

CYLINDER HEAD

[QR25DE]

5. Press valve guide from camshaft side to dimensions as in illustration.

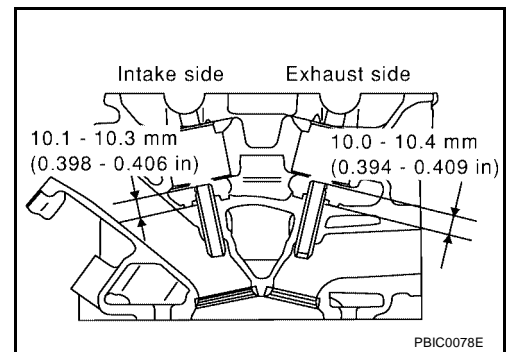

6. Using valve guide reamer, apply reamer finish to valve guide.

Intake and exhaust : 6.000 - 6.018 mm (0.2362 - 0.2369 in)

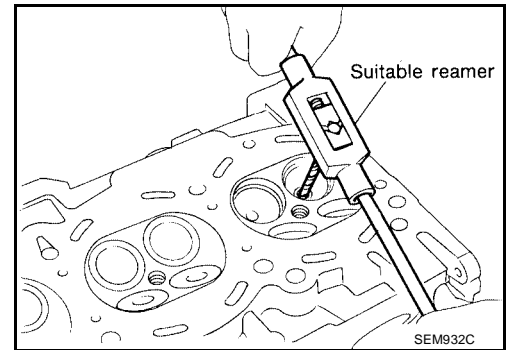

VALVE SEAT CONTACT

After confirming that the dimensions of valve guides and valves are within specifications, perform this procedure:

- Apply prussian blue (or white lead) onto contacting surface of valve seat to check the condition of the valve contact on the seat surface.
- Check if the contact area band is continuous all around the circumference.
- If not, grind to adjust valve fitting and check again. If the contacting surface still has NG conditions even after the re-check, replace the valve seat.

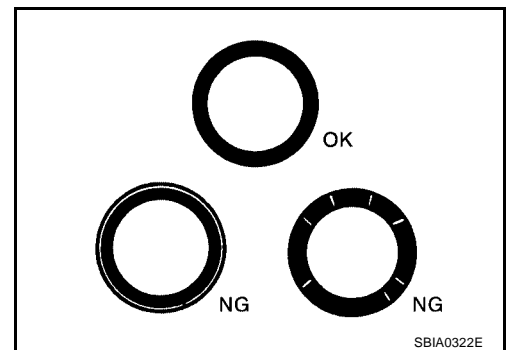

VALVE SEAT REPLACEMENT

When valve seat is removed, replace with an oversized [0.5 mm, (0.020 in)] valve seat.

1. Bore out old seat until it collapses. Boring should not continue beyond the bottom face of the seat recess in the cylinder head. Set the machine depth stop to ensure this.
2. Ream cylinder head recess diameter for service valve seat.

Intake : 37.000 - 37.016 mm (1.4567 - 1.4573 in)

Exhaust : 32.000 - 32.016 mm (1.2598 - 1.2605 in)

- Be sure to ream in circles concentric to the valve guide center. This will enable the valve seat to fit correctly.

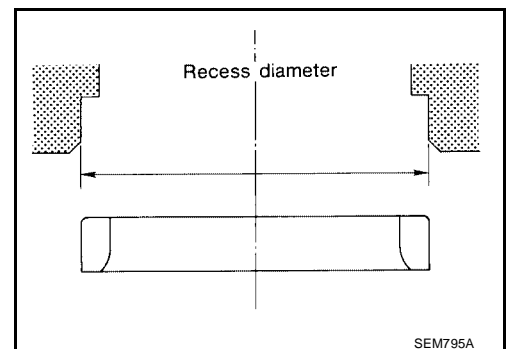

CYLINDER HEAD

[QR25DE]

- Heat cylinder head to 110° to 130°C (230° to 266°F) by soaking in heated oil.
- Provide valve seats cooled well with dry ice. Force fit valve seat into cylinder head.

CAUTION:

Avoid directly touching the cold valve seats.

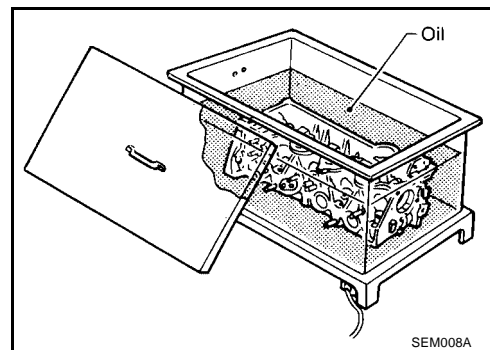

SEM008A

- Using a valve seat cutter set or a valve seat grinder, finish the seat to the specified dimensions.

CAUTION:

When using valve seat cutter, firmly grip the cutter handle with both hands. Then, press on the contacting surface all around the circumference to cut in a single drive. Improper pressure on the cutter or cutting many different times may result in a defective valve seat.

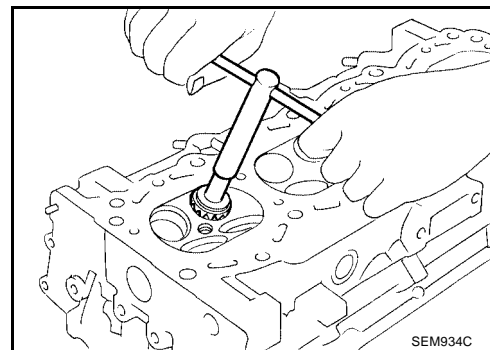

SEM934C

Grind to obtain the dimensions indicated as shown.

Standard

- D1 dia. : 33.5 mm (1.3189 in)
- D2 dia. : 35.1 - 35.3 mm (1.382 - 1.390 in)
- D3 dia. : 39.0 - 39.2 mm (1.535 - 1.543 in)
- D4 dia. : 28 mm (1.10 in)
- D5 dia. : 29.9 - 30.1 mm (1.177 - 1.185 in)
- D6 dia. : 33.5 - 33.7 mm (1.319 - 1.327 in)

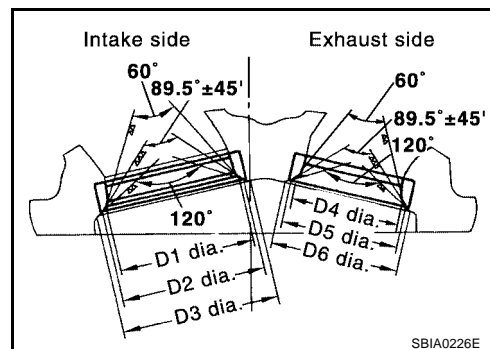

SBIA0226E

- Using compound, grind to adjust valve fitting.
- Check again for normal contact.

VALVE SPRING SQUARENESS

Set try square along the side of the valve spring and rotate the spring. Measure the maximum clearance between the top face of the spring and the try square.

Limit : 1.9 mm (0.0748 in)

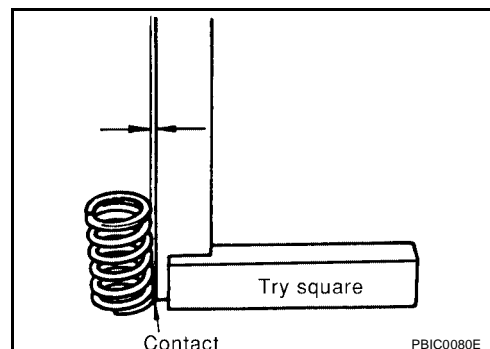

PBIC0080E

VALVE SPRING DIMENSIONS AND VALVE SPRING PRESSURE LOAD

Check valve spring pressure with valve spring seat installed at specified spring height. Replace if not within specifications.

CYLINDER HEAD

[QR25DE]

CAUTION:

Do not remove the valve spring seat.

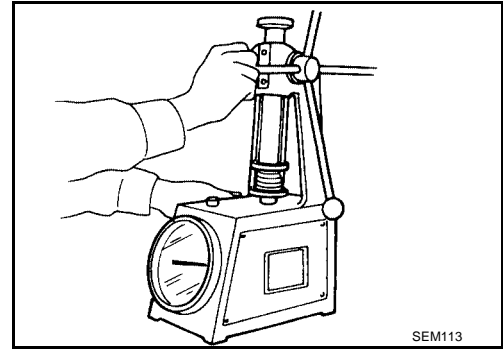

STANDARD	INTAKE (identification color: blue)	EXHAUST (identification color: yellow)
Free height	44.84 - 45.34 mm (1.7654 - 1.7850 in)	45.28 - 45.78 mm (1.7827 - 1.8024 in)
Installation height	35.30 mm (1.390 in)	35.30 mm (1.390 in)
Installation load	151 - 175 N (15.4 - 17.8 kg-force, 34 - 39 lb-force)	151 - 175 N (15.4 - 17.8 kg-force, 34 - 39 lb-force)
Height during valve open	24.94 mm (0.9819 in)	26.39 mm (1.0390 in)
Load with valve open	358 - 408 N (36.5 - 41.6 kg-force, 80 - 92 lb-force)	325 - 371 N (33.1 - 37.8 kg-force, 73 - 83 lb-force)

A
EM
C
D
E
F
G
H
I
J
K
L
M

ENGINE ASSEMBLY

Removal and Installation

SEC. 112

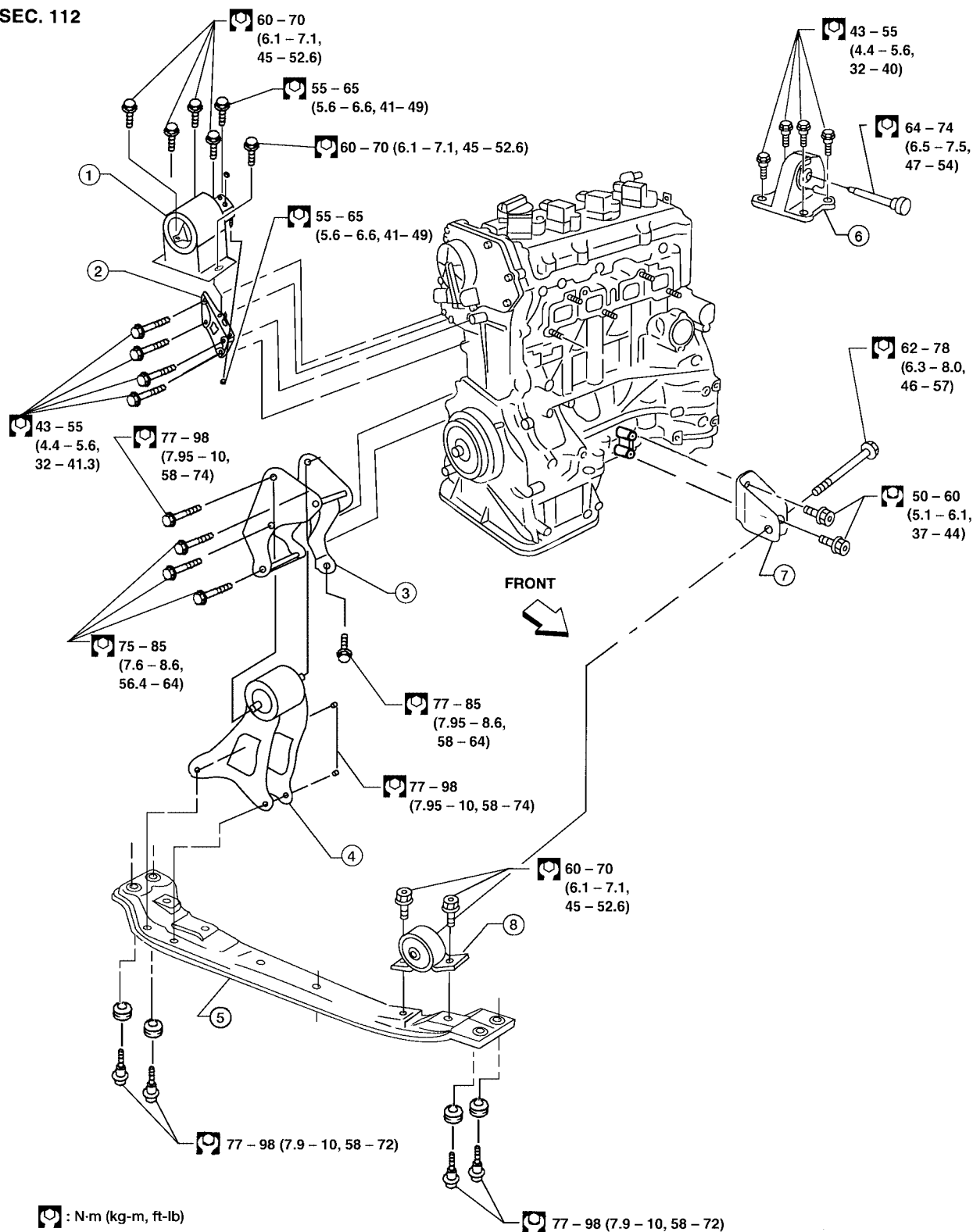

WBIA0205E

- | | | |
|-----------------------|----------------------------------|---------------------------------|
| 1. RH engine mount | 2. RH engine mounting bracket | 3. Rear engine mounting bracket |
| 4. Rear engine mount | 5. Center member | 6. LH engine mount |
| 7. Front engine mount | 8. Front engine mounting bracket | |

WARNING:

- Place chocks at the front and back of the rear wheels. A
- For engines not equipped with slingers, attach proper slingers and bolts as described in the Parts Catalog. EM

CAUTION:

- Do not start working until the exhaust system and coolant are cool. C
- If items or work required are not covered by the engine main body section, refer to the applicable sections. D
- Use the correct supporting points for lifting and jacking. Refer to [GI-39, "Lifting Points and Tow Truck Towing"](#) . E
- In removing the drive shaft, be careful not to damage the grease seals on the transaxle.
- Before separating the engine and transaxle, remove the crankshaft position sensor (POS) from the assembly.
- Be sure not to damage the edge of the crankshaft position sensor (POS) or the ring gear teeth.

REMOVAL

1. Release fuel pressure. Refer to [EC-1257, "FUEL PRESSURE RELEASE"](#) . F
2. Disconnect the fuel rail at the fuel hose quick connector (engine side). Refer to [EM-105, "INTAKE MANIFOLD"](#) . G
3. Drain the engine oil. Refer to [LU-17, "Changing Engine Oil"](#) .
4. Drain the engine coolant. Refer to [MA-23, "DRAINING ENGINE COOLANT"](#) .
5. Remove the engine hood assembly. Refer to [EI-13, "Removal and Installation"](#) .
6. Remove the battery, battery hold downs, and battery tray. Refer to [SC-4, "BATTERY"](#) . H
7. Disconnect the MAF sensor electrical connector.
8. Remove the air duct and air cleaner case assembly. Refer to [EM-103, "Removal and Installation"](#) . I
9. Disconnect the heater hoses.
10. Remove the radiator and radiator fan assembly. Refer to [CO-30, "Removal and Installation"](#) . J
11. Remove the alternator. Refer to [SC-32, "Removal"](#) .
12. Remove the left and right drive shafts. Refer to [FAX-14, "Removal"](#) .
13. Remove the engine undercovers.
14. Dismount the A/C compressor with piping connected and secure with wire to the radiator support.
15. Disconnect the transaxle shift control cables, if equipped (A/T only).
16. Disconnect the brake power booster vacuum hose.
17. Disconnect the following engine compartment electrical harness connectors: L
 - Heated oxygen sensors
 - Starter assembly
 - Coolant temperature sensor
 - Camshaft position sensor (PHASE)
 - EVAP canister purge volume control solenoid
 - Backup lamp switch
 - Vehicle speed sensor
 - Electric throttle control actuator
 - Ignition coils
 - Fuel injector harness
 - Engine ground straps
 - Intake valve timing control solenoid
 - Transaxle sensors (A/T only)
 - Crankshaft position sensor (POS)
 - Knock sensor
 - Oil pressure switch
 - Swirl control valve

- Power steering pressure switch
18. Remove clutch operating cylinder from transaxle, and move it aside (M/T models).
 19. Remove engine coolant reservoir tank.
 20. Remove front exhaust tube. Refer to [EX-3, "Removal and Installation"](#) .
 21. Dismount the power steering pump with piping connected and position it aside with wire.
 22. Install engine slingers into front left cylinder head and rear right cylinder head.

- Use alternator bracket mounting bolt holes for the front slinger.
- Use the proper slingers and bolts as described in the Parts Catalog.

Slinger bolts - front : 51.0 - 64.7 N·m (5.2 - 6.5 kg·m, 38 - 47 ft·lb)

Slinger bolts - rear : 24.5 - 31.4 N·m (2.5 - 3.2 kg·m, 18 - 23 ft·lb)

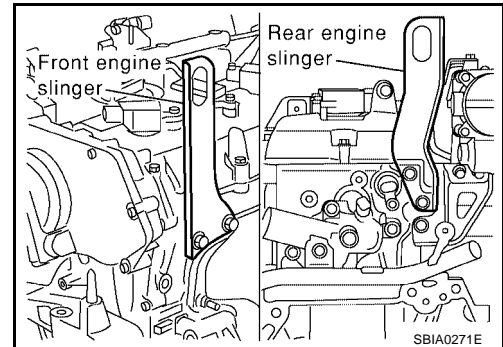

23. Support the engine/transaxle assembly with engine lifting equipment from the top and a suitable transmission jack under the engine/transaxle assembly, with the vehicle raised on a hoist.

24. Remove the center member.
 - Remove front and rear engine mounting insulator through-bolt and the center member bolts.

25. Remove RH engine mounting insulator.
26. Remove LH transaxle mounting insulator through-bolts.
27. Lower the engine/transaxle assembly from the engine compartment on the platform jack, steady it safely with the lifting equipment.
28. Remove the starter motor. Refer to [SC-21, "Removal"](#) .
29. Separate the engine and transaxle.

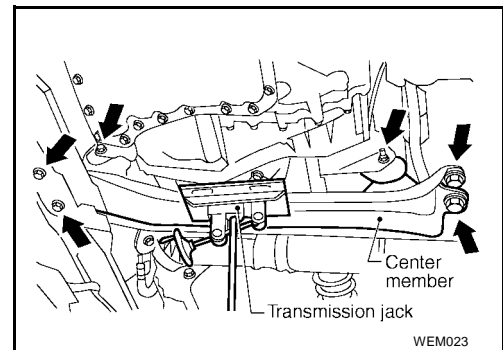

INSTALLATION

Installation is in the reverse order of removal.

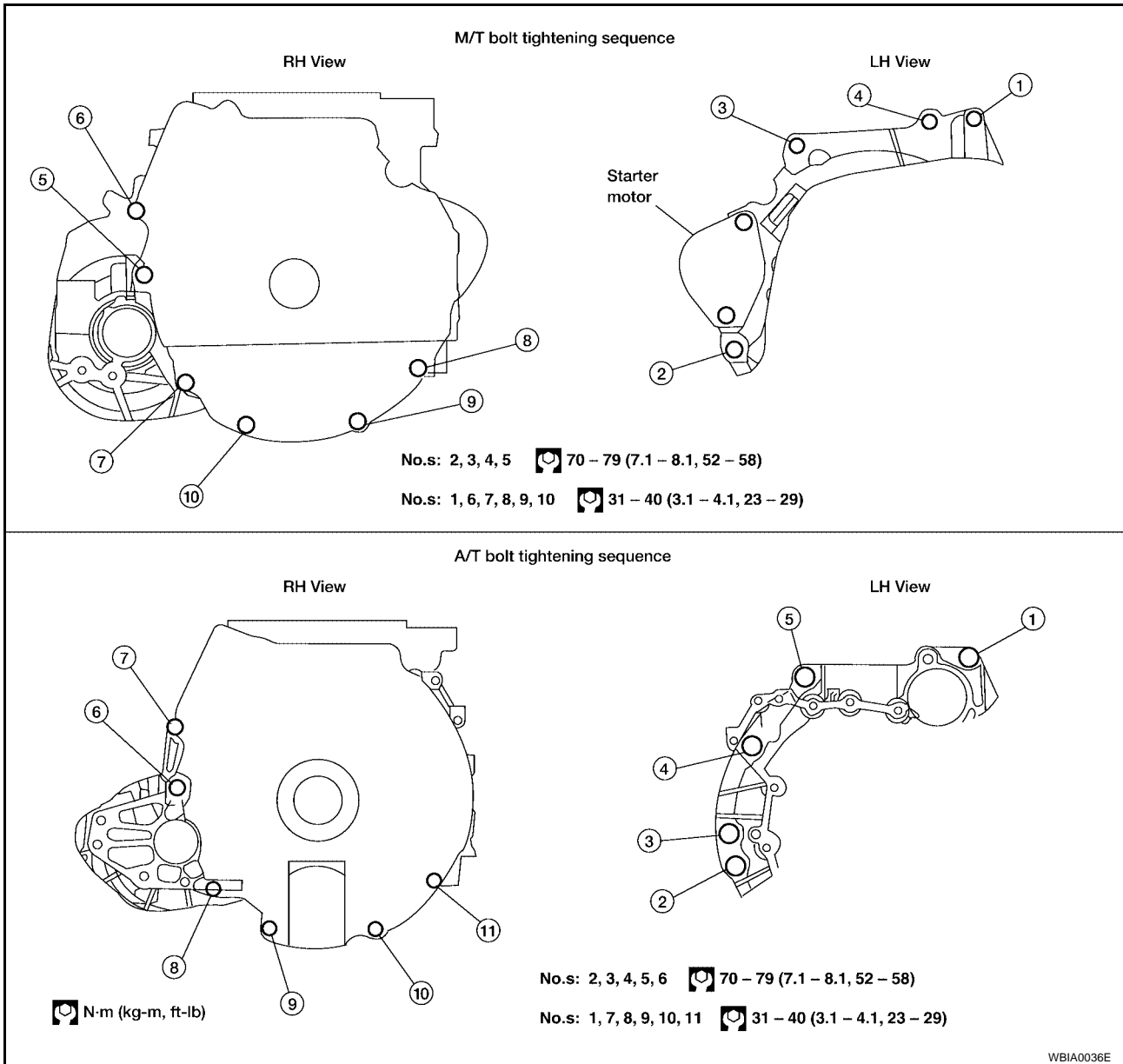

- Do not allow oil to get on mounting insulators. Be careful not to damage mounting insulators.
- If parts have a direction mark (arrow) this indicates front of the vehicle, and the parts must be installed according to the identification mark.

INSPECTION AFTER INSTALLATION

- Before starting engine, check the levels of engine coolant, lubricants, engine oil. If less than required quantity, fill to the specified level.
- Run engine to check for unusual noise and vibration.
- Warm up engine thoroughly to make sure there is no leakage of coolant, lubricants, oil, fuel, and exhaust gas.
- Bleed air from passages in pipes and tubes of applicable lines.

CYLINDER BLOCK

Disassembly and Assembly

SEC.110 • 120 • 221 • 226

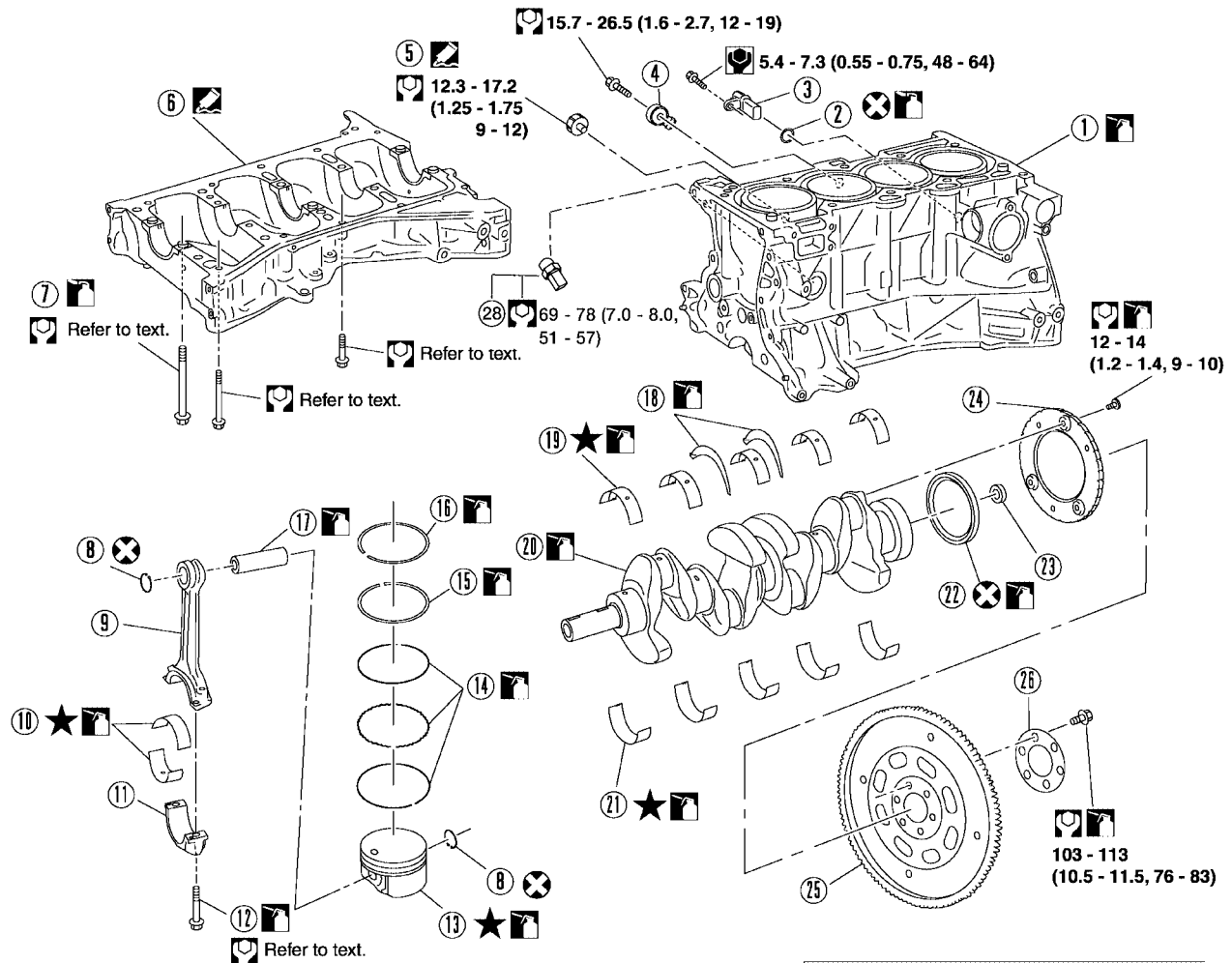

- ★ : Select with proper clearance.
- ☑ : Apply engine oil.
- ☑ : Apply Genuine RTV Silicone Sealant or equivalent.
Refer to GI Section.
- ⊗ : N·m (kg·m, ft·lb)
- ⊙ : N·m (kg·m, in·lb)

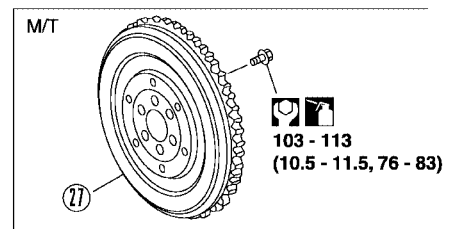

- | | | |
|---|--------------------------------|-------------------------------------|
| 1. Cylinder block | 2. O-ring | 3. Crankshaft position sensor (POS) |
| 4. Knock sensor | 5. Oil pressure switch | 6. Lower cylinder block |
| 7. Lower cylinder block bolt | 8. Snap ring | 9. Connecting rod |
| 10. Connecting rod bearing | 11. Connecting rod bearing cap | 12. Connecting rod bearing cap bolt |
| 13. Piston | 14. Oil ring | 15. Second ring |
| 16. Top ring | 17. Piston pin | 18. Main thrust bearing |
| 19. Main bearing upper | 20. Crankshaft | 21. Main bearing lower |
| 22. Crankshaft rear oil seal | 23. Pilot converter (A/T only) | 24. Crankshaft signal plate |
| 25. Drive plate | 26. Reinforcement plate | 27. Flywheel |
| 28. Cylinder block heater (if equipped) | | |

WBIA0073E

CAUTION:

Apply new engine oil to parts marked in illustration before installation.

DISASSEMBLY

1. Remove the engine and transaxle as an assembly from the vehicle, and separate the transaxle from the engine. Refer to [EM-156, "Removal and Installation"](#).
2. Mount the engine on a suitable engine stand.
3. Drain any remaining engine oil and coolant from the engine.
4. Remove the following components and associated parts.
 - Exhaust manifold and three way catalyst assembly. Refer to [EM-110, "Removal and Installation"](#).
 - Intake manifold collector. Refer to [EM-105, "Removal and Installation"](#).
 - Intake manifold and fuel tube assembly. Refer to [EM-105, "Removal and Installation"](#).
 - Ignition coils. Refer to [EM-115, "Removal and Installation"](#).
 - Rocker cover. Refer to [EM-121, "Removal and Installation"](#).
 - Front cover, timing chain, and balancer unit. Refer to [EM-134, "Removal and Installation"](#).
 - Cylinder head. Refer to [EM-147, "Removal and Installation"](#).
5. Remove the cylinder block heater, if equipped.
6. Remove the knock sensor.

CAUTION:

Carefully handle the sensor and do not drop the sensor.

7. Remove crankshaft position sensor (POS).

CAUTION:

- Avoid impacts such as a dropping.
- Do not disassemble.
- Keep it away from metal particles.
- Do not place sensor close to magnetic materials.

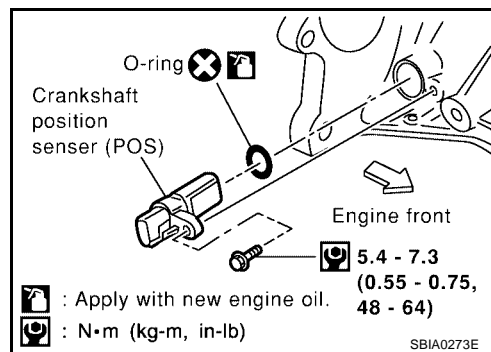

8. Remove the flywheel (M/T models) or drive plate (A/T models). Hold the crankshaft with a stopper plate and remove the mounting bolts using Tool.

Tool numbers

For Flywheel bolt : J-45737

For Drive plate bolt : J-45816

CAUTION:

- Be careful not to damage the flywheel contact surface for the clutch disc.

NOTE:

- The flywheel two-block construction allows movement in response to transmission side pressure, or when twisted in its rotational direction, therefore, some amount of noise is normal.

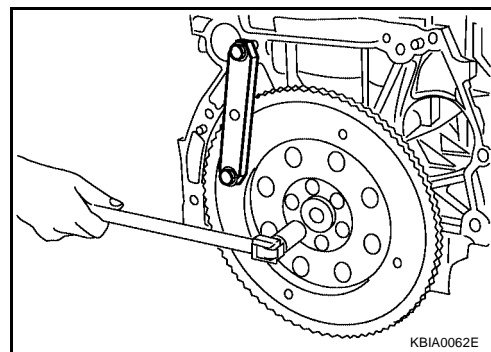

CYLINDER BLOCK

[QR25DE]

9. Remove pilot converter using Tool (A/T models).

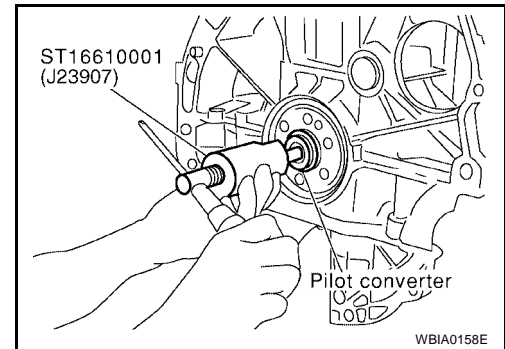

10. Remove the piston and connecting rod assemblies.
- Position the crankshaft and corresponding connecting rod, to be removed, to the bottom dead center stroke.
 - Remove the connecting rod cap. Number the cap so it can be assembled in the same position.
 - Using a hammer handle or similar tool, push the piston and connecting rod assembly out of the top of the cylinder block. Number the piston and rod so it can be assembled in the same position.
 - Before removing the piston and connecting rod assembly, check the connecting rod side clearance. Refer to [EM-176, "CONNECTING ROD SIDE CLEARANCE"](#).

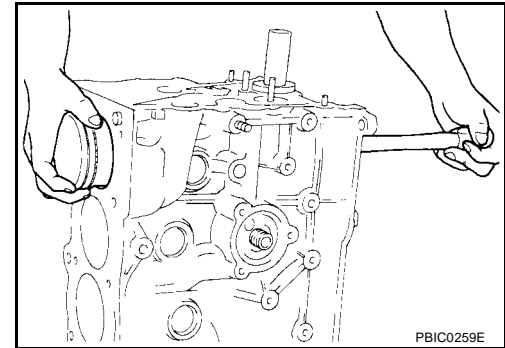

11. Remove the connecting rod bearings. If reusing, number them so they can be assembled in the same position and direction.

CAUTION:

- When removing them, note the installation position. Keep them in the correct order.

12. Remove the piston rings from the piston.

- Use a piston ring expander.

CAUTION:

- When removing the piston rings, be careful not to damage the piston.
- Be careful not to damage piston rings by expanding them excessively, if reusing them.
- Before removing the piston rings, check the piston ring side clearance. Refer to [EM-177, "PISTON RING SIDE CLEARANCE"](#).

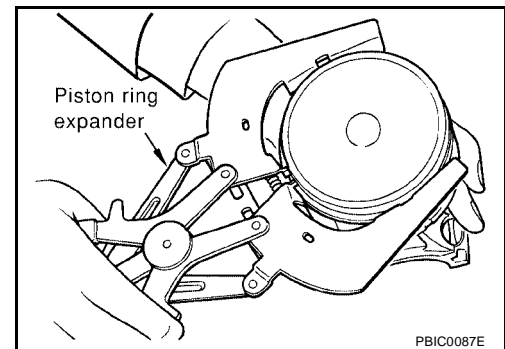

13. Remove the piston from the connecting rod as follows.

- Using a snap ring pliers, remove the two snap rings.

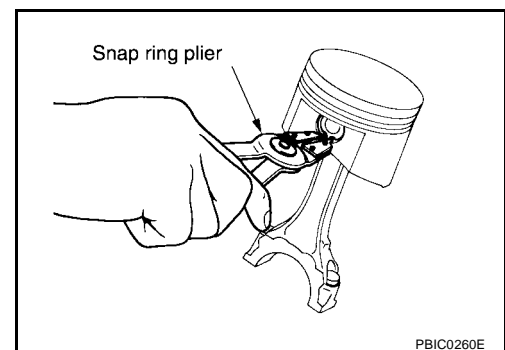

CYLINDER BLOCK

[QR25DE]

- b. Heat the piston to 60° - 70°C (140° - 158°F) with a heat gun, or equivalent.

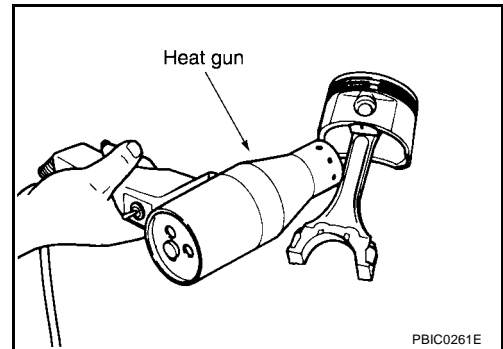

- c. Push out piston pin with a punch of an outer diameter of approximately 19 mm (0.75 in).

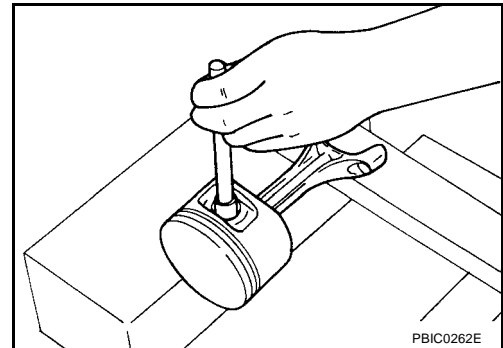

14. Remove the lower cylinder block mounting bolts.

- Before loosening the lower cylinder block mounting bolts, measure the crankshaft side clearance. Refer to [EM-175](#), "[CRANKSHAFT SIDE CLEARANCE](#)".
- Loosen them in the order shown to remove them.

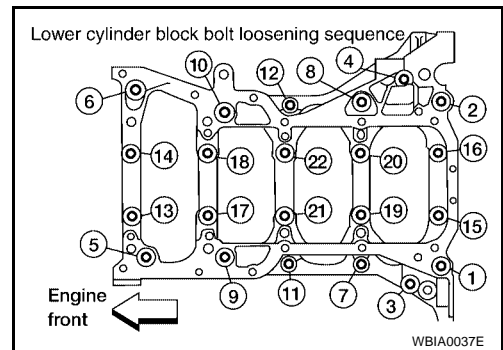

15. Remove the lower cylinder block.

- Using Tool (seal cutter) cut the Silicone RTV Sealant and remove the lower cylinder block from the cylinder block.

CAUTION:
Be careful not to damage the mounting surface.

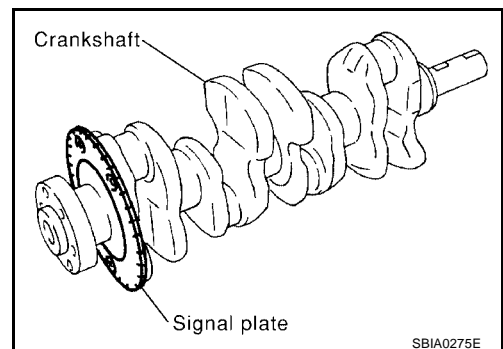

16. Remove the crankshaft.

- CAUTION:**
- Do not damage or deform the signal plate while mounted on the crankshaft.
 - When setting the crankshaft on a flat surface, use a block of wood to avoid interference between the signal plate and the surface.
 - Do not remove signal plate unless it is necessary.

17. Pull the rear oil seal out of the rear end of the crankshaft.

CAUTION:
Do not to damage the crankshaft or cylinder block when removing the rear oil seal.

A
EM
C
D
E
F
G
H
I
J
K
L
M

NOTE:

When replacing the rear oil seal without removing the cylinder block, use a screwdriver to pull it out from between crankshaft and block.

- Remove the main bearings and thrust bearings from the cylinder block and lower cylinder block.

CAUTION:

Identify and number the bearings, if reusing them, so that they are assembled in the same position and direction.

ASSEMBLY

- Using compressed air, clean out the coolant and oil passages in the cylinder block, the cylinder bore and the crankcase to remove any foreign material.

CAUTION:

Use approved safety glasses to protect your eyes.

- Install the drain plugs on the cylinder block.

- Apply Silicone RTV Sealant.
Use Genuine Silicone RTV Sealant, or equivalent. Refer to GI-44, "RECOMMENDED CHEMICAL PRODUCTS AND SEALANTS".
- Replace the copper washers with new ones.

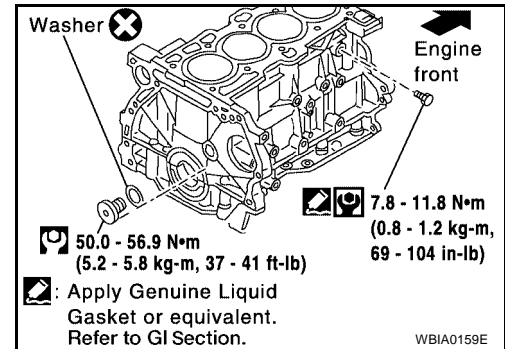

- Install the main bearings and the thrust bearings.
 - Remove dust, dirt, and oil from the bearing mating surfaces of the cylinder block and lower cylinder block.
 - Install the thrust bearings to both sides of the No. 3 main bearing journal on the cylinder block.
 - Install the thrust bearings with the oil groove facing the crankshaft arm (outside).

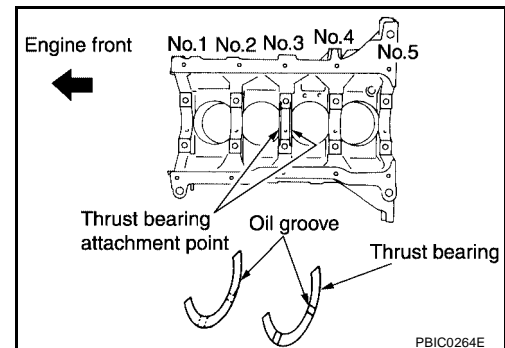

- Install the main bearings paying attention to their position and direction.
 - The main bearing with an oil hole and groove goes on the cylinder block. The one without them goes on the lower cylinder block.
 - Only the main bearing (on the cylinder block) for No. 3 journal has different specifications.
 - Before installing the bearings, apply engine oil to the bearing friction surface (inside). Do not apply oil to the back surface, but thoroughly clean it.
 - When installing, align the bearing stopper to the notch.
 - Make sure that the oil holes on the cylinder block and those on the corresponding bearing are aligned.

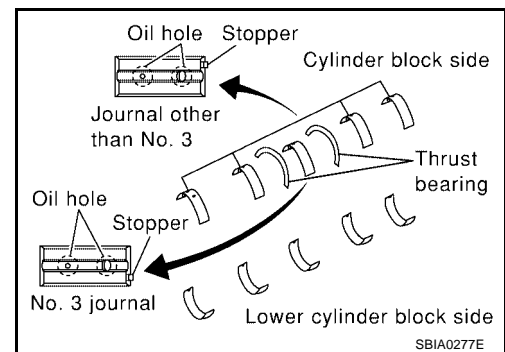

CYLINDER BLOCK

[QR25DE]

4. Install the signal plate to the crankshaft.

Signal plate bolts : 12 - 14 N·m (1.22 - 1.43 kg·m,
9 - 10 ft·lb)

- a. Position the crankshaft and signal plate using a positioning dowel pin, and tighten the mounting bolts to specification.
b. Remove the dowel pin.

CAUTION:

Be sure to remove dowel pin before installing the crankshaft.

NOTE:

Dowel pins for the crankshaft and signal plate are supplied as a set for each.

5. Install the crankshaft onto the cylinder block.
● While turning the crankshaft by hand, check that it turns smoothly.
6. Install the lower cylinder block.

- Apply Silicone RTV Sealant to positions shown in the figure.

NOTE:

Cylinder block and lower cylinder block are machined together. Neither of them can be replaced separately.

CAUTION:

After the Silicone RTV Sealant is applied, the lower cylinder block installation must be finished within 5 minutes.

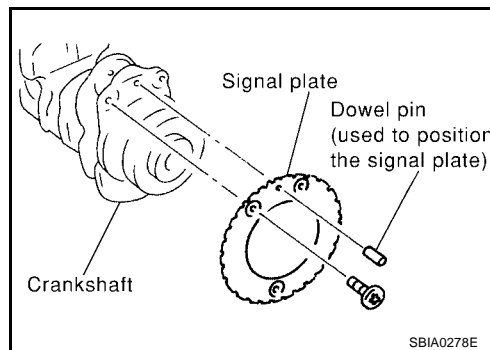

7. Tighten lower cylinder block mounting bolts in the numerical order shown and according to the following steps:

NOTE:

Apply new engine oil to threads and seat surfaces of the mounting bolts.

Lower cylinder block mounting bolts

Step 1 (bolts 11 - 22) : 22.6 - 27.5 N·m (2.3 - 2.8 kg·m,
17 - 20 ft·lb)

Step 2 (bolts 1 - 10) : 36.3 - 42.2 N·m (3.7 - 4.3 kg·m,
27 - 31 ft·lb)

Step 3 (bolts 1 - 10) : 60° - 65° (target: 60°)

CAUTION:

Use an angle wrench (special service tool) or protractor to check tightening angle. Do not tighten by visual inspection.

- Wipe off completely any protruding Silicone RTV Sealant on the exterior of engine.
- Check crankshaft side clearance. Refer to [EM-175. "CRANK-SHAFT SIDE CLEARANCE"](#).
- After installing the mounting bolts, make sure that the crankshaft can be rotated smoothly by hand.

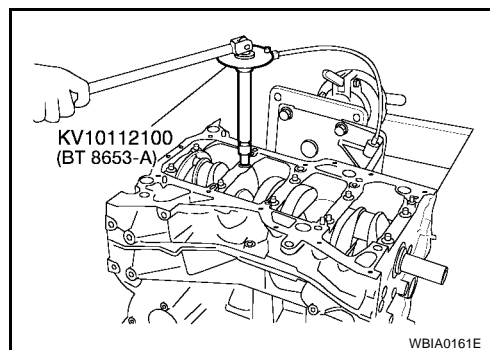
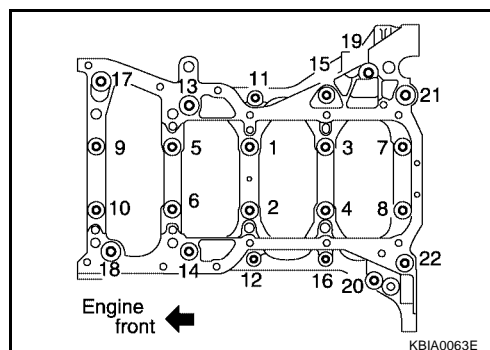
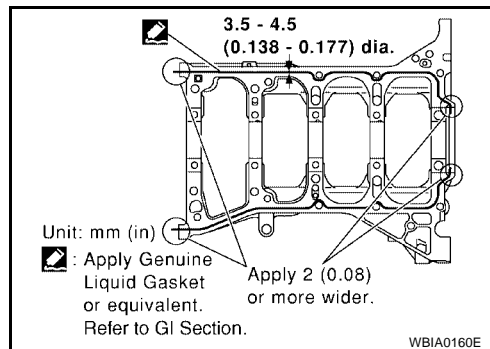

8. Install the rear oil seal.

CYLINDER BLOCK

[QR25DE]

- Press in rear oil seal to the position shown in the figure.

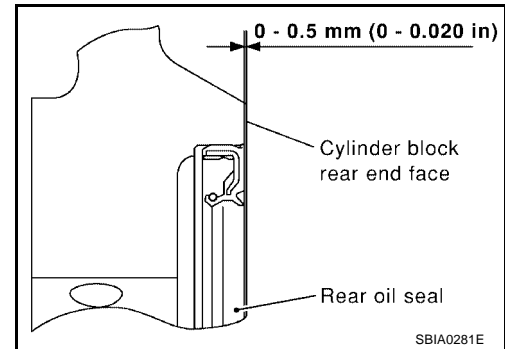

- Press the oil seal between cylinder block and crankshaft with a suitable drift.
- Be careful not to touch the grease on the oil seal lip.
- Be careful not to cause scratches or burrs when pressing in the rear oil seal.

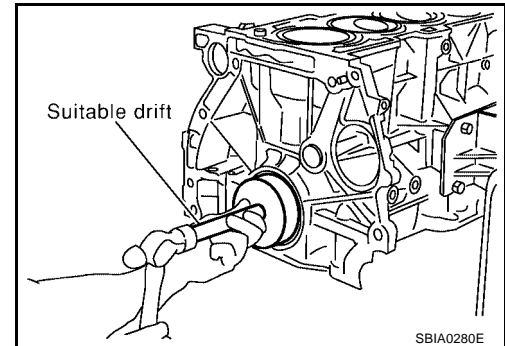

9. Install the piston to the connecting rod. Assemble the components in their original positions.
- a. Using a snap ring pliers, install the snap ring into the grooves of the piston's rear side.
- Insert the piston pin snap ring fully into groove.
- b. Install the piston to the connecting rod.
- Using a heat gun, heat the piston [approximately 60° - 70° C (140° - 158° F)] until the piston pin can be pushed in by hand without excessive force. From the front to the rear, insert the piston pin into the piston and the connecting rod.
 - Assemble so that the front mark on the piston crown and the oil holes and the cylinder No. on the connecting rod are positioned as shown in the figure.
- c. Install the piston pin snap ring into the front of the piston.
- Check that the connecting rod moves smoothly.

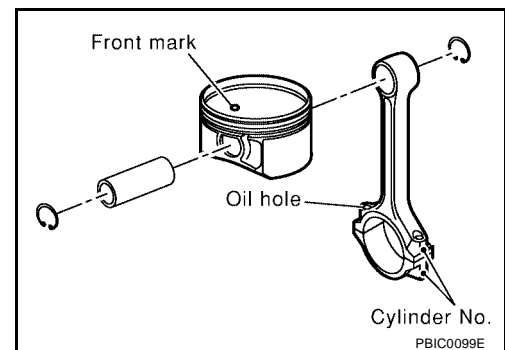

10. Using a piston ring expander, install the piston rings. Assemble the components in their original positions.

CAUTION:

Be careful not to damage the piston.

- Position each ring with the gap as shown in the figure, referencing the piston front mark as the starting point.
- Install the top ring and the second ring with the stamped surface facing upward.

Stamped mark

: A (top ring)

: 2A (second ring)

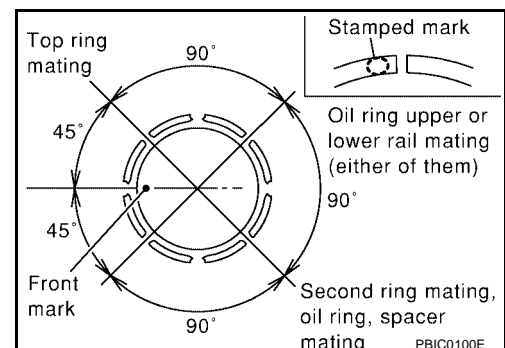

CYLINDER BLOCK

[QR25DE]

11. Install the connecting rod bearings to the connecting rod and the connecting rod cap. Assemble the components in their original positions.

- When installing the connecting rod bearings, apply engine oil to the bearing friction surface (inside). Do not apply oil to the back surface, but thoroughly clean the back.
- When installing, align the connecting rod bearing stopper protrusion with the notch of the connecting rod to install.
- Check the oil holes on the connecting rod and those on the corresponding bearing are aligned.

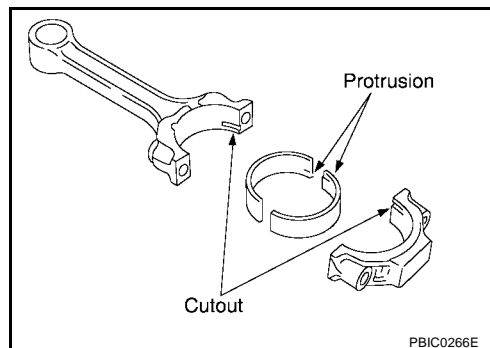

12. Install the piston and connecting rod assembly to the crankshaft. Assemble the components in their original positions.

- Rotate the crankshaft so the pin corresponding to the connecting rod to be installed is at the bottom dead center position.
- Apply engine oil sufficiently to the cylinder bore, piston, and crankshaft pin.
- Match the cylinder position number with the cylinder No. on the connecting rod for installation.
- Using a piston ring compressor, install the piston with the front mark on the piston crown facing the front of the engine.

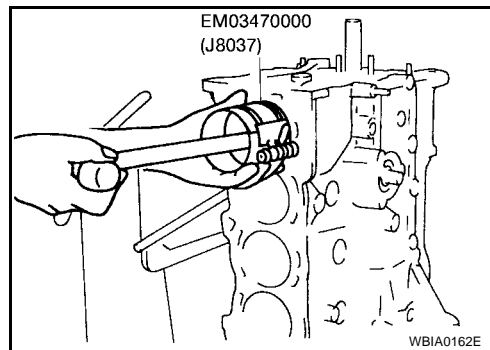

CAUTION:

Be careful not to damage the crankshaft pin, resulting from an interference of the connecting rod big end.

13. Install the connecting rod caps. Assemble the components in their original positions.

- Match the stamped cylinder number marks on the connecting rod with those on the cap to install.

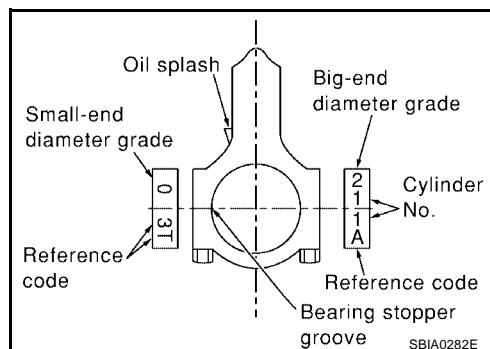

14. Tighten the connecting rod bolt as follows:
Apply engine oil to the threads and seats of the connecting rod bolts.

CAUTION:

Always use either an angle wrench or protractor. Avoid tightening based on visual check alone.

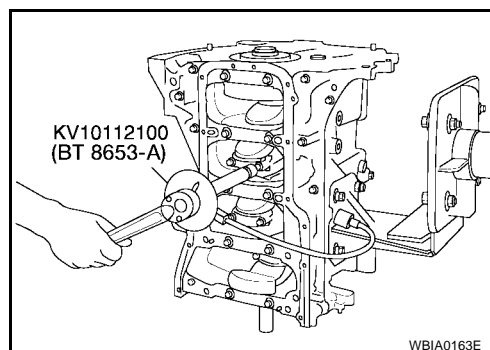

Step 1 : 18.6 - 20.6 N·m (1.9 - 2.1 kg·m, 14 - 15 ft·lb)

Step 2 : 85° - 95° (target 90° degrees)

- Check the connecting rod side clearance. Refer to [EM-176, "CONNECTING ROD SIDE CLEARANCE"](#)
- After tightening the bolts, make sure that the crankshaft rotates smoothly.

CYLINDER BLOCK

[QR25DE]

15. Install flywheel (M/T Models), or drive plate (A/T Models).

- Install drive plate, reinforcement plate and pilot converter as shown in figure.
- Using a drift with 33 mm (1.30 in) diameter, push pilot converter into the end of the crankshaft.

16. Install the cylinder block heater.

Cylinder block heater : 69 - 78 N·m (7.0 - 8.0 kg·m, 51 - 57 ft·lb)

17. Install the knock sensor.

- Make sure that there is no foreign material on the cylinder block mating surface and the back surface of the knock sensor.
- Install the knock sensor with the connector facing lower left by 45° as shown.
- Do not tighten the mounting bolts while holding the connector.
- Make sure that the knock sensor does not interfere with other parts.

Knock sensor bolt : 15.7 - 26.5 N·m (1.6 - 2.7 kg·m, 12 - 19 ft·lb)

CAUTION:

If the knock sensor is dropped, replace it with new one.

18. Install the crankshaft position sensor (POS).

Crankshaft position sensor bolt : 5.4 - 7.3 N·m (0.55 - 0.75 kg·m, 48 - 65 in·lb)

19. Installation of remaining components is in the reverse order of removal.

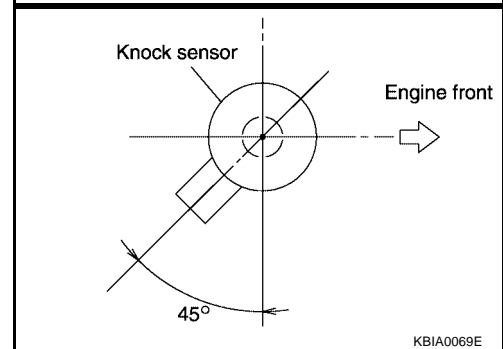
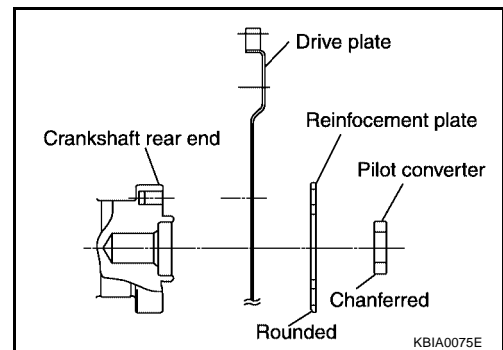

How to Select Piston and Bearing DESCRIPTION

EBS00CG8

Selection points	Selection parts	Selection items	Selection methods
Between cylinder block to crankshaft	Main bearing	Main bearing grade (bearing thickness)	Determined by match of cylinder block bearing housing grade (inner diameter of housing) and crankshaft journal grade (outer diameter of journal)
Between crankshaft to connecting rod	Connecting rod bearing	Connecting rod bearing grade (bearing thickness)	Combining service grades for connecting rod big end inner diameter and crankshaft pin outer diameter determine connecting rod bearing selection
Between cylinder block to piston	Piston and piston pin assembly (The piston is available together with piston pin as an assembly)	Piston grade (piston outer diameter)	Piston grade = cylinder bore grade (inner diameter of bore)
*Between piston to connecting rod	—	—	—

*For the service parts, the grade for fitting cannot be selected between a piston pin and a connecting rod. (Only 0 grade is available.) The information at the shipment from the plant is described as a reference.

- The identification grade stamped on each part is the grade for the dimension measured in new condition. This grade cannot apply to reused parts.

CYLINDER BLOCK

[QR25DE]

- For reused or repaired parts, measure the dimension accurately. Determine the grade by comparing the measurement with the values of each selection table.
- For details of the measurement method of each part, the reuse standards, and the selection method of the selective fitting parts, refer to the text.

HOW TO SELECT A PISTON

When New Cylinder Block is Used:

- Check the cylinder bore grade on rear left side of cylinder block, and select a piston of the same grade.
- If there is a corrected stamp mark on the cylinder block, use it as a correct reference.

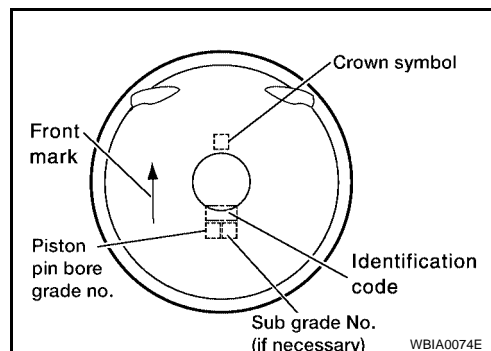
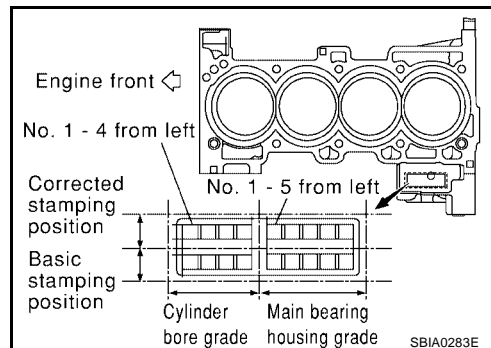

When a Cylinder Block is Reused:

1. Measure the cylinder block bore inner diameter.
2. Determine the bore grade by comparing the measurement with the values under the cylinder bore inner diameter of the "Piston Selection Table". Select the piston of the same grade.

Piston Selection Table

Unit: mm (in)

Grade number (Mark)	1	2 (or no mark)	3
Inner diameter of cylinder bore	89.000-89.010 (3.5039-3.5043)	89.010-89.020 (3.5043-3.5047)	89.020-89.030 (3.5047-3.5051)
Outer diameter of piston	88.980-88.990 (3.5031-3.5035)	88.990-89.000 (3.5035-3.5039)	89.000-89.010 (3.5039-3.5043)

NOTE:

- The piston is available together with piston pin as an assembly.
- The piston pin (piston pin bore) grade is provided only for the parts installed at the plant. For service parts, no grades can be selected. Only 0 grade is available.

HOW TO SELECT A CONNECTING ROD BEARING

When New Connecting Rod and Crankshaft are Used:

1. Apply big end inside diameter grade stamped on connecting rod side face to the row in the "Connecting Rod Bearing Selection Table".

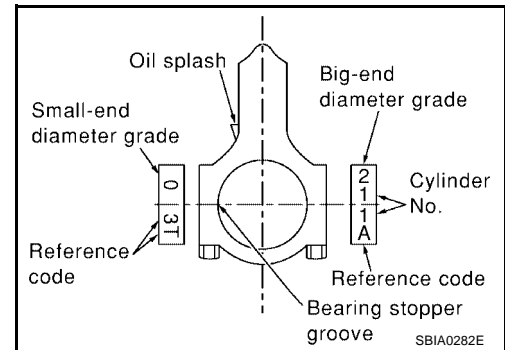

2. Apply pin diameter grade stamped on crankshaft front side to the column in the "Connecting Rod Bearing Selection Table".
3. Read the symbol at the cross point of selected row and column in the "Connecting Rod Bearing Selection Table".
4. Apply the symbol obtained to connecting rod bearing grade table to select.

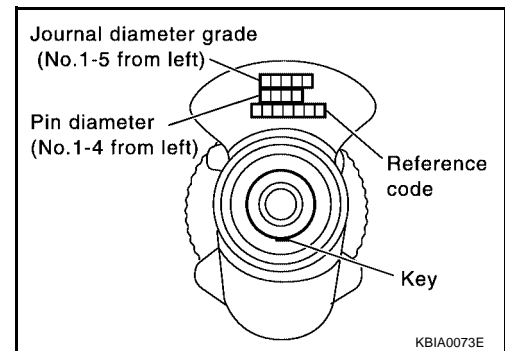

When Crankshaft and Connecting Rod are Reused:

1. Measure dimensions of the big end inner diameter of connecting rod and outer diameter of crankshaft pin individually.
2. Apply the dimension measured to the "Connecting Rod Bearing Selection Table" below.

CYLINDER BLOCK

[QR25DE]

Connecting Rod Bearing Selection Table

Mark	Outer diameter Unit: mm (in)	Connecting rod big end. inner diameter	Crankshaft pin outer diameter	Mark													
				0	1	2	3	4	5	6	7	8	9	A	B	C	
					48.000 - 48.001 (1.8898 - 1.8898)	48.001 - 48.002 (1.8898 - 1.8898)	48.002 - 48.003 (1.8898 - 1.8899)	48.003 - 48.004 (1.8899 - 1.8899)	48.004 - 48.005 (1.8899 - 1.8900)	48.005 - 48.006 (1.8900 - 1.8900)	48.006 - 48.007 (1.8900 - 1.8900)	48.007 - 48.008 (1.8900 - 1.8901)	48.008 - 48.009 (1.8901 - 1.8901)	48.009 - 48.010 (1.8901 - 1.8902)	48.010 - 48.011 (1.8902 - 1.8902)	48.011 - 48.012 (1.8902 - 1.8902)	48.012 - 48.013 (1.8902 - 1.8903)
A	44.974 - 44.973 (1.7706 - 1.7706)	0	0	0	0	0	0	0	0	0	0	0	1	1	1	1	1
B	44.973 - 44.972 (1.7706 - 1.7705)	0	0	0	0	0	0	0	0	0	0	1	1	1	1	1	1
C	44.972 - 44.971 (1.7705 - 1.7705)	0	0	0	0	0	0	0	0	1	1	1	1	1	1	1	1
D	44.971 - 44.970 (1.7705 - 1.7705)	0	0	0	0	0	0	0	1	1	1	1	1	1	1	1	1
E	44.970 - 44.969 (1.7705 - 1.7704)	0	0	0	0	0	1	1	1	1	1	1	1	1	1	1	2
F	44.969 - 44.968 (1.7704 - 1.7704)	0	0	0	1	1	1	1	1	1	1	1	1	1	1	2	2
G	44.968 - 44.967 (1.7704 - 1.7704)	0	0	1	1	1	1	1	1	1	1	1	1	2	2	2	2
H	44.967 - 44.966 (1.7704 - 1.7703)	0	1	1	1	1	1	1	1	1	1	1	2	2	2	2	2
J	44.966 - 44.965 (1.7703 - 1.7703)	1	1	1	1	1	1	1	1	1	1	2	2	2	2	2	2
K	44.965 - 44.964 (1.7703 - 1.7702)	1	1	1	1	1	1	1	1	2	2	2	2	2	2	2	2
L	44.964 - 44.963 (1.7702 - 1.7702)	1	1	1	1	1	1	1	2	2	2	2	2	2	2	2	2
M	44.963 - 44.962 (1.7702 - 1.7702)	1	1	1	1	1	2	2	2	2	2	2	2	2	2	2	2
N	44.962 - 44.961 (1.7702 - 1.7701)	1	1	1	1	2	2	2	2	2	2	2	2	2	2	3	3
P	44.961 - 44.960 (1.7701 - 1.7701)	1	1	1	2	2	2	2	2	2	2	2	2	2	3	3	3
R	44.960 - 44.959 (1.7701 - 1.7700)	1	1	2	2	2	2	2	2	2	2	2	2	3	3	3	3
S	44.959 - 44.958 (1.7700 - 1.7700)	1	2	2	2	2	2	2	2	2	2	2	3	3	3	3	3
T	44.958 - 44.957 (1.7700 - 1.7700)	2	2	2	2	2	2	2	2	2	2	3	3	3	3	3	3
U	44.957 - 44.956 (1.7700 - 1.7699)	2	2	2	2	2	2	2	2	2	3	3	3	3	3	3	3

KBIA0147E

Connecting Rod Bearing Grade Table

Grade	0	1	2	3
Upper / Lower thickness mm (in)	1.499 / 1.495 (0.0590 / 0.0589)	1.503 / 1.499 (0.0592 / 0.0590)	1.507 / 1.503 (0.0593 / 0.0592)	1.511 / 1.507 (0.0595 / 0.0593)
Identification color	Black	Brown	Green	Yellow

Undersize Bearing Usage Guide

- When the specified oil clearance is not obtained with standard size connecting rod bearing, use undersize (U.S.) bearing.
- When using undersize bearing, measure the bearing inner diameter with bearing installed, and grind the crankshaft pin so that the oil clearance satisfies the standard.

A
EM
C
D
E
F
G
H
I
J
K
L
M

CYLINDER BLOCK

[QR25DE]

Bearing Undersize Table

Unit: mm (in)

Size U.S.	Thickness
0.25 (0.0098)	1.624 - 1.632 (0.0639 - 0.0643)

CAUTION:

In grinding the crankshaft pin to use undersize bearings, do not damage the fillet R (All crankshaft pins).

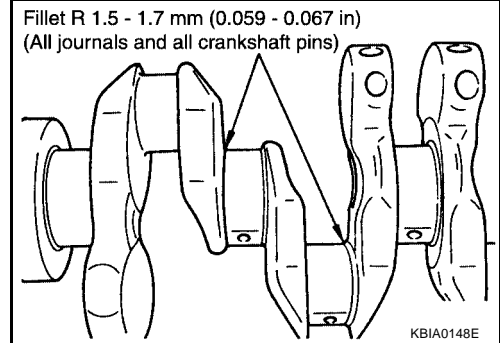

HOW TO SELECT A MAIN BEARING

When New Cylinder Block and Crankshaft are Used:

- "Main Bearing Selection Table" rows correspond to bearing housing grade on rear left side of cylinder block.
 - If there is a corrected stamp mark on the cylinder block, use it as a correct reference.

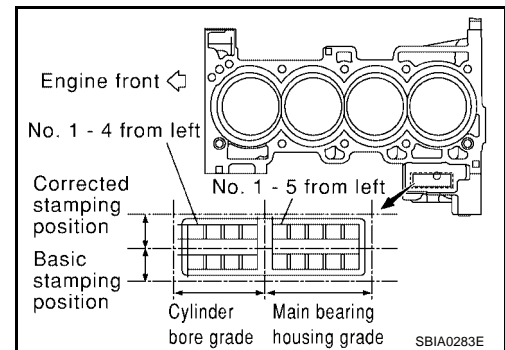

- Apply journal diameter grade stamped on crankshaft front side to column in "Main Bearing Selection Table".

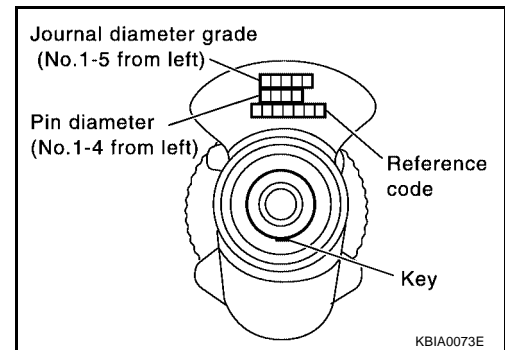

- Find value at crossing of row and column in "Main Bearing Selection Table".

CAUTION:

- There are two main bearing selection tables. One is for odd-numbered journals (1, 3, and 5) and the other is for even-numbered journals (2 and 4). Make certain to use the appropriate table. This is due to differences in the specified clearances.

- Apply the symbol obtained to "Main Bearing Grade Table" to select.

NOTE:

- Service parts are available as a set of both upper and lower.

When Cylinder Block and Crankshaft are Reused:

- Measure inner diameter of cylinder block main bearing housing and outer diameter of crankshaft journal.
- Apply measurement in above step 1 to the "Main Bearing Selection Table".
- Follow steps 3 and 4 in "When New Cylinder Block and Crankshaft are Used".

CYLINDER BLOCK

[QR25DE]

01	UPR	1.973 - 1.976 (0.0777 - 0.0778)	Black / Red	Grade and color are different for upper and lower bearings.
	LWR	1.976 - 1.979 (0.0778 - 0.0779)		
12	UPR	1.976 - 1.979 (0.0778 - 0.0779)	Red / Green	
	LWR	1.979 - 1.982 (0.0779 - 0.0780)		
23	UPR	1.979 - 1.982 (0.0779 - 0.0780)	Green / Yellow	
	LWR	1.982 - 1.985 (0.0780 - 0.0781)		
34	UPR	1.982 - 1.985 (0.0780 - 0.0781)	Yellow / Blue	
	LWR	1.985 - 1.988 (0.0781 - 0.0783)		
45	UPR	1.985 - 1.988 (0.0781 - 0.0783)	Blue / Pink	
	LWR	1.988 - 1.991 (0.0783 - 0.0784)		
56	UPR	1.988 - 1.991 (0.0783 - 0.0784)	Pink / Purple	
	LWR	1.991 - 1.994 (0.0784 - 0.0785)		
67	UPR	1.991 - 1.994 (0.0784 - 0.0785)	Purple / Orange	
	LWR	1.994 - 1.997 (0.0785 - 0.0786)		

Use Undersize Bearing Usage Guide

- Use undersize (U.S.) bearing when oil clearance with standard size main bearing is not within specification.
- When using undersize (U.S.) bearing, measure the bearing inner diameter with the bearing installed and grind journal until oil clearance falls within specification.

Bearing Undersize Table

Unit: mm (in)

Size U.S.	Thickness
0.25 (0.0098)	2.106 - 2.114 (0.0829 - 0.0832)

CAUTION:

Do not damage fillet R when grinding crankshaft journal in order to use an undersize bearing (all journals).

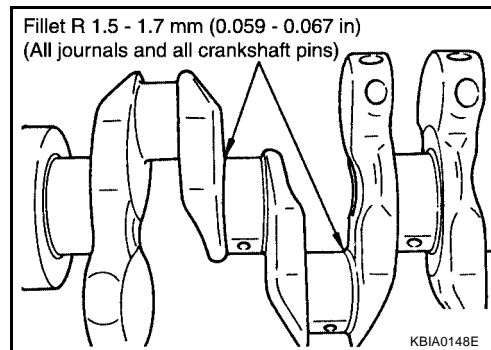

EBS00CG9

Inspection After Disassembly CRANKSHAFT SIDE CLEARANCE

- Using a dial gauge, measure the clearance between the thrust bearings and the crankshaft arm when the crankshaft is moved fully forward or backward.

Standard : 0.10 - 0.26 mm (0.0039 - 0.0102 in)

Limit : 0.30 mm (0.0118 in)

- If the measured value exceeds the limit, replace the thrust bearings, and measure again. If it still exceeds the limit, replace the crankshaft.

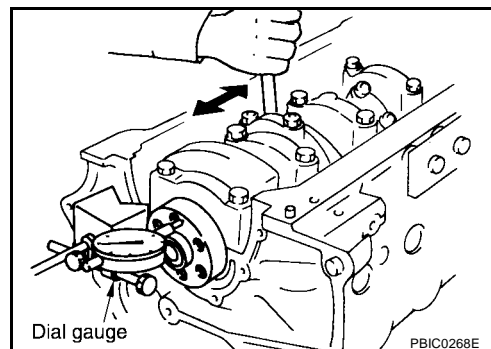

CONNECTING ROD SIDE CLEARANCE

- Measure side clearance between connecting rod and crankshaft arm with feeler gauge.

Standard : 0.20 - 0.35 mm (0.0079 - 0.0138 in)

Limit : 0.50 mm (0.0197 in)

- If the measured value exceeds the limit, replace the connecting rod bearings, and measure again. If it still exceeds the limit, replace the crankshaft also.

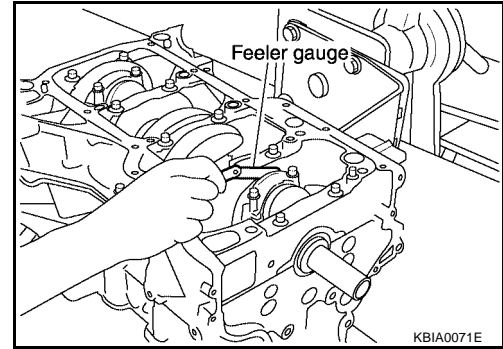

PISTON AND PISTON PIN CLEARANCE

Piston Pin Bore Diameter

- Measure the piston pin bore diameter with an inside micrometer.
- Service parts apply only to grade 0.

Piston pin bore diameter

Grade No. 0 : 19.993 - 19.999 mm (0.7871 - 0.7874 in)

Grade No. 1 : 19.999 - 20.005 mm (0.7874 - 0.7876 in)

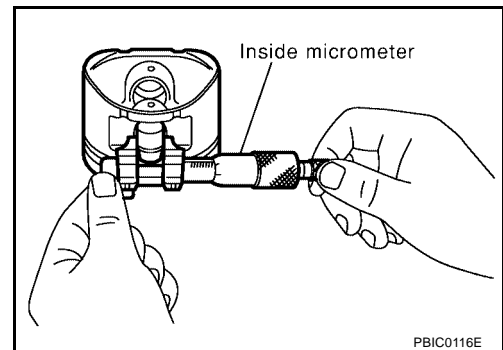

Outer Diameter of Piston Pin

- Measure outer diameter of piston pin with a micrometer.

Piston pin outer diameter

Grade No. 0 : 19.989 - 19.995 mm (0.7870 - 0.7872 in)

Grade No. 1 : 19.995 - 20.001 mm (0.7872 - 0.7874 in)

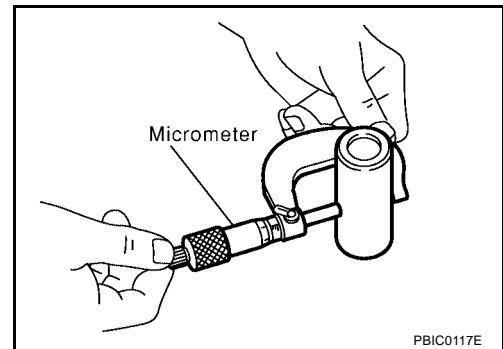

Piston to Piston Pin Clearance

(Piston to piston pin clearance) = (Piston pin bore diameter) – (Outer diameter of piston pin)

Standard : 0.002 - 0.006 mm (0.0001 - 0.0002 in)

- If clearance exceeds specification, replace either or both of piston/piston pin assembly and connecting rod assembly with reference to specification of each parts.
- Refer to piston selection table to replace piston/piston pin assembly. Refer to [EM-169, "HOW TO SELECT A PISTON"](#) .
- Refer to connecting rod bearing selection table to replace connecting rod. Refer to [EM-170, "HOW TO SELECT A CONNECTING ROD BEARING"](#) .

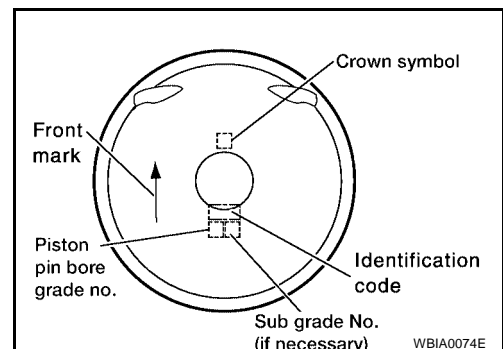

NOTE:

- The connecting rod small end grade and piston pin hole (piston pin) grade are provided only for the parts installed at the plant. For service parts, no grades can be selected. Only 0 grade is available.
- Refer to [EM-178, "CONNECTING ROD BUSHING OIL CLEARANCE \(SMALL END\)"](#) for the values for each grade at the plant.
- Regarding marks on piston head, refer to [EM-169, "HOW TO SELECT A PISTON"](#).

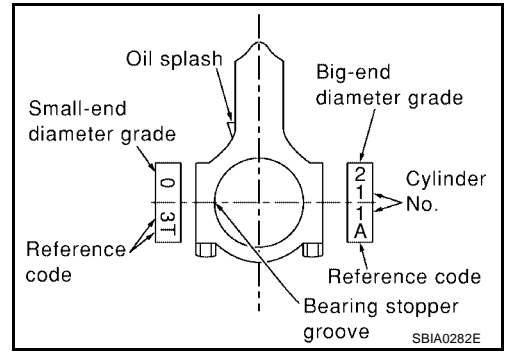

PISTON RING SIDE CLEARANCE

- Measure side clearance of piston ring and piston ring groove with feeler gauge.

Standard

Top ring : 0.045 - 0.080 mm (0.0018 - 0.0031 in)

2nd ring : 0.030 - 0.070 mm (0.0012 - 0.0028 in)

Oil ring : 0.065 - 0.135 mm (0.0026 - 0.0053 in)

Limit

Top ring : 0.11 mm (0.0043 in)

2nd ring : 0.10 mm (0.004 in)

Oil ring : —

- If out of specification, replace piston and/or piston ring assembly.

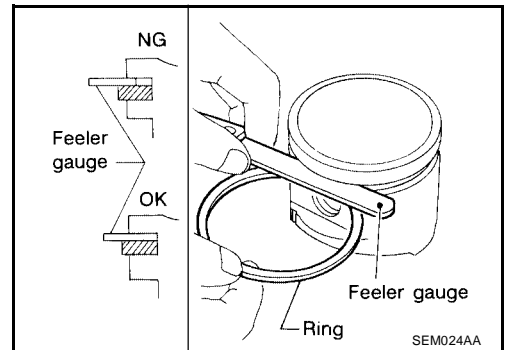

PISTON RING END GAP

- Check if inner diameter of cylinder bore is within specification. Refer to [EM-180, "PISTON TO CYLINDER BORE CLEARANCE"](#).
- Insert piston ring until middle of cylinder with piston, and measure gap.

Standard

Top ring : 0.21 - 0.31 mm (0.0083 - 0.0122 in)

2nd ring : 0.32 - 0.47 mm (0.0126 - 0.0185 in)

Oil ring : 0.20 - 0.60 mm (0.0079 - 0.0236 in)

Limit

Top ring : 0.54 mm (0.0213 in)

2nd ring : 0.67 mm (0.0264 in)

Oil ring : 0.95 mm (0.0374 in)

- If out of specification, replace piston ring. If gap still exceeds the limit even with a new ring, re-bore cylinder and use oversized piston and piston ring.

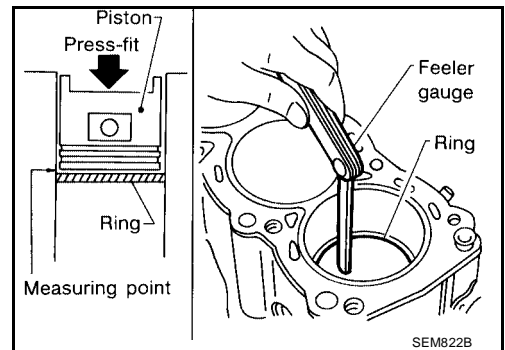

CONNECTING ROD BEND AND TORSION

- Check with connecting rod aligner.

CYLINDER BLOCK

[QR25DE]

- Bend limit** : 0.15 mm (0.0059 in) per 100 mm (3.94 in) length
- Torsion limit** : 0.30 mm (0.0118 in) per 100 mm (3.94 in) length

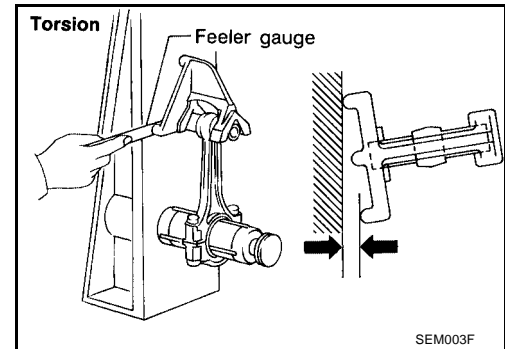

SEM003F

- If it exceeds the limit, replace connecting rod assembly.

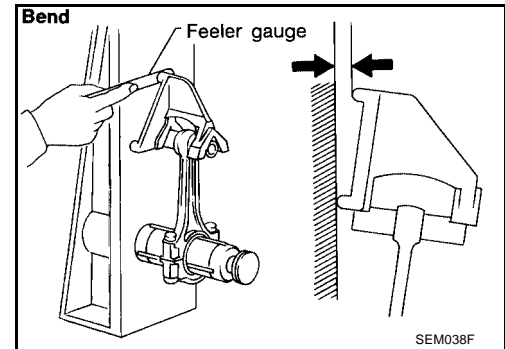

SEM038F

CONNECTING ROD BEARING (BIG END)

- Install the connecting rod cap without the connecting rod bearing installed. After tightening the connecting rod bolt to the specified torque, measure the connecting rod big end inner diameter using an inside micrometer.

Standard : 48.000 - 48.013 mm (1.8898 - 1.8903 in)

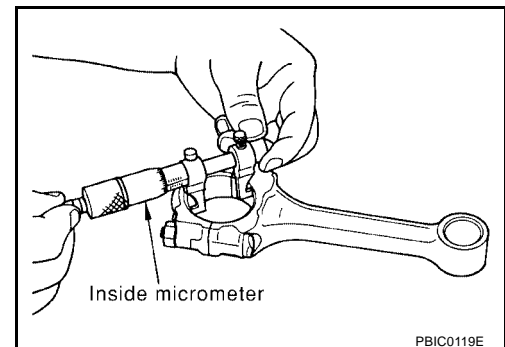

PBIC0119E

CONNECTING ROD BUSHING OIL CLEARANCE (SMALL END)

Inner Diameter of Connecting Rod (Small End)

- Measure inner diameter of bushing.

Connecting rod small end inner diameter

Grade No. 0 : 20.000 - 20.006 mm (0.7874 - 0.7876 in)

Grade No. 1 : 20.006 - 20.012 mm (0.7876 - 0.7879 in)

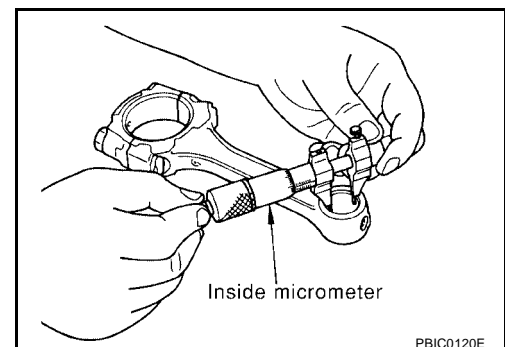

PBIC0120E

Outer Diameter of Piston Pin

- Measure outer diameter of piston pin.

Piston pin outer diameter

Grade No. 0 : 19.989 - 19.995 mm (0.7870 - 0.7872 in)

Grade No. 1 : 19.995 - 20.001 mm (0.7872 - 0.7874 in)

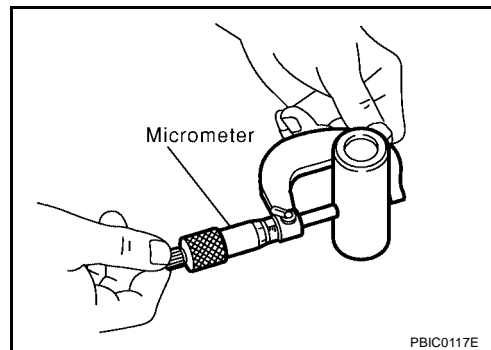

Connecting Rod Oil Clearance (Small End)

(Connecting rod small end oil clearance) = (Inner diameter of connecting rod small end) – (Outer diameter of piston pin)

Standard : 0.005 - 0.017 mm (0.0002 - 0.0007 in)

- If the measured value exceeds the standard, replace the connecting rod assembly and/or piston and piston pin assembly.
- If replacing the piston and piston pin assembly, refer to the "Piston Selection Table" to select the piston corresponding to the applicable bore grade of the cylinder block to be used. Refer to [EM-169, "HOW TO SELECT A PISTON"](#).

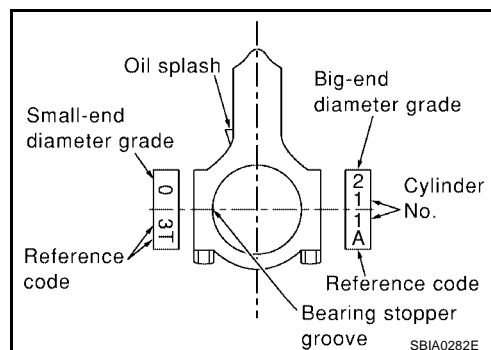

Factory Installed Parts Grading:

- Service parts apply only to grade 0.

Grade	Unit: mm (in)	
	0	1
Connecting rod small end inner diameter	20.000 - 20.006 (0.7874 - 0.7876)	20.006 - 20.012 (0.7876 - 0.7879)
Piston pin outer diameter	19.989 - 19.995 (0.7870 - 0.7872)	19.995 - 20.001 (0.7872 - 0.7874)
Piston pin bore diameter	19.993 - 19.999 (0.7871 - 0.7874)	19.999 - 20.005 (0.7874 - 0.7876)

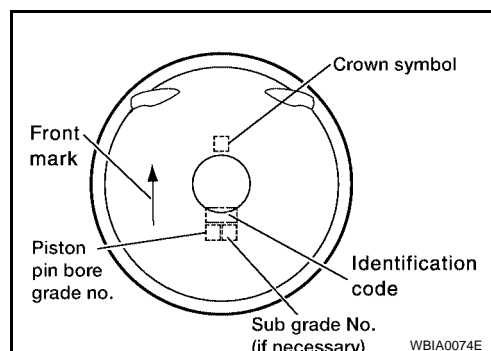

CYLINDER BLOCK DISTORTION

- Using a scraper, remove gasket on the cylinder block surface, and also remove oil, scale, carbon, or other contamination.

CAUTION:

Be careful not to allow gasket debris to enter the oil or coolant passages.

- Measure the distortion on the block upper face at some different points in 6 directions.

Limit : 0.1 mm (0.004 in)

- If out of the distortion limit, replace the cylinder block.

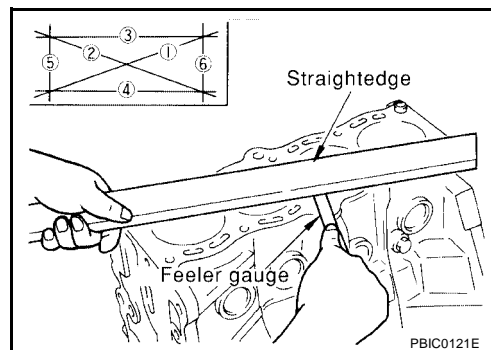

INNER DIAMETER OF MAIN BEARING HOUSING

- Install the main bearing caps with the main bearings removed and tighten the mounting bolts to the specified torque. Refer to [EM-164, "ASSEMBLY"](#) .
- Using a bore gauge, measure the inner diameter of the main bearing housing. Refer to [EM-190, "CYLINDER BLOCK"](#) .
- If out of the standard, replace the cylinder block and lower cylinder block assembly.

NOTE:

These components cannot be replaced as a single unit because they were processed together.

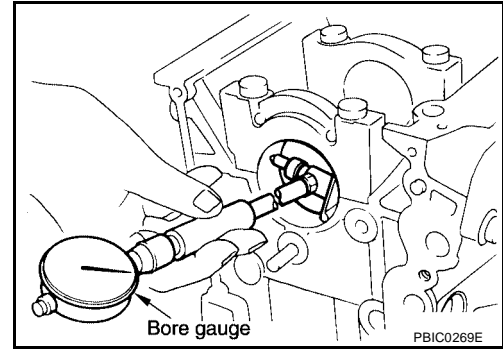

PISTON TO CYLINDER BORE CLEARANCE

Inner Diameter of Cylinder Bore

- Using a bore gauge, measure cylinder bore for wear, out-of-round and taper at 6 different points on each cylinder. (X and Y directions at A, B and C). The Y axis is in the longitudinal direction of the engine.

NOTE:

When determining cylinder bore grade, measure cylinder bore at B position.

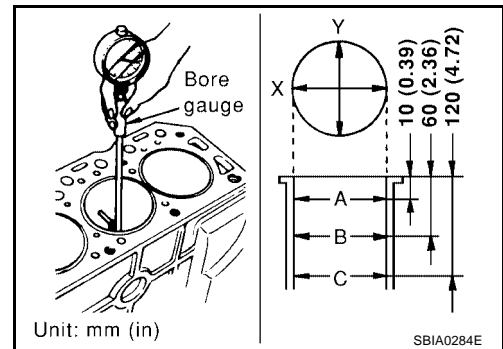

Cylinder bore inner diameter

Grade No. 1 : 89.000 - 89.010 mm (3.5039 - 3.5043 in)

Grade No. 2 : 89.010 - 89.020 mm (3.5043 - 3.5047 in)

Grade No. 3 : 89.020 - 89.030 mm (3.5047 - 3.5051 in)

Wear limit: 0.2 mm (0.008 in)

Out-of-round (difference between, X – Y): 0.015 mm (0.0006 in)

Taper limit (difference between, C – A): 0.01 mm (0.0004 in)

- If the measured value rebore exceeds the limit, or if there are scratches and/or seizure on the cylinder inner wall, hone the inner wall.
- An oversize piston is provided. When using an oversize piston, rebore the cylinder so that the clearance of the piston cylinder satisfies the standard.

Piston oversize (OS)

Clearance : 0.2 mm (0.008 in)

Diameter : 89.180 - 89.210 mm (3.5110 - 3.5122 in)

Outer Diameter of Piston

- Measure piston skirt diameter (A).

Piston skirt diameter

Grade No. 1 : 88.980 - 88.990 mm (3.5031 - 3.5035 in)

Grade No. 2 : 88.990 - 89.000 mm (3.5035 - 3.5039 in)

Grade No. 3 : 89.000 - 89.010 mm (3.5039 - 3.5043 in)

Oversize clearance : 0.20 mm (0.0079 in)

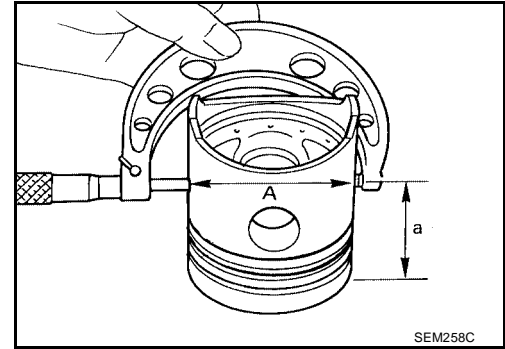

- Measure point (a) (distance from the top): 42 mm (1.65 in)

Piston to Cylinder Bore Clearance

- Calculate by outer diameter of piston skirt and inner diameter of cylinder (direction X, position B).
(Clearance) = (Inner diameter of cylinder) – (Outer diameter of piston skirt).

Standard : 0.010 - 0.030 mm (0.0004 - 0.0012 in)

Limit : 0.08 mm (0.0031 in)

- If it exceeds the limit, replace piston/piston pin assembly.

Reboring Cylinder Bore

1. Cylinder bore size is determined by adding piston-to-bore clearance to piston diameter "A".

Rebored size calculation: $D = A + B - C$

D: Bored diameter

A: Piston diameter as measured

B: Piston-to-bore clearance (standard value)

C: Honing allowance 0.02 mm (0.0008 in)

2. Install main bearing caps, and tighten to the specified torque. Otherwise, cylinder bores may be distorted in final assembly.
3. Cut cylinder bores.
 - **When any cylinder needs boring, all other cylinders must also be bored.**
 - **Do not cut too much out of cylinder bore at a time. Cut only 0.05 mm (0.0020 in) or so in diameter at a time.**
- 4.hone cylinders to obtain specified piston-to-bore clearance.
5. Measure finished cylinder bore for out-of-round and taper.
 - **Measurement should be done after cylinder bore cools down.**

OUTER DIAMETER OF CRANKSHAFT MAIN JOURNAL

- Measure outer diameter of crankshaft main journals "Dm".

Standard : 54.955 - 54.979 mm (2.1636 - 2.1645 in)
"Dm"

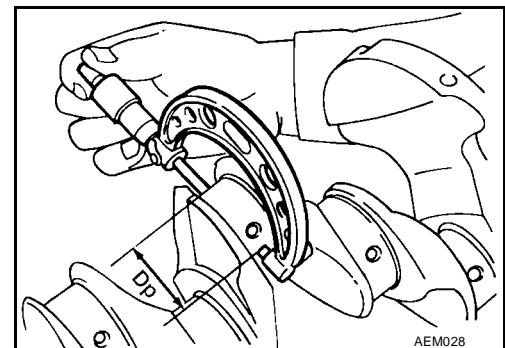

OUTER DIAMETER OF CRANKSHAFT PIN JOURNAL

- Measure outer diameter of crankshaft pin journals.
 - Standard** : 44.956 - 44.974 mm (1.7699 - 1.7706 in)
 - "Dp"**

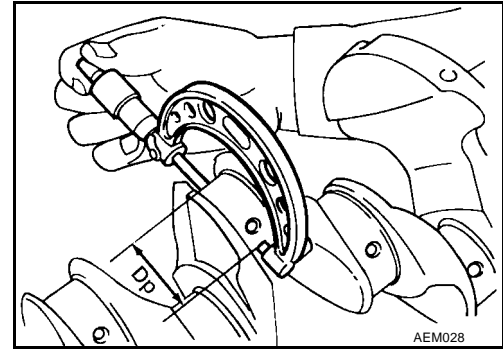

OUT-OF-ROUND AND TAPER OF CRANKSHAFT

- Using a micrometer, measure the dimensions at four different points shown in the figure on each journal and pin.
- Out-of-round is indicated by the difference in dimensions between "X" and "Y" at "A" and "B".
- Taper is indicated by the difference in dimension between "A" and "B" at "X" and "Y".

Limit

Out-of-round (X - Y) : 0.005 mm (0.0002 in)

Taper (A - B) : 0.005 mm (0.0002 in)

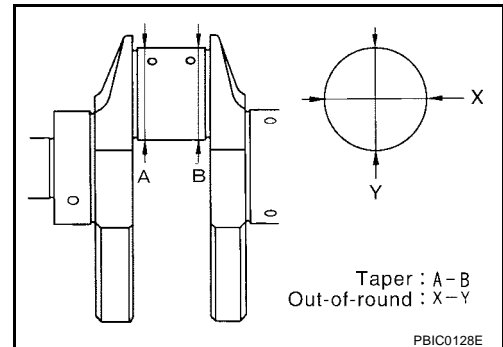

CRANKSHAFT RUNOUT

- Place a V-block on a precise flat table to support the journals on both ends of the crankshaft.
- Place a dial gauge straight up on the No. 3 journal.
- While rotating the crankshaft, read the movement of the pointer on the dial gauge, the total indicator reading.

Limit : 0.05 mm (0.002 in)

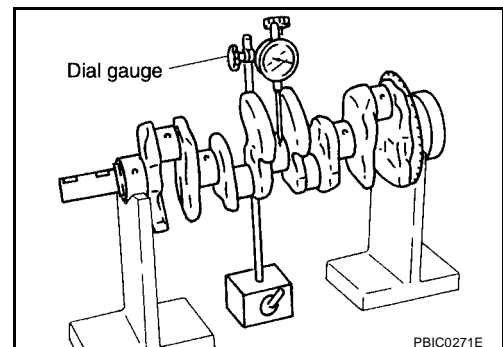

OIL CLEARANCE OF CONNECTING ROD BEARING

Method of Measurement

- Install the connecting rod bearings to the connecting rod and the cap, and tighten the connecting rod bolts to the specified torque. Using an inside micrometer measure the inner diameter of connecting rod bearing.
 - (Oil clearance) = (Inner diameter of connecting rod bearing) - (Outer diameter of crankshaft pin)

Standard : 0.028 - 0.045 mm (0.0011 - 0.0018 in)

Limit : 0.10 mm (0.0039 in)

- If clearance cannot be adjusted within the standard, grind crankshaft pin and use undersized bearing. Refer to [EM-170, "HOW TO SELECT A CONNECTING ROD BEARING"](#).

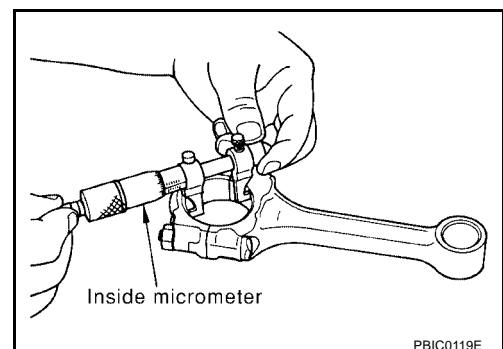

Method of Using Plastigage

- Remove oil and dust on the crankshaft pin and the surfaces of each bearing completely.
- Cut the Plastigage slightly shorter than the bearing width, and place it in crankshaft axial direction, avoiding oil holes.
- Install the connecting rod bearings to the connecting rod cap, and tighten the connecting rod bolts to the specified torque.

CAUTION:

Never rotate the crankshaft.

- Remove the connecting rod cap and bearings, and using the scale on the Plastigage bag, measure the Plastigage width.

NOTE:

The procedure when the measured value exceeds the limit is same as that described in the method by calculation.

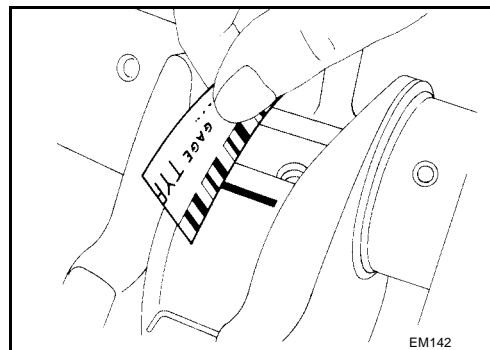

OIL CLEARANCE OF MAIN BEARING

Method of Measurement

- Install the main bearings to the cylinder block and bearing cap. Measure the main bearing inner diameter with the bearing cap bolt tightened to the specified torque.
(Oil clearance) = (Inner diameter of main bearing) – (Outer diameter of crankshaft journal)

Standard:

No. 1, 3, and 5 journals : 0.012 - 0.022 mm (0.0005 - 0.0009 in)

No. 2 and 4 journals : 0.018 - 0.028 mm (0.0007 - 0.0011 in)

Limit : 0.1 mm (0.004 in)

- If the measured value exceeds the limit, select main bearings referring to the main bearing inner diameter and crankshaft journal outer diameter, so that the oil clearance satisfies the standard. Refer to [EM-172, "HOW TO SELECT A MAIN BEARING"](#).

Method of Using Plastigage

- Remove oil and dust on the crankshaft journal and the surfaces of each bearing completely.
- Cut the Plastigage slightly shorter than the bearing width, and place it in crankshaft axial direction, avoiding oil holes.
- Tighten the main bearing bolts to the specified torque.

CAUTION:

Never rotate the crankshaft.

- Remove the bearing cap and bearings, and using the scale on the Plastigage bag, measure the Plastigage width.

NOTE:

The procedure when the measured value exceeds the limit is same as that described in the "Method by Calculation".

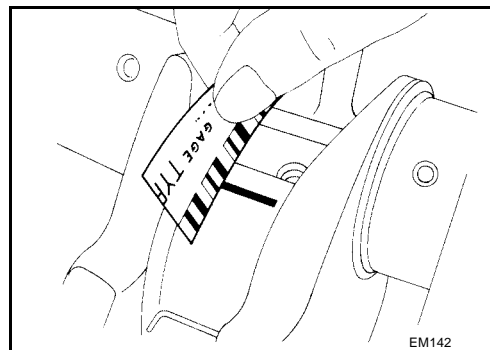

CRUSH HEIGHT OF MAIN BEARING

- When the bearing cap is removed after being tightened to the specified torque with main bearings installed, the tip end of bearing must protrude.

Standard : There must be crush height.

- If the standard is not met, replace main bearings.

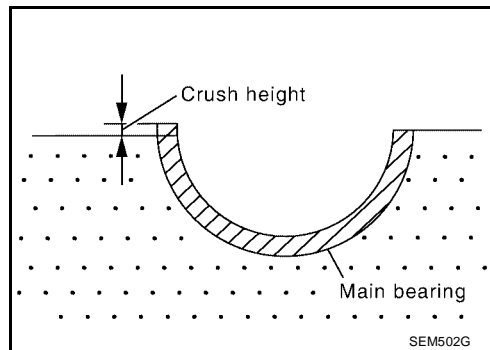

OUTER DIAMETER OF LOWER CYLINDER BLOCK MOUNTING BOLT

- Perform only with M10 (0.39 in) bolts.
- Measure outer diameters (d1, d2) at two positions as shown.
- Measure d2 at a point within block A.
- When the value of d1- d2 exceeds the limit (a large difference in dimensions), replace the bolt with a new one.

Limit : 0.13 mm (0.0051 in) or more

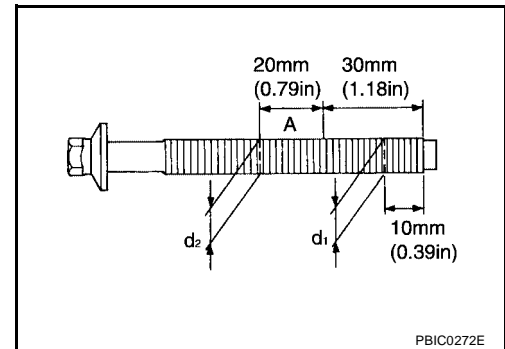

PBIC0272E

OUTER DIAMETER OF CONNECTING ROD BOLT

- Measure outer diameter (d) at position shown in the figure.
- When "d" exceeds the limit (when it becomes thinner), replace the bolt with a new one.

Limit : 7.75 mm (0.3051 in) or less

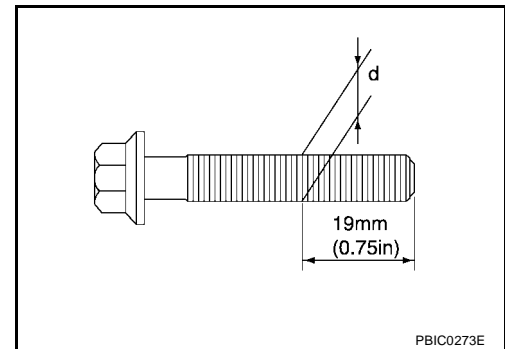

PBIC0273E

MOVEMENT AMOUNT OF FLYWHEEL (M/T MODEL)

NOTE:

- Inspection for double mass flywheel only.
- Do not disassemble double mass flywheel.

Flywheel Runout

- Measure runout of flywheel contact surface to the clutch with a dial gauge.
- Measure runout at 210 mm (8.27 in) dia.

Standard : 0.45 mm (0.0177 in) or less

Limit : 1.3 mm (0.051 in) or less

- When measured value exceeds the limit, replace the flywheel with a new one.

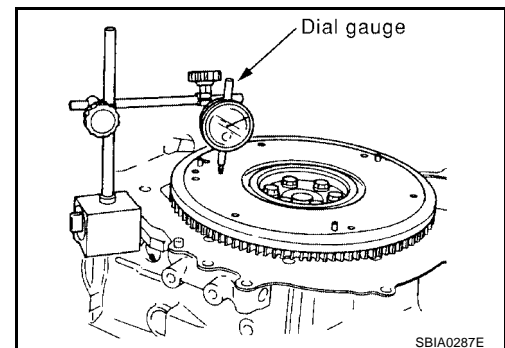

SBIA0287E

Movement Amount in Rotation Direction

- Check the movement amount in the following procedure.
 1. Install a bolt to clutch cover mounting hole, and place a torque wrench on the extended line of the flywheel center line.
 - Tighten bolt to keep it from loosening at a force of 9.8 N·m (1 kg·m, 87 in·lb).

CYLINDER BLOCK

[QR25DE]

- Put a mating mark on circumferences of the two flywheel masses without applying any load (measurement standard points).
- Apply a force of 9.8 N·m (1 kg·m, 87 in·lb) in each direction, and mark the movement amount on the mass on the transaxle side.
- Measure dimensions of movement amounts A and B on circumference of the flywheel on the transaxle side.

Standard : 28.3 mm (1.114 in) or less

- When measured value is outside the standard, replace flywheel.

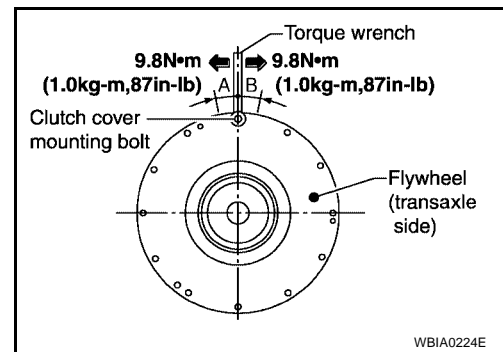

A

EM

C

D

E

F

G

H

I

J

K

L

M

SERVICE DATA AND SPECIFICATIONS (SDS)

[QR25DE]

SERVICE DATA AND SPECIFICATIONS (SDS)

PF0:00030

Standard and Limit GENERAL SPECIFICATIONS

EBS00CGA

Cylinder arrangement		In-line 4
Displacement cm ³ (cu in)		2,488 (151.82)
Bore and stroke mm (in)		89.0 x 100 (3.50 - 3.94)
Valve arrangement		DOHC
Firing order		1-3-4-2
Number of piston rings	Compression	2
	Oil	1
Compression ratio		9.5
Compression pressure kPa (kg/cm ² , psi) / 250 rpm	Standard	1,250 (12.8, 181.3)
	Minimum	1,060 (10.8, 153.7)
	Differential limit between cylinders	100 (1.0, 14)

Valve timing	<p style="text-align: right;">PBIC0187E</p>				
--------------	---	--	--	--	--

Unit: degree

a	b	c	d	e	f
224	244	0	64	3	41

DRIVE BELTS

Tension of drive belts	Auto adjustment by auto-tensioner
------------------------	-----------------------------------

INTAKE MANIFOLD AND EXHAUST MANIFOLD

Unit: mm (in)

		Limit
Surface distortion	Intake manifold collector	0.1 (0.004)
	Intake manifold	0.1 (0.004)
	Exhaust manifold	0.3 (0.012)

SPARK PLUG

Make	NGK
Standard type	PLFR5A-11 (Platinum type)
Hot type	PLFR4A-11 (Platinum type)
Cold type	PLFR6A-11 (Platinum type)
Gap (nominal)	1.1 mm (0.043 in)

SERVICE DATA AND SPECIFICATIONS (SDS)

[QR25DE]

CYLINDER HEAD

Unit: mm (in)

Limit

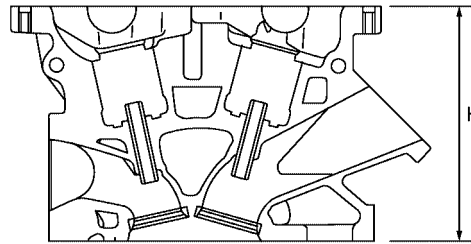

Nominal cylinder head height:
H = 129.4 mm (5.09 in)

PBIC0283E

Head surface distortion

0.1 (0.004)

VALVE

Valve Dimensions

Unit: mm (in)

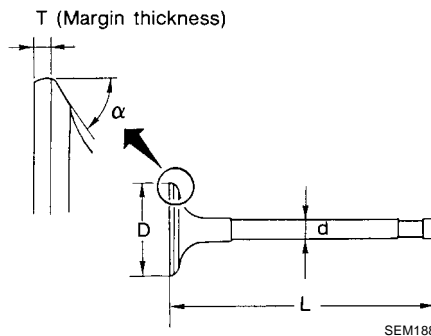

Valve head diameter "D"	Intake	35.5 - 35.8 (1.398 - 1.409)
	Exhaust	30.5 - 30.8 (1.201 - 1.213)
Valve length "L"	Intake	97.16 (3.8252)
	Exhaust	98.82 (3.8905)
Valve stem diameter "d"	Intake	5.965 - 5.980 (0.2348 - 0.2354)
	Exhaust	5.955 - 5.970 (0.2344 - 0.2350)
Valve seat angle "α"	Intake	45°15' - 45°45'
	Exhaust	
Valve margin "T"	Intake	1.1 (0.043)
	Exhaust	1.3 (0.051)

Valve Clearance

Unit: mm (in)

	Cold* (reference data)	Hot
Intake	0.24 - 0.32 (0.009 - 0.013)	0.32 - 0.40 (0.013 - 0.016)
Exhaust	0.26 - 0.34 (0.010 - 0.013)	0.33 - 0.41 (0.013 - 0.016)

*: Approximately 20°C (68 °F)

SERVICE DATA AND SPECIFICATIONS (SDS)

[QR25DE]

Available Valve Lifter

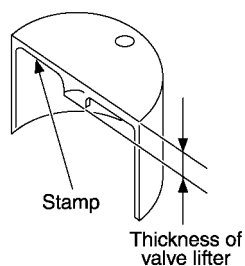

KBIA0119E

Thickness mm (in)	Identification mark
6.96 (0.2740)	696
6.98 (0.2748)	698
7.00 (0.2756)	700
7.02 (0.2764)	702
7.04 (0.2772)	704
7.06 (0.2780)	706
7.08 (0.2787)	708
7.10 (0.2795)	710
7.12 (0.2803)	712
7.14 (0.2811)	714
7.16 (0.2819)	716
7.18 (0.2827)	718
7.20 (0.2835)	720
7.22 (0.2843)	722
7.24 (0.2850)	724
7.26 (0.2858)	726
7.28 (0.2866)	728
7.30 (0.2874)	730
7.32 (0.2882)	732
7.34 (0.2890)	734
7.36 (0.2898)	736
7.38 (0.2906)	738
7.40 (0.2913)	740
7.42 (0.2921)	742
7.44 (0.2929)	744
7.46 (0.2937)	746

Valve Spring

Free height standard mm (in)	Intake (blue)	44.84 - 45.34 (1.7654 - 1.7850)
	Exhaust (yellow)	45.28 - 45.78 (1.7827 - 1.8024)
Pressure standard N (kg-force, lb-force) at height mm (in)	Intake (blue) and Exhaust (yellow)	151 - 175 (15.4 - 17.8, 34 - 39) at 35.30 (1.390)
Out-of-square mm (in)		1.9 (0.0748)
Installation height mm (in)	Intake (blue) and Exhaust (yellow)	35.30 (1.390)

SERVICE DATA AND SPECIFICATIONS (SDS)

[QR25DE]

Height during valve open mm (in)	Intake (blue)	24.94 (0.9819)
	Exhaust (yellow)	26.39 (1.0390)
Load with valve open N (kg-force, lb-force)	Intake (blue)	358 - 408 (36.5 - 41.6, 80 - 92)
	Exhaust (yellow)	325 - 371 (33.1 - 37.8, 73 - 83)

Valve Lifter

Unit: mm (in)

	Standard
Valve lifter outer diameter	33.965 - 33.980 (1.3372 - 1.3378)
Valve lifter guide bore diameter	34.000 - 34.021 (1.3386 - 1.3394)
Clearance between lifter and lifter guide bore	0.020 - 0.056 (0.0008 - 0.0022)

Valve Guide

Unit: mm (in)

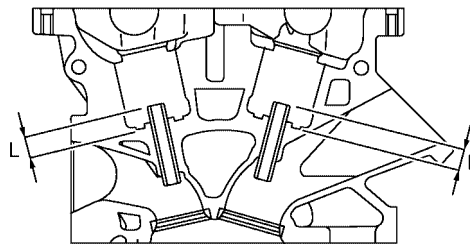

PBIC0184E

		Standard	Service
Valve guide	Outer diameter	10.023 - 10.034 (0.3946 - 0.3950)	10.223 - 10.234 (0.4025 - 0.4029)
	Inner diameter (Finished size)	6.000 - 6.018 (0.2362 - 0.2369)	
Valve guide bore diameter		9.975 - 9.996 (0.3927 - 0.3935)	10.175 - 10.196 (0.4006 - 0.4014)
Interference fit of valve guide		0.027 - 0.059 (0.0011 - 0.0023)	
Standard			
Valve to guide clearance	Intake	0.020 - 0.053 (0.0008 - 0.0021)	
	Exhaust	0.030 - 0.063 (0.0012 - 0.0025)	
Projection length "L"	Intake	10.1 - 10.3 (0.398 - 0.406)	
	Exhaust	10.0 - 10.4 (0.394 - 0.409)	

Valve Seat

Unit: mm (in)

*: Machining data

Contacting width (W)
; 1.05 - 1.35 (0.0413 - 0.0531)

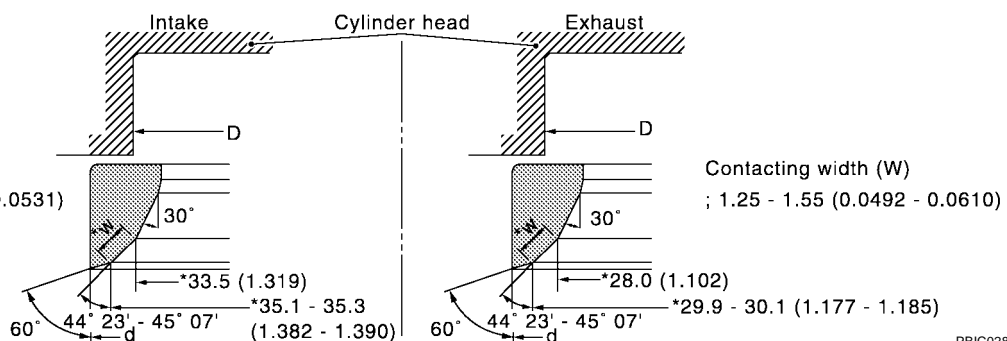

PBIC0284E

	Standard	Service
--	----------	---------

SERVICE DATA AND SPECIFICATIONS (SDS)

[QR25DE]

Cylinder head seat recess diameter (D)	Intake	36.500 - 36.516 (1.4370 - 1.4376)	37.000 - 37.016 (1.4567 - 1.4573)
	Exhaust	31.500 - 31.516 (1.2402 - 1.2408)	32.000 - 32.016 (1.2598 - 1.2605)
Valve seat interference fit	Intake	0.081 - 0.113 (0.0032 - 0.0044)	
	Exhaust	0.084 - 0.116 (0.0033 - 0.0046)	
Valve seat outer diameter (d)	Intake	36.597 - 36.613 (1.4408 - 1.4415)	37.097 - 37.113 (1.4605 - 1.4611)
	Exhaust	31.600 - 31.616 (1.2441 - 1.2447)	32.100 - 32.116 (1.2638 - 1.2644)

CAMSHAFT AND CAMSHAFT BEARING

Unit: mm (in)

	Standard
Camshaft runout [TIR*]	Less than 0.04 (0.0016)

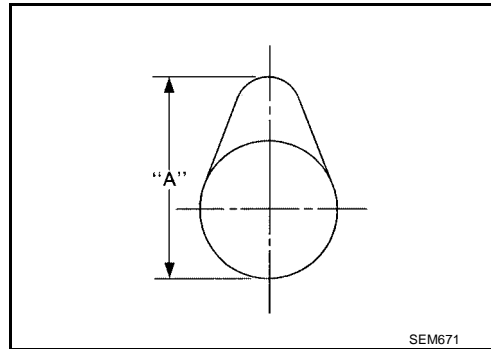

Cam height "A"	Intake	45.665 - 45.855 (1.7978 - 1.8053)
	Exhaust	43.975 - 44.165 (1.7313 - 1.7388)
Outer diameter of camshaft journal	No. 1	27.935 - 27.955 (1.0998 - 1.1006)
	No. 2, 3, 4, 5	23.435 - 23.455 (0.9226 - 0.9234)
Inner diameter of camshaft bracket	No. 1	28.000 - 28.021 (1.1024 - 1.1032)
	No. 2, 3, 4, 5	23.500 - 23.521 (0.9252 - 0.9260)
Camshaft journal clearance		0.045 - 0.086 (0.0018 - 0.0034)
Camshaft end play		0.115 - 0.188 (0.0045 - 0.0074)
Camshaft sprocket runout [TIR*]		Less than 0.15 (0.0059)

*: Total indicator reading

CYLINDER BLOCK

Unit: mm (in)

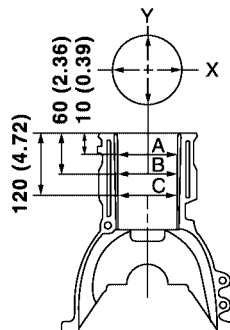

Surface distortion	Limit	0.1 (0.004)
--------------------	-------	-------------

SERVICE DATA AND SPECIFICATIONS (SDS)

[QR25DE]

Cylinder bore	Inner diameter	Standard	Grade No. 1	89.000 - 89.010 (3.5039 - 3.5043)	A
			Grade No. 2	89.010 - 89.020 (3.5043 - 3.5047)	
			Grade No. 3	89.020 - 89.030 (3.5047 - 3.5051)	
Wear limit			0.2 (0.008)		EM
Out-of-round (X - Y)			Less than 0.015 (0.0006)		
Taper (C - A)			Less than 0.01 (0.0004)		
Main journal inner diameter grade (Without bearing)	Grade No. A	58.944 - 58.945 (2.3206 - 2.3207)		C	
	Grade No. B	58.945 - 58.946 (2.3207 - 2.3207)			
	Grade No. C	58.946 - 58.947 (2.3207 - 2.3207)			
	Grade No. D	58.947 - 58.948 (2.3207 - 2.3208)		D	
	Grade No. E	58.948 - 58.949 (2.3208 - 2.3208)			
	Grade No. F	58.949 - 58.950 (2.3208 - 2.3209)			
	Grade No. G	58.950 - 58.951 (2.3209 - 2.3209)			
	Grade No. H	58.951 - 58.952 (2.3209 - 2.3209)		E	
	Grade No. J	58.952 - 58.953 (2.3209 - 2.3210)			
	Grade No. K	58.953 - 58.954 (2.3210 - 2.3210)			
	Grade No. L	58.954 - 58.955 (2.3210 - 2.3211)			
	Grade No. M	58.955 - 58.956 (2.3211 - 2.3211)		F	
	Grade No. N	58.956 - 58.957 (2.3211 - 2.3211)			
	Grade No. P	58.957 - 58.958 (2.3211 - 2.3212)			
	Grade No. R	58.958 - 58.959 (2.3212 - 2.3212)			
	Grade No. S	58.959 - 58.960 (2.3212 - 2.3213)		G	
	Grade No. T	58.960 - 58.961 (2.3213 - 2.3213)			
Grade No. U	58.961 - 58.962 (2.3213 - 2.3213)				
Grade No. V	58.962 - 58.963 (2.3213 - 2.3214)				
Grade No. W	58.963 - 58.964 (2.3214 - 2.3214)		H		
Grade No. X	58.964 - 58.965 (2.3214 - 2.3215)				
Grade No. Y	58.965 - 58.966 (2.3215 - 2.3215)				
Grade No. 4	58.966 - 58.967 (2.3215 - 2.3215)		I		
Grade No. 7	58.967 - 58.968 (2.3215 - 2.3216)				
Difference in inner diameter between cylinders	Standard	Less than 0.03 (0.0012)		J	

PISTON, PISTON RING, AND PISTON PIN

Available Piston

Unit: mm (in)

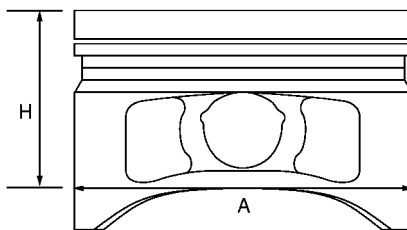

PBIC0188E

Piston skirt diameter "A"	Standard	Grade No. 1	88.980 - 88.990 (3.5031 - 3.5035)		
		Grade No. 2	88.990 - 89.000 (3.5035 - 3.5039)		
		Grade No. 3	89.000 - 89.010 (3.5039 - 3.5043)		
		0.20 (0.0079) oversize clearance (service)	89.180 - 89.210 (3.5110 - 3.5122)		
"H" dimension			42 (1.65)		
Piston pin bore diameter	Grade No. 0	19.993 - 19.999 (0.7871 - 0.7874)			
	Grade No. 1	19.999 - 20.005 (0.7874 - 0.7876)			

SERVICE DATA AND SPECIFICATIONS (SDS)

[QR25DE]

Piston to cylinder bore clearance	Standard	0.010 - 0.030 (0.0004 - 0.0012)
	Limit	0.08 (0.0031)

Piston Ring

Unit: mm (in)

		Standard	Limit
Side clearance	Top	0.045 - 0.080 (0.0018 - 0.0031)	0.11 (0.0043)
	2nd	0.030 - 0.070 (0.0012 - 0.0028)	0.10 (0.004)
	Oil ring	0.065 - 0.135 (0.0026 - 0.0053)	—
End gap	Top	0.21 - 0.31 (0.0083 - 0.0122)	0.54 (0.0213)
	2nd	0.32 - 0.47 (0.0126 - 0.0185)	0.67 (0.0264)
	Oil (rail ring)	0.20 - 0.60 (0.0079 - 0.0236)	0.95 (0.0374)

Piston Pin

Unit: mm (in)

Piston pin outer diameter	Grade No.0	19.989 - 19.995 (0.7870 - 0.7872)
	Grade No.1	19.995 - 20.001 (0.7872 - 0.7874)
Piston pin to piston clearance		0.002 - 0.006 (0.0001 - 0.0002)
Piston pin to connecting rod oil clearance	Standard	0.005 - 0.017 (0.0002 - 0.0007)

CONNECTING ROD

Unit: mm (in)

Center distance		143.00 - 143.10 (5.63 - 5.63)
Bend [per 100 (3.94)]	Limit	0.15 (0.0059)
Torsion [per 100 (3.94)]	Limit	0.30 (0.0118)
Connecting rod small end inner diameter		22.000 - 22.012 (0.7874 - 0.7879)
Connecting rod small end inner diameter*	Grade No. 0	20.000 - 20.006 (0.7874 - 0.7876)
	Grade No. 1	20.006 - 20.012 (0.7876 - 0.7879)
Connecting rod big end inner diameter		48.000 - 48.013 (1.8898 - 1.8903)
Side clearance	Standard	0.20 - 0.35 (0.0079 - 0.0138)
	Limit	0.50 (0.0197)
Connecting rod bearing housing	Grade No. 0	48.000 - 48.001 (1.8898 - 1.8898)
	Grade No. 1	48.001 - 48.002 (1.8898 - 1.8898)
	Grade No. 2	48.002 - 48.003 (1.8898 - 1.8899)
	Grade No. 3	48.003 - 48.004 (1.8899 - 1.8899)
	Grade No. 4	48.004 - 48.005 (1.8899 - 1.8899)
	Grade No. 5	48.005 - 48.006 (1.8899 - 1.8900)
	Grade No. 6	48.006 - 48.007 (1.8900 - 1.8900)
	Grade No. 7	48.007 - 48.008 (1.8900 - 1.8901)
	Grade No. 8	48.008 - 48.009 (1.8901 - 1.8901)
	Grade No. 9	48.009 - 48.010 (1.8901 - 1.8902)
	Grade No. A	48.010 - 48.011 (1.8902 - 1.8902)
	Grade No. B	48.011 - 48.012 (1.8902 - 1.8902)
Grade No. C	48.012 - 48.013 (1.8902 - 1.8903)	

*: After installing in connecting rod

SERVICE DATA AND SPECIFICATIONS (SDS)

[QR25DE]

CRANKSHAFT

Unit: mm (in)

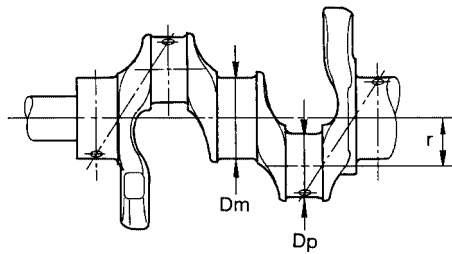

SEM645

Out-of-round (X - Y)
Taper (A - B)

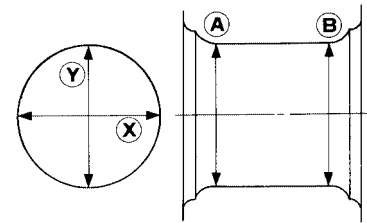

SEM715

Pin journal "DP" grade	Grade No. A	44.974 - 44.973 (1.7706 - 1.7706)	A
	Grade No. B	44.973 - 44.972 (1.7706 - 1.7705)	B
	Grade No. C	44.972 - 44.971 (1.7705 - 1.7705)	C
	Grade No. D	44.971 - 44.970 (1.7705 - 1.7705)	D
	Grade No. E	44.970 - 44.969 (1.7705 - 1.7704)	E
	Grade No. F	44.969 - 44.968 (1.7704 - 1.7704)	F
	Grade No. G	44.968 - 44.967 (1.7704 - 1.7704)	G
	Grade No. H	44.967 - 44.966 (1.7704 - 1.7703)	H
	Grade No. J	44.966 - 44.965 (1.7703 - 1.7703)	I
	Grade No. K	44.965 - 44.964 (1.7703 - 1.7702)	J
	Grade No. L	44.964 - 44.963 (1.7702 - 1.7702)	K
	Grade No. M	44.963 - 44.962 (1.7702 - 1.7702)	L
	Grade No. N	44.962 - 44.961 (1.7702 - 1.7701)	M
	Grade No. P	44.961 - 44.960 (1.7701 - 1.7701)	
Grade No. R	44.960 - 44.959 (1.7701 - 1.7700)		
Grade No. S	44.959 - 44.958 (1.7700 - 1.7700)		
Grade No. T	44.958 - 44.957 (1.7700 - 1.7700)		
Grade No. U	44.957 - 44.956 (1.7700 - 1.7699)		
Main journal "Dm" grade	Grade No. A	54.979 - 54.978 (2.1645 - 2.1645)	J
	Grade No. B	54.978 - 54.977 (2.1645 - 2.1644)	K
	Grade No. C	54.977 - 54.976 (2.1644 - 2.1644)	L
	Grade No. D	54.976 - 54.975 (2.1644 - 2.1644)	M
	Grade No. E	54.975 - 54.974 (2.1644 - 2.1643)	
	Grade No. F	54.974 - 54.973 (2.1643 - 2.1643)	
	Grade No. G	54.973 - 54.972 (2.1643 - 2.1642)	
	Grade No. H	54.972 - 54.971 (2.1642 - 2.1642)	
	Grade No. J	54.971 - 54.970 (2.1642 - 2.1642)	
	Grade No. K	54.970 - 54.969 (2.1642 - 2.1641)	
	Grade No. L	54.969 - 54.968 (2.1641 - 2.1641)	
	Grade No. M	54.968 - 54.967 (2.1641 - 2.1641)	
	Grade No. N	54.967 - 54.966 (2.1641 - 2.1640)	
	Grade No. P	54.966 - 54.965 (2.1640 - 2.1640)	
	Grade No. R	54.965 - 54.964 (2.1640 - 2.1639)	
	Grade No. S	54.964 - 54.963 (2.1639 - 2.1639)	
	Grade No. T	54.963 - 54.962 (2.1639 - 2.1639)	
Grade No. U	54.962 - 54.961 (2.1639 - 2.1638)		
Grade No. V	54.961 - 54.960 (2.1638 - 2.1638)		
Grade No. W	54.960 - 54.959 (2.1638 - 2.1637)		
Grade No. X	54.959 - 54.958 (2.1637 - 2.1637)		
Grade No. Y	54.958 - 54.957 (2.1637 - 2.1637)		
Grade No. 4	54.957 - 54.956 (2.1637 - 2.1636)		
Grade No. 7	54.956 - 54.955 (2.1636 - 2.1636)		
Center distance "r"		49.60 - 50.04 (1.9528 - 1.9701)	
Out-of-round (X - Y)	Standard	Less than 0.005 (0.0002)	
Taper (A - B)	Standard	Less than 0.005 (0.0002)	
Runout [TIR*]	Limit	Less than 0.05 (0.002)	
Free end play	Standard	0.10 - 0.26 (0.0039 - 0.0102)	
	Limit	0.30 (0.0118)	

SERVICE DATA AND SPECIFICATIONS (SDS)

[QR25DE]

*: Total indicator reading

MAIN BEARING

Unit: mm (in)

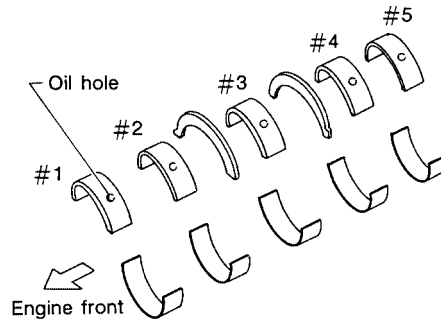

SEM685D

Grade number		Thickness	Identification color (UPR / LWR)	Remarks
0		1.973 - 1.976 (0.0777 - 0.0778)	Black	Grade and color are the same for upper and lower bearings.
1		1.976 - 1.979 (0.0778 - 0.0779)	Red	
2		1.979 - 1.982 (0.0779 - 0.0780)	Green	
3		1.982 - 1.985 (0.0780 - 0.0781)	Yellow	
4		1.985 - 1.988 (0.0781 - 0.0783)	Blue	
5		1.988 - 1.991 (0.0783 - 0.0784)	Pink	
6		1.991 - 1.994 (0.0784 - 0.0785)	Purple	
7		1.994 - 1.997 (0.0785 - 0.0786)	Orange	
01	UPR	1.973 - 1.976 (0.0777 - 0.0778)	Black / Red	Grade and color are different for upper and lower bearings.
	LWR	1.976 - 1.979 (0.0778 - 0.0779)		
12	UPR	1.976 - 1.979 (0.0778 - 0.0779)	Red / Green	
	LWR	1.979 - 1.982 (0.0779 - 0.0780)		
23	UPR	1.979 - 1.982 (0.0779 - 0.0780)	Green / Yellow	
	LWR	1.982 - 1.985 (0.0780 - 0.0781)		
34	UPR	1.982 - 1.985 (0.0780 - 0.0781)	Yellow / Blue	
	LWR	1.985 - 1.988 (0.0781 - 0.0783)		
45	UPR	1.985 - 1.988 (0.0781 - 0.0783)	Blue / Pink	
	LWR	1.988 - 1.991 (0.0783 - 0.0784)		
56	UPR	1.988 - 1.991 (0.0783 - 0.0784)	Pink / Purple	
	LWR	1.991 - 1.994 (0.0784 - 0.0785)		
67	UPR	1.991 - 1.994 (0.0784 - 0.0785)	Purple / Orange	
	LWR	1.994 - 1.997 (0.0785 - 0.0786)		

Undersize

Unit: mm (in)

Size U.S.	Thickness	Main journal diameter
0.25 (0.0098)	2.106 - 2.114 (0.0829 - 0.0832)	Grind so that bearing clearance is the specified value.

Bearing Oil Clearance

Unit: mm (in)

Main bearing oil clearance	Standard	No.1, 3, and 5	0.012 - 0.022 (0.0005 - 0.0009)
		No.2 and 4	0.018 - 0.028 (0.0007 - 0.0011)
	Limit		0.1 (0.004)

SERVICE DATA AND SPECIFICATIONS (SDS)

[QR25DE]

CONNECTING ROD BEARING

Grade number	Thickness mm (in)	Identification color (mark)
0	1.499 - 1.495 (0.0590 - 0.0589)	Black
1	1.503 - 1.499 (0.0592 - 0.0590)	Brown
2	1.507 - 1.503 (0.0593 - 0.0592)	Green
3	1.511 - 1.507 (0.0595 - 0.0593)	Yellow

Undersize

Unit: mm (in)

Size U.S.	Thickness	Crank pin journal diameter
0.25 (0.0098)	1.624 - 1.632 (0.0639 - 0.0643)	Grind so that bearing clearance is the specified value.

Bearing Oil Clearance

Unit: mm (in)

Connecting rod bearing oil clearance	Standard	0.028 - 0.045 (0.0011 - 0.0018)
	Limit	0.10 (0.0039)

Miscellaneous Components

EBS00EZ6

Unit: mm (in)

Flywheel runout [TIR*]	Less than 0.15 (0.0059)
Rotational movement 9.8 N.m (1.0 kg-m, 87 in-lb) force applied	Less than 28.3 mm (1.114 in)

*: Total indicator reading at measuring point 115 mm (4.53 in) from crankshaft center.

