

SECTION **FSU**  
FRONT SUSPENSION

A  
B  
C  
D  
E  
F  
G  
H  
I  
J  
K  
L  
M  
N  
O  
P

FSU

CONTENTS

<b>SERVICE INFORMATION</b> .....	2	Wheel Alignment Inspection .....	6	F
<b>PRECAUTIONS</b> .....	2	Component .....	9	
Precaution for Supplemental Restraint System (SRS) "AIR BAG" and "SEAT BELT PRE-TENSIONER" .....	2	Removal and Installation .....	10	
Precaution for Procedure without Cowl Top Cover.....	2	<b>COIL SPRING AND STRUT</b> .....	11	G
Cautions .....	2	Removal and Installation .....	11	
<b>PREPARATION</b> .....	3	Disassembly and Assembly .....	11	H
Special Service Tool .....	3	<b>TRANSVERSE LINK</b> .....	14	
Commercial Service Tool .....	4	Removal and Installation .....	14	
<b>NOISE, VIBRATION AND HARSHNESS (NVH) TROUBLESHOOTING</b> .....	5	<b>STABILIZER BAR</b> .....	15	I
NVH Troubleshooting Chart .....	5	Removal and Installation .....	15	
<b>FRONT SUSPENSION ASSEMBLY</b> .....	6	<b>SERVICE DATA AND SPECIFICATIONS (SDS)</b> .....	17	J
On-Vehicle Inspection and Service .....	6	Wheel Alignment (Unladen*) .....	17	
		Ball Joint .....	17	K
		Wheelarch Height (Unladen*) .....	18	

# PRECAUTIONS

< SERVICE INFORMATION >

## SERVICE INFORMATION

### PRECAUTIONS

#### Precaution for Supplemental Restraint System (SRS) "AIR BAG" and "SEAT BELT PRE-TENSIONER"

INFOID:000000001851236

The Supplemental Restraint System such as "AIR BAG" and "SEAT BELT PRE-TENSIONER", used along with a front seat belt, helps to reduce the risk or severity of injury to the driver and front passenger for certain types of collision. This system includes seat belt switch inputs and dual stage front air bag modules. The SRS system uses the seat belt switches to determine the front air bag deployment, and may only deploy one front air bag, depending on the severity of a collision and whether the front occupants are belted or unbelted. Information necessary to service the system safely is included in the SRS and SB section of this Service Manual.

#### **WARNING:**

- To avoid rendering the SRS inoperative, which could increase the risk of personal injury or death in the event of a collision which would result in air bag inflation, all maintenance must be performed by an authorized NISSAN/INFINITI dealer.
- Improper maintenance, including incorrect removal and installation of the SRS, can lead to personal injury caused by unintentional activation of the system. For removal of Spiral Cable and Air Bag Module, see the SRS section.
- Do not use electrical test equipment on any circuit related to the SRS unless instructed to in this Service Manual. SRS wiring harnesses can be identified by yellow and/or orange harnesses or harness connectors.

#### Precaution for Procedure without Cowl Top Cover

INFOID:000000001851237

When performing the procedure after removing cowl top cover, cover the lower end of windshield.

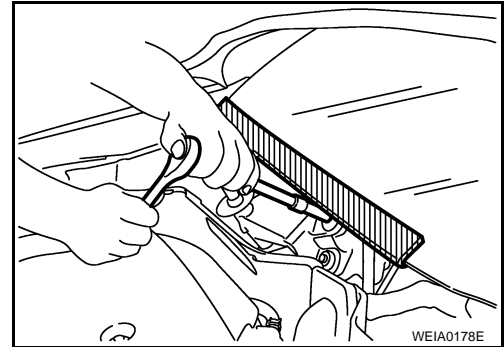

#### Cautions

INFOID:000000001851238

- When installing rubber bushings, the final tightening must be carried out under unladen conditions with tires on ground. Oil might shorten the life of rubber bushings. Be sure to wipe off any spilled oil.
- Unladen conditions mean that fuel, engine coolant and lubricant are full. Spare tire, jack, hand tools and mats are in designated positions.
- After servicing suspension parts, be sure to check wheel alignment.
- Self-lock nuts are not reusable. Always use new ones when installing.

# PREPARATION

< SERVICE INFORMATION >

## PREPARATION

### Special Service Tool

INFOID:000000001851239

The actual shapes of Kent-Moore tools may differ from those of special tools illustrated here.

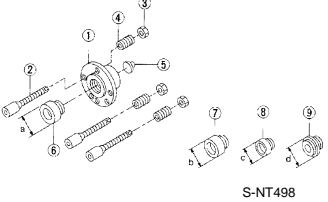
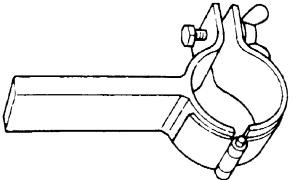
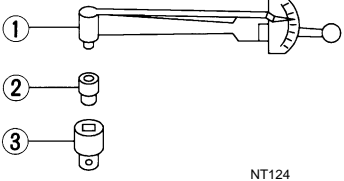
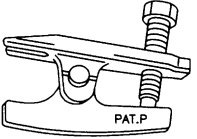
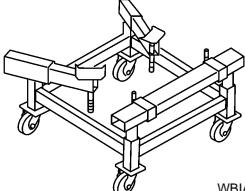
Tool number (Kent-Moore No.) Tool name	Description
KV991040S0 ( — ) CCK gauge attachment 1. Plate 2. Guide bolt 3. Nut 4. Spring 5. Center plate 6. KV99104020 Adapter A a: 72 mm (2.83 in) dia. 7. KV99104030 Adapter B b: 65 mm (2.56 in) dia. 8. KV99104040 Adapter C c: 57 mm (2.24 in) dia. 9. KV99104050 Adapter D d: 53.4 mm (2.102 in) dia.	Measuring wheel alignment 
ST35652000 ( — ) Strut attachment	Disassembling and assembling strut 
ST3127S000 (J-25742-1) Preload Gauge 1. GG91030000 (J-25765) Torque wrench 2. HT62940000 ( — ) Socket adapter (1/2") 3. HT62900000 ( — ) Socket adapter (3/8")	Measuring rotating torque of ball joint 
HT72520000 (J-25730-A) Ball joint remover	Removing tie-rod outer end and lower ball joint 
KV101J0010 (J-47242) Engine support table	Front suspension member removal 

A

B

C

D

FSU

F

G

H

I

J

K

L

M

N

O

P

# PREPARATION

< SERVICE INFORMATION >

## Commercial Service Tool

INFOID:000000001851240

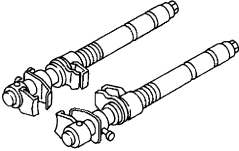
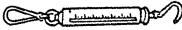
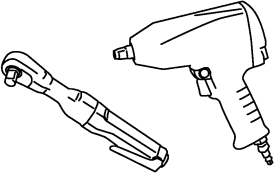
Tool name	Description
<p data-bbox="155 289 344 315">Spring compressor</p>  <p data-bbox="902 506 959 525">S-NT717</p>	<p data-bbox="1052 289 1401 315">Removing and installing coil spring</p>
<p data-bbox="155 543 289 569">Spring gauge</p>  <p data-bbox="902 758 954 777">LST025</p>	<p data-bbox="1052 543 1386 569">Inspecting tranverse link ball joint</p>
<p data-bbox="155 798 261 823">Power tool</p>  <p data-bbox="902 1010 976 1029">PBIC0190E</p>	<ul data-bbox="1052 798 1468 877" style="list-style-type: none"><li data-bbox="1052 798 1292 823">• Removing wheel nuts</li><li data-bbox="1052 827 1468 877">• Removing front suspension component parts</li></ul>

# NOISE, VIBRATION AND HARSHNESS (NVH) TROUBLESHOOTING

< SERVICE INFORMATION >

## NOISE, VIBRATION AND HARSHNESS (NVH) TROUBLESHOOTING

### NVH Troubleshooting Chart

INFOID:000000001851241

Use chart below to help you find the cause of the symptom. If necessary, repair or replace these parts.

Reference page		Possible cause and SUSPECTED PARTS														
		Improper installation, looseness	Strut deformation, damage or deflection	Bushing or mounting deterioration	Parts interference	Spring fatigue	Suspension looseness	Incorrect wheel alignment	Stabilizer bar fatigue	FRONT AXLE	FRONT SUSPENSION	TIRES	ROAD WHEEL	DRIVE SHAFT	BRAKES	STEERING
Symptom	Noise	x	x	x	x	x	x			x	x	x	x	x	x	x
	Shake	x	x	x	x		x			x	x	x	x	x	x	x
	Vibration	x	x	x	x	x				x	x	x		x		x
	Shimmy	x	x	x	x			x		x	x	x	x		x	x
	Shudder	x	x	x						x	x	x	x		x	x
	Poor quality ride or handling	x	x	x	x	x		x	x	x	x	x	x			

x: Applicable

A  
B  
C  
D  
E  
F  
G  
H  
I  
J  
K  
L  
M  
N  
O  
P

FSU

# FRONT SUSPENSION ASSEMBLY

< SERVICE INFORMATION >

## FRONT SUSPENSION ASSEMBLY

### On-Vehicle Inspection and Service

INFOID:000000001851242

Make sure the mounting conditions (looseness, back lash) of each component and component conditions (wear, damage) are normal.

#### INSPECTION OF LOWER BALL JOINT END PLAY

1. Set front wheels in a straight-ahead position. Do not depress brake pedal.
2. Place an iron bar or similar tool between transverse link and steering knuckle.
3. Measure axial end play by prying it up and down.

**Axial end play : 0 mm (0 in)**

#### **CAUTION:**

**Be careful not to damage ball joint boot. Do not damage the installation position by applying excessive force.**

#### STRUT INSPECTION

Check for oil leakage, damage and replace as necessary.

### Wheel Alignment Inspection

INFOID:000000001851243

#### PRELIMINARY INSPECTION

#### **WARNING:**

**Always adjust the alignment with the vehicle on a flat surface.**

#### **NOTE:**

If alignment is out of specification, inspect and replace any damaged or worn rear suspension parts before making any adjustments.

1. Check and adjust the wheel alignment with the vehicle under unladen conditions. "Unladen conditions" means that the fuel, coolant, and lubricant are full; and that the spare tire, jack, hand tools and mats are in their designated positions.
2. Check the tires for incorrect air pressure and excessive wear.
3. Check the wheels for run out and damage. Refer to [WT-5, "Inspection"](#).
4. Check the wheel bearing axial end play. Refer to [FAX-5, "On-Vehicle Inspection and Service"](#).
5. Check the shock absorbers for leaks or damage.
6. Check each mounting point of the suspension components for any excessive looseness or damage.
7. Check each link, arm, and the suspension member for any damage.
8. Check the vehicle height. Refer to [FSU-18, "Wheelarch Height \(Unladen\\*\)"](#).

#### GENERAL INFORMATION AND RECOMMENDATIONS

1. A Four-Wheel Thrust Alignment should be performed.
  - This type of alignment is recommended for any NISSAN vehicle.
  - The four-wheel "thrust" process helps ensure that the vehicle is properly aligned and the steering wheel is centered.
  - The alignment machine itself should be capable of accepting any NISSAN vehicle.
  - The alignment machine should be checked to ensure that it is level.
2. Make sure the alignment machine is properly calibrated.
  - Your alignment machine should be regularly calibrated in order to give correct information.
  - Check with the manufacturer of your specific alignment machine for their recommended Service/Calibration Schedule.

#### THE ALIGNMENT PROCESS

**IMPORTANT:** Use only the alignment specifications listed in this Service Manual. Refer to [FSU-17, "Wheel Alignment \(Unladen\\*\)"](#).

1. When displaying the alignment settings, many alignment machines use "indicators": (Green/red, plus or minus, Go/No Go). **Do NOT use these indicators.**
  - The alignment specifications programmed into your alignment machine that operate these indicators may not be correct.

# FRONT SUSPENSION ASSEMBLY

## < SERVICE INFORMATION >

- This may result in an ERROR.
2. Some newer alignment machines are equipped with an optional “Rolling Compensation” method to “compensate” the sensors (alignment targets or head units). **Do NOT use this “Rolling Compensation” method.**
    - Use the “Jacking Compensation” method. After installing the alignment targets or head units, raise the vehicle and rotate the wheels 1/2 turn both ways.
    - See Instructions in the alignment machine you are using for more information.

## CAMBER, CASTER AND KINGPIN INCLINATION ANGLES INSPECTION

- Camber, caster, kingpin inclination angles cannot be adjusted.
- Before inspection, mount front wheels onto turning radius gauge. Mount rear wheels onto a stand that has same height so vehicle will remain horizontal.

Using a CCK Gauge

Install the CCK gauge attachment [SST: KV991040S0] with the following procedure on wheel, then measure wheel alignment.

**Tool number : KV991040S0 ( — )**

1. Remove three wheel nuts, and install the guide bolts to hub bolt.
2. Screw the adapter into the plate until it contacts the plate tightly.
3. Screw the center plate into the plate.
4. Insert the plate assembly on the guide bolt. Put the spring in, and then evenly screw the three guide bolt nuts. When fastening the guide nuts, do not completely compress the spring.

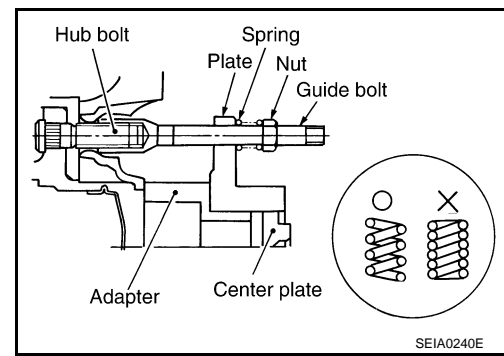

5. Place the dent of alignment gauge onto the projection of the center plate and tightly contact them to measure.

**Camber, caster, kingpin inclination angles:**

**Refer to [FSU-17, "Wheel Alignment \(Unladen\\*\)"](#).**

### **CAUTION:**

- **If camber, caster, or kingpin inclination angle is outside the specification, check front suspension parts for wear and damage. Replace suspect parts if a malfunction is detected.**
- **Kingpin inclination angle is reference value, no inspection is required.**

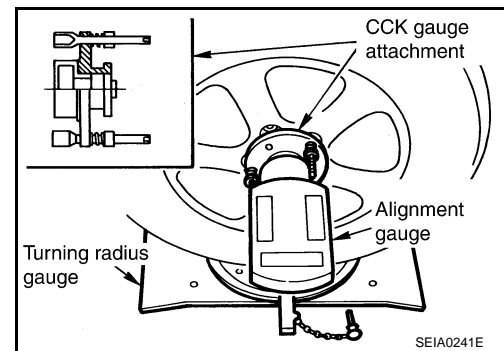

## TOE-IN INSPECTION

Measure toe-in using the following procedure.

### **WARNING:**

- **Always perform the following procedure on a flat surface.**
  - **Make sure that no person is in front of vehicle before pushing it.**
1. Bounce the front of vehicle up and down to stabilize the vehicle height (posture).
  2. Push vehicle straight ahead about 5 m (16 ft).

# FRONT SUSPENSION ASSEMBLY

## < SERVICE INFORMATION >

- Put a mark on base line of the tread (rear side) of both tires at the same height of hub center. These are measuring points.

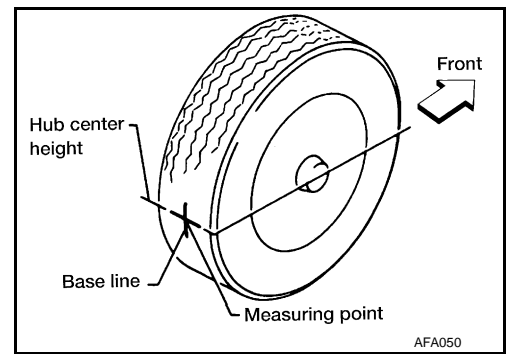

- Measure distance "A" (rear side).
- Push vehicle slowly ahead to rotate wheels 180 degrees (1/2 turn).

**CAUTION:**

**If wheels have rotated more than 180 degrees (1/2 turn), try the above procedure again from the beginning. Never push vehicle backward.**

- Measure distance "B" (front side).

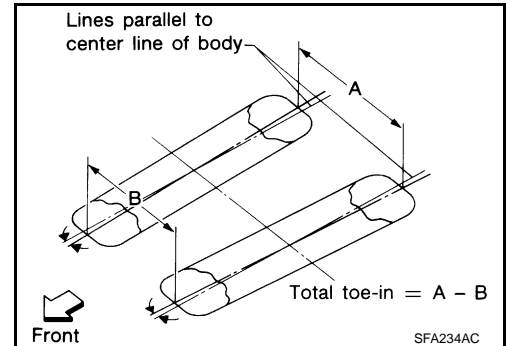

- Use the formula below to calculate total toe-in.

$$\text{Total toe-in} = A - B$$

For total toe-in specification, refer to [FSU-17, "Wheel Alignment \(Unladen\\*\)"](#).

- If the total toe-in is outside the specification, adjust toe-in by varying the length of between steering outer socket and inner socket.



# FRONT SUSPENSION ASSEMBLY

< SERVICE INFORMATION >

Component

INFOID:000000001851244

SEC. 400 • 401 • 406

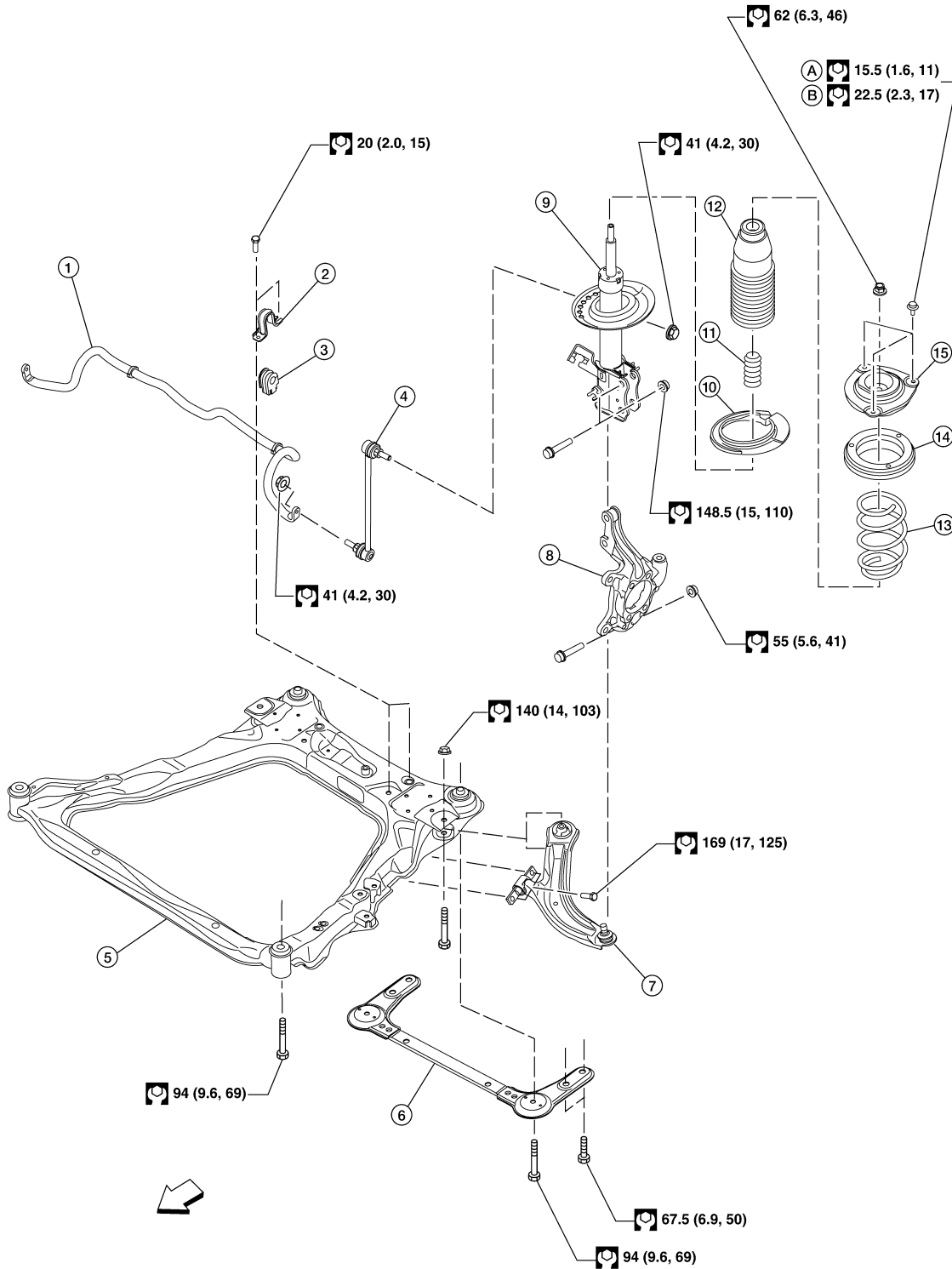

A  
B  
C  
D  
E  
F  
G  
H  
I  
J  
K  
L  
M  
N  
O  
P

FSU

- |                              |                            |                       |
|------------------------------|----------------------------|-----------------------|
| 1. Stabilizer bar            | 2. Stabilizer clamp        | 3. Stabilizer bushing |
| 4. Stabilizer connecting rod | 5. Front suspension member | 6. Member stay        |
| 7. Transverse link           | 8. Steering knuckle        | 9. Strut              |
| 10. Coil spring insulator    | 11. Bound bumper           | 12. Dust cover        |

FSU-9

AWEIA0025GB

# FRONT SUSPENSION ASSEMBLY

## < SERVICE INFORMATION >

13. Coil spring

A : SE-R models

14. Strut mounting bearing

B : Except SE-R models

15. Strut mounting insulator

⇐ : Front

Refer to [GI-7](#) for the symbols.

## Removal and Installation

INFOID:000000001851245

### REMOVAL

1. Remove front tires using power tool.
2. Separate intermediate shaft from steering gear pinion shaft. Refer to [PS-14, "Removal and Installation"](#).
3. Remove wheel sensor from steering knuckles. Refer to [BRC-31, "Removal and Installation"](#).

#### **CAUTION:**

**Do not pull on wheel sensor harness.**

4. Remove the nuts on the upper side of stabilizer connecting rods (1) with a power tool, and then remove stabilizer connecting rods (1) from strut assemblies.

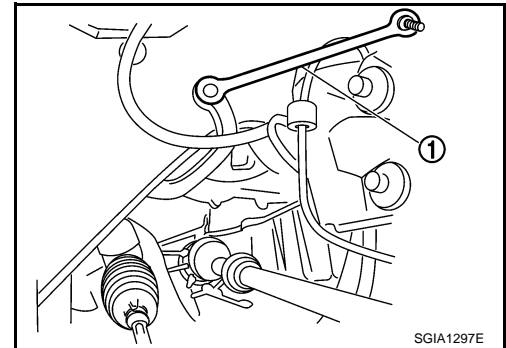

5. Loosen steering outer socket (1) nut.
6. Remove steering outer socket (1) from steering knuckle (2) so as not to damage ball joint boot (3) using Tool.

#### **CAUTION:**

**Temporarily tighten the nut to prevent damage to threads and to prevent the Tool from suddenly coming off.**

**Tool number : HT72520000 (J-25730-A)**

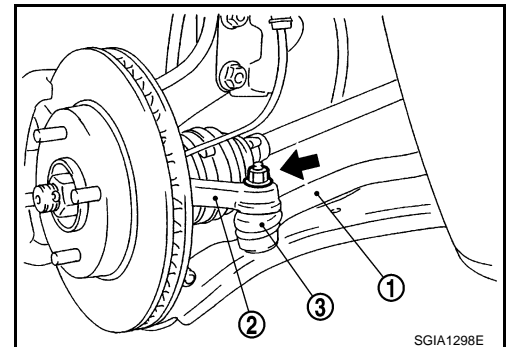

7. Remove rear torque rod. Refer to [EM-99, "Component"](#).
8. Remove A/F sensor harness bucket bolt from front suspension member assembly.
9. Remove transverse link ball joint nut and bolt from each steering knuckle. Then partially remove transverse link ball joint studs from steering knuckles.
10. Set Tool under the front suspension member, then remove the bolts from the front suspension member using power tool.

**Tool number : KV101J0010 (J-47242)**

11. Remove the bolts of member stay, and then remove member stay from vehicle.
12. Gradually lower a jack to remove front suspension assembly while ensuring transverse link ball joint studs separate from steering knuckles.

### INSTALLATION

Installation is in the reverse order of removal.

- For tightening specifications, refer to [FSU-9, "Component"](#).
- Perform final tightening of each of parts (rubber bushing), under unladen conditions, which were removed when removing front suspension assembly. Check wheel alignment. Refer to [SRS-2, "Precaution for Supplemental Restraint System \(SRS\) "AIR BAG" and "SEAT BELT PRE-TENSIONER"](#).
- Check wheel sensor harness for proper connection. Refer to [BRC-31, "Removal and Installation"](#).

# COIL SPRING AND STRUT

< SERVICE INFORMATION >

## COIL SPRING AND STRUT

### Removal and Installation

INFOID:000000001851246

#### REMOVAL

1. Remove cowl top panel. Refer to [EI-18, "Removal and Installation"](#).
2. Remove front tires using power tool.
3. Remove harness of wheel sensor from strut assembly. Refer to [BRC-31, "Removal and Installation"](#).  
**CAUTION:**  
**Do not pull on wheel sensor harness.**
4. Remove brake hose lock plate. Refer to [BR-10](#).
5. Remove the nut on the upper side of stabilizer connecting rod using power tool, and then remove stabilizer connecting rod from strut assembly.
6. Remove nuts and bolts, and then remove steering knuckle from strut assembly. Refer to [FAX-5, "Removal and Installation"](#).
7. Remove the strut mounting insulator bolts, then remove strut assembly.

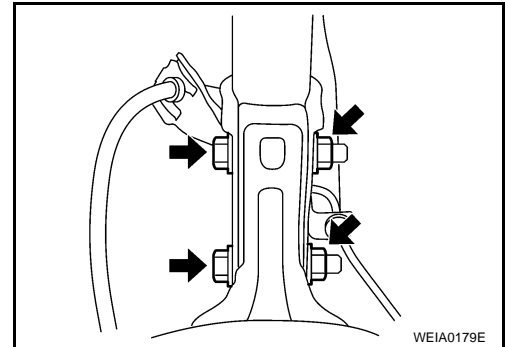

#### INSTALLATION

Installation is in the reverse order of removal.

- For tightening specifications, refer to [FSU-9, "Component"](#).
- Perform final tightening of bolts and nuts at the strut assembly lower side (rubber bushing) under unladen conditions with tires on level ground. Check wheel alignment. Refer to [SRS-2, "Precaution for Supplemental Restraint System \(SRS\) "AIR BAG" and "SEAT BELT PRE-TENSIONER" "](#).
- Check wheel sensor harness for proper connection. Refer to [BRC-31, "Removal and Installation"](#).
- Attach strut mounting insulator as shown.

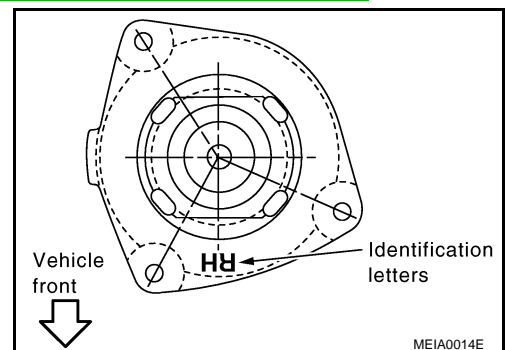

### Disassembly and Assembly

INFOID:000000001851247

#### DISASSEMBLY

- CAUTION:**  
**Do not damage strut piston rod when removing components from strut assembly.**

# COIL SPRING AND STRUT

## < SERVICE INFORMATION >

1. Install Tool (A) to strut and secure it in a vise.

**Tool number** : ST35652000 ( — )

**CAUTION:**

**When installing the Tool to strut, wrap a shop cloth around strut to protect it from damage.**

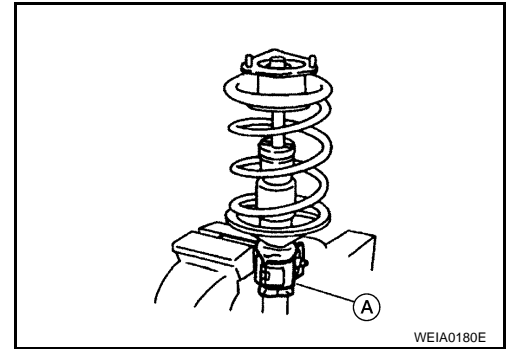

2. Using tool, compress coil spring between strut mounting bearing and spring lower seat (on strut) until coil spring is free.

**CAUTION:**

**Be sure the tool is securely attached to the coil spring before compressing coil spring.**

3. Make sure coil spring with tool between strut mounting bearing and spring lower seat (strut) is free. Then remove piston rod lock nut while securing the piston rod tip so that piston rod does not turn.
4. Remove strut mounting insulator, strut mounting bearing, coil spring with tool, dust cover, bound bumper, and coil spring insulator from strut.

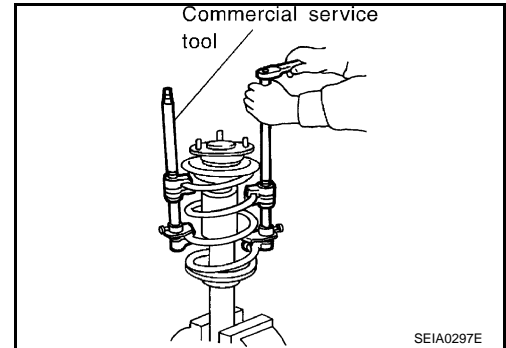

5. After removing coil spring with spring compressor, gradually release the spring compressor.

**CAUTION:**

**Loosen while making sure coil spring attachment position does not move.**

6. Remove the tool from strut.

## INSPECTION AFTER DISASSEMBLY

### Strut Inspection

Check the following:

- Strut for deformation, cracks or damage, and replace it if necessary.
- Piston rod for damage, uneven wear or distortion, and replace it if necessary.
- For oil leakage, and replace it if necessary.

### Strut Mounting Insulator and Rubber Parts Inspection

Check strut mounting insulator for cracks and rubber parts for wear. Replace it if malfunction is detected.

### Coil Spring Inspection

Check coil spring for cracks, wear or damage, and replace it if necessary.

## ASSEMBLY

**CAUTION:**

**Do not damage strut piston rod when installing components to strut.**

1. Install the Tool (A) to strut and secure it in a vise.

**Tool number** : ST35652000 ( — )

**CAUTION:**

**When installing the Tool to strut, wrap a shop cloth around strut to protect it from damage.**

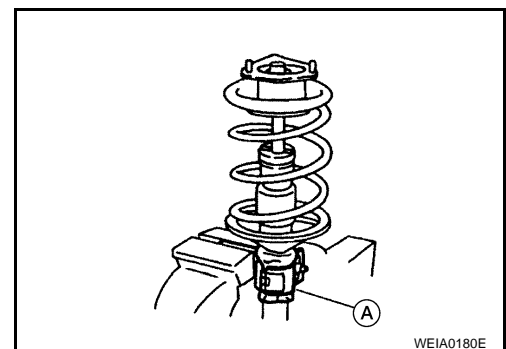

2. Install lower insulator.

## COIL SPRING AND STRUT

### < SERVICE INFORMATION >

3. Compress coil spring using tool, and install it onto strut.

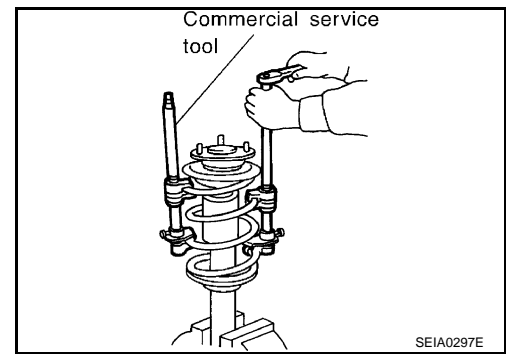

#### **CAUTION:**

- Face tube side of coil spring downward. Align the lower end to spring lower seat as shown.
- Be sure tool is securely attached to coil spring. Compress coil spring.

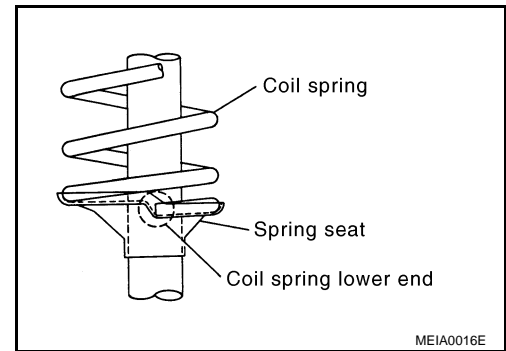

4. Install bound bumper, dust cover and upper insulator.
5. Attach strut mounting bearing and strut mounting insulator.
  - Installation position of strut mounting insulator as shown.

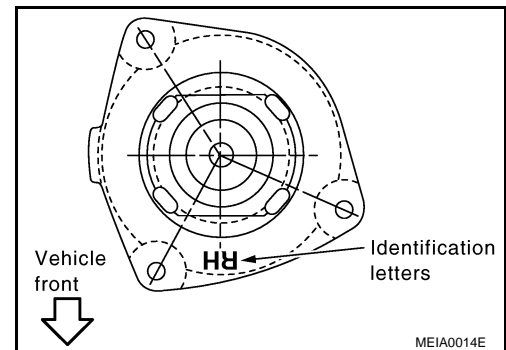

6. Secure piston rod tip so that piston rod does not turn, then tighten piston rod lock nut to specified torque.
7. Gradually release tool, and remove coil spring.

#### **CAUTION:**

**While loosening make sure tool position does not move.**

8. Remove the tool from strut.

A  
B  
C  
D  
FSU  
F  
G  
H  
I  
J  
K  
L  
M  
N  
O  
P

# TRANSVERSE LINK

< SERVICE INFORMATION >

## TRANSVERSE LINK

### Removal and Installation

INFOID:000000001851248

#### REMOVAL

1. Remove front tires from vehicle with a power tool.
2. Remove connecting rod to stabilizer bar nut. Remove connecting rod from stabilizer bar then reposition connecting rod.
3. Remove transverse link nuts and bolts, then remove transverse link from front suspension member.
4. Remove transverse link ball joint to steering knuckle nut and bolt, then remove transverse link.

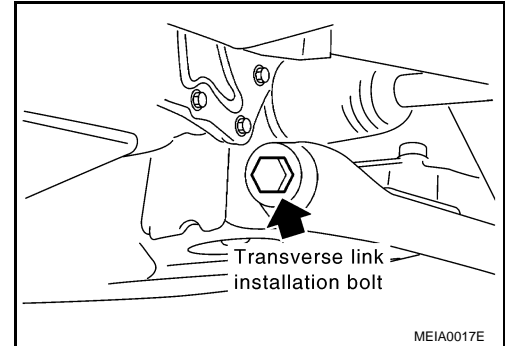

#### INSPECTION AFTER REMOVAL

##### Visual Inspection

Check the following:

- Transverse link and bushing for deformation, cracks or damage. Replace it if necessary.
- Ball joint boot for cracks or other damage, and also for grease leakage. Replace it if necessary.

##### Ball Joint Inspection

Manually move ball stud to confirm it moves smoothly with no binding.

##### Swing Torque Inspection

###### NOTE:

Before measurement, move ball stud at least ten times by hand to check for smooth movement.

- Hook a spring balance at the cutout on ball stud. Confirm spring balance measurement value is within specifications when ball stud begins moving.

##### Swing torque

: 0.5 - 4.9 N·m (0.06 - 0.49 kg-m, 5 - 43 in-lb)

##### Spring balance measurement

: 15.4 - 150.8 N (1.6 - 15.4 kg-f, 3.5 - 40 lb-f)

- If it is outside the specified range, replace transverse link assembly.

##### Axial End Play Inspection

- Move tip of ball stud in axial direction to check for looseness.

**Axial end play : 0 mm (0 in)**

- If it is outside the specified range, replace transverse link assembly.

#### INSTALLATION

Installation is in the reverse order of removal.

- For tightening specifications, refer to [FSU-9, "Component"](#).
- Perform final tightening of bolts and at the front suspension member installation position (rubber bushing) under unladen conditions with tires on level ground. Check wheel alignment. Refer to [SRS-2, "Precaution for Supplemental Restraint System \(SRS\) "AIR BAG" and "SEAT BELT PRE-TENSIONER"."](#)

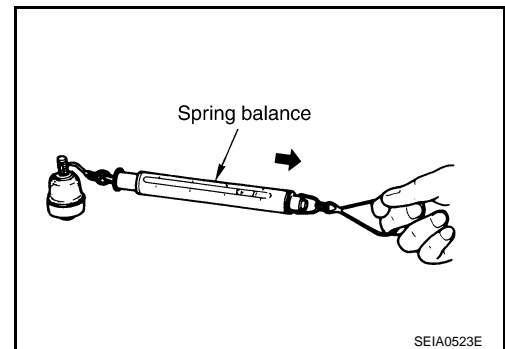

# STABILIZER BAR

< SERVICE INFORMATION >

## STABILIZER BAR

### Removal and Installation

INFOID:000000001851249

#### REMOVAL

1. Separate intermediate shaft from steering gear pinion shaft. Refer to [PS-14. "Removal and Installation"](#).
2. Remove front tires using power tool.
3. Remove the nut on the lower side of stabilizer connecting rod using power tool, and then remove stabilizer connecting rod from stabilizer bar.
4. If necessary remove stabilize connecting rod upper nut using power tool. Separate stabilizer connecting rod and strut.
5. Loosen steering outer socket (1) nut.
6. Remove steering outer socket (1) from steering knuckle (2) so as not to damage ball joint boot (3) using Tool.

**Tool number** : HT72520000 (J-25730-A)

#### CAUTION:

Temporarily tighten the nut to prevent damage to threads and to prevent the Tool from suddenly coming off.

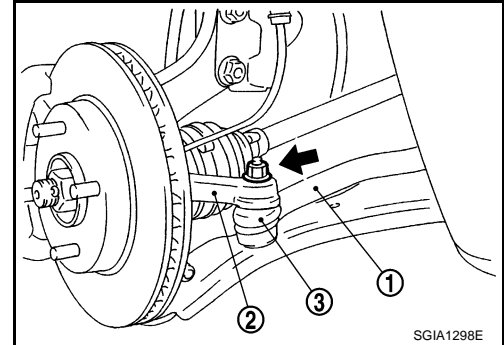

7. Remove rear torque rod. Refer to [EM-99. "Component"](#).
8. Set Tool under the front suspension member, then remove the bolts from the front suspension member using power tool.

**Tool number** : KV101J0010 (J-47242)

9. Remove the bolts of member stay using power tool, and then remove member stay.
10. Gradually lower front suspension member in order to remove stabilizer bolts.

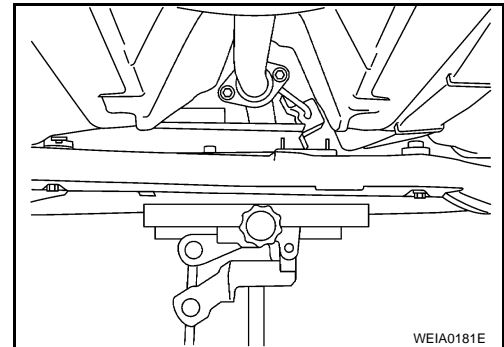

11. Remove the stabilizer clamp bolts, then remove stabilizer clamps and stabilizer bushing.
12. Remove stabilizer bar.

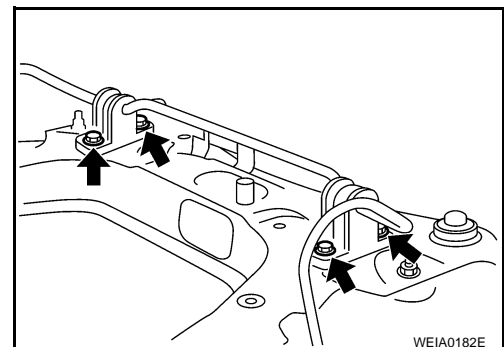

#### INSPECTION AFTER REMOVAL

Check stabilizer bar, stabilizer connecting rod, stabilizer bushing, and stabilizer clamp for deformation, cracks, and damage. Replace it if necessary.

A  
B  
C  
D  
FSU  
F  
G  
H  
I  
J  
K  
L  
M  
N  
O  
P

## STABILIZER BAR

< SERVICE INFORMATION >

---

### INSTALLATION

Installation is in the reverse order of removal.

- For tightening specifications, refer to [FSU-9, "Component"](#).



# SERVICE DATA AND SPECIFICATIONS (SDS)

< SERVICE INFORMATION >

## SERVICE DATA AND SPECIFICATIONS (SDS)

### Wheel Alignment (Unladen\*)

INFOID:000000001851250

Engine		MR20DE	QR25DE	
Model		2.0, 2.0 S, 2.0 SL	SE-R	SPEC-V
Camber Degree minute (Decimal degree)	Minimum	-0° 55' (-0.92°)	-0° 55' (-0.92°)	-1° 00' (-1.00°)
	Nominal	-0° 10' (-0.17°)	-0° 10' (-0.17°)	-0° 15' (-0.25°)
	Maximum	0° 35' (0.58°)	0° 35' (0.58°)	0° 30' (0.50°)
	Left and right difference (RH - LH)	0° 45' (0.75°) or less	0° 45' (0.75°) or less	0° 45' (0.75°) or less
Caster Degree minute (Decimal degree)	Minimum	4° 10' (4.17°)	4° 15' (4.25°)	4° 25' (4.42°)
	Nominal	4° 55' (4.92°)	5° 00' (5.00°)	5° 10' (4.17°)
	Maximum	5° 40' (5.67°)	5° 45' (5.75°)	5° 55' (5.92°)
	Left and right difference (RH - LH)	0° 45' (0.75°) or less	0° 45' (0.75°) or less	0° 45' (0.75°) or less
Kingpin inclination Degree minute (Decimal degree)		11° 05' (11.08°)	11° 05' (11.08°)	11° 20' (11.33°)

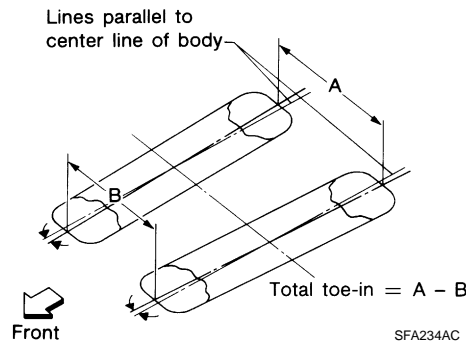

Total toe-in	Distance (A - B)	Minimum	-1 mm (-0.04 in)	-1 mm (-0.04 in)	-1 mm (-0.04 in)
		Nominal	0 mm (0.00 in)	0 mm (0.00 in)	0 mm (0.00 in)
		Maximum	1 mm (0.04 in)	1 mm (0.04 in)	1 mm (0.04 in)
	Angle (left or right, each side) Degree minute (Degree)	Minimum	-0° 02' (-0.03°)	-0° 02' (-0.03°)	-0° 02' (-0.03°)
		Nominal	0° 00' (0.00°)	0° 00' (0.00°)	0° 00' (0.00°)
		Maximum	0° 02' (0.03°)	0° 02' (0.03°)	0° 02' (0.03°)

\*: Fuel, engine coolant and engine oil full. Spare tire, jack, hand tools and mats in designated positions.

### Ball Joint

INFOID:000000001851251

Swing torque	0.5 - 4.9 N·m (0.06 - 0.49 kg-m, 5 - 43 in-lb)
Measurement on spring balance	15.4 - 150.8 N (1.6 - 15.4 kg-f, 3.5 - 40 lb-f)
Axial end play	0 mm (0 in)

# SERVICE DATA AND SPECIFICATIONS (SDS)

< SERVICE INFORMATION >

## Wheelarch Height (Unladen\*)

INFOID:000000001851252

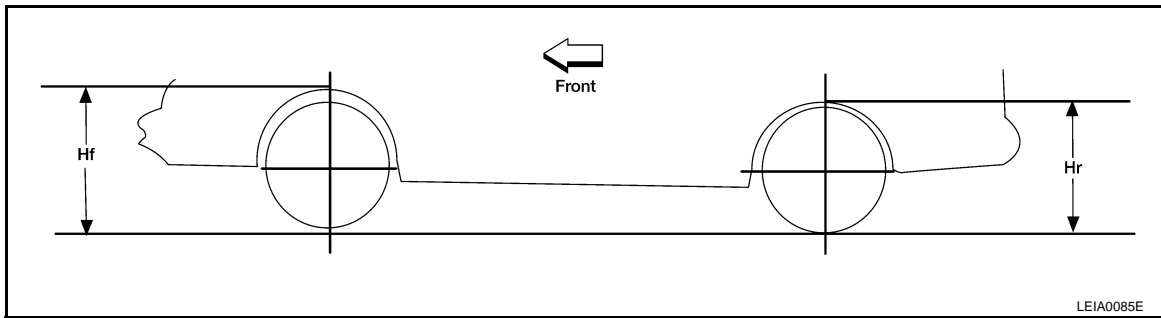

Engine	MR20DE		QR25DE	
Model	2.0	2.0 S, 2.0 SL	SE-R	SPEC-V
Tire Size	P205/60HR15	P205/55HR16	P225/45VR17	P225/45WR17
Front (Hf) mm (in)	691 (27.20)	694 (27.32)	690 (27.17)	679 (26.73)
Rear (Hr) mm (in)	693 (27.28)	696 (27.40)	690 (27.17)	677 (26.65)

\*: Fuel, radiator coolant and engine oil full. Spare tire, jack, hand tools and mats in designated positions.