

SECTION **CL**
CLUTCH

A
B
CL
D
E
F
G
H
I
J
K
L
M
N
O
P

CONTENTS

SERVICE INFORMATION	2	Inspection	9
PRECAUTIONS	2	Air Bleeding Procedure	9
Precaution for Supplemental Restraint System (SRS) "AIR BAG" and "SEAT BELT PRE-TENSIONER"	2	CLUTCH MASTER CYLINDER	11
Precaution Necessary for Steering Wheel Rotation After Battery Disconnect	2	Removal and Installation	11
Service Notice or Precaution	3	CSC (CONCENTRIC SLAVE CYLINDER)	13
PREPARATION	4	Removal and Installation	13
Special Service Tools	4	CLUTCH PIPING	14
Commercial Service Tools	4	Removal and Installation	14
NOISE, VIBRATION AND HARSHNESS (NVH) TROUBLESHOOTING	5	CLUTCH DISC, CLUTCH COVER AND FLY-WHEEL	15
NVH Troubleshooting Chart	5	Exploded View	15
CLUTCH PEDAL	6	Removal and Installation	15
On-vehicle Inspection and Adjustment	6	SERVICE DATA AND SPECIFICATIONS (SDS)	17
Removal and Installation	7	Clutch Control System	17
CLUTCH FLUID	9	Clutch Pedal	17
		Clutch Disc	17
		Clutch Cover	17

PRECAUTIONS

< SERVICE INFORMATION >

SERVICE INFORMATION

PRECAUTIONS

Precaution for Supplemental Restraint System (SRS) "AIR BAG" and "SEAT BELT PRE-TENSIONER"

INFOID:000000005612373

The Supplemental Restraint System such as "AIR BAG" and "SEAT BELT PRE-TENSIONER", used along with a front seat belt, helps to reduce the risk or severity of injury to the driver and front passenger for certain types of collision. This system includes seat belt switch inputs and dual stage front air bag modules. The SRS system uses the seat belt switches to determine the front air bag deployment, and may only deploy one front air bag, depending on the severity of a collision and whether the front occupants are belted or unbelted. Information necessary to service the system safely is included in the SRS and SB section of this Service Manual.

WARNING:

- To avoid rendering the SRS inoperative, which could increase the risk of personal injury or death in the event of a collision which would result in air bag inflation, all maintenance must be performed by an authorized NISSAN/INFINITI dealer.
- Improper maintenance, including incorrect removal and installation of the SRS can lead to personal injury caused by unintentional activation of the system. For removal of Spiral Cable and Air Bag Module, see the SRS section.
- Do not use electrical test equipment on any circuit related to the SRS unless instructed to in this Service Manual. SRS wiring harnesses can be identified by yellow and/or orange harnesses or harness connectors.

PRECAUTIONS WHEN USING POWER TOOLS (AIR OR ELECTRIC) AND HAMMERS

WARNING:

- When working near the Airbag Diagnosis Sensor Unit or other Airbag System sensors with the Ignition ON or engine running, DO NOT use air or electric power tools or strike near the sensor(s) with a hammer. Heavy vibration could activate the sensor(s) and deploy the air bag(s), possibly causing serious injury.
- When using air or electric power tools or hammers, always switch the Ignition OFF, disconnect the battery, and wait at least 3 minutes before performing any service.

Precaution Necessary for Steering Wheel Rotation After Battery Disconnect

INFOID:000000005612374

NOTE:

- This Procedure is applied only to models with Intelligent Key system and NATS (NISSAN ANTI-THEFT SYSTEM).
- Remove and install all control units after disconnecting both battery cables with the ignition knob in the "LOCK" position.
- Always use CONSULT-III to perform self-diagnosis as a part of each function inspection after finishing work. If DTC is detected, perform trouble diagnosis according to self-diagnostic results.

For models equipped with the Intelligent Key system and NATS, an electrically controlled steering lock mechanism is adopted on the key cylinder.

For this reason, if the battery is disconnected or if the battery is discharged, the steering wheel will lock and steering wheel rotation will become impossible.

If steering wheel rotation is required when battery power is interrupted, follow the procedure below before starting the repair operation.

OPERATION PROCEDURE

1. Connect both battery cables.

NOTE:

Supply power using jumper cables if battery is discharged.

2. Use the Intelligent Key or mechanical key to turn the ignition switch to the "ACC" position. At this time, the steering lock will be released.
3. Disconnect both battery cables. The steering lock will remain released and the steering wheel can be rotated.
4. Perform the necessary repair operation.

PRECAUTIONS

< SERVICE INFORMATION >

5. When the repair work is completed, return the ignition switch to the "LOCK" position before connecting the battery cables. (At this time, the steering lock mechanism will engage.)
6. Perform a self-diagnosis check of all control units using CONSULT-III.

Service Notice or Precaution

INFOID:000000005284060

- Use recommended brake fluid when adding fluid to the clutch reservoir tank. Refer to [MA-15. "MR20DE"](#) or [MA-15. "QR25DE"](#).
- Never reuse fluid drained from clutch system.
- Be careful not to splash brake fluid on painted areas.
- Use new brake fluid to clean or wash all parts of master cylinder and CSC (Concentric slave cylinder).
- Never use mineral oils such as gasoline or kerosene. It will ruin the rubber parts of the hydraulic system.
- If transaxle assembly is removed from the vehicle, always replace CSC. Return CSC to original position to remove transaxle assembly. Dust on clutch disc sliding parts may damage CSC seal and may cause clutch fluid leakage.
- Do not disassemble clutch master cylinder and CSC.

WARNING:

After cleaning clutch disc, clean it with a dust collector. Do not use compressed air.

A
B
CL
D
E
F
G
H
I
J
K
L
M
N
O
P

PREPARATION

< SERVICE INFORMATION >

PREPARATION

Special Service Tools

INFOID:000000005284061

The actual shapes of Kent-Moore tools may differ from those of special service tools illustrated here.

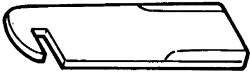
Tool number (Kent-Moore No.) Tool name	Description
ST20050240 (—) Diaphragm spring adjusting wrench  <p style="text-align: right; margin-right: 50px;">ZZA0508D</p>	Adjusting unevenness of diaphragm spring of clutch cover

Commercial Service Tools

INFOID:000000005284062

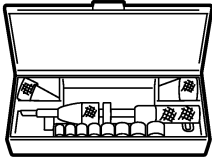
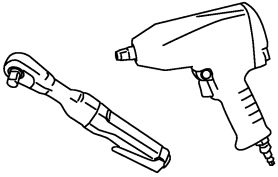
Tool name	Description
Clutch aligner  <p style="text-align: right; margin-right: 50px;">MCIB0404E</p>	Installing clutch disc
Power tool  <p style="text-align: right; margin-right: 50px;">PBIC0190E</p>	Loosening bolts and nuts

NOISE, VIBRATION AND HARSHNESS (NVH) TROUBLESHOOTING

< SERVICE INFORMATION >

NOISE, VIBRATION AND HARSHNESS (NVH) TROUBLESHOOTING

NVH Troubleshooting Chart

INFOID:000000005284063

Use the chart below to help you find the cause of the symptom. The numbers indicate the order of the inspection. If necessary, repair or replace these parts.

Symptom		SUSPECTED PARTS (Possible cause)																
		CLUTCH PEDAL (Inspection and adjustment)	CLUTCH LINE (Air in line)	ENGINE MOUNTING (Loose)	CSC (Concentric slave cylinder) (Worn, dirty or damaged)	CLUTCH DISC (Out of true)	CLUTCH DISC (Runout is excessive)	CLUTCH DISC (Lining broken)	CLUTCH DISC (Dirty or burned)	CLUTCH DISC (Oily)	CLUTCH DISC (Worn out)	CLUTCH DISC (Hardened)	CLUTCH DISC (Lack of spline grease)	DIAPHRAGM SPRING (Damaged)	DIAPHRAGM SPRING (Out of tip alignment)	PRESSURE PLATE (Distortion)	FLYWHEEL (Distortion)	
Symptom	Clutch grabs/chatters			1				2			2	2	2			2		
	Clutch pedal spongy		1															
	Clutch noisy				1													
	Clutch slips	1								2	2			3		4	5	
	Clutch does not disengage	1	2			5	5	5	5	5			5	6	6	7		
Reference page		CL-6	CL-9	EM-75 (MR20DE), EM-184 (QR25DE)	CL-13	CL-15											EM-97 (MR20DE), EM-202 (QR25DE)	

A
B
C
CL
D
E
F
G
H
I
J
K
L
M
N
O
P

CLUTCH PEDAL

< SERVICE INFORMATION >

CLUTCH PEDAL

On-vehicle Inspection and Adjustment

INFOID:000000005284064

1. Check to see if the master cylinder rod end moves freely. It should not be bound by the clutch pedal.
 - If the rod end does not move freely, remove the rod end and check for deformation or damage on the rod end. Leave the rod end removed for step 2.

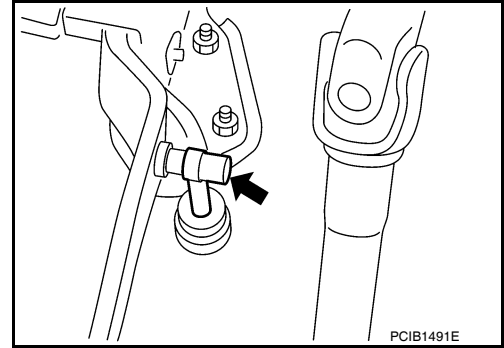

2. Check the clutch pedal stroke for free range of movement.
 - a. With the master cylinder rod end removed, manually move the pedal up and down to determine if it moves freely.
 - b. If any sticking is noted, replace the clutch pedal assembly. Re-verify that the master cylinder rod end moves freely.
3. Inspect the ASCD switch position (if equipped).
 - a. If the rod end does not move freely, check that the ASCD switch is not applying pressure to the clutch pedal causing the rod end to bind. To adjust, disconnect the ASCD switch electrical connector and turn the ASCD switch.
 - b. Connect the ASCD switch electrical connector.
4. Adjust clutch interlock switch (1) position so that clearance between clutch pedal (2) and thread end of clutch interlock switch (1), with clutch pedal fully depressed, is within specification (C).

Clearance C

Refer to [CL-17, "Clutch Pedal"](#)

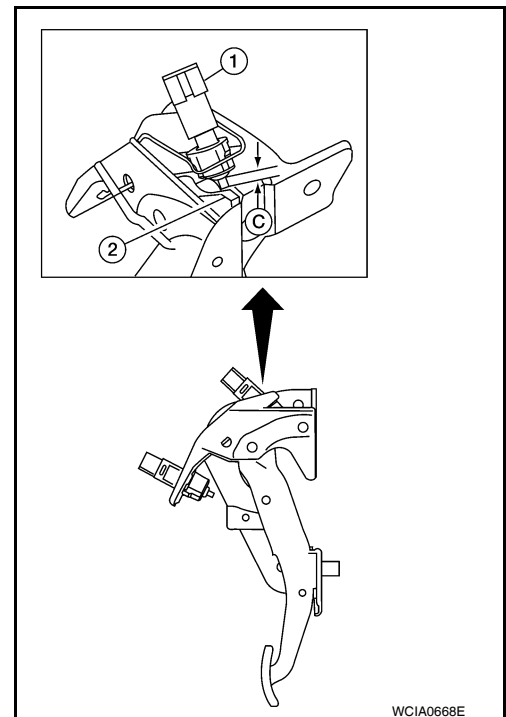

CLUTCH PEDAL

< SERVICE INFORMATION >

5. Adjust the ASCD clutch switch (1) (if equipped). Adjust ASCD clutch switch position with the clutch pedal fully released, so that clearance between clutch pedal (2) and thread end of ASCD clutch switch (1) is within specification (A).

Clearance A Refer to [CL-17, "Clutch Pedal"](#)

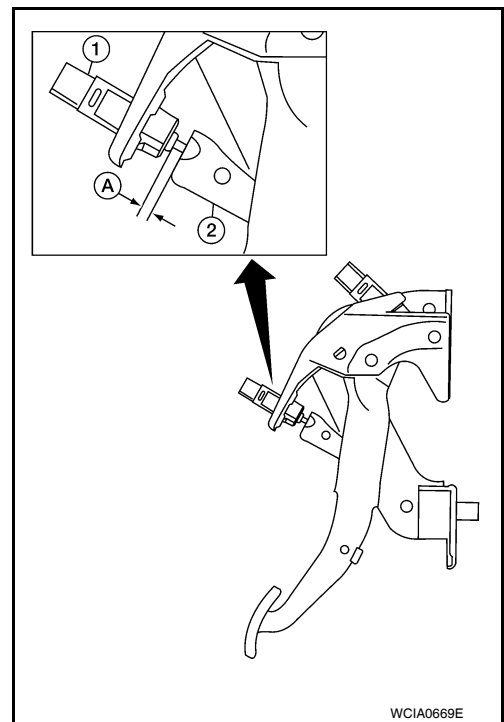

6. Check the clutch hydraulic system components (clutch master cylinder, CSC (Concentric slave cylinder), clutch damper) for sticking or binding.
 - a. If any sticking or binding is noted, repair or replace the related parts as necessary.
 - b. If any hydraulic system repair was necessary, bleed the clutch hydraulic system. Refer to [CL-9, "Air Bleeding Procedure"](#).

NOTE:

Do not use a vacuum assist or any other type of power bleeder on this system. Use of a vacuum assist or power bleeder will not purge all of the air from the system.

Removal and Installation

INFOID:000000005284065

COMPONENTS

CLUTCH PEDAL

< SERVICE INFORMATION >

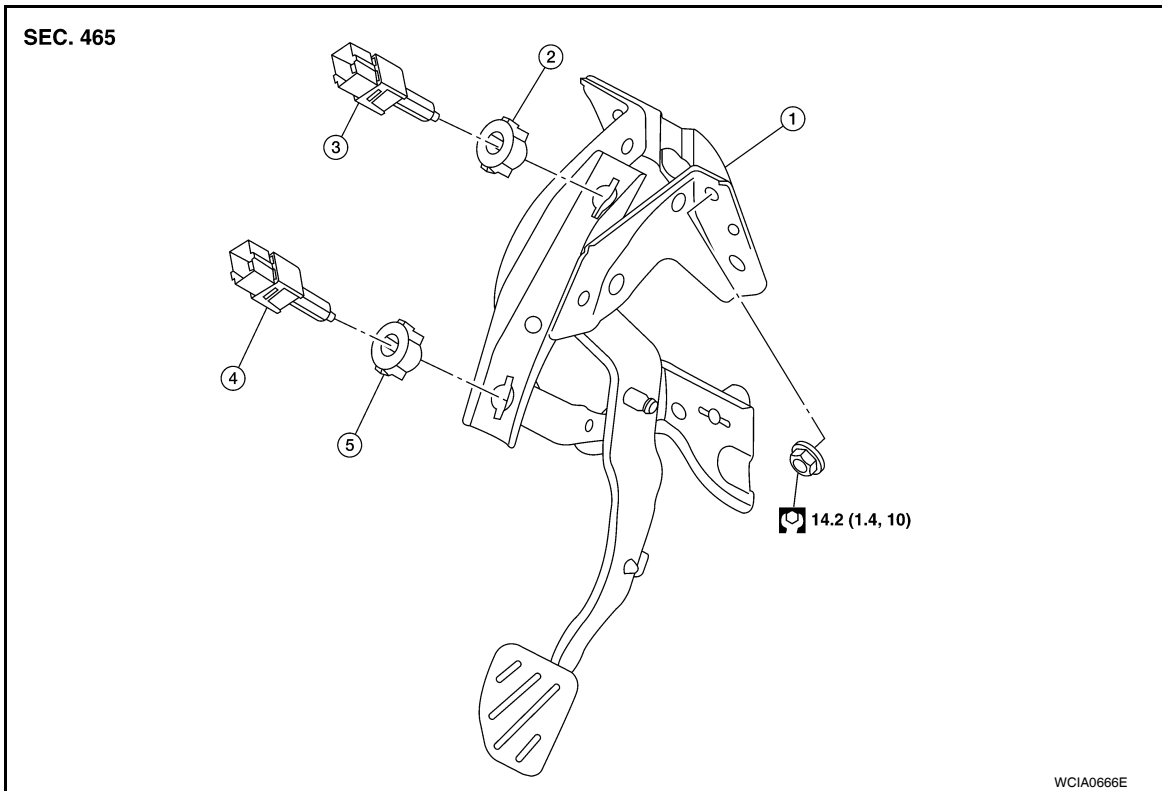

- | | | |
|-------------------------------------|-------------|----------------------------|
| 1. Clutch pedal assembly | 2. Lock nut | 3. Clutch interlock switch |
| 4. ASCD clutch switch (if equipped) | 5. Lock nut | |

REMOVAL

1. Remove instrument panel lower finisher. Refer to [IP-12, "Removal and Installation"](#).
2. Remove front upper floor duct. Refer to [MTC-77, "Removal and Installation"](#).
3. Disconnect ASCD clutch switch harness connector (if equipped).
4. Disconnect master cylinder rod end from clutch pedal lever.
5. Remove clutch pedal assembly nuts, and then remove clutch pedal assembly.
6. Disconnect clutch interlock switch harness connector.

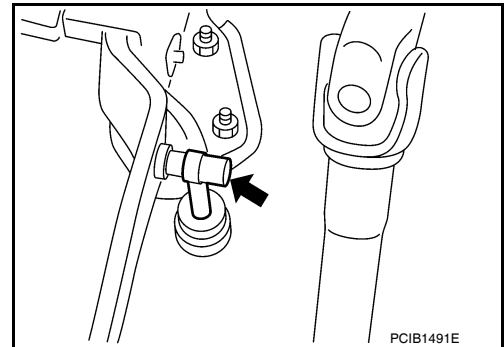

INSPECTION AFTER REMOVAL

Check clutch pedal for bend, damage or a cracked weld. If bend, damage or a cracked weld is found, replace clutch pedal assembly.

INSTALLATION

Installation is in the reverse order of removal.

- After installing the clutch switches, adjust the switch positions. Refer to [CL-6, "On-vehicle Inspection and Adjustment"](#).

CLUTCH FLUID

< SERVICE INFORMATION >

CLUTCH FLUID

Inspection

INFOID:000000005613066

FLUID LEVEL

- Check that the fluid level in the reservoir tank is within the specified range (MAX – MIN lines).
- Visually check for any clutch fluid leakage around the reservoir tank.
- Check the clutch system for any leakage if the fluid level is extremely low (lower than MIN).

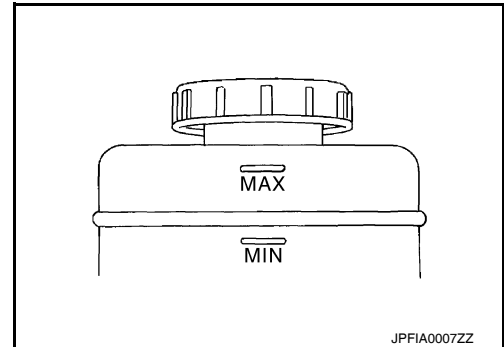

FLUID LEAKAGE

- Check clutch line for cracks, deterioration or other damage. Replace any damaged parts.
- Check for fluid leakage by fully depressing clutch pedal while engine is running.

CAUTION:

If leakage occurs around joints, reinstall the joints or, if necessary, replace damaged parts.

Air Bleeding Procedure

INFOID:000000005284066

CAUTION:

Do not spill clutch fluid onto painted surfaces. If it spills, wipe up immediately and wash the affected area with water.

NOTE:

- Do not use a vacuum assist or any other type of power bleeder on this system. Use of a vacuum assist or power bleeder will not purge all the air from the system.
- Carefully monitor fluid level in reservoir tank during bleeding operation.
- Bleed the air of bleeding connector (1).

1. Fill reservoir tank with new clutch fluid.

CAUTION:

Never reuse drained clutch fluid.

2. Connect a transparent vinyl hose to air bleeder of bleeding connector.
3. “Depress” and “release” the clutch pedal slowly and fully 15 times at an interval of 2 to 3 seconds and release the clutch pedal.

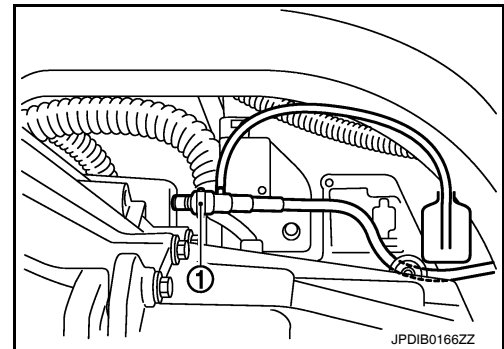

4. Press the lock pin (1) into the bleeding connector (2), and maintain the position.

CAUTION:

Since the inside of clutch tube is under hydraulic pressure, hold the tube to prevent it from getting disconnected.

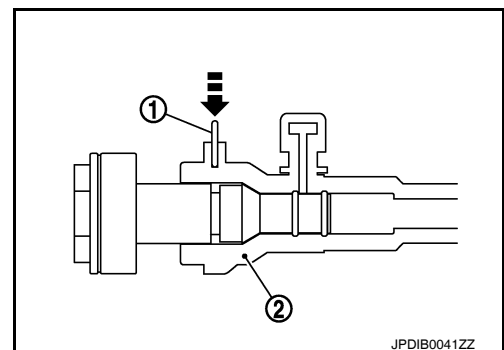

CLUTCH FLUID

< SERVICE INFORMATION >

- Slide bleeding connector (1) in the direction of the arrow as shown.

2 : Clutch housing

Dimension "A" : 10 mm (0.39 in)

- Depress the clutch pedal soon and hold it, and then bleed the air from the piping.

CAUTION:

Since the inside of clutch tube is under hydraulic pressure, hold the tube to prevent it from getting disconnected.

- Return clutch tube and lock pin in their original positions.
- Release clutch pedal and wait for 5 seconds.
- Repeat steps 3 to 8 until no bubbles are observed in the clutch fluid.
- Check that the fluid level in the reservoir tank is within the specified range after air bleeding. Refer to [CL-9. "Inspection"](#).

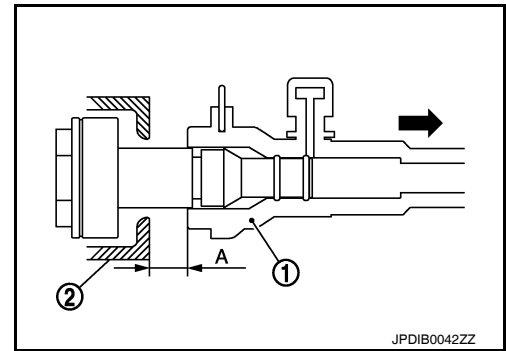

CLUTCH MASTER CYLINDER

< SERVICE INFORMATION >

CLUTCH MASTER CYLINDER

Removal and Installation

INFOID:000000005284067

REMOVAL

1. Remove the battery and battery tray. Refer to [SC-7, "Removal and Installation \(MR20DE Battery\)"](#) or [SC-9, "Removal and Installation \(QR25DE Battery Tray\)"](#).
2. Remove the engine room cover.
3. Remove the air cleaner and air duct. Refer to [EM-16, "Removal and Installation"](#) (MR20DE) or [EM-133, "Removal and Installation"](#) (QR25DE).
4. Remove engine under cover. Refer to [EI-14, "Removal and Installation"](#).
5. Use one of the following methods to remove hose from master cylinder.
 - Drain clutch fluid from reservoir tank and remove hose.
 - Remove hose from master cylinder. Immediately plug hose and reservoir tank to prevent clutch fluid from dripping.

CAUTION:

Do not spill clutch fluid onto painted surfaces. If it spills, wipe up immediately and wash the affected area with water.

6. Remove master cylinder rod end from clutch pedal assembly.

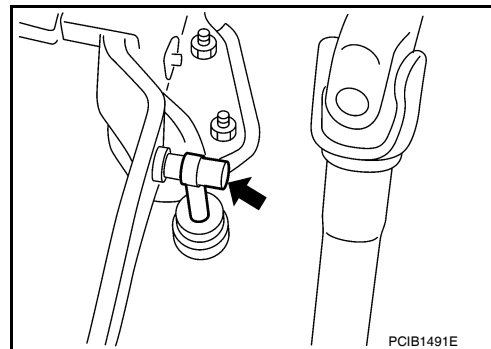

7. Remove lock pin (1) from connector of master cylinder (2) and separate clutch tube (3).

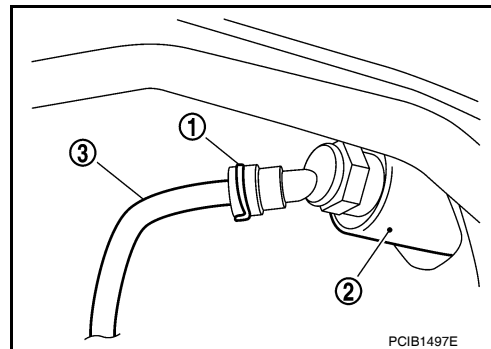

8. Rotate master cylinder clockwise by 45° and remove from the vehicle.

INSTALLATION

1. Tilt master cylinder clockwise by 45° and insert it in the mounting hole. Rotate counterclockwise to secure it. At this time, nipple is in the up position.
2. Install master cylinder rod end to clutch pedal.

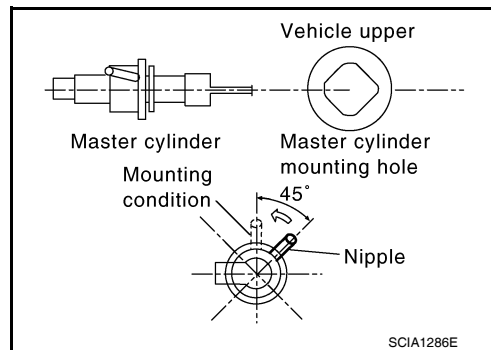

CLUTCH MASTER CYLINDER

< SERVICE INFORMATION >

3. Install clutch tube (1) fully into connector of master cylinder (2).
4. Install lock pin (3) fully into connector of master cylinder (2).
5. Fill with new clutch fluid and bleed air from the system. Refer to [CL-9, "Air Bleeding Procedure"](#).
6. After completing this procedure, inspect clutch pedal operation. Refer to [CL-6, "On-vehicle Inspection and Adjustment"](#).
7. Install the air cleaner and air duct. Refer to [EM-16, "Removal and Installation"](#) (MR20DE) or [EM-133, "Removal and Installation"](#) (QR25DE).
8. Install the battery and battery tray. Refer to [SC-7, "Removal and Installation \(MR20DE Battery\)"](#) or [SC-9, "Exploded View \(QR25DE Battery Tray\)"](#).
9. Install the engine room cover.
10. Install the engine under cover. Refer to [EI-14, "Removal and Installation"](#).

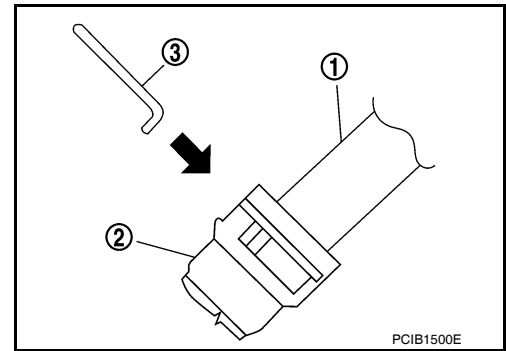

CSC (CONCENTRIC SLAVE CYLINDER)

< SERVICE INFORMATION >

CSC (CONCENTRIC SLAVE CYLINDER)

Removal and Installation

INFOID:000000005284068

COMPONENTS

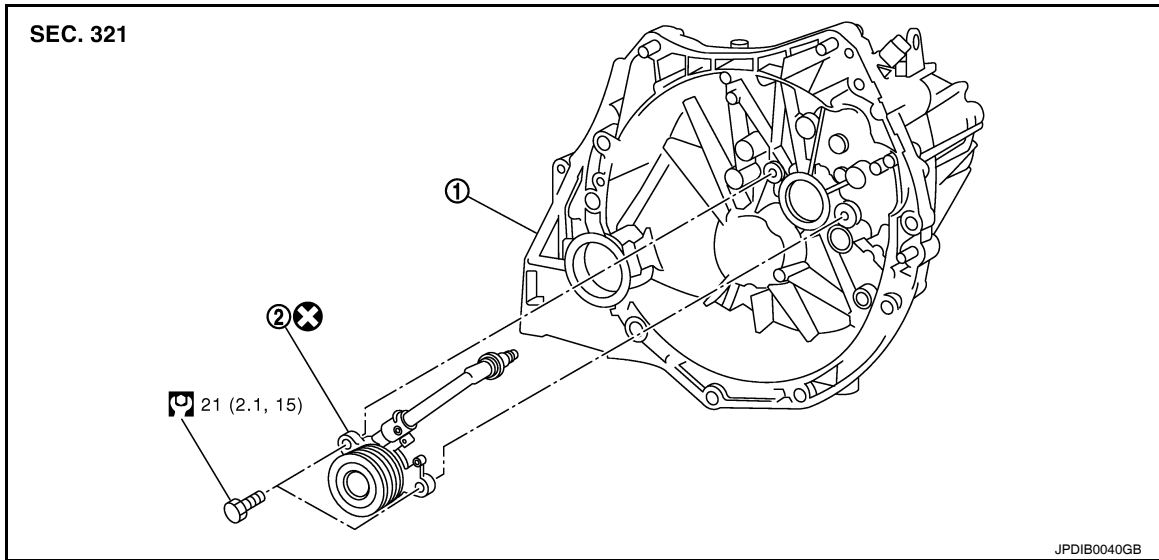

1. Transaxle assembly
2. CSC (Concentric Slave Cylinder)

CAUTION:

- If transaxle assembly is removed from the vehicle, always replace CSC (Concentric slave cylinder). Return CSC insert to original position to remove transaxle assembly. Dust on clutch disc sliding parts may damage CSC seal and may cause clutch fluid leakage.
- Do not spill clutch fluid onto painted surfaces. If it spills, wipe up immediately and wash the affected area with water.

REMOVAL

1. Remove transaxle assembly. Refer to [MT-18, "Removal and Installation"](#) (RS6F94R), [MT-68, "Removal and Installation"](#) (RS6F52A) or [MT-145, "Removal and Installation"](#) (RS6F52H).
2. Remove CSC bolts and the CSC from clutch housing.

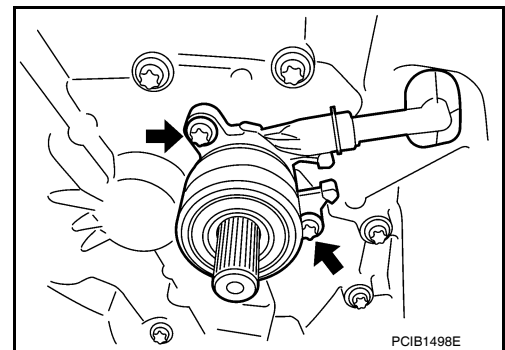

INSTALLATION

1. Install CSC to clutch housing and then tighten bolts to specification.
CAUTION:
 - Do not reuse CSC.
 - Do not insert and operate CSC because piston and stopper of CSC components may fall off.
2. Install transaxle assembly. Refer to [MT-18, "Removal and Installation"](#) (RS6F94R), [MT-68, "Removal and Installation"](#) (RS6F52A) or [MT-145, "Removal and Installation"](#) (RS6F52H).
3. Bleed the air from the clutch hydraulic system. Refer to [CL-9, "Air Bleeding Procedure"](#).

CLUTCH PIPING

< SERVICE INFORMATION >

CLUTCH PIPING

Removal and Installation

INFOID:000000005284069

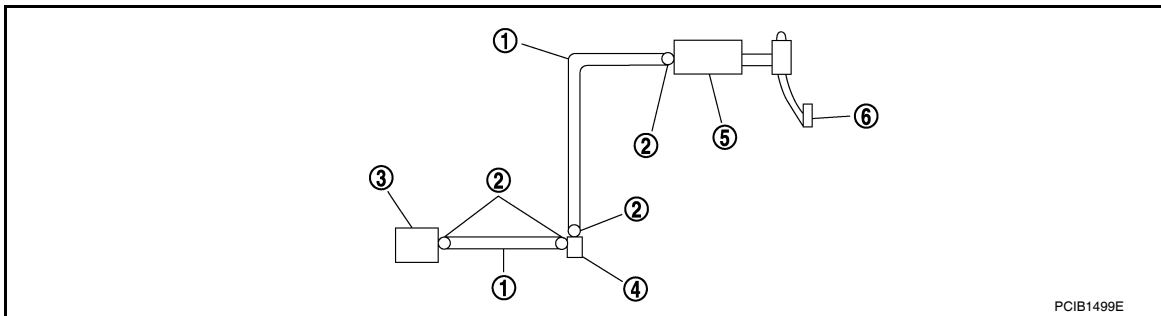

- | | | |
|------------------|---------------------------|-----------------|
| 1. Clutch tube | 2. Clutch tube lock pin | 3. CSC |
| 4. Clutch damper | 5. Clutch master cylinder | 6. Clutch pedal |

Carefully observe the following steps during clutch tube removal and installation.

CAUTION:

Do not spill clutch fluid onto painted surfaces. If it spills, wipe up immediately and wash the affected area with water.

REMOVAL

1. Remove the battery. Refer to [SC-7. "Removal and Installation \(MR20DE Battery\)"](#) or [SC-8. "Removal and Installation \(QR25DE Battery\)"](#).
2. Remove the air cleaner and air duct. Refer to [EM-16. "Removal and Installation"](#) (MR20DE) or [EM-133. "Removal and Installation"](#) (QR25DE).
3. Remove clutch tube lock pin from clutch master cylinder, if necessary.
4. Remove clutch tube lock pin at clutch housing, if necessary.
5. Remove clutch tube lock pins (2) from clutch damper (3).
6. Remove clutch tubes (1) from clutch damper (3).
7. Remove clutch damper (3) from bracket (4).

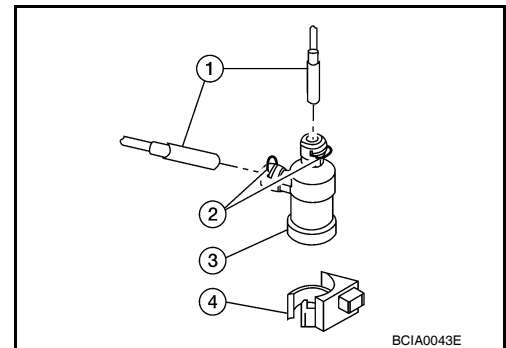

INSTALLATION

Installation is in the reverse order of removal.

- **Make sure that all tubes are fully installed into connectors.**
- **Make sure that all connector lock pins are fully installed.**
- After installation, bleed the air from the clutch hydraulic system. Refer to [CL-9. "Air Bleeding Procedure"](#).

CLUTCH DISC, CLUTCH COVER AND FLYWHEEL

< SERVICE INFORMATION >

CLUTCH DISC, CLUTCH COVER AND FLYWHEEL

Exploded View

INFOID:000000005284070

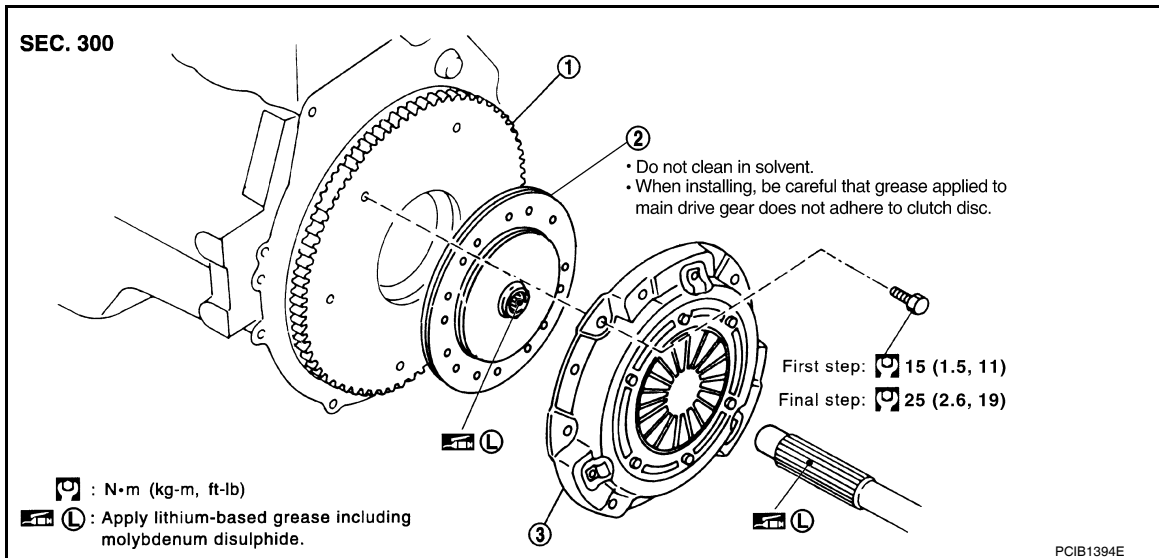

1. Flywheel

2. Clutch disc

3. Clutch cover

Removal and Installation

INFOID:000000005284071

CAUTION:

- If transaxle assembly is removed from the vehicle, always replace CSC (Concentric slave cylinder). Return CSC insert to original position to remove transaxle assembly. Dust on clutch disc sliding parts may damage CSC seal and may cause clutch fluid leakage.
- Be careful not to apply any grease to the clutch disc facing, pressure plate surface and flywheel surface.

REMOVAL

1. Remove transaxle assembly from the vehicle. Refer to [MT-18, "Removal and Installation"](#) (RS6F94R) or [MT-68, "Removal and Installation"](#) (RS6F52A), [MT-145, "Removal and Installation"](#) (RS6F52H).
2. Loosen clutch cover bolts evenly. Then remove clutch cover and clutch disc.

INSPECTION AFTER REMOVAL

Clutch Disc

- Measure circumferential runout relative to clutch disc center spline. If it is outside the specification, replace clutch disc.

Runout limit/diameter of the area to be measured : Refer to [CL-17, "Clutch Disc"](#).

- Measure backlash to clutch disc spline and main drive gear spline at the circumference of clutch disc. If it is outside the specification, replace clutch disc.

Maximum allowable spline backlash (at outer edge of disc) : Refer to [CL-17, "Clutch Disc"](#).

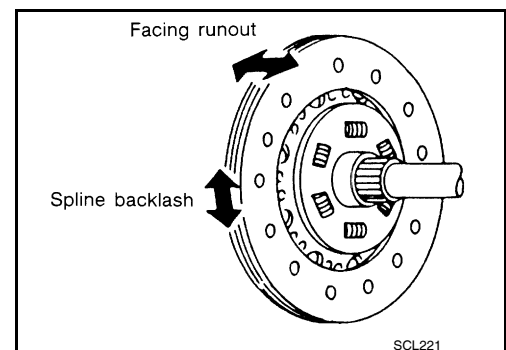

CLUTCH DISC, CLUTCH COVER AND FLYWHEEL

< SERVICE INFORMATION >

- Measure the depth "A" to clutch disc facing rivet heads, using a calipers. If it exceeds the allowable wear limit, replace clutch disc.

Facing wear limit (depth to the rivet head) "A"

: Refer to [CL-17, "Clutch Disc"](#).

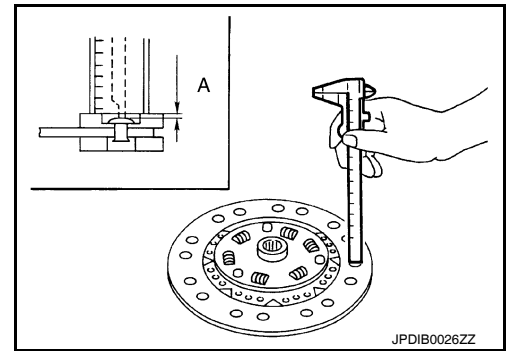

Clutch Cover

- Check clutch cover thrust ring for wear or breakage. If wear or breakage is found, replace clutch cover.

NOTE:

- Worn thrust ring will generate a beating noise when tapped at the rivet with a hammer.
- Broken thrust ring will make a clinking sound when cover is shaken up and down.
- If a trace of burn or discoloration is found on the clutch cover pressure plate to clutch disc contact surface, repair the surface with sandpaper. If surface is damaged or distorted, replace clutch cover.

INSTALLATION

1. Clean clutch disc and input shaft splines to remove grease and dust caused by abrasion.
2. Apply recommended grease to clutch disc and input shaft splines.

CAUTION:

Be sure to apply grease to the points specified. Otherwise, noise, poor disengagement, or damage to the clutch may result. Excessive grease may cause slip or shudder. If it adheres to CSC seal, it will cause clutch fluid leakage. Wipe off excess grease.

3. Install clutch disc, using a clutch aligner (A) [Commercial service tool].
4. Install clutch cover and then temporarily tighten clutch cover mounting bolts.
5. Tighten clutch cover mounting bolts to the specified torque evenly in two steps in the numerical order as shown.
6. Install transaxle assembly. Refer to [MT-18, "Removal and Installation"](#) (RS6F94R), [MT-68, "Removal and Installation"](#) (RS6F52A) or [MT-145, "Removal and Installation"](#) (RS6F52H).

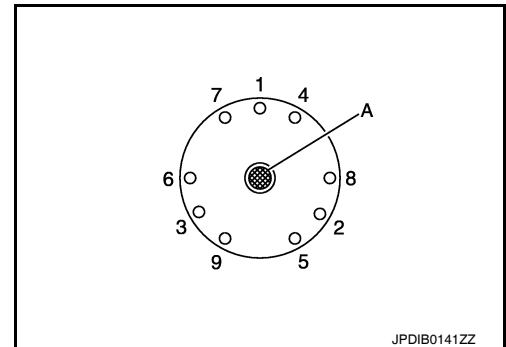

INSPECTION AFTER INSTALLATION

Clutch Cover

Check diaphragm spring lever claws for unevenness with the lever still on the vehicle. If they exceed the tolerance, adjust lever height, using the diaphragm adjusting wrench (A) [SST: ST20050240 (-)].

Tolerance for diaphragm spring lever unevenness

: Refer to [CL-17, "Clutch Cover"](#).

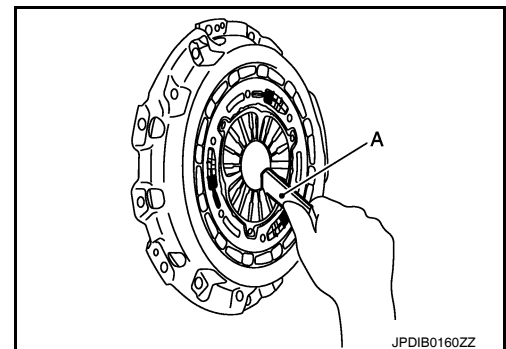

SERVICE DATA AND SPECIFICATIONS (SDS)

< SERVICE INFORMATION >

SERVICE DATA AND SPECIFICATIONS (SDS)

Clutch Control System

INFOID:000000005284072

Type of clutch control	Hydraulic
------------------------	-----------

Clutch Pedal

INFOID:000000005284073

Clearance "A" between clutch pedal and ASCD switch threaded end while clutch pedal is fully released (if equipped).	0.74 - 1.96 mm (0.0291 - 0.0772 in)
Clearance "C" between clutch pedal and clutch interlock switch threaded end while clutch pedal is fully depressed.	0.74 - 1.96 mm (0.0291 - 0.0772 in)

Clutch Disc

INFOID:000000005284074

Engine	MR20DE	QR25DE
Model	225	240
Facing size (outer dia. × inner dia. × thickness)	225 mm × 160 mm × 3.2 mm (8.86 in × 6.30 in × 0.126 in)	240 mm × 160 mm × 3.2 mm (9.45 in × 6.30 in × 0.126 in)
Runout limit/diameter of the area to be measured	1.0 mm (0.039 in) / 215 mm (8.46 in) dia.	0.7 mm (0.028 in) / 230 mm (9.06 in) dia.
Maximum allowable spline backlash (at outer edge of disc)	1.0 mm (0.039 in)	
Facing wear limit (depth to the rivet head) (A)	0.3 mm (0.012 in)	

Clutch Cover

INFOID:000000005284075

Engine	MR20DE	QR25DE
Tolerance for diaphragm spring lever unevenness	0.7 mm (0.028 in) or less	