

A

ACC

SECTION ACC

ACCELERATOR CONTROL SYSTEM

C

CONTENTS

D

E

SERVICE INFORMATION 2	ACCELERATOR CONTROL SYSTEM 4	F
PRECAUTIONS 2	Component 4	
Precaution for Supplemental Restraint System (SRS) "AIR BAG" and "SEAT BELT PRE-TENSIONER" 2	Removal and Installation 4	G
Precaution Necessary for Steering Wheel Rotation After Battery Disconnect 2	SERVICE DATA AND SPECIFICATIONS (SDS) 5	
	Accelerator Control 5	H

I

J

K

L

M

N

O

P

PRECAUTIONS

< SERVICE INFORMATION >

SERVICE INFORMATION

PRECAUTIONS

Precaution for Supplemental Restraint System (SRS) "AIR BAG" and "SEAT BELT PRE-TENSIONER"

INFOID:000000006152120

The Supplemental Restraint System such as "AIR BAG" and "SEAT BELT PRE-TENSIONER", used along with a front seat belt, helps to reduce the risk or severity of injury to the driver and front passenger for certain types of collision. This system includes seat belt switch inputs and dual stage front air bag modules. The SRS system uses the seat belt switches to determine the front air bag deployment, and may only deploy one front air bag, depending on the severity of a collision and whether the front occupants are belted or unbelted. Information necessary to service the system safely is included in the SRS and SB section of this Service Manual.

WARNING:

- To avoid rendering the SRS inoperative, which could increase the risk of personal injury or death in the event of a collision which would result in air bag inflation, all maintenance must be performed by an authorized NISSAN/INFINITI dealer.
- Improper maintenance, including incorrect removal and installation of the SRS can lead to personal injury caused by unintentional activation of the system. For removal of Spiral Cable and Air Bag Module, see the SRS section.
- Do not use electrical test equipment on any circuit related to the SRS unless instructed to in this Service Manual. SRS wiring harnesses can be identified by yellow and/or orange harnesses or harness connectors.

PRECAUTIONS WHEN USING POWER TOOLS (AIR OR ELECTRIC) AND HAMMERS

WARNING:

- When working near the Airbag Diagnosis Sensor Unit or other Airbag System sensors with the Ignition ON or engine running, DO NOT use air or electric power tools or strike near the sensor(s) with a hammer. Heavy vibration could activate the sensor(s) and deploy the air bag(s), possibly causing serious injury.
- When using air or electric power tools or hammers, always switch the Ignition OFF, disconnect the battery, and wait at least 3 minutes before performing any service.

Precaution Necessary for Steering Wheel Rotation After Battery Disconnect

INFOID:000000006152121

NOTE:

- This Procedure is applied only to models with Intelligent Key system and NATS (NISSAN ANTI-THEFT SYSTEM).
- Remove and install all control units after disconnecting both battery cables with the ignition knob in the "LOCK" position.
- Always use CONSULT-III to perform self-diagnosis as a part of each function inspection after finishing work. If DTC is detected, perform trouble diagnosis according to self-diagnostic results.

For models equipped with the Intelligent Key system and NATS, an electrically controlled steering lock mechanism is adopted on the key cylinder.

For this reason, if the battery is disconnected or if the battery is discharged, the steering wheel will lock and steering wheel rotation will become impossible.

If steering wheel rotation is required when battery power is interrupted, follow the procedure below before starting the repair operation.

OPERATION PROCEDURE

1. Connect both battery cables.

NOTE:

Supply power using jumper cables if battery is discharged.

2. Use the Intelligent Key or mechanical key to turn the ignition switch to the "ACC" position. At this time, the steering lock will be released.
3. Disconnect both battery cables. The steering lock will remain released and the steering wheel can be rotated.
4. Perform the necessary repair operation.

PRECAUTIONS

< SERVICE INFORMATION >

5. When the repair work is completed, return the ignition switch to the "LOCK" position before connecting the battery cables. (At this time, the steering lock mechanism will engage.)
6. Perform a self-diagnosis check of all control units using CONSULT-III.

A

ACC

C

D

E

F

G

H

I

J

K

L

M

N

O

P

ACCELERATOR CONTROL SYSTEM

< SERVICE INFORMATION >

ACCELERATOR CONTROL SYSTEM

Component

INFOID:000000006152122

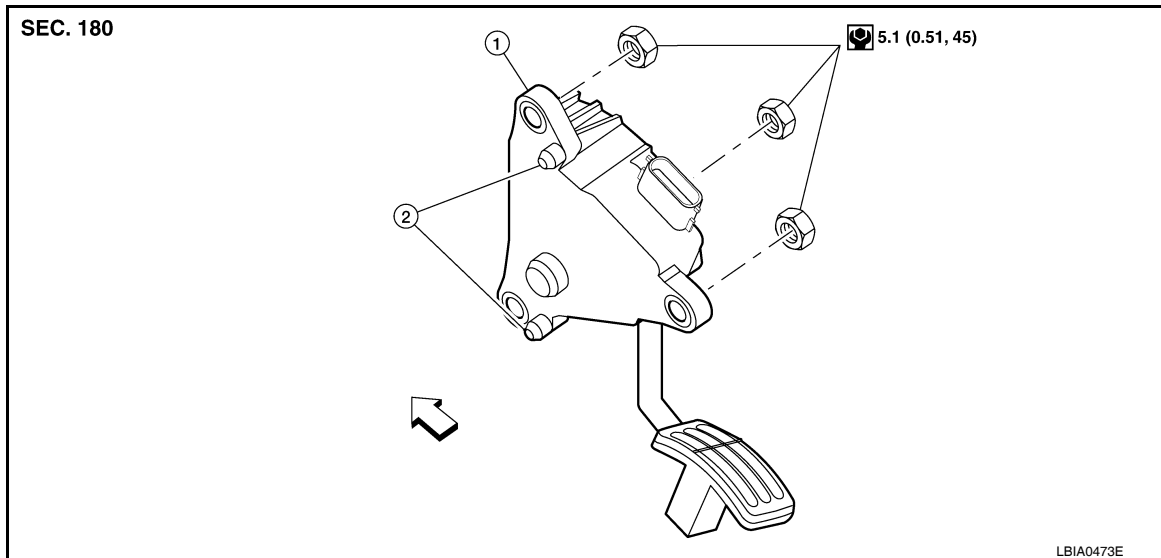

1. Accelerator pedal assembly

2. Locating pins

← Vehicle front

Removal and Installation

INFOID:000000006152123

CAUTION:

- Do not disassemble accelerator pedal assembly. Do not remove accelerator pedal position sensor from accelerator pedal assembly.
- Avoid impact from dropping etc. during handling.
- Be careful to keep accelerator pedal assembly away from water.

REMOVAL

1. Disconnect the negative battery terminal.
2. Disconnect accelerator pedal position sensor harness connector.
3. Remove the accelerator pedal assembly nuts and remove accelerator pedal assembly.

INSTALLATION

Installation is in the reverse order of removal.

- Check the accelerator pedal for smooth operation. There should be no binding or sticking when applying or releasing the accelerator pedal.
- Check that the accelerator pedal moves through the full specified distance of the specified pedal travel (A).

Pedal Travel (A) : 50.5 mm (1.99 in)

CAUTION:

- When the accelerator pedal position sensor harness connector is disconnected, perform the "Accelerator Pedal Released Position Learning". Refer to [EC-98, "Accelerator Pedal Released Position Learning"](#) (MR20DE For California), [EC-648, "Accelerator Pedal Released Position Learning"](#) (MR20DE Except For California), [EC-1183, "Accelerator Pedal Released Position Learning"](#) (QR25DE).

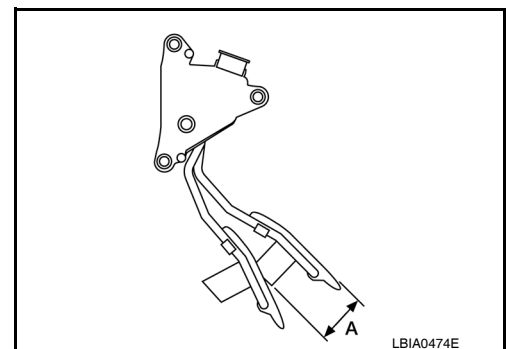

SERVICE DATA AND SPECIFICATIONS (SDS)

< SERVICE INFORMATION >

SERVICE DATA AND SPECIFICATIONS (SDS)

Accelerator Control

INFOID:000000006152124

PEDAL TRAVEL

A

ACC

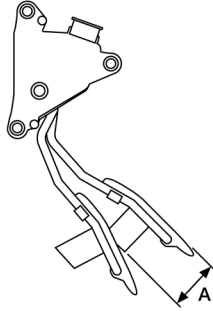

C

D

E

LBIA0474E

Accelerator pedal - total travel (A)

50.5 mm (1.99 in)

F

G

H

I

J

K

L

M

N

O

P