

A  
LU  
C  
D  
E  
F  
G  
H  
I  
J  
K  
L  
M  
N  
O  
P

# SECTION LU

## ENGINE LUBRICATION SYSTEM

### CONTENTS

<b>MR20DE</b>	
<b>SERVICE INFORMATION</b> .....	Precaution for Supplemental Restraint System (SRS) "AIR BAG" and "SEAT BELT PRE-TENSIONER" .....
2	12
<b>PRECAUTIONS</b> .....	Precaution Necessary for Steering Wheel Rotation After Battery Disconnect .....
2	12
Precaution for Supplemental Restraint System (SRS) "AIR BAG" and "SEAT BELT PRE-TENSIONER" .....	
2	
Precaution Necessary for Steering Wheel Rotation After Battery Disconnect .....	
2	
<b>PREPARATION</b> .....	<b>PREPARATION</b> .....
4	14
Special Service Tool .....	Special Service Tool .....
4	14
Commercial Service Tool .....	Commercial Service Tool .....
4	14
<b>LUBRICATION SYSTEM</b> .....	<b>LUBRICATION SYSTEM</b> .....
5	16
Lubrication Circuit .....	Lubrication Circuit .....
5	16
Schematic .....	Schematic .....
16	16
<b>ENGINE OIL</b> .....	<b>ENGINE OIL</b> .....
6	18
Inspection .....	Inspection .....
6	18
Changing Engine Oil .....	Changing Engine Oil .....
7	19
<b>OIL FILTER</b> .....	<b>OIL FILTER</b> .....
9	20
Removal and Installation .....	Removal and Installation .....
9	20
<b>SERVICE DATA AND SPECIFICATIONS (SDS)</b> .....	<b>OIL PUMP</b> .....
11	22
Oil Pressure .....	Removal and Installation .....
11	22
Oil Capacity .....	Disassembly and Assembly .....
11	22
<b>QR25DE</b>	<b>OIL COOLER</b> .....
<b>SERVICE INFORMATION</b> .....	25
12	Removal and Installation .....
<b>PRECAUTIONS</b> .....	25
12	<b>SERVICE DATA AND SPECIFICATIONS (SDS)</b> .....
	27
	Oil Pressure .....
	27
	Oil Pump .....
	27
	Regulator Valve .....
	27
	Oil Capacity .....
	27

## SERVICE INFORMATION

### PRECAUTIONS

#### Precaution for Supplemental Restraint System (SRS) "AIR BAG" and "SEAT BELT PRE-TENSIONER"

INFOID:000000006152150

The Supplemental Restraint System such as "AIR BAG" and "SEAT BELT PRE-TENSIONER", used along with a front seat belt, helps to reduce the risk or severity of injury to the driver and front passenger for certain types of collision. This system includes seat belt switch inputs and dual stage front air bag modules. The SRS system uses the seat belt switches to determine the front air bag deployment, and may only deploy one front air bag, depending on the severity of a collision and whether the front occupants are belted or unbelted. Information necessary to service the system safely is included in the SRS and SB section of this Service Manual.

#### **WARNING:**

- To avoid rendering the SRS inoperative, which could increase the risk of personal injury or death in the event of a collision which would result in air bag inflation, all maintenance must be performed by an authorized NISSAN/INFINITI dealer.
- Improper maintenance, including incorrect removal and installation of the SRS can lead to personal injury caused by unintentional activation of the system. For removal of Spiral Cable and Air Bag Module, see the SRS section.
- Do not use electrical test equipment on any circuit related to the SRS unless instructed to in this Service Manual. SRS wiring harnesses can be identified by yellow and/or orange harnesses or harness connectors.

#### PRECAUTIONS WHEN USING POWER TOOLS (AIR OR ELECTRIC) AND HAMMERS

#### **WARNING:**

- When working near the Airbag Diagnosis Sensor Unit or other Airbag System sensors with the Ignition ON or engine running, DO NOT use air or electric power tools or strike near the sensor(s) with a hammer. Heavy vibration could activate the sensor(s) and deploy the air bag(s), possibly causing serious injury.
- When using air or electric power tools or hammers, always switch the Ignition OFF, disconnect the battery, and wait at least 3 minutes before performing any service.

#### Precaution Necessary for Steering Wheel Rotation After Battery Disconnect

INFOID:000000006152151

#### **NOTE:**

- This Procedure is applied only to models with Intelligent Key system and NATS (NISSAN ANTI-THEFT SYSTEM).
- Remove and install all control units after disconnecting both battery cables with the ignition knob in the "LOCK" position.
- Always use CONSULT-III to perform self-diagnosis as a part of each function inspection after finishing work. If DTC is detected, perform trouble diagnosis according to self-diagnostic results.

For models equipped with the Intelligent Key system and NATS, an electrically controlled steering lock mechanism is adopted on the key cylinder.

For this reason, if the battery is disconnected or if the battery is discharged, the steering wheel will lock and steering wheel rotation will become impossible.

If steering wheel rotation is required when battery power is interrupted, follow the procedure below before starting the repair operation.

#### OPERATION PROCEDURE

1. Connect both battery cables.

#### **NOTE:**

Supply power using jumper cables if battery is discharged.

2. Use the Intelligent Key or mechanical key to turn the ignition switch to the "ACC" position. At this time, the steering lock will be released.
3. Disconnect both battery cables. The steering lock will remain released and the steering wheel can be rotated.
4. Perform the necessary repair operation.

# PRECAUTIONS

< SERVICE INFORMATION >

[MR20DE]

5. When the repair work is completed, return the ignition switch to the "LOCK" position before connecting the battery cables. (At this time, the steering lock mechanism will engage.)
6. Perform a self-diagnosis check of all control units using CONSULT-III.

A

**LU**

C

D

E

F

G

H

I

J

K

L

M

N

O

P

# PREPARATION

< SERVICE INFORMATION >

[MR20DE]

## PREPARATION

### Special Service Tool

INFOID:000000006152152

The actual shapes of Kent-Moore tools may differ from those of special service tools illustrated here.

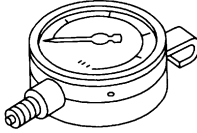
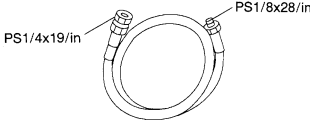
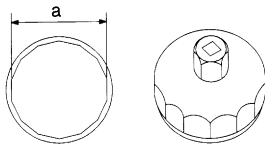
Tool number (Kent-Moore No.) Tool name	Description
ST25051001 (J-25695-1) Oil pressure gauge   NT050	Measuring oil pressure <b>Maximum measuring range: 2,452 kPa (25 kg/cm<sup>2</sup>, 356 psi)</b>
ST25052000 (J-25695-2) Hose   S-NT559	Adapting oil pressure gauge to oil pan (upper)
KV10115801 (J-38956) Oil filter wrench   S-NT375	Removing oil filter <b>a: 64.3 mm (2.531 in)</b>

### Commercial Service Tool

INFOID:000000006152153

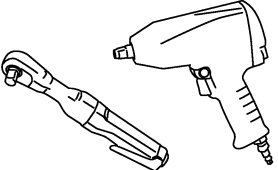
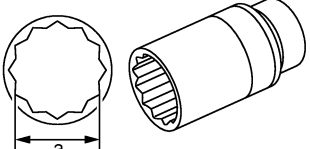
Tool name	Description
Power tool   PBIC0190E	Loosening nuts and bolts
Deep socket   PBIC2072E	Removing and installing oil pressure switch <b>a: 26 mm (1.02 in)</b>

# LUBRICATION SYSTEM

< SERVICE INFORMATION >

[MR20DE]

## LUBRICATION SYSTEM

### Lubrication Circuit

INFOID:000000006152154

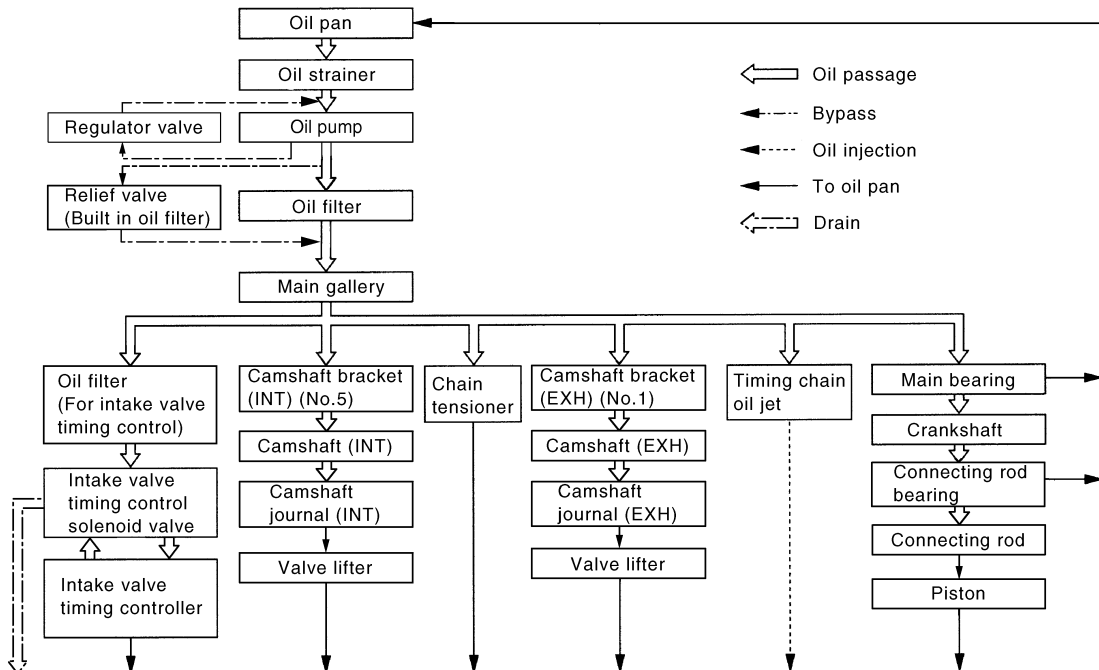
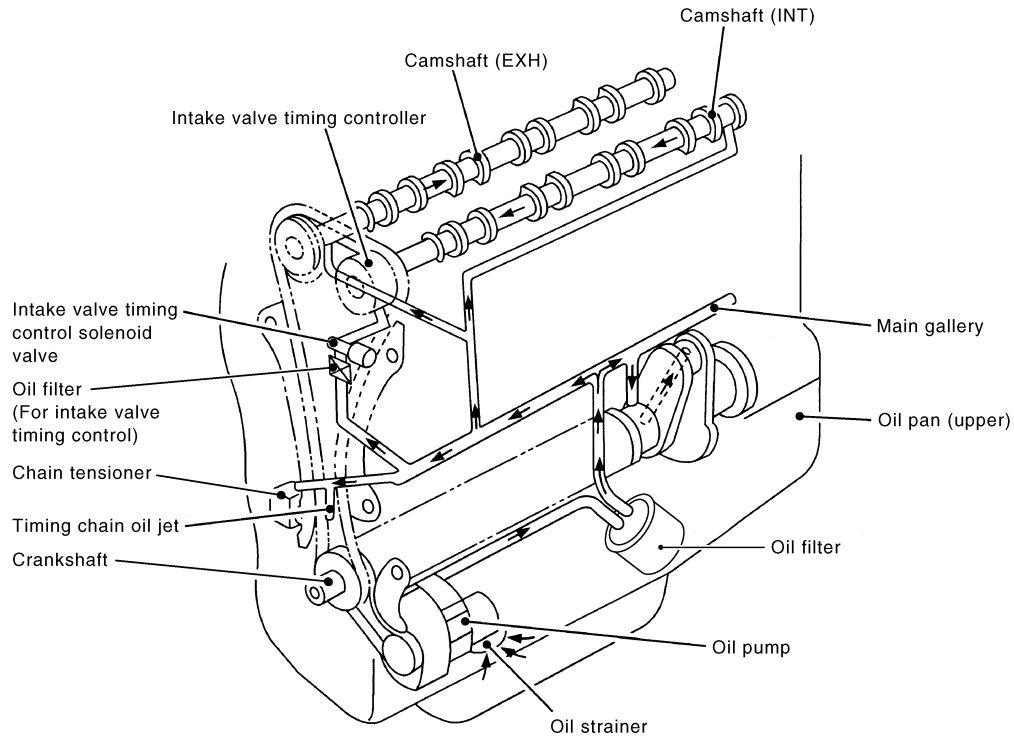

PBIC4575E

## ENGINE OIL

### Inspection

INFOID:000000006152155

#### ENGINE OIL LEVEL

**NOTE:**

Before starting engine, park vehicle on a level surface and check the engine oil level. If engine is already started, stop it and allow 10 minutes before checking.

1. Pull out oil level gauge and wipe it clean.
2. Insert oil level gauge and make sure the engine oil level is within the range (A) as shown.
3. If it is out of range, add oil as necessary.

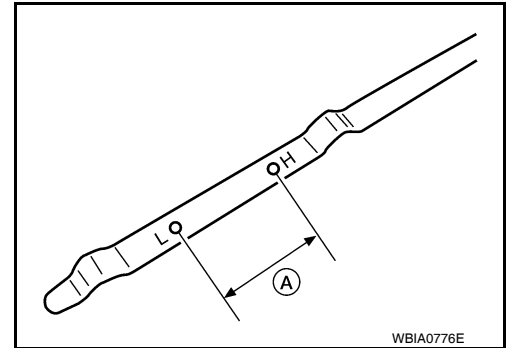

#### ENGINE OIL APPEARANCE

- Check engine oil for white milky appearance or excessive contamination.
- If engine oil becomes milky, it is highly probable that it is contaminated with engine coolant. Repair or replace damaged parts.

#### ENGINE OIL LEAKAGE

Check for engine oil leakage around the following areas:

- Oil pan (upper and lower)
- Oil pan drain plug
- Oil pressure switch
- Oil filter
- Intake valve timing control solenoid valve
- Front cover
- Mating surface between cylinder block and cylinder head
- Mating surface between cylinder head and rocker cover
- Crankshaft oil seals (front and rear)
- Oil filter (for intake valve timing control)

#### OIL PRESSURE CHECK

**WARNING:**

- Be careful not to burn yourself, as engine oil may be hot.
- For M/T models, put the shift selector in the Neutral "N" position and apply the parking brake securely. For CVT models, put the shift selector in the Park "P" position.

1. Check engine oil level.
2. Remove engine under cover. Refer to [EI-15. "Removal and Installation"](#).
3. Disconnect harness connector at oil pressure switch (1), and remove oil pressure switch using a suitable tool.

- Oil pan (lower) (2)
- ⇐: Front

**CAUTION:**

**Do not drop or shock oil pressure switch.**

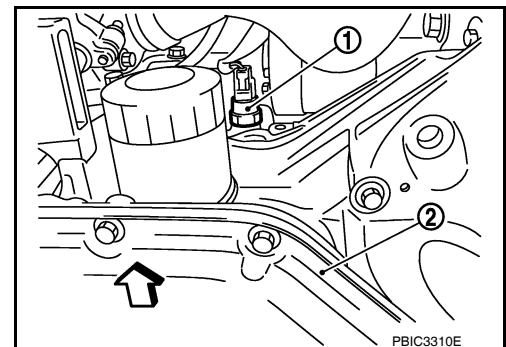

## ENGINE OIL

[MR20DE]

### < SERVICE INFORMATION >

4. Install oil pressure gauge and hose.

**Tool number** : ST25051001 (J-25695-1)  
: ST25052000 (J-25695-2)

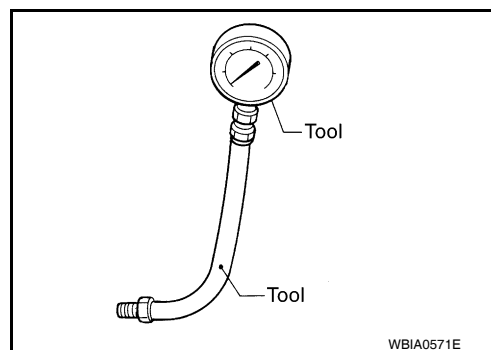

5. Start engine and warm it up to normal operating temperature.
6. Check oil pressure with engine running under no-load. Refer to [LU-11, "Oil Pressure"](#).

**NOTE:**

When engine oil temperature is low, engine oil pressure becomes high.

**If difference is extreme, check oil passage and oil pump for oil leaks.**

7. After the inspections, install oil pressure switch as follows:
  - a. Remove old liquid gasket adhering to oil pressure switch and engine.
  - b. Apply liquid gasket and tighten oil pressure switch to specification.  
**Use Genuine Silicone RTV Sealant or equivalent. Refer to [GI-44, "Recommended Chemical Product and Sealant"](#).**

**Oil pressure switch** : 14.7 N·m (1.5 kg-m, 11 ft-lb)

- c. Check engine oil level.
- d. After warming up engine, make sure there are no leaks of engine oil with running engine.

### Changing Engine Oil

INFOID:000000006152156

**WARNING:**

- Be careful not to burn yourself, as engine oil may be hot.
  - Prolonged and repeated contact with used engine oil may cause skin cancer; try to avoid direct skin contact with used engine oil. If skin contact is made, wash thoroughly with soap or hand cleaner as soon as possible.
1. Park vehicle on a level surface and check for engine oil leakage from engine components. Refer to [LU-6, "Inspection"](#).
  2. Warm up the engine.
  3. Stop engine and wait for 10 minutes.

## ENGINE OIL

[MR20DE]

### < SERVICE INFORMATION >

- Remove oil filler cap (1) and then remove oil pan drain plug (2).
  - Oil filter (3)
  - ⇐: Engine front
- Drain the engine oil.
- Install the oil pan drain plug (2) with a new washer.

**Oil pan drain plug : 34.3 N·m (3.5 kg·m, 25 ft·lb)**

**CAUTION:**

**Be sure to clean drain plug (2) and install with new washer.**

- Refill with new engine oil. Refer to [MA-15, "MR20DE"](#).

**CAUTION:**

- The refill capacity depends on the engine oil temperature and drain time. Use these specifications for reference only.
- Always use oil level gauge to determine the proper amount of engine oil in the engine.

- Warm up engine and check area around drain plug (2) and oil filter (3) for engine oil leakage.
- Stop engine and wait for 10 minutes.
- Check the engine oil level. Refer to [LU-6, "Inspection"](#).

**CAUTION:**

**Do not overfill the engine with oil.**

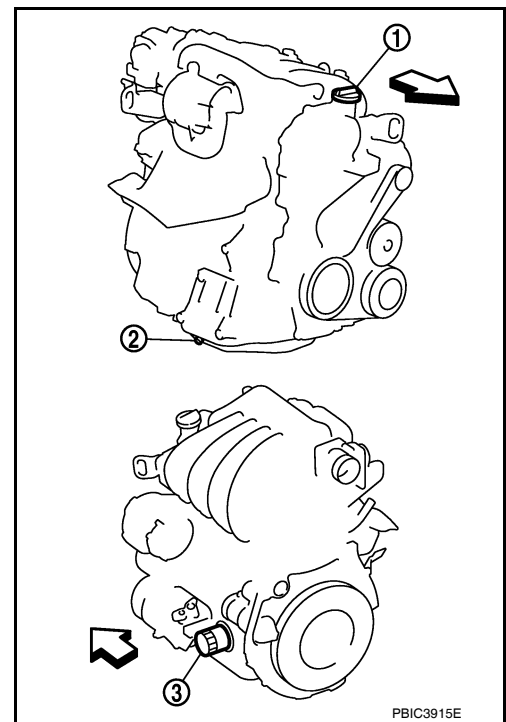

PBIC3915E



## OIL FILTER

### Removal and Installation

INFOID:000000006152157

#### REMOVAL

1. Remove engine under cover. Refer to [EI-15, "Removal and Installation"](#).
2. Drain engine oil. Refer to [LU-7, "Changing Engine Oil"](#).
3. Remove oil filter using Tool (A).

**Tool number** : KV10115801 (J-38956)

-  Front

**WARNING:**

Be careful not to get burned, engine and engine oil may be hot.

**CAUTION:**

- When removing, prepare a shop cloth to absorb any engine oil leakage or spillage.
  - Do not allow engine oil to adhere to drive belt.
  - Completely wipe off any engine oil that adheres to the engine and the vehicle.
- The oil filter has a built in pressure relief valve. Use Genuine NISSAN oil filter or equivalent.

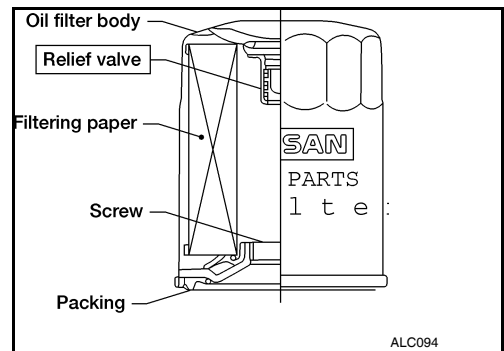
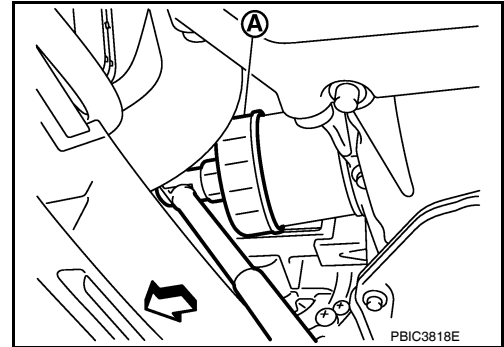

#### INSTALLATION

1. Remove foreign materials adhering to the oil filter installation surface.
2. Apply new engine oil to the oil seal contact surface of the new oil filter.

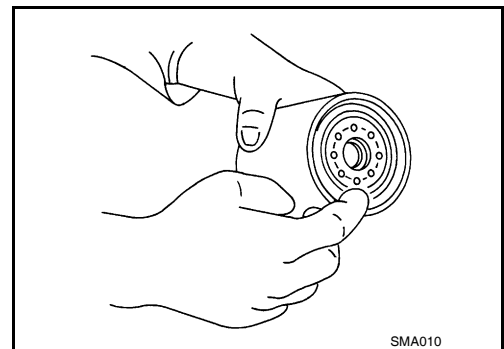

3. Screw the new oil filter manually until it touches the installation surface, then tighten it by 2/3 turn. Or tighten to specification.

**Oil filter:** : 17.7 N·m (1.8 kg·m, 13 ft·lb)

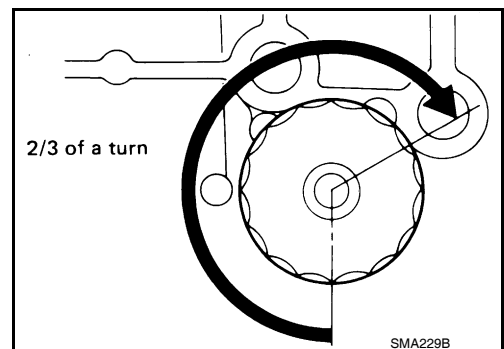

A  
C  
D  
E  
F  
G  
H  
I  
J  
K  
L  
M  
N  
O  
P

LU

## OIL FILTER

[MR20DE]

< SERVICE INFORMATION >

---

4. Refill engine with new engine oil. Refer to [LU-7, "Changing Engine Oil"](#).
5. Install engine under cover. Refer to [EI-15, "Removal and Installation"](#).

### INSPECTION AFTER INSTALLATION

1. Check the engine oil level. Refer to [LU-6](#).
2. Start engine, and make sure there are no leaks of engine oil.
3. Stop engine and wait for 10 minutes.
4. Check the engine oil level and adjust as necessary. Refer to [LU-6](#).

# SERVICE DATA AND SPECIFICATIONS (SDS)

< SERVICE INFORMATION >

[MR20DE]

## SERVICE DATA AND SPECIFICATIONS (SDS)

### Oil Pressure

INFOID:000000006152158

Unit: kPa (kg/cm<sup>2</sup>, psi)

Engine speed	Approximate discharge oil pressure
Idle speed	60 (0.61, 9)
2,000 rpm	200 (2.0, 29)

### Oil Capacity

INFOID:000000006152159

Unit: ℓ (US qt, Imp qt)

Drain and refill	With oil filter change	Approximately 3.9 (4 1/8, 3 3/8)
	Without oil filter change	Approximately 3.6 (3 7/8, 3 1/8)
Dry engine (engine overhaul)		Approximately 4.4 (4 5/8, 3 7/8)

A  
LU  
C  
D  
E  
F  
G  
H  
I  
J  
K  
L  
M  
N  
O  
P

## SERVICE INFORMATION

### PRECAUTIONS

#### Precaution for Supplemental Restraint System (SRS) "AIR BAG" and "SEAT BELT PRE-TENSIONER"

INFOID:000000006152160

The Supplemental Restraint System such as "AIR BAG" and "SEAT BELT PRE-TENSIONER", used along with a front seat belt, helps to reduce the risk or severity of injury to the driver and front passenger for certain types of collision. This system includes seat belt switch inputs and dual stage front air bag modules. The SRS system uses the seat belt switches to determine the front air bag deployment, and may only deploy one front air bag, depending on the severity of a collision and whether the front occupants are belted or unbelted. Information necessary to service the system safely is included in the SRS and SB section of this Service Manual.

#### **WARNING:**

- To avoid rendering the SRS inoperative, which could increase the risk of personal injury or death in the event of a collision which would result in air bag inflation, all maintenance must be performed by an authorized NISSAN/INFINITI dealer.
- Improper maintenance, including incorrect removal and installation of the SRS can lead to personal injury caused by unintentional activation of the system. For removal of Spiral Cable and Air Bag Module, see the SRS section.
- Do not use electrical test equipment on any circuit related to the SRS unless instructed to in this Service Manual. SRS wiring harnesses can be identified by yellow and/or orange harnesses or harness connectors.

#### PRECAUTIONS WHEN USING POWER TOOLS (AIR OR ELECTRIC) AND HAMMERS

#### **WARNING:**

- When working near the Airbag Diagnosis Sensor Unit or other Airbag System sensors with the Ignition ON or engine running, DO NOT use air or electric power tools or strike near the sensor(s) with a hammer. Heavy vibration could activate the sensor(s) and deploy the air bag(s), possibly causing serious injury.
- When using air or electric power tools or hammers, always switch the Ignition OFF, disconnect the battery, and wait at least 3 minutes before performing any service.

#### Precaution Necessary for Steering Wheel Rotation After Battery Disconnect

INFOID:000000006152161

#### **NOTE:**

- This Procedure is applied only to models with Intelligent Key system and NATS (NISSAN ANTI-THEFT SYSTEM).
- Remove and install all control units after disconnecting both battery cables with the ignition knob in the "LOCK" position.
- Always use CONSULT-III to perform self-diagnosis as a part of each function inspection after finishing work. If DTC is detected, perform trouble diagnosis according to self-diagnostic results.

For models equipped with the Intelligent Key system and NATS, an electrically controlled steering lock mechanism is adopted on the key cylinder.

For this reason, if the battery is disconnected or if the battery is discharged, the steering wheel will lock and steering wheel rotation will become impossible.

If steering wheel rotation is required when battery power is interrupted, follow the procedure below before starting the repair operation.

#### OPERATION PROCEDURE

1. Connect both battery cables.

#### **NOTE:**

Supply power using jumper cables if battery is discharged.

2. Use the Intelligent Key or mechanical key to turn the ignition switch to the "ACC" position. At this time, the steering lock will be released.
3. Disconnect both battery cables. The steering lock will remain released and the steering wheel can be rotated.
4. Perform the necessary repair operation.

# PRECAUTIONS

< SERVICE INFORMATION >

[QR25DE]

5. When the repair work is completed, return the ignition switch to the "LOCK" position before connecting the battery cables. (At this time, the steering lock mechanism will engage.)
6. Perform a self-diagnosis check of all control units using CONSULT-III.

A

**LU**

C

D

E

F

G

H

I

J

K

L

M

N

O

P

# PREPARATION

< SERVICE INFORMATION >

[QR25DE]

## PREPARATION

### Special Service Tool

INFOID:000000006152162

The actual shape of the Kent-Moore tools may differ from those tools illustrated here.

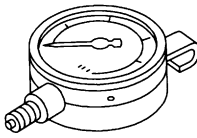
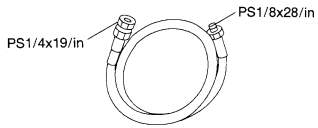
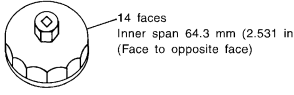
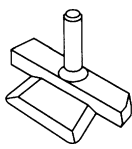
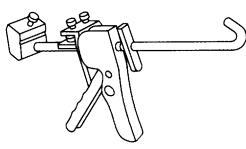
Tool number (Kent Moore No.) Tool name	Description
ST25051001 (J-25695-1) Oil pressure gauge	Measuring oil pressure <b>Maximum measuring range:</b> <b>2,452 kPa (25 kg/cm<sup>2</sup>, 356 psi)</b>
 S-NT050	
ST25052000 (J-25695-2) Hose	Adapting oil pressure gauge to cylinder block
 S-NT559	
KV10115801 (J-38956) Oil filter wrench	Removing and installing oil filter
 S-NT772	
KV10111100 (J-37228) Seal cutter	Removing steel oil pan and rear timing chain case
 S-NT046	
WS39930000 ( — ) Tube presser	Pressing the tube of liquid gasket
 S-NT052	

### Commercial Service Tool

INFOID:000000006152163

# PREPARATION

< SERVICE INFORMATION >

[QR25DE]

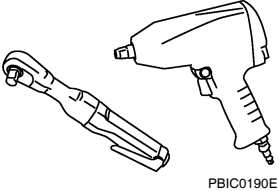
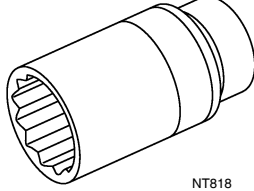
Tool name	Description
<p data-bbox="162 197 272 222">Power tool</p>  <p data-bbox="828 415 901 432">PBIC0190E</p>	<p data-bbox="1010 197 1263 222">Loosening bolts and nuts</p>
<p data-bbox="162 449 292 474">Deep socket</p>  <p data-bbox="828 667 868 684">NT818</p>	<p data-bbox="1010 449 1453 506">Removing and installing oil pressure sensor Deep socket 26 mm, 3/8 drive</p>

A

**LU**

C

D

E

F

G

H

I

J

K

L

M

N

O

P

# LUBRICATION SYSTEM

< SERVICE INFORMATION >

[QR25DE]

## LUBRICATION SYSTEM

### Lubrication Circuit

INFOID:000000006152164

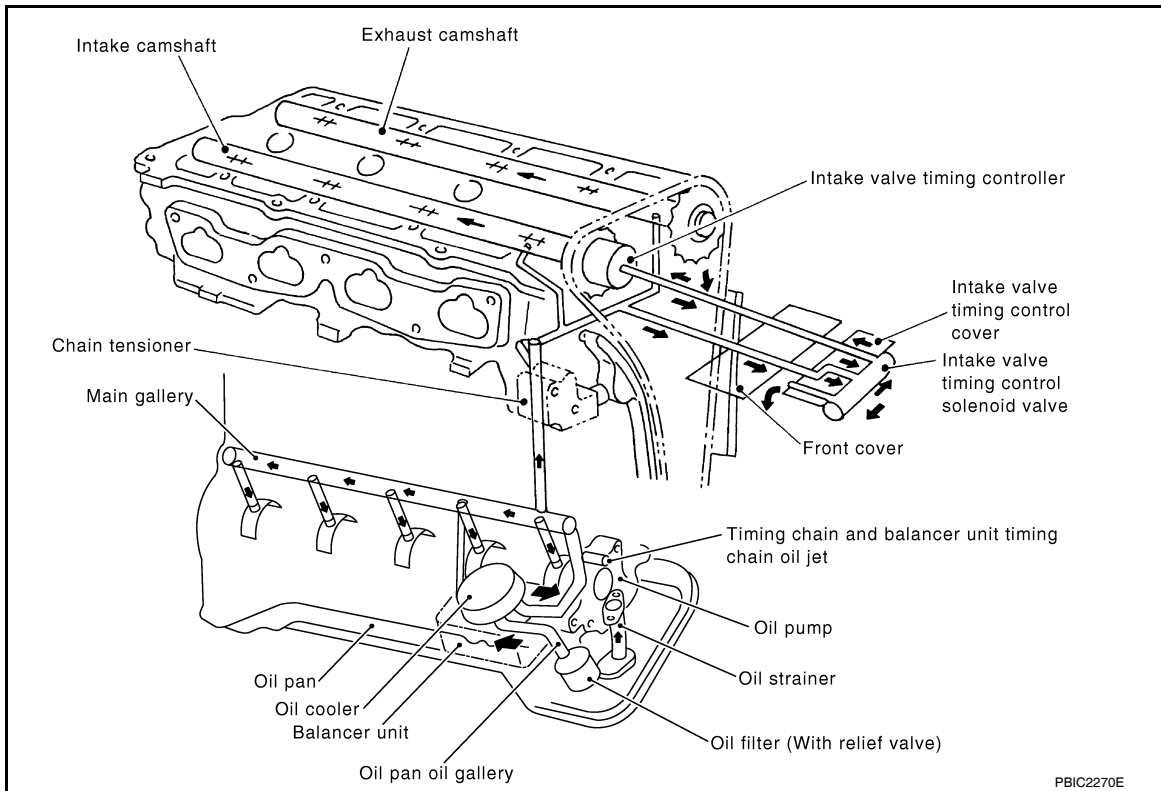

PBIC2270E

### Schematic

INFOID:000000006152165

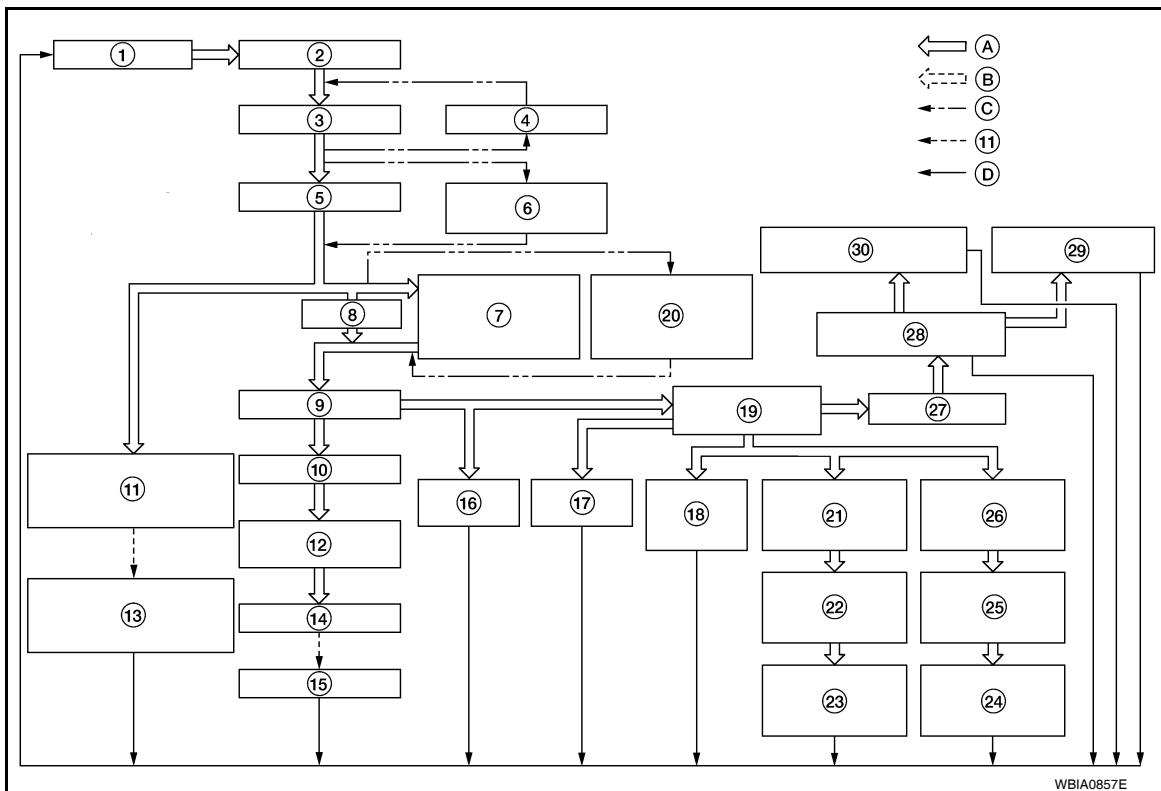

WBIA0857E

- |                    |                 |                                       |
|--------------------|-----------------|---------------------------------------|
| 1. Oil pan         | 2. Oil strainer | 3. Oil pump                           |
| 4. Regulator valve | 5. Oil filter   | 6. Relief valve (Built in oil filter) |



# LUBRICATION SYSTEM

< SERVICE INFORMATION >

[QR25DE]

- |   |   |  |           |
|---|---|--|-----------|
| 7. Oil cooler                                   | 8. Bypass   | 9. Connecting rod bearing                      | A         |
| 10. Main bearing                                | 11. Timing chain and balancer unit timing chain oil jet | 12. Connecting rod bearing                     | A         |
| 13. Timing chain and balancer unit timing chain | 14. Connecting Rod                                      | 15. Piston                                     | <b>LU</b> |
| 16. Balancer unit                               | 17. Chain tensioner                                     | 18. Camshaft bracket (No.1)                    |           |
| 19. Cylinder head oil gallery                   | 20. Relief valve  | 21. Intake camshaft bracket (No.2)             |           |
| 22. Intake camshaft oil passage                 | 23. Intake camshaft journal                             | 24. Exhaust camshaft journal                   | C         |
| 25. Exhaust camshaft oil passage                | 26. Exhaust camshaft bracket (No.2)                     | 27. Front cover                                |           |
| 28. Intake valve timing control cover           | 29. Intake valve timing controller                      | 30. Intake valve timing control solenoid valve | D         |
| A. Oil passage                                  | B. Return oil passage                                   | C. Bypass                                      |           |
| D. To oil pan                                   |   |  |           |

E

F

G

H

I

J

K

L

M

N

O

P

## ENGINE OIL

### Inspection

INFOID:000000006152166

#### ENGINE OIL LEVEL

**NOTE:**

Before starting engine, park vehicle on a level surface and check the engine oil level. If engine is already started, stop it and allow 10 minutes before checking.

1. Pull out oil level gauge and wipe it clean.
2. Insert oil level gauge and make sure the engine oil level is within the range as shown.
3. If it is out of range, add oil as necessary.

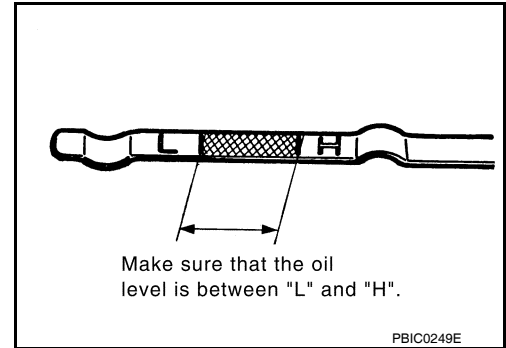

#### ENGINE OIL APPEARANCE

- Check engine oil for white milky appearance or excessive contamination.
- If engine oil becomes milky, it is highly probable that it is contaminated with engine coolant. Repair or replace damaged parts.

#### ENGINE OIL LEAKAGE

Check for engine oil leakage around the following areas:

- Oil pan (upper and lower)
- Oil pan drain plug
- Oil pressure sensor
- Oil filter
- Intake valve timing control solenoid valve
- Front cover
- Mating surface between cylinder block and cylinder head
- Mating surface between cylinder head and rocker cover
- Crankshaft oil seals (front and rear)

#### OIL PRESSURE CHECK

**WARNING:**

- **Be careful not to burn yourself, as engine oil may be hot.**
  - **For M/T models, put the shift selector in the Neutral "N" position and apply the parking brake securely.**
  - **For CVT models, put the shift selector in the Park "P" position.**
1. Check engine oil level.
  2. Remove engine under cover. Refer to [EI-15. "Removal and Installation"](#).
  3. Disconnect harness connector at oil pressure sensor, and remove oil pressure sensor using a suitable tool.

**CAUTION:**

**Do not drop or shock oil pressure sensor.**

## ENGINE OIL

< SERVICE INFORMATION >

[QR25DE]

4. Install oil pressure gauge and hose.

**Tool numbers** : ST25051001 (J-25695-1)  
: ST25052000 (J-25695-2)

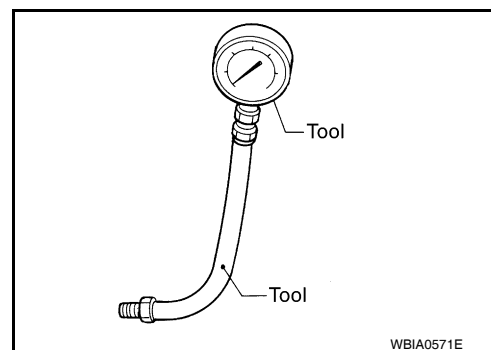

5. Start engine and warm it up to normal operating temperature.
6. Check oil pressure with engine running under no-load. Refer to [LU-27, "Oil Pressure"](#).

**NOTE:**

When engine oil temperature is low, engine oil pressure becomes high.

**If difference is extreme, check oil passage and oil pump for oil leaks.**

7. After the inspections, install oil pressure sensor as follows:
  - a. Remove old liquid gasket adhering to oil pressure sensor and engine.
  - b. Apply liquid gasket and tighten oil pressure sensor to specification.  
**Use Genuine RTV Silicone Sealant or equivalent. Refer to [GI-44, "Recommended Chemical Product and Sealant"](#).**

**Oil pressure sensor** : 14.7 N·m (1.5 kg-m, 11 ft-lb)

- c. Check engine oil level.
- d. After warming up engine, make sure there are no leaks of engine oil with running engine.

### Changing Engine Oil

INFOID:000000006152167

**WARNING:**

- Be careful not to burn yourself, as engine oil may be hot.
  - Prolonged and repeated contact with used engine oil may cause skin cancer; try to avoid direct skin contact with used engine oil. If skin contact is made, wash thoroughly with soap or hand cleaner as soon as possible.
1. Park vehicle on a level surface and check for engine oil leakage from engine components. Refer to [LU-18, "Inspection"](#).
  2. Warm up the engine.
  3. Stop engine and wait for 10 minutes.
  4. Remove oil filler cap and then remove oil pan drain plug.
  5. Drain the engine oil.
  6. Install the oil pan drain plug with a new washer.

**Oil pan drain plug** : 34.3 N·m (3.5 kg-m, 25 ft-lb)

**CAUTION:**

**Be sure to clean drain plug and install with new washer.**

7. Refill with new engine oil. Refer to [MA-15, "QR25DE"](#).  
**CAUTION:**
  - The refill capacity depends on the engine oil temperature and drain time. Use these specifications for reference only.
  - Always use oil level gauge to determine when the proper amount of engine oil in the engine.
8. Warm up engine and check area around drain plug and oil filter for engine oil leakage.
9. Stop engine and wait for 10 minutes.
10. Check the engine oil level. Refer to [LU-18, "Inspection"](#).  
**CAUTION:**  
**Do not overfill the engine with oil.**

## OIL FILTER

### Removal and Installation

INFOID:000000006152168

#### REMOVAL

1. Drain engine oil. Refer to [LU-19, "Changing Engine Oil"](#).
2. Remove splash shield RH. Refer to [EI-23, "Component"](#).
3. Remove the oil filter using Tool.

**Tool number : KV10115801 (J-38956)**

**WARNING:**

Be careful not to get burned, engine and engine oil may be hot.

**CAUTION:**

- When removing, prepare a shop cloth to absorb any engine oil leakage or spillage.
- Do not allow engine oil to adhere to drive belt.
- Completely wipe off any engine oil that adheres to the engine and the vehicle.

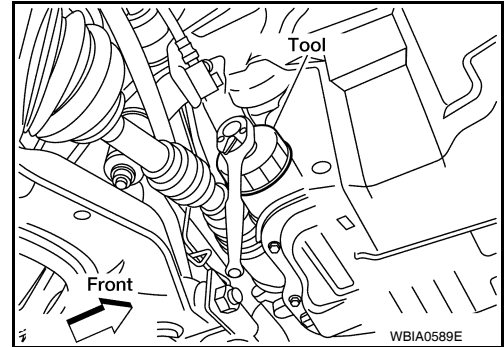

- The oil filter has a built in pressure relief valve. Use Genuine NISSAN oil filter or equivalent

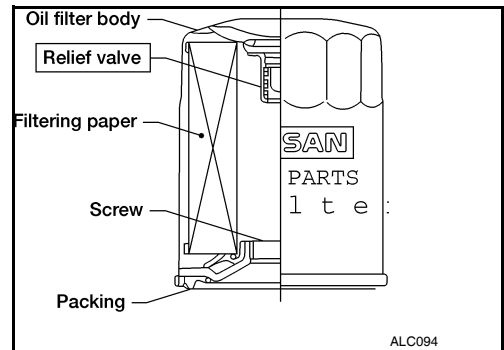

#### INSTALLATION

1. Remove foreign materials adhering to the oil filter installation surface.
2. Apply new engine oil to the oil seal contact surface of the new oil filter.

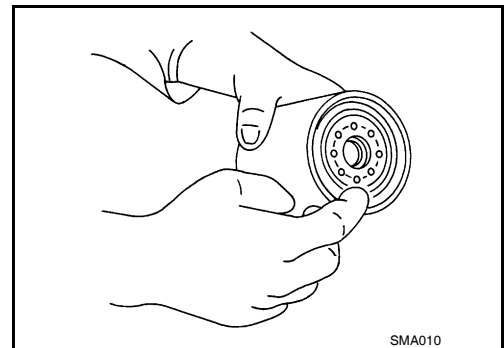

3. Screw the new oil filter manually until it touches the installation surface, then tighten it by 2/3 turn. Or tighten to specification.

**Oil filter : 17.7 N·m (1.8 kg·m, 13 ft·lb)**

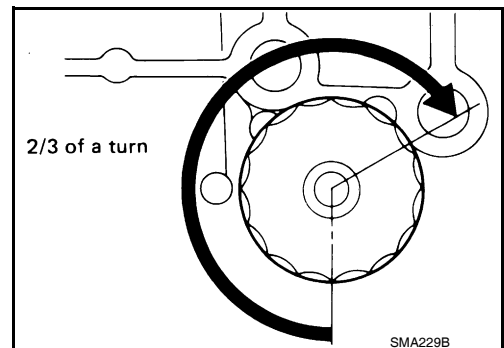

# OIL FILTER

[QR25DE]

## < SERVICE INFORMATION >

4. Refill engine with new engine oil. Refer to [LU-19, "Changing Engine Oil"](#).
5. Install splash shield RH. Refer to [EI-23, "Component"](#).

A

## INSPECTION AFTER INSTALLATION

1. Check the engine oil level. Refer to [LU-18](#).
2. Start engine, and make sure there are no leaks of engine oil.
3. Stop engine and wait for 10 minutes.
4. Check the engine oil level and adjust as necessary. Refer to [LU-18, "Inspection"](#).

LU

C

D

E

F

G

H

I

J

K

L

M

N

O

P

# OIL PUMP

< SERVICE INFORMATION >

[QR25DE]

## OIL PUMP

### Removal and Installation

INFOID:000000006152169

- Remove the front cover. Refer to [EM-164. "Removal and Installation"](#).

### Disassembly and Assembly

INFOID:000000006152170

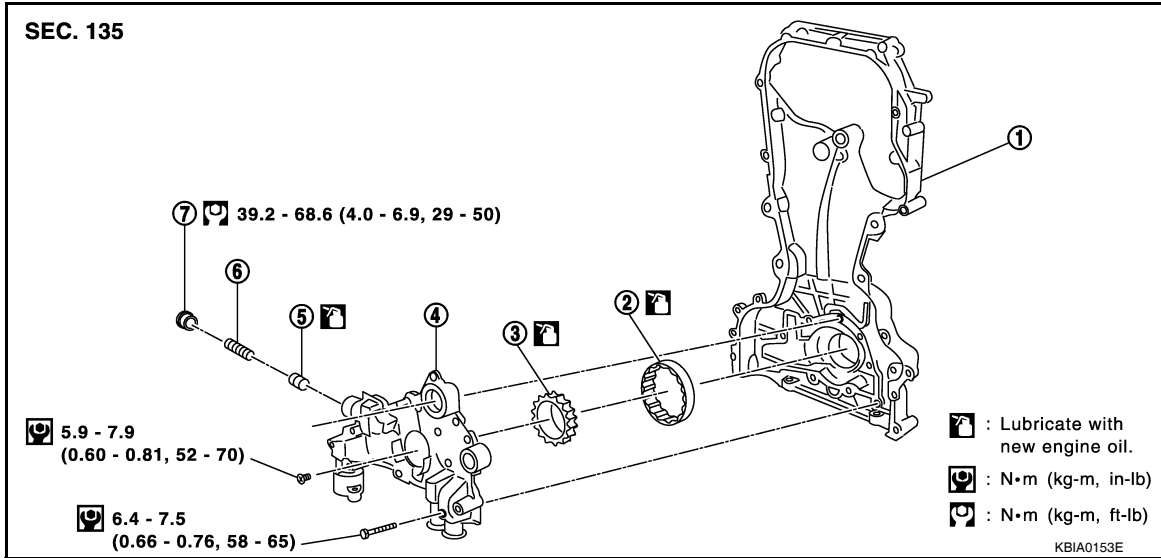

- |                   |                    |                |
|-------------------|--------------------|----------------|
| 1. Front cover    | 2. Outer rotor     | 3. Inner rotor |
| 4. Oil pump cover | 5. Regulator valve | 6. Spring      |
| 7. Regulator plug |                    |                |

### CAUTION:

Before installation, apply new engine oil to the parts as shown.

### DISASSEMBLY

1. Remove the oil pump cover.
2. Remove inner rotor and outer rotor from front cover.
3. After removing regulator plug, remove regulator spring and regulator valve.

### INSPECTION AFTER DISASSEMBLY

#### Measure the clearance of the oil pump parts.

- Measure clearance with feeler gauge.
- Clearance between outer rotor and oil pump body (position 1).

**Standard : 0.114 - 0.179 mm (0.0045 - 0.0070 in)**

- Tip clearance between inner rotor and outer rotor (position 2).

**Standard : 0.170 - 0.220 mm (0.0067 - 0.0087 in)**

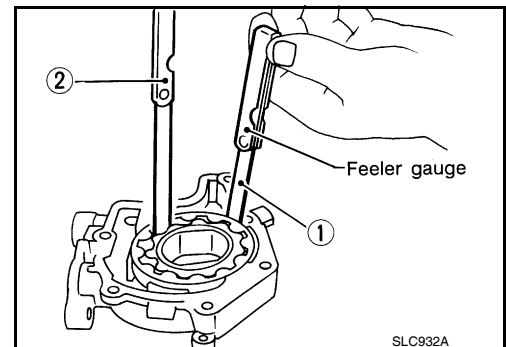

# OIL PUMP

[QR25DE]

## < SERVICE INFORMATION >

- Measure clearance with feeler gauge and straightedge.
- Side clearance between inner rotor and oil pump body (position 3).

**Standard : 0.030 - 0.070 mm (0.0012 - 0.0028 in)**

- Side clearance between outer rotor and oil pump body (position 4).

**Standard : 0.060 - 0.110 mm (0.0024 - 0.0043 in)**

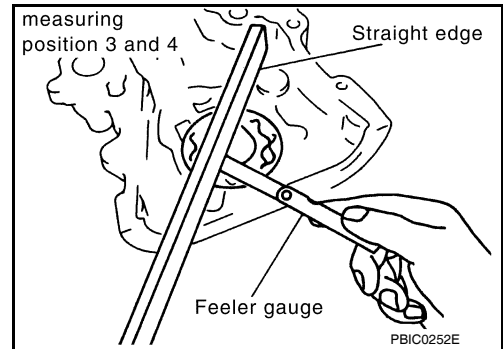

- Calculate the clearance between inner rotor and oil pump body as follows:

1. Measure the outer diameter of protruded portion of inner rotor (Position 5).

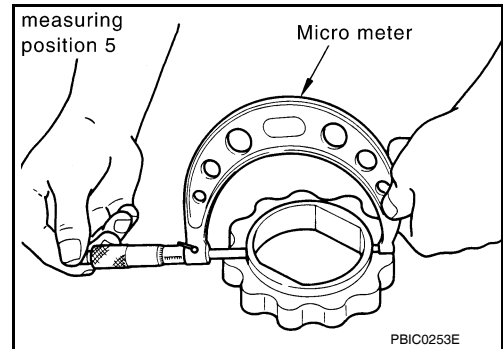

2. Measure the inner diameter of oil pump body with inside micrometer (Position 6).  
(Clearance) = (Inner diameter of oil pump body) – (Outer diameter of inner rotor).

**Standard : 0.035 - 0.070 mm (0.0014 - 0.0028 in)**

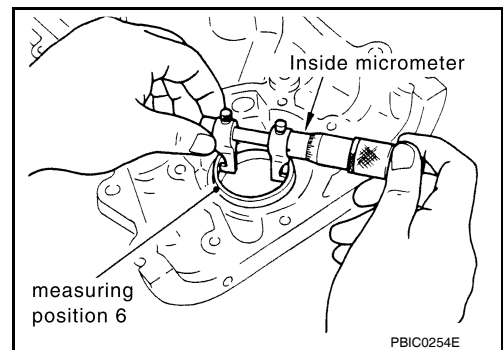

- Regulator valve clearance:  
(Clearance) = D1 (Valve hole diameter) – D2 (Outer diameter of valve)

**Standard : 0.040 - 0.097 mm (0.0016 - 0.0038 in)**

### CAUTION:

Coat regulator valve with engine oil.

Check that it falls smoothly into the valve hole by its own weight.

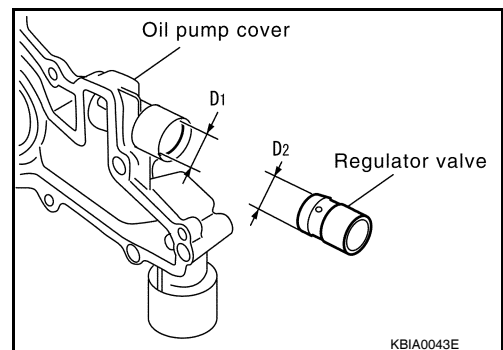

## ASSEMBLY

## OIL PUMP

[QR25DE]

### < SERVICE INFORMATION >

- Assembly is in the reverse order of disassembly.
- Install the inner rotor and outer rotor with the punched marks on the oil pump cover side.

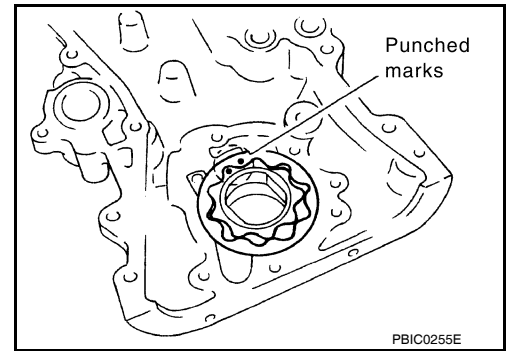



## OIL COOLER

## Removal and Installation

INFOID:000000006152171

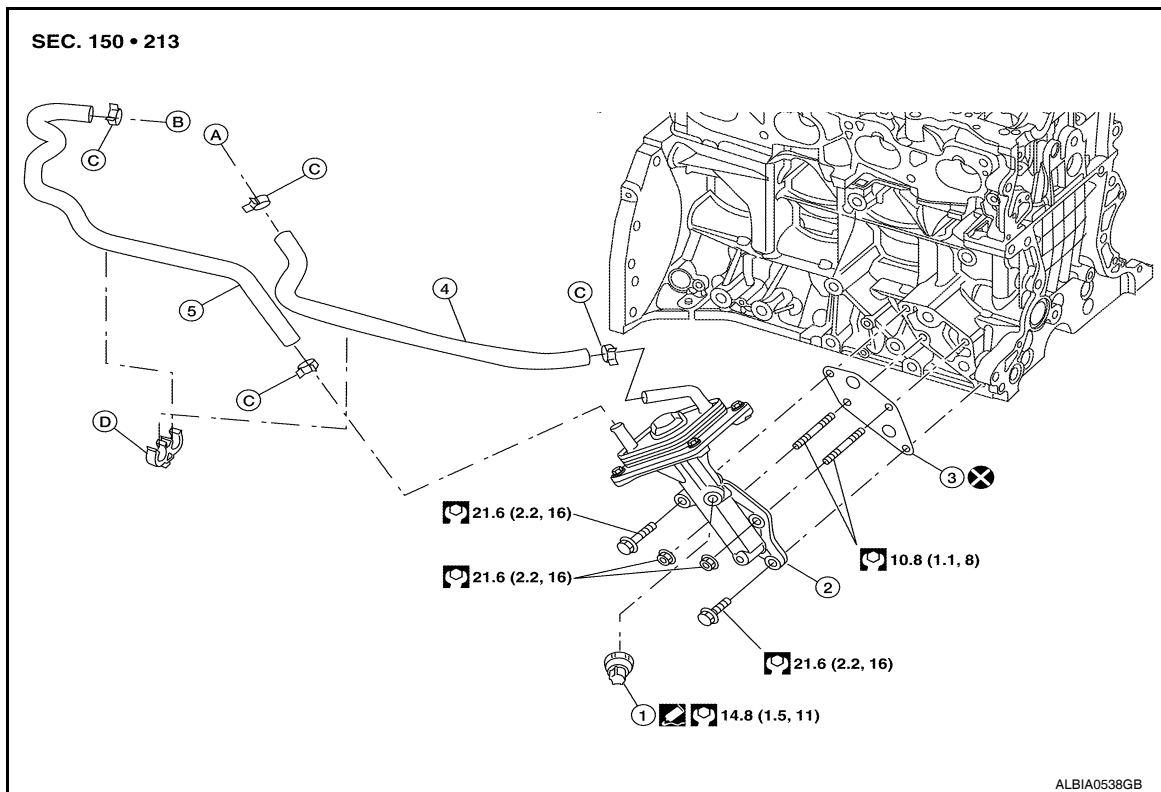

- |                            |                       |                                   |
|----------------------------|-----------------------|-----------------------------------|
| 1. Oil pressure sensor     | 2. Oil cooler         | 3. Gasket                         |
| 4. Water hose (outlet)     | 5. Water hose (inlet) | A. To water control valve housing |
| B. To heater pipe assembly | C. Hose clamp         | D. Clip                           |

**WARNING:**

Be careful not to get burned, engine coolant and engine oil may be hot.

**CAUTION:**

- When removing oil cooler, prepare a shop cloth to absorb any engine oil leakage or spillage.
- Completely wipe off any engine oil that adheres to the engine and the vehicle.

## REMOVAL

1. Drain engine oil. Refer to [LU-19, "Changing Engine Oil"](#).
  2. Drain engine coolant. Refer to [CO-40, "Changing Engine Coolant"](#).
- CAUTION:**
- Do not spill coolant on the drive belt.**
3. Remove the RH front wheel and tire. Refer to [WT-7, "Adjustment"](#).
  4. Remove the splash shield RH. Refer to [EI-23, "Component"](#).
  5. Disconnect the oil pressure sensor.
  6. Remove the front exhaust tube. Refer to [EX-11, "Component"](#).
  7. Disconnect water hoses from oil cooler.

**NOTE:**

- For reference during installation, put matching marks on oil cooler hoses.
- Cap or plug opening(s) to prevent fluid from spilling.

8. Remove oil cooler.
9. Remove oil pressure sensor, if necessary.

## OIL COOLER

[QR25DE]

< SERVICE INFORMATION >

---

### INSPECTION AFTER REMOVAL

1. Check oil cooler for cracks.
2. Check oil cooler for clogging by blowing through coolant inlet. If necessary, replace oil cooler assembly.

### INSTALLATION

Installation is in the reverse order of removal.

- Remove any old liquid gasket adhering to the oil pressure sensor and oil cooler before installing the oil pressure sensor.

### INSPECTION AFTER INSTALLATION

Start engine and check for leaks of engine oil or coolant.

# SERVICE DATA AND SPECIFICATIONS (SDS)

< SERVICE INFORMATION >

[QR25DE]

## SERVICE DATA AND SPECIFICATIONS (SDS)

### Oil Pressure

INFOID:000000006152172

Unit: kPa (kg/cm<sup>2</sup>, psi)

Engine speed	Approximate discharge oil pressure
Idle speed	More than 98 (1.0, 14)
2,000 rpm	294 (3.0, 43)
6,000 rpm	392 (4.0, 57)

### Oil Pump

INFOID:000000006152173

Unit: mm (in)

Body to outer rotor radial clearance	0.114 - 0.179 (0.0045 - 0.0070)
Inner rotor to outer rotor tip clearance	0.170 - 0.220 (0.0067 - 0.0087)
Body to inner rotor axial clearance	0.030 - 0.070 (0.0012 - 0.0028)
Body to outer rotor axial clearance	0.060 - 0.110 (0.0024 - 0.0043)
Inner rotor to oil pump body clearance	0.035 - 0.070 (0.0014 - 0.0028)

### Regulator Valve

INFOID:000000006152174

Unit: mm (in)

Regulator valve to oil pump cover clearance	0.040 - 0.097 (0.0016 - 0.0038)
---	---------------------------------

### Oil Capacity

INFOID:000000006152175

Unit: ℓ (US qt, Imp qt)

Drain and refill	With oil filter change	Approximately 4.3 (4 1/2, 3 3/4)
	Without oil filter change	Approximately 4.0 (4 1/4, 3 1/2)
Dry engine (engine overhaul)		Approximately 5.1 (5 3/8, 4 1/2)