

# SECTION **SC**

## STARTING & CHARGING SYSTEM

A  
B  
C  
D  
E  
F  
G  
H  
I  
J  
SC  
L  
M  
N  
O  
P

### CONTENTS

<p><b>SERVICE INFORMATION</b> ..... 2</p> <p><b>PRECAUTIONS</b> ..... 2</p> <p style="padding-left: 20px;">Precaution for Supplemental Restraint System (SRS) "AIR BAG" and "SEAT BELT PRE-TENSIONER" .....2</p> <p style="padding-left: 20px;">Precaution Necessary for Steering Wheel Rotation After Battery Disconnect .....2</p> <p><b>PREPARATION</b> ..... 4</p> <p style="padding-left: 20px;">Special Service Tool .....4</p> <p style="padding-left: 20px;">Commercial Service Tool .....4</p> <p><b>BATTERY</b> ..... 5</p> <p style="padding-left: 20px;">How to Handle Battery .....5</p> <p style="padding-left: 20px;">Trouble Diagnosis with Multitasking Battery Diagnostic Station .....7</p> <p style="padding-left: 20px;">Removal and Installation (MR20DE Battery) .....7</p> <p style="padding-left: 20px;">Removal and Installation (QR25DE Battery) .....8</p> <p style="padding-left: 20px;">Exploded View (QR25DE Battery Tray) .....9</p> <p style="padding-left: 20px;">Removal and Installation (QR25DE Battery Tray).....9</p> <p style="padding-left: 20px;">Required Procedures After Battery Disconnection... 10</p>	<p><b>STARTING SYSTEM</b> .....11</p> <p style="padding-left: 20px;">System Description .....11</p> <p style="padding-left: 20px;">Wiring Diagram - START - .....13</p> <p style="padding-left: 20px;">Trouble Diagnosis with Multitasking Battery Diagnostic Station (Starting) .....20</p> <p style="padding-left: 20px;">Removal and Installation MR20DE .....24</p> <p style="padding-left: 20px;">Removal and Installation QR25DE .....24</p> <p><b>CHARGING SYSTEM</b> .....26</p> <p style="padding-left: 20px;">System Description .....26</p> <p style="padding-left: 20px;">Wiring Diagram - CHARGE - .....27</p> <p style="padding-left: 20px;">Trouble Diagnosis with Multitasking Battery Diagnostic Station (Charging) .....29</p> <p style="padding-left: 20px;">Removal and Installation MR20DE .....32</p> <p style="padding-left: 20px;">Removal and Installation QR25DE .....33</p> <p style="padding-left: 20px;">Generator Pulley Inspection .....33</p> <p><b>SERVICE DATA AND SPECIFICATIONS (SDS)</b> .....35</p> <p style="padding-left: 20px;">Battery .....35</p> <p style="padding-left: 20px;">Starter .....35</p> <p style="padding-left: 20px;">Generator .....35</p>
---	--

# PRECAUTIONS

< SERVICE INFORMATION >

## SERVICE INFORMATION

### PRECAUTIONS

#### Precaution for Supplemental Restraint System (SRS) "AIR BAG" and "SEAT BELT PRE-TENSIONER"

INFOID:000000006152125

The Supplemental Restraint System such as "AIR BAG" and "SEAT BELT PRE-TENSIONER", used along with a front seat belt, helps to reduce the risk or severity of injury to the driver and front passenger for certain types of collision. This system includes seat belt switch inputs and dual stage front air bag modules. The SRS system uses the seat belt switches to determine the front air bag deployment, and may only deploy one front air bag, depending on the severity of a collision and whether the front occupants are belted or unbelted. Information necessary to service the system safely is included in the SRS and SB section of this Service Manual.

#### **WARNING:**

- To avoid rendering the SRS inoperative, which could increase the risk of personal injury or death in the event of a collision which would result in air bag inflation, all maintenance must be performed by an authorized NISSAN/INFINITI dealer.
- Improper maintenance, including incorrect removal and installation of the SRS can lead to personal injury caused by unintentional activation of the system. For removal of Spiral Cable and Air Bag Module, see the SRS section.
- Do not use electrical test equipment on any circuit related to the SRS unless instructed to in this Service Manual. SRS wiring harnesses can be identified by yellow and/or orange harnesses or harness connectors.

#### PRECAUTIONS WHEN USING POWER TOOLS (AIR OR ELECTRIC) AND HAMMERS

#### **WARNING:**

- When working near the Airbag Diagnosis Sensor Unit or other Airbag System sensors with the Ignition ON or engine running, DO NOT use air or electric power tools or strike near the sensor(s) with a hammer. Heavy vibration could activate the sensor(s) and deploy the air bag(s), possibly causing serious injury.
- When using air or electric power tools or hammers, always switch the Ignition OFF, disconnect the battery, and wait at least 3 minutes before performing any service.

#### Precaution Necessary for Steering Wheel Rotation After Battery Disconnect

INFOID:000000006152126

#### **NOTE:**

- This Procedure is applied only to models with Intelligent Key system and NATS (NISSAN ANTI-THEFT SYSTEM).
- Remove and install all control units after disconnecting both battery cables with the ignition knob in the "LOCK" position.
- Always use CONSULT-III to perform self-diagnosis as a part of each function inspection after finishing work. If DTC is detected, perform trouble diagnosis according to self-diagnostic results.

For models equipped with the Intelligent Key system and NATS, an electrically controlled steering lock mechanism is adopted on the key cylinder.

For this reason, if the battery is disconnected or if the battery is discharged, the steering wheel will lock and steering wheel rotation will become impossible.

If steering wheel rotation is required when battery power is interrupted, follow the procedure below before starting the repair operation.

#### OPERATION PROCEDURE

1. Connect both battery cables.

#### **NOTE:**

Supply power using jumper cables if battery is discharged.

2. Use the Intelligent Key or mechanical key to turn the ignition switch to the "ACC" position. At this time, the steering lock will be released.
3. Disconnect both battery cables. The steering lock will remain released and the steering wheel can be rotated.
4. Perform the necessary repair operation.

## PRECAUTIONS

### < SERVICE INFORMATION >

---

5. When the repair work is completed, return the ignition switch to the "LOCK" position before connecting the battery cables. (At this time, the steering lock mechanism will engage.)
6. Perform a self-diagnosis check of all control units using CONSULT-III.

A

B

C

D

E

F

G

H

I

J

SC

L

M

N

O

P

# PREPARATION

< SERVICE INFORMATION >

## PREPARATION

### Special Service Tool

INFOID:000000006152127

The actual shapes of Kent-Moore tools may differ from those of special service tools illustrated here.

Tool number (Kent-Moore No.) Tool name	Description
<p>— ( — ) Model GR-8 Multitasking Battery Diagnostic Station</p> <div style="text-align: center;">  <p>AWI1A1239ZZ</p> </div>	<p>Tests batteries, starting and charging systems. For operating instructions, refer to diagnostic station instruction manual.</p>

### Commercial Service Tool

INFOID:000000006152128

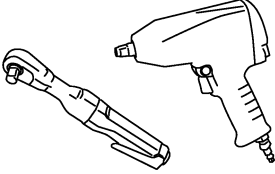
Tool name	Description
<p>Power tool</p> <div style="text-align: center;">  <p>PBIC0190E</p> </div>	<p>Loosening bolts and nuts</p>

# BATTERY

< SERVICE INFORMATION >

## BATTERY

### How to Handle Battery

INFOID:000000006152129

#### CAUTION:

- If it becomes necessary to start the engine with a booster battery and jumper cables, use a 12-volt booster battery.
- After connecting battery cables, ensure that they are tightly clamped to battery terminals for good contact.
- Never add distilled water through the hole used to check specific gravity.

#### METHODS OF PREVENTING OVER-DISCHARGE

The following precautions must be taken to prevent over-discharging a battery.

- The battery surface (particularly its top) should always be kept clean and dry.
- The terminal connections should be clean and tight.
- At every routine maintenance, check the electrolyte level. This also applies to batteries designated as “low maintenance” and “maintenance-free”.

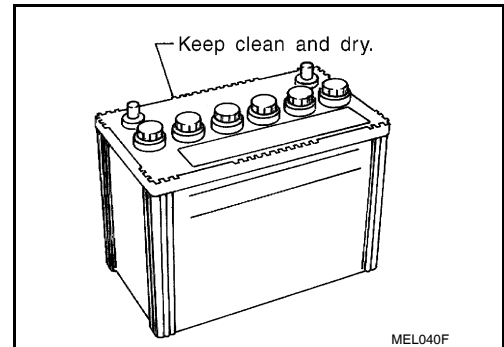

- When the vehicle is not going to be used over a long period of time, disconnect the negative battery terminal.

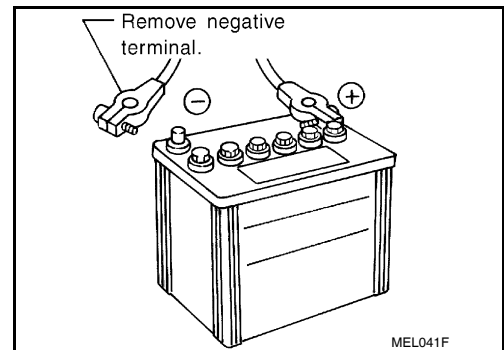

- Check the charge condition of the battery. Periodically check the specific gravity of the electrolyte. Keep a close check on charge condition to prevent over-discharge.

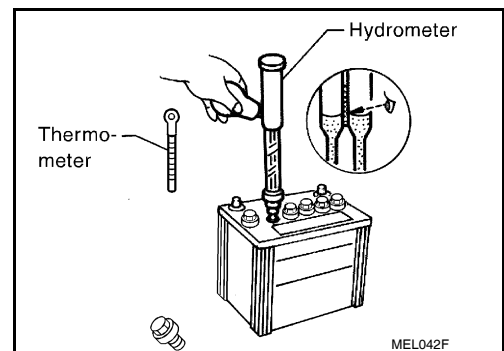

#### CHECKING ELECTROLYTE LEVEL

#### WARNING:

Do not allow battery fluid to come in contact with skin, eyes, fabrics, or painted surfaces. After touching a battery, do not touch or rub your eyes until you have thoroughly washed your hands. If acid contacts eyes, skin or clothing, immediately flush with water for 15 minutes and seek medical attention.

A  
B  
C  
D  
E  
F  
G  
H  
I  
J  
SC  
L  
M  
N  
O  
P

# BATTERY

## < SERVICE INFORMATION >

- Remove the cell plug using a suitable tool.
- Add distilled water up to the MAX level.

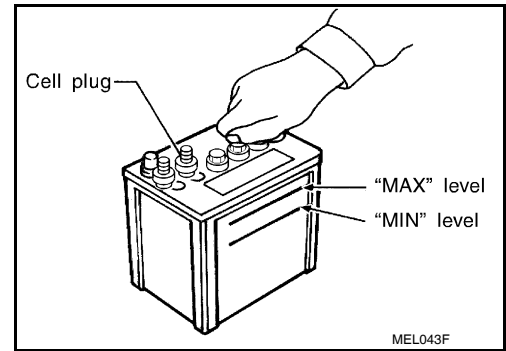

### Sulfation

**A battery will be completely discharged if it is left unattended for a long time and the specific gravity will become less than 1.100. This may result in sulfation on the cell plates.**

**To determine if a battery has been sulfated, note its voltage and current when charging it. Less current and higher voltage are observed in the initial stage of charging sulfated batteries, as shown.**

**A sulfated battery may sometimes be brought back into service by means of a long, slow charge, 12 hours or more, followed by a battery capacity test.**

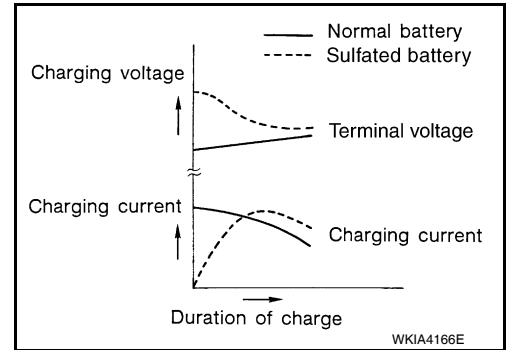

### SPECIFIC GRAVITY CHECK

1. Read hydrometer and thermometer indications at eye level.
2. Use the following chart to correct your hydrometer reading according to electrolyte temperature.

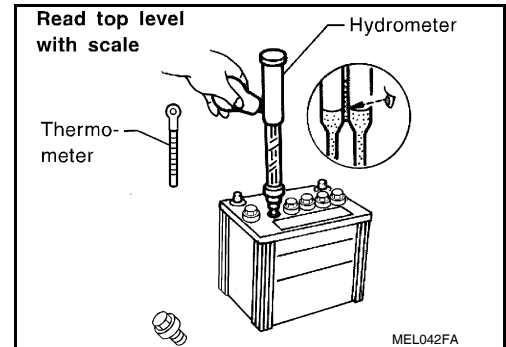

### Hydrometer Temperature Correction

Battery electrolyte temperature °C (°F)	Add to specific gravity reading
71 (160)	0.032
66 (150)	0.028
60 (140)	0.024
54 (130)	0.020
49 (120)	0.016
43 (110)	0.012
38 (100)	0.008
32 (90)	0.004
27 (80)	0
21 (70)	-0.004
16 (60)	-0.008
10 (50)	-0.012
4 (40)	-0.016
-1 (30)	-0.020

# BATTERY

## < SERVICE INFORMATION >

Battery electrolyte temperature °C (°F)	Add to specific gravity reading
-7 (20)	-0.024
-12 (10)	-0.028
-18 (0)	-0.032

Corrected specific gravity	Approximate charge condition
1.260 - 1.280	Fully charged
1.230 - 1.250	3/4 charged
1.200 - 1.220	1/2 charged
1.170 - 1.190	1/4 charged
1.140 - 1.160	Almost discharged
1.110 - 1.130	Completely discharged

## CHARGING THE BATTERY

### CAUTION:

- Do not “quick charge” a fully discharged battery.
- Keep the battery away from open flame while it is being charged.
- When connecting the charger, connect the leads first, then turn on the charger. Do not turn on the charger first, as this may cause a spark.
- If battery electrolyte temperature rises above 55°C (131°F), stop charging. Always charge battery at a temperature below 55°C (131°F).

### Charging Rates

Amps	Time
50	1 hour
25	2 hours
10	5 hours
5	10 hours

**Do not charge at more than 50 ampere rate.**

### NOTE:

The ammeter reading on your battery charger will automatically decrease as the battery charges. This indicates that the voltage of the battery is increasing normally as the state of charge improves. The charging amps indicated above refer to initial charge rate.

- If, after charging, the specific gravity of any two cells varies more than 0.050, the battery should be replaced.

## Trouble Diagnosis with Multitasking Battery Diagnostic Station

INFOID:000000006152130

Refer to diagnostic station instruction manual.

## Removal and Installation (MR20DE Battery)

INFOID:000000006152131

### REMOVAL MR20DE

1. Loosen battery terminal nuts (A), and disconnect both negative and positive battery terminals.

### CAUTION:

**When disconnecting, disconnect the battery negative terminal first.**

2. Remove battery frame nuts (B) and battery frame.
3. Remove battery.

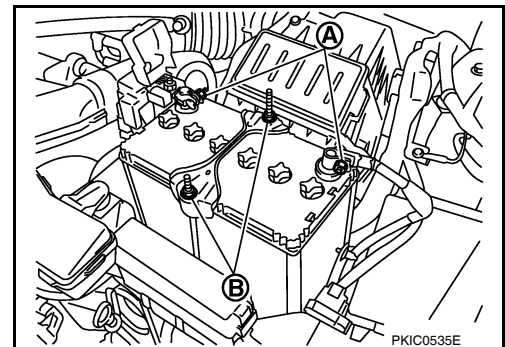

# BATTERY

## < SERVICE INFORMATION >

### INSTALLATION

Installation is in the reverse order of removal.

**CAUTION:**

**When connecting, connect the battery positive terminal first.**

**Battery frame nuts : 5.4 N·m (0.55 kg-m, 48 in-lb)**

**Battery terminal nuts : 5.4 N·m (0.55 kg-m, 48 in-lb)**

Reset electronic systems as necessary. Refer to [SC-10, "Required Procedures After Battery Disconnection"](#).

### Removal and Installation (QR25DE Battery)

INFOID:000000006152132

#### REMOVAL

1. Loosen battery terminal nuts (A), and disconnect both negative and positive battery terminals.

**CAUTION:**

**When disconnecting, disconnect the battery negative terminal first.**

2. Remove battery hold-down wedge bolt (B) and battery wedge bracket.
3. Remove battery.
4. Remove battery tray liner, if necessary.

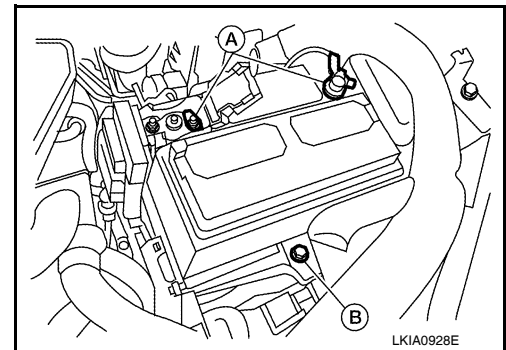

#### INSTALLATION

Installation is in the reverse order of removal.

**CAUTION:**

**When connecting, connect the battery positive terminal first.**

**Battery wedge bracket bolt : 30 N·m (3.1 kg-m, 22 ft-lb)**

**Battery terminal nuts : 5.4 N·m (0.55 kg-m, 48 in-lb)**

Reset electronic systems as necessary. Refer to [SC-10, "Required Procedures After Battery Disconnection"](#).



# BATTERY

< SERVICE INFORMATION >

## Exploded View (QR25DE Battery Tray)

INFOID:000000006152133

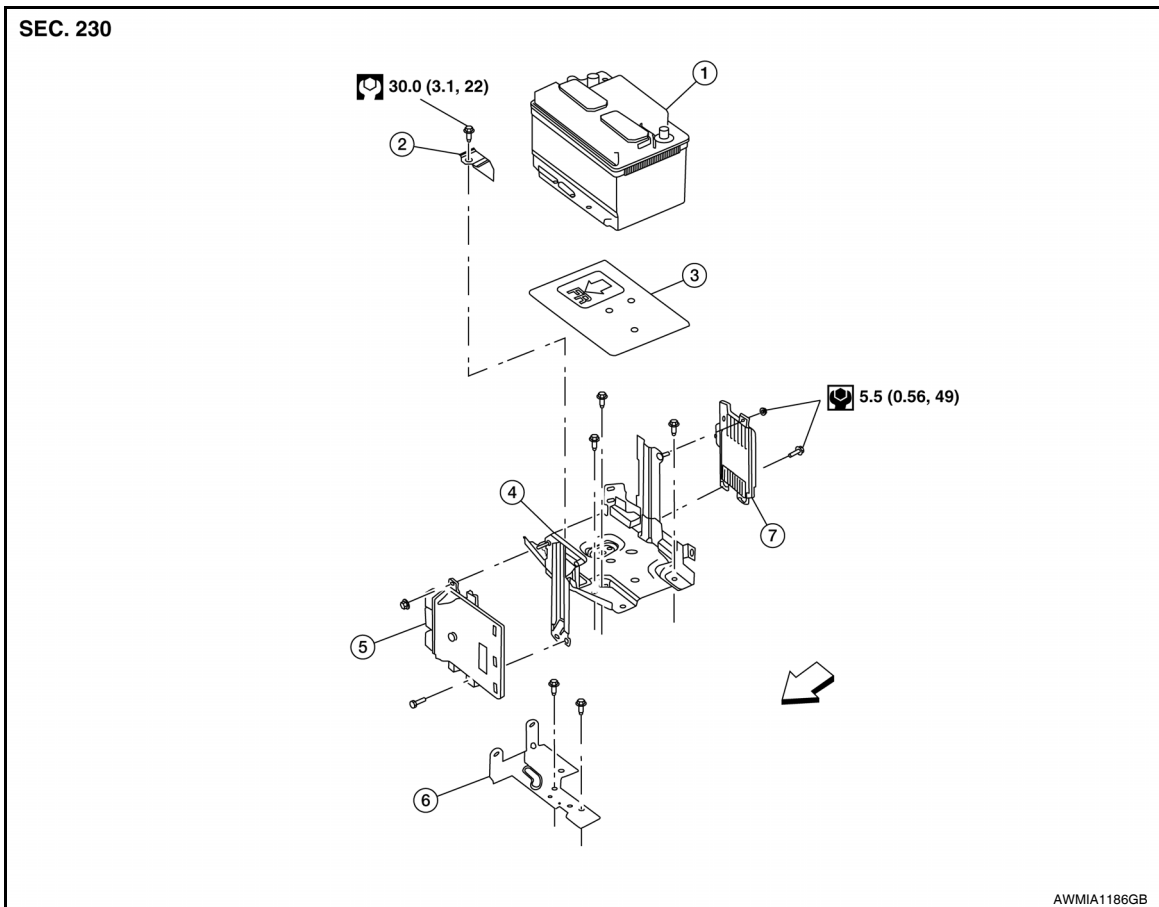

- |   |                          |                        |
|---|--------------------------|------------------------|
| 1. Battery  | 2. Battery wedge bracket | 3. Battery tray liner  |
| 4. Battery tray                                   | 5. ECM                   | 6. ECM harness bracket |
| 7. Transmission control module (TCM) (CVT models) | ← Vehicle front          |                        |

## Removal and Installation (QR25DE Battery Tray)

INFOID:000000006152134

### REMOVAL

1. Remove battery and battery tray liner. Refer to [SC-8. "Removal and Installation \(QR25DE Battery\)"](#).
2. Disconnect ECM.
3. Disconnect TCM (CVT models).
4. Remove the battery tray bolts and battery tray.
5. Remove the ECM harness bracket, if necessary.
6. Remove the ECM, if necessary.
7. Remove the TCM (CVT models), if necessary.

### INSTALLATION

Installation is in the reverse order of removal.

Reset electronic systems as necessary. Refer to [SC-10. "Required Procedures After Battery Disconnection"](#).

# BATTERY

< SERVICE INFORMATION >

## Required Procedures After Battery Disconnection

INFOID:000000006152135

System	Item	Reference
Engine Control System	Idle Air Volume Learning	<a href="#">EC-99</a> (MR20DE for California) <a href="#">EC-649</a> (MR20DE except for California) <a href="#">EC-1183</a> (QR25DE)
Glasses, Window System & Mirrors	Power Window System Initialization	<a href="#">GW-51</a>
Roof	Sunroof Memory Reset/Initialization	<a href="#">RF-11</a>
Audio, Visual, Navigation & Telephone System	Audio (Radio Preset)	Refer to Owner's Manual.
	Navigation System	Refer to Owner's Manual.

# STARTING SYSTEM

< SERVICE INFORMATION >

## STARTING SYSTEM

### System Description

INFOID:000000006152136

#### M/T Models with MR20DE

Power is supplied at all times

- through 225A fusible link [letter **a**, located in the fusible link box (battery) or
- to starter motor terminal B and
- through 40A fusible link (letter **m**, located in the fuse and fusible link box)
- to ignition switch terminal B.

With the ignition switch in the START position, power is supplied

- from ignition switch terminal ST
- to IPDM E/R terminal 21.

With the ignition switch in the ON or START position, power is supplied

- through 10A fuse [No. 12, located in the fuse block (J/B)]
- to the clutch interlock switch terminal 2.

With the clutch pedal depressed, power is supplied

- through the clutch interlock switch terminal 1
- to IPDM E/R terminal 35.

Ground is supplied at all times

- to IPDM E/R terminals 39 and 59
- through body grounds E9, E15 and E24.

If the IPDM E/R receives a starter relay request ON signal from the BCM over the CAN communication lines, the IPDM E/R grounds the starter relay and power is supplied

- through terminal 19 of the IPDM E/R
- to terminal S of the starter motor.

The starter motor magnetic switch energizes closing the circuit between the battery and the starter motor. The starter motor is case ground through the cylinder block. With power and ground supplied, the starter motor operates.

#### M/T Models with QR25DE

Power is supplied at all times

- through fusible link box (battery)
- to starter motor terminal B and
- through 40A fusible link (letter **m**, located in the fuse and fusible link box)
- to ignition switch terminal B.

With the ignition switch in the START position, power is supplied

- from ignition switch terminal ST
- to IPDM E/R terminal 21.

With the ignition switch in the ON or START position, power is supplied

- through 10A fuse [No. 12, located in the fuse block (J/B)]
- to clutch interlock switch terminal 2.

With the clutch pedal depressed, power is supplied

- through clutch interlock switch terminal 1
- to IPDM E/R terminal 35.

Ground is supplied at all times

- to IPDM E/R terminals 39 and 59
- through body grounds E9 and E15.

If the IPDM E/R receives a starter relay request ON signal from the BCM over the CAN communication lines, the IPDM E/R grounds the starter relay and power is supplied

- through terminal 19 of the IPDM E/R
- to terminal S of the starter motor.

The starter motor magnetic switch energizes closing the circuit between the battery and the starter motor. The starter motor is case ground through the cylinder block. With power and ground supplied, the starter motor operates.

#### CVT Models with MR20DE

Power is supplied at all times

- through 225A fusible link [letter **a**, located in the fusible link box (battery)]
- to starter motor terminal B, and
- through 40A fusible link (letter **m**, located in the fuse and fusible link box)

A

B

C

D

E

F

G

H

I

J

SC

L

M

N

O

P

# STARTING SYSTEM

## < SERVICE INFORMATION >

---

- to ignition switch terminal B.

With the ignition switch in the START position, power is supplied

- from ignition switch terminal ST
- to IPDM E/R terminal 21.

With the ignition switch in the ON or START position, power is supplied

- through 10A fuse [No. 12, located in the fuse block (J/B)]
- to transmission range switch terminal 7.

With the shift selector in the P or N position, power is supplied

- through transmission range switch terminal 6
- to IPDM E/R terminal 35.

Ground is supplied at all times

- to IPDM E/R terminals 39 and 59
- through body grounds E9, E15 and E24.

If the IPDM E/R receives a starter relay request ON signal from the BCM over the CAN communication lines, the IPDM E/R grounds the starter relay and power is supplied

- through terminal 19 of the IPDM E/R
- to terminal S of the starter motor.

The starter motor magnetic switch energizes closing the circuit between the battery and the starter motor. The starter motor is case ground through the cylinder block. With power and ground supplied, the starter motor operates.

### CVT Models with QR25DE

Power is supplied at all times

- through fusible link box (battery)
- to starter motor terminal B, and
- through 40A fusible link (letter **m**, located in the fuse and fusible link box)
- to ignition switch terminal B.

With the ignition switch in the START position, power is supplied

- from ignition switch terminal ST
- to IPDM E/R terminal 21.

With the ignition switch in the ON or START position, power is supplied

- through 10A fuse [No. 12, located in the fuse block (J/B)]
- to transmission range switch terminal 7.

With the shift selector in the P or N position, power is supplied

- through transmission range switch terminal 6
- to IPDM E/R terminal 35.

Ground is supplied at all times

- to IPDM E/R terminals 39 and 59
- through body grounds E9 and E15.

If the IPDM E/R receives a starter relay request ON signal from the BCM over the CAN communication lines, the IPDM E/R grounds the starter relay and power is supplied

- through terminal 19 of the IPDM E/R
- to terminal S of the starter motor.

The starter motor magnetic switch energizes closing the circuit between the battery and the starter motor. The starter motor is case ground through the cylinder block. With power and ground supplied, the starter motor operates.

# STARTING SYSTEM

< SERVICE INFORMATION >

## Wiring Diagram - START -

INFOID:00000006152137

M/T Models - MR20DE

### SC-START-01

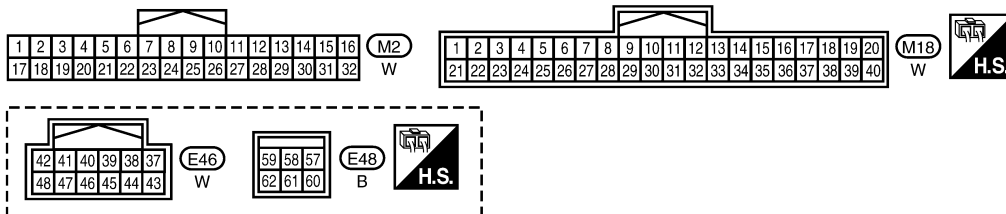
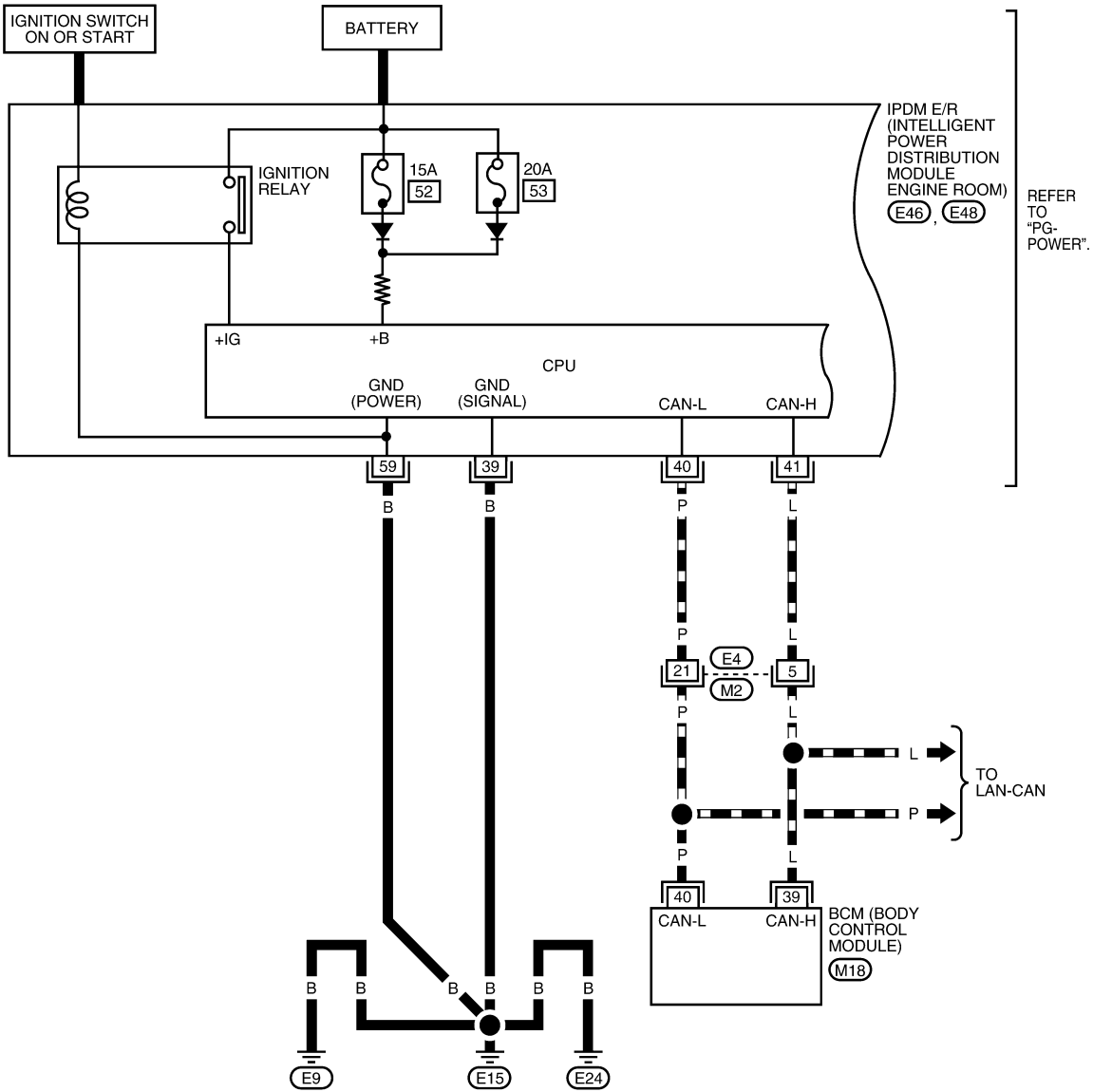

WKWA5772E

# STARTING SYSTEM

< SERVICE INFORMATION >

SC-START-02

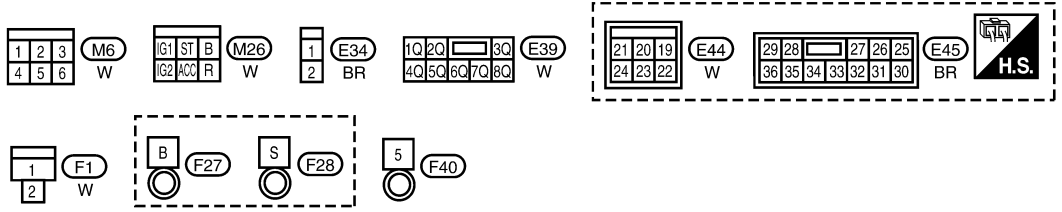
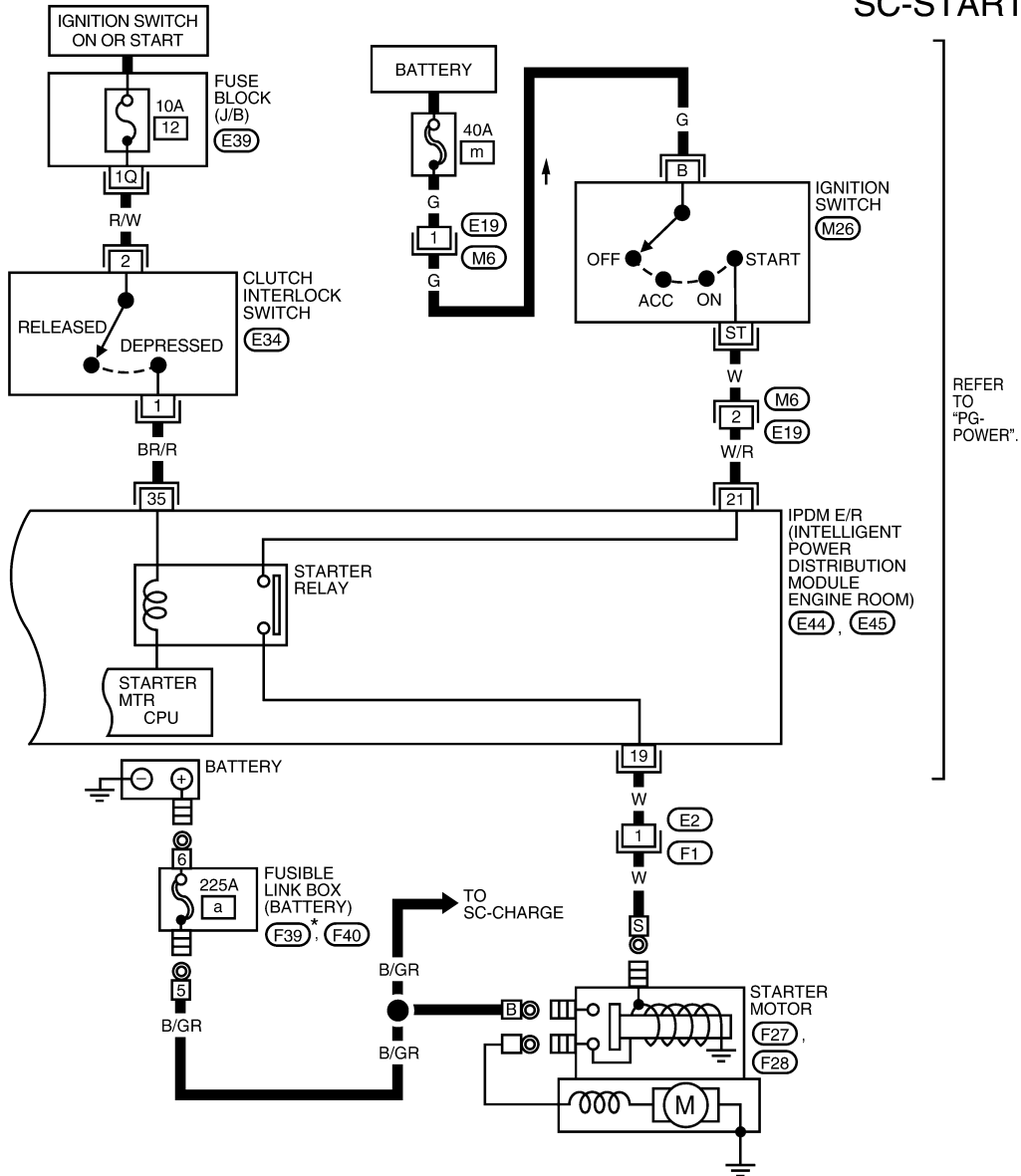

\* : (F39) IS AN INTEGRAL PART OF FUSIBLE LINK BOX (BATTERY) ASSEMBLY

BKWA0739E

# STARTING SYSTEM

< SERVICE INFORMATION >

M/T Models - QR25DE

SC-START-03

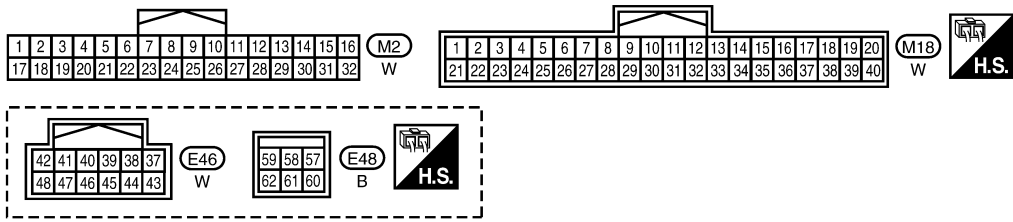
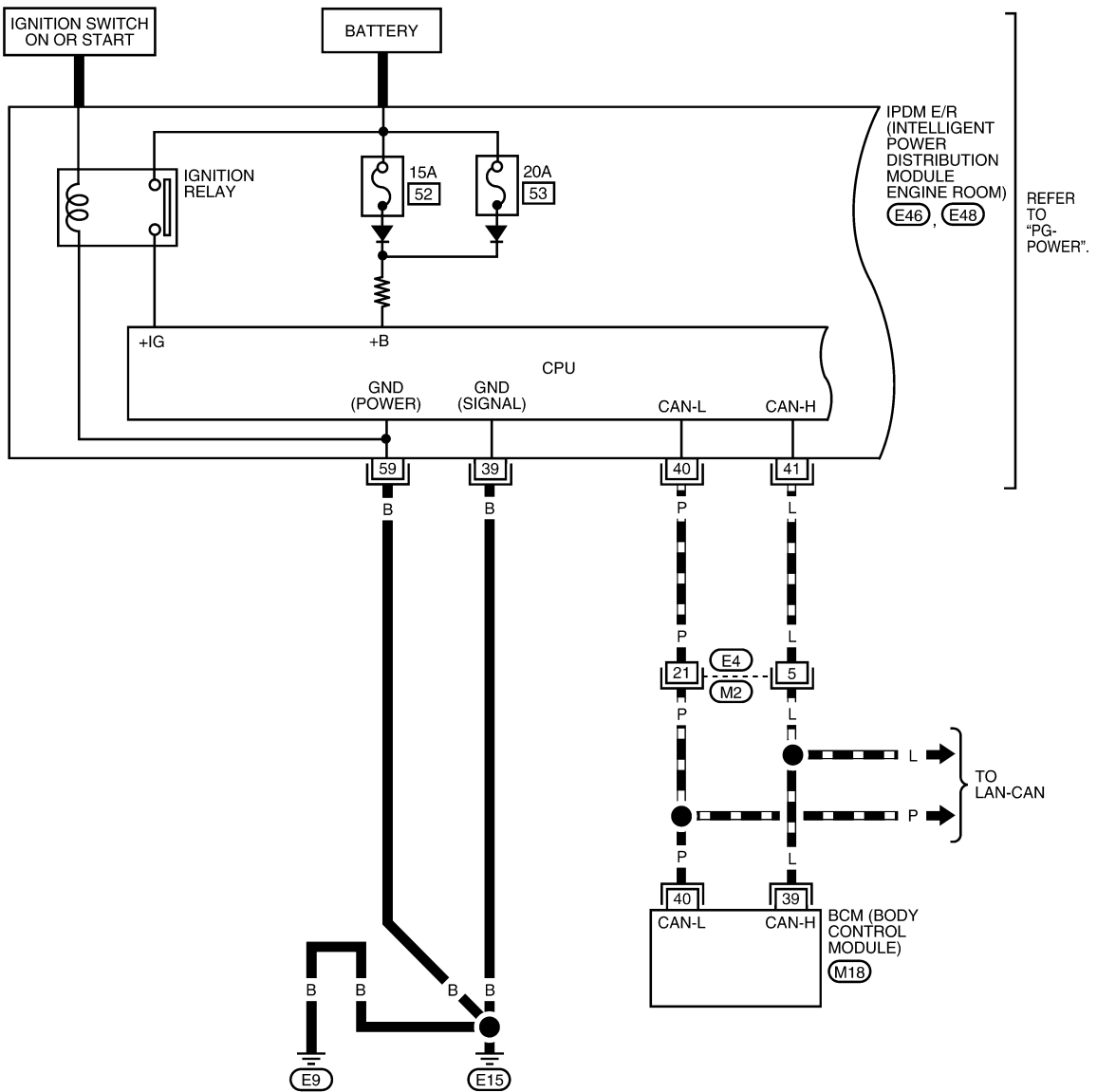

WKWA5773E

# STARTING SYSTEM

< SERVICE INFORMATION >

SC-START-04

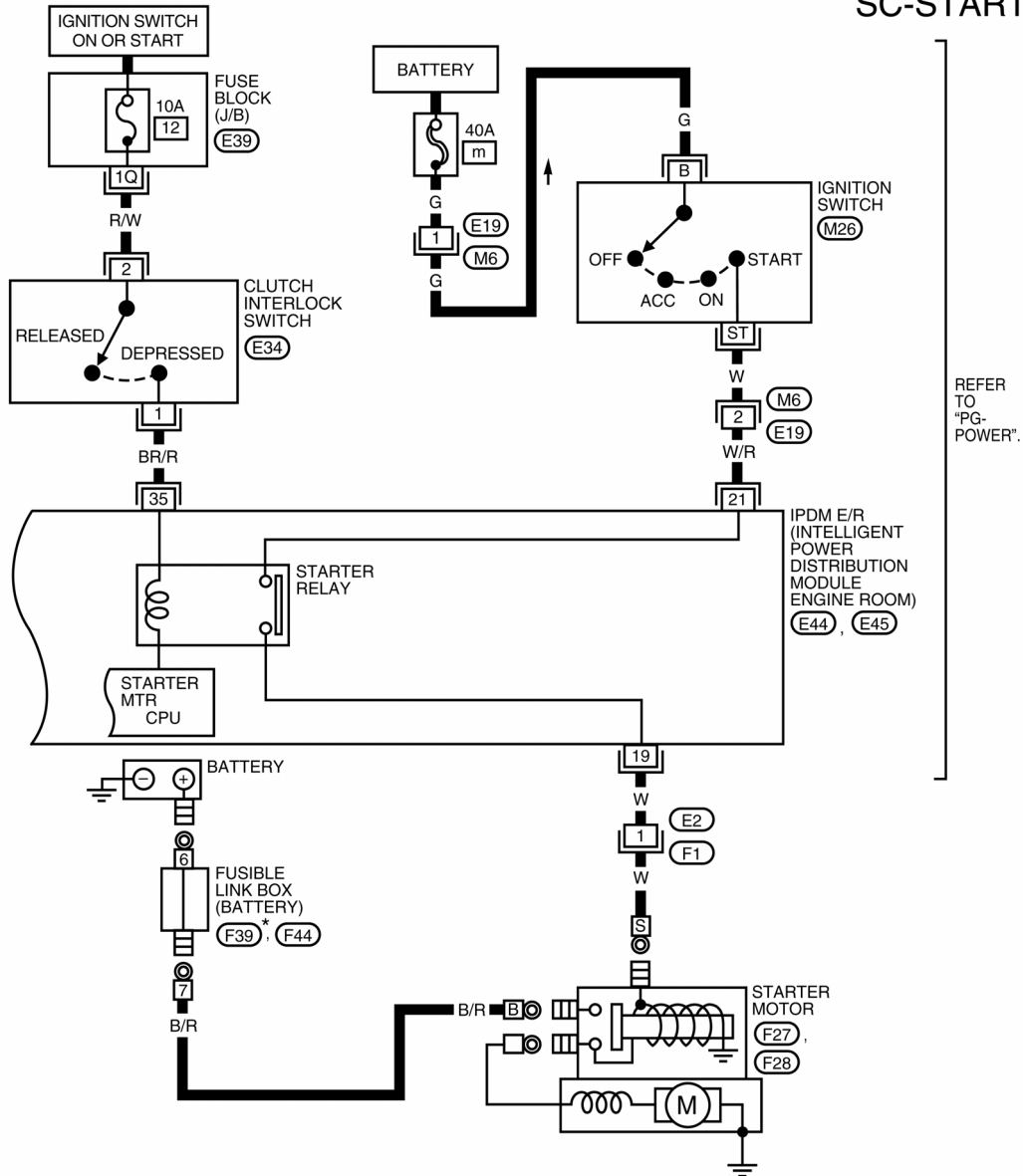

REFER TO "PG-POWER".

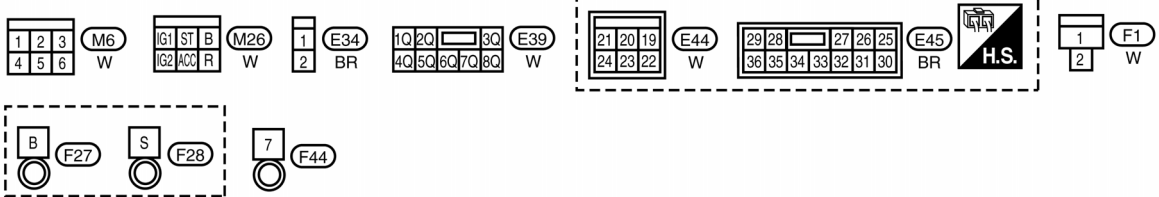

\* : (F39) IS AN INTEGRAL PART OF FUSIBLE LINK BOX (BATTERY) ASSEMBLY

WKWA5774E



# STARTING SYSTEM

< SERVICE INFORMATION >

CVT Models - MR20DE

SC-START-05

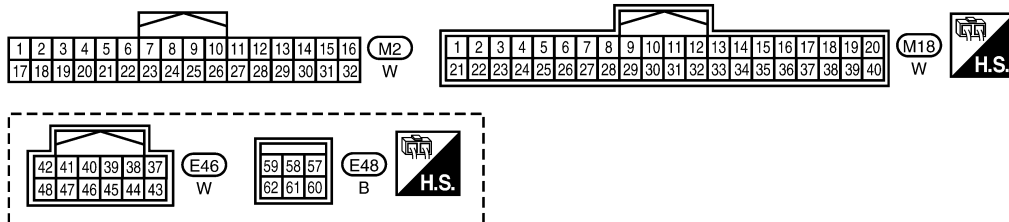
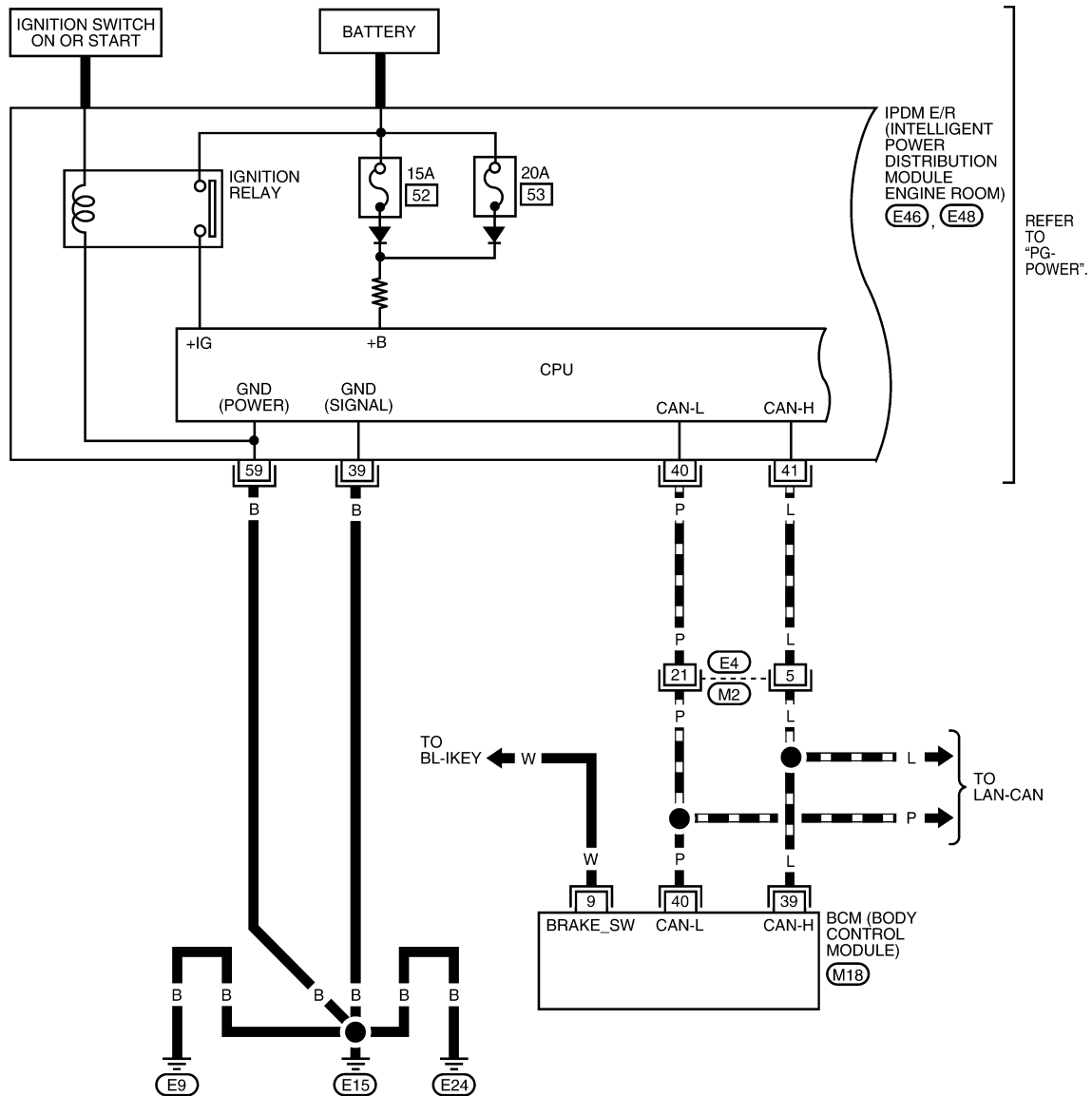

WKWA5775E

# STARTING SYSTEM

< SERVICE INFORMATION >

SC-START-06

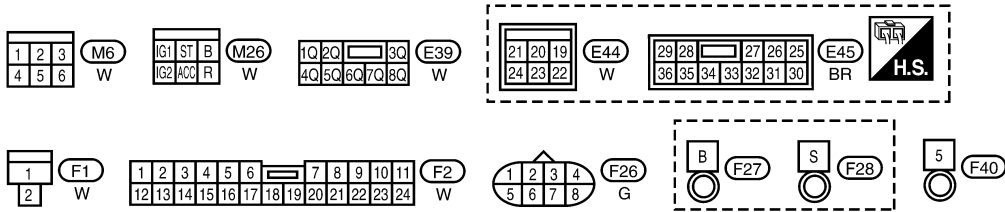
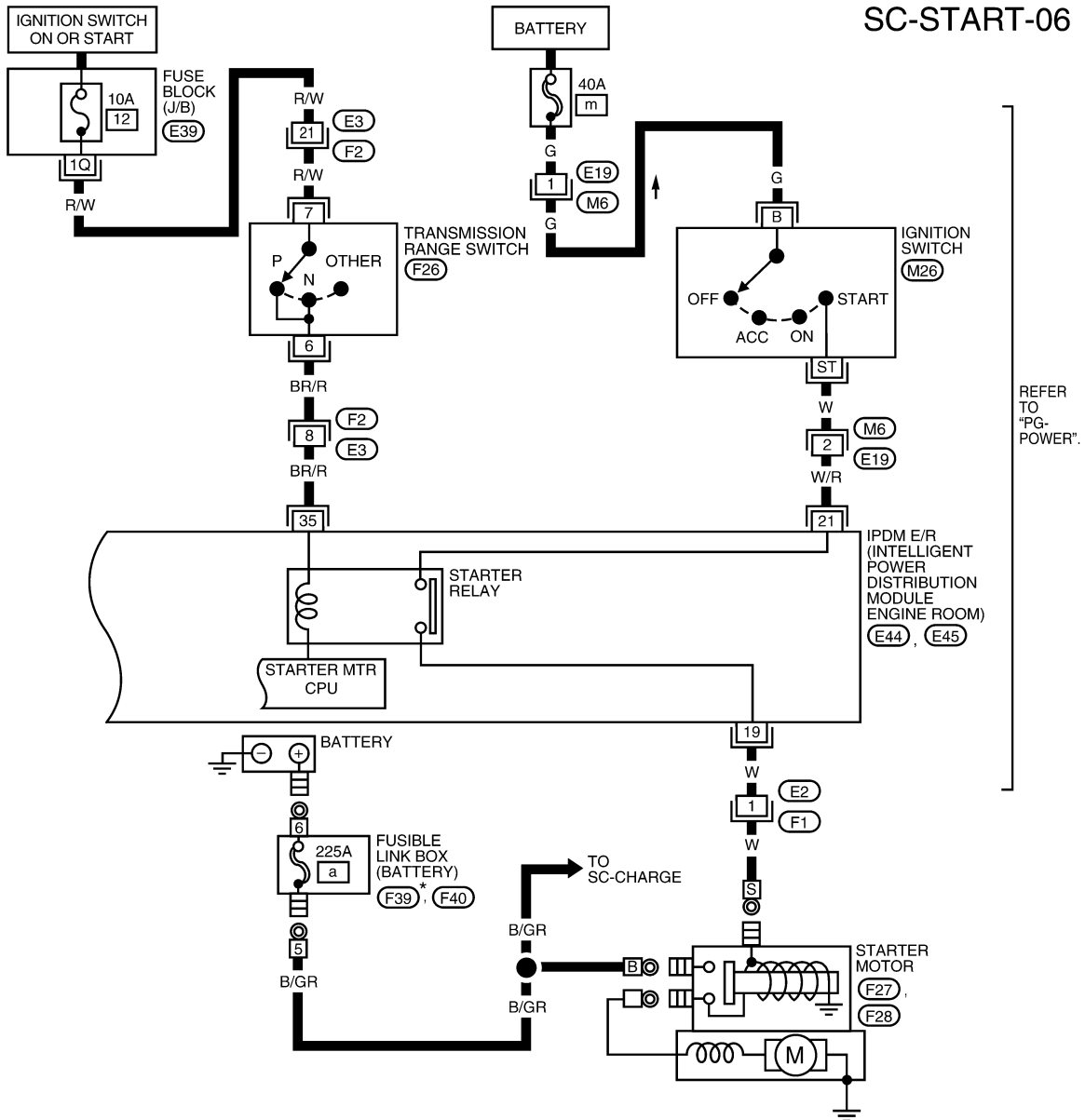

\* : (F39) IS AN INTEGRAL PART OF FUSIBLE LINK BOX (BATTERY) ASSEMBLY

ABBWA0641GB

# STARTING SYSTEM

< SERVICE INFORMATION >

CVT Models - QR25DE

SC-START-07

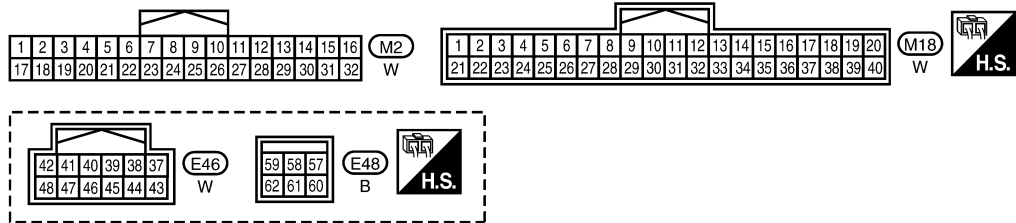
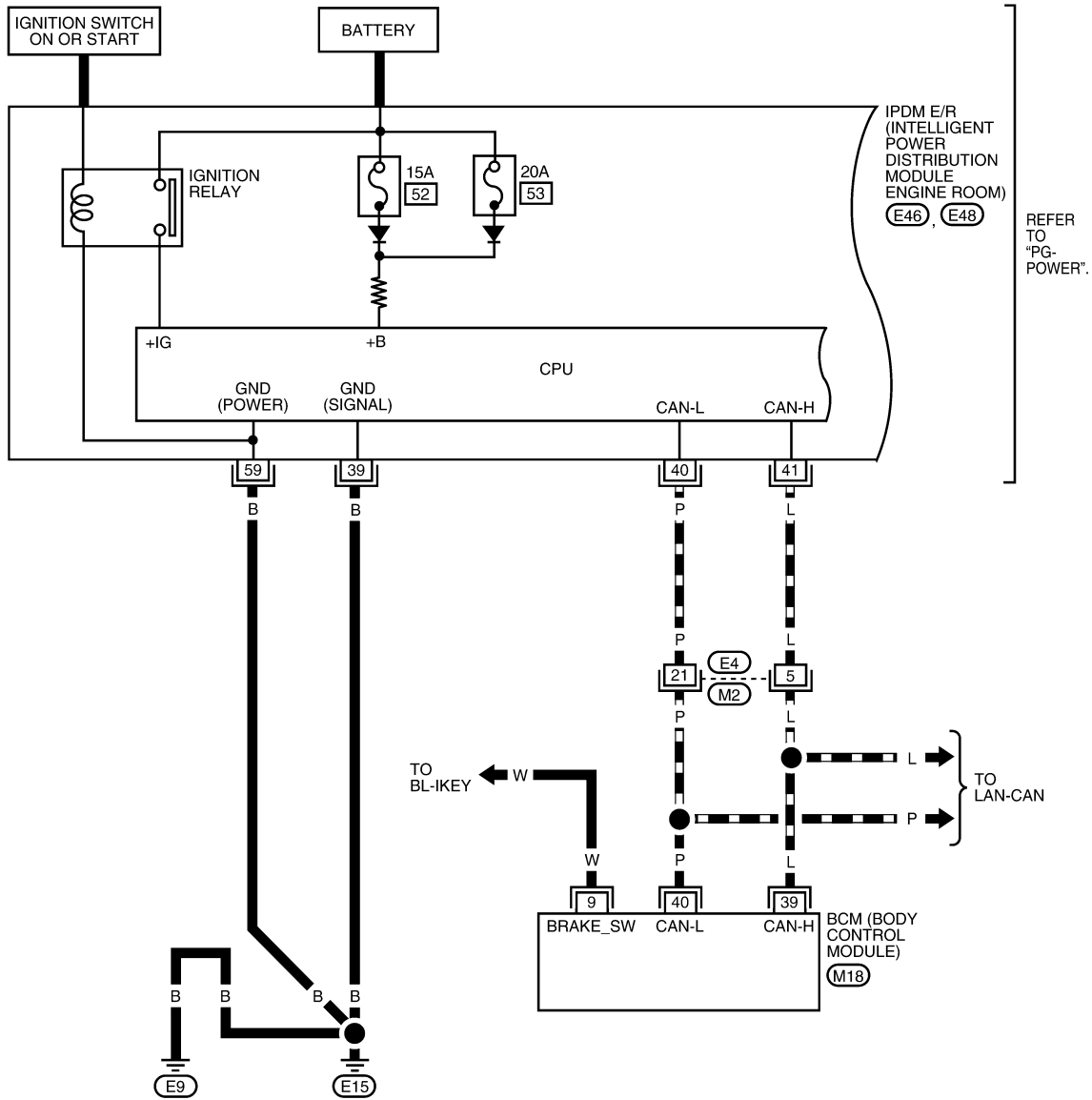

WKWA5777E

# STARTING SYSTEM

< SERVICE INFORMATION >

SC-START-08

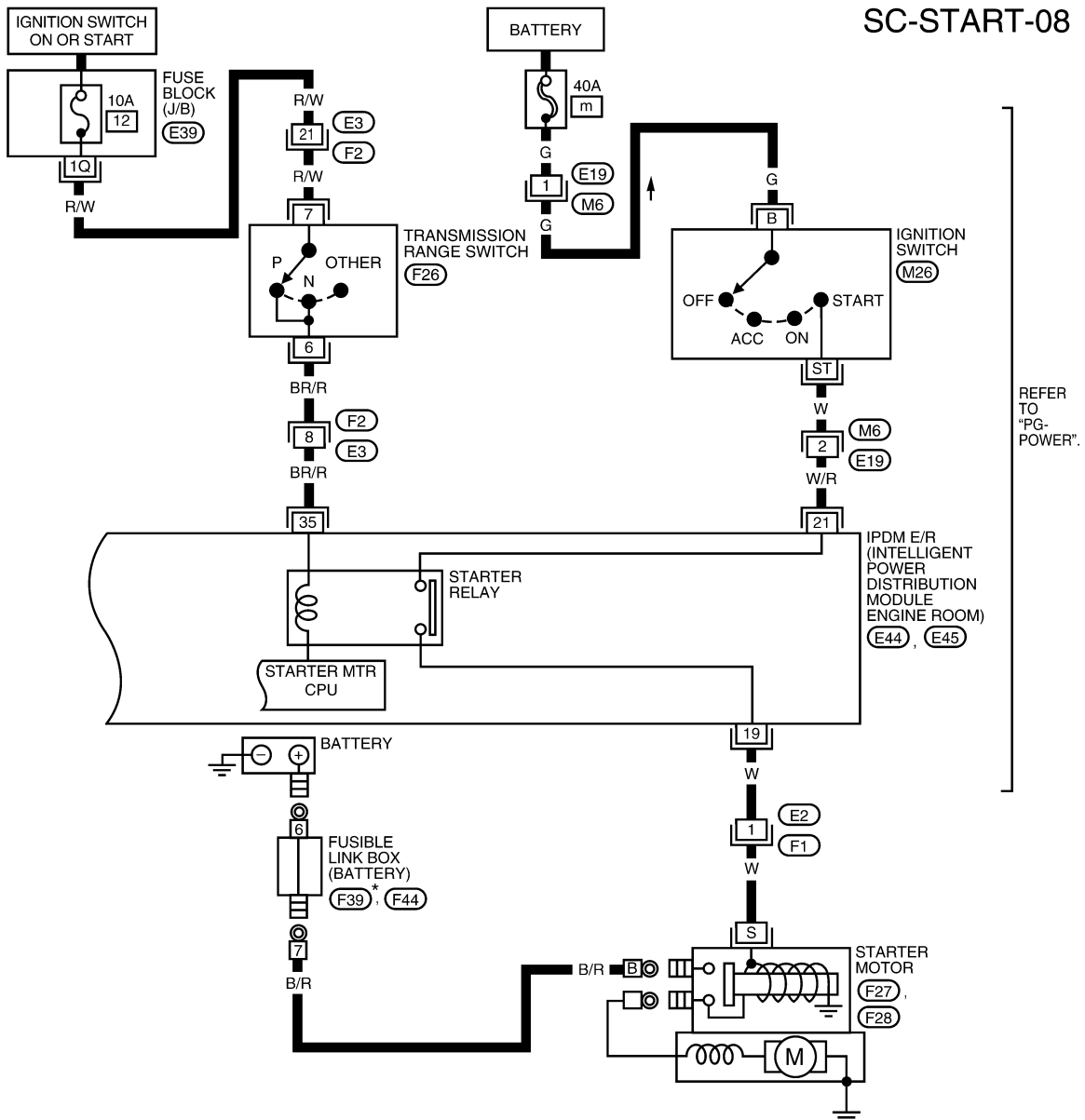

REFER TO "PG-POWER".

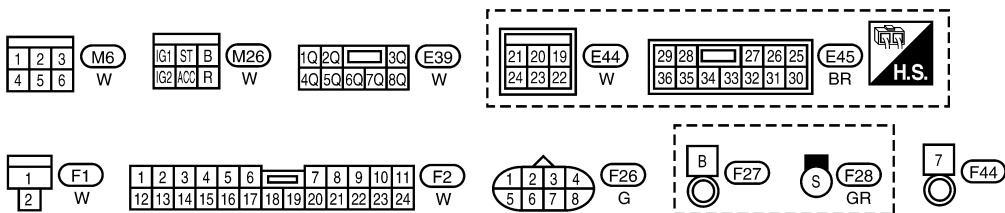

\* : (F39) IS AN INTEGRAL PART OF FUSIBLE LINK BOX (BATTERY) ASSEMBLY

ABBWA0642GB

## Trouble Diagnosis with Multitasking Battery Diagnostic Station (Starting)

INFOID:000000006152138

Perform the starting system test with multitasking battery diagnostic station. For details and operating instructions, refer to diagnostic station instruction manual.

# STARTING SYSTEM

< SERVICE INFORMATION >

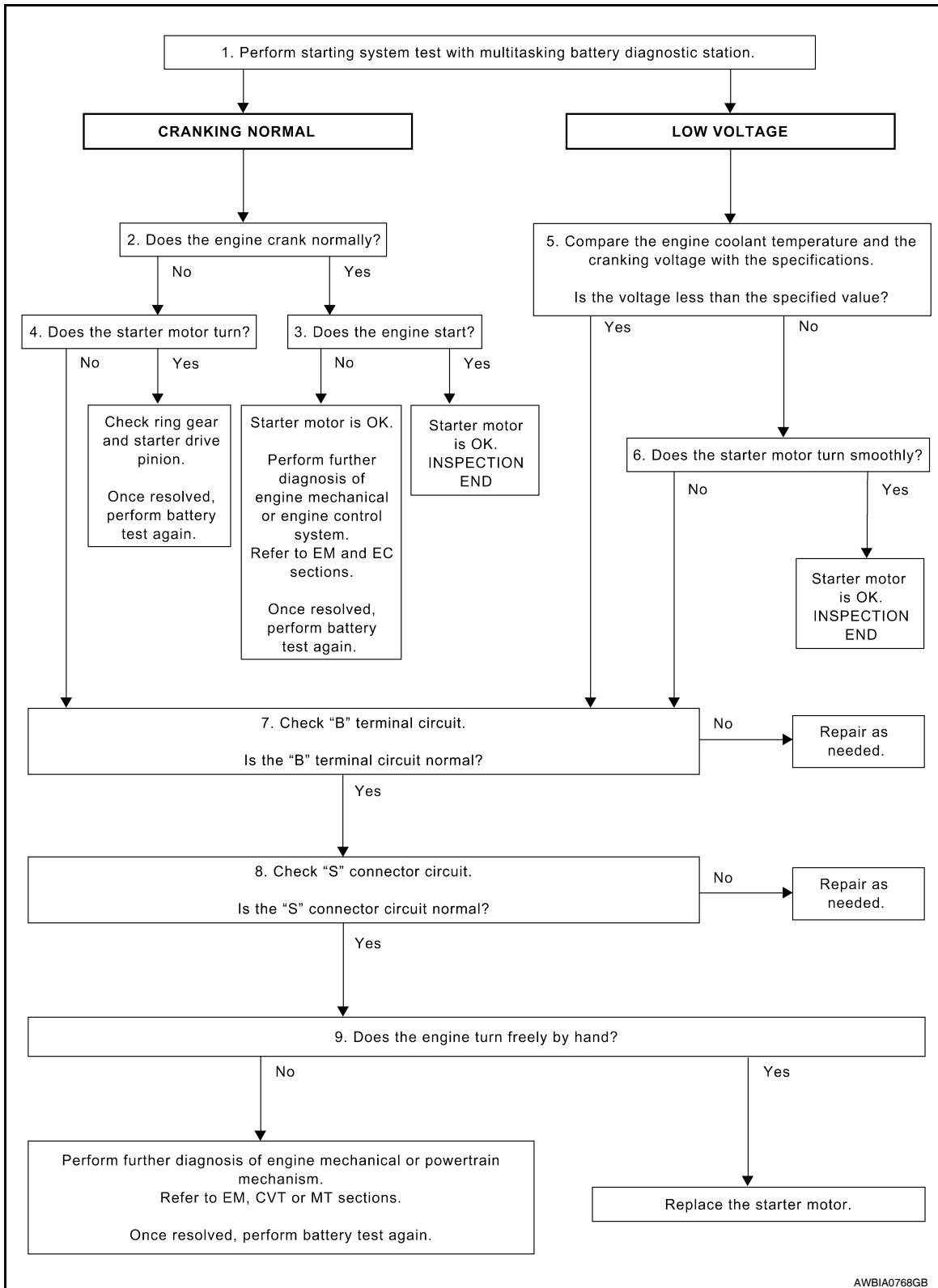

## DIAGNOSTIC PROCEDURE 1

Check Starter Motor Circuit

### 1. CHECK POWER SUPPLY TO STARTER MOTOR

1. Remove the fuel pump fuse.

A  
B  
C  
D  
E  
F  
G  
H  
I  
J  
SC  
L  
M  
N  
O  
P

# STARTING SYSTEM

## < SERVICE INFORMATION >

2. Crank or start the engine (where possible) until the fuel pressure is released.
3. Turn the ignition switch OFF.
4. Check that the starter motor connector F27 connection is clean and tight.
5. Check voltage between starter motor connector F27 terminal B and ground using a digital circuit tester.

### Battery voltage should exist

#### OK or NG

- OK >> GO TO 2.  
NG >> Check harness between the battery and the starter motor for open circuit.

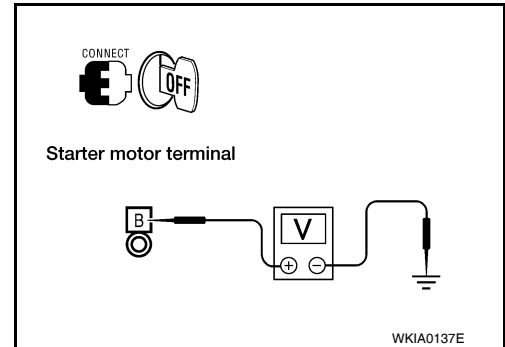

## 2.CHECK VOLTAGE DROP ON STARTER MOTOR CIRCUIT

Check voltage between starter motor connector F27 terminal B and battery positive terminal using a digital circuit tester.

### Ignition switch in START : Less than 0.2V

#### OK or NG

- OK >> GO TO 3.  
NG >> Check harness between the battery and the starter motor for poor continuity.

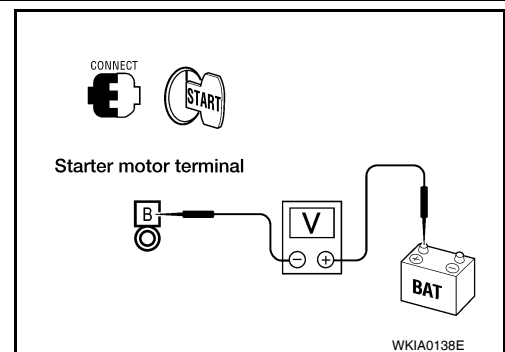

## 3.CHECK VOLTAGE DROP ON STARTER MOTOR GROUND CIRCUIT

Check voltage between starter motor case and battery negative terminal using a digital circuit tester.

### Ignition switch in START : Less than 0.2V

#### OK or NG

- OK >> Starter motor ground circuit is OK. Further inspection is necessary. Refer to "Trouble Diagnoses with Multitasking Battery Diagnostic Station (Starting)".
- NG >> Check harness between the starter motor case and ground for poor continuity.

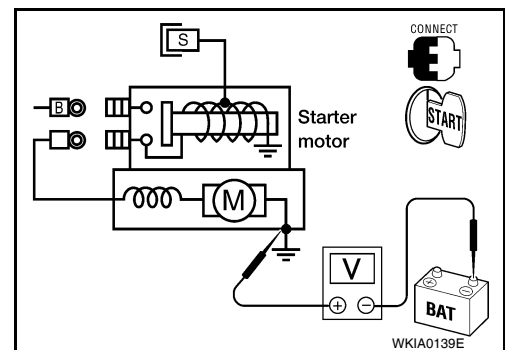

## DIAGNOSTIC PROCEDURE 2

Check Magnetic Switch Circuit

## 1.CHECK POWER SUPPLY TO MAGNETIC SWITCH

1. Remove the fuel pump fuse.
2. Crank or start the engine (where possible) until the fuel pressure is released.
3. Turn the ignition switch OFF.
4. Disconnect starter motor connector F28.

# STARTING SYSTEM

## < SERVICE INFORMATION >

- Check voltage between starter motor connector F28 terminal S and ground using a digital circuit tester.

**Ignition switch in START : Battery voltage**

### OK or NG

- OK >> GO TO 2.
- NG >> Check the following:
- 40A fusible link (letter **m**, located in the fuse and fusible link box)
  - 10A fuse [No. 12, located in the fuse block (J/B)]
  - 15A fuse (No. 52, located in the IPDM E/R)
  - 20A fuse (No. 53, located in the IPDM E/R)
  - Transmission range switch (CVT models) or clutch interlock switch (M/T models)
  - Ignition switch
  - Ignition relay (IPDM E/R)
  - Starter relay (IPDM E/R)
  - Starter relay request ON signal from BCM
  - Harness for open or short circuit

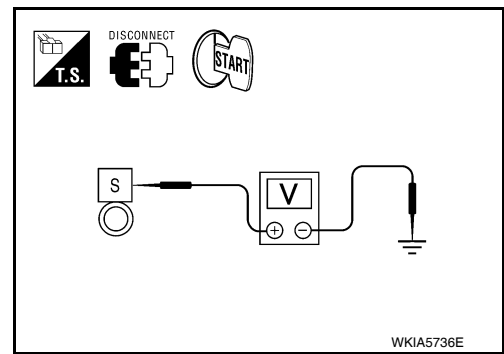

## 2. CHECK VOLTAGE DROP ON MAGNETIC SWITCH CIRCUIT

- Connect starter motor connector F28.
- Check voltage between starter motor connector F28 terminal S and battery positive terminal using a digital circuit tester.

**Ignition switch in START : Less than 1V**

### OK or NG

- OK >> Magnetic switch circuit is OK. Further inspection is necessary. Refer to "Trouble Diagnoses with Multitasking Battery Diagnostic Station (Starting)".
- NG >> Check harness, components and connections between the battery and the magnetic switch for poor continuity.

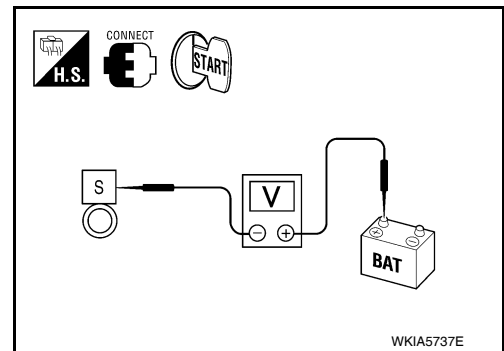

## MINIMUM SPECIFICATION OF CRANKING VOLTAGE REFERENCING COOLANT TEMPERATURE

Engine coolant temperature	Voltage V
-30°C to -20°C (-22°F to -4°F)	8.4
-19°C to -10°C (-2°F to 14°F)	8.9
-9°C to 0°C (16°F to 32°F)	9.3
More than 1°C (More than 34°F)	9.7





# STARTING SYSTEM

## < SERVICE INFORMATION >

1. "S" terminal harness
2. Starter motor
3. "B" terminal

### M/T Models

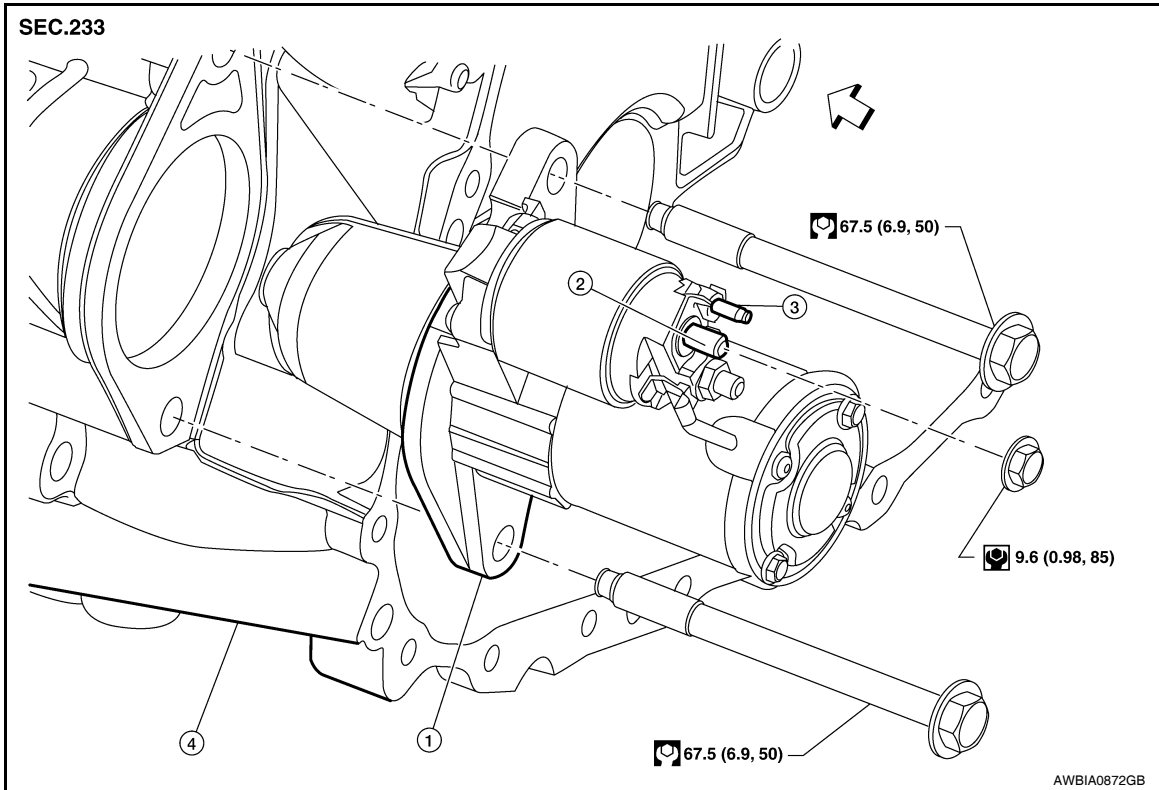

1. Starter motor
  2. "B" terminal
  3. "S" terminal
  4. Transaxle assembly
- ↔ Engine front

## REMOVAL

1. Disconnect the battery negative terminal. Refer to [SC-8. "Removal and Installation \(QR25DE Battery\)"](#).
2. Raise vehicle.
3. Disconnect "S" terminal connector.
4. Remove "B" terminal nut.
5. Remove starter motor bolts.
6. Remove starter motor.

## INSTALLATION

Installation is in the reverse order of removal.

### **CAUTION:**

**Be sure to tighten "B" terminal nut carefully.**

# CHARGING SYSTEM

< SERVICE INFORMATION >

---

## CHARGING SYSTEM

### System Description

INFOID:000000006152141

The generator provides DC voltage to operate the vehicle's electrical system and to keep the battery charged.

The voltage output is controlled by the IC regulator.

Power is supplied at all times to generator terminal 3 through

- 10A fuse [No. 26, located in the fuse block (J/B)].

Power is supplied through terminal 1 to charge the battery and operate the vehicle's electrical system. Output voltage is monitored at terminal 3 by the IC regulator. The charging circuit is protected by the 225A fusible link [letter **a**, located in the fusible link box (battery)].

Ground is supplied

- to generator terminal 5
- through body ground F5 (MR20DE)
- through body ground E62 (QR25DE) and
- through the generator case to the cylinder block

With the ignition switch in the ON or START position, power is supplied

- through 10A fuse [No. 14, located in the fuse block (J/B)]
- to combination meter terminal 2 for the charge warning lamp.

The IC regulator controls ground to terminal 32 of the combination meter through terminal 2 of the generator.

When the ignition is turned on and power becomes available at terminal 2, this "wakes up" the regulator. The regulator monitors charge output and grounds terminal 2 or leaves it open depending on charge output. With power and ground supplied, the charge warning lamp will illuminate. When the generator is providing sufficient voltage, the ground is opened and the charge warning lamp will go off.

If the charge warning lamp illuminates with the engine running, a malfunction is indicated.

# CHARGING SYSTEM

< SERVICE INFORMATION >

## Wiring Diagram - CHARGE -

INFOID:000000006152142

MR20DE

### SC-CHARGE-01

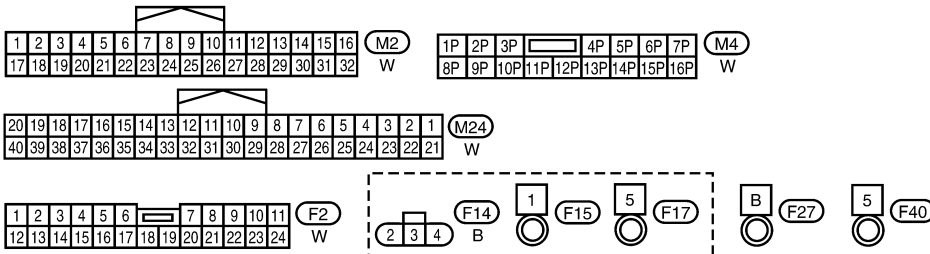
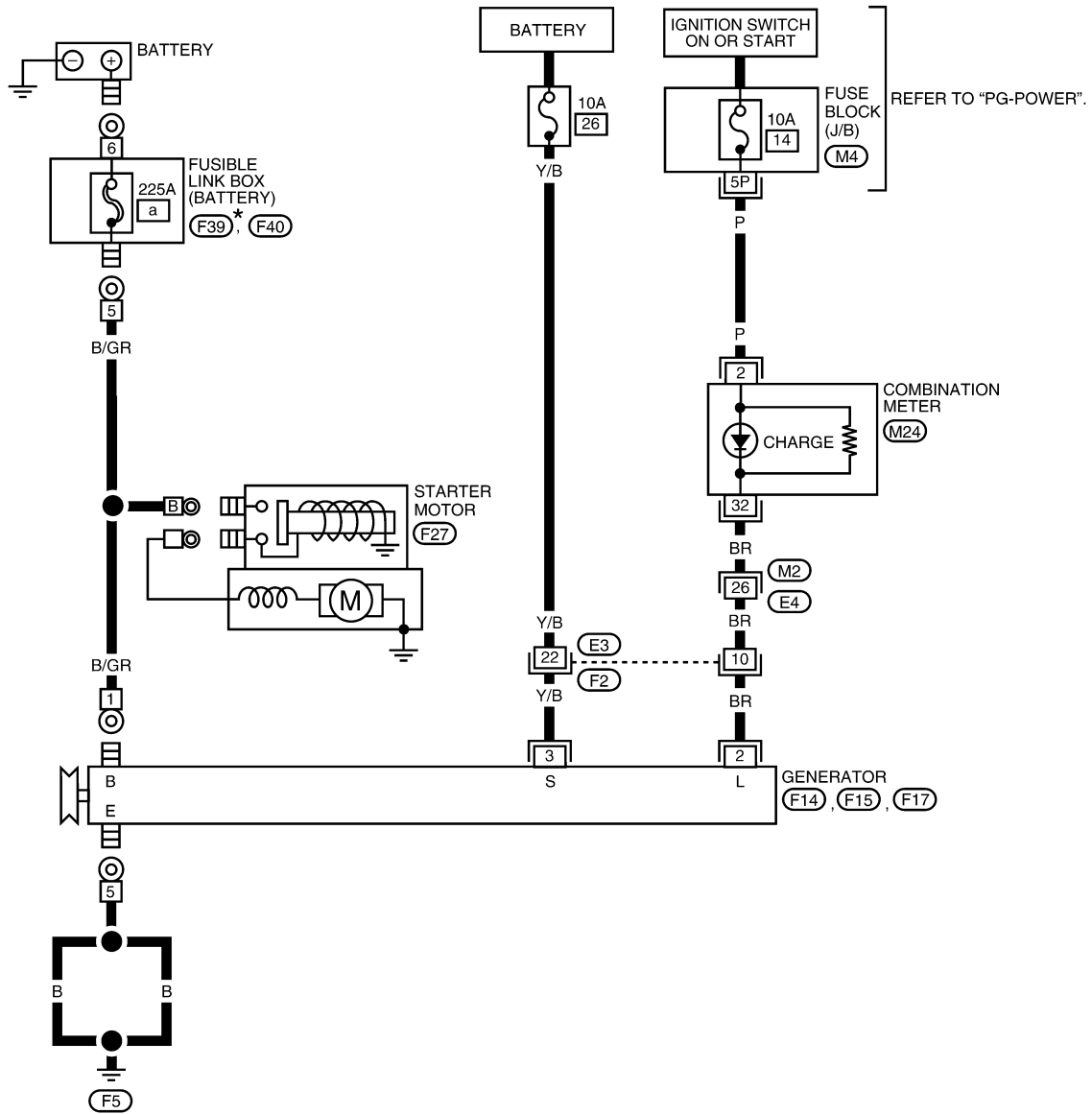

\*: (F39) IS AN INTEGRAL PART OF FUSIBLE LINK BOX (BATTERY) ASSEMBLY

AAMWA0189GB

# CHARGING SYSTEM

< SERVICE INFORMATION >

QR25DE

SC-CHARGE-02

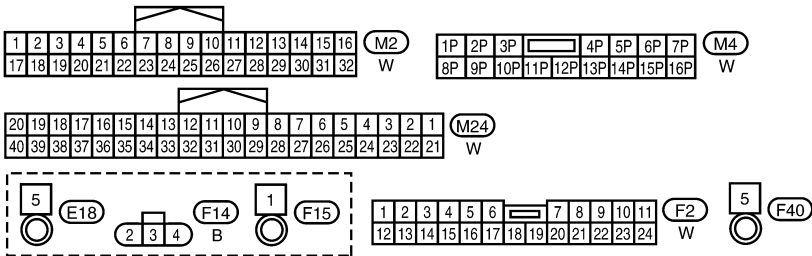
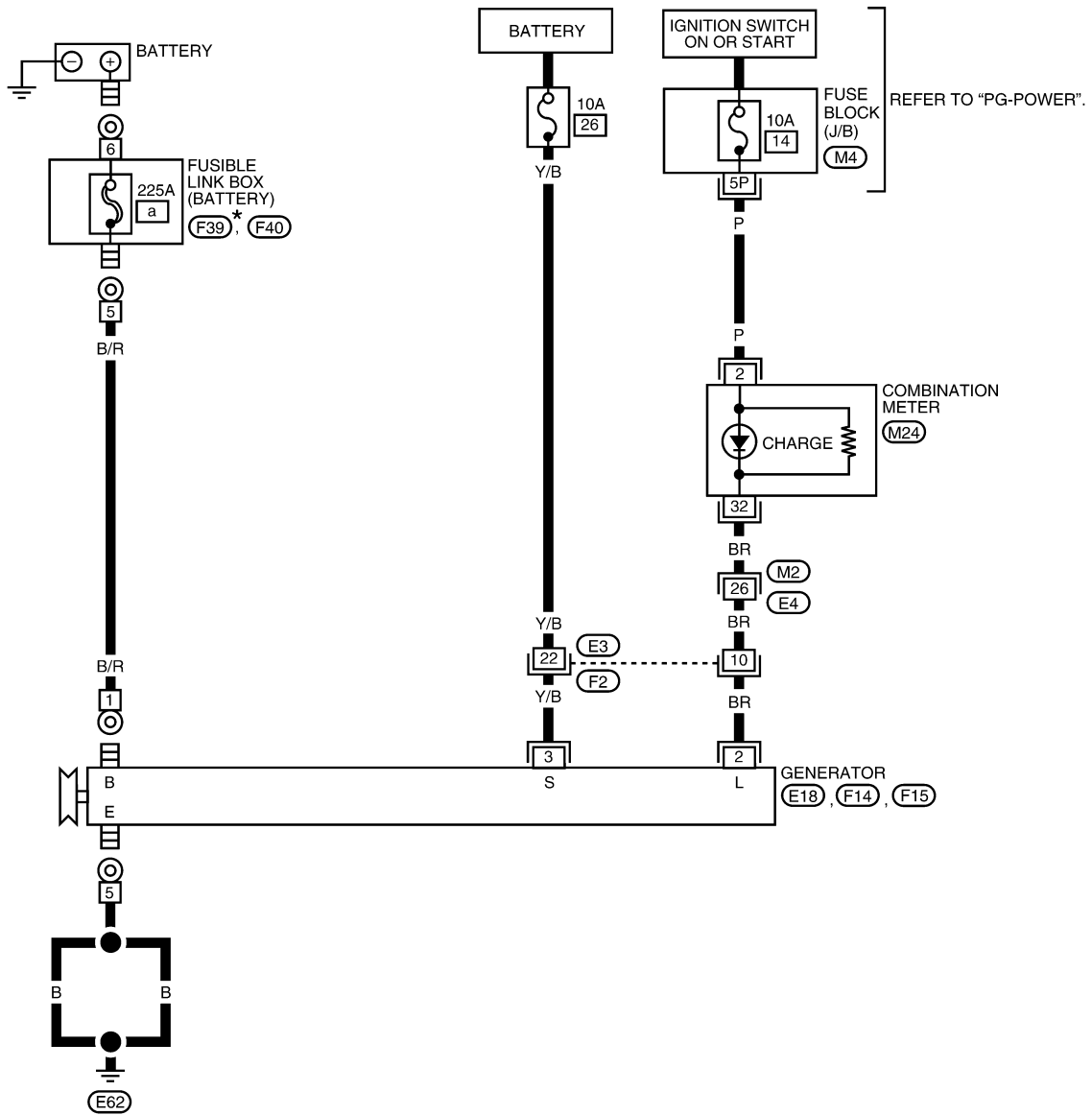

\*: (F39) IS AN INTEGRAL PART OF FUSIBLE LINK BOX (BATTERY) ASSEMBLY

AAMWA0190GB

# CHARGING SYSTEM

< SERVICE INFORMATION >

## Trouble Diagnosis with Multitasking Battery Diagnostic Station (Charging) INFOID:000000006152143

Perform the charging system test with multitasking battery diagnostic station. For details and operating instructions, refer to diagnostic station instruction manual.

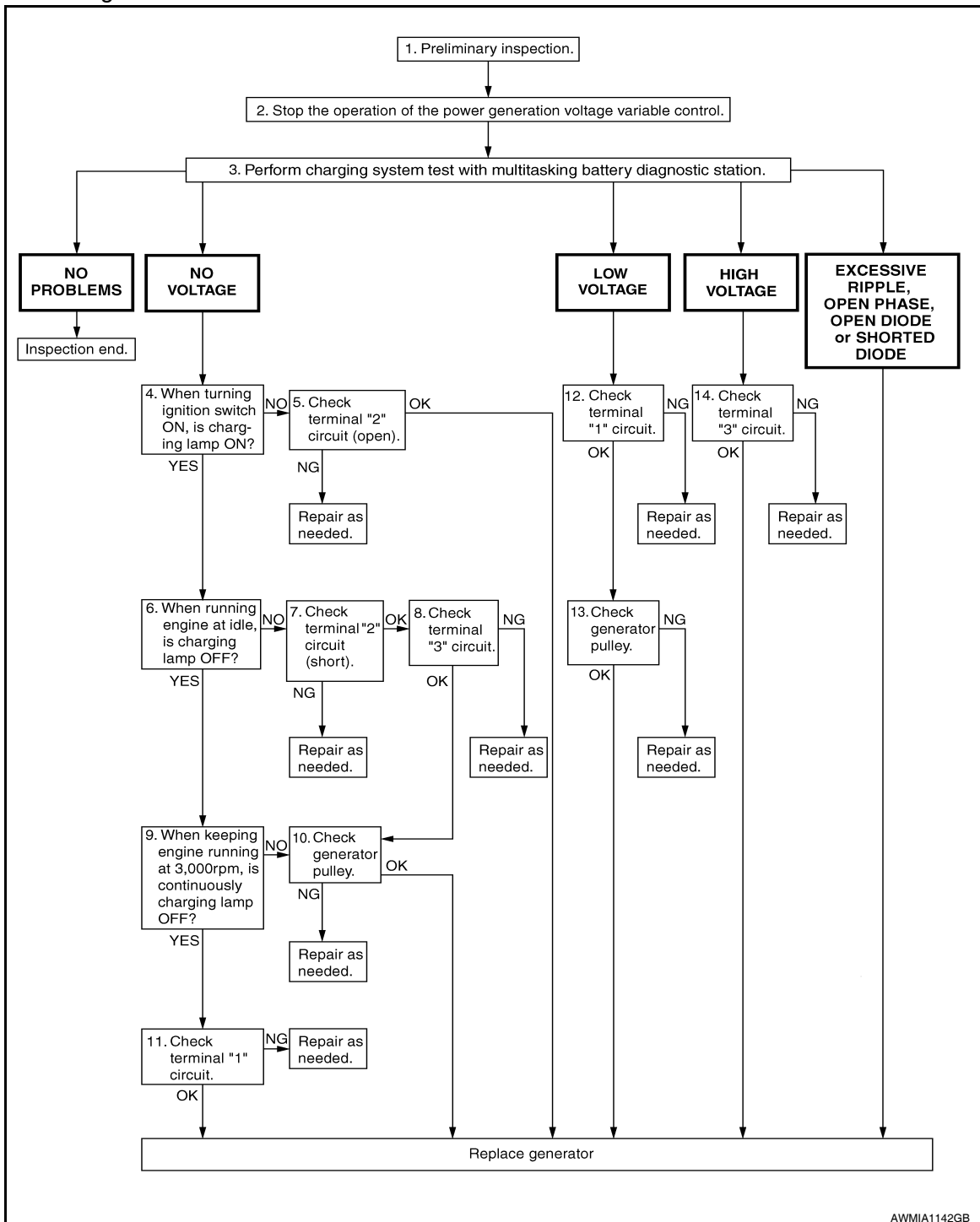

### DIAGNOSTIC PROCEDURE 1

Check Charge Warning Lamp Circuit

#### 1. CHECK CHARGE WARNING LAMP CIRCUIT CONNECTION

Check to see if terminal 2 is clean and tight.

OK or NG

# CHARGING SYSTEM

## < SERVICE INFORMATION >

- OK >> GO TO 2.  
NG >> Repair terminal 2 connection. Confirm repair by performing complete Starting/Charging system test. Refer to diagnostic station instruction manual.

## 2.CHECK CHARGE WARNING LAMP CIRCUIT

1. Disconnect generator connector F14.
2. Apply ground to generator connector F14 terminal 2 with the ignition switch in the ON position.

**CHARGE lamp should light up.**

### OK or NG

- OK >> GO TO "Trouble Diagnoses with Multitasking Battery Diagnostic Station (Charging)".
- NG >> Check the following.
- 10A fuse [No. 14, located in fuse block (J/B)]
  - CHARGE lamp
  - Harness for open or short between combination meter and fuse
  - Harness for open or short between combination meter and generator

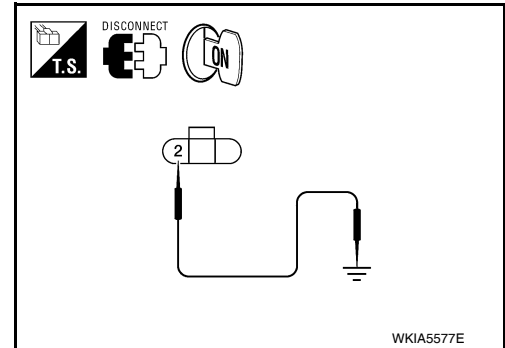

## DIAGNOSTIC PROCEDURE 2

Check Battery Circuit

## 1.CHECK BATTERY CIRCUIT CONNECTION

Check to see if connector F15 terminal 1 is clean and tight.

### OK or NG

- OK >> GO TO 2.  
NG >> Repair connector F15 terminal 1 connection. Confirm repair by performing complete Starting/Charging system test. Refer to diagnostic station instruction manual.

## 2.CHECK BATTERY CIRCUIT

Check voltage between generator connector F15 terminal 1 and ground using a digital circuit tester.

**Battery voltage should exist.**

### OK or NG

- OK >> GO TO 3.  
NG >> Check the following.
- 225A fusible link [letter **a**, located in fusible link box (battery)]
  - Harness for open or short between generator and fusible link

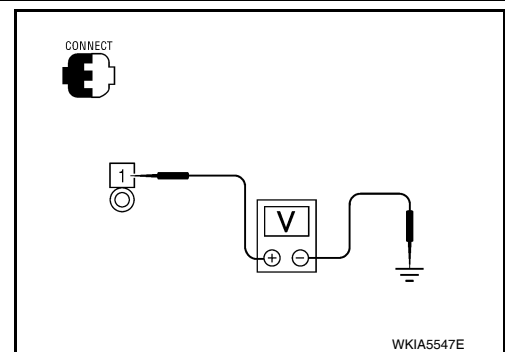

## 3.CHECK VOLTAGE DROP ON BATTERY CIRCUIT

Check voltage between generator connector F15 terminal 1 and battery positive terminal using a digital circuit tester.

**With engine running : Less than 0.2V  
at idle and warm**

### OK or NG

- OK >> Replace the generator. Refer to [SC-32. "Removal and Installation MR20DE"](#). Confirm repair by performing complete Starting/Charging system test. Refer to diagnostic station instruction manual.
- NG >> Check harness between the battery and the generator for poor continuity.

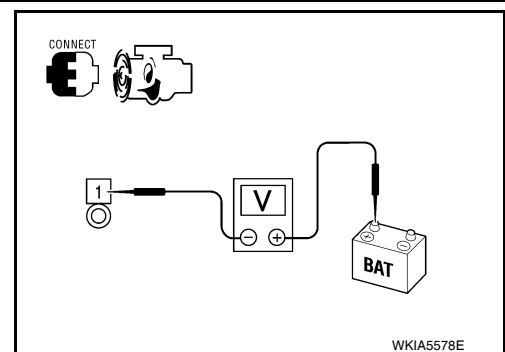

# CHARGING SYSTEM

< SERVICE INFORMATION >

## DIAGNOSTIC PROCEDURE 3

Check Voltage Regulator Circuit

### 1. CHECK VOLTAGE REGULATOR CIRCUIT CONNECTION

Check to see if connector F14 terminal 3 is clean and tight.

OK or NG

OK >> GO TO 2.

NG >> Repair connector F14 terminal 3 connection. Confirm repair by performing complete Starting/Charging system test. Refer to diagnostic station instruction manual.

### 2. CHECK VOLTAGE REGULATOR CIRCUIT

Check voltage between generator connector F14 terminal 3 and ground using a digital circuit tester.

**Battery voltage should exist.**

OK or NG

OK >> GO TO 3.

NG >> Check the following.

- 10A fuse [No. 26, located in fuse block (J/B)]
- Harness for open or short between generator and fuse

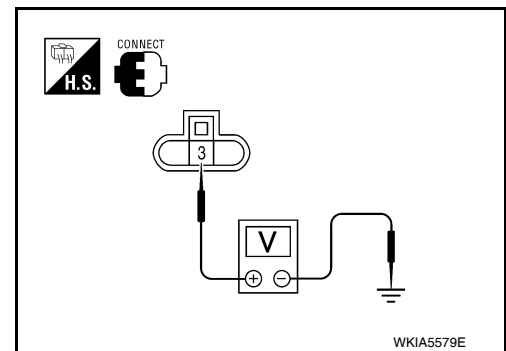

### 3. CHECK VOLTAGE DROP ON VOLTAGE REGULATOR CIRCUIT

Check voltage between generator connector F14 terminal 3 and battery positive terminal using a digital circuit tester.

**With engine running : Less than 0.2V  
at idle and warm**

OK or NG

OK >> Replace the generator. Refer to [SC-32, "Removal and Installation MR20DE"](#). Confirm repair by performing complete Starting/Charging system test. Refer to diagnostic station instruction manual.

NG >> Check harness between the battery and the generator for poor continuity.

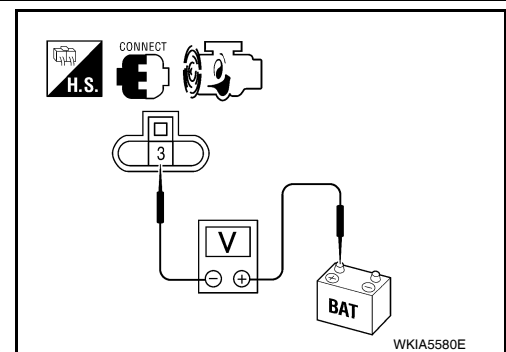

# CHARGING SYSTEM

< SERVICE INFORMATION >

## Removal and Installation MR20DE

INFOID:000000006152144

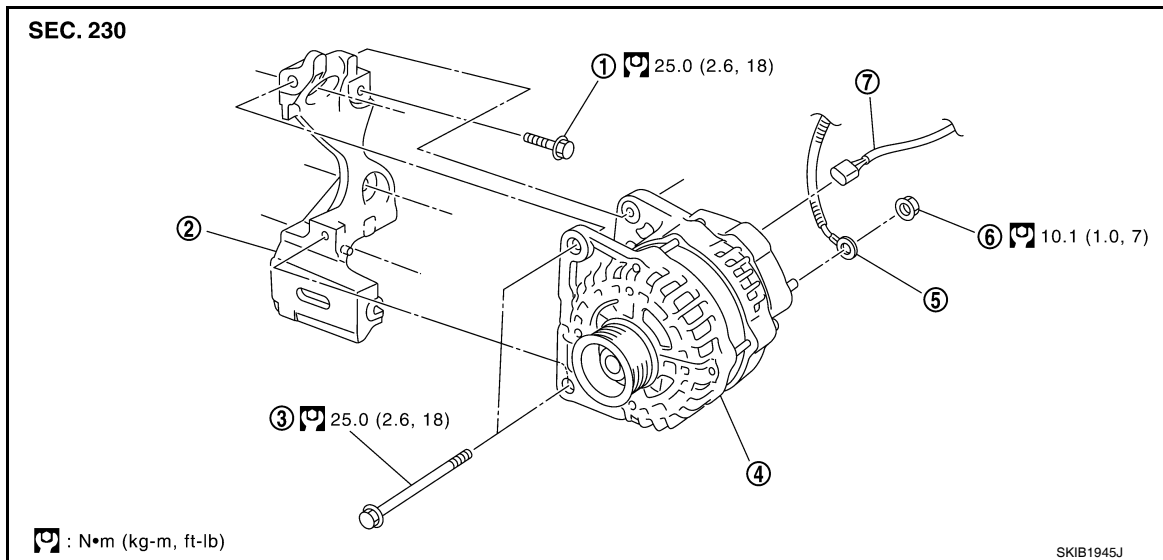

- |                           |                                   |                     |
|---------------------------|-----------------------------------|---------------------|
| 1. Generator bracket bolt | 2. Generator bracket              | 3. Generator bolt   |
| 4. Generator              | 5. Generator "B" terminal harness | 6. "B" terminal nut |
| 7. Generator connector    |                                   |                     |

### REMOVAL

1. Disconnect the battery negative terminal. Refer to [SC-7, "Removal and Installation \(MR20DE Battery\)"](#).
2. Remove RH front wheel and tire. Refer to [WT-7, "Adjustment"](#).
3. Remove splash shield RH. Refer to [EI-23, "Component"](#).
4. Remove drive belt. Refer to [EM-13, "Removal and Installation"](#).
5. Disconnect generator connector.
6. Remove "B" terminal nut.
7. Remove generator bolts.
8. Remove generator assembly from the vehicle.

### INSTALLATION

#### CAUTION:

**Generator bolts must be tightened in sequence.**

1. Install and temporarily tighten the lower generator bolt.
2. Install and temporarily tighten the upper generator bolt.
3. Tighten the upper generator bolt to specification.
4. Tighten the lower generator bolt to specification.

#### NOTE:

Slide bushing must contact engine bracket after generator is installed.  
Installation of the remaining components is in the reverse order of removal.

#### CAUTION:

**Be sure to tighten "B" terminal nut carefully.**



# CHARGING SYSTEM

< SERVICE INFORMATION >

## Removal and Installation QR25DE

INFOID:000000006152145

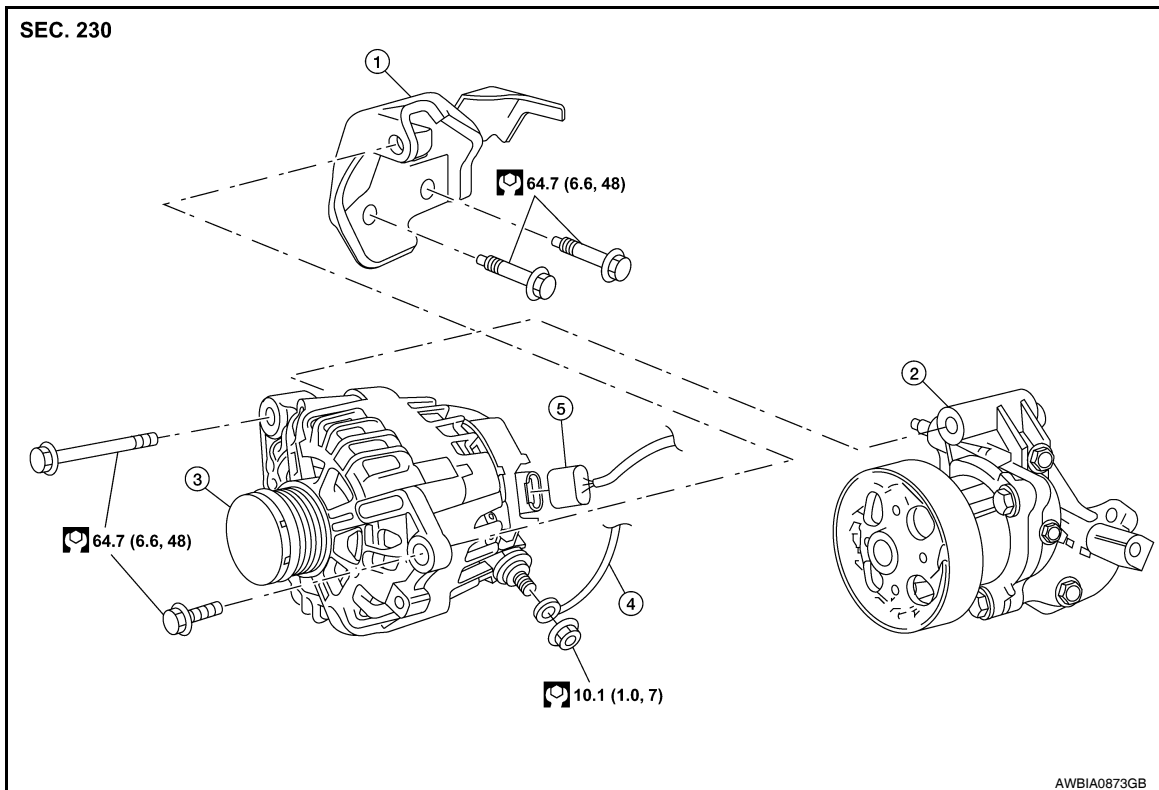

- |                                   |                        |              |
|-----------------------------------|------------------------|--------------|
| 1. Generator bracket              | 2. Water pump          | 3. Generator |
| 4. Generator "B" terminal harness | 5. Generator connector |              |

### REMOVAL

1. Disconnect the battery negative terminal. Refer to [SC-8, "Removal and Installation \(QR25DE Battery\)"](#).
2. Remove splash shield RH. Refer to [EI-23, "Component"](#).
3. Remove drive belt. Refer to [EM-13, "Removal and Installation"](#).
4. Disconnect generator connector.
5. Remove "B" terminal nut.
6. Remove harness bracket and position aside.
7. Remove generator bolts.
8. Remove generator assembly from the vehicle.

### INSTALLATION

#### **CAUTION:**

**Generator bolts must be tightened in sequence.**

1. Install and temporarily tighten the lower generator bolt.
2. Install and temporarily tighten the upper generator bolt.
3. Tighten the upper generator bolt to specification.
4. Tighten the lower generator bolt to specification.

#### **NOTE:**

Slide bushing must contact engine bracket after generator is installed.  
Installation of the remaining components is in the reverse order of removal.

#### **CAUTION:**

**Be sure to tighten "B" terminal nut carefully.**

### Generator Pulley Inspection

INFOID:000000006152146

### GENERATOR PULLEY INSPECTION

# CHARGING SYSTEM

## < SERVICE INFORMATION >

### One-Way Clutch Pulley Check

**CAUTION:**

**Be careful not to damage rotor**

**NOTE:**

Secure rotor using suitable tool and a rolled shop towel.

1. Check for locking; (Outer ring is turned clockwise when viewed from front.)
  - If it rotates in both directions, replace generator.
2. Check for dragging. (Outer ring is turned counterclockwise when viewed from front.)
  - If it locks or unusual resistance is felt, replace generator.

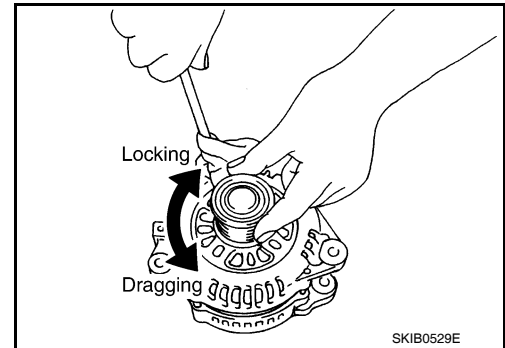

# SERVICE DATA AND SPECIFICATIONS (SDS)

< SERVICE INFORMATION >

## SERVICE DATA AND SPECIFICATIONS (SDS)

### Battery

INFOID:000000006152147

Engine	MR20DE	QR25DE
Type*	21 R	40R
Capacity (20 HR) minimum V-AH	12 V - 49 AH minimum	12V - 60 AH minimum
Cold Cranking Amps	470 @ -18°C (0°F)	550 @ -18°C (0°F)

\*: Always check with the Parts Department for the latest parts information

### Starter

INFOID:000000006152148

Engine	MR20DE		QR25DE	
Application	California	Except California	CVT	M/T
Type*	S114-944A	S114-955	M000TA0271ZC	M000T22272ZC
	HITACHI		MITSUBISHI	
	Reduction gear type			
System voltage	12 V			
No-load	Terminal voltage	11 V		
	Current	Less than 110 A		Less than 90A
	Revolution	More than 3,750 rpm	More than 3,000 rpm	More than 2,400 rpm

\*: Always check with the Parts Department for the latest parts information

### Generator

INFOID:000000006152149

Engine	MR20DE	QR25DE
Type*	A002TG1581AC	TG11S102
	MITSUBISHI	VALEO
Nominal rating	12 V - 100 A	12 V - 110 A
Ground polarity	Negative	
Minimum revolution under no-load	Less than 1,000 rpm	Less than 1,200 rpm
Hot output current (when 13.5 V is applied)	More than 16 A/1,300 rpm More than 82 A/2,500 rpm More than 97 A/5,000 rpm	More than 46 A/1,500 rpm More than 68 A/1,800 rpm More than 91 A/2,500 rpm More than 105 A/5,000 rpm
Regulated output voltage	14.1 - 14.7 V	11.4 - 15.6 V

\*: Always check with the Parts Department for the latest parts information