

DI

SECTION

DRIVER INFORMATION SYSTEM

CONTENTS

<p>SERVICE INFORMATION 3</p> <p>PRECAUTION 3</p> <p style="padding-left: 20px;">Precaution for Supplemental Restraint System (SRS) "AIR BAG" and "SEAT BELT PRE-TENSIONER"3</p> <p style="padding-left: 20px;">Precaution Necessary for Steering Wheel Rotation After Battery Disconnect3</p> <p style="padding-left: 20px;">Precaution for Work4</p> <p>PREPARATION 5</p> <p style="padding-left: 20px;">Special Service Tool5</p> <p style="padding-left: 20px;">Commercial Service Tool5</p> <p>COMBINATION METERS 6</p> <p style="padding-left: 20px;">Component Parts and Harness Connector Location6</p> <p style="padding-left: 20px;">System Description6</p> <p style="padding-left: 20px;">Arrangement of Combination Meter9</p> <p style="padding-left: 20px;">Schematic10</p> <p style="padding-left: 20px;">Wiring Diagram - METER -11</p> <p style="padding-left: 20px;">Combination Meter Harness Connector Terminal Layout13</p> <p style="padding-left: 20px;">Terminal and Reference Value for Combination Meter13</p> <p style="padding-left: 20px;">Self-Diagnosis Mode of Combination Meter14</p> <p style="padding-left: 20px;">CONSULT Function (METER/M&A)15</p> <p style="padding-left: 20px;">Trouble Diagnosis17</p> <p style="padding-left: 20px;">Symptom Chart17</p> <p style="padding-left: 20px;">Power Supply and Ground Circuit Inspection18</p> <p style="padding-left: 20px;">Vehicle Speed Signal Inspection19</p> <p style="padding-left: 20px;">Engine Speed Signal Inspection19</p> <p style="padding-left: 20px;">Water Temperature Signal Inspection19</p> <p style="padding-left: 20px;">Fuel Level Sensor Signal Inspection19</p> <p style="padding-left: 20px;">Fuel Gauge Fluctuates, Indicates Wrong Value, or Varies21</p> <p style="padding-left: 20px;">Fuel Gauge Does Not Move to Full-position21</p> <p style="padding-left: 20px;">DTC [U1000] CAN Communication Circuit22</p> <p style="padding-left: 20px;">Electrical Component Inspection22</p> <p style="padding-left: 20px;">Removal and Installation22</p>	<p>DOUBLE METERS24</p> <p style="padding-left: 20px;">System Description24</p> <p style="padding-left: 20px;">Wiring Diagram - 2METER -25</p> <p style="padding-left: 20px;">Terminal and Reference Value for Double Meter27</p> <p style="padding-left: 20px;">Terminal and Reference Value for Combination Meter27</p> <p style="padding-left: 20px;">CONSULT Function (METER/M&A)28</p> <p style="padding-left: 20px;">Trouble Diagnosis30</p> <p style="padding-left: 20px;">Symptom Chart30</p> <p style="padding-left: 20px;">Power Supply and Ground Circuit Inspection30</p> <p style="padding-left: 20px;">Oil Pressure Sensor Inspection31</p> <p style="padding-left: 20px;">Removal and Installation33</p> <p>WARNING LAMPS35</p> <p style="padding-left: 20px;">Schematic35</p> <p style="padding-left: 20px;">Wiring Diagram - WARN -36</p> <p style="padding-left: 20px;">Oil Pressure Warning Lamp Stays Off (Ignition Switch ON)43</p> <p style="padding-left: 20px;">Oil Pressure Warning Lamp Does Not Turn Off (Oil Pressure Is Normal)45</p> <p style="padding-left: 20px;">Component Inspection46</p> <p>CVT INDICATOR47</p> <p style="padding-left: 20px;">System Description47</p> <p style="padding-left: 20px;">Schematic48</p> <p style="padding-left: 20px;">Wiring Diagram - CVTIND -49</p> <p style="padding-left: 20px;">CVT Indicator Does Not Illuminate51</p> <p>WARNING CHIME53</p> <p style="padding-left: 20px;">Component Parts and Harness Connector Location53</p> <p style="padding-left: 20px;">System Description54</p> <p style="padding-left: 20px;">Wiring Diagram - CHIME -57</p> <p style="padding-left: 20px;">Terminal and Reference Value for BCM59</p> <p style="padding-left: 20px;">CONSULT Function (BCM)62</p> <p style="padding-left: 20px;">Trouble Diagnosis64</p> <p style="padding-left: 20px;">Combination Meter Buzzer Circuit Inspection64</p> <p style="padding-left: 20px;">Front Door Switch LH Signal Inspection65</p> <p style="padding-left: 20px;">Key Switch Signal Inspection (Without Intelligent Key)66</p>
---	---

Key Switch and Ignition Knob Switch Signal Inspection (With Intelligent Key, When Mechanical Key Is Used)	67
Lighting Switch Signal Inspection	69
Seat Belt Buckle Switch LH Signal Inspection	69
Parking Brake Switch Signal Inspection	70
Electrical Component Inspection	71

BOARD COMPUTER	73
System Description	73
CAN Communication System Description	73
Wiring Diagram - B/COMP -	74
Trouble Diagnosis	76
Ambient Air Temperature Signal Inspection	76
Electrical Component Inspection	77

PRECAUTION

< SERVICE INFORMATION >

SERVICE INFORMATION

PRECAUTION

Precaution for Supplemental Restraint System (SRS) "AIR BAG" and "SEAT BELT PRE-TENSIONER"

INFOID:000000007403061

The Supplemental Restraint System such as "AIR BAG" and "SEAT BELT PRE-TENSIONER", used along with a front seat belt, helps to reduce the risk or severity of injury to the driver and front passenger for certain types of collision. This system includes seat belt switch inputs and dual stage front air bag modules. The SRS system uses the seat belt switches to determine the front air bag deployment, and may only deploy one front air bag, depending on the severity of a collision and whether the front occupants are belted or unbelted. Information necessary to service the system safely is included in the SRS and SB section of this Service Manual.

WARNING:

- To avoid rendering the SRS inoperative, which could increase the risk of personal injury or death in the event of a collision which would result in air bag inflation, all maintenance must be performed by an authorized NISSAN/INFINITI dealer.
- Improper maintenance, including incorrect removal and installation of the SRS can lead to personal injury caused by unintentional activation of the system. For removal of Spiral Cable and Air Bag Module, see the SRS section.
- Do not use electrical test equipment on any circuit related to the SRS unless instructed to in this Service Manual. SRS wiring harnesses can be identified by yellow and/or orange harnesses or harness connectors.

PRECAUTIONS WHEN USING POWER TOOLS (AIR OR ELECTRIC) AND HAMMERS

WARNING:

- When working near the Airbag Diagnosis Sensor Unit or other Airbag System sensors with the Ignition ON or engine running, DO NOT use air or electric power tools or strike near the sensor(s) with a hammer. Heavy vibration could activate the sensor(s) and deploy the air bag(s), possibly causing serious injury.
- When using air or electric power tools or hammers, always switch the Ignition OFF, disconnect the battery, and wait at least 3 minutes before performing any service.

Precaution Necessary for Steering Wheel Rotation After Battery Disconnect

INFOID:000000007403062

NOTE:

- This Procedure is applied only to models with Intelligent Key system and NATS (NISSAN ANTI-THEFT SYSTEM).
- Remove and install all control units after disconnecting both battery cables with the ignition knob in the "LOCK" position.
- Always use CONSULT to perform self-diagnosis as a part of each function inspection after finishing work. If DTC is detected, perform trouble diagnosis according to self-diagnostic results.

For models equipped with the Intelligent Key system and NATS, an electrically controlled steering lock mechanism is adopted on the key cylinder.

For this reason, if the battery is disconnected or if the battery is discharged, the steering wheel will lock and steering wheel rotation will become impossible.

If steering wheel rotation is required when battery power is interrupted, follow the procedure below before starting the repair operation.

OPERATION PROCEDURE

1. Connect both battery cables.

NOTE:

Supply power using jumper cables if battery is discharged.

2. Use the Intelligent Key or mechanical key to turn the ignition switch to the "ACC" position. At this time, the steering lock will be released.
3. Disconnect both battery cables. The steering lock will remain released and the steering wheel can be rotated.
4. Perform the necessary repair operation.

A
B
C
D
E
F
G
H
I
J
DI
L
M
N
O
P

PRECAUTION

< SERVICE INFORMATION >

5. When the repair work is completed, return the ignition switch to the "LOCK" position before connecting the battery cables. (At this time, the steering lock mechanism will engage.)
6. Perform a self-diagnosis check of all control units using CONSULT.

Precaution for Work

INFOID:000000007403063

- When removing or disassembling each component, be careful not to damage or deform it. If a component may be subject to interference, be sure to protect it with a shop cloth.
- When removing (disengaging) components with a screwdriver or similar tool, be sure to wrap the component with a shop cloth or vinyl tape to protect it.
- Protect the removed parts with a shop cloth and prevent them from being dropped.
- Replace a deformed or damaged clip.
- If a part is specified as a non-reusable part, always replace it with a new one.
- Be sure to tighten bolts and nuts securely to the specified torque.
- After installation is complete, be sure to check that each part works properly.
- Follow the steps below to clean components:
 - Water soluble dirt:
 - Dip a soft cloth into lukewarm water, wring the water out of the cloth and wipe the dirty area.
 - Then rub with a soft, dry cloth.
 - Oily dirt:
 - Dip a soft cloth into lukewarm water with mild detergent (concentration: within 2 to 3%) and wipe the dirty area.
 - Then dip a cloth into fresh water, wring the water out of the cloth and wipe the detergent off.
 - Then rub with a soft, dry cloth.
 - Do not use organic solvent such as thinner, benzene, alcohol or gasoline.
 - For genuine leather seats, use a genuine leather seat cleaner.

PREPARATION

< SERVICE INFORMATION >

PREPARATION

Special Service Tool

INFOID:000000007403064

The actual shapes of Kent-Moore tools may differ from those of special service tools illustrated here.

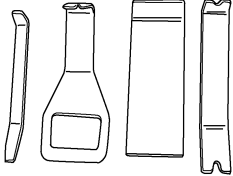
Tool number (Kent-Moore No.) Tool name	Description
— (J-46534) Trim Tool Set  AWJIA0483ZZ	Removing trim components

Commercial Service Tool

INFOID:000000007403065

Tool name	Description
Power Tool  PIIB1407E	Loosening nuts, screws and bolts

A
B
C
D
E
F
G
H
I
J
L
M
N
O
P

DI

COMBINATION METERS

< SERVICE INFORMATION >

COMBINATION METERS

Component Parts and Harness Connector Location

INFOID:000000007403066

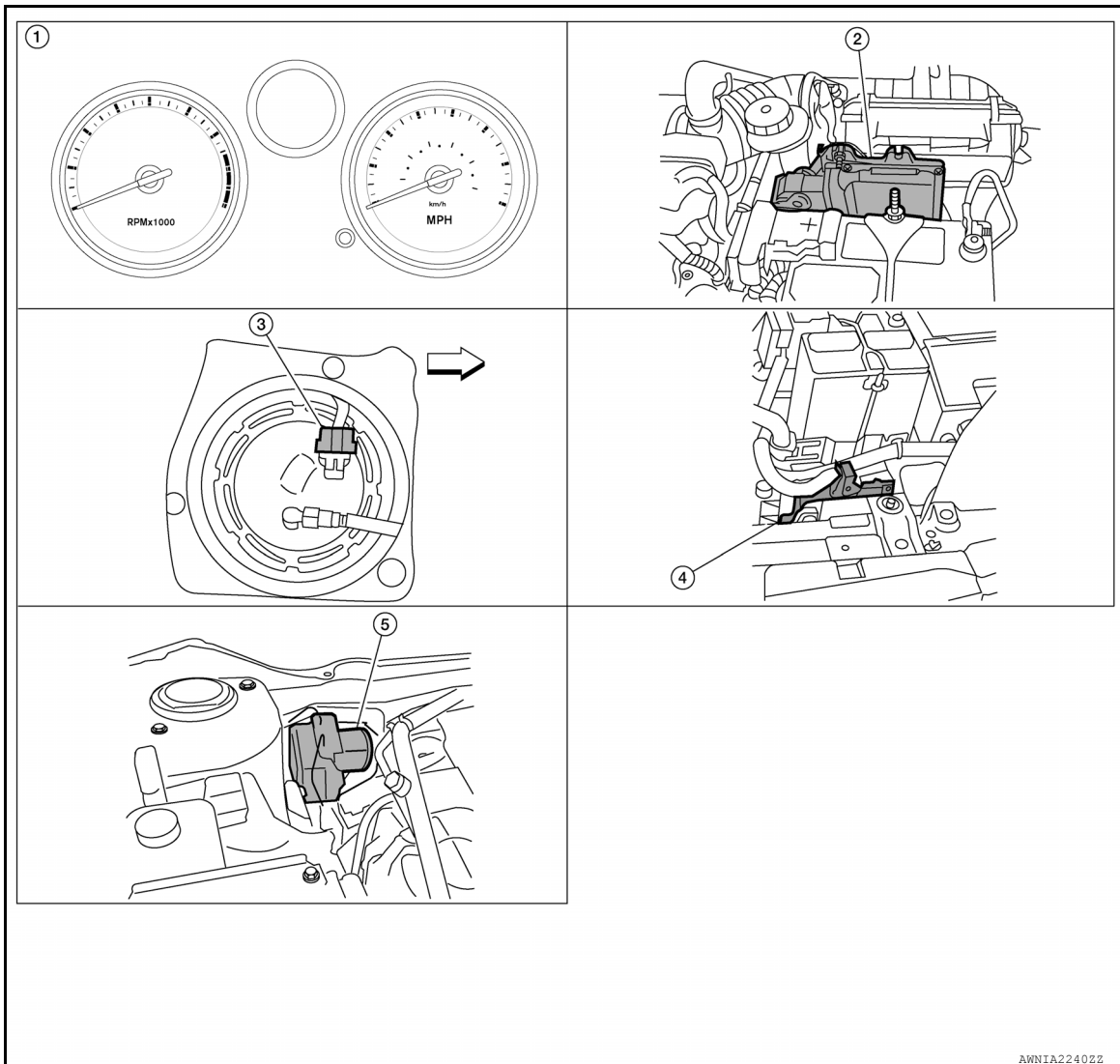

- | | | |
|--------------------------|--|--|
| 1. Combination meter M24 | 2. ECM E16 | 3. Fuel level sensor unit and fuel pump (fuel level sensor) B48 (view with rear seat and inspection hole cover removed) (←: Front) |
| 4. TCM F23 | 5. ABS actuator and electric unit (control unit) E33 | |

System Description

INFOID:000000007403067

UNIFIED METER CONTROL UNIT

- Speedometer, odo/trip meter, tachometer, water temperature gauge and fuel gauge are controlled by the unified meter control unit, which is built into the combination meter.
- Warning and indicator lamps are controlled by signals drawn from the CAN communication system, BCM (body control module), and components connected directly to the combination meter.
- Odo/trip meter and CVT indicator segments can be checked in self-diagnosis mode.
- Meters/gauges can be checked in self-diagnosis mode.

POWER SUPPLY AND GROUND CIRCUIT

COMBINATION METERS

< SERVICE INFORMATION >

Power is supplied at all times

- through 10A fuse [No. 19, located in the fuse block (J/B)]
- to combination meter terminal 1.

With the ignition switch in the ON or START position, power is supplied

- through 10A fuse [No. 14, located in the fuse block (J/B)]
- to combination meter terminal 2.

With the ignition switch in the ACC or ON position, power is supplied

- through 10A fuse [No. 6, located in the fuse block (J/B)]
- to combination meter terminal 23.

Ground is supplied

- to combination meter terminals 3, 21 and 22
- through grounds M57 and M61.

SPEEDOMETER

The ABS actuator and electric unit (control unit) provides a vehicle speed signal to the combination meter via CAN communication lines.

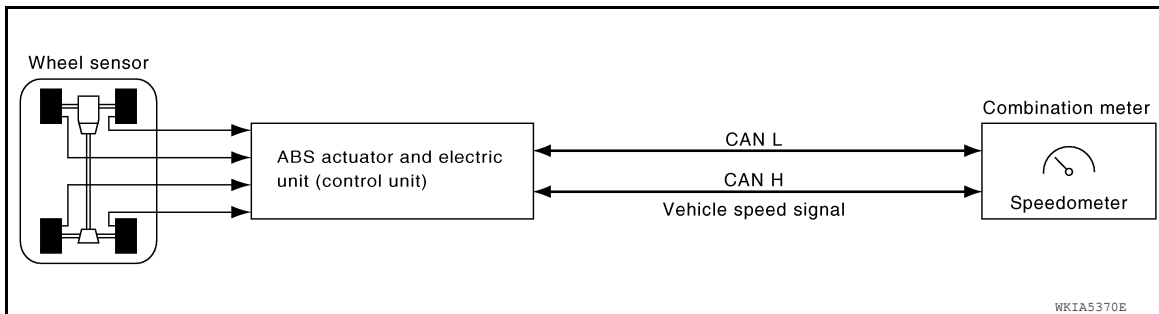

TACHOMETER

The tachometer indicates engine speed in revolutions per minute (rpm). The ECM provides an engine speed signal to combination meter via CAN communication lines.

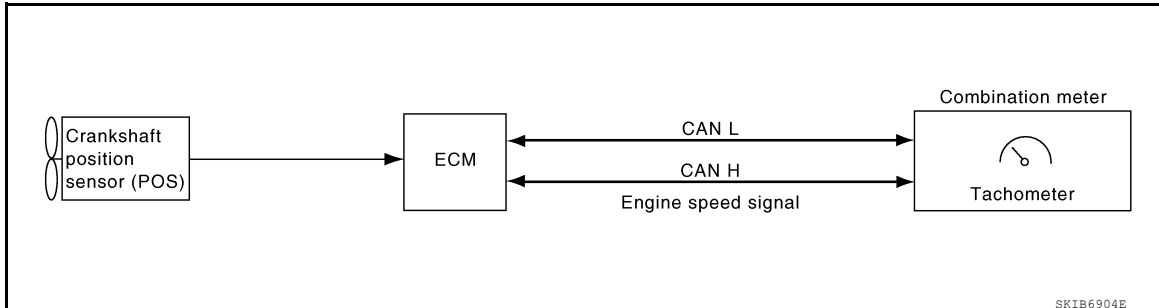

FUEL GAUGE

The fuel gauge indicates the approximate fuel level in the fuel tank.

The fuel gauge is regulated by the unified meter control unit and a variable resistor signal supplied

- to combination meter terminal 4
- through fuel level sensor unit and fuel pump terminal 5
- through fuel level sensor unit and fuel pump terminal 2
- from combination meter terminal 8.

WATER TEMPERATURE GAUGE

The water temperature gauge indicates the engine coolant temperature.

COMBINATION METERS

< SERVICE INFORMATION >

The ECM provides an engine coolant temperature signal to the combination meter via CAN communication lines.

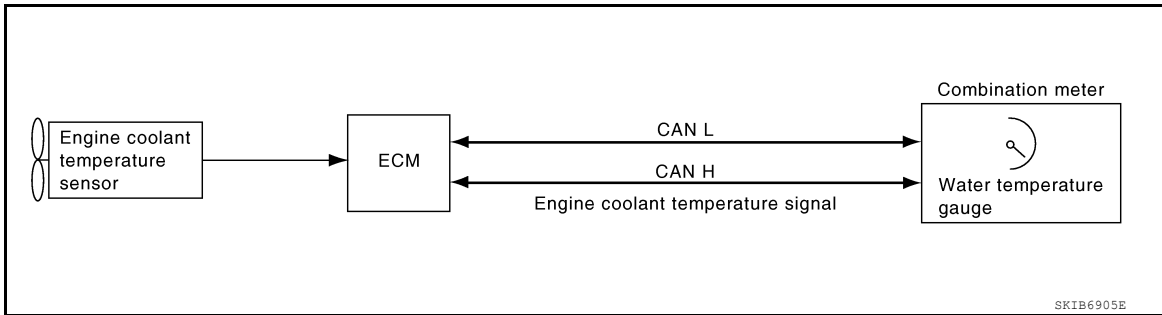

ODO/TRIP METER

The vehicle speed signal and the memory signals from the meter memory circuit are processed by the combination meter and the mileage is displayed.

Loose Fuel Cap Indicator

The LOOSE FUEL CAP indicator will display in the odometer when the fuel-filler cap is not tightened correctly. The indicator will turn off as soon as the ECM detects the fuel-filler cap is properly tightened. The ECM provides a loose fuel cap signal to the combination meter via CAN communication lines.

How to Change the Display

Refer to Owner's Manual for odo/trip meter operating instructions.

CAN COMMUNICATION SYSTEM DESCRIPTION

Refer to [LAN-7, "System Description"](#).

COMBINATION METERS

< SERVICE INFORMATION >

Arrangement of Combination Meter

INFOID:000000007403068

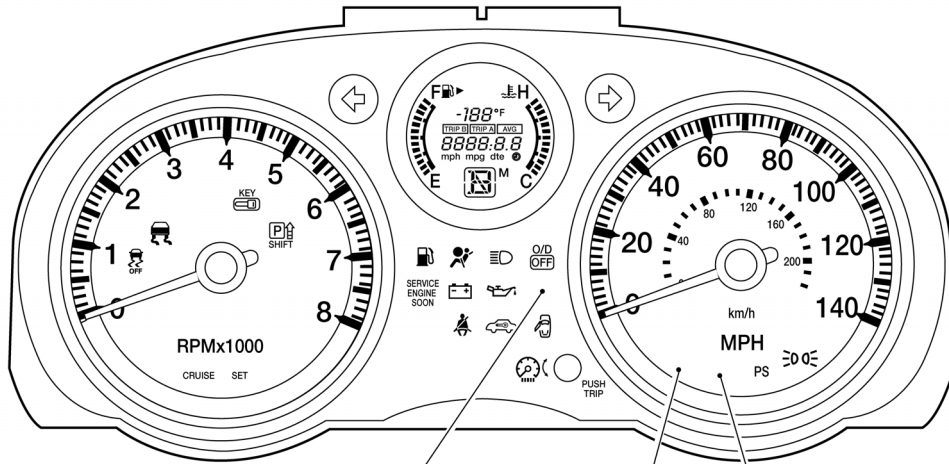

BRAKE : U
 (!) : N
 ABS : U
 (ABS) : N

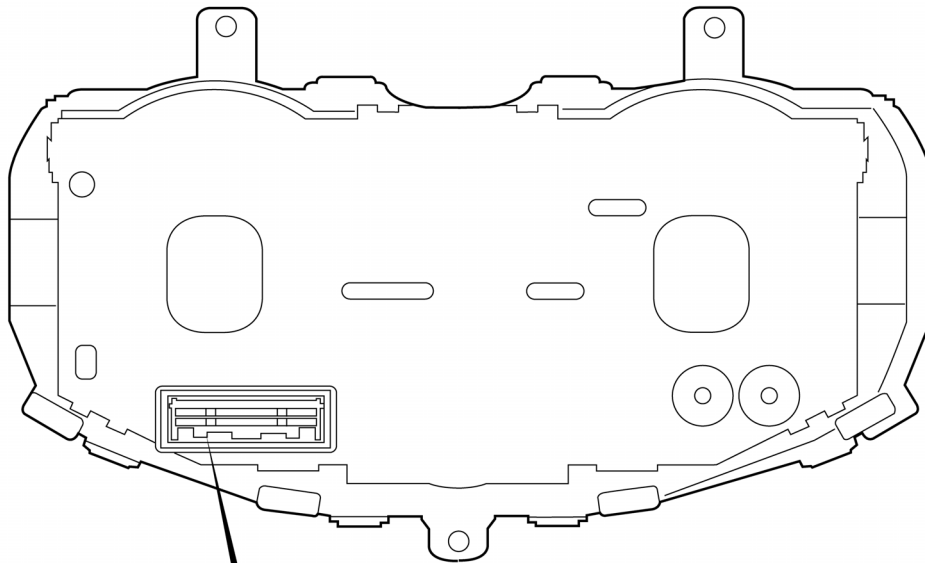

1	2	3	4	5	6	7	8	9	10	11	12	13	14	15	16	17	18	19	20	(M24)
21	22	23	24	25	26	27	28	29	30	31	32	33	34	35	36	37	38	39	40	

(N) : Canada

(U) : USA

AWNIA24242Z

A
B
C
D
E
F
G
H
I
J
K
L
M
N
O
P

DI

COMBINATION METERS

< SERVICE INFORMATION >

Schematic

INFOID:000000007403069

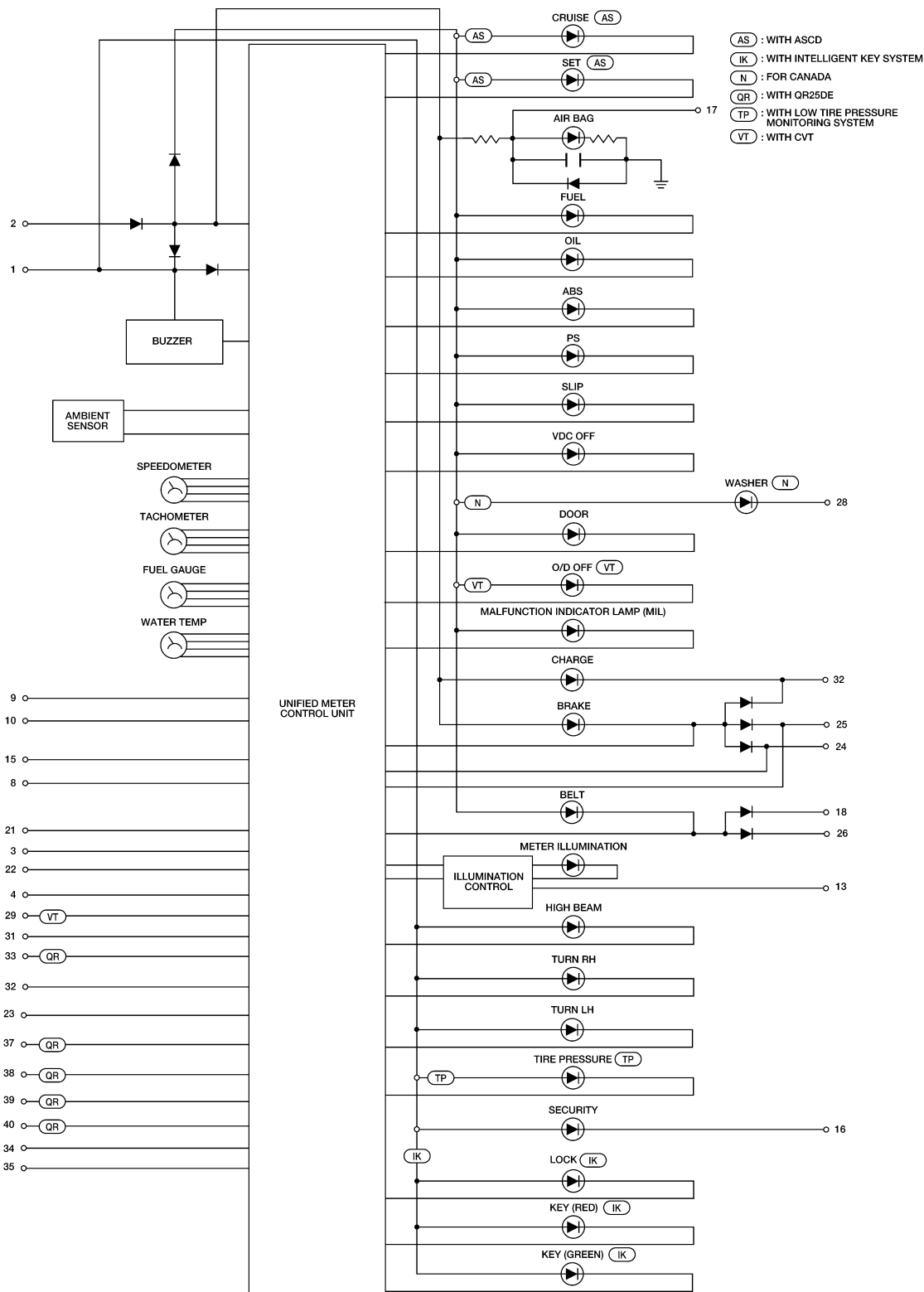

AANWA0458GB

COMBINATION METERS

< SERVICE INFORMATION >

Wiring Diagram - METER -

INFOID:000000007403070

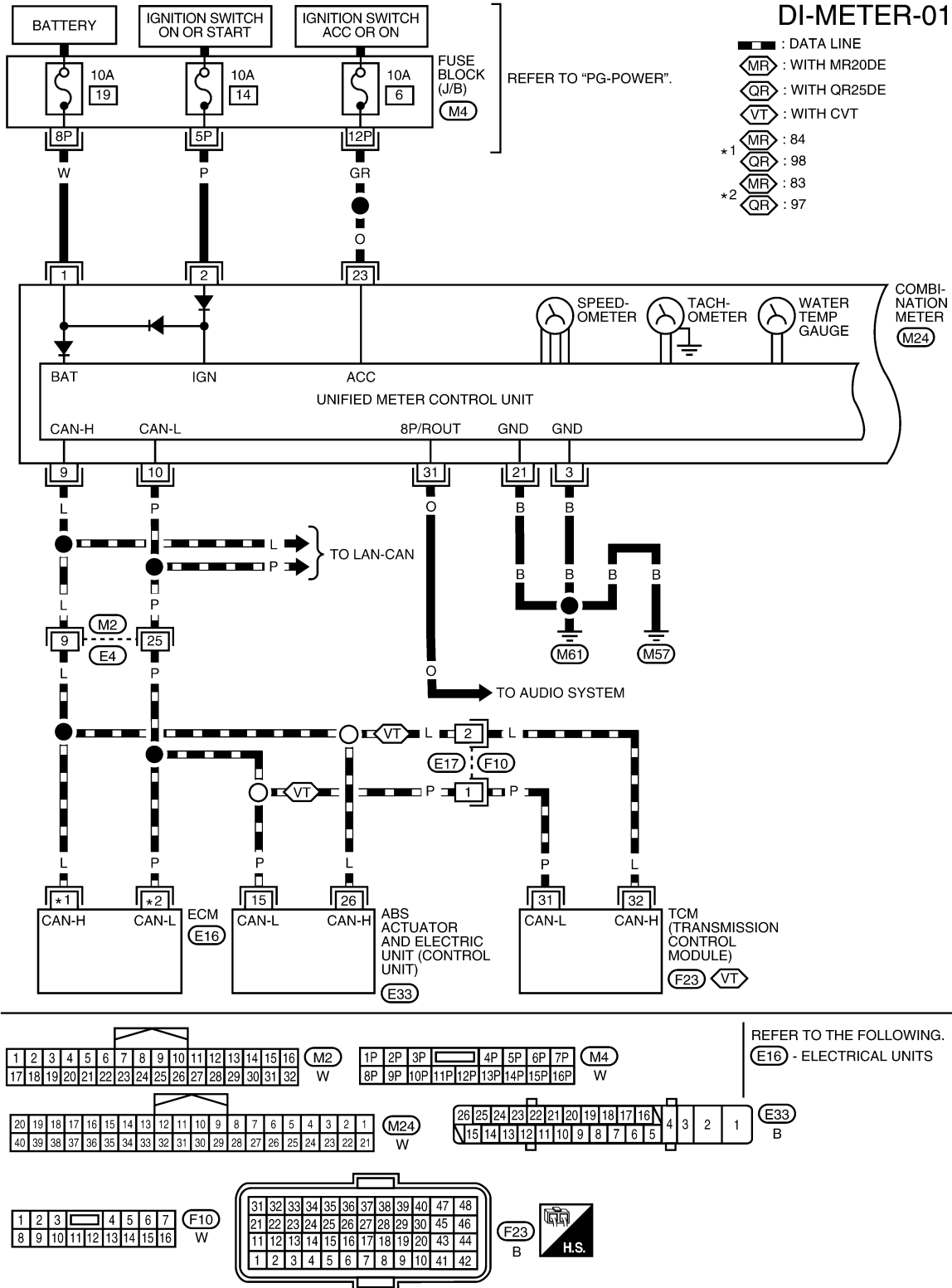

A
B
C
D
E
F
G
H
I
J
K
L
M
N
O
P



COMBINATION METERS

< SERVICE INFORMATION >

DI-METER-02

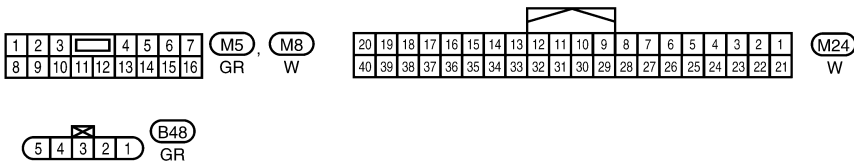
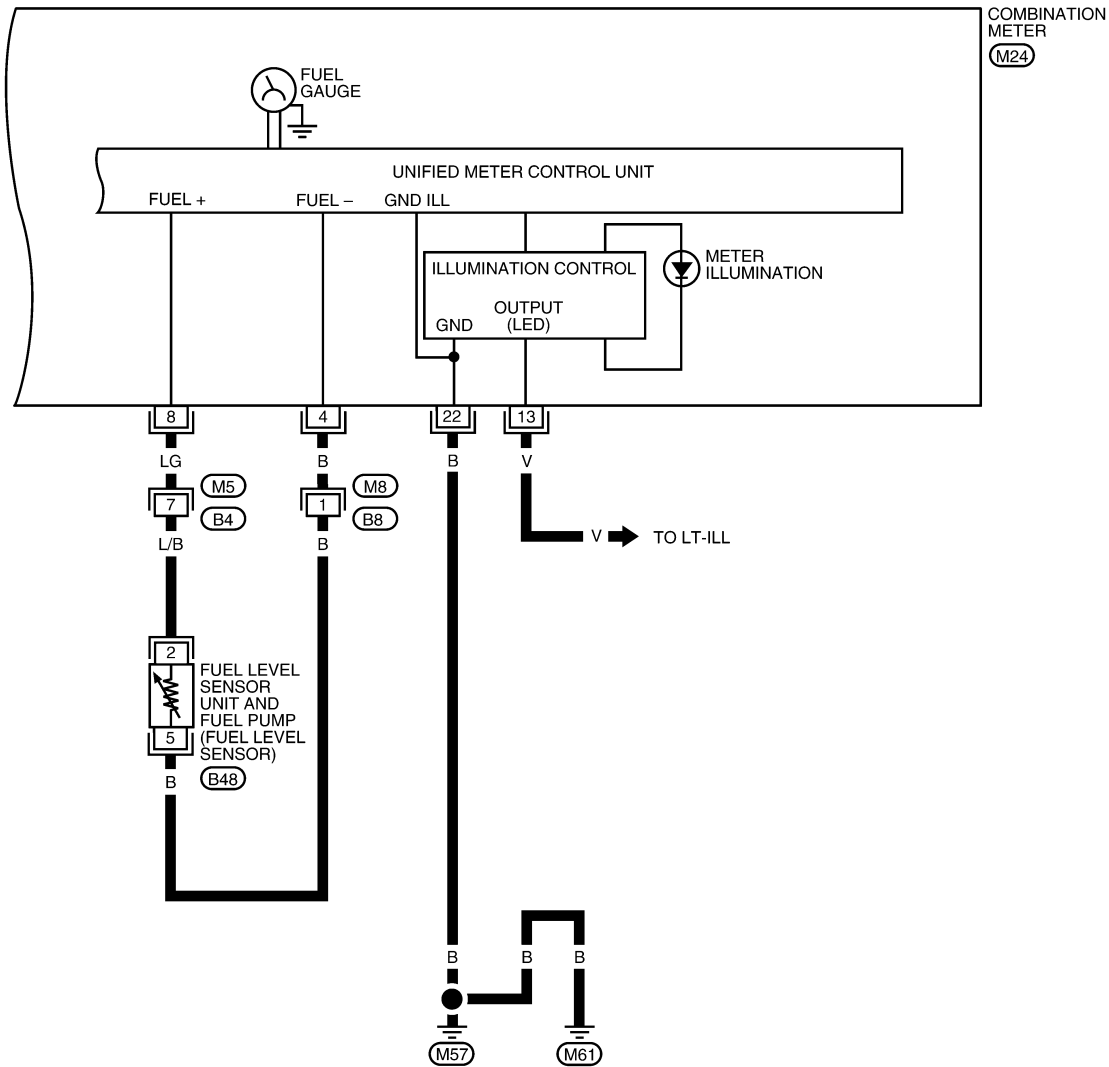

AANWA0167GB

COMBINATION METERS

< SERVICE INFORMATION >

Combination Meter Harness Connector Terminal Layout

INFOID:000000007403071

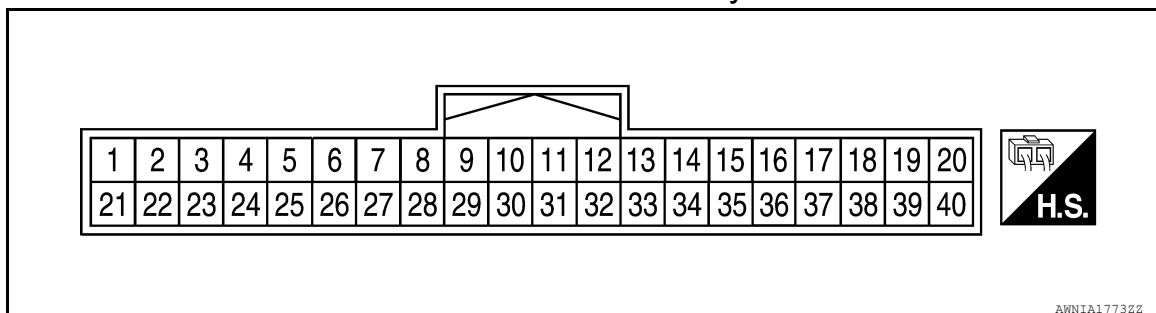

Terminal and Reference Value for Combination Meter

INFOID:000000007403072

Terminal No.	Wire color	Item	Condition		Reference value (V) (Approx.)
			Ignition switch	Operation or condition	
1	W	Battery power supply	OFF	—	Battery voltage
2	P	Ignition switch ON or START	ON	—	Battery voltage
3	B	Ground (power)	—	—	0
4	B	Fuel level sensor ground (-)	ON	—	0
8	LG	Fuel level sensor signal (+)	—	—	Refer to DI-22, "Electrical Component Inspection" .
9	L	CAN-H	—	—	—
10	P	CAN-L	—	—	—
13	V	Illumination control switch (LED)	—	—	Refer to LT-99, "System Description" .
16	SB	Immobilizer/security indicator input	OFF	Security indicator ON	0
				Security indicator OFF	Battery voltage
18	G	Seat belt buckle switch RH	ON	Unfastened (ON)	0
				Fastened (OFF)	Battery voltage
21	B	Ground (illumination)	—	—	0
22					
23	O	Ignition switch ACC or ON	ON	—	Battery voltage
24	GR	Parking Brake switch	ON	Parking brake applied	0
				Parking brake released	Battery voltage
25	V	Brake fluid level switch	ON	Brake fluid level low	0
				Brake fluid level normal	Battery voltage
26	O	Seat belt buckle switch LH	ON	Unfastened (ON)	0
				Fastened (OFF)	Battery voltage
28	R	Washer fluid level switch (Canada models)	ON	Washer fluid level low	0
				Washer fluid level normal	Battery voltage
29	W	O/D OFF switch	ON	O/D OFF switch pressed	0
				O/D OFF switch released	Battery voltage

COMBINATION METERS

< SERVICE INFORMATION >

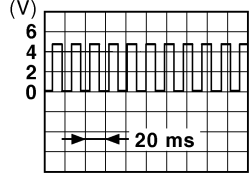
Ter- mi- nal No.	Wire color	Item	Condition		Reference value (V) (Approx.)
			Ignition switch	Operation or condition	
31	O	Vehicle speed signal output (8-pulse)	ON	Speedometer operated [When vehicle speed is approx. 40 km/h (25 MPH)]	NOTE: Maximum voltage may be 12 V due to specifications (connected units).  <small>PKIC0643E</small>
32	BR	Generator	ON	Generator voltage low	0
				Generator voltage normal	Battery voltage
33	V	Illumination output to double meter	—	—	Refer to LT-99, "System Description" .
34	LG	Ambient sensor power	ON	—	5
35	B	Ambient sensor ground	ON	—	0 - 5 (Based on ambient temperature)
37*	LG	Manual mode signal	ON	Manual mode switch ON	0
				Manual mode switch OFF	Battery voltage
38*	SB	Not manual mode signal	ON	Manual mode switch ON	0
				Manual mode switch OFF	Battery voltage
39*	W	CVT steering shift up signal	ON	<ul style="list-style-type: none"> Manual mode switch ON Steering shift up operation 	0
				Other than above	Battery voltage
40*	Y	CVT steering shift down sig- nal	ON	<ul style="list-style-type: none"> Manual mode switch ON Steering shift down operation 	0
				Other than above	Battery voltage

*: With QR25DE

Self-Diagnosis Mode of Combination Meter

INFOID:000000007403073

SELF-DIAGNOSIS MODE FUNCTION

- Self-diagnosis can check for continuity between the meter control circuit and the speedometer and tachometer.
- Self-diagnosis can check for odo/trip meter and CVT indicator segments.

OPERATION PROCEDURE

1. Turn the ignition switch ON, and switch the odo/trip meter to "trip A" or "trip B".

NOTE:

If the diagnosis function is activated with "trip A" displayed, the mileage on "trip A" will indicate "0000.0", but the actual trip mileage will be retained. (The same applies for "trip B".)

2. Turn ignition switch OFF.

COMBINATION METERS

< SERVICE INFORMATION >

3. While pushing the odo/trip meter switch (1), turn the ignition switch ON.
4. Confirm that the trip meter displays "0000.0".
5. Push the odo/trip meter switch at least 3 times. (Within 7 seconds after the ignition switch is turned ON.)

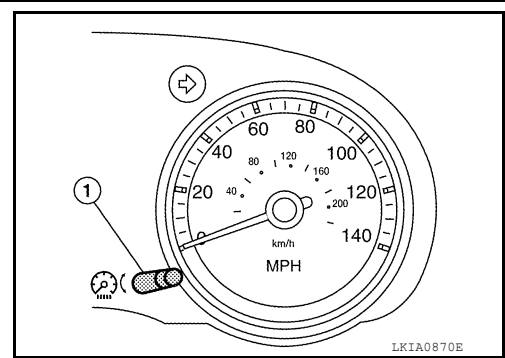

6. All segments on the odo/trip meter illuminate. At this time, the unified meter control unit is turned to self-diagnosis mode.

NOTE:

- Check combination meter power supply and ground circuit when self-diagnosis mode of combination meter does not start. Replace combination meter if normal. Refer to [IP-12. "Removal and Installation"](#).
- If any of the segments is not displayed, replace combination meter. Refer to [IP-12. "Removal and Installation"](#).

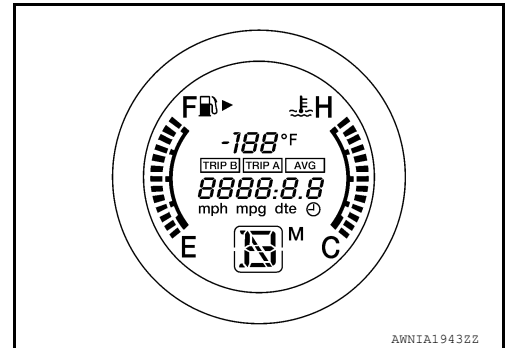

7. Each meter activates while pressing odo/trip meter switch.

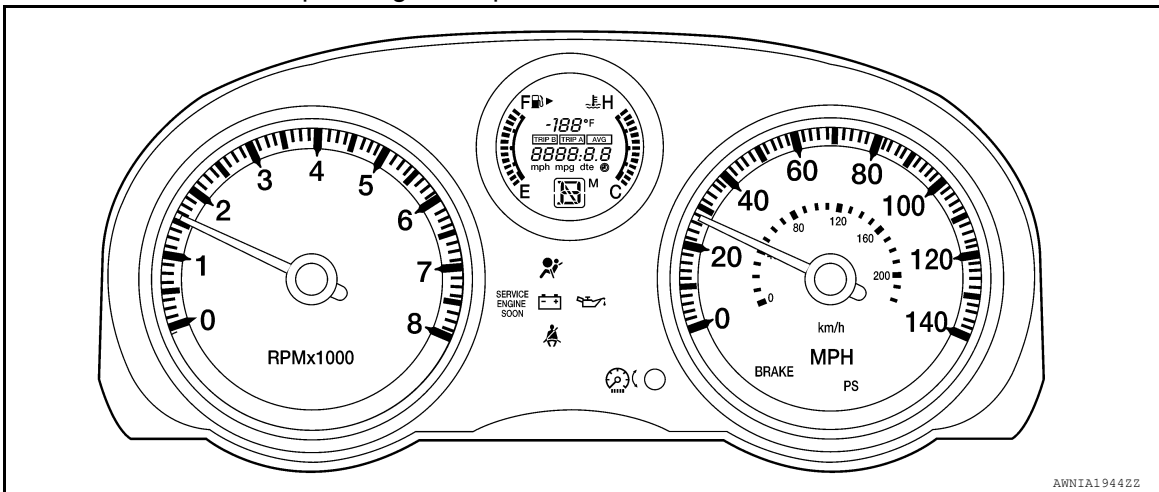

NOTE:

If the speedometer or tachometer are not activated, replace combination meter. Refer to [IP-12. "Removal and Installation"](#).

CONSULT Function (METER/M&A)

INFOID:000000007403074

CONSULT can display each diagnostic item using the diagnostic test modes shown following.

METER diagnosis mode	Description
SELF DIAGNOSTIC RESULT	Displays combination meter self-diagnosis results.
DATA MONITOR	Displays combination meter input/output data in real time.
CAN DIAG SUPPORT MNTR	The result of transmit/receive diagnosis of CAN communication can be read.

SELF-DIAGNOSTIC RESULTS

Display Item List

COMBINATION METERS

< SERVICE INFORMATION >

CONSULT display	Malfunction	Reference page
CAN COMM CIRC [U1000]	Malfunction is detected in CAN communication lines. CAUTION: Even when there is no malfunction on CAN communication system, malfunction may be misinterpreted when battery has low voltage (when maintaining 7 - 8 V for about 2 seconds) or 10A fuse [No. 14, located in the fuse block (J/B)] is removed.	DI-22
VEHICLE SPEED CIRC [B2205]	Malfunction is detected when an erroneous speed signal is input. CAUTION: Even when there is no malfunction on speed signal system, malfunctions may be misinterpreted when battery has low voltage (when maintaining 7 - 8 V for about 2 seconds).	DI-19

NOTE:

“TIME” indicates the following.

- 0: Indicates that a malfunction is detected at present.
- 1-63: Indicates that a malfunction was detected in the past. (Displays number of ignition switch OFF → ON cycles after malfunction is detected. Self-diagnostic result is erased when “63” is exceeded.)

DATA MONITOR

Display Item List

Display item [Unit]	MAIN SIGNALS	SELECTION FROM MENU	Contents
SPEED METER [km/h]	X	X	The value of vehicle speed signal, which is input from ABS actuator and electric unit (control unit).
SPEED OUTPUT [km/h]	X	X	The value of vehicle speed signal, which is transmitted to each unit with CAN communication.
TACHO METER [rpm]	X	X	The value of engine speed signal, which is input from ECM.
W TEMP METER [°C]	X	X	The value of engine coolant temperature signal, which is input from ECM.
FUEL METER [lit.]	X	X	The value, which processes a resistance signal from fuel gauge.
FUEL W/L [ON/OFF]	X	X	Indicates [ON/OFF] condition of low-fuel warning lamp.
C-ENG W/L [ON/OFF]		X	Indicates [ON/OFF] condition of malfunction indicator lamp (MIL).
AIR PRES W/L		X	Indicates [ON/OFF] condition of low tire pressure warning lamp.
SEAT BELT W/L		X	Indicates [ON/OFF] condition of seat belt warning lamp.
BUZZER [ON/OFF]	X	X	Indicates [ON/OFF] condition of buzzer.
DOOR W/L [ON/OFF]		X	Indicates [ON/OFF] condition of door warning lamp.
HI-BEAM IND [ON/OFF]		X	Indicates [ON/OFF] condition of high beam indicator lamp.
TURN IND [ON/OFF]		X	Indicates [ON/OFF] condition of turn indicator.
OIL W/L [ON/OFF]		X	Indicates [ON/OFF] condition of oil pressure warning lamp.
LIGHT IND [ON/OFF]		X	Indicates [ON/OFF] condition of the light indicator lamp.
VDC/TCS IND [ON/OFF]		X	Indicates [ON/OFF] condition of VDC OFF indicator lamp.
ABS W/L [ON/OFF]		X	Indicates [ON/OFF] condition of ABS warning lamp.
SLIP IND [ON/OFF]		X	Indicates [ON/OFF] condition of SLIP indicator lamp.
BRAKE W/L [ON/OFF]		X	Indicates [ON/OFF] condition of brake warning lamp.*
KEY G/Y W/L [ON/OFF]		X	Indicates [ON/OFF] condition of KEY warning lamp (green).
KEY R W/L [ON/OFF]		X	Indicates [ON/OFF] condition of KEY warning lamp (red).
KEY KNOB W/L [ON/OFF]		X	Indicates [ON/OFF] condition of LOCK warning lamp.
O/D OFF SW [ON/OFF]		X	Indicates [ON/OFF] condition of O/D OFF switch.
P RANGE IND [ON/OFF]	X	X	Indicates [ON/OFF] condition of CVT shift P range indicator.

COMBINATION METERS

< SERVICE INFORMATION >

Display item [Unit]	MAIN SIGNALS	SELECTION FROM MENU	Contents
R RANGE IND [ON/OFF]	X	X	Indicates [ON/OFF] condition of CVT shift R range indicator.
N RANGE IND [ON/OFF]	X	X	Indicates [ON/OFF] condition of CVT shift N range indicator.
D RANGE IND [ON/OFF]	X	X	Indicates [ON/OFF] condition of CVT shift D range indicator.
L RANGE IND [ON/OFF]	X	X	Indicates [ON/OFF] condition of CVT shift L range indicator.
M RANGE SW [ON/OFF]	X	X	Indicates [ON/OFF] condition of manual mode range switch.
NM RANGE SW [ON/OFF]	X	X	Indicates [ON/OFF] condition of except manual mode range switch.
AT-M IND [ON/OFF]	X	X	Indicates [ON/OFF] condition of manual mode indicator.
AT-M GEAR [1 - 8]	X	X	Indicates [1 - 8] condition of manual mode gear position.
SPORT IND [ON/OFF]		X	Indicates [ON/OFF] condition of O/D OFF indicator.
ST SFT UP SW [ON/OFF]		X	Indicates [ON/OFF] condition of steering shift up switch.
ST SFT DWN SW [ON/OFF]		X	Indicates [ON/OFF] condition of steering shift down switch.
CRUISE IND [ON/OFF]		X	Indicates [ON/OFF] condition of CRUISE indicator.
SET IND [ON/OFF]		X	Indicates [ON/OFF] condition of SET indicator.
EPS W/L [ON/OFF]		X	Indicates [ON/OFF] condition of EPS warning lamp.

*: The monitor will indicate "OFF" even though the brake warning lamp is on if either of the following conditions exist.

- The parking brake is engaged
- The brake fluid level is low

Trouble Diagnosis

INFOID:000000007403075

HOW TO PERFORM TROUBLE DIAGNOSIS

1. Confirm the symptom or customer complaint.
2. Perform preliminary check. Refer to "PRELIMINARY CHECK".
3. According to the symptom chart, repair or replace the cause of the malfunction. Refer to [DI-17, "Symptom Chart"](#).
4. Does the meter operate normally? If so, GO TO 5. If not, GO TO 2.
5. Inspection End.

PRELIMINARY CHECK

1. CHECK SELF-DIAGNOSIS OPERATION OF COMBINATION METER

Perform self-diagnosis of combination meter. Refer to [DI-14, "Self-Diagnosis Mode of Combination Meter"](#).

Does self-diagnosis mode operate?

YES >> GO TO 2.

NO >> Check power supply and ground circuit of combination meter. Refer to [DI-18, "Power Supply and Ground Circuit Inspection"](#).

2. CHECK COMBINATION METER (CONSULT)

Select "METER/M&A" on CONSULT and perform self-diagnosis of combination meter. Refer to [DI-15, "CONSULT Function \(METER/M&A\)"](#).

Self-diagnostic results content

No malfunction detected>> Refer to [DI-17, "Symptom Chart"](#).

Malfunction detected>> Refer to [DI-15, "CONSULT Function \(METER/M&A\)"](#).

Symptom Chart

INFOID:000000007403076

Symptom	Possible cause
Improper speedometer and odo/trip meter indication.	Refer to DI-19, "Vehicle Speed Signal Inspection" .
Improper tachometer indication.	Refer to DI-19, "Engine Speed Signal Inspection" .

COMBINATION METERS

< SERVICE INFORMATION >

Symptom	Possible cause
Improper fuel gauge indication.	Refer to DI-19. "Fuel Level Sensor Signal Inspection" .
Low-fuel warning lamp indication is irregular.	
Improper water temperature gauge indication.	Refer to DI-19. "Water Temperature Signal Inspection" .
Improper CVT position indication.	Refer to DI-51. "CVT Indicator Does Not Illuminate" .

Power Supply and Ground Circuit Inspection

INFOID:000000007403077

1. CHECK FUSE

Check for blown combination meter fuses.

Power source	Fuse No.
Battery	19
Ignition switch ON or START	14
Ignition switch ACC or ON	6

OK or NG

OK >> GO TO 2.

NG >> Be sure to eliminate cause of malfunction before installing new fuse. Refer to [PG-4](#).

2. CHECK POWER SUPPLY CIRCUIT

Check voltage between combination meter harness connector terminals and ground.

Terminals		(-)	Ignition switch position		
(+)	Terminal		OFF	ACC	ON
Combination meter connector	1	Ground	Battery voltage	Battery voltage	Battery voltage
	2		0V	0V	Battery voltage
	23		0V	Battery voltage	Battery voltage

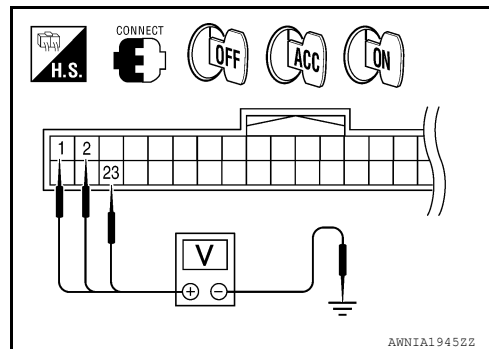

OK or NG

OK >> GO TO 3.

NG >> Repair harness or connector.

3. CHECK GROUND CIRCUIT

- Turn ignition switch OFF.
- Disconnect combination meter connector.
- Check continuity between combination meter harness connector terminals and ground.

Combination meter connector	Terminal	Ground	Continuity
M24	3		Yes
	21		
	22		

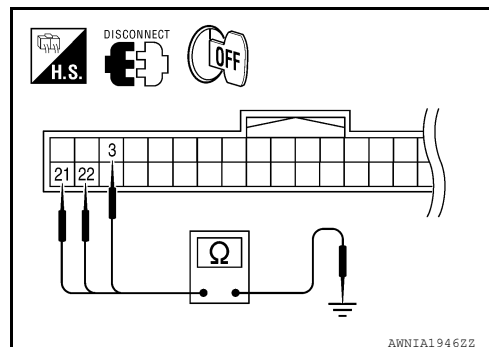

OK or NG

OK >> Replace combination meter. Refer to [IP-12. "Removal and Installation"](#).

NG >> Repair harness or connector.

COMBINATION METERS

< SERVICE INFORMATION >

Vehicle Speed Signal Inspection

INFOID:000000007403078

Symptom:

- Improper speedometer and odo/trip meter indication.
- Display VEHICLE SPEED CIRC [B2205] at the result of self-diagnosis for combination meter.

1. CHECK COMBINATION METER INPUT SIGNAL

1. Start engine and select "METER/M&A" on CONSULT.
2. Using "SPEED METER" on "DATA MONITOR", compare the value of "DATA MONITOR" with speedometer pointer of combination meter.

OK or NG

- OK >> Perform ABS actuator and electric unit (control unit) self-diagnosis. Refer to [BRC-24. "CONSULT Function \(ABS\)".](#)
- NG >> Replace combination meter. Refer to [IP-12. "Removal and Installation".](#)

Engine Speed Signal Inspection

INFOID:000000007403079

Symptom: Improper tachometer indication.

1. CHECK COMBINATION METER INPUT SIGNAL

1. Start engine and select "METER/M&A" on CONSULT.
2. Using "TACHO METER" on "DATA MONITOR", compare the value of "DATA MONITOR" with tachometer pointer of combination meter.

OK or NG

- OK >> • Perform ECM self-diagnosis. Refer to [EC-1237. "CONSULT Function \(ENGINE\)"](#) (with QR25DE).
- Perform ECM self-diagnosis. Refer to [EC-132. "CONSULT Function \(ENGINE\)"](#) (with MR20DE for California).
 - Perform ECM self-diagnosis. Refer to [EC-692. "CONSULT Function \(ENGINE\)"](#) (with MR20DE except California).
- NG >> Replace combination meter. Refer to [IP-12. "Removal and Installation".](#)

Water Temperature Signal Inspection

INFOID:000000007403080

Symptom: Improper water temperature gauge indication.

1. CHECK COMBINATION METER INPUT SIGNAL

1. Start engine and select "METER/M&A" on CONSULT.
2. Run the engine at different temperatures and compare water temperature with "W TEMP METER" of "DATA MONITOR". Indication should be as follows:

High: 130°C (266°F)
Normal: 70 - 105°C (158 - 221°F)
Cold: Less than 50°C (122°F)

OK or NG

- OK >> • Perform ECM self-diagnosis. Refer to [EC-1237. "CONSULT Function \(ENGINE\)"](#) (with QR25DE).
- Perform ECM self-diagnosis. Refer to [EC-132. "CONSULT Function \(ENGINE\)"](#) (with MR20DE for California).
 - Perform ECM self-diagnosis. Refer to [EC-692. "CONSULT Function \(ENGINE\)"](#) (with MR20DE except California).
- NG >> Replace combination meter. Refer to [IP-12. "Removal and Installation".](#)

Fuel Level Sensor Signal Inspection

INFOID:000000007403081

Symptom:

- Improper fuel gauge indication.
- Low-fuel warning lamp indication is irregular.

NOTE:

COMBINATION METERS

< SERVICE INFORMATION >

The following symptoms do not indicate a malfunction.

- Depending on vehicle position or driving circumstance, the fuel level in the tank shifts and the indication may fluctuate.
- If the vehicle is fueled with the ignition switch ON, the indication will update slowly.
- If the vehicle is tilted when the ignition switch is turned ON, fuel in the tank may flow to one direction resulting in a change of reading.

1. CHECK COMBINATION METER INPUT SIGNAL

1. Select "METER/M&A" on CONSULT.
2. Using "FUEL METER" on "DATA MONITOR", compare the value of "DATA MONITOR" with fuel gauge indication of combination meter.

Fuel gauge indication (approx. segments)	Reference value of data monitor [lit.]
Full (13)	Approx. 55
3/4 (10)	Approx. 38
1/2 (7)	Approx. 25
1/4 (4)	Approx. 13
Empty (0)	Approx. 4

OK or NG

OK >> GO TO 2.

NG >> Replace combination meter. Refer to [IP-12. "Removal and Installation"](#).

2. CHECK HARNESS CONNECTOR

1. Turn ignition switch OFF.
2. Check combination meter and fuel level sensor unit terminals (meter-side and harness-side) for poor connection.

OK or NG

OK >> GO TO 3.

NG >> Repair or replace terminals or connectors.

3. CHECK FUEL LEVEL SENSOR UNIT CIRCUIT

1. Disconnect combination meter connector and fuel level sensor unit connector.
2. Check continuity between combination meter harness connector (A) and fuel level sensor unit and fuel pump harness connector (B).

A		B		Continuity
Connector	Terminal	Connector	Terminal	
M24	8	B48	2	Yes

3. Check continuity between combination meter harness connector (A) and ground.

A		Ground	Continuity
Connector	Terminal		
M24	8		No

OK or NG

OK >> GO TO 4.

NG >> Repair harness or connector.

4. CHECK FUEL LEVEL SENSOR UNIT GROUND CIRCUIT

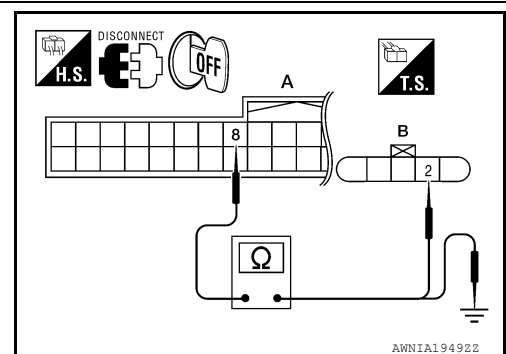

COMBINATION METERS

< SERVICE INFORMATION >

1. Check continuity between combination meter harness connector (A) and fuel level sensor unit and fuel pump harness connector (B).

A		B		Continuity
Connector	Terminal	Connector	Terminal	
M24	4	B48	5	Yes

2. Check continuity between combination meter harness connector (A) and ground.

A		Ground	Continuity
Connector	Terminal		
M24	4		No

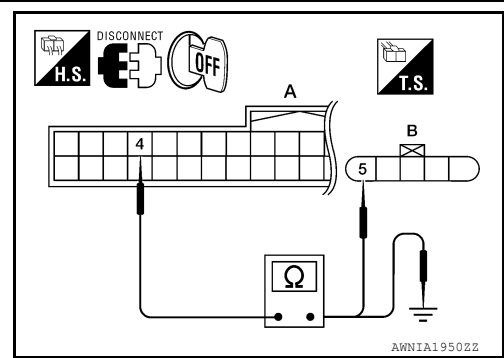

OK or NG

- OK >> GO TO 5.
- NG >> Repair harness or connector.

5. CHECK FUEL LEVEL SENSOR UNIT

Check fuel level sensor unit. Refer to [DI-22. "Electrical Component Inspection"](#).

OK or NG

- OK >> Check fuel level sensor unit installation, and check whether the float arm interferes or binds with any of the internal components in the fuel tank. Repair or replace malfunctioning part, if necessary.
- NG >> Replace fuel level sensor unit.

Fuel Gauge Fluctuates, Indicates Wrong Value, or Varies

INFOID:000000007403082

1. CHECK FUEL GAUGE FLUCTUATION

Test drive vehicle to see if gauge fluctuates only during driving or at the instant of stopping.

Does the indication value vary only during driving or at the at the instant of stopping?

- YES >> The gauge fluctuation may be caused by fuel level change in the fuel tank. Condition is normal.
- NO >> Ask the customer about the situation when the symptom occurs in detail, and perform the trouble diagnosis.

Fuel Gauge Does Not Move to Full-position

INFOID:000000007403083

1. OBSERVE FUEL GAUGE

Does it take a long time for the indication to move to FULL position?

YES or NO

- YES >> GO TO 2.
- NO >> GO TO 3.

2. IDENTIFY FUELING CONDITION

Was the vehicle fueled with the ignition switch ON?

YES or NO

- YES >> Be sure to fuel the vehicle with the ignition switch OFF. Otherwise, it will take a long time to move to FULL position because of the characteristic of the fuel gauge.
- NO >> GO TO 3.

3. OBSERVE VEHICLE POSITION

Is the vehicle parked on an incline?

YES or NO

- YES >> Check the fuel level indication with vehicle on a level surface.
- NO >> GO TO 4.

COMBINATION METERS

< SERVICE INFORMATION >

4. OBSERVE FUEL GAUGE INDICATOR

During driving, does the fuel gauge indication move gradually toward EMPTY position?

YES or NO

- YES >> Check the components. Refer to [DI-22. "Electrical Component Inspection"](#).
- NO >> The float arm may interfere or bind with any of the components in the fuel tank.

DTC [U1000] CAN Communication Circuit

INFOID:000000007403084

Symptom: Display CAN COMM CIRC [U1000] at the result of self-diagnosis for combination meter.

1. CHECK CAN COMMUNICATION

Select "SELF-DIAG RESULTS" mode for "METER/M&A" with CONSULT.

>> Go to "CAN SYSTEM". Refer to [LAN-42. "Diagnosis Procedure"](#).

Electrical Component Inspection

INFOID:000000007403085

FUEL LEVEL SENSOR UNIT CHECK

For removal, refer to [FL-6. "Removal and Installation"](#).

Check Fuel Level Sensor Unit and Fuel Pump
Check resistance between terminals 2 and 5.

Terminals		Float position mm (in)			Resistance value (Ω) (Approx.)
2	5	1*	Full	144.4 (5.69)	5
		2*	Empty	11.6 (0.46)	

1* and 2*: When float rod is in contact with stopper.

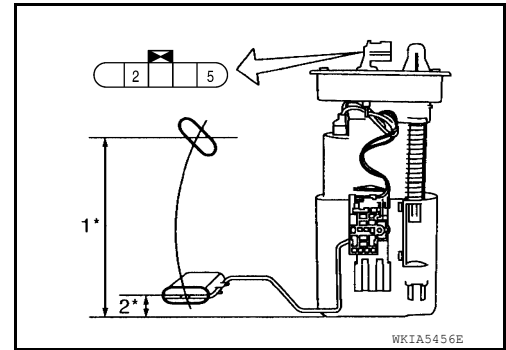

Check Fuel Level Sensor Unit and Fuel Pump Harness
Check continuity at the following terminals.

Terminal	Continuity
2 - Signal terminal (A)	Yes
5 - Ground terminal (B)	

- If the results of check are NG, replace fuel pump assembly. If the results of check are OK, replace fuel level sensor unit.

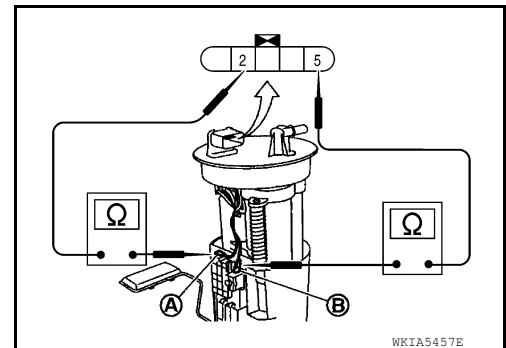

Removal and Installation

INFOID:000000007403086

REMOVAL

1. Remove instrument lower panel LH screw, position instrument lower panel LH to disconnect diagnostic connector and hood release cable, and then remove instrument lower panel LH.

COMBINATION METERS

< SERVICE INFORMATION >

2. Remove steering lock escutcheon (1).
3. Remove steering column cover screws (A), then remove steering column upper cover and lower cover (2).

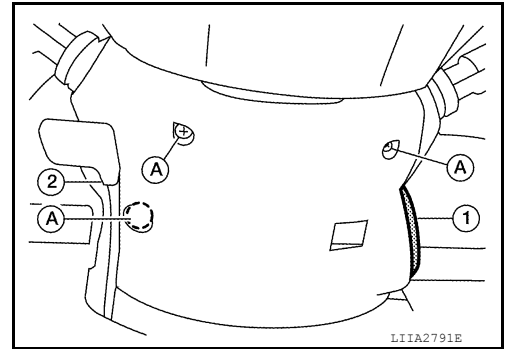

4. Disengage the metal clips, and then remove cluster lid A.
5. Remove the combination meter screws (A), pull out the combination meter (1) to disconnect the connector, remove the combination meter (1).

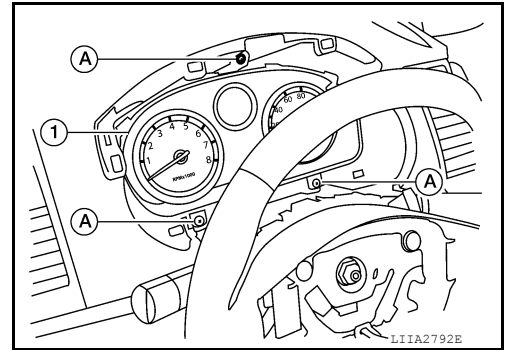

INSTALLATION

Installation is in the reverse order of removal.

A
B
C
D
E
F
G
H
I
J
L
M
N
O
P

DI

DOUBLE METERS

< SERVICE INFORMATION >

DOUBLE METERS

System Description

INFOID:000000007403087

DOUBLE METER

Oil pressure gauge and G-force gauge are controlled by the double meter.

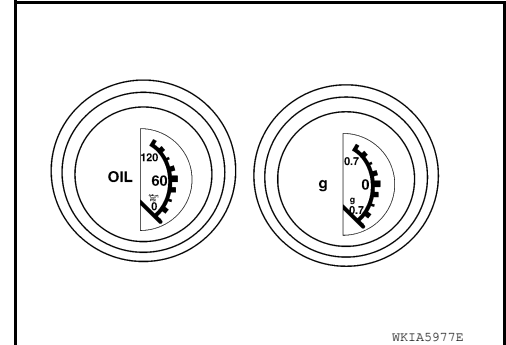

Oil Pressure Warning Lamp

The oil pressure warning lamp is controlled by the double meter. When the oil pressure is less than 4.52 psi (0.318 kg/cm²), the double meter sends a ground signal to the IPDM E/R. The IPDM E/R then sends a signal to the combination meter via CAN communication and the oil pressure warning lamp is turned on. When the oil pressure is greater than 6.5 psi (0.457 kg/cm²) the warning lamp turns off.

POWER SUPPLY AND GROUND CIRCUIT

Power is supplied at all times

- through 10A fuse [No. 19, located in the fuse block (J/B)]
- to double meter terminal 7 and
- to combination meter terminal 1.

With the ignition switch in the ON or START position, power is supplied

- through 10A fuse [No. 14, located in the fuse block (J/B)]
- to double meter terminal 8 and
- to combination meter terminal 2.

With the ignition switch in the ACC or ON position, power is supplied

- through 10A fuse [No. 6, located in the fuse block (J/B)]
- to combination meter terminal 23.

Ground is supplied

- to double meter terminals 9 and 10 and
- to combination meter terminals 3 and 21
- through body grounds M57 and M61.

OIL PRESSURE GAUGE

The oil pressure gauge indicates engine oil pressure.

With the ignition switch in the ON or START position, power is supplied

- through double meter terminal 3
- to oil pressure sensor terminal 3.

Ground is supplied

- through double meter terminal 5
- to oil pressure sensor terminal 1.

Double meter receives oil pressure signal from oil pressure sensor

- through oil pressure sensor terminal 2
- to double meter terminal 4.

G-FORCE GAUGE

The G-force gauge indicates the longitudinal acceleration and deceleration G-forces while driving. The indication is based on a calculation using the speed input supplied by the combination meter via CAN communication. The gauge does not indicate cornering G-forces.

DOUBLE METERS

< SERVICE INFORMATION >

Wiring Diagram - 2METER -

INFOID:00000007403088

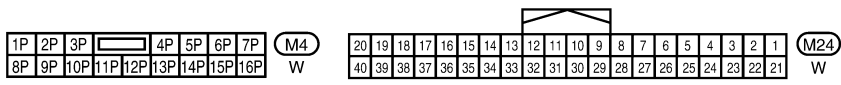
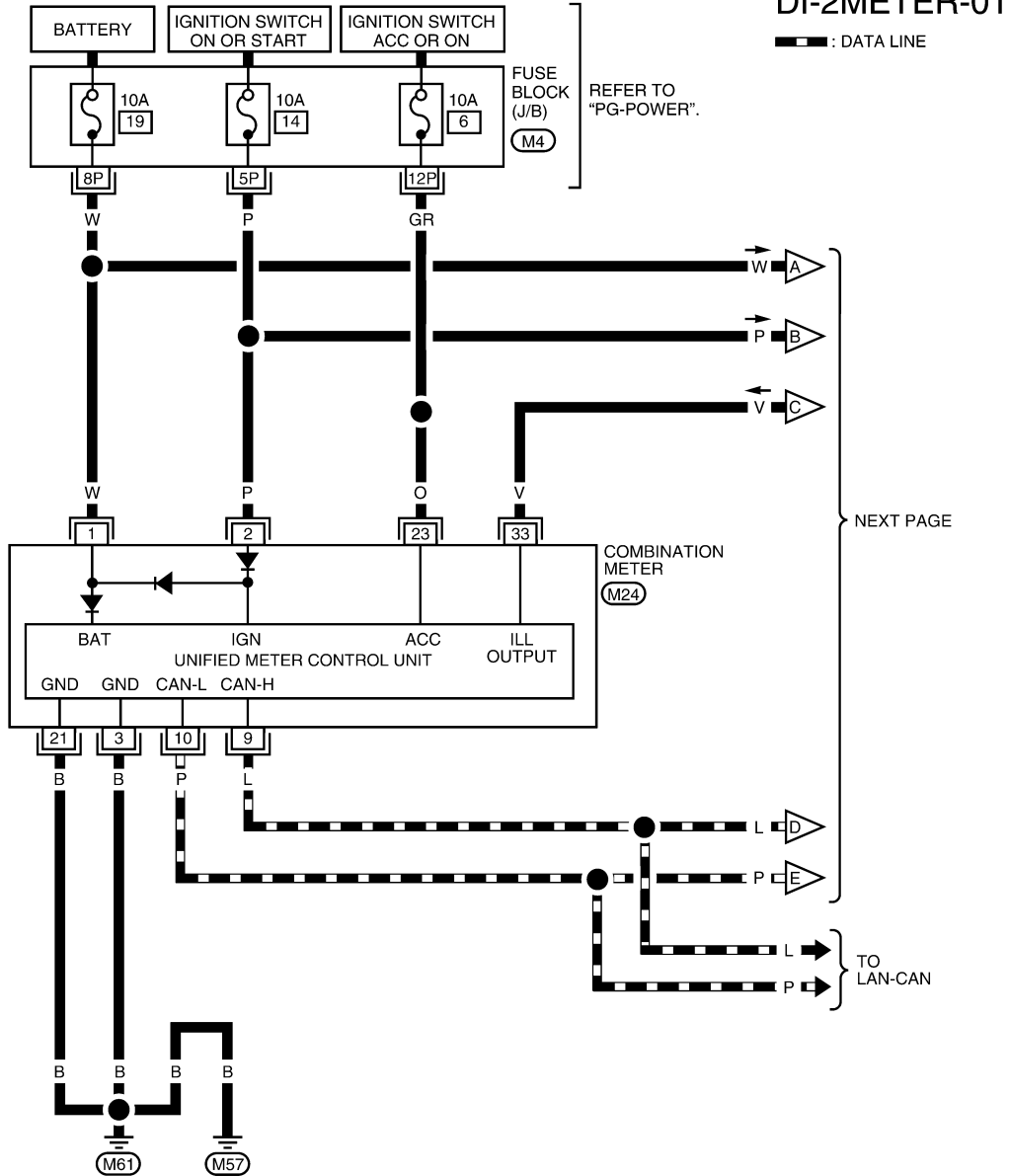

A
B
C
D
E
F
G
H
I
J
K
L
M
N
O
P

DI

DOUBLE METERS

< SERVICE INFORMATION >

DI-2METER-02

— : DATA LINE

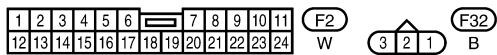
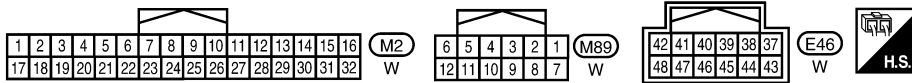
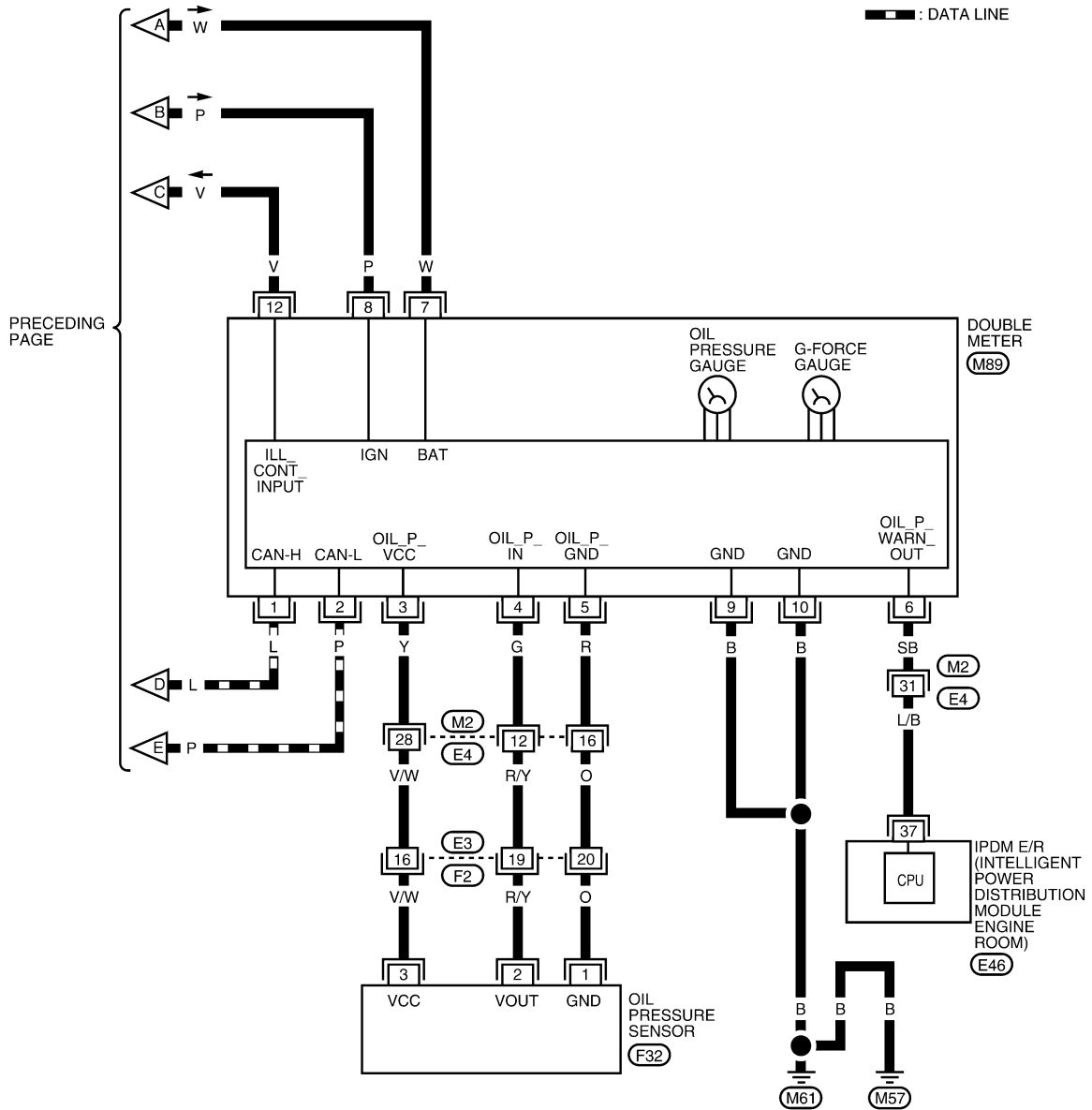

AANWA0222GB

DOUBLE METERS

< SERVICE INFORMATION >

Terminal and Reference Value for Double Meter

INFOID:000000007403089

Terminal No.	Wire color	Item	Condition		Voltage (V) (Approx.)
			Ignition switch	Operation or condition	
1	L	CAN-H	—	—	—
2	P	CAN-L	—	—	—
3	Y	Oil pressure sensor power supply	ON	—	5.5
4	G	Oil pressure sensor signal	ON	When ignition switch is in the ON position. (Engine stopped)	0.5
				Engine running. [When the oil pressure is 60 psi (4.22 kg/cm ²)]	2.5
5	R	Oil pressure sensor ground	ON	—	0
6	SB	Oil pressure warn out	ON	Engine oil pressure is below 4.52 psi (0.318 kg/cm ²)	0.5
				Engine oil pressure is above 6.5 psi (0.457 kg/cm ²)	Battery voltage
7	W	Battery power supply	OFF	—	Battery voltage
8	P	Ignition switch ON or START	ON	—	Battery voltage
9	B	Ground	ON	—	0
10					
12	V	Illumination control	—	—	Refer to LT-99. "System Description" .

Terminal and Reference Value for Combination Meter

INFOID:000000007605175

Terminal No.	Wire color	Item	Condition		Reference value (V) (Approx.)
			Ignition switch	Operation or condition	
1	W	Battery power supply	OFF	—	Battery voltage
2	P	Ignition switch ON or START	ON	—	Battery voltage
3	B	Ground (power)	—	—	0
4	B	Fuel level sensor ground (-)	ON	—	0
8	LG	Fuel level sensor signal (+)	—	—	Refer to DI-22. "Electrical Component Inspection" .
9	L	CAN-H	—	—	—
10	P	CAN-L	—	—	—
13	V	Illumination control switch (LED)	—	—	Refer to LT-99. "System Description" .
16	SB	Immobilizer/security indicator input	OFF	Security indicator ON	0
				Security indicator OFF	Battery voltage
18	G	Seat belt buckle switch RH	ON	Unfastened (ON)	0
				Fastened (OFF)	Battery voltage
21	B	Ground (illumination)	—	—	0
22					
23	O	Ignition switch ACC or ON	ON	—	Battery voltage
24	GR	Parking Brake switch	ON	Parking brake applied	0
				Parking brake released	Battery voltage

DOUBLE METERS

< SERVICE INFORMATION >

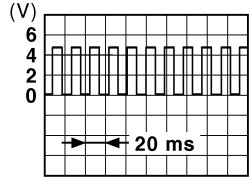
Ter- mi- nal No.	Wire color	Item	Condition		Reference value (V) (Approx.)
			Ignition switch	Operation or condition	
25	V	Brake fluid level switch	ON	Brake fluid level low	0
				Brake fluid level normal	Battery voltage
26	O	Seat belt buckle switch LH	ON	Unfastened (ON)	0
				Fastened (OFF)	Battery voltage
28	R	Washer fluid level switch (Canada models)	ON	Washer fluid level low	0
				Washer fluid level normal	Battery voltage
29	W	O/D OFF switch	ON	O/D OFF switch pressed	0
				O/D OFF switch released	Battery voltage
31	O	Vehicle speed signal output (8-pulse)	ON	Speedometer operated [When vehicle speed is approx. 40 km/h (25 MPH)]	<p>NOTE: Maximum voltage may be 12 V due to specifications (connected units).</p>  <p style="text-align: right;"><small>PKIC0643E</small></p>
32	BR	Generator	ON	Generator voltage low	0
				Generator voltage normal	Battery voltage
33	V	Illumination output to double meter	—	—	Refer to LT-99 , "System Description".
34	LG	Ambient sensor power	ON	—	5
35	B	Ambient sensor ground	ON	—	0 - 5 (Based on ambient temperature)
37*	LG	Manual mode signal	ON	Manual mode switch ON	0
				Manual mode switch OFF	Battery voltage
38*	SB	Not manual mode signal	ON	Manual mode switch ON	0
				Manual mode switch OFF	Battery voltage
39*	W	CVT steering shift up signal	ON	<ul style="list-style-type: none"> Manual mode switch ON Steering shift up operation 	0
				Other than above	Battery voltage
40*	Y	CVT steering shift down sig- nal	ON	<ul style="list-style-type: none"> Manual mode switch ON Steering shift down operation 	0
				Other than above	Battery voltage

*: With QR25DE

CONSULT Function (METER/M&A)

INFOID:000000007605176

CONSULT can display each diagnostic item using the diagnostic test modes shown following.

METER diagnosis mode	Description
SELF DIAGNOSTIC RESULT	Displays combination meter self-diagnosis results.
DATA MONITOR	Displays combination meter input/output data in real time.
CAN DIAG SUPPORT MNTR	The result of transmit/receive diagnosis of CAN communication can be read.

SELF-DIAGNOSTIC RESULTS

Display Item List

DOUBLE METERS

< SERVICE INFORMATION >

CONSULT display	Malfunction	Reference page
CAN COMM CIRC [U1000]	Malfunction is detected in CAN communication lines. CAUTION: Even when there is no malfunction on CAN communication system, malfunction may be misinterpreted when battery has low voltage (when maintaining 7 - 8 V for about 2 seconds) or 10A fuse [No. 14, located in the fuse block (J/B)] is removed.	DI-22
VEHICLE SPEED CIRC [B2205]	Malfunction is detected when an erroneous speed signal is input. CAUTION: Even when there is no malfunction on speed signal system, malfunctions may be misinterpreted when battery has low voltage (when maintaining 7 - 8 V for about 2 seconds).	DI-19

NOTE:

“TIME” indicates the following.

- 0: Indicates that a malfunction is detected at present.
- 1-63: Indicates that a malfunction was detected in the past. (Displays number of ignition switch OFF → ON cycles after malfunction is detected. Self-diagnostic result is erased when “63” is exceeded.)

DATA MONITOR

Display Item List

Display item [Unit]	MAIN SIGNALS	SELECTION FROM MENU	Contents
SPEED METER [km/h]	X	X	The value of vehicle speed signal, which is input from ABS actuator and electric unit (control unit).
SPEED OUTPUT [km/h]	X	X	The value of vehicle speed signal, which is transmitted to each unit with CAN communication.
TACHO METER [rpm]	X	X	The value of engine speed signal, which is input from ECM.
W TEMP METER [°C]	X	X	The value of engine coolant temperature signal, which is input from ECM.
FUEL METER [lit.]	X	X	The value, which processes a resistance signal from fuel gauge.
FUEL W/L [ON/OFF]	X	X	Indicates [ON/OFF] condition of low-fuel warning lamp.
C-ENG W/L [ON/OFF]		X	Indicates [ON/OFF] condition of malfunction indicator lamp (MIL).
AIR PRES W/L		X	Indicates [ON/OFF] condition of low tire pressure warning lamp.
SEAT BELT W/L		X	Indicates [ON/OFF] condition of seat belt warning lamp.
BUZZER [ON/OFF]	X	X	Indicates [ON/OFF] condition of buzzer.
DOOR W/L [ON/OFF]		X	Indicates [ON/OFF] condition of door warning lamp.
HI-BEAM IND [ON/OFF]		X	Indicates [ON/OFF] condition of high beam indicator lamp.
TURN IND [ON/OFF]		X	Indicates [ON/OFF] condition of turn indicator.
OIL W/L [ON/OFF]		X	Indicates [ON/OFF] condition of oil pressure warning lamp.
LIGHT IND [ON/OFF]		X	Indicates [ON/OFF] condition of the light indicator lamp.
VDC/TCS IND [ON/OFF]		X	Indicates [ON/OFF] condition of VDC OFF indicator lamp.
ABS W/L [ON/OFF]		X	Indicates [ON/OFF] condition of ABS warning lamp.
SLIP IND [ON/OFF]		X	Indicates [ON/OFF] condition of SLIP indicator lamp.
BRAKE W/L [ON/OFF]		X	Indicates [ON/OFF] condition of brake warning lamp.*
KEY G/Y W/L [ON/OFF]		X	Indicates [ON/OFF] condition of KEY warning lamp (green).
KEY R W/L [ON/OFF]		X	Indicates [ON/OFF] condition of KEY warning lamp (red).
KEY KNOB W/L [ON/OFF]		X	Indicates [ON/OFF] condition of LOCK warning lamp.
O/D OFF SW [ON/OFF]		X	Indicates [ON/OFF] condition of O/D OFF switch.
P RANGE IND [ON/OFF]	X	X	Indicates [ON/OFF] condition of CVT shift P range indicator.

DOUBLE METERS

< SERVICE INFORMATION >

Display item [Unit]	MAIN SIGNALS	SELECTION FROM MENU	Contents
R RANGE IND [ON/OFF]	X	X	Indicates [ON/OFF] condition of CVT shift R range indicator.
N RANGE IND [ON/OFF]	X	X	Indicates [ON/OFF] condition of CVT shift N range indicator.
D RANGE IND [ON/OFF]	X	X	Indicates [ON/OFF] condition of CVT shift D range indicator.
L RANGE IND [ON/OFF]	X	X	Indicates [ON/OFF] condition of CVT shift L range indicator.
M RANGE SW [ON/OFF]	X	X	Indicates [ON/OFF] condition of manual mode range switch.
NM RANGE SW [ON/OFF]	X	X	Indicates [ON/OFF] condition of except manual mode range switch.
AT-M IND [ON/OFF]	X	X	Indicates [ON/OFF] condition of manual mode indicator.
AT-M GEAR [1 - 8]	X	X	Indicates [1 - 8] condition of manual mode gear position.
SPORT IND [ON/OFF]		X	Indicates [ON/OFF] condition of O/D OFF indicator.
ST SFT UP SW [ON/OFF]		X	Indicates [ON/OFF] condition of steering shift up switch.
ST SFT DWN SW [ON/OFF]		X	Indicates [ON/OFF] condition of steering shift down switch.
CRUISE IND [ON/OFF]		X	Indicates [ON/OFF] condition of CRUISE indicator.
SET IND [ON/OFF]		X	Indicates [ON/OFF] condition of SET indicator.
EPS W/L [ON/OFF]		X	Indicates [ON/OFF] condition of EPS warning lamp.

*: The monitor will indicate "OFF" even though the brake warning lamp is on if either of the following conditions exist.

- The parking brake is engaged
- The brake fluid level is low

Trouble Diagnosis

INFOID:000000007403092

HOW TO PERFORM TROUBLE DIAGNOSIS

1. Confirm the symptom or customer complaint.
2. Perform preliminary check. Refer to "PRELIMINARY CHECK".
3. According to the symptom chart, repair or replace the cause of the symptom. Refer to [DI-30. "Symptom Chart"](#).
4. Does the double meter operate normally? If so, GO TO 5. If not, GO TO 2.
5. Inspection End.

PRELIMINARY CHECK

1. CHECK COMBINATION METER (CONSULT)

Select "METER/M&A" on CONSULT and perform self-diagnosis of combination meter. Refer to [DI-15. "CONSULT Function \(METER/M&A\)"](#).

Self-diagnostic results content

No malfunction detected>>Refer to [DI-30. "Symptom Chart"](#).

Malfunction detected>>Refer to [DI-15. "CONSULT Function \(METER/M&A\)"](#).

Symptom Chart

INFOID:000000007403093

Symptom	Possible cause
Improper oil pressure gauge indication.	Refer to DI-31. "Oil Pressure Sensor Inspection" .
Improper G-force gauge indication.	Replace double meter. Refer to DI-33. "Removal and Installation" .
Double meter is inoperative.	<ul style="list-style-type: none"> • Refer to DI-30. "Power Supply and Ground Circuit Inspection". • Replace double meter. Refer to DI-33. "Removal and Installation".

Power Supply and Ground Circuit Inspection

INFOID:000000007403094

1. CHECK FUSES

DOUBLE METERS

< SERVICE INFORMATION >

Check for blown double meter fuses.

Power source	Fuse No.
Battery	19
Ignition switch ON or START	14

OK or NG

OK >> GO TO 2.

NG >> If fuse is blown, be sure to eliminate cause of malfunction before installing new fuse. Refer to [PG-4](#).

2. CHECK POWER SUPPLY CIRCUIT

1. Disconnect the double meter connector.
2. Check voltage between double meter harness connector terminals and ground.

Terminals		(-)	Ignition switch position		
(+)	Connector		Terminal	OFF	ON
M89	7	Ground	Battery voltage	Battery voltage	Battery voltage
	8		0V	Battery voltage	Battery voltage

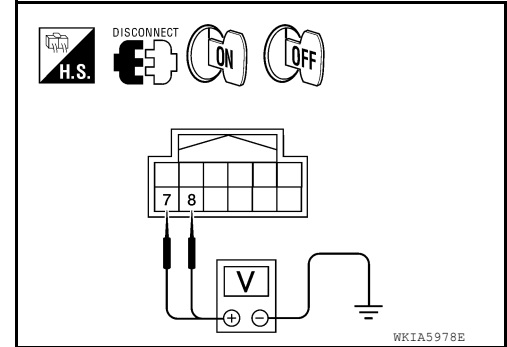

OK or NG

OK >> GO TO 3.

NG >> Check harness for open between double meter and fuse.

3. CHECK GROUND CIRCUIT

1. Turn ignition switch OFF.
2. Check continuity between double meter harness connector M89 terminals 9, 10 and ground.

Continuity should exist.

OK or NG

OK >> Inspection End.

NG >> Check harness or connector.

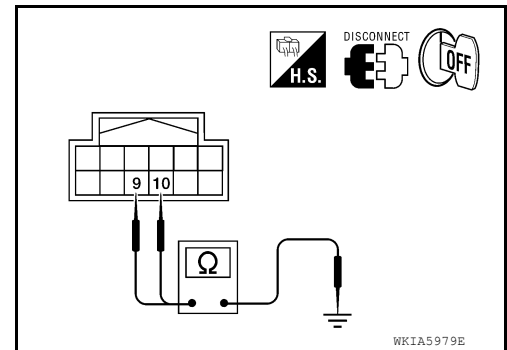

INFOID:000000007403095

Oil Pressure Sensor Inspection

1. CHECK OIL PRESSURE SENSOR SIGNAL

1. Turn ignition switch ON.
2. Check voltage between double meter harness connector M89 terminal 4 and ground.

Terminals		(-)	Condition	Voltage (Approx.)
(+)	Connector			
M89	4	Ground	When ignition switch is in ON position. (Engine stopped.)	0.5V
			Engine running. [When the oil pressure is 60 psi (4.22 kg/cm ²)]	2.5V

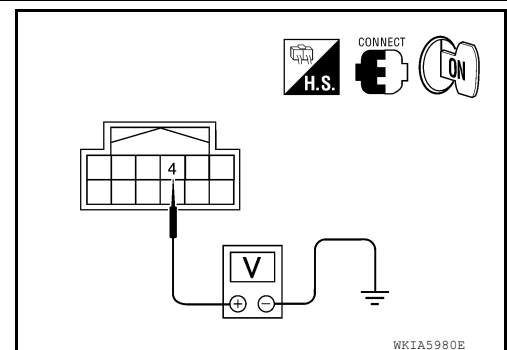

DOUBLE METERS

< SERVICE INFORMATION >

OK or NG

- OK >> Replace double meter. Refer to [DI-33, "Removal and Installation"](#).
- NG >> GO TO 2.

2. CHECK OIL PRESSURE SENSOR POWER SUPPLY

Check voltage between double meter harness connector M89 terminal 3 and ground.

Approx. 5.5V

OK or NG

- OK >> GO TO 3.
- NG >> Check oil pressure sensor power supply circuit for short to ground. If OK then replace double meter. Refer to [DI-33, "Removal and Installation"](#).

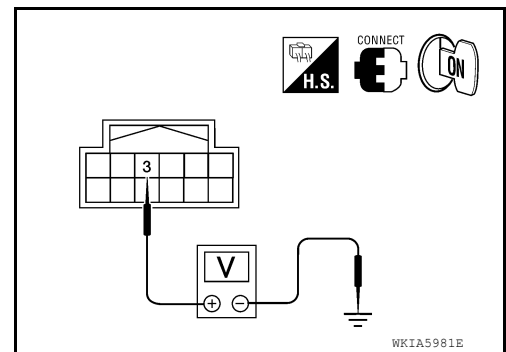

3. CHECK OIL PRESSURE SENSOR POWER SUPPLY CIRCUIT

1. Turn ignition switch OFF.
2. Disconnect double meter and oil pressure sensor connectors.
3. Check continuity between double meter harness connector M89 (A) terminal 3 and oil pressure sensor harness connector F32 (B) terminal 3.

Continuity should exist.

OK or NG

- OK >> GO TO 4.
- NG >> Repair harness or connector between double meter and oil pressure sensor.

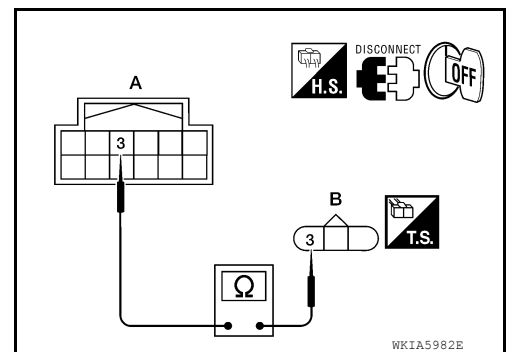

4. CHECK OIL PRESSURE SENSOR SIGNAL CIRCUIT

1. Check continuity between double meter harness connector M89 (B) terminal 4 and oil pressure sensor harness connector F32 (A) terminal 2.

Continuity should exist.

2. Check continuity between double meter harness connector M89 (B) terminal 4 and ground.

Continuity should not exist.

OK or NG

- OK >> GO TO 5.
- NG >> Repair harness or connector between double meter and oil pressure sensor.

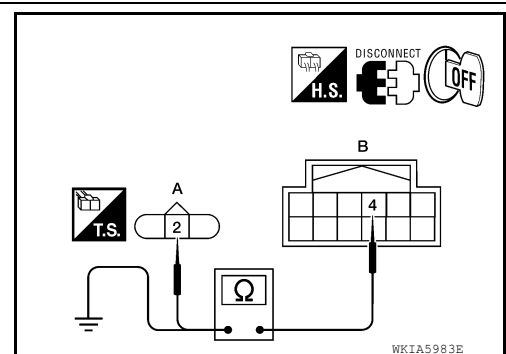

5. CHECK OIL PRESSURE SENSOR GROUND CIRCUIT

Check continuity between double meter harness connector M89 (A) terminal 5 and oil pressure sensor harness connector F32 (B) terminal 1.

Continuity should exist.

OK or NG

- OK >> Replace double meter (oil pressure gauge does not move).
- OK >> Replace oil pressure sensor (oil pressure gauge moves but reads incorrectly).
- NG >> Repair harness or connector between double meter and oil pressure sensor.

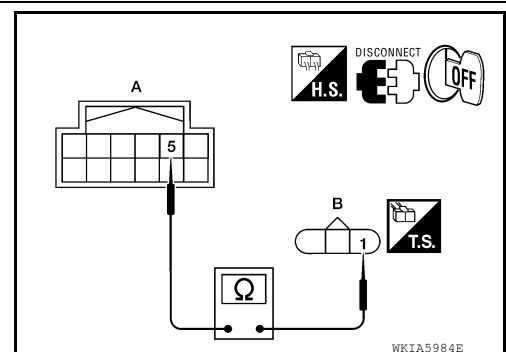

DOUBLE METERS

< SERVICE INFORMATION >

Removal and Installation

INFOID:000000007403096

COMPONENTS

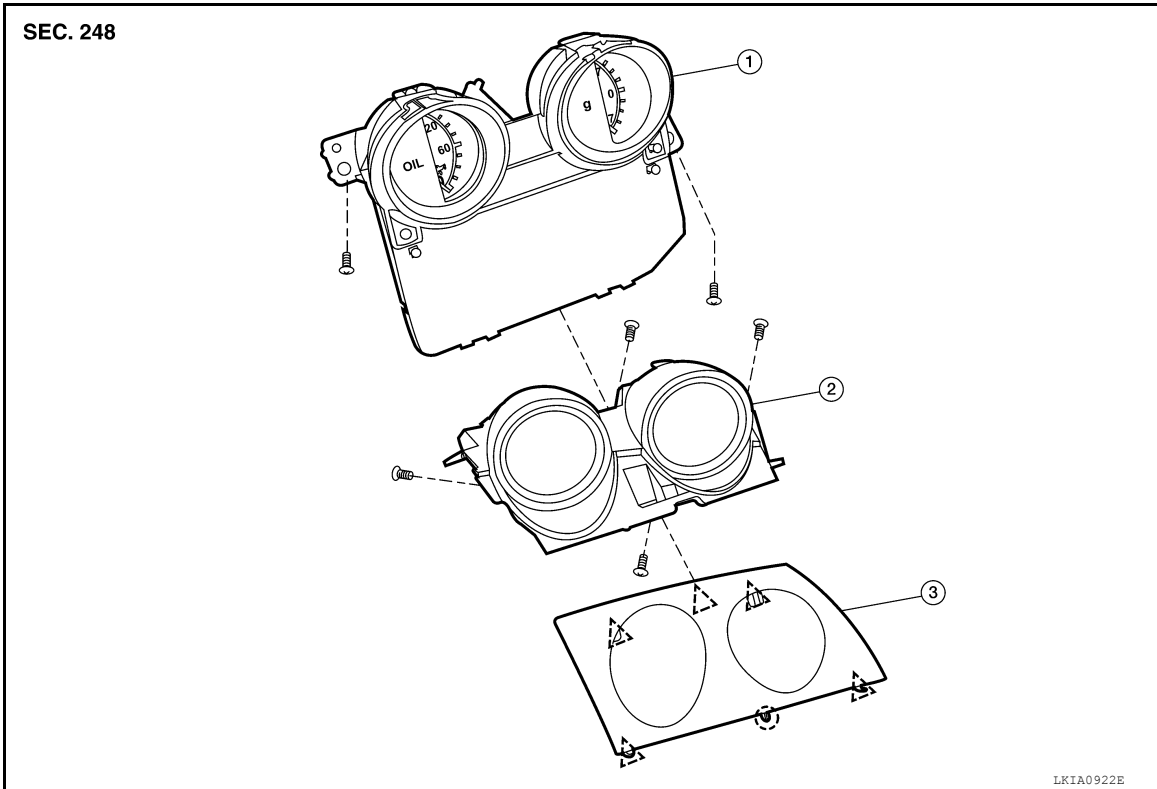

1. Double meter

2. Upper housing

3. Double meter finisher

 Clip

 Pawl

REMOVAL

1. Carefully remove the double meter assembly (1) using suitable tool.

CAUTION:

Wrap suitable tool with clean shop cloth to prevent damage to the instrument panel.

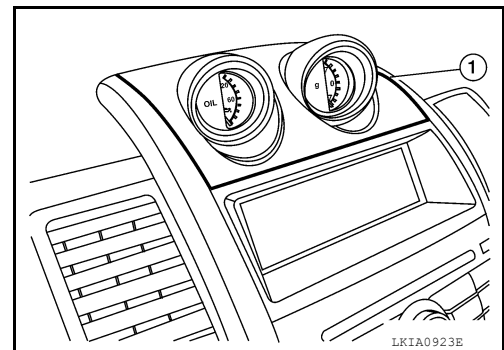

2. Disconnect the double meter assembly connector (1) and remove the double meter assembly (2).

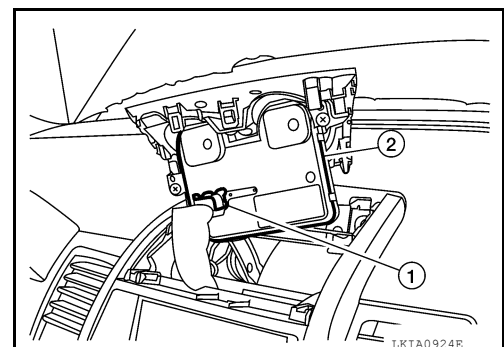

INSTALLATION

A
B
C
D
E
F
G
H
I
J

DI

L
M
N
O
P

DOUBLE METERS

< SERVICE INFORMATION >

Installation is in the reverse order of removal.

WARNING LAMPS

< SERVICE INFORMATION >

WARNING LAMPS

Schematic

INFOID:000000007403097

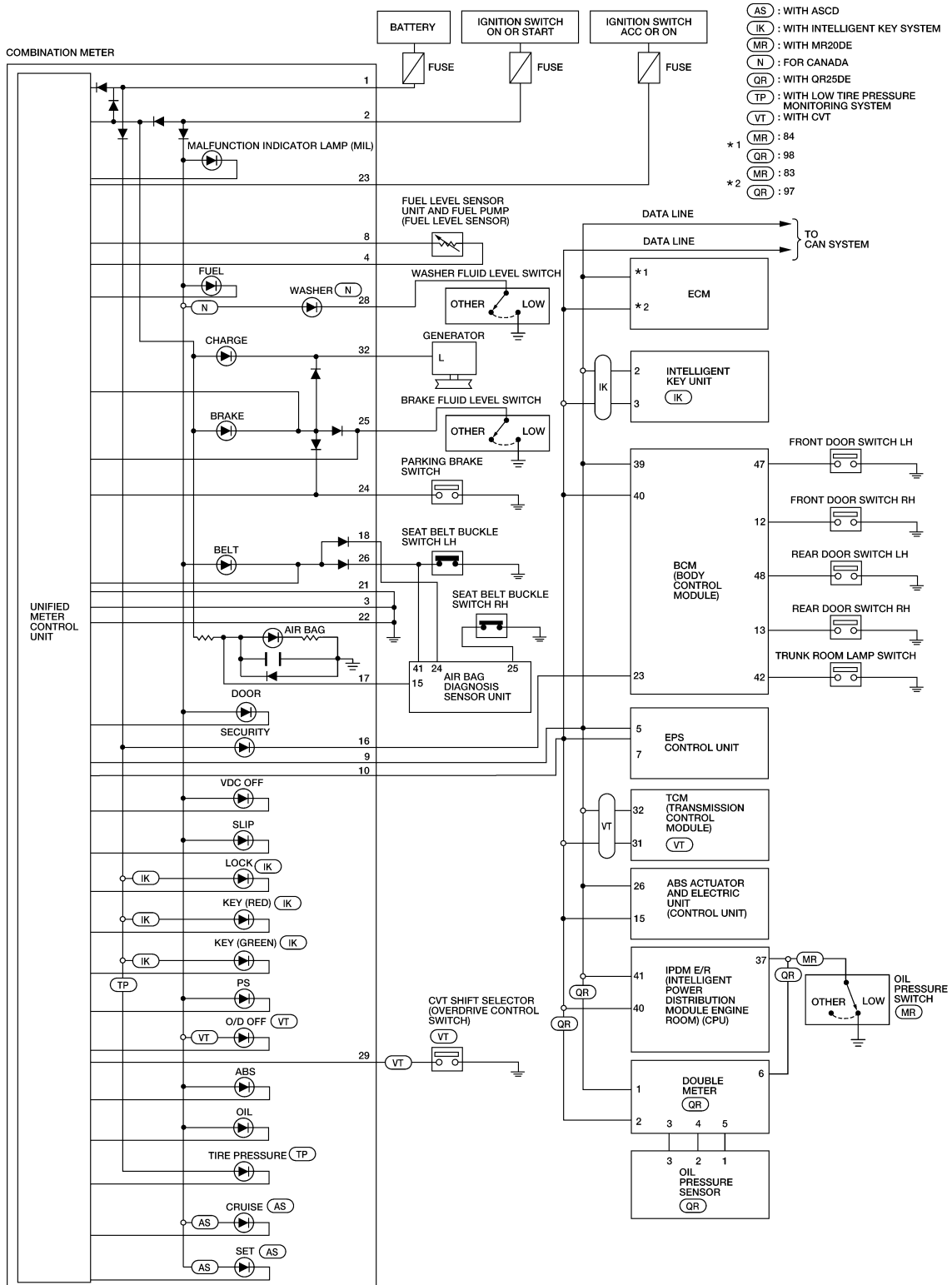

AANWA0459GB

A
B
C
D
E
F
G
H
I
J
DI
L
M
N
O
P

WARNING LAMPS

< SERVICE INFORMATION >

Wiring Diagram - WARN -

INFOID:000000007403098

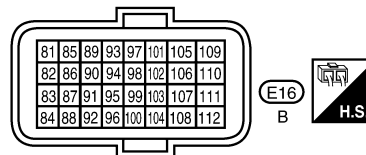
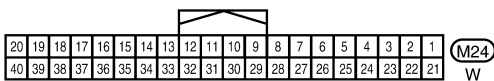
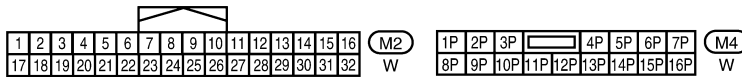
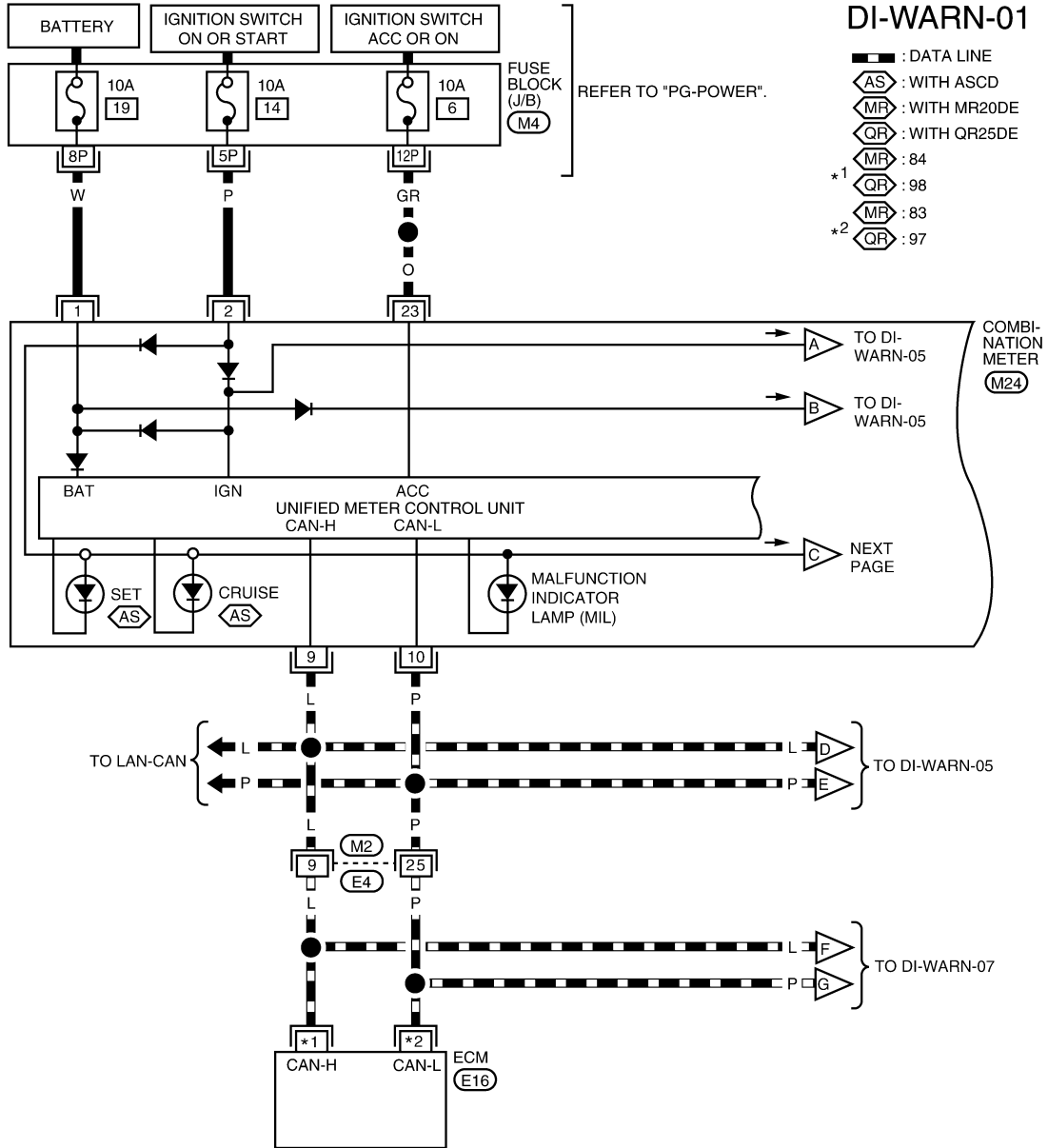

ABNWA0879GB

WARNING LAMPS

< SERVICE INFORMATION >

DI-WARN-02

MR : WITH MR20DE
 N : FOR CANADA

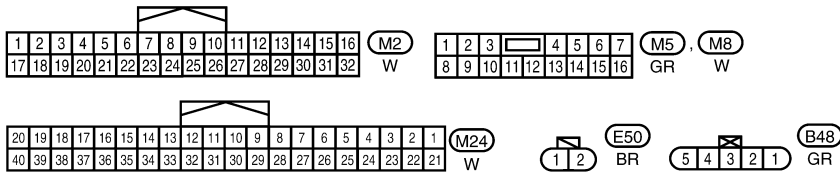
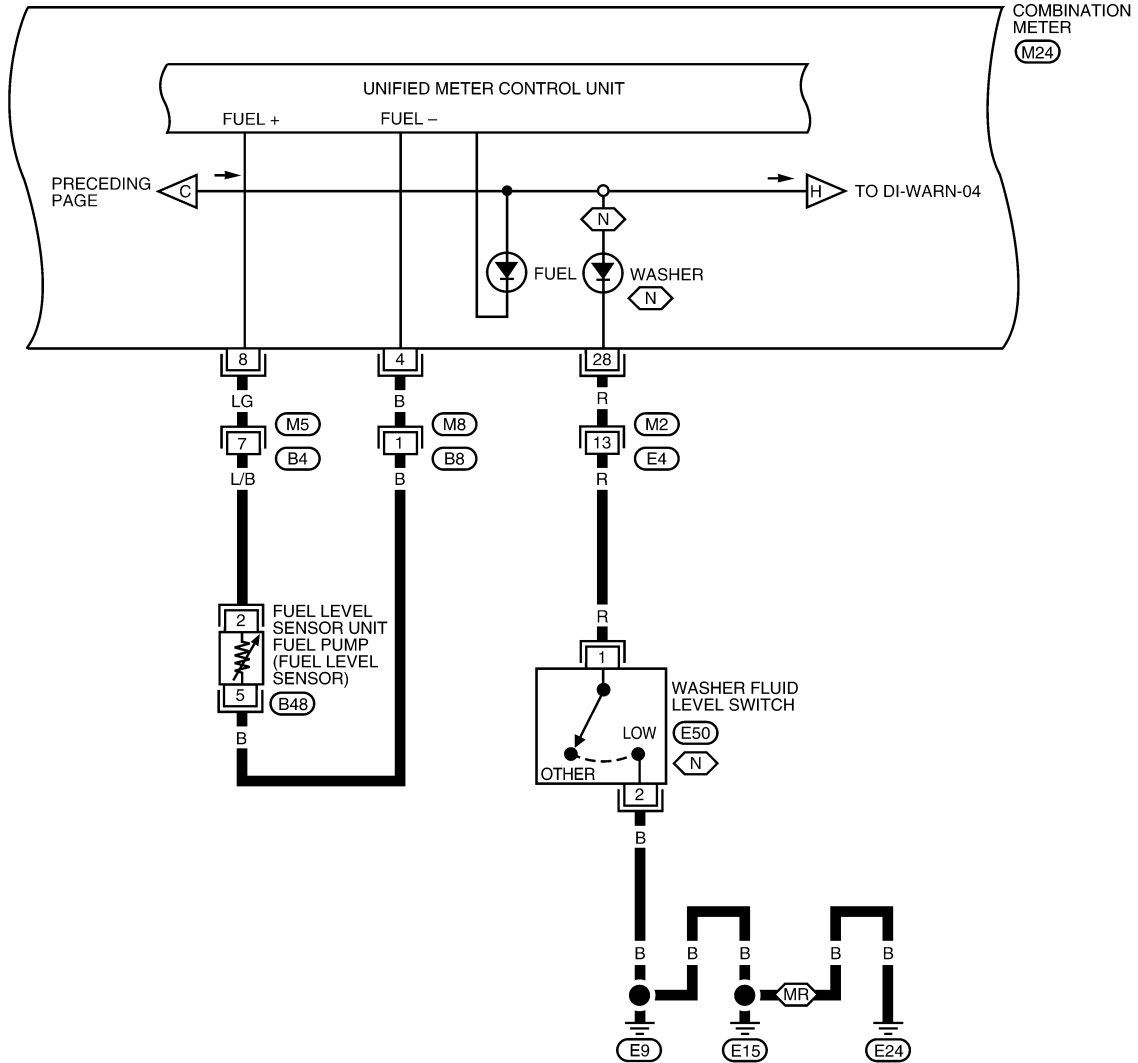

ABNWA0880GB

WARNING LAMPS

< SERVICE INFORMATION >

DI-WARN-03

MR : WITH MR20DE

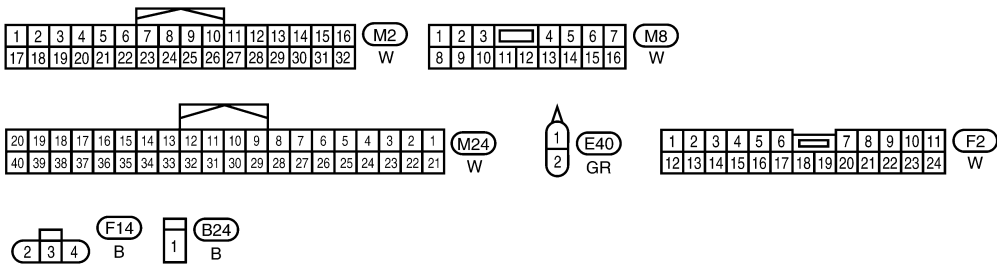
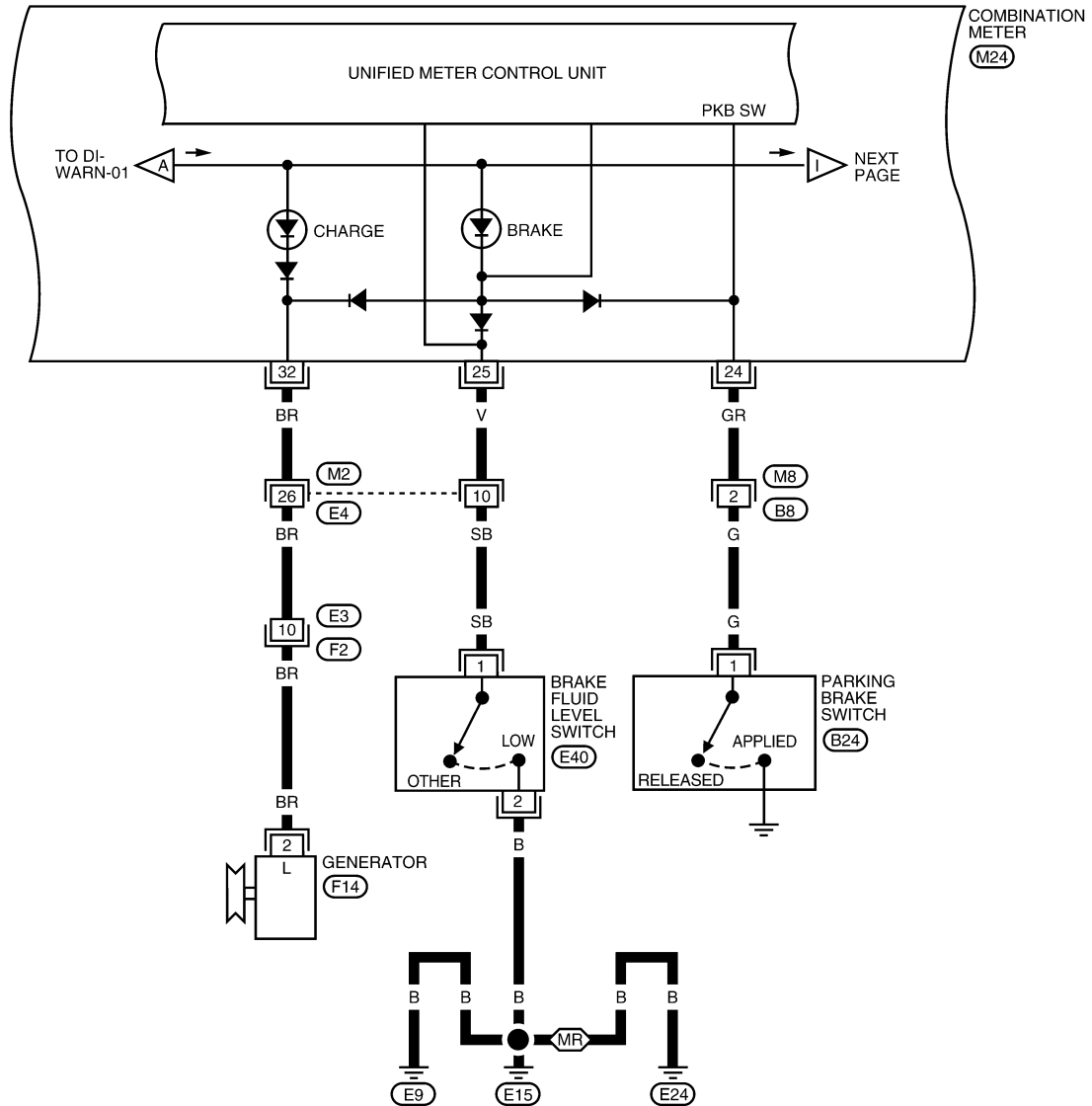

ABNWA0893GB

WARNING LAMPS

< SERVICE INFORMATION >

DI-WARN-04

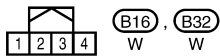
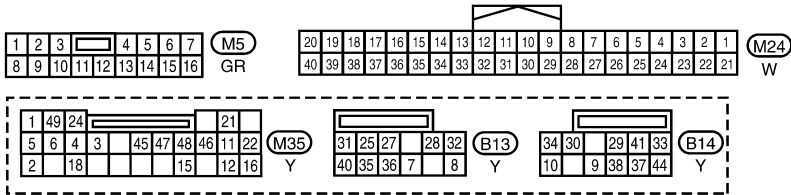
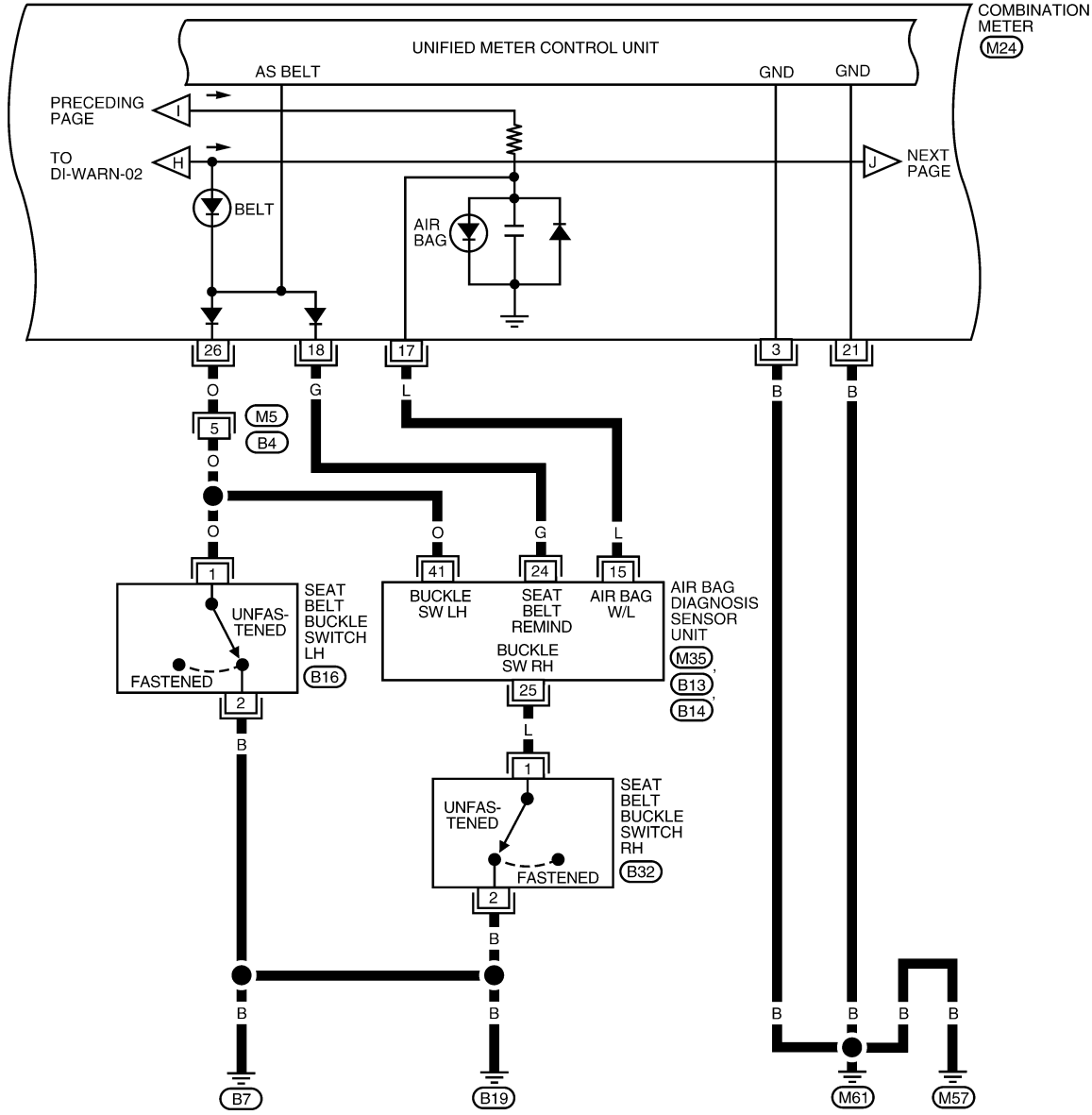

ABNWA0881GB

A
B
C
D
E
F
G
H
I
J
K
L
M
N
O
P

DI

WARNING LAMPS

< SERVICE INFORMATION >

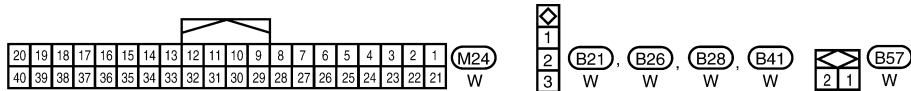
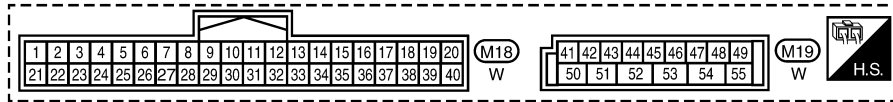
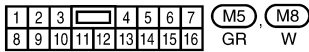
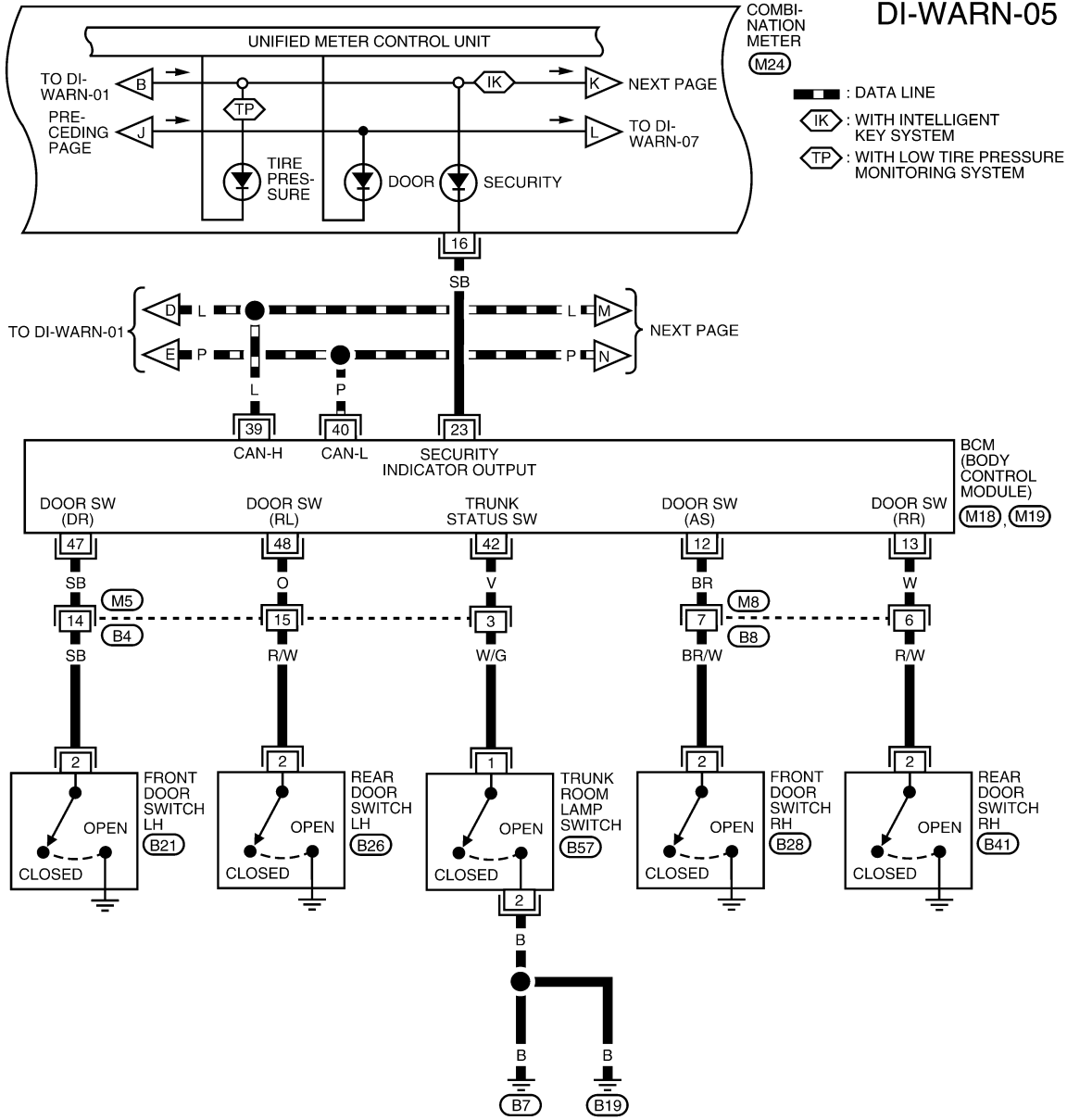

ABNWA0882GB

WARNING LAMPS

< SERVICE INFORMATION >

DI-WARN-06

— : DATA LINE
 (IK) : WITH INTELLIGENT KEY SYSTEM

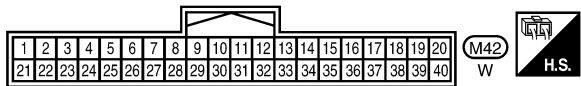
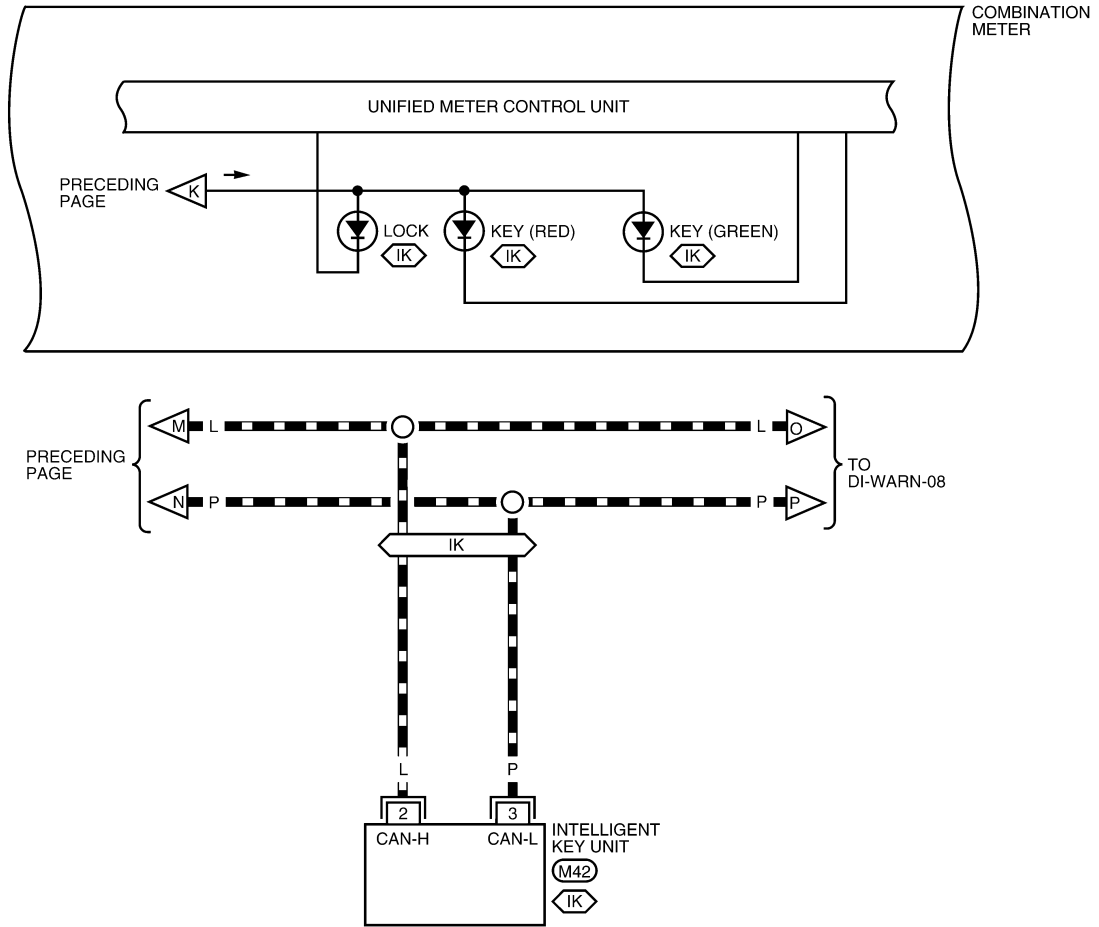

ABNWA0883GB

A
B
C
D
E
F
G
H
I
J
DI
L
M
N
O
P

WARNING LAMPS

< SERVICE INFORMATION >

DI-WARN-07

- : DATA LINE
- ⬡ : WITH INTELLIGENT KEY SYSTEM
- ⬢ : WITHOUT INTELLIGENT KEY SYSTEM
- ⬤ : WITH CVT

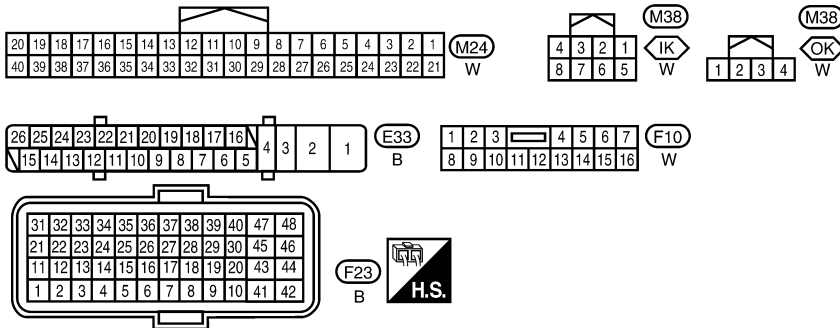
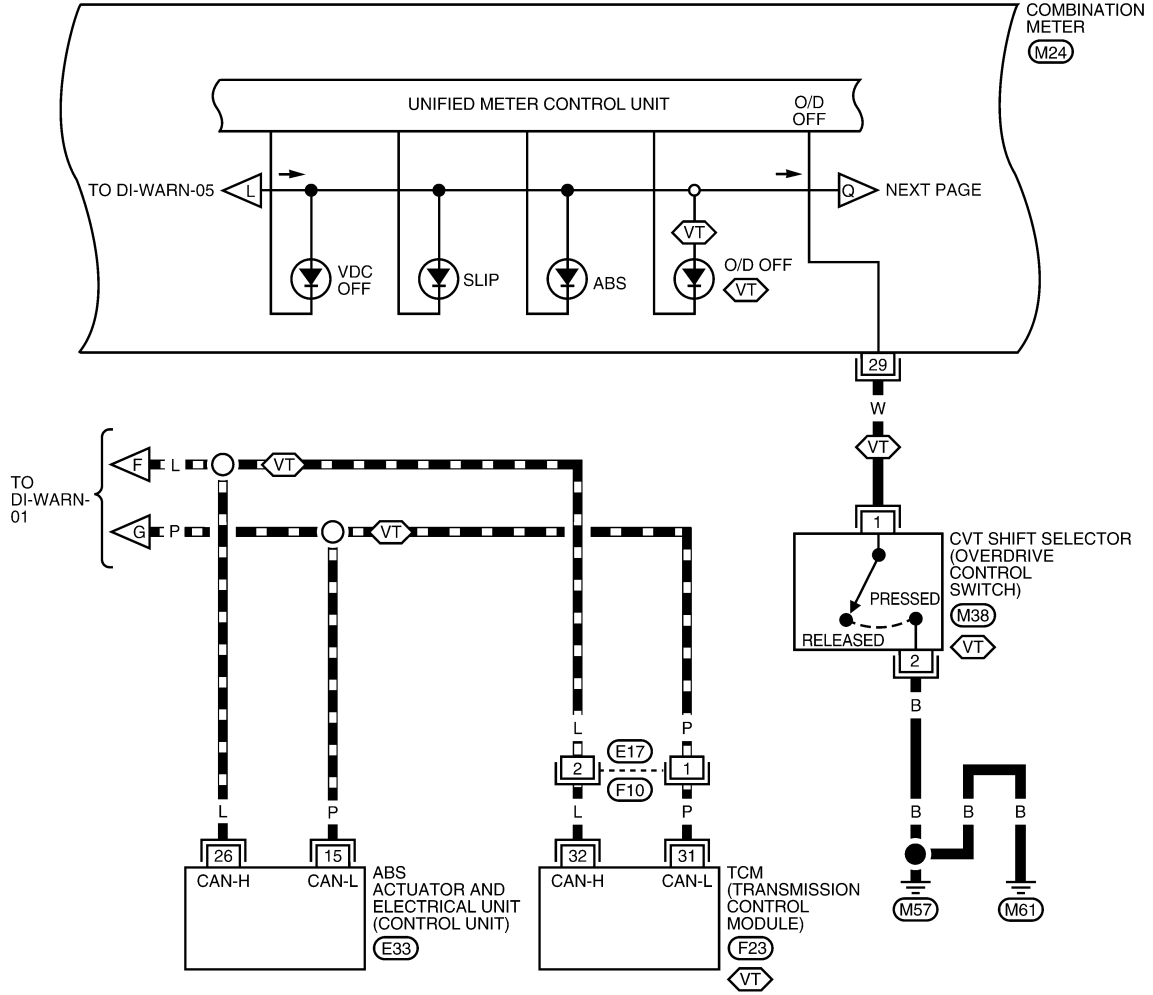

AANWA0460GB

WARNING LAMPS

< SERVICE INFORMATION >

DI-WARN-08

- MR : WITH MR20DE
- QR : WITH QR25DE
- *1 MR : V
- QR : L/B

— : DATA LINE

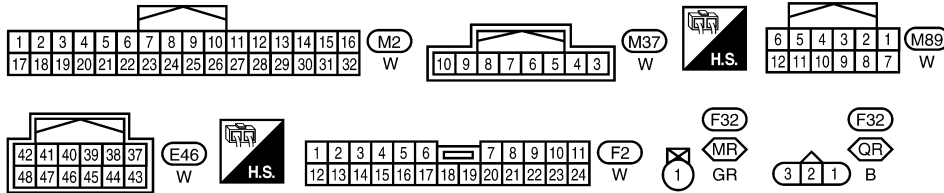
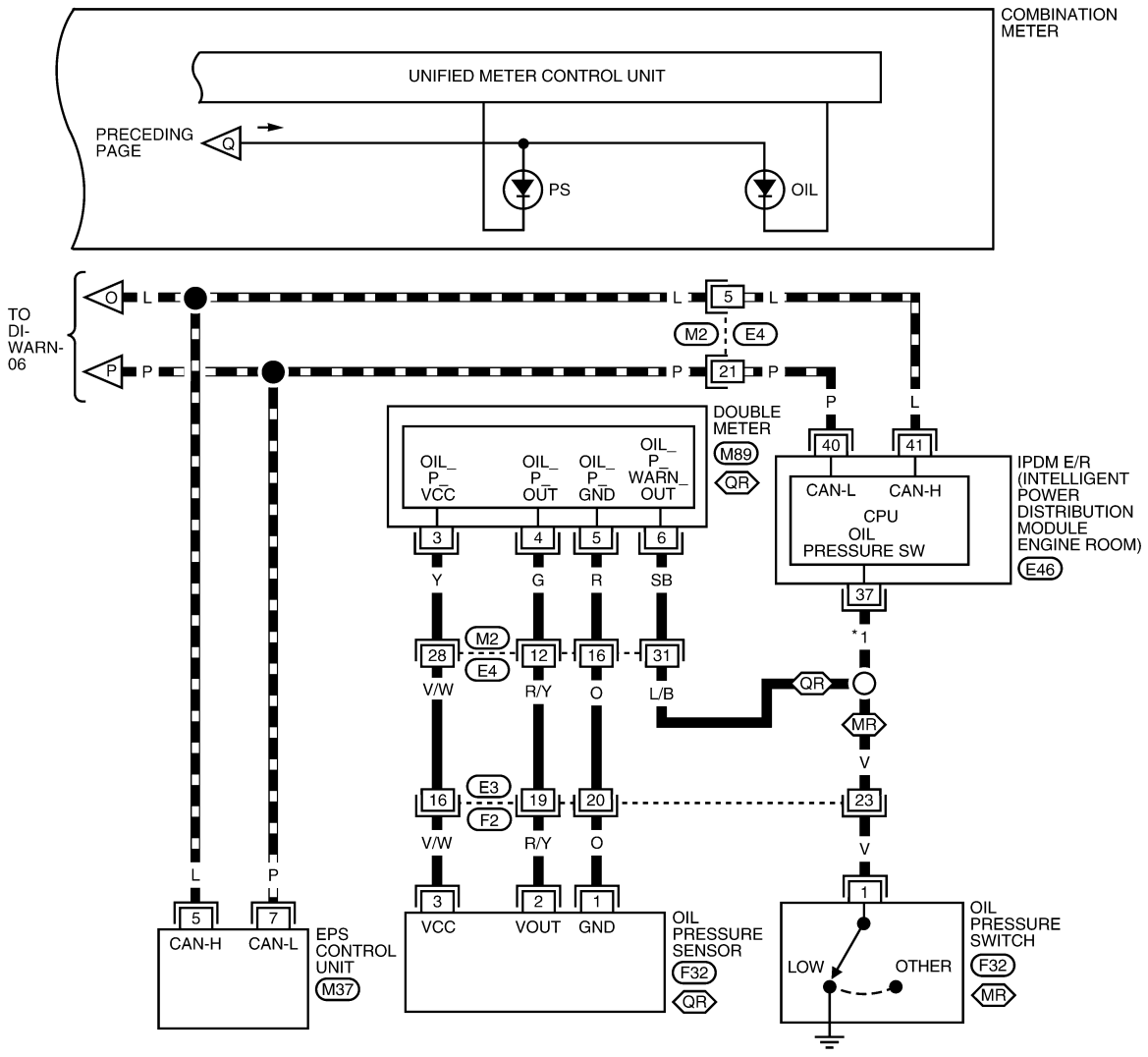

ABNWA0885GB

Oil Pressure Warning Lamp Stays Off (Ignition Switch ON)

INFOID:000000007403099

1. CHECK OIL PRESSURE WARNING LAMP OPERATION

Activate IPDM E/R auto active test. Refer to [PG-21. "Auto Active Test"](#).

Does oil pressure warning lamp blink?

- YES >> GO TO 2.
- NO >> GO TO 5.

WARNING LAMPS

< SERVICE INFORMATION >

2. CHECK IPDM E/R INPUT SIGNAL

1. Turn ignition switch ON.
2. Check voltage between IPDM E/R harness connector and ground.

Terminals		(-)	Condition	Voltage (Approx.)
(+)	Terminal			
IPDM E/R connector				
E46	37	Ground	Engine stopped	0V

OK or NG

OK >> Replace IPDM E/R. Refer to [PG-29, "Removal and Installation of IPDM E/R"](#).

NG >> GO TO 3.

3. CHECK OIL PRESSURE CIRCUIT

1. Disconnect IPDM E/R connector and oil pressure switch connector (with MR20DE) or double meter connector (with QR25DE).
2. Check continuity between IPDM E/R harness connector E46 (A) terminal 37 and oil pressure switch harness connector F32 (B) terminal 1 (with MR20DE) or double meter connector M89 (C) terminal 6 (with QR25DE).

With MR20DE

37 - 1 : Continuity should exist

With QR25DE

37 - 6 : Continuity should exist

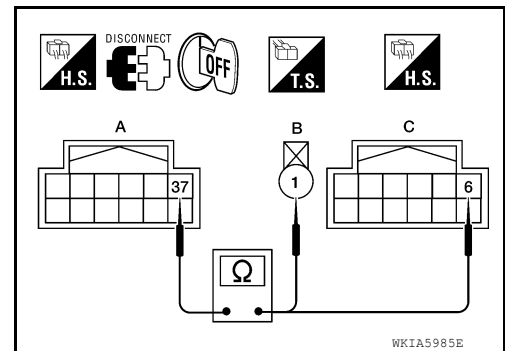
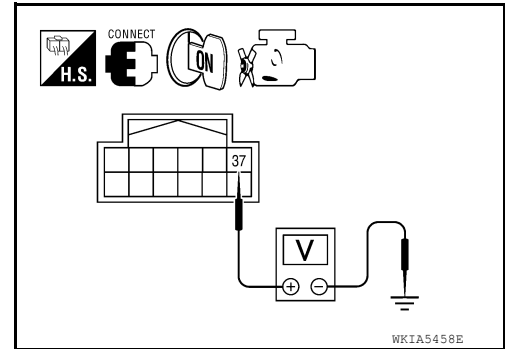

OK or NG

OK >> With MR20DE, GO TO 4. With QR25DE, refer to [DI-31, "Oil Pressure Sensor Inspection"](#).

NG >> Repair harness or connector.

4. CHECK OIL PRESSURE SWITCH

Check oil pressure switch. Refer to [DI-46, "Component Inspection"](#).

OK or NG

OK >> Replace IPDM E/R. Refer to [PG-29, "Removal and Installation of IPDM E/R"](#).

NG >> Replace oil pressure switch.

5. CHECK CAN COMMUNICATION

Select "METER/M&A" on CONSULT, and perform self-diagnosis of combination meter.

Self-diagnostic results content

No malfunction detected>>GO TO 6.

Malfunction detected>> Check applicable parts, and repair or replace as necessary.

6. CHECK COMBINATION METER INPUT SIGNAL

Select "METER/M&A" on CONSULT. Operate ignition switch with "OIL W/L" of "DATA MONITOR" and check operation status.

"OIL W/L"

When ignition switch is in ON position (Engine stopped.) : ON

When engine running : OFF

OK or NG

OK >> Replace combination meter. Refer to [IP-12, "Removal and Installation"](#).

WARNING LAMPS

< SERVICE INFORMATION >

NG >> GO TO 7.

7. CHECK BCM INPUT SIGNAL

Select "BCM" on CONSULT. Then select "SIGNAL BUFFER". Operate ignition switch with "OIL PRESS SW" of "DATA MONITOR" and check operation status.

"OIL PRESS SW"

When ignition switch is in ON : ON
position (Engine stopped.)

When engine running : OFF

OK or NG

OK >> Replace BCM. Refer to [BCS-19, "Removal and Installation of BCM"](#).

NG >> Replace IPDM E/R. Refer to [PG-29, "Removal and Installation of IPDM E/R"](#).

Oil Pressure Warning Lamp Does Not Turn Off (Oil Pressure Is Normal)

INFOID:000000007403100

NOTE:

For oil pressure inspection, refer to [LU-6, "Inspection"](#) (MR20DE) or [LU-18, "Inspection"](#) (QR25DE).

1. CHECK OIL PRESSURE WARNING LAMP OPERATION

Activate IPDM E/R auto active test. Refer to [PG-21, "Auto Active Test"](#).

Does oil pressure warning lamp blink?

YES >> GO TO 2.

NO >> GO TO 5.

2. CHECK IPDM E/R OUTPUT SIGNAL

1. Turn ignition switch OFF.
2. Disconnect oil pressure switch connector (with MR20DE) or double meter connector (with QR25DE).
3. Turn ignition switch ON.
4. Check voltage between oil pressure switch harness connector F32 (A) terminal 1 (with MR20DE) or double meter connector M89 (B) terminal 6 (with QR25DE) and ground.

With MR20DE

1 - ground : Battery voltage

With QR25DE

6 - ground : Battery voltage

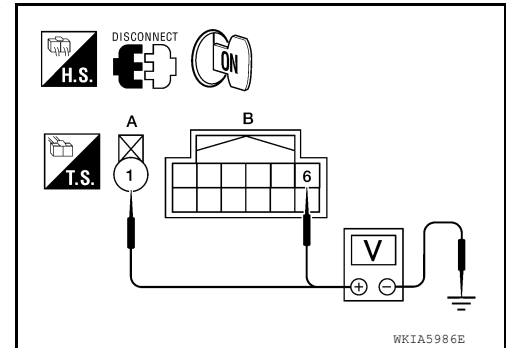

OK or NG

OK >> With MR20DE, GO TO 3. With QR25DE, refer to [DI-31, "Oil Pressure Sensor Inspection"](#).

NG >> GO TO 4.

3. CHECK OIL PRESSURE SWITCH

1. Turn ignition switch OFF.
2. Check oil pressure switch. Refer to [DI-46, "Component Inspection"](#).

OK or NG

OK >> Replace IPDM E/R. Refer to [PG-29, "Removal and Installation of IPDM E/R"](#).

NG >> Replace oil pressure switch.

4. CHECK OIL PRESSURE CIRCUIT

1. Disconnect IPDM E/R connector and oil pressure switch connector (with MR20DE) or double meter connector (with QR25DE).

WARNING LAMPS

< SERVICE INFORMATION >

2. Check continuity between IPDM E/R harness connector E46 (A) terminal 37 and oil pressure switch harness connector F32 (B) terminal 1 (with MR20DE) or double meter connector M89 (C) terminal 6 (with QR25DE).

With MR20DE

37 - 1 : Continuity should exist

With QR25DE

37 - 6 : Continuity should exist

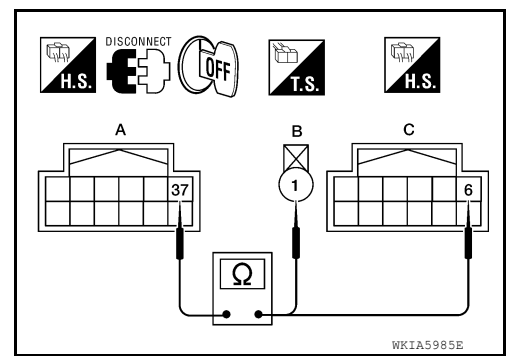

OK or NG

OK >> Check oil pressure circuit for short to ground. If OK then replace IPDM E/R. Refer to [PG-29, "Removal and Installation of IPDM E/R"](#).

NG >> Repair harness or connector.

5. CHECK BCM INPUT SIGNAL

Select "BCM" on CONSULT. Then select "SIGNAL BUFFER". Operate ignition switch with "OIL PRESS SW" of "DATA MONITOR" and check operation status.

"OIL PRESS SW"

When ignition switch is in ON : ON
position (Engine stopped.)

When engine running : OFF

OK or NG

OK >> Replace BCM. Refer to [BCS-19, "Removal and Installation of BCM"](#).

NG >> Replace IPDM E/R. Refer to [PG-29, "Removal and Installation of IPDM E/R"](#).

Component Inspection

INFOID:000000007403101

OIL PRESSURE SWITCH

Check continuity between oil pressure switch and ground.

Condition	Oil pressure [kPa (bar, kg/cm ² , psi)]	Continuity
Engine stopped	Less than 29 (0.3, 0.3, 4)	Yes
Engine running	More than 29 (0.3, 0.3, 4)	No

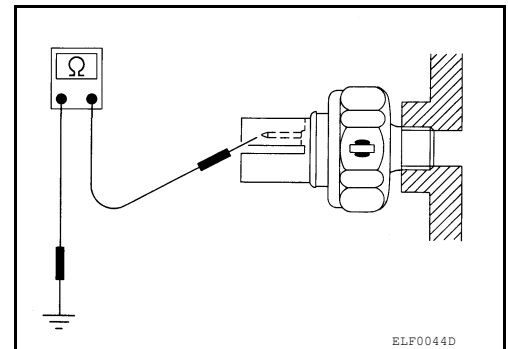

CVT INDICATOR

< SERVICE INFORMATION >

CVT INDICATOR

System Description

INFOID:000000007403102

The TCM receives CVT indicator signals from the transmission range switch. The TCM then sends CVT position indicator signals to the combination meter via CAN communication lines. The combination meter indicates the received shift position.

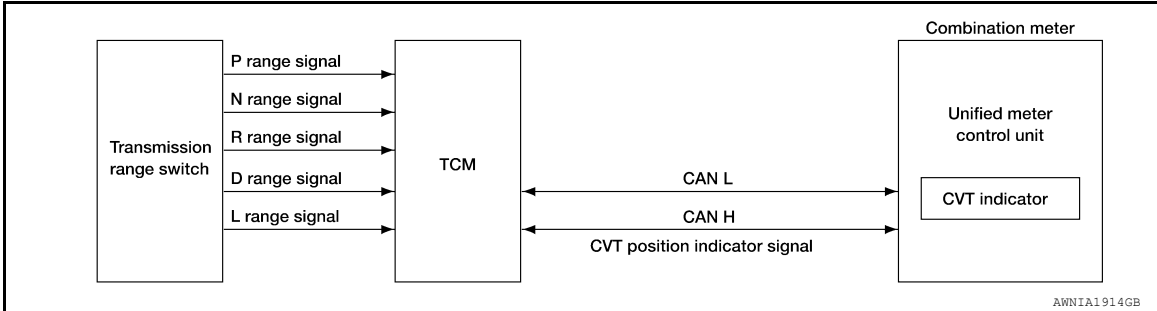

A
B
C
D
E
F
G
H
I
J
DI
L
M
N
O
P

CVT INDICATOR

< SERVICE INFORMATION >

Schematic

INFOID:000000007403103

ⓄR : With QR25DE

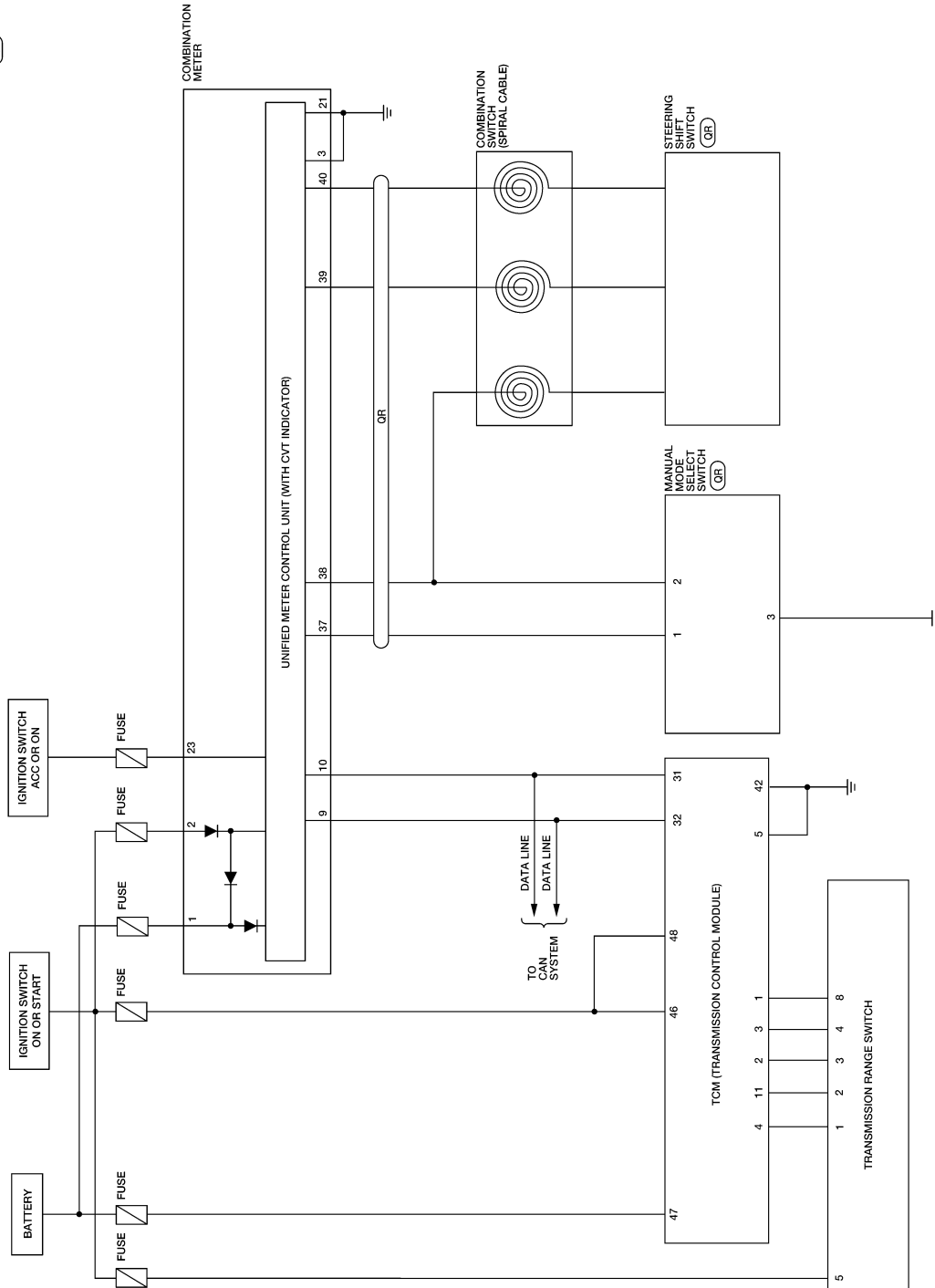

ABNWA0886GB

CVT INDICATOR

< SERVICE INFORMATION >

Wiring Diagram - CVTIND -

INFOID:000000007403104

DI-CVTIND-01

— : DATA LINE

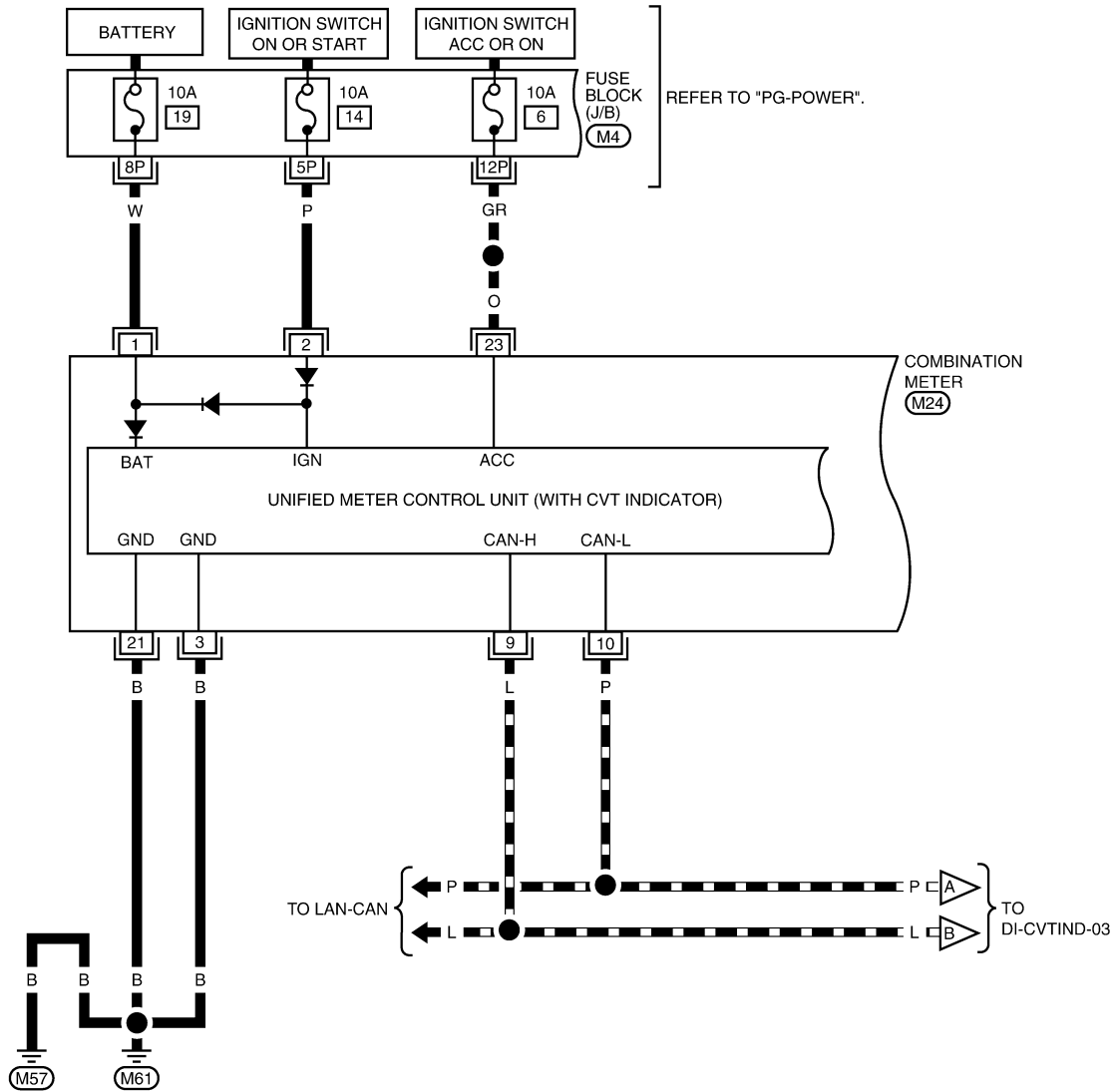

1P	2P	3P	4P	5P	6P	7P	M4		
8P	9P	10P	11P	12P	13P	14P	15P	16P	W

20	19	18	17	16	15	14	13	12	11	10	9	8	7	6	5	4	3	2	1	M24
40	39	38	37	36	35	34	33	32	31	30	29	28	27	26	25	24	23	22	21	W

AANWA0177GB

CVT INDICATOR

< SERVICE INFORMATION >

DI-CVTIND-02

QR : WITH QR25DE

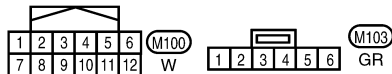
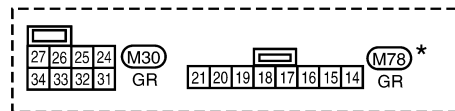
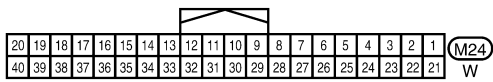
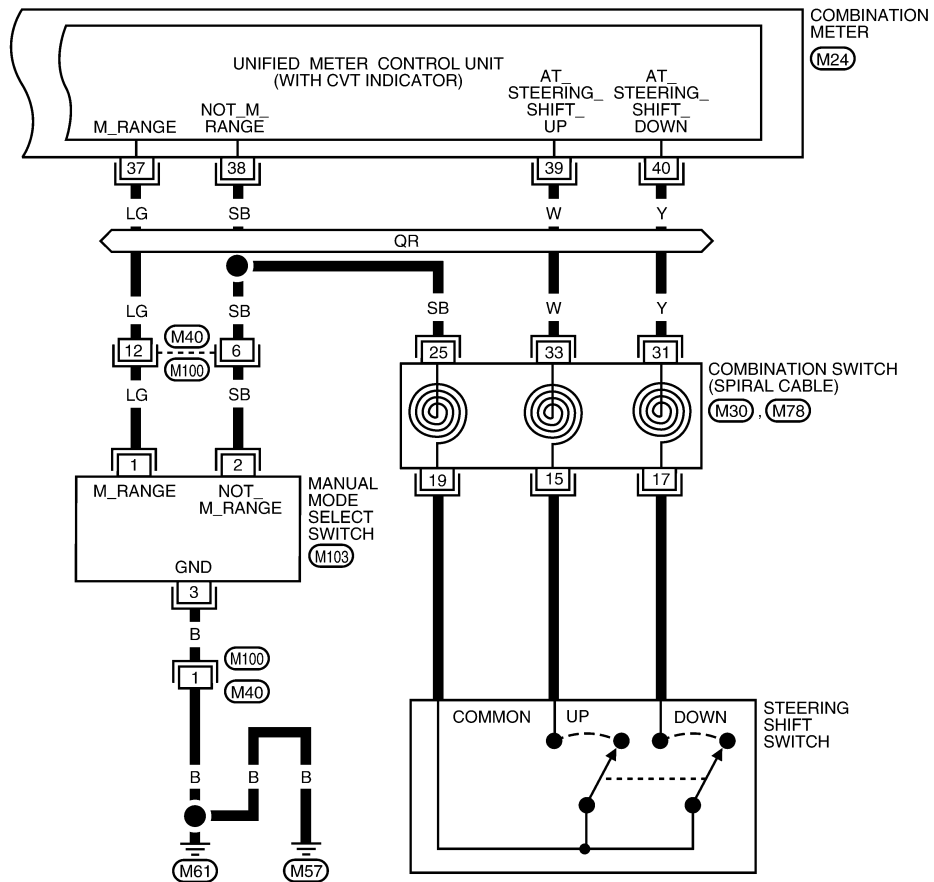

* : THIS CONNECTOR IS NOT SHOWN IN "HARNESS LAYOUT" OF PG SECTION.

ABNWA0887GB

CVT INDICATOR

< SERVICE INFORMATION >

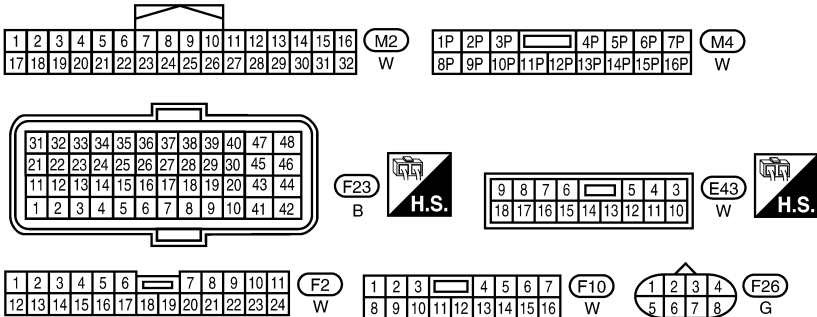
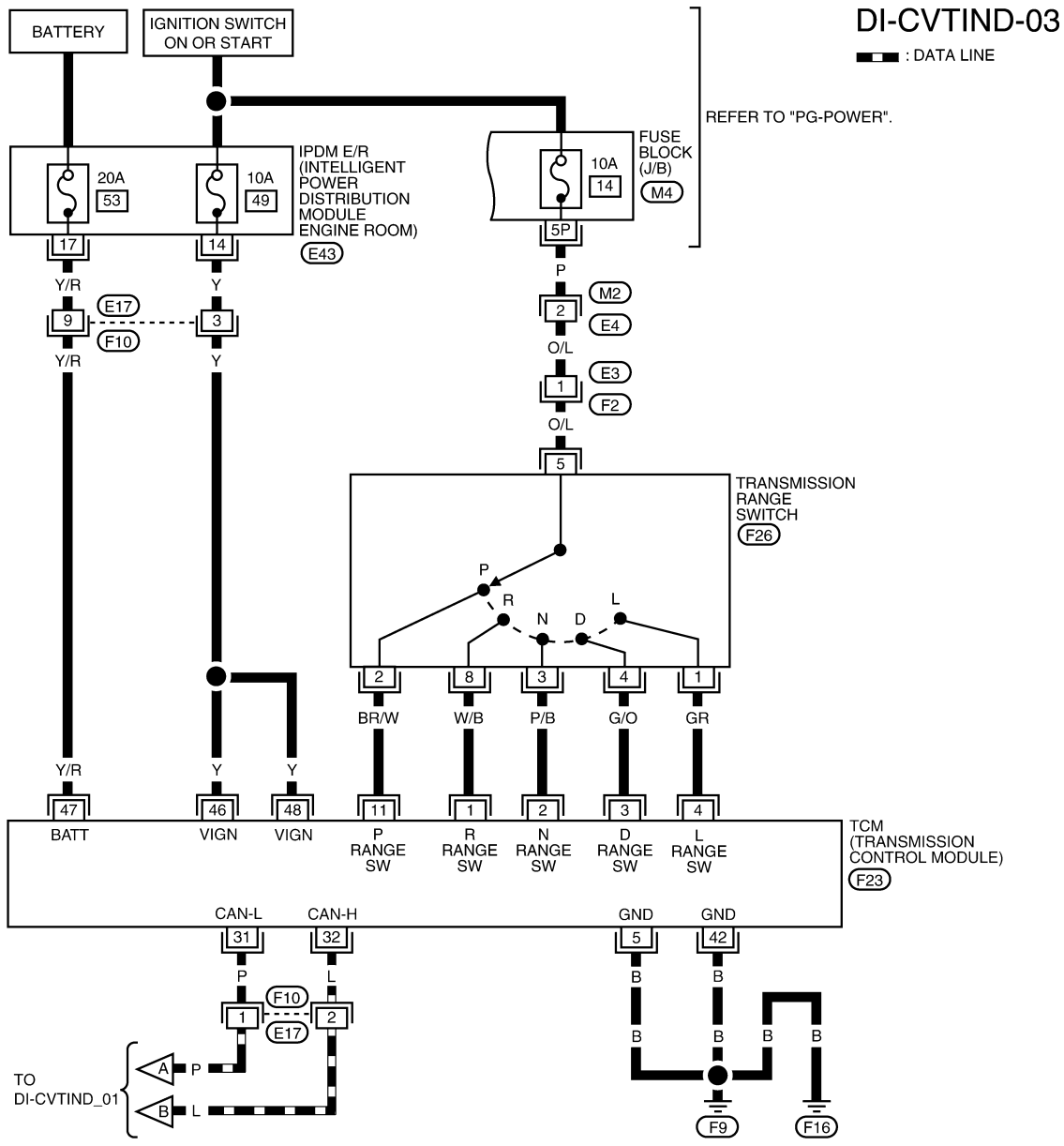

ABNWA0888GB

CVT Indicator Does Not Illuminate

1. CHECK SEGMENT OF CVT INDICATOR

INFOID:000000007403105

CVT INDICATOR

< SERVICE INFORMATION >

Perform self-diagnosis of combination meter. Refer to [DI-14, "Self-Diagnosis Mode of Combination Meter"](#).

Are all segments displayed?

YES >> GO TO 2.

NO >> Replace combination meter. Refer to [IP-12, "Removal and Installation"](#).

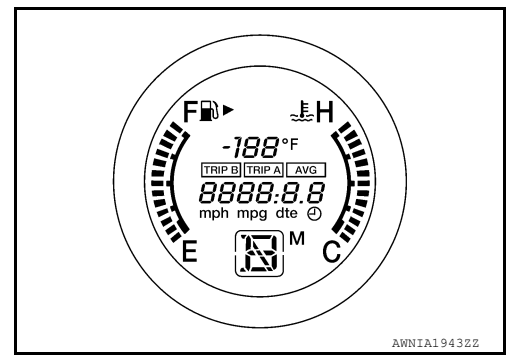

2. CHECK COMBINATION METER (CONSULT)

1. Connect CONSULT.

2. Select "METER/M&A" on CONSULT, and perform self-diagnosis of combination meter. Refer to [DI-15, "CONSULT Function \(METER/M&A\)"](#).

Self-diagnostic results content

No malfunction detected >> GO TO 3.

Malfunction detected >> Check applicable parts, and repair or replace as necessary.

3. CHECK COMBINATION METER INPUT SIGNAL

Use "DATA MONITOR" of "METER/M&A" on CONSULT. Confirm each indication on the monitor while operating the CVT selector lever.

CONSULT display	Switch operation	Operation status
P RANGE IND	P range position	ON
	Except for P range position	OFF
R RANGE IND	R range position	ON
	Except for R range position	OFF
N RANGE IND	N range position	ON
	Except for N range position	OFF
D RANGE IND	D range position	ON
	Except for D range position	OFF
L RANGE IND	L range position	ON
	Except for L range position	OFF

OK or NG

OK >> Replace combination meter. Refer to [IP-12, "Removal and Installation"](#).

NG >> GO TO 4.

4. CHECK SELF-DIAGNOSIS RESULTS OF TCM

Perform self-diagnosis of TCM. Refer to [CVT-47, "CONSULT Function \(TRANSMISSION\)"](#).

OK or NG

OK >> Check TCM input/output signal. Repair or replace malfunctioning part, if necessary. Refer to [CVT-45, "TCM Input/Output Signal Reference Value"](#).

NG >> Check applicable part, and repair or replace as necessary.

WARNING CHIME

< SERVICE INFORMATION >

WARNING CHIME

Component Parts and Harness Connector Location

INFOID:000000007403106

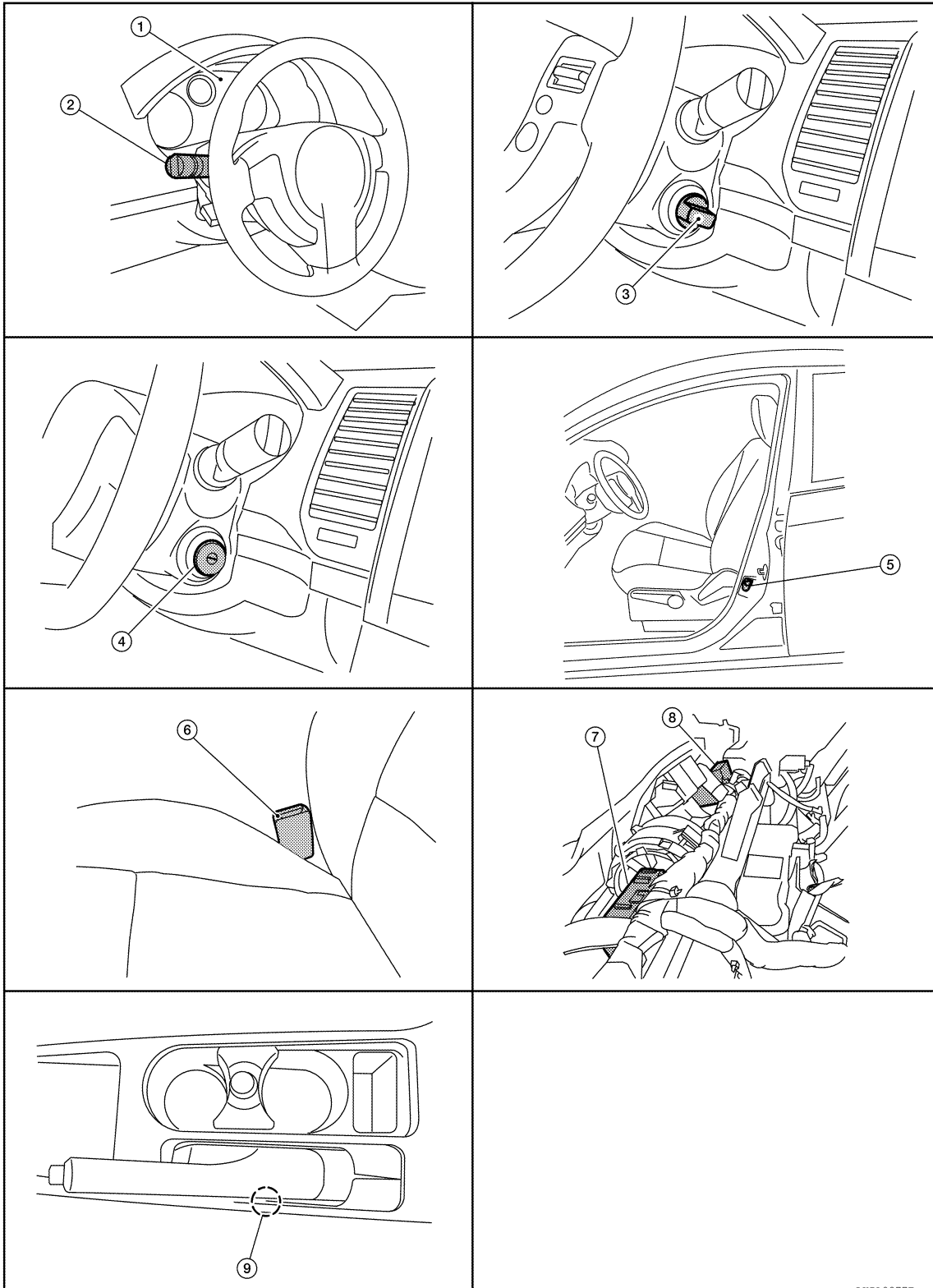

A
B
C
D
E
F
G
H
I
J
DI
L
M
N
O
P

LKIA0877E

WARNING CHIME

< SERVICE INFORMATION >

- | | | |
|---|--|---|
| 1. Combination meter M24 | 2. Combination switch M28 | 3. Key switch and ignition knob switch M49 (with Intelligent Key) |
| 4. Key switch M50 (without Intelligent Key) | 5. Front door switch LH B21 | 6. Seat belt buckle switch LH B16 |
| 7. BCM M18, M19, M20 (view with instrument panel removed) | 8. Intelligent Key unit M42 (view with instrument panel removed) | 9. Parking brake switch B24 |

System Description

INFOID:000000007403107

- Buzzer for warning chime system is installed in the combination meter.
- The buzzer sounds when combination meter receives buzzer output signal with CAN communication line.

POWER SUPPLY AND GROUND CIRCUIT

Power is supplied at all times

- through 50A fusible link (letter j, located in the fuse and fusible link box)
- to BCM terminal 70,
- through 10A fuse [No. 21, located in the fuse block (J/B)]
- to BCM terminal 57,
- through 10A fuse [No. 19, located in the fuse block (J/B)]
- to combination meter terminal 1 and
- to key switch (without Intelligent Key) terminal 2,
- through 10A fuse [No. 9, located in the fuse block (J/B)]
- to key switch and ignition knob switch (with Intelligent Key) terminals 2 and 4.

With ignition switch in the ON or START position, power is supplied

- through 10A fuse [No. 12, located in the fuse block (J/B)]
- to BCM terminal 38,
- through 10A fuse [No. 14, located in the fuse block (J/B)]
- to combination meter terminal 2.

With ignition switch in the ACC or ON position, power is supplied

- through 10A fuse [No. 6, located in the fuse block (J/B)]
- to combination meter terminal 23.

Ground is supplied

- to BCM terminal 67 and
- to combination meter terminals 3 and 21
- through grounds M57 and M61.

IGNITION KEY WARNING CHIME (WITHOUT INTELLIGENT KEY)

With the key inserted into the key switch, and the ignition switch in the OFF or ACC position, when driver's door is opened, the warning chime will sound.

- BCM detects key inserted into the ignition switch, and sends key warning signal to combination meter with CAN communication line.
- When combination meter receives key warning signal, it sounds warning chime.

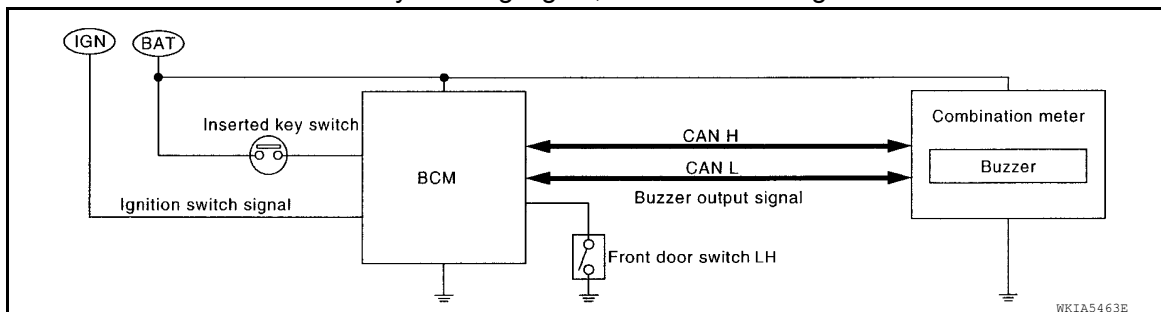

IGNITION KEY WARNING CHIME (WITH INTELLIGENT KEY)

When Mechanical Key Is Used

With the key inserted into the key switch, and the ignition switch in the LOCK or ACC position, when driver's door is opened, the warning chime will sound.

- BCM detects key inserted into the ignition switch, and sends key warning signal to combination meter with CAN communication line.

WARNING CHIME

< SERVICE INFORMATION >

- When combination meter receives key warning signal, it sounds warning chime.

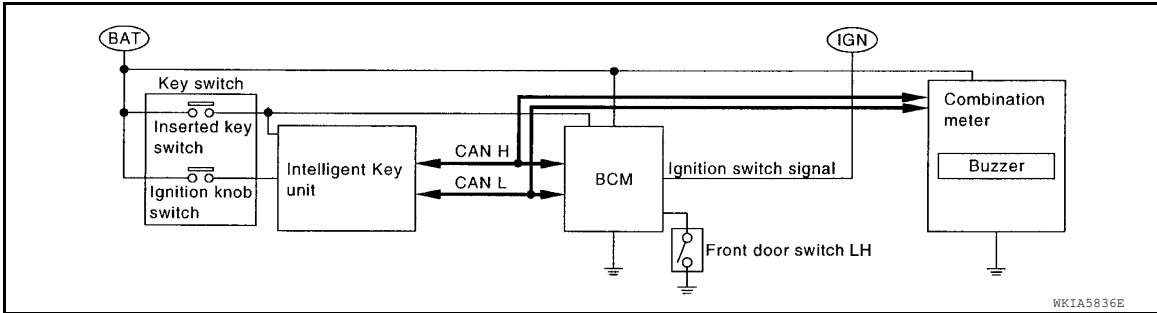

When Intelligent Key Is Carried With The Driver

Refer to [BL-74. "System Description"](#).

LIGHT WARNING CHIME

The warning chime sounds, when driver's door is opened (door switch ON) with lighting switch ON and the ignition switch is in any position other than ON or START.

NOTE:

BCM detected lighting switch in the 1st or 2nd position, refer to [LT-62. "Combination Switch Reading Function"](#).

- BCM detects headlamps are illuminated, and sends light warning signal to combination meter with CAN communication lines.
- When the combination meter receives light warning signal, it sounds warning chime.

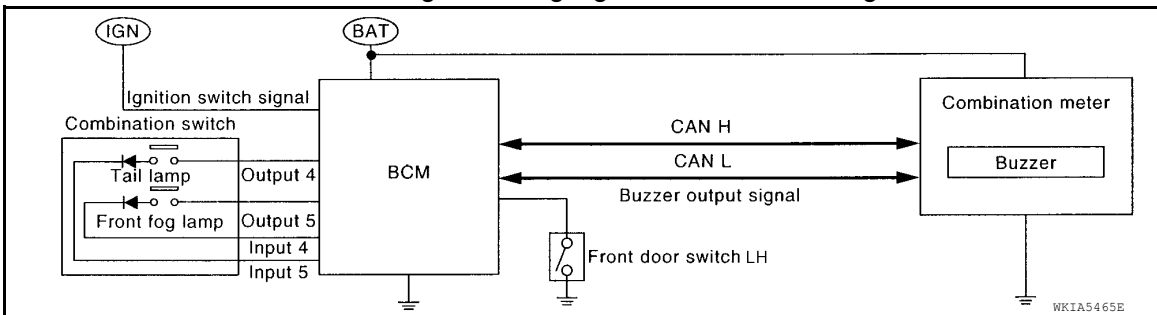

SEAT BELT WARNING CHIME

With the ignition switch turned ON and driver's seat belt unfastened, the seat belt warning chime will sound for approximately 6 seconds.

- The combination meter reads an ON/OFF signal from the seat belt buckle switch LH, and transmits the seat belt buckle switch signal to the BCM with CAN communication.
- The BCM detects the ignition switch turned ON and seat belt buckle switch LH ON. And then, transmits the buzzer output signal (seat belt warning chime) to the combination meter with CAN communication.
- When the combination meter receives the buzzer output signal (seat belt warning chime), it sounds the buzzer.

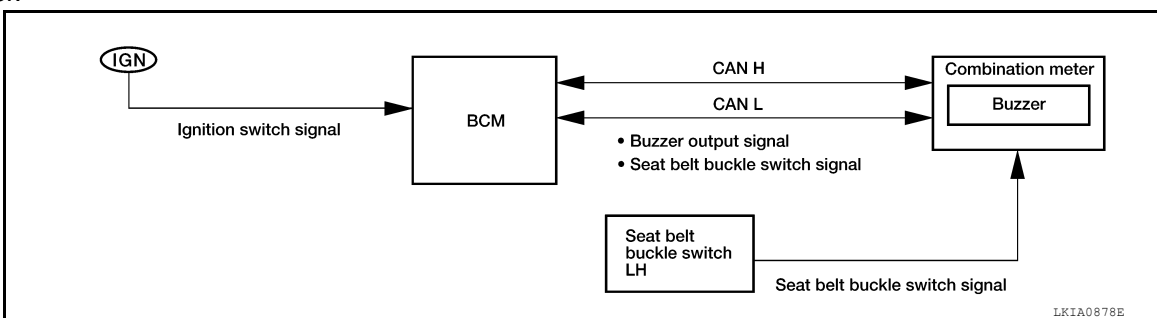

PARKING BRAKE WARNING CHIME

The parking brake warning chime sounds when the parking brake is applied and vehicle speed reaches approximately 2 km/h (1 MPH).

- The combination meter receives a parking brake applied signal from the parking brake switch.

WARNING CHIME

< SERVICE INFORMATION >

- When the combination meter receives a vehicle speed signal from the ABS actuator and electric unit (control unit) it sounds the buzzer.

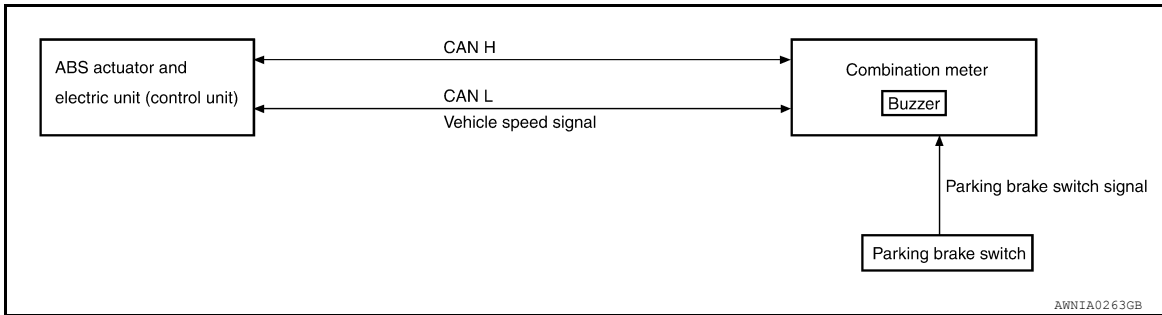

WARNING CHIME

< SERVICE INFORMATION >
Wiring Diagram - CHIME -

INFOID:00000007403108

DI-CHIME-01

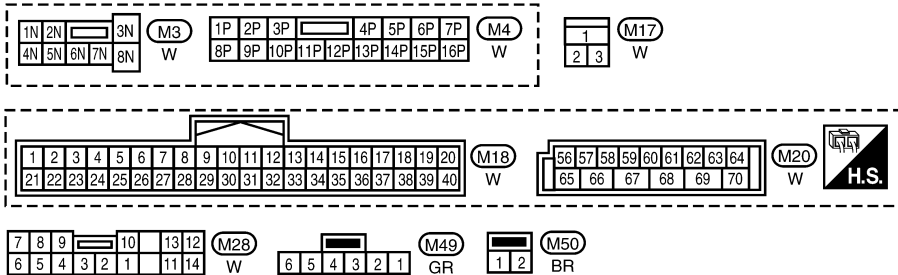
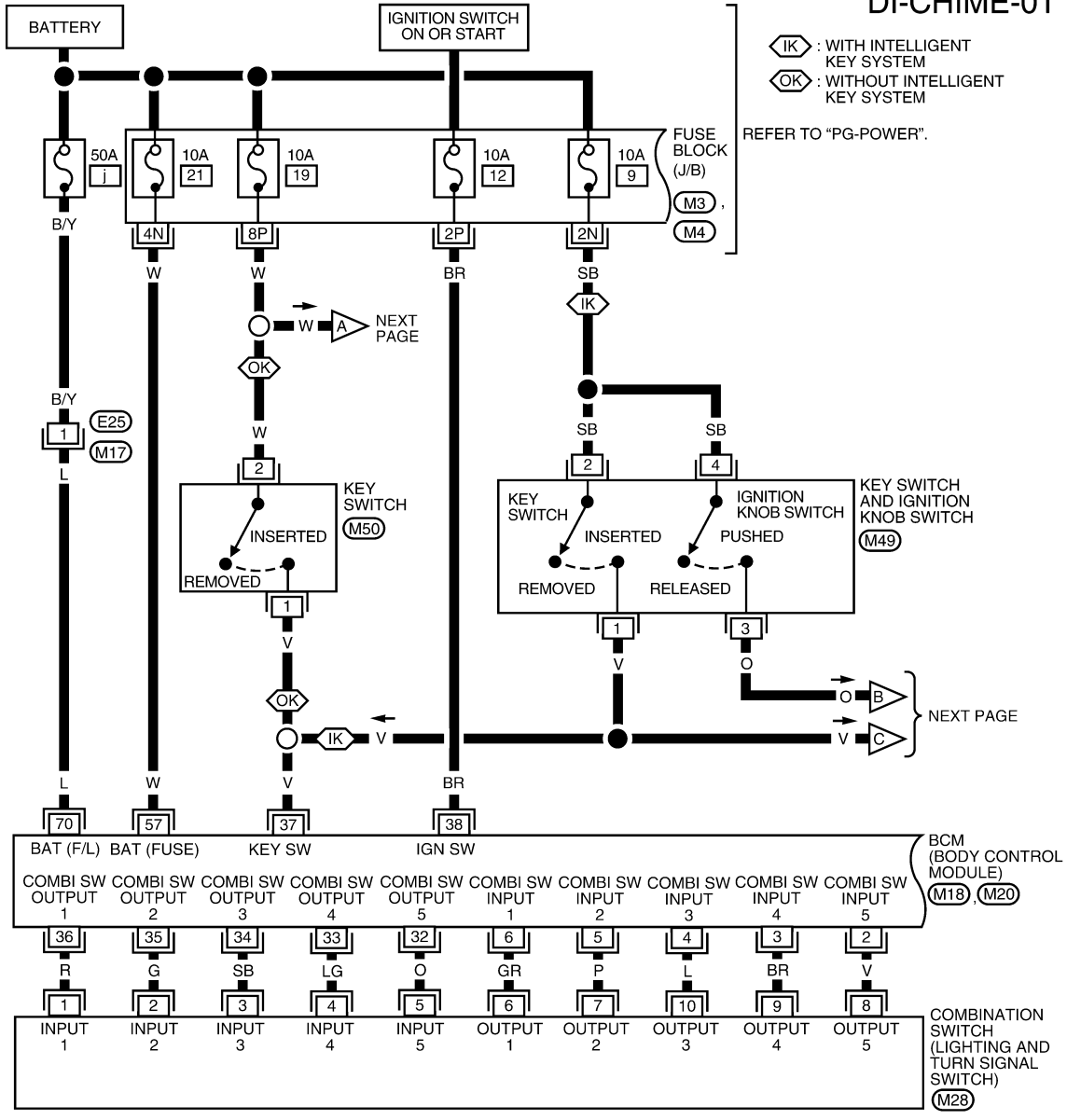

ABNWA0889GB

WARNING CHIME

< SERVICE INFORMATION >

DI-CHIME-02

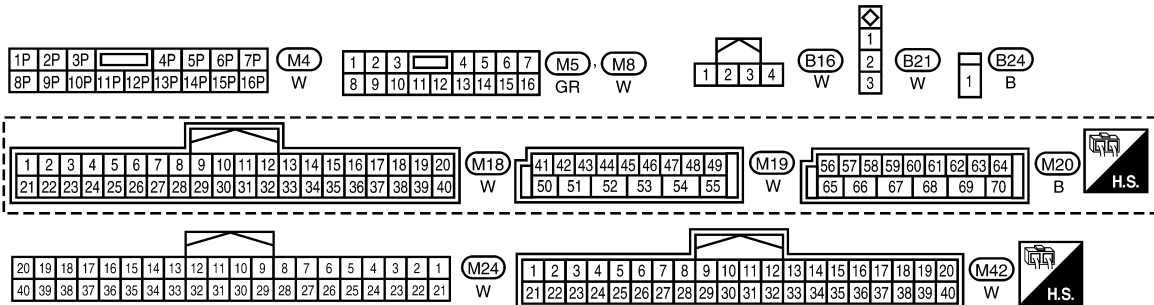
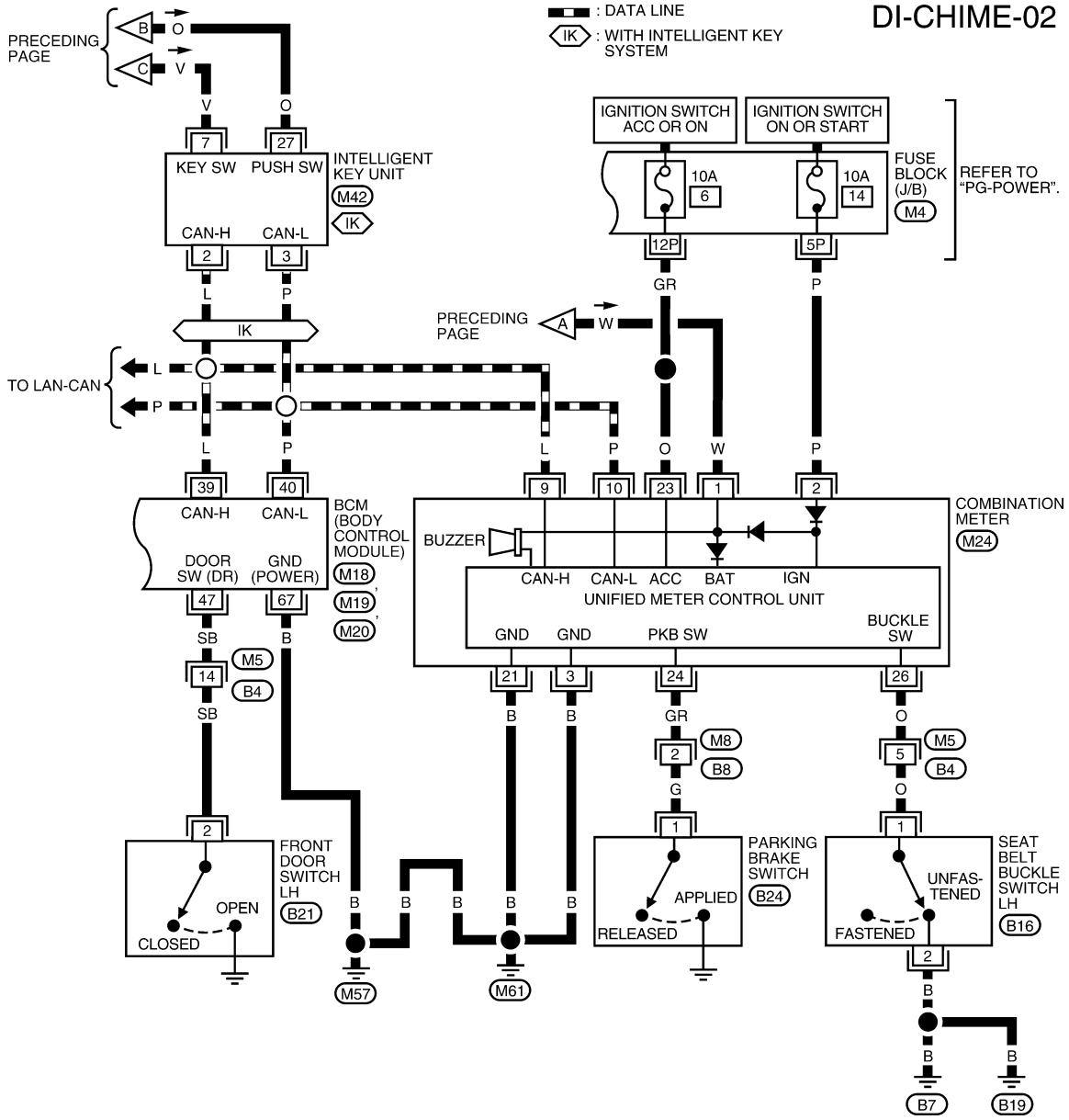

ABNWA0890GB

WARNING CHIME

< SERVICE INFORMATION >

Terminal and Reference Value for BCM

INFOID:000000007605173

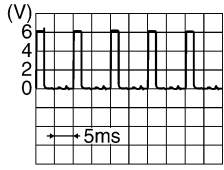
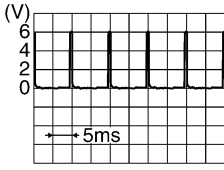
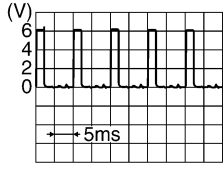
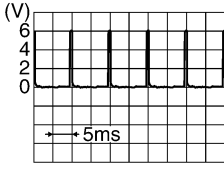
Terminal	Wire color	Signal name	Signal input/output	Measuring condition		Reference value or waveform (Approx.)
				Ignition switch	Operation or condition	
2	V	Combination switch input 5	Input	ON	Lighting, turn, wiper OFF Wiper dial position 4	 <p style="text-align: right; font-size: small;">SKIA5291E</p>
3	BR	Combination switch input 4	Input	ON	Lighting, turn, wiper OFF Wiper dial position 4	 <p style="text-align: right; font-size: small;">SKIA5292E</p>
4	L	Combination switch input 3	Input	ON	Lighting, turn, wiper OFF Wiper dial position 4	 <p style="text-align: right; font-size: small;">SKIA5291E</p>
5	P	Combination switch input 2	Input	ON	Lighting, turn, wiper OFF Wiper dial position 4	 <p style="text-align: right; font-size: small;">SKIA5292E</p>
6	GR	Combination switch input 1				
7	W	Front door key cylinder switch LH (unlock)	Input	OFF	ON (open, 2nd turn)	Momentary 1.5V
					OFF (closed)	0V
8	BR	Front door key cylinder switch LH (lock)	Input	OFF	On (open)	Momentary 1.5V
					OFF (closed)	0V
9	W	Stop lamp switch	Input	OFF	ON (pedal depressed)	0V
					OFF (pedal released)	Battery voltage
10	LG	Rear window defogger switch	Input	ON	Rear window defogger switch ON	0V
					Rear window defogger switch OFF	5V
11	GR	Ignition switch (ACC or ON)	Input	ACC or ON	Ignition switch ACC or ON	Battery voltage
12	BR	Front door switch RH	Input	OFF	ON (open)	0V
					OFF (closed)	Battery voltage
13	W	Rear door switch RH	Input	OFF	ON (open)	0V
					OFF (closed)	Battery voltage

A
B
C
D
E
F
G
H
I
J
K
L
M
N
O
P

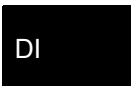

WARNING CHIME

< SERVICE INFORMATION >

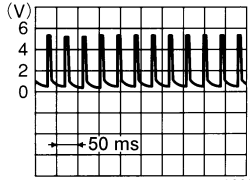
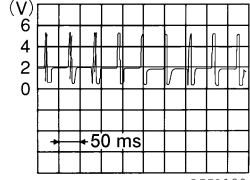
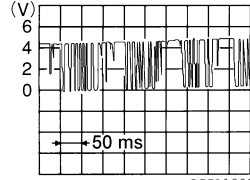
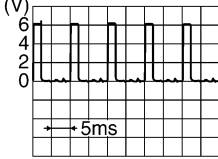
Terminal	Wire color	Signal name	Signal input/output	Measuring condition		Reference value or waveform (Approx.)
				Ignition switch	Operation or condition	
15	L	Tire pressure warning check connector	Input	OFF	—	5V
18	Y	Remote keyless entry receiver (ground)	Output	OFF	—	0V
19	GR	Remote keyless entry receiver (power supply)	Output	OFF	Ignition switch OFF	 <small>LI1A1893E</small>
20	SB	Remote keyless entry receiver signal (signal)	Input	OFF	Stand-by (keyfob buttons released)	 <small>LI1A1894E</small>
					When remote keyless entry receiver receives signal from keyfob (keyfob buttons pressed)	 <small>LI1A1895E</small>
21	R	NATS antenna amp.	Input/Output	OFF → ON	Ignition switch (OFF → ON)	Just after turning ignition switch ON: Pointer of tester should move for approx. 1 second, then return to battery voltage.
23	SB	Security indicator lamp	Output	OFF	Goes OFF → illuminates (Every 2.4 seconds)	Battery voltage → 0V
25	O	NATS antenna amp.	Input/Output	OFF → ON	Ignition switch (OFF → ON)	Just after turning ignition switch ON: Pointer of tester should move for approx. 1 second, then return to battery voltage.
27	G	Compressor ON signal	Input	ON	A/C switch OFF	5V
					A/C switch ON	0V
28	SB	Front blower monitor	Input	ON	Front blower motor OFF	Battery voltage
					Front blower motor ON	0V
29	Y	Hazard switch	Input	OFF	ON	0V
					OFF	5V
32	O	Combination switch output 5	Output	ON	Lighting, turn, wiper OFF Wiper dial position 4	 <small>SK1A5291E</small>

WARNING CHIME

< SERVICE INFORMATION >

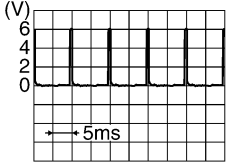
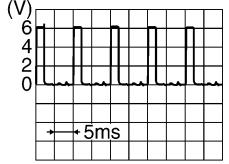
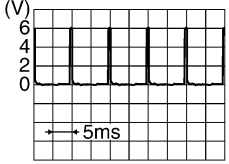
Terminal	Wire color	Signal name	Signal input/output	Measuring condition		Reference value or waveform (Approx.)
				Ignition switch	Operation or condition	
33	LG	Combination switch output 4	Output	ON	Lighting, turn, wiper OFF Wiper dial position 4	 <p style="text-align: right; font-size: small;">SKIA5292E</p>
34	SB	Combination switch output 3	Output	ON	Lighting, turn, wiper OFF Wiper dial position 4	 <p style="text-align: right; font-size: small;">SKIA5291E</p>
35	G	Combination switch output 2	Output	ON	Lighting, turn, wiper OFF Wiper dial position 4	 <p style="text-align: right; font-size: small;">SKIA5292E</p>
36	R	Combination switch output 1				
37 ¹	V	Key switch	Input	OFF	Key inserted	Battery voltage
					Key removed	0V
37 ²	V	Key switch and ignition knob switch	Input	OFF	Key inserted	Battery voltage
					Key removed	0V
38	BR	Ignition switch (ON)	Input	ON	—	Battery voltage
39	L	CAN-H	—	—	—	—
40	P	CAN-L	—	—	—	—
42	V	Trunk room switch	Input	OFF	ON (open)	0V
					OFF (closed)	Battery voltage
45	R	Lock switch	Input	OFF	ON (lock)	0V
					OFF	Battery voltage
46	P	Unlock switch	Input	OFF	ON (unlock)	0V
					OFF	Battery voltage
47	SB	Front door switch LH	Input	OFF	ON (open)	0V
					OFF (closed)	Battery voltage
48	O	Rear door switch LH	Input	OFF	ON (open)	0V
					OFF (closed)	Battery voltage
49	L	Trunk room lamp	Output	OFF	Trunk open (ON)	0V
					Trunk closed (OFF)	Battery voltage
53	R	Trunk lid opener actuator	Output	OFF	Trunk lid (open)	Battery voltage
56	SB	Battery saver output	Output	OFF	15 minutes after ignition switch is turned OFF	0V
				ON	—	Battery voltage
57	W	Battery power supply	Input	OFF	—	Battery voltage

A
B
C
D
E
F
G
H
I
J
DI
L
M
N
O
P

WARNING CHIME

< SERVICE INFORMATION >

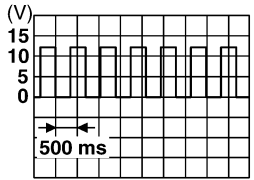
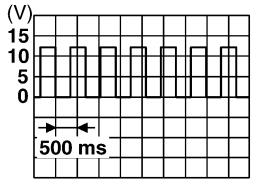
Terminal	Wire color	Signal name	Signal input/output	Measuring condition		Reference value or waveform (Approx.)
				Ignition switch	Operation or condition	
59	G	Front door lock actuator LH (unlock)	Output	OFF	OFF (neutral)	0V
					ON (unlock)	Battery voltage
60	SB	Turn signal (left)	Output	ON	Turn left ON	 <small>SKIA3009J</small>
61	O	Turn signal (right)	Output	ON	Turn right ON	 <small>SKIA3009J</small>
63	R	Interior room lamp	Output	OFF	Any door switch ON (open)	0V
					OFF (closed)	Battery voltage
65	V	All door lock actuators (lock)	Output	OFF	OFF (neutral)	0V
					ON (lock)	Battery voltage
66	G	Front door lock actuator RH, rear door lock actuators LH/RH (unlock)	Output	OFF	OFF (neutral)	0V
					ON (unlock)	Battery voltage
67	B	Ground	Input	ON	—	0V
68	W	Power window power supply (RAP)	Output	—	Ignition switch ON	Battery voltage
					Within 45 seconds after ignition switch OFF	Battery voltage
					More than 45 seconds after ignition switch OFF	0V
					When front door LH or RH is open or power window timer operates	0V
69	P	Battery power supply	Output	OFF	—	Battery voltage
70	L	Battery power supply	Input	OFF	—	Battery voltage

1: Without Intelligent Key

2: With Intelligent Key

CONSULT Function (BCM)

INFOID:000000007605174

CONSULT can display each diagnostic item using the diagnostic test modes shown following.

Diagnostic mode	Content
WORK SUPPORT	Supports inspections and adjustments. Commands are transmitted to the BCM for setting the status suitable for required operation, input/output signals are received from the BCM and received data is displayed.
DATA MONITOR	Displays BCM input/output data in real time.
ACTIVE TEST	Operation of electrical loads can be checked by sending drive signal to them.
SELF DIAGNOSTIC RESULT	Displays BCM self-diagnosis results.

WARNING CHIME

< SERVICE INFORMATION >

Diagnostic mode	Content
CAN DIAG SUPPORT MNTR	The results of transmit/receive diagnosis of CAN communication can be read.
ECU IDENTIFICATION	BCM part number can be read.
CONFIGURATION	Performs BCM configuration read/write functions.

ITEMS OF EACH PART

NOTE:

CONSULT will only display systems the vehicle possesses.

System and item	CONSULT display	Diagnostic test mode (Inspection by part)						
		WORK SUPPORT	SELF-DIAGNOSTIC RESULT	CAN DIAG SUPPORT MNTR	DATA MONITOR	ECU IDENTIFICATION	ACTIVE TEST	CONFIGURATION
BCM	BCM	x	x	x		x		x
Power door lock system	DOOR LOCK	x			x		x	
Rear defogger	REAR DEFOGGER				x		x	
Warning chime	BUZZER				x		x	
Room lamp timer	INT LAMP	x			x		x	
Remote keyless entry system	MULTI REMOTE ENT	x			x		x	
Headlamp	HEAD LAMP	x			x		x	
Wiper	WIPER	x			x		x	
Turn signal lamp Hazard lamp	FLASHER				x		x	
Blower fan switch signal Air conditioner switch signal	AIR CONDITIONER				x			
Intelligent Key	INTELLIGENT KEY				x			
Combination switch	COMB SW				x			
NVIS (NATS)	IMMU				x		x	
Interior lamp battery saver	BATTERY SAVER	x			x		x	
Theft alarm	THEFT ALARM	x			x		x	
Retained accessory power control	RETAINED PWR	x			x		x	
Oil pressure switch	SIGNAL BUFFER				x		x	
Low tire pressure monitor	AIR PRESSURE MONITOR	x	x		x		x	
Trunk lid opener	TRUNK				x		x	
Panic alarm	PANIC ALARM						x	

WORK SUPPORT

Display Item List

Item	Description
RESET SETTING VALUE	Return a value set with WORK SUPPORT of each system to a default value in factory shipment.

WARNING CHIME

< SERVICE INFORMATION >

Trouble Diagnosis

INFOID:000000007403111

HOW TO PERFORM TROUBLE DIAGNOSIS

1. Confirm the symptom and customer complaint.
2. Understand the outline of system. Refer to [DI-54, "System Description"](#).
3. Perform the preliminary inspection. Refer to "PRELIMINARY INSPECTION".
4. According to symptom chart, repair or replace the cause of the malfunction. Refer to "SYMPTOM CHART".
5. Does warning chime system operate normally? If it operates normally, GO TO 6. If not, GO TO 4.
6. Inspection End.

PRELIMINARY INSPECTION

1.CHECK BCM

Perform self-diagnosis of BCM. Refer to [BCS-16, "CONSULT Function \(BCM\)"](#).

Self-diagnostic results content

No malfunction detected>> GO TO 2.

Malfunction detected>> Check applicable parts, and repair or replace corresponding parts.

2.CHECK COMBINATION METER

Perform self-diagnosis of combination meter. Refer to [DI-15, "CONSULT Function \(METER/M&A\)"](#).

Self-diagnostic results content

No malfunction detected>> Inspection End.

Malfunction detected>> Check applicable parts, and repair or replace corresponding parts.

SYMPTOM CHART

Symptom		Diagnoses/Service procedure
All warning chime systems do not activate.		Perform DI-64, "Combination Meter Buzzer Circuit Inspection" . If above check is OK, replace BCM. Refer to BCS-19, "Removal and Installation of BCM" .
Key warning chime does not activate.	Without Intelligent Key.	Perform DI-66, "Key Switch Signal Inspection (Without Intelligent Key)" . If above check is OK, replace BCM. Refer to BCS-19, "Removal and Installation of BCM" .
	With Intelligent Key, when mechanical key is used.	Perform DI-67, "Key Switch and Ignition Knob Switch Signal Inspection (With Intelligent Key, When Mechanical Key Is Used)" . If above check is OK, replace BCM. Refer to BCS-19, "Removal and Installation of BCM" .
	With Intelligent Key, when Intelligent Key is carried with the driver.	Refer to BL-101, "Trouble Diagnosis Symptom Chart" .
Light warning chime does not activate.		Perform DI-69, "Lighting Switch Signal Inspection" . If above check is OK, replace BCM. Refer to BCS-19, "Removal and Installation of BCM" .
Seat belt warning chime does not activate		Perform DI-69, "Lighting Switch Signal Inspection" . If above check is OK, replace BCM. Refer to BCS-19, "Removal and Installation of BCM" .
Parking brake warning chime does not activate		Perform the following inspections <ul style="list-style-type: none">• DI-70, "Parking Brake Switch Signal Inspection"• DI-19, "Vehicle Speed Signal Inspection"

Combination Meter Buzzer Circuit Inspection

INFOID:000000007403112

1.CHECK CHIME OPERATION

1. Select "BUZZER" of "BCM" on CONSULT.
2. Perform "LIGHT WARN ALM" or "IGN KEY WARN ALM" of "ACTIVE TEST".

WARNING CHIME

< SERVICE INFORMATION >

Does chime sound?

- YES >> Combination meter buzzer circuit is OK. Return to [DI-64, "Trouble Diagnosis"](#).
 NO >> GO TO 2.

2. CHECK COMBINATION METER INPUT SIGNAL

- Select "METER/M&A" on CONSULT.
- Turn on hazard switch or lighting switch while monitoring "BUZZER" of "DATA MONITOR" and check operation status.

"BUZZER"

While hazard switch or lighting switch is ON : ON and OFF repeatedly

Except above : OFF

OK or NG

- OK >> Check battery power supply circuit of combination meter. If OK, replace combination meter. Refer to [IP-12, "Removal and Installation"](#).
 NG >> Replace BCM. Refer to [BCS-19, "Removal and Installation of BCM"](#).

Front Door Switch LH Signal Inspection

INFOID:000000007403113

1. CHECK BCM INPUT SIGNAL

With CONSULT

- Select "BCM".
- With "DATA MONITOR" of "BUZZER", confirm "DOOR SW-DR" when the driver's door is operated.

"DOOR SW-DR"

When driver's door is opened : ON

When driver's door is closed : OFF

Without CONSULT

Check voltage between BCM harness connector and ground.

Terminals			Condition	Voltage (Approx.)
(+)		(-)		
BCM connector	Terminal			
M19	47	Ground	Driver's door is opened	0
			Driver's door is closed	Battery voltage

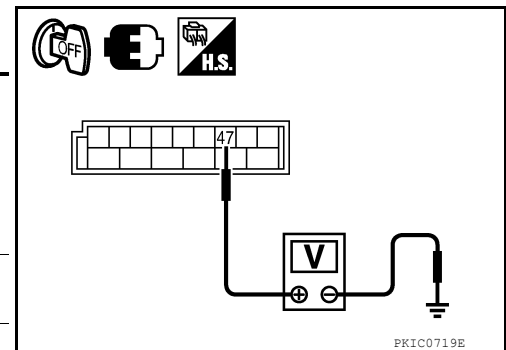

OK or NG

- OK >> Front door switch LH signal is OK. Return to [DI-64, "Trouble Diagnosis"](#).
 NG >> GO TO 2.

2. CHECK FRONT DOOR SWITCH LH CIRCUIT

- Turn ignition switch OFF.
- Disconnect BCM connector and front door switch LH connector.

WARNING CHIME

< SERVICE INFORMATION >

3. Check continuity between BCM harness connector (A) and front door switch LH harness connector (B).

A		B		Continuity
Connector	Terminal	Connector	Terminal	
M19	47	B21	2	Yes

4. Check continuity between BCM harness connector (A) and ground.

A		Ground	Continuity
Connector	Terminal		
M19	47		No

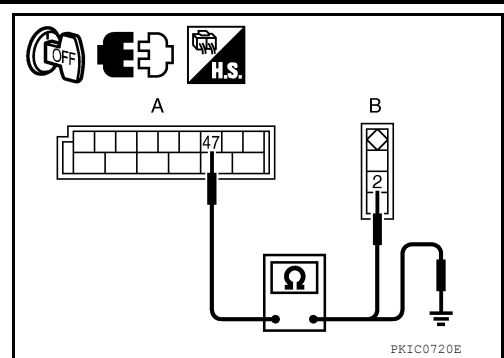

OK or NG

- OK >> GO TO 3.
 NG >> Repair harness or connector.

3. CHECK FRONT DOOR SWITCH LH

Check front door switch LH. Refer to [DI-71, "Electrical Component Inspection"](#).

OK or NG

- OK >> Replace BCM. Refer to [BCS-19, "Removal and Installation of BCM"](#).
 NG >> Replace front door switch LH.

Key Switch Signal Inspection (Without Intelligent Key)

INFOID:000000007403114

1. CHECK FUSE

Check if the key switch 10A fuse [No. 19, located in the fuse block (J/B)] is blown.

OK or NG

- OK >> GO TO 2.
 NG >> Be sure to repair the cause of malfunction before installing new fuse. Refer to [PG-4](#).

2. CHECK BCM INPUT SIGNAL

With CONSULT

- Select "BCM".
- With "DATA MONITOR" of "BUZZER", confirm "KEY ON SW" when the key is operated.

"KEY ON SW"

When key is inserted into ignition key cylinder : ON

When key is removed from ignition key cylinder : OFF

Without CONSULT

Check voltage between BCM harness connector and ground.

Terminals		Condition	Voltage (Approx.)
(+)	(-)		
BCM connector	Terminal		
M18	37	Ground	
		Key is inserted	Battery voltage
		Key is removed	0 V

OK or NG

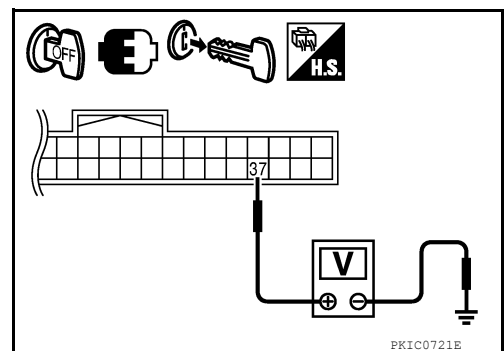

WARNING CHIME

< SERVICE INFORMATION >

- OK >> Key switch signal is OK. Return to [DI-64, "Trouble Diagnosis"](#).
- NG >> GO TO 3.

3.CHECK KEY SWITCH

1. Turn ignition switch OFF.
2. Disconnect key switch connector.
3. Check continuity between key switch terminals 1 and 2.

Terminals		Condition	Continuity
1	2	When key is inserted into ignition key cylinder	Yes
		When key is removed from ignition key cylinder	No

OK or NG

- OK >> GO TO 4.
- NG >> Replace key switch.

4.CHECK KEY SWITCH CIRCUIT

1. Disconnect BCM connector.
2. Check continuity between BCM harness connector (A) and key switch harness connector (B).

A		B		Continuity
Connector	Terminal	Connector	Terminal	
M18	37	M50	1	Yes

3. Check continuity between BCM harness connector (A) and ground.

A		Ground	Continuity
Connector	Terminal		
M18	37		No

OK or NG

- OK >> GO TO 5.
- NG >> Repair harness or connector.

5.CHECK KEY SWITCH POWER SUPPLY CIRCUIT

Check voltage between key switch harness connector and ground.

Terminals			Voltage (Approx.)
(+)		(-)	
Key switch connector	Terminal	Ground	Battery voltage
M50	2		

OK or NG

- OK >> Replace BCM. Refer to [BCS-19, "Removal and Installation of BCM"](#).
- NG >> Repair harness or connector.

Key Switch and Ignition Knob Switch Signal Inspection (With Intelligent Key, When Mechanical Key Is Used)

INFOID:000000007403115

1.CHECK FUSE

Check if the key switch and ignition knob switch 10A fuse [No. 9, located in the fuse block (J/B)] is blown.

OK or NG

- OK >> GO TO 2.
- NG >> Be sure to repair the cause of malfunction before installing new fuse. Refer to [PG-4](#).

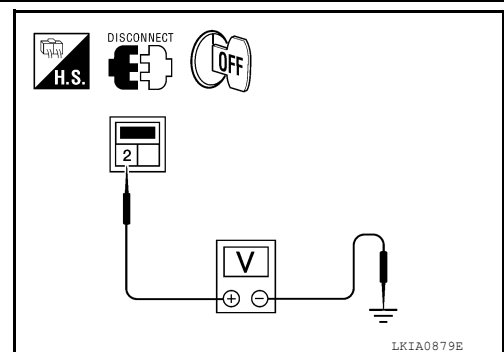
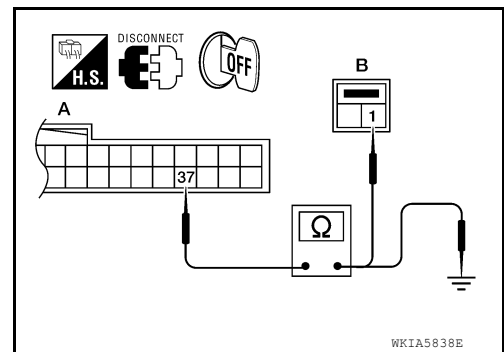
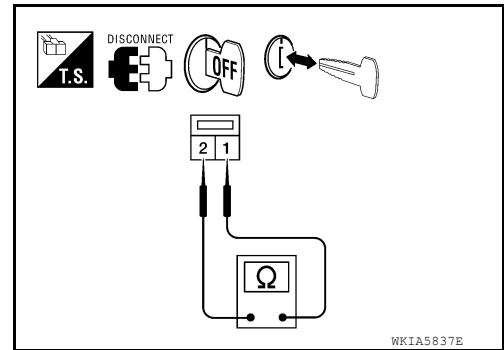

WARNING CHIME

< SERVICE INFORMATION >

2. CHECK BCM INPUT SIGNAL

With CONSULT

1. Select "BCM".
2. With "DATA MONITOR" of "BUZZER", confirm "KEY ON SW" when the key is operated.

"KEY ON SW"

When key is inserted into ignition key cylinder : ON

When key is removed from ignition key cylinder : OFF

Without CONSULT

Check voltage between BCM harness connector and ground.

Terminals		(-)	Condition	Voltage (Approx.)
(+)				
BCM connector	Terminal			
M18	37	Ground	Key is inserted	Battery voltage
			Key is removed	0

OK or NG

- OK >> Key switch and ignition knob switch signal is OK. Return to [DI-64, "Trouble Diagnosis"](#).
- NG >> GO TO 3.

3. CHECK KEY SWITCH

1. Turn ignition switch OFF.
2. Disconnect key switch and ignition knob switch connector.
3. Check continuity between key switch and ignition knob switch terminals 1 and 2.

Terminals		Condition	Continuity
1	2	When key is inserted into ignition key cylinder	Yes
		When key is removed from ignition key cylinder	No

OK or NG

- OK >> GO TO 4.
- NG >> Replace key switch and ignition knob switch.

4. CHECK KEY SWITCH CIRCUIT

1. Disconnect BCM connector.
2. Check continuity between BCM harness connector (A) and key switch and ignition knob switch harness connector (B).

A		B		Continuity
Connector	Terminal	Connector	Terminal	
M18	37	M49	1	Yes

3. Check continuity between BCM harness connector (A) and ground.

A		Ground	Continuity
Connector	Terminal		
M18	37		No

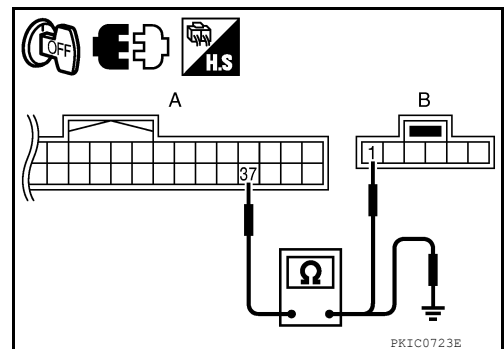
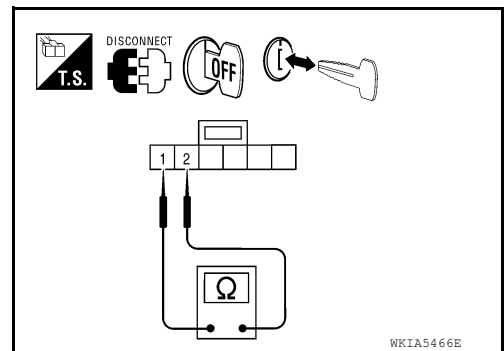
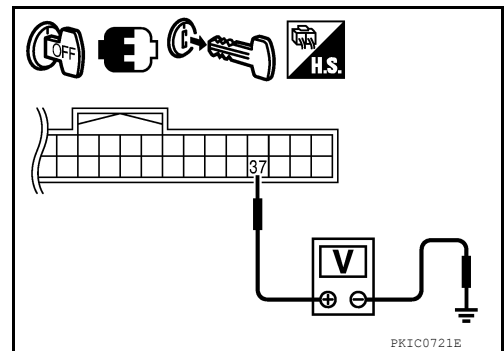

WARNING CHIME

< SERVICE INFORMATION >

OK or NG

- OK >> GO TO 5.
- NG >> Repair harness or connector.

5.CHECK KEY SWITCH POWER SUPPLY CIRCUIT

Check voltage between key switch and ignition knob switch harness connector and ground.

Terminals		Voltage (Approx.)
(+)	(-)	
Key switch and ignition knob switch connector	Terminal	
M49	2	Battery voltage

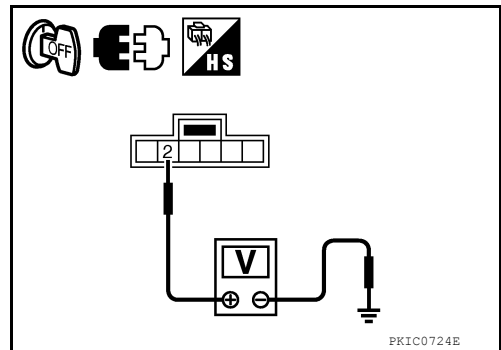

OK or NG

- OK >> Replace BCM. Refer to [BCS-19, "Removal and Installation of BCM"](#).
- NG >> Repair harness or connector.

Lighting Switch Signal Inspection

INFOID:000000007403116

1.CHECK BCM INPUT SIGNAL

1. Select "BCM" on CONSULT.
2. With "DATA MONITOR" of "BUZZER", confirm "LIGHT SW 1ST" when the lighting switch is operated.

"LIGHT SW 1ST"

- Lighting switch (1st position) : ON
- Lighting switch (OFF) : OFF

OK or NG

- OK >> Lighting switch signal is OK. Return to [DI-64, "Trouble Diagnosis"](#).
- NG >> Check the lighting switch. Refer to [LT-63, "Combination Switch Inspection"](#).

Seat Belt Buckle Switch LH Signal Inspection

INFOID:000000007403117

1.CHECK SEAT BELT BUCKLE SWITCH LH SIGNAL INPUT (BCM)

1. Select "BCM" on CONSULT.
2. With "DATA MONITOR" of "BUZZER", confirm "BUCKLE SW" when the seat belt buckle switch LH is operated.

"BUCKLE SW"

- When seat belt is fastened : OFF
- When seat belt is unfastened : ON

OK or NG

- OK >> Inspection End.
- NG >> GO TO 2.

2.CHECK SEAT BELT BUCKLE SWITCH LH SIGNAL INPUT (COMBINATION METER)

1. Turn ignition switch ON.

WARNING CHIME

< SERVICE INFORMATION >

- Check voltage between combination meter harness connector M24 terminal 26 and ground.

Terminals		(-)	Condition	Voltage (Approx.)
(+)				
Combination meter connector	Terminal			
M24	26	Ground	Seat belt fastened	Battery voltage
			Seat belt unfastened	0

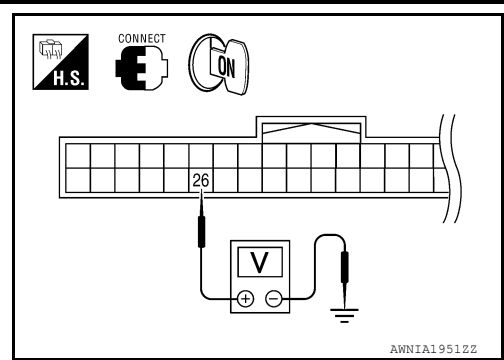

OK or NG

- OK >> Replace combination meter. Refer to [IP-12, "Removal and Installation"](#).
- NG >> GO TO 3.

3.CHECK SEAT BELT BUCKLE SWITCH LH CIRCUIT

- Turn ignition switch OFF.
- Disconnect combination meter connector and seat belt buckle switch LH connector.
- Check continuity between combination meter harness connector (A) and seat belt buckle switch LH harness connector (B).

A		B		Continuity
Connector	Terminal	Connector	Terminal	
M24	26	B16	1	Yes

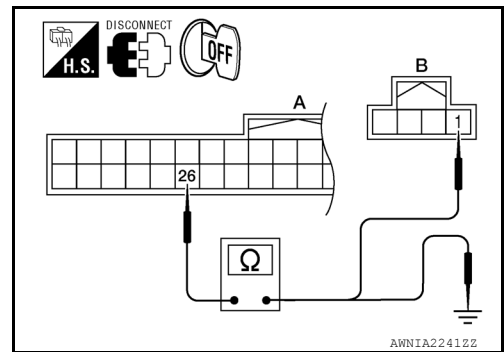

- Check continuity between combination meter harness connector (A) and ground.

A		Ground	Continuity
Connector	Terminal		
M24	26		No

OK or NG

- OK >> GO TO 4.
- NG >> Repair harness or connector.

4.CHECK SEAT BELT BUCKLE SWITCH LH

Check seat belt buckle switch LH. Refer to [DI-71, "Electrical Component Inspection"](#).

OK or NG

- OK >> Check seat belt buckle switch LH ground circuit.
- NG >> Replace seat belt buckle switch LH.

Parking Brake Switch Signal Inspection

INFOID:000000007403118

1.CHECK PARKING BRAKE SWITCH SIGNAL INPUT (COMBINATION METER)

- Turn ignition switch ON.
- Check voltage between combination meter harness connector M24 terminal 24 and ground.

Terminals		(-)	Condition	Voltage (Approx.)
(+)				
Combination meter connector	Terminal			
M24	24	Ground	Parking brake released	Battery voltage
			Parking brake applied	0

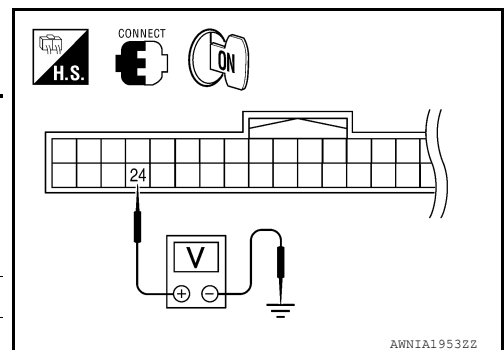

OK or NG

WARNING CHIME

< SERVICE INFORMATION >

- OK >> Replace combination meter. Refer to [IP-12, "Removal and Installation"](#).
- NG >> GO TO 2.

2. CHECK PARKING BRAKE SWITCH CIRCUIT

1. Turn ignition switch OFF.
2. Disconnect combination meter connector and parking brake switch connector.
3. Check continuity between combination meter harness connector (A) and parking brake switch harness connector (B).

A		B		Continuity
Connector	Terminal	Connector	Terminal	
M24	24	B24	1	Yes

4. Check continuity between combination meter harness connector (A) and ground.

A		Ground	Continuity
Connector	Terminal		
M24	24		No

OK or NG

- OK >> GO TO 3.
- NG >> Repair harness or connector.

3. CHECK PARKING BRAKE SWITCH

Check parking brake switch. Refer to [DI-71, "Electrical Component Inspection"](#).

OK or NG

- OK >> Check parking brake switch case ground.
- NG >> Replace parking brake switch.

Electrical Component Inspection

INFOID:000000007403119

FRONT DOOR SWITCH LH

Check continuity between terminal 2 and door switch case ground.

Terminal	Condition	Continuity
2	Door switch case ground	When door switch is released. Yes
		When door switch is pushed. No

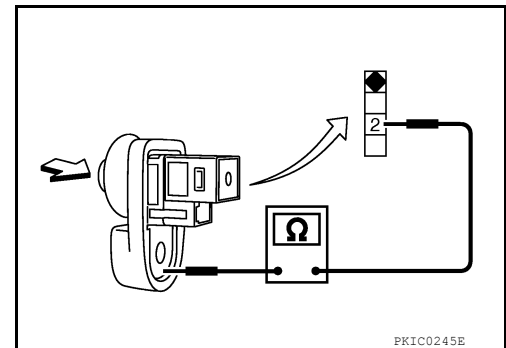

SEAT BELT BUCKLE SWITCH LH

Check continuity between terminals 1 and 2.

Terminal	Condition	Continuity
1	2	When seat belt LH is fastened. No
		When seat belt LH is unfastened. Yes

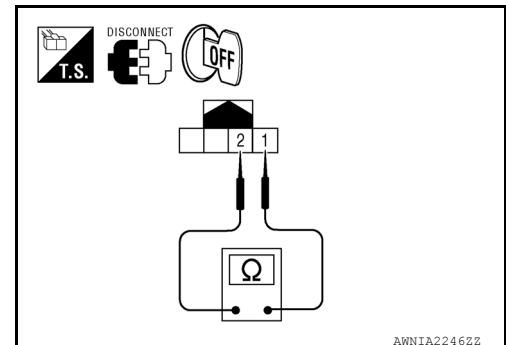

PARKING BRAKE SWITCH

A
B
C
D
E
F
G
H
I
J
K
L
M
N
O
P

WARNING CHIME

< SERVICE INFORMATION >

Check continuity between terminal 1 and parking brake switch case ground.

Terminal		Condition	Continuity
1	Parking brake switch case ground	When parking brake is applied.	Yes
		When parking brake is released.	No

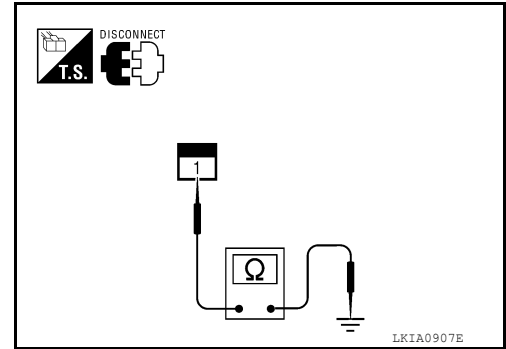

BOARD COMPUTER

< SERVICE INFORMATION >

BOARD COMPUTER

System Description

INFOID:000000007403120

FUNCTION

The board computer can indicate the following items.

- Outside air temperature
- Distance to empty (DTE)
- Trip distance
- Trip time
- Instant fuel consumption
- Average fuel consumption
- Average vehicle speed

OUTSIDE AIR TEMPERATURE INDICATION

The outside air temperature indication is displayed while the ignition switch is in the ON position.

Signal is supplied

- through ambient sensor terminal 2
- to combination meter (board computer) terminal 35.

Indication range is between -22 and 140°F (-30 and 60°C). The indicated temperature is not affected by engine heat. It changes only when one of the following conditions exists.

- When vehicle speed is more than 20 km/h (12 MPH).
- The ignition switch has been turned OFF for more than 3.5 hours.
- When outside air temperature is less than the indicated temperature.

DISTANCE TO EMPTY (DTE) INDICATION

The DTE indication provides the driver with an estimation of the distance that can be driven before refueling. The DTE is calculated by signals from the fuel level sensor unit (fuel remaining), ECM (fuel consumption) and the ABS actuator and electric unit (vehicle speed). When the battery is disconnected and reconnected, DTE mode will display "---" until the vehicle is driven 0.3 miles (0.5 km).

TRIP DISTANCE

Trip distance is calculated by signal from the ABS actuator and electric unit (vehicle speed). If trip distance is reset, trip time will be reset at the same time.

TRIP TIME

Trip time displays cumulative ignition switch ON time. If trip time is reset, trip distance will be reset at the same time.

INSTANT FUEL CONSUMPTION

Instant fuel consumption indication is calculated by signals from the ABS actuator and electric unit (vehicle speed) and the ECM (fuel consumption). The indication updates instantly while driving.

AVERAGE FUEL CONSUMPTION

Average fuel consumption indication is calculated by signals from the ABS actuator and electric unit (vehicle speed) and the ECM (fuel consumption).

AVERAGE VEHICLE SPEED

Average vehicle speed indication is calculated by running distance and running time. If average vehicle speed is reset, average fuel consumption will be reset at the same time. After resetting, the display will show "---" for 30 seconds.

HOW TO CHANGE/RESET INDICATION

Indication can be changed in the following order by momentarily depressing the board computer button.

Odometer → TRIP A → TRIP B → DTE → Instant fuel consumption → Average vehicle speed → Average fuel consumption → Trip time→.

Holding the switch for more than a second will reset the indication of the currently displayed mode.

CAN Communication System Description

INFOID:000000007403121

Refer to [LAN-7, "System Description"](#).

BOARD COMPUTER

< SERVICE INFORMATION >

Wiring Diagram - B/COMP -

INFOID:000000007403122

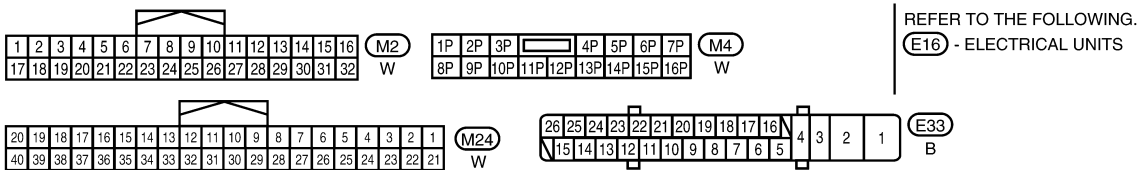
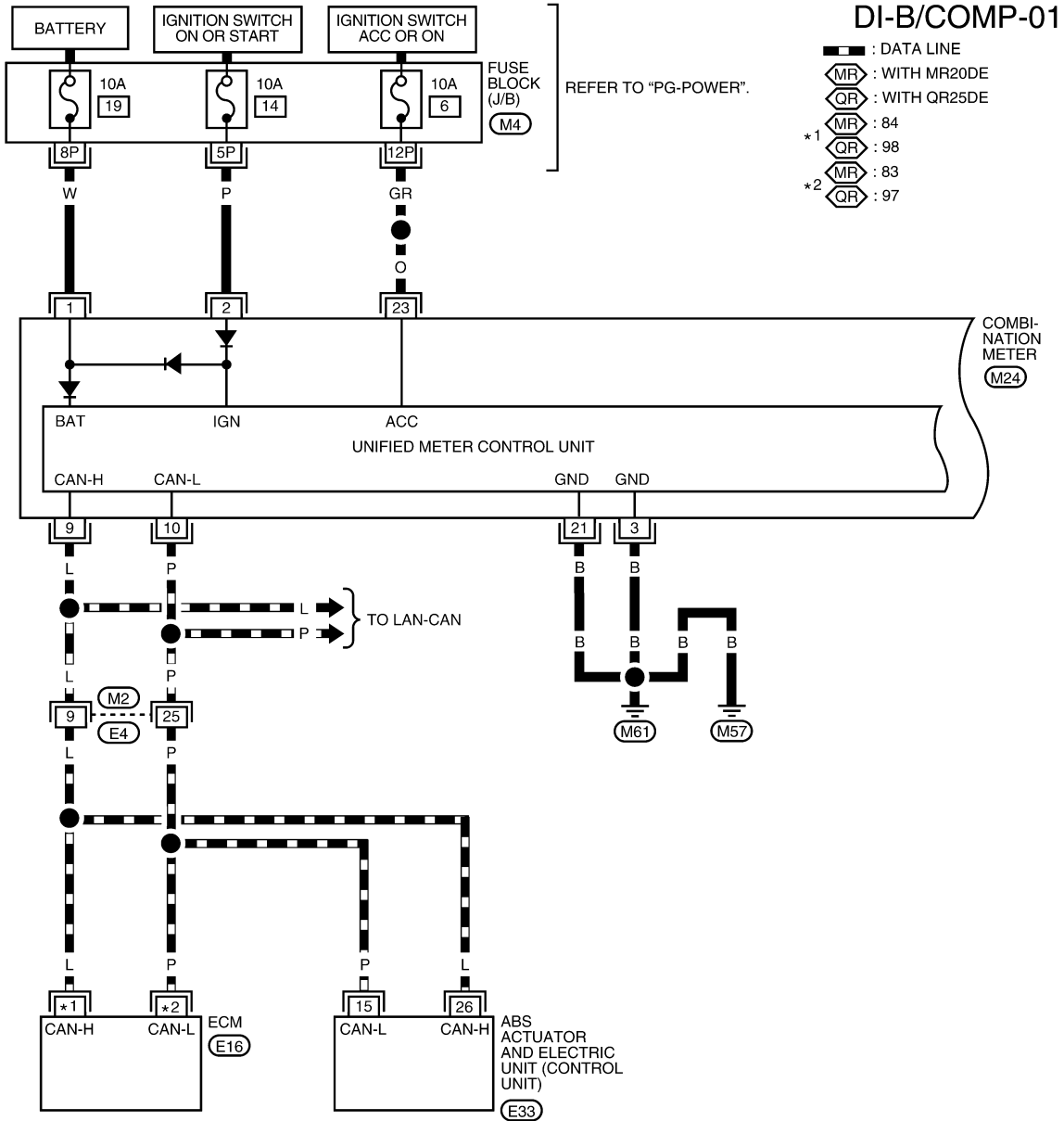

BOARD COMPUTER

< SERVICE INFORMATION >

DI-B/COMP-02

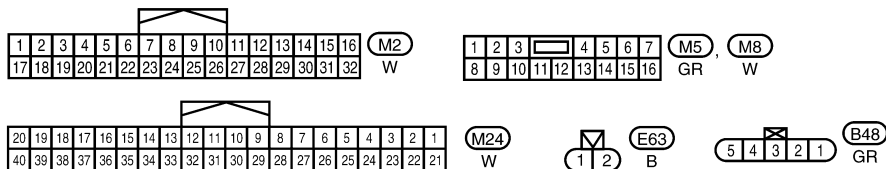
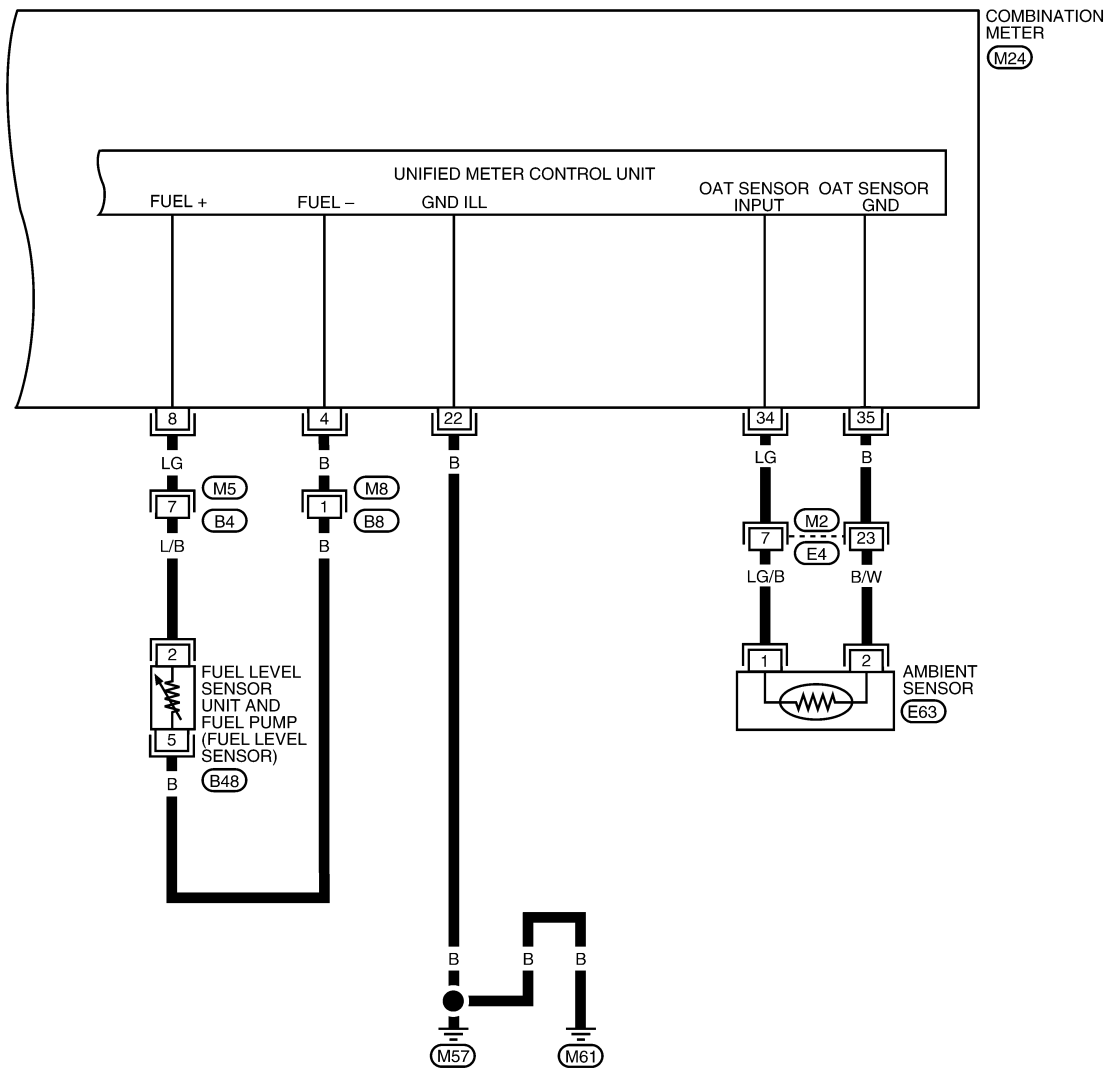

ABNWA0892GB

BOARD COMPUTER

< SERVICE INFORMATION >

Trouble Diagnosis

INFOID:000000007403123

DIAGNOSIS PROCEDURE

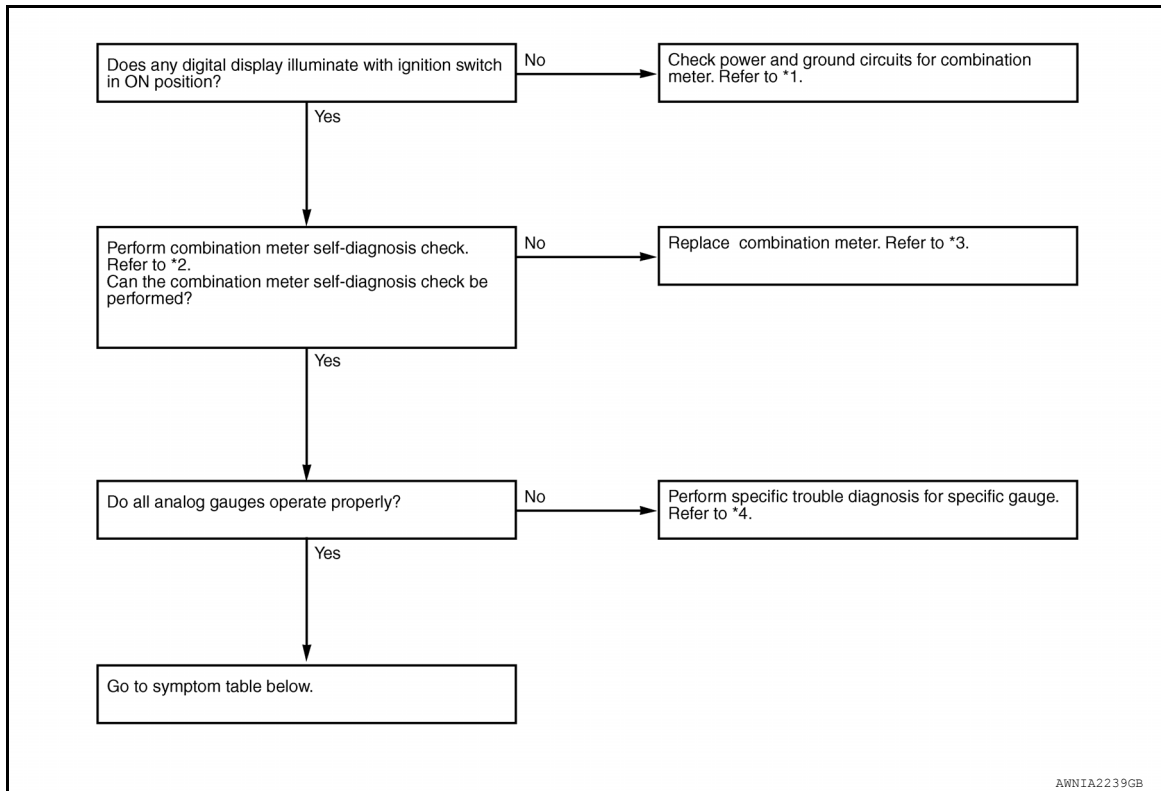

*1 [DI-18, "Power Supply and Ground Circuit Inspection"](#)

*2 [DI-14, "Self-Diagnosis Mode of Combination Meter"](#)

*3 [DI-22, "Removal and Installation"](#)

*4 [DI-17, "Trouble Diagnosis"](#)

SYMPTOM TABLE

Symptom	Possible cause	Repair order
Outside temperature is not displayed properly	<ul style="list-style-type: none"> Ambient air temperature signal circuit Ambient sensor 	<ol style="list-style-type: none"> Check ambient air temperature signal circuit. Refer to DI-76, "Ambient Air Temperature Signal Inspection". Check ambient temperature sensor. Refer to DI-77, "Electrical Component Inspection".
Distance to empty (DTE) is not displayed properly.	Fuel level sensor signal circuit	Make sure fuel level gauge operates properly. Refer to DI-19, "Fuel Level Sensor Signal Inspection" .
Trip distance is not indicated properly.	ABS actuator and electric unit (control unit)	Perform ABS actuator and electric unit (control unit) self diagnosis. Refer to BRC-24, "CONSULT Function (ABS)" .
Trip time is not indicated properly.	Power supply and ground to combination meter.	Check power supply and ground to combination meter. Refer to DI-18, "Power Supply and Ground Circuit Inspection" .
Average fuel consumption is not displayed properly.	<ul style="list-style-type: none"> Fuel level sensor signal circuit ABS actuator and electric unit (control unit) 	<ol style="list-style-type: none"> Make sure fuel level gauge operates properly. Refer to DI-19, "Fuel Level Sensor Signal Inspection". Perform ABS actuator and electric unit (control unit) self diagnosis. Refer to BRC-24, "CONSULT Function (ABS)".
Average vehicle speed is not indicated properly.	ABS actuator and electric unit (control unit)	Perform ABS actuator and electric unit (control unit) self diagnosis. Refer to BRC-24, "CONSULT Function (ABS)" .

Ambient Air Temperature Signal Inspection

INFOID:000000007403124

1. CHECK AMBIENT SENSOR CIRCUITS BETWEEN COMBINATION METER AND AMBIENT SENSOR

BOARD COMPUTER

< SERVICE INFORMATION >

1. Disconnect combination meter connector M24 and ambient sensor connector E63.
2. Check continuity between combination meter harness connector M24 (A) terminals 34, 35 and ambient sensor harness connector E63 (B) terminals 1 and 2.

A		B		Continuity
Connector	Terminal	Connector	Terminal	
M24	34	E63	1	Yes
	35		2	

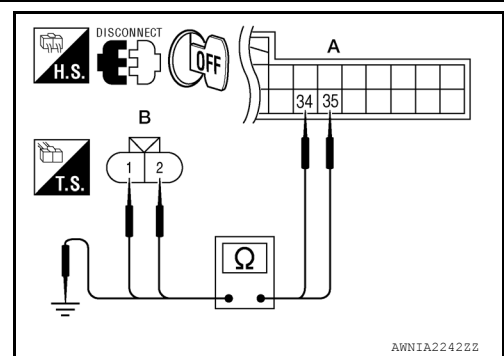

3. Check continuity between combination meter harness connector M24 (A) terminals 34, 35 and ground.

A		Ground	Continuity
Connector	Terminal		
M24	34		No
	35		

Is the inspection result normal?

YES >> GO TO 2.

NO >> Repair harness or connector.

2. CHECK AMBIENT SENSOR

Check ambient sensor. Refer to [DI-77. "Electrical Component Inspection"](#).

Is the inspection result normal?

YES >> Replace combination meter. Refer to [DI-22. "Removal and Installation"](#).

NO >> Replace ambient sensor.

Electrical Component Inspection

INFOID:000000007403125

AMBIENT SENSOR

After disconnecting the ambient sensor harness connector, measure resistance between ambient sensor terminals 1 and 2 using the table below.

Temperature °C (°F)	Resistance kΩ (Approx.)
-30 (-22)	28.62
-20 (-4)	16.50
-10 (14)	9.92
0 (32)	6.19
10 (50)	3.99
20 (68)	2.65
30 (86)	1.81
40 (104)	1.27
50 (122)	0.90
55 (131)	0.77
60 (140)	0.66

If NG, replace ambient sensor.

