

SECTION **RAX**
REAR AXLE

A
B
C

RAX

CONTENTS

E

PRECAUTION 2

PRECAUTIONS 2

 Precaution for Supplemental Restraint System (SRS) "AIR BAG" and "SEAT BELT PRE-TENSIONER"2

 General Precautions2

PREPARATION 3

PREPARATION 3

 Commercial Service Tools3

SYMPTOM DIAGNOSIS 4

NOISE, VIBRATION AND HARSHNESS (NVH) TROUBLESHOOTING 4

 NVH Troubleshooting Chart4

PERIODIC MAINTENANCE 5

REAR WHEEL HUB 5

 Inspection 5

REMOVAL AND INSTALLATION 6

REAR WHEEL HUB 6

 Exploded View - Drum brake 6

 Removal and Installation - Drum brake 6

 Exploded View - Disc brake 7

 Removal and Installation - Disc brake 7

 Inspection 8

SERVICE DATA AND SPECIFICATIONS (SDS) 9

SERVICE DATA AND SPECIFICATIONS (SDS) 9

 Wheel Bearing 9

F
G
H
I
J
K

L
M
N
O
P

PRECAUTIONS

< PRECAUTION >

PRECAUTION

PRECAUTIONS

Precaution for Supplemental Restraint System (SRS) "AIR BAG" and "SEAT BELT PRE-TENSIONER"

INFOID:000000008972841

The Supplemental Restraint System such as "AIR BAG" and "SEAT BELT PRE-TENSIONER", used along with a front seat belt, helps to reduce the risk or severity of injury to the driver and front passenger for certain types of collision. Information necessary to service the system safely is included in the SR and SB section of this Service Manual.

WARNING:

- To avoid rendering the SRS inoperative, which could increase the risk of personal injury or death in the event of a collision which would result in air bag inflation, all maintenance must be performed by an authorized NISSAN/INFINITI dealer.
- Improper maintenance, including incorrect removal and installation of the SRS, can lead to personal injury caused by unintentional activation of the system. For removal of Spiral Cable and Air Bag Module, see the SR section.
- Do not use electrical test equipment on any circuit related to the SRS unless instructed to in this Service Manual. SRS wiring harnesses can be identified by yellow and/or orange harnesses or harness connectors.

PRECAUTIONS WHEN USING POWER TOOLS (AIR OR ELECTRIC) AND HAMMERS

WARNING:

- When working near the Airbag Diagnosis Sensor Unit or other Airbag System sensors with the Ignition ON or engine running, DO NOT use air or electric power tools or strike near the sensor(s) with a hammer. Heavy vibration could activate the sensor(s) and deploy the air bag(s), possibly causing serious injury.
- When using air or electric power tools or hammers, always switch the Ignition OFF, disconnect the battery and wait at least 3 minutes before performing any service.

General Precautions

INFOID:000000008972848

- When installing each rubber part, final tightening must be carried out under unladen condition* with tires on ground.
*: Fuel, radiator coolant and engine oil full. Spare tire, jack, hand tools and mats in designated positions.
- After installing removed suspension parts, check wheel alignment.
- Do not jack up at the trailing arm and lateral link.

PREPARATION

< PREPARATION >

PREPARATION

PREPARATION

Commercial Service Tools

INFOID:000000008766231

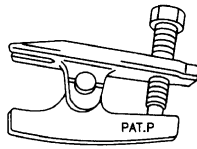
Tool name	Description
<p>Ball joint remover</p>  <p>NT146</p>	<p>Removing hub bolt</p>

A

B

C

RAX

E

F

G

H

I

J

K

L

M

N

O

P

NOISE, VIBRATION AND HARSHNESS (NVH) TROUBLESHOOTING

< SYMPTOM DIAGNOSIS >

SYMPTOM DIAGNOSIS

NOISE, VIBRATION AND HARSHNESS (NVH) TROUBLESHOOTING

NVH Troubleshooting Chart

INFOID:000000008766232

Use chart below to find the cause of the symptom. If necessary, repair or replace these parts.

Reference			RAX-7, "Exploded View - Disc brake"	—	RAX-5, "Inspection"	NVH in RAX and RSU sections	NVH in WT section	NVH in WT section	NVH in BR section
Possible cause and SUSPECTED PARTS			Improper installation, looseness	Parts interference	Wheel bearing damage	REAR AXLE AND REAR SUSPENSION	TIRE	ROAD WHEEL	BRAKE
Symptom	REAR AXLE	Noise	x	x	x	x	x	x	x
		Shake	x	x	x	x	x	x	x
		Vibration	x	x	x	x	x		
		Shimmy	x	x		x	x	x	x
		Shudder	x			x	x	x	x
		Poor quality ride or handling	x	x		x	x	x	

x: Applicable

REAR WHEEL HUB

< PERIODIC MAINTENANCE >

PERIODIC MAINTENANCE

REAR WHEEL HUB

Inspection

INFOID:000000008766233

COMPONENT PART

Check the mounting conditions (looseness, back lash) of each component and component conditions (wear, damage) are normal.

WHEEL HUB ASSEMBLY (BEARING-INTEGRATED TYPE)

Check the following items, and replace the part it necessary.

- Move wheel hub assembly in the axial direction by hand. Check there is no looseness of wheel bearing.

Axial end play : Refer to [RAX-9, "Wheel Bearing"](#).

- Rotate wheel hub assembly and check there is no unusual noise or other irregular conditions. If there is any of irregular conditions, replace wheel hub assembly.

A
B
C
RAX
E
F
G
H
I
J
K
L
M
N
O
P

REAR WHEEL HUB

< REMOVAL AND INSTALLATION >

REMOVAL AND INSTALLATION

REAR WHEEL HUB

Exploded View - Drum brake

INFOID:000000008972849

DRUM BRAKE

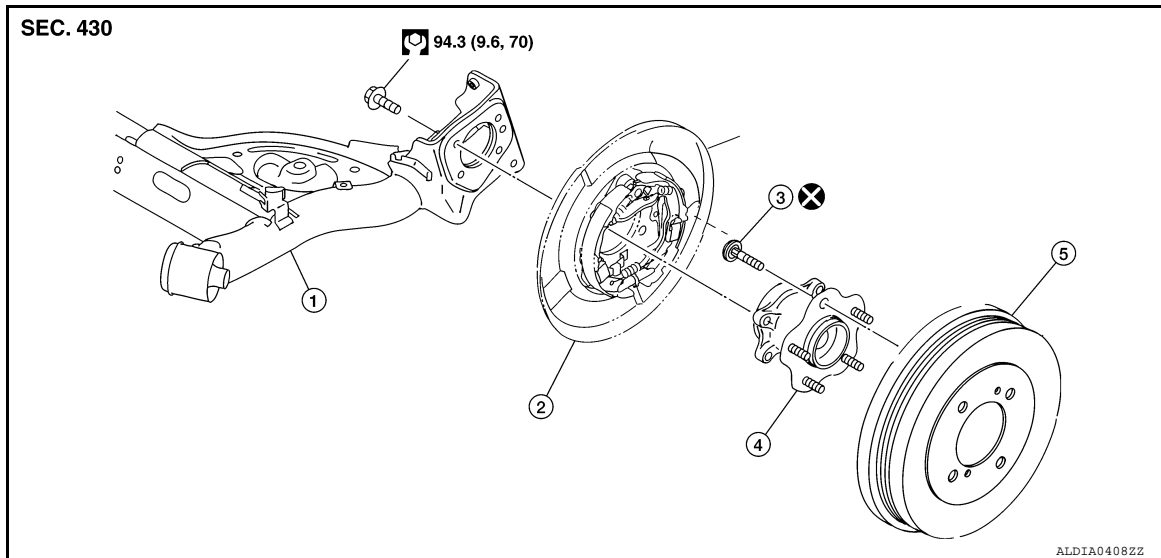

- | | | |
|---|-------------------|-------------|
| 1. Rear suspension beam | 2. Brake assembly | 3. Hub bolt |
| 4. Wheel hub assembly (Bearing-integrated type) | 5. Brake drum | |

Removal and Installation - Drum brake

INFOID:000000008972850

REMOVAL

1. Remove the wheel and tire using power tool. Refer to [WT-45, "Removal and Installation"](#).
2. Remove the rear wheel sensor bolt (1) and the rear wheel sensor (2). Refer to [BRC-105, "REAR WHEEL SENSOR : Removal and Installation"](#).

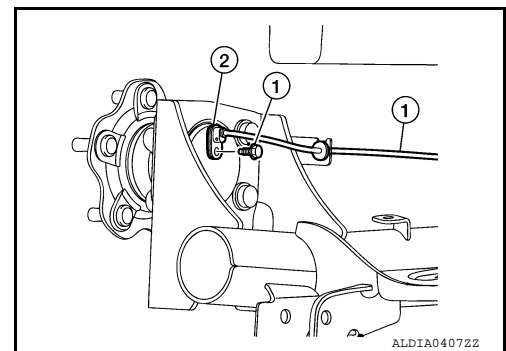

3. Remove rear brake drum. Refer to [BR-41, "Removal and Installation"](#).
CAUTION:
Do not depress brake pedal while rear brake drum is removed.
4. Remove the hub bolts and wheel hub assembly.
CAUTION:
Do not remove parking brake assembly. Protect it from falling.

INSTALLATION

Installation is in the reverse order of removal.

- Check that the wheel hub assembly operates smoothly
- Perform inspection after installation. Refer to [RAX-8, "Inspection"](#).

REAR WHEEL HUB

< REMOVAL AND INSTALLATION >

Exploded View - Disc brake

INFOID:000000008766234

DISK BRAKE

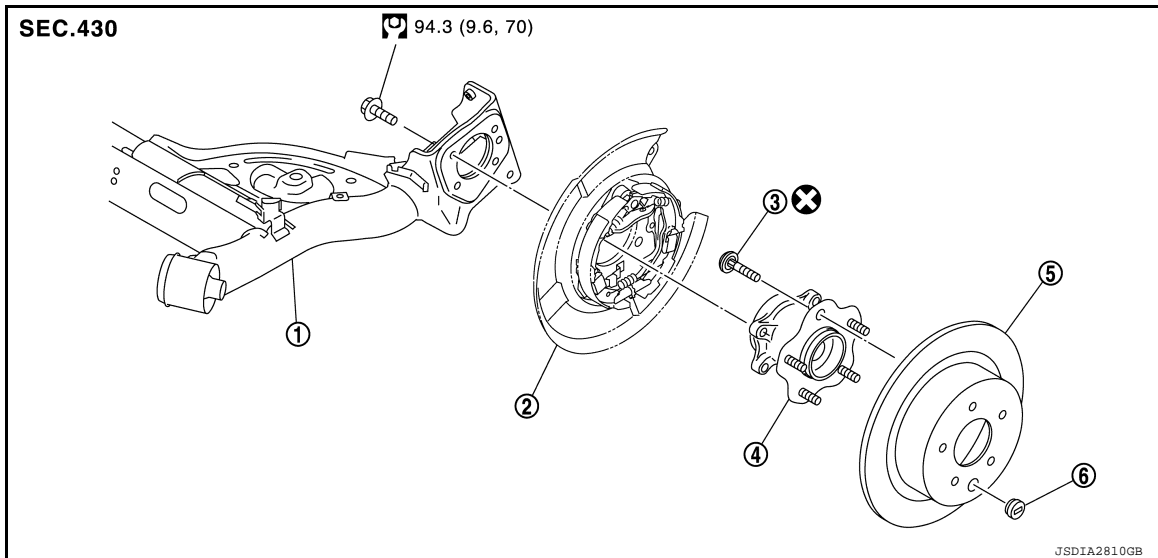

- | | | |
|---|---------------------------|-------------|
| 1. Rear suspension beam | 2. Parking brake assembly | 3. Hub bolt |
| 4. Wheel hub assembly (Bearing-integrated type) | 5. Disc rotor | 6. Plug |

Removal and Installation - Disc brake

INFOID:000000008766235

REMOVAL

1. Remove the wheel and tire using power tool. Refer to [WT-45, "Removal and Installation"](#).
2. Remove the rear wheel sensor bolt (1) and the rear wheel sensor (2). Refer to [BRC-105, "REAR WHEEL SENSOR : Removal and Installation"](#).

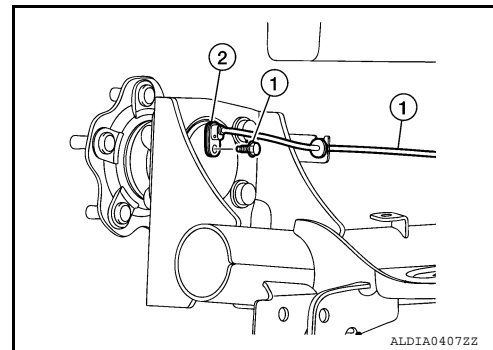

3. Remove the rear brake caliper assembly. Refer to [BR-46, "BRAKE CALIPER ASSEMBLY : Removal and Installation"](#).
CAUTION:
Do not depress brake pedal while rear brake assembly is removed.
4. Remove the hub bolts and wheel hub assembly.
CAUTION:
Do not remove parking brake assembly. Protect it from falling.

INSTALLATION

Installation is in the reverse order of removal.

- Align the matching marks that have been made during removal when reusing the disc rotor.
- Check that the wheel hub assembly operates smoothly
- Perform inspection after installation. Refer to [RAX-8, "Inspection"](#).

REAR WHEEL HUB

< REMOVAL AND INSTALLATION >

Inspection

INFOID:000000008766236

INSPECTION AFTER REMOVAL

Check the wheel hub assembly for wear, cracks, and damage. Replace if necessary.

INSPECTION AFTER INSTALLATION

1. Check wheel sensor harness for proper connection. Refer to [BRC-105, "REAR WHEEL SENSOR : Exploded View"](#).
2. Adjust parking brake operation (stroke). Refer to [PB-4, "Inspection and Adjustment"](#).
3. Check wheel alignment. Refer to [RSU-6, "Inspection"](#).

SERVICE DATA AND SPECIFICATIONS (SDS)

< SERVICE DATA AND SPECIFICATIONS (SDS)

SERVICE DATA AND SPECIFICATIONS (SDS)

SERVICE DATA AND SPECIFICATIONS (SDS)

Wheel Bearing

INFOID:000000008766237

Item	Standard
Axial end play	0.05 mm (0.002 in) or less

A

B

C

RAX

E

F

G

H

I

J

K

L

M

N

O

P