

SECTION **SR**
SRS AIRBAG

A
B
C
D
E
F
G
SR
I
J
K
L
M
N
O
P

CONTENTS

PRECAUTION	2	Removal and Installation	19
PRECAUTIONS	2	SIDE CURTAIN AIR BAG MODULE	22
Precaution for Supplemental Restraint System (SRS) "AIR BAG" and "SEAT BELT PRE-TENSIONER"	2	Exploded View	22
Service	2	Removal and Installation	22
Occupant Classification System	2	SIDE AIR BAG MODULE	24
Precaution for Work	2	Removal and Installation	24
PREPARATION	4	CRASH ZONE SENSOR	25
PREPARATION	4	Exploded View	25
Special Service Tools	4	Removal and Installation	25
BASIC INSPECTION	5	SIDE AIR BAG (SATELLITE) SENSOR	26
COLLISION DIAGNOSIS	5	Exploded View	26
For Frontal Collision	5	Removal and Installation	26
For Side and Rollover Collision	7	DIAGNOSIS SENSOR UNIT	28
REMOVAL AND INSTALLATION	12	Exploded View	28
DRIVER AIR BAG MODULE	12	Removal and Installation	28
Exploded View	12	OCCUPANT CLASSIFICATION SYSTEM	30
Removal and Installation	12	Removal and Installation	30
SPIRAL CABLE	16	SEAT BELT PRE-TENSIONER	31
Exploded View	16	Removal and Installation	31
Removal and Installation	16	FRONT SEAT BELT BUCKLE SWITCH	32
FRONT PASSENGER AIR BAG MODULE	19	Removal and Installation	32
Exploded View	19	PASSENGER AIR BAG INDICATOR	33
		Removal and Installation	33

PRECAUTIONS

< PRECAUTION >

PRECAUTION

PRECAUTIONS

Precaution for Supplemental Restraint System (SRS) "AIR BAG" and "SEAT BELT PRE-TENSIONER"

INFOID:000000008894285

The Supplemental Restraint System such as "AIR BAG" and "SEAT BELT PRE-TENSIONER", used along with a front seat belt, helps to reduce the risk or severity of injury to the driver and front passenger for certain types of collision. Information necessary to service the system safely is included in the SR and SB section of this Service Manual.

WARNING:

- To avoid rendering the SRS inoperative, which could increase the risk of personal injury or death in the event of a collision which would result in air bag inflation, all maintenance must be performed by an authorized NISSAN/INFINITI dealer.
- Improper maintenance, including incorrect removal and installation of the SRS, can lead to personal injury caused by unintentional activation of the system. For removal of Spiral Cable and Air Bag Module, see the SR section.
- Do not use electrical test equipment on any circuit related to the SRS unless instructed to in this Service Manual. SRS wiring harnesses can be identified by yellow and/or orange harnesses or harness connectors.

PRECAUTIONS WHEN USING POWER TOOLS (AIR OR ELECTRIC) AND HAMMERS

WARNING:

- When working near the Airbag Diagnosis Sensor Unit or other Airbag System sensors with the Ignition ON or engine running, DO NOT use air or electric power tools or strike near the sensor(s) with a hammer. Heavy vibration could activate the sensor(s) and deploy the air bag(s), possibly causing serious injury.
- When using air or electric power tools or hammers, always switch the Ignition OFF, disconnect the battery and wait at least 3 minutes before performing any service.

Service

INFOID:000000008832989

- Do not use electrical test equipment to check SRS circuits unless instructed to in this Service Manual.
- Before servicing the SRS, turn ignition switch OFF, disconnect both battery cables and wait at least three minutes.
For approximately three minutes after the cables are removed, it is still possible for the air bag and seat belt pre-tensioner to deploy. Therefore, do not work on any SRS connectors or wires until at least three minutes have passed.
- Diagnosis sensor unit must always be installed with their arrow marks "←" pointing towards the front of the vehicle for proper operation. Also check diagnosis sensor unit for cracks, deformities or rust before installation and replace as required.
- The spiral cable must be aligned with the neutral position since its rotations are limited. Do not turn steering wheel and column after removal of steering gear.
- Handle air bag module carefully. Always place driver and front passenger air bag modules with the pad side facing upward and seat mounted front side air bag module standing with the stud bolt side facing down.
- Conduct self-diagnosis to check entire SRS for proper function after replacing any components.
- After air bag inflates, the instrument panel assembly should be replaced if damaged.
- Always replace instrument panel pad following front passenger air bag deployment.

Occupant Classification System

INFOID:000000008832990

The occupant classification system control unit and the occupant classification system sensors are serviced with the front passenger seat frame assembly. For disassembly and assembly of the front passenger seat frame assembly, refer to [SE-36, "PASSENGER SIDE : Disassembly and Assembly"](#).

Precaution for Work

INFOID:000000008832991

- When removing or disassembling each component, be careful not to damage or deform it. If a component may be subject to interference, be sure to protect it with a shop cloth.

PRECAUTIONS

< PRECAUTION >

- When removing (disengaging) components with a screwdriver or similar tool, be sure to wrap the component with a shop cloth or vinyl tape to protect it. A
- Protect the removed parts with a shop cloth and prevent them from being dropped.
- Replace a deformed or damaged clip.
- If a part is specified as a non-reusable part, always replace it with a new one. B
- Be sure to tighten bolts and nuts securely to the specified torque.
- After installation is complete, be sure to check that each part works properly.
- Follow the steps below to clean components:
 - Water soluble dirt: C
 - Dip a soft cloth into lukewarm water, wring the water out of the cloth and wipe the dirty area.
 - Then rub with a soft, dry cloth.
 - Oily dirt: D
 - Dip a soft cloth into lukewarm water with mild detergent (concentration: within 2 to 3%) and wipe the dirty area.
 - Then dip a cloth into fresh water, wring the water out of the cloth and wipe the detergent off. E
 - Then rub with a soft, dry cloth.
 - Do not use organic solvent such as thinner, benzene, alcohol or gasoline.
 - For genuine leather seats, use a genuine leather seat cleaner. F

SR

I

J

K

L

M

N

O

P

PREPARATION

< PREPARATION >

PREPARATION

PREPARATION

Special Service Tools

INFOID:000000008832992

The actual shapes of Kent-Moore tools may differ from those of special service tools illustrated here.

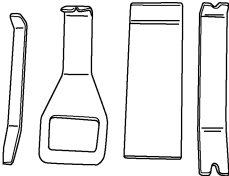
Tool number (Kent-Moore No.) Tool name	Description
— (J-46534) Trim Tool Set  AWJIA0483ZZ	Removing trim components

COLLISION DIAGNOSIS

< BASIC INSPECTION >

BASIC INSPECTION

COLLISION DIAGNOSIS

For Frontal Collision

INFOID:000000009017020

FOR FRONTAL COLLISION: When SRS is activated in a collision

CAUTION:

Due to varying models and option levels, not all parts listed in the chart below apply to all vehicles.

WORK PROCEDURE

1. Before performing any of the following steps, ensure that all vehicle body and structural repairs have been completed.
2. Replace the diagnosis sensor unit.
3. Remove the front air bag modules, crash zone sensor assembly, bracket and seat belt pre-tensioner assemblies.
4. Check the SRS components using the table below:
Replace any SRS components showing visible signs of damage. (dents, cracks and deformation, etc.)
5. Install new front air bag modules, crash zone sensor assembly, bracket and seat belt pre-tensioner assemblies.
6. Perform self-diagnosis using CONSULT or air bag warning lamp. Refer to [SRC-16. "Trouble Diagnosis with CONSULT"](#) for details.
Ensure entire SRS operates properly.
7. After the work is completed, perform self-diagnosis to check that no malfunction is detected. Refer to [SRC-41. "ADDITIONAL SERVICE WHEN REPLACING CONTROL UNIT : Special Repair Requirement"](#).

SRS INSPECTION (FOR FRONTAL COLLISION)

Part	Inspection
Driver air bag module	If the driver air bag has deployed: REPLACE Install with new fasteners.
Front passenger air bag module (if equipped)	If the front passenger air bag has deployed: REPLACE Install with new fasteners.
Crash zone sensor	If any of the front air bags or seat belt pre-tensioners* have been activated: REPLACE the crash zone sensor and bracket with new fasteners. *: Confirm seat belt pre-tensioner activation using CONSULT only.
Seat belt pre-tensioner assemblies (All applicable locations: buckle, retractor, lap outer)	If either the driver or passenger seat belt pre-tensioner* has been activated: REPLACE all seat belt pre-tensioner assemblies with new fasteners. *: Confirm seat belt pre-tensioner activation using CONSULT only.
Diagnosis sensor unit	If any of the SRS components have been activated: REPLACE the diagnosis sensor unit. Install with new fasteners.
Steering wheel	<ol style="list-style-type: none"> 1. Visually check steering wheel for deformities. 2. Check harness (built into steering wheel) and connectors for damage, and terminals for deformities. 3. Install driver air bag module into the steering wheel to check fit and alignment with the wheel. 4. Check steering wheel for excessive free play. 5. If no damage is found, reinstall. 6. If damaged — REPLACE.
Spiral cable	If the driver front air bag has deployed: REPLACE the spiral cable.

COLLISION DIAGNOSIS

< BASIC INSPECTION >

Part	Inspection
Occupant classification system (Passenger seat)	<ol style="list-style-type: none"> 1. Remove passenger seat assembly. 2. Check control unit case for dents, cracks or deformities. 3. Check connectors for damage and terminals for deformities. 4. Check seat frame and cushion pan for dents or deformities. 5. If no damage is found, reinstall seat with new fasteners. 6. If damaged — REPLACE seat cushion assembly with new fasteners. 7. Perform zero point reset function after front passenger seat is installed in the vehicle and all bolts are tightened to specification. Refer to SRC-41, "ZERO POINT RESET : Special Repair Requirement".
Harness and connectors	<ol style="list-style-type: none"> 1. Check connectors for poor connection, damage, and terminals for deformities. 2. Check harness for binding, chafing, cuts, or deformities. 3. If no damage is found, reinstall the harness and connectors. 4. If damaged — REPLACE the damaged harness. Do not attempt to repair, splice or modify any SRS harness.
Instrument panel assembly	If the passenger front air bag has deployed: REPLACE the instrument panel assembly. (integrated type)

FOR FRONTAL COLLISION: When SRS is not activated in a collision

CAUTION:

Due to varying models and option levels, not all parts listed in the chart below apply to all vehicles.

WORK PROCEDURE

1. Before performing any of the following steps, ensure that all vehicle body and structural repairs have been completed.
2. Check the SRS components using the table below:
Replace any SRS components showing visible signs of damage. (dents, cracks and deformation, etc.)
3. Perform self-diagnosis using CONSULT or air bag warning lamp. Refer to [SRC-17, "Trouble Diagnosis without CONSULT"](#) for details.
Ensure entire SRS operates properly.
4. After the work is completed, perform self-diagnosis to check that no malfunction is detected. Refer to [SRC-41, "ADDITIONAL SERVICE WHEN REPLACING CONTROL UNIT : Special Repair Requirement"](#).

SRS INSPECTION (FOR FRONTAL COLLISION)

Part	Inspection
Driver air bag module	<p>If the driver air bag has NOT been activated:</p> <ol style="list-style-type: none"> 1. Remove driver air bag module. Check harness cover and connectors for damage, terminals for deformities, and harness for binding. 2. Install driver air bag module into the steering wheel to check fit and alignment with the wheel. 3. If no damage is found, reinstall with new fasteners. 4. If damaged — REPLACE. Install driver air bag modules with new fasteners.
Front passenger air bag module (if equipped)	<p>If the front passenger air bag has NOT been activated:</p> <ol style="list-style-type: none"> 1. Remove front passenger air bag module. Check harness cover and connectors for damage, terminals for deformities, and harness for binding. 2. Install front passenger air bag module into the instrument panel to check fit with the instrument panel. 3. If no damage is found, reinstall with new fasteners. 4. If damaged — REPLACE. Install front passenger air bag modules with new fasteners.
Crash zone sensor	<p>If the front air bags or seat belt pre-tensioners have NOT been activated:</p> <ol style="list-style-type: none"> 1. Remove the crash zone sensor. Check harness connectors for damage, terminals for deformities, and harness for binding. 2. Check for visible signs of damage (dents, cracks, deformation) of the crash zone sensor and bracket. 3. Install the crash zone sensor to check fit. 4. If no damage is found, reinstall with new fasteners. 5. If damaged — REPLACE the crash zone sensor and bracket with new fasteners.

COLLISION DIAGNOSIS

< BASIC INSPECTION >

Part	Inspection	
Seat belt pre-tensioner assemblies (All applicable locations: buckle, retractor, lap outer)	If the pre-tensioners have NOT been activated: <ol style="list-style-type: none"> 1. Remove seat belt pre-tensioners. Check harness cover and connectors for damage, terminals for deformities, and harness for binding. 2. Check belts for damage and anchors for loose mounting. 3. Check retractor for smooth operation. 4. Check seat belt adjuster for damage. 5. Check for deformities of the center pillar inner. 6. If the center pillar inner has no damage, REPLACE the seat belt pre-tensioner assembly. 7. If no damage is found, reinstall seat belt pre-tensioner assembly. 8. If damaged —REPLACE. Install the seat belt pre-tensioners with new fasteners. 	A B C
Diagnosis sensor unit	If none of the SRS components have been activated: <ol style="list-style-type: none"> 1. Check case for dents, cracks or deformities. 2. Check connectors for damage, and terminals for deformities. 3. If no damage is found, reinstall with new fasteners. 4. If damaged — REPLACE. Install diagnosis sensor unit with new fasteners. 	D E
Steering wheel	<ol style="list-style-type: none"> 1. Visually check steering wheel for deformities. 2. Check harness (built into steering wheel) and connectors for damage, and terminals for deformities. 3. Install driver air bag module into the steering wheel to check fit and alignment with the wheel. 4. Check steering wheel for excessive free play. 5. If no damage is found, reinstall. 6. If damaged — REPLACE. 	F G
Spiral cable	If the driver front air bag has not deployed: <ol style="list-style-type: none"> 1. Visually check spiral cable and combination switch for damage. 2. Check connectors and protective tape for damage. 3. Check steering wheel for noise, binding or heavy operation. 4. If no damage is found, reinstall. 5. If damaged — REPLACE. 	SR
Occupant classification system (Passenger seat)	<ol style="list-style-type: none"> 1. Remove passenger seat assembly. 2. Check control unit case for dents, cracks or deformities. 3. Check connectors for damage and terminals for deformities. 4. Check seat frame and cushion pan for dents or deformities. 5. If no damage is found, reinstall seat with new fasteners. 6. If damaged — REPLACE seat cushion assembly with new fasteners. 7. Perform zero point reset function after front passenger seat is installed in the vehicle and all bolts are tightened to specification. Refer to SRC-41, "ZERO POINT RESET : Special Repair Requirement". 	I J K
Harness and connectors	<ol style="list-style-type: none"> 1. Check connectors for poor connection, damage, and terminals for deformities. 2. Check harness for binding, chafing, cuts, or deformities. 3. If no damage is found, reinstall the harness and connectors. 4. If damaged —REPLACE the damaged harness. Do not attempt to repair, splice or modify any SRS harness. 	L M
Instrument panel assembly	If the passenger front air bag has NOT deployed: <ol style="list-style-type: none"> 1. Visually check instrument panel for damage. 2. If no damage is found, reinstall the instrument panel assembly. 3. If damaged—REPLACE the instrument panel assembly. 	N

For Side and Rollover Collision

INFOID:000000009017021

FOR SIDE AND ROLLOVER COLLISION: When SRS is activated in a collision

CAUTION:

Due to varying models and option levels, not all parts listed in the chart below apply to all vehicles.

WORK PROCEDURE

1. Before performing any of the following steps, ensure that all vehicle body and structural repairs have been completed.
2. Replace the following components:
 - Front seat back assembly (on the side on which side air bag is activated).
 - Door finisher (on the side on which door-mounted curtain air bag is activated).
 - Pop-up roll bar assemblies and pop-up roll bar covers.

COLLISION DIAGNOSIS

< BASIC INSPECTION >

- Side air bag (satellite) sensor LH/RH (on the side on which side air bag is activated).
 - Diagnosis sensor unit.
 - Seat belt pre-tensioner assemblies.
3. Check the SRS components and the related parts using the following table.
Replace any SRS components and the related parts showing visible signs of damage (dents, cracks, deformation, etc.).
 4. Perform self-diagnosis using CONSULT and "AIR BAG" warning lamp. Refer to [SRC-41, "ADDITIONAL SERVICE WHEN REPLACING CONTROL UNIT : Special Repair Requirement"](#) for details. Make sure entire SRS operates properly.
 5. After the work is completed, perform self-diagnosis to check that no malfunction is detected. Refer to [SRC-17, "Trouble Diagnosis without CONSULT"](#).

SRS INSPECTION (FOR SIDE AND ROLLOVER COLLISION)

Part	Inspection
Side curtain air bag module LH	If the side curtain air bag LH has deployed: REPLACE the side curtain air bag module LH. Install with new fasteners.
Side curtain air bag module RH	If the side curtain air bag RH has deployed: REPLACE the side curtain air bag module RH. Install with new fasteners.
Front side air bag module LH	If the front side air bag LH has deployed: REPLACE front seatback assembly LH.
Front side air bag module RH	If the front side air bag RH has deployed: REPLACE front seatback assembly RH.
Side air bag (satellite) sensor (LH or RH)	If any of the SRS components have deployed: REPLACE the side air bag (satellite) sensor on the collision side with new fasteners.
Door (satellite) sensor (LH or RH)	If any of the SRS components have deployed: REPLACE the door (satellite) sensor on the collision side with new fasteners.
Diagnosis sensor unit	If any of the SRS components have deployed: REPLACE the diagnosis sensor unit with new fasteners.
Seat belt pre-tensioner assemblies (All applicable locations: buckle, retractor, lap outer)	If either the driver or passenger seat belt pre-tensioner* has been activated: REPLACE all seat belt pre-tensioner assemblies with new fasteners. *: Confirm seat belt pre-tensioner activation using CONSULT only.
Center inner pillar	1. Check the center inner pillar on the collision side for damage (dents, cracks, deformation). 2. If damaged —REPAIR the center inner pillar.
Seat (if equipped with front side air bag)	If either the front LH or front RH side air bag modules has been deployed: REPLACE front seatback assembly on the deployed side.
Trim/headlining	1. Check for visible signs of damage (dents, cracks, deformation) of the interior trim on the collision side. 2. If damaged — REPLACE the damaged trim parts.
Door-mounted curtain air bag module LH	If the door-mounted curtain air bag module LH has been deployed: REPLACE the door finisher LH and door-mounted curtain air bag module. Install with new fasteners.
Door-mounted curtain air bag module RH	If the door-mounted curtain air bag module RH has been deployed: REPLACE the door finisher RH and door-mounted curtain air bag module. Install with new fasteners.

COLLISION DIAGNOSIS

< BASIC INSPECTION >

Part	Inspection	A
Occupant classification system (Passenger seat)	<ol style="list-style-type: none"> 1. Remove passenger seat assembly. 2. Check control unit case for dents, cracks or deformities. 3. Check connectors for damage and terminals for deformities. 4. Check seat frame and cushion pan for dents or deformities. 5. If no damage is found, reinstall seat with new fasteners. 6. If damaged — REPLACE seat cushion assembly with new fasteners. 7. Perform zero point reset function after front passenger seat is installed in the vehicle and all bolts are tightened to specification. Refer to SRC-41, "ZERO POINT RESET : Special Repair Requirement". 	B C
Pop-up roll bar assemblies	If the pop-up roll bar has deployed: REPLACE pop-up roll bar assemblies and pop-up roll bar covers. Install with new fasteners.	D

FOR SIDE AND ROLLOVER COLLISION: When SRS is not activated in a collision

CAUTION:

Due to varying models and option levels, not all parts listed in the chart below apply to all vehicles.

WORK PROCEDURE

1. Before performing any of the following steps, ensure that all vehicle body and structural repairs have been completed.
2. Check the SRS components and the related parts using the following table.
 - If the front seat back assembly is damaged, the front seat back assembly must be replaced.
 - If the door finisher assembly is damaged, the door finisher assembly and door-mounted curtain air bag module must be replaced.
3. Perform self-diagnosis using CONSULT and "AIR BAG" warning lamp. Refer to [SRC-41, "ADDITIONAL SERVICE WHEN REPLACING CONTROL UNIT : Special Repair Requirement"](#) for details. Make sure entire SRS operates properly.
4. After the work is completed, perform self-diagnosis to check that no malfunction is detected. Refer to [SRC-17, "Trouble Diagnosis without CONSULT"](#).

SRS INSPECTION (FOR SIDE AND ROLLOVER COLLISION)

Part	Inspection	J
Side curtain air bag module LH	If the side curtain air bag LH has NOT deployed: <ol style="list-style-type: none"> 1. Check for visible signs of damage (dents, tears, deformation) of the center pillar on the collision side. 2. If damaged - Remove the side curtain air bag module LH. 3. Check for visible signs of damage (tears etc.) of the side curtain air bag module LH. 4. Check harness and connectors for damage, and terminals for deformities. 5. If no damage is found, reinstall the side curtain air bag module LH with new fasteners. 6. If damaged — REPLACE the side curtain air bag module LH with new fasteners. 	K L
Side curtain air bag module RH	If the side curtain air bag RH has NOT deployed: <ol style="list-style-type: none"> 1. Check for visible signs of damage (dents, tears, deformation) of the center pillar on the collision side. 2. If damaged - Remove the side curtain air bag module RH. 3. Check for visible signs of damage (tears etc.) of the side curtain air bag module RH. 4. Check harness and connectors for damage, and terminals for deformities. 5. If no damage is found, reinstall the side curtain air bag module RH with new fasteners. 6. If damaged — REPLACE the side curtain air bag module RH with new fasteners. 	M N
Front side air bag module LH	If the front LH side air bag has NOT deployed: <ol style="list-style-type: none"> 1. Check for visible signs of damage (dents, tears, deformation) of the seat back on the collision side. 2. Check harness and connectors for damage, and terminals for deformities. 3. If damaged — REPLACE the front seatback assembly LH. 	O P
Front side air bag module RH	If the front side air bag RH has NOT deployed: <ol style="list-style-type: none"> 1. Check for visible signs of damage (dents, tears, deformation) of the seat back on the collision side. 2. Check harness and connectors for damage, and terminals for deformities. 3. If damaged — REPLACE the front seatback assembly RH. 	

COLLISION DIAGNOSIS

< BASIC INSPECTION >

Part	Inspection
Side air bag (satellite) sensor (LH or RH)	<p>If none of the SRS components have been activated:</p> <ol style="list-style-type: none"> 1. Remove the side air bag (satellite) sensor (LH or RH) on the collision side. Check harness connectors for damage, terminals for deformities, and harness for binding. 2. Check for visible signs of damage (dents, cracks, deformation) of the side air bag (satellite) sensor (LH or RH). 3. Install the side air bag (satellite) sensor (LH or RH) to check fit. 4. If no damage is found, reinstall the side air bag (satellite) sensor (LH or RH) with new fasteners. 5. If damaged — REPLACE the side air bag (satellite) sensor (LH or RH) with new fasteners.
Door (satellite) sensor (LH or RH)	<p>If none of the SRS components have been activated:</p> <ol style="list-style-type: none"> 1. Remove the door (satellite) sensor (LH or RH) on the collision side. Check harness connectors for damage, terminals for deformities, and harness for binding. 2. Check for visible signs of damage (dents, cracks, deformation) of the door (satellite) sensor (LH or RH). 3. Install the door (satellite) sensor (LH or RH) to check fit. 4. If no damage is found, reinstall the door (satellite) sensor (LH or RH) with new fasteners. 5. If damaged — REPLACE the door (satellite) sensor (LH or RH) with new fasteners.
Diagnosis sensor unit	<p>If none of the SRS components have been activated:</p> <ol style="list-style-type: none"> 1. Check case and bracket for dents, cracks or deformities. 2. Check connectors for damage, and terminals for deformities. 3. If no damage is found, reinstall the diagnosis sensor unit with new fasteners. 4. If damaged — REPLACE the diagnosis sensor unit with new fasteners.
Seat belt pre-tensioner assemblies (All applicable locations: buckle, retractor, lap outer)	<p>If the pre-tensioners have NOT been activated:</p> <ol style="list-style-type: none"> 1. Remove seat belt pre-tensioners. Check harness cover and connectors for damage, terminals for deformities, and harness for binding. 2. Check belts for damage and anchors for loose mounting. 3. Check retractor for smooth operation. 4. Check seat belt adjuster for damage. 5. Check for deformities of the center pillar inner. 6. If the center pillar inner has no damage, REPLACE the seat belt pre-tensioner assembly. 7. If no damage is found, reinstall seat belt pre-tensioner assembly. 8. If damaged —REPLACE. Install the seat belt pre-tensioners with new fasteners.
Seat (with front side air bag)	<p>If the front LH or front RH side air bag modules have NOT deployed:</p> <ol style="list-style-type: none"> 1. Visually check the seat on the collision side. 2. Remove the seat on the collision side and check the following for damage and deformities. <ul style="list-style-type: none"> - Harness, connectors and terminals - Frame and recliner (for front and rear seat), and also adjuster and slides (for front seat) 3. If no damage is found, reinstall the seat. 4. If damaged— REPLACE the damaged seat parts using new fasteners. If the front seat back is damaged, the front seat back assembly must be replaced.
Center inner pillar	<ol style="list-style-type: none"> 1. Check the center inner pillar on the collision side for damage (dents, cracks, deformation, etc.). 2. If damaged - REPAIR the center inner pillar.
Trim/headlining	<ol style="list-style-type: none"> 1. Check for visible signs of damage (dents, cracks, deformation, etc.) of the interior trim on the collision side. 2. If damaged - REPLACE the damaged trim parts.
Door-mounted curtain air bag module LH	<p>If the door-mounted curtain air bag LH has NOT deployed:</p> <ol style="list-style-type: none"> 1. Check for visible signs of damage (dents, tears, deformation, etc.) of the door finisher on the collision side. 2. If damaged - REPLACE the door finisher LH with new fasteners. 3. Check for visible signs of damage (tears etc.) of the door-mounted curtain air bag module LH. 4. Check harness and connectors for damage, and terminals for deformities. 5. If no damage is found, reinstall door finisher. CAUTION: When removing door mounted curtain air bag module from door finisher, do not reuse door finisher. 6. If damaged - REPLACE the door finisher LH and door-mounted curtain air bag module LH with new fasteners.

COLLISION DIAGNOSIS

< BASIC INSPECTION >

Part	Inspection	
Door-mounted curtain air bag module RH	<p>If the door-mounted curtain air bag RH has NOT deployed:</p> <ol style="list-style-type: none"> 1. Check for visible signs of damage (dents, tears, deformation, etc.) of the door finisher on the collision side. 2. If damaged - REPLACE the door finisher RH with new fasteners. 3. Check for visible signs of damage (tears etc.) of the door-mounted curtain air bag module RH. 4. Check harness and connectors for damage, and terminals for deformities. 5. If no damage is found, reinstall door finisher. <p>CAUTION: When removing door mounted curtain air bag module from door finisher, do not reuse door finisher.</p> <ol style="list-style-type: none"> 6. If damaged - REPLACE the door finisher RH and door-mounted curtain air bag module RH with new fasteners. 	A B C D
Occupant classification system (Passenger seat)	<ol style="list-style-type: none"> 1. Remove passenger seat assembly. 2. Check control unit case for dents, cracks or deformities. 3. Check connectors for damage and terminals for deformities. 4. Check seat frame and cushion pan for dents or deformities. 5. If no damage is found, reinstall seat with new fasteners. 6. If damaged — REPLACE seat cushion assembly with new fasteners. 7. Perform zero point reset function after front passenger seat is installed in the vehicle and all bolts are tightened to specification. Refer to SRC-41, "ZERO POINT RESET : Special Repair Requirement". 	E F
Pop-up roll bar	<p>If the pop-up roll bar NOT deployed:</p> <ol style="list-style-type: none"> 1. Check for visible signs of damage (dents, tears, deformation, etc.) of the pop-up roll bar. 2. If damaged - REPLACE the pop-up roll bar with new fasteners. 3. Check harness and connectors for damage, and terminals for deformities. 4. If no damage is found, reinstall the pop-up roll bar with new fasteners. 5. Check for visible signs of damage (dents, cracks, deformation, etc.) of the seatback support brace assembly. 6. If damaged - REPAIR the seatback support brace assembly. 	G SR I

DRIVER AIR BAG MODULE

< REMOVAL AND INSTALLATION >

REMOVAL AND INSTALLATION

DRIVER AIR BAG MODULE

Exploded View

INFOID:000000008832995

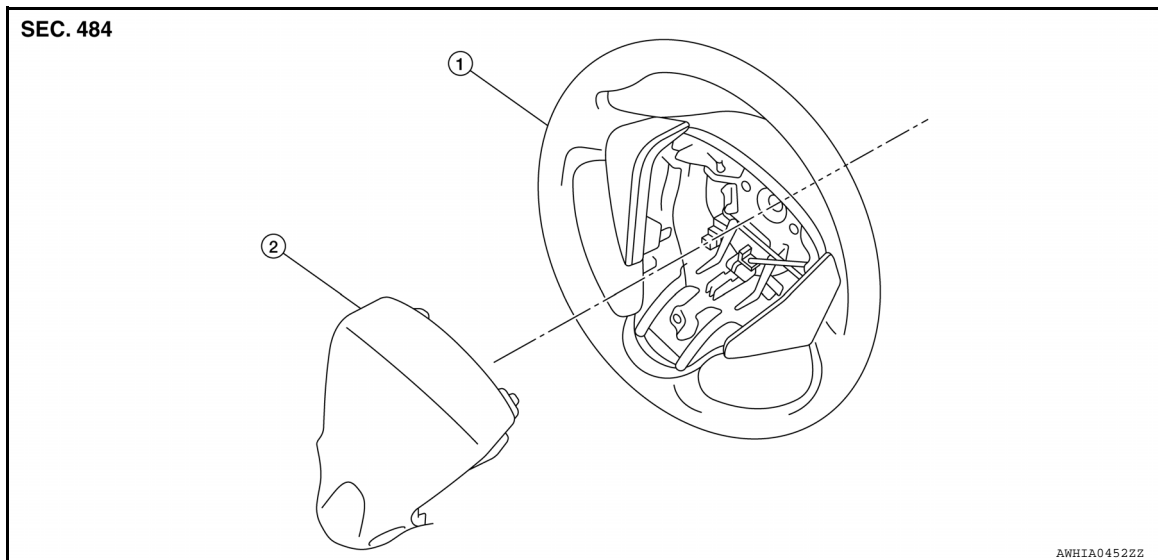

1. Steering wheel

2. Driver air bag module

Removal and Installation

INFOID:000000008832996

WARNING:

- Before servicing the SRS, turn ignition switch OFF, disconnect both battery terminals and wait at least three minutes.
- Always work from the side of air bag module. Do not work in front of it.
- Do not use air tools or electric tools for servicing.

REMOVAL

1. Disconnect both the negative and positive battery terminals, then wait at least three minutes. Refer to [PG-50, "Removal and Installation \(Battery\)"](#).

DRIVER AIR BAG MODULE

< REMOVAL AND INSTALLATION >

2. Locate retaining spring access holes in steering wheel rear finisher (1) and insert (←) a 5.0 mm (0.20 in) diameter suitable tool.
3. Make sure tool contacts retaining spring (A) as shown. While pushing suitable tool inward (←), push in top of driver air bag module at location (D) to release retaining spring (A) and pull to separate from steering wheel. This action will release the retaining spring from the steering wheel. Repeat action with retaining spring (B) while pushing at location (C).

NOTE:

Back side of driver air bag module is shown for clarity.

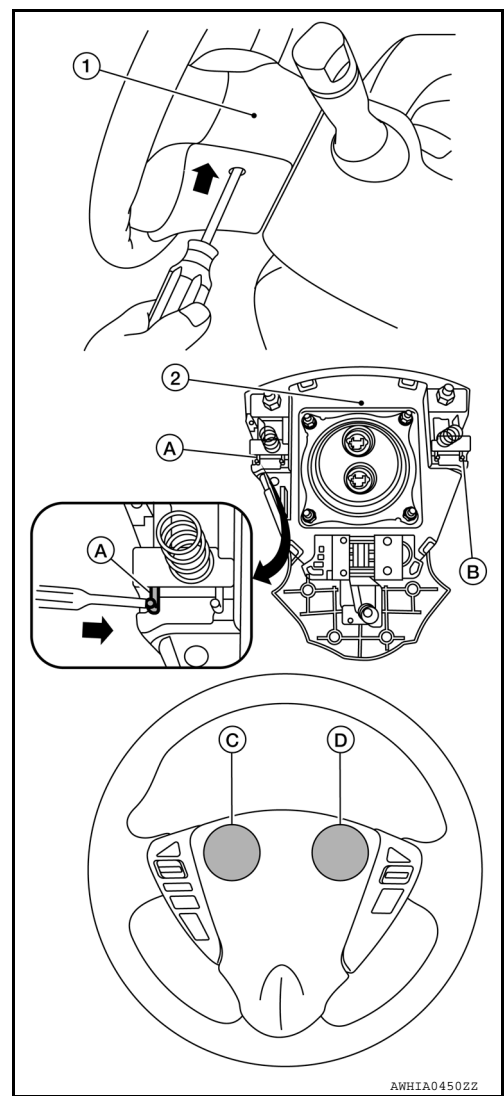

4. Raise the driver air bag module away from the steering wheel and disconnect the air bag harness connectors (A) and the horn terminal connector (B). Then remove the wire harness from the hook (←).

NOTE:

Dual stage driver air bag module shown.

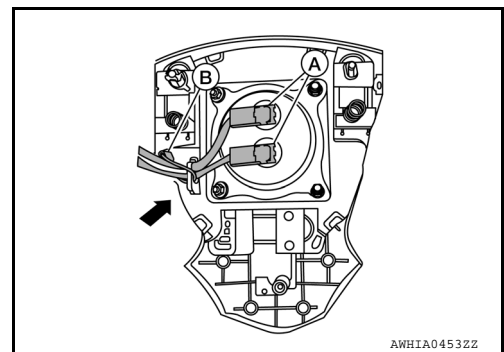

CAUTION:

A
B
C
D
E
F
G
SR
I
J
K
L
M
N
O
P

DRIVER AIR BAG MODULE

< REMOVAL AND INSTALLATION >

- For removing/installing the driver air bag module harness connector, insert a thin screwdriver wrapped in tape into the notch, then lift the lock and remove the harness connector as shown.
- Install the harness connector with the lock raised, and push the lock into the connector as shown.
- After installing the connector, check that the lock is pushed in securely.

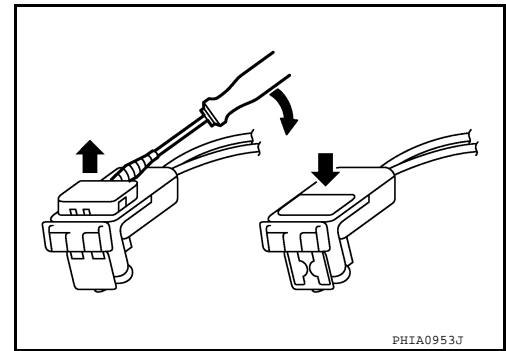

5. Remove the driver air bag module.

CAUTION:

- Always place the driver air bag module with pad side facing upward.
- ⇐: Upward

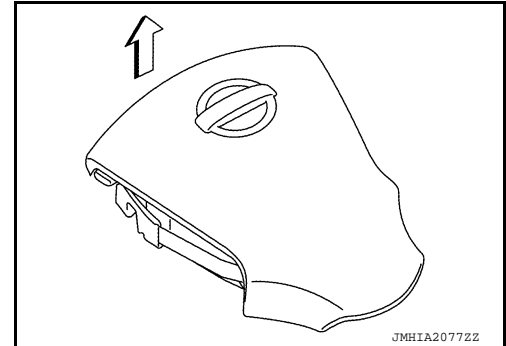

- Replace the driver air bag module if it has been dropped or sustained an impact.
- Do not strike the driver air bag module.



- Do not insert any foreign objects (screwdriver, etc.) into the driver air bag module.
- Do not disassemble the driver air bag module.
- Do not expose the driver air bag module to temperatures exceeding 90°C (194°F).
- Do not allow oil, grease, detergent or water to come in contact with the driver air bag module.

INSTALLATION

1. Place the driver air bag module (1) near the steering wheel and connect the horn terminal connector (B). Then route the wire harness through the hook (←) of the driver air bag module (1) as shown.
2. Connect the driver air bag module harness connectors (A) and route the wire harness through the hook (←) of the driver air bag module (1) as shown.

NOTE:

- Make sure the driver air bag module has three horn springs (2, 3) and they are securely seated. The lower spring (3) is more stiff than the two upper springs (2).
- Dual stage driver air bag module shown.

CAUTION:

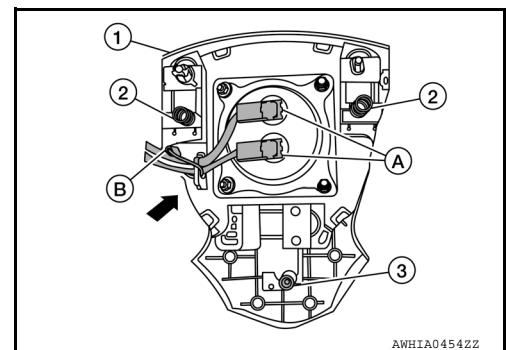

DRIVER AIR BAG MODULE

< REMOVAL AND INSTALLATION >

- For removing/installing the driver air bag module harness connector, insert a thin screwdriver wrapped in tape into the notch, then lift the lock and remove the harness connector as shown.
- Install the harness connector with the lock raised, and push the lock into the connector as shown.
- After installing the connector, check that the lock is pushed in securely.

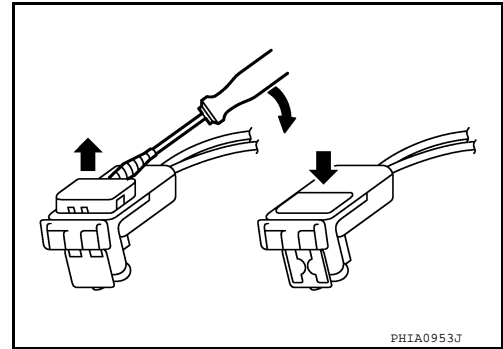

3. Insert the driver air bag module onto the steering wheel and push firmly to snap into place.
4. Check the horn function by pressing at the three locations (1, 2, 3) as shown.

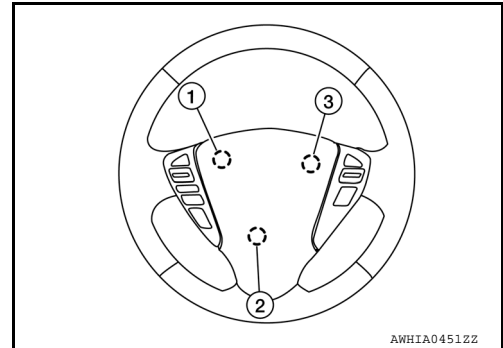

CAUTION:

- Be careful not to damage or pinch the harness while installing.
- After the work is completed, make sure no system malfunction is detected by air bag warning lamp.
- In case a malfunction is detected by the air bag warning lamp, reset by the self-diagnosis function and delete the memory using CONSULT.
- If a malfunction is still detected after the above operation, perform self-diagnosis to repair malfunctions. Refer to [SRC-17, "SRS Final Check"](#).

A
B
C
D
E
F
G
SR
I
J
K
L
M
N
O
P

SPIRAL CABLE

< REMOVAL AND INSTALLATION >

SPIRAL CABLE

Exploded View

INFOID:000000008894290

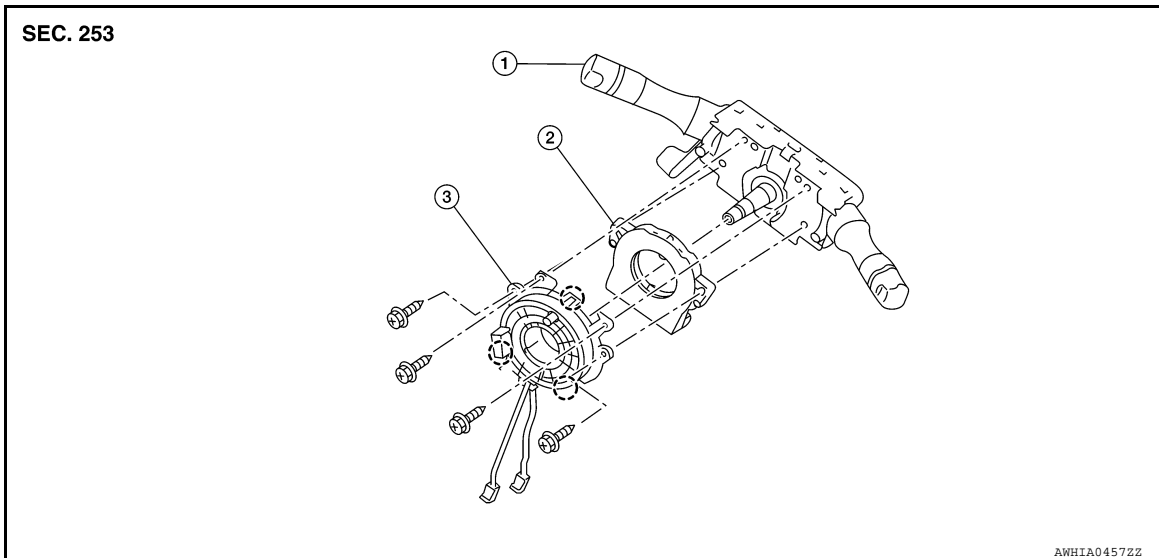

1. Combination switch

2. Steering angle sensor

3. Spiral cable

○ Pawl

Removal and Installation

INFOID:000000008832997

WARNING:

- Before servicing the SRS, turn ignition switch OFF, disconnect both battery terminals and wait at least three minutes.
- Do not use air tools or electric tools for servicing.

REMOVAL

1. Disconnect both the negative and positive battery terminals, then wait at least three minutes. Refer to [PG-50, "Removal and Installation \(Battery\)"](#).
2. Remove the steering wheel. Refer to [ST-11, "Removal and Installation"](#).
3. Remove the steering column lower cover and position steering column upper cover aside. Refer to [IP-16, "Removal and Installation"](#).
4. Disconnect the harness connector (A) from the spiral cable and the harness connector (B) from the steering angle sensor.

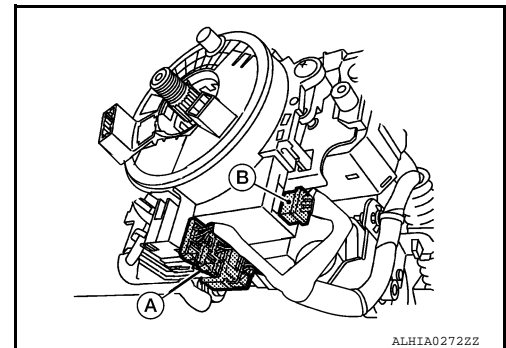

SPIRAL CABLE

< REMOVAL AND INSTALLATION >

5. Remove two screws (←) and the spiral cable and steering angle sensor assembly (1).

CAUTION:

Do not turn the spiral cable quickly or beyond the limit number of turns (approximately 2.5 turns from the neutral position), this may cause the cable to snap.

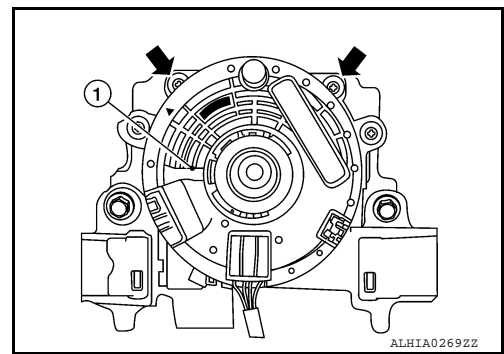

6. Separate the spiral cable (1) from the steering angle sensor (2) by removing two screws (A) and releasing three pawls (B).

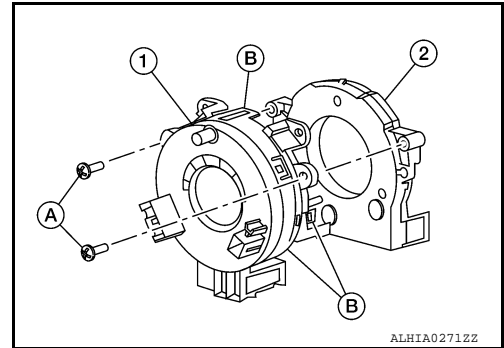

CAUTION:

- Do not strike or drop the spiral cable.
- Replace the spiral cable if it has been dropped or sustained an impact.
- Do not disassemble the spiral cable.
- Do not allow oil, grease, detergent or water to come in contact with the spiral cable.



INSTALLATION

Installation is in the reverse order of removal.

- The turn signal lever must be in the neutral position for spiral cable installation.

A
B
C
D
E
F
G
SR
I
J
K
L
M
N
O
P

SPIRAL CABLE

< REMOVAL AND INSTALLATION >

- Set the spiral cable (1) neutral position by carefully turning the spiral cable (1) clockwise to the end position. Turn the spiral cable (1) counterclockwise 2.5 turns stopping when the locating pin (C) is at the top most position, the triangles (A) are pointing at each other as shown and the clear window (B) appears white.

NOTE:

If a service part is installed, the neutral position is already set with a stopper clip in place and should not be adjusted after the stopper clip is removed. Make sure the stopper is removed before installing the steering wheel (2).

- During steering wheel (2) installation, make sure the locating pin hole (D) is aligned with the locating pin (C) of the spiral cable (1).
- Perform the neutral position adjustment for the steering angle sensor. Refer to [BRC-54, "Work Procedure"](#).

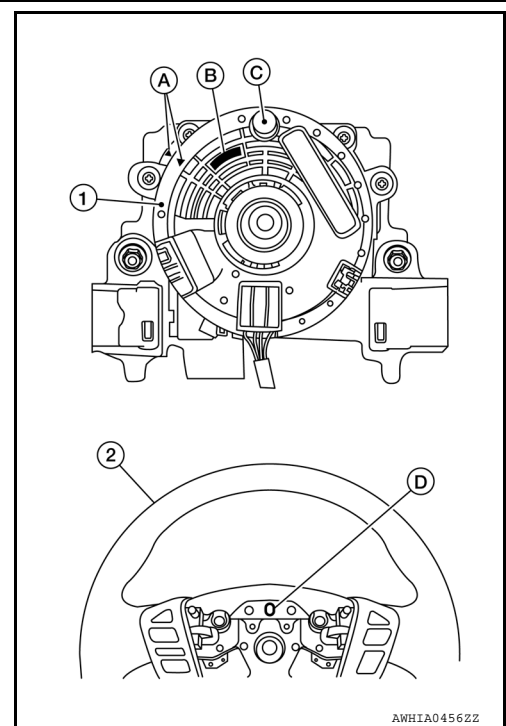

CAUTION:

- The spiral cable may snap during steering operation if the spiral cable is installed in an improper position.
- Do not overturn the spiral cable or go beyond the maximum number of turns allowed. This will cause the cable to snap.
- The turn signal lever must be in the neutral position for spiral cable installation.
- Do not apply lubricant to the spiral cable.
- Do not allow oil, grease, detergent or water to come in contact with the spiral cable.
- After the work is completed, check that no system malfunction is detected by air bag warning lamp.
- If a malfunction is detected by the air bag warning lamp after repair or replacement of the malfunctioning parts, perform the SRS final check. Refer to [SRC-17, "SRS Final Check"](#).

FRONT PASSENGER AIR BAG MODULE

< REMOVAL AND INSTALLATION >

FRONT PASSENGER AIR BAG MODULE

Exploded View

INFOID:000000008832998

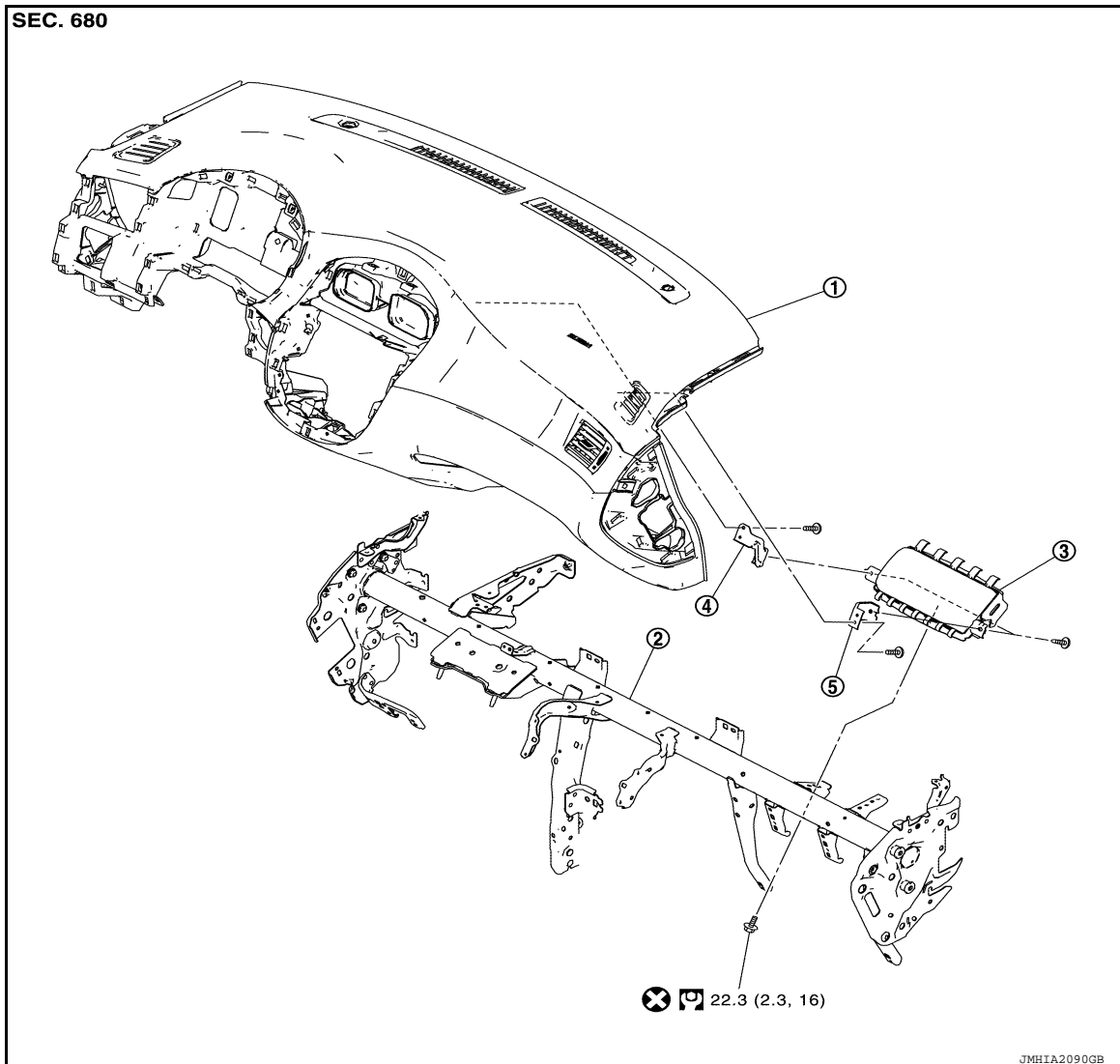

- | | | |
|--|--|-----------------------------------|
| 1. Instrument panel assembly | 2. Steering member assembly | 3. Front passenger air bag module |
| 4. Front passenger air bag module bracket (LH) | 5. Front passenger air bag module bracket (RH) | |

Removal and Installation

INFOID:000000008832999

WARNING:

- Before servicing the SRS, turn ignition switch OFF, disconnect both battery terminals and wait at least three minutes.
- Always work from the side of air bag module. Do not work in front of it.
- Do not use air tools or electric tools for servicing.

REMOVAL

1. Disconnect both the negative and positive battery terminals, then wait at least three minutes. Refer to [PG-50, "Removal and Installation \(Battery\)"](#).
2. Remove the instrument panel assembly. Refer to [IP-14, "Removal and Installation"](#).

FRONT PASSENGER AIR BAG MODULE

< REMOVAL AND INSTALLATION >

3. Remove the screws (A) from the front passenger air bag module brackets (RH) (1) and (LH) (2).

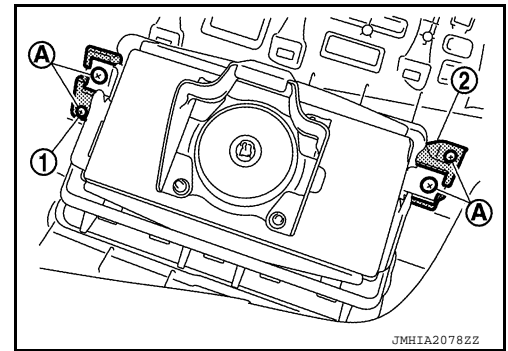

4. Pull back instrument panel grid and disengage the front passenger air bag module as shown.
5. Remove the front passenger air bag module from the instrument panel assembly.

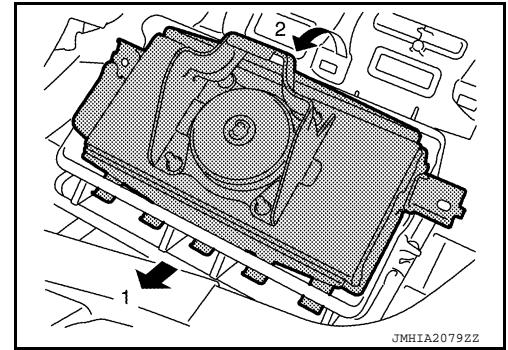

CAUTION:

- Always place the front passenger air bag module with the pad side facing upward as shown.
⇐: Upward

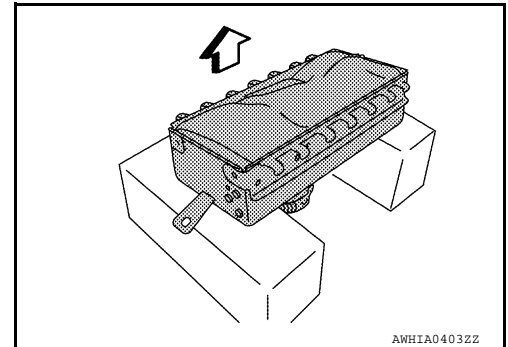

- Replace the front passenger air bag module if it has been dropped or sustained an impact.
- Do not strike the front passenger air bag module.



- Do not insert any foreign objects (screwdriver, etc.) into the front passenger air bag module.
- Do not disassemble the front passenger air bag module.
- Do not expose the front passenger air bag module to temperatures exceeding 90°C (194°F).
- Do not allow oil, grease, detergent, or water to come in contact with the front passenger air bag module.

INSTALLATION

Installation is in the reverse order of removal.

CAUTION:

- Do not reuse the front passenger air bag module bolts.

FRONT PASSENGER AIR BAG MODULE

< REMOVAL AND INSTALLATION >

- Do not damage the front passenger air bag module harness during installation.
- After installation is complete, check that no system malfunction is detected causing the air bag warning lamp to illuminate.
- If a malfunction is indicated by the air bag warning lamp after repair or replacement of the malfunctioning parts, perform the SRS final check. Refer to [SRC-17, "SRS Final Check"](#).

A

B

C

D

E

F

G

SR

I

J

K

L

M

N

O

P

SIDE CURTAIN AIR BAG MODULE

< REMOVAL AND INSTALLATION >

SIDE CURTAIN AIR BAG MODULE

Exploded View

INFOID:000000008833001

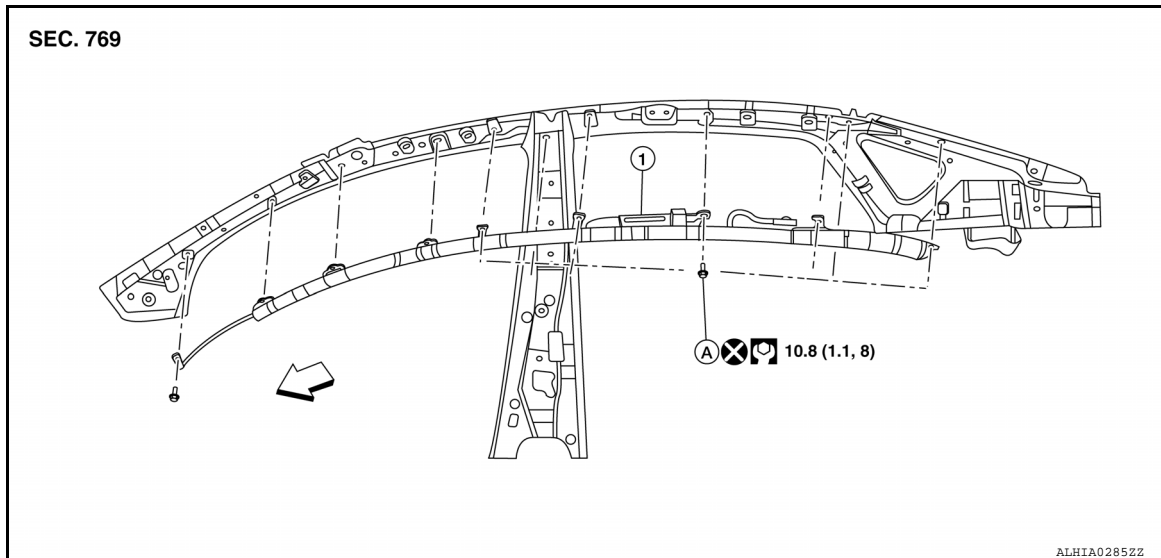

1. Side curtain air bag module

A. Side curtain air bag module bolt

← Front

NOTE:

RH side shown; LH side similar.

Removal and Installation

INFOID:000000008833001

WARNING:

- Before servicing the SRS, turn ignition switch OFF, disconnect both battery terminals and wait at least three minutes.
- Always work from the side of air bag module. Do not work in front of it.
- Do not use air tools or electric tools for servicing.

REMOVAL

1. Disconnect the negative and positive battery terminals, then wait at least three minutes. Refer to [PG-50. "Removal and Installation \(Battery\)"](#).
2. Lower the headlining. Refer to [INT-40. "Removal and Installation"](#).

NOTE:

It is not necessary to remove the headlining from the vehicle.

3. Disconnect the harness connector (A) from the side curtain air bag module (1) and unclip the harness from bracket (←).

← Front

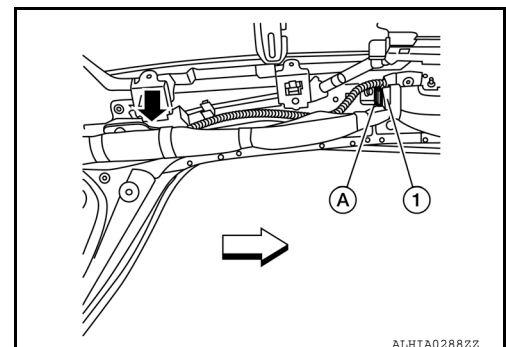

CAUTION:

SIDE CURTAIN AIR BAG MODULE

< REMOVAL AND INSTALLATION >

- For removing/installing the side curtain air bag module harness connector, insert a thin screwdriver wrapped in tape into the notch, lift the lock and remove the harness connector as shown.
- Install the harness connector with the lock raised, and push the lock into the harness connector as shown.
- After installing the harness connector, check that the lock is pushed in securely.

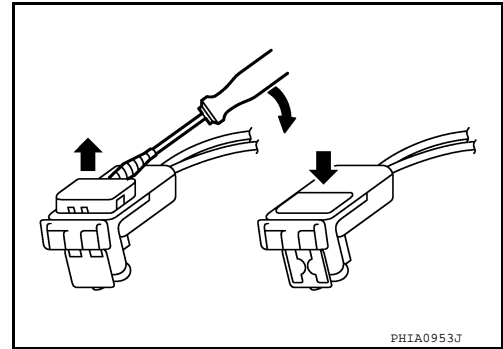

4. Disengage metal clips on the front of roof panel using suitable tool.
CAUTION:
Do not deform metal clip.
5. Remove the side curtain air bag module bolts, then remove the side curtain air bag module.
CAUTION:
 - Replace the side curtain air bag module if it has been dropped or sustained an impact.
 - Do not strike the side curtain air bag module.
 - Do not insert any foreign objects (screwdriver, etc.) into the side curtain air bag module.
 - Do not disassemble the side curtain air bag module.
 - Do not expose the side curtain air bag module to temperatures exceeding 93°C (200°F).
 - Do not allow oil, grease, detergent or water to come in contact with the side curtain air bag module.

INSTALLATION

Installation is in the reverse order of removal.

WARNING:

- When installing the side curtain air bag module make sure it is not twisted between attachment brackets.
- After installation check that the blue or red air bag positioning line is shown along the front side of the side curtain air bag module to confirm it is not twisted.

CAUTION:

- Route the side curtain air bag module front tether (1) and attach the double stick tape (A) as shown.

←: Front

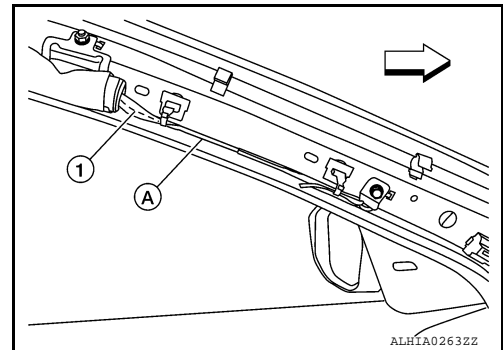

- Do not damage the harness while installing the side curtain air bag module.
- Insert metal clips into front roof until a locking sound is heard. Check that they are fully locked to the vehicle body.
- After installation is complete, check that no system malfunction is detected causing the air bag warning lamp to illuminate.
- If a malfunction is indicated by the air bag warning lamp after repair or replacement of the malfunctioning parts, perform the SRS final check. Refer to [SRC-17, "SRS Final Check"](#).

SIDE AIR BAG MODULE

< REMOVAL AND INSTALLATION >

SIDE AIR BAG MODULE

Removal and Installation

INFOID:000000008833002

The side air bag module is part of the front seatback. For removal and installation of the side air bag module, refer to [SE-18, "DRIVER SIDE : Removal and Installation - Seat Assembly"](#) (driver front seat) or [SE-20, "PASSENGER SIDE : Removal and Installation - Seat Assembly"](#) (passenger front seat).

CAUTION:

- Always work from the side or back of the front seatback assembly, do not work in front of seat.
- Do not use air tools or electric tools for servicing the front seat assembly.
- Do not insert any objects into the side air bag module.
- Do not attempt to disassemble the side air bag module.
- Do not expose the side air bag module to temperatures exceeding 93°C (200°F).
- Do not expose the side air bag module to any oil, grease, detergent or water.

NOTE:

- If the vehicle has been involved in a collision and the side air bag module has deployed, the seatback pad and trim must be replaced.
- For side air bag module removal and installation, seatback trim and seatback pad must be removed.

CRASH ZONE SENSOR

< REMOVAL AND INSTALLATION >

CRASH ZONE SENSOR

Exploded View

INFOID:000000008925903

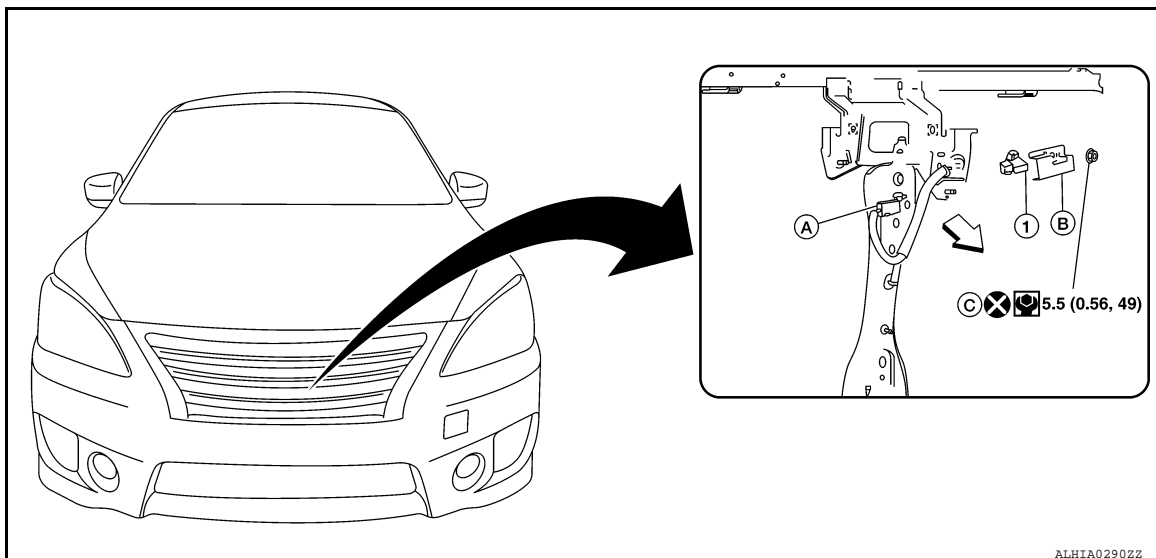

1. Crash zone sensor A. Crash zone sensor harness connector B. Crash zone sensor bracket
C. Crash zone sensor nut ⇐ Front

Removal and Installation

INFOID:000000008833003

REMOVAL

WARNING:

- Before servicing the SRS, turn ignition switch OFF, disconnect both battery terminals and wait at least three minutes.
- Do not use air tools or electric tools for servicing.

1. Disconnect the negative and positive battery terminals, then wait at least three minutes. Refer to [PG-50, "Removal and Installation \(Battery\)"](#).
2. Remove the upper core support cover.
3. Disconnect the harness connector from the crash zone sensor.
4. Remove the nut and the crash zone sensor.

CAUTION:

- Replace the crash zone sensor if it has been dropped or sustained an impact.
- Do not strike the crash zone sensor.
- Replace the crash zone sensor if either the driver air bag or the front passenger air bag has been deployed.

INSTALLATION

Installation is in the reverse order of removal.

CAUTION:

- Do not reuse the crash zone sensor nut.
- Do not damage the harness connector during installation.
- After installation is complete, check that no system malfunction is detected causing the air bag warning lamp to illuminate.
- If a malfunction is indicated by the air bag warning lamp after repair or replacement of the malfunctioning parts, perform the SRS final check. Refer to [SRC-17, "SRS Final Check"](#).

A
B
C
D
E
F
G
SR

SIDE AIR BAG (SATELLITE) SENSOR

< REMOVAL AND INSTALLATION >

SIDE AIR BAG (SATELLITE) SENSOR

Exploded View

INFOID:000000008833004

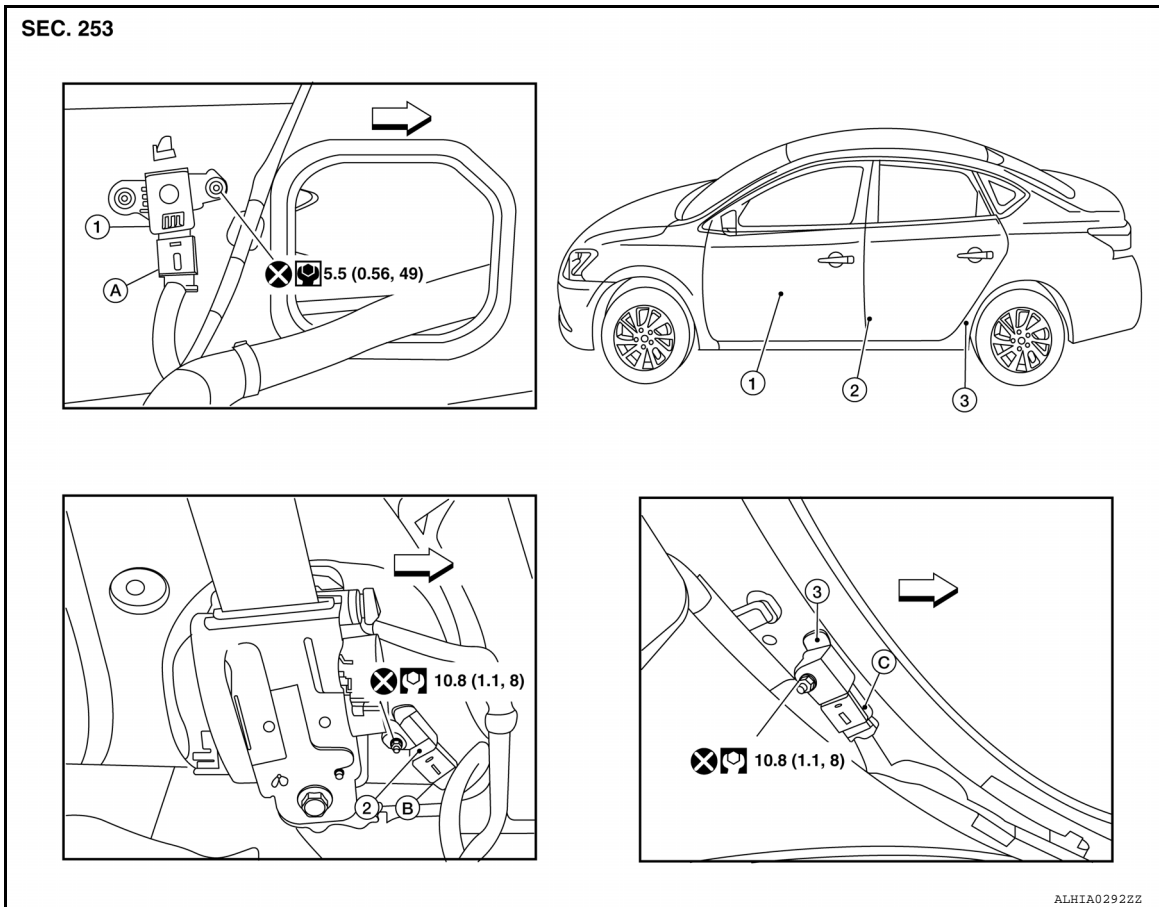

1. Front door (satellite) sensor 2. Front side air bag (satellite) sensor 3. Rear side air bag (satellite) sensor
A. Front door (satellite) sensor harness connector B. Front side air bag (satellite) sensor harness connector C. Rear side air bag (satellite) sensor harness connector

← Front

Removal and Installation

INFOID:000000008833005

WARNING:

- Before servicing the SRS, turn ignition switch OFF, disconnect both battery terminals and wait at least three minutes.
- Do not use air tools or electric tools for servicing.

FRONT DOOR (SATELLITE) SENSOR (LH/RH)

Removal

1. Disconnect both the negative and positive battery terminals, then wait at least three minutes. Refer to [PG-50, "Removal and Installation \(Battery\)"](#).
2. Remove front door finisher. Refer to [INT-15, "Removal and Installation"](#).
3. Position aside the vapor barrier.
4. Disconnect the harness connector from the front door (satellite) sensor.
5. Remove the nuts and the front door (satellite) sensor.

CAUTION:

- Do not reuse the front door satellite sensor nuts.
- Replace the front door satellite sensor if it has been dropped or sustained an impact.

SIDE AIR BAG (SATELLITE) SENSOR

< REMOVAL AND INSTALLATION >

- Do not strike the front door satellite sensor.

Installation

Installation is in the reverse order of removal.

CAUTION:

- Do not reuse the front door (satellite) sensor bolts.
- Do not damage the harness connector or harness.
- After installation is complete, check that no system malfunction is detected causing the air bag warning lamp to illuminate.
- If a malfunction is indicated by the air bag warning lamp after repair or replacement of the malfunctioning parts, perform the SRS final check. Refer to [SRC-17, "SRS Final Check"](#).

FRONT SIDE AIR BAG (SATELLITE) SENSOR (LH/RH)

Removal

1. Disconnect both the negative and positive battery terminals, then wait at least three minutes. Refer to [PG-50, "Removal and Installation \(Battery\)"](#).
2. Remove the front seat belt retractor. Refer to [SB-8, "Removal and Installation"](#).
3. Disconnect the harness connector from the front side air bag (satellite) sensor.
4. Remove the nut and the front side air bag (satellite) sensor.

CAUTION:

- Do not reuse the front side air bag (satellite) sensor nut.
- Replace the front side air bag (satellite) sensor if it has been dropped or sustained an impact.
- Do not strike the front side air bag (satellite) sensor.

Installation

Installation is in the reverse order of removal.

CAUTION:

- Do not reuse the front side air bag (satellite) sensor nut.
- Do not damage the harness connector or harness.
- After installation is complete, check that no system malfunction is detected causing the air bag warning lamp to illuminate.
- If a malfunction is indicated by the air bag warning lamp after repair or replacement of the malfunctioning parts, perform the SRS final check. Refer to [SRC-17, "SRS Final Check"](#).

REAR SIDE AIR BAG (SATELLITE) SENSOR (LH/RH)

Removal

1. Disconnect both the negative and positive battery terminals, then wait at least three minutes. Refer to [PG-50, "Removal and Installation \(Battery\)"](#).
2. Remove the rear kicking plate inner. Refer to [INT-24, "KICKING PLATE INNER : Removal and Installation"](#).
3. Disconnect the harness connector from the rear side air bag (satellite) sensor.
4. Remove the nut and the rear side air bag (satellite) sensor.

CAUTION:

- Do not reuse the rear side air bag (satellite) sensor nut.
- Replace the rear side air bag (satellite) sensor if it has been dropped or sustained an impact.
- Do not strike the rear side air bag (satellite) sensor.

Installation

Installation is in the reverse order of removal.

CAUTION:

- Do not reuse the rear side air bag (satellite) sensor nut.
- Do not damage the harness connector or harness.
- After installation is complete, check that no system malfunction is detected causing the air bag warning lamp to illuminate.
- If a malfunction is indicated by the air bag warning lamp after repair or replacement of the malfunctioning parts, perform the SRS final check. Refer to [SRC-17, "SRS Final Check"](#).

A
B
C
D
E
F
G
SR
I
J
K
L
M
N
O
P

DIAGNOSIS SENSOR UNIT

< REMOVAL AND INSTALLATION >

DIAGNOSIS SENSOR UNIT

Exploded View

INFOID:000000008925904

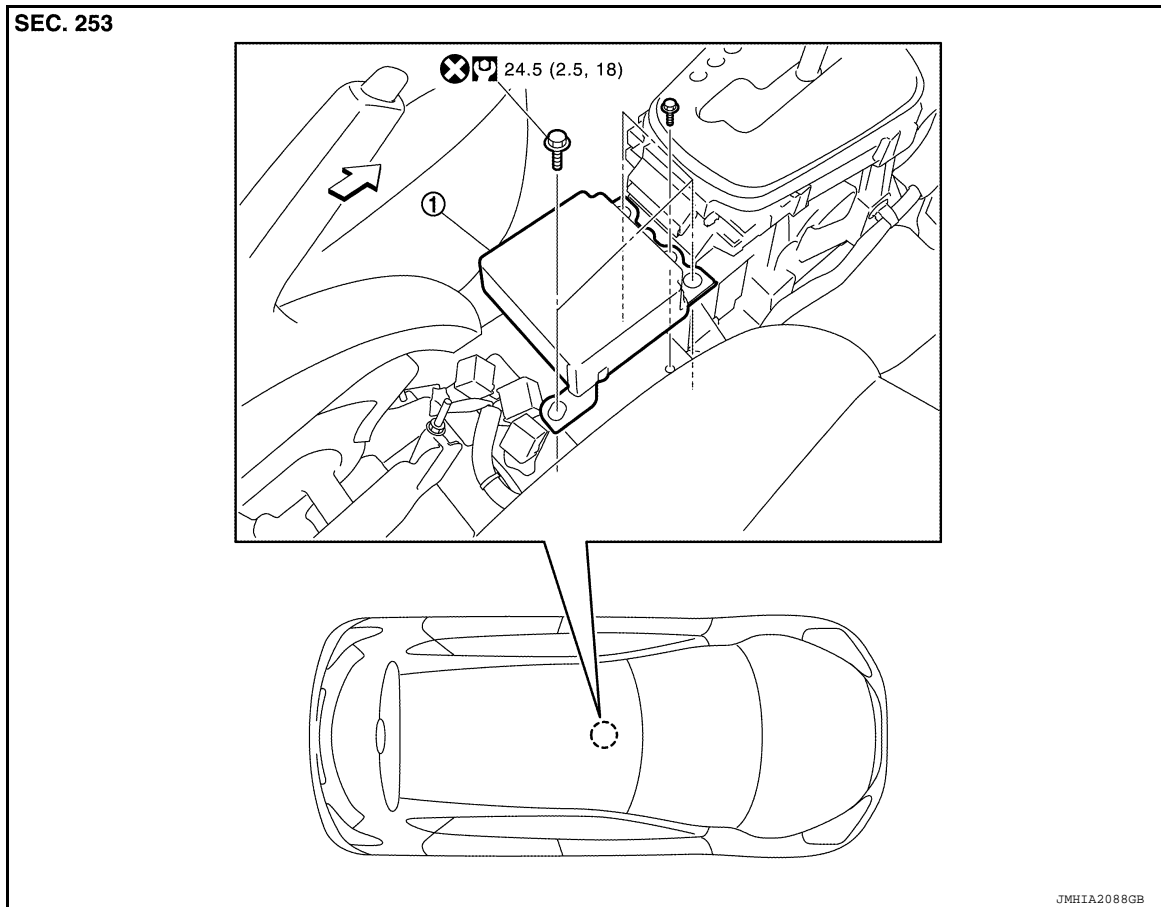

1. Air bag diagnosis sensor unit ← Front

Removal and Installation

INFOID:000000008833006

REMOVAL

WARNING:

- Before servicing the SRS, turn ignition switch OFF, disconnect both battery terminals and wait at least three minutes.
 - Before disconnecting the air bag diagnosis sensor unit harness connectors, be sure to disconnect each harness connector of the front shoulder belt pre-tensioners to prevent accidental air bag deployment by static electricity and seat belt pre-tensioner operation.
 - Do not use the air tools or electric tools for servicing.
 - When replacing the air bag diagnosis sensor unit, always check with the parts department for the latest parts information. Installing an incorrect air bag diagnosis sensor unit may or may not cause the air bag warning lamp to illuminate and may cause incorrect deployment of the supplemental air bags and seat belt pre-tensioners in a collision resulting in serious personal injury or death.
1. Always check the air bag diagnosis sensor unit ECU discriminated number (identification number) or part number using CONSULT.
 2. Disconnect both the negative and positive battery terminals, then wait at least three minutes. Refer to [PG-50. "Removal and Installation \(Battery\)"](#).
 3. Disconnect the harness connectors for the front shoulder belt pre-tensioners LH/RH. Refer to [SR-31. "Removal and Installation"](#).
 4. Remove the center console assembly. Refer to [IP-17. "Removal and Installation"](#).

DIAGNOSIS SENSOR UNIT

< REMOVAL AND INSTALLATION >

5. Disconnect the harness connectors (A) from air bag diagnosis sensor unit.
6. Remove the air bag diagnosis sensor unit shield bolt and air bag diagnosis sensor unit bolts (B), then remove the air bag diagnosis sensor unit.

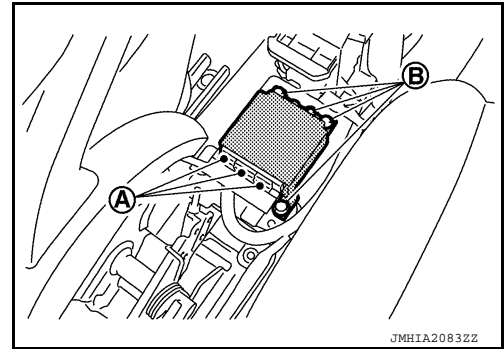

CAUTION:

- Do not reuse the air bag diagnosis sensor unit bolts.
- Replace the air bag diagnosis sensor unit if it has been dropped or sustained an impact.
- Do not strike the air bag diagnosis sensor unit.
- Replace the air bag diagnosis sensor unit if any SRS air bag has been deployed or if any front seat belt pre-tensioner has been deployed.

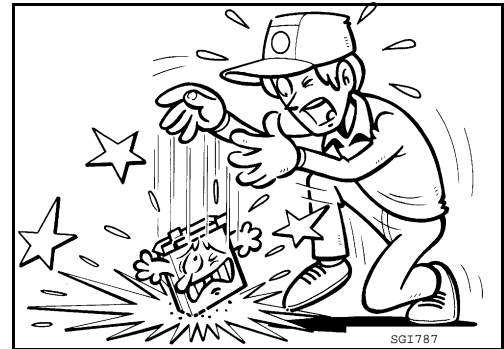

INSTALLATION

Installation is in the reverse order of removal.

CAUTION:

- Do not reuse the air bag diagnosis sensor unit bolts.
- The air bag diagnosis sensor unit must always be installed with the label arrow mark "←" pointing toward the front of the vehicle for proper operation.
- Do not damage the air bag diagnosis sensor unit harness connectors during installation.
- Be careful not to damage the diagnosis sensor unit harness.
- After installation is complete, check that no system malfunction is detected causing the air bag warning lamp to illuminate.
- If a malfunction is indicated by the air bag warning lamp after repair or replacement of the malfunctioning parts, perform the SRS final check. Refer to [SRC-17, "SRS Final Check"](#).
- After replacing the air bag diagnosis sensor unit, confirm using CONSULT that the ECU discriminated number (identification number) or part number of the new replacement air bag diagnosis sensor unit matches the ECU discriminated number (identification number) or part number of the replaced (old) air bag diagnosis sensor unit.

NOTE:

If the ECU discriminated number or part number of the new replacement air bag diagnosis sensor unit differs from the ECU discriminated number or part number of the replaced air bag diagnosis sensor unit, reconfirm the parts information and verify that the correct air bag diagnosis sensor unit was installed.

A
B
C
D
E
F
G
SR
I
J
K
L
M
N
O
P

OCCUPANT CLASSIFICATION SYSTEM

< REMOVAL AND INSTALLATION >

OCCUPANT CLASSIFICATION SYSTEM

Removal and Installation

INFOID:000000008833007

OCCUPANT CLASSIFICATION SYSTEM CONTROL UNIT

The occupant classification system control unit is serviced with the front passenger seat frame assembly. For disassembly and assembly of the front passenger seat frame assembly, refer to [SE-36, "PASSENGER SIDE : Disassembly and Assembly"](#).

OCCUPANT CLASSIFICATION SYSTEM SENSORS

The occupant classification system sensors are part of the front passenger seat frame assembly. For disassembly and assembly of the front passenger seat frame assembly, refer to [SE-36, "PASSENGER SIDE : Disassembly and Assembly"](#).

SEAT BELT PRE-TENSIONER

< REMOVAL AND INSTALLATION >

SEAT BELT PRE-TENSIONER

Removal and Installation

INFOID:000000008833008

The front seat belt pre-tensioner is part of the front seat belt retractor. For removal and installation of the front seat belt retractor, refer to [SB-8. "Removal and Installation"](#).

- A
- B
- C
- D
- E
- F
- G
- SR
- I
- J
- K
- L
- M
- N
- O
- P

FRONT SEAT BELT BUCKLE SWITCH

< REMOVAL AND INSTALLATION >

FRONT SEAT BELT BUCKLE SWITCH

Removal and Installation

INFOID:000000008833009

The front seat belt buckle switch is part of the front seat belt buckle. For removal and installation of the front seat belt buckle, refer to [SB-8, "Removal and Installation"](#).

PASSENGER AIR BAG INDICATOR

< REMOVAL AND INSTALLATION >

PASSENGER AIR BAG INDICATOR

Removal and Installation

INFOID:000000008833010

The passenger air bag indicator is part of the center ventilator grill assembly. For removal and installation of the center ventilator grill assembly, refer to [IP-20. "Removal and Installation - Cluster Lid C"](#).

A
B
C
D
E
F
G
SR
I
J
K
L
M
N
O
P