

SECTION **SB**
SEAT BELT

A
B
C
D
E
F
G
SB
I
J
K
L
M
N
O
P

CONTENTS

PRECAUTION	2	REMOVAL AND INSTALLATION	8
PRECAUTIONS	2	FRONT SEAT BELT	8
Precaution for Supplemental Restraint System (SRS) "AIR BAG" and "SEAT BELT PRE-TENSIONER"	2	Exploded View	8
Precaution for Seat Belt Service	2	Removal and Installation	8
Precaution for Work	2	REAR SEAT BELT	11
PREPARATION	4	Exploded View - Seat Belt Retractor	11
PREPARATION	4	Removal and Installation - Seat Belt Retractor	11
Special Service Tool	4	Exploded View - Seat Belt Buckle	12
BASIC INSPECTION	5	Removal and Installation - Seat Belt Buckle	12
COMPONENT INSPECTION	5	LATCH SYSTEM FOR CHILDREN	13
Inspection	5	Exploded View	13
		Removal and Installation	13
		TOP TETHER STRAP CHILD RESTRAINT	14
		Removal and Installation	14

PRECAUTIONS

< PRECAUTION >

PRECAUTION

PRECAUTIONS

Precaution for Supplemental Restraint System (SRS) "AIR BAG" and "SEAT BELT PRE-TENSIONER"

INFOID:000000010296570

The Supplemental Restraint System such as "AIR BAG" and "SEAT BELT PRE-TENSIONER", used along with a front seat belt, helps to reduce the risk or severity of injury to the driver and front passenger for certain types of collision. Information necessary to service the system safely is included in the SR and SB section of this Service Manual.

WARNING:

- To avoid rendering the SRS inoperative, which could increase the risk of personal injury or death in the event of a collision which would result in air bag inflation, all maintenance must be performed by an authorized NISSAN/INFINITI dealer.
- Improper maintenance, including incorrect removal and installation of the SRS, can lead to personal injury caused by unintentional activation of the system. For removal of Spiral Cable and Air Bag Module, see the SR section.
- Do not use electrical test equipment on any circuit related to the SRS unless instructed to in this Service Manual. SRS wiring harnesses can be identified by yellow and/or orange harnesses or harness connectors.

PRECAUTIONS WHEN USING POWER TOOLS (AIR OR ELECTRIC) AND HAMMERS

WARNING:

- When working near the Airbag Diagnosis Sensor Unit or other Airbag System sensors with the Ignition ON or engine running, DO NOT use air or electric power tools or strike near the sensor(s) with a hammer. Heavy vibration could activate the sensor(s) and deploy the air bag(s), possibly causing serious injury.
- When using air or electric power tools or hammers, always switch the Ignition OFF, disconnect the battery and wait at least three minutes before performing any service.

Precaution for Seat Belt Service

INFOID:000000009756324

CAUTION:

- Before removing the seat belt pre-tensioner assembly, turn the ignition switch OFF, disconnect both battery terminals and wait at least three minutes. For approximately three minutes after the battery terminals have been removed, it is still possible for the air bag and seat belt pre-tensioner to deploy. Therefore, do not attempt work on any SRS connectors or wires until at least three minutes have passed.
- After replacing or reinstalling seat belt pre-tensioner assembly or reconnecting seat belt pre-tensioner assembly connector, make sure entire SRS operates properly. Refer to [SRC-41. "ADDITIONAL SERVICE WHEN REPLACING CONTROL UNIT : Special Repair Requirement"](#).
- Do not disassemble buckle or seat belt assembly.
- Replace anchor bolts if they are deformed or worn out.
- Do not oil tongue or buckle.
- If any component of seat belt assembly is questionable, do not repair. Replace the whole seat belt assembly.
- If webbing is cut, frayed or damaged, replace seat belt assembly.
- When replacing seat belt assembly, use a genuine NISSAN seat belt assembly.

Precaution for Work

INFOID:000000009756325

- When removing or disassembling each component, be careful not to damage or deform it. If a component may be subject to interference, be sure to protect it with a shop cloth.
- When removing (disengaging) components with a screwdriver or similar tool, be sure to wrap the component with a shop cloth or vinyl tape to protect it.
- Protect the removed parts with a shop cloth and prevent them from being dropped.
- Replace a deformed or damaged clip.
- If a part is specified as a non-reusable part, always replace it with a new one.
- Be sure to tighten bolts and nuts securely to the specified torque.
- After installation is complete, be sure to check that each part works properly.

PRECAUTIONS

< PRECAUTION >

- Follow the steps below to clean components:
- Water soluble dirt:
 - Dip a soft cloth into lukewarm water, wring the water out of the cloth and wipe the dirty area.
 - Then rub with a soft, dry cloth.
- Oily dirt:
 - Dip a soft cloth into lukewarm water with mild detergent (concentration: within 2 to 3%) and wipe the dirty area.
 - Then dip a cloth into fresh water, wring the water out of the cloth and wipe the detergent off.
 - Then rub with a soft, dry cloth.
- Do not use organic solvent such as thinner, benzene, alcohol or gasoline.
- For genuine leather seats, use a genuine leather seat cleaner.

A

B

C

D

E

F

G

SB

I

J

K

L

M

N

O

P

PREPARATION

< PREPARATION >

PREPARATION

PREPARATION

Special Service Tool

INFOID:000000009756326

The actual shape of the tools may differ from those of illustrated here.

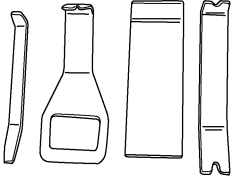
Tool number (TechMate No.) Tool name	Description
— (J-46534) Trim Tool Set  AWJIA0483ZZ	Removing trim components

COMPONENT INSPECTION

< BASIC INSPECTION >

BASIC INSPECTION

COMPONENT INSPECTION

Inspection

INFOID:000000009756327

AFTER A COLLISION

WARNING:

Inspect all seat belt assemblies including retractors and attaching hardware after any collision. NISSAN/INFINITI recommends that all seat belt assemblies in use during a collision be replaced unless the collision was minor and the belts show no damage and continue to operate properly. Failure to do so could result in serious personal injury in an accident. Seat belt assemblies not in use during a collision should also be replaced if either damage or improper operation is noted. Seat belt pretensioners should be replaced even if the seat belts are not in use during a frontal collision in which the air bags are deployed.

Replace any seat belt assembly (including anchor bolts) if:

- The seat belt was in use at the time of a collision (except for minor collisions and the belts, retractors and buckles show no damage and continue to operate properly).
- The seat belt was damaged in an accident (i.e. torn webbing, bent retractor or guide, etc.).
- The seat belt attaching point is damaged in an accident. Inspect the seat belt attaching area for damage or distortion and repair if necessary before installing a new seat belt assembly.
- Anchor bolts are deformed or worn out.
- The seat belt pre-tensioner should be replaced even if the seat belts are not in use during the collision in which the air bags are deployed.

PRELIMINARY CHECKS

1. Check the seat belt warning lamp for proper operation per the following:
 - a. Turn ignition switch ON. The seat belt warning lamp should illuminate.
 - b. Fasten driver seat belt. The seat belt warning lamp should turn OFF.
 2. If the air bag warning lamp is blinking, perform self-diagnosis with CONSULT and air bag warning lamp. Refer to [SRC-16. "Trouble Diagnosis with CONSULT"](#).
 3. Check that the seat belt retractor, seat belt anchor and buckle bolts are tightened firmly.
 4. Check the shoulder seat belt guide and shoulder belt height adjuster for front seats. Check that guide swivels freely and that webbing lays flat and does not bind in guide. Check that height adjuster operates properly and holds securely.
 5. Check retractor operation:
 - a. Fully extend the seat belt webbing and check for twists, tears or other damage.
 - b. Allow the seat belt to retract. Check that webbing returns smoothly and completely into the retractor. If the seat belt does not return smoothly, wipe the inside of the loops with a clean paper cloth. Dirt build-up in the loops of the upper anchors can cause the seat belts to retract slowly.
 - c. Fasten the seat belt. Check that seat belt returns smoothly and completely to the retractor. If the webbing does not return smoothly, the cause may be an accumulation of dust or dirt. Use the "SEAT BELT TAPE SET" and perform the following steps.
 - d. Inspect the front seat belt D-ring anchor
 1. Pull the seat belt out to a length of 500 mm (19.69 in) or more.
 2. Hold the seat belt at the center pillar webbing opening with a clip or other device.
 3. Pass a thin wire through the D-ring anchor webbing opening. Hold both ends of the wire and pull it tightly while moving it up and down several times along the webbing opening surface to remove dirt stuck there.
 4. Any dirt that cannot be removed with the wire can be removed by cleaning the opening with a clean cloth.
 5. Apply tape at the point where the webbing contacts the D-ring anchor webbing opening.
NOTE:
Apply the tape so that there is no slack or wrinkling.
 6. Remove the clip holding the seat belt and check that the webbing returns smoothly.
6. Repeat steps above if necessary to check the other seat belts.

COMPONENT INSPECTION

< BASIC INSPECTION >

SEAT BELT RETRACTOR ON-VEHICLE CHECK

Emergency Locking Retractors (ELR) and Automatic Locking Retractors (ALR)

NOTE:

All seat belt retractors are Emergency Locking Retractors (ELR) type. In an emergency (sudden stop) the retractor will lock and prevent the webbing from extending any further. All 3-point type seat belt retractors except the driver seat belt also have an Automatic Locking Retractors (ALR) mode. The ALR mode (also called child restraint mode) is used when installing child seats. The ALR mode is activated when the seat belt is fully extended. When the webbing is then retracted partially, the ALR mode automatically locks the seat belt in a specific position so the webbing cannot be extended any further. To cancel the ALR mode, allow the seat belt to fully wind back into the retractor.

Check the seat belt retractors with the following test(s) to determine if a retractor assembly is operating properly.

ELR Function Stationary Check

Grasp the shoulder webbing and pull forward quickly. The retractor should lock and prevent the belt from extending further.

ALR Function Stationary Check

1. Pull out the entire length of seat belt from retractor until a click is heard.
2. Retract the webbing partially. A clicking noise should be heard as the webbing retracts, indicating that the retractor is in the Automatic Locking Retractors (ALR) mode.
3. Grasp the seat belt and try to pull out the retractor. The webbing must lock and not extend any further. If it does not operate normally, replace the retractor assembly.
4. Allow the entire length of the webbing to retract to cancel the automatic locking mode.

ELR Function Moving Check

WARNING:

Perform the following test in a safe, open area clear of other vehicles and obstructions (for example, a large, empty parking lot). Road surface must be paved and dry. Do not perform the following test on wet or gravel roads or on public streets and highways. This could result in an accident and serious personal injury. The driver and passenger must be prepared to brace themselves in the event that the retractor does not lock.

1. Fasten driver seat belt. Buckle a passenger into the seat for the belt that is to be tested.
2. Proceed to the designated safe area.
3. Drive the vehicle at approximately 16 km/h (10 mph). Notify any passengers of a pending sudden stop and the driver and passenger must be prepared to brace themselves in the event that the retractor does not lock. Apply brakes firmly and make a very hard stop.

During stopping, seat belts should lock and not be extended. If the seat belt retractor assembly does not lock, perform the retractor off-vehicle check.

FRONT SEAT BELT RETRACTOR OFF-VEHICLE CHECK

1. Remove the front seat belt retractor. Refer to [SB-8, "Removal and Installation"](#).
2. Slowly pull out webbing while tilting the seat belt retractor forward from the mounted position without twisting the seat belt retractor as shown.

A: The webbing can be pulled out if the retractor is tilted 15° degree or less.

B: The webbing can not be pulled out if the retractor is tilted 45° degrees or more.

NOTE:

A and B show tilting angles.

↔: Front

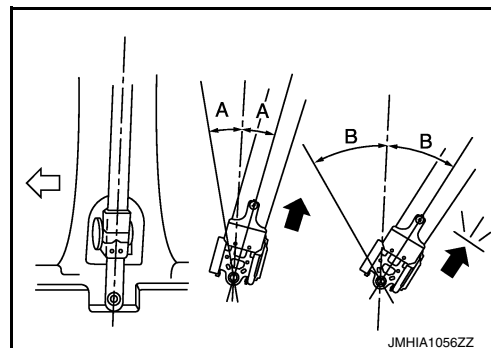

3. Replace the seat belt retractor if it does not operate within specifications.

REAR SEAT BELT RETRACTOR OFF-VEHICLE CHECK

COMPONENT INSPECTION

< BASIC INSPECTION >

1. Remove the rear seat belt retractor. Refer to [SB-11, "Removal and Installation - Seat Belt Retractor"](#).
2. Slowly pull out webbing while tilting the seat belt retractor forward from the mounted position without twisting the seat belt retractor as shown.

A: The webbing can be pulled out if the retractor is tilted 15° degree or less.

B: The webbing can not be pulled out if the retractor is tilted 35° degrees or more.

NOTE:

A and B show tilting angles.

⇐: Front

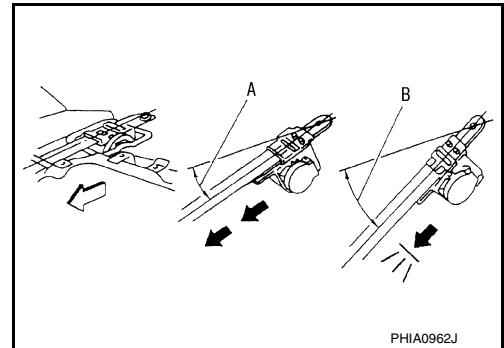

3. Replace the seat belt retractor if it does not operate within specifications.

A
B
C
D
E
F
G
I
J
K
L
M
N
O
P

SB

FRONT SEAT BELT

< REMOVAL AND INSTALLATION >

REMOVAL AND INSTALLATION

FRONT SEAT BELT

Exploded View

INFOID:000000009756328

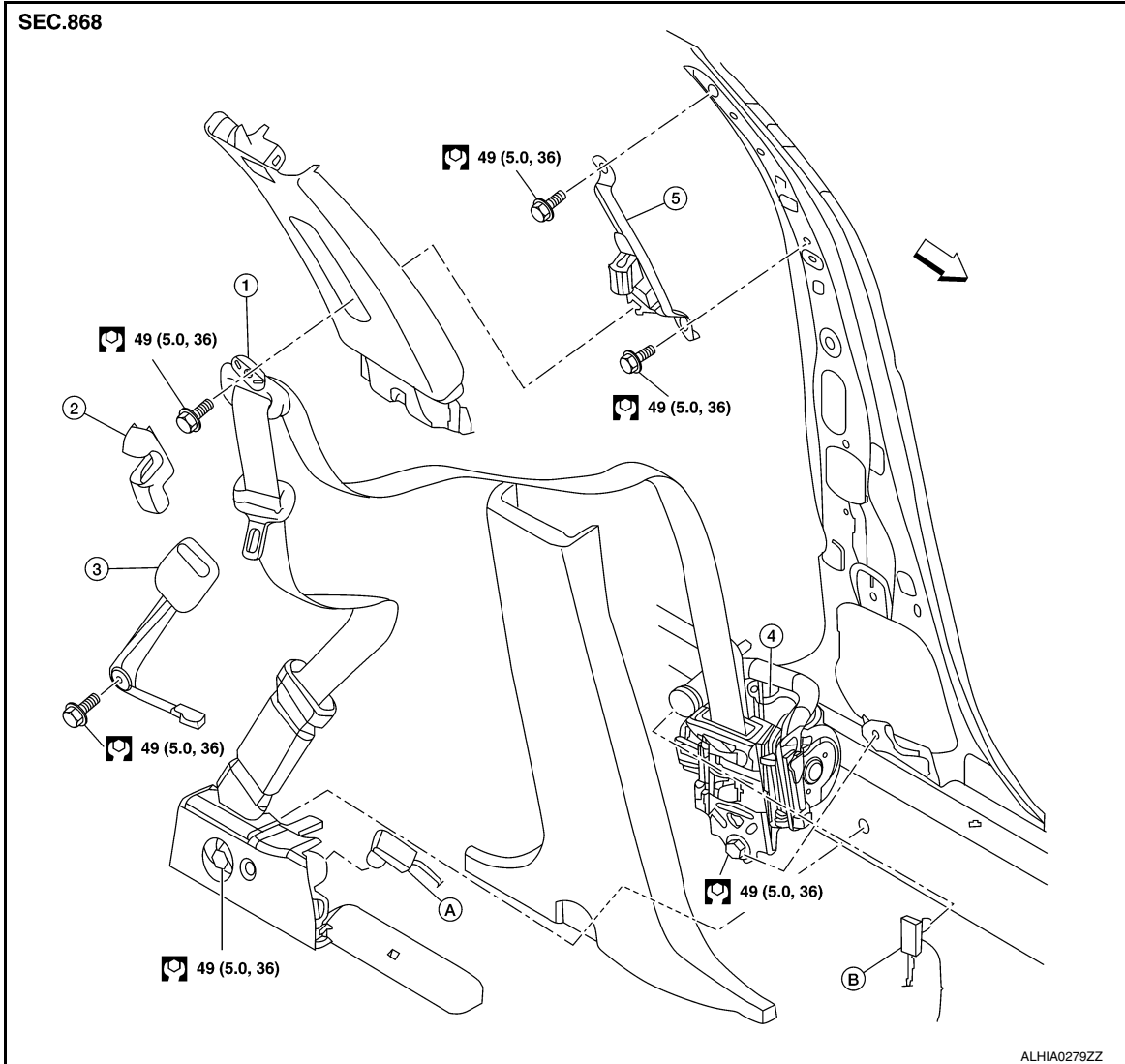

- | | | |
|--|------------------------------------|---|
| 1. D-ring anchor | 2. Seat belt height adjuster cover | 3. Seat belt buckle |
| 4. Seat belt retractor | 5. Seat belt height adjuster | A. Lap belt pre-tensioner harness connector |
| B. Shoulder belt pre-tensioner harness connector | ← Front | |

NOTE:

LH side shown; RH side similar.

Removal and Installation

INFOID:000000009756329

SEAT BELT RETRACTOR

Removal

CAUTION:

FRONT SEAT BELT

< REMOVAL AND INSTALLATION >

Before servicing the SRS, turn the ignition switch off, disconnect both battery terminals and wait at least three minutes.

1. Disconnect both the negative and positive battery terminals, then wait at least three minutes. Refer to [PG-50. "Removal and Installation \(Battery\)"](#).
2. Slide the front seat to the full forward position.
3. Remove the center pillar lower finisher. Refer to [INT-27. "CENTER PILLAR LOWER FINISHER : Removal and Installation"](#).
4. Release the floor trim hold downs (1) and pull floor trim back. (B): Lap belt pre-tensioner anchor bolt
5. Disconnect the harness connector (A) from the lap belt pre-tensioner.

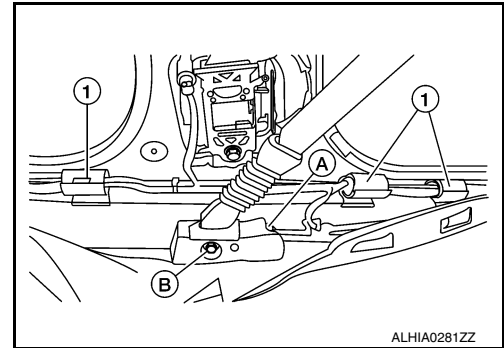

CAUTION:

- For removing/installing the lap belt pre-tensioner harness connector, insert a thin screwdriver wrapped in tape into the notch, then lift the lock and remove the harness connector as shown.
- Install the harness connector with the lock raised, and push the lock into the harness connector as shown.
- After installing the harness connector, check that the lock is pushed in securely.

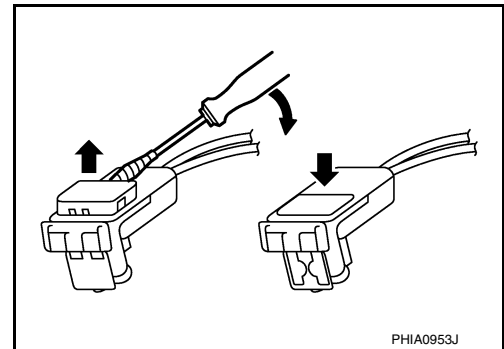

6. Remove the lap belt pre-tensioner anchor bolt.
7. Remove the seat belt height adjuster cover, then remove D-ring anchor bolt.
8. Disconnect the harness connector from the shoulder belt pre-tensioner.

CAUTION:

- For removing/installing the shoulder belt pre-tensioner harness connector, insert a thin screwdriver wrapped in tape into the notch, then lift the lock and remove the harness connector as shown.
- Install the harness connector with the lock raised, and push the lock into the harness connector as shown.
- After installing the harness connector, check that the lock is pushed in securely.

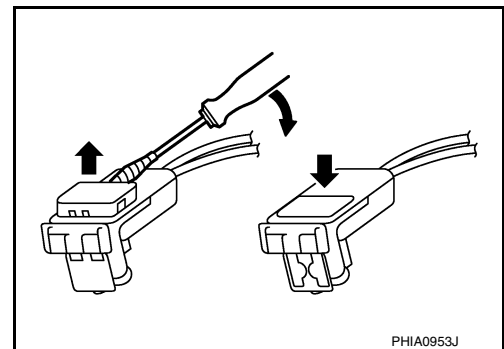

9. Remove the seat belt retractor anchor bolt and upper bolt, then remove the seat belt retractor.

Installation

Installation is in the reverse order of removal.

- Install the seat belt retractor upper bolt first.
- Make sure the seat belt height adjuster is locked in the lowest position during installation.
- Tighten the seat belt retractor bolts to specification. Refer to [SB-8. "Exploded View"](#).
- Make sure both the D-ring anchor and seat belt height adjuster operate freely.
- Always perform an inspection after repair to be sure the system is functioning within specifications. Refer to [SB-5. "Inspection"](#).

FRONT SEAT BELT

< REMOVAL AND INSTALLATION >

SEAT BELT HEIGHT ADJUSTER

Removal

1. Remove the center pillar upper finisher. Refer to [INT-28, "CENTER PILLAR UPPER FINISHER : Removal and Installation"](#).
2. Remove the D-ring anchor bolt.
3. Remove the seat belt height adjuster bolts and the seat belt height adjuster.

Installation

Installation is in the reverse order of removal.

- Make sure that the seat belt height adjuster is locked in the lowest position during installation.
- Make sure both the D-ring anchor and seat belt height adjuster operate freely.
- Tighten the D-ring anchor bolt and seat belt height adjuster bolts to specification. Refer to [SB-8, "Exploded View"](#).

SEAT BELT BUCKLE

Removal

1. Remove the front seat assembly. Refer to [SE-18, "DRIVER SIDE : Removal and Installation - Seat Assembly"](#) (front seat driver side) or [SE-20, "PASSENGER SIDE : Removal and Installation - Seat Assembly"](#) (front seat passenger side).
2. Disconnect the harness connector from the seat belt buckle.
3. Remove the seat belt buckle anchor bolt and the seat belt buckle.

Installation

Installation is in the reverse order of removal.

- During installation, make sure the seat belt buckle anchor bolt (A) is inserted through the components in the following order:

1.	Wave washer
2.	Seat belt buckle
3.	Spacer
4.	Star washer

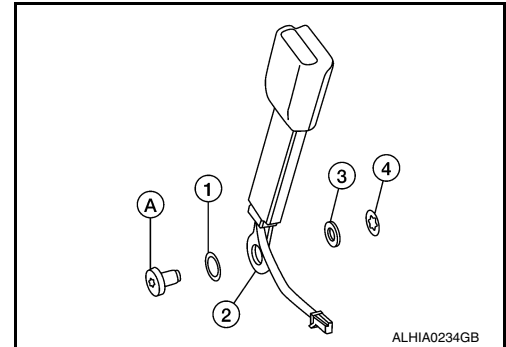

- Tighten the seat belt buckle anchor bolt to specification. Refer to [SB-8, "Exploded View"](#).

REAR SEAT BELT

< REMOVAL AND INSTALLATION >

REAR SEAT BELT

Exploded View - Seat Belt Retractor

INFOID:000000009756330

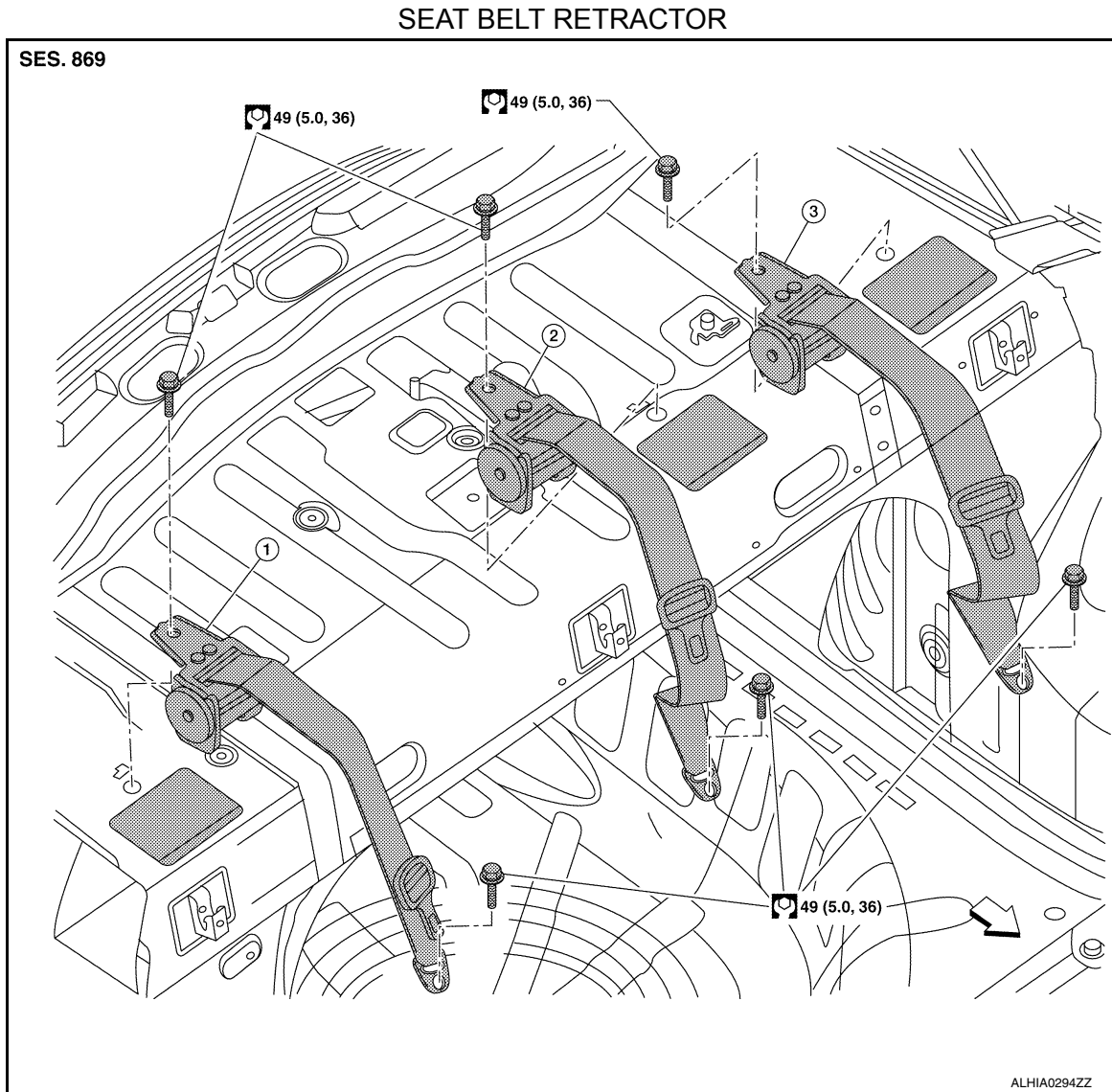

1. Seat belt retractor (RH)

2. Seat belt retractor (center)

3. Seat belt retractor (LH)

⇐ Front

Removal and Installation - Seat Belt Retractor

INFOID:000000009756331

REMOVAL

1. Remove the rear parcel shelf finisher. Refer to [INT-33, "Removal and Installation"](#).
2. Remove the seat belt retractor anchor bolt and the seat belt retractor.

INSTALLATION

Installation is in the reverse order of removal.

- Always perform an inspection after repair to be sure the system is functioning within specifications. Refer to [SB-5, "Inspection"](#).
- Tighten the seat belt retractor bolts to specification. Refer to [SB-11, "Exploded View - Seat Belt Retractor"](#).

REAR SEAT BELT

< REMOVAL AND INSTALLATION >

Exploded View - Seat Belt Buckle

INFOID:000000009756332

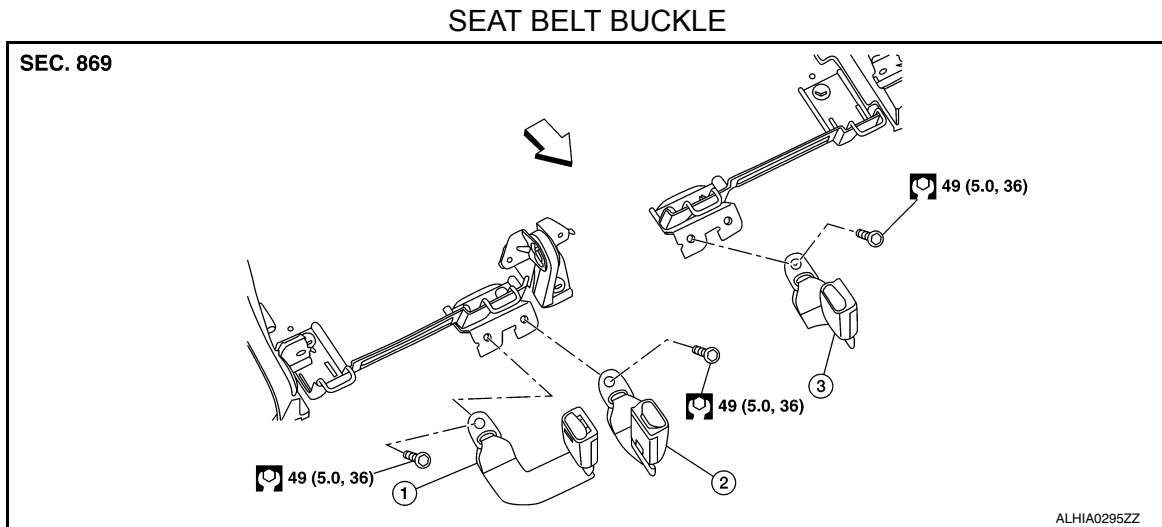

1. Seat belt buckle (RH)

2. Seat belt buckle (center)

3. Seat belt buckle (LH)

⇐ Front

Removal and Installation - Seat Belt Buckle

INFOID:000000009756333

REMOVAL

1. Remove rear seat cushion assembly. Refer to [SE-23, "Removal and Installation - Seat Cushion Assembly"](#).
2. Remove seat belt buckle anchor bolt and the seat belt buckle.

INSTALLATION

Installation is in the reverse order of removal.

- Always perform an inspection after repair to be sure the system is functioning within specifications. Refer to [SB-5, "Inspection"](#).
- Tighten the seat belt buckle anchor bolt to specification. Refer to [SB-11, "Exploded View - Seat Belt Retractor"](#).

LATCH SYSTEM FOR CHILDREN

< REMOVAL AND INSTALLATION >

LATCH SYSTEM FOR CHILDREN

Exploded View

INFOID:000000009756334

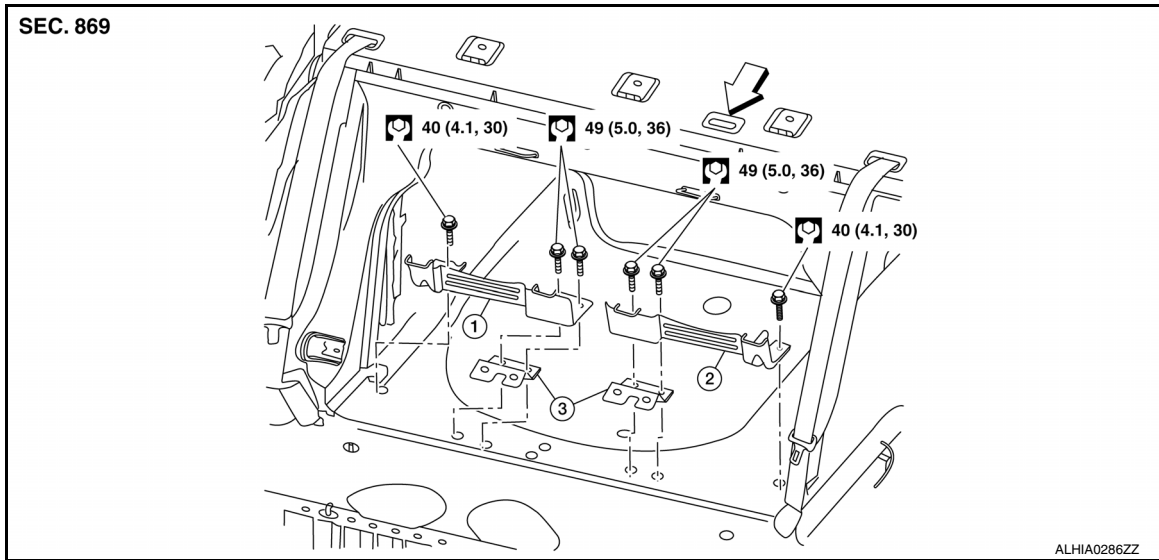

1. LATCH bracket (RH)

2. LATCH bracket (LH)

3. Seat belt buckle anchor bracket

← Front

Removal and Installation

INFOID:000000009756335

REMOVAL

1. Remove the rear seat cushion assembly. Refer to [SE-23, "Removal and Installation - Seat Cushion Assembly"](#)
2. Remove the rear seatback assembly. Refer to [SE-23, "Removal and Installation - 60:40 Split Seatback"](#).
3. Remove the LATCH bracket bolts and the LATCH bracket.

INSTALLATION

Installation is in the reverse order of removal.

- Always perform an inspection after repair to be sure the system is functioning within specifications. Refer to [SB-5, "Inspection"](#).
- Tighten the LATCH bracket bolts to specification. Refer to [SB-13, "Exploded View"](#).

TOP TETHER STRAP CHILD RESTRAINT

< REMOVAL AND INSTALLATION >

TOP TETHER STRAP CHILD RESTRAINT

Removal and Installation

INFOID:000000009756336

The top tether strap child restraint system components (1) are part of the vehicle structure and are not serviceable.

