

SECTION **FAX**
FRONT AXLE

A
B
C

FAX

CONTENTS

E

PRECAUTION	2	TRANSAXLE SIDE	17	F
PRECAUTIONS	2	TRANSAXLE SIDE : Removal and Installation	17	
Precaution for Supplemental Restraint System (SRS) "AIR BAG" and "SEAT BELT PRE-TENSIONER"	2	Inspection	17	
Precautions for Drive Shaft	2	FRONT DRIVE SHAFT	18	G
PREPARATION	3	6M/T	18	
PREPARATION	3	6M/T : Exploded View (LH)	18	H
Special Service Tool	3	6M/T : Removal and Installation (LH)	18	
Commercial Service Tools	3	6M/T : Exploded View (RH)	21	
SYMPTOM DIAGNOSIS	5	6M/T : Removal and Installation (RH)	21	I
NOISE, VIBRATION AND HARSHNESS (NVH) TROUBLESHOOTING	5	6M/T : Inspection	24	
NVH Troubleshooting Chart	5	EXCEPT 6M/T	25	J
PERIODIC MAINTENANCE	6	EXCEPT 6M/T : Exploded View	25	
FRONT WHEEL HUB AND KNUCKLE	6	EXCEPT 6M/T : Removal and Installation	26	
Inspection	6	EXCEPT 6M/T : Inspection	28	K
FRONT DRIVE SHAFT	7	UNIT DISASSEMBLY AND ASSEMBLY ...	30	
Inspection	7	FRONT DRIVE SHAFT	30	L
REMOVAL AND INSTALLATION	8	6M/T	30	
FRONT WHEEL HUB	8	6M/T : Exploded View (LH)	30	
Exploded View	8	6M/T : Disassembly and Assembly (LH)	30	M
Removal and Installation	8	6M/T : Exploded View (RH)	35	
Inspection	10	6M/T : Disassembly and Assembly (RH)	36	
FRONT DRIVE SHAFT BOOT	12	EXCEPT 6M/T	42	N
Exploded View	12	EXCEPT 6M/T : Exploded View	42	
WHEEL SIDE	13	EXCEPT 6M/T : Disassembly and Assembly	43	
WHEEL SIDE : Removal and Installation	13	SERVICE DATA AND SPECIFICATIONS (SDS)	49	O
		SERVICE DATA AND SPECIFICATIONS (SDS)	49	P
		Wheel Bearing	49	
		Drive Shaft	49	

PRECAUTIONS

< PRECAUTION >

PRECAUTION

PRECAUTIONS

Precaution for Supplemental Restraint System (SRS) "AIR BAG" and "SEAT BELT PRE-TENSIONER"

INFOID:000000011538175

The Supplemental Restraint System such as "AIR BAG" and "SEAT BELT PRE-TENSIONER", used along with a front seat belt, helps to reduce the risk or severity of injury to the driver and front passenger for certain types of collision. Information necessary to service the system safely is included in the SR and SB section of this Service Manual.

WARNING:

- To avoid rendering the SRS inoperative, which could increase the risk of personal injury or death in the event of a collision which would result in air bag inflation, all maintenance must be performed by an authorized NISSAN/INFINITI dealer.
- Improper maintenance, including incorrect removal and installation of the SRS, can lead to personal injury caused by unintentional activation of the system. For removal of Spiral Cable and Air Bag Module, see the SR section.
- Do not use electrical test equipment on any circuit related to the SRS unless instructed to in this Service Manual. SRS wiring harnesses can be identified by yellow and/or orange harnesses or harness connectors.

PRECAUTIONS WHEN USING POWER TOOLS (AIR OR ELECTRIC) AND HAMMERS

WARNING:

- When working near the Airbag Diagnosis Sensor Unit or other Airbag System sensors with the Ignition ON or engine running, DO NOT use air or electric power tools or strike near the sensor(s) with a hammer. Heavy vibration could activate the sensor(s) and deploy the air bag(s), possibly causing serious injury.
- When using air or electric power tools or hammers, always switch the Ignition OFF, disconnect the battery and wait at least three minutes before performing any service.

Precautions for Drive Shaft

INFOID:000000011538176

Observe the following precautions when disassembling and assembling drive shaft.

- Do not disassemble joint sub-assembly because it is non-overhaul parts.
- Perform work in a location which is as dust-free as possible.
- Clean the parts before disassembling and assembling.
- Prevent the entry of foreign objects during disassembly of the service location.
- Reassemble disassembled parts carefully in the correct order. If work is interrupted, a clean cover must be placed over parts.
- Use paper shop cloths. Fabric shop cloths must not be used because of the danger of lint adhering to parts.
- Clean disassembled parts (except for rubber parts) with kerosene which shall be removed by blowing with air or wiping with paper shop cloths.

PREPARATION

< PREPARATION >

PREPARATION

PREPARATION

Special Service Tool

INFOID:000000011538177

The actual shape of the tools may differ from those illustrated here.

Tool number (TechMate No.) Tool name	Description
KV40107300 (—) Boot band crimping tool	Installing boot band
KV40107500 (—) Drive shaft attachment	Removing drive shaft
KV38107900 (—) Protector	Installing drive shaft a: 32 mm (1.26 in) dia.
KV40104000 (—) Hub lock nut wrench	Removing and Installing wheel hub lock nut. a: 85 mm (3.35 in) b: 65 mm (2.56 in)



Commercial Service Tools

INFOID:000000011538178

A
B
C
FAX
E
F
G
H
I
J
K
L
M
N
O
P

PREPARATION

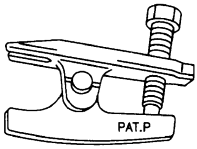
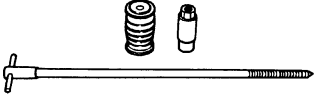
< PREPARATION >

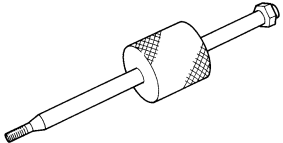
Tool name	Description
<p data-bbox="131 184 324 220">Ball joint remover</p>  <p data-bbox="863 415 909 430">NT146</p>	<p data-bbox="1036 184 1266 220">Removing wheel stud</p>
<p data-bbox="131 443 324 478">Drive shaft puller</p>  <p data-bbox="863 667 954 682">JPDIG0152ZZ</p>	<p data-bbox="1036 443 1453 478">Removing drive shaft joint sub assembly</p>
<p data-bbox="131 695 259 730">Power tool</p>  <p data-bbox="863 919 941 934">PIIB1407E</p>	<p data-bbox="1036 695 1380 730">Loosening nuts, screws and bolts</p>
<p data-bbox="131 947 308 982">Sliding hammer</p>  <p data-bbox="863 1171 933 1186">ZZA0023D</p>	<p data-bbox="1036 947 1266 982">Removing drive shaft</p>

NOISE, VIBRATION AND HARSHNESS (NVH) TROUBLESHOOTING

< SYMPTOM DIAGNOSIS >

SYMPTOM DIAGNOSIS

NOISE, VIBRATION AND HARSHNESS (NVH) TROUBLESHOOTING

NVH Troubleshooting Chart

INFOID:0000000011538179

Use chart below to find the cause of the symptom. If necessary, repair or replace these parts.

Reference			—	FAX-24, "6M/T : Inspection"	—	FAX-8, "Exploded View"	—	FAX-10, "Inspection"	FSU-4, "NVH Troubleshooting Chart"	Refer to FRONT AXLE in this chart	WT-45, "NVH Troubleshooting Chart"	WT-45, "NVH Troubleshooting Chart"	Refer to DRIVE SHAFT in this chart	BR-7, "NVH Troubleshooting Chart"	ST-9, "NVH Troubleshooting Chart"	
Possible cause and SUSPECTED PARTS			Excessive joint angle	Joint sliding resistance	Imbalance	Improper installation, looseness	Parts interference	Wheel bearing damage	FRONT SUSPENSION	FRONT AXLE	TIRE	ROAD WHEEL	DRIVE SHAFT	BRAKE	STEERING	
Symptom	DRIVE SHAFT	Noise	x	x				x	x	x	x	x		x	x	
		Shake	x		x			x	x	x	x	x		x	x	
	FRONT AXLE	Noise				x	x	x	x		x	x	x	x	x	x
		Shake				x	x	x	x		x	x	x	x	x	x
		Vibration				x	x	x	x		x		x			x
		Shimmy				x	x		x		x	x		x	x	x
		Shudder				x			x		x	x		x		x
		Poor quality ride or handling				x	x		x		x	x				

x: Applicable

A
B
C
D
E
F
G
H
I
J
K
L
M
N
O
P

FAX

FRONT WHEEL HUB AND KNUCKLE

< PERIODIC MAINTENANCE >

PERIODIC MAINTENANCE

FRONT WHEEL HUB AND KNUCKLE

Inspection

INFOID:000000011538180

COMPONENT PART

Check that the mounting conditions (looseness, backlash) of each component and component conditions (wear, damage) are normal.

WHEEL HUB ASSEMBLY (BEARING-INTEGRATED TYPE)

Check the following items, and replace the part if necessary.

- Move the wheel hub and bearing in the axial direction by hand. Make sure there is no looseness in the wheel hub and bearing.

Axial end play : Refer to [FAX-49, "Wheel Bearing"](#).

- Rotate the wheel hub and bearing and make sure there is no unusual noise or other irregular conditions. If there are any irregular conditions, replace wheel hub and bearing.

FRONT DRIVE SHAFT

< PERIODIC MAINTENANCE >

FRONT DRIVE SHAFT

Inspection

INFOID:0000000011538181

Check the following items, and replace the part if necessary.

- Check drive shaft mounting point and joint for looseness and other damage.

CAUTION:

Replace entire drive shaft assembly when noise or vibration occurs from drive shaft.

- Check boot for cracks and other damage.

A

B

C

FAX

E

F

G

H

I

J

K

L

M

N

O

P

FRONT WHEEL HUB

< REMOVAL AND INSTALLATION >

REMOVAL AND INSTALLATION

FRONT WHEEL HUB

Exploded View

INFOID:000000011538182

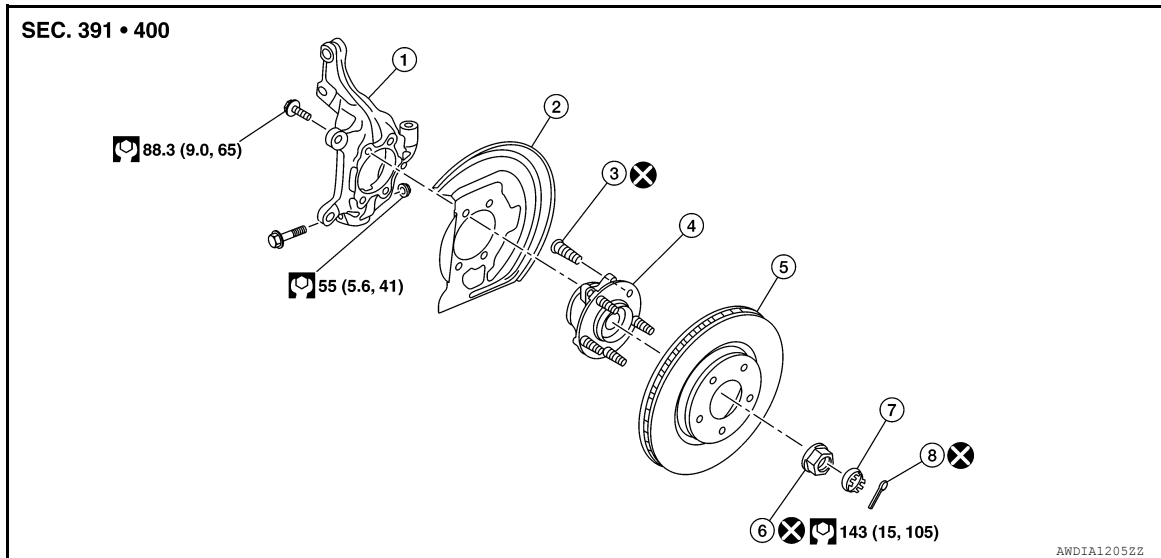

- | | | |
|--------------------------|---------------------|-----------------------|
| 1. Steering knuckle | 2. Splash guard | 3. Wheel stud |
| 4. Wheel hub and bearing | 5. Disc brake rotor | 6. Wheel hub lock nut |
| 7. Nut retainer | 8. Cotter pin | |

Removal and Installation

INFOID:000000011538183

REMOVAL

1. Remove the wheel and tire using power tool. Refer to [WT-47, "Exploded View"](#).
2. Remove the brake caliper torque member bolts, leaving the brake hose attached. Position the brake caliper aside with wire. Refer to [BR-39, "BRAKE CALIPER ASSEMBLY : Removal and Installation"](#).

CAUTION:

Do not depress the brake pedal while the brake caliper is removed.

3. Put alignment marks (A) on the disc brake rotor and on the wheel hub and bearing. Remove the disc brake rotor.

CAUTION:

Do not drop the disc brake rotor.

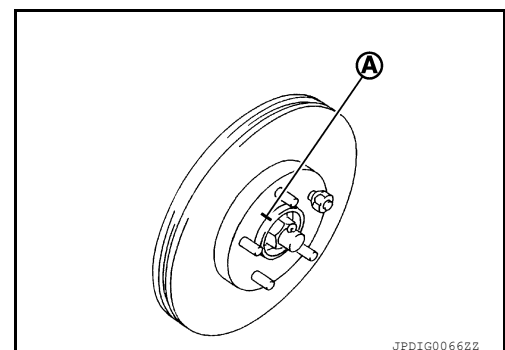

4. Remove the wheel sensor bolt. Position the wheel sensor and the wheel sensor harness aside. Refer to [BRC-113, "FRONT WHEEL SENSOR : Removal and Installation"](#).
5. Remove the cotter pin from the drive shaft.
6. Remove the nut retainer from the wheel hub lock nut.

FRONT WHEEL HUB

< REMOVAL AND INSTALLATION >

7. Hold the wheel hub and bearing using Tool (A). Loosen the wheel hub lock nut.

Tool number

(A): KV40104000 (—)

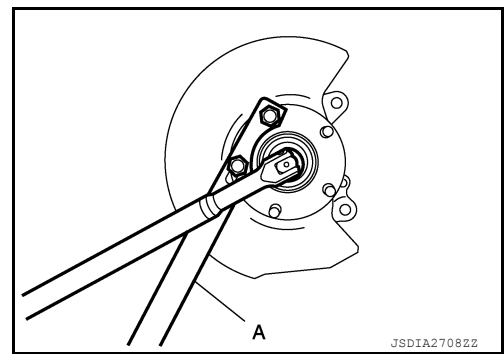

8. Using a piece of wood and a suitable tool, tap on the wheel hub lock nut to disengage the drive shaft from the wheel hub and bearing.

CAUTION:

- Do not place the drive shaft joint at an extreme angle. Also be careful not to overextend slide joint.
- Do not allow the drive shaft to hang down without support.

NOTE:

Use a suitable puller if the drive shaft cannot be separated from the wheel hub and bearing even after performing the above procedure.

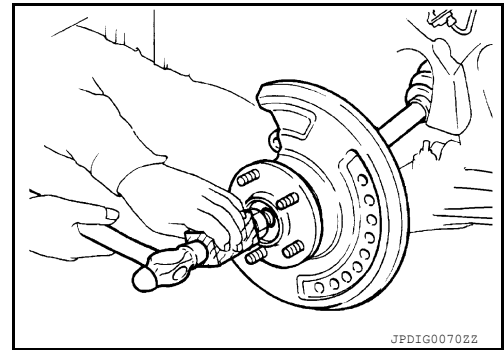

9. Remove the wheel hub lock nut.
10. Remove the bolts and the wheel hub and bearing from the steering knuckle.
11. Remove the splash guard from the steering knuckle.
12. Suspend the drive shaft with suitable wire.
13. If necessary, remove the wheel studs (1) from the wheel hub and bearing using a suitable tool (A).

CAUTION:

- Remove the wheel studs only when necessary.
- Do not hammer the wheel studs or damage to the wheel hub and bearing may occur.
- Pull out the wheel studs in a direction perpendicular to the wheel hub and bearing.

14. Inspect the components. Refer to [FAX-10, "Inspection"](#).

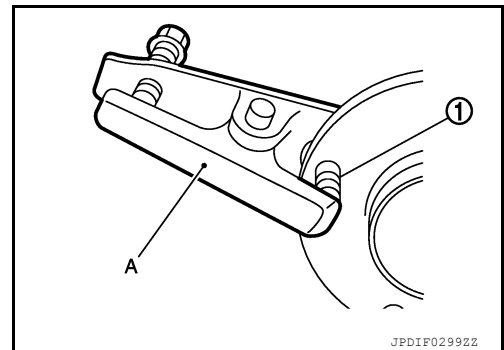

INSTALLATION

Installation is in the reverse order of removal.

- Place a washer (A) as shown to install the wheel studs (1) by using the tightening force of the nut (B).

CAUTION:

- Do not reuse the wheel stud.
- Check that there is no clearance between the wheel stud and the wheel hub and bearing.

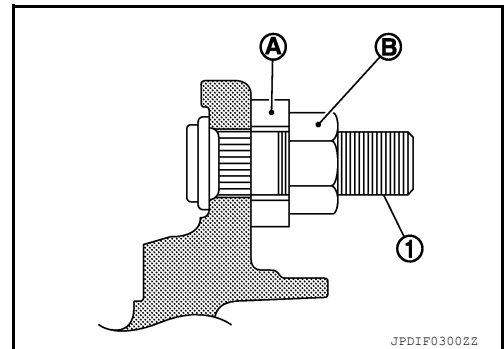

- Clean the mating surfaces of the wheel hub lock nut and the wheel hub and bearing.

CAUTION:

Do not apply lubricating oil to these mating surfaces.

A
B
C
FAX
E
F
G
H
I
J
K
L
M
N
O
P

FRONT WHEEL HUB

< REMOVAL AND INSTALLATION >

- Clean the mating surfaces of the joint sub-assembly and the wheel hub and bearing. Apply Molykote M77 lubricant to the surface (A) of the joint sub-assembly.

CAUTION:

Apply lubricant to cover the entire flat mating surface of the joint sub-assembly.

NOTE:

Always check with the Parts Department for the latest parts information.

Amount of lubricant : Refer to [FAX-49, "Drive Shaft"](#).

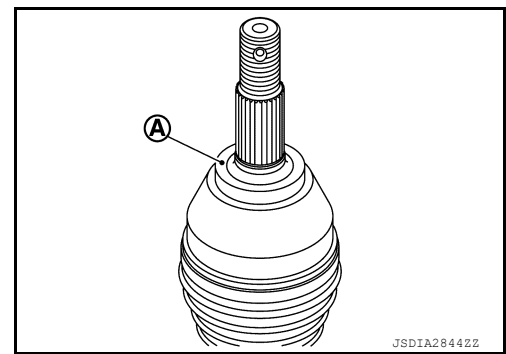

- Hold the wheel hub and bearing using Tool. Tighten the wheel hub lock nut.

CAUTION:

- Since the drive shaft is assembled by press-fitting, use a torque wrench to tighten the wheel hub lock nut. Do not use a power tool.
- Too much torque causes axle noise. Too little torque causes wheel bearing looseness. Tighten the wheel hub lock nut to the specification.

Tool number : KV40104000 (—)

- When installing the cotter pin (1) and the nut retainer (2), securely bend the cotter pin to prevent rattles.

CAUTION:

Do not reuse the cotter pin.

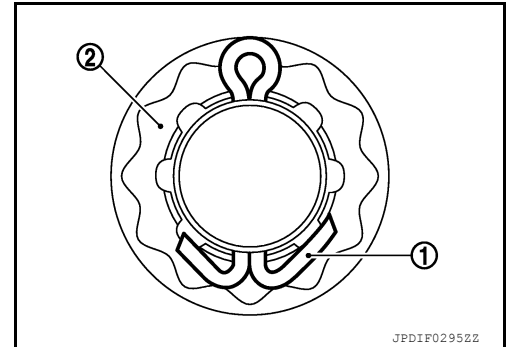

- Align the matching marks (A) on the disc brake rotor and on the wheel hub and bearing.

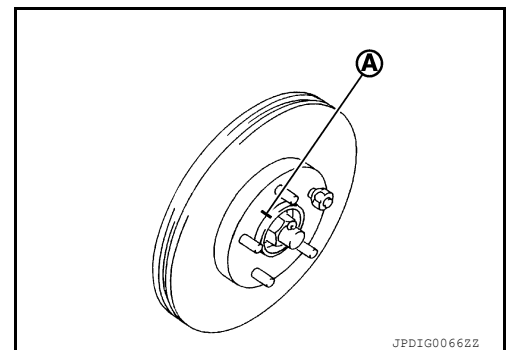

- Complete the inspection. Refer to [FAX-17, "Inspection"](#).

Inspection

INFOID:000000011538184

INSPECTION AFTER REMOVAL

Check the following items, and replace the part if necessary.

- Check components for deformation, cracks, and other damage.
- Check boots of transverse link and steering outer socket ball joint for breakage, axial end play, and swing torque.
- Transverse link: Refer to [FSU-10, "Inspection"](#).
- Steering outer socket: Refer to [ST-8, "Inspection"](#).

INSPECTION AFTER INSTALLATION

FRONT WHEEL HUB

< REMOVAL AND INSTALLATION >

1. Check the wheel sensor harness to be sure the connectors are fully seated.
2. Check the wheel alignment. Refer to [FSU-6, "Inspection"](#).

A

B

C

FAX

E

F

G

H

I

J

K

L

M

N

O

P

FRONT DRIVE SHAFT BOOT

< REMOVAL AND INSTALLATION >

FRONT DRIVE SHAFT BOOT

Exploded View

INFOID:000000011538185

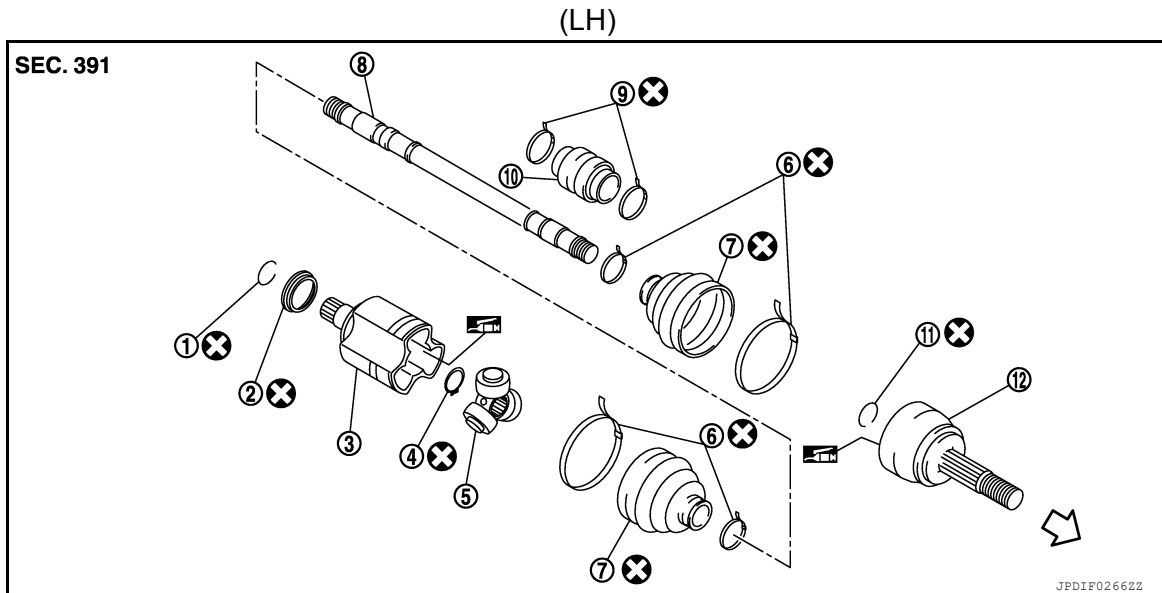

- | | | |
|--------------------|--------------------|------------------------|
| 1. Circular clip | 2. Dust shield | 3. Slide joint housing |
| 4. Snap ring | 5. Spider assembly | 6. Boot band |
| 7. Boot | 8. Shaft | 9. Damper band |
| 10. Dynamic damper | 11. Circular clip | 12. Joint sub-assembly |
- ← Wheel side

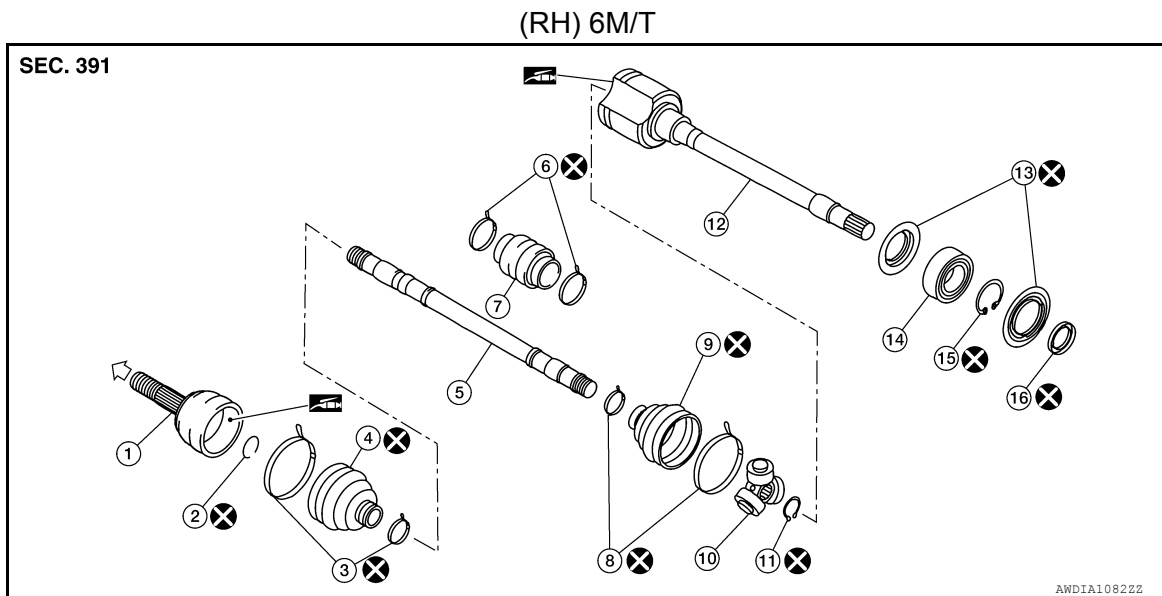

- | | | |
|-----------------------|------------------|-------------------------|
| 1. Joint sub-assembly | 2. Circular clip | 3. Boot band |
| 4. Boot | 5. Shaft | 6. Damper band |
| 7. Dynamic damper | 8. Boot band | 9. Boot |
| 10. Spider assembly | 11. Snap ring | 12. Slide joint housing |

FRONT DRIVE SHAFT BOOT

< REMOVAL AND INSTALLATION >

- | | | |
|-----------------|---------------------|---------------|
| 13. Dust shield | 14. Support bearing | 15. Snap ring |
| 16. Dust shield | ⇐ Wheel side | |

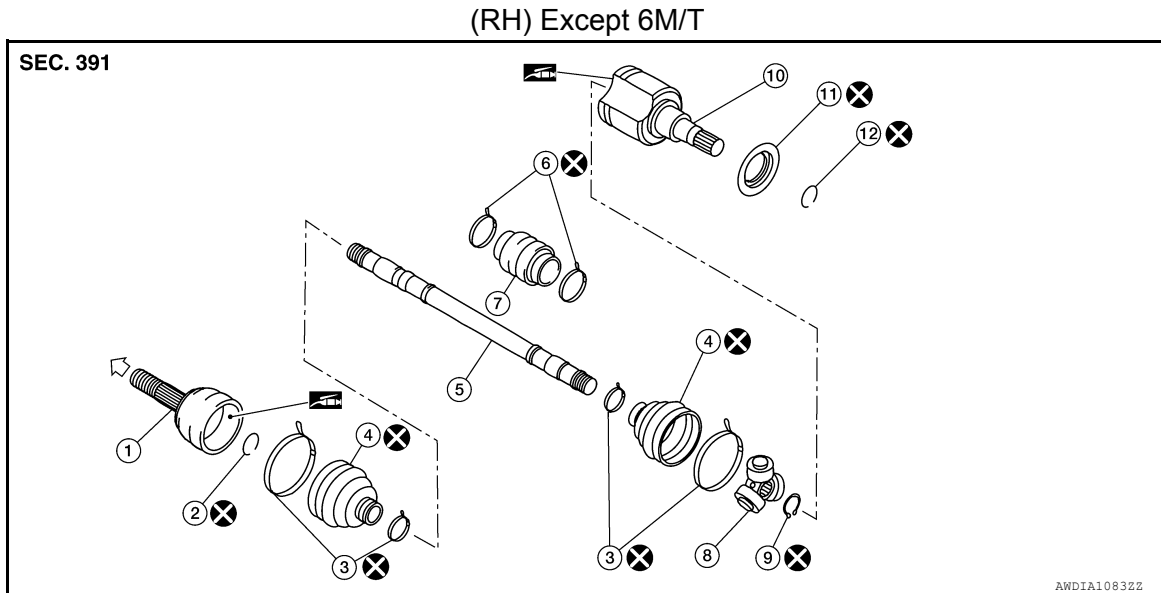

- | | | |
|-------------------------|--------------------|-------------------|
| 1. Joint sub-assembly | 2. Circular clip | 3. Boot band |
| 4. Boot | 5. Shaft | 6. Damper band |
| 7. Dynamic damper | 8. Spider assembly | 9. Snap ring |
| 10. Slide joint housing | 11. Dust shield | 12. Circular clip |
- ⇐ Wheel side

WHEEL SIDE

WHEEL SIDE : Removal and Installation

INFOID:000000011538186

REMOVAL

1. Remove the wheel and tire using power tool. Refer to [WT-47, "Exploded View"](#).
2. Remove the brake caliper torque member bolts, leaving the brake hose attached. Position the brake caliper aside with wire. Refer to [BR-39, "BRAKE CALIPER ASSEMBLY : Removal and Installation"](#).

CAUTION:

Do not depress the brake pedal while the brake caliper is removed.

3. Put alignment marks (A) on the disc brake rotor and on the wheel hub and bearing. Remove the disc brake rotor.

CAUTION:

Do not drop the disc brake rotor.

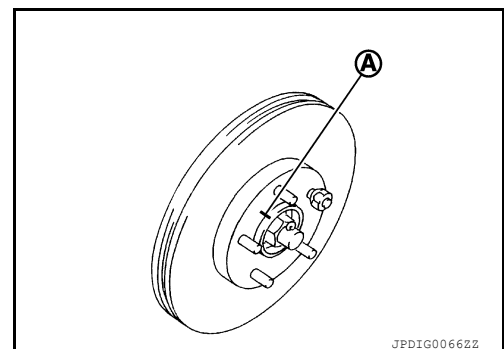

4. Remove the wheel sensor bolt. Position the wheel sensor and the wheel sensor harness aside. Refer to [BRC-113, "FRONT WHEEL SENSOR : Removal and Installation"](#).
5. Remove the cotter pin from the drive shaft.
6. Remove the nut retainer from the wheel hub lock nut.

FRONT DRIVE SHAFT BOOT

< REMOVAL AND INSTALLATION >

7. Hold the wheel hub and bearing using Tool (A). Loosen the wheel hub lock nut.

Tool number

(A): KV40104000 (—)

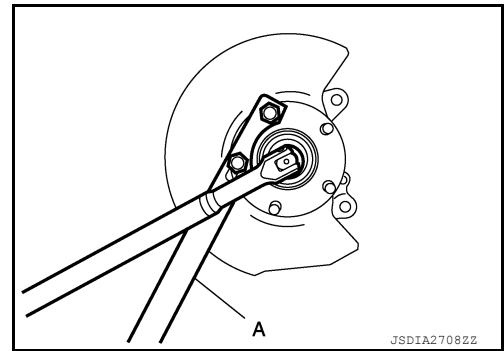

8. Using a piece of wood and a suitable tool, tap on the wheel hub lock nut to disengage the drive shaft from the wheel hub and bearing.

CAUTION:

- Do not place the drive shaft joint at an extreme angle. Also be careful not to overextend slide joint.
- Do not allow the drive shaft to hang down without support.

NOTE:

Use a suitable puller if the drive shaft cannot be separated from the wheel hub and bearing even after performing the above procedure.

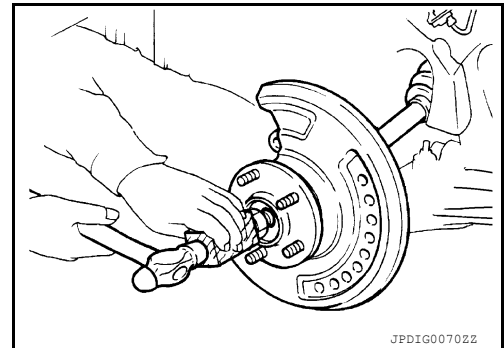

9. Remove the wheel hub lock nut.
10. Remove the nut and bolt from the lower ball joint. Disconnect the steering knuckle from the transverse link.
11. Remove the drive shaft from the wheel hub and bearing.
12. Remove the boot bands.
13. Separate the boot from the joint sub-assembly.

14. Screw a suitable tool (A) into the joint sub-assembly screw part to a length of 30 mm (1.18 in) or more. Support the drive shaft with one hand and pull out the joint sub-assembly from the shaft.

CAUTION:

- Align the suitable tool and the drive shaft. Remove the joint sub-assembly by pulling firmly and uniformly.
- If the joint sub-assembly cannot be pulled out, try after removing the drive shaft from the vehicle. Refer to [FAX-30, "6M/T : Disassembly and Assembly \(LH\)"](#).

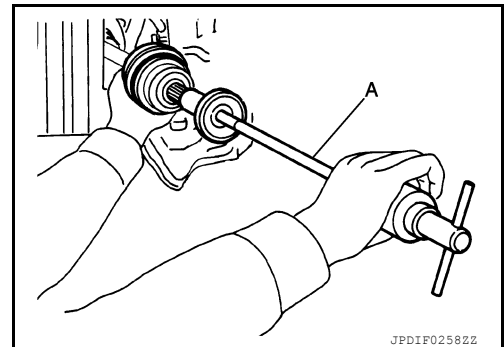

15. Remove the circular clip (1) from the shaft.
16. Remove the outer boot from the shaft.

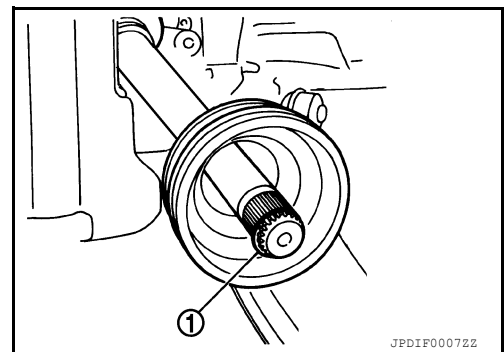

INSTALLATION

1. Clean the old grease from the joint sub-assembly using paper shop cloths.

FRONT DRIVE SHAFT BOOT

< REMOVAL AND INSTALLATION >

2. Fill the serration slot on the joint sub-assembly (1) with NISSAN Genuine grease or equivalent until the serration slot and ball groove become full to the brim.

CAUTION:

After applying the grease, use paper shop cloths to wipe off the grease that has oozed out.

NOTE:

Always check with the Parts Department for the latest parts information.

3. Install the outer boot and the boot bands to the shaft.

CAUTION:

• **Wrap the serration on the shaft with tape to protect the boot from damage.**

• **Do not reuse the boot.**

• **Do not reuse the boot bands.**

4. Remove the tape wrapped around the serration on the shaft.

5. Position the circular clip (1) on the groove at the shaft edge.

CAUTION:

Do not reuse the circular clip.

NOTE:

A drive joint inserter is recommended when installing the circular clip.

6. Align with the shaft and the joint sub-assembly. Assemble the shaft with the joint sub-assembly while holding the circular clip.

7. Install the joint sub-assembly (1) to the shaft using a suitable tool.

CAUTION:

• **Make sure the circular clip is properly positioned on the groove of the joint sub-assembly.**

• **Confirm that the joint sub-assembly is correctly engaged while rotating the drive shaft.**

8. Apply the specified amount of grease to the inside of the large diameter side of the boot.

NOTE:

Always check with the Parts Department for the latest parts information.

Grease amount : Refer to [FAX-49, "Drive Shaft"](#).

9. Install the boot securely into the grooves (indicated by "*" marks) as shown.

CAUTION:

If there is grease on the boot mounting surfaces (indicated by "*" marks) on the shaft or the joint sub-assembly, the boot may come off. Remove all grease from the boot mounting surfaces.

10. To prevent the deformation of the boot, adjust the boot installation length to the specified value by inserting a suitable tool into the inside of the boot from the large diameter side of the boot and discharging the inside air.

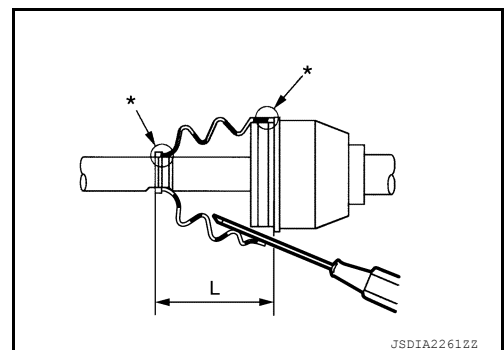
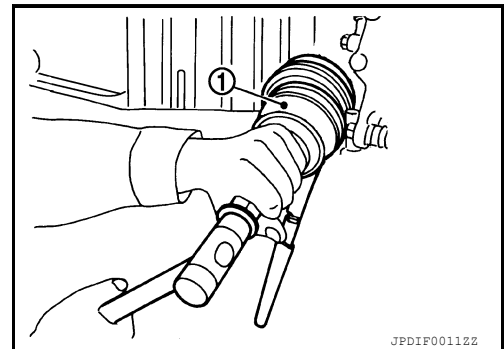
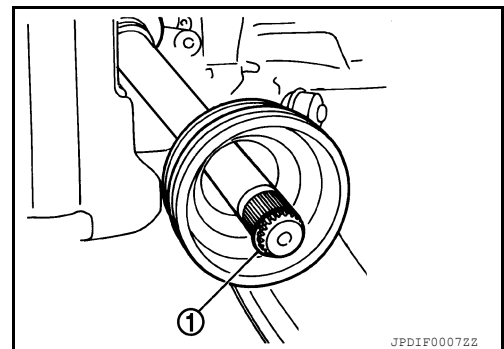
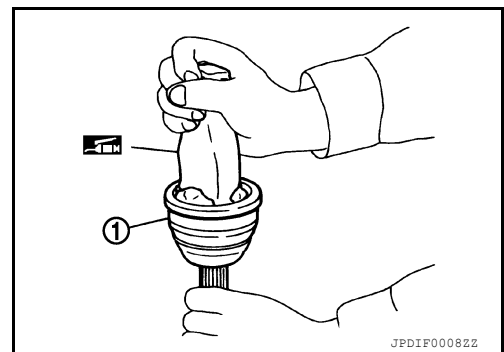

A
B
C
FAX
E
F
G
H
I
J
K
L
M
N
O
P

FRONT DRIVE SHAFT BOOT

< REMOVAL AND INSTALLATION >

Boot installation length (L) : Refer to [FAX-49, "Drive Shaft"](#).

CAUTION:

- The boot may break if the boot installation length is not correct.
- Be careful not to touch the inside of the boot with the tip of the suitable tool.

11. Install new large and small boot bands securely using Tool (A).

CAUTION:

Do not reuse the boot bands.

Tool number (A): KV40107300 (—)

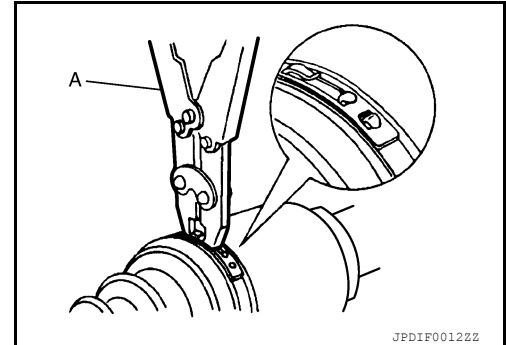

12. Secure the boot band so that dimension (A) meets the specification.

Dimension (A) : Refer to [FAX-49, "Drive Shaft"](#).

13. Attempt to rotate the boot to check whether or not the boot bands are securing the boot. If the boot is not secure, remove the boot bands, reposition the boot, and install new boot bands.

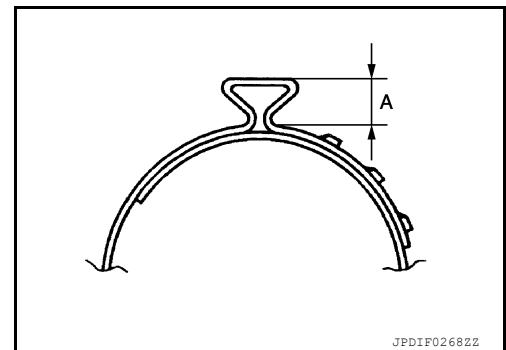

14. Clean the mating surfaces of the wheel hub lock nut and the wheel hub assembly.

CAUTION:

Do not apply lubricating oil to these mating surfaces.

15. Clean the mating surfaces of the joint sub-assembly and the wheel hub and bearing. Apply Molykote M77 lubricant to the surface (A) of the joint sub-assembly.

CAUTION:

Apply lubricant to cover the entire flat mating surface of the joint sub-assembly.

NOTE:

Always check with the Parts Department for the latest parts information.

Amount of lubricant : Refer to [FAX-49, "Drive Shaft"](#).

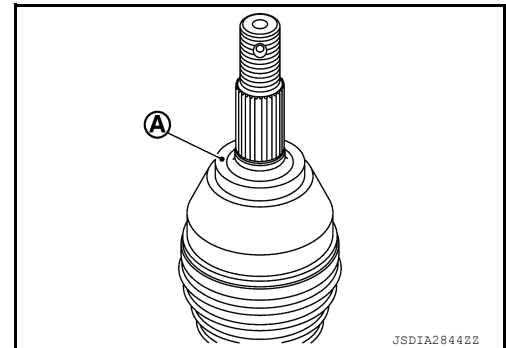

16. Install the drive shaft to the wheel hub and bearing. Temporarily install, but do not tighten, the wheel hub lock nut.

17. Install the transverse link to the steering knuckle with the nut and bolt. Refer to [FAX-8, "Exploded View"](#).

18. Hold the wheel hub and bearing using Tool. Tighten the wheel hub lock nut.

CAUTION:

- Since the drive shaft is assembled by press-fitting, use a torque wrench to tighten the wheel hub lock nut. Do not use a power tool.
- Too much torque causes axle noise. Too little torque causes wheel bearing looseness. Tighten the wheel hub lock nut to the specification.

Tool number (A): KV40104000 (—)

FRONT DRIVE SHAFT BOOT

< REMOVAL AND INSTALLATION >

19. Install the nut retainer (2).
20. Install the cotter pin (1). Securely bend the cotter pin to prevent rattles.
CAUTION:
Do not reuse the cotter pin.

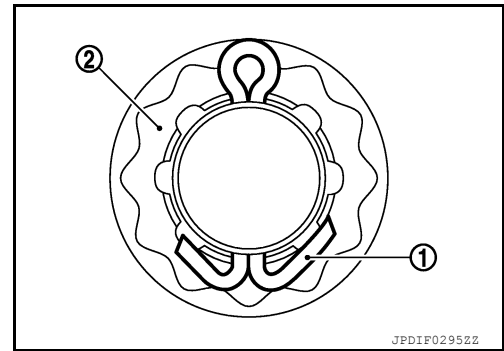

21. Install the wheel sensor, the wheel sensor bolt, and the wheel sensor harness. Refer to [BRC-113, "FRONT WHEEL SENSOR : Removal and Installation"](#).
22. Align the matching marks (A) on the disc brake rotor and on the wheel hub and bearing. Install the disc brake rotor.
CAUTION:
Do not drop the disc brake rotor.

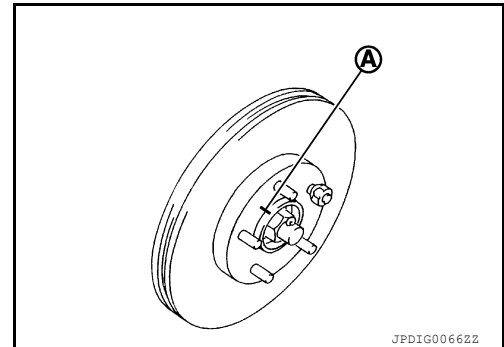

23. Remove the wire from the brake caliper. Install the brake caliper and the brake caliper torque member bolts. Refer to [BR-39, "BRAKE CALIPER ASSEMBLY : Removal and Installation"](#).
CAUTION:
Do not twist the brake hose.
24. Install the wheel and tire. Refer to [WT-47, "Adjustment"](#).
25. Complete the inspection. Refer to [FAX-17, "Inspection"](#).

TRANSAXLE SIDE

TRANSAXLE SIDE : Removal and Installation

INFOID:000000011538187

Remove boot after drive shaft is removed from the vehicle.

- For drive shaft removal and installation, follow the instructions below.
 - 6M/T: Refer to [FAX-18, "6M/T : Removal and Installation \(LH\)"](#).
 - Except 6M/T: Refer to [FAX-26, "EXCEPT 6M/T : Removal and Installation"](#).
- For drive shaft disassembly and assembly.
 - 6M/T: Refer to [FAX-30, "6M/T : Disassembly and Assembly \(LH\)"](#).
 - Except 6M/T: Refer to [FAX-43, "EXCEPT 6M/T : Disassembly and Assembly"](#).

Inspection

INFOID:000000011538188

INSPECTION AFTER INSTALLATION

1. Check the wheel sensor harness to be sure the connectors are fully seated.
2. Check the wheel alignment. Refer to [FSU-6, "Inspection"](#).

FRONT DRIVE SHAFT

< REMOVAL AND INSTALLATION >

FRONT DRIVE SHAFT

6M/T

6M/T : Exploded View (LH)

INFOID:000000011538189

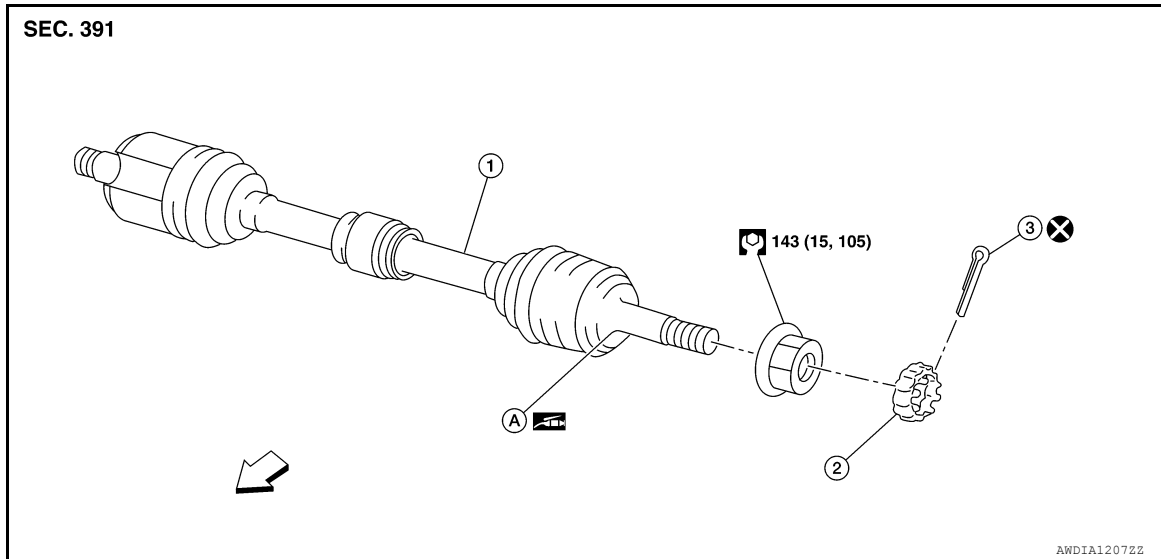

1. Front drive shaft

2. Nut retainer

3. Cotter pin

A. Molykote M77

← Front

6M/T : Removal and Installation (LH)

INFOID:000000011538190

NOTE:

When removing components such as hoses, tubes, lines, etc., cap or plug openings to prevent fluid from spilling.

REMOVAL

1. Remove the wheel and tire using power tool. Refer to [WT-47, "Exploded View"](#).
2. Drain the M/T fluid. Refer to [TM-19, "Draining"](#).
3. Remove the brake caliper torque member bolts, leaving the brake hose attached. Position the brake caliper aside with wire. Refer to [BR-39, "BRAKE CALIPER ASSEMBLY : Removal and Installation"](#).

CAUTION:

Do not depress the brake pedal while the brake caliper is removed.

4. Put alignment marks (A) on the disc brake rotor and on the wheel hub and bearing. Remove the disc brake rotor.

CAUTION:

Do not drop the disc brake rotor.

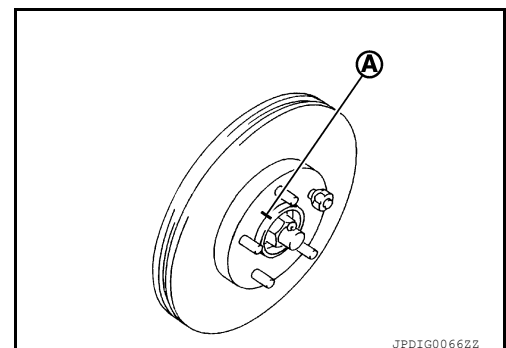

5. Remove the wheel sensor bolt. Position the wheel sensor and the wheel sensor harness aside. Refer to [BRC-113, "FRONT WHEEL SENSOR : Removal and Installation"](#).
6. Remove the cotter pin from the drive shaft.

FRONT DRIVE SHAFT

< REMOVAL AND INSTALLATION >

7. Remove the nut retainer from the wheel hub lock nut.
8. Hold the wheel hub and bearing using Tool (A). Loosen the wheel hub lock nut.

Tool number (A): KV40104000 (—)

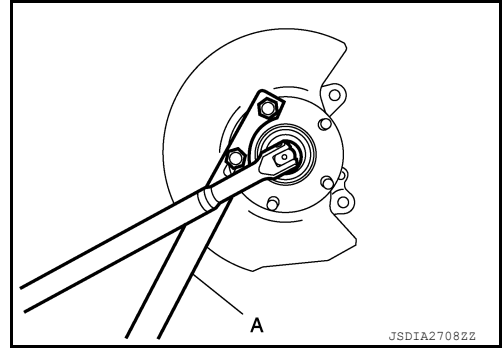

9. Using a piece of wood and a suitable tool, tap on the wheel hub lock nut to disengage the drive shaft from the wheel hub and bearing.

CAUTION:

- Do not place the drive shaft joint at an extreme angle. Also be careful not to overextend slide joint.
- Do not allow the drive shaft to hang down without support.

NOTE:

Use a suitable puller if the drive shaft cannot be separated from the wheel hub and bearing even after performing the above procedure.

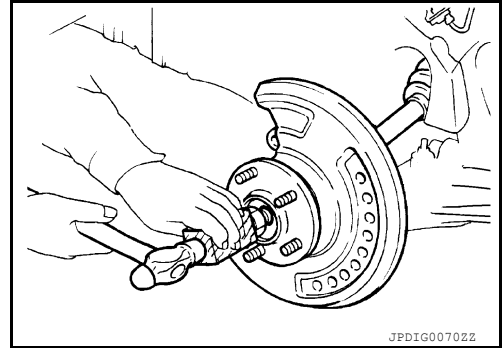

10. Remove the wheel hub lock nut.
11. Remove the nut and bolt from the lower ball joint. Disconnect the steering knuckle from the transverse link.
12. Remove the drive shaft from the wheel hub and bearing.
13. Insert the Tool (A) between the shaft and the transaxle. Install a suitable tool (B) to the Tool (A). Remove the drive shaft from the transaxle.

CAUTION:

Confirm that the circular clip is attached to the drive shaft.

Tool number (A): KV40107500 (—)

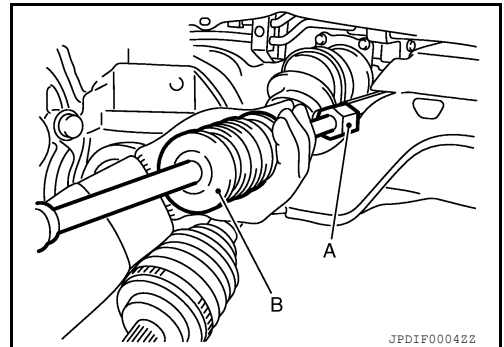

14. Remove the differential side oil seal. Refer to [TM-20, "Removal and Installation"](#).
15. Inspect the components. Refer to [FAX-24, "6M/T : Inspection"](#).

INSTALLATION

Installation is in the reverse order of removal.

TRANSAXLE SIDE

- Install a new differential side oil seal. Refer to [TM-20, "Removal and Installation"](#).

CAUTION:

Do not reuse the differential side oil seal.

FRONT DRIVE SHAFT

< REMOVAL AND INSTALLATION >

- Place Tool (A) onto the differential side oil seal to prevent damage to the oil seal while inserting the drive shaft. Slide drive shaft sliding joint and tap with a hammer to install securely.

CAUTION:

Check that circular clip is completely engaged.

Tool number (A): KV38107900 (—)

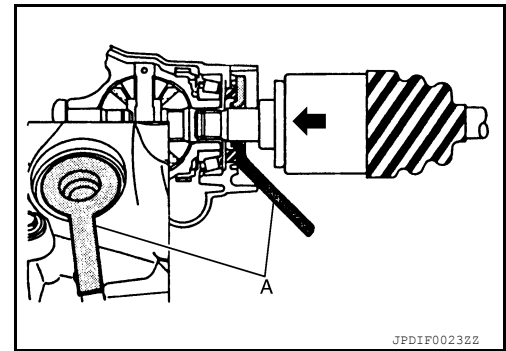

- Refill the M/T oil. Refer to [TM-19, "Refilling"](#).
- Complete the inspection. Refer to [FAX-17, "Inspection"](#).

WHEEL HUB SIDE

- Clean the mating surfaces of the wheel hub lock nut and the wheel hub and bearing.

CAUTION:

Do not apply lubricating oil to these mating surfaces.

- Clean the mating surfaces of the joint sub-assembly and the wheel hub and bearing. Apply Molykote M77 lubricant to the surface (A) of the joint sub-assembly.

CAUTION:

Apply lubricant to cover the entire flat mating surface of the joint sub-assembly.

NOTE:

Always check with the Parts Department for the latest parts information.

Amount of lubricant : Refer to [FAX-49, "Drive Shaft"](#).

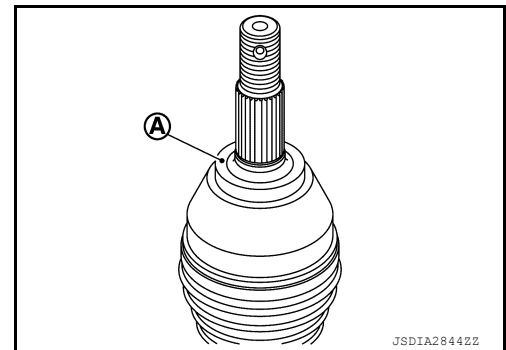

- Hold the wheel hub and bearing using Tool. Tighten the wheel hub lock nut.

CAUTION:

- Since the drive shaft is assembled by press-fitting, use a torque wrench to tighten the wheel hub lock nut. Do not use a power tool.
- Too much torque causes axle noise. Too little torque causes wheel bearing looseness. Tighten the wheel hub lock nut to the specification.

Tool number : KV40104000 (—)

- When installing the cotter pin (1) and the nut retainer (2), securely bend the cotter pin to prevent rattles.

CAUTION:

Do not reuse the cotter pin.

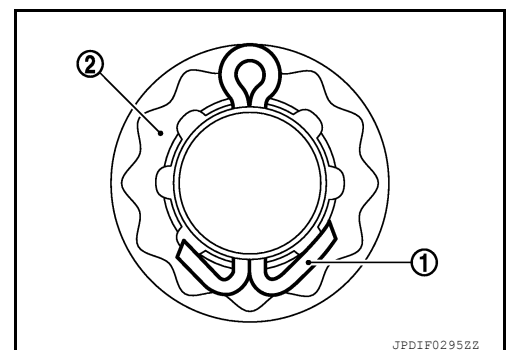

FRONT DRIVE SHAFT

< REMOVAL AND INSTALLATION >

- Align the matching marks (A) on the disc brake rotor and on the wheel hub and bearing.

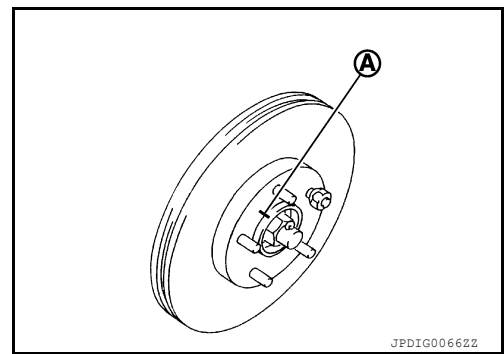

- Complete the inspection. Refer to [FAX-17, "Inspection"](#).

6M/T : Exploded View (RH)

INFOID:000000011538191

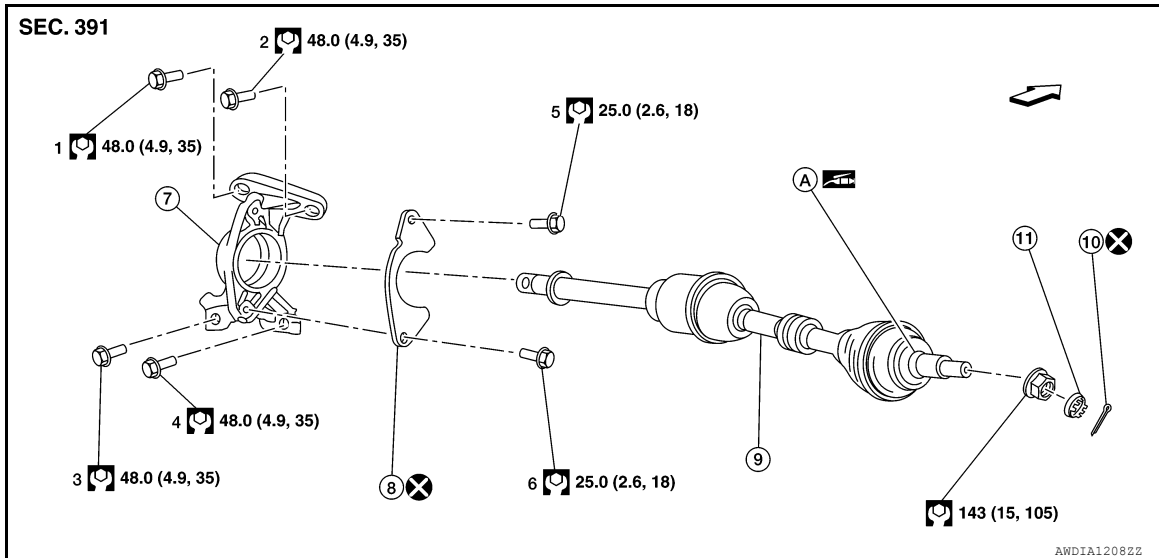

- | | | |
|-----------------------|----------------------------|----------------------------------|
| 1-6. Tightening order | 7. Support bearing bracket | 8. Support bearing bracket plate |
| 9. Front drive shaft | 10. Cotter pin | 11. Nut retainer |
| A. Molykote M77 | ⇐ Front | |

6M/T : Removal and Installation (RH)

INFOID:000000011538192

REMOVAL

- Remove the wheel and tire using power tool. Refer to [WT-47, "Exploded View"](#).
- Drain the M/T fluid. Refer to [TM-19, "Draining"](#).
- Remove the brake caliper torque member bolts, leaving the brake hose attached. Position the brake caliper aside with wire. Refer to [BR-39, "BRAKE CALIPER ASSEMBLY : Removal and Installation"](#).

CAUTION:

Do not depress the brake pedal while the brake caliper is removed.

FRONT DRIVE SHAFT

< REMOVAL AND INSTALLATION >

- Put alignment marks (A) on the disc brake rotor and on the wheel hub and bearing. Remove the disc brake rotor.

CAUTION:

Do not drop the disc brake rotor.

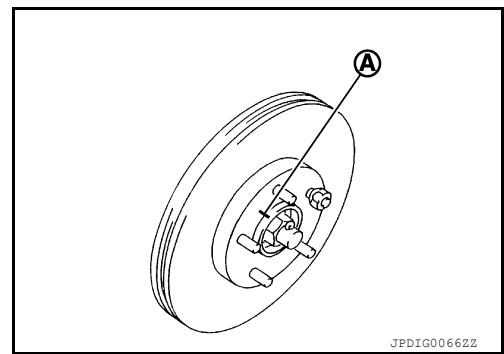

- Remove the wheel sensor bolt. Position the wheel sensor and the wheel sensor harness aside. Refer to [BRC-113, "FRONT WHEEL SENSOR : Removal and Installation"](#).
- Remove the cotter pin from the drive shaft.
- Remove the nut retainer from the wheel hub lock nut.
- Hold the wheel hub and bearing using Tool (A). Loosen the wheel hub lock nut.

Tool number

(A): KV40104000 (—)

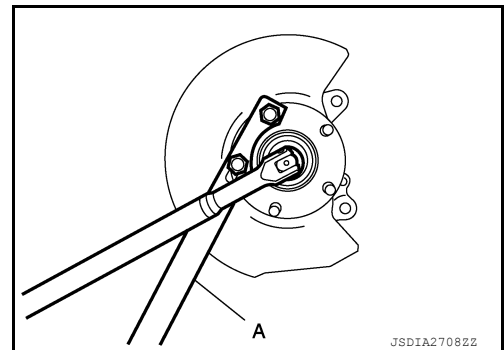

- Using a piece of wood and a suitable tool, tap on the wheel hub lock nut to disengage the drive shaft from the wheel hub and bearing.

CAUTION:

- Do not place the drive shaft joint at an extreme angle. Also be careful not to overextend slide joint.
- Do not allow the drive shaft to hang down without support.

NOTE:

Use a suitable puller if the drive shaft cannot be separated from the wheel hub and bearing even after performing the above procedure.

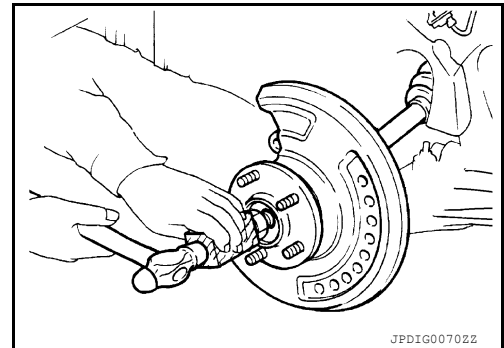

- Remove the wheel hub lock nut.
- Remove the bolts and the support bearing bracket plate.
- Remove the nut and bolt from the lower ball joint. Disconnect the steering knuckle from the transverse link.
- Remove the drive shaft from the wheel hub and bearing.
- Remove the drive shaft from the transaxle.
- Remove the differential side oil seal. Refer to [TM-20, "Removal and Installation"](#).
- If necessary, remove the support bearing bracket bolts and the support bearing bracket.
- Inspect the components. Refer to [FAX-24, "6M/T : Inspection"](#).

INSTALLATION

Installation is in the reverse order of removal.

TRANSAXLE SIDE

- Install a new differential side oil seal. Refer to [TM-20, "Removal and Installation"](#).

FRONT DRIVE SHAFT

< REMOVAL AND INSTALLATION >

- When installing the support bearing bracket (1), note the following:
 - Tighten the support bearing bracket bolts in 2 stages in the order of 1 to 4 as shown.
 - Install the support bearing bracket plate (2) with the notch (A) upward. Tighten the support bearing bracket plate bolts in 2 stages in the order of 1 to 2 as shown.

CAUTION:

Do not reuse the support bearing bracket plate.

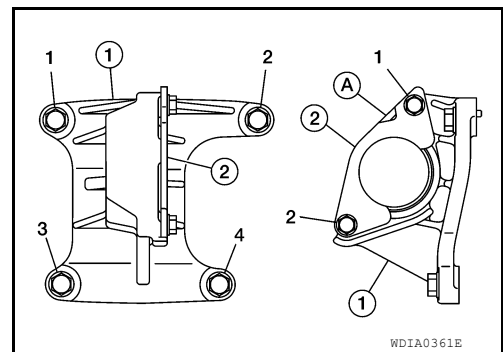

- Place Tool (A) onto the differential side oil seal to prevent damage to the oil seal while inserting the drive shaft. Slide drive shaft sliding joint and tap with a hammer to install securely.

Tool number (A): KV38107900 (—)

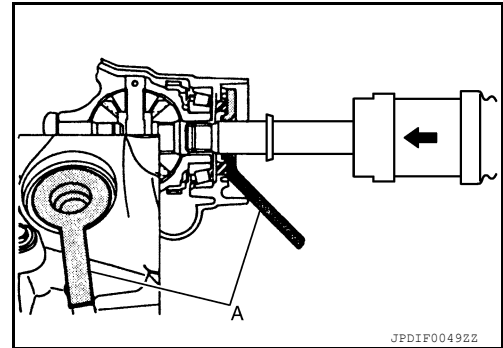

- Refill the M/T oil. Refer to [TM-19. "Refilling"](#).
- Complete the inspection. Refer to [FAX-17. "Inspection"](#).

WHEEL HUB SIDE

- Clean the mating surfaces of the wheel hub lock nut and the wheel hub and bearing.

CAUTION:

Do not apply lubricating oil to these mating surfaces.

- Clean the mating surfaces of the joint sub-assembly and the wheel hub and bearing. Apply Molykote M77 lubricant to the surface (A) of the joint sub-assembly.

CAUTION:

Apply lubricant to cover the entire flat mating surface of the joint sub-assembly.

NOTE:

Always check with the Parts Department for the latest parts information.

Amount of lubricant : Refer to [FAX-49. "Drive Shaft"](#).

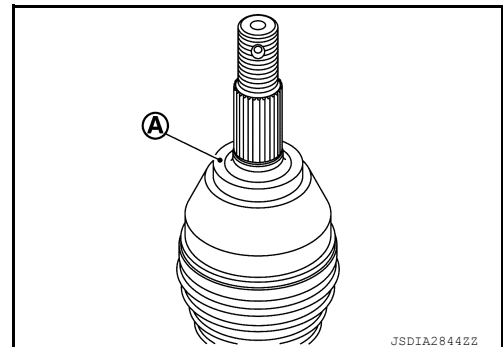

- Hold the wheel hub and bearing using Tool. Tighten the wheel hub lock nut.

CAUTION:

- **Since the drive shaft is assembled by press-fitting, use a torque wrench to tighten the wheel hub lock nut. Do not use a power tool.**
- **Too much torque causes axle noise. Too little torque causes wheel bearing looseness. Tighten the wheel hub lock nut to the specification.**

Tool number : KV40104000 (—)

FRONT DRIVE SHAFT

< REMOVAL AND INSTALLATION >

- When installing the cotter pin (1) and the nut retainer (2), securely bend the cotter pin to prevent rattles.

CAUTION:

Do not reuse the cotter pin.

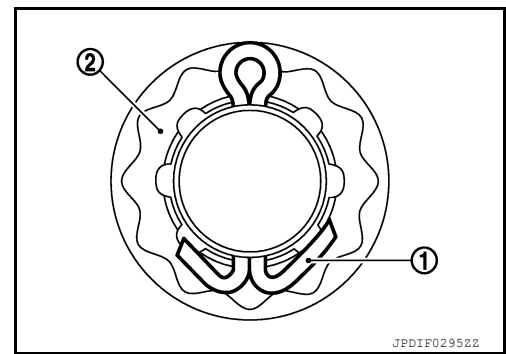

- Align the matching marks (A) on the disc brake rotor and on the wheel hub and bearing.

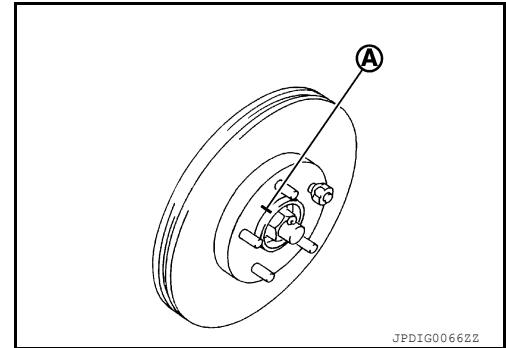

- Complete the inspection. Refer to [FAX-17. "Inspection"](#).

6M/T : Inspection

INFOID:000000011538193

INSPECTION AFTER REMOVAL

Check the following items and replace the part if necessary.

- Move the joint up/down, left/right, and in the axial directions. Check for motion that is not smooth and for significant looseness.
- Check the boot for cracks, damage, and grease leaks.
- Check the support bearing bracket for cracks, deformation, and other damage.

INSPECTION AFTER DISASSEMBLY

Check the following items and replace the part if necessary.

Shaft

Check the shaft for runout, cracks, or other damage. Replace the shaft if necessary.

Dynamic Damper

Check the dynamic damper for cracks or wear.

Joint Sub-Assembly

Check the following:

- Joint sub-assembly for rough rotation and excessive axial looseness.
 - The inside of the joint sub-assembly for entry of foreign material.
 - Joint sub-assembly for compression scars, cracks, and fractures inside of the joint sub-assembly.
- Replace the joint sub-assembly if there are any non-standard conditions of components.

Housing and spider assembly

Replace the housing and spider assembly if there is scratching or wear of the housing roller contact surface or the spider roller contact surface.

NOTE:

Replace the housing and spider assembly as a set.

Support Bearing (RH)

Verify the support bearing rolls freely and is free from noise, cracks, pitting or wear. Replace the support bearing if there are any non-standard conditions.

Support Bearing Bracket (RH)

FRONT DRIVE SHAFT

< REMOVAL AND INSTALLATION >

Check the support bearing bracket for cracks or damage. Replace the support bearing bracket if there are any non-standard conditions.

INSPECTION AFTER INSTALLATION

1. Check the wheel sensor harness to be sure the connectors are fully seated.
2. Check the wheel alignment. Refer to [FSU-6. "Inspection"](#).

EXCEPT 6M/T

EXCEPT 6M/T : Exploded View

INFOID:000000011538194

A
B
C

FAX

E
F
G
H
I
J
K
L
M
N
O
P

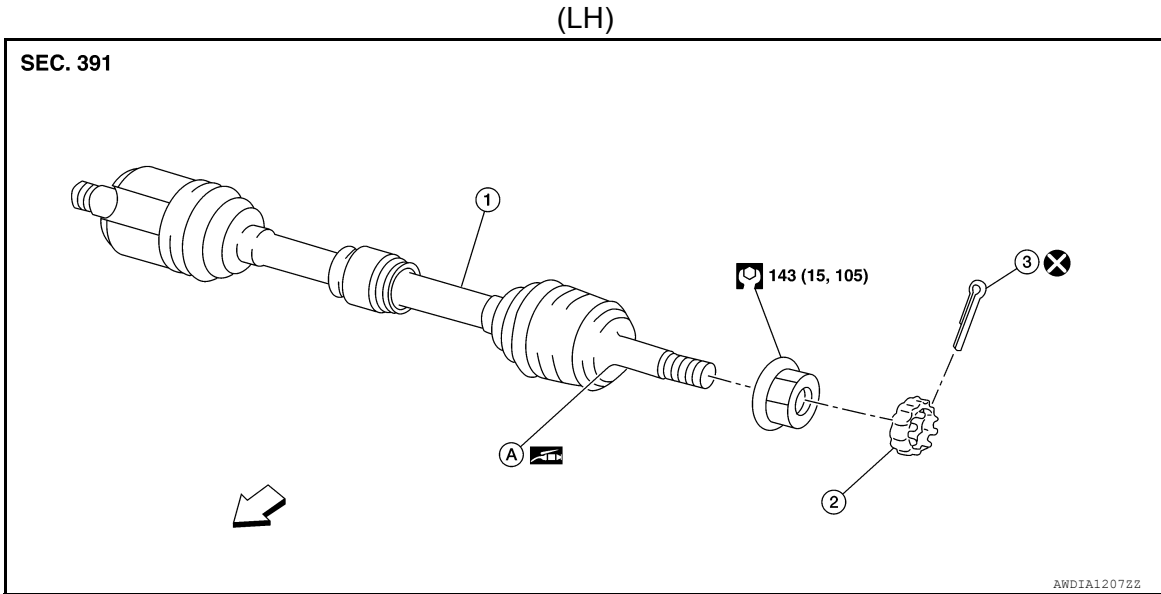

- | | | |
|----------------------|-----------------|---------------|
| 1. Front drive shaft | 2. Nut retainer | 3. Cotter pin |
| A. Molykote M77 | ↔ Front | |

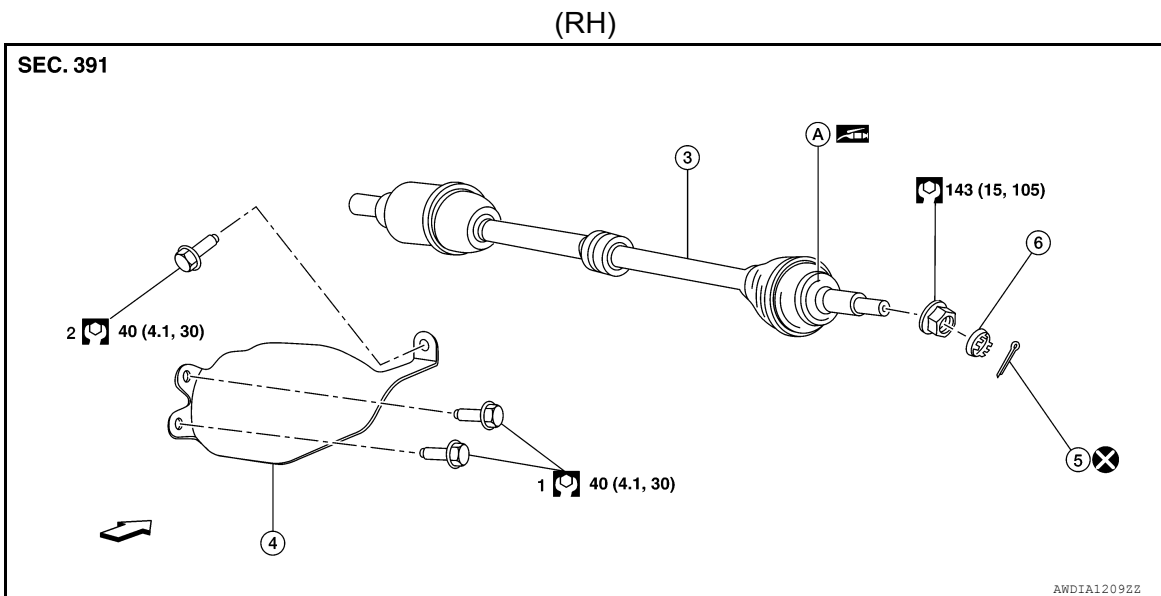

- | | | |
|----------------------|----------------------|-----------------|
| 1-2 Tightening order | 3. Front drive shaft | 4. Heat shield |
| 5. Cotter pin | 6. Nut retainer | A. Molykote M77 |
| ↔ Front | | |

FRONT DRIVE SHAFT

< REMOVAL AND INSTALLATION >

EXCEPT 6M/T : Removal and Installation

INFOID:000000011538195

NOTE:

When removing components such as hoses, tubes, lines, etc., cap or plug openings to prevent fluid from spilling.

REMOVAL

1. Remove the wheel and tire using power tool. Refer to [WT-47. "Exploded View"](#).
2. Remove the brake caliper torque member bolts, leaving the brake hose attached. Position the brake caliper aside with wire. Refer to [BR-39. "BRAKE CALIPER ASSEMBLY : Removal and Installation"](#).

CAUTION:

Do not depress the brake pedal while the brake caliper is removed.

3. Put alignment marks (A) on the disc brake rotor and on the wheel hub and bearing. Remove the disc brake rotor.

CAUTION:

Do not drop the disc brake rotor.

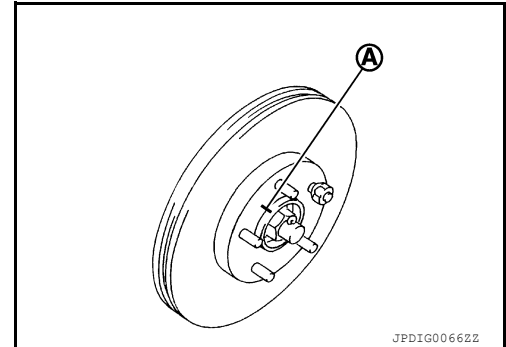

4. Remove the wheel sensor bolt. Position the wheel sensor and the wheel sensor harness aside. Refer to [BRC-113. "FRONT WHEEL SENSOR : Removal and Installation"](#).
5. Remove the cotter pin from the drive shaft.
6. Remove the nut retainer from the wheel hub lock nut.
7. Hold the wheel hub and bearing using Tool (A). Loosen the wheel hub lock nut.

Tool number

(A): KV40104000 (—)

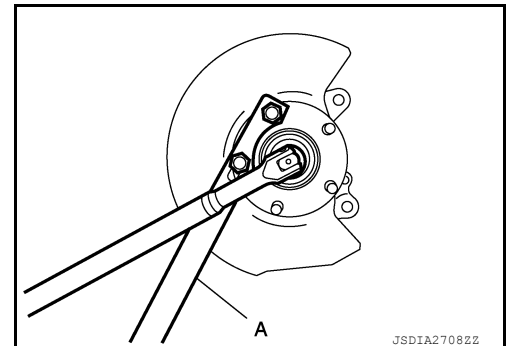

8. Using a piece of wood and a suitable tool, tap on the wheel hub lock nut to disengage the drive shaft from the wheel hub and bearing.

CAUTION:

- Do not place the drive shaft joint at an extreme angle. Also be careful not to overextend slide joint.
- Do not allow the drive shaft to hang down without support.

NOTE:

Use a suitable puller if the drive shaft cannot be separated from the wheel hub and bearing even after performing the above procedure.

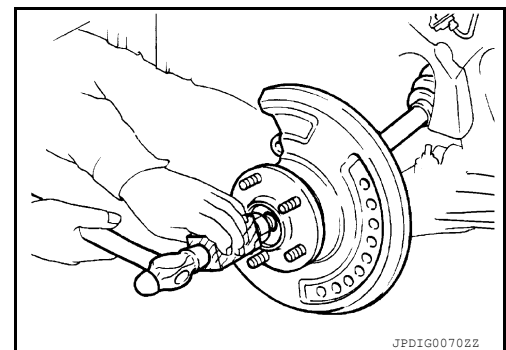

9. Remove the wheel hub lock nut.
10. Remove the nut and bolt from the lower ball joint. Disconnect the steering knuckle from the transverse link.
11. Remove the drive shaft from the wheel hub and bearing.
12. For the (RH) drive shaft, remove the bolts and the heat shield.

FRONT DRIVE SHAFT

< REMOVAL AND INSTALLATION >

13. Insert the Tool (A) between the shaft and the transaxle. Install a suitable tool (B) to the Tool (A). Remove the drive shaft from the transaxle.

CAUTION:

Confirm that the circular clip is attached to the drive shaft.

Tool number (A): KV40107500 (—)

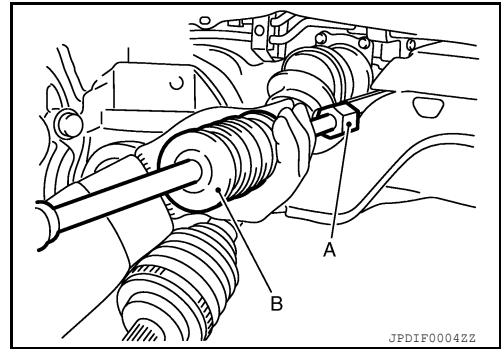

14. Remove the differential side oil seal. Refer to [TM-276, "Removal and Installation"](#).
15. Inspect the components. Refer to [FAX-28, "EXCEPT 6M/T : Inspection"](#).

INSTALLATION

Transaxle Side

Installation is in the reverse order of removal.

- Install a new differential side oil seal. Refer to [TM-276, "Removal and Installation"](#).

CAUTION:

Do not reuse the differential side oil seal.

- Place Tool (A) onto the differential side oil seal to prevent damage to the oil seal while inserting the drive shaft. Slide drive shaft sliding joint and tap with a hammer to install securely.

CAUTION:

Check that circular clip is completely engaged.

Tool number (A): KV38107900 (—)

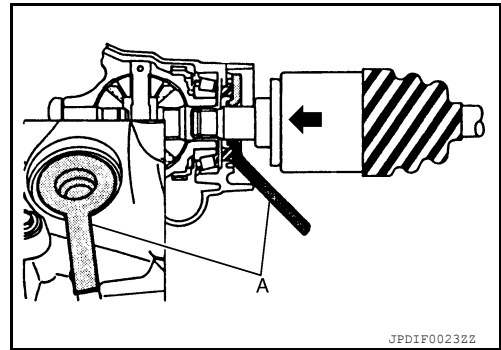

- Check the CVT fluid level. Check the CVT for leaks. Refer to [TM-253, "Inspection"](#).
- Complete the inspection. Refer to [FAX-17, "Inspection"](#).

Wheel Hub Side

- Clean the mating surfaces of the wheel hub lock nut and the wheel hub and bearing.

CAUTION:

Do not apply lubricating oil to these mating surfaces.

- Clean the mating surfaces of the joint sub-assembly and the wheel hub and bearing. Apply Molykote M77 lubricant to the surface (A) of the joint sub-assembly.

CAUTION:

Apply lubricant to cover the entire flat mating surface of the joint sub-assembly.

NOTE:

Always check with the Parts Department for the latest parts information.

Amount of lubricant : Refer to [FAX-49, "Drive Shaft"](#).

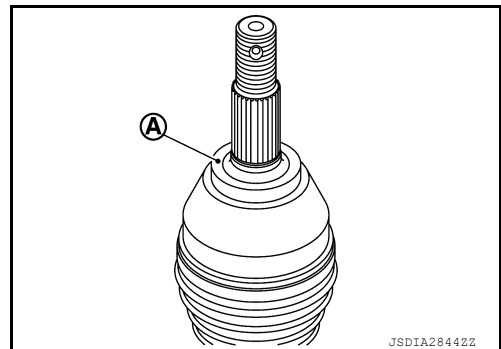

- Hold the wheel hub and bearing using Tool. Tighten the wheel hub lock nut.

CAUTION:

- Since the drive shaft is assembled by press-fitting, use a torque wrench to tighten the wheel hub lock nut. Do not use a power tool.

FRONT DRIVE SHAFT

< REMOVAL AND INSTALLATION >

- Too much torque causes axle noise. Too little torque causes wheel bearing looseness. Tighten the wheel hub lock nut to the specification.

Tool number : KV40104000 (—)

- When installing the cotter pin (1) and the nut retainer (2), securely bend the cotter pin to prevent rattles.

CAUTION:

Do not reuse the cotter pin.

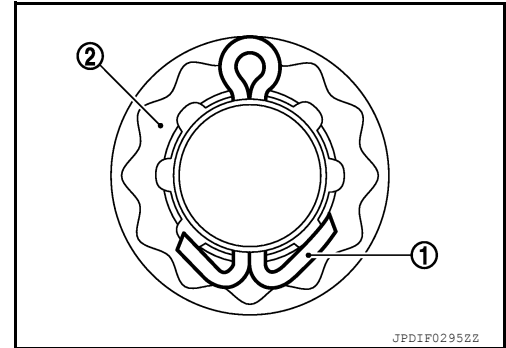

- Align the matching marks (A) on the disc brake rotor and on the wheel hub and bearing.

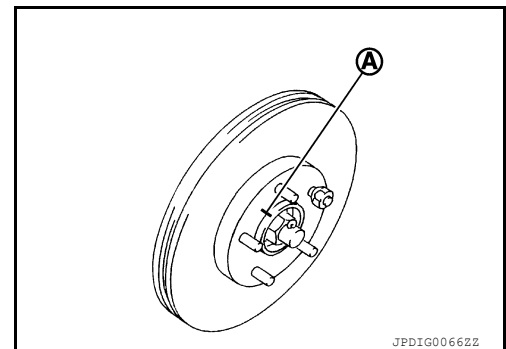

- Complete the inspection. Refer to [FAX-17. "Inspection"](#).

EXCEPT 6M/T : Inspection

INFOID:000000011538196

INSPECTION AFTER REMOVAL

Check the following items and replace the part if necessary.

- Move the joint up/down, left/right, and in the axial directions. Check for motion that is not smooth and for significant looseness.
- Check the boot for cracks, damage, and grease leaks.

INSPECTION AFTER DISASSEMBLY

Check the following items and replace the part if necessary.

Shaft

Check the shaft for runout, cracks, or other damage. Replace the shaft if necessary.

Dynamic Damper

Check the dynamic damper for cracks or wear.

Joint Sub-Assembly

Check the following:

- Joint sub-assembly for rough rotation and excessive axial looseness.
- The inside of the joint sub-assembly for entry of foreign material.
- Joint sub-assembly for compression scars, cracks, and fractures inside of the joint sub-assembly.

Replace the joint sub-assembly if there are any non-standard conditions of components.

Housing and spider assembly

Replace the housing and spider assembly if there is scratching or wear of the housing roller contact surface or the spider roller contact surface.

NOTE:

Replace the housing and spider assembly as a set.

INSPECTION AFTER INSTALLATION

FRONT DRIVE SHAFT

< REMOVAL AND INSTALLATION >

1. Check the wheel sensor harness to be sure the connectors are fully seated.
2. Check the wheel alignment. Refer to [FSU-6, "Inspection"](#).

A

B

C

FAX

E

F

G

H

I

J

K

L

M

N

O

P

FRONT DRIVE SHAFT

< UNIT DISASSEMBLY AND ASSEMBLY >

UNIT DISASSEMBLY AND ASSEMBLY

FRONT DRIVE SHAFT

6M/T

6M/T : Exploded View (LH)

INFOID:000000011538197

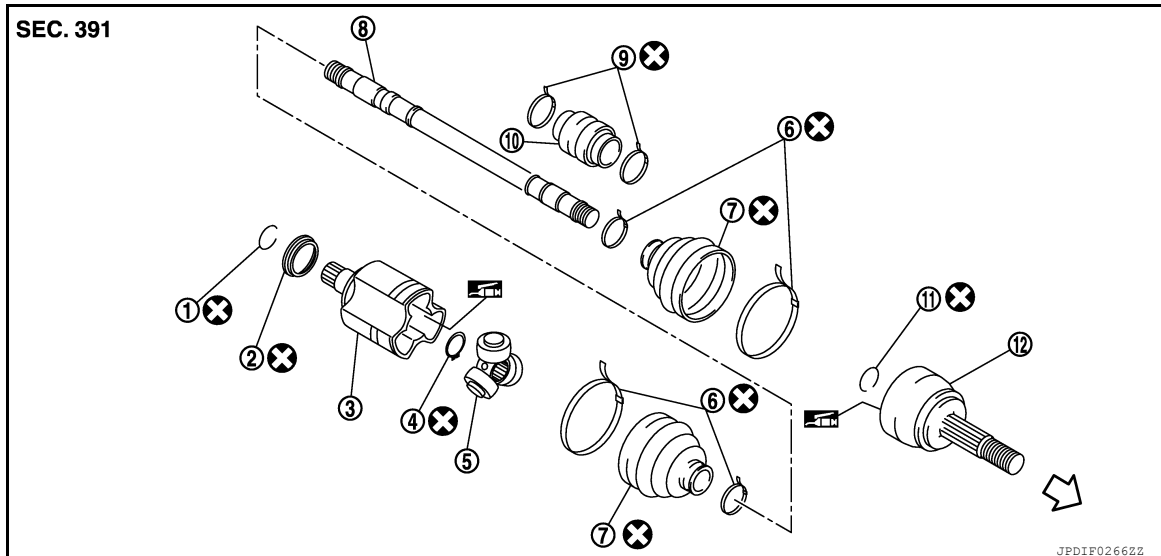

- | | | |
|--------------------|--------------------|------------------------|
| 1. Circular clip | 2. Dust shield | 3. Slide joint housing |
| 4. Snap ring | 5. Spider assembly | 6. Boot band |
| 7. Boot | 8. Shaft | 9. Damper band |
| 10. Dynamic damper | 11. Circular clip | 12. Joint sub-assembly |

⇐ Wheel side

6M/T : Disassembly and Assembly (LH)

INFOID:000000011538198

DISASSEMBLY (WHEEL SIDE)

1. Secure the drive shaft in a vise.

CAUTION:

When securing the drive shaft in a vise, always use aluminum or copper plates between the vise and the drive shaft.

2. Remove the boot bands and slide the boot back.
3. Screw a suitable tool (A) into the joint sub-assembly screw part to a length of 30 mm (1.18 in) or more. Support the drive shaft with one hand and pull out the joint sub-assembly from the shaft.

CAUTION:

- Align the suitable tool and the drive shaft. Remove the joint sub-assembly by pulling firmly and uniformly.
- If the joint sub-assembly cannot be removed after five or more attempts, replace the shaft and the joint sub-assembly as a set.

4. Remove the circular clip from the shaft.
5. Remove the outer boot from the shaft.
6. Inspect the components. Refer to [FAX-24. "6M/T : Inspection"](#).

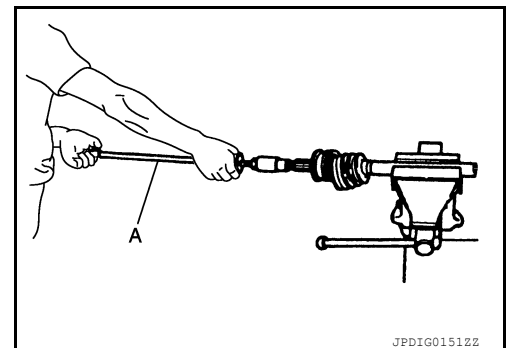

DISASSEMBLY (TRANSAXLE SIDE)

FRONT DRIVE SHAFT

< UNIT DISASSEMBLY AND ASSEMBLY >

1. Secure the drive shaft in a vise.

CAUTION:

When securing the drive shaft in a vise, always use aluminum or copper plates between the vise and the drive shaft.

2. Remove the boot bands and slide the boot back.
3. Put matching marks on the slide joint housing and on the shaft.

CAUTION:

Use paint or an equivalent for matching marks. Do not scratch the surfaces.

4. Remove the slide joint housing from the shaft.
5. Put matching marks (A) on the spider assembly and on the shaft.

CAUTION:

Use paint or an equivalent for matching marks. Do not scratch the surfaces.

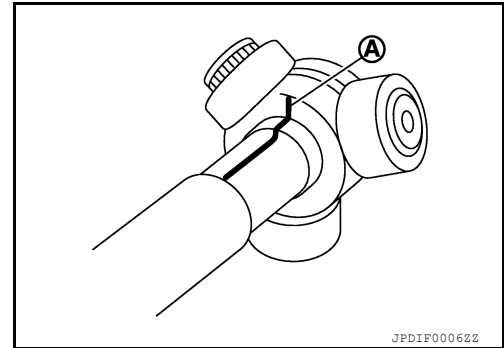

6. Remove the snap ring (1).
7. Remove the spider assembly from the shaft.
8. Remove the inner boot from the shaft.

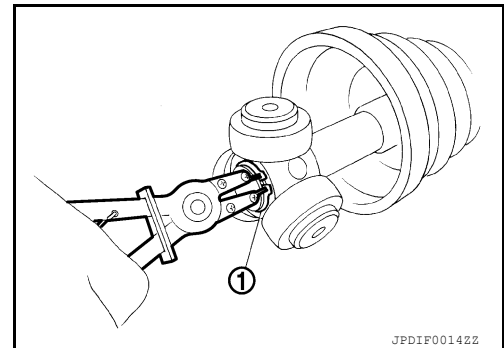

9. Remove the dust shield from the slide joint housing.
10. Remove the circular clip from the slide joint housing.
11. Clean the old grease from the slide joint housing with paper shop cloths.
12. Remove the damper bands.
13. Remove the dynamic damper from the shaft.
14. Inspect the components. Refer to [FAX-24. "6M/T : Inspection"](#).

ASSEMBLY (WHEEL SIDE)

1. Clean the old grease from the joint sub-assembly using paper shop cloths.
2. Fill the serration slot on the joint sub-assembly (1) with NISSAN genuine grease or equivalent until the serration slot and ball groove become full to the brim.

CAUTION:

After applying the grease, use paper shop cloths to wipe off the grease that has oozed out.

NOTE:

Always check with the Parts Department for the latest parts information.

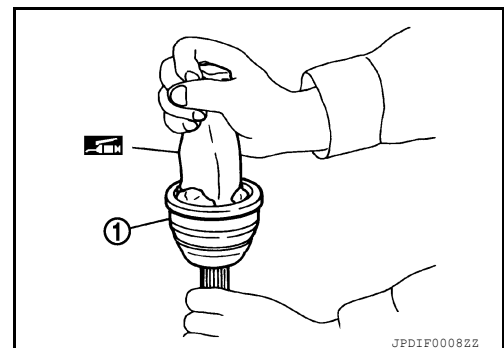

FRONT DRIVE SHAFT

< UNIT DISASSEMBLY AND ASSEMBLY >

3. Install the outer boot and the boot bands to the shaft.

CAUTION:

- Wrap the serration on the shaft with tape (A) to protect the boot from damage.
- Do not reuse the boot.
- Do not reuse the boot bands.

4. Remove the tape wrapped around the serration on the shaft.

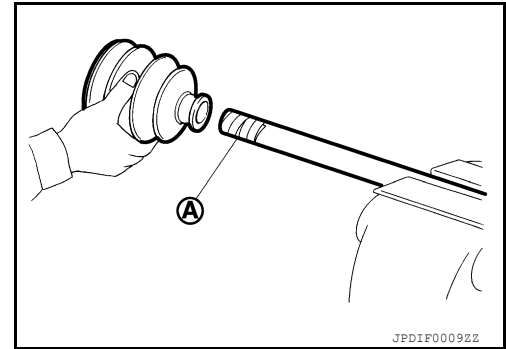

5. Position the circular clip (1) on the groove at the shaft edge.

CAUTION:

Do not reuse the circular clip.

NOTE:

A drive joint inserter is recommended when installing the circular clip.

6. Align both center axes with the shaft edge and the joint sub-assembly. Assemble the shaft with the joint sub-assembly while holding the circular clip.

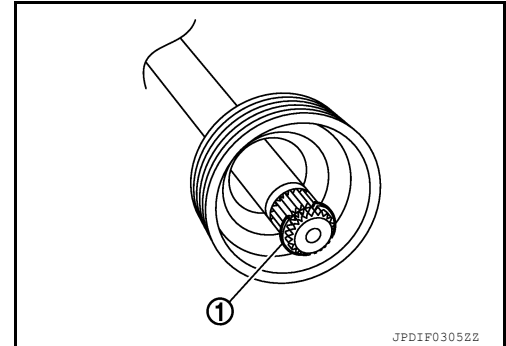

7. Install the joint sub-assembly to the shaft using a suitable tool.

CAUTION:

- Make sure the circular clip is properly positioned on the groove of the joint sub-assembly.
- Confirm that the joint sub-assembly is correctly engaged while rotating the drive shaft.

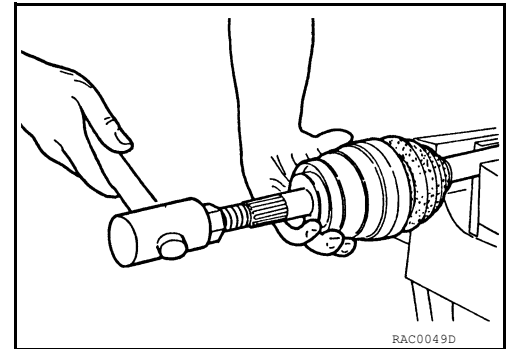

8. Apply the specified amount of grease to the inside of the large diameter side of the boot.

NOTE:

Always check with the Parts Department for the latest parts information.

Grease amount : Refer to [FAX-49, "Drive Shaft"](#).

9. Install the boot securely into the grooves (indicated by "*" marks) as shown.

CAUTION:

If there is grease on the boot mounting surfaces (indicated by "*" marks) on the shaft or the joint sub-assembly, the boot may come off. Remove all grease from the boot mounting surfaces.

10. To prevent the deformation of the boot, adjust the boot installation length to the specified value by inserting a suitable tool into the inside of the boot from the large diameter side of the boot and discharging the inside air.

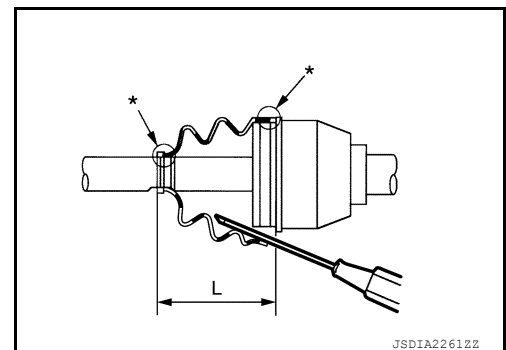

Boot installation length (L) : Refer to [FAX-49, "Drive Shaft"](#).

CAUTION:

- The boot may break if the boot installation length is not correct.
- Be careful not to touch the inside of the boot with the tip of the suitable tool.

FRONT DRIVE SHAFT

< UNIT DISASSEMBLY AND ASSEMBLY >

11. Install new large and small boot bands securely using Tool (A).

CAUTION:

Do not reuse the boot bands.

Tool number (A): KV40107300 (—)

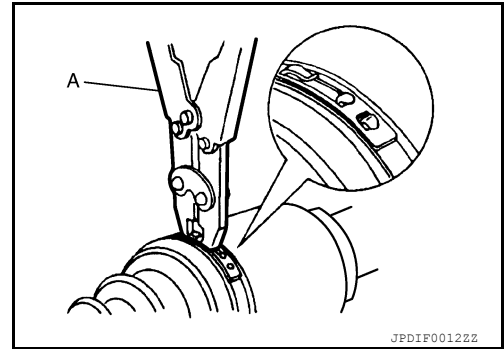

12. Secure the boot band so that dimension (A) meets the specification.

Dimension (A) : Refer to FAX-49, "Drive Shaft".

13. Attempt to rotate the boot to check whether or not the boot bands are securing the boot. If the boot is not secure, remove the boot bands, reposition the boot, and install new boot bands.

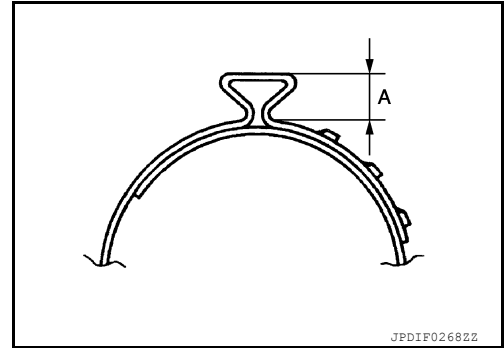

ASSEMBLY (TRANSAXLE SIDE)

1. Install the dynamic damper using the following procedure:

- Install the dynamic damper to the shaft.
- Secure the dynamic damper in the correct position with new damper bands.

CAUTION:

Do not reuse the damper bands.

Dimension (A) : Refer to FAX-49, "Drive Shaft".

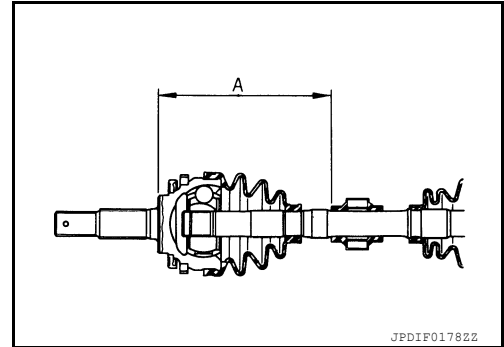

2. Install the inner boot and the boot bands to the shaft.

CAUTION:

- **Wrap the serration on the shaft with tape (A) to protect the boot from damage.**
- **Do not reuse the boot.**
- **Do not reuse the boot bands.**

3. Remove the tape wrapped around the serration on the shaft.

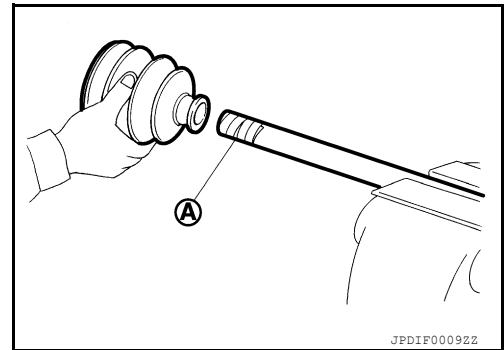

A
B
C
FAX
E
F
G
H
I
J
K
L
M
N
O
P

FRONT DRIVE SHAFT

< UNIT DISASSEMBLY AND ASSEMBLY >

4. Align the matching mark (A) on the spider assembly (1) with the matching mark on the shaft (2). Install the spider assembly to the shaft with the chamfer (B) facing the shaft.

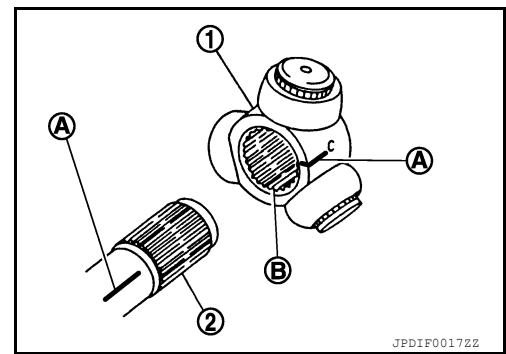

5. Secure the spider assembly onto the shaft with the snap ring (1).

CAUTION:

Do not reuse the snap ring.

6. Apply the appropriate amount of grease (Genuine NISSAN Grease or equivalent) to the spider assembly and to the sliding surface.

NOTE:

Always check with the Parts Department for the latest parts information.

7. Install the slide joint housing onto the spider assembly and pack the balance of the specified amount grease (Genuine NISSAN Grease or equivalent) into the slide joint housing.

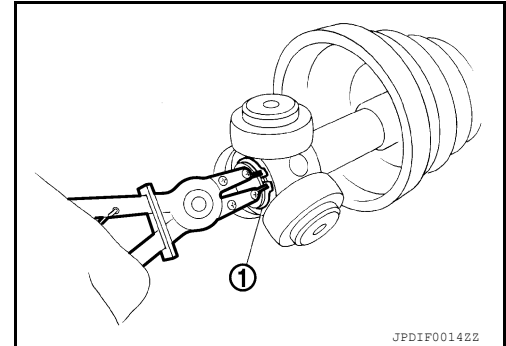

Grease amount : Refer to [FAX-49, "Drive Shaft"](#).

8. Align the matching marks on the slide joint housing and on the shaft.
9. Install the boot securely into the grooves (indicated by "*" marks) as shown.

CAUTION:

If there is grease on the boot mounting surfaces (indicated by "*" marks) on the shaft or the joint sub-assembly, the boot may come off. Remove all grease from the boot mounting surfaces.

10. To prevent the deformation of the boot, adjust the boot installation length to the specified value by inserting a suitable tool into the inside of the boot from the large diameter side of the boot and discharging the inside air.

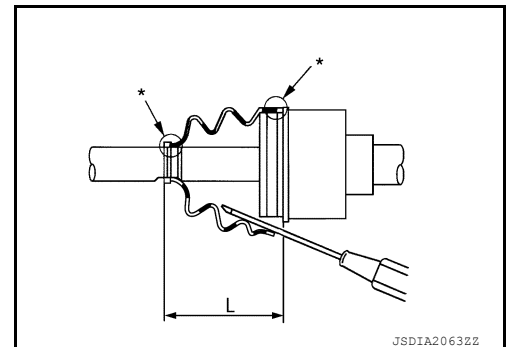

Boot installation length (L) : Refer to [FAX-49, "Drive Shaft"](#).

CAUTION:

- The boot may break if the boot installation length is not correct.
- Be careful not to touch the inside of the boot with the tip of the suitable tool.

11. Install the boot bands securely.

CAUTION:

Do not reuse the boot bands.

- a. Put boot band in the groove on drive shaft boot. Then fit pawls into holes to temporary installation.

NOTE:

FRONT DRIVE SHAFT

< UNIT DISASSEMBLY AND ASSEMBLY >

For the large diameter side, fit projection (A) and guide slit (B) at first.

b. Pinch projection on the band with suitable pliers to tighten band.

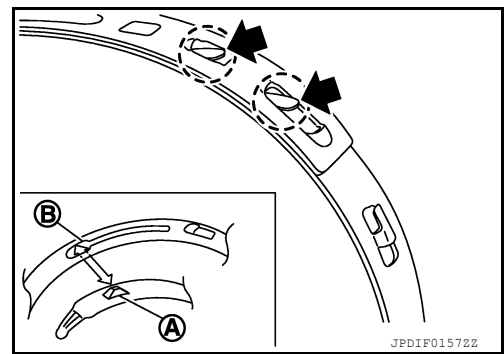

c. Insert the tip of band into the lower part of pawl (marked with dotted circle) as shown.

12. Attempt to rotate the boot to check whether or not the boot bands are securing the boot. If the boot is not secure, remove the boot bands, reposition the boot, and install new boot bands.

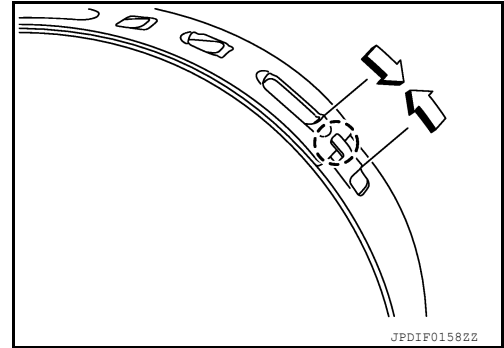

13. Install the dust shield to the slide joint housing.

CAUTION:

Do not reuse the dust shield.

14. Install the circular clip to the slide joint housing.

CAUTION:

Do not reuse the circular clip.

6M/T : Exploded View (RH)

INFOID:000000011538199

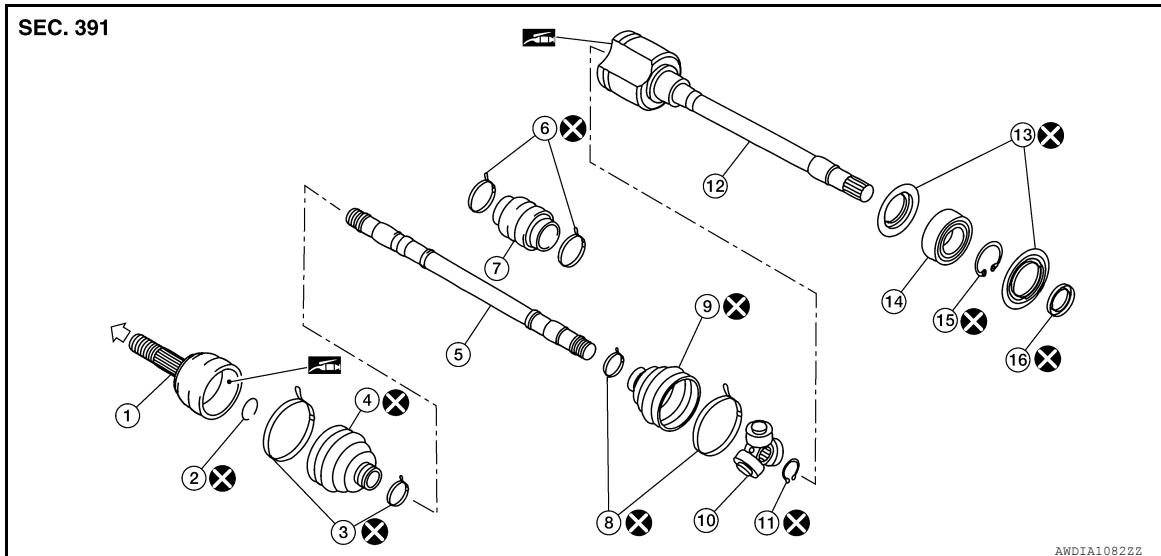

- 1. Joint sub-assembly
- 4. Boot
- 7. Dynamic damper
- 10. Spider assembly

- 2. Circular clip
- 5. Shaft
- 8. Boot band
- 11. Snap ring

- 3. Boot band
- 6. Damper band
- 9. Boot
- 12. Slide joint housing

FRONT DRIVE SHAFT

< UNIT DISASSEMBLY AND ASSEMBLY >

13. Dust shield

14. Support bearing

15. Snap ring

16. Dust shield

← Wheel side

6M/T : Disassembly and Assembly (RH)

INFOID:000000011538200

DISASSEMBLY (WHEEL SIDE)

1. Secure the drive shaft in a vise.

CAUTION:

When securing the drive shaft in a vise, always use aluminum or copper plates between the vise and the drive shaft.

2. Remove the boot bands and slide the boot back.
3. Screw a suitable tool (A) into the joint sub-assembly screw part to a length of 30 mm (1.18 in) or more. Support the drive shaft with one hand and pull out the joint sub-assembly from the shaft.

CAUTION:

- Align the suitable tool and the drive shaft. Remove the joint sub-assembly by pulling firmly and uniformly.
- If the joint sub-assembly cannot be removed after five or more attempts, replace the shaft and the joint sub-assembly as a set.

4. Remove the circular clip from the shaft.
5. Remove the outer boot from the shaft.
6. Inspect the components. Refer to [FAX-24. "6M/T : Inspection"](#).

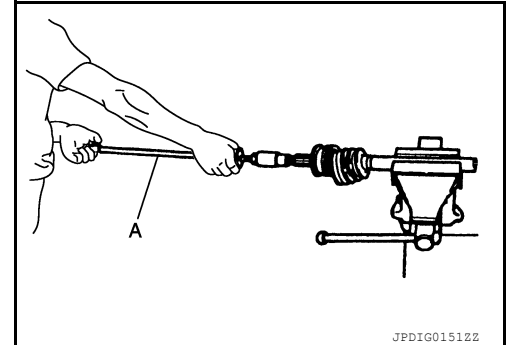

DISASSEMBLY (TRANSAXLE SIDE)

1. Secure the drive shaft in a vise.

CAUTION:

When securing the drive shaft in a vise, always use aluminum or copper plates between the vise and the drive shaft.

2. Remove the boot bands and slide the boot back.
3. Put matching marks on the slide joint housing and on the shaft.

CAUTION:

Use paint or an equivalent for matching marks. Do not scratch the surfaces.

4. Remove the slide joint housing from the shaft.
5. Put matching marks (A) on the spider assembly and on the shaft.

CAUTION:

Use paint or an equivalent for matching marks. Do not scratch the surfaces.

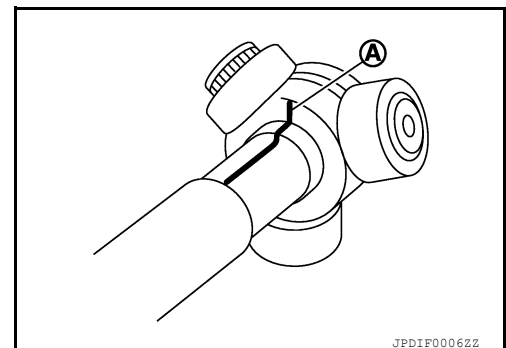

FRONT DRIVE SHAFT

< UNIT DISASSEMBLY AND ASSEMBLY >

6. Remove the snap ring (1).
7. Remove the spider assembly from the shaft.
8. Remove the inner boot from the shaft.

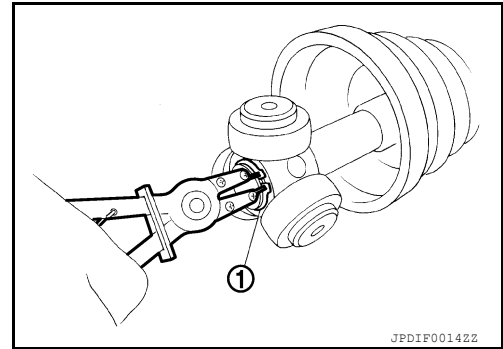

9. Remove the damper bands.
10. Remove the dynamic damper from the shaft.
11. Remove the support bearing using the following procedure:
 - a. Remove the dust shields from the slide joint housing.

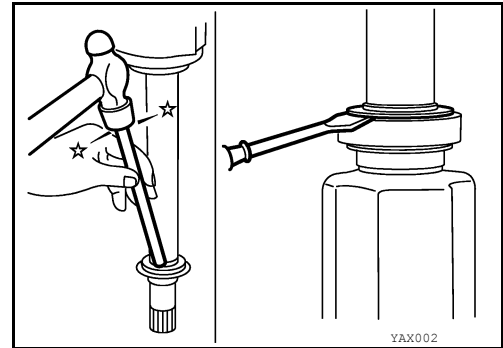

- b. Remove the snap ring (1).

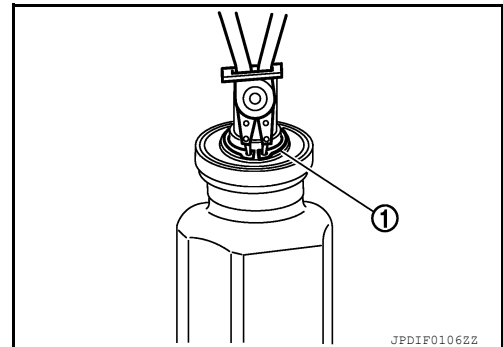

- c. Press out the support bearing from the slide joint housing.
 - d. Remove the dust shield from the slide joint housing.
 12. Clean the old grease from the slide joint housing with paper shop cloths.
 13. Inspect the components. Refer to [FAX-24, "6M/T : Inspection"](#).

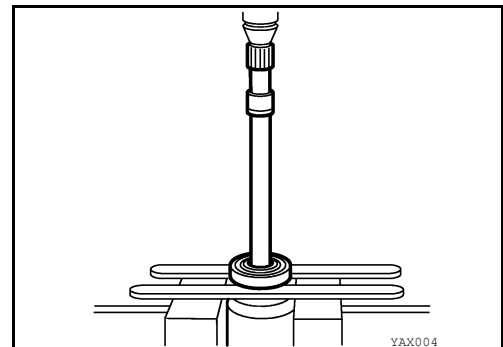

ASSEMBLY (WHEEL SIDE)

1. Clean the old grease from the joint sub-assembly using paper shop cloths.

A
B
C
FAX
E
F
G
H
I
J
K
L
M
N
O
P

FRONT DRIVE SHAFT

< UNIT DISASSEMBLY AND ASSEMBLY >

2. Fill the serration slot on the joint sub-assembly (1) with NISSAN genuine grease or equivalent until the serration slot and ball groove become full to the brim.

CAUTION:

After applying the grease, use paper shop cloths to wipe off the grease that has oozed out.

NOTE:

Always check with the Parts Department for the latest parts information.

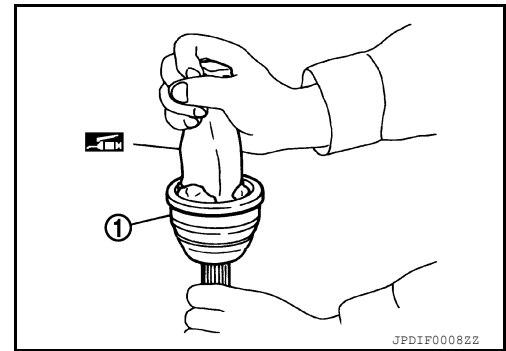

3. Install the outer boot and the boot bands to the shaft.

CAUTION:

- **Wrap the serration on the shaft with tape (A) to protect the boot from damage.**
- **Do not reuse the boot.**
- **Do not reuse the boot bands.**

4. Remove the tape wrapped around the serration on the shaft.

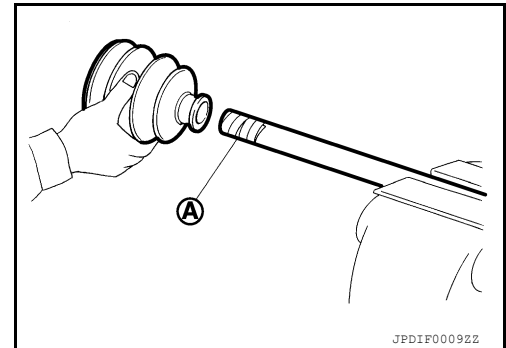

5. Position the circular clip (1) on the groove at the shaft edge.

CAUTION:

Do not reuse the circular clip.

NOTE:

A drive joint inserter is recommended when installing the circular clip.

6. Align both center axes with the shaft edge and the joint sub-assembly. Assemble the shaft with the joint sub-assembly while holding the circular clip.

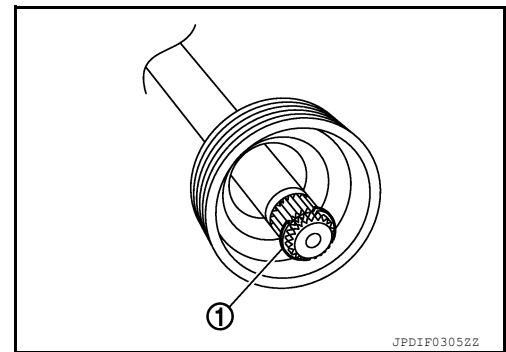

7. Install the joint sub-assembly to the shaft using a suitable tool.

CAUTION:

- **Make sure the circular clip is properly positioned on the groove of the joint sub-assembly.**
- **Confirm that the joint sub-assembly is correctly engaged while rotating the drive shaft.**

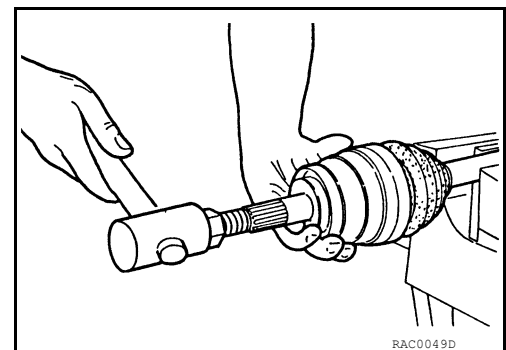

8. Apply the specified amount of grease to the inside of the large diameter side of the boot.

NOTE:

Always check with the Parts Department for the latest parts information.

Grease amount : Refer to [FAX-49, "Drive Shaft"](#).

FRONT DRIVE SHAFT

< UNIT DISASSEMBLY AND ASSEMBLY >

9. Install the boot securely into the grooves (indicated by "*" marks) as shown.

CAUTION:

If there is grease on the boot mounting surfaces (indicated by "*" marks) on the shaft or the joint sub-assembly, the boot may come off. Remove all grease from the boot mounting surfaces.

10. To prevent the deformation of the boot, adjust the boot installation length to the specified value by inserting a suitable tool into the inside of the boot from the large diameter side of the boot and discharging the inside air.

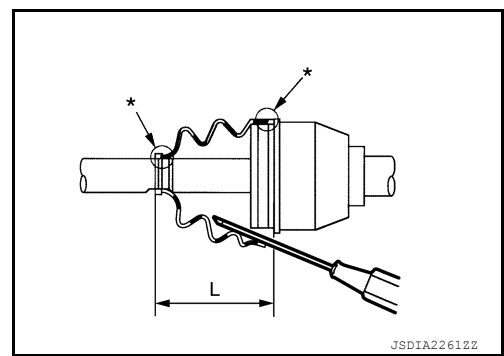

JSDIA2261ZZ

Boot installation length (L) : Refer to FAX-49, "Drive Shaft".

CAUTION:

- The boot may break if the boot installation length is not correct.
- Be careful not to touch the inside of the boot with the tip of the suitable tool.

11. Install new large and small boot bands securely using Tool (A).

CAUTION:

Do not reuse the boot bands.

Tool number (A): KV40107300 (—)

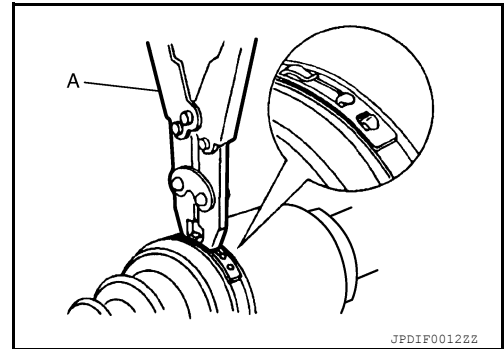

JPDIF0012ZZ

12. Secure the boot band so that dimension (A) meets the specification.

Dimension (A) : Refer to FAX-49, "Drive Shaft".

13. Attempt to rotate the boot to check whether or not the boot bands are securing the boot. If the boot is not secure, remove the boot bands, reposition the boot, and install new boot bands.

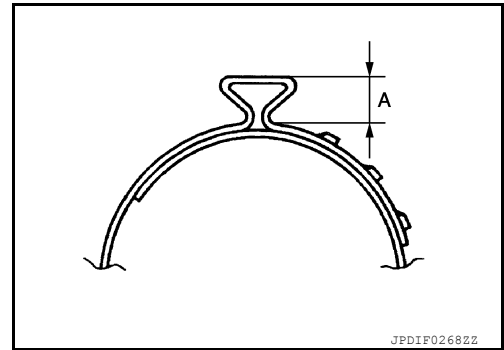

JPDIF0268ZZ

ASSEMBLY (TRANSAXLE SIDE)

1. Install the support bearing using the following procedure:

- a. Install the dust shield to the slide joint housing.

CAUTION:

Do not reuse the dust shield.

- b. Press the support bearing (1) onto the slide joint housing using the suitable tool (A).

CAUTION:

Do not reuse the support bearing.

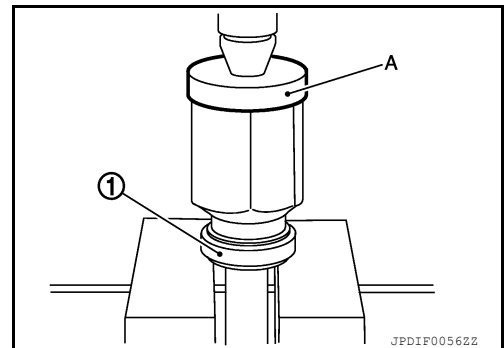

JPDIF0056ZZ

FRONT DRIVE SHAFT

< UNIT DISASSEMBLY AND ASSEMBLY >

- c. Install the snap ring (1).

CAUTION:

Do not reuse the snap ring.

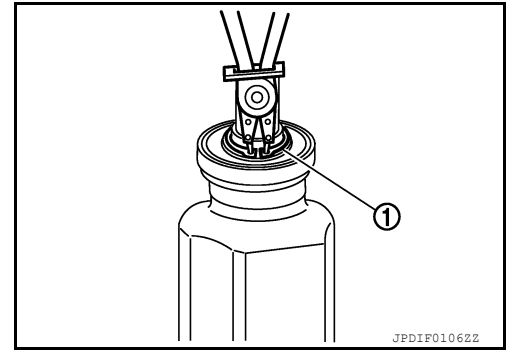

- d. Install the dust shields.

CAUTION:

Do not reuse the dust shield.

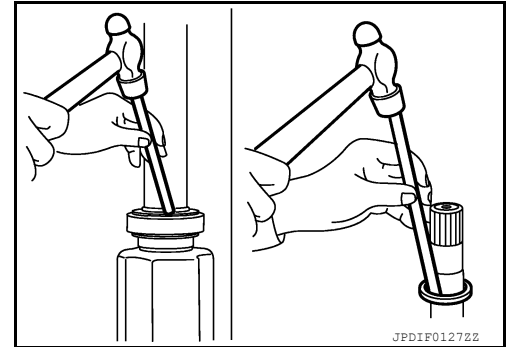

2. Install the dynamic damper using the following procedure:

- a. Install the dynamic damper to the shaft.

- b. Secure the dynamic damper in the correct position with new damper bands.

CAUTION:

Do not reuse the damper bands.

Dimension (A) : Refer to [FAX-49, "Drive Shaft"](#).

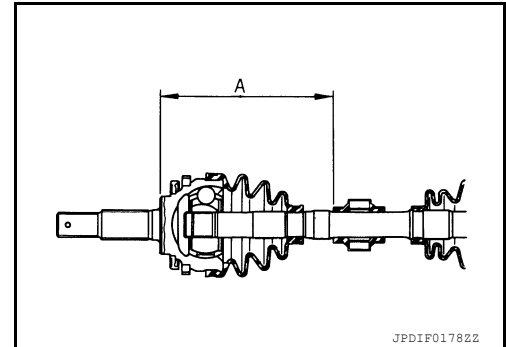

3. Install the inner boot and the boot bands to the shaft.

CAUTION:

- Wrap the serration on the shaft with tape (A) to protect the boot from damage.
- Do not reuse the boot.
- Do not reuse the boot bands.

4. Remove the tape wrapped around the serration on the shaft.

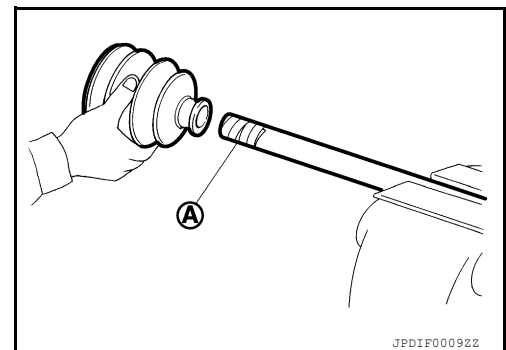

FRONT DRIVE SHAFT

< UNIT DISASSEMBLY AND ASSEMBLY >

5. Align the matching mark (A) on the spider assembly (1) with the matching mark on the shaft (2). Install the spider assembly to the shaft with the chamfer (B) facing the shaft.

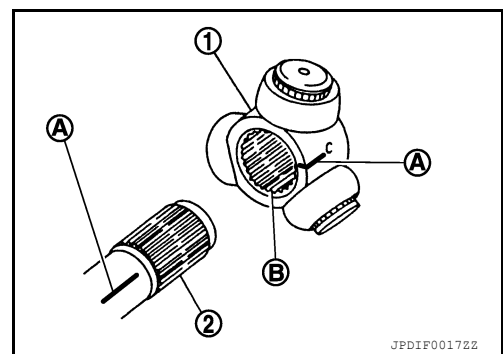

6. Secure the spider assembly onto the shaft with the snap ring (1).

CAUTION:

Do not reuse the snap ring.

7. Apply the appropriate amount of grease (Genuine NISSAN Grease or equivalent) to the spider assembly and to the sliding surface.

NOTE:

Always check with the Parts Department for the latest parts information.

8. Install the slide joint housing onto the spider assembly and pack the balance of the specified amount grease (Genuine NISSAN Grease or equivalent) into the slide joint housing.

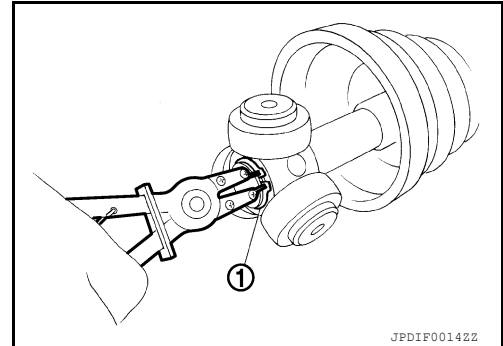

Grease amount : Refer to [FAX-49, "Drive Shaft"](#).

9. Align the matching marks on the slide joint housing and on the shaft.
10. Install the boot securely into the grooves (indicated by "*" marks) as shown.

CAUTION:

If there is grease on the boot mounting surfaces (indicated by "*" marks) on the shaft or the joint sub-assembly, the boot may come off. Remove all grease from the boot mounting surfaces.

11. To prevent the deformation of the boot, adjust the boot installation length to the specified value by inserting a suitable tool into the inside of the boot from the large diameter side of the boot and discharging the inside air.

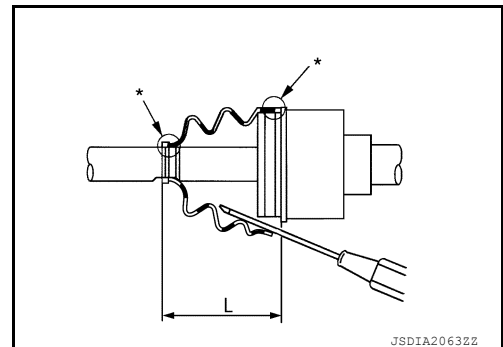

Boot installation length (L) : Refer to [FAX-49, "Drive Shaft"](#).

CAUTION:

- The boot may break if the boot installation length is not correct.
- Be careful not to touch the inside of the boot with the tip of the suitable tool.

12. Install the boot bands securely.

CAUTION:

Do not reuse the boot bands.

- a. Put boot band in the groove on drive shaft boot. Then fit pawls into holes to temporary installation.

NOTE:

FRONT DRIVE SHAFT

< UNIT DISASSEMBLY AND ASSEMBLY >

For the large diameter side, fit projection (A) and guide slit (B) at first.

b. Pinch projection on the band with suitable pliers to tighten band.

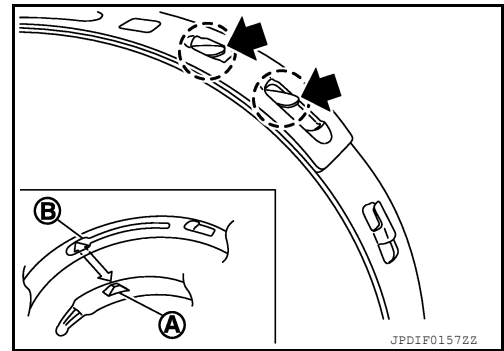

c. Insert the tip of band into the lower part of pawl (marked with dotted circle) as shown.

13. Attempt to rotate the boot to check whether or not the boot bands are securing the boot. If the boot is not secure, remove the boot bands, reposition the boot, and install new boot bands.

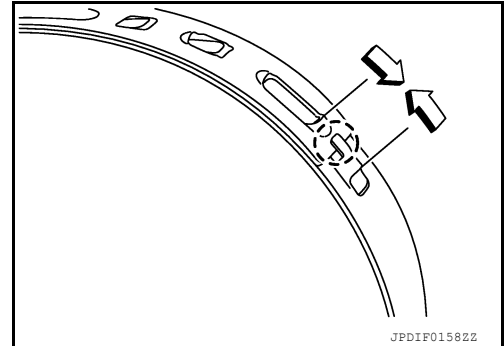

EXCEPT 6M/T

EXCEPT 6M/T : Exploded View

INFOID:000000011538201

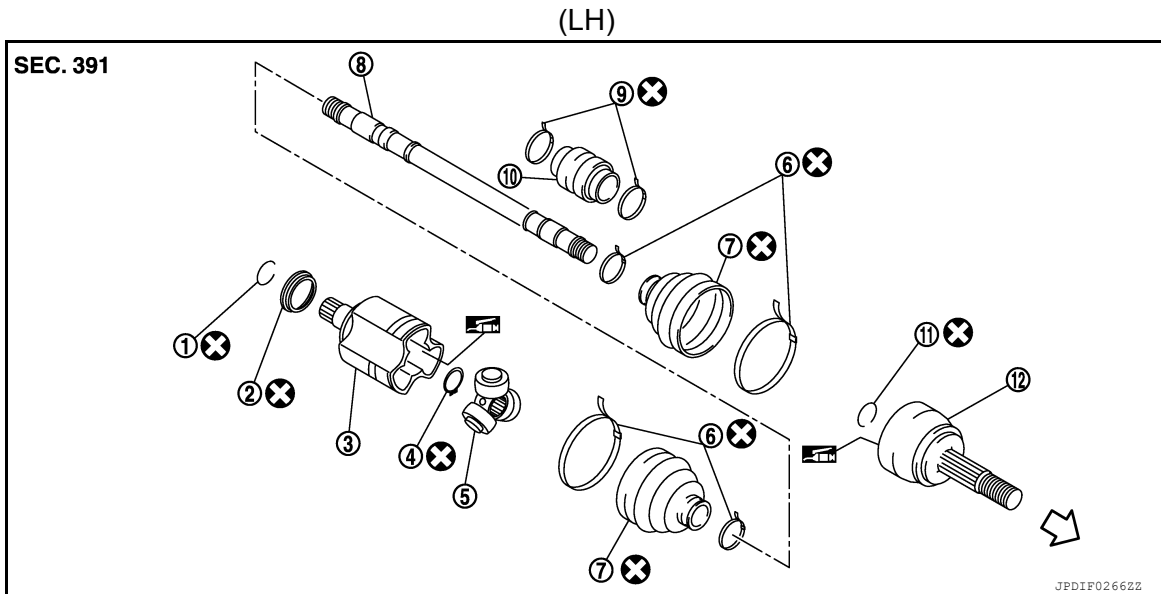

- | | | |
|--------------------|--------------------|------------------------|
| 1. Circular clip | 2. Dust shield | 3. Slide joint housing |
| 4. Snap ring | 5. Spider assembly | 6. Boot band |
| 7. Boot | 8. Shaft | 9. Damper band |
| 10. Dynamic damper | 11. Circular clip | 12. Joint sub-assembly |
- ↶ Wheel side

FRONT DRIVE SHAFT

< UNIT DISASSEMBLY AND ASSEMBLY >

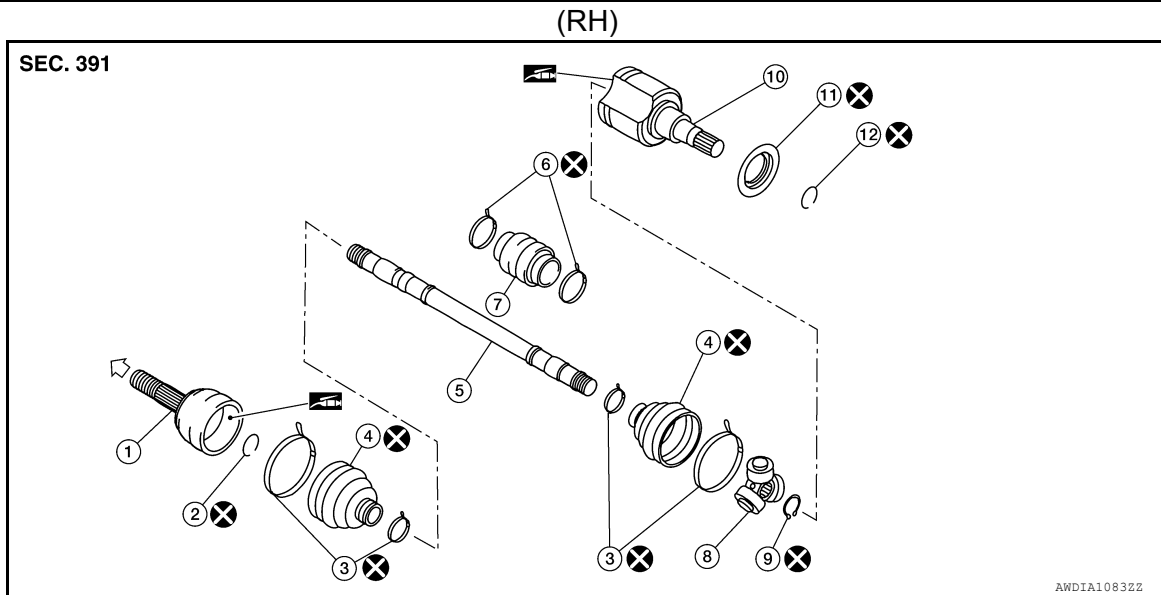

- | | | |
|-------------------------|--------------------|-------------------|
| 1. Joint sub-assembly | 2. Circular clip | 3. Boot band |
| 4. Boot | 5. Shaft | 6. Damper band |
| 7. Dynamic damper | 8. Spider assembly | 9. Snap ring |
| 10. Slide joint housing | 11. Dust shield | 12. Circular clip |

⇐ Wheel side

EXCEPT 6M/T : Disassembly and Assembly

INFOID:000000011538202

DISASSEMBLY (WHEEL SIDE)

1. Secure the drive shaft in a vise.

CAUTION:

When securing the drive shaft in a vise, always use aluminum or copper plates between the vise and the drive shaft.

2. Remove the boot bands and slide the boot back.
3. Screw a suitable tool (A) into the joint sub-assembly screw part to a length of 30 mm (1.18 in) or more. Support the drive shaft with one hand and pull out the joint sub-assembly from the shaft.

CAUTION:

- Align the suitable tool and the drive shaft. Remove the joint sub-assembly by pulling firmly and uniformly.
- If the joint sub-assembly cannot be removed after five or more attempts, replace the shaft and the joint sub-assembly as a set.

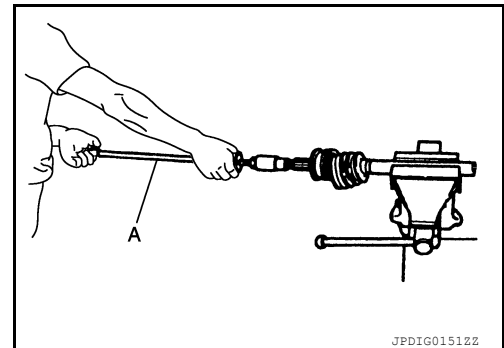

4. Remove the circular clip from the shaft.
5. Remove the outer boot from the shaft.
6. Inspect the components. Refer to [FAX-28, "EXCEPT 6M/T : Inspection"](#).

DISASSEMBLY (TRANSAXLE SIDE)

1. Secure the drive shaft in a vise.

CAUTION:

When securing the drive shaft in a vise, always use aluminum or copper plates between the vise and the drive shaft.

2. Remove the boot bands and slide the boot back.
3. Put matching marks on the slide joint housing and on the shaft.

CAUTION:

Use paint or an equivalent for matching marks. Do not scratch the surfaces.

FRONT DRIVE SHAFT

< UNIT DISASSEMBLY AND ASSEMBLY >

4. Remove the slide joint housing from the shaft.
5. Put matching marks (A) on the spider assembly and on the shaft.

CAUTION:

Use paint or an equivalent for matching marks. Do not scratch the surfaces.

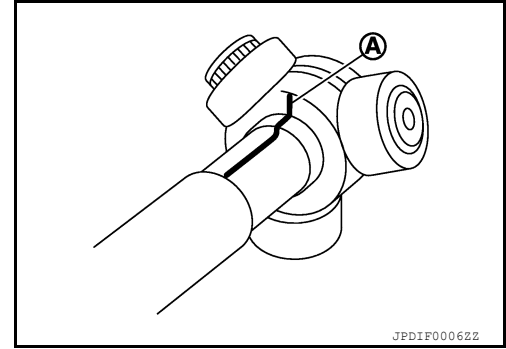

6. Remove the snap ring (1).
7. Remove the spider assembly from the shaft.
8. Remove the inner boot from the shaft.

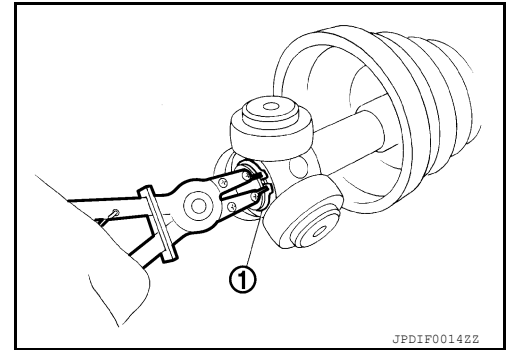

9. Remove the dust shield from the slide joint housing.
10. Remove the circular clip from the slide joint housing.
11. Clean the old grease from the slide joint housing with paper shop cloths.
12. Remove the damper bands.
13. Remove the dynamic damper from the shaft.
14. Inspect the components. Refer to [FAX-28, "EXCEPT 6M/T : Inspection"](#).

ASSEMBLY (WHEEL SIDE)

1. Clean the old grease from the joint sub-assembly using paper shop cloths.
2. Fill the serration slot on the joint sub-assembly (1) with NISSAN genuine grease or equivalent until the serration slot and ball groove become full to the brim.

CAUTION:

After applying the grease, use paper shop cloths to wipe off the grease that has oozed out.

NOTE:

Always check with the Parts Department for the latest parts information.

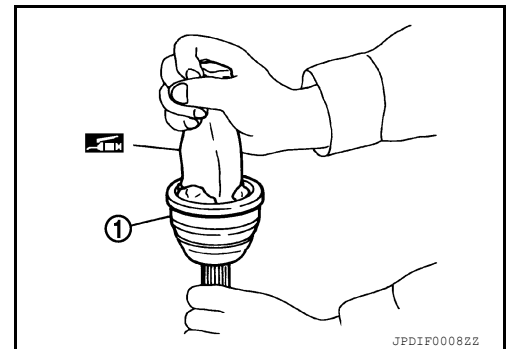

3. Install the outer boot and the boot bands to the shaft.

CAUTION:

- Wrap the serration on the shaft with tape (A) to protect the boot from damage.
- Do not reuse the boot.
- Do not reuse the boot bands.

4. Remove the tape wrapped around the serration on the shaft.

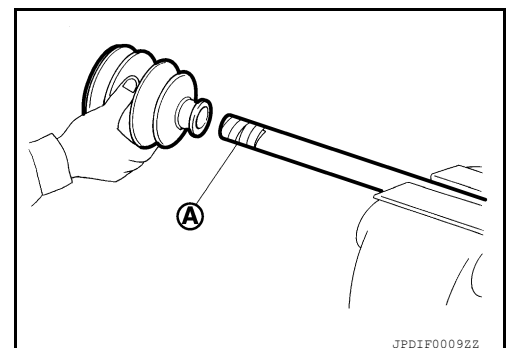

FRONT DRIVE SHAFT

< UNIT DISASSEMBLY AND ASSEMBLY >

5. Position the circular clip (1) on the groove at the shaft edge.

CAUTION:

Do not reuse the circular clip.

NOTE:

A drive joint inserter is recommended when installing the circular clip.

6. Align both center axes with the shaft edge and the joint sub-assembly. Assemble the shaft with the joint sub-assembly while holding the circular clip.

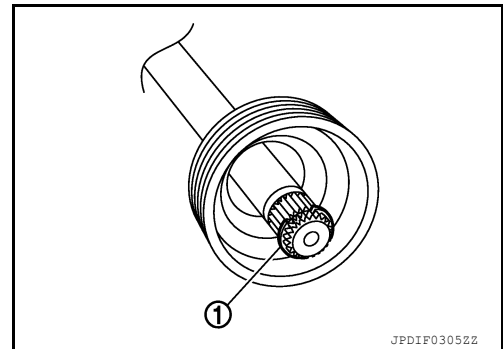

7. Install the joint sub-assembly to the shaft using a suitable tool.

CAUTION:

- **Make sure the circular clip is properly positioned on the groove of the joint sub-assembly.**
- **Confirm that the joint sub-assembly is correctly engaged while rotating the drive shaft.**

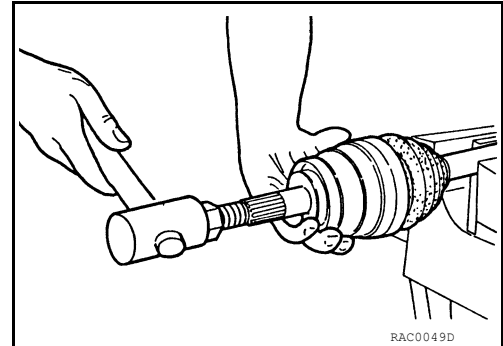

8. Apply the specified amount of grease to the inside of the large diameter side of the boot.

NOTE:

Always check with the Part Department for the latest parts information.

Grease amount : Refer to [FAX-49, "Drive Shaft"](#).

9. Install the boot securely into the grooves (indicated by "*" marks) as shown.

CAUTION:

If there is grease on the boot mounting surfaces (indicated by "*" marks) on the shaft or the joint sub-assembly, the boot may come off. Remove all grease from the boot mounting surfaces.

10. To prevent the deformation of the boot, adjust the boot installation length to the specified value by inserting a suitable tool into the inside of the boot from the large diameter side of the boot and discharging the inside air.

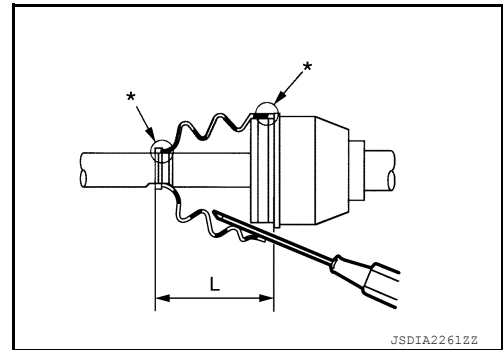

Boot installation length (L) : Refer to [FAX-49, "Drive Shaft"](#).

CAUTION:

- **The boot may break if the boot installation length is not correct.**
- **Be careful not to touch the inside of the boot with the tip of the suitable tool.**

11. Install new large and small boot bands securely using Tool (A).

CAUTION:

Do not reuse the boot bands.

Tool number (A): KV40107300 (—)

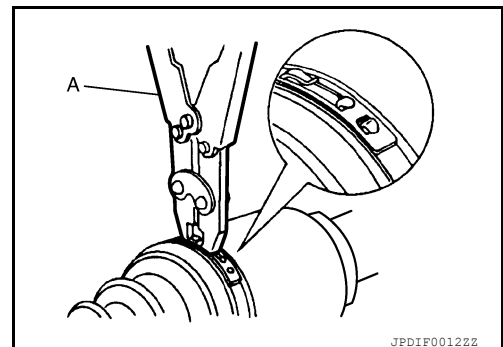

FRONT DRIVE SHAFT

< UNIT DISASSEMBLY AND ASSEMBLY >

12. Secure the boot band so that dimension (A) meets the specification.

Dimension (A) : Refer to [FAX-49, "Drive Shaft"](#).

13. Attempt to rotate the boot to check whether or not the boot bands are securing the boot. If the boot is not secure, remove the boot bands, reposition the boot, and install new boot bands.

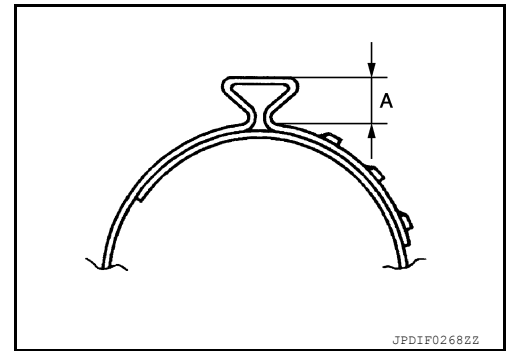

ASSEMBLY (TRANSAXLE SIDE)

1. Install the dynamic damper using the following procedure:
 - a. Install the dynamic damper to the shaft.
 - b. Secure the dynamic damper in the correct position with new damper bands.

CAUTION:

Do not reuse damper bands.

Dimension (A) : Refer to [FAX-49, "Drive Shaft"](#).

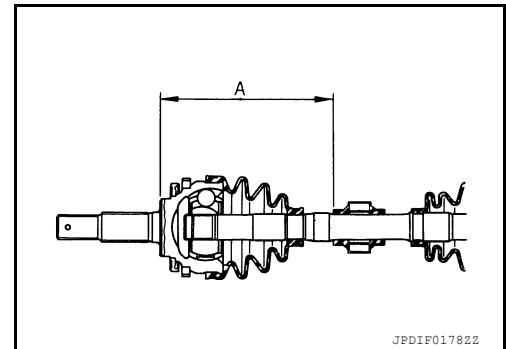

2. Install the inner boot and the boot bands to the shaft.

CAUTION:

- Wrap the serration on the shaft with tape (A) to protect the boot from damage.
- Do not reuse the boot.
- Do not reuse the boot bands.

3. Remove the tape wrapped around the serration on the shaft.

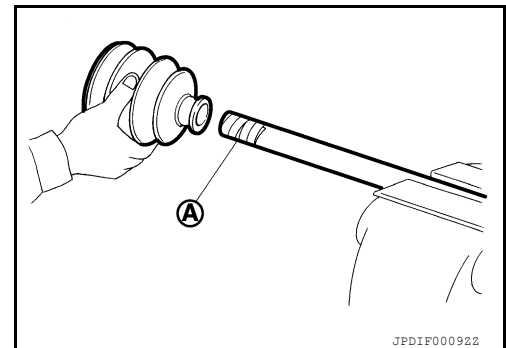

4. Align the matching mark (A) on the spider assembly (1) with the matching mark on the shaft (2). Install the spider assembly to the shaft with the chamfer (B) facing the shaft.

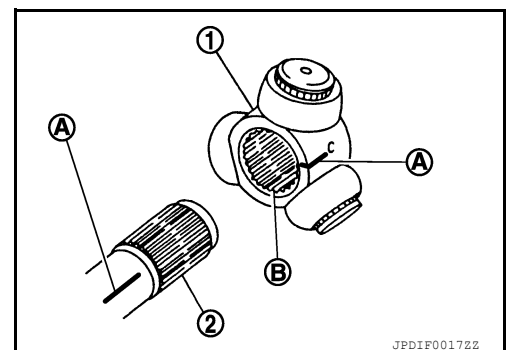

FRONT DRIVE SHAFT

< UNIT DISASSEMBLY AND ASSEMBLY >

- Secure the spider assembly onto the shaft with the snap ring (1).

CAUTION:

Do not reuse the snap ring.

- Apply the appropriate amount of grease (Genuine NISSAN Grease or equivalent) to the spider assembly and to the sliding surface.

NOTE:

Always check with the Parts Department for the latest parts information.

- Install the slide joint housing onto the spider assembly and pack the balance of the specified amount grease (Genuine NISSAN Grease or equivalent) into the slide joint housing.

NOTE:

Always check with the Parts Department for the latest parts information.

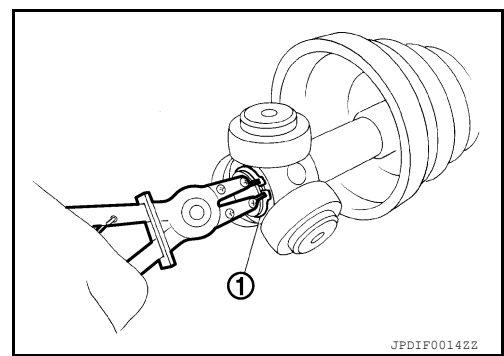

Grease amount : Refer to [FAX-49, "Drive Shaft"](#).

- Align the matching marks on the slide joint housing and on the shaft.

- Install the boot securely into the grooves (indicated by "*" marks) as shown.

CAUTION:

If there is grease on the boot mounting surfaces (indicated by "*" marks) on the shaft or the joint sub-assembly, the boot may come off. Remove all grease from the boot mounting surfaces.

- To prevent the deformation of the boot, adjust the boot installation length to the specified value by inserting a suitable tool into the inside of the boot from the large diameter side of the boot and discharging the inside air.

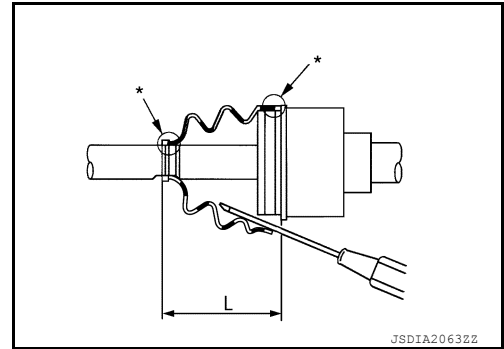

Boot installation length (L) : Refer to [FAX-49, "Drive Shaft"](#).

CAUTION:

- The boot may break if the boot installation length is not correct.
- Be careful not to touch the inside of the boot with the tip of the suitable tool.

- Install the boot bands securely.

CAUTION:

Do not reuse the boot bands.

For low profile type band

- Put the new boot band in the groove on the drive shaft boot. Temporarily fit the pawls into the holes.

NOTE:

For the large diameter side, fit the projection (A) into the guide slit (B).

- Pinch the projection on the band with suitable pliers to tighten the band.

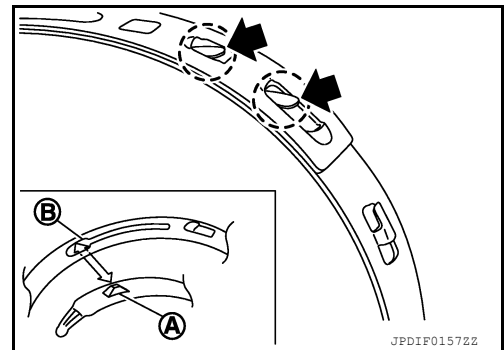

FRONT DRIVE SHAFT

< UNIT DISASSEMBLY AND ASSEMBLY >

3. Insert the tip of the band into the lower part of the pawl (marked with dotted circle) as shown.

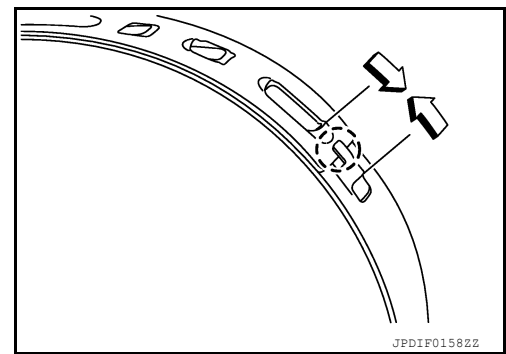

For omega type band

1. Install new large and small boot bands securely using Tool (A).

CAUTION:

Do not reuse the boot bands.

Tool number (A): KV40107300 (—)

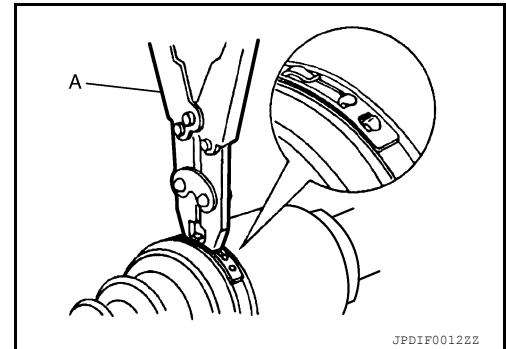

2. Secure the boot band so that dimension (A) meets the specification.

Dimension (A) : Refer to [FAX-49, "Drive Shaft"](#).

12. Attempt to rotate the boot to check whether or not the boot bands are securing the boot. If the boot is not secure, remove the boot bands, reposition the boot, and install new boot bands.

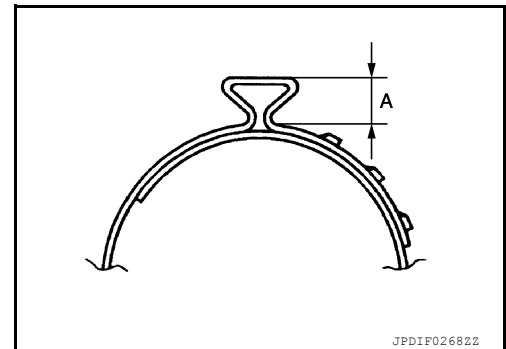

13. Install the dust shield to the slide joint housing.

CAUTION:

Do not reuse the dust shield.

14. Install the circular clip to the slide joint housing.

CAUTION:

Do not reuse the circular clip.

SERVICE DATA AND SPECIFICATIONS (SDS)

< SERVICE DATA AND SPECIFICATIONS (SDS)

SERVICE DATA AND SPECIFICATIONS (SDS)

SERVICE DATA AND SPECIFICATIONS (SDS)

Wheel Bearing

INFOID:0000000011538203

Item	Standard
Axial end play	0.05 mm (0.002 in) or less

Drive Shaft

INFOID:0000000011538204

Drive Shaft Specifications

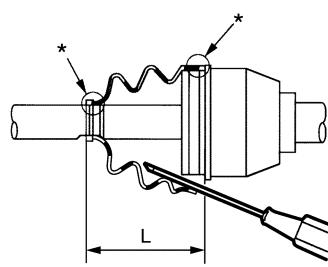

JSDIA2261ZZ

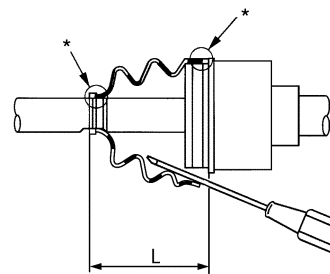

JSDIA2063ZZ

Application	M/T			
Joint type	Wheel side		Transaxle side	
	(LH)	(RH)	(LH)	(RH)
Grease amount*	105 - 125 g (3.70 - 4.41 oz)		130 - 140 g (4.59 - 4.94 oz)	
Molykote M77 lubricant*	1.0 - 3.0 g (0.04 - 0.11 oz)			
Boot installed length (L)	94.8 mm (3.732 in)		93.3 mm (3.673 in)	
Application	CVT			
Joint type	Wheel side		Transaxle side	
	(LH)	(RH)	(LH)	(RH)
Grease amount*	70 - 90 g (2.47 - 3.17 oz)		130 - 140 g (4.59 - 4.94 oz)	
Molykote M77 lubricant*	1.0 - 3.0 g (0.04 - 0.11 oz)			
Boot installed length (L)	94.7 mm (3.728 in)		93.3 mm (3.673 in)	

*: Always check with the Parts Department for the latest parts information.

Dynamic Damper Specifications

A
B
C
FAX
E
F
G
H
I
J
K
L
M
N
O
P

SERVICE DATA AND SPECIFICATIONS (SDS)

< SERVICE DATA AND SPECIFICATIONS (SDS)

Unit: mm (in)

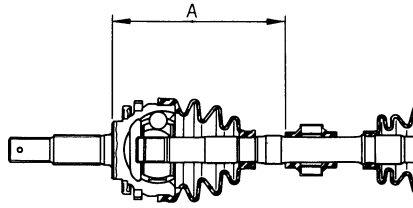

JPDIF0178ZZ

Application	M/T		CVT	
	(LH)	(RH)	(LH)	(RH)
Dimension (A)	237 - 243 mm (9.33 - 9.57 in)		222 - 228 mm (8.74 - 8.98 in)	502 - 508 mm (19.76 - 20.00 in)

Boot Band Specification

Unit: mm (in)

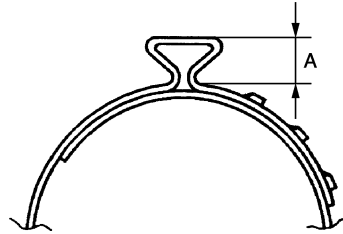

JPDIF0268ZZ

Dimension (A) - maximum	7.0 mm (0.276 in)
-------------------------	-------------------