

SECTION **FSU**
FRONT SUSPENSION

A
B
C
D

FSU

CONTENTS

PRECAUTION	2	Removal and Installation	10	F
PRECAUTIONS	2	Inspection	10	
Precaution for Supplemental Restraint System (SRS) "AIR BAG" and "SEAT BELT PRE-TENSIONER"	2	FRONT STABILIZER	12	G
Precaution for Procedure without Cowl Top Cover.....	2	Exploded View	12	
Precautions for Suspension	2	Removal and Installation	12	
PREPARATION	3	Inspection	13	H
PREPARATION	3	STEERING KNUCKLE	14	
Special Service Tools	3	Exploded View	14	I
Commercial Service Tools	3	Removal and Installation	14	
SYMPTOM DIAGNOSIS	4	Inspection	15	J
NOISE, VIBRATION AND HARSHNESS (NVH) TROUBLESHOOTING	4	UNIT REMOVAL AND INSTALLATION	16	
NVH Troubleshooting Chart	4	FRONT SUSPENSION MEMBER	16	K
PERIODIC MAINTENANCE	5	Exploded View	16	
FRONT SUSPENSION ASSEMBLY	5	Removal and Installation	16	
Inspection	5	Inspection	18	
WHEEL ALIGNMENT	6	UNIT DISASSEMBLY AND ASSEMBLY ...	19	L
Inspection	6	FRONT COIL SPRING AND STRUT	19	
Adjustment	7	Exploded View	19	M
REMOVAL AND INSTALLATION	8	Disassembly and Assembly	19	
FRONT COIL SPRING AND STRUT	8	Inspection	21	
Exploded View	8	Disposal	22	
Removal and Installation	8	SERVICE DATA AND SPECIFICATIONS (SDS)	23	N
TRANSVERSE LINK	10	SERVICE DATA AND SPECIFICATIONS (SDS)	23	O
Exploded View	10	Wheel Alignment (Unladen*1)	23	
		Ball Joint	23	P
		Wheelarch Height (Unladen*)	23	

PRECAUTIONS

< PRECAUTION >

PRECAUTION

PRECAUTIONS

Precaution for Supplemental Restraint System (SRS) "AIR BAG" and "SEAT BELT PRE-TENSIONER"

INFOID:000000011539043

The Supplemental Restraint System such as "AIR BAG" and "SEAT BELT PRE-TENSIONER", used along with a front seat belt, helps to reduce the risk or severity of injury to the driver and front passenger for certain types of collision. Information necessary to service the system safely is included in the SR and SB section of this Service Manual.

WARNING:

- To avoid rendering the SRS inoperative, which could increase the risk of personal injury or death in the event of a collision which would result in air bag inflation, all maintenance must be performed by an authorized NISSAN/INFINITI dealer.
- Improper maintenance, including incorrect removal and installation of the SRS, can lead to personal injury caused by unintentional activation of the system. For removal of Spiral Cable and Air Bag Module, see the SR section.
- Do not use electrical test equipment on any circuit related to the SRS unless instructed to in this Service Manual. SRS wiring harnesses can be identified by yellow and/or orange harnesses or harness connectors.

PRECAUTIONS WHEN USING POWER TOOLS (AIR OR ELECTRIC) AND HAMMERS

WARNING:

- When working near the Airbag Diagnosis Sensor Unit or other Airbag System sensors with the Ignition ON or engine running, DO NOT use air or electric power tools or strike near the sensor(s) with a hammer. Heavy vibration could activate the sensor(s) and deploy the air bag(s), possibly causing serious injury.
- When using air or electric power tools or hammers, always switch the Ignition OFF, disconnect the battery and wait at least three minutes before performing any service.

Precaution for Procedure without Cowl Top Cover

INFOID:000000011539044

When performing the procedure after removing cowl top cover, cover the lower end of windshield with urethane, etc to prevent damage to windshield.

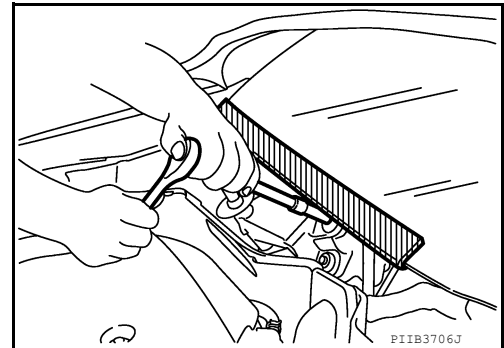

Precautions for Suspension

INFOID:000000011539045

- When installing rubber bushings, the final tightening must be carried out under unladen conditions with tires on ground. Spilled oil might shorten the life of rubber bushings. Be sure to wipe off any spilled oil.
- Unladen conditions mean that fuel, engine coolant and lubricant are full. Spare tire, jack, hand tools and mats are in designated positions.
- After servicing suspension parts, be sure to check wheel alignment.
- Self-lock nuts are not reusable. Always use new ones when installing. Since new self-lock nuts are pre-oiled, tighten as they are.
- The tightening surface must be kept free from oil/grease.
- When jacking up the vehicle with a floor jack, do not hang the jack on the torque rod.

PREPARATION

< PREPARATION >

PREPARATION

PREPARATION

Special Service Tools

INFOID:000000011539046

The actual shape of the tools may differ from those illustrated here.

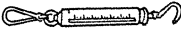
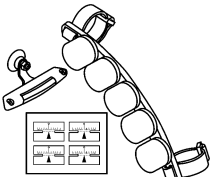
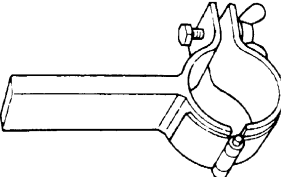
Tool number (TechMate No.) Tool name	Description
— (J-44372) Pull Gauge  LST024	Measuring ball joint swinging force
— (J-49286) Drift and pull gauge  AWEIA01562Z	Measuring drift and pull
ST35652000 (—) Strut attachment  ZZA0807D	Disassembling and assembling strut

A

B

C

D

FSU

F

G

H

I

J

Commercial Service Tools

INFOID:000000011539047

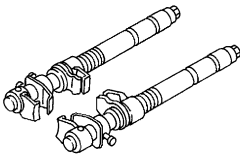
Tool name	Description
Power tool  PIIB1407E	Loosening nuts, screws and bolts
Spring compressor  S-NT717	Removing and installing coil spring

L

M

N

O

P

NOISE, VIBRATION AND HARSHNESS (NVH) TROUBLESHOOTING

< SYMPTOM DIAGNOSIS >

SYMPTOM DIAGNOSIS

NOISE, VIBRATION AND HARSHNESS (NVH) TROUBLESHOOTING

NVH Troubleshooting Chart

INFOID:0000000011539048

Use chart below to find the cause of the symptom. If necessary, repair or replace these parts.

Symptom		Possible cause and SUSPECTED PARTS	Reference														
			FSU-8, FSU-10, FSU-12, FSU-16	FSU-21	—	—	FSU-21	FSU-8, FSU-10, FSU-12, FSU-16	FSU-6	FSU-13	FAX-5, "NVH Troubleshooting Chart"	WT-45, "NVH Troubleshooting Chart"	WT-45, "NVH Troubleshooting Chart"	FAX-5, "NVH Troubleshooting Chart"	BR-7, "NVH Troubleshooting Chart"	ST-9, "NVH Troubleshooting Chart"	
Symptom	FRONT SUSPENSION	Noise	x	x	x	x	x	x			x	x	x	x	x	x	x
		Shake	x	x	x	x		x			x	x	x	x	x	x	x
		Vibration	x	x	x	x	x				x	x		x			
		Shimmy	x	x	x	x			x		x	x	x		x	x	
		Shudder	x	x	x						x	x	x		x	x	
		Poor quality ride or handling	x	x	x	x	x		x	x	x	x	x				

x: Applicable

FRONT SUSPENSION ASSEMBLY

< PERIODIC MAINTENANCE >

PERIODIC MAINTENANCE

FRONT SUSPENSION ASSEMBLY

Inspection

INFOID:0000000011539049

COMPONENT PART

Check the mounting conditions (looseness, backlash) of each component. Verify the component conditions (wear, damage) are normal.

Ball Joint Axial End Play

1. Set the front wheels in a straight-ahead position.
2. Hold the axle side of the transverse link, and check the axial end play by move the transverse link up and down.

Axial end play : Refer to [FSU-23. "Ball Joint"](#).

CAUTION:

- Do not depress the brake pedal when measuring.
- Do not perform this inspection with the tires on the ground.
- Be careful not to damage ball joint boot. Do not damage the components by applying excessive force.

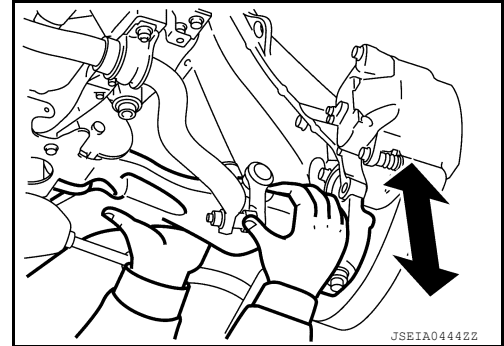

STRUT ASSEMBLY

Check for oil leaks or damage. Replace the parts if necessary.

WHEEL ALIGNMENT

< PERIODIC MAINTENANCE >

WHEEL ALIGNMENT

Inspection

INFOID:000000011539050

PRELIMINARY INSPECTION

WARNING:

Always adjust the wheel alignment with the vehicle on a flat surface.

NOTE:

If the wheel alignment is out of specification, inspect and replace any damaged or worn rear suspension parts before making any adjustments.

1. Check and adjust the wheel alignment with the vehicle under unladen conditions. "Unladen conditions" means that the fuel, engine coolant, and lubricants are full; the spare tire, jack, hand tools and mats are in designated positions.
2. Check the tires for incorrect air pressure and excessive wear.
3. Check the wheels for run out and damage. Refer to [WT-46, "Inspection"](#).
4. Check the wheel bearing axial end play. Refer to [FAX-6, "Inspection"](#).
5. Check the shock absorbers for leaks or damage.
6. Check each mounting point of the suspension components for any excessive looseness or damage.
7. Check each link, arm, and the suspension member for any damage.
8. Check the vehicle height. Refer to [FSU-23, "Wheelarch Height \(Unladen*\)"](#).

GENERAL INFORMATION AND RECOMMENDATIONS

1. A Four-Wheel Thrust Alignment should be performed.
 - This type of alignment is recommended for any NISSAN vehicle.
 - The four-wheel "thrust" process helps ensure that the vehicle is properly aligned and the steering wheel is centered.
 - The alignment machine itself should be capable of accepting any NISSAN vehicle.
 - The alignment machine should be checked to ensure that it is level.
2. Make sure the alignment machine is properly calibrated.
 - Your alignment machine should be regularly calibrated in order to give correct information.
 - Check with the manufacturer of your specific alignment machine for their recommended Service/Calibration Schedule.

THE ALIGNMENT PROCESS

IMPORTANT: Use only the alignment specifications listed in this Service Manual. Refer to [FSU-23, "Wheel Alignment \(Unladen*1\)"](#).

- When displaying the alignment settings, many alignment machines use "indicators": (Green/red, plus or minus, Go/No Go). **Do NOT use these indicators.**
- The alignment specifications programmed into your alignment machine that operate these indicators may not be correct.
- This may result in an ERROR.
- Most camera-type alignment machines are equipped with both "Rolling Compensation" method and optional "Jacking Compensation" method to "compensate" the alignment targets or head units. "Rolling Compensation" is the preferred method.
- If using the "Rolling Compensation" method, after installing the alignment targets or head units, push or pull on the rear wheel to move the vehicle. Do not push or pull the vehicle body.
- If using the "Jacking Compensation" method, after installing the alignment targets or head units, raise the vehicle and rotate the wheels 1/2 turn both ways.

NOTE:

Do not use the "rolling Compensation" method if you are using sensor-type alignment equipment.

- Follow all instructions for the alignment machine you're using for more information.

CAMBER, CASTER AND KINGPIN INCLINATION ANGLES INSPECTION

- Camber, caster, kingpin inclination angles cannot be adjusted.
- Before inspection, set the front wheels onto a turning radius gauge. Set the rear wheels onto a pad that has the same height so the vehicle will remain horizontal.

TOTAL TOE-IN INSPECTION

Measure the total toe-in using the following procedure.

WHEEL ALIGNMENT

< PERIODIC MAINTENANCE >

WARNING:

- Always perform the following procedure on a flat surface.
 - Make sure that no person is in front of vehicle before pushing it.
1. Bounce the front of vehicle up and down to stabilize the vehicle height (posture).
 2. Push on the rear wheel to move the vehicle straight ahead about 5 m (16 ft).
 3. Put a mark on base line of the tread (rear side) of both tires at the same height of hub center. These are measuring points.

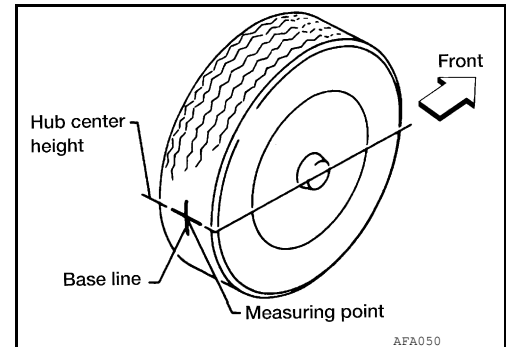

4. Measure the distance (A) from the rear side.
5. Push on the rear wheel to move the vehicle slowly ahead and to rotate the wheels 180 degrees (1/2 turn).

CAUTION:

If the wheels have rotated more than 180 degrees (1/2 turn), try the above procedure again from the beginning. Do not push vehicle backward.

6. Measure the distance (B) from the front side.

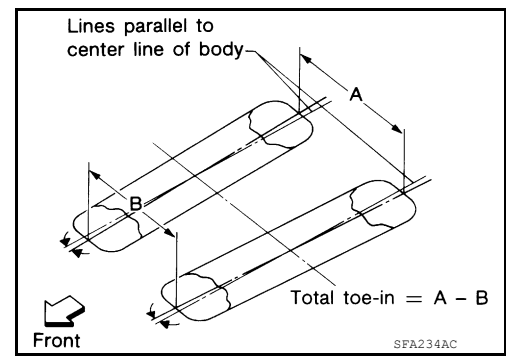

7. Use the formula below to calculate total toe-in.

Total toe-in : A - B

Total toe-in specification : Refer to [FSU-23, "Wheel Alignment \(Unladen*1\)"](#).

- If the total toe-in is outside the specification, adjust the total toe-in. Refer to [FSU-7, "Adjustment"](#).

Adjustment

INFOID:000000011539051

TOTAL TOE-IN

Loosen the steering outer socket. Adjust the length using the steering inner socket.

Toe-in : Refer to [FSU-23, "Wheel Alignment \(Unladen*1\)"](#).

CAUTION:

- Always evenly adjust both toe-in alternately and adjust the difference between the left and right to the standard.
- Always hold the steering inner socket when tightening the steering outer socket.

FRONT COIL SPRING AND STRUT

< REMOVAL AND INSTALLATION >

REMOVAL AND INSTALLATION

FRONT COIL SPRING AND STRUT

Exploded View

INFOID:000000011539052

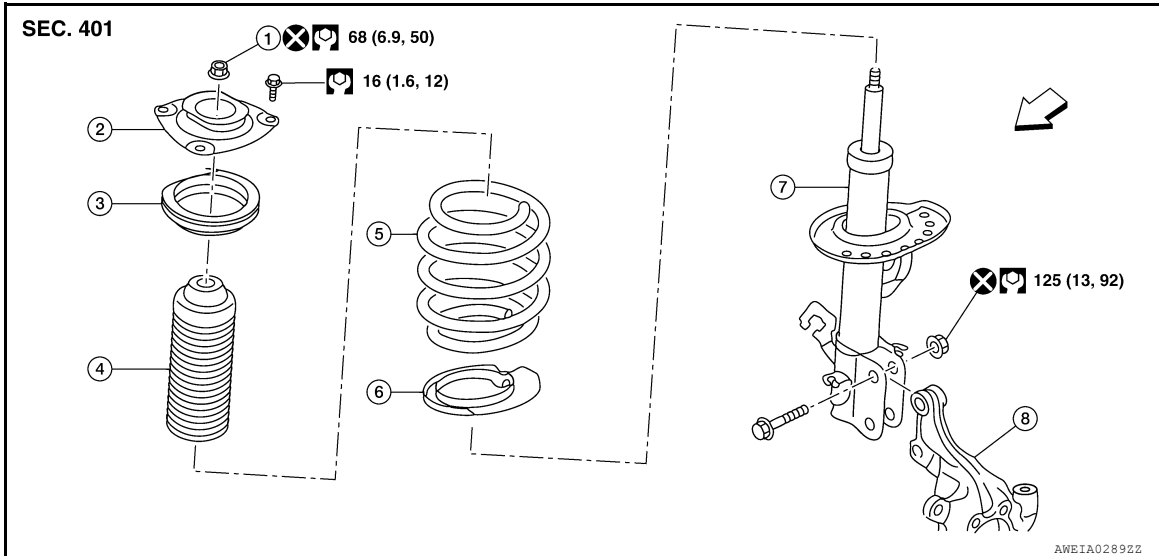

- | | | |
|------------------------|--------------------------|------------------------|
| 1. Piston rod lock nut | 2. Strut mount insulator | 3. Strut mount bearing |
| 4. Bound bumper | 5. Coil spring | 6. Lower rubber seat |
| 7. Strut | 8. Steering knuckle | ⇐ Front |

Removal and Installation

INFOID:000000011539053

REMOVAL

1. Remove the wheel and tire using power tool. Refer to [WT-47. "Exploded View"](#).
2. Remove the lock plate from the front coil spring and strut and reposition the brake hose. Refer to [BR-23. "FRONT : Exploded View"](#).
3. Disconnect the stabilizer connecting rod from the front coil spring and strut. Refer to [FSU-12. "Removal and Installation"](#).
4. Remove the wheel sensor bolt. Position the wheel sensor and the wheel sensor harness aside. Refer to [BRC-113. "FRONT WHEEL SENSOR : Removal and Installation"](#).
5. Use a jack to support the transverse link and the steering knuckle.
6. Remove the lower strut nuts and bolts (⇐).

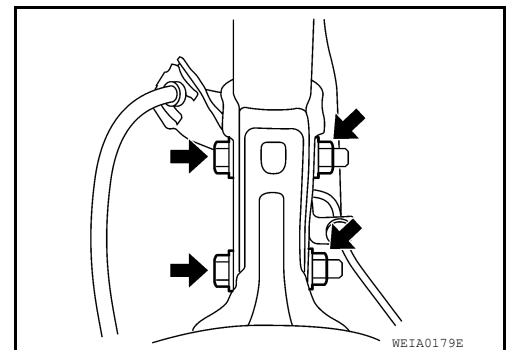

FRONT COIL SPRING AND STRUT

< REMOVAL AND INSTALLATION >

7. Remove the grommet (A) from the cowl top cover.

⇐ : Front

8. Access 1 upper strut bolt through the grommet hole.
9. Remove the upper strut bolts from the strut mount insulator (1).
10. Remove the front coil spring and strut.
11. Inspect the components. Refer to [FSU-21, "Inspection"](#).

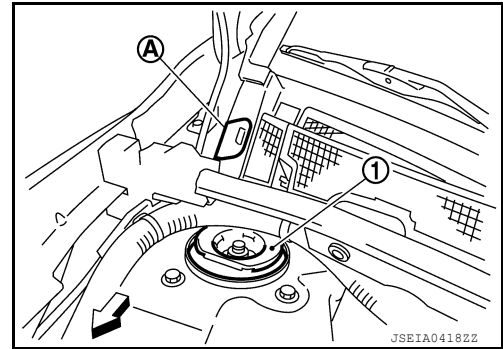

INSTALLATION

Installation is in the reverse order of removal.

CAUTION:

- Do not reuse piston rod lock nut.
- Do not reuse the lower strut nuts.
- Install the front coil spring and strut with the identification mark (A) of the strut mount insulator facing toward the front of the vehicle and the arrow (B) facing the outboard side.

NOTE:

- The identification mark "0" shows the (RH) strut mount insulator and "1" shows the (LH).
- Perform the final tightening of the bolts and nuts under unladen conditions with the tires on level ground.
- Complete the inspection. Refer to [FSU-21, "Inspection"](#).
- After replacing the strut, always follow the disposal procedure to discard the old strut. Refer to [FSU-22, "Disposal"](#).

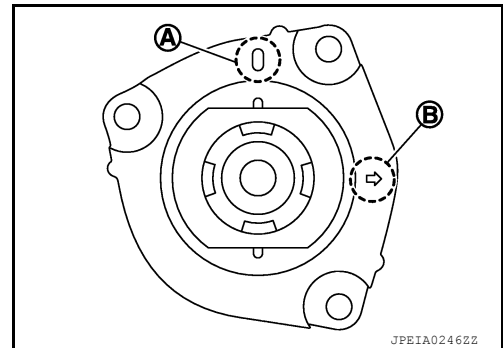

A
B
C
D
F
G
H
I
J
K
L
M
N
O
P

FSU

TRANSVERSE LINK

< REMOVAL AND INSTALLATION >

TRANSVERSE LINK

Exploded View

INFOID:000000011539054

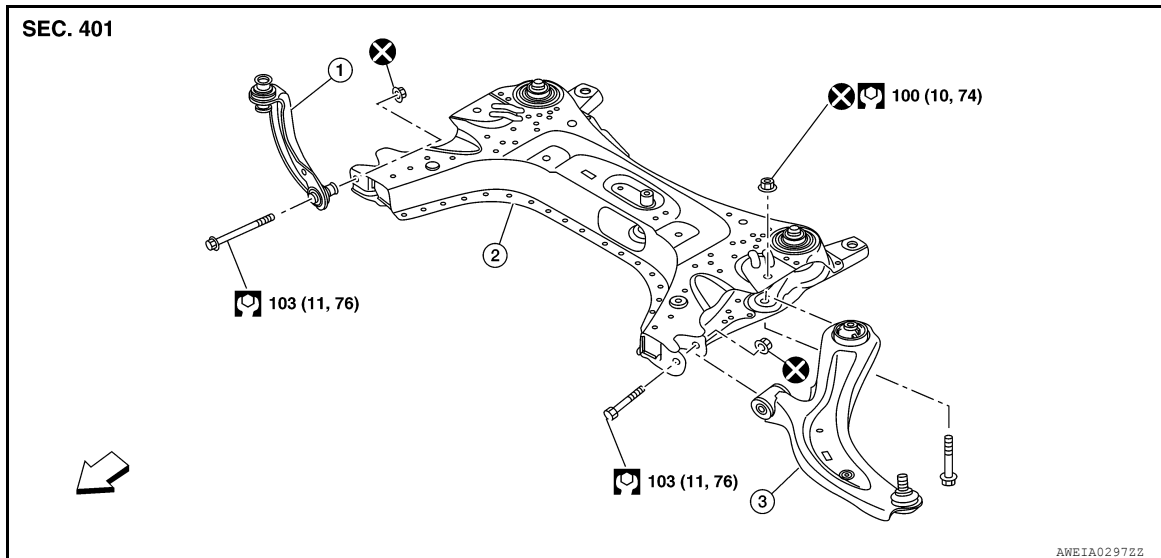

1. Upper link
2. Front suspension member
3. Transverse link
- ⇐ Front

Removal and Installation

INFOID:000000011539055

REMOVAL

1. Remove the wheel and tire using power tool. Refer to [WT-47, "Exploded View"](#).
2. Remove the nut and bolt from the lower ball joint. Disconnect the transverse link from steering knuckle. Refer to [FAX-8, "Exploded View"](#).
3. Remove the nuts and bolts and disconnect the transverse link from the suspension member.
4. Inspect the components. Refer to [FSU-10, "Inspection"](#).

INSTALLATION

Installation is in the reverse order of removal.

CAUTION:

Do not reuse the transverse link nuts.

- Perform the final tightening of the nuts and bolts under unladen conditions with the tires on level ground.
- Complete the inspection. Refer to [FSU-10, "Inspection"](#).

Inspection

INFOID:000000011539056

INSPECTION AFTER REMOVAL

Check the following items, and replace the parts if necessary.

Transverse Link

- Check the transverse link and bushing for deformation, cracks or damage.
- Check the ball joint boot for cracks or other damage, and also for grease leaks.

Swing Torque

1. Move the ball joint at least ten times by hand to check for smooth movement with no binding.

TRANSVERSE LINK

< REMOVAL AND INSTALLATION >

- Hook the Tool (A) on the on ball joint (B). Confirm the measurement value is within specifications when the ball joint begins moving.

Tool number : — (J-44372)
Swing torque : Refer to [FSU-23, "Ball Joint"](#).
Measurement on spring balance : Refer to [FSU-23, "Ball Joint"](#).

- If swing torque exceeds standard range, replace the transverse link.

Axial End Play

- Move the ball joint at least ten times by hand to check for smooth movement.
- Move the tip of the ball joint in the axial direction to check for looseness.

Axial end play : Refer to [FSU-23, "Ball Joint"](#).

- If the axial end play exceeds the standard value, replace the transverse link.

INSPECTION AFTER INSTALLATION

- Check the neutral position of the steering angle sensor. Refer to [BRC-55, "Work Procedure"](#).
- Check the wheel alignment. Refer to [FSU-6, "Inspection"](#).

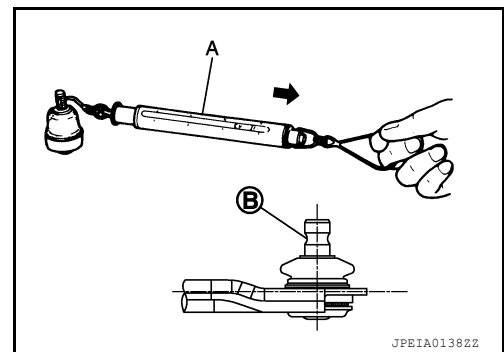

A
B
C
D

FSU

F

G

H

I

J

K

L

M

N

O

P

FRONT STABILIZER

< REMOVAL AND INSTALLATION >

FRONT STABILIZER

Exploded View

INFOID:000000011539057

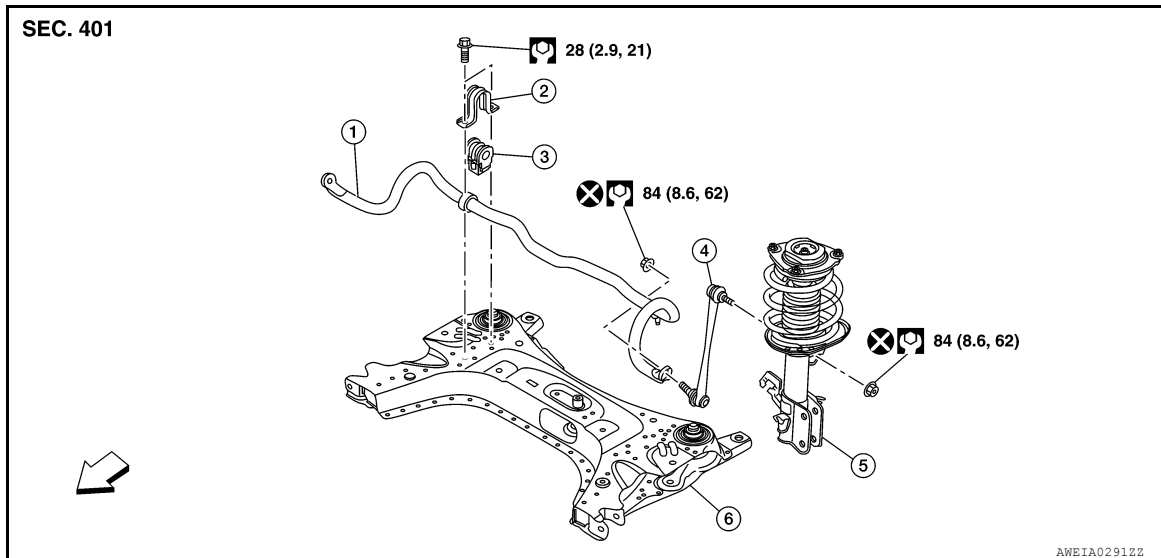

- | | | |
|------------------------------|--------------------------------|----------------------------|
| 1. Stabilizer bar | 2. Stabilizer clamp | 3. Stabilizer bushing |
| 4. Stabilizer connecting rod | 5. Front coil spring and strut | 6. Front suspension member |
- ⇐ Front

Removal and Installation

INFOID:000000011539058

REMOVAL

1. Remove the wheel and tire using power tool. Refer to [WT-47, "Exploded View"](#).
2. Remove the nut and disconnect the stabilizer connecting rod from the stabilizer bar.
3. Remove the front suspension member. Refer to [FSU-16, "Removal and Installation"](#).
4. Remove the stabilizer clamp bolts (⇐).
5. Remove the stabilizer clamps.
6. Remove the stabilizer bushings.
7. Remove the stabilizer bar.
8. Inspect the components. Refer to [FSU-13, "Inspection"](#).

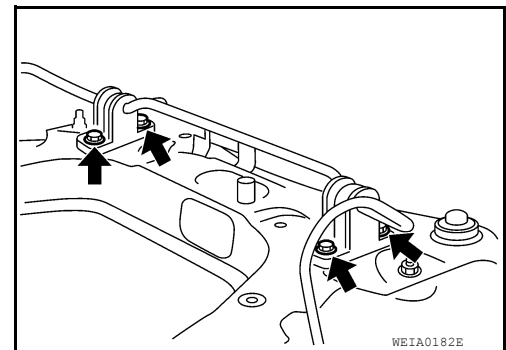

INSTALLATION

Installation is in the reverse order of removal.

FRONT STABILIZER

< REMOVAL AND INSTALLATION >

- Install the stabilizer bushing with the slit (B) facing toward the front of the vehicle (↔).
- Install the stabilizer clamp with oblong hole (A) facing toward the front of the vehicle (↔).

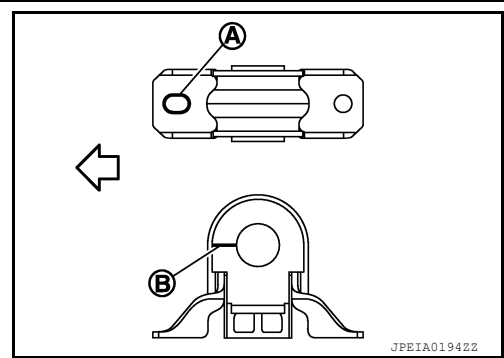

- Install the stabilizer clamp bolts in the order of 1 to 5 as shown.

Manual tightening : 1
Temporary tightening : 2 → 3
Final tightening (Specified torque) : 4 → 5

↔ : Front

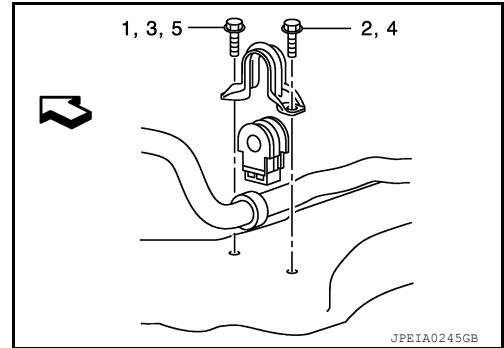

- To connect the stabilizer connecting rod (1), tighten the nut while holding the hexagonal part (A) on the stabilizer connecting rod.

CAUTION:

Do not reuse stabilizer connecting rod nuts.

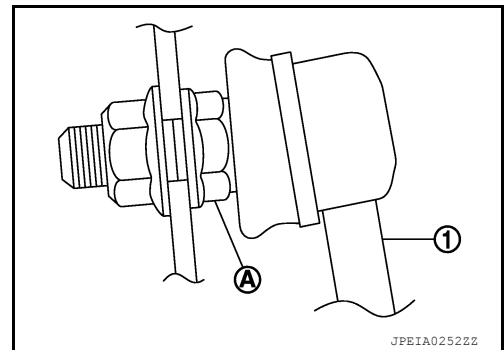

- Perform the final tightening of the nuts and bolts under unladen conditions with the tires on level ground.
- Complete the inspection. Refer to [FSU-13, "Inspection"](#).

Inspection

INFOID:000000011539059

INSPECTION AFTER REMOVAL

Check the stabilizer bar, the stabilizer connecting rods, the stabilizer bushings, and the stabilizer clamps for deformation, cracks or damage. Replace components if necessary.

INSPECTION AFTER INSTALLATION

1. Check the neutral position of the steering angle sensor. Refer to [BRC-55, "Work Procedure"](#).
2. Check the wheel alignment. Refer to [FSU-6, "Inspection"](#).

STEERING KNUCKLE

< REMOVAL AND INSTALLATION >

STEERING KNUCKLE

Exploded View

INFOID:000000011539060

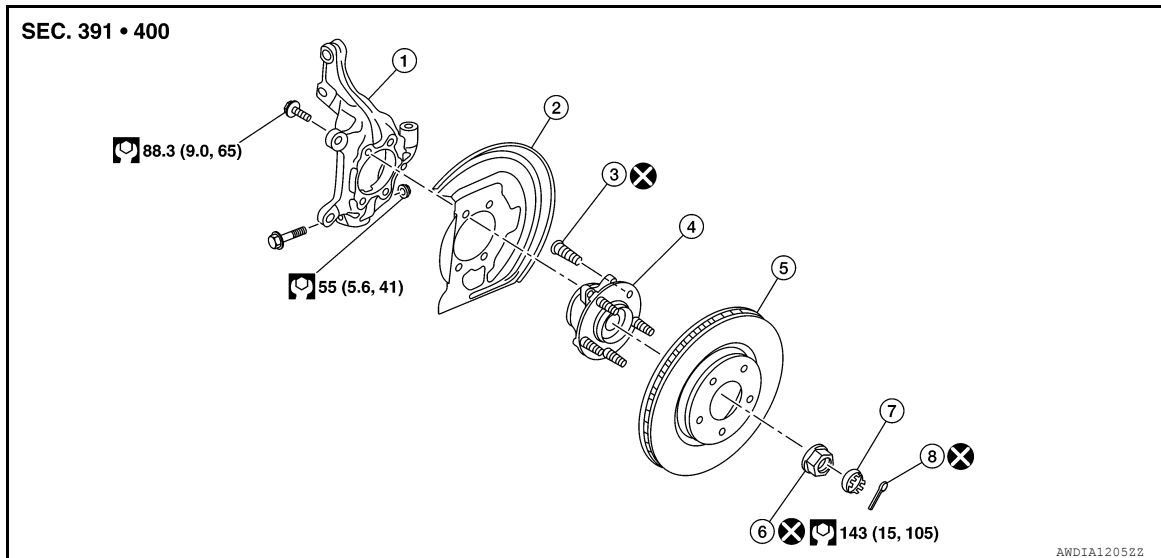

- | | | |
|--------------------------|---------------------|-----------------------|
| 1. Steering knuckle | 2. Splash guard | 3. Wheel stud |
| 4. Wheel hub and bearing | 5. Disc brake rotor | 6. Wheel hub lock nut |
| 7. Nut retainer | 8. Cotter pin | |

Removal and Installation

INFOID:000000011539061

REMOVAL

1. Remove the wheel and tire using power tool. Refer to [WT-47, "Exploded View"](#).
2. Remove the nut and disconnect the steering outer socket from the steering knuckle. Refer to [ST-14, "Removal and Installation"](#).
3. Remove the nut and bolt from the lower ball joint. Disconnect the steering knuckle from the transverse link.
4. Remove the wheel hub and bearing from the steering knuckle. Refer to [FAX-8, "Removal and Installation"](#).
5. Remove the splash guard from the steering knuckle.
6. Suspend the drive shaft with suitable wire.
7. Remove the lower strut nuts and bolts (←). Refer to [FSU-8, "Exploded View"](#).

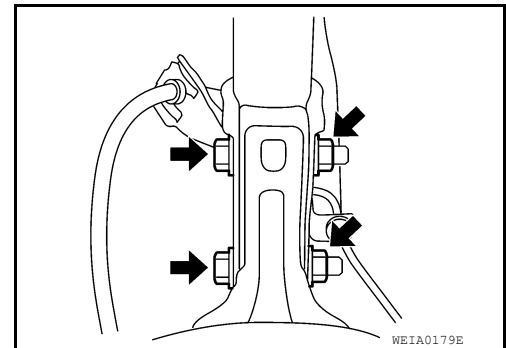

8. Remove the steering knuckle.
9. Inspect the components. Refer to [FSU-15, "Inspection"](#).

INSTALLATION

Installation is in the reverse order of the removal.

CAUTION:

- Do not reuse cotter pin.

STEERING KNUCKLE

< REMOVAL AND INSTALLATION >

- **Do not reuse the lower strut nuts.**
- Complete the inspection. Refer to [FSU-15, "Inspection"](#).

A

Inspection

INFOID:000000011539062

INSPECTION AFTER REMOVAL

B

Check the following items, and replace the part if necessary.

- Check components for deformation, cracks, and other damage.
- Check boots of transverse link and steering outer socket ball joint for breakage, axial end play, and swing torque.
- Transverse link: Refer to [FSU-10, "Inspection"](#).
- Steering outer socket: Refer to [ST-8, "Inspection"](#).

C

D

INSPECTION AFTER INSTALLATION

1. Check the wheel sensor harness to be sure the connectors are fully seated.
2. Check the wheel alignment. Refer to [FSU-6, "Inspection"](#).

FSU

F

G

H

I

J

K

L

M

N

O

P

FRONT SUSPENSION MEMBER

< UNIT REMOVAL AND INSTALLATION >

UNIT REMOVAL AND INSTALLATION

FRONT SUSPENSION MEMBER

Exploded View

INFOID:000000011539063

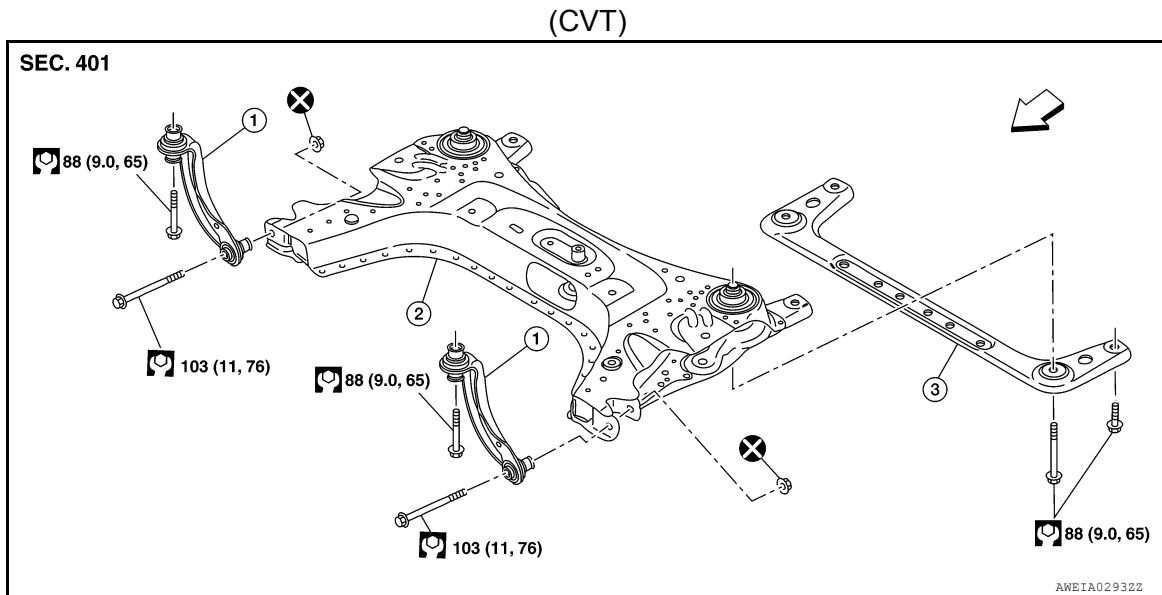

1. Upper link

2. Front suspension member

3. Member stay

⇐ Front

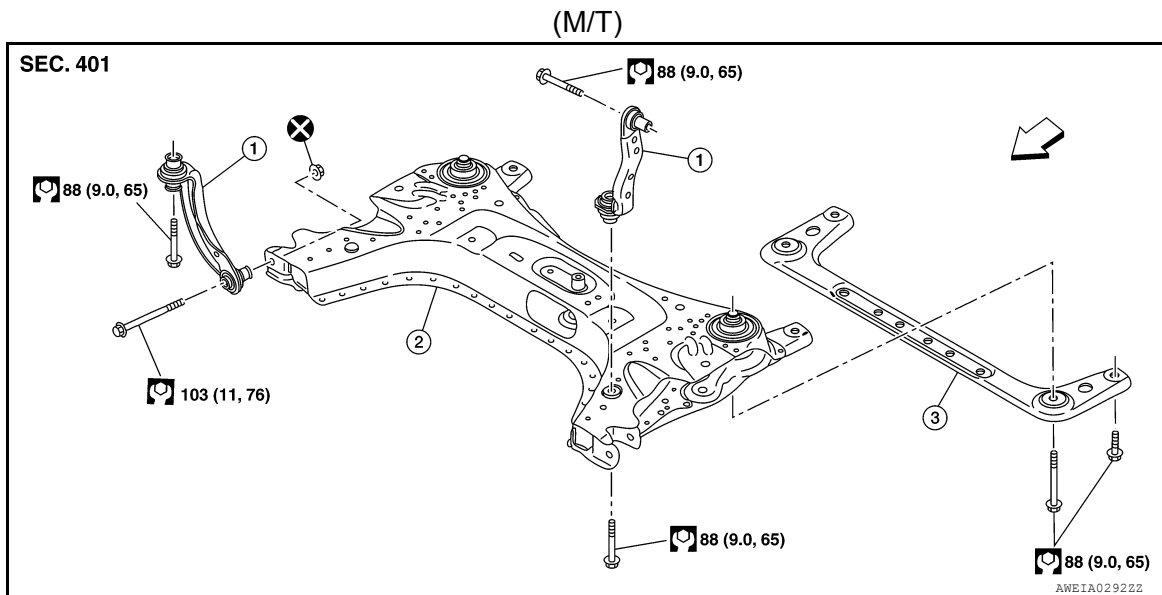

1. Upper link

2. Front suspension member

3. Member stay

⇐ Front

Removal and Installation

INFOID:000000011539064

REMOVAL

1. Remove the front wheel and tire using power tool. Refer to [WT-47, "Exploded View"](#).
2. Remove the front under cover and the engine under cover. Refer to [EXT-31, "FRONT UNDER COVER : Removal and Installation"](#).
3. Disconnect the steering gear from the lower shaft. Refer to [ST-12, "Removal and Installation"](#).

FRONT SUSPENSION MEMBER

< UNIT REMOVAL AND INSTALLATION >

4. Disconnect the steering outer socket from the steering knuckle. Refer to [ST-14, "Removal and Installation"](#).
5. Remove the nut and bolt from the lower ball joint. Disconnect the transverse link from the steering knuckle. Refer to [FAX-8, "Exploded View"](#).
6. Remove the rear torque rod and the rear torque rod bracket.
 - MRA8DE (M/T): Refer to [EM-82, "M/T : Removal and Installation"](#).
 - MRA8DE (CVT): Refer to [EM-86, "CVT : Removal and Installation"](#).
7. Disconnect the oxygen sensor. Refer to [EX-5, "Removal and Installation"](#).
8. Disconnect the stabilizer connecting rod from the stabilizer bar. Refer to [FSU-12, "Exploded View"](#).
9. Set a suitable jack under front suspension member.

CAUTION:

- **At this step, the suitable jack must be set only for supporting the removal procedure. For details on jacking up the vehicle, refer to [GI-32, "Garage Jack and Safety Stand and 2-Pole Lift"](#).**
- **Do not damage the front suspension member with the suitable jack.**

10. Remove the lower bolts from the upper links.
11. Remove the bolts and the member stay.
12. Remove the front suspension member bolts.
13. Gradually lower the suitable jack to remove the front suspension member from the vehicle.

CAUTION:

Make sure the front suspension member is stable when using the suitable jack.

14. If replacing the front suspension member, perform the following procedures:
 - Remove the steering gear. Refer to [ST-14, "Exploded View"](#).
 - Remove the transverse links. Refer to [FSU-10, "Exploded View"](#).
 - Remove the stabilizer bar, the stabilizer clamps, and the stabilizer bushings. Refer to [FSU-12, "Exploded View"](#).
 - Remove the oxygen sensor bracket. Refer to [EX-5, "Exploded View"](#).
15. Inspect the components. Refer to [FSU-18, "Inspection"](#).

INSTALLATION

Installation is in the reverse order of removal.

CAUTION:

Do not reuse the transverse link nuts.

- Install the member stay bolts, the upper link bolts, and the front suspension member bolts in the order of 1 to 10 as shown (if equipped with the 6M/T).

Temporary tightening : 1 → 2 → 3 → 4
 Final tightening (Specified torque) : 5 → 6 → 7 → 8 → 9 → 10

← : Front

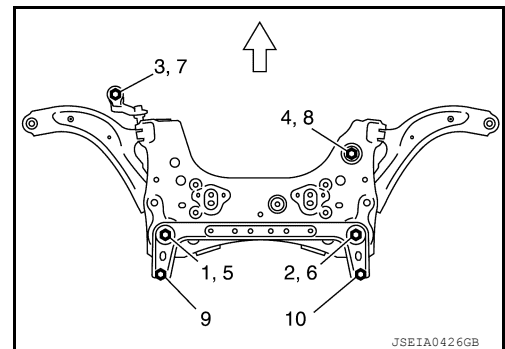

- Install the member stay bolts, the upper link bolts, and the front suspension member bolts in the order of 1 to 10 as shown (if equipped with the CVT).

Temporary tightening : 1 → 2 → 3 → 4
 Final tightening (Specified torque) : 5 → 6 → 7 → 8 → 9 → 10

← : Front

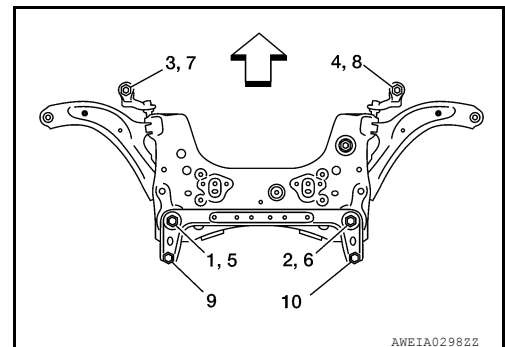

- Perform the final tightening of the nuts and bolts under unladen conditions with the tires on level ground.
- Complete the inspection. Refer to [FSU-18, "Inspection"](#).

FRONT SUSPENSION MEMBER

< UNIT REMOVAL AND INSTALLATION >

Inspection

INFOID:000000011539065

INSPECTION AFTER REMOVAL

Check the front suspension member for cracks, wear or damage. Replace components if necessary.

INSPECTION AFTER INSTALLATION

1. Check the wheel sensor harness to be sure the connectors are fully seated.
2. Check the neutral position of the steering angle sensor. Refer to [BRC-55. "Work Procedure"](#).
3. Check the wheel alignment. Refer to [FSU-6. "Inspection"](#).

FRONT COIL SPRING AND STRUT

< UNIT DISASSEMBLY AND ASSEMBLY >

UNIT DISASSEMBLY AND ASSEMBLY

FRONT COIL SPRING AND STRUT

Exploded View

INFOID:000000011539066

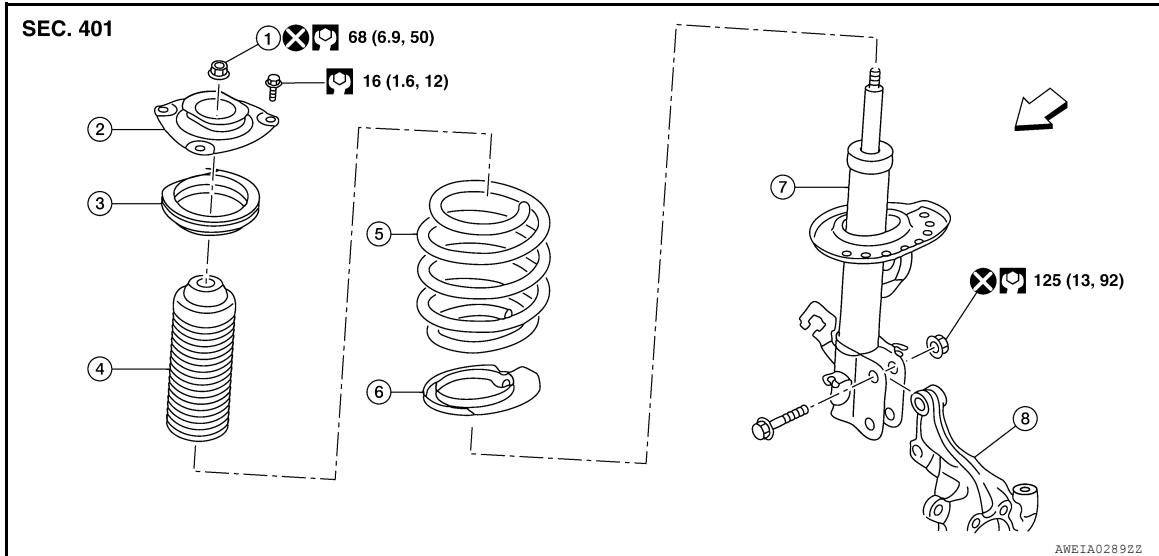

- | | | |
|------------------------|--------------------------|------------------------|
| 1. Piston rod lock nut | 2. Strut mount insulator | 3. Strut mount bearing |
| 4. Bound bumper | 5. Coil spring | 6. Lower rubber seat |
| 7. Strut | 8. Steering knuckle | ⇐ Front |

Disassembly and Assembly

INFOID:000000011539067

DISASSEMBLY

CAUTION:

Do not damage the piston rod when removing components from the front coil spring and strut.

1. Install Tool (A) to the front coil spring and strut.

CAUTION:

When installing Tool (A), wrap a shop cloth around the front coil spring and strut to protect the parts from damage.

Tool number (A) : ST35652000 (—)

2. Secure Tool (A) in a vise.

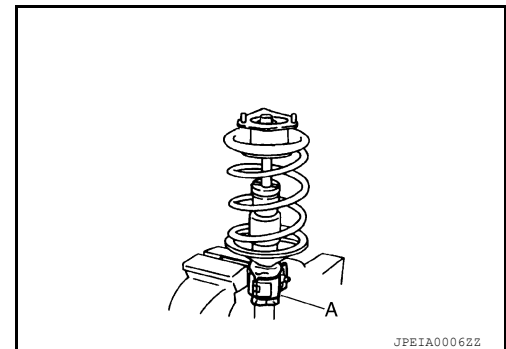

3. Slightly loosen the piston rod lock nut.

WARNING:

Do not remove the piston rod lock nut completely. If the piston rod lock nut is removed completely, the coil spring can jump out and may cause serious damage or injury.

FRONT COIL SPRING AND STRUT

< UNIT DISASSEMBLY AND ASSEMBLY >

4. Compress the coil spring using a suitable tool (A).

WARNING:

Make sure that the pawls of the suitable tool are firmly hooked on the coil spring. The suitable tool must be tightened alternately so as to not tilt the coil spring.

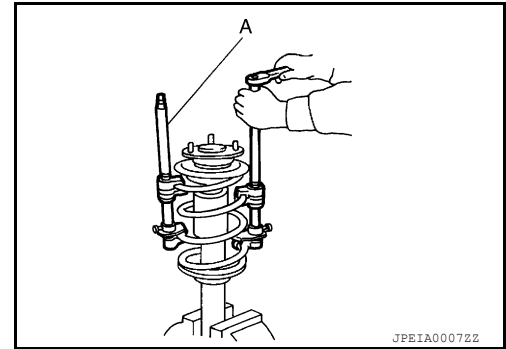

5. Make sure the coil spring is free between the strut mount insulator and the lower rubber seat.
6. Hold the piston rod and remove the piston rod lock nut.
7. Remove the strut mount insulator, the strut mount bearing, and the bound bumper from the strut.
8. Gradually release the suitable tool and remove the coil spring.

CAUTION:

Release the suitable tool while making sure the position of the suitable tool on the coil spring does not move.

9. Remove the lower rubber seat.
10. Inspect the components. Refer to [FSU-21, "Inspection"](#).

ASSEMBLY

CAUTION:

Do not damage the piston rod when removing components from the front coil spring and strut.

1. Install the lower rubber seat to the strut.
2. Identify the upper side of the coil spring.

⇐ : Upper side

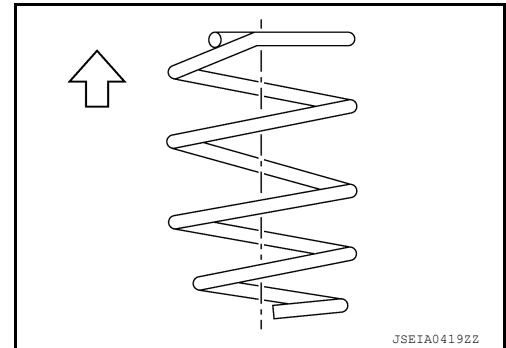

3. Compress the coil spring using a suitable tool.

WARNING:

Make sure that the pawls of the suitable tool are firmly hooked on the coil spring. The suitable tool must be tightened alternately so as to not tilt the coil spring.

4. Align the lower end of the coil spring (1) with the lower rubber seat (2) as shown.

Maximum Gap (A) : 5 mm (0.2 in)

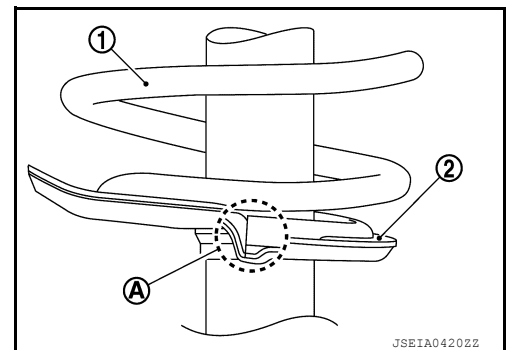

5. Apply soapy water to the bound bumper.

CAUTION:

Do not use machine oil.

6. Install the bound bumper to the strut.

FRONT COIL SPRING AND STRUT

< UNIT DISASSEMBLY AND ASSEMBLY >

7. Install the strut mount bearing to the coil spring.

CAUTION:

Do not apply oil, such as grease, when installing the strut mount bearing.

8. Install the strut mount insulator to the strut with the identification mark (A) of the strut mount insulator facing toward the front of the vehicle and the arrow (B) facing the outboard side.

NOTE:

The identification mark "0" shows the (RH) strut mount insulator and "1" shows the (LH).

9. Secure the piston rod tip so that the piston rod does not turn. Install the piston rod lock nut and tighten to the specified torque.

CAUTION:

Do not reuse piston rod lock nut.

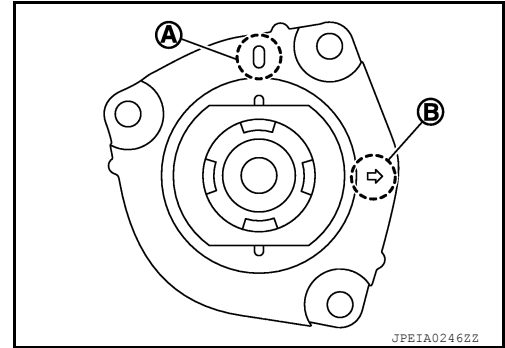

10. Gradually release the suitable tool (A) and remove the suitable tool from the coil spring.

CAUTION:

Release the suitable tool while making sure the position of the suitable tool on the coil spring does not move.

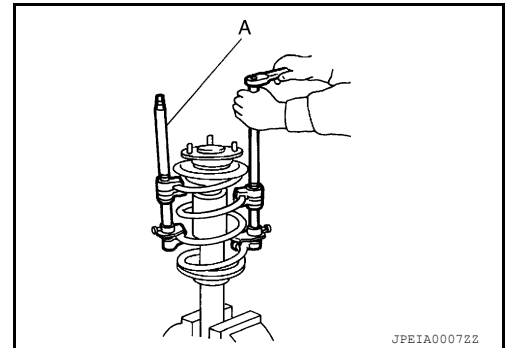

11. Remove Tool (A) from the vise.

12. Remove Tool (A) from the front coil spring and strut.

13. After replacing the strut, always follow the disposal procedure to discard the old strut. Refer to [FSU-22. "Disposal"](#).

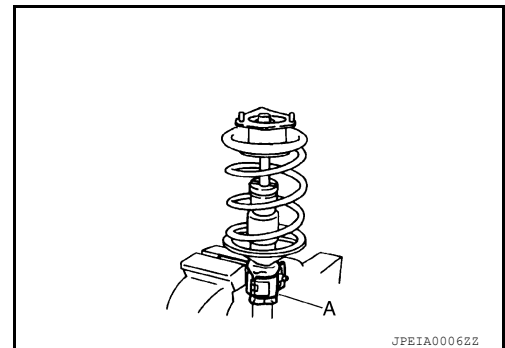

INFOID:000000011539068

Inspection

INSPECTION AFTER DISASSEMBLY

Check the following items and replace the parts if necessary.

Strut

- Check the strut for oil leaks, deformation, cracks, or damage.
- Check the piston rod for damage, uneven wear, or distortion.

Strut Mount Insulator and bound bumper

Check the strut mount insulator and the bound bumper for cracks, wear, or damage.

Coil Spring

Check the coil spring for cracks, wear, or damage.

INSPECTION AFTER INSTALLATION

1. Check the wheel sensor harness to be sure the connectors are fully seated.
2. Check the neutral position of the steering angle sensor. Refer to [BRC-55. "Work Procedure"](#).
3. Check the wheel alignment. Refer to [FSU-6. "Inspection"](#).

FRONT COIL SPRING AND STRUT

< UNIT DISASSEMBLY AND ASSEMBLY >

Disposal

INFOID:000000011539069

1. Set the strut horizontally with the piston rod fully extended.
2. Drill a 2 – 3 mm (0.08 – 0.12 in) hole at the position (●) from top as shown to release gas gradually.

CAUTION:

- Wear eye protection (safety glasses).
- Wear gloves.
- Be careful with metal chips or oil blown out by the compressed gas.

NOTE:

- Drill vertically in this direction (←) directly to the outer tube avoiding brackets.
- The gas is clear, colorless, odorless, and harmless.

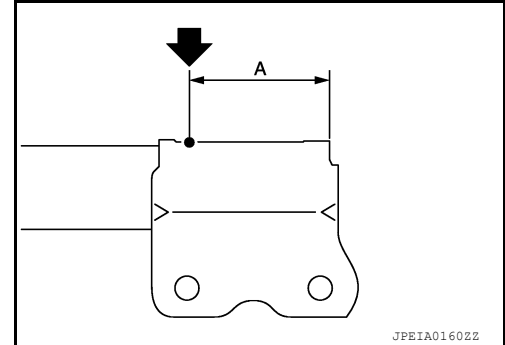

(A) : 20 – 30 mm (0.79 – 1.18 in)

3. Position the drilled hole downward and drain oil by moving the piston rod several times.

CAUTION:

Dispose of drained oil according to the law and local regulations.

SERVICE DATA AND SPECIFICATIONS (SDS)

< SERVICE DATA AND SPECIFICATIONS (SDS)

SERVICE DATA AND SPECIFICATIONS (SDS)

SERVICE DATA AND SPECIFICATIONS (SDS)

Wheel Alignment (Unladen*1)

INFOID:000000011539070

UNITED STATES and CANADA

Camber Degree minute (Decimal degree)	Minimum	-1° 04' (-1.07°)
	Nominal	-0° 25' (-0.42°)
	Maximum	0° 14' (0.23°)
	(LH) and (RH) difference*2	-0° 35' (-0.58°) - 0° 35' (0.58°)
Caster Degree minute (Decimal degree)	Minimum	4° 05' (4.08°)
	Nominal	4° 50' (4.83°)
	Maximum	5° 35' (5.58°)
	(LH) and (RH) difference*2	-0° 45' (-0.75°) - 0° 45' (0.75°)
Kingpin inclination Degree minute (Decimal degree)	Minimum	11° 20' (11.33°)
	Nominal	12° 05' (12.08°)
	Maximum	12° 50' (12.83°)

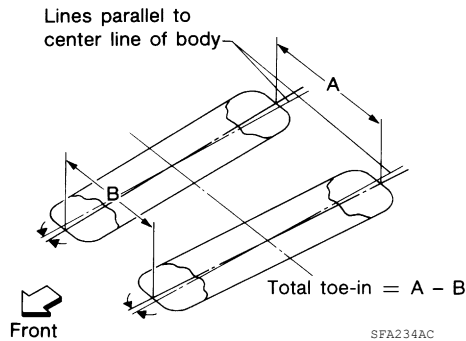

Total toe-in	Distance (A - B)	Minimum	0 mm (0.0 in)
		Nominal	In 2 mm (In 0.08 in)
		Maximum	In 4 mm (In 0.16 in)
	Angle (LH and RH) Degree minute (Decimal degree)	Minimum	0° 0' (0°)
		Nominal	In 0° 10' (In 0.17°)
		Maximum	In 0° 20' (In 0.34°)

*1: Fuel, engine coolant, and lubricants are full. Spare tire, jack, hand tools, and mats are in designated positions.

*2: The difference when assuming the (LH) side is the standard.

Ball Joint

INFOID:000000011539071

Swing torque	0.5 – 4.9 N·m (0.05 – 0.50 kg-m, 4 – 43 in-lb)
Measurement on spring balance	15.4 – 150.8 N (1.57 – 15.38 kg, 3.46 – 33.90 lb)
Axial end play	0 mm (0 in)

Wheelarch Height (Unladen*)

INFOID:000000011539072

UNITED STATES

SERVICE DATA AND SPECIFICATIONS (SDS)

< SERVICE DATA AND SPECIFICATIONS (SDS)

Unit: mm (in)

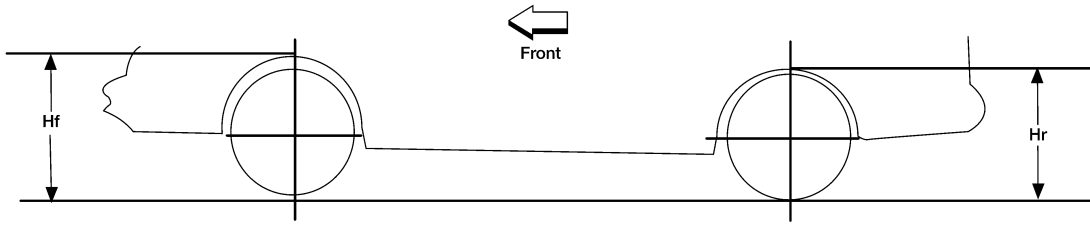

LEIA0085E

Transaxle	6M/T or CVT		CVT	
	Tire size	205/55R16 (Except FE)	205/55R16 (FE)	205/50R17
Front (Hf)	703 (27.68)	706 (27.80)	708 (27.87)	
Rear (Hr)	703 (27.68)	706 (27.80)	707 (27.83)	

*: Fuel, engine coolant, and lubricants are full. Spare tire, jack, hand tools, and mats are in designated positions.

CANADA

Unit: mm (in)

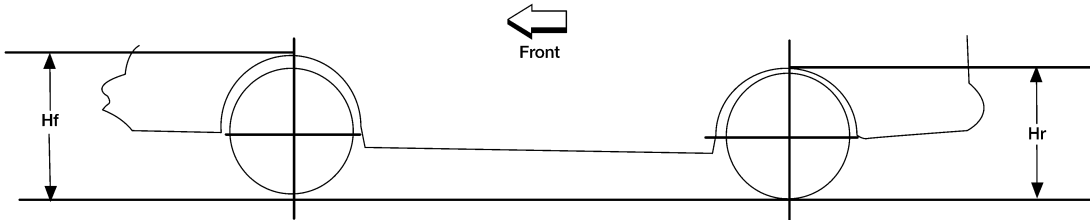

LEIA0085E

Transaxle	6M/T or CVT		CVT	
	Tire size	205/55R16		205/50R17
Front (Hf)	704 (27.72)		709 (27.91)	
Rear (Hr)	704 (27.72)		708 (27.87)	

*: Fuel, engine coolant, and lubricants are full. Spare tire, jack, hand tools, and mats are in designated positions.