

A
FL
C
D
E
F
G
H
I
J
K
L
M
N
O
P

SECTION **FL**

FUEL SYSTEM

CONTENTS

PRECAUTION	Removal and Installation	7	
	Inspection	10	
PRECAUTIONS	FUEL TANK	11	
Precaution for Supplemental Restraint System (SRS) "AIR BAG" and "SEAT BELT PRE-TENSIONER"	Exploded View	11	
General Precaution	Removal and Installation	12	
	Inspection	15	
PREPARATION	EVAP CANISTER	16	
	Exploded View	16	
PREPARATION	Removal and Installation	17	
Special Service Tool	DISASSEMBLY AND ASSEMBLY	19	
Commercial Service Tool	FUEL LEVEL SENSOR UNIT	19	
PERIODIC MAINTENANCE	Exploded View	19	
	Disassembly and Assembly	19	
FUEL SYSTEM	SERVICE DATA AND SPECIFICATIONS (SDS)	21	
Inspection	SERVICE DATA AND SPECIFICATIONS (SDS)	21	
Quick Connector	Fuel Tank	21	
REMOVAL AND INSTALLATION			
FUEL LEVEL SENSOR UNIT, FUEL FILTER AND FUEL PUMP ASSEMBLY			
Exploded View			

PRECAUTIONS

< PRECAUTION >

PRECAUTION

PRECAUTIONS

Precaution for Supplemental Restraint System (SRS) "AIR BAG" and "SEAT BELT PRE-TENSIONER"

INFOID:000000012788271

The Supplemental Restraint System such as "AIR BAG" and "SEAT BELT PRE-TENSIONER", used along with a front seat belt, helps to reduce the risk or severity of injury to the driver and front passenger for certain types of collision. Information necessary to service the system safely is included in the SR and SB section of this Service Manual.

WARNING:

- To avoid rendering the SRS inoperative, which could increase the risk of personal injury or death in the event of a collision which would result in air bag inflation, it is recommended that all maintenance and repair be performed by an authorized NISSAN/INFINITI dealer.
- Improper repair, including incorrect removal and installation of the SRS, can lead to personal injury caused by unintentional activation of the system. For removal of Spiral Cable and Air Bag Module, see the SR section.
- Do not use electrical test equipment on any circuit related to the SRS unless instructed to in this Service Manual. SRS wiring harnesses can be identified by yellow and/or orange harnesses or harness connectors.

PRECAUTIONS WHEN USING POWER TOOLS (AIR OR ELECTRIC) AND HAMMERS

WARNING:

- When working near the Air Bag Diagnosis Sensor Unit or other Air Bag System sensors with the Ignition ON or engine running, DO NOT use air or electric power tools or strike near the sensor(s) with a hammer. Heavy vibration could activate the sensor(s) and deploy the air bag(s), possibly causing serious injury.
- When using air or electric power tools or hammers, always switch the Ignition OFF, disconnect the battery or batteries, and wait at least three minutes before performing any service.

General Precaution

INFOID:000000012788272

WARNING:

When replacing fuel line parts, be sure to observe the following.

- Put a "CAUTION: FLAMMABLE" sign in the work area.
- Be sure to work in a well ventilated area and have a CO² fire extinguisher.
- Do not smoke while working on the fuel system. Keep open flames and sparks away from the work area.

CAUTION:

- Before removing fuel line parts, carry out the following procedures:
 - Put drained fuel in an explosion-proof container and put the lid on securely. Keep the container in safe area.
 - Release fuel pressure from the fuel lines. Refer to [EC-50, "EVAPORATIVE EMISSION SYSTEM : System Description"](#).
 - Disconnect the battery ground cable.
 - Always replace O-rings and clamps with new ones.
 - Do not kink or twist tubes when they are being installed.
 - Do not tighten hose clamps excessively to avoid damaging hoses.
- Tighten high-pressure rubber hose clamp so that clamp end is 3 mm (0.12 in) from hose end.
Tightening torque specifications are the same for all rubber hose clamps.
Ensure that screw does not contact adjacent parts.

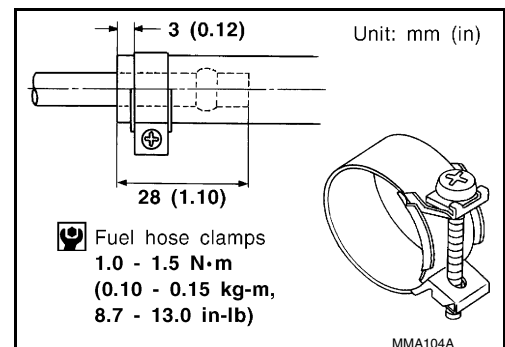

PRECAUTIONS

< PRECAUTION >

- After connecting the fuel tube quick connectors, make sure the quick connectors are secure. Check that the connector and resin tube do not contact any adjacent parts.
- a) Apply fuel pressure to the fuel system by turning the ignition switch to ON (without starting the engine). Then check for fuel leaks at the fuel tube connections.
- b) Start the engine and rev the engine, then check for fuel leaks at the fuel tube connections.
- After installing the tubes, run the engine and check for fuel leaks at the connections.
- Use only a Genuine NISSAN fuel filler cap as a replacement. If an incorrect fuel filler cap is used, the MIL may come on.
- For servicing "Evaporative Emission System" parts, refer to [EC-50, "EVAPORATIVE EMISSION SYSTEM : System Description"](#).

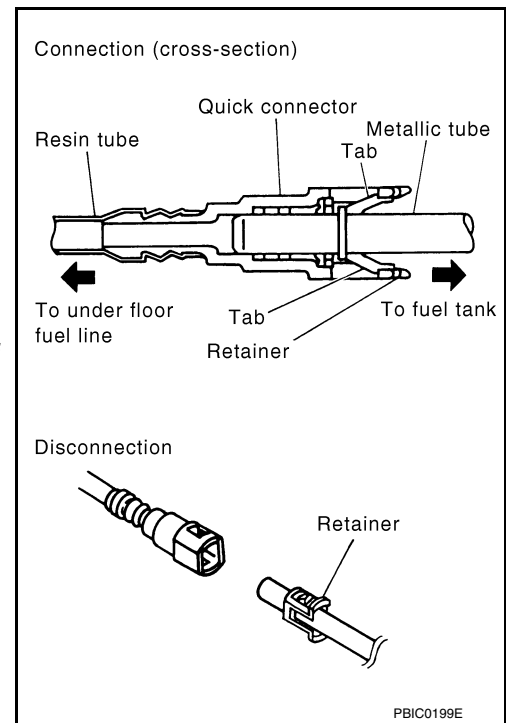

A

FL

C

D

E

F

G

H

I

J

K

L

M

N

O

P

PREPARATION

< PREPARATION >

PREPARATION

PREPARATION

Special Service Tool

INFOID:000000012788273

The actual shape of the tools may differ from those illustrated here.

Tool number (TechMate No.) Tool name	Description
KV101207S0 (—) Unified fuel lock ring wrench	Removing and installing fuel tank lock ring
KV991J0090 (J-46214) Lock ring wrench	

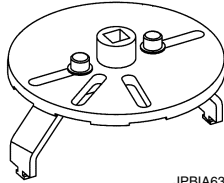

JPBIA6384ZZ

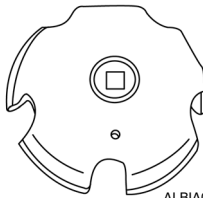

ALBIA0951ZZ

Commercial Service Tool

INFOID:000000012788274

Tool name	Description
Power tool	Loosening nuts, screws and bolts



PIIB1407E

FUEL SYSTEM

< PERIODIC MAINTENANCE >

PERIODIC MAINTENANCE

FUEL SYSTEM

Inspection

Inspect fuel lines, fuel filler cap, and fuel tank for improper attachment, leakage, cracks, damage, loose connections, chafing or deterioration.

- (A) : Engine
- (B) : Fuel line
- (C) : Fuel tank

If necessary, repair or replace damaged parts.

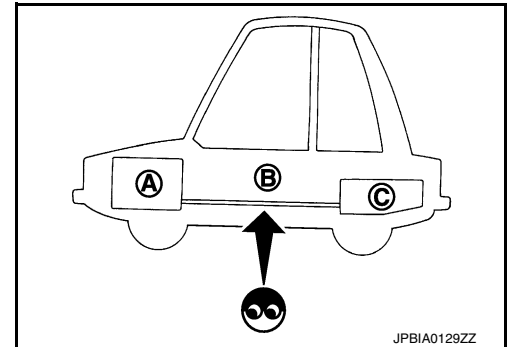

Quick Connector

CAUTION:

- After connecting fuel tube quick connectors, check quick connectors are secure.
- Ensure that connector and resin tube do not contact any adjacent parts.

A
FL
C
D
E
F
G
H
I
J
K
L
M
N
O
P

FUEL LEVEL SENSOR UNIT, FUEL FILTER AND FUEL PUMP ASSEMBLY

< REMOVAL AND INSTALLATION >

REMOVAL AND INSTALLATION

FUEL LEVEL SENSOR UNIT, FUEL FILTER AND FUEL PUMP ASSEMBLY

Exploded View

INFOID:000000012788277

FOR CALIFORNIA

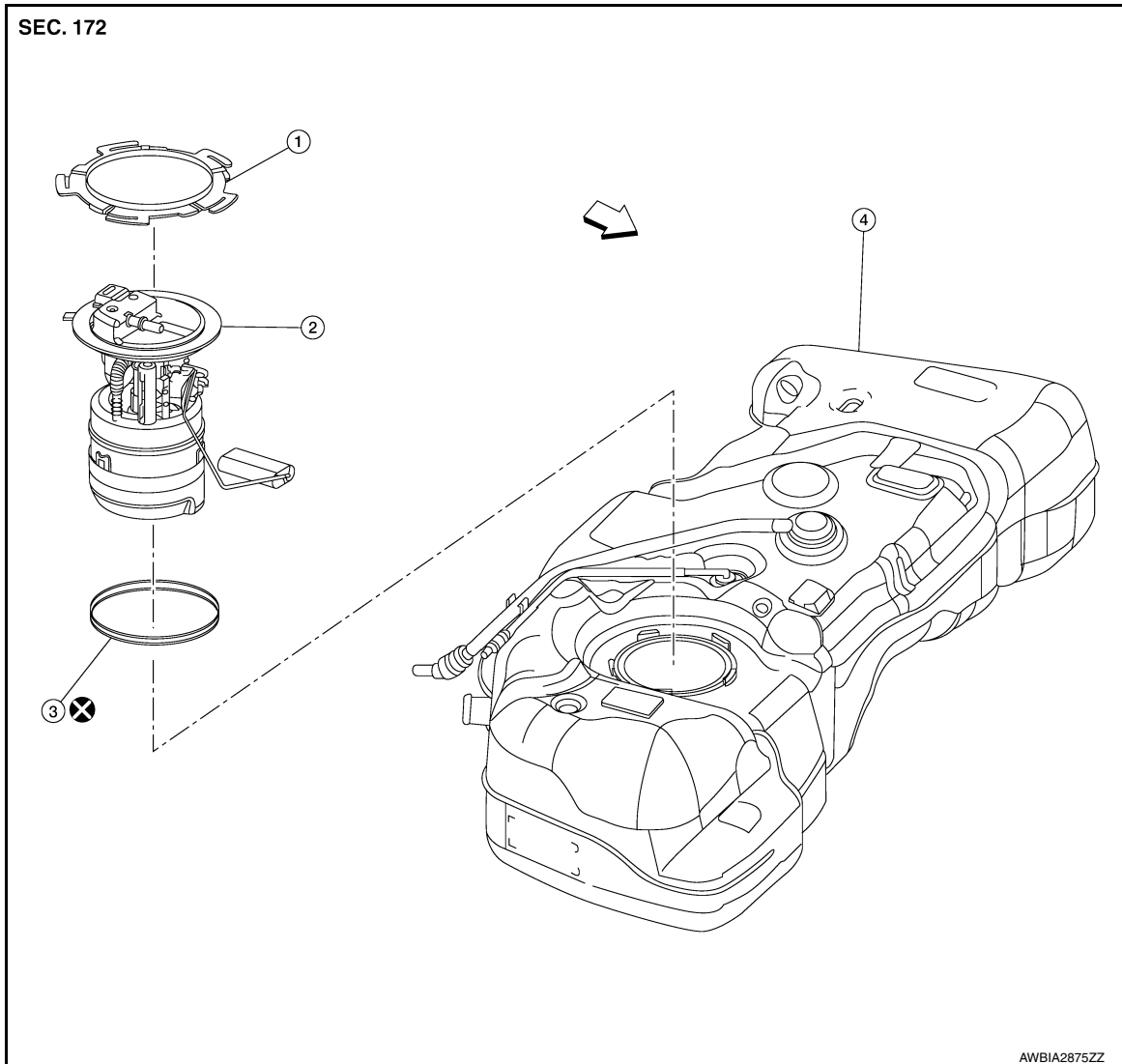

- 1. Lock ring
 - 2. Fuel level sensor, fuel filter and fuel pump assembly
 - 3. O-ring
 - 4. Fuel tank
- ↔ Front

FUEL LEVEL SENSOR UNIT, FUEL FILTER AND FUEL PUMP ASSEMBLY

< REMOVAL AND INSTALLATION >

EXCEPT FOR CALIFORNIA

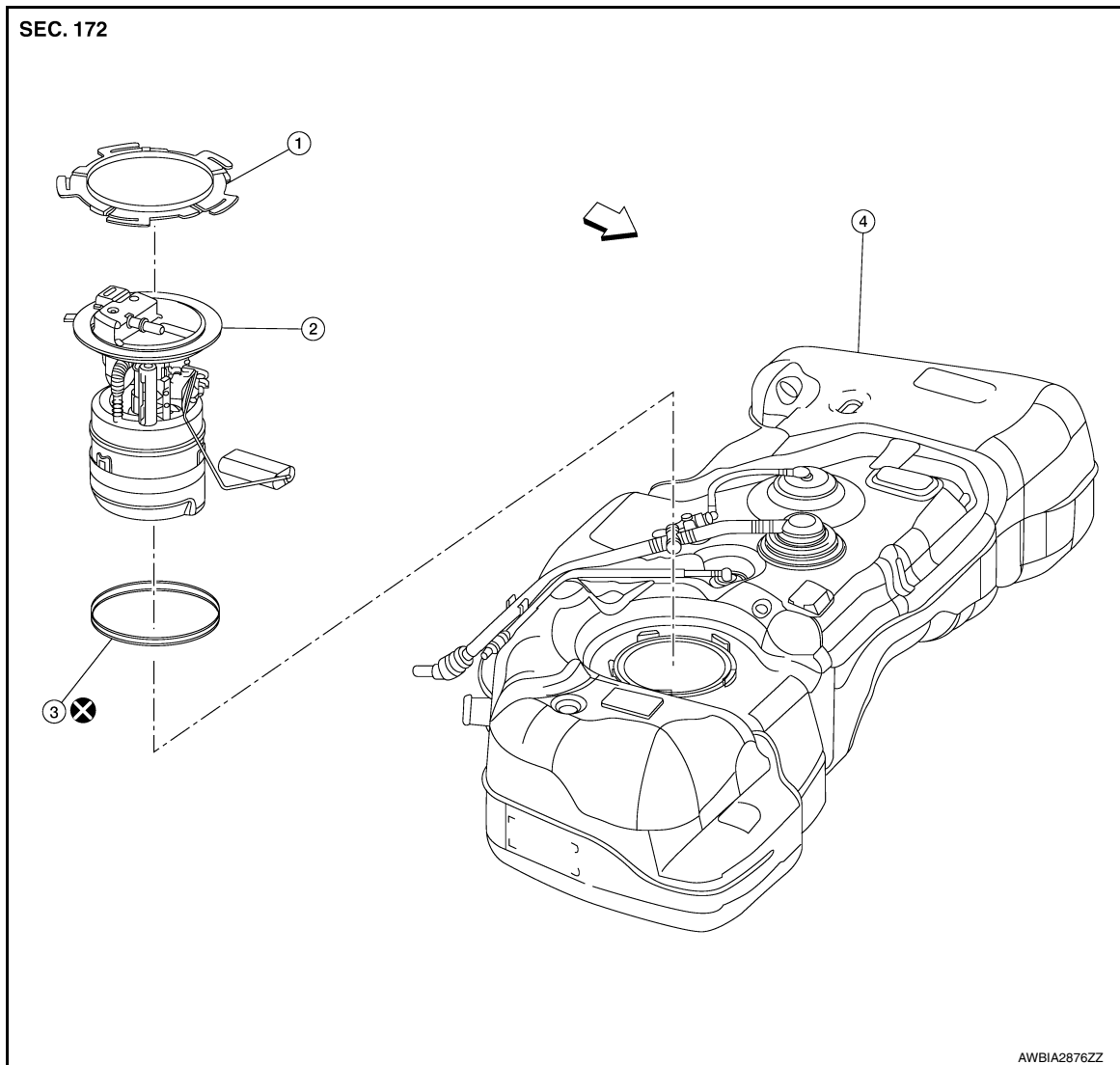

1. Lock ring
 2. Fuel level sensor, fuel filter and fuel pump assembly
 3. O-ring
 4. Fuel tank
- ↔ Front

Removal and Installation

INFOID:000000012788278

WARNING:

Read "General Precautions" when working on the fuel system. Refer to [FL-2, "General Precaution"](#).

NOTE:

When removing components such as hoses, tubes/lines, etc., cap or plug openings to prevent fluid from spilling.

REMOVAL

1. Release the fuel pressure from the fuel lines. Refer to [EC-147, "Work Procedure"](#).

FUEL LEVEL SENSOR UNIT, FUEL FILTER AND FUEL PUMP ASSEMBLY

< REMOVAL AND INSTALLATION >

2. Check the fuel level with the vehicle on a level surface. If the fuel gauge indicates more than the level as shown (1/2 full), drain the fuel from the fuel tank until the fuel gauge indicates a level at or below as shown (1/2 full).
 - In case the fuel pump does not operate, use the following procedure.
- a. Insert fuel tubing of less than 25 mm (0.98 in) diameter into the fuel filler tube through the fuel filler opening to drain fuel from the fuel filler tube.
- b. Disconnect the fuel filler hose from the fuel filler tube.
- c. Insert fuel tubing into the fuel tank through the fuel filler hose to drain fuel from the fuel tank.
 - As a guide, if the fuel tank is full the fuel level reaches or is less than the level on the fuel gauge as shown, when approximately 25 ℓ (6-5/8 US gal, 5-1/2 Imp gal) of fuel is drained from a full fuel tank.
3. Open fuel filler lid.
4. Remove trunk floor carpet. Refer to [INT-43, "TRUNK SIDE FINISHER : Removal and Installation"](#).
5. Open filler cap and release the pressure inside fuel tank.
6. Remove rear seat cushion assembly. Refer to [SE-36, "Removal and Installation - Seat Cushion Assembly"](#).
7. Remove inspection hole cover.

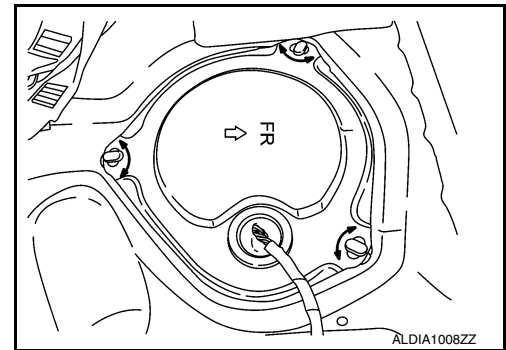
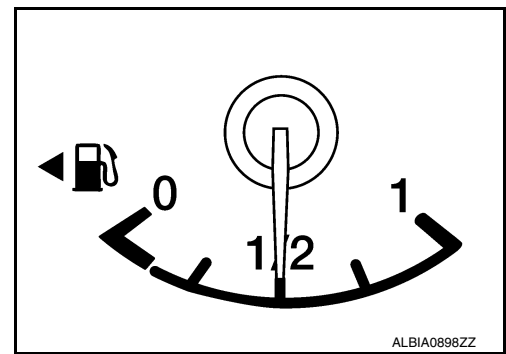

8. Disconnect harness connector (1), fuel feed hose (3) and quick connector (4) from fuel level sensor unit, fuel filter and fuel pump assembly (2).

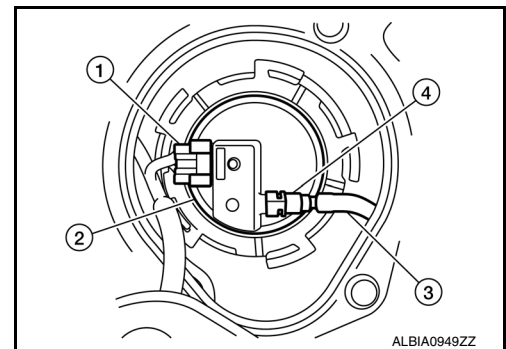

- Remove quick connector in the following procedures.
- Pinch quick connector square-part (A) with your fingers, and pull out the quick connector (1) by hand.
- If quick connector and tube on sender unit are stuck, push and pull several times until they move, and pull out.

CAUTION:

- Quick connector can be removed when the tabs are completely depressed. Do not twist it more than necessary.
- Do not use any tools to disconnected quick connector.
- Keep resin tube away from heat. Be especially careful when welding near the resin tube.
- Prevent acid liquid such as battery electrolyte, etc. from getting on resin tube.

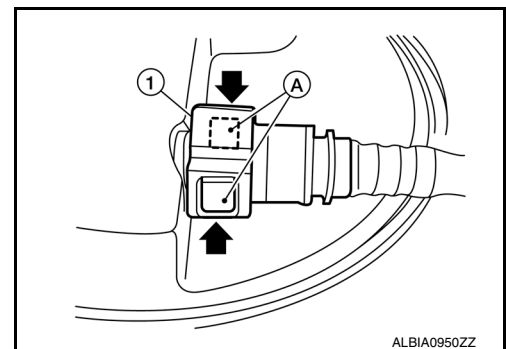

FUEL LEVEL SENSOR UNIT, FUEL FILTER AND FUEL PUMP ASSEMBLY

< REMOVAL AND INSTALLATION >

- Do not bend or twist resin tube during installation and disconnection.
- To keep the connecting portion clean and to avoid damage and foreign materials, cover them completely with plastic bags (A) or something similar.
- Do not insert plug, preventing damage on O-ring in quick connector.

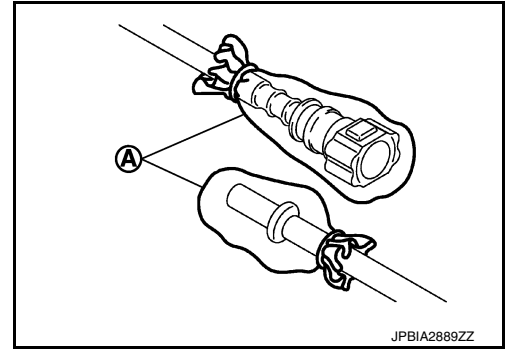

9. Remove lock ring for fuel level sensor unit, fuel filter and fuel pump assembly with Tool (A) by turning counterclockwise.

Tool number (A) : KV991J0090 (J-46214) (shown)
: KV101207S0 (—)

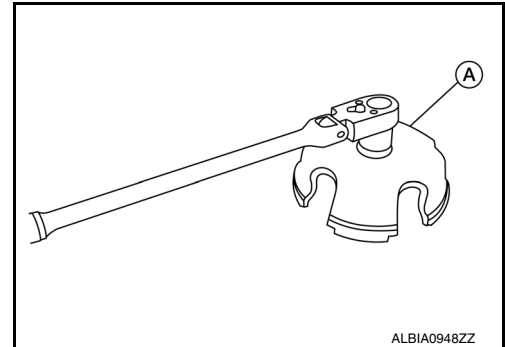

10. Remove fuel level sensor unit, fuel filter and fuel pump assembly (1).

CAUTION:

- Do not bend float arm during removal.
- Place a cloth around the fuel level sensor, fuel filter and fuel pump assembly during removal to avoid spilling fuel inside the vehicle.
- Do not cause impacts such as by dropping when handling components.

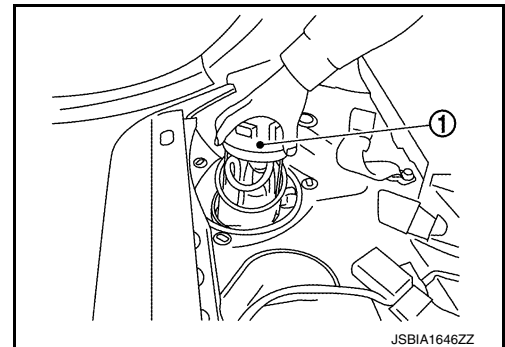

INSTALLATION

1. Install the O-ring to the opening of the fuel tank.

CAUTION:

Do not reuse O-ring.

2. Insert the fuel level sensor unit, fuel filter and fuel pump assembly to the fuel tank with its matching arrow aligned with fuel tank matching arrow.

CAUTION:

Do not bend float arm during installation.

NOTE:

For fuel level sensor assembly matching mark is located on the fuel tank to the rear side of the vehicle.

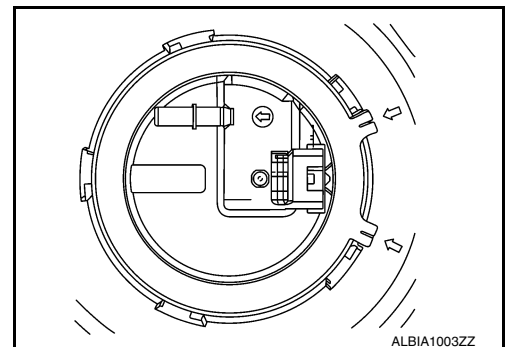

FUEL LEVEL SENSOR UNIT, FUEL FILTER AND FUEL PUMP ASSEMBLY

< REMOVAL AND INSTALLATION >

3. Install Lock ring with Tool (A) to tighten lock ring.

Tool number (A) : KV991J0090 (J-46214) (shown)
: KV101207S0 (—)

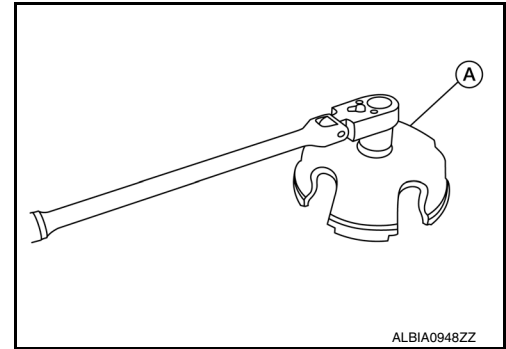

4. Installation of remaining components is in the reverse order of removal.

Quick Connector

Connect quick connector as follows:

1. Check the connection for damage or any foreign materials.
2. Align the connector with the tube, then insert the connector straight into the tube until a click sound is heard.
3. After connecting, check that the connection is secure by following method.
 - Visually confirm that the two tabs are connected to the connector.
 - Pull (A) the tube and the quick connector (1) to check they are securely connected.

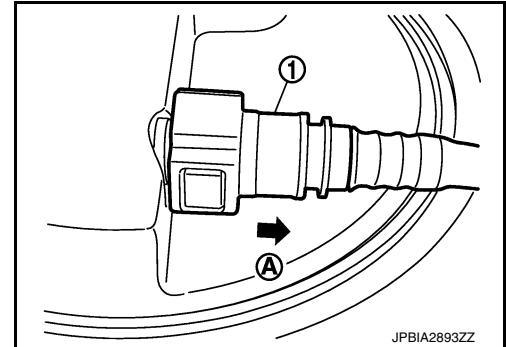

Inspection

INSPECTION AFTER INSTALLATION

Use the following procedure to check for fuel leaks.

1. Turn ignition switch "ON" (with engine stopped), then check connections for leaks by applying fuel pressure to fuel piping.
2. Start engine and let it idle and check there are no fuel leaks at the fuel system connections.

INFOID:000000012788279

FUEL TANK

< REMOVAL AND INSTALLATION >

FUEL TANK

Exploded View

INFOID:000000012788280

FOR CALIFORNIA

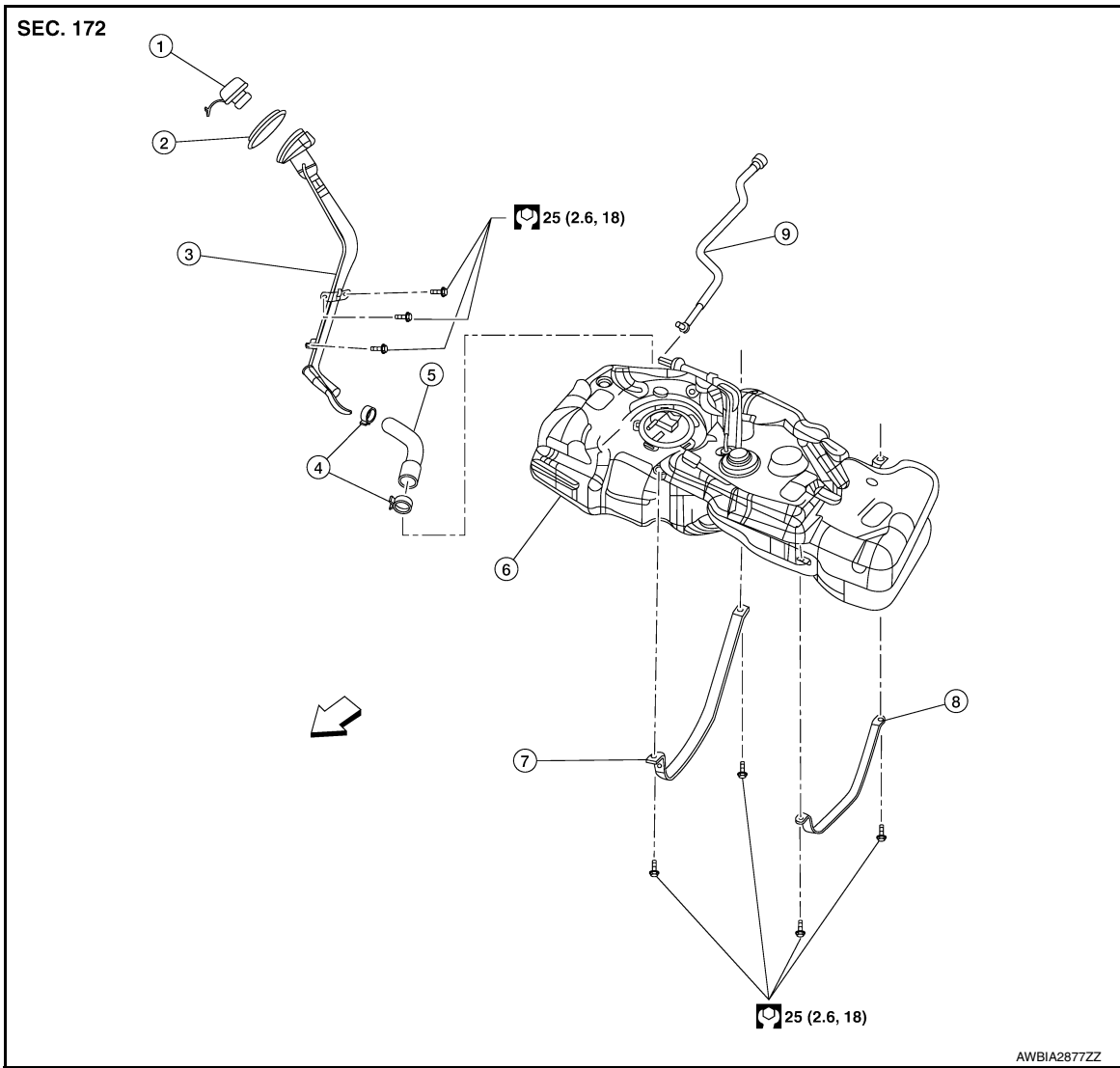

- | | | |
|---------------------------------|---------------------------------|---------------------|
| 1. Fuel filler cap | 2. Grommet | 3. Fuel filler tube |
| 4. Clamp | 5. Fuel filler hose | 6. Fuel tank |
| 7. Fuel tank mounting band (RH) | 8. Fuel tank mounting band (LH) | 9. Vent hose |

↔ Front

A
FL
C
D
E
F
G
H
I
J
K
L
M
N
O
P

FUEL TANK

< REMOVAL AND INSTALLATION >

EXCEPT FOR CALIFORNIA

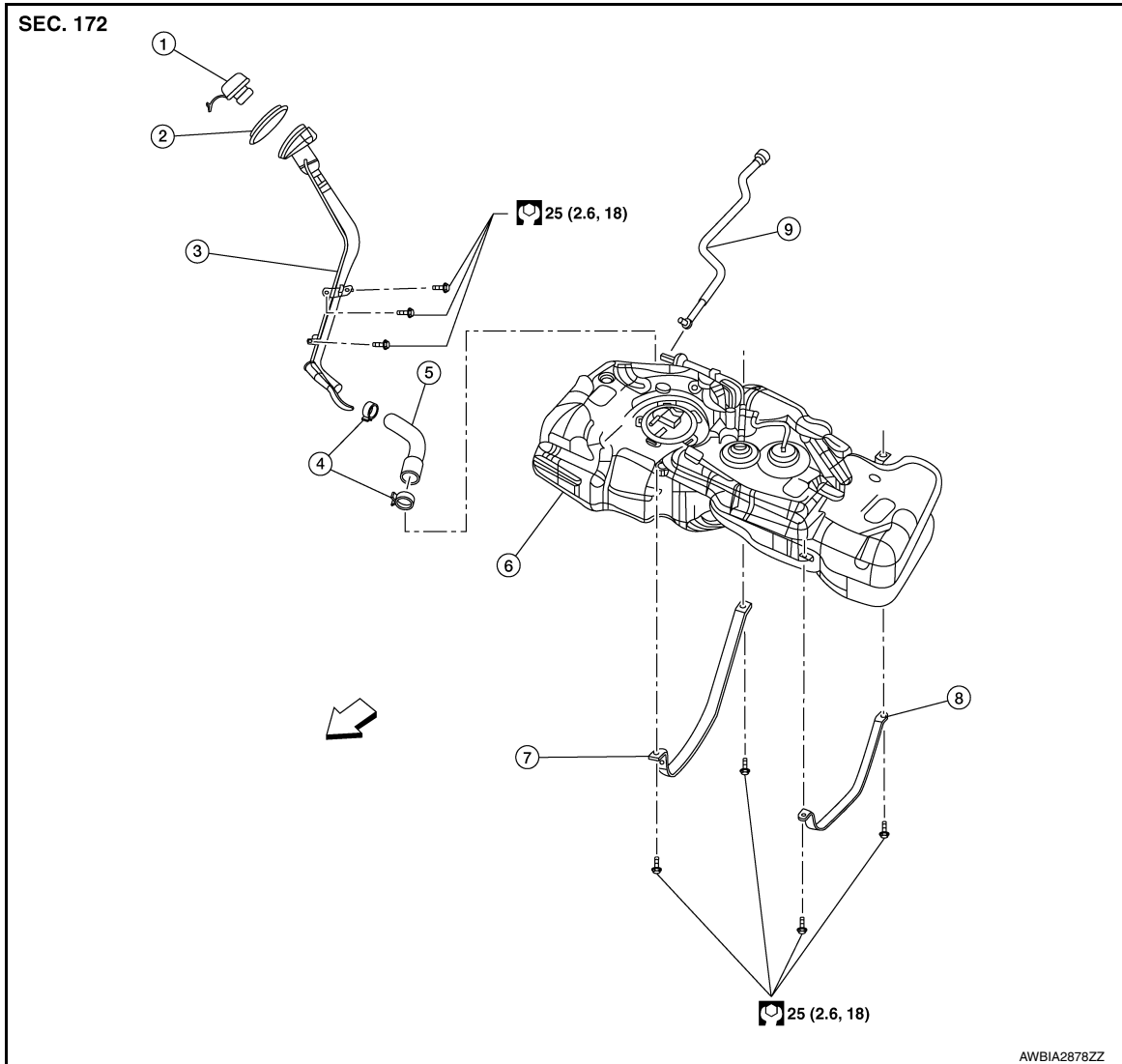

- | | | |
|---------------------------------|---------------------------------|---------------------|
| 1. Fuel filler cap | 2. Grommet | 3. Fuel filler tube |
| 4. Clamp | 5. Fuel filler hose | 6. Fuel tank |
| 7. Fuel tank mounting band (RH) | 8. Fuel tank mounting band (LH) | 9. Vent hose |

⇐ Front

Removal and Installation

INFOID:000000012788281

WARNING:

Be sure to read "General Precautions" when working on the fuel system. Refer to [FL-2, "General Precaution"](#).

NOTE:

When removing components such as hoses, tubes/lines, etc., cap or plug openings to prevent fluid from spilling.

REMOVAL

1. Open fuel filler lid.
2. Open filler cap and release the pressure inside fuel tank.
3. Release the fuel pressure from the fuel lines. Refer to [EC-147, "Work Procedure"](#).

FUEL TANK

< REMOVAL AND INSTALLATION >

4. Check the fuel level with the vehicle on a level surface. If the fuel gauge indicates more than the level as shown (1/2 full), drain the fuel from the fuel tank until the fuel gauge indicates a level at or below as shown (1/2 full).
 - In case the fuel pump does not operate, use the following procedure.
 - a. Insert fuel tubing of less than 25 mm (0.98 in) diameter into the fuel filler tube through the fuel filler opening to drain fuel from the fuel filler tube.
 - b. Disconnect the fuel filler hose from the fuel filler tube.
 - c. Insert fuel tubing into the fuel tank through the fuel filler hose to drain fuel from the fuel tank.
 - As a guide, if the fuel tank is full the fuel level reaches or is less than the level on the fuel gauge as shown, when approximately 25 ℓ (6-5/8 US gal, 5-1/2 Imp gal) of fuel is drained from a full fuel tank.
5. Disconnect park brake rear cables and position the rear park brake cables aside. Refer to [PB-7, "Exploded View"](#).
6. Remove the tunnel stay, front exhaust tube and sub muffler. Refer to [EX-6, "Removal and Installation"](#).
7. Remove trunk floor carpet. Refer to [INT-43, "TRUNK SIDE FINISHER : Removal and Installation"](#).
8. Remove rear seat cushion assembly. Refer to [SE-36, "Removal and Installation - Seat Cushion Assembly"](#).
9. Remove inspection hole cover.

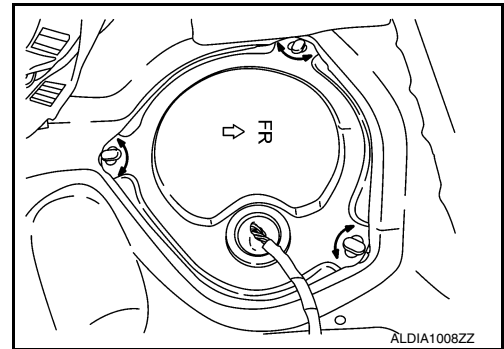
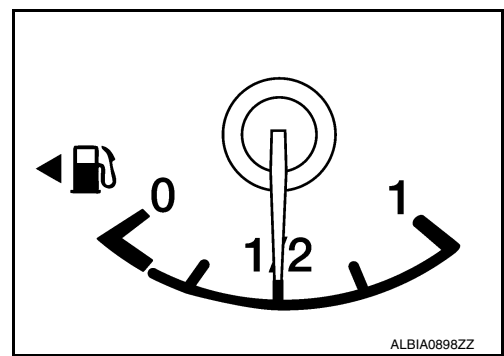

10. Disconnect harness connector (1), fuel feed hose (3), and quick connector (4) from fuel level sensor unit, fuel filter and fuel pump assembly (2).

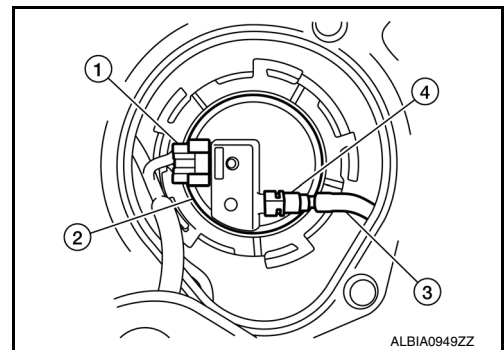

- Remove quick connector in the following procedures.
 - Pinch quick connector square-part (A) with your fingers, and pull out the quick connector (1) by hand.
 - If quick connector and tube on sender unit are stuck, push and pull several times until they move, and pull out.

CAUTION:

- **Quick connector can be removed when the tabs are completely depressed. Do not twist it more than necessary.**
- **Do not use any tools to disconnected quick connector.**
- **Keep resin tube away from heat. Be especially careful when welding near the resin tube.**
- **Prevent acid liquid such as battery electrolyte, etc. from getting on resin tube.**

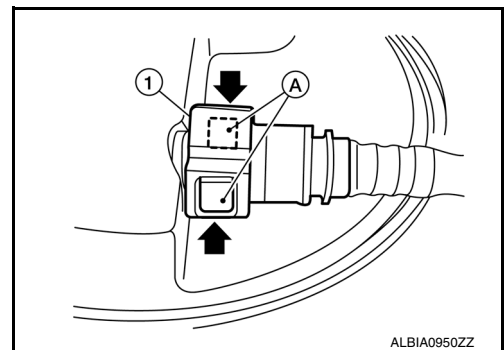

A
FL
C
D
E
F
G
H
I
J
K
L
M
N
O
P

FUEL TANK

< REMOVAL AND INSTALLATION >

- Do not bend or twist resin tube during installation and disconnection.
- To keep the connecting portion clean and to avoid damage and foreign materials, cover them completely with plastic bags (A) or something similar.
- Do not insert plug, preventing damage on O-ring in quick connector.

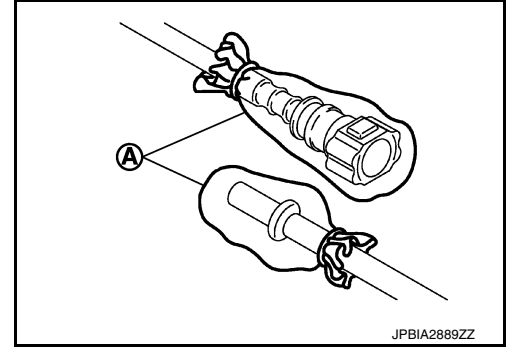

11. Remove the tunnel stay and center exhaust tube, without muffler. Refer to [EX-5, "Exploded View"](#).
12. Remove the fuel tank protector.
13. Disconnect the rear cables and position the rear cables aside. Refer to [PB-9, "Removal and Installation - Drum Brake"](#) (Drum brake) or [PB-9, "Removal and Installation - Disc Brake"](#) (Disc brake).
14. Disconnect return line from filler hose.
15. Remove fuel filler hose.
16. Disconnect vent hose from fuel tank.
17. Support the center of the fuel tank (1) with a suitable jack (B) and secure the fuel tank to the jack.

CAUTION:

- Securely support the fuel tank with a piece of wood (A).
- Fuel tank may be in an unstable condition, due to the shape of the fuel tank bottom. Be sure to secure tank at all times.

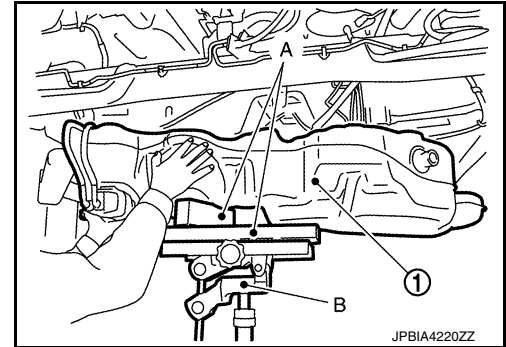

18. Remove fuel tank mounting bands (RH/LH).
19. Lower suitable jack carefully to remove fuel tank while holding it by hand.

CAUTION:

Fuel tank may be in an unstable condition, due to the shape of the fuel tank bottom. Be sure to secure tank at all times.

20. Remove lock ring for fuel level sensor unit, fuel filter and fuel pump assembly with Tool (A) by turning counterclockwise (if necessary).

Tool number (A) : KV991J0090 (J-46214) (shown)
: KV101207S0 (—)

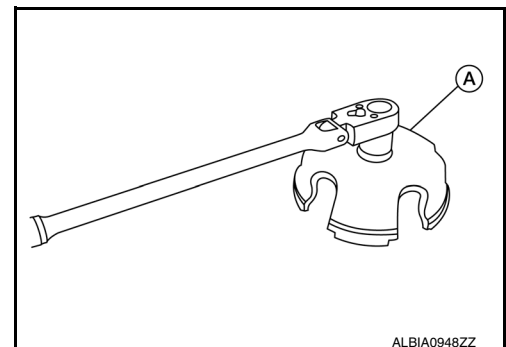

21. Remove fuel level sensor unit, fuel filter and fuel pump assembly (if necessary).

CAUTION:

- Do not bend float arm during removal.
- Do not pollute the inside by residue fuel. Draw out avoiding inclination by supporting with a cloth.
- Do not cause impacts such by dropping when handling components.

FUEL TANK

< REMOVAL AND INSTALLATION >

INSTALLATION

Installation is in the reverse order of removal.

NOTE:

- Do not use any lubrication to aid with the installation of tubes and hoses.
- Before tightening the fuel tank mounting bands, install the filler hose to the length of 35 mm (1.38 in), all other hoses to 25 mm (0.98 in).
- Tighten the clamps until the head of the bolt is on the paint mark on the clamp band.
- Tight mounting band bolts 1 and 2 to specification. Hand tighten mounting band bolt 3. While pushing the tank in the direction shown, tighten mounting band bolt 4 to specification then mounting band bolt 3.

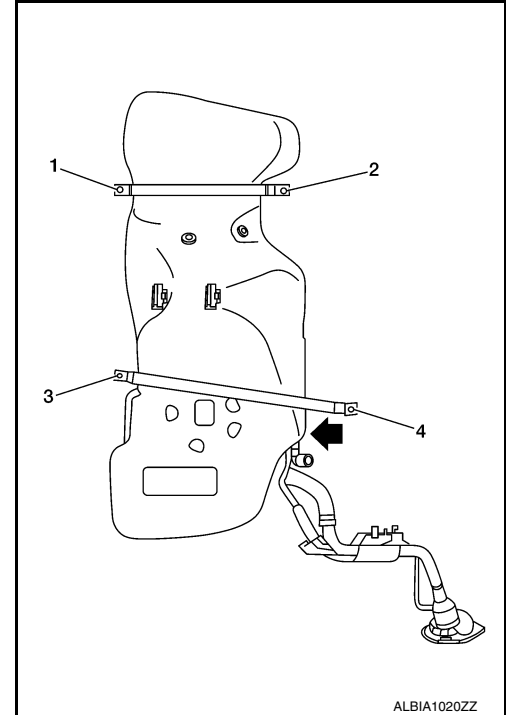

Quick Connector

Connect quick connector as follows:

1. Check the connection for damage or any foreign materials.
2. Align the connector with the tube, then insert the connector straight into the tube until a click sound is heard.
3. After connecting, check that the connection is secure by following method.
 - Visually confirm that the two tabs are connected to the connector.
 - Pull (A) the tube and the quick connector (1) to check they are securely connected.

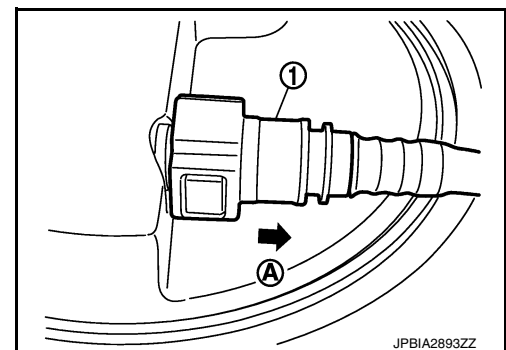

Inspection

INSPECTION AFTER INSTALLATION

Use the following procedure to check for fuel leaks.

1. Turn ignition switch "ON" (with engine stopped), then check connections for leaks by applying fuel pressure to fuel piping.
2. Start engine and let it idle and check there are no fuel leaks at the fuel system connections.

EVAP CANISTER

< REMOVAL AND INSTALLATION >

EVAP CANISTER

Exploded View

INFOID:000000012788283

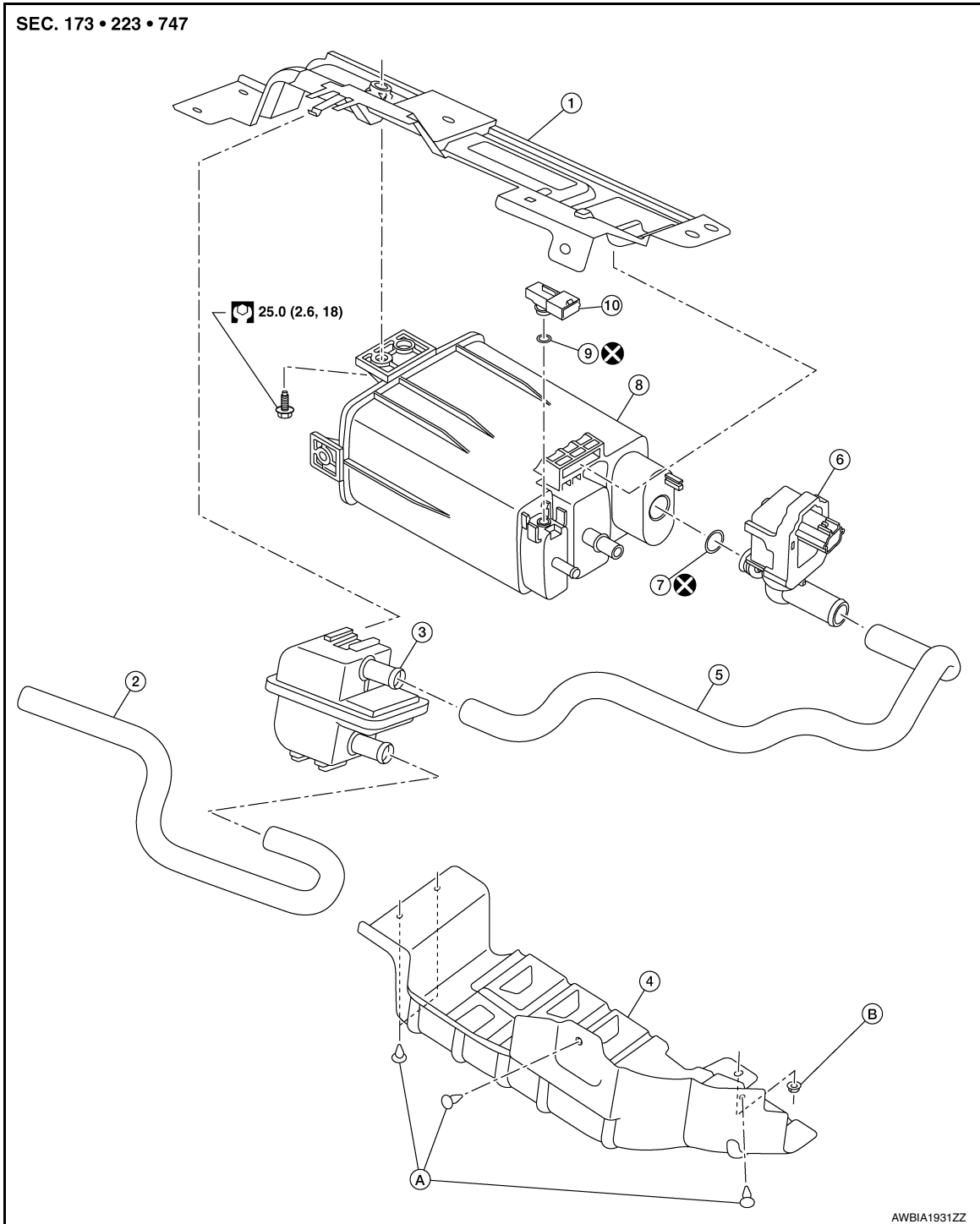

- | | | |
|---|------------------------------------|-------------------------------------|
| 1. EVAP canister bracket | 2. EVAP canister filter drain hose | 3. EVAP canister filter |
| 4. EVAP canister protector | 5. EVAP hose | 6. EVAP canister vent control valve |
| 7. O-ring | 8. EVAP canister | 9. O-ring |
| 10. EVAP canister control pressure sensor | A. Clip | B. Nut |

EVAP CANISTER

< REMOVAL AND INSTALLATION >

Removal and Installation

INFOID:000000012788284

EVAP CANISTER

Removal

1. Remove EVAP canister protector.
2. Disconnect the harness connector from EVAP canister control pressure sensor.
3. Remove the EVAP canister control pressure sensor and O-ring (if necessary).
CAUTION:
Do not reuse O-ring.
4. Disconnect EVAP canister purge hose.
5. Disconnect fuel tank EVAP breather hose.
6. Disconnect the harness connector from EVAP vent control valve.
7. Disconnect the EVAP vent control valve hose.
8. Remove the EVAP canister bolt.
9. Remove the EVAP canister.
10. Remove the EVAP vent control valve and O-ring (if necessary).
CAUTION:
Do not reuse O-ring.

Installation

Installation is in the reverse order of removal.

CAUTION:
Do not reuse O-ring.

EVAP CANISTER CONTROL PRESSURE SENSOR

Removal

1. Remove EVAP canister protector.
2. Disconnect the harness connector (1) from EVAP control pressure sensor.
3. Remove the EVAP canister control pressure sensor and O-ring.
CAUTION:
Do not reuse O-ring.

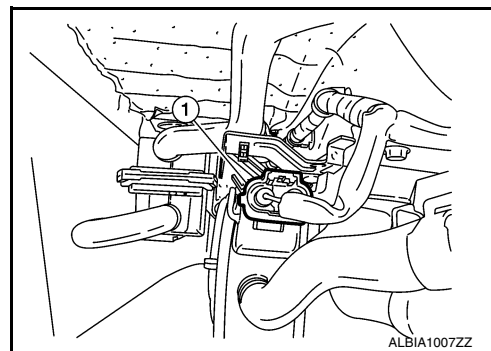

Installation

Installation is in the reverse order of removal.

CAUTION:
Do not reuse O-ring.

EVAP CANISTER VENT CONTROL VALVE

Removal

1. Remove EVAP canister protector.
2. Disconnect the harness connector from EVAP vent control valve.
3. Disconnect the EVAP vent control valve hose.

EVAP CANISTER

< REMOVAL AND INSTALLATION >

- Turn EVAP canister vent control valve counterclockwise.
(A): Clock
(B): Unclock
- Remove the EVAP canister vent control valve and O-ring.
CAUTION:
Do not reuse O-ring.

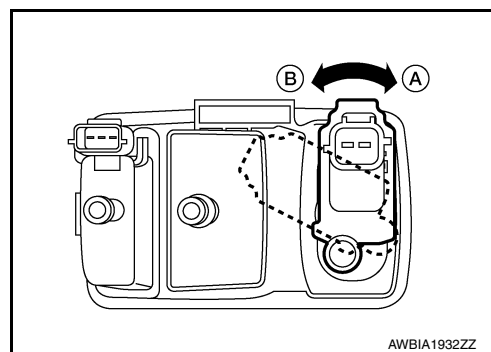

Installation

Installation is in the reverse order of removal.

CAUTION:

Do not reuse O-ring.

EVAP CANISTER FILTER

Removal

- Remove EVAP canister protector.
- Disconnect the EVAP canister filter drain hose (1).
- Disconnect the EVAP hose (2).
- Remove the EVAP canister filter.

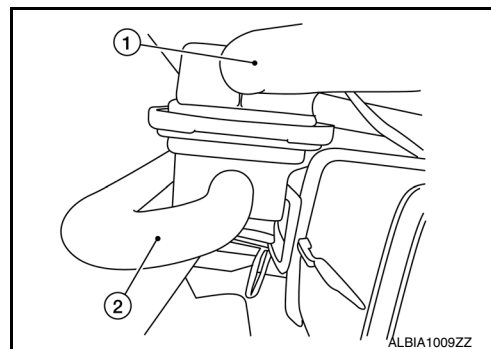

Installation

Installation is in the reverse order of removal.

FUEL LEVEL SENSOR UNIT

< DISASSEMBLY AND ASSEMBLY >

DISASSEMBLY AND ASSEMBLY

FUEL LEVEL SENSOR UNIT

Exploded View

INFOID:000000012788285

A

FL

Fuel Level Sensor Unit

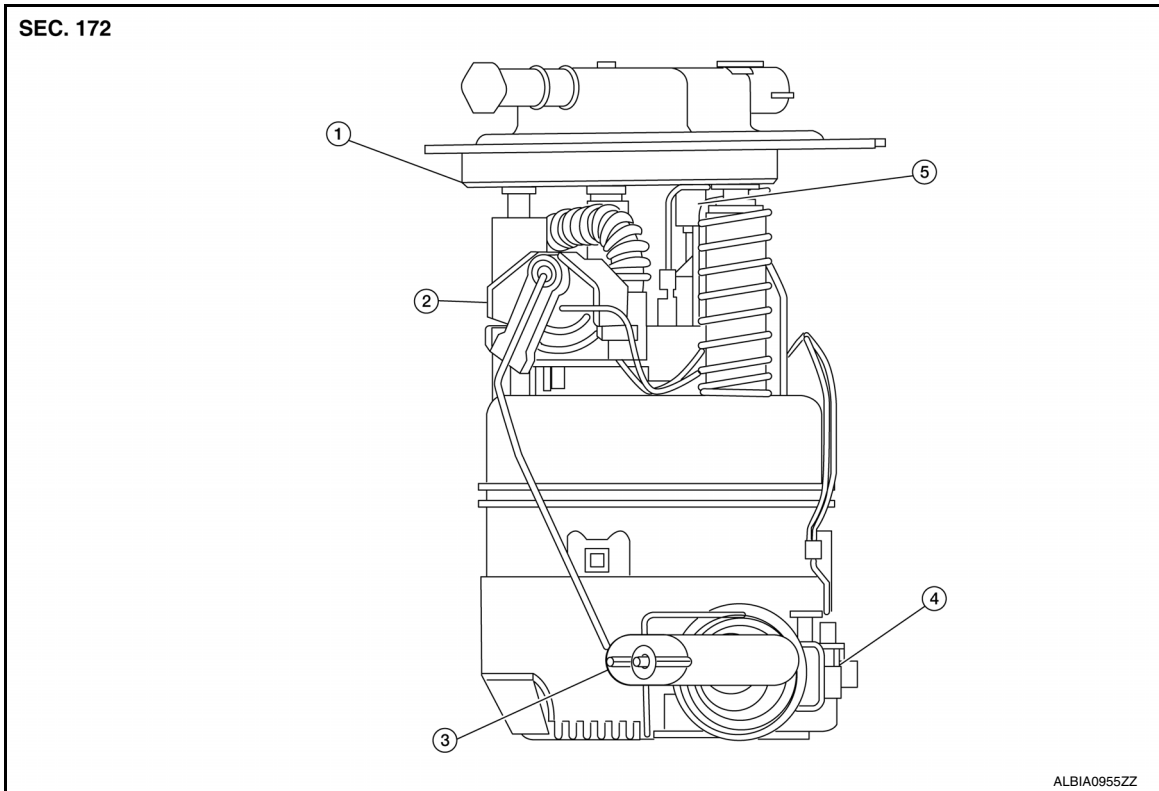

C

D

E

F

G

H

I

J

- 1. Fuel filter and pump assembly
- 2. Fuel level sensor unit
- 3. Float arm assembly
- 4. Fuel tank temperature sensor
- 5. Fuel level sensor unit/fuel tank temperature sensor harness connector

K

Disassembly and Assembly

INFOID:000000012788286

DISASSEMBLY

1. Disconnect the harness connector (1) from fuel level sensor unit/fuel tank temperature sensor.

NOTE:

Hold connector with your fingers, because there is no tab for releasing stopper. Pull it out straight downward.

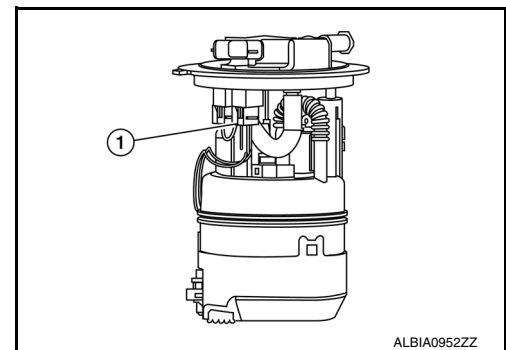

L

M

N

O

P

FUEL LEVEL SENSOR UNIT

< DISASSEMBLY AND ASSEMBLY >

2. Remove fuel tank temperature sensor (2) from fuel filter and fuel pump assembly (1).

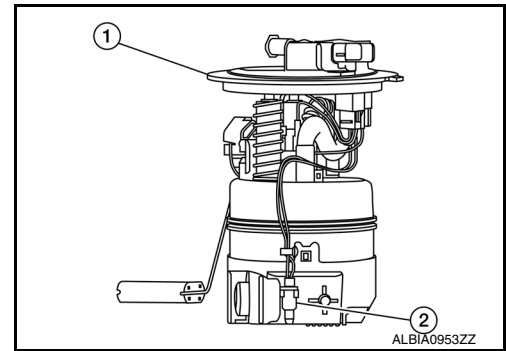

3. Remove fuel level sensor unit (3) from fuel filter and fuel pump assembly (1) using a suitable tool (2).

CAUTION:

- Be careful not to damage the fuel level sensor unit.
- Do not disassemble fuel filter and fuel pump assembly.

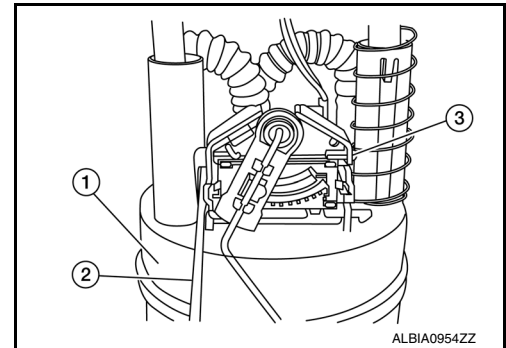

ASSEMBLY

1. Check for damage of fuel level sensor unit installation position on the side of fuel filter and pump assembly.
2. Slide fuel level sensor unit until it aligns to installation groove, then insert it until it stops.
 - After inserting, apply force in reverse direction (removal direction) to ensure it cannot be pulled out.
3. Connect fuel level sensor unit/fuel tank temperature sensor harness connector.

INSPECTION AFTER INSTALLATION

Use the following procedure to check for fuel leaks.

1. Turn ignition switch "ON" (with engine stopped), then check connections for leaks by applying fuel pressure to fuel piping.
2. Start engine and let it idle and check there are no fuel leaks at the fuel system connections.

SERVICE DATA AND SPECIFICATIONS (SDS)

< SERVICE DATA AND SPECIFICATIONS (SDS)

SERVICE DATA AND SPECIFICATIONS (SDS)

SERVICE DATA AND SPECIFICATIONS (SDS)

Fuel Tank

INFOID:0000000012788287

A

FL

Standard and Limit

Unit: ℓ (US gal, Imp gal)

Fuel tank capacity	Approx. 50.0 (13-1/4, 11)
Fuel recommendation	Refer to MA-12, "Fluids and Lubricants"

C

D

E

F

G

H

I

J

K

L

M

N

O

P