

SECTION **FAX**
FRONT AXLE

A
B
C

FAX

CONTENTS

PRECAUTION	2	On-Vehicle Inspection and Service	5	F
PRECAUTIONS	2	UNIT REMOVAL AND INSTALLATION	6	
Precaution for Supplemental Restraint System (SRS) "AIR BAG" and "SEAT BELT PRE-TENSIONER"	2	WHEEL HUB	6	G
Precaution	2	Removal and Installation	6	
PREPARATION	3	DRIVE SHAFT	8	H
PREPARATION	3	Removal and Installation	8	
Special Service Tool	3	UNIT DISASSEMBLY AND ASSEMBLY ...	10	I
Commercial Service Tool	3	DRIVE SHAFT	10	
SYMPTOM DIAGNOSIS	4	Disassembly and Assembly	10	J
NOISE, VIBRATION, AND HARSHNESS (NVH) TROUBLESHOOTING	4	SERVICE DATA AND SPECIFICATIONS (SDS)	15	K
NVH Troubleshooting Chart	4	SERVICE DATA AND SPECIFICATIONS (SDS)	15	
PERIODIC MAINTENANCE	5	Wheel Bearing	15	L
WHEEL HUB	5	Drive Shaft	15	
		Boot Bands	15	M

E
F
G
H
I
J
K
L
M
N
O
P

PRECAUTIONS

< PRECAUTION >

PRECAUTION

PRECAUTIONS

Precaution for Supplemental Restraint System (SRS) "AIR BAG" and "SEAT BELT PRE-TENSIONER"

INFOID:000000006161618

The Supplemental Restraint System such as "AIR BAG" and "SEAT BELT PRE-TENSIONER", used along with a front seat belt, helps to reduce the risk or severity of injury to the driver and front passenger for certain types of collision. This system includes seat belt switch inputs and dual stage front air bag modules. The SRS system uses the seat belt switches to determine the front air bag deployment, and may only deploy one front air bag, depending on the severity of a collision and whether the front occupants are belted or unbelted. Information necessary to service the system safely is included in the SR and SB section of this Service Manual.

WARNING:

- **To avoid rendering the SRS inoperative, which could increase the risk of personal injury or death in the event of a collision which would result in air bag inflation, all maintenance must be performed by an authorized NISSAN/INFINITI dealer.**
- **Improper maintenance, including incorrect removal and installation of the SRS, can lead to personal injury caused by unintentional activation of the system. For removal of Spiral Cable and Air Bag Module, see the SR section.**
- **Do not use electrical test equipment on any circuit related to the SRS unless instructed to in this Service Manual. SRS wiring harnesses can be identified by yellow and/or orange harnesses or harness connectors.**

PRECAUTIONS WHEN USING POWER TOOLS (AIR OR ELECTRIC) AND HAMMERS

WARNING:

- **When working near the Airbag Diagnosis Sensor Unit or other Airbag System sensors with the Ignition ON or engine running, DO NOT use air or electric power tools or strike near the sensor(s) with a hammer. Heavy vibration could activate the sensor(s) and deploy the air bag(s), possibly causing serious injury.**
- **When using air or electric power tools or hammers, always switch the Ignition OFF, disconnect the battery, and wait at least 3 minutes before performing any service.**

Precaution

INFOID:000000006161619

Observe the following precautions when disassembling and servicing the wheel hub and drive shafts.

- Perform work in a location which is as dust-free as possible.
- Before disassembling and servicing, clean the outside of parts.
- Prevention of the entry of foreign objects must be taken into account during disassembly of the component parts.
- Disassembled parts must be carefully reassembled in the correct order. If work is interrupted, a clean cover must be placed over parts.
- Paper shop cloths must be used. Fabric shop cloths must not be used because of the danger of lint adhering to parts.
- Disassembled parts (except for rubber parts) should be cleaned with a suitable solvent which shall be removed by blowing with air or wiping with paper shop cloths.

PREPARATION

< PREPARATION >

PREPARATION

PREPARATION

Special Service Tool

INFOID:000000006161620

The actual shapes of Kent-Moore tools may differ from those of special service tools illustrated here.

Tool number (Kent-Moore No.) Tool name	Description
ST29020001 (J-24319-01) Gear arm puller	Removing ball joint for steering knuckle a: 34 mm (1.34 in) b: 6.5 mm (0.256 in) c: 61.5 mm (2.421 in)
KV40107300 (—) Boot band crimping tool	Installing boot bands

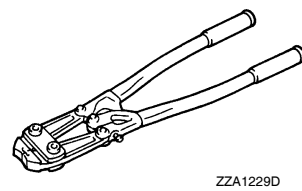
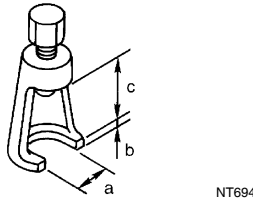

Commercial Service Tool

INFOID:000000006161621

Tool name	Description
Power tools	Removing bolts and nuts

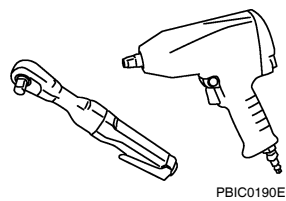

A
B
C
FAX
E
F
G
H
I
J
K
L
M
N
O
P

NOISE, VIBRATION, AND HARSHNESS (NVH) TROUBLESHOOTING

< SYMPTOM DIAGNOSIS >

SYMPTOM DIAGNOSIS

NOISE, VIBRATION, AND HARSHNESS (NVH) TROUBLESHOOTING

NVH Troubleshooting Chart

INFOID:000000006161622

Use the chart below to help you find the cause of the symptom. If necessary, repair or replace these parts.

			Possible cause and SUSPECTED PARTS															
Reference page			FAX-8	FAX-10	FAX-10	FAX-8	—	FAX-5	DLN-130, "NVH Troubleshooting Chart" (2F1310)	DLN-163, "NVH Troubleshooting Chart"	Refer to DRIVE SHAFT in this chart.	Refer to WHEEL HUB in this chart.	RSU-4, "NVH Troubleshooting Chart"	WT-42, "NVH Troubleshooting Chart"	WT-42, "NVH Troubleshooting Chart"	BR-5, "NVH Troubleshooting Chart"	ST-5, "NVH Troubleshooting Chart"	
Symptom			Excessive joint angle	Joint sliding resistance	Imbalance	Improper installation, looseness	Parts interference	Wheel bearing damage	PROPELLER SHAFT	FRONT FINAL DRIVE	DRIVE SHAFT	WHEEL HUB	SUSPENSION	TIRES	ROAD WHEEL	BRAKES	STEERING	
DRIVE SHAFT	Noise, Vibration	×	×						×	×		×	×	×	×	×	×	
		Shake	×		×				×			×	×	×	×	×	×	×
	WHEEL HUB	Noise				×	×		×	×	×		×	×	×	×	×	×
		Shake				×	×		×		×		×	×	×	×	×	×
		Vibration				×	×		×		×		×	×				×
		Shimmy				×	×						×	×	×	×	×	×
		Shudder				×							×	×	×	×	×	×
Poor quality ride or handling				×	×	×						×	×	×				

×: Applicable

WHEEL HUB

< PERIODIC MAINTENANCE >

PERIODIC MAINTENANCE

WHEEL HUB

On-Vehicle Inspection and Service

INFOID:000000006161623

Make sure the mounting conditions (looseness, backlash) of each component and component status (wear, damage) are normal.

WHEEL BEARING INSPECTION

- Move wheel hub in the axial direction by hand. Make sure there is no looseness of wheel bearing.

Axial end play limit : Refer to [FAX-15, "Wheel Bearing"](#).

- Rotate wheel hub and make sure there is no unusual noise or other irregular conditions. If there are any irregular conditions, replace wheel hub and bearing assembly.

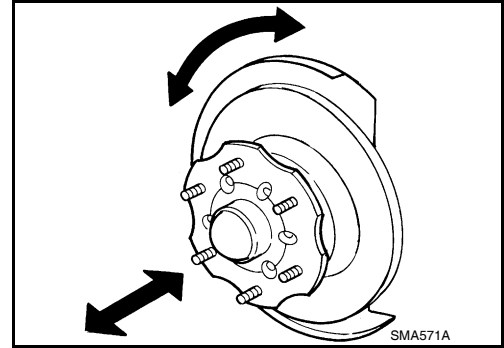

A

B

C

FAX

E

F

G

H

I

J

K

L

M

N

O

P

WHEEL HUB

< UNIT REMOVAL AND INSTALLATION >

UNIT REMOVAL AND INSTALLATION

WHEEL HUB

Removal and Installation

INFOID:000000006161624

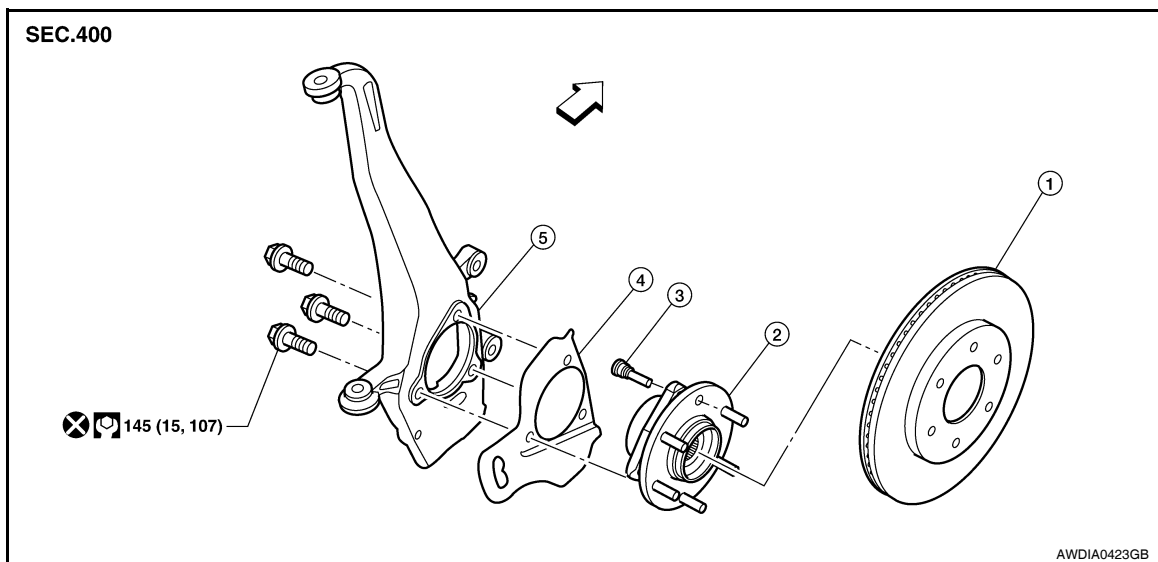

- | | | |
|-----------------|-----------------------------------|---------------|
| 1. Disc rotor | 2. Wheel hub and bearing assembly | 3. Wheel stud |
| 4. Splash guard | 5. Steering knuckle | ⇐ Front |

REMOVAL

1. Remove wheel and tire using power tool.
2. Remove engine undercover if equipped, using power tool.
3. Without disassembling the hydraulic lines, remove the torque member bolts using power tool. Then reposition brake caliper aside with wire. Refer to [BR-32, "Removal and Installation of Brake Caliper and Rotor"](#).

NOTE:

Do not press brake pedal while brake caliper is removed.

4. Put alignment mark on disc rotor and wheel hub and bearing assembly, then remove disc rotor.

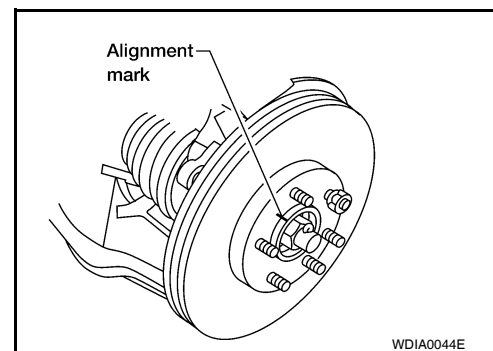

5. Remove wheel sensor. Refer to [BRC-113, "Removal and Installation"](#).
 - Inspect the wheel sensor O-ring, replace the wheel sensor assembly if damaged.
 - Clean the wheel sensor hole and mounting surface with a suitable brake cleaner and clean lint-free shop rag. Be careful that dirt and debris do not enter the axle bearing area.
 - Apply a coat of suitable grease to the wheel sensor O-ring and mounting hole.

CAUTION:

Do not pull on the wheel sensor harness.

6. On 4WD models, remove drive shaft from steering knuckle. Refer to [FAX-8, "Removal and Installation"](#).
7. Remove wheel hub and bearing assembly bolts using power tool.

WHEEL HUB

< UNIT REMOVAL AND INSTALLATION >

8. Remove splash guard and wheel hub and bearing assembly from steering knuckle.

INSPECTION AFTER REMOVAL

Check for deformity, cracks and damage on each part, replace if necessary.

INSTALLATION

Installation is in the reverse order of removal.

- Use new bolts when installing the wheel hub and bearing assembly.
- Tighten drive shaft nut to specification. Refer to [FAX-8, "Removal and Installation"](#).
- When installing disc rotor on wheel hub and bearing assembly, position the disc rotor according to alignment mark.
(When not using the alignment mark, refer to [BR-32, "Removal and Installation of Brake Caliper and Rotor"](#).)
- When installing wheel and tire. Refer to [WT-50, "Road Wheel"](#).

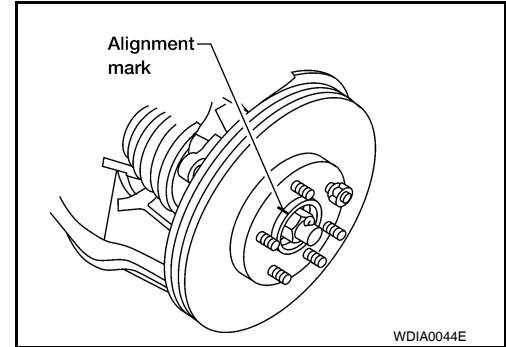

A
B
C
FAX
E
F
G
H
I
J
K
L
M
N
O
P

DRIVE SHAFT

< UNIT REMOVAL AND INSTALLATION >

DRIVE SHAFT

Removal and Installation

INFOID:000000006161625

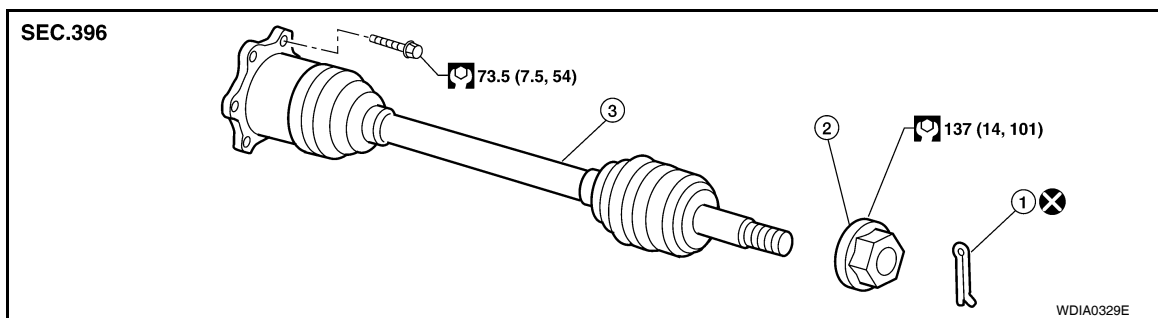

1. Cotter pin
2. Drive shaft nut
3. Drive shaft

REMOVAL

1. Remove wheel and tire using power tool.
2. Remove engine under cover using power tool.
3. Remove wheel sensor harness from mount on knuckle.
CAUTION:
Do not pull on wheel sensor harness.
4. Without disassembling the hydraulic lines, remove brake caliper using power tool. Reposition it aside with wire. Refer to [BR-32. "Removal and Installation of Brake Caliper and Rotor"](#).
NOTE:
Avoid depressing brake pedal while brake caliper is removed.
5. Remove coil spring and shock absorber assembly using power tool. Refer to [FSU-20. "Removal and Installation"](#).
6. Separate upper link ball joint stud from steering knuckle using Tool.
• Support lower link with jack.

Tool number : ST29020001 (J-24319-01)

7. Remove cotter pin, then remove drive shaft nut.
8. Remove drive shaft bolts from front final drive.
9. Remove drive shaft from wheel hub and bearing assembly.

CAUTION:

- **When removing drive shaft, do not apply an excessive angle to drive shaft joint. Also be careful not to excessively extend slide joint.**

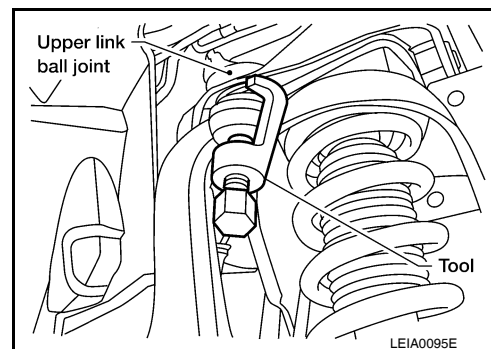

INSPECTION AFTER REMOVAL

- Move joint up, down, left, right, and in axial direction. Check for any rough movement or significant looseness.
- Check boot for cracks or other damage, and for grease leakage.
- If damaged, disassemble drive shaft to verify damage, and repair or replace as necessary.

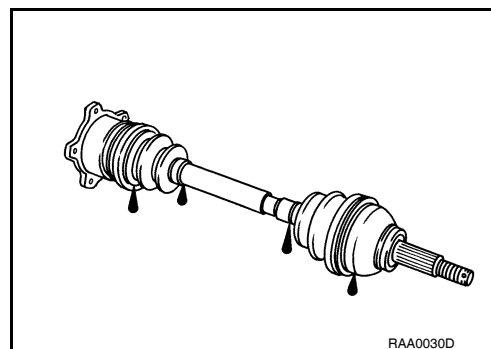

DRIVE SHAFT

< UNIT REMOVAL AND INSTALLATION >

INSTALLATION

Installation is in the reverse order of removal.

- Tighten wheel nuts to specification. Refer to [WT-46, "Adjustment"](#).

A

B

C

FAX

E

F

G

H

I

J

K

L

M

N

O

P

DRIVE SHAFT

< UNIT DISASSEMBLY AND ASSEMBLY >

UNIT DISASSEMBLY AND ASSEMBLY

DRIVE SHAFT

Disassembly and Assembly

INFOID:000000006161626

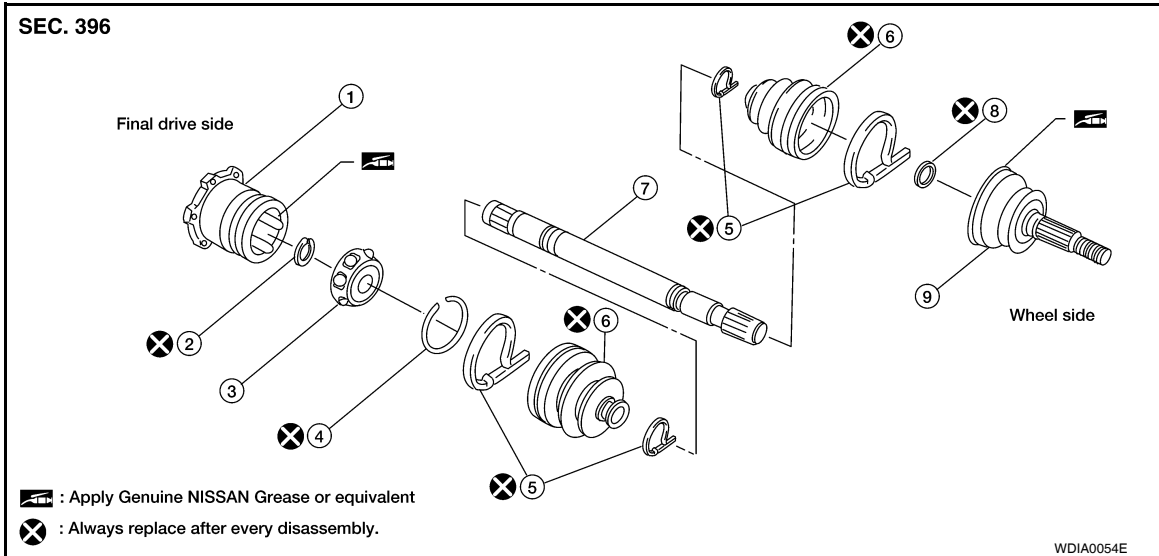

- | | | |
|--------------------------|--------------|-----------------------------------------------|
| 1. Sliding joint housing | 2. Snap ring | 3. Ball cage, steel ball, inner race assembly |
| 4. Stopper ring | 5. Boot band | 6. Boot |
| 7. Drive shaft | 8. Circlip | 9. Joint sub-assembly |

DISASSEMBLY

Final Drive Side

1. Mount the drive shaft in a vise.

CAUTION:

When mounting the drive shaft in a vise, use copper or aluminum plates between the vise and the drive shaft.

2. Remove the boot bands.
3. Remove the stopper ring with suitable tool as shown, and pull the housing off.

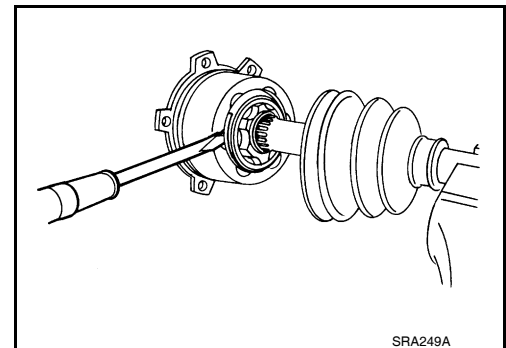

DRIVE SHAFT

< UNIT DISASSEMBLY AND ASSEMBLY >

4. Remove the snap ring, then remove the ball cage, steel ball, inner race assembly from the drive shaft.

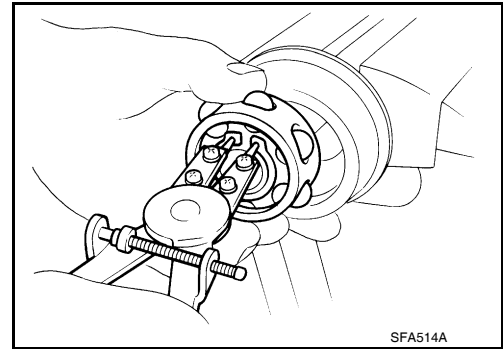

5. Remove the boot from the drive shaft.
6. Remove any old grease on the housing using paper towels.

Wheel Side

1. Mount the drive shaft in a vise.

CAUTION:

When mounting the drive shaft in a vise, use copper or aluminum plates between the vise and the drive shaft.

2. Remove the boot bands, then remove the boot from the joint sub-assembly.
3. Screw a suitable drive shaft puller 30 mm (1.18 in) or more into the threaded part of the joint sub-assembly. Pull the joint sub-assembly off of the drive shaft as shown.

NOTE:

Align the sliding hammer and drive shaft and remove the joint sub-assembly by pulling directly.

CAUTION:

- If the joint sub-assembly cannot be removed after five or more attempts, replace the drive shaft and joint sub-assembly as a set.

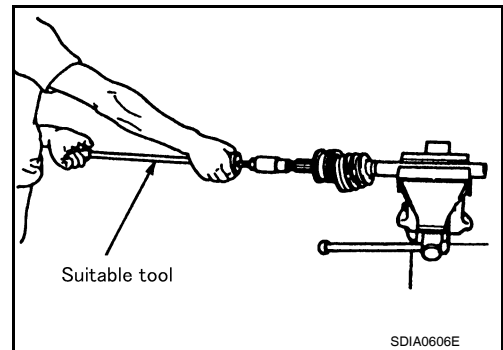

4. Remove the boot from the drive shaft.
5. Remove the circlip from the drive shaft.
6. While rotating the ball cage, remove any old grease from the joint sub-assembly using paper towels.

INSPECTION AFTER DISASSEMBLY

Drive Shaft

- Replace the drive shaft if there is any runout, cracking, or other damage.

Joint Sub-assembly

- Check for any rough rotation or unusual axial looseness.
- Clean any foreign material from inside the joint sub-assembly.
- Check for any compression scars, cracks, or fractures.

CAUTION:

If any defective conditions are found in the joint sub-assembly components, replace the entire joint sub-assembly.

Sliding Joint Side Housing

- Check for any compression scars, cracks, fractures, or unusual wear on the ball rolling surface.
- Check for any damage to the drive shaft screws.
- Check for any deformation of the boot installation components.

Ball Cage

- Check the sliding surface for any compression scars, cracks, or fractures.

Steel Ball

- Check for any compression scars, cracks, fractures, or unusual wear.

Inner Race

DRIVE SHAFT

< UNIT DISASSEMBLY AND ASSEMBLY >

- Check the ball sliding surface for any compression scars, cracks, or fractures.
- Check for any damage to the serrated part.

CAUTION:

If any defective conditions are found, install a new housing, ball cage, steel ball, and inner race as a set.

ASSEMBLY

Final Drive Side

1. Wrap the serrated part of the drive shaft with tape. Install the boot band and boot to drive shaft.

NOTE:

Discard the old boot band and boot and use a new one for assembly.

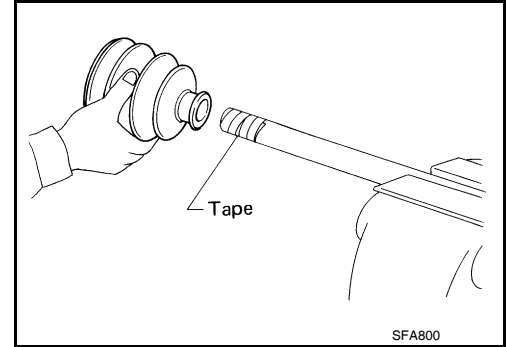

2. Remove the tape wound around the serrated part of the drive shaft.

3. Install the ball cage, steel ball, and inner race assembly on the drive shaft, and secure them tightly using the snap ring.

NOTE:

Discard the old snap ring and use a new one for assembly.

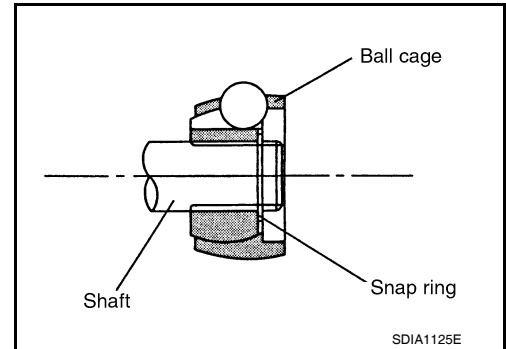

4. Insert the specified quantity of Genuine NISSAN Grease or equivalent, onto the housing (indicated by * marks), and install it onto shaft. Refer to [MA-21, "FOR NORTH AMERICA : Fluids and Lubricants"](#) (United States and Canada), [MA-22, "FOR MEXICO : Fluids and Lubricants"](#) (Mexico).

Grease capacity : Refer to [FAX-15, "Drive Shaft"](#).

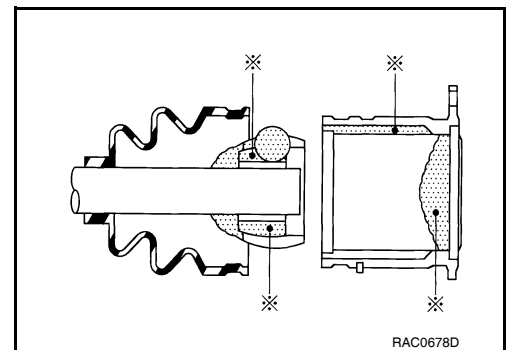

5. Install the stopper ring onto the housing.
6. After installation, pull on the shaft to check engagement between the sliding joint and the stopper ring.

DRIVE SHAFT

< UNIT DISASSEMBLY AND ASSEMBLY >

7. Install the boot securely into the grooves (indicated by * marks) as shown.

CAUTION:

If there is grease on boot mounting surfaces (indicated by * marks) of shaft and housing, boot may come off. Remove all grease from surfaces.

8. Check that the boot installation length (L) is the length indicated below. Insert a suitable tool into the large end of the boot, as shown. Bleed air from the boot to prevent boot deformation.

Boot installation length (L) : Refer to [FAX-15, "Drive Shaft"](#).

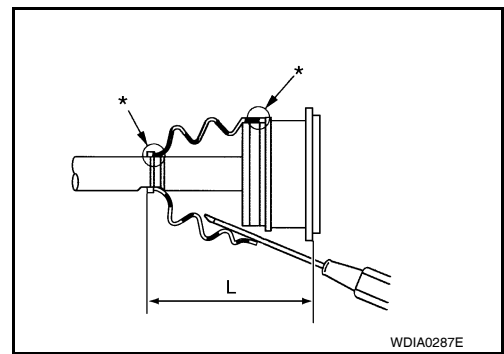

CAUTION:

- The boot may break if the boot installation length is less than the specified value.
- Do not contact inside surface of boot with tip of the suitable tool.

9. Secure the large and small ends of the boot with the new boot bands as shown.

NOTE:

Discard the old boot bands and use new ones for assembly.

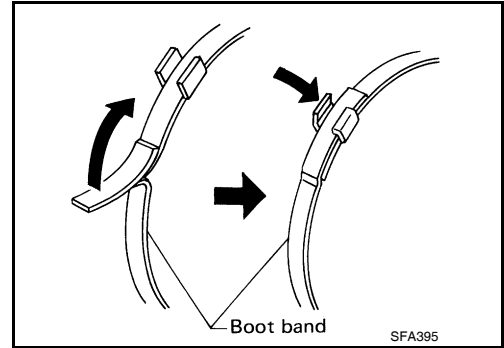

10. After installing the sliding joint housing to the drive shaft, rotate the boot to check that the boot is positioned correctly. If the boot is not positioned correctly, reposition the boot and secure the boot using a new boot band.

Wheel Side

1. Insert the Genuine NISSAN Grease or equivalent, into the joint sub-assembly serration hole until the grease begins to ooze from the ball groove and serration hole. Refer to [MA-21, "FOR NORTH AMERICA : Fluids and Lubricants"](#) (United States and Canada), [MA-22, "FOR MEXICO : Fluids and Lubricants"](#) (Mexico). After inserting the grease, use a shop cloth to wipe off the grease that has oozed out.

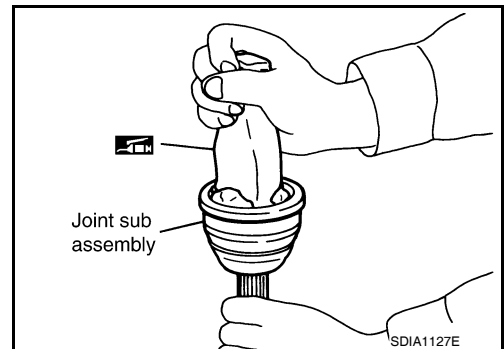

2. Wrap the serrated part of the drive shaft with tape. Install the boot band and boot onto the shaft. Do not damage the boot.

NOTE:

Discard the old boot band and boot and use a new one for assembly.

3. Remove the protective tape wound around the serrated part of the drive shaft.

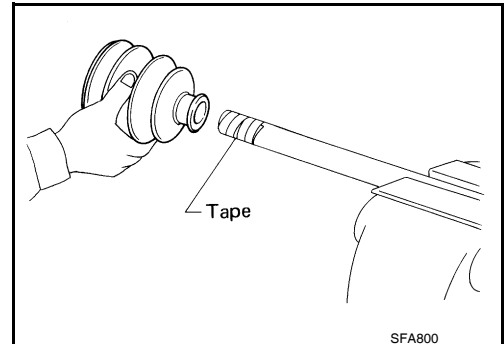

A
B
C
FAX
E
F
G
H
I
J
K
L
M
N
O
P

DRIVE SHAFT

< UNIT DISASSEMBLY AND ASSEMBLY >

- Attach the circlip to the drive shaft making sure circlip fits securely into groove on drive shaft. Then install drive shaft nut to end of joint sub-assembly, and press-fit the circlip using a suitable tool as shown.

NOTE:

Discard the old circlip and use a new one for assembly.

- Insert the specified quantity of Genuine NISSAN Grease or equivalent, into the joint sub-assembly and the large end of the boot. Refer to [MA-21, "FOR NORTH AMERICA : Fluids and Lubricants"](#) (United States and Canada), [MA-22, "FOR MEXICO : Fluids and Lubricants"](#) (Mexico).

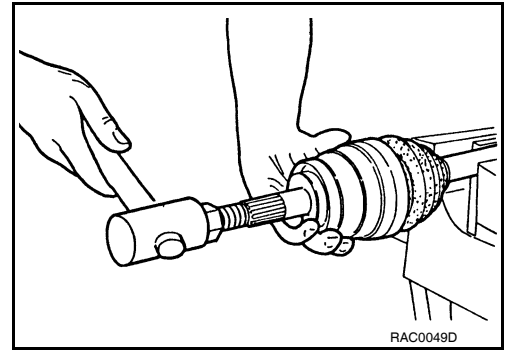

Grease capacity : Refer to [FAX-15, "Drive Shaft"](#).

- Install the boot securely into the grooves (indicated by the * marks) as shown.

CAUTION:

If there is grease on the boot mounting surfaces (indicated by the * marks) of the drive shaft and joint sub-assembly, the boot may come off. Remove all grease from the drive shaft surfaces.

- Check that the boot installation length (L) is the specified length. Insert a suitable tool into the large end of the boot, as shown. Bleed the air from the boot to prevent boot deformation.

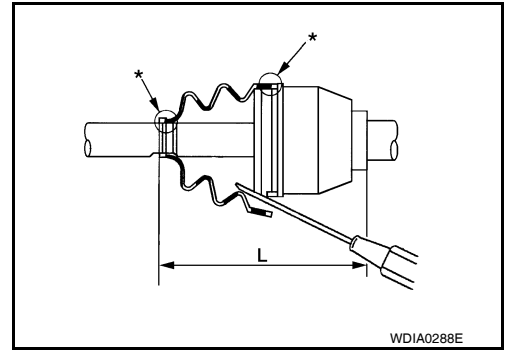

Boot installation length (L) : Refer to [FAX-15, "Drive Shaft"](#).

CAUTION:

- The boot may break if the boot installation length is less than the specified length.
- Do not contact inside surface of boot with the tip of the suitable tool.

- Secure large and small ends of the boot using new boot bands using tool as shown.

Tool number : KV40107300 (—)

NOTE:

Discard the old boot bands and use new ones for assembly.

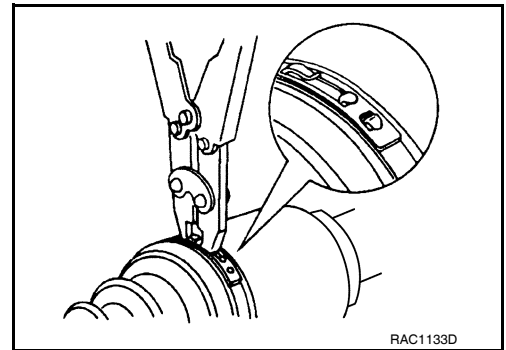

- Secure boot band so that dimension (M) meets specification as shown.

Dimension (M) : Refer to [FAX-15, "Boot Bands"](#).

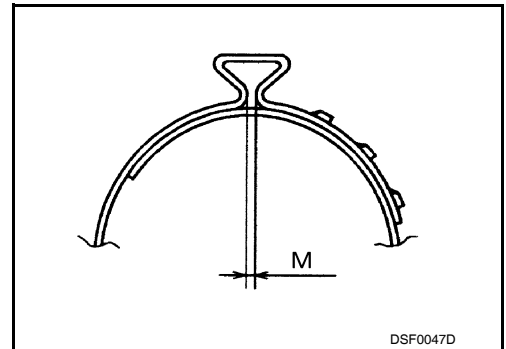

- After installing the housing to the shaft, rotate the boot to check that it is positioned correctly. If the boot is not positioned correctly, remove the old boot bands then reposition the boot and secure the boot with new boot bands.

SERVICE DATA AND SPECIFICATIONS (SDS)

< SERVICE DATA AND SPECIFICATIONS (SDS)

SERVICE DATA AND SPECIFICATIONS (SDS)

SERVICE DATA AND SPECIFICATIONS (SDS)

Wheel Bearing

INFOID:000000006161627

Axial end play	0.05 mm (0.002 in) or less
----------------	----------------------------

Drive Shaft

INFOID:000000006161628

FAX

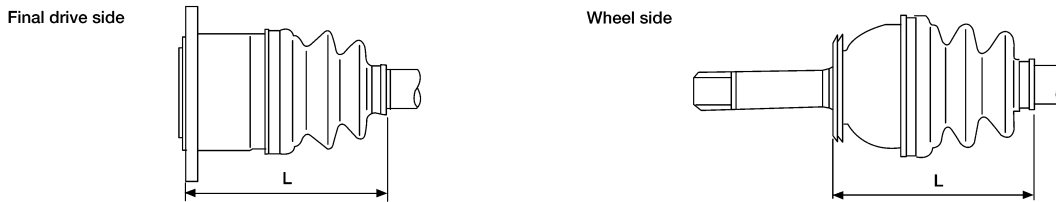

WDIA0055E

Drive shaft joint type	Final drive side	Rzeppa	
	Wheel side	Rzeppa	
Grease	Quality	Nissan Genuine Grease or equivalent	
	Capacity	Final drive side	130 - 150 g (4.58 - 5.29 oz)
		Wheel side	145 - 165 g (5.11 - 5.82 oz)
Boot length	Final drive side (L)	145 mm (5.71 in)	
	Wheel side (L)	168.4 mm (6.63 in)	

Boot Bands

INFOID:000000006161629

Unit: mm (in)

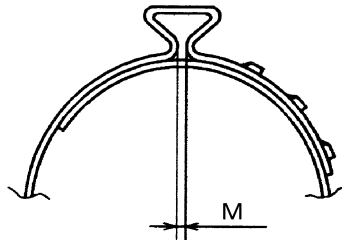

DSF0047D

Dimension (M)	1.0 - 4.0 (0.039 - 0.157)
---------------	---------------------------