

SECTION **RSU**
 REAR SUSPENSION

A
 B
 C
 D

RSU

CONTENTS

PRECAUTION	2	On-Vehicle Inspection and Service	5	F
PRECAUTIONS	2	REMOVAL AND INSTALLATION	6	
Precaution for Supplemental Restraint System (SRS) "AIR BAG" and "SEAT BELT PRE-TENSIONER"	2	REAR SUSPENSION ASSEMBLY	6	G
General Precautions	2	Component	6	
PREPARATION	3	LEAF SPRING	8	H
PREPARATION	3	Removal and Installation	8	
Commercial Service Tool	3	SHOCK ABSORBER	11	I
SYMPTOM DIAGNOSIS	4	Removal and Installation	11	
NOISE VIBRATION AND HARSHNESS (NVH) TROUBLESHOOTING	4	Disposal	11	J
NVH Troubleshooting Chart	4	SERVICE DATA AND SPECIFICATIONS (SDS)	12	
PERIODIC MAINTENANCE	5	SERVICE DATA AND SPECIFICATIONS (SDS)	12	K
REAR SUSPENSION ASSEMBLY	5	General Specification (Rear)	12	L
		Wheelarch Height (Unladen*1)	12	

M
 N
 O
 P

PRECAUTIONS

< PRECAUTION >

PRECAUTION

PRECAUTIONS

Precaution for Supplemental Restraint System (SRS) "AIR BAG" and "SEAT BELT PRE-TENSIONER"

INFOID:000000006161774

The Supplemental Restraint System such as "AIR BAG" and "SEAT BELT PRE-TENSIONER", used along with a front seat belt, helps to reduce the risk or severity of injury to the driver and front passenger for certain types of collision. This system includes seat belt switch inputs and dual stage front air bag modules. The SRS system uses the seat belt switches to determine the front air bag deployment, and may only deploy one front air bag, depending on the severity of a collision and whether the front occupants are belted or unbelted. Information necessary to service the system safely is included in the SR and SB section of this Service Manual.

WARNING:

- To avoid rendering the SRS inoperative, which could increase the risk of personal injury or death in the event of a collision which would result in air bag inflation, all maintenance must be performed by an authorized NISSAN/INFINITI dealer.
- Improper maintenance, including incorrect removal and installation of the SRS, can lead to personal injury caused by unintentional activation of the system. For removal of Spiral Cable and Air Bag Module, see the SR section.
- Do not use electrical test equipment on any circuit related to the SRS unless instructed to in this Service Manual. SRS wiring harnesses can be identified by yellow and/or orange harnesses or harness connectors.

PRECAUTIONS WHEN USING POWER TOOLS (AIR OR ELECTRIC) AND HAMMERS

WARNING:

- When working near the Airbag Diagnosis Sensor Unit or other Airbag System sensors with the Ignition ON or engine running, DO NOT use air or electric power tools or strike near the sensor(s) with a hammer. Heavy vibration could activate the sensor(s) and deploy the air bag(s), possibly causing serious injury.
- When using air or electric power tools or hammers, always switch the Ignition OFF, disconnect the battery, and wait at least 3 minutes before performing any service.

General Precautions

INFOID:000000006161775

- When installing rubber parts, final tightening must be carried out under unladen condition* with tires on ground.
* Fuel, radiator coolant, and engine oil are full. Spare tire, jack, hand tools, and mats are in their designated positions.

PREPARATION

< PREPARATION >

PREPARATION

PREPARATION

Commercial Service Tool

INFOID:000000006161776

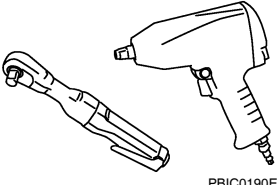
Tool name	Description
<p data-bbox="162 415 272 441">Power tool</p>  <p data-bbox="828 630 901 646">PBIC0190E</p>	<p data-bbox="1015 415 1258 441">Removing nuts and bolts</p>

A

B

C

D

RSU

F

G

H

I

J

K

L

M

N

O

P

NOISE VIBRATION AND HARSHNESS (NVH) TROUBLESHOOTING

< SYMPTOM DIAGNOSIS >

SYMPTOM DIAGNOSIS

NOISE VIBRATION AND HARSHNESS (NVH) TROUBLESHOOTING

NVH Troubleshooting Chart

INFOID:000000006161777

Use the chart below to help you find the cause of the symptom. If necessary, repair or replace the parts.

Reference page		RSU-6	RSU-11	RSU-6	RSU-6	RSU-8	RSU-6	DLN-139. "NVH Troubleshooting Chart" (2S1410), DLN-148. "NVH Troubleshooting Chart" (3S1410)	DLN-192. "NVH Troubleshooting Chart"	RAX-4. "NVH Troubleshooting Chart"	FSU-5. "NVH Troubleshooting Chart"	FSU-5. "NVH Troubleshooting Chart"	BR-5. "NVH Troubleshooting Chart"	ST-5. "NVH Troubleshooting Chart"
Possible cause and SUSPECTED PARTS		Improper installation, looseness	Shock absorber deformation, damage or deflection	Bushing or mounting deterioration	Parts interference	Spring fatigue	Suspension looseness	PROPELLER SHAFT	REAR FINAL DRIVE	AXLE	TIRES	ROAD WHEEL	BRAKES	STEERING
Symptoms	Noise	x	x	x	x	x	x	x	x	x	x	x	x	x
	Shake	x	x	x	x		x	x		x	x	x	x	x
	Vibration	x	x	x	x	x		x		x	x			x
	Shimmy	x	x	x	x					x	x	x	x	x
	Shudder	x	x	x						x	x	x	x	x
	Poor quality ride or handling	x	x	x	x	x	x			x	x	x		

x: Applicable

REAR SUSPENSION ASSEMBLY

< PERIODIC MAINTENANCE >

PERIODIC MAINTENANCE

REAR SUSPENSION ASSEMBLY

On-Vehicle Inspection and Service

INFOID:000000006161778

- Check the rear suspension parts for any excessive play, cracks, wear, and other damage.
- Shake each rear wheel to check for any excessive play as shown.
- Tighten all of the nuts and bolts to the specified torque. Refer to [RSU-6, "Component"](#).

CAUTION:

When installing the components with rubber bushings, the final tightening of the nuts and bolts must be done with the vehicle in an unladen condition (the fuel, engine coolant, and engine oil full; the spare tire, jack, hand tools and mats in their designated positions) with the tires on the ground.

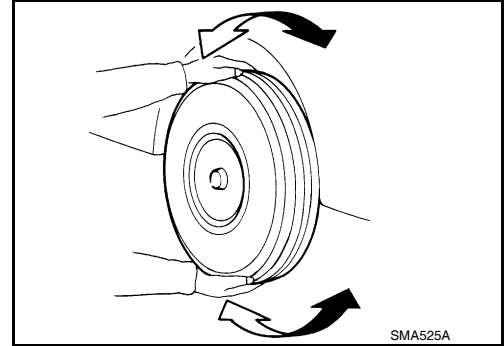

- Check the shock absorbers for oil leaks, deformation, and other damage.
- Check the shock absorber bushings for excessive wear and other damage.

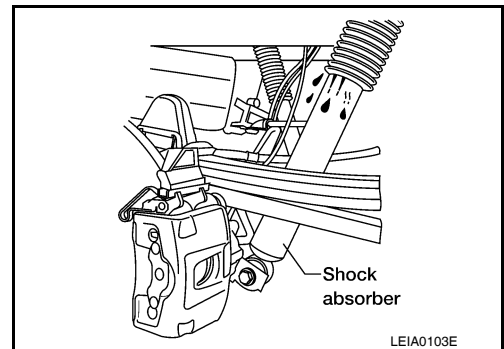

A
B
C
D
RSU
F
G
H
I
J
K
L
M
N
O
P

REAR SUSPENSION ASSEMBLY

< REMOVAL AND INSTALLATION >

REMOVAL AND INSTALLATION

REAR SUSPENSION ASSEMBLY

Component

INFOID:000000006161779

SEC. 431

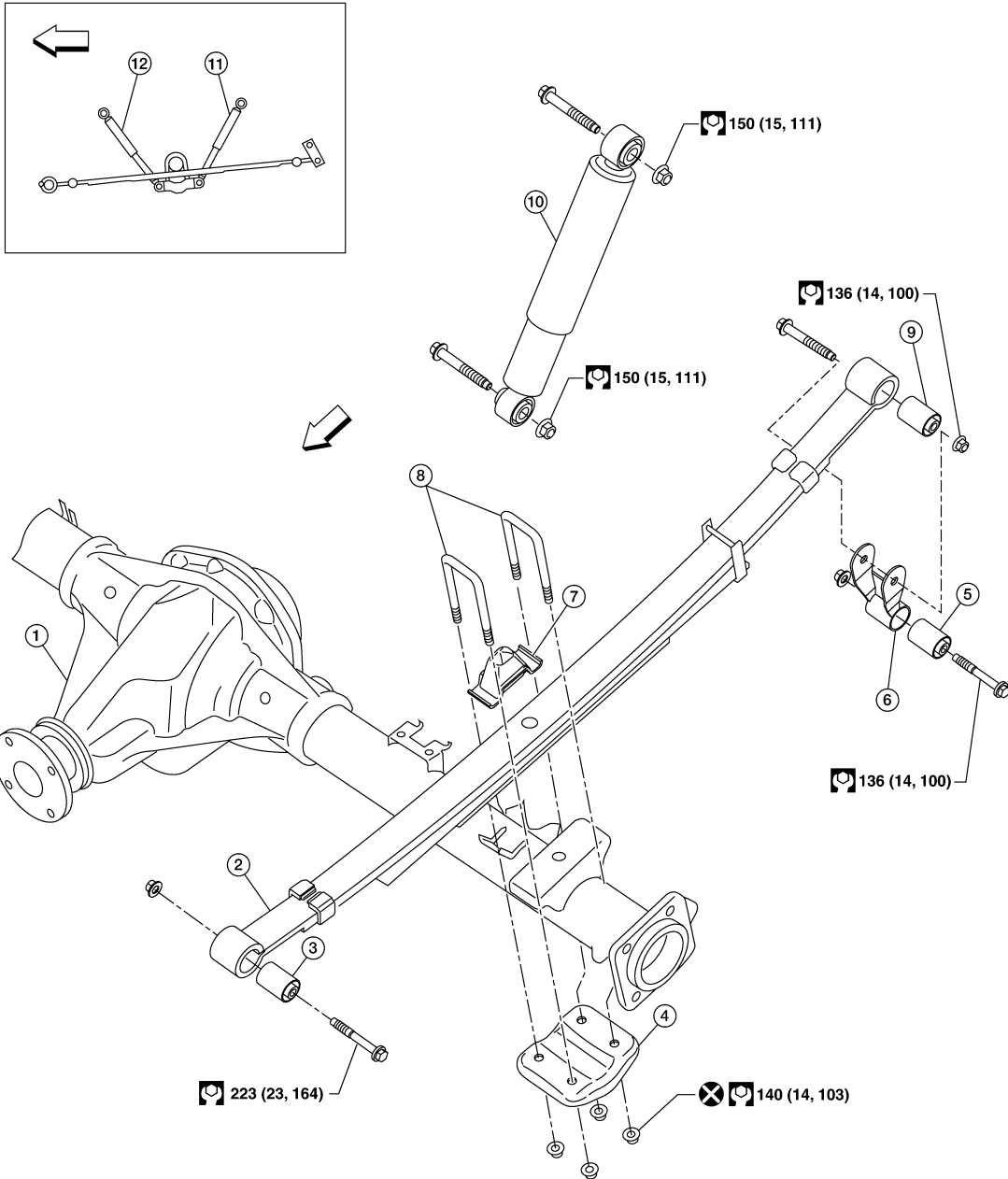

AWEIA0071GB

- | | | |
|---------------------|--------------------------------|---------------------------------|
| 1. Rear final drive | 2. Rear leaf spring | 3. Rear spring bushing (front) |
| 4. Rear spring pad | 5. Rear spring shackle bushing | 6. Rear spring shackle |
| 7. Bumper | 8. Rear spring clip U-bolts | 9. Rear spring bushing (rear) |
| 10. Shock absorber | 11. Shock absorber (left side) | 12. Shock absorber (right side) |
- ← Front

REAR SUSPENSION ASSEMBLY

< REMOVAL AND INSTALLATION >

CAUTION:

When installing the components with rubber bushings, the final tightening of the nuts and bolts must be done with the vehicle in an unladen condition (the fuel, engine coolant, and engine oil full; the spare tire, jack, hand tools and mats in their designated positions) with the tires on the ground.

A

B

C

D

RSU

F

G

H

I

J

K

L

M

N

O

P

LEAF SPRING

< REMOVAL AND INSTALLATION >

LEAF SPRING

Removal and Installation

INFOID:000000006161780

CAUTION:

When installing the components with rubber bushings, the final nut tightening must be carried out under unladen* conditions with the tires on level ground.

* (Fuel, radiator coolant and engine oil full. Spare tire, jack, hand tools and mats in designated positions.)

REMOVAL

1. Remove wheel and tire.
2. Support the rear final drive assembly with a suitable jack to relieve the tension from the leaf spring.
 - The axle weight should be supported, but there should be no compression in the spring.
3. Remove the shock absorber lower nut and bolt using power tool.

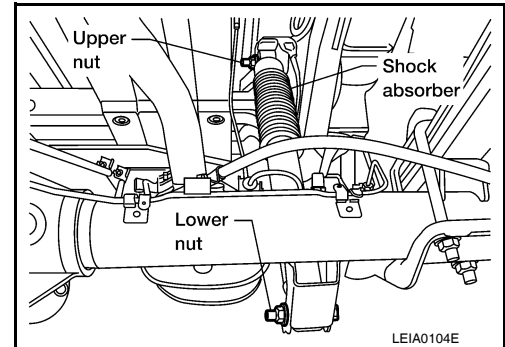

4. Remove the four rear spring clip U-bolt nuts using power tool, then remove the rear spring pad.

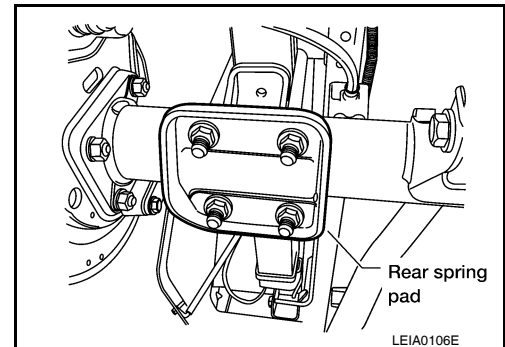

5. Remove the rear spring shackle lower nut and bolt using power tool.
 - If removing the LH rear leaf spring, remove the storage box if equipped, to access the rear spring shackle lower nut and bolt. Refer to [EXT-34. "Removal and Installation"](#).

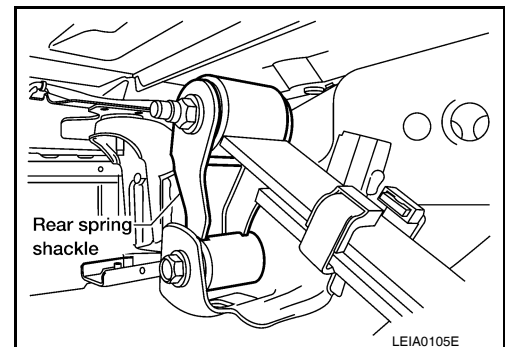

LEAF SPRING

< REMOVAL AND INSTALLATION >

6. Remove the rear leaf spring front nut and bolt using power tool.
7. Remove the rear leaf spring.
8. Remove the rear spring shackle from the rear leaf spring as necessary, using power tool.

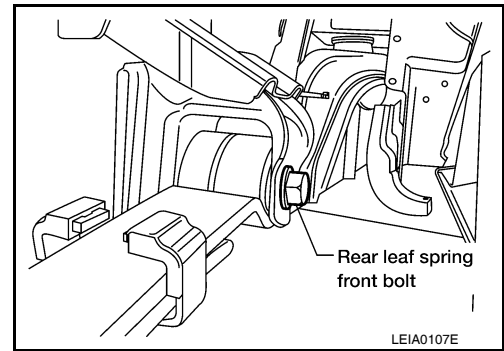

INSPECTION AFTER REMOVAL

- Check the rear leaf spring for any cracks or damage. Replace the rear leaf spring if necessary.
- Check the rear spring shackle, rear spring clip U-bolts, bumper, and rear spring pad for excessive wear, cracks, straightness, and damage. Replace any components if necessary.
- Check all bushings for deformation and cracks. Replace any bushings if necessary.

INSTALLATION

1. Apply soapsuds to all of the rubber bushings.
2. Install the rear spring shackle and rear leaf spring front nut and bolt. Finger-tighten the nuts.
3. Install the rear spring clip U-bolts and bumper on top of the rear leaf spring.
4. Install the rear spring pad, and new rear spring clip U-bolt nuts under the rear final drive axle case.

CAUTION:

Use new rear spring clip U-bolt nuts for installation.

5. Tighten the rear spring clip U-bolt nuts diagonally and evenly using the following sequence:
 - a. Tighten the rear spring clip U-bolt nuts until the rear spring pad contacts the rear final drive axle case.
 - b. Tighten the rear spring clip U-bolt nuts diagonally and evenly to 50 N·m (5.1 kg-m, 37 ft-lb).
 - c. Tighten the rear spring clip U-bolt nuts to specification so the lengths of all the exposed rear spring clip U-bolt threads under the rear spring pad are equal in length as shown.

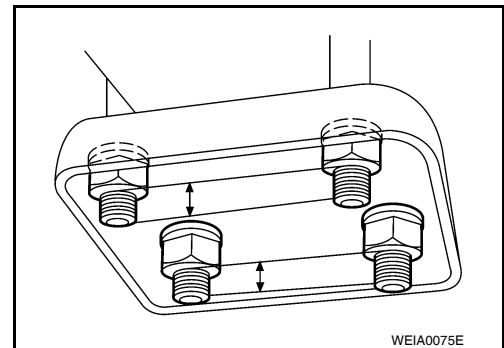

6. Install the shock absorber, and finger-tighten the nuts.
7. Remove the jack supporting the rear final drive assembly and bounce the rear of the vehicle to stabilize the suspension. (unladen)

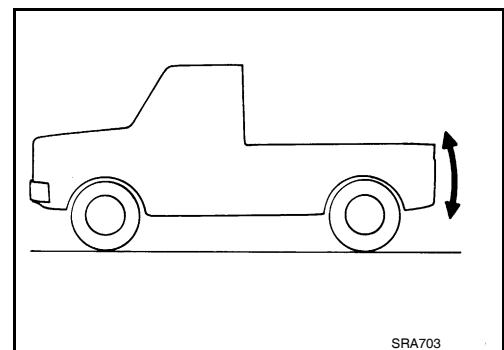

8. Tighten the rear spring shackle nuts, rear leaf spring front nut and shock absorber nuts to specification. Refer to [RSU-6. "Component"](#).

CAUTION:

When installing the components with rubber bushings, the final nut tightening must be carried out under unladen* conditions with the tires on level ground.

*** (Fuel, radiator coolant and engine oil full. Spare tire, jack, hand tools and mats in designated positions.)**

9. Install storage box, if equipped. Refer to [EXT-34. "Removal and Installation"](#).

LEAF SPRING

< REMOVAL AND INSTALLATION >

10. Install wheel and tire tightening wheel nuts to specification. Refer to [WT-46. "Adjustment"](#).

SHOCK ABSORBER

< REMOVAL AND INSTALLATION >

SHOCK ABSORBER

Removal and Installation

INFOID:000000006161781

REMOVAL

1. Support the rear final drive and suspension assembly using a suitable jack.
2. Remove the shock absorber upper and lower nuts and bolts using power tool.
3. Remove the shock absorber.

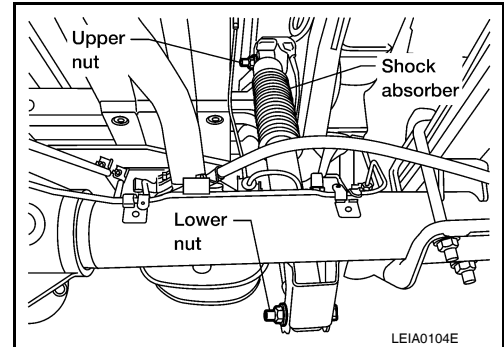

INSPECTION AFTER REMOVAL

Inspect the shock absorber for any oil leaks, cracks, or deformations. Replace the shock absorber as necessary.

INSTALLATION

Installation is in the reverse order of removal.

Shock absorber upper and lower nuts : Refer to [RSU-6, "Component"](#).

Disposal

INFOID:000000006161782

1. Set shock absorber horizontally with the piston rod fully extended.
2. Drill 2 – 3 mm (0.08 – 0.12 in) hole at the position (●) from top as shown in the figure to release gas gradually.

CAUTION:

- Wear eye protection (safety glasses).
- Wear gloves.
- Be careful with metal chips or oil blown out by the compressed gas.

NOTE:

- Drill vertically in this direction (←).
- Directly to the outer tube avoiding brackets.
- The gas is clear, colorless, odorless, and harmless.

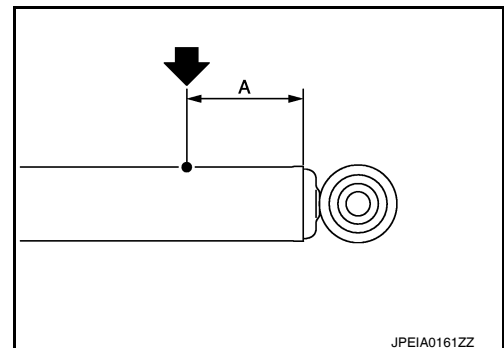

A : 20 – 30 mm (0.79 – 1.18 in)

3. Position the drilled hole downward and drain oil by moving the piston rod several times.

CAUTION:

Dispose of drained oil according to the law and local regulations.

SERVICE DATA AND SPECIFICATIONS (SDS)

< SERVICE DATA AND SPECIFICATIONS (SDS)

SERVICE DATA AND SPECIFICATIONS (SDS)

SERVICE DATA AND SPECIFICATIONS (SDS)

General Specification (Rear)

INFOID:000000006161784

Suspension type	Rigid axle with semi-elliptic leaf spring
Shock absorber type	Double-acting hydraulic

Wheelarch Height (Unladen*1)

INFOID:000000006161784

Unit: mm (in)

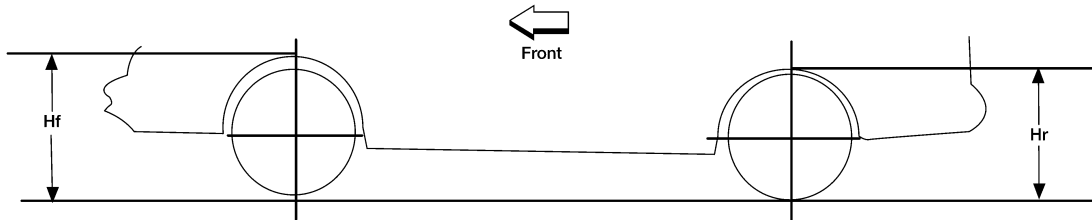

LEIA0085E

Drive type	2WD				4WD*2				4WD*3				
	Short		Long		Short		Long		Short		Long		
Wheel base	King Cab		Crew Cab		King Cab		Crew Cab		King Cab		Crew Cab		
Body	King Cab	Crew Cab	King Cab	Crew Cab	King Cab	Crew Cab	King Cab	Crew Cab	King Cab	Crew Cab	King Cab	Crew Cab	
Front wheel arch height (Hf)	P265/70R18	912 (35.91)	914 (35.98)	912 (35.91)	914 (35.98)	949 (37.36)	951 (37.44)	949 (37.36)	951 (37.44)	949 (37.36)	951 (37.44)	949 (37.36)	951 (37.44)
	P275/70R18	922 (36.30)	925 (36.42)	922 (36.30)	925 (36.42)	960 (37.80)	962 (37.87)	959 (37.76)	962 (37.87)	960 (37.80)	962 (37.87)	959 (37.76)	962 (37.87)
	P275/60R20	917 (36.10)	919 (36.18)	917 (36.10)	920 (36.22)	955 (37.60)	957 (37.68)	954 (37.56)	957 (37.68)	955 (37.60)	957 (37.68)	954 (37.56)	957 (37.68)
Rear wheel arch height (Hr)	P265/70R18	952 (37.48)	954 (37.56)	950 (37.40)	951 (37.44)	991 (39.02)	994 (39.13)	989 (38.94)	991 (39.02)	991 (39.02)	993 (39.09)	989 (38.94)	991 (39.02)
	P275/70R18	962 (37.87)	965 (37.99)	960 (37.80)	962 (37.87)	1002 (39.45)	1004 (39.53)	1000 (39.37)	1002 (39.45)	1001 (39.41)	1004 (39.53)	1000 (39.37)	1002 (39.45)
	P275/60R20	957 (37.68)	959 (37.76)	955 (37.60)	956 (37.64)	996 (39.21)	999 (39.33)	995 (39.17)	996 (39.21)	996 (39.21)	998 (39.29)	995 (39.17)	996 (39.21)

*1: Fuel, radiator coolant and engine oil full. Spare tire, jack, hand tools and mats in designated positions.

*2: Without tow package.

*3: With tow package.