

SECTION **FSU**
FRONT SUSPENSION

A
B
C
D

FSU

CONTENTS

PRECAUTION	2	UNIT REMOVAL AND INSTALLATION	13	F
PRECAUTIONS	2	KNUCKLE	13	G
Precaution for Supplemental Restraint System (SRS) "AIR BAG" and "SEAT BELT PRE-TENSIONER"	2	Removal and Installation	13	
Precaution	2	UPPER BALL JOINT AND LOWER BALL JOINT	15	H
PREPARATION	3	Removal and Installation	15	
PREPARATION	3	LOWER LINK	16	I
Special Service Tool	3	Removal and Installation	16	
Commercial Service Tool	3	UPPER LINK	17	J
SYMPTOM DIAGNOSIS	4	Removal and Installation	17	
NOISE, VIBRATION, AND HARSHNESS (NVH) TROUBLESHOOTING	4	STABILIZER BAR	18	K
NVH Troubleshooting Chart	4	Removal and Installation	18	
PERIODIC MAINTENANCE	5	COIL SPRING AND SHOCK ABSORBER	19	L
ON-VEHICLE SERVICE	5	Removal and Installation	19	
Front Suspension Parts	5	Disposal	19	
Front Wheel Alignment	5	UNIT DISASSEMBLY AND ASSEMBLY ...	20	M
UPPER BALL JOINT AND LOWER BALL JOINT	9	COIL SPRING AND SHOCK ABSORBER	20	
Inspection	9	Disassembly and Assembly	20	
KNUCKLE	11	SERVICE DATA AND SPECIFICATIONS (SDS)	22	N
On-Vehicle Inspection and Service	11	SERVICE DATA AND SPECIFICATIONS (SDS)	22	O
REMOVAL AND INSTALLATION	12	General Specification (Front)	22	
FRONT SUSPENSION ASSEMBLY	12	Spring Free Height	22	
Component	12	Wheel Alignment (Unladen*1)	22	
		Ball Joint	23	P
		Wheelarch Height (Unladen*1)	23	

PRECAUTIONS

< PRECAUTION >

PRECAUTION

PRECAUTIONS

Precaution for Supplemental Restraint System (SRS) "AIR BAG" and "SEAT BELT PRE-TENSIONER"

INFOID:000000007306920

The Supplemental Restraint System such as "AIR BAG" and "SEAT BELT PRE-TENSIONER", used along with a front seat belt, helps to reduce the risk or severity of injury to the driver and front passenger for certain types of collision. This system includes seat belt switch inputs and dual stage front air bag modules. The SRS system uses the seat belt switches to determine the front air bag deployment, and may only deploy one front air bag, depending on the severity of a collision and whether the front occupants are belted or unbelted. Information necessary to service the system safely is included in the SR and SB section of this Service Manual.

WARNING:

- To avoid rendering the SRS inoperative, which could increase the risk of personal injury or death in the event of a collision which would result in air bag inflation, all maintenance must be performed by an authorized NISSAN/INFINITI dealer.
- Improper maintenance, including incorrect removal and installation of the SRS, can lead to personal injury caused by unintentional activation of the system. For removal of Spiral Cable and Air Bag Module, see the SR section.
- Do not use electrical test equipment on any circuit related to the SRS unless instructed to in this Service Manual. SRS wiring harnesses can be identified by yellow and/or orange harnesses or harness connectors.

PRECAUTIONS WHEN USING POWER TOOLS (AIR OR ELECTRIC) AND HAMMERS

WARNING:

- When working near the Airbag Diagnosis Sensor Unit or other Airbag System sensors with the Ignition ON or engine running, DO NOT use air or electric power tools or strike near the sensor(s) with a hammer. Heavy vibration could activate the sensor(s) and deploy the air bag(s), possibly causing serious injury.
- When using air or electric power tools or hammers, always switch the Ignition OFF, disconnect the battery, and wait at least 3 minutes before performing any service.

Precaution

INFOID:000000007306921

- When installing the rubber bushings, the final tightening must be done under unladen condition and with the tires on level ground. Oil will shorten the life of the rubber bushings, so wipe off any spilled oil immediately.
- Unladen condition means the fuel tank, engine coolant and lubricants are at the full specification. The spare tire, jack, hand tools, and mats are in their designated positions.
- After installing suspension components, check the wheel alignment.
- Lock nuts are not reusable. Always use new lock nuts for installation. New lock nuts are pre-oiled, do not apply any additional lubrication.

PREPARATION

< PREPARATION >

PREPARATION

PREPARATION

Special Service Tool

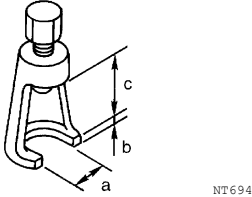
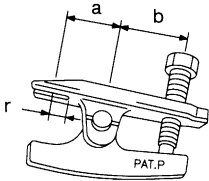
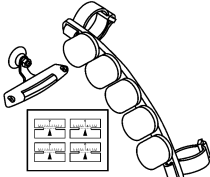

INFOID:000000007306922

The actual shapes of Kent-Moore tools may differ from those of special service tools illustrated here.

Tool number (Kent-Moore No.) Tool name	Description
ST29020001 (J-24319-01) Gear arm puller 	Removing ball joint for steering knuckle a: 34 mm (1.34 in) b: 6.5 mm (0.256 in) c: 61.5 mm (2.421 in)
HT72520000 (J-25730-A) Ball joint remover 	Removing tie-rod outer end a: 33 mm (1.30 in) b: 50 mm (1.97 in) r: 11.5 mm (0.453 in)
— (J-49286-1) Drift and pull gauge 	Measuring drift and pull

Commercial Service Tool

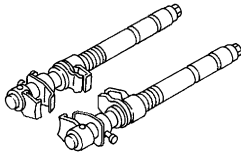
INFOID:000000007306923

Tool name	Description
Spring compressor 	Removing and installing coil spring
Power tool 	Loosening nuts, screws and bolts

NOISE, VIBRATION, AND HARSHNESS (NVH) TROUBLESHOOTING

< SYMPTOM DIAGNOSIS >

SYMPTOM DIAGNOSIS

NOISE, VIBRATION, AND HARSHNESS (NVH) TROUBLESHOOTING

NVH Troubleshooting Chart

INFOID:000000007306924

Use the chart below to help you find the cause of the symptom. Repair or replace parts as necessary.

Symptom		Possible Cause and SUSPECTED PARTS														Reference page		
		Improper installation, looseness	Shock absorber deformation,	Bushing or mounting deterioration	Parts interference	Spring fatigue	Suspension looseness	Incorrect wheel alignment	Stabilizer bar fatigue	PROPELLER SHAFT	FRONT FINAL DRIVE	DRIVE SHAFT	WHEEL HUB	TIRES	ROAD WHEEL		BRAKES	STEERING
Noise	Noise	x	x	x	x	x	x			x	x	x	x	x	x	x	x	FSU-12
	Shake	x	x	x	x		x			x		x	x	x	x	x	x	FSU-19
	Vibration	x	x	x	x	x				x		x	x	x				FSU-12
	Shimmy	x	x	x	x			x				x	x	x	x	x	x	FSU-12
	Shudder	x	x	x									x	x	x	x	x	FSU-20
	Poor quality ride or handling	x	x	x	x	x		x	x				x	x	x			FSU-12
																		FSU-5
																		FSU-18
																		DLN-130, "NVH Troubleshooting Chart" (2F1310)
																		DLN-163, "NVH Troubleshooting Chart"
																		FAX-4, "NVH Troubleshooting Chart"
																		FAX-4, "NVH Troubleshooting Chart"
																		WT-45, "NVH Troubleshooting Chart"
																		WT-45, "NVH Troubleshooting Chart"
																		BR-5, "NVH Troubleshooting Chart"
																		ST-5, "NVH Troubleshooting Chart"

x: Applicable

ON-VEHICLE SERVICE

< PERIODIC MAINTENANCE >

PERIODIC MAINTENANCE

ON-VEHICLE SERVICE

Front Suspension Parts

INFOID:000000007306925

Check front suspension parts for excessive play, cracks, wear and other damage.

- Shake each front wheel to check for excessive play.
If looseness is noted, inspect wheel bearing end play, then check ball joint end play. Refer to [FAX-5, "On-Vehicle Inspection and Service"](#) and [FSU-9, "Inspection"](#).
- Make sure that the cotter pin is inserted (4WD only).
- Retighten all nuts and bolts to the specified torque.

Suspension component torque : Refer to [FSU-12, "Component"](#) .

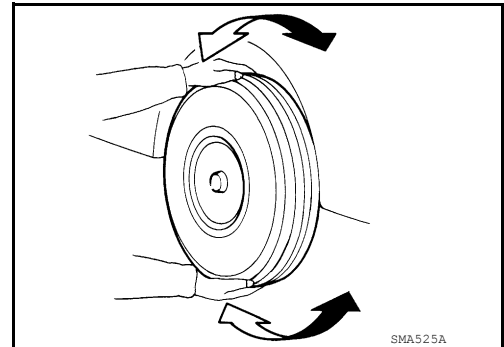

- Check shock absorber for oil leakage and other damage.
- Check suspension ball joint for grease leakage and ball joint dust cover for cracks and other damage.

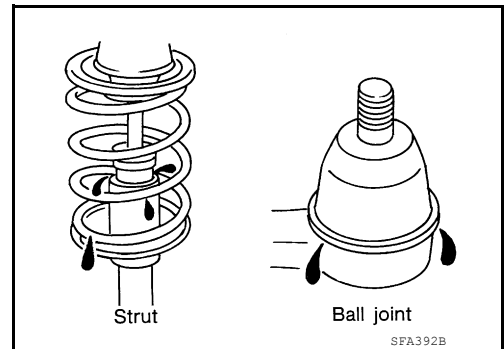

Front Wheel Alignment

INFOID:000000007306926

PRELIMINARY INSPECTION

WARNING:

Always adjust the alignment with the vehicle on a flat surface.

NOTE:

If alignment is out of specification, inspect and replace any damaged or worn suspension parts before making any adjustments.

1. Check and adjust the wheel alignment with the vehicle under unladen conditions. "Unladen conditions" means that the fuel, coolant, and lubricant are full; and that the spare tire, jack, hand tools and mats are in their designated positions.
2. Check the tires for incorrect air pressure and excessive wear.
3. Check the wheels for run out and damage. Refer to [WT-48, "Inspection"](#).
4. Check the wheel bearing axial end play. Refer to [FAX-5, "On-Vehicle Inspection and Service"](#) .
5. Check the shock absorbers for leaks or damage.
6. Check each mounting point of the suspension components for any excessive looseness or damage.
7. Check each link, arm, and the rear suspension member for any damage.
8. Check the vehicle height. Refer to [FSU-23, "Wheelarch Height \(Unladen*1\)"](#) .

GENERAL INFORMATION AND RECOMMENDATIONS

1. A Four-Wheel Thrust Alignment should be performed.
 - This type of alignment is recommended for any NISSAN vehicle.
 - The four-wheel "thrust" process helps ensure that the vehicle is properly aligned and the steering wheel is centered.
 - The alignment machine itself should be capable of accepting any NISSAN vehicle.
 - The alignment machine should be checked to ensure that it is level.
2. Make sure the alignment machine is properly calibrated.

ON-VEHICLE SERVICE

< PERIODIC MAINTENANCE >

- Your alignment machine should be regularly calibrated in order to give correct information.
- Check with the manufacturer of your specific alignment machine for their recommended Service/Calibration Schedule.

THE ALIGNMENT PROCESS

IMPORTANT: Use only the alignment specifications listed in this Service Manual. Refer to [FSU-22, "Wheel Alignment \(Unladen*1\)"](#).

1. When displaying the alignment settings, many alignment machines use "indicators": (Green/red, plus or minus, Go/No Go). **Do NOT use these indicators.**
 - The alignment specifications programmed into your alignment machine that operate these indicators may not be correct.
 - This may result in an ERROR.
2. Most camera-type alignment machines are equipped with both "Rolling Compensation" method and optional "Jacking Compensation" method to "compensate" the alignment targets or head units. "Rolling Compensation" is the preferred method.
 - If using the "Rolling Compensation" method, after installing the alignment targets or head units, push or pull on the rear wheel to move the vehicle. Do not push or pull on the vehicle body.
 - If using the "Jacking Compensation" method, after installing the alignment targets or head units, raise the vehicle and rotate the wheels 1/2 turn both ways.

NOTE:

- Do not use the "Rolling Compensation" method if you are using sensor-type alignment equipment.
- Follow all instructions in the alignment machine you are using for more information.

CAMBER AND CASTER

1. Measure camber and caster of both the right and left wheels and adjust as necessary to specification.

Camber and caster : Refer to [FSU-22, "Wheel Alignment \(Unladen*1\)"](#).

NOTE:

Some vehicles may be equipped with straight (non-adjustable) lower link bolts and washers. In order to adjust camber and caster on these vehicles, first replace the lower link bolts and washers with adjustable (cam) bolts and washers.

2. If outside of the specified value, adjust camber and caster using the cam bolts (1) in the front lower link (2).

CAUTION:

After adjusting the camber and caster check the toe-in.

NOTE:

Camber changes about 3' (0.05°) with each graduation of one cam bolt (1). Refer to table below for examples of lower link cam bolt (1) effect on camber and caster.

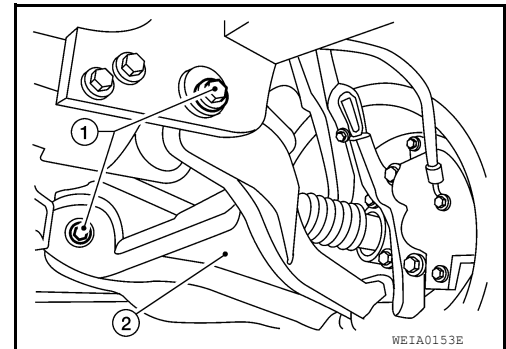

Rear cam bolt	1 In	1 Out	1 In	1 Out	0	0	1 In	1 Out
Front cam bolt	1 Out	1 In	1 In	1 Out	1 In	1 Out	0	0
Camber Degree minute (Decimal degree)	0 (0)	0 (0)	7' (0.12°)	- 7' (-0.12°)	3' (0.05°)	- 3' (-0.05°)	3' (0.05°)	- 3' (-0.05°)
Caster Degree minute (Decimal degree)	- 14' (-0.23°)	14' (0.23°)	0 (0)	0 (0)	7' (0.12°)	- 7' (-0.12°)	- 7' (-0.12°)	7' (0.12°)

3. Tighten the cam bolt nuts to specification. Refer to [FSU-12, "Component"](#).

TOE-IN

WARNING:

ON-VEHICLE SERVICE

< PERIODIC MAINTENANCE >

- Always perform the following procedure on a flat surface.
 - Make sure that no person is in front of the vehicle before pushing it.
1. Bounce the front of vehicle up and down to stabilize the vehicle height (posture).
 2. Push the vehicle straight ahead about 5 m (16 ft).
 3. Put a mark on base line of the tread (rear side) of both front tires at the same height as hub center as shown. These marks are measuring points.

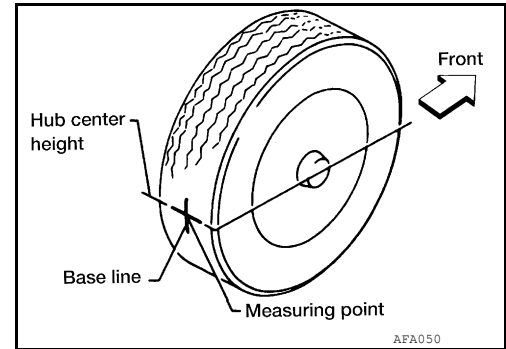

4. Measure the distance (A) on the rear side of the front tires as shown.
5. Push the vehicle slowly ahead to rotate the wheels 180° degrees (1/2 a turn).
CAUTION:
If the wheels have rotated more than 180° (1/2 turn), start this procedure again from the beginning. Never push the vehicle backward.
6. Measure the distance (B) on the front side of the front tires at the same marks as shown. Total toe-in is calculated as (A - B).

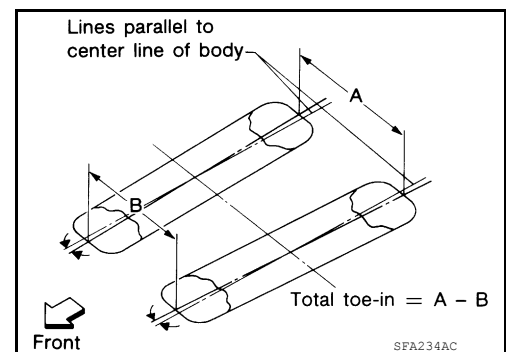

Total toe-in : Refer to [FSU-22, "Wheel Alignment \(Unladen*1\)"](#) .

7. Adjust the toe-in by varying the length of the steering outer socket.
 - a. Loosen the outer tie-rod lock nuts.
 - b. Adjust the toe-in by screwing the outer tie-rods in or out.

Standard length (L) : Refer to [ST-32, "Steering Outer Socket and Steering Inner Socket"](#) .

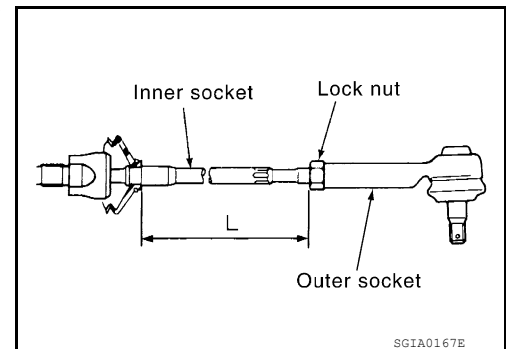

- c. Tighten the outer tie-rod lock nuts to specification.

Lock nut : Refer to [ST-27, "Disassembly and Assembly"](#) .

FRONT WHEEL TURNING ANGLE

NOTE:

Check front wheel turning angle after the toe-in inspection.

1. Place front wheels on turning radius gauges in straight ahead position and rear wheels on stands so that vehicle can be level. Check the maximum inner and outer wheel turning angles for LH and RH road wheels.
2. Start engine and run at idle, turn steering wheel all the way right and left, measure the turning angle.

Wheel turning angle (full turn) : Refer to [FSU-22, "Wheel Alignment \(Unladen*1\)"](#) .

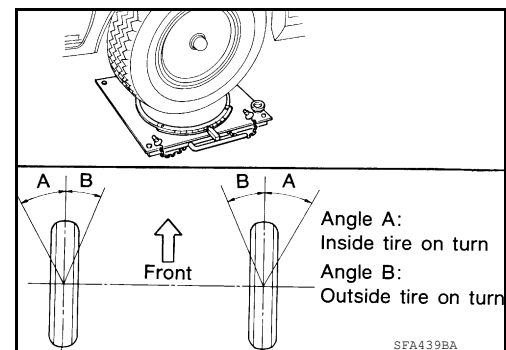

ON-VEHICLE SERVICE

< PERIODIC MAINTENANCE >

- Any turning angles are not adjustable. If any of steering angles are out of the specification, check if the following parts are worn or damaged.
 - Steering gear
 - Steering column
 - Front suspension components
- If found that they are worn or damaged, replace them with new ones.

UPPER BALL JOINT AND LOWER BALL JOINT

< PERIODIC MAINTENANCE >

UPPER BALL JOINT AND LOWER BALL JOINT

Inspection

INFOID:000000007306927

- Check the ball joint for excessive play. Replace the upper or lower link assembly if any of the following exists:
 - Ball joint stud is worn.
 - Ball joint is hard to swing.
 - Ball joint play in axial directions or end play is excessive.

Swinging Force

NOTE:

Before checking the axial forces and end play, turn the lower ball joint at least 10 revolutions so that the ball joint is properly broken in.

1. Measure the ball joint swinging force using a suitable tool.
 - Measure at the cotter pin hole for upper ball joint as shown.
 - Measure at the groove for lower ball joint as shown.

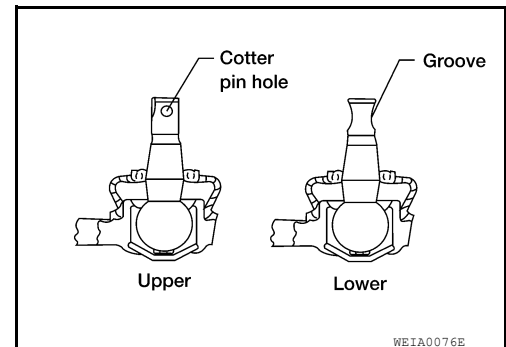

2. Verify the ball joint swinging force is within specification.

Swinging force (A)

Upper ball joint : Refer to [FSU-23, "Ball Joint"](#).

Lower ball joint : Refer to [FSU-23, "Ball Joint"](#).

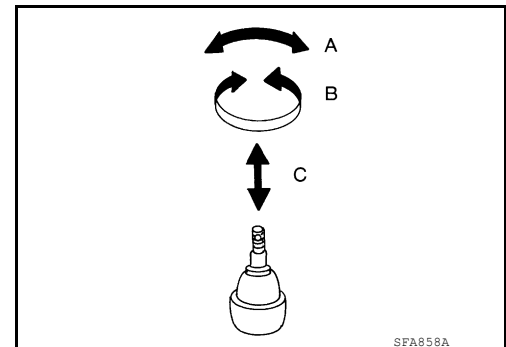

Turning Force

NOTE:

Before checking the axial forces and end play, turn the lower ball joint at least 10 revolutions so that the ball joint is properly broken in.

Turning torque (B) : Refer to [FSU-23, "Ball Joint"](#).

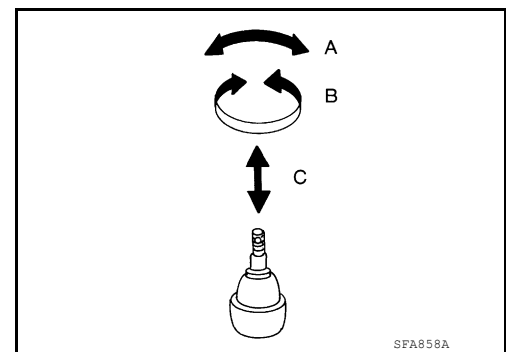

Vertical End Play

Check dust cover for damage. Replace it and the cover clamp if necessary.

NOTE:

UPPER BALL JOINT AND LOWER BALL JOINT

< PERIODIC MAINTENANCE >

Before checking the axial forces and end play, turn the lower ball joint at least 10 revolutions so that the ball joint is properly broken in.

Vertical end play (C) : Refer to [FSU-23, "Ball Joint"](#).

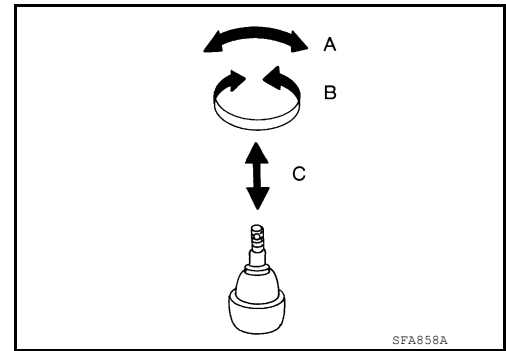

KNUCKLE

< PERIODIC MAINTENANCE >

KNUCKLE

On-Vehicle Inspection and Service

INFOID:000000007306928

Make sure the mounting conditions (looseness, backlash) of each component and component status (wear, damage) are within specifications. Refer to [FSU-23. "Ball Joint"](#).

A
B
C
D
F
G
H
I
J
K
L
M
N
O
P

FSU

FRONT SUSPENSION ASSEMBLY

< REMOVAL AND INSTALLATION >

REMOVAL AND INSTALLATION

FRONT SUSPENSION ASSEMBLY

Component

INFOID:000000007306929

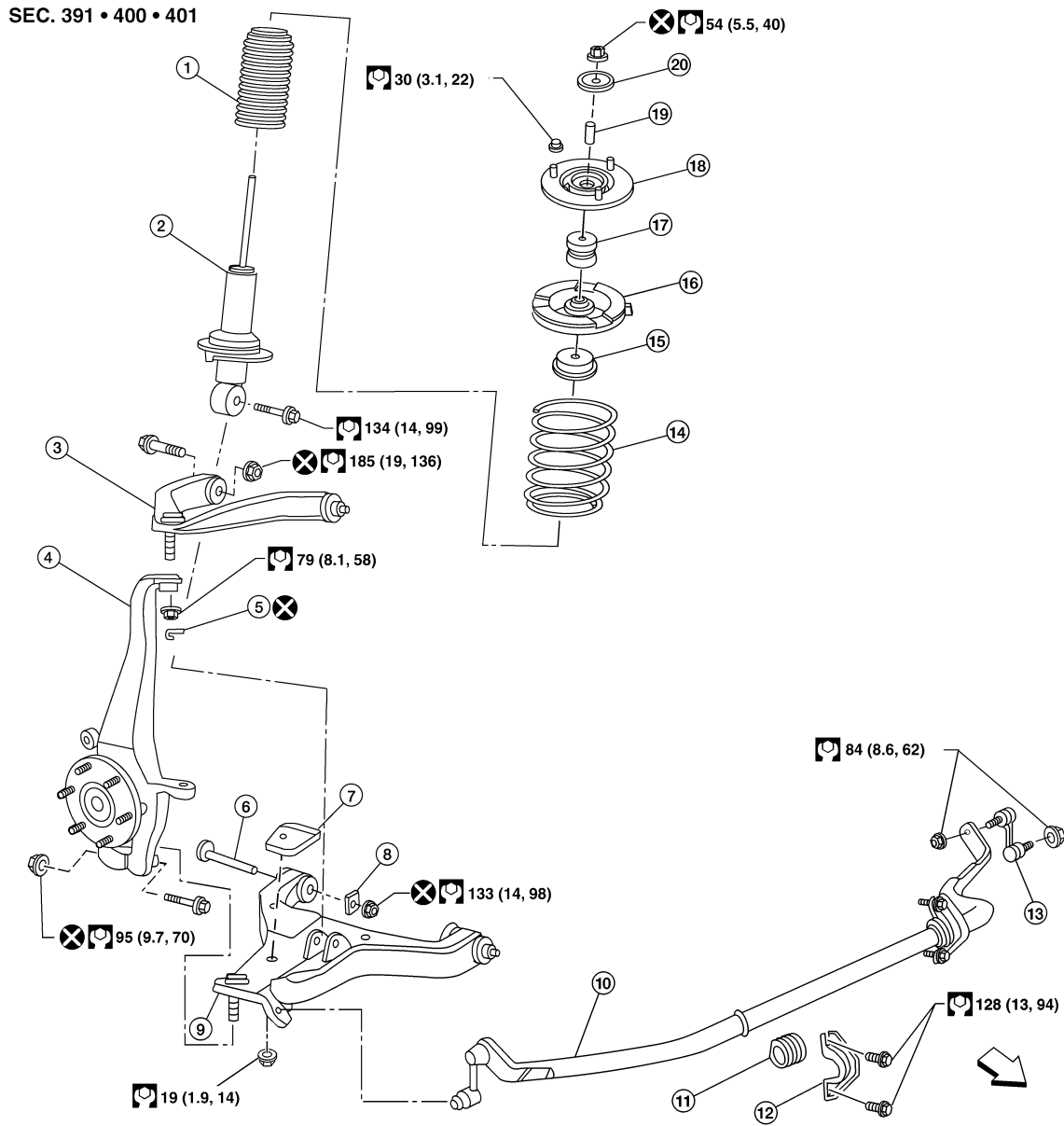

AWEIA0142GB

- | | | |
|-----------------------|----------------------------|---------------------------------------|
| 1. Dust cover | 2. Shock absorber | 3. Upper link |
| 4. Steering knuckle | 5. Cotter pin | 6. Bolt |
| 7. Jounce bumper | 8. Washer | 9. Lower link |
| 10. Stabilizer bar | 11. Stabilizer bar bushing | 12. Stabilizer bar mounting bracket |
| 13. Connecting rod | 14. Coil spring | 15. Upper seat |
| 16. Upper spring seat | 17. Shock absorber bushing | 18. Shock absorber mounting insulator |
| 19. Spacer | 20. Washer | ⇐ Front |

KNUCKLE

< UNIT REMOVAL AND INSTALLATION >

UNIT REMOVAL AND INSTALLATION

KNUCKLE

Removal and Installation

INFOID:000000007306930

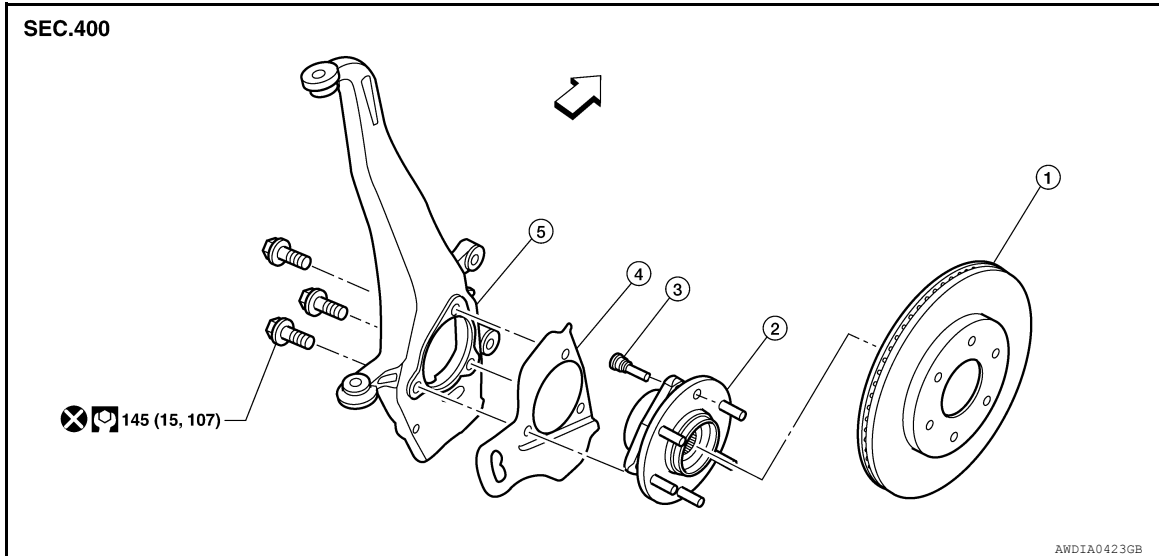

1. Disc rotor
 2. Wheel hub and bearing assembly
 3. Wheel stud
 4. Splash guard
 5. Steering knuckle
- ⇐ Front

REMOVAL

1. Remove wheel hub and bearing assembly. Refer to [FAX-6, "Removal and Installation"](#).
 - Disconnect wheel sensor harness connector. Do not remove wheel sensor from wheel hub and bearing assembly for this procedure.

2. Remove steering outer socket from steering knuckle using Tool.

CAUTION:

- Be careful not to damage ball joint boot.
- Temporarily tighten nut to prevent damage to threads and to prevent Tool from coming off.

Tool number : HT72520000 (J-25730-A)

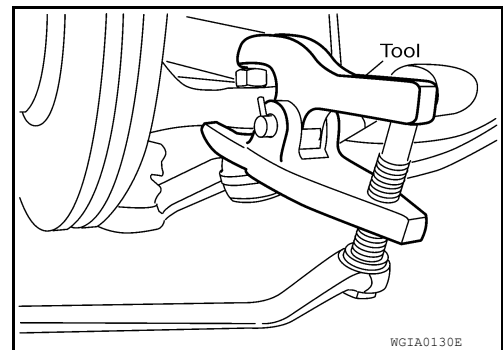

3. Remove cotter pin and nut from upper link ball joint and discard the cotter pin.
4. Separate upper link ball joint from steering knuckle using Tool.

Tool number : ST29020001 (J-24319-01)

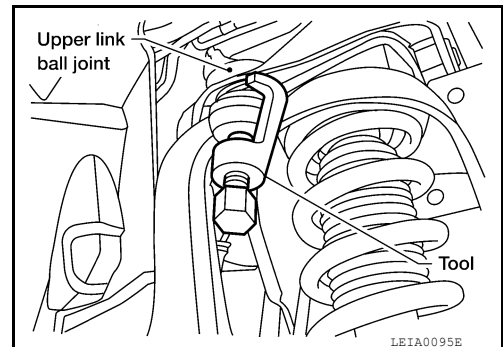

KNUCKLE

< UNIT REMOVAL AND INSTALLATION >

5. Remove the stabilizer bar connecting rod lower nut using a power tool, then separate the connecting rod from the lower link. Refer to [FSU-18, "Removal and Installation"](#).
6. Remove pinch bolt from steering knuckle using power tool, then separate lower link ball joint from steering knuckle.

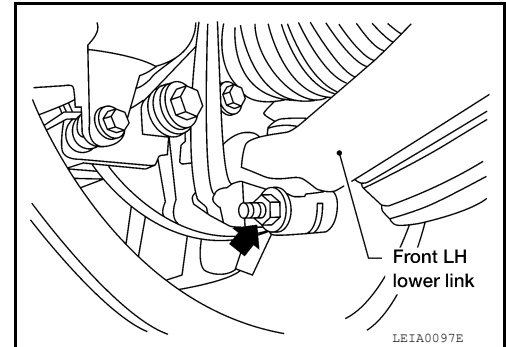

7. Remove steering knuckle from vehicle.

INSPECTION AFTER REMOVAL

Check for deformity, cracks and damage on each part, replace if necessary.

- Perform ball joint inspection. Refer to [FSU-9, "Inspection"](#).

INSTALLATION

Installation is in the reverse order of removal.

- Refer to [FSU-12, "Component"](#) for tightening torques.

CAUTION:

Use a new cotter pin for installation of lock nut.

- When installing disc rotor on wheel hub and bearing assembly, align the marks.

NOTE:

When not using the alignment mark, refer to [BR-49, "Front Disc Brake"](#).

- When installing wheel and tire, refer to [WT-49, "Adjustment"](#).

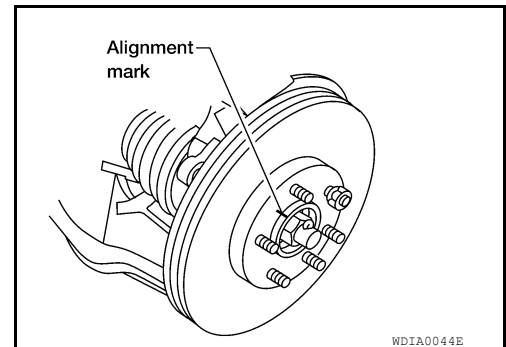

UPPER BALL JOINT AND LOWER BALL JOINT

< UNIT REMOVAL AND INSTALLATION >

UPPER BALL JOINT AND LOWER BALL JOINT

Removal and Installation

INFOID:000000007306931

The ball joints are part of the upper and lower links. Refer to [FSU-17. "Removal and Installation"](#) (upper link), [FSU-16. "Removal and Installation"](#) (lower link).

A
B
C
D
F
G
H
I
J
K
L
M
N
O
P

FSU

LOWER LINK

< UNIT REMOVAL AND INSTALLATION >

LOWER LINK

Removal and Installation

INFOID:000000007306932

REMOVAL

1. Remove the wheel and tire using power tool.
2. Remove lower shock absorber bolt.
3. Remove stabilizer bar connecting rod lower nut using power tool, then separate connecting rod from lower link. Refer to [FSU-18. "Removal and Installation"](#) .
4. Remove drive shaft, if equipped. Refer to [FAX-8. "Removal and Installation"](#) .
5. Remove pinch bolt from steering knuckle using power tool, then separate lower link ball joint from steering knuckle.

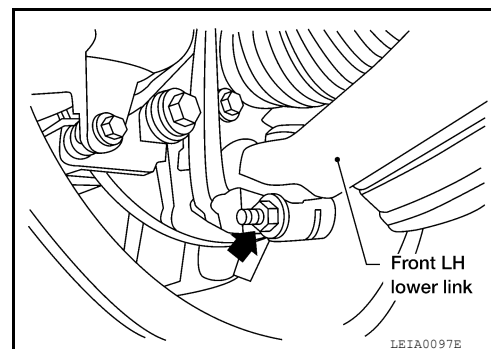

6. Remove lower link bolts (1) and nuts, then the lower link (2).

NOTE:

Some vehicles may be equipped with straight (non-adjustable) lower link bolts and washers. In order to adjust camber and caster on these vehicles, first replace the lower link bolts and washers with adjustable (cam) bolts and washers.

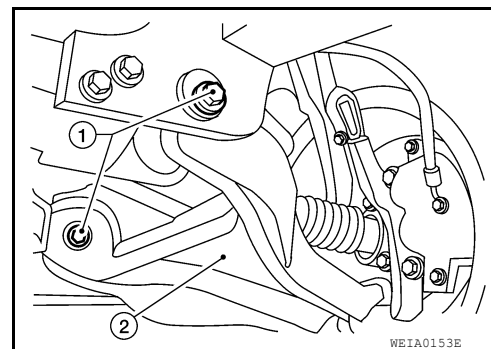

INSPECTION AFTER REMOVAL

Lower Link

Check for deformation and cracks. Replace if necessary.

Lower Link Bushing

Check for distortion and damage. Replace if necessary.

INSTALLATION

Installation is in the reverse order of removal.

- Tighten all nuts and bolts to specification. Refer to [FSU-12. "Component"](#) .
- When installing wheel and tire, refer to [WT-49. "Adjustment"](#).
- After installation, check that the front wheel alignment is within specification. Refer to [FSU-5. "Front Wheel Alignment"](#) .

UPPER LINK

< UNIT REMOVAL AND INSTALLATION >

UPPER LINK

Removal and Installation

INFOID:000000007306933

REMOVAL

1. Remove the wheel and tire using power tool.
2. Remove the fender protector to access upper link. Refer to [EXT-24, "Removal and Installation"](#).
3. Remove cotter pin and nut from upper link ball joint. Discard the cotter pin.
4. Separate upper link ball joint stud from steering knuckle using Tool.
 - Support lower link with jack.

Tool number : ST29020001 (J-24319-01)

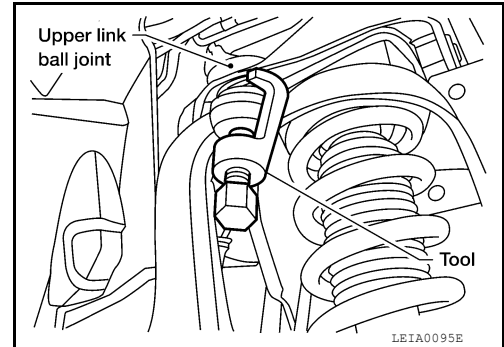

5. Remove upper link bolts and nuts, then remove the upper link.

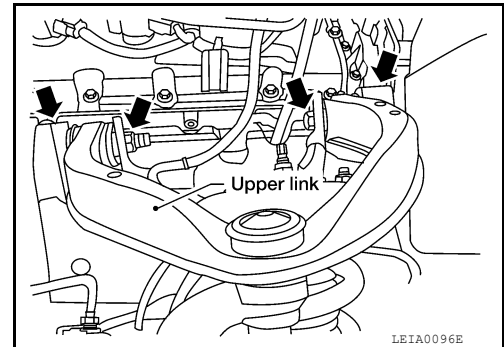

INSPECTION AFTER REMOVAL

Upper Link

Check for deformation and cracks. Replace if necessary.

Upper Link Ball Joint

Check for distortion and damage. Replace if necessary.

INSTALLATION

Installation is in the reverse order of removal.

- Tighten all nuts and bolts to specification. Refer to [FSU-12, "Component"](#).

CAUTION:

Use a new cotter pin for installation of upper link ball joint nut.

- When installing wheel and tire, refer to [WT-49, "Adjustment"](#).
- After installation, check that the front wheel alignment is within specification. Refer to [FSU-5, "Front Wheel Alignment"](#).

STABILIZER BAR

< UNIT REMOVAL AND INSTALLATION >

STABILIZER BAR

Removal and Installation

INFOID:000000007306934

REMOVAL

1. Remove engine under cover using power tool.
2. Remove stabilizer bar mounting bracket bolts and connecting rod nuts using power tool, as shown.
3. Remove bushings from stabilizer bar.

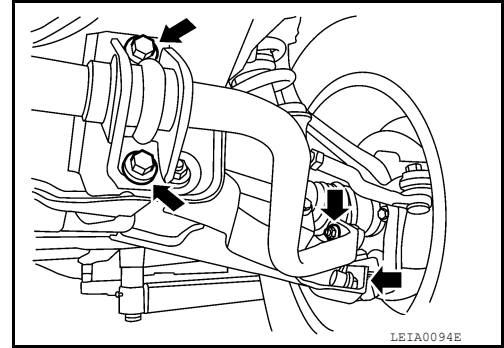

INSPECTION AFTER REMOVAL

- Check stabilizer bar for twist and deformation. Replace if necessary.
- Check rubber bushing for cracks, wear and deterioration. Replace if necessary.

INSTALLATION

Installation is in the reverse order of removal.

- Tighten all nuts and bolts to specification. Refer to [FSU-12, "Component"](#).

COIL SPRING AND SHOCK ABSORBER

< UNIT REMOVAL AND INSTALLATION >

COIL SPRING AND SHOCK ABSORBER

Removal and Installation

INFOID:000000007306935

REMOVAL

1. Remove the wheel and tire using power tool.
2. Remove the shock absorber lower bolt using power tool.
3. Remove the three shock absorber upper nuts using power tool.
4. Remove the coil spring and shock absorber assembly.
 - Turn steering knuckle out to gain enough clearance for removal.

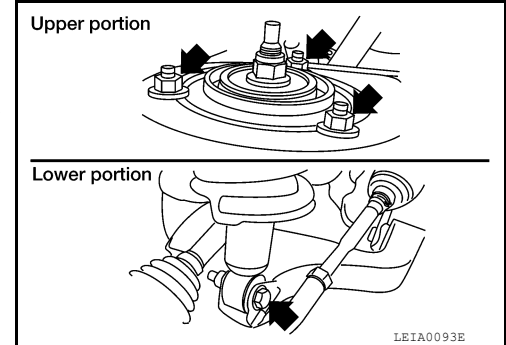

INSTALLATION

Installation is in the reverse order of removal.

- The lower seat step (2) in the shock absorber assembly (1) faces outside of vehicle.
- Upper spring insulator (3)
- ← : Front
- Tighten all nuts and bolts to specification. Refer to [FSU-12, "Component"](#).
- When installing wheel and tire, refer to [WT-49, "Adjustment"](#).

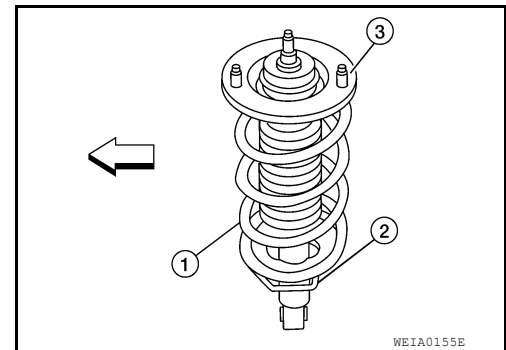

Disposal

INFOID:000000007306936

1. Set shock absorber horizontally with the piston rod fully extended.
2. Drill 2 – 3 mm (0.08 – 0.12 in) hole at the position (●) from top as shown in the figure to release gas gradually.

CAUTION:

- **Wear eye protection (safety glasses).**
- **Wear gloves.**
- **Be careful with metal chips or oil blown out by the compressed gas.**

NOTE:

- Drill vertically in this direction (←).
- Directly to the outer tube avoiding brackets.
- The gas is clear, colorless, odorless, and harmless.

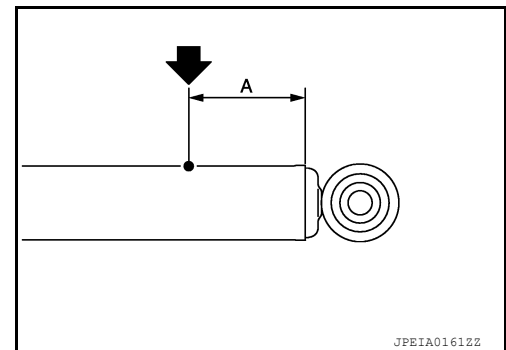

A : 20 – 30 mm (0.79 – 1.18 in)

3. Position the drilled hole downward and drain oil by moving the piston rod several times.

CAUTION:

Dispose of drained oil according to the law and local regulations.

COIL SPRING AND SHOCK ABSORBER

< UNIT DISASSEMBLY AND ASSEMBLY >

UNIT DISASSEMBLY AND ASSEMBLY

COIL SPRING AND SHOCK ABSORBER

Disassembly and Assembly

INFOID:000000007306937

DISASSEMBLY

1. Set the shock absorber in a vise, then loosen (without removing) the piston rod lock nut as shown.

CAUTION:

Do not remove piston rod lock nut at this time.

2. Compress the spring using tool until the shock absorber mounting insulator can be turned by hand.

WARNING:

Make sure that the pawls of the two tools are firmly hooked on the spring. The spring compressors must be tightened alternately and evenly so as not to tilt the spring.

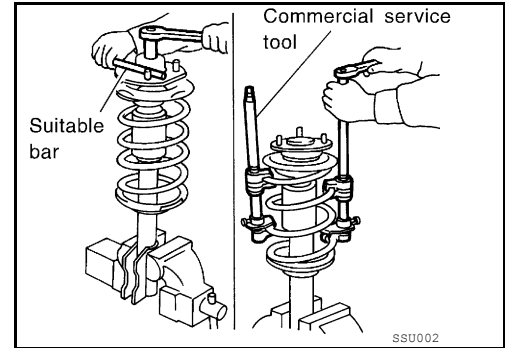

3. Remove the piston rod lock nut.
 - Discard the piston rod lock nut, use a new nut for assembly.

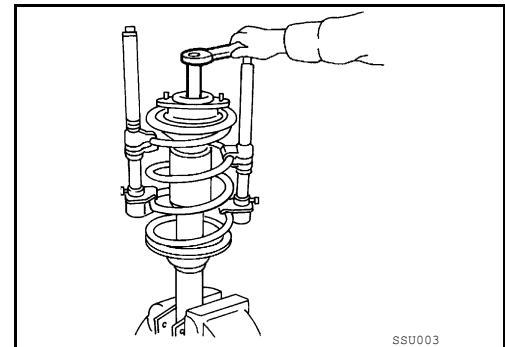

INSPECTION AFTER DISASSEMBLY

Shock Absorber Assembly

- Check for smooth operation through a full stroke, both compression and extension.
- Check for oil leakage on welded or gland packing portions.
- Check piston rod for cracks, deformation or other damage and replace if necessary.

Mounting Insulator and Rubber Parts

Check cemented rubber-to-metal portion for separation or cracks. Check rubber parts for deterioration and replace if necessary.

Coil Spring

- Check for cracks, deformation or other damage and replace if necessary.
- Check the free spring height.

Front spring free height

2WD : Refer to [FSU-22, "Spring Free Height"](#).

4WD : Refer to [FSU-22, "Spring Free Height"](#).

ASSEMBLY

COIL SPRING AND SHOCK ABSORBER

< UNIT DISASSEMBLY AND ASSEMBLY >

1. When installing coil spring on shock absorber, the lower end (2) and upper end (3) must be positioned as shown.
 - Shock absorber mounting insulator (1)
 - ← : Flat tail

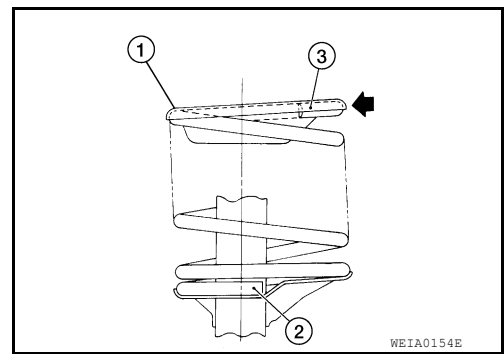

2. Install upper spring insulator (3) with studs located in line with lower shock mount and in lower seat step (2). The lower seat step (2) in the shock absorber assembly (1) faces outside of vehicle.
 - ⇐ : Front
3. Tighten the piston rod lock nut to specification. Refer to [FSU-12, "Component"](#).
 - Use a new piston rod lock nut for assembly.

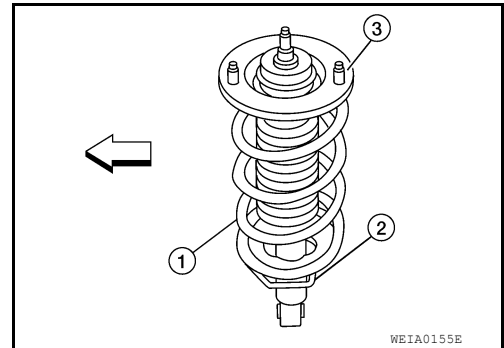

A
B
C
D
FSU
F
G
H
I
J
K
L
M
N
O
P

SERVICE DATA AND SPECIFICATIONS (SDS)

< SERVICE DATA AND SPECIFICATIONS (SDS)

SERVICE DATA AND SPECIFICATIONS (SDS)

SERVICE DATA AND SPECIFICATIONS (SDS)

General Specification (Front)

INFOID:000000007306938

Suspension type	Independent double wishbone coil over shock
Shock absorber type	Double-acting hydraulic
Stabilizer	Standard equipment

Spring Free Height

INFOID:000000007306939

2WD	325.5 ± 3 mm (12.8 ± 0.1 in)
4WD	335.0 ± 3 mm (13.2 ± 0.1 in)

Wheel Alignment (Unladen*1)

INFOID:000000007306940

Drive type		2WD	4WD
Camber *6 Degree minute (decimal degree)	Minimum	-0° 57' (-0.95°)	-0° 27' (-0.45°)
	Nominal	-0° 12' (-0.20°)	0° 18' (0.30°)
	Maximum	0° 33' (0.55°)	1° 03' (1.05°)
	Cross camber	0° 45' (0.75°) or less	0° 45' (0.75°) or less
Caster *6 Degree minute (decimal degree)	Minimum	2° 15' (2.25°)	1° 27' (1.45°)
	Nominal	3° 0' (3.00°)	2° 12' (2.20°)
	Maximum	3° 45' (3.75°)	2° 57' (2.95°)
	Cross caster	0° 45' (0.75°) or less	0° 45' (0.75°) or less
Kingpin inclination (reference only) Degree minute (decimal degree)		13° 33' (13.55°)	13° 0' (13.00°)

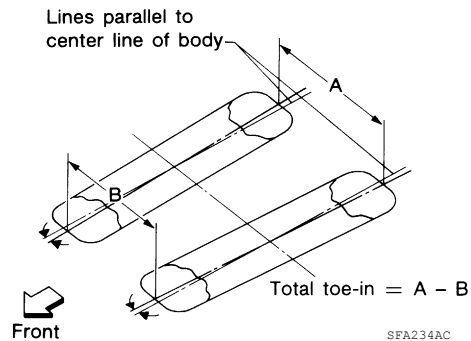

Total toe-in	Distance (A - B)	Minimum	In 0.5 mm (0.02 in)	In 0.5 mm (0.02 in)
		Nominal	In 2.5 mm (0.10 in)	In 2.5 mm (0.10 in)
		Maximum	In 4.5 mm (0.17 in)	In 4.5 mm (0.17 in)
	Angle Degree minute (decimal degree)	Minimum	In 0° 0' 36" (0.01°)	In 0° 0' 36" (0.01°)
		Nominal	In 0° 10' 12" (0.17°)	In 0° 10' 12" (0.17°)
		Maximum	In 0° 19' 48" (0.33°)	In 0° 19' 48" (0.33°)
Wheel turning angle (full turn)	Inside Degree minute (decimal degree)	34° 30' - 38° 30' *2 (34.50° - 38.50°)	34° 56' - 38° 56' *4 (34.93° - 38.93°)	
	Outside Degree minute (decimal degree)	30° 58' - 34° 58' *3 (30.97° - 34.97°)	31° 01' - 35° 01' *5 (31.02° - 35.02°)	

*1: Fuel, radiator coolant and engine oil full. Spare tire, jack, hand tools and mats in designated positions.

SERVICE DATA AND SPECIFICATIONS (SDS)

< SERVICE DATA AND SPECIFICATIONS (SDS)

*2: Target value 37° 30' (37.50°)

*3: Target value 33° 58' (33.97°)

*4: Target value 37° 56' (37.93°)

*5: Target value 34° 01' (34.02°)

*6: Some vehicles may be equipped with straight (non-adjustable) lower link bolts and washers. In order to adjust camber and caster on these vehicles, first replace the lower link bolts and washers with adjustable (cam) bolts and washers.

Ball Joint

INFOID:000000007306941

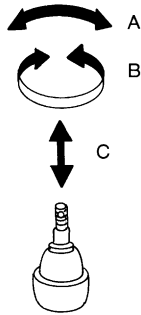

SFA858A

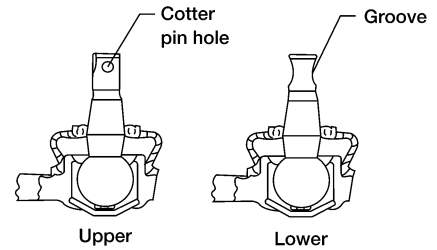

WEIA0076E

Swinging force (A)	Upper ball joint	8.1 – 103.2 N (0.8 – 10.5 kg-f, 1.8 – 23.2 lb-f) *1
	Lower ball joint	11.4 – 145.5 N (1.1 – 14.8 kg-f, 2.5 – 32.7 lb-f) *2
Turning torque (B)		0.5 - 6.4 N·m (0.05 - 0.65 kg-m, 4 - 57 in-lb)
Vertical end play (C)		0 mm (0 in)

*1 Measure at cotter pin hole

*2 Measure at groove

Wheelarch Height (Unladen*1)

INFOID:000000007306942

Unit: mm (in)

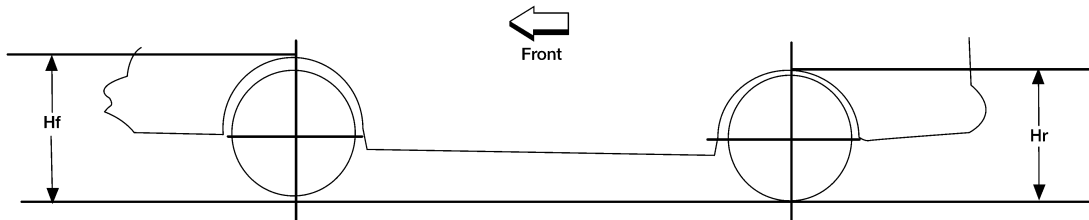

LEIA0085E

Drive type	2WD				4WD*2				4WD*3				
	Short		Long		Short		Long		Short		Long		
Wheel base	King Cab	Crew Cab	King Cab	Crew Cab	King Cab	Crew Cab	King Cab	Crew Cab	King Cab	Crew Cab	King Cab	Crew Cab	
Body	King Cab	Crew Cab	King Cab	Crew Cab	King Cab	Crew Cab	King Cab	Crew Cab	King Cab	Crew Cab	King Cab	Crew Cab	
Front wheel arch height (Hf)	P265/70R18	912 (35.91)	914 (35.98)	912 (35.91)	914 (35.98)	949 (37.36)	951 (37.44)	949 (37.36)	951 (37.44)	949 (37.36)	951 (37.44)	949 (37.36)	951 (37.44)
	P275/70R18	922 (36.30)	925 (36.42)	922 (36.30)	925 (36.42)	960 (37.80)	962 (37.87)	959 (37.76)	962 (37.87)	960 (37.80)	962 (37.87)	959 (37.76)	962 (37.87)
	P275/60R20	917 (36.10)	919 (36.18)	917 (36.10)	920 (36.22)	955 (37.60)	957 (37.68)	954 (37.56)	957 (37.68)	955 (37.60)	957 (37.68)	954 (37.56)	957 (37.68)

SERVICE DATA AND SPECIFICATIONS (SDS)

< SERVICE DATA AND SPECIFICATIONS (SDS)

Rear wheel arch height (Hr)	P265/ 70R18	952 (37.48)	954 (37.56)	950 (37.40)	951 (37.44)	991 (39.02)	994 (39.13)	989 (38.94)	991 (39.02)	991 (39.02)	993 (39.09)	989 (38.94)	991 (39.02)
	P275/ 70R18	962 (37.87)	965 (37.99)	960 (37.80)	962 (37.87)	1002 (39.45)	1004 (39.53)	1000 (39.37)	1002 (39.45)	1001 (39.41)	1004 (39.53)	1000 (39.37)	1002 (39.45)
	P275/ 60R20	957 (37.68)	959 (37.76)	955 (37.60)	956 (37.64)	996 (39.21)	999 (39.33)	995 (39.17)	996 (39.21)	996 (39.21)	998 (39.29)	995 (39.17)	996 (39.21)

*1: Fuel, radiator coolant and engine oil full. Spare tire, jack, hand tools and mats in designated positions.

*2: Without tow package.

*3: With tow package.