

A
LU

SECTION LU

ENGINE LUBRICATION SYSTEM

C

CONTENTS

D
E

PRECAUTION	2	OIL FILTER	11	F
PRECAUTIONS	2	Removal and Installation	11	
Precaution for Supplemental Restraint System (SRS) "AIR BAG" and "SEAT BELT PRE-TENSIONER"	2	REMOVAL AND INSTALLATION	12	G
Precaution for Liquid Gasket	2	OIL COOLER	12	
PREPARATION	4	Exploded View	12	H
PREPARATION	4	Removal and Installation	12	
Special Service Tool	4	OIL PUMP	14	
Commercial Service Tool	4	Exploded View	14	I
SYSTEM DESCRIPTION	6	Removal and Installation	14	
LUBRICATION SYSTEM	6	UNIT DISASSEMBLY AND ASSEMBLY ...	16	J
Lubrication Circuit	6	OIL PUMP	16	
Schematic	7	Disassembly and Assembly	16	K
PERIODIC MAINTENANCE	8	SERVICE DATA AND SPECIFICATIONS (SDS)	18	
ENGINE OIL	8	SERVICE DATA AND SPECIFICATIONS (SDS)	18	L
Inspection	8	Standard and Limit	18	
Changing Engine Oil	9			M

N
O
P

PRECAUTIONS

< PRECAUTION >

PRECAUTION

PRECAUTIONS

Precaution for Supplemental Restraint System (SRS) "AIR BAG" and "SEAT BELT PRE-TENSIONER"

INFOID:000000008926710

The Supplemental Restraint System such as "AIR BAG" and "SEAT BELT PRE-TENSIONER", used along with a front seat belt, helps to reduce the risk or severity of injury to the driver and front passenger for certain types of collision. This system includes seat belt switch inputs and dual stage front air bag modules. The SRS system uses the seat belt switches to determine the front air bag deployment, and may only deploy one front air bag, depending on the severity of a collision and whether the front occupants are belted or unbelted. Information necessary to service the system safely is included in the SR and SB section of this Service Manual.

WARNING:

- To avoid rendering the SRS inoperative, which could increase the risk of personal injury or death in the event of a collision which would result in air bag inflation, all maintenance must be performed by an authorized NISSAN/INFINITI dealer.
- Improper maintenance, including incorrect removal and installation of the SRS, can lead to personal injury caused by unintentional activation of the system. For removal of Spiral Cable and Air Bag Module, see the SR section.
- Do not use electrical test equipment on any circuit related to the SRS unless instructed to in this Service Manual. SRS wiring harnesses can be identified by yellow and/or orange harnesses or harness connectors.

PRECAUTIONS WHEN USING POWER TOOLS (AIR OR ELECTRIC) AND HAMMERS

WARNING:

- When working near the Airbag Diagnosis Sensor Unit or other Airbag System sensors with the Ignition ON or engine running, DO NOT use air or electric power tools or strike near the sensor(s) with a hammer. Heavy vibration could activate the sensor(s) and deploy the air bag(s), possibly causing serious injury.
- When using air or electric power tools or hammers, always switch the Ignition OFF, disconnect the battery and wait at least 3 minutes before performing any service.

Precaution for Liquid Gasket

INFOID:000000007948769

REMOVAL OF LIQUID GASKET

- After removing the bolts and nuts, separate the mating surface and remove the old liquid gasket using Tool.

Tool number : KV10111100 (J-37228)

CAUTION:

Do not damage the mating surfaces.

- Tap the seal cutter to insert it (1).
- In areas where the Tool is difficult to use, lightly tap to slide it (2).

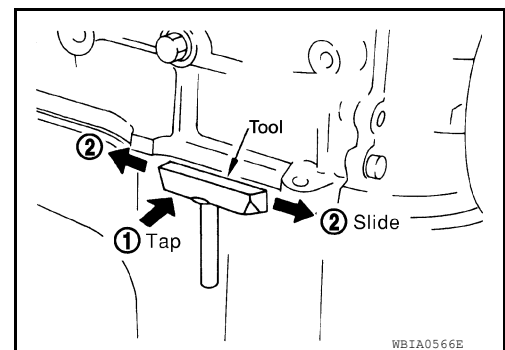

WBIA0566E

LIQUID GASKET APPLICATION PROCEDURE

PRECAUTIONS

< PRECAUTION >

1. Remove the old liquid gasket adhering to the gasket application surface and the mating surface using suitable tool.
 - Remove the liquid gasket completely from the groove of the liquid gasket application surface, bolts, and bolt holes.
2. Thoroughly clean the mating surfaces and remove adhering moisture, grease and foreign material.

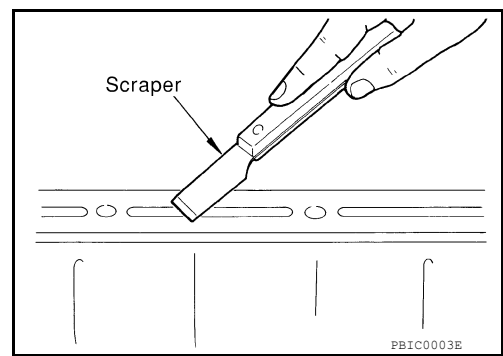

3. Attach the liquid gasket tube to the Tool.

Tool number : WS39930000 (—)

Use Genuine RTV Silicone Sealant or equivalent. Refer to [GI-17, "Recommended Chemical Products and Sealants"](#).

4. Apply the liquid gasket without breaks to the specified location with the specified dimensions.

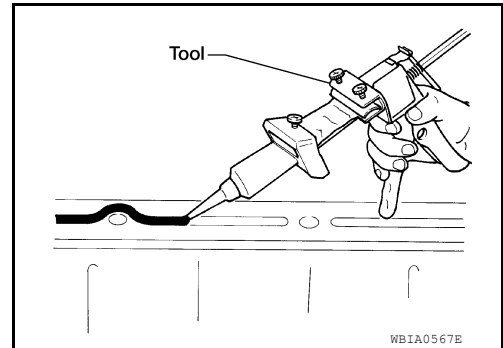

- If there is a groove for the liquid gasket application, apply the liquid gasket to the groove.
- Normally apply the liquid gasket on the inside edge of the bolt holes. Also apply to the outside edge of the bolt holes when specified in the procedure.
- Within five minutes of liquid gasket application, install the mating component.
- If the liquid gasket protrudes, wipe it off immediately.
- Do not retighten after the installation.
- Wait 30 minutes or more after installation before refilling the engine with oil or coolant.

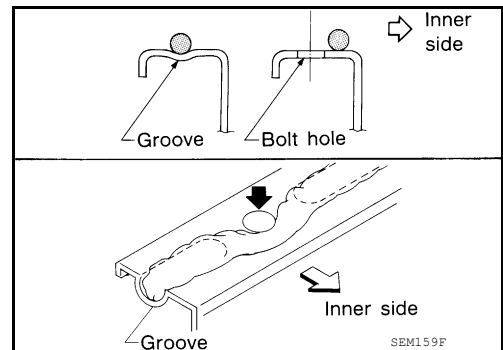

CAUTION:

Carefully follow all of the warnings, cautions, notes, and procedures contained in this manual.

PREPARATION

< PREPARATION >

PREPARATION

PREPARATION

Special Service Tool

INFOID:000000007948770

The actual shapes of Kent-Moore tools may differ from those of special service tools illustrated here.

Tool number (Kent-Moore No.) Tool name	Description
ST25051001 (J-25695-1) Oil pressure gauge	Measuring oil pressure Maximum measuring range: 2,452 kPa (25 kg/cm², 356 psi)
ST25052000 (J-25695-2) Hose	Adapting oil pressure gauge to cylinder block
KV10111100 (J-37228) Seal cutter	Removing steel oil pan and rear timing chain case
KV10115801 (J-38956) Oil filter wrench	Removing and installing oil filter a: 64.3 mm (2.531 in)
WS39930000 (—) Tube presser	Pressing the tube of liquid gasket

Commercial Service Tool

INFOID:000000007948771

PREPARATION

< PREPARATION >

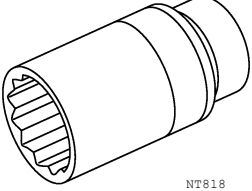
Tool name	Description
<p>Power tool</p>  <p style="text-align: center;">PIIB1407E</p>	<p>Loosening nuts, screws and bolts</p>
<p>Deep socket</p>  <p style="text-align: center;">NT818</p>	<p>Removing and installing oil pressure switch Deep socket 26 mm</p>

A

LU

C

D

E

F

G

H

I

J

K

L

M

N

O

P

LUBRICATION SYSTEM

< SYSTEM DESCRIPTION >

SYSTEM DESCRIPTION

LUBRICATION SYSTEM

Lubrication Circuit

INFOID:000000007948772

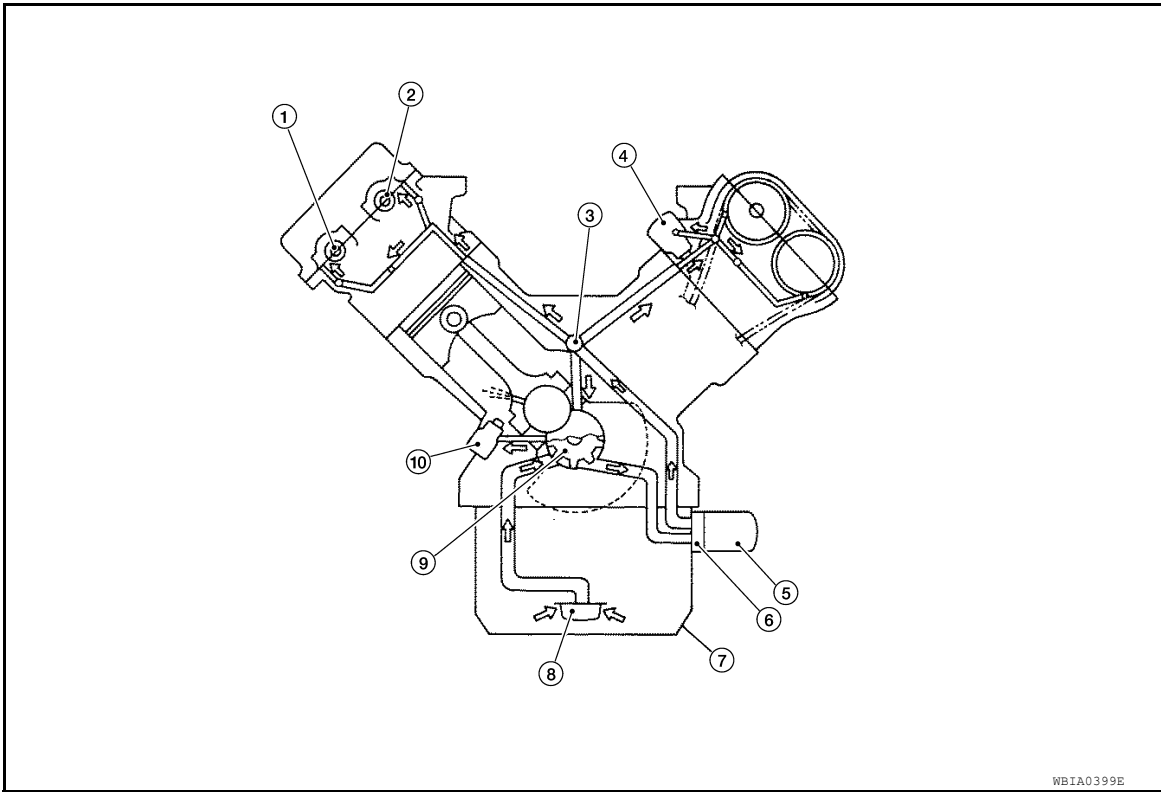

- | | | |
|----------------------------------|--------------------|--------------------|
| 1. Exhaust camshaft | 2. Intake camshaft | 3. Main oil galley |
| 4. Chain tensioner (Left bank) | 5. Oil filter | 6. Oil cooler |
| 7. Oil pan | 8. Oil strainer | 9. Oil pump |
| 10. Chain tensioner (Right bank) | | |

LUBRICATION SYSTEM

< SYSTEM DESCRIPTION >

Schematic

INFOID:000000007948773

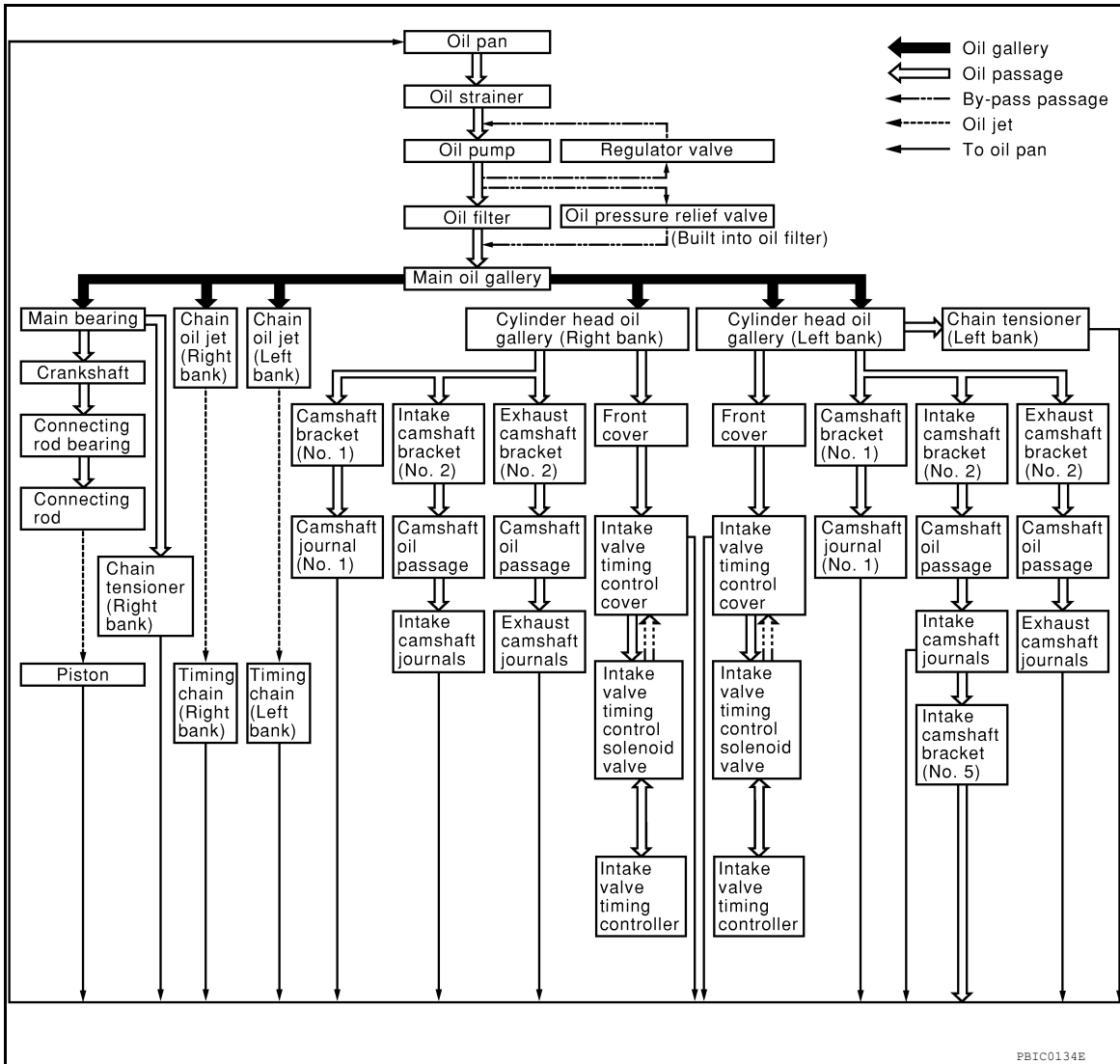

PBIC0134E

A
LU
C
D
E
F
G
H
I
J
K
L
M
N
O
P

ENGINE OIL

< PERIODIC MAINTENANCE >

PERIODIC MAINTENANCE

ENGINE OIL

Inspection

INFOID:000000007948774

OIL LEVEL

- Before starting the engine make sure the vehicle is parked on a flat and level surface, then check the oil level. If the engine is already running, turn it off and allow 10 minutes before checking.
- Check that the oil level is within the low (L) and high (H) range as indicated on the dipstick.
- If the engine oil level is out of range, add oil as necessary. Refer to [MA-16, "FOR NORTH AMERICA : Fluids and Lubricants"](#), (United States and Canada), [MA-17, "FOR MEXICO : Fluids and Lubricants"](#) (Mexico).



OIL APPEARANCE

- Check the engine oil for a white milky appearance or excessive contamination.
- If the engine oil is milky, it is highly probable that it is contaminated with engine coolant. Repair the broken parts.

OIL LEAKS

Check for oil leaks around the following areas:

- Oil pan
- Oil pan drain plug
- Oil pressure switch
- Oil filter
- Oil cooler
- Intake valve timing control cover
- Intake valve timing control solenoid valve
- Front cover
- Mating surface between cylinder block and cylinder head
- Mating surface between cylinder head and rocker cover
- Crankshaft oil seal (front and rear)

OIL PRESSURE CHECK

WARNING:

- **Be careful not to burn yourself, as engine oil may be hot.**
 - **Put the A/T shift selector in the Park "P" position.**
1. Check the engine oil level. Refer to [LU-8, "Inspection"](#).
 2. Remove engine under cover (without off road package) or skid plate (with off road package). Refer to [EXT-15, "Removal and Installation"](#).
 3. Disconnect the oil pressure switch harness connector.
 4. Remove the oil pressure switch (A).

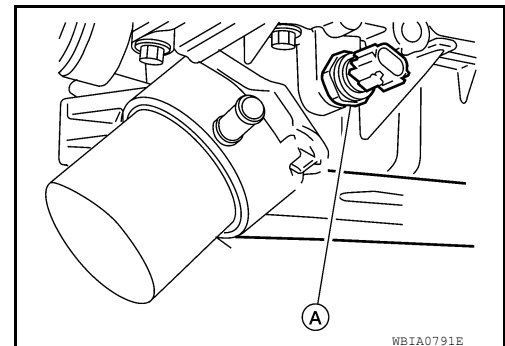

ENGINE OIL

< PERIODIC MAINTENANCE >

5. Install Tools.

Tool number : ST25051001 (J-25695-1)
: ST25052000 (J-25695-2)

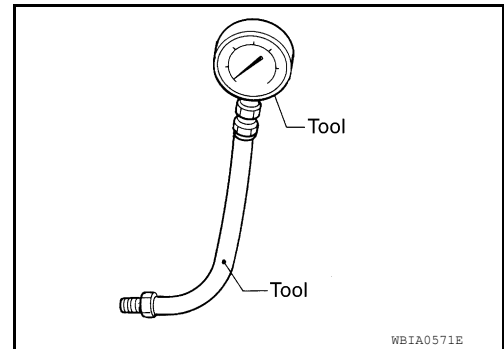

6. Start the engine and warm it up to normal operating temperature.
7. Check the engine oil pressure with engine running under no-load. Refer to [LU-18, "Standard and Limit"](#).

CAUTION:

If the difference between the test results and the specification is extreme, check the oil passages and oil pump for leaks and blockages.

8. After the inspections, install oil pressure switch as follows:
 - a. Remove old liquid gasket adhering to oil pressure switch and engine.
 - b. Apply liquid gasket and tighten oil pressure switch to the specification.
Use Genuine RTV Silicone Sealant or equivalent. Refer to [GI-17, "Recommended Chemical Products and Sealants"](#).

Oil pressure switch torque : 14.8 N·m (1.5 kg-m, 11 ft-lb)

- c. After warming up engine, make sure there are no engine oil leaks.
9. Install the engine under cover (without off road package) or skid plate (with off road package). Refer to [EXT-15, "Removal and Installation"](#).

Changing Engine Oil

INFOID:000000007948775

WARNING:

- Be careful not to burn yourself, as the engine oil is hot.
- Prolonged and repeated contact with used engine oil may cause skin cancer. Try to avoid direct skin contact with used engine oil. If skin contact is made, wash thoroughly with soap or hand cleaner as soon as possible.

1. Remove engine under cover (without off road package) or skid plate (with off road package). Refer to [EXT-15, "Removal and Installation"](#).
2. Warm up engine, and check for engine oil leaks. Refer to [LU-8, "Inspection"](#).
3. Stop engine and wait for 10 minutes.
4. Loosen oil filler cap, then remove drain plug.
5. Drain engine oil.
6. Install drain plug with new washer.

CAUTION:

- Be sure to clean drain plug and install with new washer.

Oil pan drain plug : 34.3 N·m (3.5 kg-m, 25 ft-lb)

7. Refill with new engine oil. Refer to [MA-16, "FOR NORTH AMERICA : Fluids and Lubricants"](#), (United States and Canada), [MA-17, "FOR MEXICO : Fluids and Lubricants"](#). (Mexico).

CAUTION:

- The refill capacity depends on the engine oil temperature and drain time. Use these specifications for reference only.

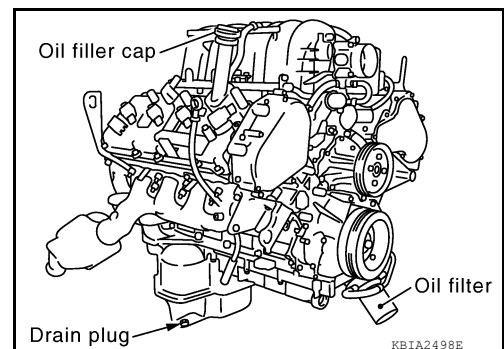

ENGINE OIL

< PERIODIC MAINTENANCE >

- **Always use the oil level gauge to determine when the proper amount of engine oil is in the engine.**
8. Warm up engine and check area around drain plug and oil filter for oil leaks.
 9. Stop engine and wait for 10 minutes.
 10. Install engine under cover (without off road package) or skid plate (with off road package). Refer to [EXT-15. "Removal and Installation"](#).
 11. Check engine oil level. Refer to [LU-8. "Inspection"](#).

OIL FILTER

< PERIODIC MAINTENANCE >

OIL FILTER

Removal and Installation

INFOID:000000007948776

REMOVAL

1. Remove the engine under cover (without off road package) or skid plate (with off road package). Refer to [EXT-15, "Removal and Installation"](#).
2. Drain the engine oil. Refer to [LU-9, "Changing Engine Oil"](#).
3. Remove the oil filter using Tool.

Tool number : KV10115801 (J-38956)

WARNING:

- Be careful not to get burned when the engine and engine oil are hot.

CAUTION:

- The oil filter is provided with a relief valve.
- Use Genuine NISSAN oil filter or equivalent.
- When removing, prepare a shop cloth to absorb any engine oil leaks or spills.
- Do not allow engine oil to adhere to the drive belt.
- Completely wipe off any engine oil that adheres to the engine and the vehicle.

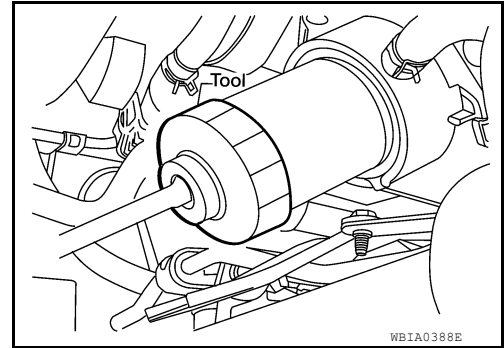

INSTALLATION

1. Remove foreign materials adhering to the oil filter installation surface.
2. Apply engine oil to the oil seal circumference of the new oil filter.

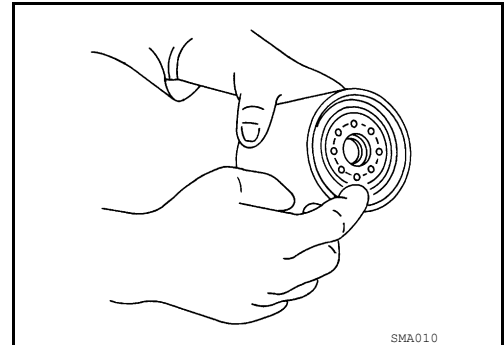

3. Screw the oil filter manually until it touches the installation surface, then tighten it by 2/3 turn. Or tighten to specification.

Oil filter : 18.0 N·m (1.8 kg-m, 13 ft-lb)

4. Refill the engine with new engine oil. Refer to [LU-9, "Changing Engine Oil"](#).
5. Inspect the engine for oil leaks. Follow the "INSPECTION AFTER INSTALLATION" procedure.
6. Install the engine under cover (without off road package) or skid plate (with off road package). Refer to [EXT-15, "Removal and Installation"](#).

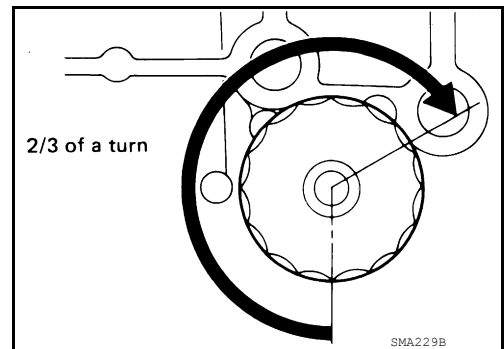

INSPECTION AFTER INSTALLATION

1. Check the engine oil level. Refer to [LU-8, "Inspection"](#).
2. Start the engine and check for engine oil leaks.
3. Stop the engine and wait for 10 minutes.
4. Check the engine oil level and add engine oil as required.

OIL COOLER

< REMOVAL AND INSTALLATION >

REMOVAL AND INSTALLATION

OIL COOLER

Exploded View

INFOID:000000007948777

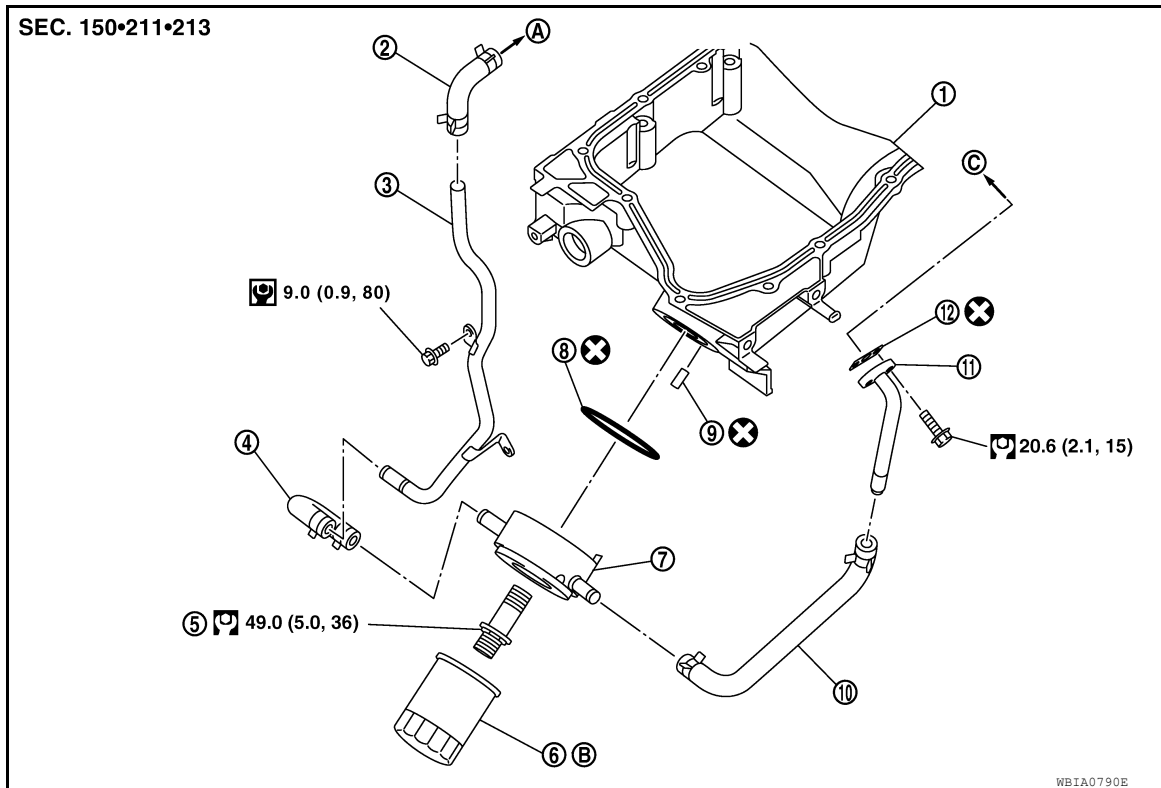

- | | | |
|--------------------------|-----------------------------------|----------------------|
| 1. Oil pan (Upper) | 2. Water hose | 3. Water pipe |
| 4. Water hose | 5. Connector bolt | 6. Oil filter |
| 7. Oil cooler | 8. O-ring | 9. Relief valve |
| 10. Water hose | 11. Connector pipe | 12. Gasket |
| A. To thermostat housing | B. Refer to LU-11 | C. To cylinder block |

Removal and Installation

INFOID:000000007948778

WARNING:

Be careful not to burn yourself, as the engine oil and engine coolant may be hot.

NOTE:

When removing components such as hoses, tubes/lines, etc., cap or plug openings to prevent fluid from spilling.

REMOVAL

1. Remove the engine under cover (without off road package) or skid plate (with off road package). Refer to [EXT-15, "Removal and Installation"](#).
2. Drain engine coolant from the radiator. Refer to [CO-11, "Changing Engine Coolant"](#).
3. Disconnect water hoses from the oil cooler.
CAUTION:
Do not spill engine coolant on the drive belt.
4. Remove oil filter. Refer to [LU-11, "Removal and Installation"](#).
CAUTION:
Do not spill engine oil on the drive belts.
5. Remove connector bolt, oil cooler and O-ring.

OIL COOLER

< REMOVAL AND INSTALLATION >

CAUTION:

Do not reuse O-ring.

INSPECTION AFTER REMOVAL

Oil Cooler

Check oil cooler for cracks. Check oil cooler for clogging by blowing compressed air through engine coolant inlet. If necessary, replace oil cooler assembly.

Relief Valve

Inspect relief valve for movement, cracks and breaks by pushing the ball. If replacement is necessary, remove the valve by prying it out using a suitable tool. Install a new valve by tapping it in place.

INSTALLATION

Installation is in the reverse order of removal, paying attention to the following:

- Confirm that no foreign objects are adhering to the sealing surfaces of the oil cooler or oil pan.
- Tighten the connector bolt after aligning the protrusion of the oil cooler with the stopper on the oil pan (upper).

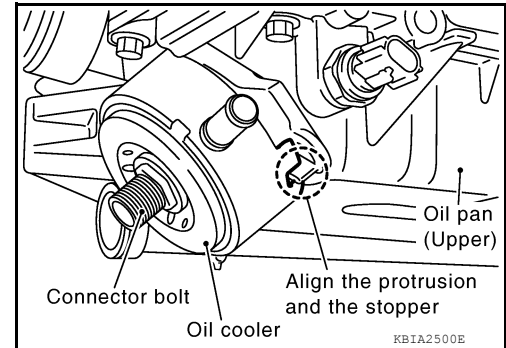

INSPECTION AFTER INSTALLATION

- Before starting engine, check oil/fluid levels including engine coolant and engine oil. If less than required quantity, fill to the specified level. Refer to [MA-16, "FOR NORTH AMERICA : Fluids and Lubricants"](#) (United States and Canada) or [MA-17, "FOR MEXICO : Fluids and Lubricants"](#) (Mexico).
- Use procedure below to check for fuel leakage.
- Turn ignition switch ON (with engine stopped). With fuel pressure applied to fuel piping, check for fuel leakage at connection points.
- Start engine. With engine speed increased, check again for fuel leakage at connection points.
- Run engine to check for unusual noise and vibration.

NOTE:

If hydraulic pressure inside timing chain tensioner drops after removal and installation, slack in the guide may generate a pounding noise during and just after engine start. However, this is normal. Noise will stop after hydraulic pressure rises.

- Warm up engine thoroughly to make sure there is no leakage of fuel, exhaust gas, or any oils/fluids including engine oil and engine coolant.
- Bleed air from passages in lines and hoses, such as in cooling system.
- After cooling down engine, again check oil/fluid levels including engine oil and engine coolant. Refill to specified level, if necessary.
- Summary of the inspection items:

Item		Before starting engine	Engine running	After engine stopped
Engine coolant		Level	Leakage	Level
Engine oil		Level	Leakage	Level
Transmission/ transaxle fluid	A/T and CVT Models	Leakage	Level/Leakage	Leakage
	M/T Models	Level/Leakage	Leakage	Level/Leakage
Other oils and fluids*		Level	Leakage	Level
Fuel		Leakage	Leakage	Leakage
Exhaust gas		—	Leakage	—

*Power steering fluid, brake fluid, etc.

OIL PUMP

< REMOVAL AND INSTALLATION >

OIL PUMP

Exploded View

INFOID:000000007948779

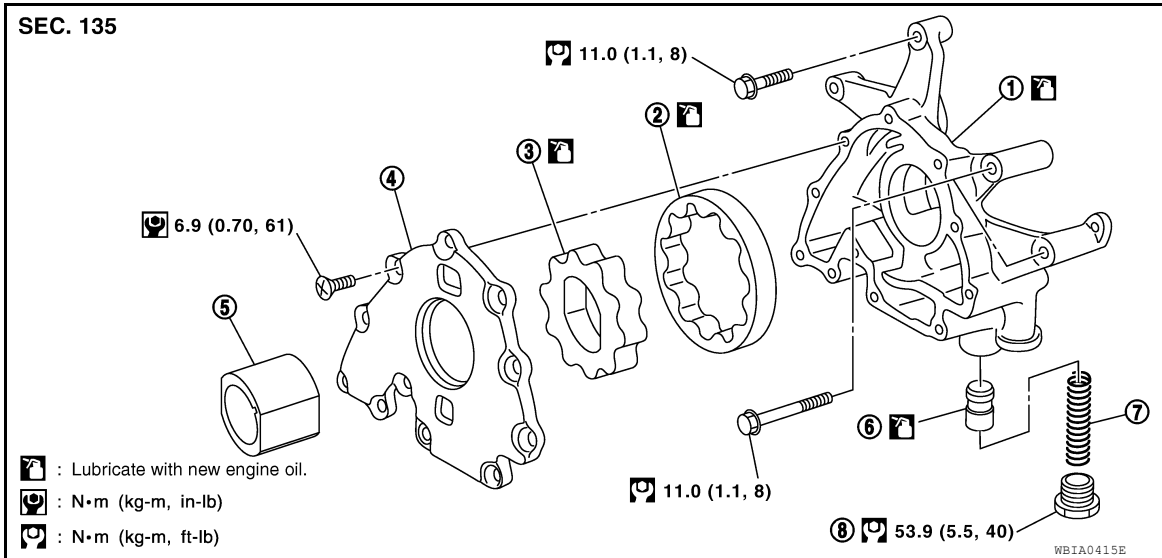

- | | | |
|---------------------|--------------------------|--------------------|
| 1. Oil pump body | 2. Outer rotor | 3. Inner rotor |
| 4. Oil pump cover | 5. Oil pump drive spacer | 6. Regulator valve |
| 7. Regulator spring | 8. Regulator plug | |

Removal and Installation

INFOID:000000007948780

REMOVAL

1. Remove timing chain cover. Refer to [EM-50, "Removal and Installation"](#).
2. Remove the oil pump drive spacer.
3. Remove the oil pump.

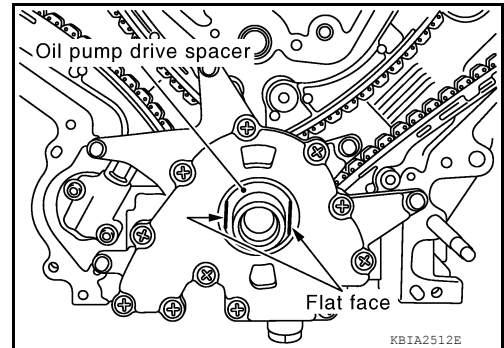

INSTALLATION

Installation is in the reverse order of removal.

- Align the crankshaft key and the flat face of the inner rotor before inserting the oil pump drive spacer.
- Rotate the oil pump inner rotor by hand until the crankshaft key and the inner rotor are aligned properly.
- Then tap lightly until the oil pump drive spacer reaches the end.

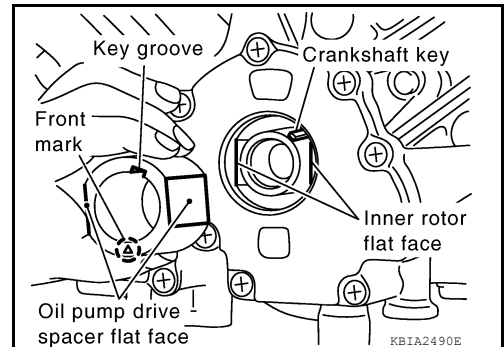

INSPECTION AFTER INSTALLATION

OIL PUMP

< REMOVAL AND INSTALLATION >

- Start the engine, and check for engine oil and engine coolant leaks and repair as necessary.
- Stop engine and wait 10 minutes.
- Check level and add engine oil as required. Refer to [LU-8](#).

A

LU

C

D

E

F

G

H

I

J

K

L

M

N

O

P

OIL PUMP

< UNIT DISASSEMBLY AND ASSEMBLY >

UNIT DISASSEMBLY AND ASSEMBLY

OIL PUMP

Disassembly and Assembly

INFOID:000000007948781

DISASSEMBLY

1. Remove oil pump cover.
2. Remove inner rotor and outer rotor from oil pump body.
3. Remove the regulator plug, regulator spring and regulator valve.

INSPECTION AFTER DISASSEMBLY

Clearance of Oil Pump Parts

- Measure radial clearance using a suitable tool.

Body to outer rotor (position 1) : Refer to [LU-18](#).

Inner rotor to outer rotor tip (position 2) : Refer to [LU-18](#).

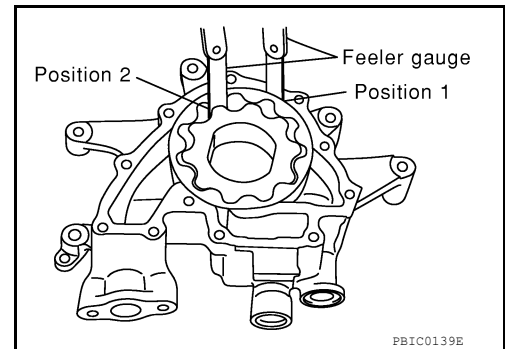

- Measure side clearance using suitable tools.

Body to inner rotor (position 3) : Refer to [LU-18](#).

Body to outer rotor (position 4) : Refer to [LU-18](#).

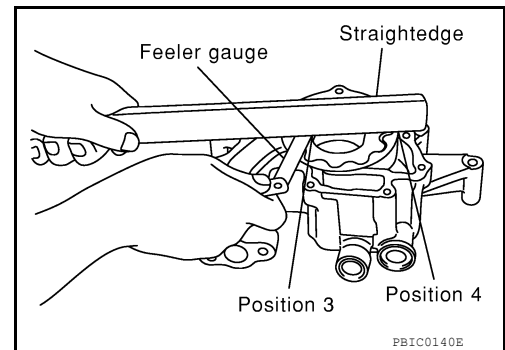

- Calculate the clearance between inner rotor and oil pump body as follows.

1. Measure the outer diameter of protruded portion of inner rotor (position 5) using suitable tool.

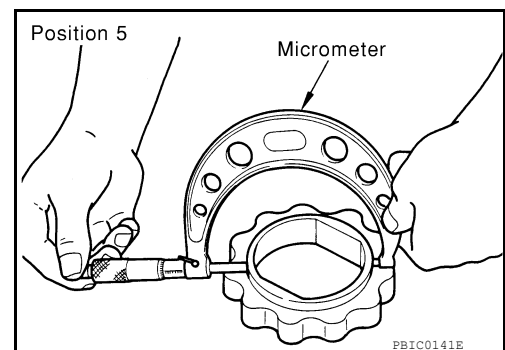

OIL PUMP

< UNIT DISASSEMBLY AND ASSEMBLY >

2. Measure the inner diameter of oil pump body to brazed portion (position 6) using suitable tool.

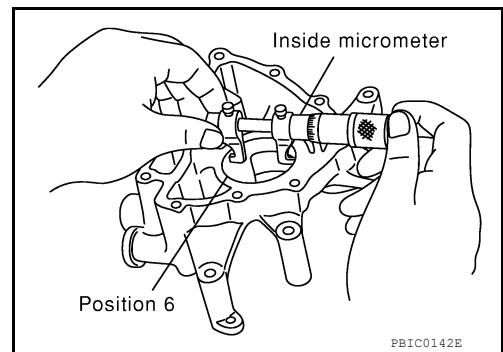

3. Calculate the clearance using the following formula.
 - (Clearance) = (Inner diameter of oil pump body) - (Outer diameter of inner rotor)

Inner rotor to brazed portion of housing clearance : Refer to [LU-18](#).

Regulator Valve Clearance

Check regulator valve to oil pump cover clearance using the following formula.

- (Clearance) = D1 (Valve hole diameter) - D2 (Outer Diameter of valve)

Regulator valve to oil pump cover : Refer to [LU-18](#).

CAUTION:

- Coat regulator valve with engine oil.
- Check that it falls smoothly into the regulator valve hole by its own weight.

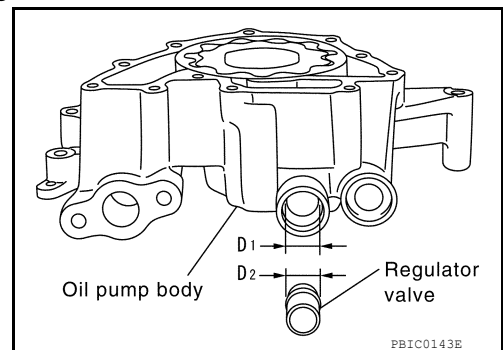

ASSEMBLY

Assembly is in the reverse order of disassembly.

NOTE:

Install the inner rotor and outer rotor with the punched marks on the oil pump cover side.

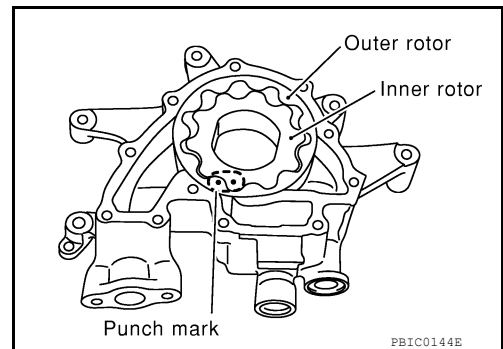

SERVICE DATA AND SPECIFICATIONS (SDS)

< SERVICE DATA AND SPECIFICATIONS (SDS)

SERVICE DATA AND SPECIFICATIONS (SDS)

SERVICE DATA AND SPECIFICATIONS (SDS)

Standard and Limit

INFOID:000000007948782

OIL PRESSURE

Unit: kPa (kg/cm², psi)

Engine speed	Approximate discharge oil pressure*
Idle speed	More than 98 (1.0, 14)
2,000 rpm	More than 294 (3.0, 43)
6,000 rpm	More than 392 (4.0, 57)

*: Engine oil temperature at 80°C (176°F)

OIL PUMP

Unit: mm (in)

Body to outer rotor radial clearance	0.114 - 0.200 (0.0045 - 0.0079)
Inner rotor to outer rotor tip clearance	Below 0.180 (0.0071)
Body to inner rotor side clearance	0.030 - 0.070 (0.0012 - 0.0028)
Body to outer rotor side clearance	0.030 - 0.090 (0.0012 - 0.0035)
Inner rotor to brazed portion of housing clearance	0.045 - 0.091 (0.0018 - 0.0036)

REGULATOR VALVE

Unit: mm (in)

Regulator valve to oil pump cover clearance	0.040 - 0.097 (0.0016 - 0.0038)
---	---------------------------------

ENGINE OIL CAPACITY (APPROXIMATE)

Unit: ℓ (US qt, Imp qt)

Drain and refill	With oil filter change	6.5 (6-7/8, 5-3/4)
	Without oil filter change	6.2 (6-1/2, 5-1/2)
Dry engine (engine overhaul)		7.6 (8, 6-3/4)