

SECTION **FSU**
FRONT SUSPENSION

A
B
C
D
F
G
H
I
J
K
L
M
N
O
P

FSU

CONTENTS

PRECAUTION	2	Disposal	11
PRECAUTIONS	2	STABILIZER BAR	12
Precaution for Supplemental Restraint System (SRS) "AIR BAG" and "SEAT BELT PRE-TENSIONER"	2	Removal and Installation	12
Precaution	2	UPPER LINK	13
PREPARATION	3	Removal and Installation	13
PREPARATION	3	Inspection	13
Special Service Tool	3	LOWER LINK	15
Commercial Service Tool	3	Removal and Installation	15
SYMPTOM DIAGNOSIS	4	Inspection	15
NOISE, VIBRATION, AND HARSHNESS (NVH) TROUBLESHOOTING	4	UPPER BALL JOINT AND LOWER BALL JOINT	17
NVH Troubleshooting Chart	4	Removal and Installation	17
PERIODIC MAINTENANCE	5	KNUCKLE	18
ON-VEHICLE SERVICE	5	Removal and Installation	18
Front Suspension Parts	5	UNIT DISASSEMBLY AND ASSEMBLY ...	20
Front Wheel Alignment	5	COIL SPRING AND SHOCK ABSORBER	20
KNUCKLE	9	Disassembly and Assembly	20
On-Vehicle Inspection and Service	9	SERVICE DATA AND SPECIFICATIONS (SDS)	22
REMOVAL AND INSTALLATION	10	SERVICE DATA AND SPECIFICATIONS (SDS)	22
FRONT SUSPENSION ASSEMBLY	10	General Specification (Front)	22
Exploded View	10	Spring Free Height	22
COIL SPRING AND SHOCK ABSORBER	11	Wheel Alignment (Unladen*1)	22
Removal and Installation	11	Ball Joint	23
		Wheelarch Height (Unladen*1)	23

PRECAUTIONS

< PRECAUTION >

PRECAUTION

PRECAUTIONS

Precaution for Supplemental Restraint System (SRS) "AIR BAG" and "SEAT BELT PRE-TENSIONER"

INFOID:000000009885590

The Supplemental Restraint System such as "AIR BAG" and "SEAT BELT PRE-TENSIONER", used along with a front seat belt, helps to reduce the risk or severity of injury to the driver and front passenger for certain types of collision. This system includes seat belt switch inputs and dual stage front air bag modules. The SRS system uses the seat belt switches to determine the front air bag deployment, and may only deploy one front air bag, depending on the severity of a collision and whether the front occupants are belted or unbelted. Information necessary to service the system safely is included in the SR and SB section of this Service Manual.

WARNING:

- To avoid rendering the SRS inoperative, which could increase the risk of personal injury or death in the event of a collision which would result in air bag inflation, all maintenance must be performed by an authorized NISSAN/INFINITI dealer.
- Improper maintenance, including incorrect removal and installation of the SRS, can lead to personal injury caused by unintentional activation of the system. For removal of Spiral Cable and Air Bag Module, see the SR section.
- Do not use electrical test equipment on any circuit related to the SRS unless instructed to in this Service Manual. SRS wiring harnesses can be identified by yellow and/or orange harnesses or harness connectors.

PRECAUTIONS WHEN USING POWER TOOLS (AIR OR ELECTRIC) AND HAMMERS

WARNING:

- When working near the Airbag Diagnosis Sensor Unit or other Airbag System sensors with the Ignition ON or engine running, DO NOT use air or electric power tools or strike near the sensor(s) with a hammer. Heavy vibration could activate the sensor(s) and deploy the air bag(s), possibly causing serious injury.
- When using air or electric power tools or hammers, always switch the Ignition OFF, disconnect the battery, and wait at least 3 minutes before performing any service.

Precaution

INFOID:000000009885591

- When installing the rubber bushings, the final tightening must be done under unladen condition and with the tires on level ground. Oil will shorten the life of the rubber bushings, so wipe off any spilled oil immediately.
- Unladen condition means the fuel tank, engine coolant and lubricants are at the full specification. The spare tire, jack, hand tools, and mats are in their designated positions.
- After installing suspension components, check the wheel alignment.
- Lock nuts are not reusable. Always use new lock nuts for installation. New lock nuts are pre-oiled, do not apply any additional lubrication.

PREPARATION

< PREPARATION >

PREPARATION

PREPARATION

Special Service Tool

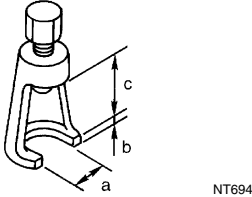
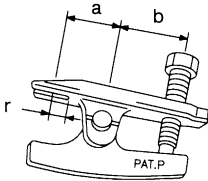
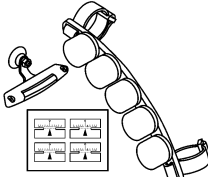

INFOID:000000009885592

The actual shapes of Kent-Moore tools may differ from those of special service tools illustrated here.

Tool number (Kent-Moore No.) Tool name	Description
ST29020001 (J-24319-01) Gear arm puller  NT694	Removing ball joint for steering knuckle a: 34 mm (1.34 in) b: 6.5 mm (0.256 in) c: 61.5 mm (2.421 in)
HT72520000 (J-25730-A) Ball joint remover  NT546	Removing tie-rod outer end a: 33 mm (1.30 in) b: 50 mm (1.97 in) r: 11.5 mm (0.453 in)
— (J-49286-1) Drift and pull gauge  AWEIA0156ZZ	Measuring drift and pull

Commercial Service Tool

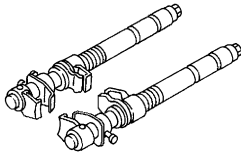
INFOID:000000009885593

Tool name	Description
Spring compressor  NT717	Removing and installing coil spring
Power tool  PIIB1407E	Loosening nuts, screws and bolts

NOISE, VIBRATION, AND HARSHNESS (NVH) TROUBLESHOOTING

< SYMPTOM DIAGNOSIS >

SYMPTOM DIAGNOSIS

NOISE, VIBRATION, AND HARSHNESS (NVH) TROUBLESHOOTING

NVH Troubleshooting Chart

INFOID:000000009885594

Use the chart below to help you find the cause of the symptom. Repair or replace parts as necessary.

Reference page		FSU-10	FSU-11	FSU-10	FSU-10	FSU-20	FSU-10	FSU-5	FSU-12	DLN-128, "NVH Troubleshooting Chart" (2F1310)	DLN-161, "NVH Troubleshooting Chart"	FAX-4, "NVH Troubleshooting Chart"	FAX-4, "NVH Troubleshooting Chart"	WT-44, "NVH Troubleshooting Chart"	WT-44, "NVH Troubleshooting Chart"	BR-5, "NVH Troubleshooting Chart"	ST-5, "NVH Troubleshooting Chart"
Possible Cause and SUSPECTED PARTS		Improper installation, looseness	Shock absorber deformation,	Bushing or mounting deterioration	Parts interference	Spring fatigue	Suspension looseness	Incorrect wheel alignment	Stabilizer bar fatigue	PROPELLER SHAFT	FRONT FINAL DRIVE	DRIVE SHAFT	WHEEL HUB	TIRES	ROAD WHEEL	BRAKES	STEERING
Symptom	Noise	x	x	x	x	x	x			x	x	x	x	x	x	x	x
	Shake	x	x	x	x		x			x		x	x	x	x	x	x
	Vibration	x	x	x	x	x				x		x	x	x			x
	Shimmy	x	x	x	x			x					x	x	x	x	x
	Shudder	x	x	x									x	x	x	x	x
	Poor quality ride or handling	x	x	x	x	x		x	x				x	x	x		

x: Applicable

ON-VEHICLE SERVICE

< PERIODIC MAINTENANCE >

PERIODIC MAINTENANCE

ON-VEHICLE SERVICE

Front Suspension Parts

INFOID:000000009885595

Check front suspension parts for excessive play, cracks, wear and other damage.

- Shake each front wheel to check for excessive play. If looseness is noted, inspect wheel bearing end play, then check ball joint end play. Refer to [FAX-5, "On-Vehicle Inspection and Service"](#) and [FSU-13, "Inspection"](#).
- Make sure that the cotter pin is inserted (4WD only).
- Retighten all nuts and bolts to the specified torque.

Suspension component torque : Refer to [FSU-10, "Exploded View"](#) .

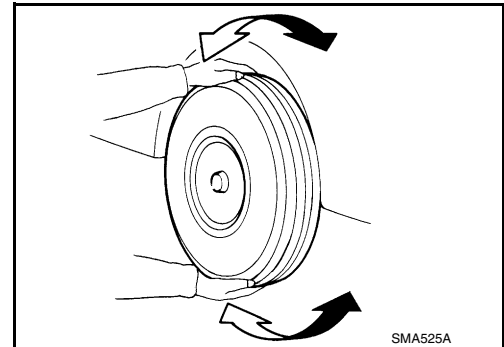

- Check shock absorber for oil leakage and other damage.
- Check suspension ball joint for grease leakage and ball joint dust cover for cracks and other damage.

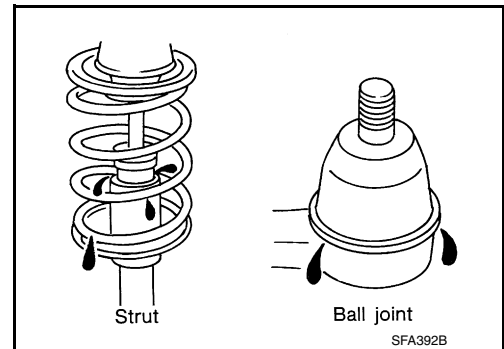

Front Wheel Alignment

INFOID:000000009885596

PRELIMINARY INSPECTION

WARNING:

Always adjust the alignment with the vehicle on a flat surface.

NOTE:

If alignment is out of specification, inspect and replace any damaged or worn suspension parts before making any adjustments.

1. Check and adjust the wheel alignment with the vehicle under unladen conditions. "Unladen conditions" means that the fuel, coolant, and lubricant are full; and that the spare tire, jack, hand tools and mats are in their designated positions.
2. Check the tires for incorrect air pressure and excessive wear.
3. Check the wheels for run out and damage. Refer to [WT-47, "Inspection"](#).
4. Check the wheel bearing axial end play. Refer to [FAX-5, "On-Vehicle Inspection and Service"](#).
5. Check the shock absorbers for leaks or damage.
6. Check each mounting point of the suspension components for any excessive looseness or damage.
7. Check each link, arm, and the rear suspension member for any damage.
8. Check the vehicle height. Refer to [FSU-23, "Wheelarch Height \(Unladen*1\)"](#).

GENERAL INFORMATION AND RECOMMENDATIONS

1. A Four-Wheel Thrust Alignment should be performed.
 - This type of alignment is recommended for any NISSAN vehicle.
 - The four-wheel "thrust" process helps ensure that the vehicle is properly aligned and the steering wheel is centered.
 - The alignment machine itself should be capable of accepting any NISSAN vehicle.
 - The alignment machine should be checked to ensure that it is level.
2. Make sure the alignment machine is properly calibrated.

ON-VEHICLE SERVICE

< PERIODIC MAINTENANCE >

- Your alignment machine should be regularly calibrated in order to give correct information.
- Check with the manufacturer of your specific alignment machine for their recommended Service/Calibration Schedule.

THE ALIGNMENT PROCESS

IMPORTANT: Use only the alignment specifications listed in this Service Manual. Refer to [FSU-22, "Wheel Alignment \(Unladen*1\)"](#).

1. When displaying the alignment settings, many alignment machines use "indicators": (Green/red, plus or minus, Go/No Go). **Do NOT use these indicators.**
 - The alignment specifications programmed into your alignment machine that operate these indicators may not be correct.
 - This may result in an ERROR.
2. Most camera-type alignment machines are equipped with both "Rolling Compensation" method and optional "Jacking Compensation" method to "compensate" the alignment targets or head units. "Rolling Compensation" is the preferred method.
 - If using the "Rolling Compensation" method, after installing the alignment targets or head units, push or pull on the rear wheel to move the vehicle. Do not push or pull on the vehicle body.
 - If using the "Jacking Compensation" method, after installing the alignment targets or head units, raise the vehicle and rotate the wheels 1/2 turn both ways.

NOTE:

- Do not use the "Rolling Compensation" method if you are using sensor-type alignment equipment.
- Follow all instructions in the alignment machine you are using for more information.

CAMBER AND CASTER

1. Measure camber and caster of both the right and left wheels and adjust as necessary to specification.

Camber and caster : Refer to [FSU-22, "Wheel Alignment \(Unladen*1\)"](#).

NOTE:

Some vehicles may be equipped with straight (non-adjustable) lower link bolts and washers. In order to adjust camber and caster on these vehicles, first replace the lower link bolts and washers with adjustable (cam) bolts and washers.

2. If outside of the specified value, adjust camber and caster using the cam bolts (1) in the front lower link (2).

CAUTION:

After adjusting the camber and caster check the toe-in.

NOTE:

Camber changes about 3' (0.05°) with each graduation of one cam bolt (1). Refer to table below for examples of lower link cam bolt (1) effect on camber and caster.

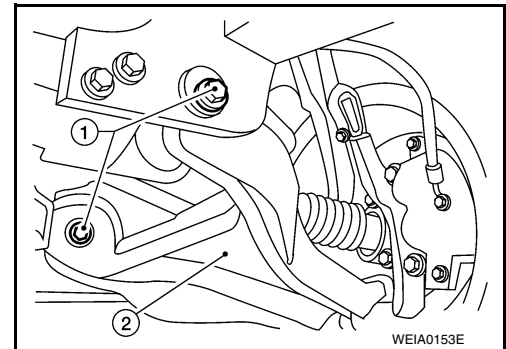

Rear cam bolt	1 In	1 Out	1 In	1 Out	0	0	1 In	1 Out
Front cam bolt	1 Out	1 In	1 In	1 Out	1 In	1 Out	0	0
Camber Degree minute (Decimal degree)	0 (0)	0 (0)	7' (0.12°)	- 7' (-0.12°)	3' (0.05°)	- 3' (-0.05°)	3' (0.05°)	- 3' (-0.05°)
Caster Degree minute (Decimal degree)	- 14' (-0.23°)	14' (0.23°)	0 (0)	0 (0)	7' (0.12°)	- 7' (-0.12°)	- 7' (-0.12°)	7' (0.12°)

3. Tighten the cam bolt nuts to specification. Refer to [FSU-10, "Exploded View"](#).

TOE-IN

WARNING:

ON-VEHICLE SERVICE

< PERIODIC MAINTENANCE >

- Always perform the following procedure on a flat surface.
 - Make sure that no person is in front of the vehicle before pushing it.
1. Bounce the front of vehicle up and down to stabilize the vehicle height (posture).
 2. Push the vehicle straight ahead about 5 m (16 ft).
 3. Put a mark on base line of the tread (rear side) of both front tires at the same height as hub center as shown. These marks are measuring points.

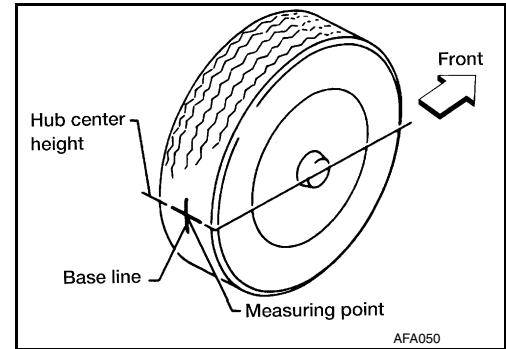

4. Measure the distance (A) on the rear side of the front tires as shown.
5. Push the vehicle slowly ahead to rotate the wheels 180° degrees (1/2 a turn).
CAUTION:
If the wheels have rotated more than 180° (1/2 turn), start this procedure again from the beginning. Never push the vehicle backward.
6. Measure the distance (B) on the front side of the front tires at the same marks as shown. Total toe-in is calculated as (A - B).

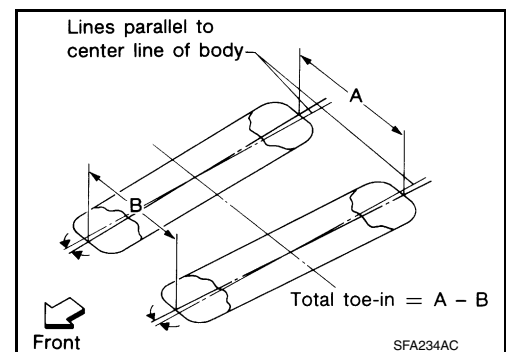

Total toe-in : Refer to [FSU-22, "Wheel Alignment \(Unladen*1\)"](#).

7. Adjust the toe-in by varying the length of the steering outer socket.
 - a. Loosen the outer tie-rod lock nuts.
 - b. Adjust the toe-in by screwing the outer tie-rods in or out.

Standard length (L) : Refer to [ST-31, "Steering Outer Socket and Steering Inner Socket"](#).

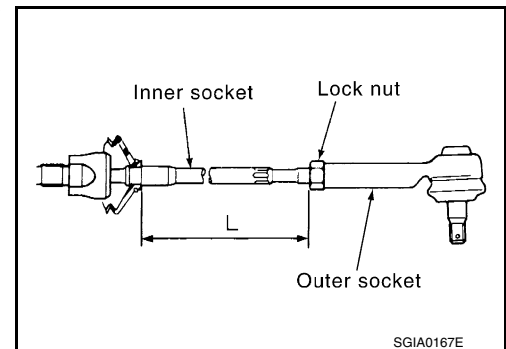

- c. Tighten the outer tie-rod lock nuts to specification.

Lock nut : Refer to [ST-24, "Disassembly and Assembly"](#).

FRONT WHEEL TURNING ANGLE

NOTE:

Check front wheel turning angle after the toe-in inspection.

1. Place front wheels on turning radius gauges in straight ahead position and rear wheels on stands so that vehicle can be level. Check the maximum inner and outer wheel turning angles for LH and RH road wheels.
2. Start engine and run at idle, turn steering wheel all the way right and left, measure the turning angle.

Wheel turning angle (full turn) : Refer to [FSU-22, "Wheel Alignment \(Unladen*1\)"](#).

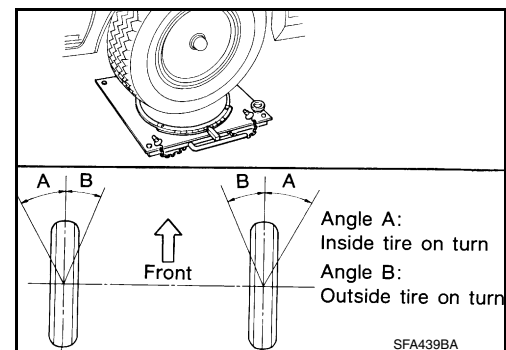

ON-VEHICLE SERVICE

< PERIODIC MAINTENANCE >

- Any turning angles are not adjustable. If any of steering angles are out of the specification, check if the following parts are worn or damaged:
 - Steering gear
 - Steering column
 - Front suspension components
- If found that they are worn or damaged, replace them with new ones.

KNUCKLE

< PERIODIC MAINTENANCE >

KNUCKLE

On-Vehicle Inspection and Service

INFOID:0000000988597

Make sure the mounting conditions (looseness, backlash) of each component and component status (wear, damage) are within specifications. Refer to [FSU-23. "Ball Joint"](#).

A
B
C
D
F
G
H
I
J
K
L
M
N
O
P

FSU

FRONT SUSPENSION ASSEMBLY

< REMOVAL AND INSTALLATION >

REMOVAL AND INSTALLATION

FRONT SUSPENSION ASSEMBLY

Exploded View

INFOID:000000009885598

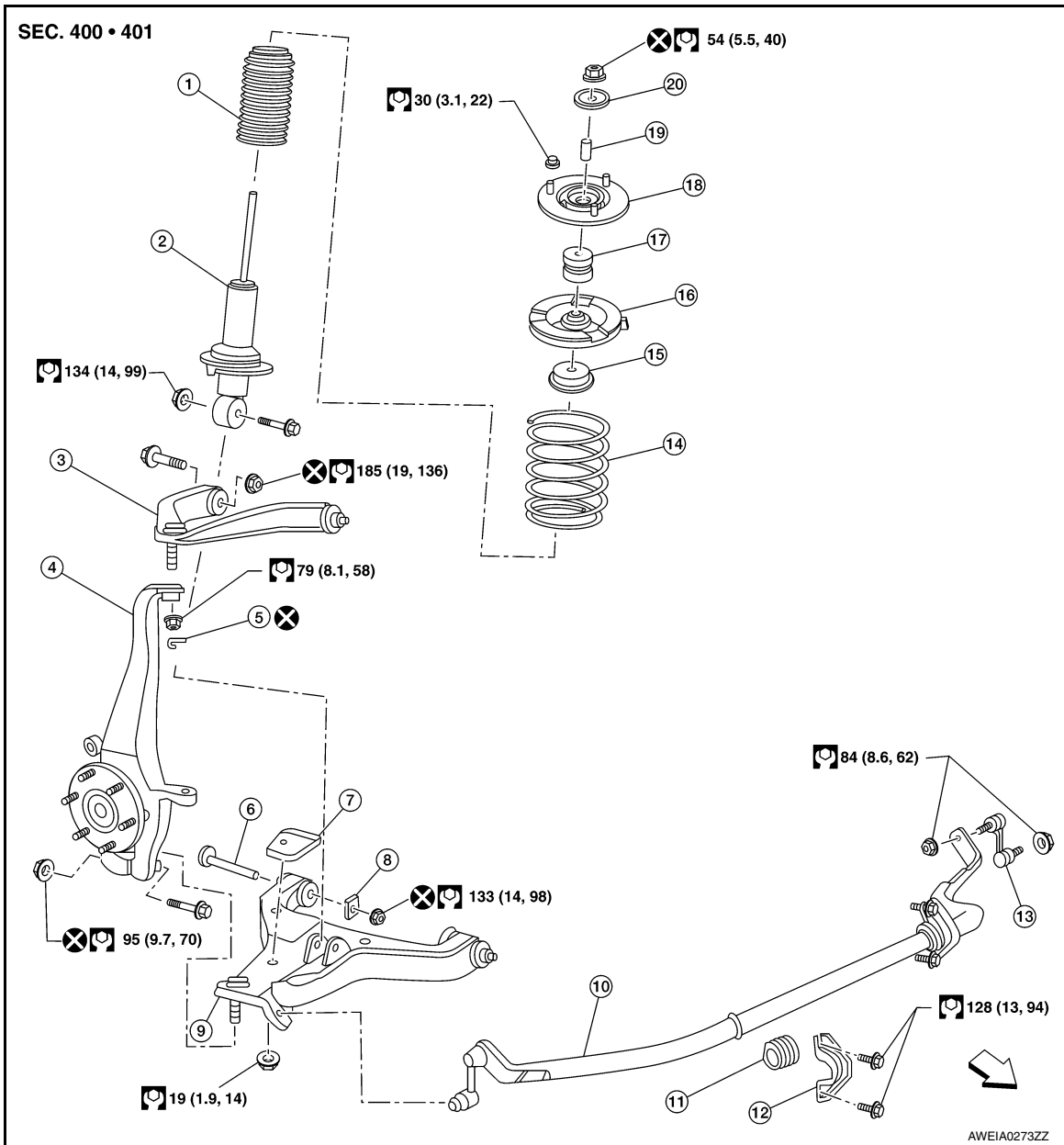

- | | | |
|-----------------------|----------------------------|---|
| 1. Dust cover | 2. Shock absorber | 3. Upper link |
| 4. Steering knuckle | 5. Cotter pin | 6. Lower link bolt/cam bolt (if equipped) |
| 7. Jounce bumper | 8. Washer | 9. Lower link |
| 10. Stabilizer bar | 11. Stabilizer bar bushing | 12. Stabilizer bar mounting bracket |
| 13. Connecting rod | 14. Coil spring | 15. Upper seat |
| 16. Upper spring seat | 17. Shock absorber bushing | 18. Shock absorber mounting insulator |
| 19. Spacer | 20. Washer | ⇐ Front |

COIL SPRING AND SHOCK ABSORBER

< REMOVAL AND INSTALLATION >

COIL SPRING AND SHOCK ABSORBER

Removal and Installation

INFOID:000000009885599

REMOVAL

1. Remove the wheel and tire using power tool. Refer to [WT-48. "Balancing Wheels"](#).
2. Turn steering knuckle out to gain enough clearance for removal.
3. Remove the shock absorber lower bolt using power tool.
4. Remove the three shock absorber upper nuts using power tool.
5. Remove the coil spring and shock absorber.

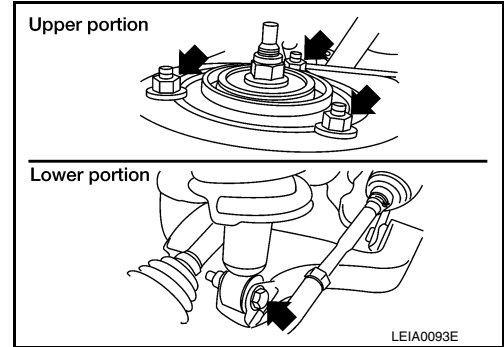

INSTALLATION

Installation is in the reverse order of removal.

- Position the coil spring and shock absorber (1) in the vehicle with the studs on the shock absorber mounting insulator (3) in line with the lower shock mount and the lower seat step (2). The lower seat step faces the outside of the vehicle.

⇐ : Front

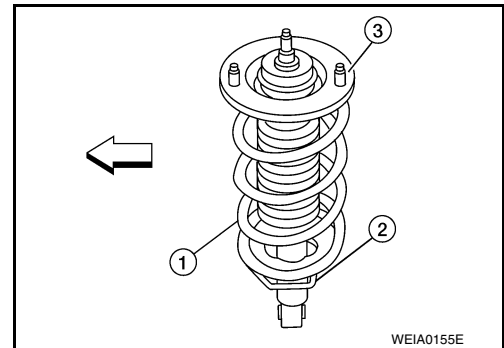

- Tighten all nuts and bolts to specification. Refer to [FSU-10. "Exploded View"](#).

Disposal

INFOID:000000009885600

1. Set shock absorber horizontally with the piston rod fully extended.
2. Drill 2 – 3 mm (0.08 – 0.12 in) hole at the position (●) from top as shown to release gas gradually.

CAUTION:

- Wear eye protection (safety glasses).
- Wear gloves.
- Be careful with metal chips or oil blown out by the compressed gas.

NOTE:

- Drill vertically in this direction (⇐).
- Directly to the outer tube avoiding brackets.
- The gas is clear, colorless, odorless, and harmless.

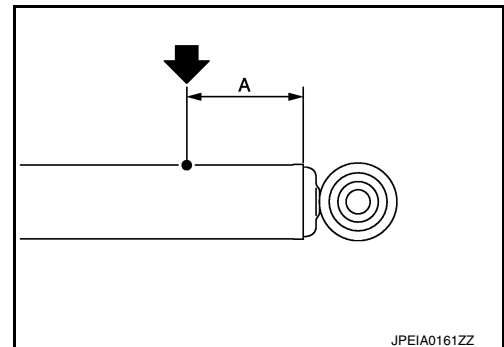

(A) : 20 – 30 mm (0.79 – 1.18 in)

3. Position the drilled hole downward and drain oil by moving the piston rod several times.

CAUTION:

Dispose of drained oil according to the law and local regulations.

STABILIZER BAR

< REMOVAL AND INSTALLATION >

STABILIZER BAR

Removal and Installation

INFOID:000000009885601

REMOVAL

1. If equipped, remove the engine under cover or the skid plate using power tool. Refer to [EXT-15, "Removal and Installation"](#).
2. Remove stabilizer bar mounting bracket bolts and connecting rod nuts using power tool, as shown.
3. Remove bushings from stabilizer bar.

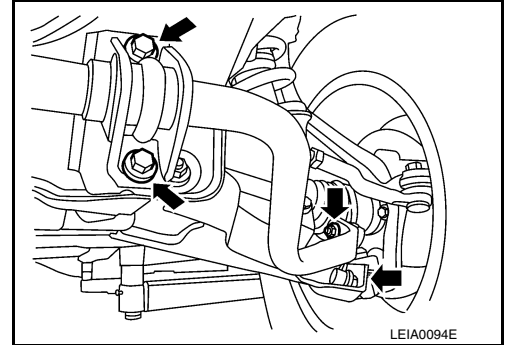

INSPECTION AFTER REMOVAL

- Check stabilizer bar for twist and deformation. Replace if necessary.
- Check rubber bushing for cracks, wear and deterioration. Replace if necessary.

INSTALLATION

Installation is in the reverse order of removal.

NOTE:

Be sure the stabilizer bar mounting brackets are centered between the 2 stabilizer bar retention collars.

- Tighten all nuts and bolts to specification. Refer to [FSU-10, "Exploded View"](#).

UPPER LINK

< REMOVAL AND INSTALLATION >

UPPER LINK

Removal and Installation

INFOID:000000009885602

REMOVAL

1. Remove the wheel and tire using power tool. Refer to [WT-48. "Balancing Wheels"](#).
2. Support the lower link with a jack.
3. Remove the fender protector to access the upper link. Refer to [EXT-24. "Removal and Installation"](#).
4. Remove the cotter pin and the nut from upper link ball joint. Discard the cotter pin.
5. Separate the upper link ball joint stud from the steering knuckle using Tool.

Tool number : **ST29020001 (J-24319-01)**

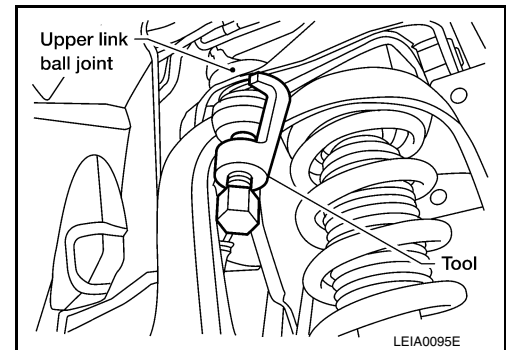

6. Remove the upper link bolts and nuts. Remove the upper link.

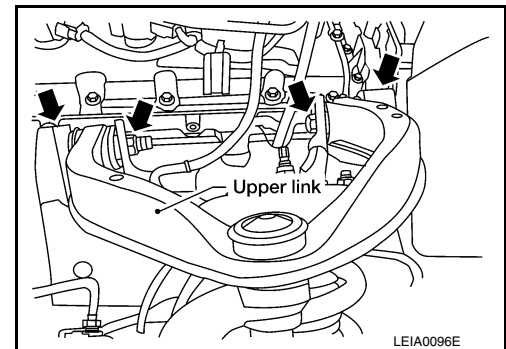

INSPECTION AFTER REMOVAL

Upper Link

Check for deformation and cracks. Replace if necessary.

Upper Link Ball Joint

Check for distortion and damage. Replace if necessary.

INSTALLATION

Installation is in the reverse order of removal.

CAUTION:

Do not reuse the upper link ball joint cotter pin.

- Tighten all nuts and bolts to specification. Refer to [FSU-10. "Exploded View"](#).

Inspection

INFOID:000000009885603

- Check ball joint for grease leakage. Check dust cover for damage.
- Check the ball joint for excessive play. Replace the upper or lower link assembly if any of the following exists:
 - Ball joint stud is worn.
 - Ball joint is hard to swing.
 - Ball joint play in axial directions or end play is excessive.

NOTE:

Before checking the axial forces and end play, turn the lower ball joint at least 10 revolutions so that the ball joint is properly broken in.

UPPER LINK

< REMOVAL AND INSTALLATION >

Measure the ball joint swinging force, turning force, and vertical end play using a suitable tool.

- Measure at the cotter pin hole for upper ball joint as shown.
- Measure at the groove for lower ball joint as shown.

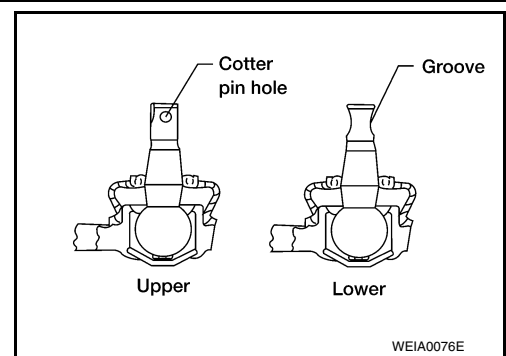

Swinging force (A)

Upper ball joint : Refer to [FSU-23, "Ball Joint"](#).

Lower ball joint : Refer to [FSU-23, "Ball Joint"](#).

Turning torque (B) : Refer to [FSU-23, "Ball Joint"](#).

Vertical end play (C) : Refer to [FSU-23, "Ball Joint"](#).

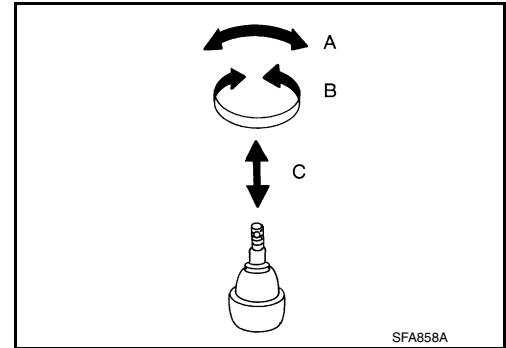

LOWER LINK

< REMOVAL AND INSTALLATION >

LOWER LINK

Removal and Installation

INFOID:000000009885604

REMOVAL

1. Remove the wheel and tire using power tool. Refer to [WT-48. "Balancing Wheels"](#).
2. Remove the lower shock absorber bolt.
3. Remove the stabilizer bar connecting rod lower nut using power tool. Separate connecting rod from lower link. Refer to [FSU-12. "Removal and Installation"](#).
4. Remove the drive shaft (if equipped). Refer to [FAX-8. "Removal and Installation"](#).
5. Remove the pinch bolt and nut from the steering knuckle using power tool. Separate the lower link ball joint from the steering knuckle.

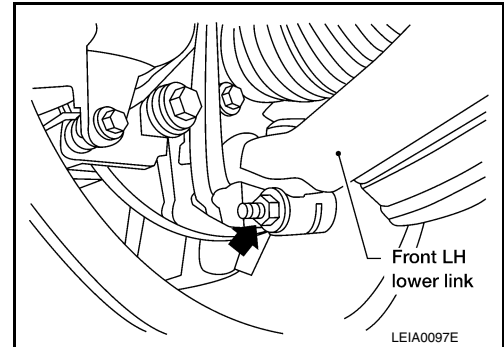

6. Remove the lower link bolts/cam bolts (if equipped) (1) and nuts. Remove the lower link (2).

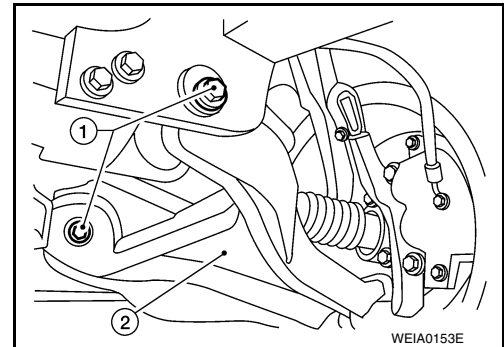

INSPECTION AFTER REMOVAL

Lower Link

Check for deformation and cracks. Replace if necessary.

Lower Link Bushing

Check for distortion and damage. Replace if necessary.

INSTALLATION

Installation is in the reverse order of removal.

CAUTION:

- Do not reuse the upper link ball joint cotter pin.
- Do not reuse the lower link ball joint nut.
- Do not reuse the lower link nuts.

NOTE:

Some vehicles may be equipped with straight (non-adjustable) lower link bolts and washers. In order to adjust camber and caster on these vehicles, replace the lower link bolts and washers with cam (adjustable) bolts and washers.

- Tighten all nuts and bolts to specification. Refer to [FSU-10. "Exploded View"](#).
- Check the wheel alignment. Refer to [FSU-5. "Front Wheel Alignment"](#).
- Adjust the neutral position of the steering angle sensor. Refer to [BRC-8. "ADJUSTMENT OF STEERING ANGLE SENSOR NEUTRAL POSITION : Special Repair Requirement"](#).

Inspection

INFOID:000000009885605

- Check ball joint for grease leakage. Check dust cover for damage.

LOWER LINK

< REMOVAL AND INSTALLATION >

- Check the ball joint for excessive play. Replace the upper or lower link assembly if any of the following exists:
 - Ball joint stud is worn.
 - Ball joint is hard to swing.
 - Ball joint play in axial directions or end play is excessive.

NOTE:

Before checking the axial forces and end play, turn the lower ball joint at least 10 revolutions so that the ball joint is properly broken in.

Measure the ball joint swinging force, turning force, and vertical end play using a suitable tool.

- Measure at the cotter pin hole for upper ball joint as shown.
- Measure at the groove for lower ball joint as shown.

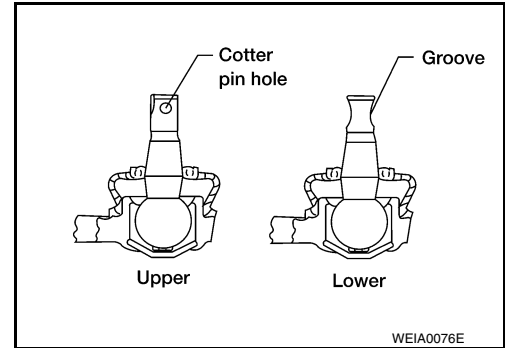

Swinging force (A)

Upper ball joint

: Refer to [FSU-23, "Ball Joint"](#).

Lower ball joint

: Refer to [FSU-23, "Ball Joint"](#).

Turning torque (B)

: Refer to [FSU-23, "Ball Joint"](#).

Vertical end play (C)

: Refer to [FSU-23, "Ball Joint"](#).

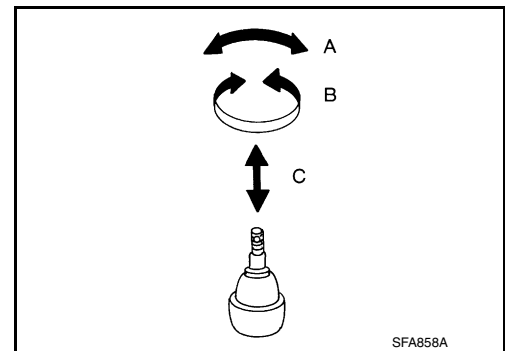

UPPER BALL JOINT AND LOWER BALL JOINT

< REMOVAL AND INSTALLATION >

UPPER BALL JOINT AND LOWER BALL JOINT

Removal and Installation

INFOID:000000009885606

The ball joints are part of the upper and lower links. Refer to [FSU-13. "Removal and Installation"](#) (upper link), [FSU-15. "Removal and Installation"](#) (lower link).

A
B
C
D
F
G
H
I
J
K
L
M
N
O
P

FSU

KNUCKLE

< REMOVAL AND INSTALLATION >

KNUCKLE

Removal and Installation

INFOID:00000009885607

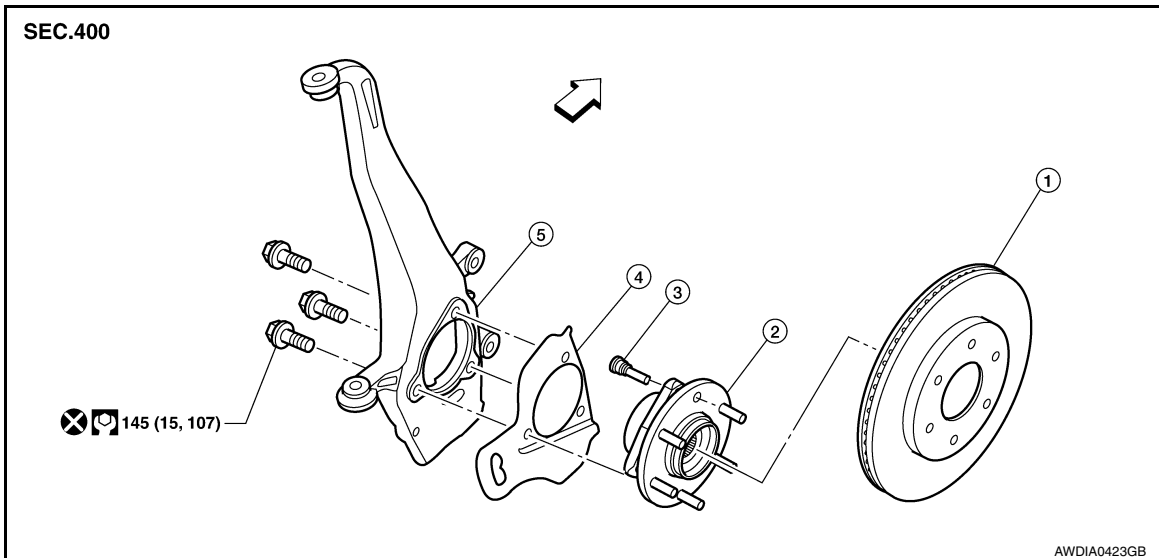

- | | | |
|-----------------|-----------------------------------|---------------|
| 1. Disc rotor | 2. Wheel hub and bearing assembly | 3. Wheel stud |
| 4. Splash guard | 5. Steering knuckle | ⇐ Front |

REMOVAL

1. Remove the wheel and tire using power tool. Refer to [WT-48, "Balancing Wheels"](#).
2. Disconnect wheel sensor harness connector. Do not remove the wheel sensor from the wheel hub and bearing assembly for this procedure.
3. Remove the wheel hub and bearing assembly. Refer to [FAX-6, "Removal and Installation"](#).
4. Remove the steering outer socket from the steering knuckle using Tool.

CAUTION:

- Be careful to not damage the ball joint boot.
- Temporarily tighten the nut to prevent damage to the threads and to prevent Tool from coming off.

Tool number : HT72520000 (J-25730-A)

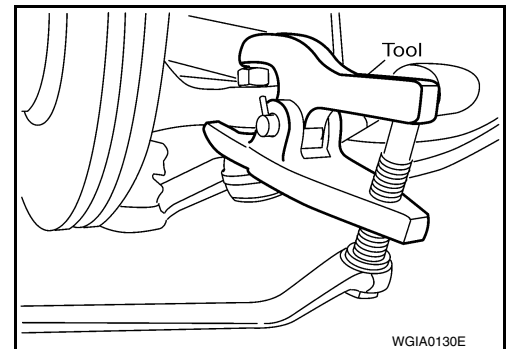

5. Remove the cotter pin and the nut from the upper link ball joint and discard the cotter pin.
6. Separate the upper link ball joint from the steering knuckle using Tool.

Tool number : ST29020001 (J-24319-01)

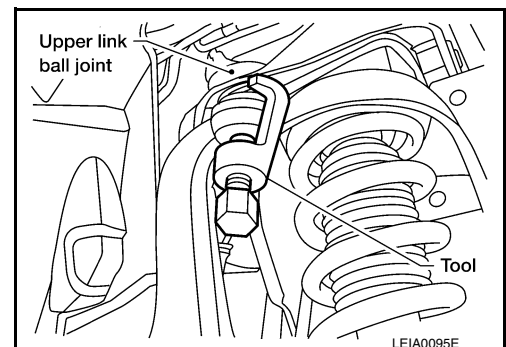

7. Remove the stabilizer bar connecting rod lower nut using power tool. Separate the connecting rod from the lower link. Refer to [FSU-12, "Removal and Installation"](#).

KNUCKLE

< REMOVAL AND INSTALLATION >

8. Remove the pinch bolt and nut from the steering knuckle using power tool. Separate the lower link ball joint from the steering knuckle.

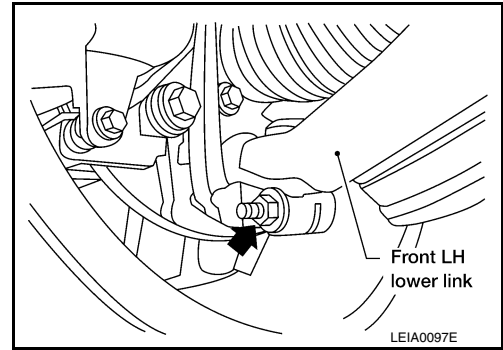

9. Remove the steering knuckle from the vehicle.

INSPECTION AFTER REMOVAL

- Check for deformity, cracks and damage on each part, replace if necessary.
- Perform ball joint inspection. Refer to [FSU-13. "Inspection"](#).

INSTALLATION

Installation is in the reverse order of removal.

CAUTION:

- **Do not reuse the lower link ball joint nut.**
- **Do not reuse the upper link ball joint cotter pin.**
- Tighten all nuts and bolts to specification. Refer to [FSU-10. "Exploded View"](#).
- When installing disc rotor on wheel hub and bearing assembly, align the marks.
- Check the wheel alignment. Refer to [FSU-5. "Front Wheel Alignment"](#).
- Adjust the neutral position of the steering angle sensor. Refer to [BRC-8. "ADJUSTMENT OF STEERING ANGLE SENSOR NEUTRAL POSITION : Special Repair Requirement"](#).

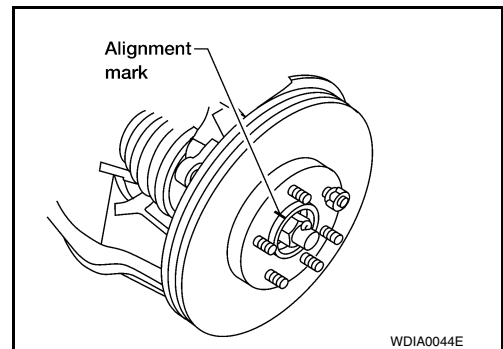

A
B
C
D

FSU

F
G
H
I
J
K
L
M
N
O
P

COIL SPRING AND SHOCK ABSORBER

< UNIT DISASSEMBLY AND ASSEMBLY >

UNIT DISASSEMBLY AND ASSEMBLY

COIL SPRING AND SHOCK ABSORBER

Disassembly and Assembly

INFOID:000000009885608

DISASSEMBLY

1. Set the coil spring and shock absorber in a vise.

CAUTION:

Do not remove the piston rod lock nut at this time.

2. Use a suitable bar to prevent the shock absorber mounting insulator from turning.
3. Loosen (without removing) the piston rod lock nut as shown.
4. Compress the coil spring using spring compressors (commercial service tools) until the shock absorber mounting insulator can be turned by hand.

WARNING:

Make sure that the pawls of the spring compressors (commercial service tools) are firmly hooked on the coil spring. The spring compressors (commercial service tools) must be tightened alternately and evenly so as not to tilt the coil spring.

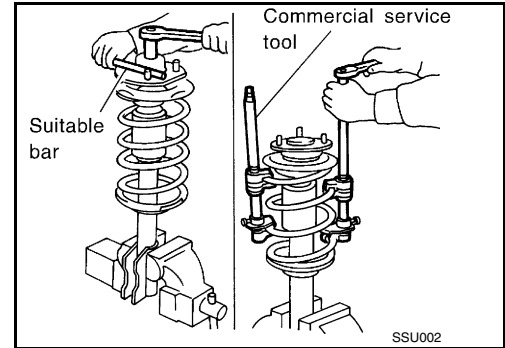

5. Remove the piston rod lock nut.
6. Remove the washer, the spacer, the shock absorber mounting insulator, the shock absorber bushing, and the upper spring seat.
7. Remove the dust cover and the upper seat.
8. Gradually release the spring compressors (commercial service tools) and remove the coil spring.

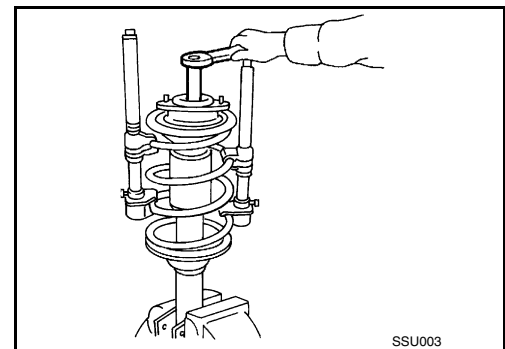

INSPECTION AFTER DISASSEMBLY

Shock Absorber

- Check the shock absorber for smooth operation through a full stroke, both compression and extension.
- Check the shock absorber for oil leakage on welded or gland packing portions.
- Check the piston rod for cracks, deformation or other damage and replace if necessary.

Mounting Insulator and Rubber Parts

Check the cemented rubber-to-metal portion for separation or cracks. Check rubber parts for deterioration and replace if necessary.

Coil Spring

- Check for cracks, deformation or other damage and replace if necessary.
- Check the free spring height.

Front spring free height

2WD : Refer to [FSU-22, "Spring Free Height"](#).

4WD : Refer to [FSU-22, "Spring Free Height"](#).

ASSEMBLY

1. Compress the coil spring using spring compressors (commercial service tools).

WARNING:

Make sure that the pawls of the spring compressors (commercial service tools) are firmly hooked on the coil spring. The spring compressors (commercial service tools) must be tightened alternately and evenly so as not to tilt the coil spring.

2. Install the coil spring to the shock absorber.

COIL SPRING AND SHOCK ABSORBER

< UNIT DISASSEMBLY AND ASSEMBLY >

3. Install the dust cover and the upper seat.
4. Install the upper spring seat, the shock absorber bushing, the shock absorber mounting insulator, the spacer, and the washer. Temporarily install, but do not tighten, the piston rod lock nut.

CAUTION:

Do not reuse the piston rod lock nut.

5. Position the coil spring lower end (2) and upper end (3) as shown.

(1) : Shock absorber mounting insulator

← : Flat tail

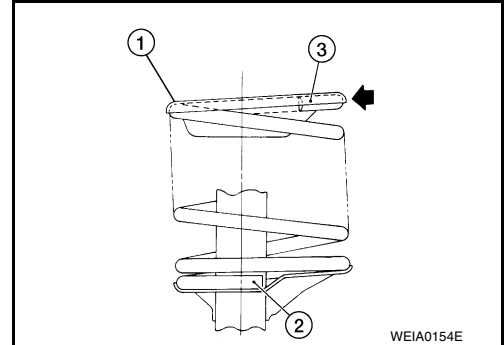

6. Position the shock absorber mounting insulator (3) with the studs in line with the lower shock mount and the lower seat step (2). The lower seat step faces the outside of the vehicle.

← : Front

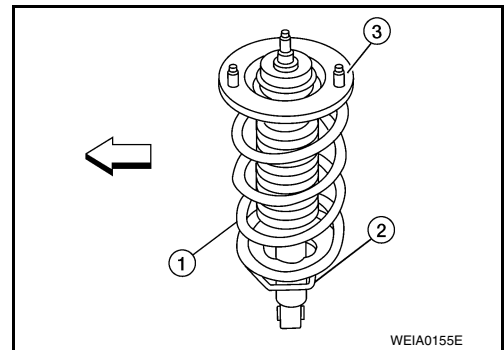

7. Gradually release the spring compressors (commercial service tools).
8. Tighten the piston rod lock nut to specification. Refer to [FSU-10, "Exploded View"](#).
9. Remove the coil spring and shock absorber from the vise.

A
B
C
D
FSU
F
G
H
I
J
K
L
M
N
O
P

SERVICE DATA AND SPECIFICATIONS (SDS)

< SERVICE DATA AND SPECIFICATIONS (SDS)

SERVICE DATA AND SPECIFICATIONS (SDS)

SERVICE DATA AND SPECIFICATIONS (SDS)

General Specification (Front)

INFOID:000000009885609

Suspension type	Independent double wishbone coil over shock
Shock absorber type	Double-acting hydraulic
Stabilizer	Standard equipment

Spring Free Height

INFOID:000000009885610

2WD	325.5 ± 3 mm (12.8 ± 0.1 in)
4WD	335.0 ± 3 mm (13.2 ± 0.1 in)

Wheel Alignment (Unladen*1)

INFOID:000000009885611

Drive type		2WD	4WD
Camber *6 Degree minute (decimal degree)	Minimum	-0° 57' (-0.95°)	-0° 27' (-0.45°)
	Nominal	-0° 12' (-0.20°)	0° 18' (0.30°)
	Maximum	0° 33' (0.55°)	1° 03' (1.05°)
	Cross camber	0° 45' (0.75°) or less	
Caster *6 Degree minute (decimal degree)	Minimum	2° 15' (2.25°)	1° 27' (1.45°)
	Nominal	3° 0' (3.00°)	2° 12' (2.20°)
	Maximum	3° 45' (3.75°)	2° 57' (2.95°)
	Cross caster	0° 45' (0.75°) or less	
Kingpin inclination (reference only) Degree minute (decimal degree)		13° 33' (13.55°)	13° 0' (13.00°)

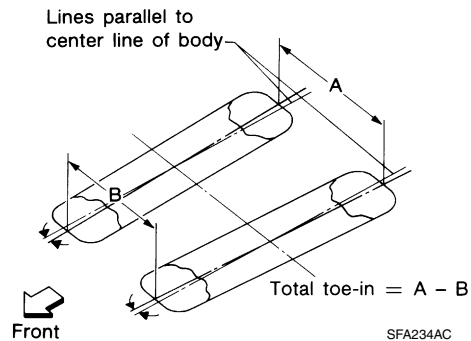

Total toe-in	Total toe-in Distance (A - B)	Minimum	In 0.5 mm (In 0.02 in)
		Nominal	In 2.5 mm (In 0.10 in)
		Maximum	In 4.5 mm (In 0.17 in)
	Total toe-in Angle Degree minute (decimal degree)	Minimum	In 0° 0' 36" (In 0.01°)
		Nominal	In 0° 10' 12" (In 0.17°)
		Maximum	In 0° 19' 48" (In 0.33°)
Wheel turning angle (full turn)	Inside Degree minute (decimal degree)	34° 30' - 38° 30' *2 (34.50° - 38.50°)	34° 56' - 38° 56' *4 (34.93° - 38.93°)
	Outside Degree minute (decimal degree)	30° 58' - 34° 58' *3 (30.97° - 34.97°)	31° 01' - 35° 01' *5 (31.02° - 35.02°)

*1: Fuel, radiator coolant and engine oil full. Spare tire, jack, hand tools and mats in designated positions.

SERVICE DATA AND SPECIFICATIONS (SDS)

< SERVICE DATA AND SPECIFICATIONS (SDS)

*2: Target value 37° 30' (37.50°)

*3: Target value 33° 58' (33.97°)

*4: Target value 37° 56' (37.93°)

*5: Target value 34° 01' (34.02°)

*6: Some vehicles may be equipped with straight (non-adjustable) lower link bolts and washers. In order to adjust camber and caster on these vehicles, first replace the lower link bolts and washers with adjustable (cam) bolts and washers.

Ball Joint

INFOID:000000009885612

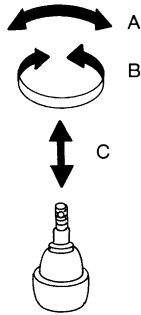

SFA858A

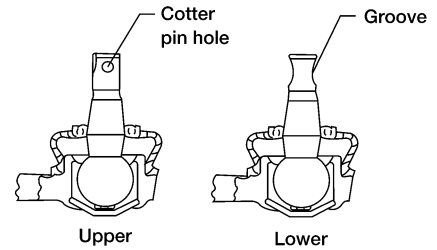

WEIA0076E

Swinging force (A)	Upper ball joint	8.1 – 103.2 N (0.8 – 10.5 kg-f, 1.8 – 23.2 lb-f) *1
	Lower ball joint	11.4 – 145.5 N (1.1 – 14.8 kg-f, 2.5 – 32.7 lb-f) *2
Turning torque (B)		0.5 – 6.4 N·m (0.05 – 0.65 kg-m, 4 – 57 in-lb)
Vertical end play (C)		0 mm (0 in)

*1 Measure at cotter pin hole

*2 Measure at groove

Wheelarch Height (Unladen*1)

INFOID:000000009885613

Unit: mm (in)

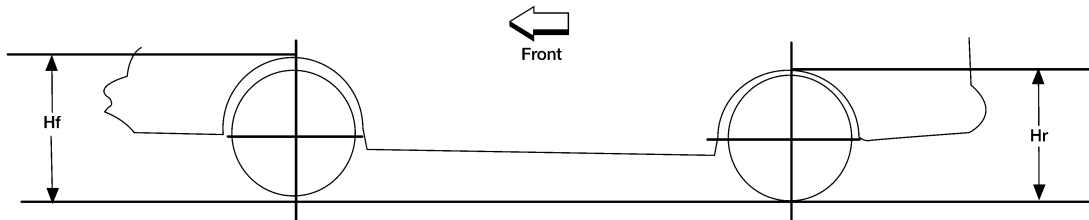

LEIA0085E

Drive type	2WD				4WD*2				4WD*3				
	Short		Long		Short		Long		Short		Long		
Wheel base	King Cab	Crew Cab	King Cab	Crew Cab	King Cab	Crew Cab	King Cab	Crew Cab	King Cab	Crew Cab	King Cab	Crew Cab	
Body	King Cab	Crew Cab	King Cab	Crew Cab	King Cab	Crew Cab	King Cab	Crew Cab	King Cab	Crew Cab	King Cab	Crew Cab	
Front wheel arch height (Hf)	P265/70R18	912 (35.91)	914 (35.98)	912 (35.91)	914 (35.98)	949 (37.36)	951 (37.44)	949 (37.36)	951 (37.44)	949 (37.36)	951 (37.44)	949 (37.36)	951 (37.44)
	P275/70R18	922 (36.30)	925 (36.42)	922 (36.30)	925 (36.42)	960 (37.80)	962 (37.87)	959 (37.76)	962 (37.87)	960 (37.80)	962 (37.87)	959 (37.76)	962 (37.87)
	P275/60R20	917 (36.10)	919 (36.18)	917 (36.10)	920 (36.22)	955 (37.60)	957 (37.68)	954 (37.56)	957 (37.68)	955 (37.60)	957 (37.68)	954 (37.56)	957 (37.68)

SERVICE DATA AND SPECIFICATIONS (SDS)

< SERVICE DATA AND SPECIFICATIONS (SDS)

Rear wheel arch height (Hr)	P265/ 70R18	952 (37.48)	954 (37.56)	950 (37.40)	951 (37.44)	991 (39.02)	994 (39.13)	989 (38.94)	991 (39.02)	991 (39.02)	993 (39.09)	989 (38.94)	991 (39.02)
	P275/ 70R18	962 (37.87)	965 (37.99)	960 (37.80)	962 (37.87)	1002 (39.45)	1004 (39.53)	1000 (39.37)	1002 (39.45)	1001 (39.41)	1004 (39.53)	1000 (39.37)	1002 (39.45)
	P275/ 60R20	957 (37.68)	959 (37.76)	955 (37.60)	956 (37.64)	996 (39.21)	999 (39.33)	995 (39.17)	996 (39.21)	996 (39.21)	998 (39.29)	995 (39.17)	996 (39.21)

*1: Fuel, radiator coolant and engine oil full. Spare tire, jack, hand tools and mats in designated positions.

*2: Without tow package.

*3: With tow package.