

SECTION **SB**
SEAT BELT

A
B
C
D
E
F
G
SB
I
J
K
L
M
N
O
P

CONTENTS

PRECAUTION	2	For Side and Rollover Collision	9
PRECAUTIONS	2	REMOVAL AND INSTALLATION	13
Precaution for Supplemental Restraint System (SRS) "AIR BAG" and "SEAT BELT PRE-TEN- SIONER"	2	SEAT BELTS	13
Precaution for Seat Belt Service	2	Removal and Installation of Front Seat Belt	13
BASIC INSPECTION	4	Removal and Installation of Rear Seat Belt	18
COMPONENT INSPECTION	4	LATCH (LOWER ANCHORS AND TETHER FOR CHILDREN) SYSTEM	20
Inspection	4	Removal and Installation	20
COLLISION DIAGNOSIS	7	TOP TETHER STRAP CHILD RESTRAINT	21
For Frontal Collision	7	Removal and Installation	21

PRECAUTIONS

< PRECAUTION >

PRECAUTION

PRECAUTIONS

Precaution for Supplemental Restraint System (SRS) "AIR BAG" and "SEAT BELT PRE-TENSIONER"

INFOID:000000011560937

The Supplemental Restraint System such as "AIR BAG" and "SEAT BELT PRE-TENSIONER", used along with a front seat belt, helps to reduce the risk or severity of injury to the driver and front passenger for certain types of collision. This system includes seat belt switch inputs and dual stage front air bag modules. The SRS system uses the seat belt switches to determine the front air bag deployment, and may only deploy one front air bag, depending on the severity of a collision and whether the front occupants are belted or unbelted. Information necessary to service the system safely is included in the SR and SB section of this Service Manual.

WARNING:

- To avoid rendering the SRS inoperative, which could increase the risk of personal injury or death in the event of a collision which would result in air bag inflation, all maintenance must be performed by an authorized NISSAN/INFINITI dealer.
- Improper maintenance, including incorrect removal and installation of the SRS, can lead to personal injury caused by unintentional activation of the system. For removal of Spiral Cable and Air Bag Module, see the SR section.
- Do not use electrical test equipment on any circuit related to the SRS unless instructed to in this Service Manual. SRS wiring harnesses can be identified by yellow and/or orange harnesses or harness connectors.

PRECAUTIONS WHEN USING POWER TOOLS (AIR OR ELECTRIC) AND HAMMERS

WARNING:

- When working near the Airbag Diagnosis Sensor Unit or other Airbag System sensors with the Ignition ON or engine running, DO NOT use air or electric power tools or strike near the sensor(s) with a hammer. Heavy vibration could activate the sensor(s) and deploy the air bag(s), possibly causing serious injury.
- When using air or electric power tools or hammers, always switch the Ignition OFF, disconnect the battery and wait at least three minutes before performing any service.

Precaution for Seat Belt Service

INFOID:000000011560938

CAUTION:

- Before removing the seat belt pre-tensioner assembly, turn the ignition switch OFF, disconnect both battery cables and wait at least 3 minutes.
- After replacing or reinstalling seat belt pre-tensioner assembly, or reconnecting seat belt pre-tensioner assembly connector, ensure entire SRS operates properly. Refer to [SRC-15, "SRS Operation Check"](#).
- Do not disassemble buckle or seat belt assembly.
- Do not reuse seat belt anchor bolts after removal. Replace with new ones.
- Replace anchor bolts if they are deformed or worn out.
- Never oil tongue and buckle.
- If any component of seat belt assembly is questionable, do not repair. Replace the whole seat belt assembly.
- If webbing is cut, frayed, or damaged, replace seat belt assembly.
- When replacing seat belt assembly, use a genuine NISSAN seat belt assembly.

AFTER A COLLISION

WARNING:

- Inspect all seat belt assemblies including retractors and attaching hardware after any collision.
- NISSAN recommends that all seat belt assemblies in use during a collision be replaced unless the collision was minor and the belts show no damage and continue to operate properly. Failure to do so could result in serious personal injury in an accident. Seat belt assemblies not in use during a collision should also be replaced if either damage or improper operation is noted. Seat belt pre-tensioner should be replaced even if the seat belts are not in use during a frontal collision in which the air bags are deployed.

Replace any seat belt assembly (including anchor bolts) if:

PRECAUTIONS

< PRECAUTION >

- The seat belt was in use at the time of a collision (except for minor collisions and the belts, retractors and buckles show no damage and continue to operate properly). A
- The seat belt was damaged in an accident. (i.e., torn webbing, bent retractor or guide, etc.) B
- The seat belt attaching point was damaged in an accident. Inspect the seat belt attaching area for damage or distortion and repair as necessary before installing a new seat belt assembly. C
- Anchor bolts are deformed or worn out.
- The seat belt pre-tensioner should be replaced even if the seat belts are not in use during the collision in which the air bags are deployed.

OCCUPANT CLASSIFICATION SYSTEM

- Replace occupant classification system control unit and passenger front seat cushion as an assembly. Refer to [SE-34. "Removal and Installation - Front Seat Assembly"](#). D

A
B
C
D
E
F
G
SB
I
J
K
L
M
N
O
P

SB

COMPONENT INSPECTION

< BASIC INSPECTION >

BASIC INSPECTION

COMPONENT INSPECTION

Inspection

INFOID:0000000011560939

AFTER A COLLISION

WARNING:

Inspect all seat belt assemblies including retractors and attaching hardware after any collision. NISSAN/INFINITI recommends that all seat belt assemblies in use during a collision be replaced unless the collision was minor and the belts show no damage and continue to operate properly. Failure to do so could result in serious personal injury in an accident. Seat belt assemblies not in use during a collision should also be replaced if either damage or improper operation is noted. Seat belt pretensioners should be replaced even if the seat belts are not in use during a frontal collision in which the air bags are deployed.

Replace any seat belt assembly (including anchor bolts) if:

- The seat belt was in use at the time of a collision (except for minor collisions and the belts, retractors and buckles show no damage and continue to operate properly).
- The seat belt was damaged in an accident (i.e. torn webbing, bent retractor or guide, etc.).
- The seat belt attaching point is damaged in an accident. Inspect the seat belt attaching area for damage or distortion and repair if necessary before installing a new seat belt assembly.
- Anchor bolts are deformed or worn out.
- The seat belt pre-tensioner should be replaced even if the seat belts are not in use during the collision in which the air bags are deployed.

PRELIMINARY CHECKS

1. Check the seat belt warning lamp for proper operation per the following:
 - a. Turn ignition switch ON. The seat belt warning lamp should illuminate.
 - b. Fasten driver seat belt. The seat belt warning lamp should turn OFF.
 2. If the air bag warning lamp is blinking, perform self-diagnosis with CONSULT and air bag warning lamp. Refer to [SRC-17. "Trouble Diagnosis without CONSULT"](#).
 3. Check that the seat belt retractor, seat belt anchor and buckle bolts are tightened firmly.
 4. Check the shoulder seat belt guide and shoulder belt height adjuster for front seats. Check that guide swivels freely and that webbing lays flat and does not bind in guide. Check that height adjuster operates properly and holds securely.
 5. Check retractor operation:
 - a. Fully extend the seat belt webbing and check for twists, tears or other damage.
 - b. Allow the seat belt to retract. Check that webbing returns smoothly and completely into the retractor. If the seat belt does not return smoothly, wipe the inside of the loops with a clean paper cloth. Dirt build-up in the loops of the upper anchors can cause the seat belts to retract slowly.
 - c. Fasten the seat belt. Check that seat belt returns smoothly and completely to the retractor. If the webbing does not return smoothly, the cause may be an accumulation of dust or dirt. Use the "SEAT BELT TAPE SET" and perform the following steps.
 - d. Inspect the front seat belt D-ring anchor
 1. Pull the seat belt out to a length of 500 mm (19.69 in) or more.
 2. Hold the seat belt at the center pillar webbing opening with a clip or other device.
 3. Pass a thin wire through the D-ring anchor webbing opening. Hold both ends of the wire and pull it tightly while moving it up and down several times along the webbing opening surface to remove dirt stuck there.
 4. Any dirt that cannot be removed with the wire can be removed by cleaning the opening with a clean cloth.
 5. Apply tape at the point where the webbing contacts the D-ring anchor webbing opening.
- NOTE:**
Apply the tape so that there is no slack or wrinkling.
6. Remove the clip holding the seat belt and check that the webbing returns smoothly.
 6. Repeat steps above if necessary to check the other seat belts.

COMPONENT INSPECTION

< BASIC INSPECTION >

SEAT BELT RETRACTOR ON-VEHICLE CHECK

Emergency Locking Retractors (ELR) and Automatic Locking Retractors (ALR)

NOTE:

All seat belt retractors are Emergency Locking Retractors (ELR) type. In an emergency (sudden stop) the retractor will lock and prevent the webbing from extending any further. All 3-point type seat belt retractors except the driver seat belt also have an Automatic Locking Retractors (ALR) mode. The ALR mode (also called child restraint mode) is used when installing child seats. The ALR mode is activated when the seat belt is fully extended. When the webbing is then retracted partially, the ALR mode automatically locks the seat belt in a specific position so the webbing cannot be extended any further. To cancel the ALR mode, allow the seat belt to fully wind back into the retractor.

Check the seat belt retractors with the following test(s) to determine if a retractor assembly is operating properly.

ELR Function Stationary Check

Grasp the shoulder webbing and pull forward quickly. The retractor should lock and prevent the belt from extending further.

ALR Function Stationary Check

1. Pull out the entire length of seat belt from retractor until a click is heard.
2. Retract the webbing partially. A clicking noise should be heard as the webbing retracts, indicating that the retractor is in the Automatic Locking Retractors (ALR) mode.
3. Grasp the seat belt and try to pull out the retractor. The webbing must lock and not extend any further. If it does not operate normally, replace the retractor assembly.
4. Allow the entire length of the webbing to retract to cancel the automatic locking mode.

ELR Function Moving Check

WARNING:

Perform the following test in a safe, open area clear of other vehicles and obstructions (for example, a large, empty parking lot). Road surface must be paved and dry. Never perform the following test on wet or gravel roads or on public streets and highways. This could result in an accident and serious personal injury. The driver and passenger must be prepared to brace themselves in the event that the retractor does not lock.

1. Fasten driver seat belt. Buckle a passenger into the seat for the belt that is to be tested.
2. Proceed to the designated safe area.
3. Drive the vehicle at approximately 16 km/h (10 mph). Notify any passengers of a pending sudden stop and the driver and passenger must be prepared to brace themselves in the event that the retractor does not lock. Apply brakes firmly and make a very hard stop.

During stopping, seat belts should lock and not be extended. If the seat belt retractor assembly does not lock, perform the retractor off-vehicle check.

FRONT SEAT BELT RETRACTOR OFF-VEHICLE CHECK

1. Remove the front seat belt retractor. Refer to [SB-13, "Removal and Installation of Front Seat Belt"](#).
2. Slowly pull out webbing while tilting the seat belt retractor forward from the mounted position without twisting the seat belt retractor as shown.

A : The webbing can be pulled out if the retractor is tilted 15° degree or less.

B : The webbing can not be pulled out if the retractor is tilted 35° degrees or more.

NOTE:

A and B show tilting angles.

⇐: Front

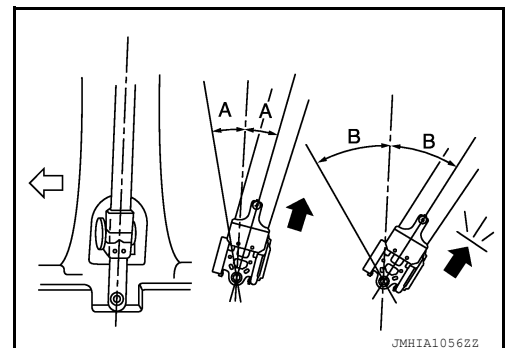

3. Replace the seat belt retractor if it does not operate within specifications.

REAR SEAT BELT OUTER RETRACTOR OFF-VEHICLE CHECK

COMPONENT INSPECTION

< BASIC INSPECTION >

1. Remove the rear seat belt retractor. Refer to [SB-18, "Removal and Installation of Rear Seat Belt"](#).
2. Slowly pull out webbing while tilting the seat belt retractor forward from the mounted position without twisting the seat belt retractor as shown.

A : The webbing can be pulled out if the retractor is tilted 15° degree or less.

B : The webbing can not be pulled out if the retractor is tilted 35° degrees or more.

NOTE:

A and B show tilting angles.

⇐: Front

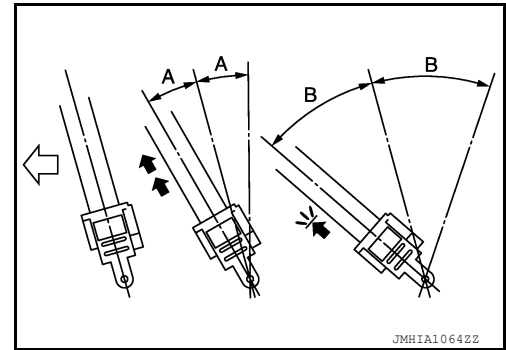

3. Replace the seat belt retractor if it does not operate within specifications.

REAR SEAT BELT CENTER RETRACTOR OFF-VEHICLE CHECK

1. Remove the rear seat belt center retractor. Refer to [SB-18, "Removal and Installation of Rear Seat Belt"](#).
2. Slowly pull out webbing while tilting the seat belt retractor forward from the mounted position without twisting the seat belt retractor as shown.

A : The webbing can be pulled out if the retractor is tilted 15° degree or less.

B : The webbing can not be pulled out if the retractor is tilted 35° degrees or more.

NOTE:

A and B show tilting angles.

⇐: Front

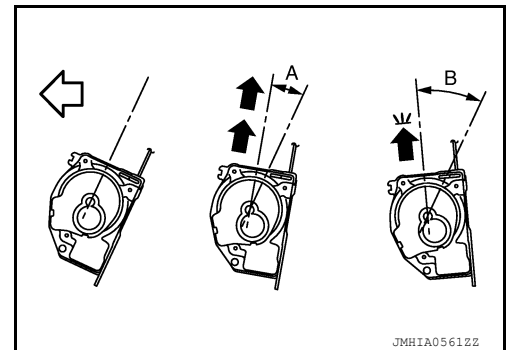

3. Replace the seat belt retractor if it does not operate within specifications.

COLLISION DIAGNOSIS

< BASIC INSPECTION >

COLLISION DIAGNOSIS

For Frontal Collision

INFOID:000000011560940

FOR FRONTAL COLLISION: When SRS is activated in a collision

CAUTION:

Due to varying models and option levels, not all parts listed in the chart below apply to all vehicles.

WORK PROCEDURE

1. Before performing any of the following steps, ensure that all vehicle body and structural repairs have been completed.
2. Replace the diagnosis sensor unit.
3. Remove the front air bag modules, crash zone sensor assembly, bracket and seat belt pre-tensioner assemblies.
4. Check the SRS components using the table below:
Replace any SRS components showing visible signs of damage. (dents, cracks and deformation, etc.)
5. Install new front air bag modules, crash zone sensor assembly, bracket and seat belt pre-tensioner assemblies.
6. Perform self-diagnosis using CONSULT or air bag warning lamp. Refer to [SRC-17, "Self-Diagnosis Function \(Without CONSULT\)"](#) for details.
Ensure entire SRS operates properly.
7. After the work is completed, perform self-diagnosis to check that no malfunction is detected. Refer to [SRC-15, "SRS Operation Check"](#).

SRS INSPECTION (FOR FRONTAL COLLISION)

Part	Inspection
Driver air bag module	If the driver air bag has deployed: REPLACE Install with new fasteners.
Front passenger air bag module (if equipped)	If the front passenger air bag has deployed: REPLACE Install with new fasteners.
Crash zone sensor	If any of the front air bags or seat belt pre-tensioners* have been activated: REPLACE the crash zone sensor and bracket with new fasteners. *: Confirm seat belt pre-tensioner activation using CONSULT only.
Seat belt pre-tensioner assemblies (All applicable locations: buckle, retractor, lap outer)	If either the driver or passenger seat belt pre-tensioner* has been activated: REPLACE all seat belt pre-tensioner assemblies with new fasteners. *: Confirm seat belt pre-tensioner activation using CONSULT only.
Diagnosis sensor unit	If any of the SRS components have been activated: REPLACE the diagnosis sensor unit. Install with new fasteners.
Steering wheel	<ol style="list-style-type: none"> 1. Visually check steering wheel for deformities. 2. Check harness (built into steering wheel) and connectors for damage, and terminals for deformities. 3. Install driver air bag module into the steering wheel to check fit and alignment with the wheel. 4. Check steering wheel for excessive free play. 5. If no damage is found, reinstall. 6. If damaged — REPLACE.
Spiral cable	If the driver front air bag has deployed: REPLACE the spiral cable.
Occupant classification system (Passenger seat)	<ol style="list-style-type: none"> 1. Remove passenger seat assembly. 2. Check control unit case for dents, cracks or deformities. 3. Check connectors and pressure sensor tube for damage, and terminals for deformities. 4. Check seat frame and cushion pan for dents or deformities. 5. If no damage is found, reinstall seat with new fasteners. 6. If damaged— REPLACE seat cushion assembly with new fasteners.

COLLISION DIAGNOSIS

< BASIC INSPECTION >

Part	Inspection
Harness and connectors	<ol style="list-style-type: none"> 1. Check connectors for poor connection, damage, and terminals for deformities. 2. Check harness for binding, chafing, cuts, or deformities. 3. If no damage is found, reinstall the harness and connectors. 4. If damaged — REPLACE the damaged harness. Do not attempt to repair, splice or modify any SRS harness.
Instrument panel assembly	If the passenger front air bag has deployed: REPLACE the instrument panel assembly. (integrated type)

FOR FRONTAL COLLISION: When SRS is not activated in a collision

CAUTION:

Due to varying models and option levels, not all parts listed in the chart below apply to all vehicles.

WORK PROCEDURE

1. Before performing any of the following steps, ensure that all vehicle body and structural repairs have been completed.
2. Check the SRS components using the table below:
Replace any SRS components showing visible signs of damage. (dents, cracks and deformation, etc.)
3. Perform self-diagnosis using CONSULT or air bag warning lamp. Refer to [SRC-17. "Self-Diagnosis Function \(Without CONSULT\)"](#) for details.
Ensure entire SRS operates properly.
4. After the work is completed, perform self-diagnosis to check that no malfunction is detected. Refer to [SRC-15. "SRS Operation Check"](#).

SRS INSPECTION (FOR FRONTAL COLLISION)

Part	Inspection
Driver air bag module	If the driver air bag has NOT been activated: <ol style="list-style-type: none"> 1. Remove driver air bag module. Check harness cover and connectors for damage, terminals for deformities, and harness for binding. 2. Install driver air bag module into the steering wheel to check fit and alignment with the wheel. 3. If no damage is found, reinstall with new fasteners. 4. If damaged — REPLACE. Install driver air bag modules with new fasteners.
Front passenger air bag module (if equipped)	If the front passenger air bag has NOT been activated: <ol style="list-style-type: none"> 1. Remove front passenger air bag module. Check harness cover and connectors for damage, terminals for deformities, and harness for binding. 2. Install front passenger air bag module into the instrument panel to check fit with the instrument panel. 3. If no damage is found, reinstall with new fasteners. 4. If damaged — REPLACE. Install front passenger air bag modules with new fasteners.
Crash zone sensor	If the front air bags or seat belt pre-tensioners have NOT been activated: <ol style="list-style-type: none"> 1. Remove the crash zone sensor. Check harness connectors for damage, terminals for deformities, and harness for binding. 2. Check for visible signs of damage (dents, cracks, deformation) of the crash zone sensor and bracket. 3. Install the crash zone sensor to check fit. 4. If no damage is found, reinstall with new fasteners. 5. If damaged — REPLACE the crash zone sensor and bracket with new fasteners.
Seat belt pre-tensioner assemblies (All applicable locations: buckle, retractor, lap outer)	If the pre-tensioners have NOT been activated: <ol style="list-style-type: none"> 1. Remove seat belt pre-tensioners. Check harness cover and connectors for damage, terminals for deformities, and harness for binding. 2. Check belts for damage and anchors for loose mounting. 3. Check retractor for smooth operation. 4. Check seat belt adjuster for damage. 5. Check for deformities of the center pillar inner. 6. If the center pillar inner has no damage, REPLACE the seat belt pre-tensioner assembly. 7. If no damage is found, reinstall seat belt pre-tensioner assembly. 8. If damaged —REPLACE. Install the seat belt pre-tensioners with new fasteners.

COLLISION DIAGNOSIS

< BASIC INSPECTION >

Part	Inspection
Diagnosis sensor unit	If none of the SRS components have been activated: <ol style="list-style-type: none"> 1. Check case for dents, cracks or deformities. 2. Check connectors for damage, and terminals for deformities. 3. If no damage is found, reinstall with new fasteners. 4. If damaged — REPLACE. Install diagnosis sensor unit with new fasteners.
Steering wheel	<ol style="list-style-type: none"> 1. Visually check steering wheel for deformities. 2. Check harness (built into steering wheel) and connectors for damage, and terminals for deformities. 3. Install driver air bag module into the steering wheel to check fit and alignment with the wheel. 4. Check steering wheel for excessive free play. 5. If no damage is found, reinstall. 6. If damaged — REPLACE.
Spiral cable	If the driver front air bag has not deployed: <ol style="list-style-type: none"> 1. Visually check spiral cable and combination switch for damage. 2. Check connectors and protective tape for damage. 3. Check steering wheel for noise, binding or heavy operation. 4. If no damage is found, reinstall. 5. If damaged — REPLACE.
Occupant classification system (Passenger seat)	<ol style="list-style-type: none"> 1. Remove passenger seat assembly. 2. Check control unit case for dents, cracks or deformities. 3. Check connectors and pressure sensor tube for damage, and terminals for deformities. 4. Check seat frame and cushion pan for dents or deformities. 5. If no damage is found, reinstall seat with new fasteners. 6. If damaged — REPLACE seat cushion assembly with new fasteners.
Harness and connectors	<ol style="list-style-type: none"> 1. Check connectors for poor connection, damage, and terminals for deformities. 2. Check harness for binding, chafing, cuts, or deformities. 3. If no damage is found, reinstall the harness and connectors. 4. If damaged —REPLACE the damaged harness. Do not attempt to repair, splice or modify any SRS harness.
Instrument panel assembly	If the passenger front air bag has NOT deployed: <ol style="list-style-type: none"> 1. Visually check instrument panel for damage. 2. If no damage is found, reinstall the instrument panel assembly. 3. If damaged—REPLACE the instrument panel assembly.

A
B
C
D
E
F
G
SB
I
J

For Side and Rollover Collision

INFOID:000000011560941

FOR SIDE AND ROLLOVER COLLISION: When SRS is activated in a collision

CAUTION:

Due to varying models and option levels, not all parts listed in the chart below apply to all vehicles.

WORK PROCEDURE

1. Before performing any of the following steps, ensure that all vehicle body and structural repairs have been completed.
2. Replace the following components:
 - Front seat back assembly (on the side on which side air bag is activated).
 - Door finisher (on the side on which door-mounted curtain air bag is activated).
 - Pop-up roll bar assemblies and pop-up roll bar covers.
 - Side air bag (satellite) sensor LH/RH (on the side on which side air bag is activated).
 - Diagnosis sensor unit.
 - Seat belt pre-tensioner assemblies.
3. Check the SRS components and the related parts using the following table. Replace any SRS components and the related parts showing visible signs of damage (dents, cracks, deformation, etc.).
4. Perform self-diagnosis using CONSULT and "AIR BAG" warning lamp. Refer to [SRC-15, "SRS Operation Check"](#) for details. Make sure entire SRS operates properly.
5. After the work is completed, perform self-diagnosis to check that no malfunction is detected. Refer to [SRC-17, "Trouble Diagnosis without CONSULT"](#).

SRS INSPECTION (FOR SIDE AND ROLLOVER COLLISION)

COLLISION DIAGNOSIS

< BASIC INSPECTION >

Part	Inspection
Side curtain air bag module LH	If the side curtain air bag LH has deployed: REPLACE the side curtain air bag module LH. Install with new fasteners.
Side curtain air bag module RH	If the side curtain air bag RH has deployed: REPLACE the side curtain air bag module RH. Install with new fasteners.
Front side air bag module LH	If the front side air bag LH has deployed: REPLACE front seatback assembly LH.
Front side air bag module RH	If the front side air bag RH has deployed: REPLACE front seatback assembly RH.
Side air bag (satellite) sensor (LH or RH)	If any of the SRS components have deployed: REPLACE the side air bag (satellite) sensor on the collision side with new fasteners.
Diagnosis sensor unit	If any of the SRS components have deployed: REPLACE the diagnosis sensor unit with new fasteners.
Seat belt pre-tensioner assemblies (All applicable locations: buckle, retractor, lap outer)	If either the driver or passenger seat belt pre-tensioner* has been activated: REPLACE all seat belt pre-tensioner assemblies with new fasteners. *: Confirm seat belt pre-tensioner activation using CONSULT only.
Center inner pillar	1. Check the center inner pillar on the collision side for damage (dents, cracks, deformation). 2. If damaged —REPAIR the center inner pillar.
Seat (if equipped with front side air bag)	If either the front LH or front RH side air bag modules has been deployed: REPLACE front seatback assembly on the deployed side.
Trim/headlining	1. Check for visible signs of damage (dents, cracks, deformation) of the interior trim on the collision side. 2. If damaged — REPLACE the damaged trim parts.
Door-mounted curtain air bag module LH	If the door-mounted curtain air bag module LH has been deployed: REPLACE the door finisher LH and door-mounted curtain air bag module. Install with new fasteners.
Door-mounted curtain air bag module RH	If the door-mounted curtain air bag module RH has been deployed: REPLACE the door finisher RH and door-mounted curtain air bag module. Install with new fasteners.
Pop-up roll bar assemblies	If the pop-up roll bar has deployed: REPLACE pop-up roll bar assemblies and pop-up roll bar covers. Install with new fasteners.

FOR SIDE AND ROLLOVER COLLISION: When SRS is not activated in a collision

CAUTION:

Due to varying models and option levels, not all parts listed in the chart below apply to all vehicles.

WORK PROCEDURE

1. Before performing any of the following steps, ensure that all vehicle body and structural repairs have been completed.
2. Check the SRS components and the related parts using the following table.
 - If the front seat back assembly is damaged, the front seat back assembly must be replaced.
 - If the door finisher assembly is damaged, the door finisher assembly and door-mounted curtain air bag module must be replaced.
3. Perform self-diagnosis using CONSULT and "AIR BAG" warning lamp. Refer to [SRC-15, "SRS Operation Check"](#) for details. Make sure entire SRS operates properly.
4. After the work is completed, perform self-diagnosis to check that no malfunction is detected. Refer to [SRC-17, "Trouble Diagnosis without CONSULT"](#).

SRS INSPECTION (FOR SIDE AND ROLLOVER COLLISION)

COLLISION DIAGNOSIS

< BASIC INSPECTION >

Part	Inspection	
Side curtain air bag module LH	If the side curtain air bag LH has NOT deployed: 1. Check for visible signs of damage (dents, tears, deformation) of the center pillar on the collision side. 2. If damaged - Remove the side curtain air bag module LH. 3. Check for visible signs of damage (tears etc.) of the side curtain air bag module LH. 4. Check harness and connectors for damage, and terminals for deformities. 5. If no damage is found, reinstall the side curtain air bag module LH with new fasteners. 6. If damaged — REPLACE the side curtain air bag module LH with new fasteners.	A B C
Side curtain air bag module RH	If the side curtain air bag RH has NOT deployed: 1. Check for visible signs of damage (dents, tears, deformation) of the center pillar on the collision side. 2. If damaged - Remove the side curtain air bag module RH. 3. Check for visible signs of damage (tears etc.) of the side curtain air bag module RH. 4. Check harness and connectors for damage, and terminals for deformities. 5. If no damage is found, reinstall the side curtain air bag module RH with new fasteners. 6. If damaged — REPLACE the side curtain air bag module RH with new fasteners.	D E
Front side air bag module LH	If the front LH side air bag has NOT deployed: 1. Check for visible signs of damage (dents, tears, deformation) of the seat back on the collision side. 2. Check harness and connectors for damage, and terminals for deformities. 3. If damaged — REPLACE the front seatback assembly LH.	F
Front side air bag module RH	If the front side air bag RH has NOT deployed: 1. Check for visible signs of damage (dents, tears, deformation) of the seat back on the collision side. 2. Check harness and connectors for damage, and terminals for deformities. 3. If damaged — REPLACE the front seatback assembly RH.	G SB
Side air bag (satellite) sensor (LH or RH)	If none of the SRS components have been activated: 1. Remove the side air bag (satellite) sensor (LH or RH) on the collision side. Check harness connectors for damage, terminals for deformities, and harness for binding. 2. Check for visible signs of damage (dents, cracks, deformation) of the side air bag (satellite) sensor (LH or RH). 3. Install the side air bag (satellite) sensor (LH or RH) to check fit. 4. If no damage is found, reinstall the side air bag (satellite) sensor (LH or RH) with new fasteners. 5. If damaged — REPLACE the side air bag (satellite) sensor (LH or RH) with new fasteners.	I J
Diagnosis sensor unit	If none of the SRS components have been activated: 1. Check case and bracket for dents, cracks or deformities. 2. Check connectors for damage, and terminals for deformities. 3. If no damage is found, reinstall the diagnosis sensor unit with new fasteners. 4. If damaged — REPLACE the diagnosis sensor unit with new fasteners.	K L
Seat belt pre-tensioner assemblies (All applicable locations: buckle, retractor, lap outer)	If the pre-tensioners have NOT been activated: 1. Remove seat belt pre-tensioners. Check harness cover and connectors for damage, terminals for deformities, and harness for binding. 2. Check belts for damage and anchors for loose mounting. 3. Check retractor for smooth operation. 4. Check seat belt adjuster for damage. 5. Check for deformities of the center pillar inner. 6. If the center pillar inner has no damage, REPLACE the seat belt pre-tensioner assembly. 7. If no damage is found, reinstall seat belt pre-tensioner assembly. 8. If damaged —REPLACE. Install the seat belt pre-tensioners with new fasteners.	M N O
Seat (with front side air bag)	If the front LH or front RH side air bag modules have NOT deployed: 1. Visually check the seat on the collision side. 2. Remove the seat on the collision side and check the following for damage and deformities. - Harness, connectors and terminals - Frame and recliner (for front and rear seat), and also adjuster and slides (for front seat) 3. If no damage is found, reinstall the seat. 4. If damaged— REPLACE the damaged seat parts using new fasteners. If the front seat back is damaged, the front seat back assembly must be replaced.	P

COLLISION DIAGNOSIS

< BASIC INSPECTION >

Part	Inspection
Center inner pillar	<ol style="list-style-type: none"> 1. Check the center inner pillar on the collision side for damage (dents, cracks, deformation, etc.). 2. If damaged - REPAIR the center inner pillar.
Trim/headlining	<ol style="list-style-type: none"> 1. Check for visible signs of damage (dents, cracks, deformation, etc.) of the interior trim on the collision side. 2. If damaged - REPLACE the damaged trim parts.
Door-mounted curtain air bag module LH	<p>If the door-mounted curtain air bag LH has NOT deployed:</p> <ol style="list-style-type: none"> 1. Check for visible signs of damage (dents, tears, deformation, etc.) of the door finisher on the collision side. 2. If damaged - REPLACE the door finisher LH with new fasteners. 3. Check for visible signs of damage (tears etc.) of the door-mounted curtain air bag module LH. 4. Check harness and connectors for damage, and terminals for deformities. 5. If no damage is found, reinstall door finisher. <p>CAUTION: When removing door mounted curtain air bag module from door finisher, do not reuse door finisher.</p> <ol style="list-style-type: none"> 6. If damaged - REPLACE the door finisher LH and door-mounted curtain air bag module LH with new fasteners.
Door-mounted curtain air bag module RH	<p>If the door-mounted curtain air bag RH has NOT deployed:</p> <ol style="list-style-type: none"> 1. Check for visible signs of damage (dents, tears, deformation, etc.) of the door finisher on the collision side. 2. If damaged - REPLACE the door finisher RH with new fasteners. 3. Check for visible signs of damage (tears etc.) of the door-mounted curtain air bag module RH. 4. Check harness and connectors for damage, and terminals for deformities. 5. If no damage is found, reinstall door finisher. <p>CAUTION: When removing door mounted curtain air bag module from door finisher, do not reuse door finisher.</p> <ol style="list-style-type: none"> 6. If damaged - REPLACE the door finisher RH and door-mounted curtain air bag module RH with new fasteners.
Pop-up roll bar	<p>If the pop-up roll bar NOT deployed:</p> <ol style="list-style-type: none"> 1. Check for visible signs of damage (dents, tears, deformation, etc.) of the pop-up roll bar. 2. If damaged - REPLACE the pop-up roll bar with new fasteners. 3. Check harness and connectors for damage, and terminals for deformities. 4. If no damage is found, reinstall the pop-up roll bar with new fasteners. 5. Check for visible signs of damage (dents, cracks, deformation, etc.) of the seatback support brace assembly. 6. If damaged - REPAIR the seatback support brace assembly.

SEAT BELTS

< REMOVAL AND INSTALLATION >

REMOVAL AND INSTALLATION

SEAT BELTS

Removal and Installation of Front Seat Belt

INFOID:000000011560942

CREW CAB

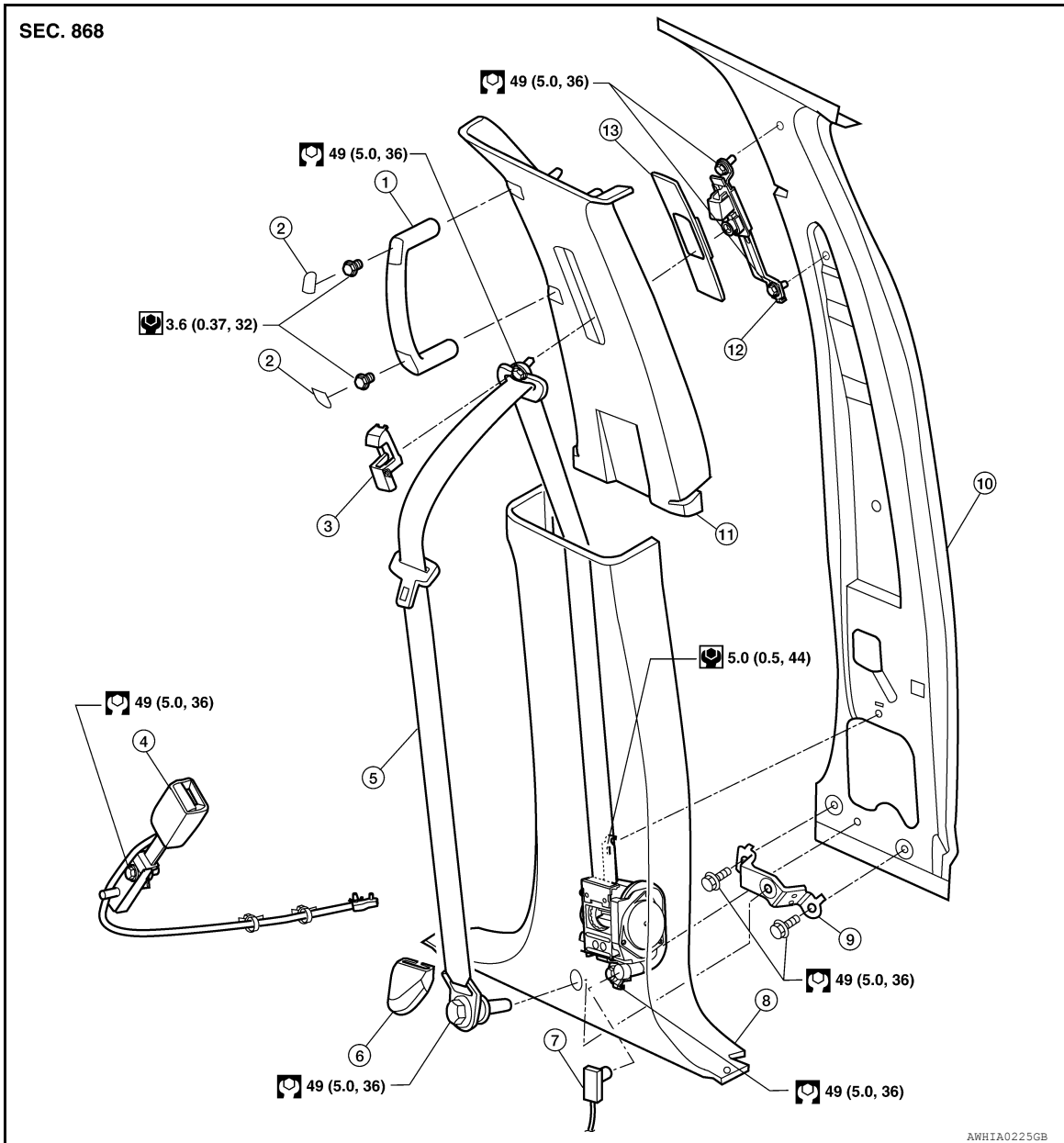

- | | | |
|--|---|-------------------------------|
| 1. Assist handle | 2. Assist handle screw covers | 3. D-ring anchor bolt cover |
| 4. Seat belt buckle | 5. Seat belt retractor and belt assembly (LH) | 6. Anchor cover |
| 7. Seat belt pre-tensioner connector | 8. Center pillar lower finisher | 9. Seat belt anchor bracket |
| 10. Center pillar | 11. Center pillar upper finisher | 12. Seat belt height adjuster |
| 13. Seat belt height adjuster finisher | | |

A
B
C
D
E
F
G
SB
I
J
K
L
M
N
O
P

SEAT BELTS

< REMOVAL AND INSTALLATION >

KING CAB

SEC. 868

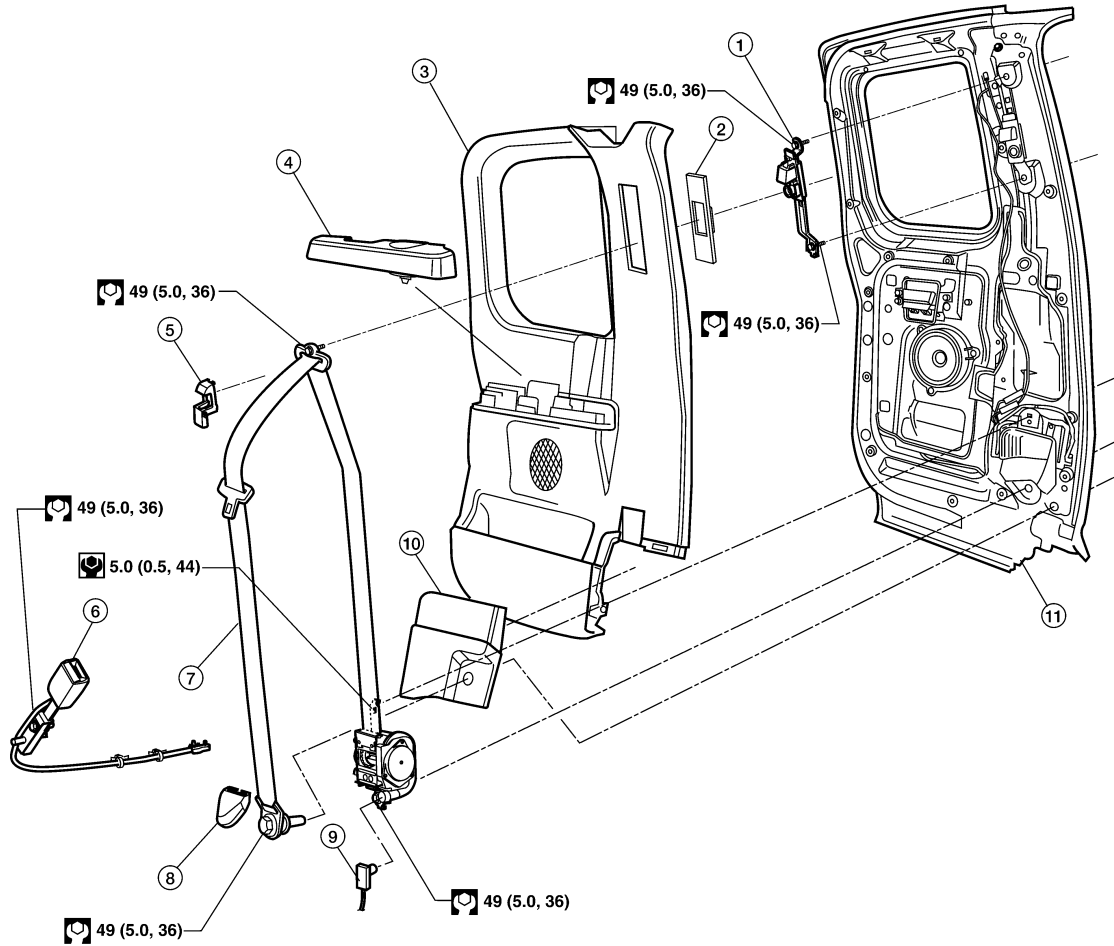

W1IA0991E

- | | | |
|---|---------------------------------------|--------------------------------------|
| 1. Seat belt height adjuster | 2. Seat belt height adjuster finisher | 3. Door finisher |
| 4. Armrest | 5. D-ring anchor bolt cover | 6. Seat belt buckle |
| 7. Seat belt retractor and belt assembly (LH) | 8. Anchor cover | 9. Seat belt pre-tensioner connector |
| 10. Lower door finisher | 11. Rear door (LH) | |

REMOVAL AND INSTALLATION OF SEAT BELT RETRACTOR

CAUTION:

- Before servicing SRS, turn the ignition switch off, disconnect both battery terminals and wait at least three minutes.

SEAT BELTS

< REMOVAL AND INSTALLATION >

- For installing/removing seat belt pre-tensioner connector, insert a thin screwdriver wrapped in tape into the notch, lift the lock and remove the connector.
- Install the connector with the lock raised, and push the lock into the connector.

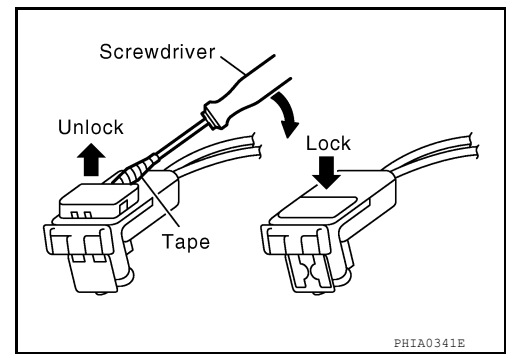

Removal - Crew Cab

CAUTION:

Before servicing the SRS, turn the ignition switch off, disconnect the battery terminals and wait at least three minutes.

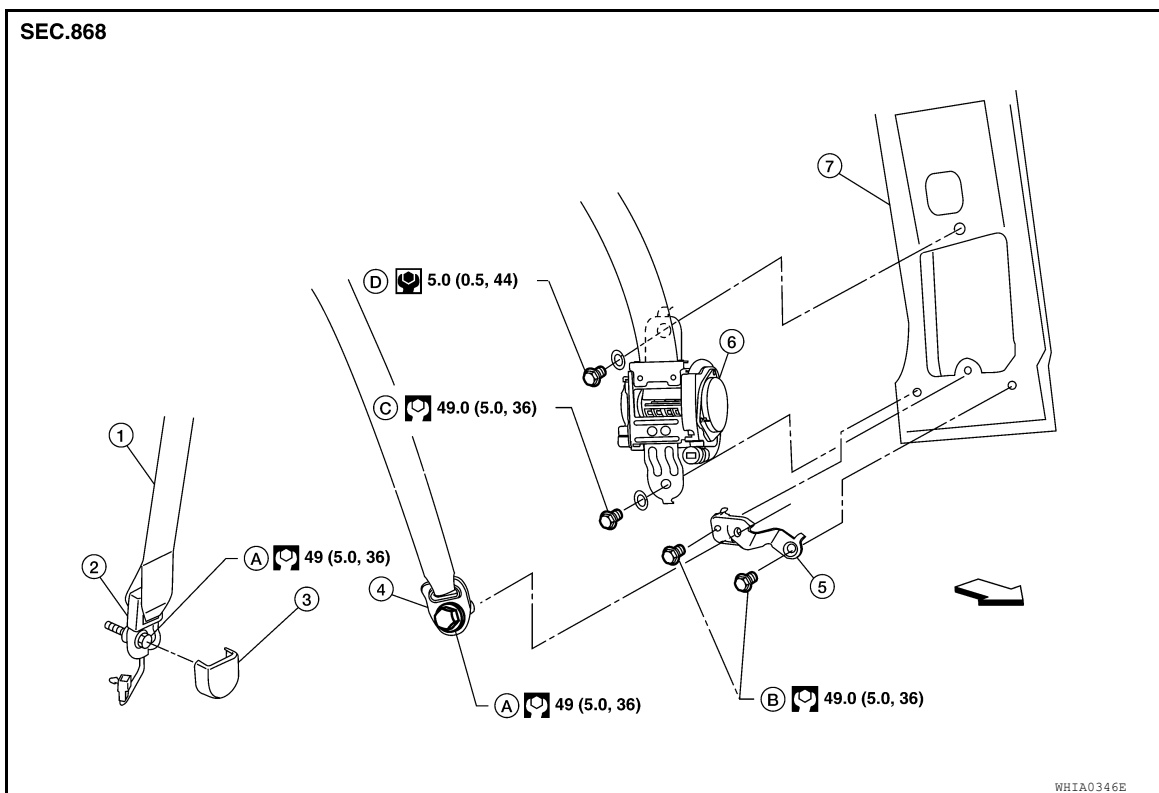

- | | | |
|---|---|---|
| 1. Seat belt retractor and belt assembly RH | 2. Seat belt lower anchor RH (seat belt tension sensor) | 3. Anchor cover RH (LH similar) |
| 4. Seat belt lower anchor LH | 5. Seat belt anchor bracket | 6. Seat belt retractor and belt assembly LH |
| 7. Center pillar | A. Lower anchor bolt | B. Anchor bracket bolt |
| C. Retractor anchor bolt | D. Retractor bolt upper | ⇐ Front |

1. Disconnect both the negative and positive battery terminals, then wait at least three minutes. Refer to [PG-85, "Removal and Installation"](#).
2. Remove the D-ring anchor bolt cover and anchor bolt.
3. Remove the anchor cover and lower seat belt assembly anchor bolt.
 - On RH side, disconnect the seat belt tension sensor.
4. Remove the center pillar lower finisher. Refer to [INT-15, "Removal and Installation"](#).
5. Remove the seat belt retractor and belt assembly lower anchor bolt and upper bolt.
6. Disconnect the harness connector from the seat belt pre-tensioner.
7. Remove the front seat belt retractor and belt assembly.

SEAT BELTS

< REMOVAL AND INSTALLATION >

Installation - Crew Cab

Installation is in the reverse order of removal.

- Install the seat belt retractor upper bolt first.
- Make sure seat belt height adjuster is locked in the lowest position during installation.

Removal - King Cab

CAUTION:

Before servicing the SRS, turn the ignition switch off, disconnect the battery terminals and wait at least three minutes.

1. Disconnect both the negative and positive battery terminals, then wait at least three minutes. Refer to [PG-85. "Removal and Installation"](#).
2. Remove D-ring anchor bolt cover and bolt.
3. Remove anchor cover and bolt.
4. Remove lower door finisher.
5. Disconnect the harness connector from the seat belt pre-tensioner.
6. Remove seat belt retractor and belt assembly.

Installation - King Cab

Installation is in the reverse order of removal.

REMOVAL AND INSTALLATION OF SEAT BELT BUCKLE

Removal - Bucket Seat

1. Remove the front seat. Refer to [SE-34. "Removal and Installation - Front Seat Assembly"](#).
2. Remove screw and seat cushion inner finisher.
3. Remove the anchor bolt and buckle.
4. Disconnect the buckle switch connector from the seat connector.

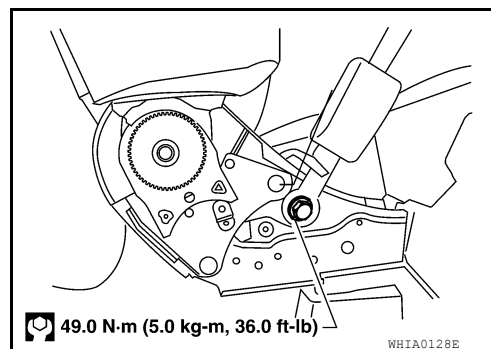

Installation - Bucket Seat

CAUTION:

- **Passenger seat is equipped with Occupant Classification System sensor and control module. Do not disassemble front passenger seat cushion assembly or remove trim as this will affect the Occupant Classification System calibration.**
- **On passenger seat during installation, the wire harness clips must be installed in the holes they were originally in.**

Installation is in the reverse order of removal.

REMOVAL AND INSTALLATION OF CENTER BENCH SEAT BELT AND SEAT BELT BUCKLE

SEAT BELTS

< REMOVAL AND INSTALLATION >

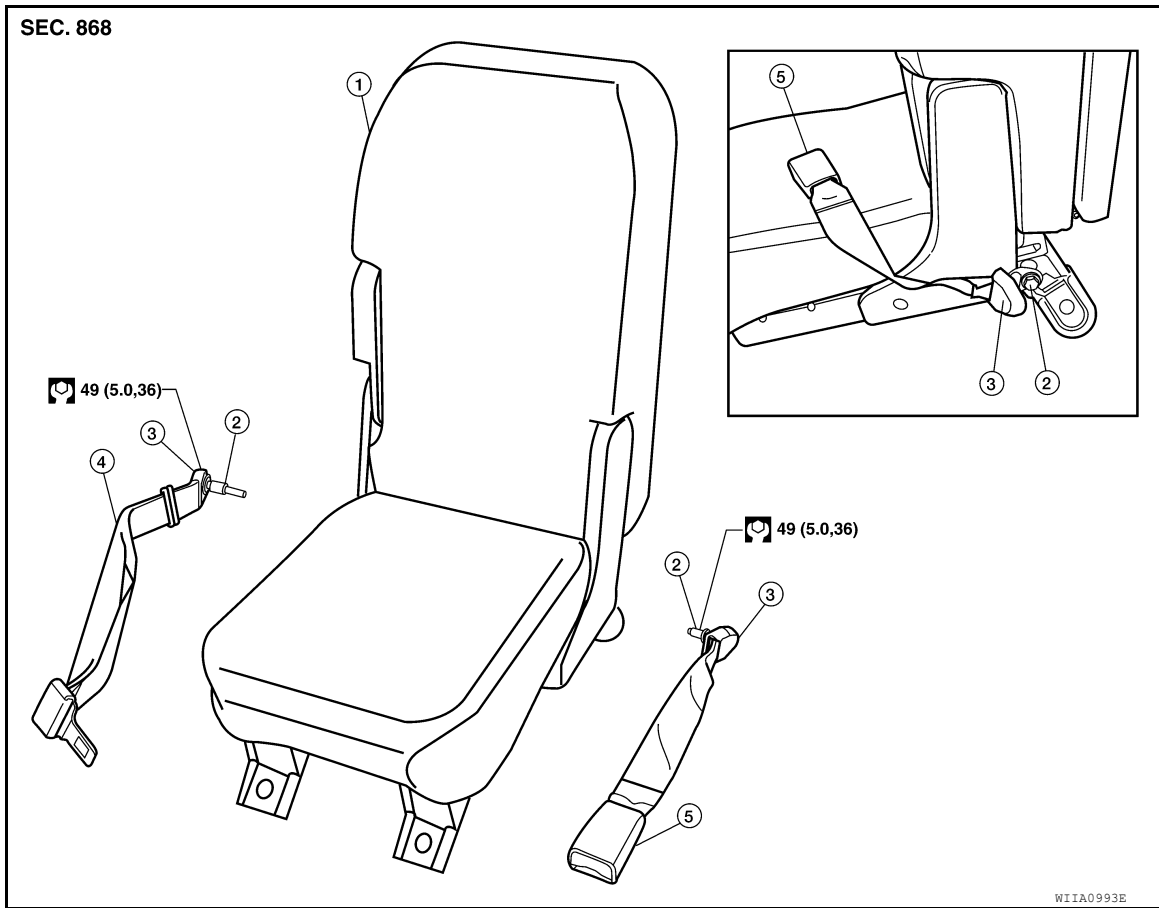

- | | | |
|-----------------------|---------------------------|-----------------------|
| 1. Center front seat | 2. Seat belt anchor bolts | 3. Anchor bolt covers |
| 4. Seat belt assembly | 5. Seat belt buckle | |

Removal

1. Remove center front seat. Refer to [SE-34, "Removal and Installation - Front Seat Assembly"](#).
2. Remove anchor bolt cover, bolt and seat belt.
3. Remove anchor bolt cover, bolt and seat belt buckle.

Installation

Installation is in the reverse order of removal.

A
B
C
D
E
F
G
SB
I
J
K
L
M
N
O
P

SEAT BELTS

< REMOVAL AND INSTALLATION >

Removal and Installation of Rear Seat Belt

INFOID:000000011560943

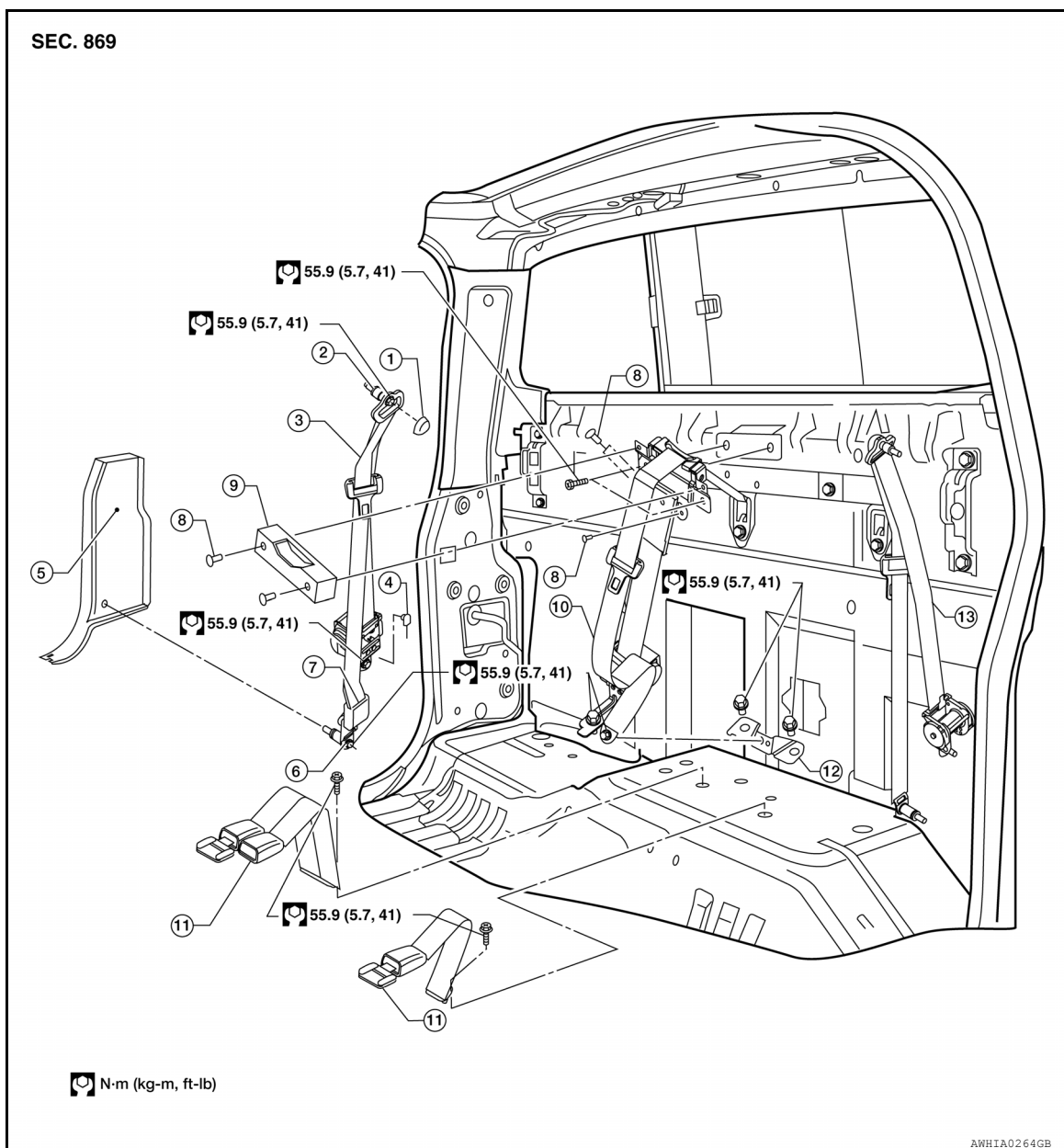

- | | | |
|--|------------------------|---|
| 1. D-ring anchor bolt cover | 2. D-ring anchor | 3. Seat belt retractor and belt assembly RH |
| 4. Seat belt pre-tensioner connector | 5. Lower side finisher | 6. Seat belt lower anchor |
| 7. Seat belt lower anchor cover | 8. Push pins | 9. Center anchor bracket cover |
| 10. Center seat belt retractor and belt assembly | 11. Seat belt buckles | 12. Center seat belt anchor bracket |
| 13. Seat belt retractor and belt assembly LH | | |

REMOVAL

1. Remove rear kicking plates. Refer to [INT-15. "Removal and Installation"](#).
2. Remove rear seat assembly. Refer to [SE-43. "Removal and Installation"](#).
3. Remove seat belt D-ring anchor bolt cover and bolt.
4. Remove seat belt lower anchor cover and bolt.

SEAT BELTS

< REMOVAL AND INSTALLATION >

5. Remove lower side finisher. Refer to [INT-15. "Removal and Installation"](#).
6. Remove seat belt retractor anchor bolt and the seat belt assembly.
7. Remove center seat belt lower anchor bolt.
8. Remove center seat belt retractor.
9. Remove center anchor bracket cover.
10. Remove push pins from center seat belt webbing sleeve.
11. Remove bolts from anchor bracket and remove center seat belt retractor and belt assembly.
12. Remove center belt bracket from floor.
13. Remove seat belt buckles.

INSTALLATION

- Installation is in the reverse order of removal.
- Attach rear center seat belt retractor anchor bracket bolts before seat installation.
 - Attach rear center seat belt retractor anchor bolt after seat installation with the seat cushion raised.

A
B
C
D
E
F
G
SB
I
J
K
L
M
N
O
P

LATCH (LOWER ANCHORS AND TETHER FOR CHILDREN) SYSTEM

< REMOVAL AND INSTALLATION >

LATCH (LOWER ANCHORS AND TETHER FOR CHILDREN) SYSTEM

Removal and Installation

INFOID:000000011560944

NOTE:

The LATCH (Lower Anchors and Tether for Children) system is not serviceable.

TOP TETHER STRAP CHILD RESTRAINT

< REMOVAL AND INSTALLATION >

TOP TETHER STRAP CHILD RESTRAINT

Removal and Installation

INFOID:000000011560945

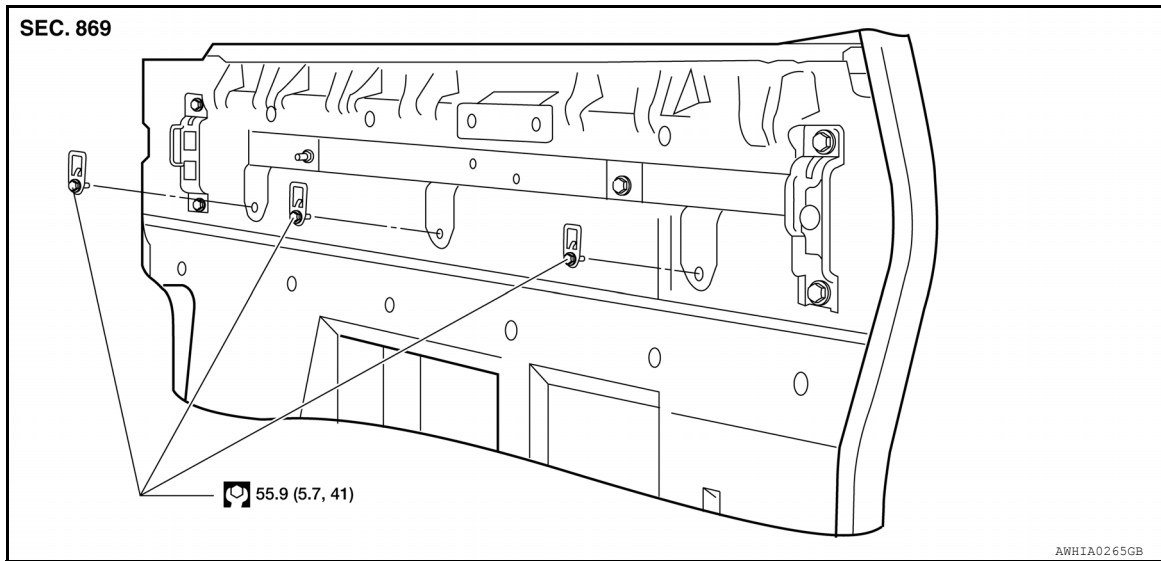

REMOVAL

1. Fold rear seat backs down.
2. Remove bolts and remove tether anchors.

INSTALLATION

Installation is in the reverse order of removal.

A
B
C
D
E
F
G
SB
I
J
K
L
M
N
O
P