

SECTION **BRC**

BRAKE CONTROL SYSTEM

A
B
C
D
E

CONTENTS

ABS		BRC
PRECAUTIONS	4	
Precautions for Supplemental Restraint System (SRS) "AIR BAG" and "SEAT BELT PRE-TENSIONER"	4	
Precautions for Brake System	4	
Precautions When Using CONSULT-II	4	
CHECK POINTS FOR USING CONSULT-II	4	
Precautions for Brake Control	5	
Precautions for CAN System	5	
Wiring Diagrams and Trouble Diagnosis	6	
PREPARATION	7	
Special Service Tool	7	
Commercial Service Tools	7	
SYSTEM DESCRIPTION	8	
System Components	8	
ABS Function	8	
EBD Function	8	
Fail-Safe Function	8	
ABS/EBD SYSTEM	8	
Hydraulic Circuit Diagram	9	
CAN COMMUNICATION	10	
System Description	10	
TROUBLE DIAGNOSIS	11	
How to Perform Trouble Diagnoses for Quick and Accurate Repair	11	
INTRODUCTION	11	
WORK FLOW	12	
CLARIFY CONCERN	13	
EXAMPLE OF DIAGNOSIS SHEET	13	
Component Parts and Harness Connector Location	14	
Schematic	15	
Wiring Diagram — ABS —	16	
Basic Inspection	20	
BRAKE FLUID LEVEL, FLUID LEAK, AND BRAKE PAD INSPECTION	20	
POWER SYSTEM TERMINAL LOOSENESS AND BATTERY INSPECTION	20	
ABS WARNING LAMP INSPECTION	20	
Warning Lamp and Indicator Timing	21	
Control Unit Input/Output Signal Standard	21	
REFERENCE VALUE FROM CONSULT-II	21	
CONSULT-II Function (ABS)	23	
CONSULT-II BASIC OPERATION PROCEDURE	23	
SELF-DIAGNOSIS	24	
DATA MONITOR	26	
ACTIVE TEST	27	
TROUBLE DIAGNOSIS FOR SELF-DIAGNOSTIC ITEMS	29	
Wheel Sensor System	29	
ABS Control Unit Inspection	30	
Solenoid Valve System Inspection	31	
Actuator Motor, Motor Relay, and Circuit Inspection	32	
ABS Control Unit Power and Ground Systems Inspection	33	
CAN Communication System Inspection	34	
TROUBLE DIAGNOSES FOR SYMPTOMS	35	
ABS Works Frequently	35	
Unexpected Pedal Action	36	
Long Stopping Distance	37	
ABS Does Not Work	37	
Pedal Vibration or ABS Operation Noise	37	
ABS Warning Lamp Does Not Come On When Ignition Switch Is Turned On	38	
ABS Warning Lamp Stays On When Ignition Switch Is Turned On	38	
WHEEL SENSORS	39	
Removal and Installation	39	
REMOVAL	39	
INSTALLATION	39	
SENSOR ROTOR	40	
Removal and Installation	40	
FRONT	40	
REAR	40	
ACTUATOR AND ELECTRIC UNIT (ASSEMBLY)...	41	
Removal and Installation	41	
REMOVAL	41	
INSTALLATION	42	

BRC

G
H
I
J
K
L
M

ABLS/ABS

PRECAUTIONS	43
Precautions for Supplemental Restraint System (SRS) "AIR BAG" and "SEAT BELT PRE-TENSIONER"	43
Precautions for Brake System	43
Precautions When Using CONSULT-II	43
CHECK POINTS FOR USING CONSULT-II	43
Precautions for Brake Control	44
Precautions for CAN System	44
Wiring Diagrams and Trouble Diagnosis	45
PREPARATION	46
Special Service Tool	46
Commercial Service Tools	46
SYSTEM DESCRIPTION	47
System Components	47
ABS Function	48
EBD Function	48
ABLS Function	48
Fail-Safe Function	48
ABS/EBD SYSTEM	48
ABLS SYSTEM	48
Hydraulic Circuit Diagram	49
CAN COMMUNICATION	50
System Description	50
TROUBLE DIAGNOSIS	51
How to Perform Trouble Diagnoses for Quick and Accurate Repair	51
INTRODUCTION	51
WORK FLOW	52
CLARIFY CONCERN	53
EXAMPLE OF DIAGNOSIS SHEET	53
Component Parts and Harness Connector Location ..	54
Schematic	55
Wiring Diagram — ABLS —	56
Basic Inspection	60
BRAKE FLUID LEVEL, FLUID LEAK, AND BRAKE PAD INSPECTION	60
POWER SYSTEM TERMINAL LOOSENESS AND BATTERY INSPECTION	60
ABS WARNING LAMP AND SLIP INDICATOR LAMP INSPECTION	60
Warning Lamp and Indicator Timing	61
Control Unit Input/Output Signal Standard	61
REFERENCE VALUE FROM CONSULT-II	61
CONSULT-II Function (ABS)	64
CONSULT-II BASIC OPERATION PROCEDURE	64
SELF-DIAGNOSIS	65
DATA MONITOR	67
ACTIVE TEST	69
TROUBLE DIAGNOSIS FOR SELF-DIAGNOSTIC ITEMS	72
Wheel Sensor System Inspection	72
Engine System Inspection	73
ABS/ABLS Control Unit Inspection	74
Solenoid and Change-Over Valve System Inspection	74

Actuator Motor, Motor Relay, and Circuit Inspection ..	75
Stop Lamp Switch System Inspection	76
ABS/ABLS Control Unit Power and Ground Systems Inspection	77
Brake Fluid Level Switch System Inspection	78
Pressure Sensor System Inspection	78
CAN Communication System Inspection	81
TROUBLE DIAGNOSES FOR SYMPTOMS	82
ABS Works Frequently	82
Unexpected Pedal Action	83
Long Stopping Distance	84
ABS Does Not Work	84
Pedal Vibration or ABS Operation Noise	84
ABS Warning Lamp Does Not Come On When Ignition Switch Is Turned On	85
ABS Warning Lamp Stays On When Ignition Switch Is Turned On	85
WHEEL SENSORS	86
Removal and Installation	86
REMOVAL	86
INSTALLATION	86
SENSOR ROTOR	87
Removal and Installation	87
FRONT	87
REAR	87
ACTUATOR AND ELECTRIC UNIT (ASSEMBLY) ..	88
Removal and Installation	88
REMOVAL	88
INSTALLATION	89

VDC/TCS/ABS

PRECAUTIONS	90
Precautions for Supplemental Restraint System (SRS) "AIR BAG" and "SEAT BELT PRE-TENSIONER"	90
Precautions for Brake System	90
Precautions When Using CONSULT-II	90
CHECK POINTS FOR USING CONSULT-II	90
Precautions for Brake Control	91
Precautions for CAN System	91
Wiring Diagrams and Trouble Diagnosis	92
PREPARATION	93
Special Service Tool	93
Commercial Service Tools	93
SYSTEM DESCRIPTION	94
System Components	94
ABS Function	95
EBD Function	95
TCS Function	95
VDC Function	95
Fail-Safe Function	95
ABS/EBD SYSTEM	96
VDC/TCS SYSTEM	96
ACTIVE BOOSTER	96
Hydraulic Circuit Diagram	96
CAN COMMUNICATION	97
System Description	97

TROUBLE DIAGNOSIS	98	Pressure Sensor System Inspection	138	
How to Perform Trouble Diagnoses for Quick and Accurate Repair	98	CAN Communication System Inspection	140	A
INTRODUCTION	98	Inspection For Self-diagnosis Result "ST ANGLE SEN SIGNAL"	141	
WORK FLOW	99	Inspection For Self-diagnosis Result "DECEL G SEN SET"	141	B
CLARIFY CONCERN	100	VDC OFF Indicator lamp Does Not Illuminate	141	
EXAMPLE OF DIAGNOSIS SHEET	100	Component Inspection	142	C
Component Parts and Harness Connector Location	101	VDC OFF SWITCH	142	
Schematic	102	TROUBLE DIAGNOSES FOR SYMPTOMS	143	
Wiring Diagram — VDC —	103	ABS Works Frequently	143	D
Basic Inspection	110	Unexpected Pedal Action	144	
BRAKE FLUID LEVEL, FLUID LEAK, AND BRAKE PAD INSPECTION	110	Long Stopping Distance	145	E
POWER SYSTEM TERMINAL LOOSENESS AND BATTERY INSPECTION	110	ABS Does Not Work	145	
ABS WARNING LAMP, SLIP INDICATOR LAMP AND VDC OFF INDICATOR LAMP INSPECTION	110	Pedal Vibration or ABS Operation Noise	145	
Warning Lamp and Indicator Timing	111	ABS Warning Lamp Does Not Come On When Ignition Switch Is Turned On	146	
Control Unit Input/Output Signal Standard	111	ABS Warning Lamp Stays On When Ignition Switch Is Turned On	146	BRC
REFERENCE VALUE FROM CONSULT-II	111	Vehicle Jerks During TCS/VDC Activation	147	
CONSULT-II Function (ABS)	115	ON-VEHICLE SERVICE	148	
CONSULT-II BASIC OPERATION PROCEDURE	115	Adjustment of Steering Angle Sensor Neutral Position	148	G
SELF-DIAGNOSIS	116	Calibration of Yaw Rate/Side/Decel G Sensor	148	
DATA MONITOR	119	WHEEL SENSORS	150	H
ACTIVE TEST	123	Removal and Installation	150	
TROUBLE DIAGNOSIS FOR SELF-DIAGNOSTIC ITEMS	125	REMOVAL	150	I
Wheel Sensor System Inspection	125	INSTALLATION	150	
Engine System Inspection	126	SENSOR ROTOR	151	J
ABS/TCS/VDC Control Unit Inspection	127	Removal and Installation	151	
Steering Angle Sensor System	127	FRONT	151	
Yaw Rate/Side/Decel G Sensor System Inspection	128	REAR	151	
Solenoid and VDC Change-Over Valve System Inspection	130	ACTUATOR AND ELECTRIC UNIT (ASSEMBLY)	152	K
Actuator Motor, Motor Relay, and Circuit Inspection	131	Removal and Installation	152	
Stop Lamp Switch System Inspection	132	REMOVAL	152	
ABS/TCS/VDC Control Unit Power and Ground Systems Inspection	133	INSTALLATION	153	
Brake Fluid Level Sensor System Inspection	134	STEERING ANGLE SENSOR	154	L
Active Booster System Inspection	135	Removal and Installation	154	
Delta Stroke Sensor System Inspection	136	G SENSOR	155	
		Removal and Installation	155	M
		REMOVAL	155	
		INSTALLATION	155	

PRECAUTIONS

PF0:0001

Precautions for Supplemental Restraint System (SRS) “AIR BAG” and “SEAT BELT PRE-TENSIONER”

EFS004P8

The Supplemental Restraint System such as “AIR BAG” and “SEAT BELT PRE-TENSIONER”, used along with a front seat belt, helps to reduce the risk or severity of injury to the driver and front passenger for certain types of collision. Information necessary to service the system safely is included in the SRS and SB section of this Service Manual.

WARNING:

- To avoid rendering the SRS inoperative, which could increase the risk of personal injury or death in the event of a collision which would result in air bag inflation, all maintenance must be performed by an authorized NISSAN/INFINITI dealer.
- Improper maintenance, including incorrect removal and installation of the SRS, can lead to personal injury caused by unintentional activation of the system. For removal of Spiral Cable and Air Bag Module, see the SRS section.
- Do not use electrical test equipment on any circuit related to the SRS unless instructed to in this Service Manual. SRS wiring harnesses can be identified by yellow and/or orange harnesses or harness connectors.

Precautions for Brake System

EFS004P9

CAUTION:

- Refer to [MA-11, "RECOMMENDED FLUIDS AND LUBRICANTS"](#) for recommended brake fluid.
- Never reuse drained brake fluid.
- Be careful not to splash brake fluid on painted areas; it may cause paint damage. If brake fluid is splashed on painted areas, wash it away with water immediately.
- To clean or wash all parts of master cylinder and disc brake caliper, use clean brake fluid.
- Never use mineral oils such as gasoline or kerosene. They will ruin rubber parts of the hydraulic system.
- Use flare nut wrench when removing and installing brake tube.
- If a brake fluid leak is found, the part must be disassembled without fail. Then it has to be replaced with a new one if a defect exists.
- Turn the ignition switch OFF and remove the connector of the ABS actuator and electric unit (control unit) or the battery terminal before performing the work.
- Always torque brake lines when installing.
- Burnish the brake contact surfaces after refinishing or replacing rotors, after replacing pads, or if a soft pedal occurs at very low mileage.

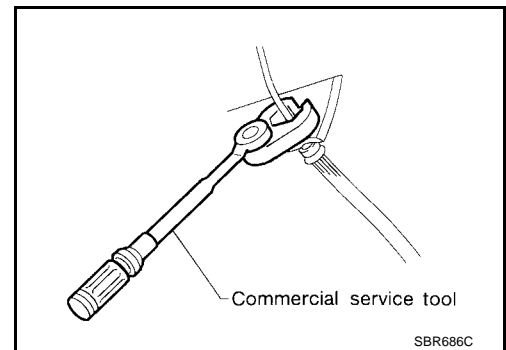

Refer to [BR-27, "BRAKE BURNISHING PROCEDURE"](#) (front disc brake) or [BR-32, "BRAKE BURNISHING PROCEDURE"](#) (rear disc brake).

WARNING:

- Clean brake pads and shoes with a waste cloth, then wipe with a dust collector.

Precautions When Using CONSULT-II

EFS004PA

When connecting CONSULT-II to data link connector, connect them through CONSULT-II CONVERTER.

CAUTION:

If CONSULT-II is used with no connection of CONSULT-II CONVERTER, malfunctions might be detected in self-diagnosis depending on control unit which carry out CAN communication.

CHECK POINTS FOR USING CONSULT-II

1. Has CONSULT-II been used without connecting CONSULT-II CONVERTER on this vehicle?
 - If YES, GO TO 2.
 - If NO, GO TO 5.

PRECAUTIONS

[ABS]

2. Is there any indication other than indications relating to CAN communication system in the self-diagnosis results?
 - If YES, GO TO 3.
 - If NO, GO TO 4.
3. Based on self-diagnosis results unrelated to CAN communication, carry out the inspection.
4. Malfunctions may be detected in self-diagnosis depending on control units carrying out CAN communication. Therefore, erase the self-diagnosis results.
5. Diagnose CAN communication system. Refer to [BRC-10, "CAN COMMUNICATION"](#).

Precautions for Brake Control

EFS004PB

- During ABS operation, the brake pedal may vibrate lightly and a mechanical noise may be heard. This is normal.
- Just after starting vehicle, the brake pedal may vibrate or a motor operating noise may be heard from engine compartment. This is a normal status of operation check.
- Stopping distance may be longer than that of vehicles without ABS when vehicle drives on rough, gravel, or snow-covered (fresh, deep snow) roads.
- When an error is indicated by ABS or another warning lamp, collect all necessary information from customer (what symptoms are present under what conditions) and check for simple causes before starting diagnosis. Besides electrical system inspection, check brake booster operation, brake fluid level, and fluid leaks.
- If incorrect tire sizes or types are installed on the vehicle or brake pads are not Genuine NISSAN parts, stopping distance or steering stability may deteriorate.
- If there is a radio, antenna or related wiring near control module, ABS function may have a malfunction or error.
- If aftermarket parts (car stereo, CD player, etc.) have been installed, check for incidents such as harness pinches, open circuits or improper wiring.

Precautions for CAN System

EFS004PC

- Do not apply voltage of 7.0V or higher to terminal to be measured.
- Maximum open terminal voltage of tester in use must be less than 7.0V.
- Before checking harnesses, turn ignition switch OFF and disconnect battery negative cable.
- Area to be repaired must be soldered and wrapped with tape. Make sure that fraying of twisted wire is within 110 mm (4.33 in).

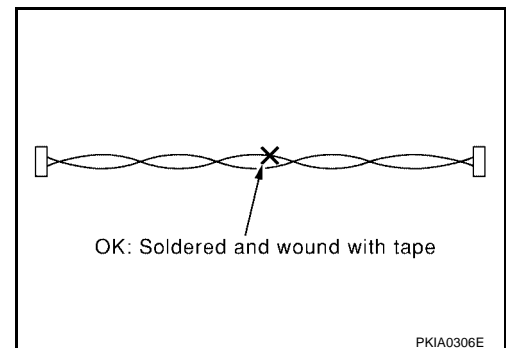

- Do not make a bypass connection to repaired area. (If the circuit is bypassed, characteristics of twisted wire will be lost.)

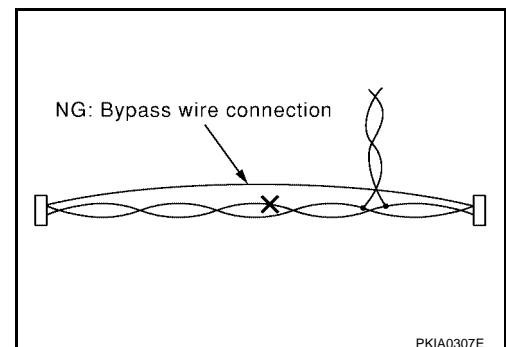

Wiring Diagrams and Trouble Diagnosis

When you read wiring diagrams, refer to the following:

- [GI-14, "How to Read Wiring Diagrams"](#).
- [PG-4, "POWER SUPPLY ROUTING CIRCUIT"](#).

When you perform trouble diagnosis, refer to the following:

- [GI-11, "HOW TO FOLLOW TEST GROUPS IN TROUBLE DIAGNOSES"](#).
- [GI-27, "How to Perform Efficient Diagnosis for an Electrical Incident"](#).

PREPARATION

[ABS]

PF0:00002

PREPARATION

Special Service Tool

EFS004PE

The actual shapes of Kent-Moore tools may differ from those of special service tools illustrated here.

Tool number (Kent-Moore No.) Tool name	Description
(J-45741) ABS active wheel sensor tester	Checking operation of ABS active wheel sensors
205-D002 (—) Bearing splitter	Removing axle shaft bearing

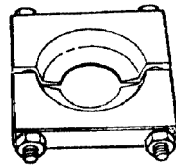
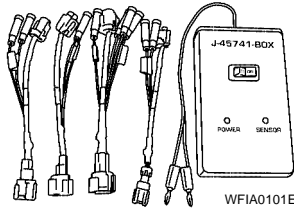

Commercial Service Tools

EFS004PF

Tool name	Description
1. Flare nut crowfoot 2. Torque wrench	Removing and installing brake piping a: 10mm (0.39 in)/12mm (0.47 in)

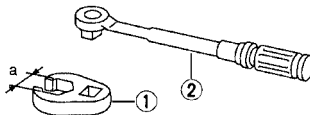

A
B
C
D
E
G
H
I
J
K
L
M

BRC

SYSTEM DESCRIPTION

PFP:00000

System Components

EFS004PG

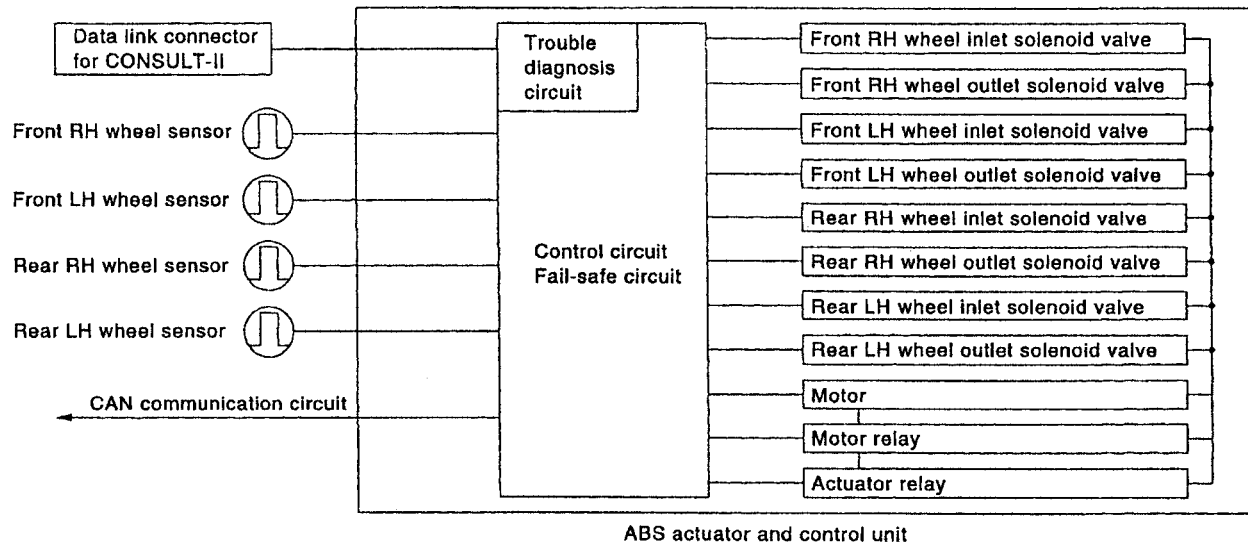

WFIA0118E

ABS Function

EFS004PH

- The Anti-Lock Brake System detects wheel revolution while braking and improves handling stability during sudden braking by electrically preventing wheel lockup. Maneuverability is also improved for avoiding obstacles.
- If the electrical system malfunctions, the Fail-Safe function is activated, the ABS becomes inoperative and the ABS warning lamp turns on.
- The electrical system can be diagnosed using CONSULT-II.
- During ABS operation, the brake pedal may vibrate lightly and a mechanical noise may be heard. This is normal.
- Just after starting the vehicle, the brake pedal may vibrate or a motor operating noise may be heard from engine compartment. This is a normal status of operation check.
- Stopping distance may be longer than that of vehicles without ABS when vehicle drives on rough, gravel, or snow-covered (fresh, deep snow) roads.

EBD Function

EFS004PI

- Electronic Brake Distribution is a function that detects subtle slippages between the front and rear wheels during braking, and it improves handling stability by electronically controlling the brake fluid pressure which results in reduced rear wheel slippage.
- If the electrical system malfunctions, the Fail-Safe function is activated, the EBD and ABS become inoperative, and the ABS warning lamp and brake warning lamp are turned on.
- The electrical system can be diagnosed using CONSULT-II.
- During EBD operation, the brake pedal may vibrate lightly and a mechanical noise may be heard. This is normal.
- Just after starting the vehicle, the brake pedal may vibrate or a motor operating noise may be heard from engine compartment. This is a normal status of operation check.

Fail-Safe Function

EFS004PJ

CAUTION:

If the Fail-Safe function is activated, perform the Self Diagnosis for ABS system.

ABS/EBD SYSTEM

In case of an electrical malfunction with the ABS, the ABS warning lamp will turn on. In case of an electrical malfunction with the EBD system, the brake warning lamp and the ABS warning lamp will turn on. The system will revert to one of the following conditions of the Fail-Safe function.

SYSTEM DESCRIPTION

[ABS]

1. For ABS malfunction, only the EBD is operative and the condition of the vehicle is the same condition of vehicles without ABS system.
2. For EBD malfunction, the EBD and ABS become inoperative, and the condition of the vehicle is the same as the condition of vehicles without ABS or EBD system.

Hydraulic Circuit Diagram

EFS004PK

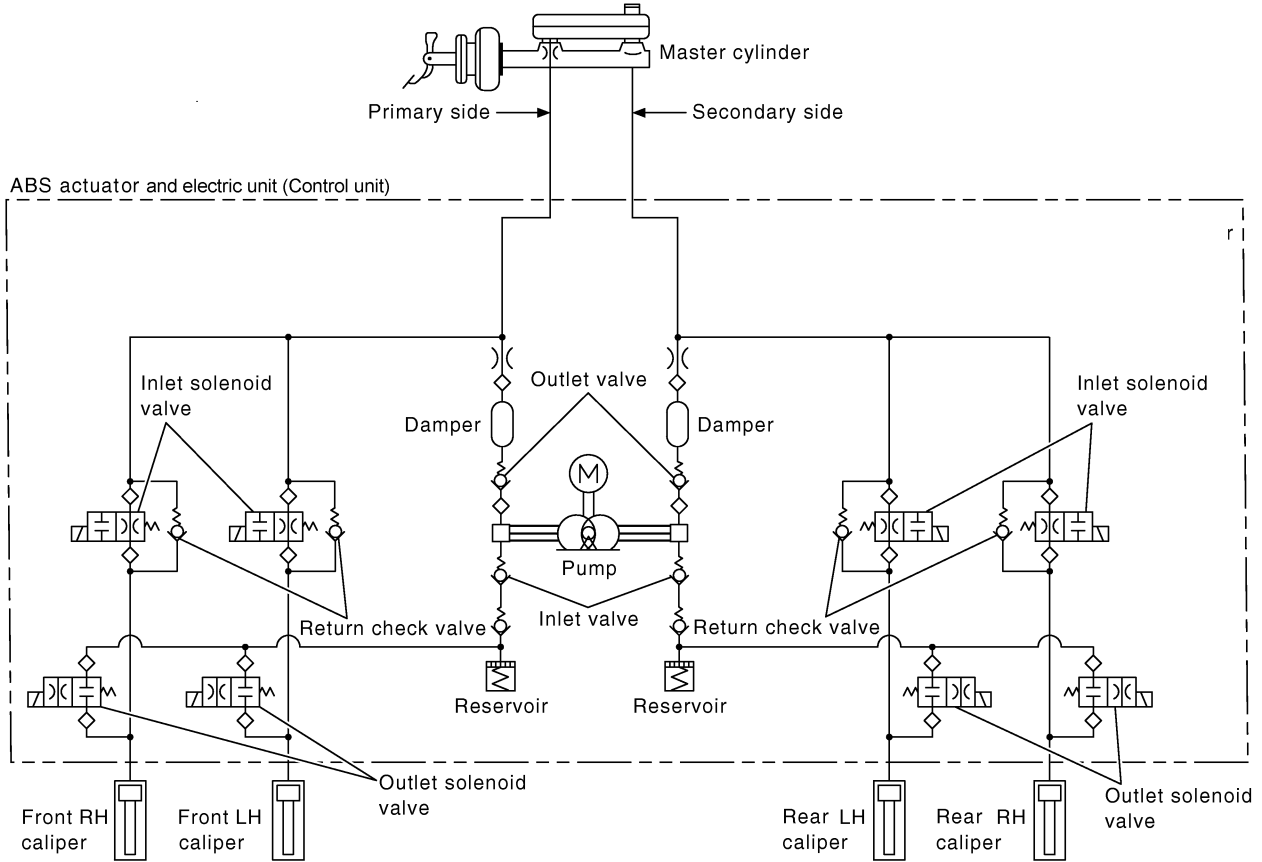

WFIA0214E

A
B
C
D
E
BRC
G
H
I
J
K
L
M

CAN COMMUNICATION

PF:23710

System Description

EF004PL

Refer to [LAN-7, "CAN COMMUNICATION"](#) .

TROUBLE DIAGNOSIS

How to Perform Trouble Diagnoses for Quick and Accurate Repair

INTRODUCTION

The ABS system has an electronic control unit to control major functions. The control unit accepts input signals from sensors and controls actuator operation. It is also important to check for conventional problems such as air leaks in the booster or lines, lack of brake fluid, or other problems with the brake system.

It is much more difficult to diagnose a problem that occurs intermittently rather than continuously. Most intermittent problems are caused by poor electrical connections or faulty wiring. In this case, careful checking of suspicious circuits may help prevent the replacement of good parts.

A visual check only may not find the cause of the problem, so a road test should be performed.

Before undertaking actual checks, take just a few minutes to talk with a customer who approaches with an ABS complaint. The customer is a very good source of information on such problems, especially intermittent ones. Through the talks with the customer, find out what symptoms are present and under what conditions they occur.

Start your diagnosis by looking for "conventional" problems first. This is one of the best ways to troubleshoot brake problems on an ABS equipped vehicle. Also check related Service Bulletins for information.

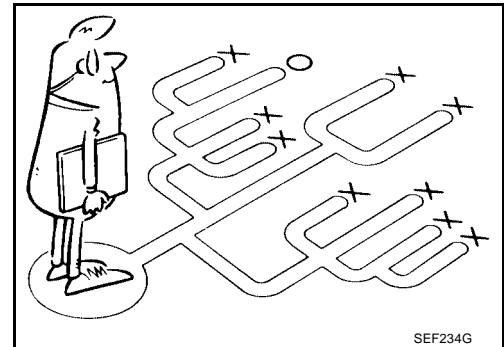
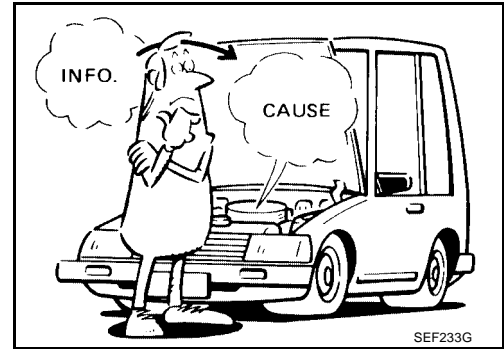

A
B
C
D
E
BRC
G
H
I
J
K
L
M

TROUBLE DIAGNOSIS

[ABS]

WORK FLOW

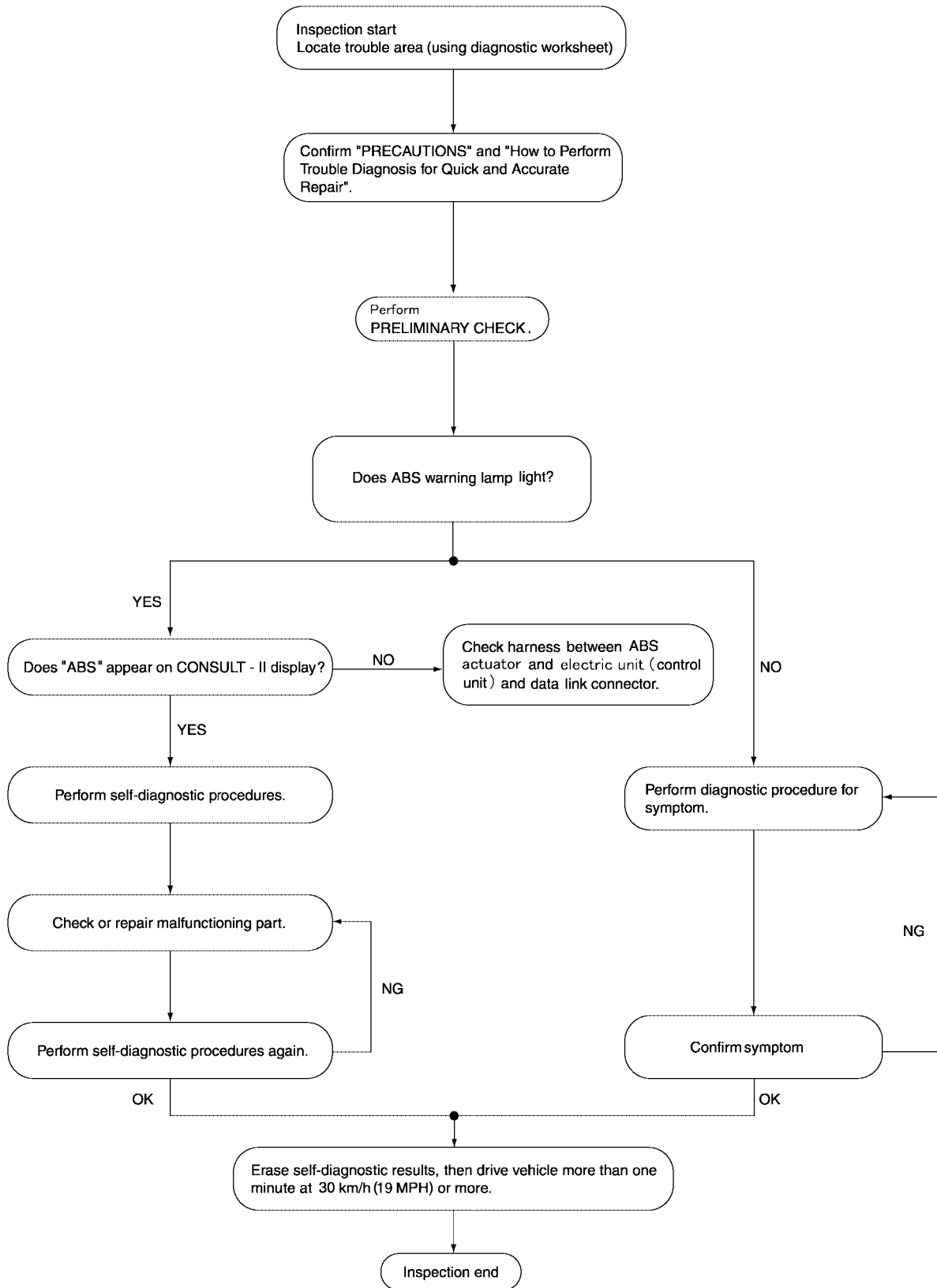

LFIA0197E

TROUBLE DIAGNOSIS

[ABS]

CLARIFY CONCERN

- A customer's description of a vehicle concern may vary depending on the individual. It is important to clarify the customer's concern.
- Ask the customer about what symptoms are present under what conditions. Use this information to reproduce the symptom while driving.
- It is also important to use the diagnosis sheet to understand what type of trouble the customer is having.

KEY POINTS

WHAT Vehicle model
WHEN Date, Frequencies
WHERE Road conditions
HOW Operating conditions,
 Weather conditions,
 Symptoms

SBR339B

EXAMPLE OF DIAGNOSIS SHEET

Customer name	Model & Year	VIN	
Engine #	Trans.	Mileage	
Incident Date	Manuf. Date	In Service Date	
Symptoms	<input type="checkbox"/> Noise and vibration (from engine compartment)	<input type="checkbox"/> ABS warning lamp activates	<input type="checkbox"/> Pedal operation
	<input type="checkbox"/> Noise and vibration (from axle)		<input type="checkbox"/> Large stroke pedal operation
	<input type="checkbox"/> ABS does not work (wheels lock when braking)	<input type="checkbox"/> ABS does not work (wheels slip when braking)	<input type="checkbox"/> Firm pedal
		<input type="checkbox"/> Lack of sense of acceleration	
Engine conditions	<input type="checkbox"/> When starting <input type="checkbox"/> After starting		
Road conditions	<input type="checkbox"/> Low friction road (<input type="checkbox"/> Snow <input type="checkbox"/> Gravel <input type="checkbox"/> Other) <input type="checkbox"/> Bumps/potholes		
Driving conditions	<input type="checkbox"/> Full-acceleration <input type="checkbox"/> High speed cornering <input type="checkbox"/> Vehicle speed: Greater than 10 km/h (6 MPH) <input type="checkbox"/> Vehicle speed: 10 km/h (6 MPH) or less <input type="checkbox"/> Vehicle is stopped		
Applying brake conditions	<input type="checkbox"/> Suddenly <input type="checkbox"/> Gradually		
Other conditions	<input type="checkbox"/> Operation of electrical equipment <input type="checkbox"/> Shift change <input type="checkbox"/> Other descriptions		

WFIA0226E

A
B
C
D
E
BRC
G
H
I
J
K
L
M

Component Parts and Harness Connector Location

EFS004PN

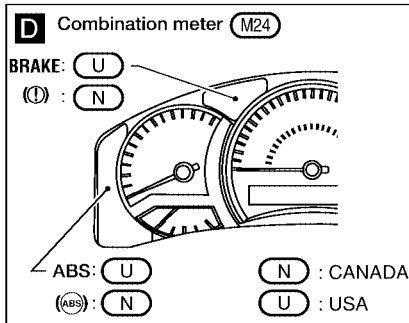
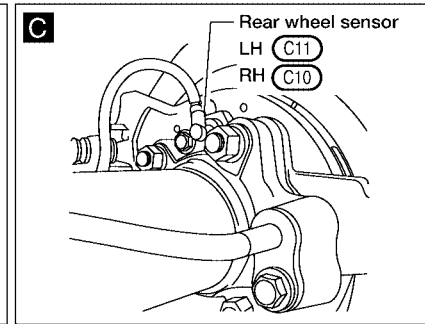
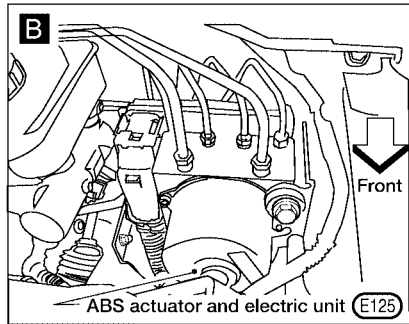
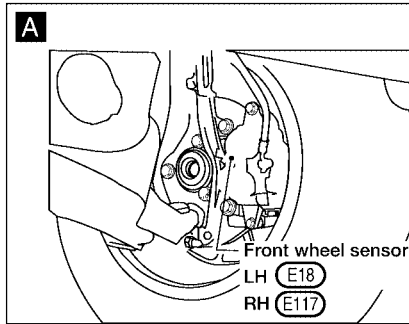
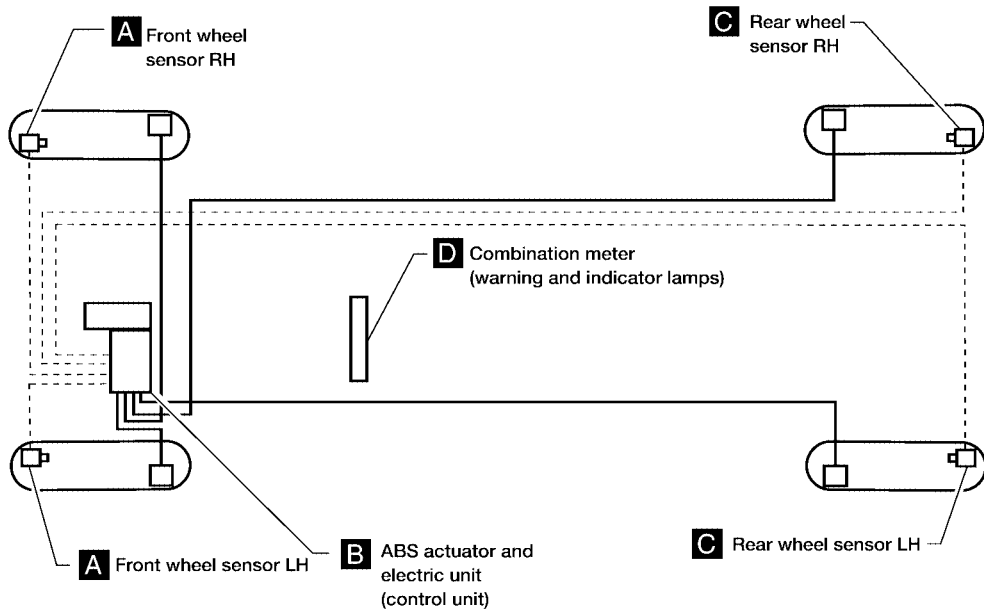

WFIA0371E

Schematic

EFS004PO

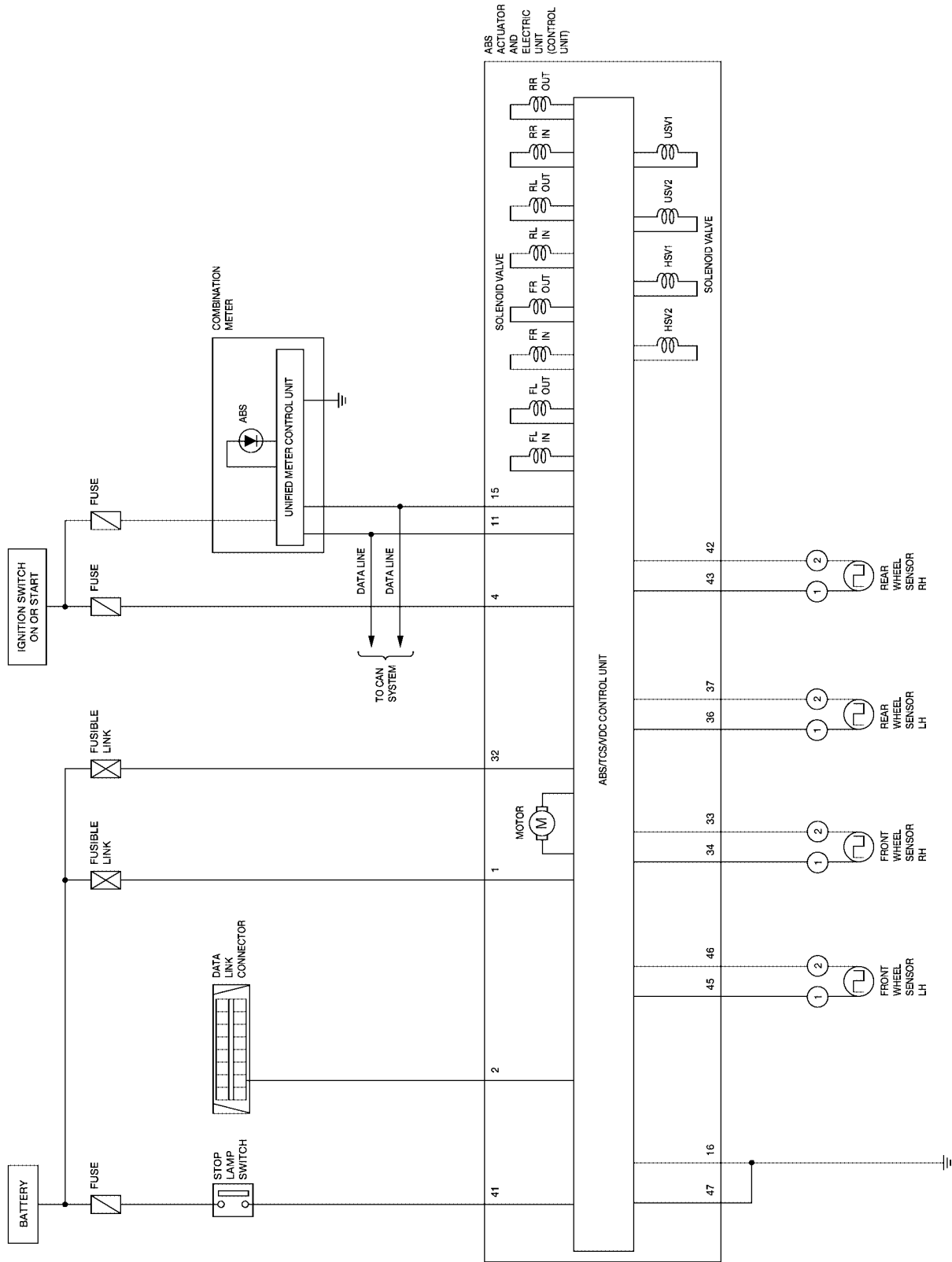

A
B
C
D
E
BRC
G
H
I
J
K
L
M

WFWA0198E

TROUBLE DIAGNOSIS

[ABS]

Wiring Diagram — ABS —

EFS004PP

BRC-ABS-01

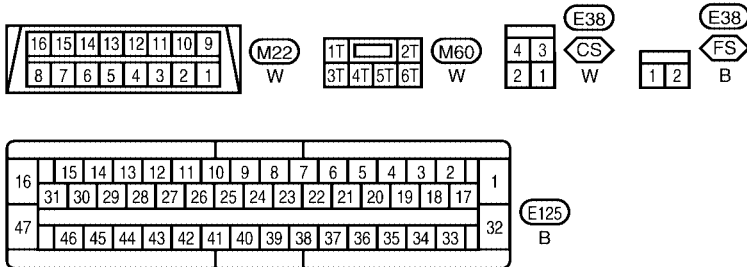
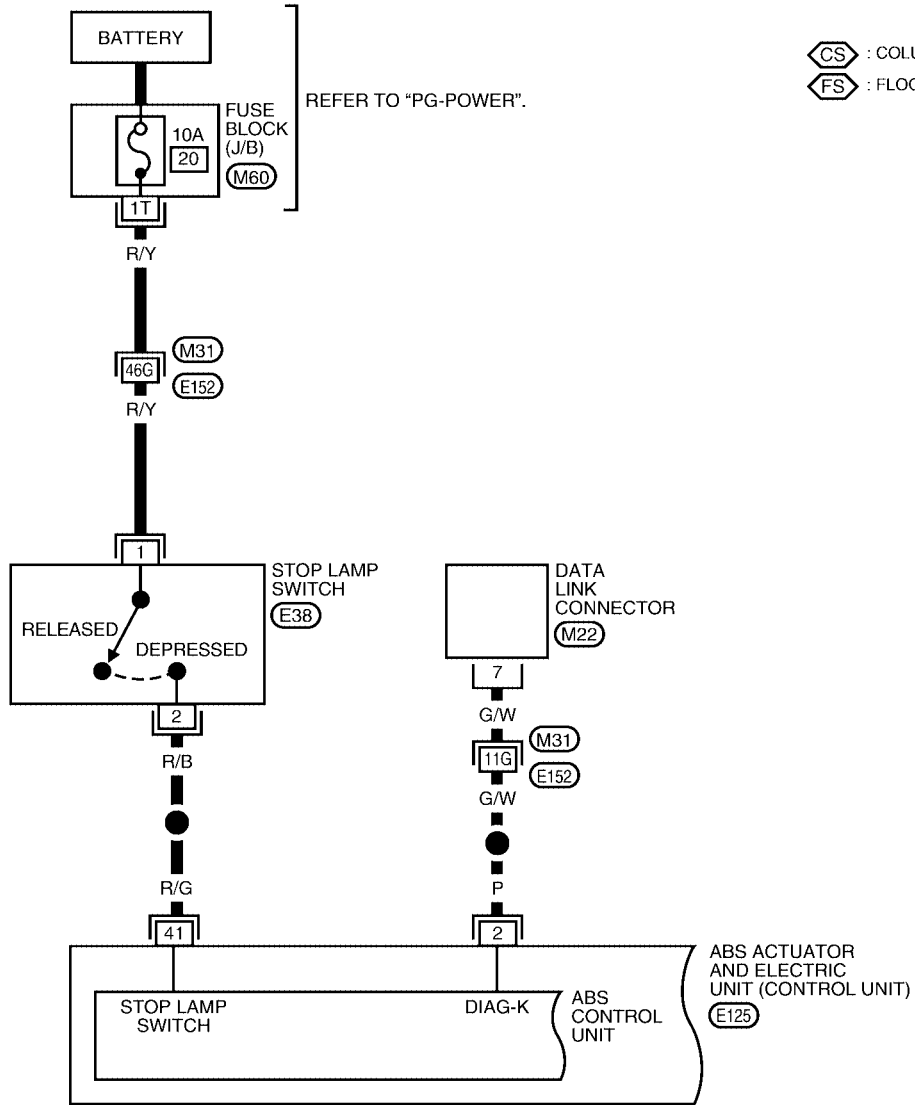

REFER TO THE FOLLOWING.
M31 - SUPER MULTIPLE JUNCTION (SMJ)

TROUBLE DIAGNOSIS

[ABS]

BRC-ABS-02

— : DATA LINE

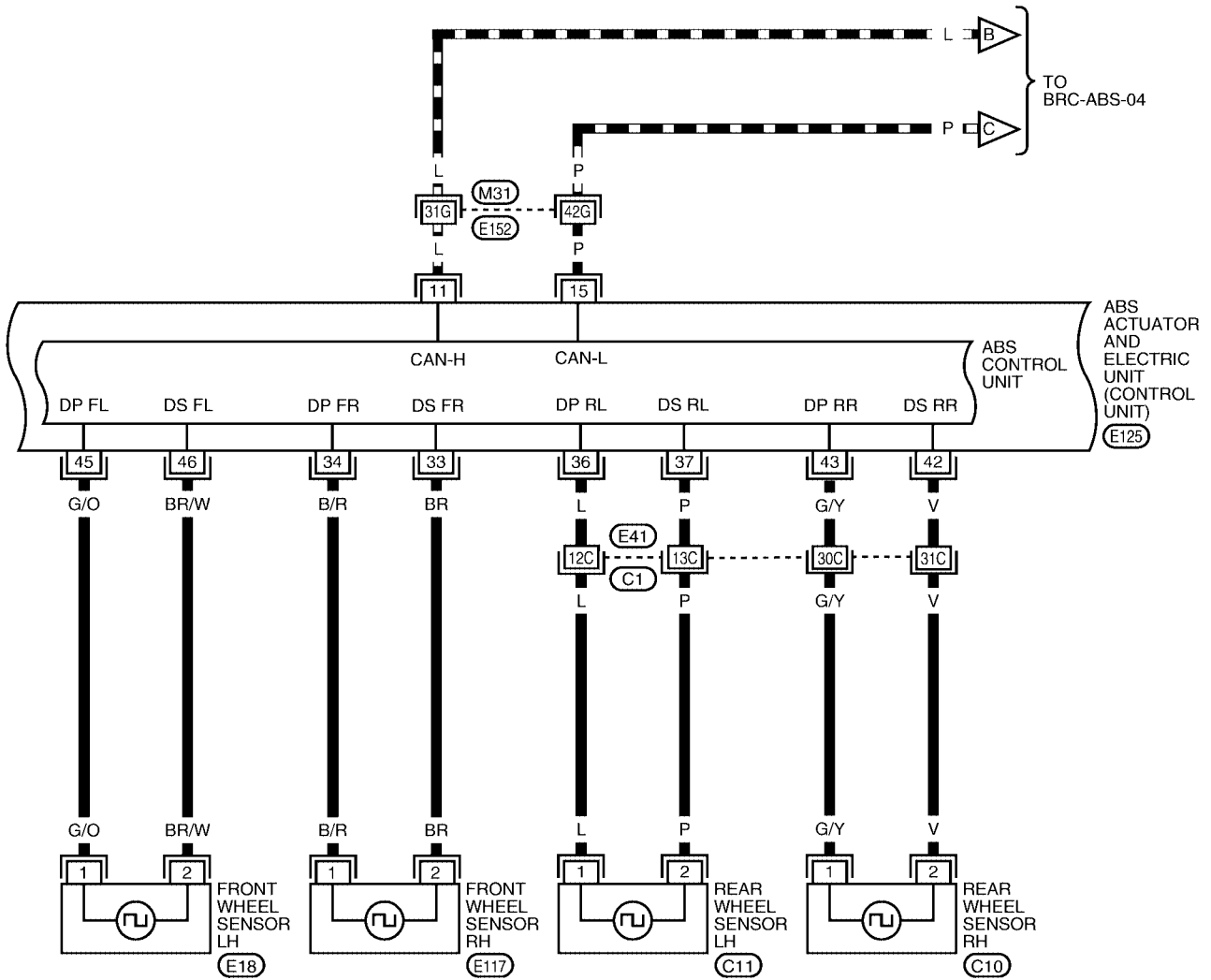

(E18), (E117), (C10), (C11)
 2 1 GR GR GR BR

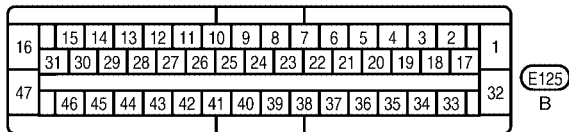

REFER TO THE FOLLOWING.
 (C1), (M31) - SUPER
 MULTIPLE JUNCTION (SMJ)

WFWA0200E

TROUBLE DIAGNOSIS

[ABS]

BRC-ABS-03

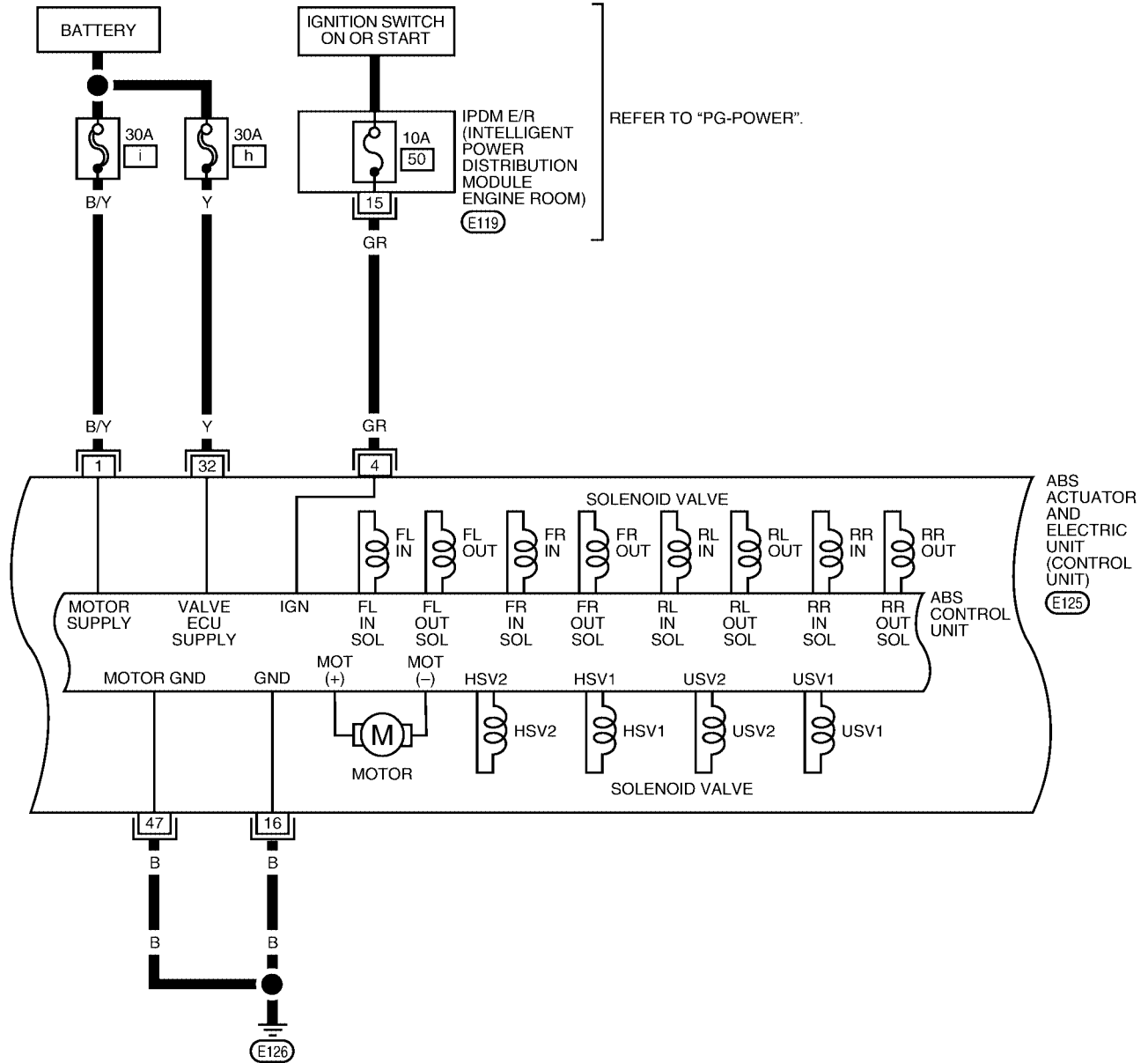

3	4	5	6	7	8	9		
10	11	12	13	14	15	16	17	18

(E119) W

16	15	14	13	12	11	10	9	8	7	6	5	4	3	2	1
31	30	29	28	27	26	25	24	23	22	21	20	19	18	17	
47	46	45	44	43	42	41	40	39	38	37	36	35	34	33	32

(E125) B

WFWA0201E

TROUBLE DIAGNOSIS

[ABS]

BRC-ABS-04

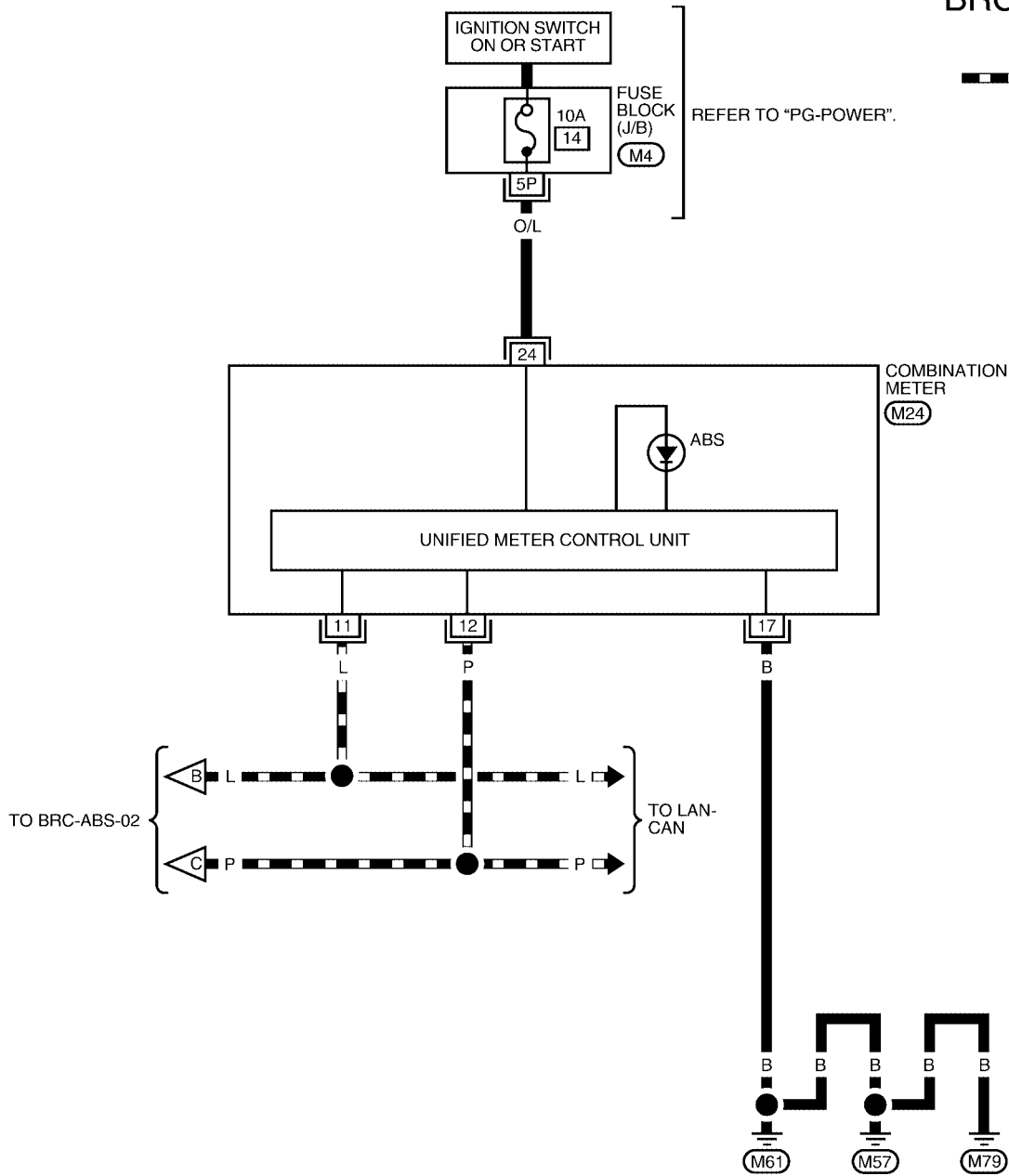

A
B
C
D
E
BRC
G
H
I
J
K
L
M

1P	2P	3P	4P	5P	6P	7P		
8P	9P	10P	11P	12P	13P	14P	15P	16P

(M4)
W

1	2	3	4	5	6	7	8	9	10	11	12	13	14	15	16	17	18	19	20
21	22	23	24	25	26	27	28	29	30	31	32	33	34	35	36	37	38	39	40

(M24)
W

WFWA0202E

Basic Inspection**BRAKE FLUID LEVEL, FLUID LEAK, AND BRAKE PAD INSPECTION**

1. Check fluid level in the brake fluid reservoir. If fluid level is low, add fluid.
2. Check the brake piping and around the ABS actuator and electric unit (control unit) for leaks. If there is leaking or seeping fluid, check the following items.
 - If ABS actuator and electric unit (control unit) connection is loose, tighten the piping to the specified torque and recheck for leaks.
 - If there is damage to the connection flare nut or ABS actuator and electric unit (control unit) threads, replace the damaged part and recheck for leaks.
 - When there is fluid leaking or seeping from a fluid connection, use a clean cloth to wipe off the fluid and recheck for leaks. If fluid is still seeping out, replace the damaged part. If the fluid is leaking at the ABS actuator and electric unit (control unit), replace the ABS actuator and electric unit (control unit) assembly.

CAUTION:

The ABS actuator and electric unit (control unit) cannot be disassembled and must be replaced as an assembly.

3. Check the brake pads for excessive wear.

POWER SYSTEM TERMINAL LOOSENESS AND BATTERY INSPECTION

Make sure the battery positive cable, negative cable and ground connection are not loose. In addition, make sure the battery is sufficiently charged.

ABS WARNING LAMP INSPECTION

1. Make sure ABS warning lamp turns on for approximately 1 second when the ignition switch is turned ON. If it does not, check CAN communications. If there are no errors with the CAN communication system, check the combination meter. Refer to [DI-5, "COMBINATION METERS"](#).
2. Make sure the lamp turns off approximately 1 second after the ignition switch is turned ON. If the lamp does not turn off, conduct self-diagnosis.
3. Make sure ABS warning lamp turns off approximately 2 seconds after the engine is started. If ABS warning lamp has not turned off 10 seconds after the engine has been started, conduct self-diagnosis of the ABS actuator and electric unit (control unit).
4. After conducting the self-diagnosis, be sure to erase the error memory. Refer to [BRC-23, "CONSULT-II Function \(ABS\)"](#).

Warning Lamp and Indicator Timing

EFS004PR

Condition	ABS warning lamp	Remarks
When the ignition switch is OFF	—	—
After the ignition switch is turned ON for approx. 1 second	×	—
After the ignition switch is turned ON for approx. 2 seconds	—	Lamp goes off approx. 2 seconds after the engine is started.
ABS malfunction	×	—
	×	When the ABS actuator and electric unit (control unit) is malfunctioning (power supply or ground malfunction).

X: ON
—: OFF

Control Unit Input/Output Signal Standard REFERENCE VALUE FROM CONSULT-II

EFS004PS

CAUTION:

The display shows the control unit calculation data, so a normal value might be displayed even in the event the output circuit (harness) is open or short circuited.

Monitor item	Display content	Data monitor		Note: Error inspection checklist
		Condition	Reference value in normal operation	
N POSI SIG	PNP switch signal ON/OFF condition	A/T shift position = N position	ON	BRC-34, "CAN Communication System Inspection"
		A/T shift position = other than N positions	OFF	
P POSI SIG	PNP switch signal ON/OFF condition	A/T shift position P position	ON	BRC-34, "CAN Communication System Inspection"
		A/T shift position = other than P positions	OFF	
GEAR	A/T gear position	1st gear	1	—
		2nd gear	2	
		3rd gear	3	
		4th gear	4	
		5th gear	5	
FR RH SENSOR FR LH SENSOR RR RH SENSOR RR LH SENSOR	Wheel speed	Vehicle stopped	0 [km/h (MPH)]	BRC-29, "Wheel Sensor System"
		Vehicle running (Note 1)	Almost in accordance with speedometer display (within ±10%)	
BATTERY VOLT	Battery voltage supplied to ABS actuator and electric unit (control unit)	Ignition switch ON	10 to 16V	BRC-33, "ABS Control Unit Power and Ground Systems Inspection"
STOP LAMP SW	Stop lamp switch operation	Brake pedal depressed	ON	—
		Brake pedal not depressed	OFF	
ABS WARN LAMP	ABS warning lamp ON condition (Note 2)	ABS warning lamp ON	ON	BRC-38, "ABS Warning Lamp Does Not Come On When Ignition Switch Is Turned On"
		ABS warning lamp OFF	OFF	
MOTOR RELAY	Operation status of motor and motor relay	Ignition switch ON or running (ABS not activated)	OFF	BRC-32, "Actuator Motor, Motor Relay, and Circuit Inspection"
		Ignition switch ON or engine running (ABS activated)	ON	

TROUBLE DIAGNOSIS

[ABS]

Monitor item	Display content	Data monitor		Note: Error inspection checklist
		Condition	Reference value in normal operation	
ACTUATOR RLY	Actuator relay operation status	Vehicle stopped (Ignition switch ON)	OFF	BRC-32, "Actuator Motor, Motor Relay, and Circuit Inspection"
		Vehicle stopped (Engine running)	ON	
FR LH IN SOL FR LH OUT SOL FR RH IN SOL FR RH OUT SOL RR RH IN SOL RR RH OUT SOL RR LH IN SOL RR LH OUT SOL	Solenoid valve operation	Actuator (solenoid) is active ("ACTIVE TEST" with CONSULT-II) or actuator relay is inactive (in fail-safe mode).	ON	BRC-31, "Solenoid Valve System Inspection"
		When actuator (solenoid) is not active and actuator relay is active (ignition switch ON).	OFF	
FLUID LEV SW	ON/OFF status of brake fluid level switch	When brake fluid level switch ON	ON	DI-30, "WARNING LAMPS"
		When brake fluid level switch OFF	OFF	
ABS SIGNAL EBD SIGNAL	Signal status	ABS active EBD active	ON	ABS system EBD system
		ABS not active EBD not active	OFF	
ABS FAIL SIG EBD FAIL SIG	Fail signal status	ABS fail EBD fail	ON	ABS system EBD system
		ABS normal EBD normal	OFF	

Note 1: Confirm tire pressure is normal.

Note 2: ON/OFF timing of ABS warning lamp

ON: For approximately 1 second after ignition switch is turned ON, or when a malfunction is detected.

OFF: Approximately 1 second after ignition switch is turned ON (when system is in normal operation).

CONSULT-II Function (ABS)

CONSULT-II can display each diagnostic item using the diagnostic test modes shown following.

ABS diagnostic mode	Description
WORK SUPPORT	Supports inspection and adjustments. Commands are transmitted to the ABS actuator and electric unit (control unit) for setting the status suitable for required operation, input/output signals are received from the ABS actuator and electric unit (control unit) and received data is displayed.
SELF-DIAG RESULTS	Displays ABS actuator and electric unit (control unit) self-diagnosis results.
DATA MONITOR	Displays ABS actuator and electric unit (control unit) input/output data in real time.
CAN DIAG SUPPORT MNTR	The result of transmit/receive diagnosis of CAN communication can be read.
ACTIVE TEST	Operation of electrical loads can be checked by sending drive signal to them.
FUNCTION TEST	Conducted by CONSULT-II instead of a technician to determine whether each system is "OK" or "NG".
ECU PART NUMBER	ABS actuator and electric unit (control unit) part number can be read.

CONSULT-II BASIC OPERATION PROCEDURE

1. Turn ignition switch OFF.
2. Connect CONSULT-II and CONSULT-II CONVERTER to the data link connector.

CAUTION:

If CONSULT-II is used with no connection of CONSULT-II CONVERTER, malfunctions might be detected in self-diagnosis depending on control unit which carries out CAN communication.

3. Turn ignition switch ON.

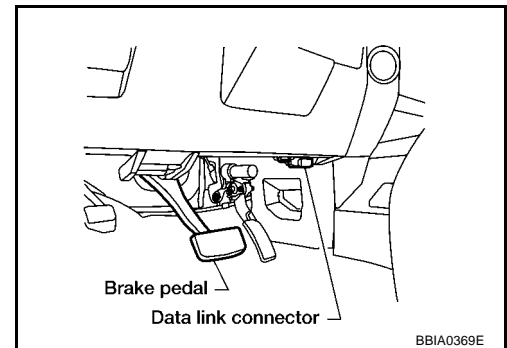

4. Touch "START (NISSAN BASED VHCL)".

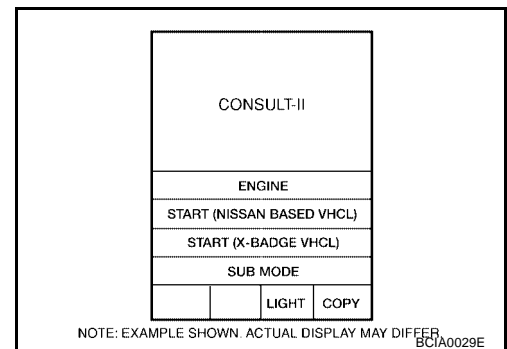

5. Touch "ABS" in the "SELECT SYSTEM" screen. If "ABS" is not indicated, go to [GI-38, "CONSULT-II Data Link Connector \(DLC\) Circuit"](#).

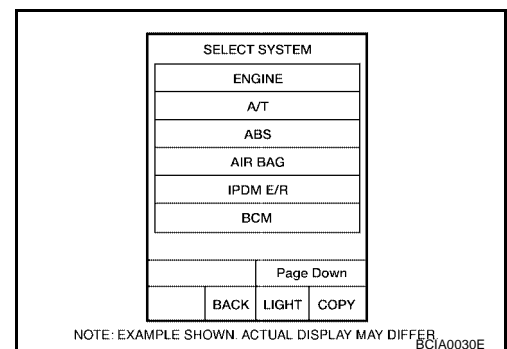

6. Select the required diagnostic location from the "SELECT DIAG MODE" screen.
For further information, see the CONSULT-II Operation Manual.

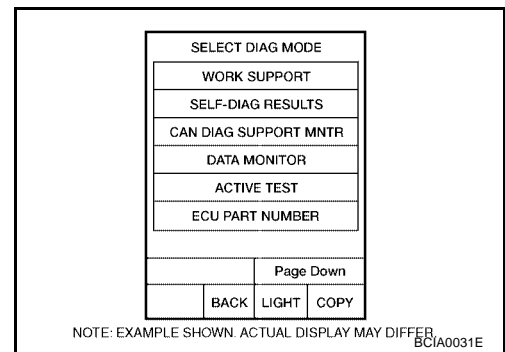

SELF-DIAGNOSIS

Description

If an error is detected in the system, the ABS warning lamp will turn on. In this case, perform self-diagnosis as follows:

Operation Procedure

1. Turn ignition switch OFF.
2. Connect CONSULT-II and CONSULT-II CONVERTER to the data link connector.

CAUTION:

If **CONSULT-II** is used with no connection of **CONSULT-II CONVERTER**, malfunctions might be detected in self-diagnosis depending on control unit which carries out **CAN** communication.

3. Turn ignition switch ON.
4. Start engine and drive at approximately 30 km/h (19 MPH) or more for approximately 1 minute.
5. After stopping the vehicle, with the engine running, touch "START (NISSAN BASED VHCL)", "ABS", "SELF-DIAG RESULTS" in order on the CONSULT-II screen.

CAUTION:

If **"START (NISSAN BASED VHCL)"** is touched immediately after starting the engine or turning on the ignition switch, **"ABS"** might not be displayed in the **SELECT SYSTEM** screen. In this case, repeat the operation from step 1.

6. The self-diagnostic results are displayed. (If necessary, the self-diagnostic results can be printed out by touching "PRINT".)
 - When "NO DTC IS DETECTED" is displayed, check the ABS warning lamp.
7. Conduct the appropriate inspection from the display item list, and repair or replace the malfunctioning component.
8. Start engine and drive at approximately 30 km/h (19 MPH) or more for approximately 1 minute.

CAUTION:

● When a wheel sensor "short-circuit" is detected, if the vehicle is not driven at 30 km/h (19 MPH) for at least 1 minute, the ABS warning lamp will not turn off even if the malfunction is repaired.

9. Turn ignition switch OFF to prepare for erasing the memory.
10. Start the engine and touch "START (NISSAN BASED VHCL)", "ABS", "SELF-DIAG RESULTS", "ERASE" in order on the CONSULT-II screen to erase the error memory.
If "ABS" is not indicated, go to [GI-38, "CONSULT-II Data Link Connector \(DLC\) Circuit"](#).

CAUTION:

If the error memory is not erased, re-conduct the operation from step 5.

11. For the final inspection, drive at approximately 30 km/h (19 MPH) or more for approximately 1 minute and confirm that the ABS warning lamp is off.

TROUBLE DIAGNOSIS

[ABS]

Display Item List

Self-diagnostic item	Malfunction detecting condition	Check system
FR LH SENSOR 1 [C1104]	Circuit of front LH wheel sensor is open, shorted or sensor power voltage is unusual.	
RR RH SENSOR 1 [C1101]	Circuit of rear RH wheel sensor is open, shorted or sensor power voltage is unusual.	
FR RH SENSOR 1 [C1103]	Circuit of front RH wheel sensor is open, shorted or sensor power voltage is unusual.	
RR LH SENSOR 1 [C1102]	Circuit of rear LH wheel sensor is open, shorted or sensor power voltage is unusual.	
FR LH SENSOR 2 [C1108]	ABS actuator and electric unit (control unit) cannot identify sensor pulses, because of large gap between wheel sensor and sensor rotor.	BRC-29. "Wheel Sensor System" (Note 1)
RR RH SENSOR 2 [C1105]	ABS actuator and electric unit (control unit) cannot identify sensor pulses, because of large gap between wheel sensor and sensor rotor.	
FR RH SENSOR 2 [C1107]	ABS actuator and electric unit (control unit) cannot identify sensor pulses, because of large gap between wheel sensor and sensor rotor.	
RR LH SENSOR 2 [C1106]	ABS actuator and electric unit (control unit) cannot identify sensor pulses, because of large gap between wheel sensor and sensor rotor.	
BATTERY VOLTAGE [ABNORMAL] [C1109]	ABS actuator and electric unit (control unit) power voltage is too low.	BRC-33. "ABS Control Unit Power and Ground Systems Inspection"
CONTROLLER FAILURE [C1110]	Internal malfunction of ABS actuator and electric unit (control unit)	BRC-30. "ABS Control Unit Inspection"
PUMP MOTOR (Note 3) [C1111]	During actuator motor operation with ON, when actuator motor turns OFF or when control line for actuator motor relay is open.	BRC-32. "Actuator Motor, Motor Relay, and Circuit Inspection"
	During actuator motor operation with OFF, when actuator motor turns ON or when control line for relay is shorted to ground.	
G-SENSOR [C1113]	G-sensor is malfunctioning.	BRC-30. "ABS Control Unit Inspection"
FR LH IN ABS SOL [C1120]	Circuit of front LH IN ABS solenoid is open or shorted, or control line is open or shorted to power supply or ground.	
FR LH OUT ABS SOL [C1121]	Circuit of front LH OUT ABS solenoid is open or shorted, or control line is open or shorted to power supply or ground.	
RR RH IN ABS SOL [C1126]	Circuit of rear RH IN ABS solenoid is open or shorted, or control line is open or shorted to power supply or ground.	
RR RH OUT ABS SOL [C1127]	Circuit of rear RH OUT ABS solenoid is open or shorted, or control line is open or shorted to power supply or ground.	
FR RH IN ABS SOL [C1122]	Circuit of front RH IN ABS solenoid is open or shorted, or control line is open or shorted to power supply or ground.	BRC-31. "Solenoid Valve System Inspection"
FR RH OUT ABS SOL [C1123]	Circuit of front RH OUT ABS solenoid is open or shorted, or control line is open or shorted to power supply or ground.	
RR LH IN ABS SOL [C1124]	Circuit of rear LH IN ABS solenoid is open or shorted, or control line is open or shorted to power supply or ground.	
RR LH OUT ABS SOL [C1125]	Circuit of rear LH OUT ABS solenoid is open or shorted, or control line is open or shorted to power supply or ground.	
REAR IN ABS SOL [C1190]	Circuit of rear IN ABS solenoid is open or shorted, or control line is open or shorted to power supply or ground.	
REAR OUT ABS SOL [C1191]	Circuit of rear OUT ABS solenoid is open or shorted, or control line is open or shorted to power supply or ground.	

A

B

C

D

E

BRC

G

H

I

J

K

L

M

TROUBLE DIAGNOSIS

[ABS]

Self-diagnostic item	Malfunction detecting condition	Check system
ACTUATOR RLY [C1140]	ABS actuator relay or circuit malfunction.	BRC-32, "Actuator Motor, Motor Relay, and Circuit Inspection"
CAN COMM CIRCUIT [U1000]	<ul style="list-style-type: none"> ● CAN communication line is open or shorted. ● ABS actuator and electric unit (control unit) internal malfunction ● Battery voltage for ECM is suddenly interrupted for approximately 0.5 second or more. 	BRC-34, "CAN Communication System Inspection" (Note 2)

Note 1. If wheel sensor 2 for each wheel is indicated, check ABS actuator and electric unit (control unit) power supply voltage in addition to wheel sensor circuit check.

Note 2. If multiple malfunctions are detected including CAN communication line [U1000], perform diagnosis for CAN communication line first.

Note 3. "ACTUATOR RLY" on the CONSULT-II self-diagnosis results indicates the malfunction of the actuator motor relay or circuit.

DATA MONITOR

Operation Procedure

1. After turning OFF the ignition switch, connect CONSULT-II and the CONSULT-II CONVERTER to the data link connector.

CAUTION:

If CONSULT-II is used with no connection of CONSULT-II CONVERTER, malfunctions might be detected in self-diagnosis depending on control unit which carries out CAN communication.

2. Touch "START (NISSAN BASED VHCL)", "ABS", "DATA MONITOR" in order on the CONSULT-II screen. If "ABS" is not indicated, go to [GI-38, "CONSULT-II Data Link Connector \(DLC\) Circuit"](#).

CAUTION:

When "START (NISSAN BASED VHCL)" is touched immediately after starting the engine or turning on the ignition switch, "ABS" might not be displayed in the SELECT SYSTEM screen. In this case, repeat the operation from step 2.

3. Return to the SELECT MONITOR ITEM screen, and touch "ECU INPUT SIGNALS", "MAIN SIGNALS" or "SELECTION FROM MENU". Refer to the following information.
4. When "START" is touched, the data monitor screen is displayed.

Display Item List

Item (Unit)	Data monitor item selection			Remarks
	ECU INPUT SIGNALS	MAIN SIGNALS	SELECTION FROM MENU	
FR RH SENSOR (km/h, MPH)	×	×	×	Wheel speed calculated by front RH wheel sensor signal is displayed.
FR LH SENSOR (km/h, MPH)	×	×	×	Wheel speed calculated by front LH wheel sensor signal is displayed.
RR RH SENSOR (km/h, MPH)	×	×	×	Wheel speed calculated by rear RH wheel sensor signal is displayed.
RR LH SENSOR (km/h, MPH)	×	×	×	Wheel speed calculated by rear LH wheel sensor signal is displayed.
BATTERY VOLT (V)	×	×	×	Voltage supplied to ABS actuator and electric unit (control unit) is displayed.
STOP LAMP SW (ON/OFF)	×	×	×	Stop lamp switch (ON/OFF) status is displayed.
ABS WARN LAMP (ON/OFF)	—	×	×	ABS warning lamp (ON/OFF) status is displayed.
FR LH IN SOL (ON/OFF)	—	×	×	Front LH IN ABS solenoid (ON/OFF) status is displayed.
FR LH OUT SOL (ON/OFF)	—	×	×	Front LH OUT ABS solenoid (ON/OFF) status is displayed.

TROUBLE DIAGNOSIS

[ABS]

Item (Unit)	Data monitor item selection			Remarks
	ECU INPUT SIGNALS	MAIN SIGNALS	SELECTION FROM MENU	
RR RH IN SOL (ON/OFF)	–	×	×	Rear RH IN ABS solenoid (ON/OFF) status is displayed.
RR RH OUT SOL (ON/OFF)	–	×	×	Rear RH OUT ABS solenoid (ON/OFF) status is displayed.
FR RH IN SOL (ON/OFF)	–	×	×	Front RH IN ABS solenoid (ON/OFF) status is displayed.
FR RH OUT SOL (ON/OFF)	–	×	×	Front RH OUT ABS solenoid (ON/OFF) status is displayed.
RR LH IN SOL (ON/OFF)	–	×	×	Rear LH IN ABS solenoid (ON/OFF) status is displayed.
RR LH OUT SOL (ON/OFF)	–	×	×	Rear LH OUT ABS solenoid (ON/OFF) status is displayed.
MOTOR RELAY (ON/OFF)	–	×	×	ABS motor relay signal (ON/OFF) status is displayed.
ACTUATOR RLY (ON/OFF)	–	×	×	ABS actuator relay signal (ON/OFF) status is displayed.
ABS FAIL SIG (ON/OFF)	–	–	×	ABS fail signal (ON/OFF) status is displayed.
EBD FAIL SIG (ON/OFF)	–	–	×	EBD fail signal (ON/OFF) status is displayed.
FLUID LEV SW (ON/OFF)	×	–	×	Brake fluid level switch (ON/OFF) status is displayed.
EBD SIGNAL (ON/OFF)	–	–	×	EBD operation (ON/OFF) status is displayed.
ABS SIGNAL (ON/OFF)	–	–	×	ABS operation (ON/OFF) status is displayed.

×: Applicable

–: Not applicable

ACTIVE TEST

CAUTION:

- Do not perform active test while driving.
- Make sure to completely bleed air from the brake system.
- The ABS and brake warning lamps turn on during the active test.

Operation Procedure

1. Connect the CONSULT-II and CONSULT-II CONVERTER to the data link connector and start the engine.

CAUTION:

If CONSULT-II is used with no connection of CONSULT-II CONVERTER, malfunctions might be detected in self-diagnosis depending on control unit which carries out CAN communication.

2. Touch "START (NISSAN BASED VHCL)" on the display screen.
3. Touch "ABS".
If "ABS" is not indicated, go to [GI-38, "CONSULT-II Data Link Connector \(DLC\) Circuit"](#).
4. Touch "ACTIVE TEST".

TROUBLE DIAGNOSIS

[ABS]

5. The SELECT TEST ITEM screen is displayed.
6. Touch necessary test item.

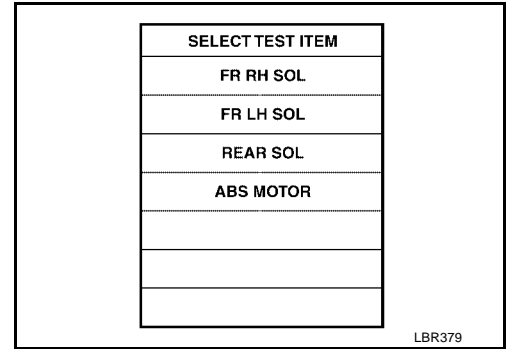

7. With the "MAIN SIGNALS" display selected, touch "START".
8. The Active Test screen will be displayed, so conduct the following test.

Solenoid Valve Operation Chart

Operation		ABS solenoid valve			ABS solenoid valve (ACT)		
		UP	KEEP	DOWN	UP	ACTUA-TOR UP	ACTUA-TOR KEEP
FR RH SOL FR RH ABS SOLE- NOID (ACT)	FR RH IN SOL	OFF	ON	ON	OFF	OFF	OFF
	FR RH OUT SOL	OFF	OFF	ON*	OFF	OFF	OFF
FR LH SOL FR LH ABS SOLE- NOID (ACT)	FR LH IN SOL	OFF	ON	ON	OFF	OFF	OFF
	FR LH OUT SOL	OFF	OFF	ON*	OFF	OFF	OFF
RR RH SOL RR RH ABS SOLE- NOID (ACT)	RR RH IN SOL	OFF	ON	ON	OFF	OFF	OFF
	RR RH OUT SOL	OFF	OFF	ON*	OFF	OFF	OFF
RR LH SOL RR LH ABS SOLE- NOID (ACT)	RR LH IN SOL	OFF	ON	ON	OFF	OFF	OFF
	RR LH OUT SOL	OFF	OFF	ON*	OFF	OFF	OFF
REAR SOL	RR RH IN SOL	OFF	ON	ON	OFF	OFF	OFF
	RR RH OUT SOL	OFF	OFF	ON*	OFF	OFF	OFF
	RR LH IN SOL	OFF	ON	ON	OFF	OFF	OFF
	RR LH OUT SOL	OFF	OFF	ON*	OFF	OFF	OFF

*: ON for 1 to 2 seconds after the touch, and then OFF

NOTE:

- If active test is performed with brake pedal depressed, pedal stroke may change. This is normal.
- "TEST IS STOPPED" is displayed approximately 10 seconds after operation starts.
- After "TEST IS STOPPED" is displayed, to perform test again, repeat Step 6.

ABS Motor

Touch "ON" and "OFF" on the screen. Check that ABS motor relay operates as shown in table below.

Operation	ON	OFF
ABS actuator relay	ON	ON
ABS motor relay	ON	OFF

NOTE:

- If active test is performed with brake pedal depressed, pedal stroke may change. This is normal.
- "TEST IS STOPPED" is displayed approximately 10 seconds after operation starts.

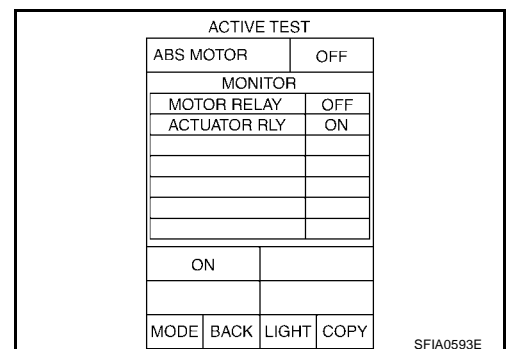

TROUBLE DIAGNOSIS FOR SELF-DIAGNOSTIC ITEMS**Wheel Sensor System**

INSPECTION PROCEDURE

1. CONNECTOR INSPECTION

Disconnect the ABS actuator and electric unit (control unit) connector E125 and wheel sensor of malfunctioning code.

Check the terminals for deformation, disconnection, looseness or damage.

OK or NG

OK >> GO TO 2.

NG >> Repair or replace as necessary. [BRC-41, "Removal and Installation"](#)

2. CHECK WHEEL SENSOR OUTPUT SIGNAL

1. Connect ABS active wheel sensor tester (J-45741) to wheel sensor using appropriate adapter.

2. Turn on the ABS active wheel sensor tester power switch.

NOTE:

The green POWER indicator should illuminate. If the POWER indicator does not illuminate, replace the battery in the ABS active wheel sensor tester before proceeding.

3. Spin the wheel of the vehicle by hand and observe the red SENSOR indicator on the ABS active wheel sensor tester. The red SENSOR indicator should flash on and off to indicate an output signal.

NOTE:

If the red SENSOR indicator illuminates but does not flash, reverse the polarity of the tester leads and retest.

Does the ABS active wheel sensor tester detect a signal?

YES >> GO TO 3.

NO >> Replace the wheel sensor. Refer to [BRC-39, "Removal and Installation"](#).

3. CHECK TIRES

Check for inflation pressure, wear and size of each tire.

Are tire pressure and size correct and is tire wear within specifications?

YES >> GO TO 4.

NO >> Adjust tire pressure or replace tire(s).

4. CHECK WHEEL BEARINGS

Check wheel bearing axial end play. Refer to [FAX-5, "WHEEL BEARING INSPECTION"](#) or [RAX-5, "WHEEL BEARING INSPECTION"](#).

OK or NG

OK >> GO TO 5.

NG >> Repair or replace as necessary. Refer to [RAX-6, "Removal and Installation"](#) or [FAX-5, "Removal and Installation"](#).

5. CHECK WIRING HARNESS FOR SHORT CIRCUIT

1. Disconnect ABS actuator and electric unit (control unit) connector and wheel sensor connector of malfunction code No.

2. Check resistance between wheel sensor harness connector terminals and ground.

Continuity should not exist.

OK or NG

OK >> GO TO 6.

NG >> Repair the circuit.

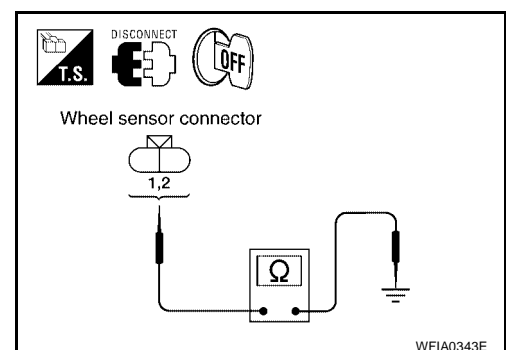

TROUBLE DIAGNOSIS FOR SELF-DIAGNOSTIC ITEMS

[ABS]

6. CHECK WIRING HARNESS FOR OPEN CIRCUIT

Check continuity between ABS actuator and electric unit (control unit) harness connector and wheel sensor harness connector.

Wheel sensor	ABS actuator and electric unit (control unit)		Wheel sensor		Continuity
	Connector - terminal	Wire color	Connector - terminal	Wire color	
Front LH	E125 - 45	G/O	E18 - 1	G/O	Yes
	E125 - 46	BR/W	E18 - 2	BR/W	
Front RH	E125 - 34	B/R	E117 - 1	B/R	
	E125 - 33	BR	E117 - 2	BR	
Rear LH	E125 - 37	P	C11 - 2	P	
	E125 - 36	L	C11 - 1	L	
Rear RH	E125 - 42	V	C10 - 2	V	
	E125 - 43	G/Y	C10 - 1	G/Y	

Continuity should exist.

OK or NG

OK >> Replace the ABS actuator and electric unit (control unit). Refer to [BRC-41, "Removal and Installation"](#).

NG >> Repair the circuit.

ABS Control Unit Inspection

EFS004PW

INSPECTION PROCEDURE

1. SELF-DIAGNOSIS RESULT CHECK

Check self-diagnosis results.

Self-diagnosis results
CONTROLLER FAILURE
G-SENSOR

Is the above displayed in the self-diagnosis display items?

YES >> Replace ABS actuator and electric unit (control unit). Refer to [BRC-41, "Removal and Installation"](#).

NO >> Inspection End.

Solenoid Valve System Inspection

INSPECTION PROCEDURE

1. SELF-DIAGNOSIS RESULT CHECK

Check self-diagnosis results.

Self-diagnosis results
FR LH IN ABS SOL
FR LH OUT ABS SOL
RR RH IN ABS SOL
RR RH OUT ABS SOL
FR RH IN ABS SOL
FR RH OUT ABS SOL
RR LH IN ABS SOL
RR LH OUT ABS SOL
REAR IN ABS SOL
REAR OUT ABS SOL

Is the above displayed in the self-diagnosis display items?

- YES >> GO TO 2.
- NO >> Inspection End.

2. CONNECTOR INSPECTION

1. Disconnect ABS actuator and electric unit (control unit) connector E125.
2. Check the terminals for deformation, disconnection, looseness or damage.

OK or NG

- OK >> GO TO 3.
- NG >> Repair or replace as necessary.

A
B
C
D
E
BRC
G
H
I
J
K
L
M

3. CHECKING SOLENOID POWER AND GROUND

1. Check voltage between ABS actuator and electric unit (control unit) harness connector E125 and body ground.

ABS actuator and electric unit (control unit) harness connector E125	Body ground	Measured value (Approx.)
32 (Y)	—	12V

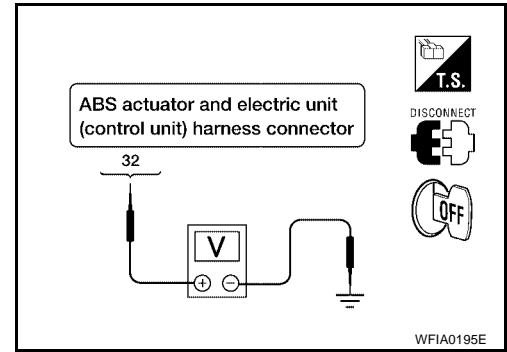

2. Check resistance between ABS actuator and electric unit (control unit) harness connector E125 and body ground.

ABS actuator and electric unit (control unit) harness connector E125	Body ground	Measured value Ω (Approx.)
16 (B)	—	0Ω
47 (B)	—	0Ω

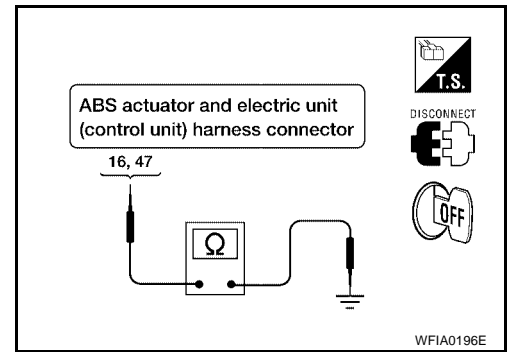

OK or NG

OK >> Perform self-diagnosis again. If the same results appear, replace ABS actuator and electric unit (control unit). Refer to [BRC-41, "Removal and Installation"](#).

NG >> Repair the circuit.

Actuator Motor, Motor Relay, and Circuit Inspection

EF5004PY

INSPECTION PROCEDURE

1. CHECKING SELF-DIAGNOSIS RESULTS

Check self-diagnosis results.

Self-diagnosis results
PUMP MOTOR
ACTUATOR RLY

Is the above displayed in the self-diagnosis display items?

YES >> GO TO 2.

NO >> Inspection End.

2. CONNECTOR INSPECTION

1. Disconnect ABS actuator and electric unit (control unit) connector E125.
2. Check the terminals for deformation, disconnection, looseness or damage.

OK or NG

OK >> GO TO 3.

NG >> Repair or replace as necessary.

3. CHECKING ABS MOTOR AND MOTOR RELAY POWER SYSTEM

1. Check voltage between ABS actuator and electric unit (control unit) harness connector E125 and ground.

ABS actuator and electric unit (control unit) harness connector E125	Body ground	Measured value (Approx.)
1 (B/Y)	—	12V

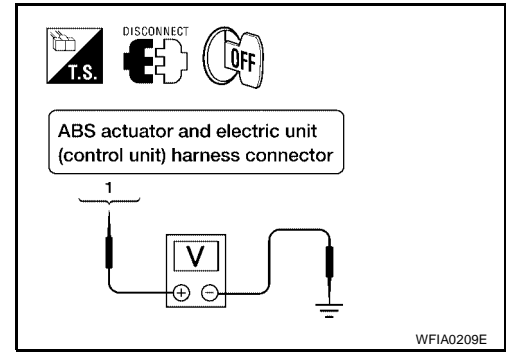

2. Check resistance between ABS actuator and electric unit (control unit) connector E125 and ground.

ABS actuator and electric unit (control unit) harness connector E125	Body ground	Measured value (Approx.)
16 (B)	—	0Ω
47 (B)	—	0Ω

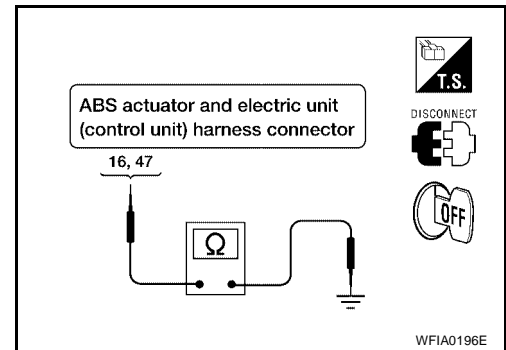

OK or NG

- OK >> Perform self-diagnosis again. If the same results appear, replace ABS actuator and electric unit (control unit). Refer to [BRC-41, "Removal and Installation"](#).
- NG >> Repair the circuit.

ABS Control Unit Power and Ground Systems Inspection

EFS00400

INSPECTION PROCEDURE

1. SELF-DIAGNOSIS RESULT CHECK

Check self-diagnosis results.

Self-diagnosis results
BATTERY VOLTAGE

Is the above displayed in the self-diagnosis display items?

- YES >> GO TO 2.
- NO >> Inspection End.

2. CONNECTOR INSPECTION

1. Disconnect the ABS actuator and electric unit (control unit) connector E125.
2. Check the terminals for deformation, disconnection, looseness or damage.

OK or NG

- OK >> GO TO 3.
- NG >> Repair or replace as necessary.

A
B
C
D
E
BRC
G
H
I
J
K
L
M

3. ABS CONTROL UNIT POWER AND GROUND CIRCUIT INSPECTION

Measure the voltage and continuity between the ABS actuator and electric unit (control unit) harness connector E125 and ground.

Signal name	ABS actuator and electric unit (control unit) harness connector E125	Body ground	Measured value
Power supply	1 (B/Y)	—	Battery voltage (Approx. 12V)
	32 (Y)		
Ground	16 (B)	—	Continuity should exist.
	47 (B)		

OK or NG

- OK >> Check the battery for loose terminals, low voltage, etc. Repair as necessary.
- NG >> Repair the circuit.

CAN Communication System Inspection

EFS004Q1

INSPECTION PROCEDURE

1. CHECK CONNECTOR

1. Turn ignition switch OFF, disconnect the ABS actuator and electric unit (control unit) connector and check the terminals for deformation, disconnection, looseness, and so on. If there is a malfunction, repair or replace the terminal.
2. Reconnect connector to perform self-diagnosis.

Is "CAN COMM CIRCUIT" displayed in self-diagnosis display items?

- YES >> Print out the self-diagnostic results, and refer to [LAN-7, "CAN COMMUNICATION"](#) .
- NO >> Connector terminal is loose, damaged, open, or shorted.

TROUBLE DIAGNOSES FOR SYMPTOMS

PFP:99999

ABS Works Frequently

EFS005FE

1. CHECK WARNING LAMP ACTIVATION

Make sure warning lamp remains off while driving.

OK or NG

OK >> GO TO 2.

NG >> Carry out self-diagnosis. Refer to [BRC-24, "SELF-DIAGNOSIS"](#) .

2. CHECK WHEEL SENSORS

Check the following.

- Wheel sensor mounting for looseness
- Wheel sensors for physical damage
- Wheel sensor connectors for terminal damage or loose connections
- Sensor rotor and mount for physical damage (rear only)

OK or NG

OK >> GO TO 3.

NG >> Repair or replace as necessary.

3. CHECK FRONT AND REAR AXLES

Check front and rear axles for excessive looseness. Refer to [FAX-5, "WHEEL BEARING INSPECTION"](#) or [RAX-5, "WHEEL BEARING INSPECTION"](#) .

OK or NG

OK >> GO TO 4.

NG >> Repair as necessary.

4. CHECK BRAKE FLUID PRESSURE

Check brake fluid pressure distribution.

Refer to [BRC-20, "Basic Inspection"](#) .

Is brake fluid pressure distribution normal?

YES >> Inspection End.

NO >> Perform Basic Inspection. Refer to [BRC-20, "Basic Inspection"](#) .

A

B

C

D

E

BRC

G

H

I

J

K

L

M

Unexpected Pedal Action

1. CHECK WARNING LAMP ACTIVATION

Make sure warning lamp remains off while driving.

OK or NG

OK >> GO TO 2.

NG >> Carry out self-diagnosis. Refer to [BRC-24, "SELF-DIAGNOSIS"](#) .

2. CHECK BRAKE PEDAL STROKE

Check brake pedal stroke.

Is pedal stroke excessive?

YES >> Perform Basic Inspection. Refer to [BRC-20, "Basic Inspection"](#) .

NO >> GO TO 3.

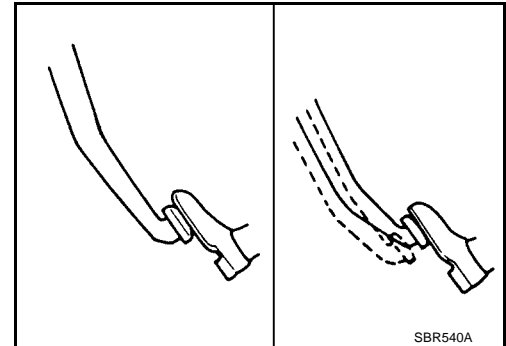

3. CHECK CONNECTOR AND BRAKING PERFORMANCE

1. Disable ABS by disconnecting ABS actuator and electric unit (control unit) connector.

2. Drive vehicle and check brake operation.

NOTE:

- Stopping distance may be longer than vehicles without ABS when road condition is slippery.
- Driving the vehicle with the ABS actuator and electric unit (control unit) disconnected may induce DTCs in electrical control units using CAN communication. After the inspection, clear all DTCs. Refer to [LAN-7, "CAN COMMUNICATION"](#) .

OK or NG

OK >> GO TO 4.

NG >> Perform Basic Inspection. Refer to [BRC-20, "Basic Inspection"](#) .

4. CHECK WHEEL SENSORS

Check the following.

- Wheel sensor mounting for looseness
- Wheel sensors for physical damage
- Wheel sensor connectors for terminal damage or loose connections

OK or NG

OK >> Check ABS actuator and electric unit (control unit) connector terminals for deformation, disconnection, looseness or damage. Reconnect ABS actuator and electric unit (control unit) harness connector. Then retest.

NG >> Repair or replace as necessary.

Long Stopping Distance

EFS005FG

1. CHECK BASE BRAKING SYSTEM PERFORMANCE

1. Disable ABS by disconnecting ABS actuator and electric unit (control unit) connector.
2. Drive vehicle and check brake operation.

NOTE:

- Stopping distance may be longer than vehicles without ABS when road condition is slippery.
- Driving the vehicle with the ABS actuator and electric unit (control unit) disconnected may induce DTCs in electrical control units using CAN communication. After the inspection, clear all DTCs. Refer to [LAN-7, "CAN COMMUNICATION"](#).

OK or NG

- OK >> Go to [BRC-35, "ABS Works Frequently"](#).
- NG >> Perform Basic Inspection. Refer to [BRC-20, "Basic Inspection"](#).

ABS Does Not Work

EFS005FH

CAUTION:

The ABS does not operate when the vehicle speed is 10 km/h (6 MPH) or less.

1. CHECK WARNING LAMP ACTIVATION

Turn ignition switch ON and check for warning lamp activation.

- Warning lamp should activate for approximately 2 seconds after turning the ignition switch ON.

OK or NG

- OK >> Carry out self-diagnosis. Refer to [BRC-24, "SELF-DIAGNOSIS"](#).
- NG >> Go to [BRC-38, "ABS Warning Lamp Does Not Come On When Ignition Switch Is Turned On"](#).

Pedal Vibration or ABS Operation Noise

EFS005FI

NOTE:

During ABS activation, pedal vibration may be felt and a noise may be heard. This is normal and does not indicate a malfunction.

1. CHECK SYMPTOM

1. Apply brake.
2. Start engine.

Does the symptom occur only when engine is started?

- YES >> Carry out self-diagnosis. Refer to [BRC-24, "SELF-DIAGNOSIS"](#).
- NO >> GO TO 2.

2. RECHECK SYMPTOM

Does the symptom occur only when electrical equipment switches (such as headlamps) are turned on?

- YES >> Check for radio, antenna or related wiring that is routed too close to the ABS actuator and electric unit (control unit) and reroute as necessary.
- NO >> Go to [BRC-35, "ABS Works Frequently"](#).

ABS Warning Lamp Does Not Come On When Ignition Switch Is Turned On EFS005FJ

1. CHECK ABS ACTUATOR AND ELECTRIC UNIT (CONTROL UNIT) FUSES

Check 30A fusible link **h** and 30A fusible link **i** for ABS actuator and electric unit (control unit). For fusible link layout, refer to [PG-4, "POWER SUPPLY ROUTING CIRCUIT"](#).

OK or NG

OK >> GO TO 2.

NG >> If fusible link is blown, be sure to eliminate cause of problem before replacing.

2. CHECK ABS ACTUATOR AND ELECTRIC UNIT (CONTROL UNIT) POWER SUPPLY CIRCUITS

1. Disconnect ABS actuator and electric unit (control unit) connector.
2. Check voltage between ABS actuator and electric unit (control unit) connector terminal 1 (B/Y) and ground and terminal 32 (Y) and ground.

Does battery voltage exist?

YES >> GO TO 3.

NO >> Repair harness or connectors between fusible link and ABS actuator and electric unit (control unit).

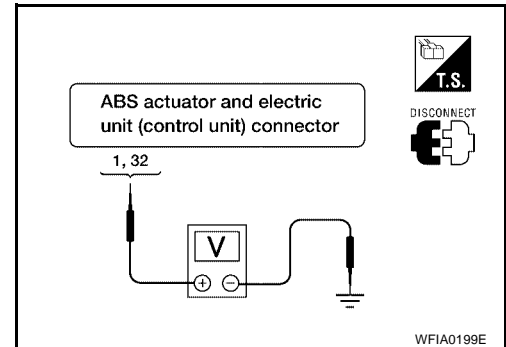

3. CHECK ABS ACTUATOR AND ELECTRIC UNIT (CONTROL UNIT) GROUND CIRCUIT

Check continuity between ABS actuator and electric unit (control unit) connector terminal 16 (B) and ground and terminal 47 (B) and ground.

Does continuity exist?

YES >> Replace ABS actuator and electric unit (control unit). Refer to [BRC-41, "Removal and Installation"](#).

NO >> Repair harness or connectors between ABS actuator and electric unit (control unit) and ground.

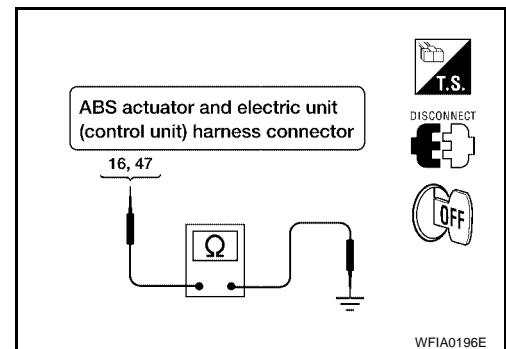

ABS Warning Lamp Stays On When Ignition Switch Is Turned On EFS005FK

1. CARRY OUT SELF-DIAGNOSIS

Carry out self-diagnosis. Refer to [BRC-24, "SELF-DIAGNOSIS"](#).

Are malfunctions detected in self-diagnosis?

YES >> Refer to [BRC-25, "Display Item List"](#).

NO >> Refer to [DI-30, "WARNING LAMPS"](#).

WHEEL SENSORS

Removal and Installation

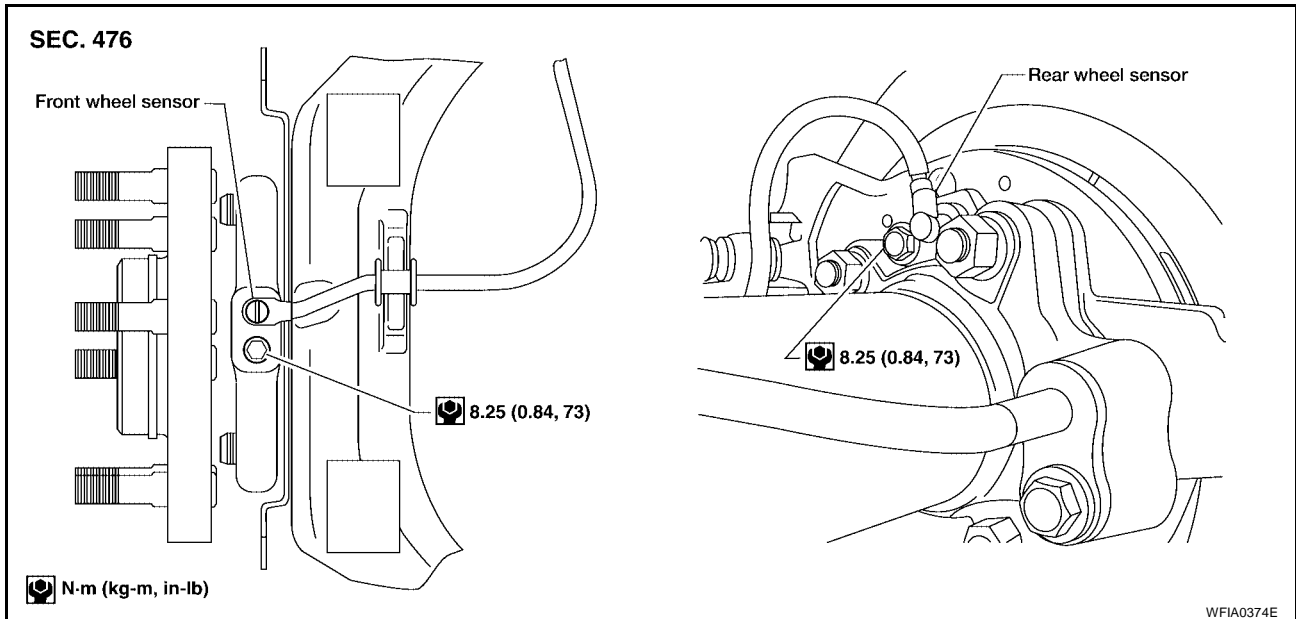

REMOVAL

1. Remove wheel sensor mounting screw.
 - When removing the front wheel sensor, first remove the disc rotor to gain access to the front wheel sensor mounting bolt. Refer to [BR-24, "Removal and Installation of Brake Caliper and Disc Rotor"](#).
2. Pull out the sensor, being careful to turn it as little as possible.

CAUTION:

 - Be careful not to damage sensor edge and sensor rotor teeth.
 - Do not pull on the sensor harness.
3. Disconnect wheel sensor harness electrical connector, then remove harness from mounts.

INSTALLATION

Before installing wheel sensors,

- Inspect wheel sensor O-ring, replace sensor assembly if damaged.
- Clean wheel sensor hole and mounting surface with brake cleaner and a lint-free shop rag. Be careful that dirt and debris do not enter the axle.
- Apply a coat of suitable grease to the wheel sensor O-ring and mounting hole.

Installation is in the reverse order of removal.

A

B

C

D

E

BRC

G

H

I

J

K

L

M

SENSOR ROTOR**Removal and Installation**
FRONT

The wheel sensor rotors are built into the wheel hubs and are not removable. If damaged, replace wheel hub and bearing assembly. Refer to [FAX-5, "Removal and Installation"](#) .

REAR**Removal**

1. Remove axle shaft assembly. Refer to [RAX-6, "Removal and Installation"](#) .

NOTE:

It is necessary to disassemble the rear axle to replace the sensor rotor.

2. Pull the sensor rotor of off the axle shaft using Tool and a press.

Tool number : 205-D002 (—)

Installation

1. Install new sensor rotor on axle shaft using a suitable length steel tube and a press. Make sure sensor rotor is fully seated.

CAUTION:

Do not reuse the old sensor rotor.

2. Install axle shaft assembly. Refer to [RAX-6, "Removal and Installation"](#) .

CAUTION:

Do not reuse the axle oil seal. The axle oil seal must be replaced every time the axle shaft assembly is removed from the axle shaft housing.

ACTUATOR AND ELECTRIC UNIT (ASSEMBLY)

PFP:47660

Removal and Installation

EFS004QB

SEC. 476

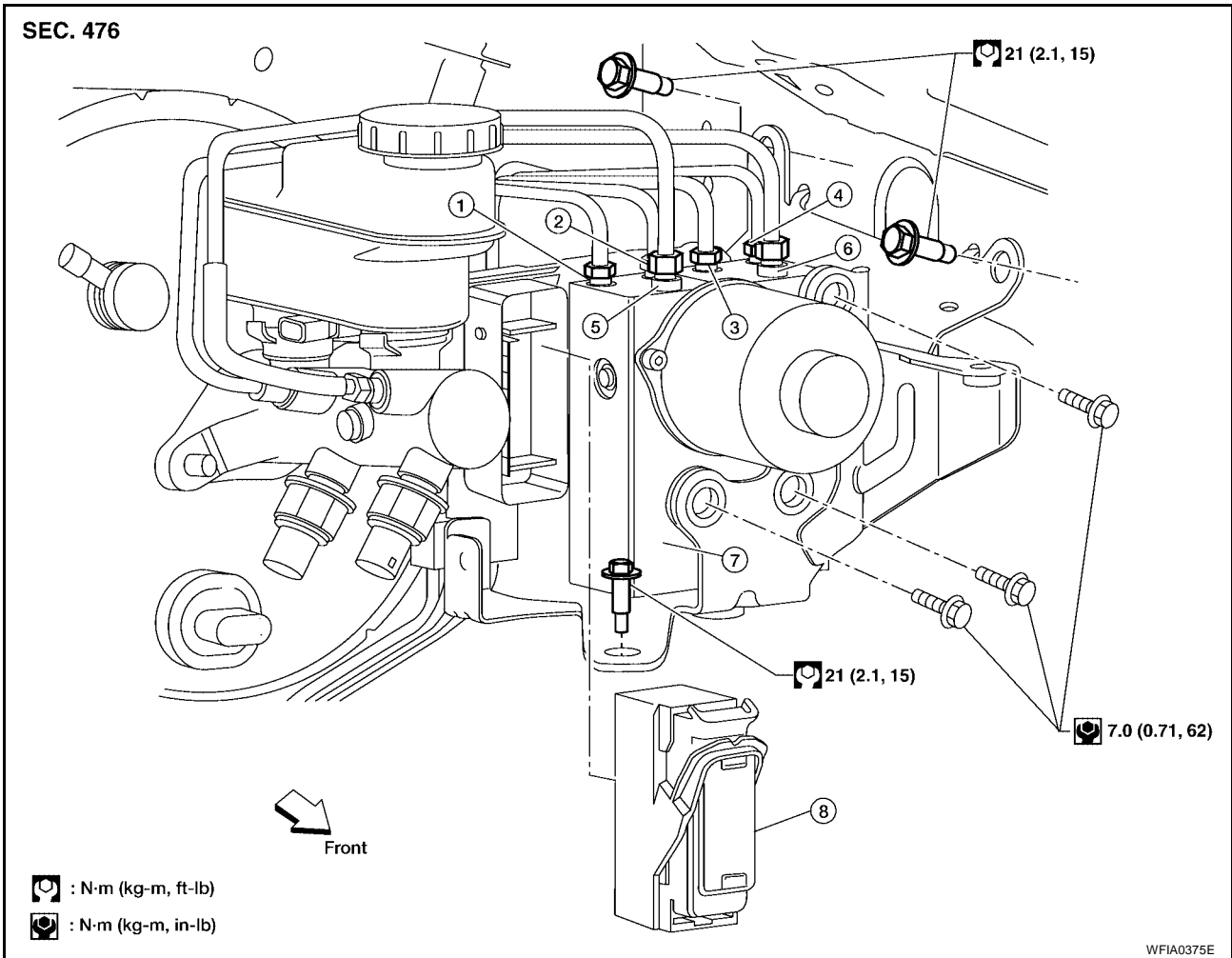

- | | | |
|--|--|--|
| 1. To rear left | 2. To rear right | 3. To front left |
| 4. To front right | 5. From the master cylinder secondary side | 6. From the master cylinder primary side |
| 7. ABS actuator and electric unit (control unit) | 8. Harness connector | |

REMOVAL

1. Disconnect the negative battery terminal.
2. Remove the cowl top extension. Refer to [EI-21, "Removal and Installation"](#).
3. Drain the brake fluid. Refer to [BR-10, "Drain and Refill"](#).
4. Disconnect the actuator harness from the ABS actuator and electric unit (control unit).

CAUTION:

- To remove the brake tubes, use a flare nut wrench to prevent the flare nuts and brake tubes from being damaged.
- Be careful not to splash brake fluid on painted areas.

5. Disconnect the brake tubes.
6. Remove the three bolts and remove the ABS actuator and electric unit (control unit).

A
B
C
D
E
BRC
G
H
I
J
K
L
M

INSTALLATION

Installation is in the reverse order of removal.

CAUTION:

To install, use a flare nut wrench (commercial service tool).

- Always tighten brake tubes to specification when installing. Refer to [BR-12, "BRAKE PIPING AND HOSE"](#) .
- Never reuse drained brake fluid.
- After installation of the ABS actuator and electric unit (control unit), refill brake system with new brake fluid. Then bleed the air from the system. Refer to [BR-11, "Bleeding Brake System"](#) .

PRECAUTIONS

PF0:00001

Precautions for Supplemental Restraint System (SRS) “AIR BAG” and “SEAT BELT PRE-TENSIONER”

EFS004QC

The Supplemental Restraint System such as “AIR BAG” and “SEAT BELT PRE-TENSIONER”, used along with a front seat belt, helps to reduce the risk or severity of injury to the driver and front passenger for certain types of collision. Information necessary to service the system safely is included in the SRS and SB section of this Service Manual.

WARNING:

- To avoid rendering the SRS inoperative, which could increase the risk of personal injury or death in the event of a collision which would result in air bag inflation, all maintenance must be performed by an authorized NISSAN/INFINITI dealer.
- Improper maintenance, including incorrect removal and installation of the SRS, can lead to personal injury caused by unintentional activation of the system. For removal of Spiral Cable and Air Bag Module, see the SRS section.
- Do not use electrical test equipment on any circuit related to the SRS unless instructed to in this Service Manual. SRS wiring harnesses can be identified by yellow and/or orange harnesses or harness connectors.

Precautions for Brake System

EFS004QD

CAUTION:

- Refer to [MA-11, "RECOMMENDED FLUIDS AND LUBRICANTS"](#) for recommended brake fluid.
- Never reuse drained brake fluid.
- Be careful not to splash brake fluid on painted areas; it may cause paint damage. If brake fluid is splashed on painted areas, wash it away with water immediately.
- To clean or wash all parts of master cylinder and disc brake caliper, use clean brake fluid.
- Never use mineral oils such as gasoline or kerosene. They will ruin rubber parts of the hydraulic system.
- Use flare nut wrench when removing and installing brake tube.
- If a brake fluid leak is found, the part must be disassembled without fail. Then it has to be replaced with a new one if a defect exists.
- Turn the ignition switch OFF and remove the connector of the ABS actuator and electric unit (control unit) or the battery terminal before performing the work.
- Always torque brake lines when installing.
- Burnish the brake contact surfaces after refinishing or replacing rotors, after replacing pads, or if a soft pedal occurs at very low mileage.

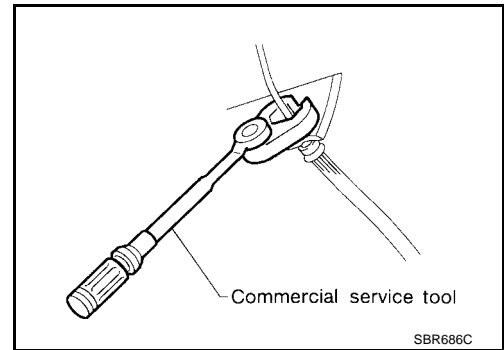

Refer to [BR-27, "BRAKE BURNISHING PROCEDURE"](#) (front disc brake) or [BR-32, "BRAKE BURNISHING PROCEDURE"](#) (rear disc brake).

WARNING:

- Clean brake pads and shoes with a waste cloth, then wipe with a dust collector.

Precautions When Using CONSULT-II

EFS004QE

When connecting CONSULT-II to data link connector, connect them through CONSULT-II CONVERTER.

CAUTION:

If CONSULT-II is used with no connection of CONSULT-II CONVERTER, malfunctions might be detected in self-diagnosis depending on control unit which carries out CAN communication.

CHECK POINTS FOR USING CONSULT-II

1. Has CONSULT-II been used without connecting CONSULT-II CONVERTER on this vehicle?
 - If YES, GO TO 2.
 - If NO, GO TO 5.

A
B
C
D
E
BRC
G
H
I
J
K
L
M

PRECAUTIONS

[ABLS/ABS]

2. Is there any indication other than indications relating to CAN communication system in the self-diagnosis results?
 - If YES, GO TO 3.
 - If NO, GO TO 4.
3. Based on self-diagnosis results unrelated to CAN communication, carry out the inspection.
4. Malfunctions may be detected in self-diagnosis depending on control units carrying out CAN communication. Therefore, erase the self-diagnosis results.
5. Diagnose CAN communication system. Refer to [LAN-7, "CAN COMMUNICATION"](#).

Precautions for Brake Control

EFS004QF

- During ABS operation, the brake pedal may vibrate lightly and a mechanical noise may be heard. This is normal.
- Just after starting vehicle, the brake pedal may vibrate or a motor operating noise may be heard from engine compartment. This is a normal status of operation check.
- Stopping distance may be longer than that of vehicles without ABS when vehicle drives on rough, gravel, or snow-covered (fresh, deep snow) roads.
- When an error is indicated by ABS or another warning lamp, collect all necessary information from customer (what symptoms are present under what conditions) and check for simple causes before starting diagnosis. Besides electrical system inspection, check brake booster operation, brake fluid level, and fluid leaks.
- If incorrect tire sizes or types are installed on the vehicle or brake pads are not Genuine NISSAN parts, stopping distance or steering stability may deteriorate.
- If there is a radio, antenna or related wiring near control module, ABS function may have a malfunction or error.
- If aftermarket parts (car stereo, CD player, etc.) have been installed, check for incidents such as harness pinches, open circuits or improper wiring.

Precautions for CAN System

EFS004QG

- Do not apply voltage of 7.0V or higher to terminal to be measured.
- Maximum open terminal voltage of tester in use must be less than 7.0V.
- Before checking harnesses, turn ignition switch OFF and disconnect battery negative cable.
- Area to be repaired must be soldered and wrapped with tape. Make sure that fraying of twisted wire is within 110 mm (4.33 in).

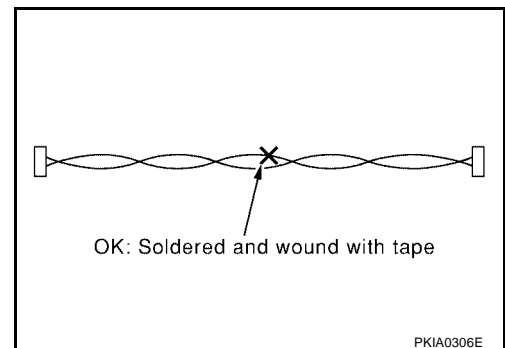

- Do not make a bypass connection to repaired area. (If the circuit is bypassed, characteristics of twisted wire will be lost.)

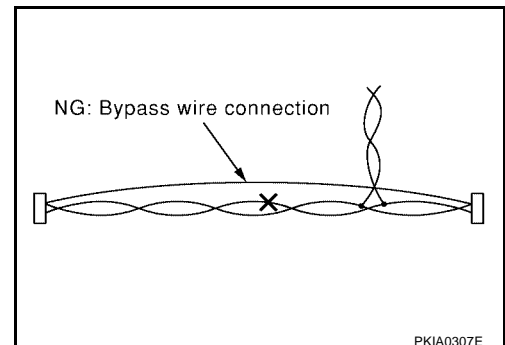

Wiring Diagrams and Trouble Diagnosis

EF5004QH

When you read wiring diagrams, refer to the following:

- [GI-14, "How to Read Wiring Diagrams"](#).
- [PG-4, "POWER SUPPLY ROUTING CIRCUIT"](#).

When you perform trouble diagnosis, refer to the following:

- [GI-11, "HOW TO FOLLOW TEST GROUPS IN TROUBLE DIAGNOSES"](#).
- [GI-27, "How to Perform Efficient Diagnosis for an Electrical Incident"](#).

A

B

C

D

E

BRC

G

H

I

J

K

L

M

PREPARATION

[ABLS/ABS]

PREPARATION

PF0:0002

Special Service Tool

EF004QI

The actual shapes of Kent-Moore tools may differ from those of special service tools illustrated here.

Tool number (Kent-Moore No.) Tool name	Description
(J-45741) ABS active wheel sensor tester	Checking operation of ABS active wheel sensors
205-D002 (—) Bearing splitter	Removing axle shaft bearing

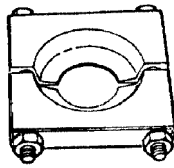
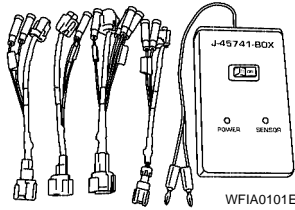

Commercial Service Tools

EF004QJ

Tool name	Description
1. Flare nut crowfoot 2. Torque wrench	Removing and installing brake piping a: 10mm (0.39 in)/12mm (0.47 in)

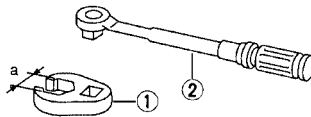

SYSTEM DESCRIPTION

System Components

A
B
C
D
E
BRC
G
H
I
J
K
L
M

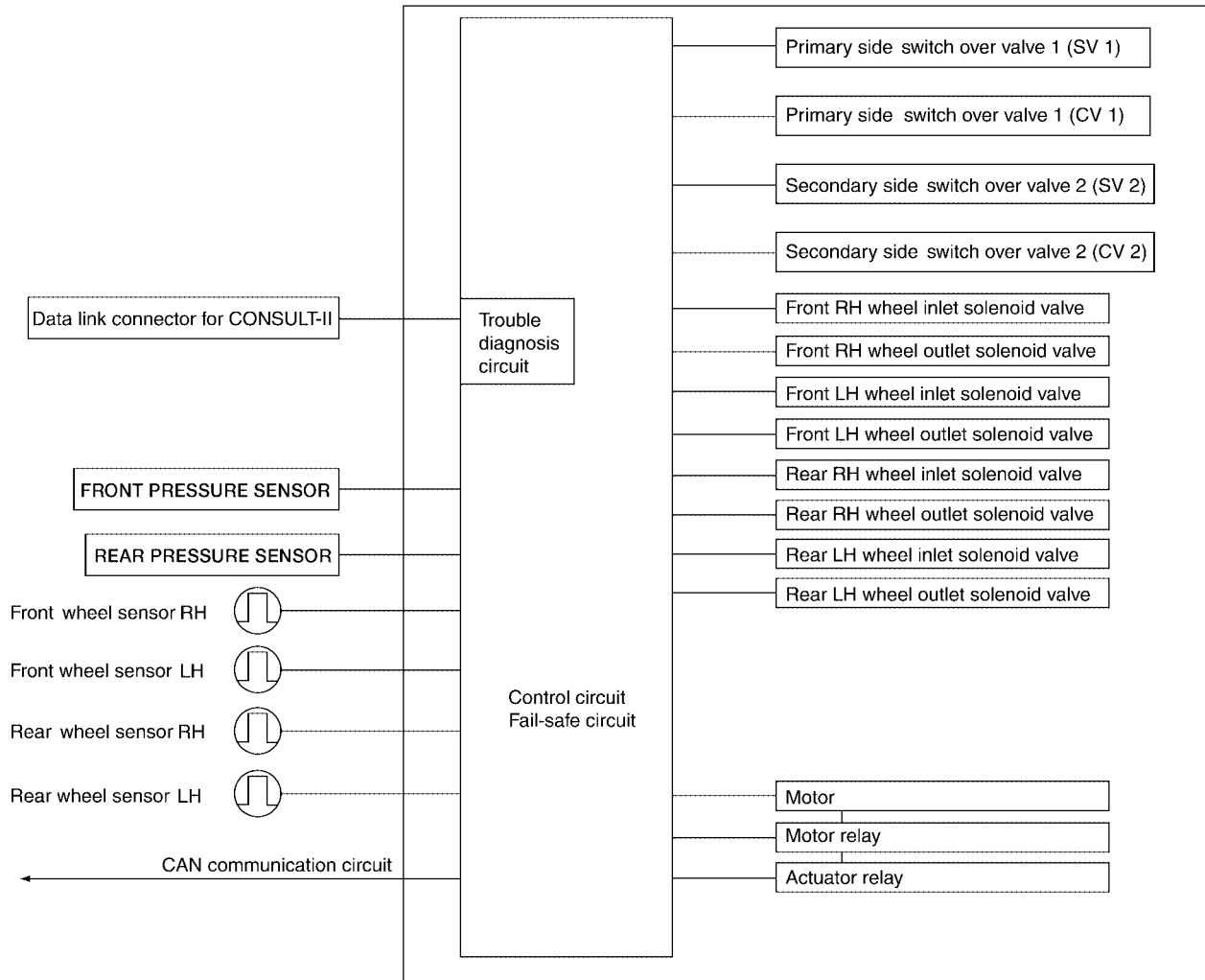

ABS actuator and electric unit (control unit)

ABS Function

EFS004QL

- The Anti-Lock Brake System detects wheel revolution while braking and improves handling stability during sudden braking by electrically preventing wheel lockup. Maneuverability is also improved for avoiding obstacles.
- If the electrical system malfunctions, the Fail-Safe function is activated, the ABS becomes inoperative and the ABS warning lamp turns on.
- The electrical system can be diagnosed using CONSULT-II.
- During ABS operation, the brake pedal may vibrate lightly and a mechanical noise may be heard. This is normal.
- Just after starting the vehicle, the brake pedal may vibrate or a motor operating noise may be heard from engine compartment. This is a normal status of operation check.
- Stopping distance may be longer than that of vehicles without ABS when vehicle drives on rough, gravel, or snow-covered (fresh, deep snow) roads.

EBD Function

EFS004QM

- Electronic Brake Distribution is a function that detects subtle slippages between the front and rear wheels during braking, and it improves handling stability by electronically controlling the brake fluid pressure which results in reduced rear wheel slippage.
- If the electrical system malfunctions, the Fail-Safe function is activated, the EBD and ABS become inoperative, and the ABS warning lamp and brake warning lamp are turned on.
- The electrical system can be diagnosed using CONSULT-II.
- During EBD operation, the brake pedal may vibrate lightly and a mechanical noise may be heard. This is normal.
- Just after starting the vehicle, the brake pedal may vibrate or a motor operating noise may be heard from engine compartment. This is a normal status of operation check.

ABLS Function

EFS004QN

- Active brake limited slip is a function to improve vehicle traction. Spinning of the drive wheels is detected by the ABS actuator and electric unit (control unit) using inputs from the wheel speed sensors. If wheel spin occurs, the ABLS system brakes the spinning wheel which distributes the driving power to the other drive wheel.
- The SLIP indicator lamp turns on to inform the driver of ABLS operation.
- During ABLS operation, the brake pedal may vibrate lightly and a mechanical noise may be heard. This is normal.

Fail-Safe Function

EFS004QO

CAUTION:

If the Fail-Safe function is activated, perform the Self Diagnosis for ABS/ABLS system.

ABS/EBD SYSTEM

In case of an electrical malfunction with the ABS, the ABS warning lamp will turn on. In case of an electrical malfunction with the EBD system, the brake warning lamp and ABS warning lamp will turn on. The system will revert to one of the following conditions of the Fail-Safe function.

1. For ABS malfunction, only the EBD is operative and the condition of the vehicle is the same condition of vehicles without ABS/ABLS system.
2. For EBD malfunction, the EBD and ABS become inoperative, and the condition of the vehicle is the same as the condition of vehicles without ABS/ABLS or EBD system.

ABLS SYSTEM

In case of an ABLS system malfunction, the ABS warning lamp will turn on and only the EBD is operative. The condition of the vehicle is the same as the condition of vehicles without ABS/ABLS system.

Hydraulic Circuit Diagram

EFS004QP

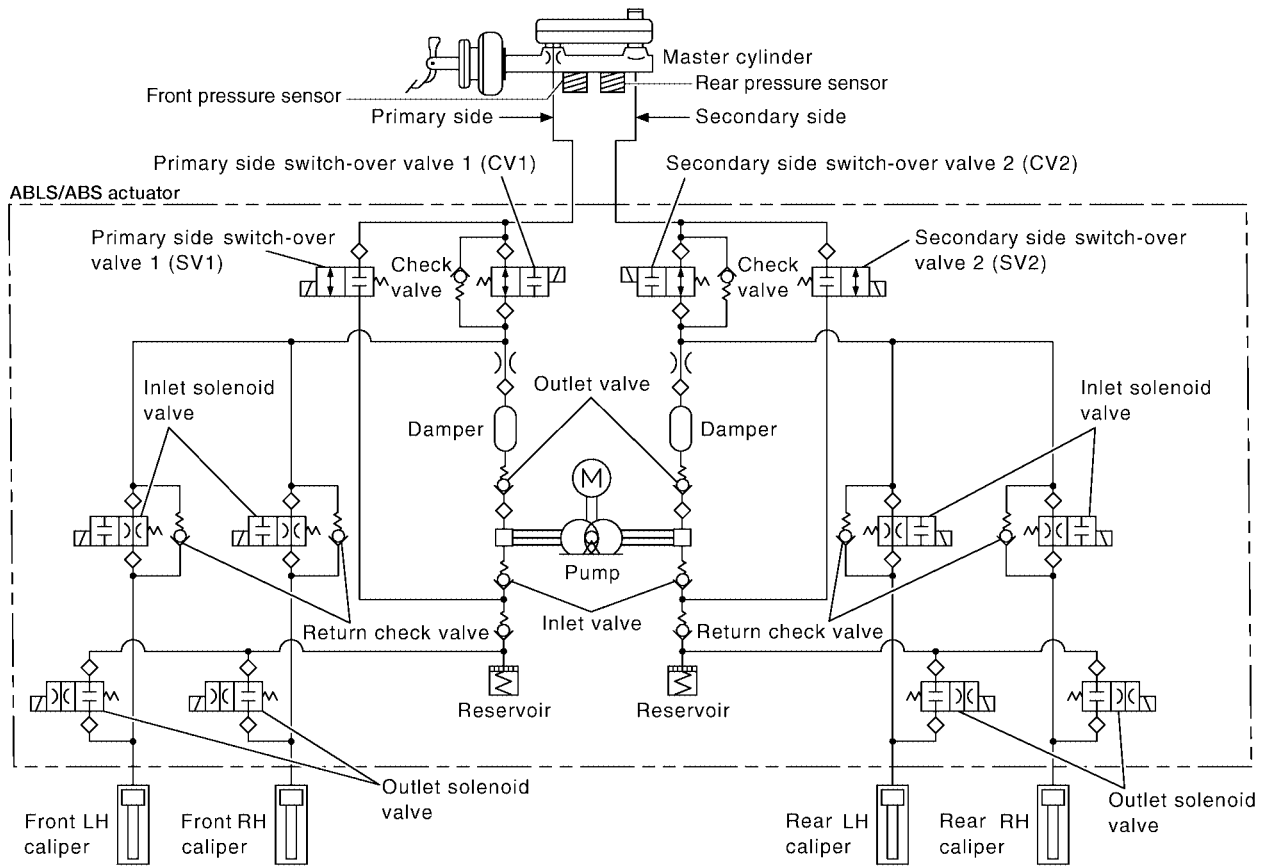

A
B
C
D
E
BRC
G
H
I
J
K
L
M

WFIA0302E

CAN COMMUNICATION

PF:23710

System Description

EF004QQ

Refer to [LAN-7, "CAN COMMUNICATION"](#) .

TROUBLE DIAGNOSIS

How to Perform Trouble Diagnoses for Quick and Accurate Repair INTRODUCTION

The ABS/ABLS system has an electronic control unit to control major functions. The control unit accepts input signals from sensors and controls actuator operation. It is also important to check for conventional problems such as air leaks in the booster or lines, lack of brake fluid, or other problems with the brake system.

It is much more difficult to diagnose a problem that occurs intermittently rather than continuously. Most intermittent problems are caused by poor electrical connections or faulty wiring. In this case, careful checking of suspicious circuits may help prevent the replacement of good parts.

A visual check only may not find the cause of the problem, so a road test should be performed.

Before undertaking actual checks, take just a few minutes to talk with a customer who approaches with an ABS/ABLS complaint. The customer is a very good source of information on such problems, especially intermittent ones. Through the talks with the customer, find out what symptoms are present and under what conditions they occur. Start your diagnosis by looking for "conventional" problems first. This is one of the best ways to troubleshoot brake problems on an ABS/ABLS equipped vehicle. Also check related Service Bulletins for information.

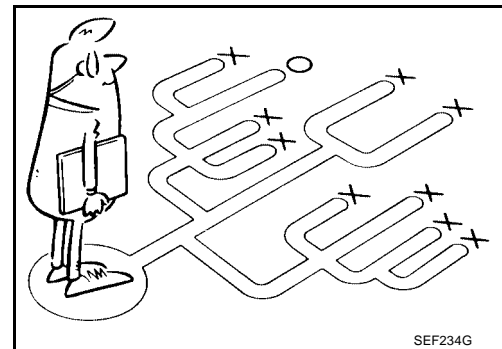
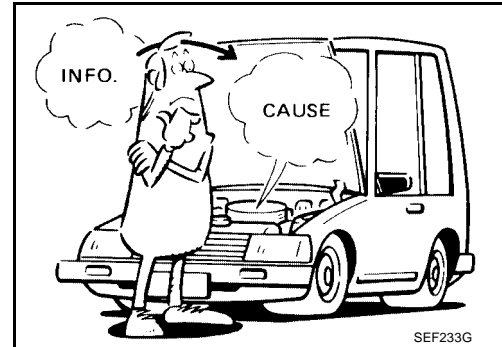

A

B

C

D

E

BRC

G

H

I

J

K

L

M

TROUBLE DIAGNOSIS

[ABLS/ABS]

WORK FLOW

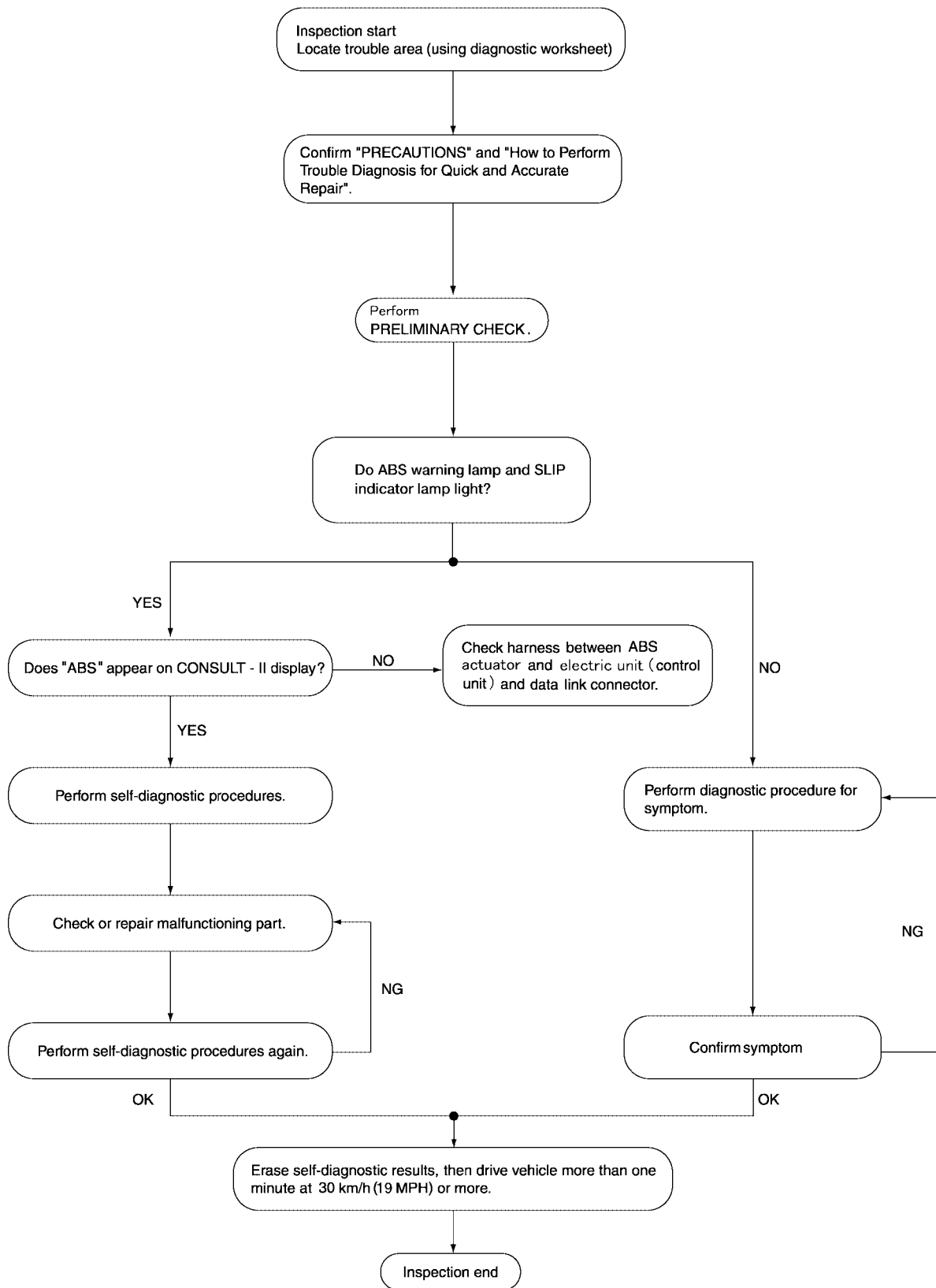

WFIA0364E

TROUBLE DIAGNOSIS

[ABLS/ABS]

CLARIFY CONCERN

- A customer's description of a vehicle concern may vary depending on the individual. It is important to clarify the customer's concern.
- Ask the customer about what symptoms are present under what conditions. Use this information to reproduce the symptom while driving.
- It is also important to use the diagnosis sheet to understand what type of trouble the customer is having.

KEY POINTS

WHAT Vehicle model
WHEN Date, Frequencies
WHERE Road conditions
HOW Operating conditions,
 Weather conditions,
 Symptoms

SBR339B

EXAMPLE OF DIAGNOSIS SHEET

Customer name	Model & Year	VIN	
Engine #	Trans.	Mileage	
Incident Date	Manuf. Date	In Service Date	
Symptoms	<input type="checkbox"/> Noise and vibration (from engine compartment)	<input type="checkbox"/> ABS warning lamp activates	<input type="checkbox"/> Pedal operation
	<input type="checkbox"/> Noise and vibration (from axle)	<input type="checkbox"/> SLIP indicator lamp activates	<input type="checkbox"/> Large stroke pedal operation
	<input type="checkbox"/> ABLS does not work (drive wheels slip when accelerating)	<input type="checkbox"/> ABS does not work (wheels slip when braking)	<input type="checkbox"/> Firm pedal
	<input type="checkbox"/> Lack of sense of acceleration		
Engine conditions	<input type="checkbox"/> When starting <input type="checkbox"/> After starting		
Road conditions	<input type="checkbox"/> Low friction road (<input type="checkbox"/> Snow <input type="checkbox"/> Gravel <input type="checkbox"/> Other) <input type="checkbox"/> Bumps/potholes		
Driving conditions	<input type="checkbox"/> Full-acceleration <input type="checkbox"/> High speed cornering <input type="checkbox"/> Vehicle speed: Greater than 10 km/h (6 MPH) <input type="checkbox"/> Vehicle speed: 10 km/h (6 MPH) or less <input type="checkbox"/> Vehicle is stopped		
Applying brake conditions	<input type="checkbox"/> Suddenly <input type="checkbox"/> Gradually		
Other conditions	<input type="checkbox"/> Operation of electrical equipment <input type="checkbox"/> Shift change <input type="checkbox"/> Other descriptions		

WFIA0365E

A
B
C
D
E
G
H
I
J
K
L
M

BRC

Component Parts and Harness Connector Location

EFS004QS

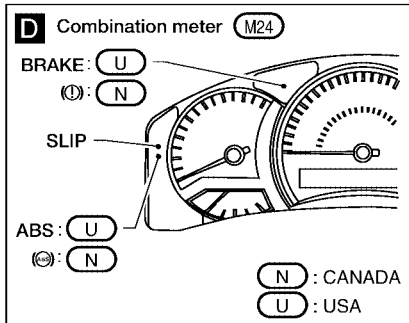
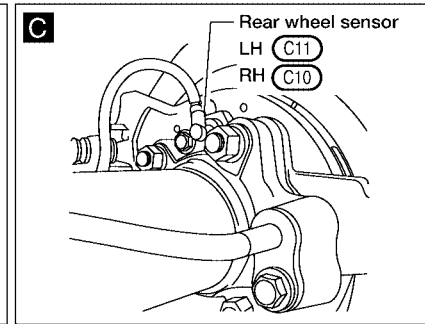
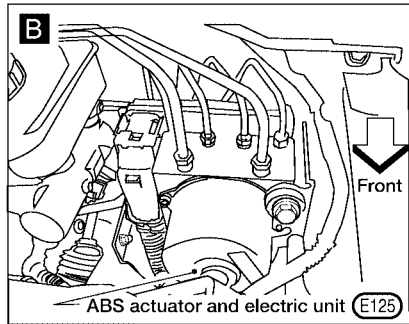
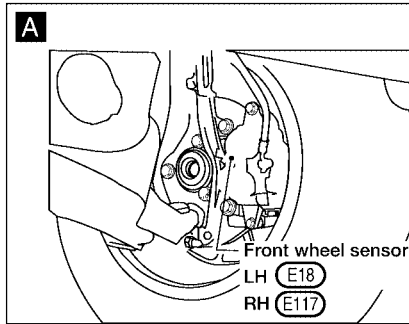
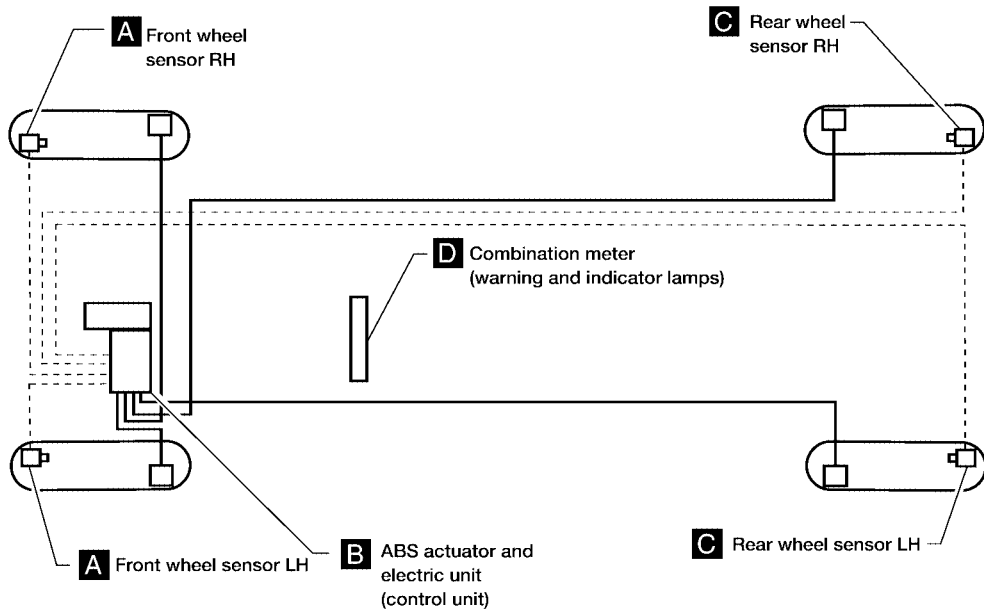

WFIA0372E

Schematic

EFS004QT

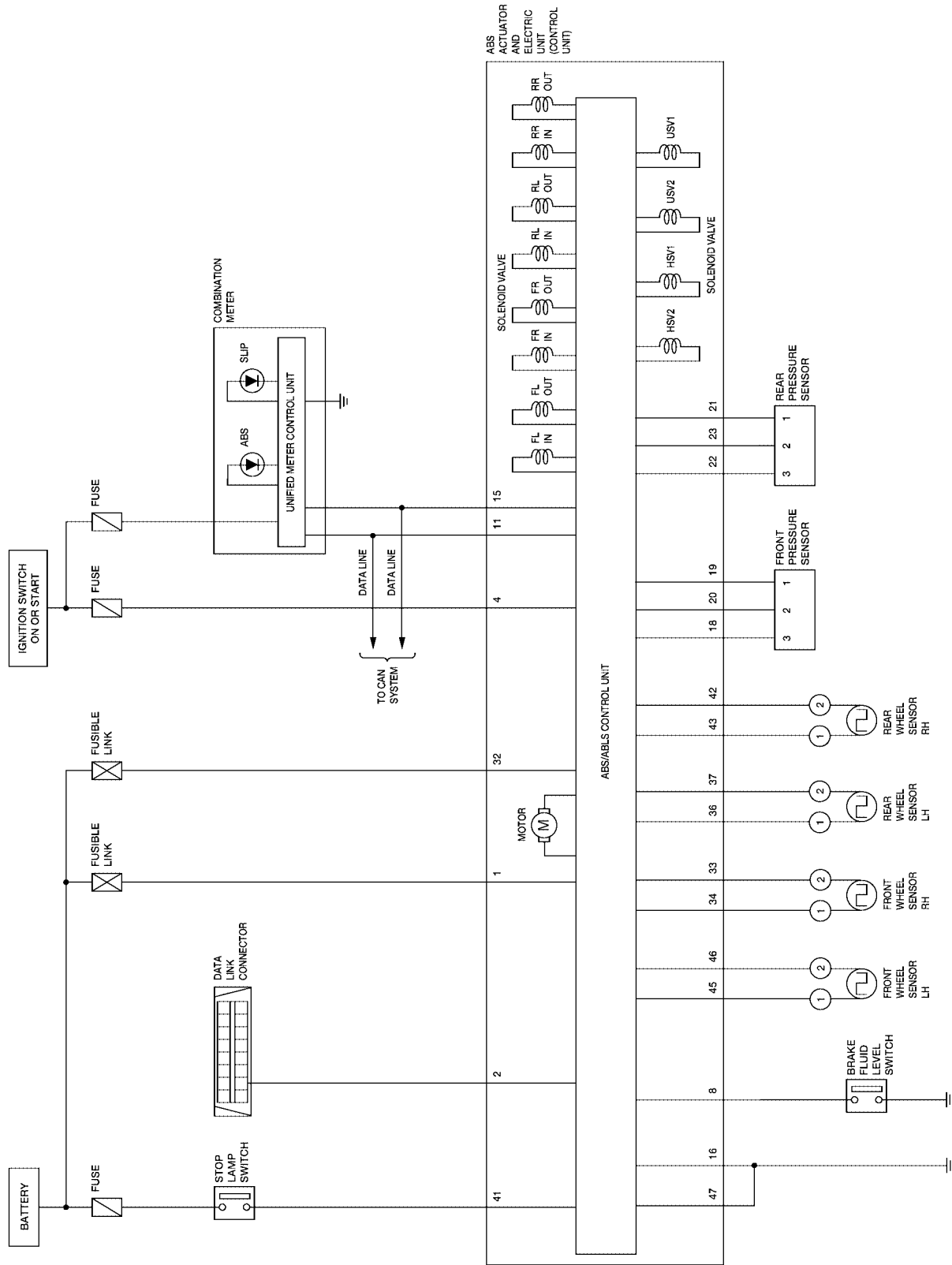

A
B
C
D
E
BRC
G
H
I
J
K
L
M

TROUBLE DIAGNOSIS

[ABLS/ABS]

Wiring Diagram — ABL5 —

EFS004QU

BRC-ABLS-01

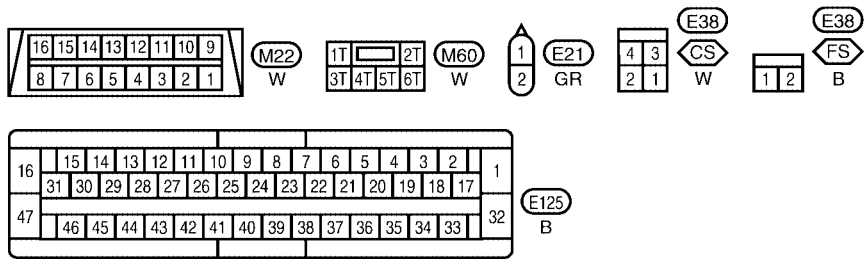
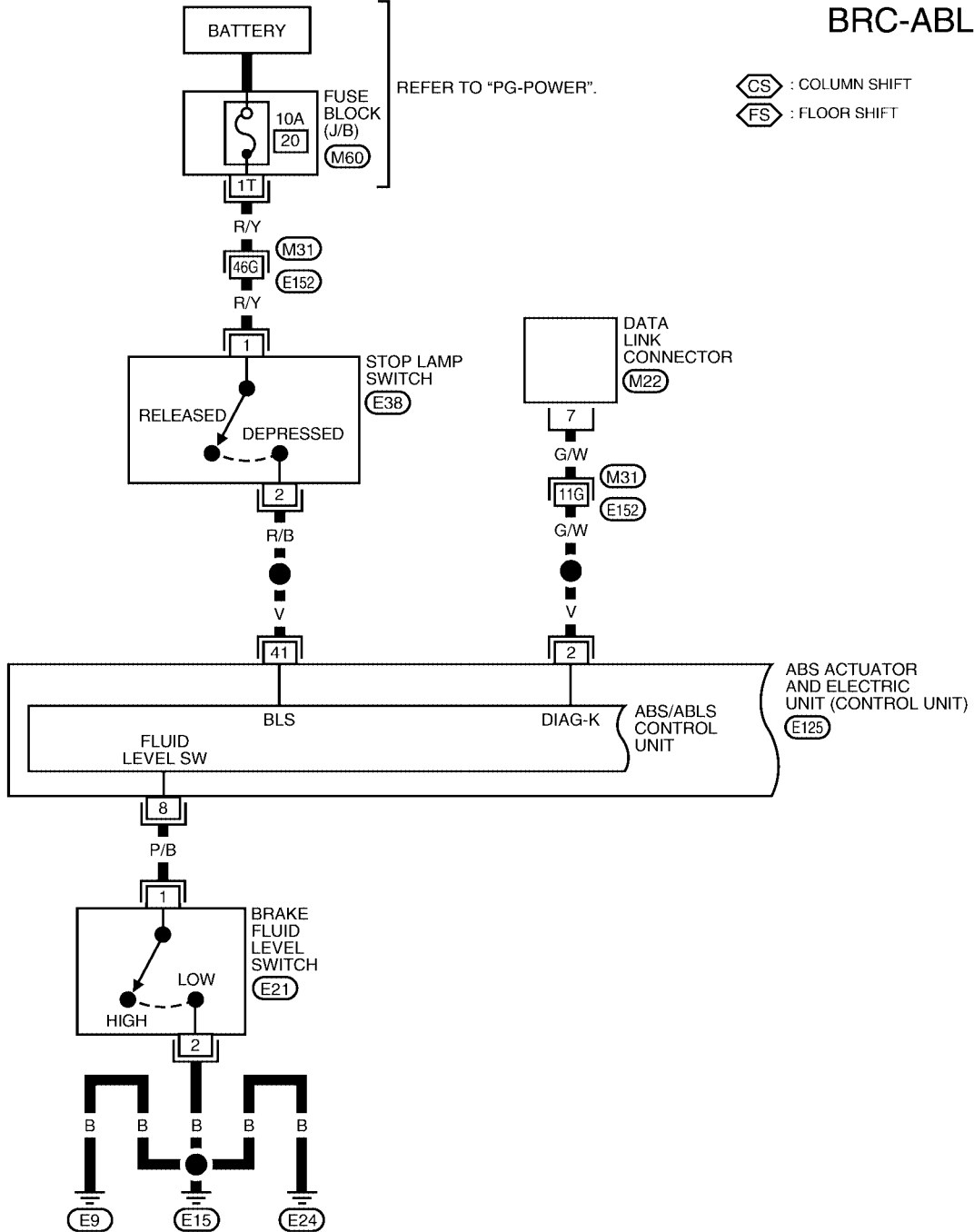

REFER TO THE FOLLOWING.
 (M31) - SUPER MULTIPLE JUNCTION (SMJ)

WFWA0204E

TROUBLE DIAGNOSIS

[ABLS/ABS]

BRC-ABLS-02

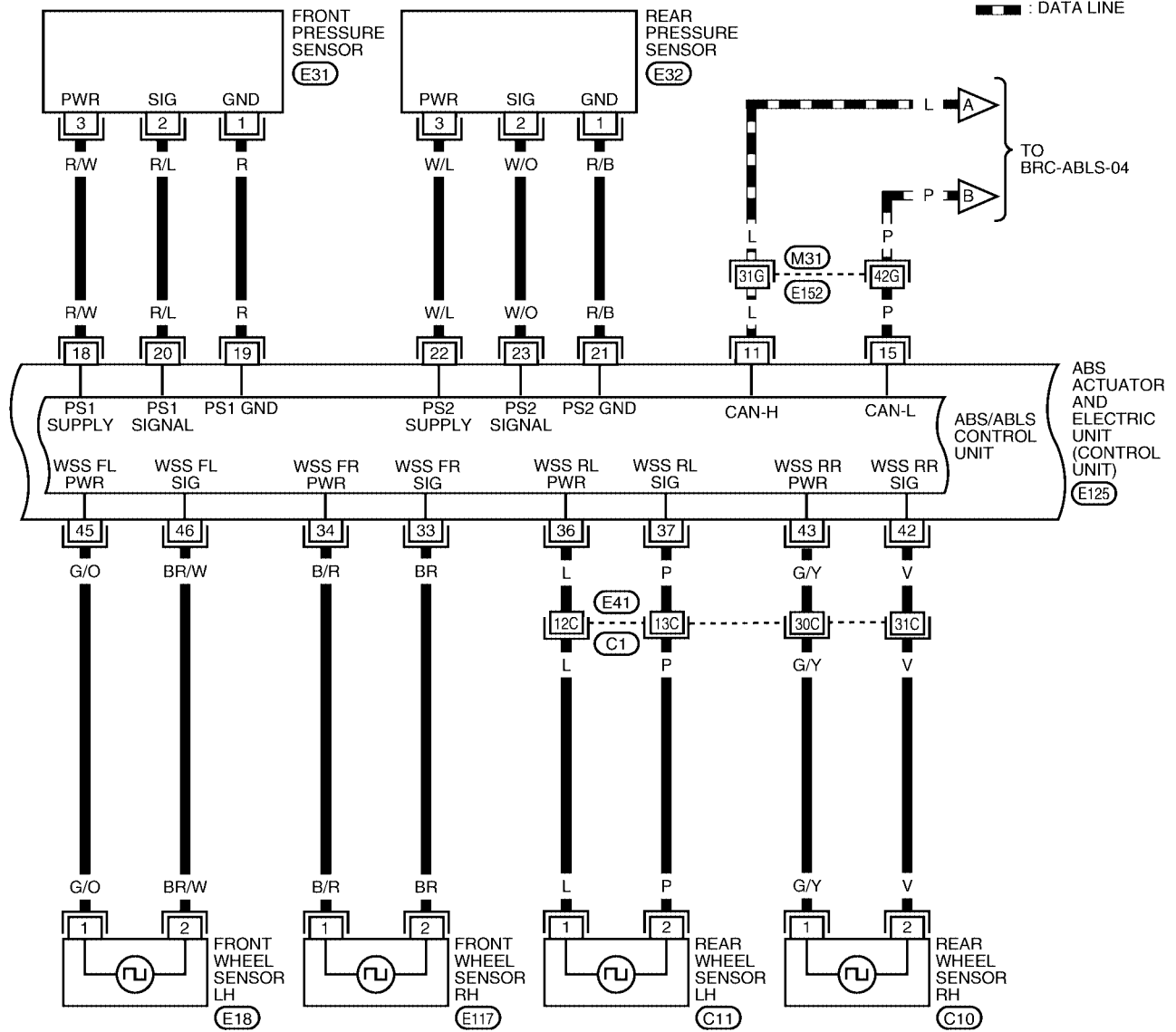

A
B
C
D
E
BRC
G
H
I
J
K
L
M

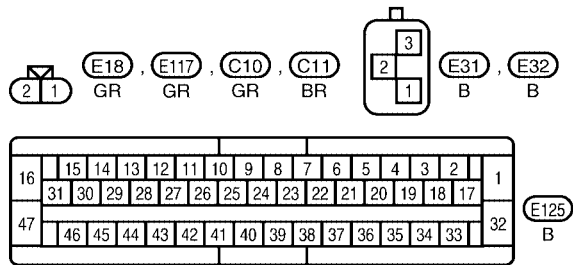

REFER TO THE FOLLOWING.
 (C1), (M31) - SUPER
 MULTIPLE JUNCTION (SMJ)

WFWA0205E

TROUBLE DIAGNOSIS

[ABLS/ABS]

BRC-ABLS-03

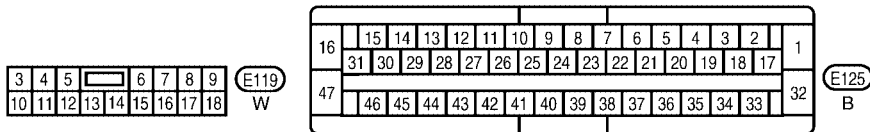
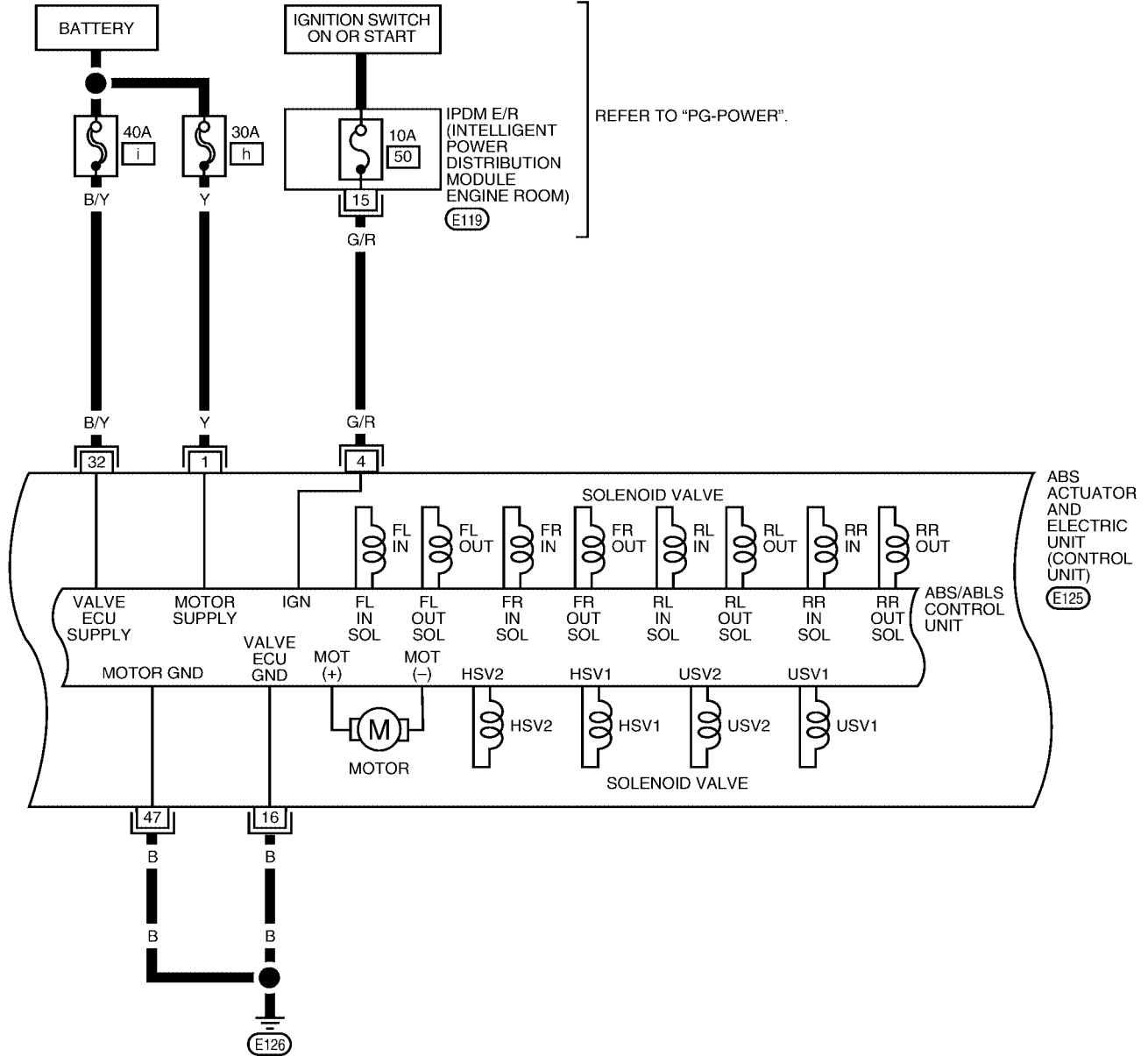

WFWA0206E

TROUBLE DIAGNOSIS

[ABLS/ABS]

BRC-ABLS-04

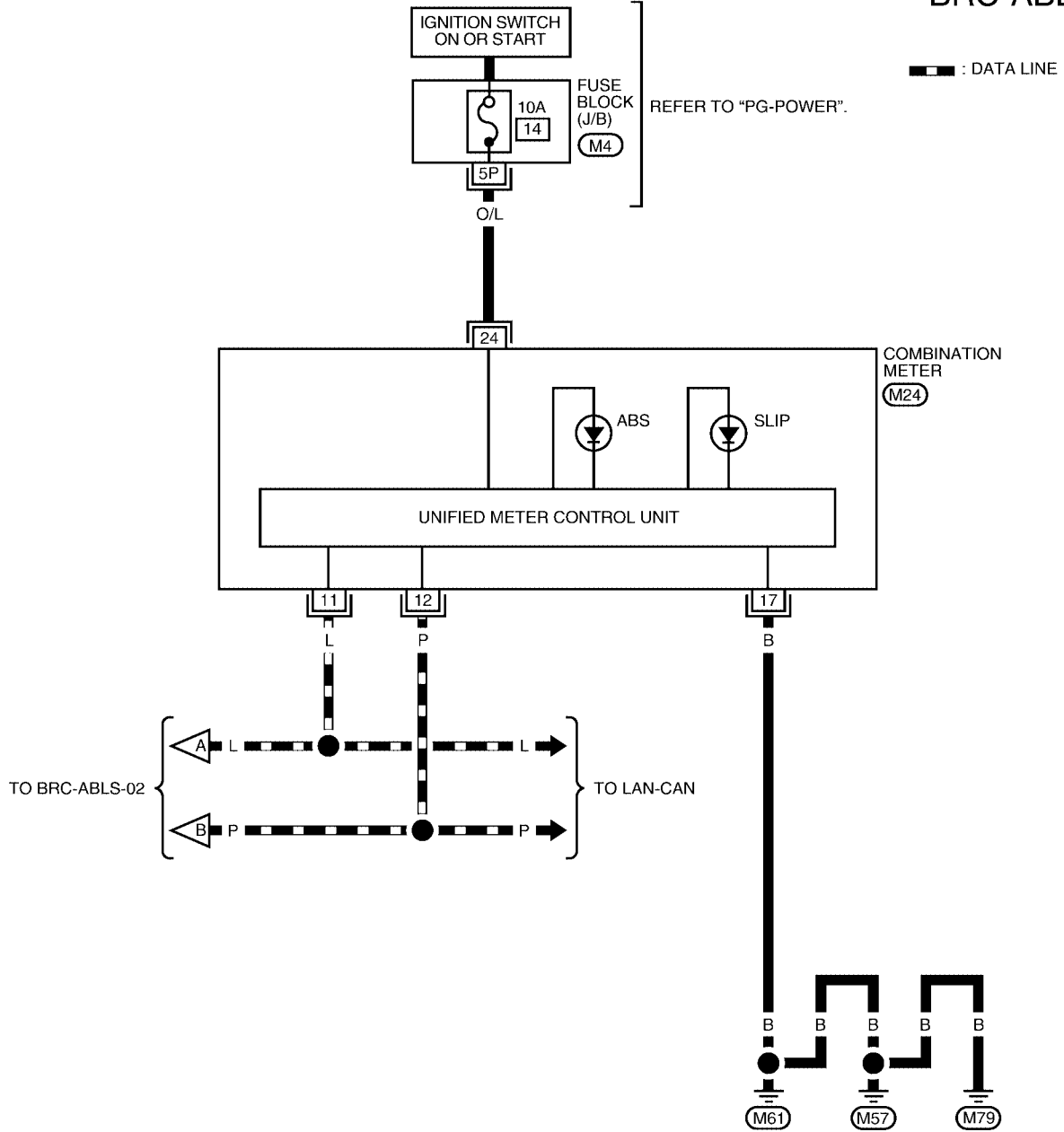

A
B
C
D
E
BRC
G
H
I
J
K
L
M

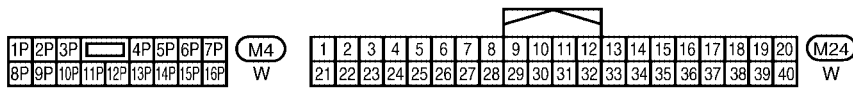

WFWA0207E

Basic Inspection**BRAKE FLUID LEVEL, FLUID LEAK, AND BRAKE PAD INSPECTION**

1. Check fluid level in the brake fluid reservoir. If fluid level is low, add fluid.
2. Check the brake piping and around the ABS actuator and electric unit (control unit) for leaks. If there is leaking or seeping fluid, check the following items.
 - If ABS actuator and electric unit (control unit) connection is loose, tighten the piping to the specified torque and recheck for leaks.
 - If there is damage to the connection flare nut or ABS actuator and electric unit (control unit) threads, replace the damaged part and recheck for leaks.
 - When there is fluid leaking or seeping from a fluid connection, use a clean cloth to wipe off the fluid and recheck for leaks. If fluid is still seeping out, replace the damaged part. If the fluid is leaking at the ABS actuator and electric unit (control unit), replace the ABS actuator and electric unit (control unit) assembly.

CAUTION:

The ABS actuator and electric unit (control unit) cannot be disassembled and must be replaced as an assembly.

3. Check the brake pads for excessive wear.

POWER SYSTEM TERMINAL LOOSENESS AND BATTERY INSPECTION

Make sure the battery positive cable, negative cable and ground connection are not loose. In addition, make sure the battery is sufficiently charged.

ABS WARNING LAMP AND SLIP INDICATOR LAMP INSPECTION

1. Make sure ABS warning lamp and SLIP indicator lamp turn on for approximately 1 second when the ignition switch is turned ON. If they do not, check CAN communications. If there are no errors with CAN communication system, check combination meter. Refer to [DI-5, "COMBINATION METERS"](#).
2. Make sure the lamps turn off approximately 1 second after the ignition switch is turned ON. If the lamps do not turn off, conduct self-diagnosis.
3. Make sure ABS warning lamp turns off approximately 2 seconds after the engine is started. If ABS warning lamp has not turned off 10 seconds after the engine has been started, conduct self-diagnosis of the ABS actuator and electric unit (control unit).
4. After conducting the self-diagnosis, be sure to erase the error memory. Refer to [BRC-64, "CONSULT-II Function \(ABS\)"](#).

TROUBLE DIAGNOSIS

[ABLS/ABS]

Warning Lamp and Indicator Timing

EFS004QW

Condition	ABS warning lamp	SLIP indicator lamp	Remarks
When the ignition switch is OFF	—	—	—
After the ignition switch is turned ON for approx. 1 second	X	X	—
After the ignition switch is turned ON for approx. 2 seconds	—	—	Lamp goes off approx. 2 seconds after the engine is started.
ABS/ABLS malfunction	X	—	When the ABS actuator and electric unit (control unit) is malfunctioning (power supply or ground malfunction).
	X	—	

X: ON
—: OFF

Control Unit Input/Output Signal Standard REFERENCE VALUE FROM CONSULT-II

EFS004QX

CAUTION:

The display shows the control unit calculation data, so a normal value might be displayed even in the event the output circuit (harness) is open or short circuited.

Monitor item	Display content	Data monitor		Note: Error inspection checklist
		Condition	Reference value in normal operation	
N POSI SIG	PNP switch signal ON/OFF condition	A/T shift position = N position	ON	BRC-81, "CAN Communication System Inspection"
		A/T shift position = other than N positions	OFF	
P POSI SIG	PNP switch signal ON/OFF condition	A/T shift position P position	ON	BRC-81, "CAN Communication System Inspection"
		A/T shift position = other than P positions	OFF	
GEAR	A/T gear position	1st gear	1	—
		2nd gear	2	
		3rd gear	3	
		4th gear	4	
		5th gear	5	
FR RH SENSOR FR LH SENSOR RR RH SENSOR RR LH SENSOR	Wheel speed	Vehicle stopped	0 [km/h (MPH)]	BRC-72, "Wheel Sensor System Inspection"
		Vehicle running (Note 1)	Almost in accordance with speedometer display (within ±10%)	
ACCEL POS SIG	Open/close condition of throttle valve (linked with accelerator pedal).	Accelerator pedal not depressed (ignition switch is ON)	0%	BRC-81, "CAN Communication System Inspection"
		Depress accelerator pedal (ignition switch is ON)	0 to 100%	
ENGINE SPEED	With engine running	With engine stopped	0 rpm	BRC-73, "Engine System Inspection"
		Engine running	Almost in accordance with tachometer display	
BATTERY VOLT	Battery voltage supplied to ABS actuator and electric unit (control unit)	Ignition switch ON	10 to 16V	BRC-77, "ABS/ABLS Control Unit Power and Ground Systems Inspection"

TROUBLE DIAGNOSIS

[ABLS/ABS]

Monitor item	Display content	Data monitor		Note: Error inspection checklist
		Condition	Reference value in normal operation	
STOP LAMP SW	Stop lamp switch operation	Brake pedal depressed	ON	BRC-76, "Stop Lamp Switch System Inspection"
		Brake pedal not depressed	OFF	
ABS WARN LAMP	ABS warning lamp ON condition (Note 2)	ABS warning lamp ON	ON	—
		ABS warning lamp OFF	OFF	
MOTOR RELAY	Operation status of motor and motor relay	Ignition switch ON or running (ABS not activated)	OFF	BRC-75, "Actuator Motor, Motor Relay, and Circuit Inspection"
		Ignition switch ON or engine running (ABS activated)	ON	
ACTUATOR RLY	Actuator relay operation status	Vehicle stopped (Ignition switch ON)	OFF	BRC-75, "Actuator Motor, Motor Relay, and Circuit Inspection"
		Vehicle stopped (Engine running)	ON	
SLIP LAMP	SLIP indicator lamp status (Note 3)	When SLIP indicator lamp is ON	ON	BRC-81, "CAN Communication System Inspection"
		When SLIP indicator lamp is OFF	OFF	
FR LH IN SOL FR LH OUT SOL FR RH IN SOL FR RH OUT SOL RR RH IN SOL RR RH OUT SOL RR LH IN SOL RR LH OUT SOL	Solenoid valve operation	Actuator (solenoid) is active ("ACTIVE TEST" with CONSULT-II) or actuator relay is inactive (in fail-safe mode).	ON	BRC-74, "Solenoid and Change-Over Valve System Inspection"
		When actuator (solenoid) is not active and actuator relay is active (ignition switch ON).	OFF	
CV1 CV2 SV1 SV2	Switch-over valve status	When actuator (switch-over valve) is active ("ACTIVE TEST" with CONSULT-II) or actuator relay is inactive (when in fail-safe mode).	ON	BRC-74, "Solenoid and Change-Over Valve System Inspection"
		When actuator (switch-over valve) is not active and actuator relay is active (ignition switch ON).	OFF	
PRESS SENSOR	Brake fluid pressure detected by pressure sensor	Do not step on the Brake pedal (When ignition switch is ON)	Approx. 0 bar	—
		Step on the Brake pedal (When ignition switch is ON)	-40 to 300 bar	
FLUID LEV SW	ON/OFF status of brake fluid level switch	When brake fluid level switch ON	ON	DI-30, "WARNING LAMPS"
		When brake fluid level switch OFF	OFF	
ABS SIGNAL EBD SIGNAL	Signal status	ABS active EBD active	ON	ABS system EBD system
		ABS not active EBD not active	OFF	
ABS FAIL SIG EBD FAIL SIG	Fail signal status	ABS fail EBD fail	ON	ABS system EBD system
		ABS normal EBD normal	OFF	

Note 1: Confirm tire pressure is normal.

Note 2: ON/OFF timing of ABS warning lamp

ON: For approximately 1 second after ignition switch is turned ON, or when a malfunction is detected.

TROUBLE DIAGNOSIS

[ABLS/ABS]

OFF: Approximately 1 second after ignition switch is turned ON (when system is in normal operation) and ABLs/ABS function is not activated.

Note 3: SLIP indicator lamp ON/OFF timing

ON: For approximately 1 second after ignition switch is turned ON, or when ABLs function is activated while driving.

OFF: Approximately 1 second after ignition switch is turned ON (when system is in normal operation) and ABLs function is not activated.

A

B

C

D

E

BRC

G

H

I

J

K

L

M

CONSULT-II Function (ABS)

CONSULT-II can display each diagnostic item using the diagnostic test modes shown following.

ABS diagnostic mode	Description
WORK SUPPORT	Supports inspection and adjustments. Commands are transmitted to the ABS actuator and electric unit (control unit) for setting the status suitable for required operation, input/output signals are received from the ABS actuator and electric unit (control unit) and received data is displayed.
SELF-DIAG RESULTS	Displays ABS actuator and electric unit (control unit) self-diagnosis results.
DATA MONITOR	Displays ABS actuator and electric unit (control unit) input/output data in real time.
CAN DIAG SUPPORT MNTR	The result of transmit/receive diagnosis of CAN communication can be read.
ACTIVE TEST	Operation of electrical loads can be checked by sending drive signal to them.
FUNCTION TEST	Conducted by CONSULT-II instead of a technician to determine whether each system is "OK" or "NG".
ECU PART NUMBER	ABS actuator and electric unit (control unit) part number can be read.

CONSULT-II BASIC OPERATION PROCEDURE

1. Turn ignition switch OFF.
2. Connect CONSULT-II and CONSULT-II CONVERTER to the data link connector.

CAUTION:

If CONSULT-II is used with no connection of CONSULT-II CONVERTER, malfunctions might be detected in self-diagnosis depending on control unit which carries out CAN communication.

3. Turn ignition switch ON.

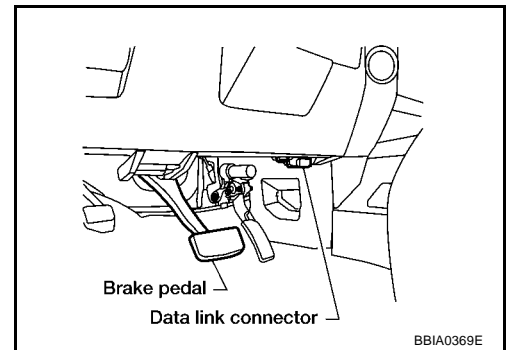

4. Touch "START (NISSAN BASED VHCL)".

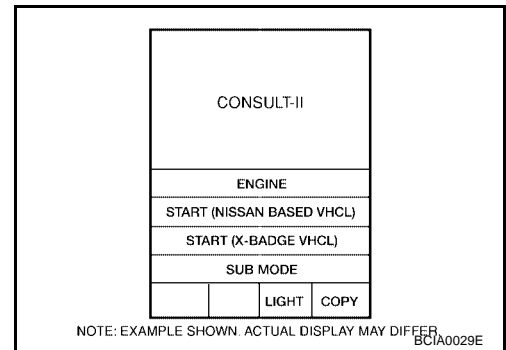

5. Touch "ABS" in the "SELECT SYSTEM" screen.
If "ABS" is not indicated, go to [GI-38, "CONSULT-II Data Link Connector \(DLC\) Circuit"](#).

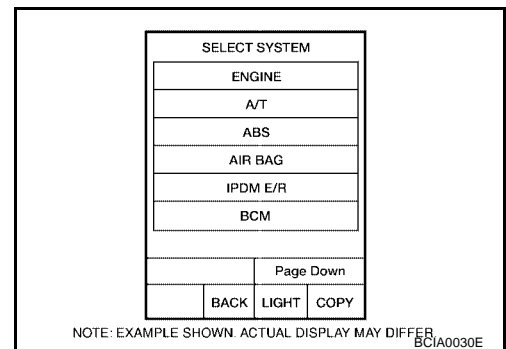

6. Select the required diagnostic location from the "SELECT DIAG MODE" screen.
For further information, see the CONSULT-II Operation Manual.

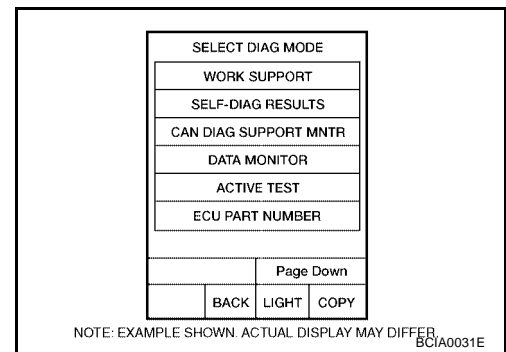

SELF-DIAGNOSIS

Description

If an error is detected in the system, the ABS warning lamp will turn on. In this case, perform self-diagnosis as follows:

Operation Procedure

1. Turn ignition switch OFF.
2. Connect CONSULT-II and CONSULT-II CONVERTER to the data link connector.

CAUTION:

If CONSULT-II is used with no connection of CONSULT-II CONVERTER, malfunctions might be detected in self-diagnosis depending on control unit which carries out CAN communication.

3. Turn ignition switch ON.
4. Start engine and drive at approximately 30 km/h (19 MPH) or more for approximately 1 minute.
5. After stopping the vehicle, with the engine running, touch "START (NISSAN BASED VHCL)", "ABS", "SELF-DIAG RESULTS" in order on the CONSULT-II screen.

CAUTION:

If "START (NISSAN BASED VHCL)" is touched immediately after starting the engine or turning on the ignition switch, "ABS" might not be displayed in the SELECT SYSTEM screen. In this case, repeat the operation from step 1.

6. The self-diagnostic results are displayed. (If necessary, the self-diagnostic results can be printed out by touching "PRINT".)
 - When "NO DTC IS DETECTED" is displayed, check the ABS warning lamp.
7. Conduct the appropriate inspection from the display item list, and repair or replace the malfunctioning component.
8. Start engine and drive at approximately 30 km/h (19 MPH) or more for approximately 1 minute.

CAUTION:

● When a wheel sensor "short-circuit" is detected, if the vehicle is not driven at 30 km/h (19 MPH) for at least 1 minute, the ABS warning lamp will not turn off even if the malfunction is repaired.

9. Turn ignition switch OFF to prepare for erasing the memory.
10. Start the engine and touch "START (NISSAN BASED VHCL)", "ABS", "SELF-DIAG RESULTS", "ERASE" in order on the CONSULT-II screen to erase the error memory.

If "ABS" is not indicated, go to [GI-38, "CONSULT-II Data Link Connector \(DLC\) Circuit"](#).

CAUTION:

If the error memory is not erased, re-conduct the operation from step 5.

11. For the final inspection, drive at approximately 30 km/h (19 MPH) or more for approximately 1 minute and confirm that the ABS warning lamp is off.

TROUBLE DIAGNOSIS

[ABLS/ABS]

Display Item List

Self-diagnostic item	Malfunction detecting condition	Check system
FR LH SENSOR 1 [C1104]	Circuit of front LH wheel sensor is open, shorted or sensor power voltage is unusual.	BRC-72, "Wheel Sensor System Inspection" (Note 1)
RR RH SENSOR 1 [C1101]	Circuit of rear RH wheel sensor is open, shorted or sensor power voltage is unusual.	
FR RH SENSOR 1 [C1103]	Circuit of front RH wheel sensor is open, shorted or sensor power voltage is unusual.	
RR LH SENSOR 1 [C1102]	Circuit of rear LH wheel sensor is open, shorted or sensor power voltage is unusual.	
FR LH SENSOR 2 [C1108]	ABS actuator and electric unit (control unit) cannot identify sensor pulses, because of large gap between wheel sensor and sensor rotor.	
RR RH SENSOR 2 [C1105]	ABS actuator and electric unit (control unit) cannot identify sensor pulses, because of large gap between wheel sensor and sensor rotor.	
FR RH SENSOR 2 [C1107]	ABS actuator and electric unit (control unit) cannot identify sensor pulses, because of large gap between wheel sensor and sensor rotor.	
RR LH SENSOR 2 [C1106]	ABS actuator and electric unit (control unit) cannot identify sensor pulses, because of large gap between wheel sensor and sensor rotor.	
STOP LAMP SW [C1116]	Stop lamp switch or circuit malfunction.	BRC-76, "Stop Lamp Switch System Inspection"
DECEL G SEN SET [C1160]	ABS decel sensor adjustment is incomplete.	BRC-74, "ABS/ABLS Control Unit Inspection"
FR LH IN ABS SOL [C1120]	Circuit of front LH IN ABS solenoid is open or shorted, or control line is open or shorted to power supply or ground.	BRC-74, "Solenoid and Change-Over Valve System Inspection"
FR LH OUT ABS SOL [C1121]	Circuit of front LH OUT ABS solenoid is open or shorted, or control line is open or shorted to power supply or ground.	
RR RH IN ABS SOL [C1126]	Circuit of rear RH IN ABS solenoid is open or shorted, or control line is open or shorted to power supply or ground.	
RR RH OUT ABS SOL [C1127]	Circuit of rear RH OUT ABS solenoid is open or shorted, or control line is open or shorted to power supply or ground.	
FR RH IN ABS SOL [C1122]	Circuit of front RH IN ABS solenoid is open or shorted, or control line is open or shorted to power supply or ground.	
FR RH OUT ABS SOL [C1123]	Circuit of front RH OUT ABS solenoid is open or shorted, or control line is open or shorted to power supply or ground.	
RR LH IN ABS SOL [C1124]	Circuit of rear LH IN ABS solenoid is open or shorted, or control line is open or shorted to power supply or ground.	
RR LH OUT ABS SOL [C1125]	Circuit of rear LH OUT ABS solenoid is open or shorted, or control line is open or shorted to power supply or ground.	
CV1 [C1164]	Front side switch-over solenoid valve (cut valve) is open or shorted, or control line is open or shorted to power supply or ground.	
CV2 [C1165]	Rear side switch-over solenoid valve (cut valve) is open or shorted, or control line is open or shorted to power supply or ground.	
SV1 [C1166]	Front side switch-over solenoid valve (suction valve) is open or shorted, or control line is open or shorted to power supply or ground.	
SV2 [C1167]	Rear side switch-over solenoid valve (suction valve) is open or shorted, or control line is open or shorted to power supply or ground.	

TROUBLE DIAGNOSIS

[ABLS/ABS]

Self-diagnostic item	Malfunction detecting condition	Check system	
PUMP MOTOR (Note 3) [C1111]	During actuator motor operation with ON, when actuator motor turns OFF or when control line for actuator motor relay is open.	BRC-75. "Actuator Motor, Motor Relay, and Circuit Inspection"	A
	During actuator motor operation with OFF, when actuator motor turns ON or when control line for relay is shorted to ground.		B
BATTERY VOLTAGE [ABNORMAL] [C1109]	ABS actuator and electric unit (control unit) power voltage is too low.	BRC-77. "ABS/ABLS Control Unit Power and Ground Systems Inspection"	C
G-SENSOR [C1113]	G-sensor is malfunctioning.	BRC-74. "ABS/ABLS Control Unit Inspection"	D
CONTROLLER FAILURE [C1110]	Internal malfunction of ABS actuator and electric unit (control unit)		E
CAN COMM CIRCUIT [U1000]	<ul style="list-style-type: none"> ● CAN communication line is open or shorted. ● ABS actuator and electric unit (control unit) internal malfunction ● Battery voltage for ECM is suddenly interrupted for approximately 0.5 second or more. 	BRC-81. "CAN Communication System Inspection" (Note 2)	BRC
BR FLUID LEVEL LOW [C1155]	Brake fluid level drops or circuit between ABS actuator and electric unit (control unit) and brake fluid level switch is open or shorted.	BRC-78. "Brake Fluid Level Switch System Inspection"	G
ENGIN SIGNAL 1 [C1130]	Based on the signal from ECM, ABS actuator and electric unit (control unit) judges that engine fuel cut system is malfunctioning.	BRC-73. "Engine System Inspection"	H
ENGIN SIGNAL 2 [C1131]	Based on the signal from ECM, ABS actuator and electric unit (control unit) judges that engine fuel cut system is malfunctioning.		I
ENGIN SIGNAL 6 [C1136]	Based on the signal from ECM, ABS actuator and electric unit (control unit) judges that engine fuel cut system is malfunctioning.		J
ACTUATOR RLY [C1140]	ABS actuator relay or circuit malfunction.	BRC-75. "Actuator Motor, Motor Relay, and Circuit Inspection"	K
PRESS SEN CIRCUIT [C1142]	ABS pressure sensor circuit malfunction.	BRC-78. "Pressure Sensor System Inspection"	L
ABS VARIANT CODING [C1170]	V coding is not malfunctioning.	BRC-74. "ABS/ABLS Control Unit Inspection"	M
ABS DIFLOCK CONTROLLER NG [C1187]		BRC-81. "CAN Communication System Inspection"	

Note 1: If wheel sensor 2 for each wheel is indicated, check ABS actuator and electric unit (control unit) power supply voltage in addition to wheel sensor circuit check.

Note 2: If multiple malfunctions are detected including CAN communication line [U1000], perform diagnosis for CAN communication line first.

DATA MONITOR

Operation Procedure

1. After turning OFF the ignition switch, connect CONSULT-II and the CONSULT-II CONVERTER to the data link connector.

CAUTION:

If CONSULT-II is used with no connection of CONSULT-II CONVERTER, malfunctions might be detected in self-diagnosis depending on control unit which carries out CAN communication.

2. Touch "START (NISSAN BASED VHCL)", "ABS", "DATA MONITOR" in order on the CONSULT-II screen. If "ABS" is not indicated, go to [GI-38. "CONSULT-II Data Link Connector \(DLC\) Circuit"](#).

TROUBLE DIAGNOSIS

[ABLS/ABS]

CAUTION:

When “START (NISSAN BASED VHCL)” is touched immediately after starting the engine or turning on the ignition switch, “ABS” might not be displayed in the SELECT SYSTEM screen. In this case, repeat the operation from step 2.

3. Return to the SELECT MONITOR ITEM screen, and touch “ECU INPUT SIGNALS”, “MAIN SIGNALS”, or “SELECTION FROM MENU”. Refer to the following information.
4. When “START” is touched, the data monitor screen is displayed.

Display Item List

Item (Unit)	Data monitor item selection			Remarks
	ECU INPUT SIGNALS	MAIN SIGNALS	SELECTION FROM MENU	
GEAR	×	×	×	Gear position judged by PNP switch signal is displayed.
FR RH SENSOR (km/h, MPH)	×	×	×	Wheel speed calculated by front RH wheel sensor signal is displayed.
FR LH SENSOR (km/h, MPH)	×	×	×	Wheel speed calculated by front LH wheel sensor signal is displayed.
RR RH SENSOR (km/h, MPH)	×	×	×	Wheel speed calculated by rear RH wheel sensor signal is displayed.
RR LH SENSOR (km/h, MPH)	×	×	×	Wheel speed calculated by rear LH wheel sensor signal is displayed.
BATTERY VOLT (V)	×	×	×	Voltage supplied to ABS actuator and electric unit (control unit) is displayed.
N POSI SIG	-	-	×	Shift position judged by PNP switch signal.
P POSI SIG	-	-	×	Shift position judged by PNP switch signal.
ACCEL POS SIG (%)	×	-	×	Throttle valve open/close status judged by CAN communication signal is displayed.
ENGINE SPEED (rpm)	×	×	×	Engine speed judged by CAN communication signal is displayed.
STOP LAMP SW (ON/OFF)	×	×	×	Stop lamp switch (ON/OFF) status is displayed.
ABS WARN LAMP (ON/OFF)	-	×	×	ABS warning lamp (ON/OFF) status is displayed.
SLIP LAMP (ON/OFF)	-	×	×	SLIP indicator lamp (ON/OFF) status is displayed.
FR LH IN SOL (ON/OFF)	-	×	×	Front LH IN ABS solenoid (ON/OFF) status is displayed.
FR LH OUT SOL (ON/OFF)	-	×	×	Front LH OUT ABS solenoid (ON/OFF) status is displayed.
RR RH IN SOL (ON/OFF)	-	×	×	Rear RH IN ABS solenoid (ON/OFF) status is displayed.
RR RH OUT SOL (ON/OFF)	-	×	×	Rear RH OUT ABS solenoid (ON/OFF) status is displayed.
FR RH IN SOL (ON/OFF)	-	×	×	Front RH IN ABS solenoid (ON/OFF) status is displayed.
FR RH OUT SOL (ON/OFF)	-	×	×	Front RH OUT ABS solenoid (ON/OFF) status is displayed.
RR LH IN SOL (ON/OFF)	-	×	×	Rear LH IN ABS solenoid (ON/OFF) status is displayed.

TROUBLE DIAGNOSIS

[ABLS/ABS]

Item (Unit)	Data monitor item selection			Remarks
	ECU INPUT SIGNALS	MAIN SIGNALS	SELECTION FROM MENU	
RR LH OUT SOL (ON/OFF)	-	×	×	Rear LH OUT ABS solenoid (ON/OFF) status is displayed.
MOTOR RELAY (ON/OFF)	-	×	×	ABS motor relay signal (ON/OFF) status is displayed.
ACTUATOR RLY (ON/OFF)	-	×	×	ABS actuator relay signal (ON/OFF) status is displayed.
CV1 (ON/OFF)	-	-	×	Front side switch-over solenoid valve (cut valve) (ON/OFF) status is displayed.
CV2 (ON/OFF)	-	-	×	Rear side switch-over solenoid valve (cut-valve) (ON/OFF) status is displayed.
SV1 (ON/OFF)	-	-	×	Front side switch-over solenoid valve (suction valve) (ON/OFF) status is displayed.
SV2 (ON/OFF)	-	-	×	Rear side switch-over solenoid valve (suction valve) (ON/OFF) status is displayed.
TCS FAIL SIG (ON/OFF)	-	-	×	TCS fail signal (ON/OFF) status is displayed.
ABS FAIL SIG (ON/OFF)	-	-	×	ABS fail signal (ON/OFF) status is displayed.
EBD FAIL SIG (ON/OFF)	-	-	×	EBD fail signal (ON/OFF) status is displayed.
FLUID LEV SW (ON/OFF)	×	-	×	Brake fluid level switch (ON/OFF) status is displayed.
EBD SIGNAL (ON/OFF)	-	-	×	EBD operation (ON/OFF) status is displayed.
ABS SIGNAL (ON/OFF)	-	-	×	ABS operation (ON/OFF) status is displayed.
TCS SIGNAL (ON/OFF)	-	-	×	TCS operation (ON/OFF) status is displayed.
EBD WARN LAMP	-	-	×	Brake warning lamp (ON/OFF) status is displayed.
SLCT LVR POSI	×	×	×	Shift position judged by PNP switch signal.
R POSI SIG	-	-	×	Shift position judged by PNP switch signal.
2WD/4WD	-	-	×	It recognizes on software whether it is 2WD and whether it is in 4WD state.
PRESS SENSOR	×	-	×	Brake pressure detected by pressure sensor is displayed.
CRANKING SIG	-	-	×	The input state of the key SW START position signal is displayed.
PRESS SEN 2	-	-	×	Brake pressure detected by pressure sensor is displayed.

×: Applicable
-: Not applicable

ACTIVE TEST

CAUTION:

- Do not perform active test while driving.

A

B

C

D

E

BRC

G

H

I

J

K

L

M

TROUBLE DIAGNOSIS

[ABLS/ABS]

- Make sure to completely bleed air from the brake system.
- The ABS and brake warning lamps turn on during the active test.

Operation Procedure

1. Connect the CONSULT-II and CONSULT-II CONVERTER to the data link connector and start the engine.

CAUTION:

If CONSULT-II is used with no connection of CONSULT-II CONVERTER, malfunctions might be detected in self-diagnosis depending on control unit which carries out CAN communication.

2. Touch "START (NISSAN BASED VHCL)" on the display screen.
3. Touch "ABS".
If "ABS" is not indicated, go to [GI-38, "CONSULT-II Data Link Connector \(DLC\) Circuit"](#) .
4. Touch "ACTIVE TEST".
5. The SELECT TEST ITEM screen is displayed.
6. Touch necessary test item.

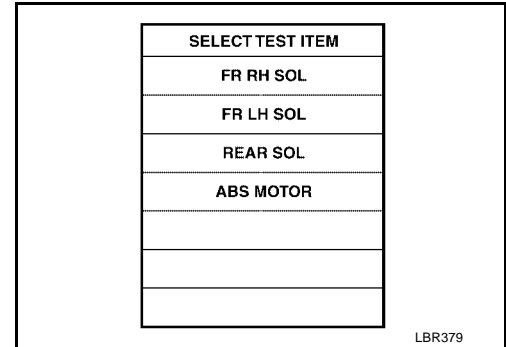

7. With the "MAIN SIGNALS" display selected, touch "START".
8. The Active Test screen will be displayed, so conduct the following test.

Solenoid Valve Operation Chart

Operation		ABS solenoid valve			ABS solenoid valve (ACT)		
		UP	KEEP	DOWN	UP	ACTUA-TOR UP	ACTUA-TOR KEEP
FR RH SOL FR RH ABS SOLE- NOID (ACT)	FR RH IN SOL	OFF	ON	ON	OFF	OFF	OFF
	FR RH OUT SOL	OFF	OFF	ON*	OFF	OFF	OFF
FR LH SOL FR LH ABS SOLE- NOID (ACT)	FR LH IN SOL	OFF	ON	ON	OFF	OFF	OFF
	FR LH OUT SOL	OFF	OFF	ON*	OFF	OFF	OFF
RR RH SOL RR RH ABS SOLE- NOID (ACT)	RR RH IN SOL	OFF	ON	ON	OFF	OFF	OFF
	RR RH OUT SOL	OFF	OFF	ON*	OFF	OFF	OFF
RR LH SOL RR LH ABS SOLE- NOID (ACT)	RR LH IN SOL	OFF	ON	ON	OFF	OFF	OFF
	RR LH OUT SOL	OFF	OFF	ON*	OFF	OFF	OFF
REAR SOL	RR RH IN SOL	OFF	ON	ON	OFF	OFF	OFF
	RR RH OUT SOL	OFF	OFF	ON*	OFF	OFF	OFF
	RR LH IN SOL	OFF	ON	ON	OFF	OFF	OFF
	RR LH OUT SOL	OFF	OFF	ON*	OFF	OFF	OFF

*: ON for 1 to 2 seconds after the touch, and then OFF

NOTE:

- If active test is performed with brake pedal depressed, pedal stroke may change. This is normal.
- "TEST IS STOPPED" is displayed approximately 10 seconds after operation starts.
- After "TEST IS STOPPED" is displayed, to perform test again, repeat Step 6.

TROUBLE DIAGNOSIS

[ABLS/ABS]

ABS Motor

Touch "ON" and "OFF" on the screen. Check that ABS motor relay operates as shown in table below.

Operation	ON	OFF
ABS actuator relay	ON	ON
ABS motor relay	ON	OFF

NOTE:

- If active test is performed with brake pedal depressed, pedal stroke may change. This is normal.
- "TEST IS STOPPED" is displayed approximately 10 seconds after operation starts.

ACTIVE TEST			
ABS MOTOR		OFF	
MONITOR			
MOTOR RELAY		OFF	
ACTUATOR RLY		ON	
ON			
MODE	BACK	LIGHT	COPY

SFIA0593E

A
B
C
D
E
G
H
I
J
K
L
M

BRC

TROUBLE DIAGNOSIS FOR SELF-DIAGNOSTIC ITEMS

PFP:00000

EFS004QZ

Wheel Sensor System Inspection

INSPECTION PROCEDURE

1. CONNECTOR INSPECTION

Disconnect the ABS actuator and electric unit (control unit) connector E125 and wheel sensor of malfunctioning code.

Check the terminals for deformation, disconnection, looseness or damage.

OK or NG

OK >> GO TO 2.

NG >> Repair or replace as necessary.

2. CHECK WHEEL SENSOR OUTPUT SIGNAL

1. Connect ABS active wheel sensor tester (J-45741) to wheel sensor using appropriate adapter.

2. Turn on the ABS active wheel sensor tester power switch.

NOTE:

The green POWER indicator should illuminate. If the POWER indicator does not illuminate, replace the battery in the ABS active wheel sensor tester before proceeding.

3. Spin the wheel of the vehicle by hand and observe the red SENSOR indicator on the ABS active wheel sensor tester. The red SENSOR indicator should flash on and off to indicate an output signal.

NOTE:

If the red SENSOR indicator illuminates but does not flash, reverse the polarity of the tester leads and retest.

Does the ABS active wheel sensor tester detect a signal?

YES >> GO TO 3.

NO >> Replace the wheel sensor. Refer to [BRC-86, "Removal and Installation"](#).

3. CHECK TIRES

Check for inflation pressure, wear and size of each tire.

Are tire pressure and size correct and is tire wear within specifications?

YES >> GO TO 4.

NO >> Adjust tire pressure or replace tire(s).

4. CHECK WHEEL BEARINGS

Check wheel bearing axial end play. Refer to [FAX-5, "WHEEL BEARING INSPECTION"](#) or [RAX-5, "WHEEL BEARING INSPECTION"](#).

OK or NG

OK >> GO TO 5.

NG >> Repair or replace as necessary. Refer to [FAX-5, "Removal and Installation"](#) or [RAX-6, "Removal and Installation"](#).

5. CHECK WIRING HARNESS FOR SHORT CIRCUIT

1. Disconnect ABS actuator and electric unit (control unit) connector and wheel sensor connector of malfunction code No.

2. Check resistance between wheel sensor harness connector terminals and ground.

Continuity should not exist.

OK or NG

OK >> GO TO 6.

NG >> Repair the circuit.

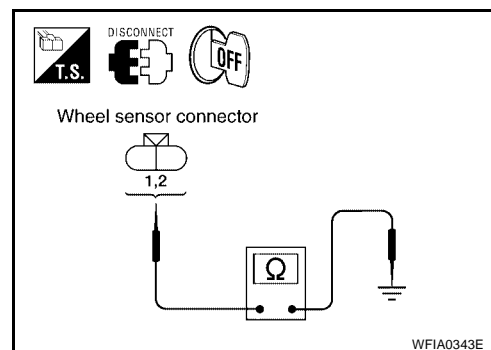

WFIA0343E

TROUBLE DIAGNOSIS FOR SELF-DIAGNOSTIC ITEMS

[ABLS/ABS]

6. CHECK WIRING HARNESS FOR OPEN CIRCUIT

Check continuity between ABS actuator and electric unit (control unit) harness connector E125 and the malfunctioning wheel sensor harness connector E18, E117, C10, or C11.

Wheel sensor	ABS actuator and electric unit (control unit)		Wheel sensor		Continuity
	Connector - terminal	Wire color	Connector - terminal	Wire color	
Front LH	E125 - 45	G/O	E18 - 1	G/O	Yes
	E125 - 46	BR/W	E18 - 2	BR/W	
Front RH	E125 - 34	B/R	E117 - 1	B/R	
	E125 - 33	BR	E117 - 2	BR	
Rear LH	E125 - 37	P	C11 - 2	P	
	E125 - 36	L	C11 - 1	L	
Rear RH	E125 - 42	V	C10 - 2	V	
	E125 - 43	G/Y	C10 - 1	G/Y	

Continuity should exist.

OK or NG

OK >> Replace the ABS actuator and electric unit (control unit). Refer to [BRC-88, "Removal and Installation"](#).

NG >> Repair the circuit.

Engine System Inspection

EFS004R0

INSPECTION PROCEDURE

1. SELF-DIAGNOSIS RESULT CHECK

Check self-diagnosis results.

Self-diagnosis results
ENGINE SIGNAL 1
ENGINE SIGNAL 2
ENGINE SIGNAL 6

Is the above displayed in the self-diagnosis display items?

YES >> GO TO 2.

NO >> Inspection End.

2. ENGINE SYSTEM INSPECTION

1. Perform ECM self-diagnosis and repair as necessary.
2. Perform ABS actuator and electric unit (control unit) self-diagnosis again.

OK or NG

OK >> Inspection End.

NG >> Repair or replace as necessary.

ABS/ABLS Control Unit Inspection

INSPECTION PROCEDURE

1. SELF-DIAGNOSIS RESULT CHECK

Check self-diagnosis results.

Self-diagnosis results
CONTROLLER FAILURE
DECEL G SEN SET
G-SENSOR

Is the above displayed in the self-diagnosis display items?

YES >> Replace ABS actuator and electric unit (control unit). Refer to [BRC-88, "Removal and Installation"](#)

NO >> Inspection End.

Solenoid and Change-Over Valve System Inspection

INSPECTION PROCEDURE

1. SELF-DIAGNOSIS RESULT CHECK

Check self-diagnosis results.

Self-diagnosis results
FR LH IN ABS SOL
FR LH OUT ABS SOL
RR RH IN ABS SOL
RR RH OUT ABS SOL
FR RH IN ABS SOL
FR RH OUT ABS SOL
RR LH IN ABS SOL
RR LH OUT ABS SOL
CV 1
CV 2
SV 1
SV 2

Is the above displayed in the self-diagnosis display items?

YES >> GO TO 2.

NO >> Inspection End.

2. CONNECTOR INSPECTION

1. Disconnect ABS actuator and electric unit (control unit) connector E125.
2. Check the terminals for deformation, disconnection, looseness or damage.

OK or NG

OK >> GO TO 3.

NG >> Repair or replace as necessary.

3. CHECKING SOLENOID POWER AND GROUND

1. Check voltage between ABS actuator and electric unit (control unit) harness connector E125 and body ground.

ABS actuator and electric unit (control unit) harness connector E125	Body ground	Measured value (Approx.)
32 (B/Y)	—	12V

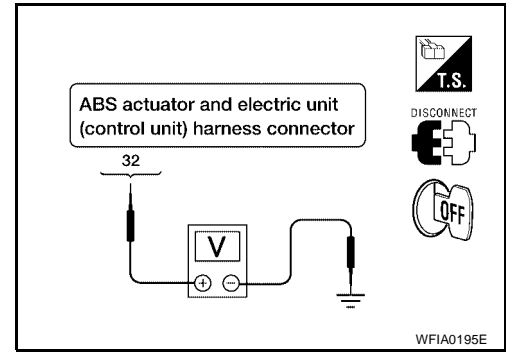

2. Check resistance between ABS actuator and electric unit (control unit) harness connector E125 and body ground.

ABS actuator and electric unit (control unit) harness connector E125	Body ground	Measured value Ω (Approx.)
16 (B)	—	0Ω
47 (B)	—	0Ω

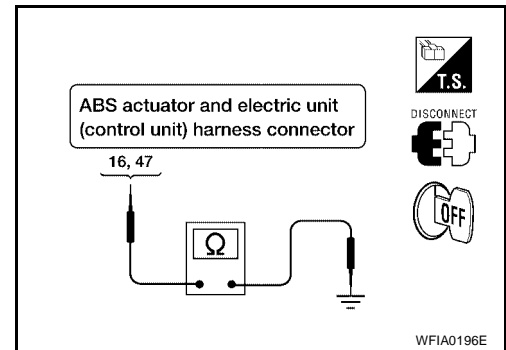

OK or NG

- OK >> Perform self-diagnosis again. If the same results appear, replace ABS actuator and electric unit (control unit). Refer to [BRC-88, "Removal and Installation"](#).
- NG >> Repair the circuit.

Actuator Motor, Motor Relay, and Circuit Inspection

EFS004R3

INSPECTION PROCEDURE

1. CHECKING SELF-DIAGNOSIS RESULTS

Check self-diagnosis results.

Self-diagnosis results
PUMP MOTOR
ACTUATOR RLY

Is the above displayed in the self-diagnosis display items?

- YES >> GO TO 2.
 NO >> Inspection End.

2. CONNECTOR INSPECTION

1. Disconnect ABS actuator and electric unit (control unit) connector E125.
2. Check the terminals for deformation, disconnection, looseness or damage.

OK or NG

- OK >> GO TO 3.
 NG >> Repair or replace as necessary.

A
B
C
D
E
BRC
G
H
I
J
K
L
M

3. CHECKING ABS MOTOR AND MOTOR RELAY POWER SYSTEM

1. Check voltage between ABS actuator and electric unit (control unit) harness connector E125 and body ground.

ABS actuator and electric unit (control unit) harness connector E125	Body ground	Measured value (Approx.)
1 (Y)	—	12V

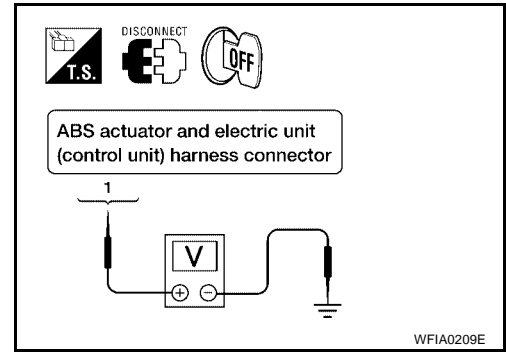

2. Check resistance between ABS actuator and electric unit (control unit) connector E125 and body ground.

ABS actuator and electric unit (control unit) harness connector E125	Body ground	Measured value Ω (Approx.)
16 (B)	—	0Ω
47 (B)	—	0Ω

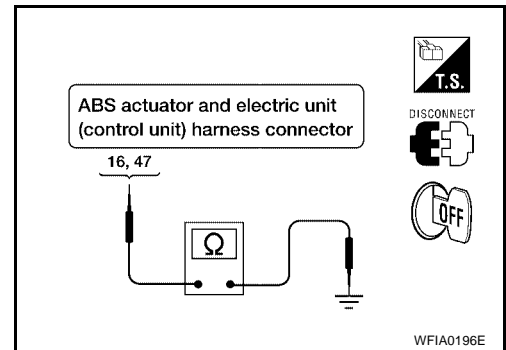

OK or NG

- OK >> Perform self-diagnosis again. If the same results appear, replace ABS actuator and electric unit (control unit). Refer to [BRC-88, "Removal and Installation"](#).
- NG >> Repair the circuit.

Stop Lamp Switch System Inspection

EFS004R4

INSPECTION PROCEDURE

1. SELF-DIAGNOSIS RESULT CHECK

Check self-diagnosis results.

Self-diagnosis results
STOP LAMP SW

Is the above displayed in the self-diagnosis display items?

- YES >> GO TO 2.
- NO >> Inspection End.

2. CONNECTOR INSPECTION

1. Disconnect the ABS actuator and electric unit (control unit) connector E125 and stop lamp switch connector E38.
2. Check the terminals for deformation, disconnection, looseness or damage.

OK or NG

- OK >> GO TO 3.
- NG >> Repair or replace as necessary.

3. STOP LAMP SWITCH INSPECTION

Check the voltage between the ABS actuator and electric unit (control unit) harness connector E125 terminal 41 (V) and body ground.

Brake pedal depressed : Battery voltage (approx. 12V)

Brake pedal not depressed : Approx. 0V

OK or NG

OK >> Perform self-diagnosis again. If the same results appear, replace ABS actuator and electric unit (control unit). Refer to [BRC-88, "Removal and Installation"](#).

NG >> Refer to [LT-98, "STOP LAMP"](#).

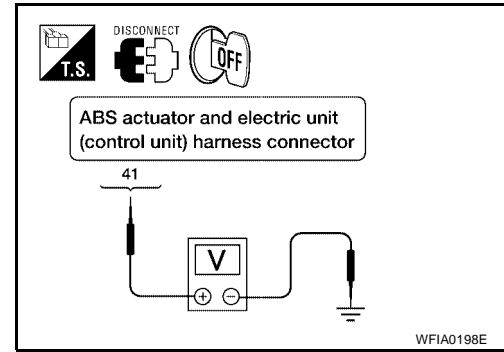

ABS/ABLS Control Unit Power and Ground Systems Inspection

EFS004R5

INSPECTION PROCEDURE

1. SELF-DIAGNOSIS RESULT CHECK

Check self-diagnosis results.

Self-diagnosis results
BATTERY VOLTAGE

Is the above displayed in the self-diagnosis display items?

YES >> GO TO 2.

NO >> Inspection End.

2. CONNECTOR INSPECTION

1. Disconnect the ABS actuator and electric unit (control unit) connector E125.
2. Check the terminals for deformation, disconnection, looseness or damage.

OK or NG

OK >> GO TO 3.

NG >> Repair or replace as necessary.

3. ABS/ABLS CONTROL UNIT POWER AND GROUND CIRCUIT INSPECTION

Measure the voltage and continuity between the ABS actuator and electric unit (control unit) harness connector E125 and body ground.

Signal name	ABS actuator and electric unit (control unit) harness connector E125	Body ground	Measured value
Power supply	1 (Y)	—	Battery voltage (Approx. 12V)
	32 (B/Y)		
Ground	16 (B)	—	Continuity should exist.
	47 (B)		

OK or NG

OK >> Check the battery for loose terminals, low voltage, etc. Repair as necessary.

NG >> Repair the circuit.

Brake Fluid Level Switch System Inspection

INSPECTION PROCEDURE

1. SELF-DIAGNOSIS RESULT CHECK

1. Check the brake reservoir tank fluid level. If the level is low, add brake fluid.
2. Erase the self-diagnosis results and check the self-diagnosis results.

 Self-diagnosis results

 BR FLUID LEVEL LOW

Is the above displayed in the self-diagnosis display items?

- YES >> GO TO 2.
 NO >> Inspection End.

2. CONNECTOR INSPECTION

1. Disconnect the ABS actuator and electric unit (control unit) connector E125 and brake fluid level switch connector E21.
2. Check the terminals for deformation, disconnection, looseness or damage.

OK or NG

- OK >> GO TO 3.
 NG >> Repair or replace as necessary.

3. CHECK THE HARNESS BETWEEN THE BRAKE FLUID LEVEL SWITCH AND THE ABS ACTUATOR AND ELECTRIC UNIT (CONTROL UNIT)

Check the continuity between the brake fluid level switch harness connector E21 and the ABS actuator and electric unit (control unit) harness connector E125.

ABS actuator and electric unit (control unit) harness connector E125	Brake fluid level switch harness connector E21	Continuity
8 (P/B)	1 (P/B)	Yes
8 (P/B)	Ground	No
Ground	2 (B)	Yes

OK or NG

- OK >> Perform self-diagnosis again. If the same results appear, replace ABS actuator and electric unit (control unit). Refer to [BRC-88, "Removal and Installation"](#).
 NG >> Repair the circuit.

Pressure Sensor System Inspection

FRONT PRESSURE INSPECTION PROCEDURE

1. DISPLAY SELF DIAGNOSIS RESULTS

Check self-diagnosis results.

 Self-diagnosis results

 PRESS SEN CIRCUIT

Is the above displayed in the self-diagnosis display items?

YES or NO

- YES >> GO TO 2.
 NO >> Inspection End.

2. CONNECTOR INSPECTION

1. Turn the ignition switch OFF.
2. Disconnect the front pressure sensor connector E31 and ABS actuator and electric unit (control unit) connector E125 and inspect the terminals for deformation, disconnection, looseness, or damage.

OK or NG

- OK >> GO TO 3.
- NG >> Repair connector.

3. FRONT PRESSURE SENSOR CIRCUIT INSPECTION

1. Measure the continuity between the ABS actuator and electric unit (control unit) harness connector E125 and front pressure sensor harness connector E31.

ABS actuator and electric unit (control unit) harness connector E125	Front pressure sensor harness connector E31	Continuity
18 (R/W)	3 (R/W)	Yes
19 (R)	1 (R)	
20 (R/L)	2 (R/L)	

2. Measure the continuity between the ABS actuator and electric unit (control unit) harness connector E125 and body ground.

ABS actuator and electric unit (control unit) harness connector E125	Body ground	Continuity
18 (R/W)	—	No
19 (R)		
20 (R/L)		

OK or NG

- OK >> GO TO 4.
- NG >> Repair or replace harness or connector.

4. FRONT PRESSURE SENSOR INSPECTION

1. Reconnect the front pressure sensor and ABS actuator and electric unit (control unit) connectors.
2. Use "DATA MONITOR" to check if the status of "PRESS SENSOR" is normal.

Condition	Data monitor display (Approx.)
	PRESS SENSOR
When brake pedal is depressed	Positive value
When brake pedal is released	0 bar

OK or NG

- OK >> Inspection End.
- NG >> Replace front pressure sensor. Refer to [BR-17, "REMOVAL AND INSTALLATION"](#) .

TROUBLE DIAGNOSIS FOR SELF-DIAGNOSTIC ITEMS

[ABLS/ABS]

REAR PRESSURE INSPECTION PROCEDURE

1. DISPLAY SELF DIAGNOSIS RESULTS

Check self-diagnosis results.

Self-diagnosis results

PRESS SEN CIRCUIT

Is the above displayed in the self-diagnosis display items?

YES or NO

YES >> GO TO 2.

NO >> Inspection End.

2. CONNECTOR INSPECTION

1. Turn the ignition switch OFF.
2. Disconnect the rear pressure sensor connector E32 and ABS actuator and electric unit (control unit) connector E125 and inspect the terminals for deformation, disconnection, looseness, or damage.

OK or NG

OK >> GO TO 3.

NG >> Repair connector.

3. REAR PRESSURE SENSOR CIRCUIT INSPECTION

1. Measure the continuity between the ABS actuator and electric unit (control unit) connector E125 and rear pressure sensor connector E32.

ABS actuator and electric unit (control unit) connector E125	Rear pressure sensor connector E32	Continuity
21 (R/B)	1 (R/B)	Yes
22 (W/L)	3 (W/L)	
23 (W/O)	2 (W/O)	

2. Measure the continuity between the ABS actuator and electric unit (control unit) connector E125 and body ground.

ABS actuator and electric unit (control unit) connector E125	Body ground	Continuity
21 (R/B)	—	No
22 (W/L)		
23 (W/O)		

OK or NG

OK >> GO TO 4.

NG >> Repair or replace harness or connector.

4. REAR PRESSURE SENSOR INSPECTION

1. Reconnect the rear pressure sensor and ABS actuator and electric unit (control unit) connectors.
2. Use "DATA MONITOR" to check if the status of "PRESS SEN 2" is normal.

Condition	Data monitor display (Approx.)
	PRESS SEN 2
When brake pedal is depressed	Positive value
When brake pedal is released	0 bar

OK or NG

- OK >> Inspection End.
- NG >> Replace rear pressure sensor. Refer to [BR-17, "REMOVAL AND INSTALLATION"](#) .

CAN Communication System Inspection

EFS004R8

INSPECTION PROCEDURE

1. CHECK CONNECTOR

1. Turn ignition switch OFF, disconnect the ABS actuator and electric unit (control unit) connector and check the terminals for deformation, disconnection, looseness, and so on. If there is a malfunction, repair or replace the terminal.
2. Reconnect connector to perform self-diagnosis.

Is "CAN COMM CIRCUIT" displayed in self-diagnosis display items?

- YES >> Print out the self-diagnostic results, and refer to [LAN-7, "CAN COMMUNICATION"](#) .
- NO >> Connector terminal is loose, damaged, open, or shorted.

A
B
C
D
E
G
H
I
J
K
L
M

BRC

TROUBLE DIAGNOSES FOR SYMPTOMS**ABS Works Frequently**

1. CHECK WARNING LAMP ACTIVATION

Make sure warning lamp remains off while driving.

OK or NG

OK >> GO TO 2.

NG >> Carry out self-diagnosis. Refer to [BRC-65, "SELF-DIAGNOSIS"](#) .

2. CHECK WHEEL SENSORS

Check the following.

- Wheel sensor mounting for looseness
- Wheel sensors for physical damage
- Wheel sensor connectors for terminal damage or loose connections
- Sensor rotor and mount for physical damage (rear only)

OK or NG

OK >> GO TO 3.

NG >> Repair or replace as necessary.

3. CHECK FRONT AND REAR AXLES

Check front and rear axles for excessive looseness. Refer to [FAX-5, "WHEEL BEARING INSPECTION"](#) or [RAX-5, "WHEEL BEARING INSPECTION"](#) .

OK or NG

OK >> GO TO 4.

NG >> Repair as necessary.

4. CHECK BRAKE FLUID PRESSURE

Check brake fluid pressure distribution.

Refer to [BRC-60, "Basic Inspection"](#) .

Is brake fluid pressure distribution normal?

YES >> Inspection End.

NO >> Perform Basic Inspection. Refer to [BRC-60, "Basic Inspection"](#) .

Unexpected Pedal Action**1. CHECK WARNING LAMP ACTIVATION**

Make sure warning lamp remains off while driving.

OK or NG

OK >> GO TO 2.

NG >> Carry out self-diagnosis. Refer to [BRC-65, "SELF-DIAGNOSIS"](#) .

2. CHECK BRAKE PEDAL STROKE

Check brake pedal stroke.

Is pedal stroke excessive?

YES >> Perform Basic Inspection. Refer to [BRC-60, "Basic Inspection"](#) .

NO >> GO TO 3.

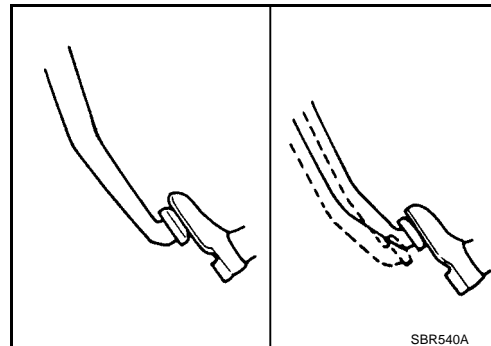
**3. CHECK CONNECTOR AND BRAKING PERFORMANCE**

1. Disable ABS by disconnecting ABS actuator and electric unit (control unit) connector.
2. Drive vehicle and check brake operation.

NOTE:

- Stopping distance may be longer than vehicles without ABS when road condition is slippery.
- Driving the vehicle with the ABS actuator and electric unit (control unit) disconnected may induce DTCs in electrical control units using CAN communication. After the inspection, clear all DTCs. Refer to [LAN-7, "CAN COMMUNICATION"](#) .

OK or NG

OK >> GO TO 4.

NG >> Perform Basic Inspection. Refer to [BRC-60, "Basic Inspection"](#) .

4. CHECK WHEEL SENSORS

Check the following.

- Wheel sensor mounting for looseness
- Wheel sensors for physical damage
- Wheel sensor connectors for terminal damage or loose connections

OK or NG

OK >> Check ABS actuator and electric unit (control unit) connector terminals for deformation, disconnection, looseness or damage. Reconnect ABS actuator and electric unit (control unit) harness connector. Then retest.

NG >> Repair or replace as necessary.

Long Stopping Distance

1. CHECK BASE BRAKING SYSTEM PERFORMANCE

1. Disable ABS by disconnecting ABS actuator and electric unit (control unit) connector.
2. Drive vehicle and check brake operation.

NOTE:

- Stopping distance may be longer than vehicles without ABS when road condition is slippery.
- Driving the vehicle with the ABS actuator and electric unit (control unit) disconnected may induce DTCs in electrical control units using CAN communication. After the inspection, clear all DTCs. Refer to [LAN-7, "CAN COMMUNICATION"](#).

OK or NG

- OK >> Go to [BRC-82, "ABS Works Frequently"](#).
- NG >> Perform Basic Inspection. Refer to [BRC-60, "Basic Inspection"](#).

ABS Does Not Work

CAUTION:

The ABS does not operate when the vehicle speed is 10 km/h (6 MPH) or less.

1. CHECK WARNING LAMP ACTIVATION

Turn ignition switch ON and check for warning lamp activation.

- Warning lamp should activate for approximately 2 seconds after turning the ignition switch ON.

OK or NG

- OK >> Carry out self-diagnosis. Refer to [BRC-65, "SELF-DIAGNOSIS"](#).
- NG >> Go to [BRC-85, "ABS Warning Lamp Does Not Come On When Ignition Switch Is Turned On"](#).

Pedal Vibration or ABS Operation Noise

NOTE:

During ABS activation, pedal vibration may be felt and a noise may be heard. This is normal and does not indicate a malfunction.

1. CHECK SYMPTOM

1. Apply brake.
2. Start engine.

Does the symptom occur only when engine is started?

- YES >> Carry out self-diagnosis. Refer to [BRC-65, "SELF-DIAGNOSIS"](#).
- NO >> GO TO 2.

2. RECHECK SYMPTOM

Does the symptom occur only when electrical equipment switches (such as headlamps) are turned on?

- YES >> Check for radio, antenna or related wiring that is routed too close to the ABS actuator and electric unit (control unit) and reroute as necessary.
- NO >> Go to [BRC-82, "ABS Works Frequently"](#).

ABS Warning Lamp Does Not Come On When Ignition Switch Is Turned On EFS005FO**1. CHECK ABS ACTUATOR AND ELECTRIC UNIT (CONTROL UNIT) FUSES**

Check 30A fusible link **h** and 40A fusible link **i** for ABS actuator and electric unit (control unit). For fusible link layout, refer to [PG-4, "POWER SUPPLY ROUTING CIRCUIT"](#).

OK or NG

OK >> GO TO 2.

NG >> If fusible link is blown, be sure to eliminate cause of problem before replacing.

2. CHECK ABS ACTUATOR AND ELECTRIC UNIT (CONTROL UNIT) POWER SUPPLY CIRCUITS

1. Disconnect ABS actuator and electric unit (control unit) connector.
2. Check voltage between ABS actuator and electric unit (control unit) connector terminal 1 (Y) and ground and terminal 32 (B/Y) and ground.

Does battery voltage exist?

YES >> GO TO 3.

NO >> Repair harness or connectors between fusible link and ABS actuator and electric unit (control unit).

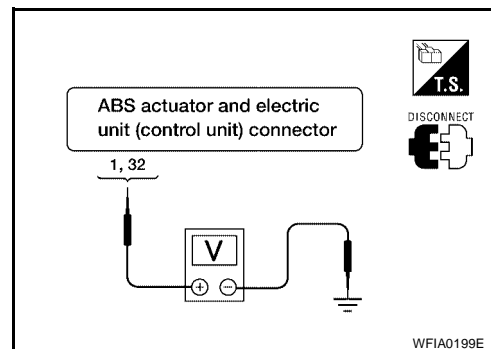
**3. CHECK ABS ACTUATOR AND ELECTRIC UNIT (CONTROL UNIT) GROUND CIRCUIT**

Check continuity between ABS actuator and electric unit (control unit) connector terminal 16 (B) and ground and terminal 47 (B) and ground.

Does continuity exist?

YES >> Replace ABS actuator and electric unit (control unit). Refer to [BRC-88, "Removal and Installation"](#).

NO >> Repair harness or connectors between ABS actuator and electric unit (control unit) and ground.

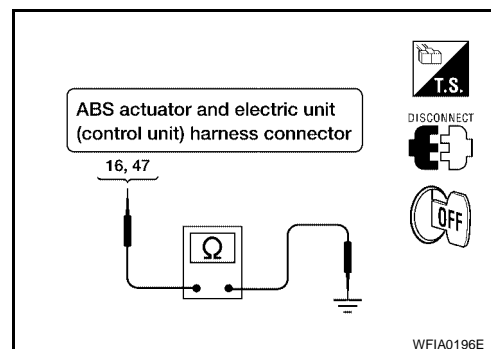
**ABS Warning Lamp Stays On When Ignition Switch Is Turned On** EFS005FR**1. CARRY OUT SELF-DIAGNOSIS**

Carry out self-diagnosis. Refer to [BRC-65, "SELF-DIAGNOSIS"](#).

Are malfunctions detected in self-diagnosis?

YES >> Refer to [BRC-66, "Display Item List"](#).

NO >> Refer to [DI-30, "WARNING LAMPS"](#).

WHEEL SENSORS

Removal and Installation

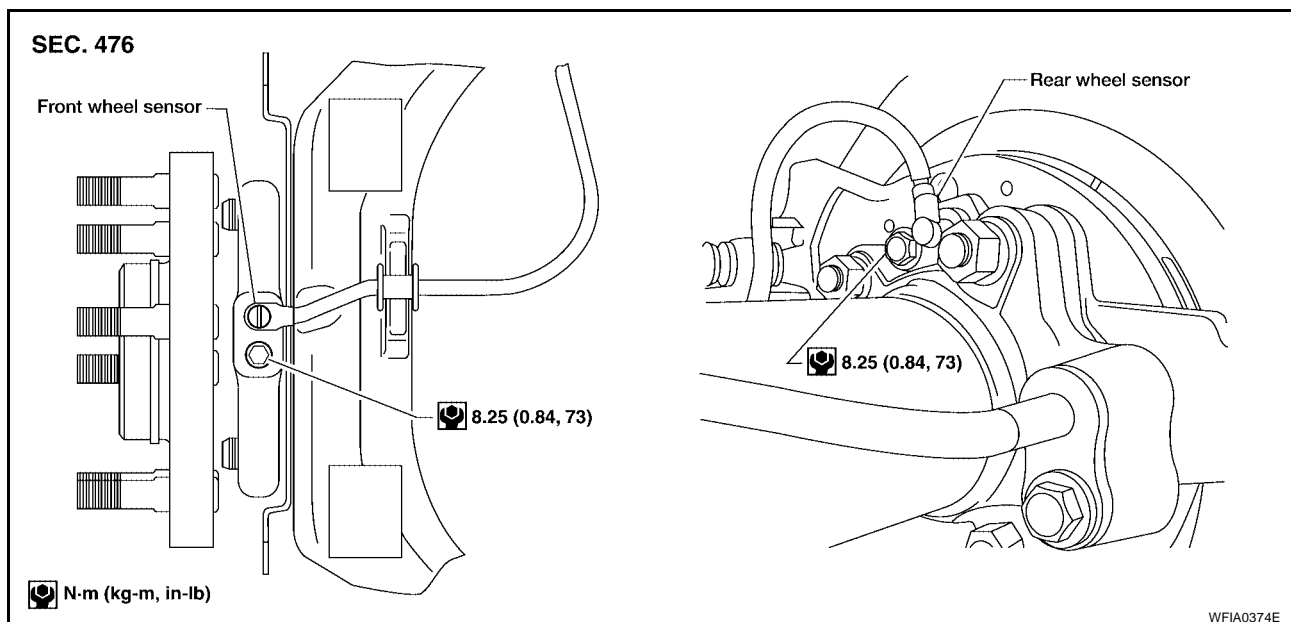

REMOVAL

1. Remove wheel sensor mounting screw.
 - When removing the front wheel sensor, first remove the disc rotor to gain access to the front wheel sensor mounting bolt. Refer to [BR-24, "Removal and Installation of Brake Caliper and Disc Rotor"](#).
2. Pull out the sensor, being careful to turn it as little as possible.

CAUTION:

- Be careful not to damage sensor edge and sensor rotor teeth.
 - Do not pull on the sensor harness.
3. Disconnect wheel sensor harness electrical connector, then remove harness from mounts.

INSTALLATION

Before installing wheel sensors,

- Inspect wheel sensor O-ring, replace sensor assembly if damaged.
- Clean wheel sensor hole and mounting surface with brake cleaner and a lint-free shop rag. Be careful that dirt and debris do not enter the axle.
- Apply a coat of suitable grease to the wheel sensor O-ring and mounting hole.

Installation is in the reverse order of removal.

SENSOR ROTOR

PFP:47970

Removal and Installation FRONT

EFS004RH

The wheel sensor rotors are built into the wheel hubs and are not removable. If damaged, replace wheel hub and bearing assembly. Refer to [FAX-5, "Removal and Installation"](#) .

REAR

Removal

1. Remove axle shaft assembly. Refer to [RAX-6, "Removal and Installation"](#) .

NOTE:

It is necessary to disassemble the rear axle to replace the sensor rotor.

2. Pull the sensor rotor of off the axle shaft using Tool and a press.

Tool number : 205-D002 (—)

Installation

1. Install new sensor rotor on axle shaft using a suitable length steel tube and a press. Make sure sensor rotor is fully seated.

CAUTION:

Do not reuse the old sensor rotor.

2. Install axle shaft assembly. Refer to [RAX-6, "Removal and Installation"](#) .

CAUTION:

Do not reuse the axle oil seal. The axle oil seal must be replaced every time the axle shaft assembly is removed from the axle shaft housing.

A
B
C
D
E
G
H
I
J
K
L
M

BRC

ACTUATOR AND ELECTRIC UNIT (ASSEMBLY)

PFP:47660

Removal and Installation

EFS004RI

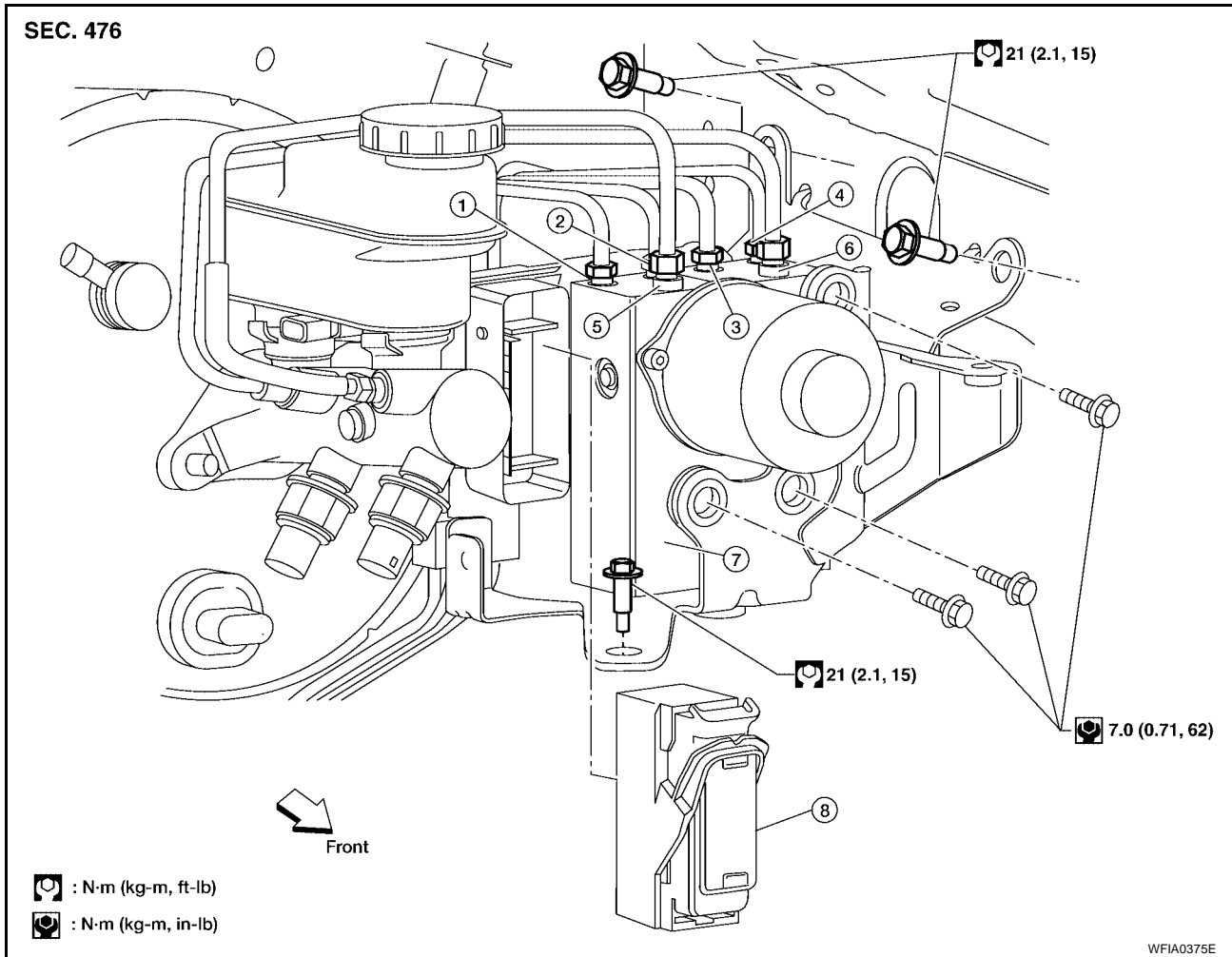

- | | | |
|--|--|--|
| 1. To rear left | 2. To rear right | 3. To front left |
| 4. To front right | 5. From the master cylinder secondary side | 6. From the master cylinder primary side |
| 7. ABS actuator and electric unit (control unit) | 8. Harness connector | |

REMOVAL

1. Disconnect the negative battery terminal.
2. Remove the cowl top extension. Refer to [EI-21, "Removal and Installation"](#).
3. Drain the brake fluid. Refer to [BR-10, "Drain and Refill"](#).
4. Disconnect the actuator harness from the ABS actuator and electric unit (control unit).

CAUTION:

- To remove the brake tubes, use a flare nut wrench to prevent the flare nuts and brake tubes from being damaged.
- Be careful not to splash brake fluid on painted areas.

5. Disconnect the brake tubes.
6. Remove the three bolts and remove the ABS actuator and electric unit (control unit).

INSTALLATION

Installation is in the reverse order of removal.

CAUTION:

To install, use a flare nut wrench (commercial service tool).

- Always tighten brake tubes to specification when installing. Refer to [BR-12, "BRAKE PIPING AND HOSE"](#) .
- Never reuse drained brake fluid.
- After installation of the ABS actuator and electric unit (control unit), refill brake system with new brake fluid. Then bleed the air from the system. Refer to [BR-11, "Bleeding Brake System"](#) .

A

B

C

D

E

BRC

G

H

I

J

K

L

M

PRECAUTIONS

PF0:0001

Precautions for Supplemental Restraint System (SRS) “AIR BAG” and “SEAT BELT PRE-TENSIONER”

EFS004RJ

The Supplemental Restraint System such as “AIR BAG” and “SEAT BELT PRE-TENSIONER”, used along with a front seat belt, helps to reduce the risk or severity of injury to the driver and front passenger for certain types of collision. Information necessary to service the system safely is included in the SRS and SB section of this Service Manual.

WARNING:

- To avoid rendering the SRS inoperative, which could increase the risk of personal injury or death in the event of a collision which would result in air bag inflation, all maintenance must be performed by an authorized NISSAN/INFINITI dealer.
- Improper maintenance, including incorrect removal and installation of the SRS, can lead to personal injury caused by unintentional activation of the system. For removal of Spiral Cable and Air Bag Module, see the SRS section.
- Do not use electrical test equipment on any circuit related to the SRS unless instructed to in this Service Manual. SRS wiring harnesses can be identified by yellow and/or orange harnesses or harness connectors.

Precautions for Brake System

EFS004RK

CAUTION:

- Refer to [MA-11, "RECOMMENDED FLUIDS AND LUBRICANTS"](#) for recommended brake fluid.
- Never reuse drained brake fluid.
- Be careful not to splash brake fluid on painted areas; it may cause paint damage. If brake fluid is splashed on painted areas, wash it away with water immediately.
- To clean or wash all parts of master cylinder and disc brake caliper, use clean brake fluid.
- Never use mineral oils such as gasoline or kerosene. They will ruin rubber parts of the hydraulic system.
- Use flare nut wrench when removing and installing brake tube.
- If a brake fluid leak is found, the part must be disassembled without fail. Then it has to be replaced with a new one if a defect exists.
- Turn the ignition switch OFF and remove the connector of the ABS actuator and electric unit (control unit) or the battery terminal before performing the work.
- Always torque brake lines when installing.
- Burnish the brake contact surfaces after refinishing or replacing rotors, after replacing pads, or if a soft pedal occurs at very low mileage.

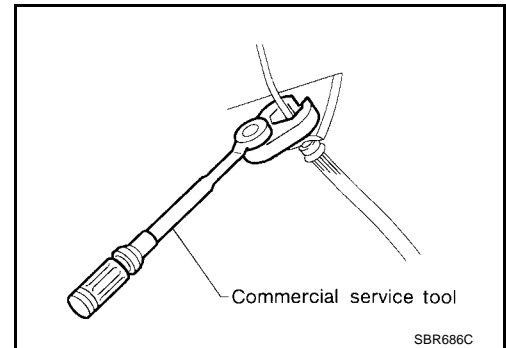

Refer to [BR-27, "BRAKE BURNISHING PROCEDURE"](#) (front disc brake) or [BR-32, "BRAKE BURNISHING PROCEDURE"](#) (rear disc brake).

WARNING:

- Clean brake pads and shoes with a waste cloth, then wipe with a dust collector.

Precautions When Using CONSULT-II

EFS004RL

When connecting CONSULT-II to data link connector, connect them through CONSULT-II CONVERTER.

CAUTION:

If CONSULT-II is used with no connection of CONSULT-II CONVERTER, malfunctions might be detected in self-diagnosis depending on control unit which carries out CAN communication.

CHECK POINTS FOR USING CONSULT-II

1. Has CONSULT-II been used without connecting CONSULT-II CONVERTER on this vehicle?
 - If YES, GO TO 2.
 - If NO, GO TO 5.

PRECAUTIONS

[VDC/TCS/ABS]

2. Is there any indication other than indications relating to CAN communication system in the self-diagnosis results?
 - If YES, GO TO 3.
 - If NO, GO TO 4.
3. Based on self-diagnosis results unrelated to CAN communication, carry out the inspection.
4. Malfunctions may be detected in self-diagnosis depending on control units carrying out CAN communication. Therefore, erase the self-diagnosis results.
5. Diagnose CAN communication system. Refer to [LAN-7, "CAN COMMUNICATION"](#).

Precautions for Brake Control

EFS004RM

- During ABS operation, the brake pedal may vibrate lightly and a mechanical noise may be heard. This is normal.
- Just after starting vehicle, the brake pedal may vibrate or a motor operating noise may be heard from engine compartment. This is a normal status of operation check.
- Stopping distance may be longer than that of vehicles without ABS when vehicle drives on rough, gravel, or snow-covered (fresh, deep snow) roads.
- When an error is indicated by ABS or another warning lamp, collect all necessary information from customer (what symptoms are present under what conditions) and check for simple causes before starting diagnosis. Besides electrical system inspection, check brake booster operation, brake fluid level, and fluid leaks.
- If incorrect tire sizes or types are installed on the vehicle or brake pads are not Genuine NISSAN parts, stopping distance or steering stability may deteriorate.
- If there is a radio, antenna or related wiring near control module, ABS function may have a malfunction or error.
- If aftermarket parts (car stereo, CD player, etc.) have been installed, check for incidents such as harness pinches, open circuits or improper wiring.
- If the following components are replaced with non-genuine components or modified, the VDC OFF indicator lamp and SLIP indicator lamp may turn on or the VDC system may not operate properly. Components related to suspension (shock absorbers, struts, springs, bushings, etc.), tires, wheels (exclude specified size), components related to brake system (pads, rotors, calipers, etc.), components related to engine (muffler, ECM, etc.), components related to body reinforcement (roll bar, tower bar, etc.).
- Driving with broken or excessively worn suspension components, tires or brake system components may cause the VDC OFF indicator lamp and the SLIP indicator lamp to turn on, and the VDC system may not operate properly.
- When the TCS or VDC is activated by sudden acceleration or sudden turn, some noise may occur. The noise is a result of the normal operation of the TCS and VDC.
- When driving on roads which have extreme slopes (such as mountainous roads) or high banks (such as sharp curves on a freeway), the VDC may not operate normally, or the VDC warning lamp and the SLIP indicator lamp may turn on. This is not a problem if normal operation can be resumed after restarting the engine.
- Sudden turns (such as spin turns, acceleration turns), drifting, etc. with VDC turned off may cause the yaw rate/side G sensor to indicate a problem. This is not a problem if normal operation can be resumed after restarting the engine.

Precautions for CAN System

EFS004RN

- Do not apply voltage of 7.0V or higher to terminal to be measured.
- Maximum open terminal voltage of tester in use must be less than 7.0V.
- Before checking harnesses, turn ignition switch OFF and disconnect battery negative cable.

PRECAUTIONS

[VDC/TCS/ABS]

- Area to be repaired must be soldered and wrapped with tape. Make sure that fraying of twisted wire is within 110 mm (4.33 in).

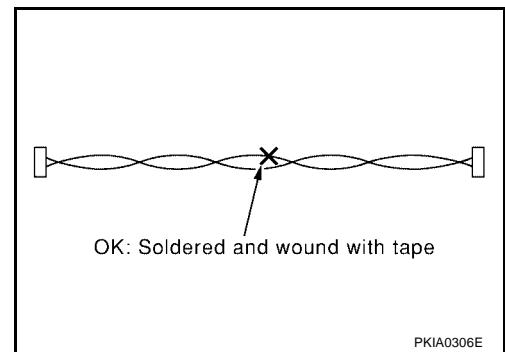

- Do not make a bypass connection to repaired area. (If the circuit is bypassed, characteristics of twisted wire will be lost.)

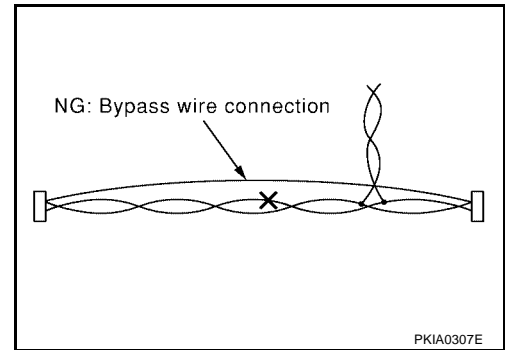

Wiring Diagrams and Trouble Diagnosis

When you read wiring diagrams, refer to the following:

- [GI-14, "How to Read Wiring Diagrams"](#).
- [PG-4, "POWER SUPPLY ROUTING CIRCUIT"](#).

When you perform trouble diagnosis, refer to the following:

- [GI-11, "HOW TO FOLLOW TEST GROUPS IN TROUBLE DIAGNOSES"](#).
- [GI-27, "How to Perform Efficient Diagnosis for an Electrical Incident"](#).

PREPARATION

[VDC/TCS/ABS]

PREPARATION

PF0:00002

Special Service Tool

EFS004RP

The actual shapes of Kent-Moore tools may differ from those of special service tools illustrated here.

Tool number (Kent-Moore No.) Tool name	Description
(J-45741) ABS active wheel sensor tester	Checking operation of ABS active wheel sensors
205-D002 (—) Bearing splitter	Removing axle shaft bearing

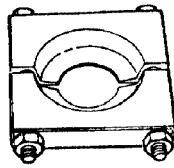
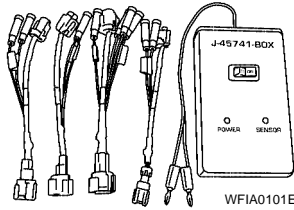

Commercial Service Tools

EFS004RQ

Tool name	Description
1. Flare nut crowfoot 2. Torque wrench	Removing and installing brake piping a: 10mm (0.39 in)/12mm (0.47 in)

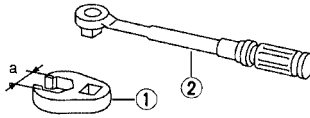

A
B
C
D
E
BRC
G
H
I
J
K
L
M

SYSTEM DESCRIPTION

System Components

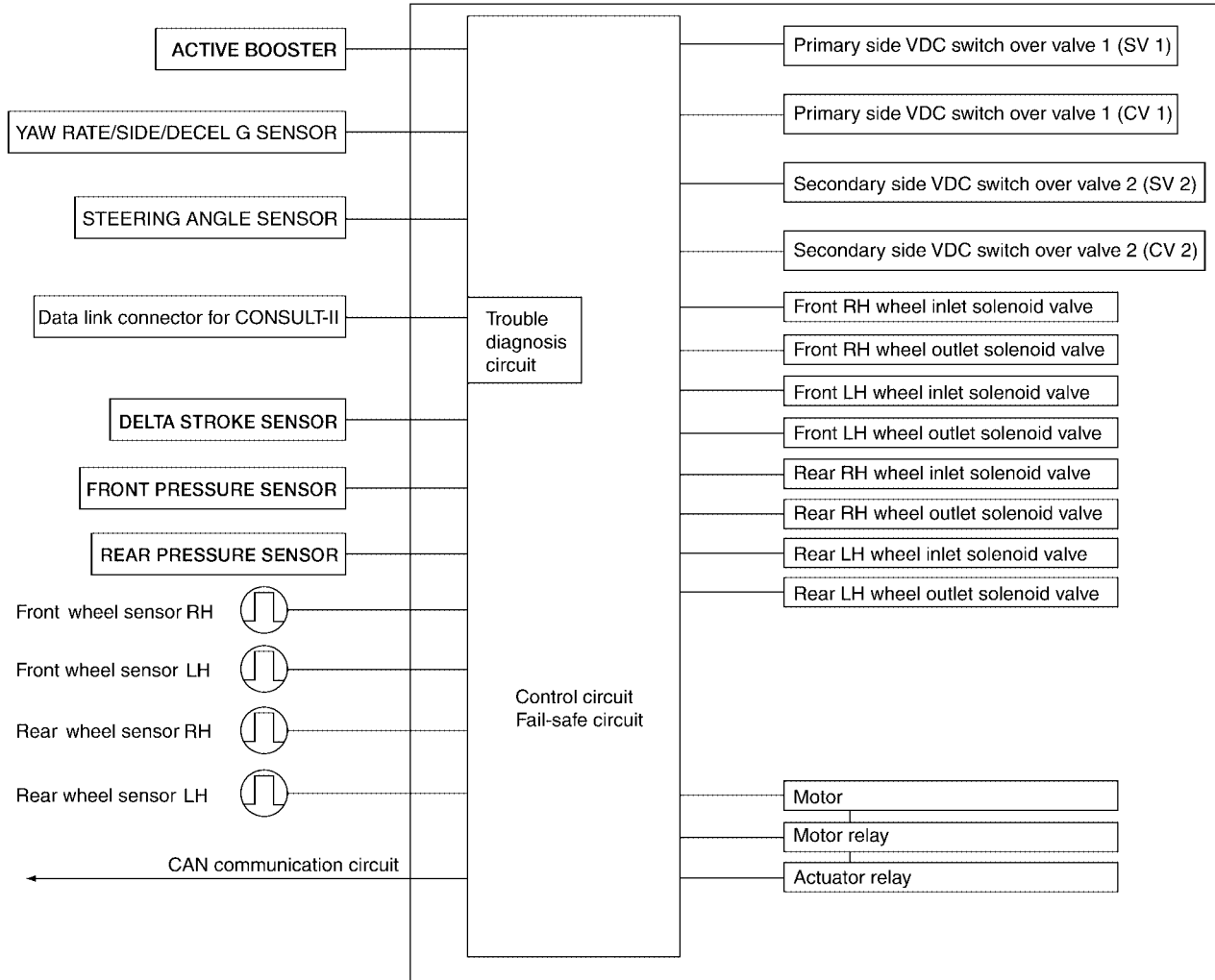

ABS actuator and electric unit (control unit)

ABS Function

EFS004RS

- The Anti-Lock Brake System detects wheel revolution while braking and improves handling stability during sudden braking by electrically preventing wheel lockup. Maneuverability is also improved for avoiding obstacles.
- If the electrical system malfunctions, the Fail-Safe function is activated, the ABS becomes inoperative and the ABS warning lamp turns on.
- The electrical system can be diagnosed using CONSULT-II.
- During ABS operation, the brake pedal may vibrate lightly and a mechanical noise may be heard. This is normal.
- Just after starting the vehicle, the brake pedal may vibrate or a motor operating noise may be heard from engine compartment. This is a normal status of operation check.
- Stopping distance may be longer than that of vehicles without ABS when vehicle drives on rough, gravel, or snow-covered (fresh, deep snow) roads.

EBD Function

EFS004RT

- Electronic Brake Distribution is a function that detects subtle slippages between the front and rear wheels during braking, and it improves handling stability by electronically controlling the brake fluid pressure which results in reduced rear wheel slippage.
- If the electrical system malfunctions, the Fail-Safe function is activated, the EBD and ABS become inoperative, and the ABS warning lamp and BRAKE warning lamp are turned on.
- The electrical system can be diagnosed using CONSULT-II.
- During EBD operation, the brake pedal may vibrate lightly and a mechanical noise may be heard. This is normal.
- Just after starting the vehicle, the brake pedal may vibrate or a motor operating noise may be heard from engine compartment. This is a normal status of operation check.

TCS Function

EFS004RU

- Spinning of the drive wheels is detected by the ABS actuator and electric unit (control unit) using inputs from the wheel speed sensors. If wheel spin occurs, the drive wheel right and left brake fluid pressure control and engine fuel cut are activated while the throttle value is restricted to reduce the engine torque and decrease the amount of wheel spin. In addition, the throttle opening is controlled to achieve the optimum engine torque.
- Depending on road condition, the vehicle may have a sluggish feel. This is normal, because optimum traction has the highest priority during TCS operation.
- TCS may be activated during sudden vehicle acceleration, wide open throttle acceleration, sudden transmission shifts or when the vehicle is driven on a road with a varying surface friction coefficient.
- The SLIP indicator lamp flashes to inform the driver of TCS operation.

VDC Function

EFS004RV

- In addition to the ABS/TCS function, the driver steering amount and brake operation amount are detected from the steering angle sensor and pressure sensors, and the vehicle's driving status (amount of under steering/over steering) is determined using inputs from the yaw rate sensor/side G sensor, wheel speed sensors, etc. and this information is used to improve vehicle stability by controlling the braking and engine torque application to the wheels.
- The SLIP indicator lamp flashes to inform the driver of VDC operation.
- During VDC operation, the vehicle body and brake pedal may vibrate lightly and a mechanical noise may be heard. This is normal.
- The ABS warning lamp, VDC OFF indicator lamp and SLIP indicator lamp may turn on when the vehicle is subject to strong shaking or large vibration, such as when the vehicle is on a turn table or a ship while the engine is running or on a steep slope. In this case, restart the engine on a normal road and if the ABS warning lamp, VDC OFF indicator lamp and SLIP indicator lamp turn off, there is no problem.

Fail-Safe Function

EFS004RW

CAUTION:

If the Fail-Safe function is activated, perform the Self Diagnosis for ABS/TCS/VDC system.

ABS/EBD SYSTEM

In case of an electrical malfunction with the ABS, the ABS warning lamp, VDC OFF indicator lamp and SLIP indicator lamp will turn on. In case of an electrical malfunction with the EBD system, the BRAKE warning lamp, ABS warning lamp, VDC OFF indicator lamp and SLIP indicator lamp will turn on. The system will revert to one of the following conditions of the Fail-Safe function.

1. For ABS malfunction, only the EBD is operative and the condition of the vehicle is the same condition of vehicles without ABS/TCS/VDC system.
2. For EBD malfunction, the EBD and ABS become inoperative, and the condition of the vehicle is the same as the condition of vehicles without ABS/TCS/VDC or EBD system.

VDC/TCS SYSTEM

In case of TCS/VDC system malfunction, the VDC OFF indicator lamp and SLIP indicator lamp are turned on and the condition of the vehicle is the same as the condition of vehicles without TCS/VDC system. In case of an electrical malfunction with the TCS/VDC system, the ABS control continues to operate normally without TCS/VDC control.

ACTIVE BOOSTER

The active brake booster consists of vacuum booster, an active booster control group and a delta stroke sensor. In case of brake booster system malfunction due to loss of vacuum the delta stroke sensor will signal the ABS actuator and electric unit (control unit) that a booster failure has occurred. The active booster then applies supplemental force to the master cylinder relative to the amount of force exerted on the brake pedal.

Hydraulic Circuit Diagram

EFS004RX

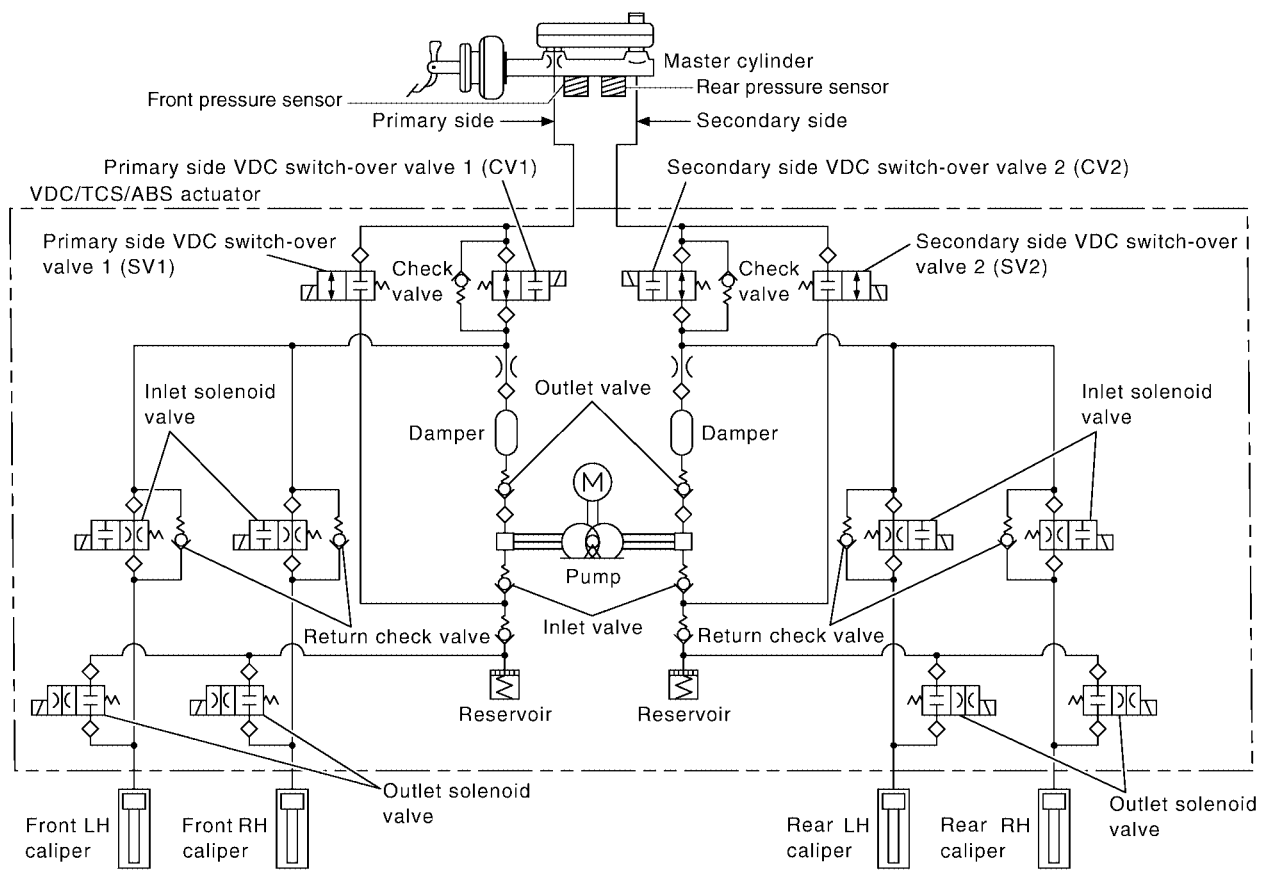

WFIA0187E

CAN COMMUNICATION

PF2:23710

System Description

EF004RY

Refer to [LAN-7, "CAN COMMUNICATION"](#) .

A

B

C

D

E

BRC

G

H

I

J

K

L

M

TROUBLE DIAGNOSIS**How to Perform Trouble Diagnoses for Quick and Accurate Repair**

EFS004RZ

INTRODUCTION

The ABS/TCS/VDC system has an electronic control unit to control major functions. The control unit accepts input signals from sensors and controls actuator operation. It is also important to check for conventional problems such as air leaks in the booster or lines, lack of brake fluid, or other problems with the brake system.

It is much more difficult to diagnose a problem that occurs intermittently rather than continuously. Most intermittent problems are caused by poor electrical connections or faulty wiring. In this case, careful checking of suspicious circuits may help prevent the replacement of good parts.

A visual check only may not find the cause of the problem, so a road test should be performed.

Before undertaking actual checks, take just a few minutes to talk with a customer who approaches with an ABS/TCS/VDC complaint. The customer is a very good source of information on such problems, especially intermittent ones. Through the talks with the customer, find out what symptoms are present and under what conditions they occur.

Start your diagnosis by looking for "conventional" problems first. This is one of the best ways to troubleshoot brake problems on an ABS/TCS/VDC equipped vehicle. Also check related Service Bulletins for information.

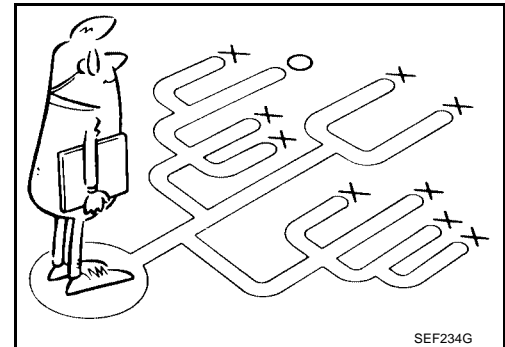
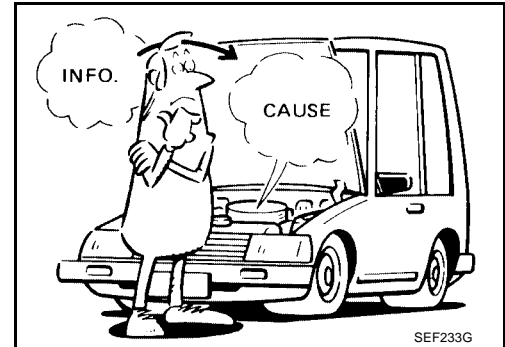

WORK FLOW

A
B
C
D
E
BRC
G
H
I
J
K
L
M

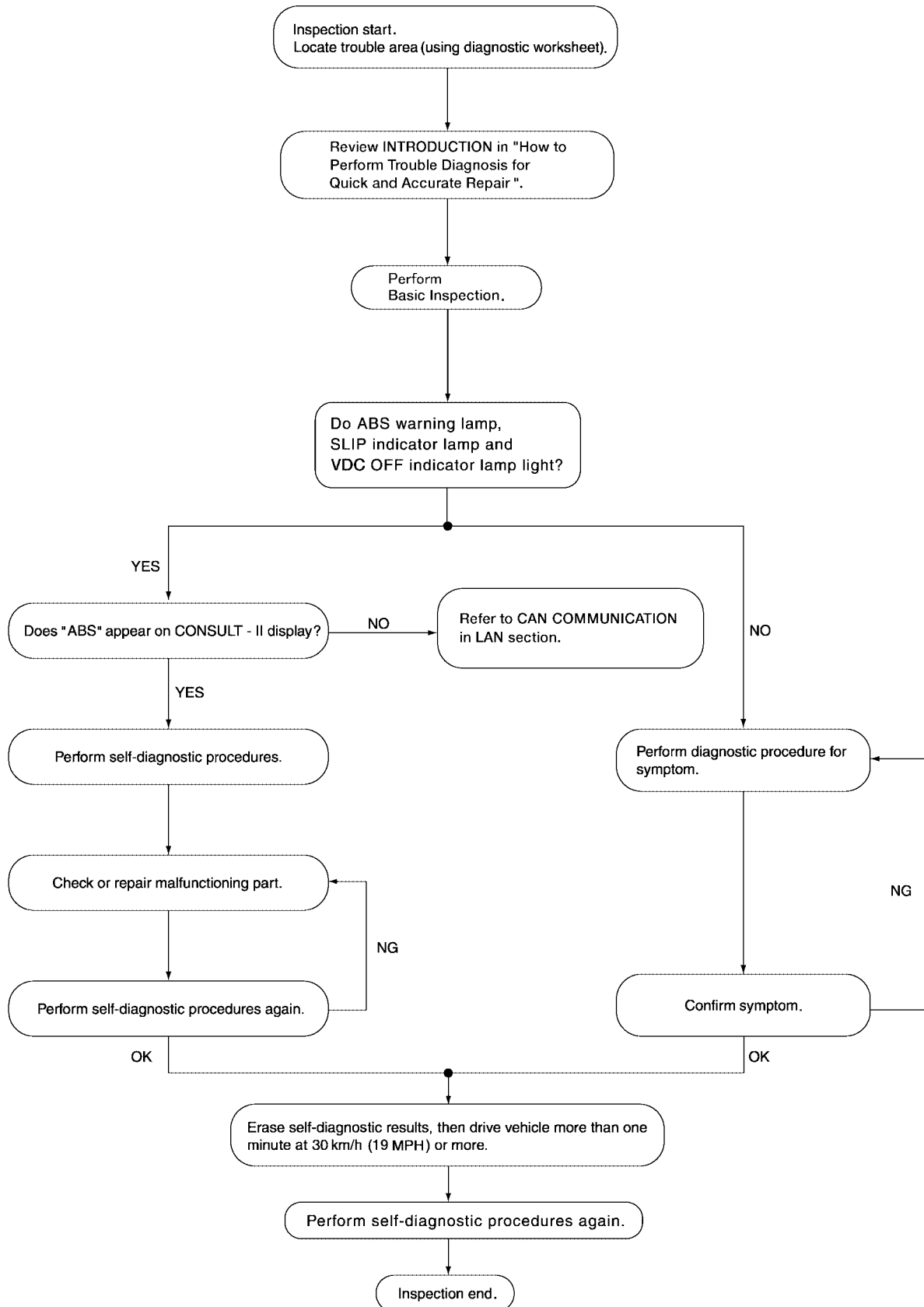

WFIA0358E

TROUBLE DIAGNOSIS

[VDC/TCS/ABS]

CLARIFY CONCERN

- A customer's description of a vehicle concern may vary depending on the individual. It is important to clarify the customer's concern.
- Ask the customer about what symptoms are present under what conditions. Use this information to reproduce the symptom while driving.
- It is also important to use the diagnosis sheet to understand what type of trouble the customer is having.

KEY POINTS	
WHAT Vehicle model
WHEN Date, Frequencies
WHERE Road conditions
HOW Operating conditions, Weather conditions, Symptoms

SBR339B

EXAMPLE OF DIAGNOSIS SHEET

Customer name	Model & Year	VIN	
Engine #	Trans.	Mileage	
Incident Date	Manuf. Date	In Service Date	
Symptoms	<input type="checkbox"/> Noise and vibration (from engine compartment)	<input type="checkbox"/> ABS warning lamp activates	<input type="checkbox"/> Pedal operation
	<input type="checkbox"/> Noise and vibration (from axle)	<input type="checkbox"/> SLIP warning lamp activates	<input type="checkbox"/> Large stroke pedal operation
	<input type="checkbox"/> TCS does not work (drive wheels slip when accelerating)	<input type="checkbox"/> ABS does not work (wheels slip when braking)	<input type="checkbox"/> Firm pedal
	<input type="checkbox"/> Lack of sense of acceleration		
Engine conditions	<input type="checkbox"/> When starting <input type="checkbox"/> After starting		
Road conditions	<input type="checkbox"/> Low friction road (<input type="checkbox"/> Snow <input type="checkbox"/> Gravel <input type="checkbox"/> Other) <input type="checkbox"/> Bumps/potholes		
Driving conditions	<input type="checkbox"/> Full-acceleration <input type="checkbox"/> High speed cornering <input type="checkbox"/> Vehicle speed: Greater than 10 km/h (6 MPH) <input type="checkbox"/> Vehicle speed: 10 km/h (6 MPH) or less <input type="checkbox"/> Vehicle is stopped		
Applying brake conditions	<input type="checkbox"/> Suddenly <input type="checkbox"/> Gradually		
Other conditions	<input type="checkbox"/> Operation of electrical equipment <input type="checkbox"/> Shift change <input type="checkbox"/> Other descriptions		

WFIA0097E

Component Parts and Harness Connector Location

EFS004S0

A
B
C
D
E
BRC
G
H
I
J
K
L
M

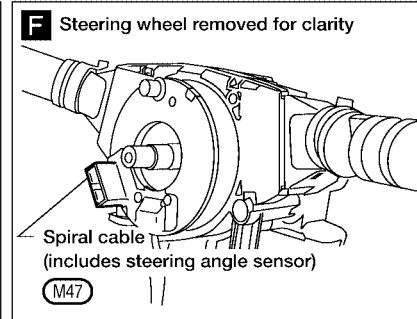
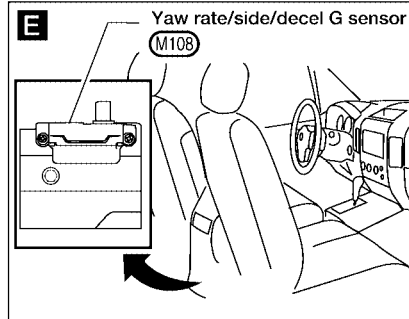
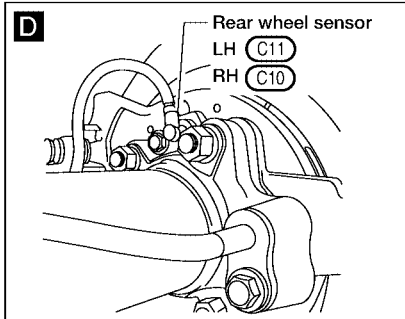
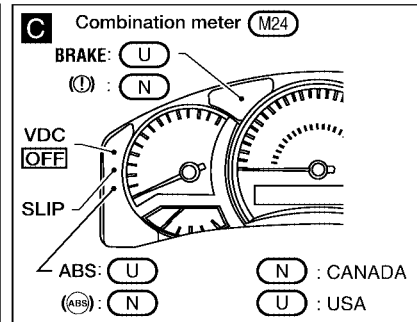
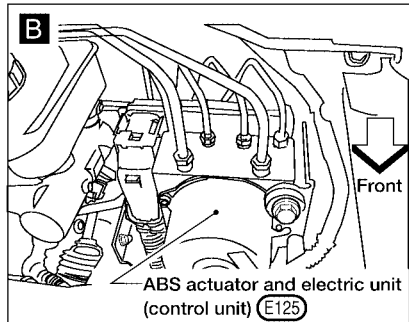
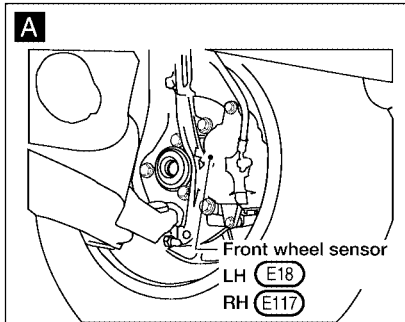
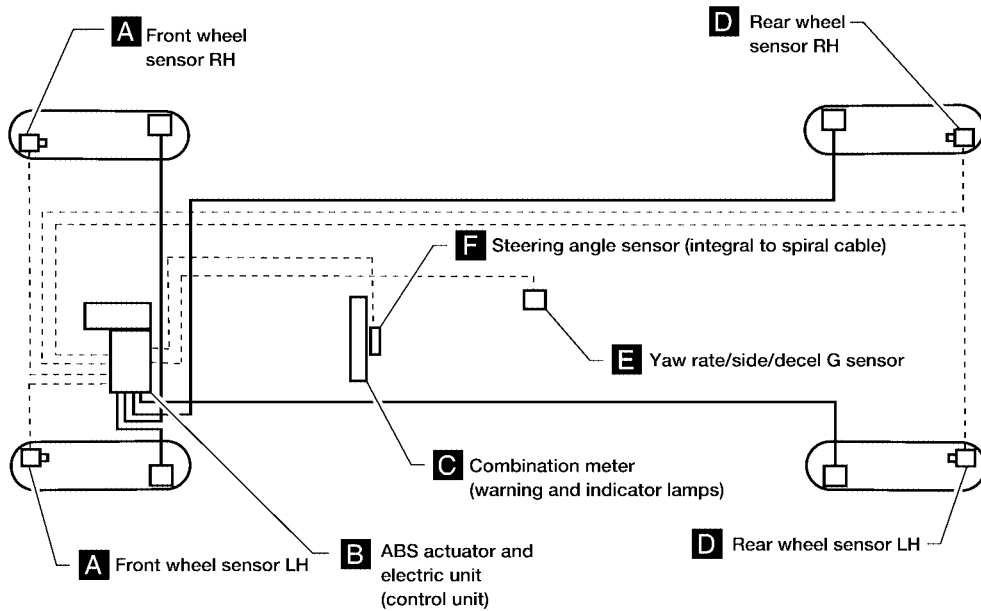

WFIA0373E

TROUBLE DIAGNOSIS

[VDC/TCS/ABS]

Schematic

EFS004S1

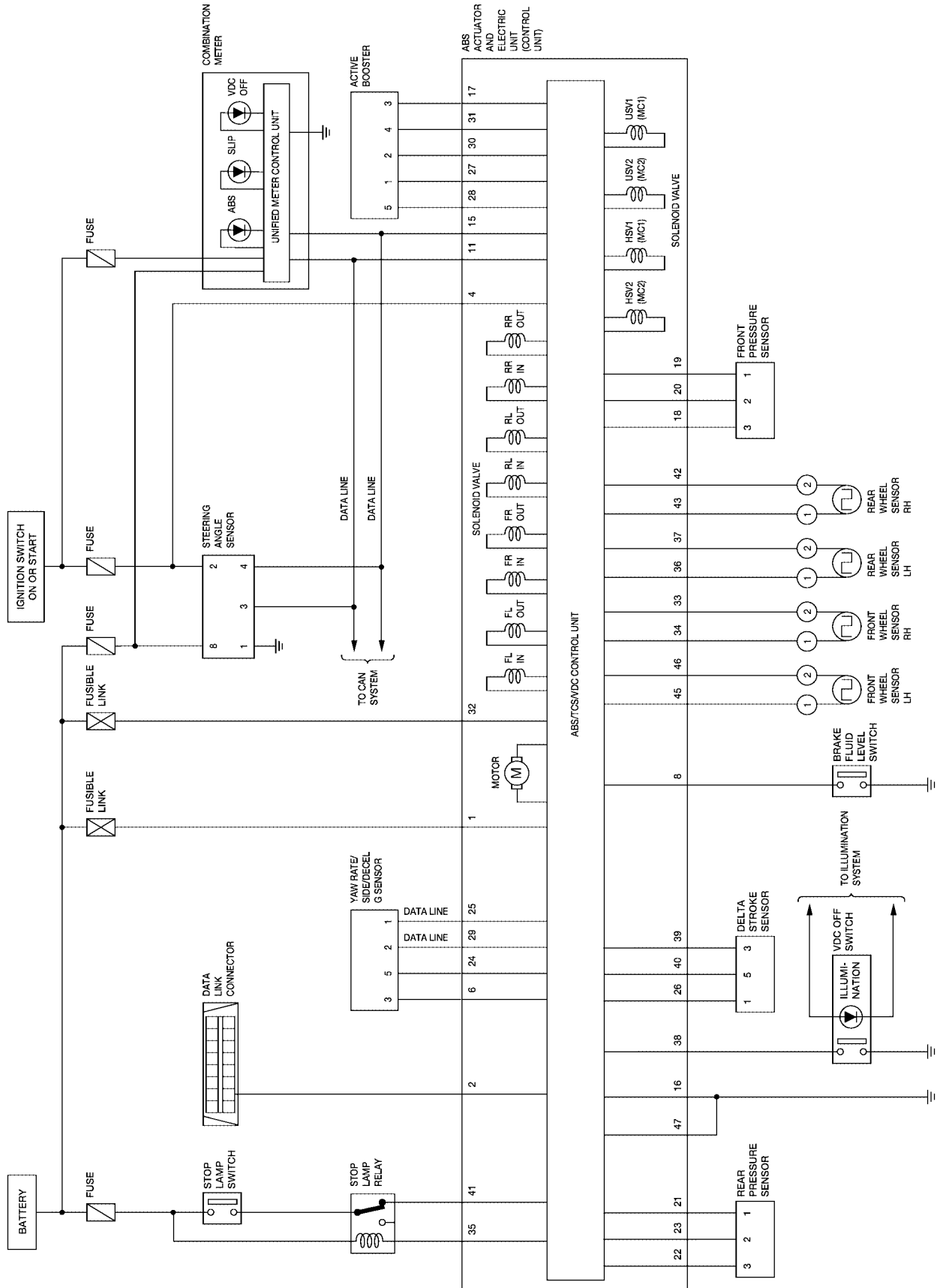

WFWA0208E

TROUBLE DIAGNOSIS

[VDC/TCS/ABS]

Wiring Diagram — VDC —

EFS004S2

BRC-VDC-01

CS : COLUMN SHIFT
FS : FLOOR SHIFT

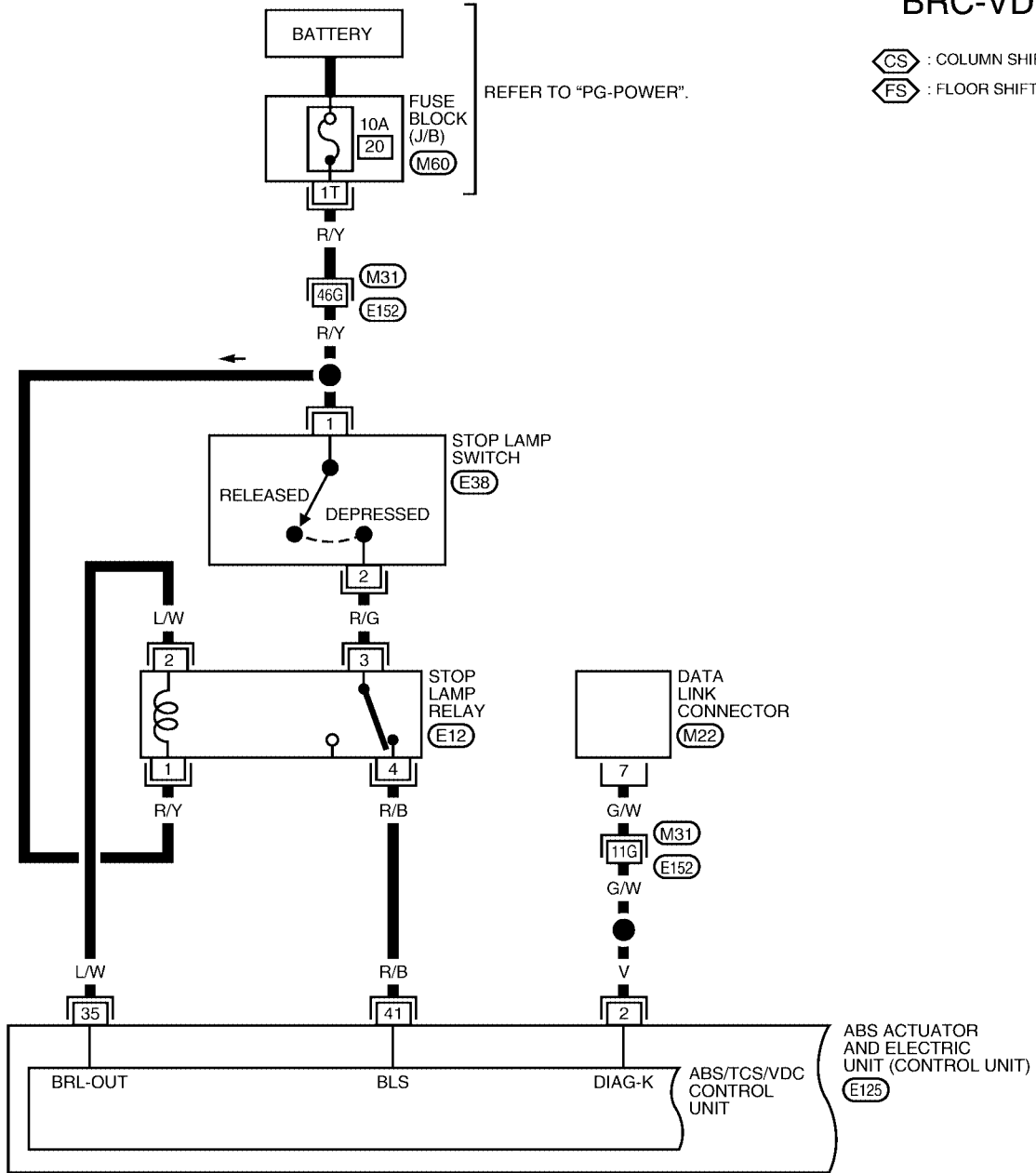

A
B
C
D
E
BRC
G
H
I
J
K
L
M

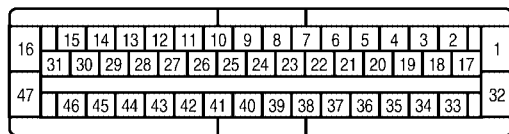
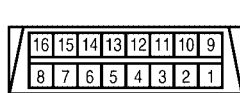

REFER TO THE FOLLOWING.
(M31) - SUPER MULTIPLE JUNCTION (SMJ)

WFWA0209E

TROUBLE DIAGNOSIS

[VDC/TCS/ABS]

BRC-VDC-02

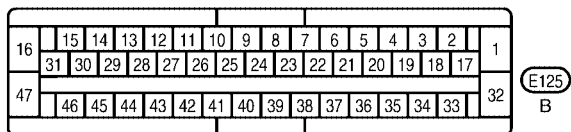
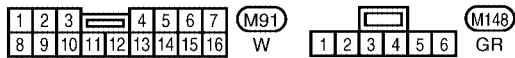
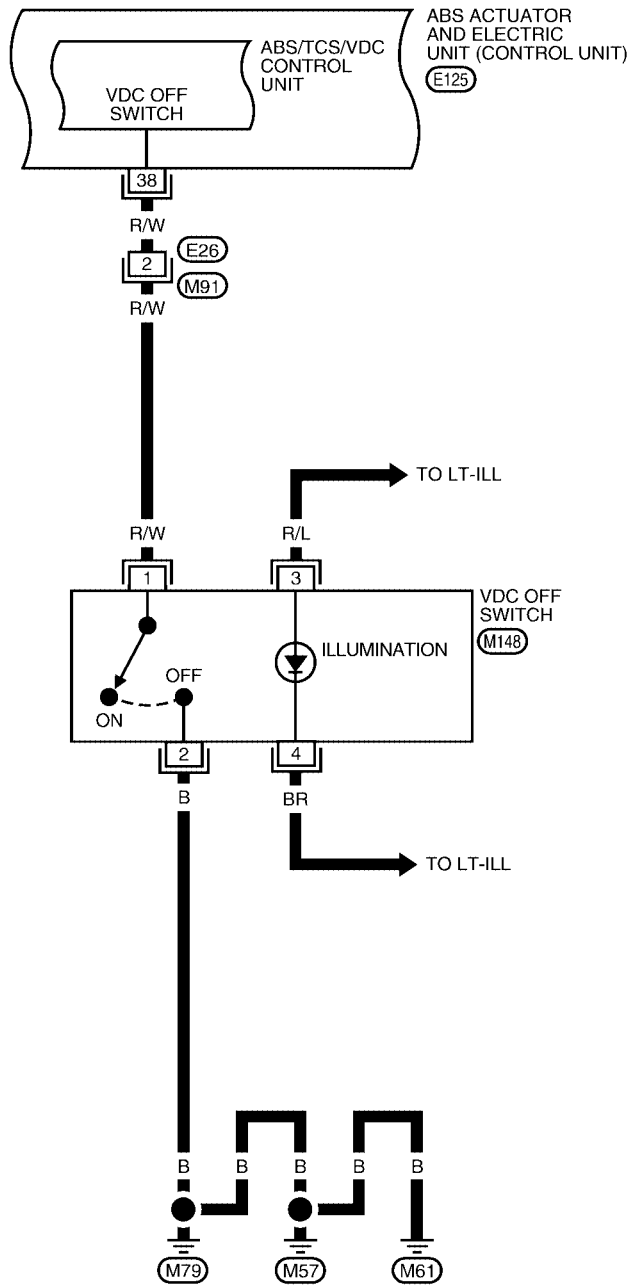

WFWA0210E

TROUBLE DIAGNOSIS

[VDC/TCS/ABS]

BRC-VDC-03

A
B
C
D
E
BRC
G
H
I
J
K
L
M

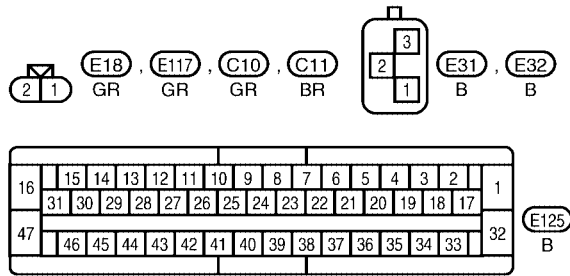
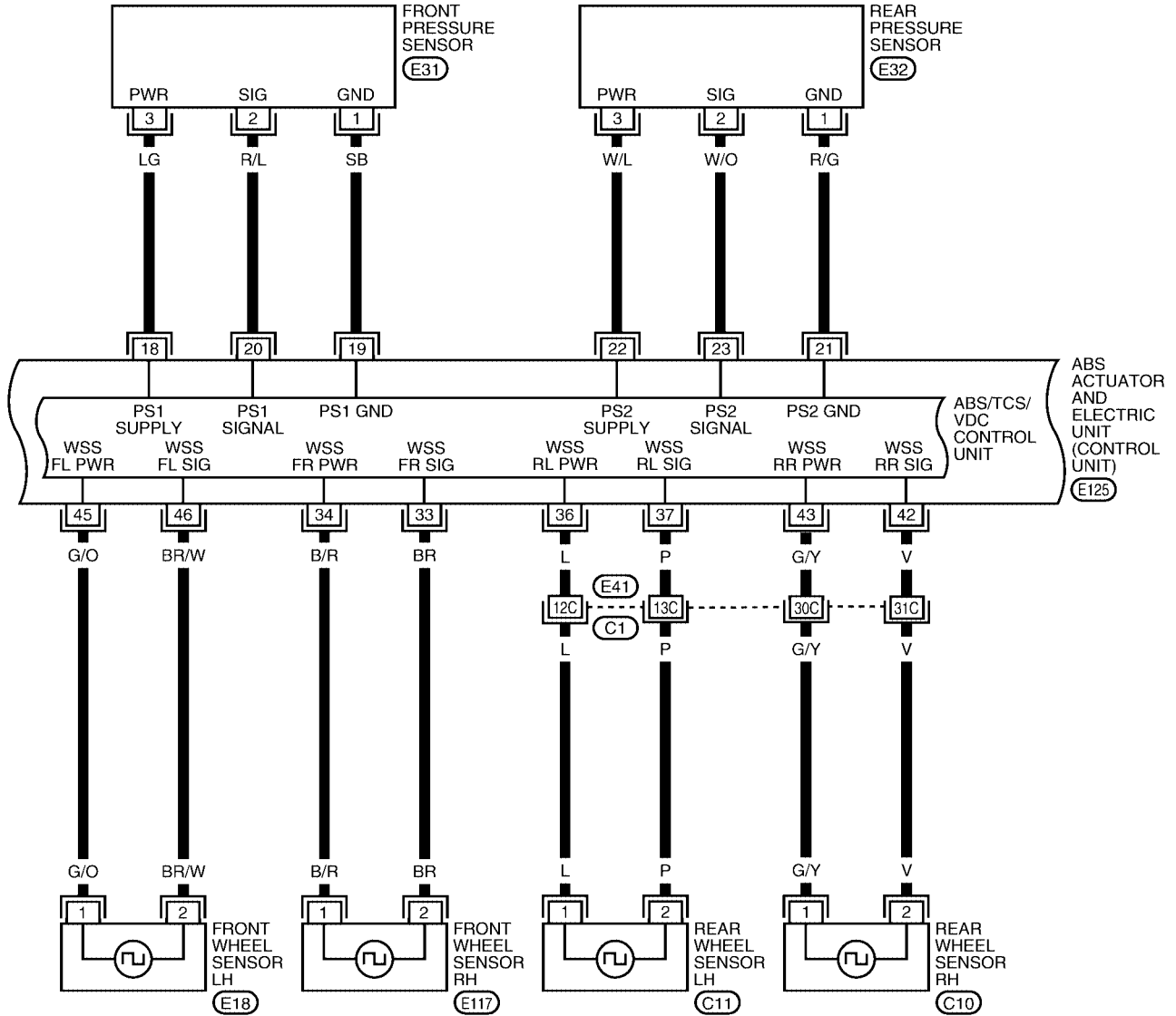

REFER TO THE FOLLOWING.
(C1) - SUPER MULTIPLE JUNCTION (SMJ)

WFWA0211E

TROUBLE DIAGNOSIS

[VDC/TCS/ABS]

BRC-VDC-04

▬ : DATA LINE

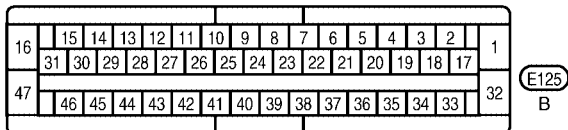
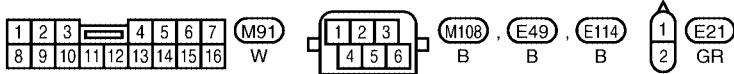
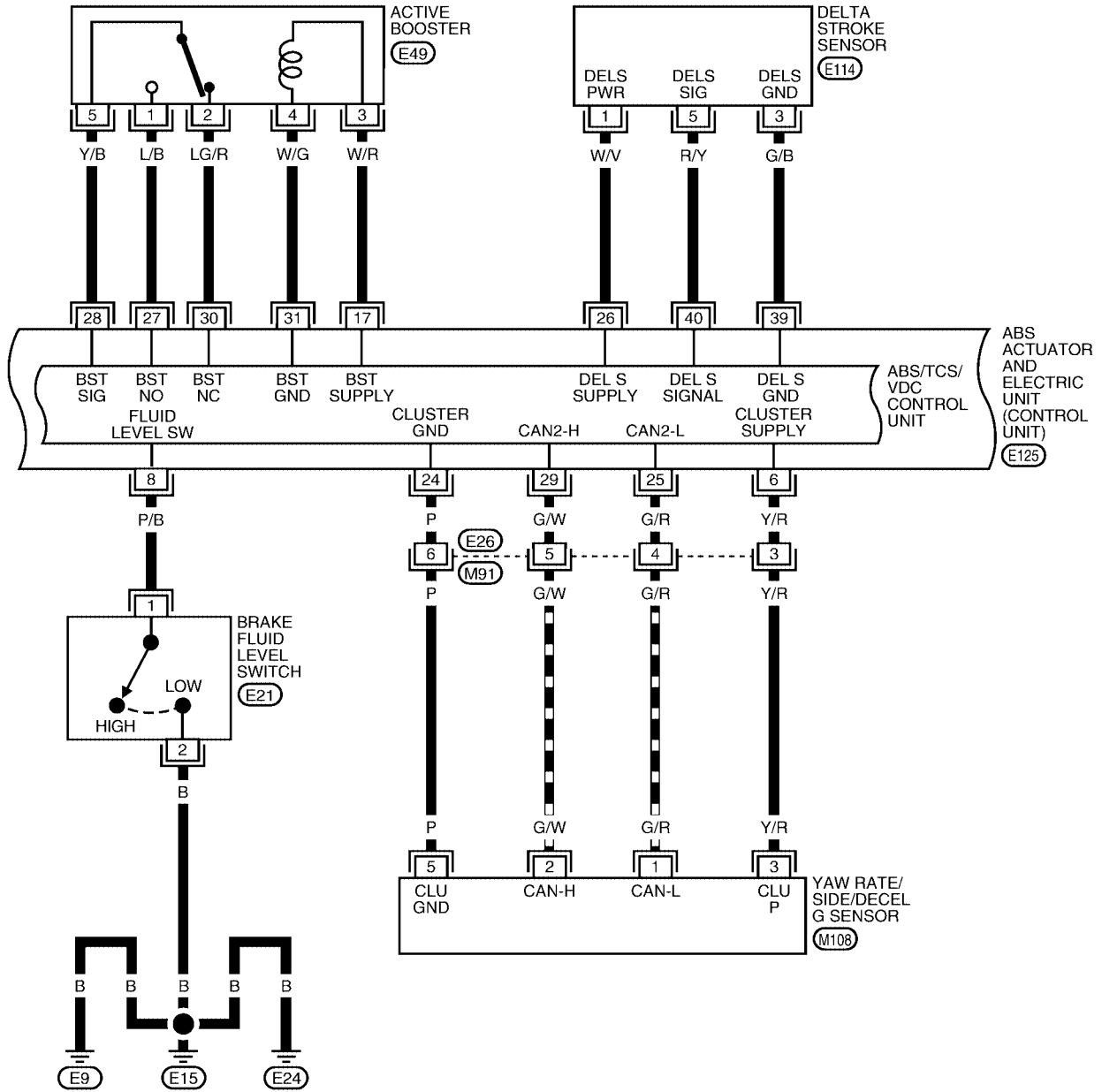

WFWA0212E

TROUBLE DIAGNOSIS

[VDC/TCS/ABS]

BRC-VDC-05

A
B
C
D
E
BRC
G
H
I
J
K
L
M

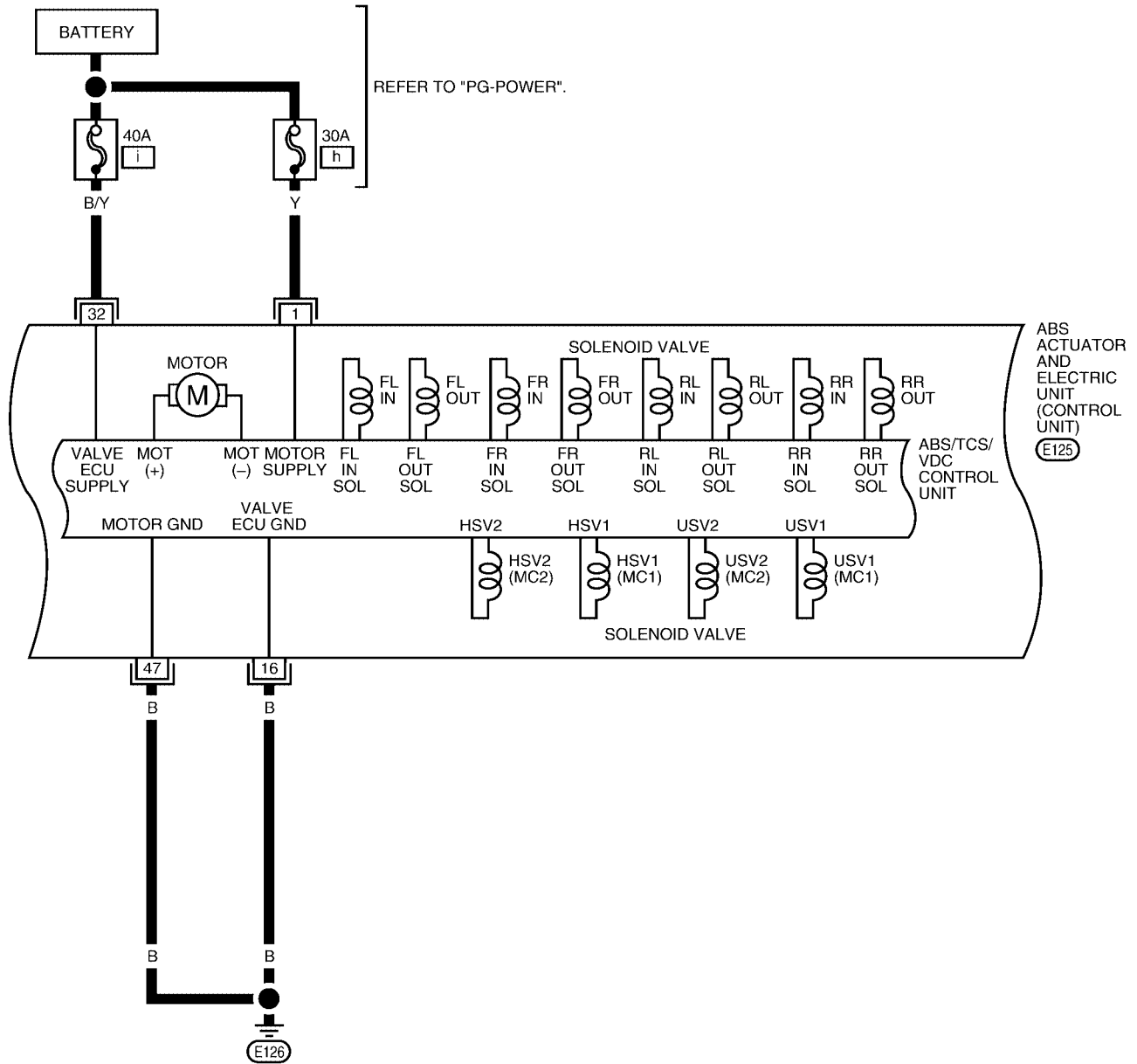

16	15	14	13	12	11	10	9	8	7	6	5	4	3	2	1
31	30	29	28	27	26	25	24	23	22	21	20	19	18	17	
47	46	45	44	43	42	41	40	39	38	37	36	35	34	33	32

(E125)
B

WFWA0213E

TROUBLE DIAGNOSIS

[VDC/TCS/ABS]

BRC-VDC-06

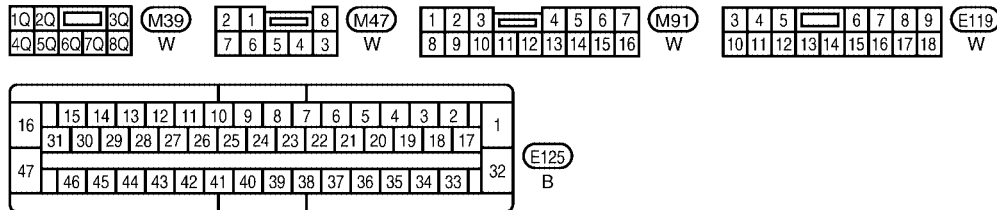
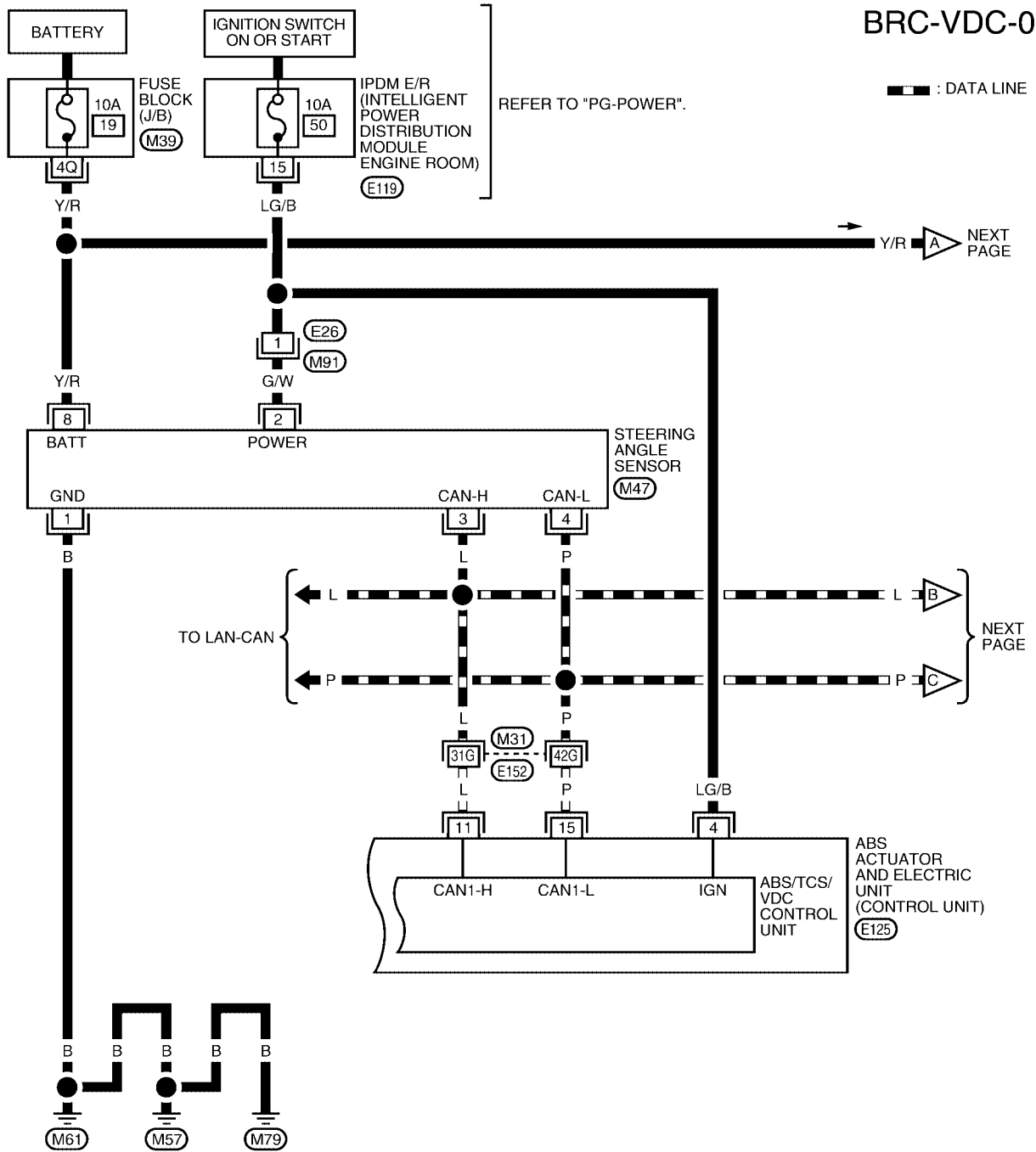

REFER TO THE FOLLOWING.
 (M31) - SUPER MULTIPLE JUNCTION (SMJ)

WFVA0214E

TROUBLE DIAGNOSIS

[VDC/TCS/ABS]

BRC-VDC-07

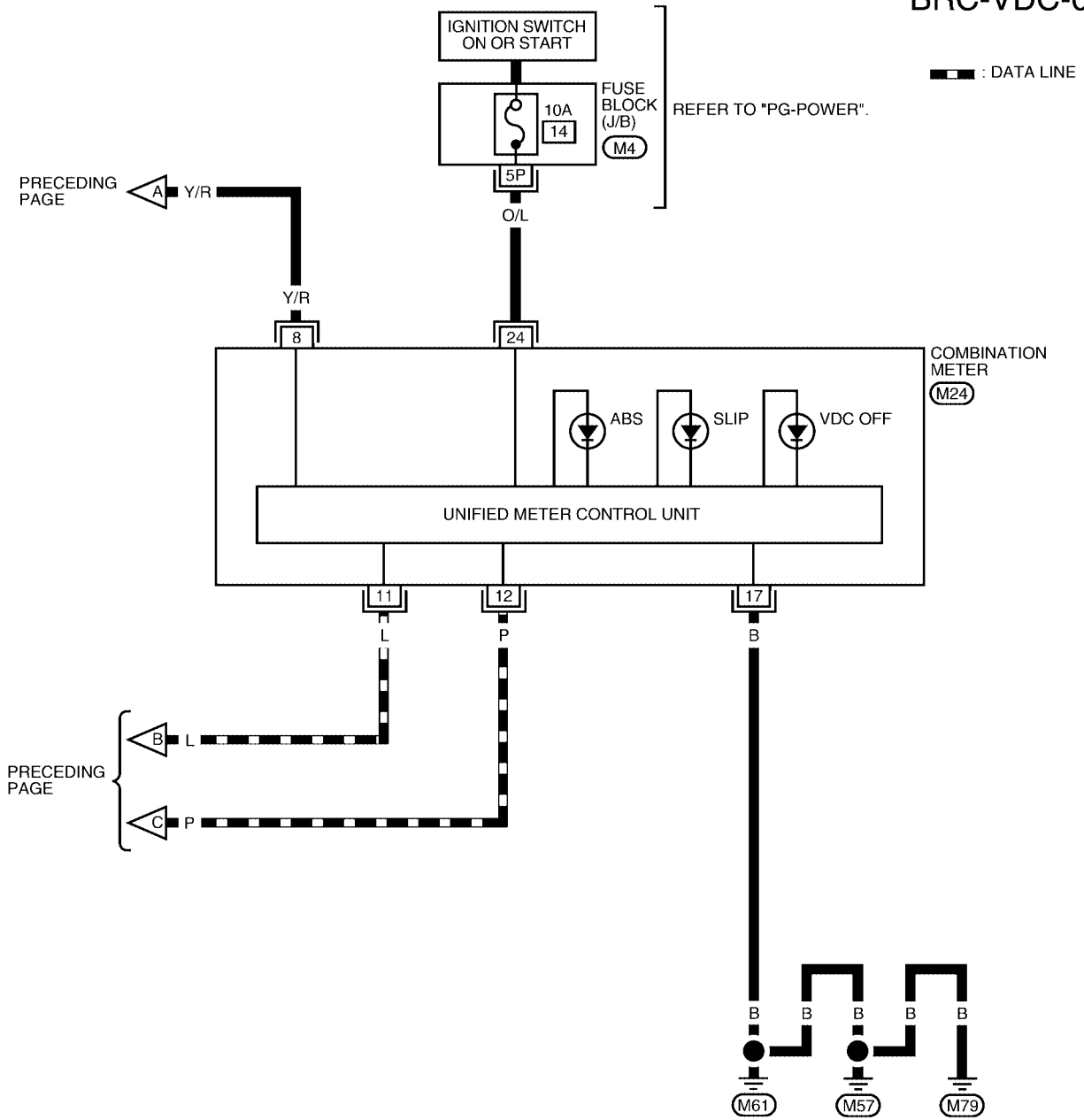

A
B
C
D
E
BRC
G
H
I
J
K
L
M

1P	2P	3P	4P	5P	6P	7P		
8P	9P	10P	11P	12P	13P	14P	15P	16P

(M4)
W

1	2	3	4	5	6	7	8	9	10	11	12	13	14	15	16	17	18	19	20
21	22	23	24	25	26	27	28	29	30	31	32	33	34	35	36	37	38	39	40

(M24)
W

WFWA0215E

Basic Inspection**BRAKE FLUID LEVEL, FLUID LEAK, AND BRAKE PAD INSPECTION**

1. Check fluid level in the brake fluid reservoir. If fluid level is low, add fluid.
2. Check the brake piping and around the ABS actuator and electric unit (control unit) for leaks. If there is leaking or seeping fluid, check the following items.
 - If ABS actuator and electric unit (control unit) connection is loose, tighten the piping to the specified torque and recheck for leaks.
 - If there is damage to the connection flare nut or ABS actuator and electric unit (control unit) threads, replace the damaged part and recheck for leaks.
 - When there is fluid leaking or seeping from a fluid connection, use a clean cloth to wipe off the fluid and recheck for leaks. If fluid is still seeping out, replace the damaged part. If the fluid is leaking at the ABS actuator and electric unit (control unit), replace the ABS actuator and electric unit (control unit) assembly.

CAUTION:

The ABS actuator and electric unit (control unit) cannot be disassembled and must be replaced as an assembly.

3. Check the brake pads for excessive wear.

POWER SYSTEM TERMINAL LOOSENESS AND BATTERY INSPECTION

Make sure the battery positive cable, negative cable and ground connection are not loose. In addition, make sure the battery is sufficiently charged.

ABS WARNING LAMP, SLIP INDICATOR LAMP AND VDC OFF INDICATOR LAMP INSPECTION

1. Make sure ABS warning lamp, SLIP indicator lamp and VDC OFF indicator lamp (when VDC OFF switch is off), turn on for approximately 1 second when the ignition switch is turned ON. If they do not, check the VDC OFF indicator lamp and the VDC OFF switch. Refer to [BRC-142, "VDC OFF SWITCH"](#) . Check CAN communications. If there are no errors with the VDC OFF switch or CAN communication system, check combination meter. Refer to [DI-5, "COMBINATION METERS"](#) .
2. Make sure the lamps turn off approximately 1 second after the ignition switch is turned ON. If the lamp does not turn off, conduct self-diagnosis.
3. With the engine running, make sure the VDC OFF indicator lamp turns on and off when the VDC OFF switch is turned on and off. If the indicator lamp status does not correspond to switch operation, check the VDC OFF switch. Refer to [BRC-142, "VDC OFF SWITCH"](#) .
4. Make sure ABS warning lamp, SLIP indicator lamp and VDC OFF indicator lamp turn off approximately 2 seconds after the engine is started. If ABS warning lamp, SLIP indicator lamp or VDC OFF indicator lamp have not turned off 10 seconds after the engine has been started, conduct self-diagnosis of the ABS actuator and electric unit (control unit).
5. After conducting the self-diagnosis, be sure to erase the error memory. Refer to [BRC-115, "CONSULT-II Function \(ABS\)"](#) .

TROUBLE DIAGNOSIS

[VDC/TCS/ABS]

Warning Lamp and Indicator Timing

EFS004S4

Condition	ABS warning lamp	VDC OFF indicator lamp	SLIP indicator lamp	Remarks
When the ignition switch is OFF	—	—	—	—
After the ignition switch is turned ON for approx. 1 second	×	×	×	—
After the ignition switch is turned ON for approx. 2 seconds	—	—	—	Lamp goes off approx. 2 seconds after the engine is started.
When the VDC OFF switch is pressed (VDC function OFF)	—	×	—	—
ABS/TCS/VDC malfunction	×	×	×	When the ABS actuator and electric unit (control unit) is malfunctioning (power supply or ground malfunction).
	×	×	—	
When the VDC is malfunctioning	—	×	×	—

X: ON
—: OFF

Control Unit Input/Output Signal Standard REFERENCE VALUE FROM CONSULT-II

EFS004S5

CAUTION:

The display shows the control unit calculation data, so a normal value might be displayed even in the event the output circuit (harness) is open or short circuited.

Monitor item	Display content	Data monitor		Note: Error inspection checklist
		Condition	Reference value in normal operation	
N POSI SIG	PNP switch signal ON/OFF condition	A/T shift position = N position	ON	BRC-140. "CAN Communication System Inspection"
		A/T shift position = other than N positions	OFF	
P POSI SIG	PNP switch signal ON/OFF condition	A/T shift position P position	ON	BRC-140. "CAN Communication System Inspection"
		A/T shift position = other than P positions	OFF	
GEAR	A/T gear position	1st gear	1	—
		2nd gear	2	
		3rd gear	3	
		4th gear	4	
		5th gear	5	
FR RH SENSOR FR LH SENSOR RR RH SENSOR RR LH SENSOR	Wheel speed	Vehicle stopped	0 [km/h (MPH)]	BRC-125. "Wheel Sensor System Inspection"
		Vehicle running (Note 1)	Almost in accordance with speedometer display (within ±10%)	
ACCEL POS SIG	Open/close condition of throttle valve (linked with accelerator pedal).	Accelerator pedal not depressed (ignition switch is ON)	0%	BRC-140. "CAN Communication System Inspection"
		Depress accelerator pedal (ignition switch is ON)	0 to 100%	
ENGINE SPEED	With engine running	With engine stopped	0 rpm	BRC-126. "Engine System Inspection"
		Engine running	Almost in accordance with tachometer display	

TROUBLE DIAGNOSIS

[VDC/TCS/ABS]

Monitor item	Display content	Data monitor		Note: Error inspection checklist
		Condition	Reference value in normal operation	
STR ANGLE SIG	Steering angle detected by steering angle sensor	Straight-ahead	Approx. 0 deg	BRC-127. "Steering Angle Sensor System"
		Steering wheel turned	-756 to 756 deg	
YAW RATE SEN	Yaw rate detected by yaw rate sensor	Vehicle stopped	Approx. 0 d/s	BRC-128. "Yaw Rate/Side/Decel G Sensor System Inspection"
		Vehicle running	-100 to 100 d/s	
SIDE G SENSOR	Transverse G detected by side G-sensor	Vehicle stopped	Approx. 0 m/s ²	BRC-128. "Yaw Rate/Side/Decel G Sensor System Inspection"
		Vehicle running	-16.7 to 16.7 m/s ²	
BATTERY VOLT	Battery voltage supplied to ABS actuator and electric unit (control unit)	Ignition switch ON	10 to 16V	BRC-133. "ABS/TCS/VDC Control Unit Power and Ground Systems Inspection"
STOP LAMP SW	Stop lamp switch operation	Brake pedal depressed	ON	BRC-132. "Stop Lamp Switch System Inspection"
		Brake pedal not depressed	OFF	
OFF SW	VDC OFF switch ON/OFF status	VDC OFF switch ON (When VDC OFF indicator lamp is ON)	ON	BRC-142. "VDC OFF SWITCH"
		VDC OFF switch OFF (When VDC OFF indicator lamp is OFF)	OFF	
ABS WARN LAMP	ABS warning lamp ON condition (Note 2)	ABS warning lamp ON	ON	—
		ABS warning lamp OFF	OFF	
MOTOR RELAY	Operation status of motor and motor relay	Ignition switch ON or running (ABS not activated)	OFF	BRC-131. "Actuator Motor, Motor Relay, and Circuit Inspection"
		Ignition switch ON or engine running (ABS activated)	ON	
ACTUATOR RLY	Actuator relay operation status	Vehicle stopped (Ignition switch ON)	OFF	BRC-131. "Actuator Motor, Motor Relay, and Circuit Inspection"
		Vehicle stopped (Engine running)	ON	
OFF LAMP	VDC OFF indicator lamp status (Note 3)	When VDC OFF indicator lamp is ON	ON	BRC-140. "CAN Communication System Inspection"
		When VDC OFF indicator lamp is OFF	OFF	
SLIP LAMP	SLIP indicator lamp status (Note 4)	When SLIP indicator lamp is ON	ON	BRC-140. "CAN Communication System Inspection"
		When SLIP indicator lamp is OFF	OFF	

TROUBLE DIAGNOSIS

[VDC/TCS/ABS]

Monitor item	Display content	Data monitor		Note: Error inspection checklist	
		Condition	Reference value in normal operation		
FR LH IN SOL FR LH OUT SOL FR RH IN SOL FR RH OUT SOL RR RH IN SOL RR RH OUT SOL RR LH IN SOL RR LH OUT SOL	Solenoid valve operation	Actuator (solenoid) is active ("ACTIVE TEST" with CONSULT-II) or actuator relay is inactive (in fail-safe mode).	ON		A
		When actuator (solenoid) is not active and actuator relay is active (ignition switch ON).	OFF		
CV1 CV2 SV1 SV2	VDC switch-over valve status	When actuator (switch-over valve) is active ("ACTIVE TEST" with CONSULT-II) or actuator relay is inactive (when in fail-safe mode).	ON	BRC-130, "Solenoid and VDC Change-Over Valve System Inspection"	C
		When actuator (switch-over valve) is not active and actuator relay is active (ignition switch ON).	OFF		
DECEL G-SEN	Longitudinal acceleration detected by Decel G-Sensor	Vehicle stopped	Approx. 0 G	BRC-128, "Yaw Rate/Side/Decel G Sensor System Inspection"	E
		Vehicle running	-1.7 to 1.7 G		
PRESS SENSOR	Brake fluid pressure detected by pressure sensor	Do not step on the Brake pedal (When ignition switch is ON)	Approx. 0 bar	—	H
		Step on the Brake pedal (When ignition switch is ON)	-40 to 300 bar		
FLUID LEV SW	ON/OFF status of brake fluid level switch	When brake fluid level switch ON	ON	DI-30, "WARNING LAMPS"	J
		When brake fluid level switch OFF	OFF		
VDC SIGNAL TCS SIGNAL ABS SIGNAL EBD SIGNAL	Signal status	VDC active TCS active ABS active EBD active	ON	VDC system TCS system ABS system EBD system	L
		VDC not active TCS not active ABS not active EBD not active	OFF		
VDC FAIL SIG TCS FAIL SIG ABS FAIL SIG EBD FAIL SIG	Fail signal status	VDC fail TCS fail ABS fail EBD fail	ON	VDC system TCS system ABS system EBD system	
		VDC normal TCS normal ABS normal EBD normal	OFF		

Note 1: Confirm tire pressure is normal.

Note 2: ON/OFF timing of ABS warning lamp

ON: For approximately 1 second after ignition switch is turned ON, or when a malfunction is detected.

OFF: Approximately 1 second after ignition switch is turned ON (when system is in normal operation) and TCS/VDC function is not activated.

Note 3: ON/OFF timing of VDC OFF indicator lamp

ON: For approximately 1 second after ignition switch is turned ON, or when a malfunction is detected and VDC OFF switch is ON.

OFF: Approximately 1 second after ignition switch is turned ON (when system is in normal operation.) And when VDC OFF switch is OFF.

Note 4: SLIP indicator lamp ON/OFF timing

ON: For approximately 1 second after ignition switch is turned ON, or when a malfunction is detected and TCS/VDC function is activated while driving.

TROUBLE DIAGNOSIS

[VDC/TCS/ABS]

OFF: Approximately 1 second after ignition switch is turned ON (when system is in normal operation) and TCS/VDC function is not activated.

Flashing: TCS/VDC function is active during driving

CONSULT-II Function (ABS)

CONSULT-II can display each diagnostic item using the diagnostic test modes shown following.

ABS diagnostic mode	Description
WORK SUPPORT	Supports inspection and adjustments. Commands are transmitted to the ABS actuator and electric unit (control unit) for setting the status suitable for required operation, input/output signals are received from the ABS actuator and electric unit (control unit) and received data is displayed.
SELF-DIAG RESULTS	Displays ABS actuator and electric unit (control unit) self-diagnosis results.
DATA MONITOR	Displays ABS actuator and electric unit (control unit) input/output data in real time.
CAN DIAG SUPPORT MNTR	The result of transmit/receive diagnosis of CAN communication can be read.
ACTIVE TEST	Operation of electrical loads can be checked by sending drive signal to them.
FUNCTION TEST	Conducted by CONSULT-II instead of a technician to determine whether each system is "OK" or "NG".
ECU PART NUMBER	ABS actuator and electric unit (control unit) part number can be read.

CONSULT-II BASIC OPERATION PROCEDURE

1. Turn ignition switch OFF.
2. Connect CONSULT-II and CONSULT-II CONVERTER to the data link connector.

CAUTION:

If CONSULT-II is used with no connection of CONSULT-II CONVERTER, malfunctions might be detected in self-diagnosis depending on control unit which carries out CAN communication.

3. Turn ignition switch ON.

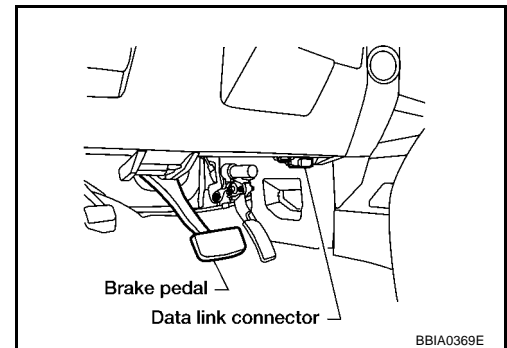

4. Touch "START (NISSAN BASED VHCL)".

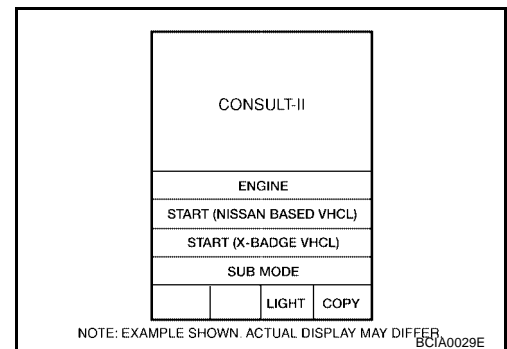

5. Touch "ABS" in the "SELECT SYSTEM" screen. If "ABS" is not indicated, go to [GI-38, "CONSULT-II Data Link Connector \(DLC\) Circuit"](#).

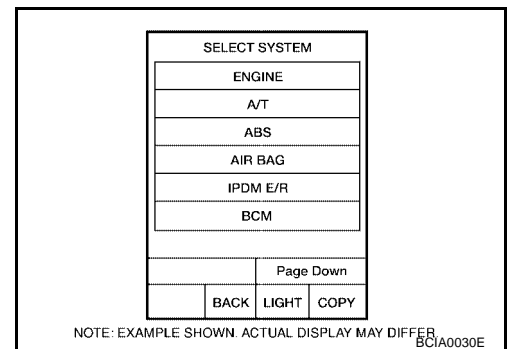

6. Select the required diagnostic location from the “SELECT DIAG MODE” screen.
For further information, see the CONSULT-II Operation Manual.

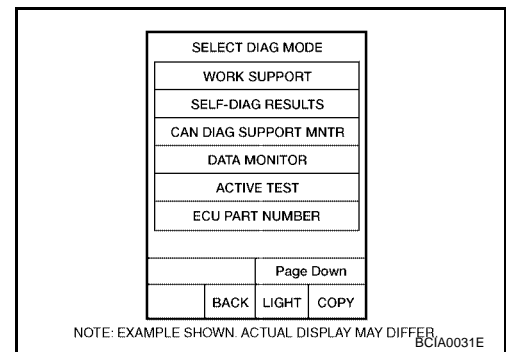

SELF-DIAGNOSIS

Description

If an error is detected in the system, the ABS warning lamp will turn on. In this case, perform self-diagnosis as follows:

Operation Procedure

1. Turn ignition switch OFF.
2. Connect CONSULT-II and CONSULT-II CONVERTER to the data link connector.

CAUTION:

If **CONSULT-II** is used with no connection of **CONSULT-II CONVERTER**, malfunctions might be detected in self-diagnosis depending on control unit which carries out **CAN** communication.

3. Turn ignition switch ON.
4. Start engine and drive at approximately 30 km/h (19 MPH) or more for approximately 1 minute.
5. After stopping the vehicle, with the engine running, touch “START (NISSAN BASED VHCL)”, “ABS”, “SELF-DIAG RESULTS” in order on the CONSULT-II screen.

CAUTION:

If “**START (NISSAN BASED VHCL)**” is touched immediately after starting the engine or turning on the ignition switch, “**ABS**” might not be displayed in the System Selection screen. In this case, repeat the operation from step 1.

6. The self-diagnostic results are displayed. (If necessary, the self-diagnostic results can be printed out by touching “PRINT”.)
 - When “NO DTC IS DETECTED” is displayed, check the ABS warning lamp, SLIP indicator lamp and VDC OFF indicator lamp.
7. Conduct the appropriate inspection from the display item list, and repair or replace the malfunctioning component.
8. Start engine and drive at approximately 30 km/h (19 MPH) or more for approximately 1 minute.

CAUTION:

● When a wheel sensor “short-circuit” is detected, if the vehicle is not driven at 30 km/h (19 MPH) for at least 1 minute, the ABS warning lamp will not turn off even if the malfunction is repaired.

9. Turn ignition switch OFF to prepare for erasing the memory.
10. Start the engine and touch “START (NISSAN BASED VHCL)”, “ABS”, “SELF-DIAG RESULTS”, “ERASE” in order on the CONSULT-II screen to erase the error memory.
If “ABS” is not indicated, go to [GI-38, "CONSULT-II Data Link Connector \(DLC\) Circuit"](#).

CAUTION:

If the error memory is not erased, re-conduct the operation from step 5.

11. For the final inspection, drive at approximately 30 km/h (19 MPH) or more for approximately 1 minute and confirm that the ABS warning lamp, SLIP indicator lamp, and VDC OFF indicator lamp are off.

TROUBLE DIAGNOSIS

[VDC/TCS/ABS]

Display Item List

Self-diagnostic item	Malfunction detecting condition	Check system	
FR LH SENSOR 1 [C1104]	Circuit of front LH wheel sensor is open, shorted or sensor power voltage is unusual.	BRC-125. " Wheel Sensor System Inspection " (Note 1)	
RR RH SENSOR 1 [C1101]	Circuit of rear RH wheel sensor is open, shorted or sensor power voltage is unusual.		
FR RH SENSOR 1 [C1103]	Circuit of front RH wheel sensor is open, shorted or sensor power voltage is unusual.		
RR LH SENSOR 1 [C1102]	Circuit of rear LH wheel sensor is open, shorted or sensor power voltage is unusual.		
FR LH SENSOR 2 [C1108]	ABS actuator and electric unit (control unit) cannot identify sensor pulses, because of large gap between wheel sensor and sensor rotor.		
RR RH SENSOR 2 [C1105]	ABS actuator and electric unit (control unit) cannot identify sensor pulses, because of large gap between wheel sensor and sensor rotor.		
FR RH SENSOR 2 [C1107]	ABS actuator and electric unit (control unit) cannot identify sensor pulses, because of large gap between wheel sensor and sensor rotor.		
RR LH SENSOR 2 [C1106]	ABS actuator and electric unit (control unit) cannot identify sensor pulses, because of large gap between wheel sensor and sensor rotor.		
STOP LAMP SW [C1116]	Stop lamp switch or circuit malfunction.		BRC-132. " Stop Lamp Switch System Inspection "
DECEL G SEN SET [C1160]	ABS decel sensor adjustment is incomplete.		BRC-141. " Inspection For Self-diagnosis Result "DECEL G SEN SET" "
ST ANGLE SEN CIRCUIT [C1143]	Neutral position of steering angle sensor is dislocated, or steering angle sensor is malfunctioning.	BRC-127. " Steering Angle Sensor System "	
YAW RATE SENSOR [C1145]	Yaw rate sensor has generated an error, or yaw rate sensor signal line is open or shorted.	BRC-128. " Yaw Rate/Side/Decel G Sensor System Inspection "	

A

B

C

D

E

BRC

G

H

I

J

K

L

M

TROUBLE DIAGNOSIS

[VDC/TCS/ABS]

Self-diagnostic item	Malfunction detecting condition	Check system	
FR LH IN ABS SOL [C1120]	Circuit of front LH IN ABS solenoid is open or shorted, or control line is open or shorted to power supply or ground.	BRC-130. "Solenoid and VDC Change-Over Valve System Inspection"	
FR LH OUT ABS SOL [C1121]	Circuit of front LH OUT ABS solenoid is open or shorted, or control line is open or shorted to power supply or ground.		
RR RH IN ABS SOL [C1126]	Circuit of rear RH IN ABS solenoid is open or shorted, or control line is open or shorted to power supply or ground.		
RR RH OUT ABS SOL [C1127]	Circuit of rear RH OUT ABS solenoid is open or shorted, or control line is open or shorted to power supply or ground.		
FR RH IN ABS SOL [C1122]	Circuit of front RH IN ABS solenoid is open or shorted, or control line is open or shorted to power supply or ground.		
FR RH OUT ABS SOL [C1123]	Circuit of front RH OUT ABS solenoid is open or shorted, or control line is open or shorted to power supply or ground.		
RR LH IN ABS SOL [C1124]	Circuit of rear LH IN ABS solenoid is open or shorted, or control line is open or shorted to power supply or ground.		
RR LH OUT ABS SOL [C1125]	Circuit of rear LH OUT ABS solenoid is open or shorted, or control line is open or shorted to power supply or ground.		
CV1 [C1164]	Front side VDC switch-over solenoid valve (cut valve) is open or shorted, or control line is open or shorted to power supply or ground.		
CV2 [C1165]	Rear side VDC switch-over solenoid valve (cut valve) is open or shorted, or control line is open or shorted to power supply or ground.		
SV1 [C1166]	Front side VDC switch-over solenoid valve (suction valve) is open or shorted, or control line is open or shorted to power supply or ground.		
SV2 [C1167]	Rear side VDC switch-over solenoid valve (suction valve) is open or shorted, or control line is open or shorted to power supply or ground.		
PUMP MOTOR (Note 3) [C1111]	During actuator motor operation with ON, when actuator motor turns OFF or when control line for actuator motor relay is open.		BRC-131. "Actuator Motor, Motor Relay, and Circuit Inspection"
	During actuator motor operation with OFF, when actuator motor turns ON or when control line for relay is shorted to ground.		
BATTERY VOLTAGE [ABNORMAL] [C1109]	ABS actuator and electric unit (control unit) power voltage is too low.	BRC-133. "ABS/TCS/VDC Control Unit Power and Ground Systems Inspection"	
ST ANGLE SEN SIGNAL [C1144]	Neutral position correction of steering angle sensor is not finished.	BRC-141. "Inspection For Self-diagnosis Result "ST ANGLE SEN SIGNAL""	
ST ANG SEN COM CIR [C1156]	CAN communication line or steering angle sensor has generated an error.	BRC-127. "Steering Angle Sensor System"	
G-SENSOR [C1113]	G-sensor is malfunctioning, or signal line of G-sensor is open or shorted.	BRC-128. "Yaw Rate/Side/Decel G Sensor System Inspection"	
CONTROLLER FAILURE [C1110]	Internal malfunction of ABS actuator and electric unit (control unit)	BRC-127. "ABS/TCS/VDC Control Unit Inspection"	
CAN COMM CIRCUIT [U1000]	<ul style="list-style-type: none"> ● CAN communication line is open or shorted. ● ABS actuator and electric unit (control unit) internal malfunction ● Battery voltage for ECM is suddenly interrupted for approximately 0.5 second or more. 	BRC-140. "CAN Communication System Inspection" (Note 2)	

TROUBLE DIAGNOSIS

[VDC/TCS/ABS]

Self-diagnostic item	Malfunction detecting condition	Check system	
SIDE G-SEN CIRCUIT [C1146]	Side G-sensor is malfunctioning, or signal line of side G-sensor is open or shorted.	BRC-128, "Yaw Rate/Side/Decel G Sensor System Inspection"	
BR FLUID LEVEL LOW [C1155]	Brake fluid level drops or circuit between ABS actuator and electric unit (control unit) and brake fluid level switch is open or shorted.	BRC-134, "Brake Fluid Level Sensor System Inspection"	
ENGIN SIGNAL 1 [C1130]	Based on the signal from ECM, ABS actuator and electric unit (control unit) judges that engine fuel cut system is malfunctioning.		
ENGIN SIGNAL 2 [C1131]	Based on the signal from ECM, ABS actuator and electric unit (control unit) judges that engine fuel cut system is malfunctioning.		
ENGIN SIGNAL 3 [C1132]	Based on the signal from ECM, ABS actuator and electric unit (control unit) judges that engine fuel cut system is malfunctioning.		BRC-126, "Engine System Inspection"
ENGIN SIGNAL 4 [C1133]	Based on the signal from ECM, ABS actuator and electric unit (control unit) judges that engine fuel cut system is malfunctioning.		
ENGIN SIGNAL 6 [C1136]	Based on the signal from ECM, ABS actuator and electric unit (control unit) judges that engine fuel cut system is malfunctioning.		
ACTUATOR RLY [C1140]	ABS actuator relay or circuit malfunction.		BRC-131, "Actuator Motor, Motor Relay, and Circuit Inspection"
PRESS SEN CIRCUIT [C1142]	ABS pressure sensor circuit malfunction.	BRC-138, "Pressure Sensor System Inspection"	
VARIANT CODING [C1170]	V coding is not malfunctioning.	BRC-127, "ABS/TCS/VDC Control Unit Inspection"	
ABS ACTIVEBOOSTER SV NG [C1178]	Active booster solenoid is malfunctioning, or signal line of active booster servo is open or shorted.	BRC-135, "Active Booster System Inspection"	
DELTA S SEN NG [C1179]	Delta stroke sensor malfunctioning, or signal line of delta stroke sensor is open or shorted.	BRC-136, "Delta Stroke Sensor System Inspection"	
ABS ACTIVEBOOSTER RESPONSE NG [C1181]	Active booster response is malfunctioning, or signal line of active booster response is open or shorted.	BRC-135, "Active Booster System Inspection"	
ABS BRAKE RELEASE SW NG [C1184]	Brake release switch is malfunctioning, or signal line of brake release switch is open or shorted.		
ABS BRAKEBOOSTER DEFECT [C1189]	Brake booster is defective or malfunctioning.		

A
B
C
D
E
BRC
G
H
I
J
K
L
M

Note 1. If wheel sensor 2 for each wheel is indicated, check ABS actuator and electric unit (control unit) power supply voltage in addition to wheel sensor circuit check.

Note 2. If multiple malfunctions are detected including CAN communication line [U1000], perform diagnosis for CAN communication line first.

Note 3: "ACTUATOR RLY" on the CONSULT-II self-diagnosis results indicates the malfunction of the actuator motor relay or circuit.

DATA MONITOR

Operation Procedure

1. After turning OFF the ignition switch, connect CONSULT-II and the CONSULT-II CONVERTER to the data link connector.

TROUBLE DIAGNOSIS

[VDC/TCS/ABS]

CAUTION:

If CONSULT-II is used with no connection of CONSULT-II CONVERTER, malfunctions might be detected in self-diagnosis depending on control unit which carries out CAN communication.

2. Touch "START (NISSAN BASED VHCL)", "ABS", "DATA MONITOR" in order on the CONSULT-II screen. If "ABS" is not indicated, go to [GI-38, "CONSULT-II Data Link Connector \(DLC\) Circuit"](#).

CAUTION:

When "START (NISSAN BASED VHCL)" is touched immediately after starting the engine or turning on the ignition switch, "ABS" might not be displayed in the system selection screen. In this case, repeat the operation from step 2.

3. Return to the Monitor Item Selection screen, and touch "ECU INPUT SIGNALS", "MAIN SIGNALS", or "SELECTION FROM MENU". Refer to the following information.
4. When "START" is touched, the data monitor screen is displayed.

Display Item List

Item (Unit)	Data monitor item selection			Remarks
	ECU INPUT SIGNALS	MAIN SIGNALS	SELECTION FROM MENU	
GEAR	×	×	×	Gear position judged by PNP switch signal is displayed.
FR RH SENSOR (km/h, MPH)	×	×	×	Wheel speed calculated by front RH wheel sensor signal is displayed.
FR LH SENSOR (km/h, MPH)	×	×	×	Wheel speed calculated by front LH wheel sensor signal is displayed.
RR RH SENSOR (km/h, MPH)	×	×	×	Wheel speed calculated by rear RH wheel sensor signal is displayed.
RR LH SENSOR (km/h, MPH)	×	×	×	Wheel speed calculated by rear LH wheel sensor signal is displayed.
BATTERY VOLT (V)	×	×	×	Voltage supplied to ABS actuator and electric unit (control unit) is displayed.
N POSI SIG	—	—	×	Shift position judged by PNP switch signal.
P POSI SIG	—	—	×	Shift position judged by PNP switch signal.
ACCEL POS SIG (%)	×	—	×	Throttle valve open/close status judged by CAN communication signal is displayed.
ENGINE SPEED (rpm)	×	×	×	Engine speed judged by CAN communication signal is displayed.
STR ANGLE SIG (deg)	×	—	×	Steering angle detected by steering angle sensor is displayed.
YAW RATE SEN (d/s)	×	×	×	Yaw rate detected by yaw rate sensor is displayed.
DECEL G SEN (d/s)	×	×	×	Longitudinal acceleration detected by decel G-sensor is displayed.
SIDE G-SENSOR (m/s ²)	×	—	×	Transverse acceleration detected by side G-sensor is displayed.
STOP LAMP SW (ON/OFF)	×	×	×	Stop lamp switch (ON/OFF) status is displayed.
OFF SW (ON/OFF)	×	×	×	VDC OFF switch (ON/OFF) status is displayed.
ABS WARN LAMP (ON/OFF)	—	×	×	ABS warning lamp (ON/OFF) status is displayed.

TROUBLE DIAGNOSIS

[VDC/TCS/ABS]

Item (Unit)	Data monitor item selection			Remarks
	ECU INPUT SIGNALS	MAIN SIGNALS	SELECTION FROM MENU	
SLIP LAMP (ON/OFF)	-	×	×	SLIP indicator lamp (ON/OFF) status is displayed.
FR LH IN SOL (ON/OFF)	-	×	×	Front LH IN ABS solenoid (ON/OFF) status is displayed.
FR LH OUT SOL (ON/OFF)	-	×	×	Front LH OUT ABS solenoid (ON/OFF) status is displayed.
RR RH IN SOL (ON/OFF)	-	×	×	Rear RH IN ABS solenoid (ON/OFF) status is displayed.
RR RH OUT SOL (ON/OFF)	-	×	×	Rear RH OUT ABS solenoid (ON/OFF) status is displayed.
FR RH IN SOL (ON/OFF)	-	×	×	Front RH IN ABS solenoid (ON/OFF) status is displayed.
FR RH OUT SOL (ON/OFF)	-	×	×	Front RH OUT ABS solenoid (ON/OFF) status is displayed.
RR LH IN SOL (ON/OFF)	-	×	×	Rear LH IN ABS solenoid (ON/OFF) status is displayed.
RR LH OUT SOL (ON/OFF)	-	×	×	Rear LH OUT ABS solenoid (ON/OFF) status is displayed.
OFF LAMP (ON/OFF)	-	×	×	OFF Lamp (ON/OFF) status is displayed.
MOTOR RELAY (ON/OFF)	-	×	×	ABS motor relay signal (ON/OFF) status is displayed.
ACTUATOR RLY (ON/OFF)	-	×	×	ABS actuator relay signal (ON/OFF) status is displayed.
CV1 (ON/OFF)	-	-	×	Front side switch-over solenoid valve (cut valve) (ON/OFF) status is displayed.
CV2 (ON/OFF)	-	-	×	Rear side switch-over solenoid valve (cut-valve) (ON/OFF) status is displayed.
SV1 (ON/OFF)	-	-	×	Front side switch-over solenoid valve (suction valve) (ON/OFF) status is displayed.
SV2 (ON/OFF)	-	-	×	Rear side switch-over solenoid valve (suction valve) (ON/OFF) status is displayed.
VDC FAIL SIG (ON/OFF)	-	-	×	VDC fail signal (ON/OFF) status is displayed.
TCS FAIL SIG (ON/OFF)	-	-	×	TCS fail signal (ON/OFF) status is displayed.
ABS FAIL SIG (ON/OFF)	-	-	×	ABS fail signal (ON/OFF) status is displayed.
EBD FAIL SIG (ON/OFF)	-	-	×	EBD fail signal (ON/OFF) status is displayed.
FLUID LEV SW (ON/OFF)	×	-	×	Brake fluid level switch (ON/OFF) status is displayed.
EBD SIGNAL (ON/OFF)	-	-	×	EBD operation (ON/OFF) status is displayed.
ABS SIGNAL (ON/OFF)	-	-	×	ABS operation (ON/OFF) status is displayed.
TCS SIGNAL (ON/OFF)	-	-	×	TCS operation (ON/OFF) status is displayed.

A

B

C

D

E

BRC

G

H

I

J

K

L

M

TROUBLE DIAGNOSIS

[VDC/TCS/ABS]

Item (Unit)	Data monitor item selection			Remarks
	ECU INPUT SIGNALS	MAIN SIGNALS	SELECTION FROM MENU	
VDC SIGNAL (ON/OFF)	-	-	×	VDC operation (ON/OFF) status is displayed.
EBD WARN LAMP	-	-	×	Brake warning lamp (ON/OFF) status is displayed.
SLCT LVR POSI	×	×	×	Shift position judged by PNP switch signal.
R POSI SIG	-	-	×	Shift position judged by PNP switch signal.
4WD FAIL REQ	-	-	×	The state of 4WD controller is displayed by CAN communication signal.
2WD/4WD	-	-	×	It recognizes on software whether it is 2WD and whether it is in 4WD state.
BST OPER SIG	-	-	×	Active booster operation (ON/OFF) status is displayed.
PRESS SENSOR	×	-	×	Brake pressure detected by pressure sensor is displayed.
CRANKING SIG	-	-	×	The input state of the key SW START position signal is displayed.
PRESS SEN 2	-	-	×	Brake pressure detected by pressure sensor is displayed.
DELTA S SEN	-	-	×	The amount of stroke sensor movements in the active booster detected by DELTA S SEN is displayed.
RELEASE SW NO	-	-	×	Release switch signal (ON/OFF) status is displayed. "ON" indicates that the brake pedal is depressed. "OFF" is that the brake pedal is released.
RELEASE SW NC	-	-	×	Release switch signal (ON/OFF) status is displayed. "OFF" indicates that the brake pedal is depressed on. "ON" is that the brake pedal is released.
OHB FAIL	-	-	×	OHB fail status is displayed.
HBA FAIL	-	-	×	HBA fail status is displayed.
OHB SIG	-	-	×	OHB operation (ON/OFF) status is displayed.
HBA SIG	-	-	×	HBA operation (ON/OFF) status is displayed.
PRES CTRL ACC	-	-	×	Pressure control state (ON/OFF) is displayed. It is applied only to an ICC vehicle.
PRES FAIL ACC	-	-	×	Pressure control fail state (ON/OFF) is displayed. It is applied only to an ICC vehicle.
STP OFF RLY	-	-	×	Stop lamp relay signal (ON/OFF) status is displayed.

×: Applicable

-: Not applicable

ACTIVE TEST

CAUTION:

- Do not perform active test while driving.
- Make sure to completely bleed air from the brake system.
- The ABS and brake (EBD) warning lamps turn on during the active test.

Operation Procedure

1. Connect the CONSULT-II and CONSULT-II CONVERTER to the data link connector and start the engine.

CAUTION:

If CONSULT-II is used with no connection of CONSULT-II CONVERTER, malfunctions might be detected in self-diagnosis depending on control unit which carries out CAN communication.

2. Touch "START (NISSAN BASED VHCL)" on the display screen.
3. Touch "ABS".
If "ABS" is not indicated, go to [GI-38, "CONSULT-II Data Link Connector \(DLC\) Circuit"](#).
4. Touch "ACTIVE TEST".
5. The test item selection screen is displayed.
6. Touch necessary test item.

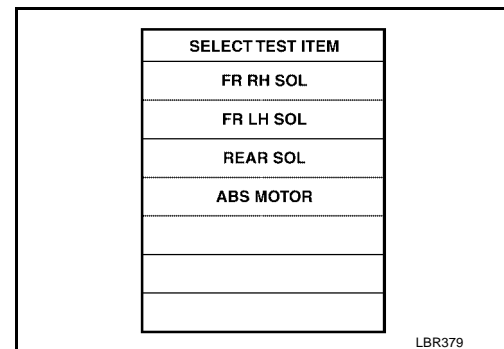

7. With the "MAIN SIGNALS" display selected, touch "START".
8. The Active Test screen will be displayed, so conduct the following test.

Solenoid Valve Operation Chart

Operation		ABS solenoid valve			ABS solenoid valve (ACT)		
		UP	KEEP	DOWN	UP	ACTUA-TOR UP	ACTUA-TOR KEEP
FR RH SOL FR RH ABS SOLE- NOID (ACT)	FR RH IN SOL	OFF	ON	ON	OFF	OFF	OFF
	FR RH OUT SOL	OFF	OFF	ON*	OFF	OFF	OFF
FR LH SOL FR LH ABS SOLE- NOID (ACT)	FR LH IN SOL	OFF	ON	ON	OFF	OFF	OFF
	FR LH OUT SOL	OFF	OFF	ON*	OFF	OFF	OFF
RR RH SOL RR RH ABS SOLE- NOID (ACT)	RR RH IN SOL	OFF	ON	ON	OFF	OFF	OFF
	RR RH OUT SOL	OFF	OFF	ON*	OFF	OFF	OFF
RR LH SOL RR LH ABS SOLE- NOID (ACT)	RR LH IN SOL	OFF	ON	ON	OFF	OFF	OFF
	RR LH OUT SOL	OFF	OFF	ON*	OFF	OFF	OFF
REAR SOL	RR RH IN SOL	OFF	ON	ON	OFF	OFF	OFF
	RR RH OUT SOL	OFF	OFF	ON*	OFF	OFF	OFF
	RR LH IN SOL	OFF	ON	ON	OFF	OFF	OFF
	RR LH OUT SOL	OFF	OFF	ON*	OFF	OFF	OFF

*: ON for 1 to 2 seconds after the touch, and then OFF

NOTE:

- If active test is performed with brake pedal depressed, pedal stroke may change. This is normal.
- "TEST IS STOPPED" is displayed approximately 10 seconds after operation starts.
- After "TEST IS STOPPED" is displayed, to perform test again, repeat Step 6.

TROUBLE DIAGNOSIS

[VDC/TCS/ABS]

ABS Motor

Touch "ON" and "OFF" on the screen. Check that ABS motor relay operates as shown in table below.

Operation	ON	OFF
ABS actuator relay	ON	ON
ABS motor relay	ON	OFF

NOTE:

- If active test is performed with brake pedal depressed, pedal stroke may change. This is normal.
- "TEST IS STOPPED" is displayed approximately 10 seconds after operation starts.

ACTIVE TEST			
ABS MOTOR		OFF	
MONITOR			
MOTOR RELAY		OFF	
ACTUATOR RLY		ON	
ON			
MODE	BACK	LIGHT	COPY

SFIA0593E

TROUBLE DIAGNOSIS FOR SELF-DIAGNOSTIC ITEMS

PFP:00000

Wheel Sensor System Inspection

EFS004S7

INSPECTION PROCEDURE

1. CONNECTOR INSPECTION

Disconnect the ABS actuator and electric unit (control unit) connector E125 and wheel sensor of malfunctioning code.

Check the terminals for deformation, disconnection, looseness or damage.

OK or NG

OK >> GO TO 2.

NG >> Repair or replace as necessary.

2. CHECK WHEEL SENSOR OUTPUT SIGNAL

1. Connect ABS active wheel sensor tester (J-45741) to wheel sensor using appropriate adapter.

2. Turn on the ABS active wheel sensor tester power switch.

NOTE:

The green POWER indicator should illuminate. If the POWER indicator does not illuminate, replace the battery in the ABS active wheel sensor tester before proceeding.

3. Spin the wheel of the vehicle by hand and observe the red SENSOR indicator on the ABS active wheel sensor tester. The red SENSOR indicator should flash on and off to indicate an output signal.

NOTE:

If the red SENSOR indicator illuminates but does not flash, reverse the polarity of the tester leads and retest.

Does the ABS active wheel sensor tester detect a signal?

YES >> GO TO 3.

NO >> Replace the wheel sensor. Refer to [BRC-150, "Removal and Installation"](#).

3. CHECK TIRES

Check for inflation pressure, wear and size of each tire.

Are tire pressure and size correct and is tire wear within specifications?

YES >> GO TO 4.

NO >> Adjust tire pressure or replace tire(s).

4. CHECK WHEEL BEARINGS

Check wheel bearing axial end play. Refer to [FAX-5, "WHEEL BEARING INSPECTION"](#) or [RAX-5, "WHEEL BEARING INSPECTION"](#).

OK or NG

OK >> GO TO 5.

NG >> Repair or replace as necessary. Refer to [FAX-5, "Removal and Installation"](#) or [RAX-6, "Removal and Installation"](#).

5. CHECK WIRING HARNESS FOR SHORT CIRCUIT

1. Disconnect ABS actuator and electric unit (control unit) connector and wheel sensor connector of malfunction code No.

2. Check resistance between wheel sensor harness connector terminals and ground.

Continuity should not exist.

OK or NG

OK >> GO TO 6.

NG >> Repair the circuit.

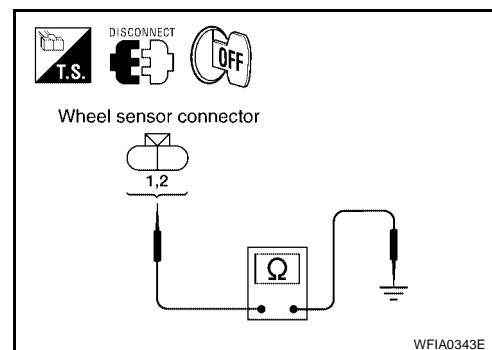

TROUBLE DIAGNOSIS FOR SELF-DIAGNOSTIC ITEMS

[VDC/TCS/ABS]

6. CHECK WIRING HARNESS FOR OPEN CIRCUIT

Check continuity between ABS actuator and electric unit (control unit) harness connector E125 and the malfunctioning wheel sensor harness connector E18, E117, C10, or C11.

Wheel sensor	ABS actuator and electric unit (control unit)		Wheel sensor		Continuity
	Connector - terminal	Wire color	Connector - terminal	Wire color	
Front LH	E125 - 45	G/O	E18 - 1	G/O	Yes
	E125 - 46	BR/W	E18 - 2	BR/W	
Front RH	E125 - 34	B/R	E117 - 1	B/R	
	E125 - 33	BR	E117 - 2	BR	
Rear LH	E125 - 37	P	C11 - 2	P	
	E125 - 36	L	C11 - 1	L	
Rear RH	E125 - 42	V	C10 - 2	V	
	E125 - 43	G/Y	C10 - 1	G/Y	

Continuity should exist.

OK or NG

OK >> Replace the ABS actuator and electric unit (control unit). Refer to [BRC-152, "Removal and Installation"](#).

NG >> Repair the circuit.

Engine System Inspection

EFS004S8

INSPECTION PROCEDURE

1. SELF-DIAGNOSIS RESULT CHECK

Check self-diagnosis results.

Self-diagnosis results
ENGINE SIGNAL 1
ENGINE SIGNAL 2
ENGINE SIGNAL 3
ENGINE SIGNAL 4
ENGINE SIGNAL 6

Is the above displayed in the self-diagnosis display items?

YES >> GO TO 2.

NO >> Inspection End.

2. ENGINE SYSTEM INSPECTION

1. Perform ECM self-diagnosis and repair as necessary. Refer to [EC-127, "SELF-DIAG RESULTS MODE"](#).

2. Perform ABS actuator and electric unit (control unit) self-diagnosis again.

OK or NG

OK >> Inspection End.

NG >> Repair or replace as necessary.

ABS/TCS/VDC Control Unit Inspection

EFS004S9

INSPECTION PROCEDURE

1. SELF-DIAGNOSIS RESULT CHECK

Check self-diagnosis results.

Self-diagnosis results
CONTROLLER FAILURE

Is the above displayed in the self-diagnosis display items?

- YES >> Replace ABS actuator and electric unit (control unit). Refer to [BRC-152, "Removal and Installation"](#).
- NO >> Inspection End.

Steering Angle Sensor System

EFS004SA

INSPECTION PROCEDURE

1. CHECK SELF-DIAGNOSIS RESULT

Check self-diagnosis results.

Self-diagnosis results
ST ANGLE SEN CIRCUIT
ST ANG SEN COM CIR

Is above displayed in self-diagnosis item?

- YES >> GO TO 2.
- NO >> Inspection End.

2. CHECK CONNECTOR

1. Disconnect steering angle sensor connector M47 and ABS actuator and electric unit (control unit) connector E125 and check terminals for deformation, disconnection, looseness, or damage. Repair or replace as necessary.
2. Reconnect connectors and repeat ABS actuator and electric unit (control unit) self-diagnosis.

IS "ST ANGLE SEN CIRCUIT" or "ST ANG SEN COM CIR" DISPLAYED?

- YES >> GO TO 3.
- NO >> Inspection End.

3. CHECK STEERING ANGLE SENSOR HARNESS

1. Check CAN communication system. Refer to [LAN-7, "CAN COMMUNICATION"](#).
2. Turn ignition switch OFF and disconnect steering angle sensor connector M47 and ABS actuator and electric unit (control unit) connector E125.
3. Check continuity between ABS actuator and electric unit (control unit) connector E125 and steering angle sensor connector M47.

ABS actuator and electric unit (control unit) harness connector E125	Steering angle sensor harness connector M47	Continuity
11 (L)	3 (L)	Yes
15 (P)	4 (P)	Yes

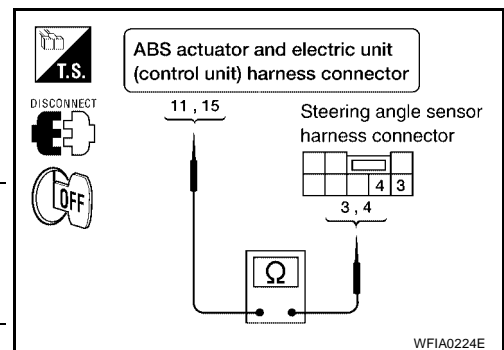

OK or NG

- OK >> GO TO 4.
- NG >> Repair or replace harness.

4. CHECK DATA MONITOR

1. Connect steering angle sensor and ABS actuator and electric unit (control unit) connectors.
2. Use "DATA MONITOR" to check if the status of "STR ANGLE SIG" is normal.

Steering condition	Data monitor
Straight-ahead	-3.5 deg to +3.5 deg
Turn wheel to the right by 90°	Approx. - 90deg
Turn wheel to the left by 90°	Approx. + 90deg

OK or NG

- OK >> Perform ABS actuator and electric unit (control unit) self-diagnosis again.
 NG >> Replace spiral cable (steering angle sensor) and adjust neutral position of steering angle sensor.
 Refer to [BRC-148, "Adjustment of Steering Angle Sensor Neutral Position"](#) .

Yaw Rate/Side/Decel G Sensor System Inspection

EFS004SB

CAUTION:

Sudden turns (such as spin turns, acceleration turns), drifting, etc. when VDC function is OFF may cause the yaw rate/side/decel G sensor system to indicate a problem. This is not a problem if normal operation can be resumed after restarting the engine.

INSPECTION PROCEDURE

1. SELF-DIAGNOSIS RESULT CHECK

Check self-diagnosis results.

Self-diagnosis results
YAW RATE SENSOR
SIDE G-SEN CIRCUIT
G-SENSOR

CAUTION:

If vehicle is on turn table at entrance to parking garage, or on other moving surface, VDC OFF indicator lamp may illuminate and CONSULT-II self-diagnosis may indicate yaw rate sensor system malfunction. However, in this case there is no malfunction in yaw rate sensor system. Take vehicle off of turn table or other moving surface, and start engine. Results will return to normal.

Is the above displayed in the self-diagnosis display items?

- YES >> GO TO 2.
 NO >> Inspection End.

2. CONNECTOR INSPECTION

Disconnect the ABS actuator and electric unit (control unit) connector E125 and yaw rate/side/decel G sensor connector M108.

Check the terminals for deformation, disconnection, looseness or damage.

OK or NG

- OK >> GO TO 3.
 NG >> Repair or replace as necessary.

TROUBLE DIAGNOSIS FOR SELF-DIAGNOSTIC ITEMS

[VDC/TCS/ABS]

3. YAW RATE/SIDE/DECEL G SENSOR HARNESS INSPECTION

1. Turn off the ignition switch and disconnect yaw rate/side/decel G sensor connector M108 and ABS actuator and electric unit (control unit) connector E125.
2. Check continuity between the ABS actuator and electric unit (control unit) connector E125 and the yaw rate/side/decel G sensor connector M108.

ABS actuator and electric unit (control unit) harness connector E125	Yaw rate/side/decel G sensor harness connector M108	Continuity
6 (Y/R)	3 (Y/R)	Yes
24 (P)	5 (P)	
25 (G/R)	1 (G/R)	
29 (G/W)	2 (G/W)	

OK or NG

OK >> GO TO 4.

NG >> Repair or replace as necessary.

4. YAW RATE/SIDE/DECEL G SENSOR INSPECTION

1. Connect the yaw rate/side/decel G sensor connector M108 and ABS actuator and electric unit (control unit) connector E125.
2. Use "DATA MONITOR" to check if the yaw rate/side/decel G sensor signals are normal.

Vehicle status	Yaw rate sensor (Data monitor standard)	Side G sensor (Data monitor standard)	Decel G Sensor (Data monitor standard)
When stopped	-4 to +4 deg/s	-1.1 to +1.1 m/s	-0.11 G to +0.11 G
Right turn	Negative value	Negative value	-
Left turn	Positive value	Positive value	-
Speed up	-	-	Negative value
Speed down	-	-	Positive value

OK or NG

OK >> Inspection End.

NG >> Replace the yaw rate/side/decel G sensor. Refer to [BRC-155, "Removal and Installation"](#).

Solenoid and VDC Change-Over Valve System Inspection

INSPECTION PROCEDURE

1. SELF-DIAGNOSIS RESULT CHECK

Check self-diagnosis results.

Self-diagnosis results
FR LH IN ABS SOL
FR LH OUT ABS SOL
RR RH IN ABS SOL
RR RH OUT ABS SOL
FR RH IN ABS SOL
FR RH OUT ABS SOL
RR LH IN ABS SOL
RR LH OUT ABS SOL
CV 1
CV 2
SV 1
SV 2

Is the above displayed in the self-diagnosis display items?

YES >> GO TO 2.

NO >> Inspection End.

2. CONNECTOR INSPECTION

1. Disconnect ABS actuator and electric unit (control unit) connector E125.
2. Check the terminals for deformation, disconnection, looseness or damage.

OK or NG

OK >> GO TO 3.

NG >> Repair or replace as necessary.

3. CHECKING SOLENOID POWER AND GROUND

1. Check voltage between ABS actuator and electric unit (control unit) harness connector E125 and body ground.

ABS actuator and electric unit (control unit) connector E125	Body ground	Measured value (Approx.)
32 (B/Y)	—	12V

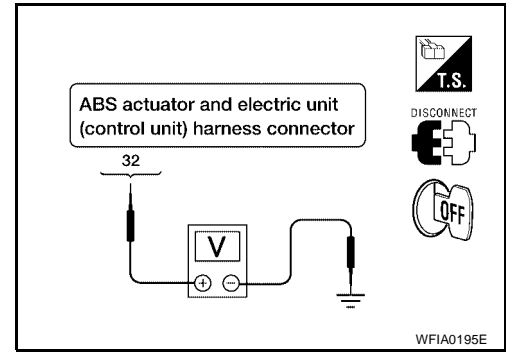

2. Check resistance between ABS actuator and electric unit (control unit) harness connector E125 and body ground.

ABS actuator and electric unit (control unit) connector E125	Body ground	Measured value Ω (Approx.)
16 (B)	—	0Ω
47 (B)	—	0Ω

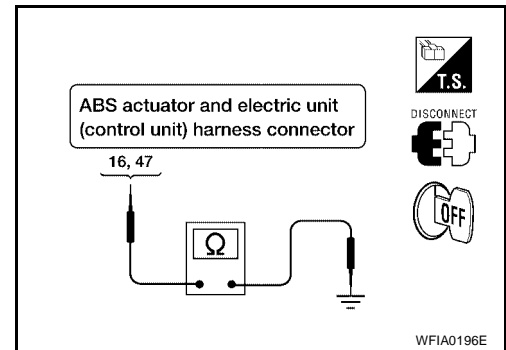

OK or NG

OK >> Perform self-diagnosis again. If the same results appear, replace ABS actuator and electric unit (control unit). Refer to [BRC-152, "Removal and Installation"](#).

NG >> Repair the circuit.

Actuator Motor, Motor Relay, and Circuit Inspection

EF5004SD

INSPECTION PROCEDURE

1. CHECKING SELF-DIAGNOSIS RESULTS

Check self-diagnosis results.

Self-diagnosis results
PUMP MOTOR
ACTUATOR RLY

Is the above displayed in the self-diagnosis display items?

YES >> GO TO 2.

NO >> Inspection End.

2. CONNECTOR INSPECTION

1. Disconnect ABS actuator and electric unit (control unit) connector E125.
2. Check the terminals for deformation, disconnection, looseness or damage.

OK or NG

OK >> GO TO 3.

NG >> Repair or replace as necessary.

3. CHECKING ABS MOTOR AND MOTOR RELAY POWER SYSTEM

1. Check voltage between ABS actuator and electric unit (control unit) harness connector E125 and body ground.

ABS actuator and electric unit (control unit) connector E125	Body ground	Measured value (Approx.)
1 (Y)	—	12V

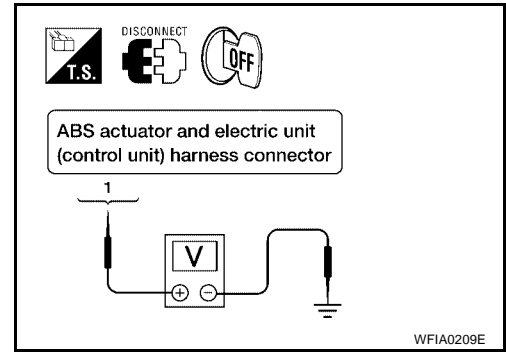

2. Check resistance between ABS actuator and electric unit (control unit) connector E125 and body ground.

ABS actuator and electric unit (control unit) harness connector E125	Body ground	Measured value Ω (Approx.)
16 (B)	—	0Ω
47 (B)	—	0Ω

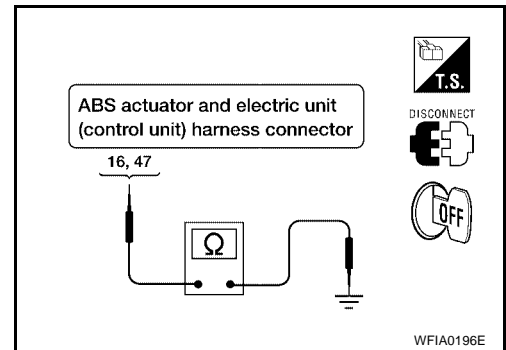

OK or NG

- OK >> Perform self-diagnosis again. If the same results appear, replace ABS actuator and electric unit (control unit). Refer to [BRC-152, "Removal and Installation"](#).
- NG >> Repair the circuit.

Stop Lamp Switch System Inspection

EFS004SE

INSPECTION PROCEDURE

1. SELF-DIAGNOSIS RESULT CHECK

Check self-diagnosis results.

Self-diagnosis results
STOP LAMP SW

Is the above displayed in the self-diagnosis display items?

- YES >> GO TO 2.
- NO >> Inspection End.

2. CONNECTOR INSPECTION

1. Disconnect the ABS actuator and electric unit (control unit) connector E125 and stop lamp switch connector E38.
2. Check the terminals for deformation, disconnection, looseness or damage.

OK or NG

- OK >> GO TO 3.
- NG >> Repair or replace as necessary.

3. STOP LAMP SWITCH INSPECTION

Check the voltage between the ABS actuator and electric unit (control unit) harness connector E125 terminal 41 (R/B) and body ground.

Brake pedal depressed : Battery voltage (approx. 12V)

Brake pedal not depressed : Approx. 0V

OK or NG

OK >> Perform self-diagnosis again. If the same results appear, replace ABS actuator and electric unit (control unit). Refer to [BRC-152, "Removal and Installation"](#).

NG >> GO TO 4.

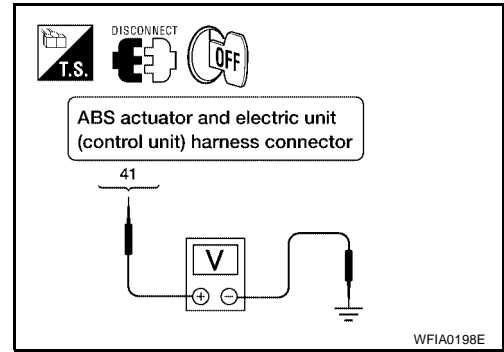

4. STOP LAMP RELAY CIRCUIT INSPECTION

1. Disconnect the stop lamp relay harness connector E12.
2. Check the continuity between the ABS actuator and electric unit (control unit) harness connector E125 terminal 41 (R/B) and stop lamp relay harness connector E12 terminal 4 (R/B).

Continuity should exist

OK or NG

OK >> Perform self-diagnosis again. If the same results appear, replace ABS actuator and electric unit (control unit). Refer to [BRC-152, "Removal and Installation"](#).

NG >> Refer to [LT-98, "STOP LAMP"](#).

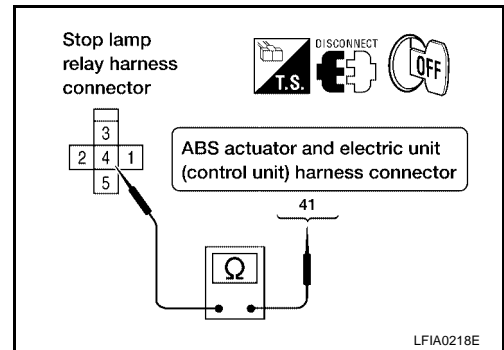

ABS/TCS/VDC Control Unit Power and Ground Systems Inspection

EF5004SF

INSPECTION PROCEDURE

1. SELF-DIAGNOSIS RESULT CHECK

Check self-diagnosis results.

Self-diagnosis results
BATTERY VOLTAGE

Is the above displayed in the self-diagnosis display items?

YES >> GO TO 2.

NO >> Inspection End.

2. CONNECTOR INSPECTION

1. Disconnect the ABS actuator and electric unit (control unit) connector E125.
2. Check the terminals for deformation, disconnection, looseness or damage.

OK or NG

OK >> GO TO 3.

NG >> Repair or replace as necessary.

A
B
C
D
E
BRC
G
H
I
J
K
L
M

TROUBLE DIAGNOSIS FOR SELF-DIAGNOSTIC ITEMS

[VDC/TCS/ABS]

3. ABS/TCS/VDC CONTROL UNIT POWER AND GROUND CIRCUIT INSPECTION

Measure the voltage and continuity between the ABS actuator and electric unit (control unit) harness connector E125 and body ground.

Signal name	ABS actuator and electric unit (control unit) harness connector E125	Body ground	Measured value
Power supply	1 (Y)	—	Battery voltage (Approx. 12V)
	32 (B/Y)		
Ground	16 (B)	—	Continuity should exist.
	47 (B)		

OK or NG

- OK >> Check the battery for loose terminals, low voltage, etc. Repair as necessary.
- NG >> Repair the circuit.

Brake Fluid Level Sensor System Inspection

EF5004SG

INSPECTION PROCEDURE

1. SELF-DIAGNOSIS RESULT CHECK

1. Check the brake reservoir tank fluid level. If the level is low, add brake fluid.
2. Erase the self-diagnosis results and check the self-diagnosis results.

Self-diagnosis results

BR FLUID LEVEL LOW

Is the above displayed in the self-diagnosis display items?

- YES >> GO TO 2.
- NO >> Inspection End.

2. CONNECTOR INSPECTION

1. Disconnect the ABS actuator and electric unit (control unit) connector E125 and brake fluid level switch connector E21.
2. Check the terminals for deformation, disconnection, looseness or damage.

OK or NG

- OK >> GO TO 3.
- NG >> Repair or replace as necessary.

TROUBLE DIAGNOSIS FOR SELF-DIAGNOSTIC ITEMS

[VDC/TCS/ABS]

3. CHECK THE HARNESS BETWEEN THE BRAKE FLUID LEVEL SENSOR AND THE ABS ACTUATOR AND ELECTRIC UNIT (CONTROL UNIT)

Check the continuity between the brake fluid level switch harness connector E21 and the ABS actuator and electric unit (control unit) harness connector E125.

ABS actuator and electric unit (control unit) harness connector E125	Brake fluid level switch harness connector E21	Continuity
8 (P/B)	1 (P/B)	Yes
8 (P/B)	Ground	No
Ground	2 (B)	Yes

OK or NG

OK >> Perform self-diagnosis again. If the same results appear, replace ABS actuator and electric unit (control unit). Refer to [BRC-152, "Removal and Installation"](#).

NG >> Repair the circuit.

Active Booster System Inspection

EFS004SH

BRC

INSPECTION PROCEDURE

1. DISPLAY SELF DIAGNOSIS RESULTS

Check self-diagnosis results.

Self-diagnosis results
ABS ACTIVEBOOSTER SV NG
ABS ACTIVEBOOSTER RESPONSE
ABS BRAKE RELEASE SWITCH NG
ABS BRAKEBOOSTER DEFECT

Is the above displayed in the self-diagnosis display items?

YES or NO

YES >> GO TO 2.

NO >> Inspection End.

2. CONNECTOR INSPECTION

1. Turn the ignition switch OFF.
2. Disconnect the active booster connector E49 and ABS actuator and electric unit (control unit) connector E125 and inspect the terminals for deformation, disconnection, looseness, or damage.

OK or NG

OK >> GO TO 3.

NG >> Repair connector.

TROUBLE DIAGNOSIS FOR SELF-DIAGNOSTIC ITEMS

[VDC/TCS/ABS]

3. ACTIVE BOOSTER CIRCUIT INSPECTION

1. Measure the continuity between the ABS actuator and electric unit (control unit) connector E125 and active booster connector E49.

ABS actuator and electric unit (control unit) connector E125	Active booster connector E49	Continuity
17 (W/R)	3 (W/R)	Yes
27 (L/B)	1 (L/B)	
28 (Y/B)	5 (Y/B)	
30 (LG/R)	2 (LG/R)	
31 (W/G)	4 (W/G)	

2. Measure the continuity between the ABS actuator and electric unit (control unit) connector E125 and body ground.

ABS actuator and electric unit (control unit) connector E125	Body ground	Continuity
17 (W/R)	—	No
27 (L/B)		
28 (Y/B)		
30 (LG/R)		
31 (W/G)		

OK or NG

- OK >> GO TO 4.
- NG >> Repair or replace harness or connector.

4. ACTIVE BOOSTER SENSOR INSPECTION

1. Reconnect the active booster and ABS actuator and electric unit (control unit) connectors.
2. Use "DATA MONITOR" to check if the status of "RELEASE SW NO" and "RELEASE SW NC" is normal.

Condition	Data monitor display	
	RELEASE SW NO	RELEASE SW NC
When brake pedal is depressed	ON	OFF
When brake pedal is released	OFF	ON

OK or NG

- OK >> Inspection End.
- NG >> Replace active booster. Refer to [BR-19, "With ABS or BLSD"](#).

Delta Stroke Sensor System Inspection

EFS004SI

INSPECTION PROCEDURE

1. DISPLAY SELF DIAGNOSIS RESULTS

Check self-diagnosis results.

Self-diagnosis results
DELTA S SEN NG

Is the above displayed in the self-diagnosis display items?

YES or NO

- YES >> GO TO 2.
- NO >> Inspection End.

TROUBLE DIAGNOSIS FOR SELF-DIAGNOSTIC ITEMS

[VDC/TCS/ABS]

2. CONNECTOR INSPECTION

1. Turn the ignition switch OFF.
2. Disconnect the delta stroke sensor connector E114 and ABS actuator and electric unit (control unit) connector E125 and inspect the terminals for deformation, disconnection, looseness, or damage.

OK or NG

- OK >> GO TO 3.
NG >> Repair connector.

3. DELTA STROKE SENSOR CIRCUIT INSPECTION

1. Measure the continuity between the ABS actuator and electric unit (control unit) connector E125 and delta stroke sensor connector E114.

ABS actuator and electric unit (control unit) connector E125	Delta stroke sensor connector E114	Continuity
26 (W/V)	1 (W/V)	Yes
39 (G/B)	3 (G/B)	
40 (R/Y)	5 (R/Y)	

2. Measure the continuity between the ABS actuator and electric unit (control unit) connector E125 and body ground.

ABS actuator and electric unit (control unit) connector E125	Body ground	Continuity
26 (W/V)	—	No
39 (G/B)		
40 (R/Y)		

OK or NG

- OK >> GO TO 4.
NG >> Repair or replace harness or connector.

4. DELTA STROKE SENSOR INSPECTION

1. Reconnect the delta stroke sensor and ABS actuator and electric unit (control unit) connectors.
2. Use "DATA MONITOR" to check if the status of "DELTA S SEN" is normal.

Condition	Data monitor display (Approx.)
	DELTA S SEN
When brake pedal is depressed	0.00 mm (+0.6/-0.4)
When brake pedal is released	1.05–1.80 mm

OK or NG

- OK >> Inspection End.
NG >> Replace delta stroke sensor. Refer to [BR-19, "With ABS or BLSD"](#) .

TROUBLE DIAGNOSIS FOR SELF-DIAGNOSTIC ITEMS

[VDC/TCS/ABS]

EFS004SJ

Pressure Sensor System Inspection

FRONT PRESSURE INSPECTION PROCEDURE

1. DISPLAY SELF DIAGNOSIS RESULTS

Check self-diagnosis results.

Self-diagnosis results

PRESS SEN CIRCUIT

Is the above displayed in the self-diagnosis display items?

YES or NO

YES >> GO TO 2.

NO >> Inspection End.

2. CONNECTOR INSPECTION

1. Turn the ignition switch OFF.
2. Disconnect the front pressure sensor connector E31 and ABS actuator and electric unit (control unit) connector E125 and inspect the terminals for deformation, disconnection, looseness, or damage.

OK or NG

OK >> GO TO 3.

NG >> Repair connector.

3. FRONT PRESSURE SENSOR CIRCUIT INSPECTION

1. Measure the continuity between the ABS actuator and electric unit (control unit) harness connector E125 and front pressure sensor harness connector E31.

ABS actuator and electric unit (control unit) harness connector E125	Front pressure sensor harness connector E31	Continuity
18 (LG)	3 (LG)	Yes
19 (SB)	1 (SB)	
20 (R/L)	2 (R/L)	

2. Measure the continuity between the ABS actuator and electric unit (control unit) harness connector E125 and body ground.

ABS actuator and electric unit (control unit) harness connector E125	Body ground	Continuity
18 (LG)	—	No
19 (SB)		
20 (R/L)		

OK or NG

OK >> GO TO 4.

NG >> Repair or replace harness or connector.

TROUBLE DIAGNOSIS FOR SELF-DIAGNOSTIC ITEMS

[VDC/TCS/ABS]

4. FRONT PRESSURE SENSOR INSPECTION

1. Reconnect the front pressure sensor and ABS actuator and electric unit (control unit) connectors.
2. Use "DATA MONITOR" to check if the status of "PRESS SENSOR" is normal.

Condition	Data monitor display (Approx.)
	PRESS SENSOR
When brake pedal is depressed	Positive value
When brake pedal is released	0 bar

OK or NG

- OK >> Inspection End.
NG >> Replace front pressure sensor. Refer to [BR-15, "With ABS"](#).

REAR PRESSURE INSPECTION PROCEDURE

1. DISPLAY SELF DIAGNOSIS RESULTS

Check self-diagnosis results.

Self-diagnosis results
PRESS SEN CIRCUIT

Is the above displayed in the self-diagnosis display items?

YES or NO

- YES >> GO TO 2.
NO >> Inspection End.

2. CONNECTOR INSPECTION

1. Turn the ignition switch OFF.
2. Disconnect the rear pressure sensor connector E32 and ABS actuator and electric unit (control unit) connector E125 and inspect the terminals for deformation, disconnection, looseness, or damage.

OK or NG

- OK >> GO TO 3.
NG >> Repair connector.

A
B
C
D
E
BRC
G
H
I
J
K
L
M

TROUBLE DIAGNOSIS FOR SELF-DIAGNOSTIC ITEMS

[VDC/TCS/ABS]

3. REAR PRESSURE SENSOR CIRCUIT INSPECTION

1. Measure the continuity between the ABS actuator and electric unit (control unit) connector E125 and rear pressure sensor connector E32.

ABS actuator and electric unit (control unit) connector E125	Rear pressure sensor connector E32	Continuity
21 (R/G)	1 (R/G)	Yes
22 (W/L)	3 (W/L)	
23 (W/O)	2 (W/O)	

2. Measure the continuity between the ABS actuator and electric unit (control unit) connector E125 and body ground.

ABS actuator and electric unit (control unit) connector E125	Body ground	Continuity
21 (R/G)	—	No
22 (W/L)		
23 (W/O)		

OK or NG

- OK >> GO TO 4.
- NG >> Repair or replace harness or connector.

4. REAR PRESSURE SENSOR INSPECTION

1. Reconnect the rear pressure sensor and ABS actuator and electric unit (control unit) connectors.
2. Use "DATA MONITOR" to check if the status of "PRESS SEN 2" is normal.

Condition	Data monitor display (Approx.)
	PRESS SEN 2
When brake pedal is depressed	Positive value
When brake pedal is released	0 bar

OK or NG

- OK >> Inspection End.
- NG >> Replace rear pressure sensor. Refer to [BR-15, "With ABS"](#) .

CAN Communication System Inspection

EFS004SK

INSPECTION PROCEDURE

1. CHECK CONNECTOR

1. Turn ignition switch OFF, disconnect the ABS actuator and electric unit (control unit) connector and check the terminals for deformation, disconnection, looseness, and so on. If there is a malfunction, repair or replace the terminal.
2. Reconnect connector to perform self-diagnosis.

Is "CAN COMM CIRCUIT" displayed in self-diagnosis display items?

- YES >> Print out the self-diagnostic results, and refer to [LAN-7, "CAN COMMUNICATION"](#) .
- NO >> Connector terminal is loose, damaged, open, or shorted.

TROUBLE DIAGNOSIS FOR SELF-DIAGNOSTIC ITEMS

[VDC/TCS/ABS]

Inspection For Self-diagnosis Result "ST ANGLE SEN SIGNAL"

EFS004SL

INSPECTION PROCEDURE

1. PERFORM SELF-DIAGNOSIS

Check self-diagnosis results.

Self-diagnosis results

ST ANGLE SEN SIGNAL

Do self-diagnosis results indicate anything other than shown above?

YES >> Perform repair or replacement for the item indicated.

NO >> Perform adjustment of steering angle sensor neutral position. Refer to [BRC-148, "Adjustment of Steering Angle Sensor Neutral Position"](#) . GO TO 2.

2. PERFORM SELF-DIAGNOSIS AGAIN

1. Turn the ignition switch to OFF and then to ON and erase self-diagnosis results.

2. Perform ABS actuator and electric unit (control unit) self-diagnosis again.

Are any self-diagnosis results displayed?

YES >> Replace steering angle sensor. Refer to [BRC-154, "Removal and Installation"](#) .

NO >> Inspection End.

Inspection For Self-diagnosis Result "DECEL G SEN SET"

EFS004SM

INSPECTION PROCEDURE

1. PERFORM SELF-DIAGNOSIS

Check self-diagnosis results.

Self-diagnosis results

DECEL G SEN SET

Do self-diagnosis results indicate anything other than shown above?

YES >> Perform repair or replacement for the item indicated.

NO >> Perform calibration of yaw rate/side/decel G sensor. Refer to [BRC-148, "Calibration of Yaw Rate/Side/Decel G Sensor"](#) . GO TO 2.

2. PERFORM SELF-DIAGNOSIS AGAIN

1. Turn the ignition switch to OFF and then to ON and erase self-diagnosis results.

2. Perform ABS actuator and electric unit (control unit) self-diagnosis again.

Are any self-diagnosis results displayed?

YES >> Replace yaw rate/side/decel G sensor. Refer to [BRC-155, "Removal and Installation"](#) .

NO >> Inspection End.

VDC OFF Indicator lamp Does Not Illuminate

EFS004SN

INSPECTION PROCEDURE

1. CHECK VDC OFF INDICATOR LAMP

Disconnect ABS actuator and electric unit (control unit) connector E125.

Do the ABS warning lamp and VDC OFF indicator lamp illuminate?

YES >> Replace ABS actuator and electric unit (control unit). Refer to [BRC-152, "Removal and Installation"](#) .

NO >> Replace combination meter. Refer to [IP-13, "COMBINATION METER"](#) .

TROUBLE DIAGNOSIS FOR SELF-DIAGNOSTIC ITEMS

[VDC/TCS/ABS]

Component Inspection

VDC OFF SWITCH

EFS004SO

Check the continuity between terminals 1 and 2.

- 1 - 2 : Continuity should exist when pushing the switch.**
- Continuity should not exist when releasing the switch.**

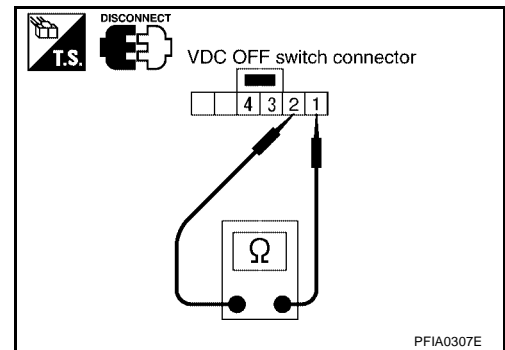

TROUBLE DIAGNOSES FOR SYMPTOMS

PFP:99999

ABS Works Frequently

EFS005FS

1. CHECK WARNING LAMP ACTIVATION

Make sure warning lamp remains off while driving.

OK or NG

OK >> GO TO 2.

NG >> Carry out self-diagnosis. Refer to [BRC-116, "SELF-DIAGNOSIS"](#) .

2. CHECK WHEEL SENSORS

Check the following.

- Wheel sensor mounting for looseness
- Wheel sensors for physical damage
- Wheel sensor connectors for terminal damage or loose connections
- Sensor rotor and mount for physical damage (rear only)

OK or NG

OK >> GO TO 3.

NG >> Repair or replace as necessary.

3. CHECK FRONT AND REAR AXLES

Check front and rear axles for excessive looseness. Refer to [FAX-5, "WHEEL BEARING INSPECTION"](#) or [RAX-5, "WHEEL BEARING INSPECTION"](#) .

OK or NG

OK >> GO TO 4.

NG >> Repair as necessary.

4. CHECK BRAKE FLUID PRESSURE

Check brake fluid pressure distribution.

Refer to [BRC-110, "Basic Inspection"](#) .

Is brake fluid pressure distribution normal?

YES >> Inspection End.

NO >> Perform Basic Inspection. Refer to [BRC-110, "Basic Inspection"](#) .

A

B

C

D

E

BRC

G

H

I

J

K

L

M

Unexpected Pedal Action

1. CHECK WARNING LAMP ACTIVATION

Make sure warning lamp remains off while driving.

OK or NG

OK >> GO TO 2.

NG >> Carry out self-diagnosis. Refer to [BRC-116, "SELF-DIAGNOSIS"](#) .

2. CHECK BRAKE PEDAL STROKE

Check brake pedal stroke.

Is pedal stroke excessive?

YES >> Perform Basic Inspection. Refer to [BRC-110, "Basic Inspection"](#) .

NO >> GO TO 3.

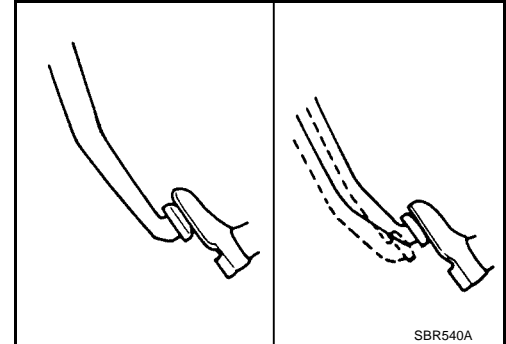

3. CHECK CONNECTOR AND BRAKING PERFORMANCE

1. Disable ABS by disconnecting ABS actuator and electric unit (control unit) connector.

2. Drive vehicle and check brake operation.

NOTE:

- Stopping distance may be longer than vehicles without ABS when road condition is slippery.
- Driving the vehicle with the ABS actuator and electric unit (control unit) disconnected may induce DTCs in electrical control units using CAN communication. After the inspection, clear all DTCs. Refer to [LAN-7, "CAN COMMUNICATION"](#) .

OK or NG

OK >> GO TO 4.

NG >> Perform Basic Inspection. Refer to [BRC-110, "Basic Inspection"](#) .

4. CHECK WHEEL SENSORS

Check the following.

- Wheel sensor mounting for looseness
- Wheel sensors for physical damage
- Wheel sensor connectors for terminal damage or loose connections

OK or NG

OK >> Check ABS actuator and electric unit (control unit) connector terminals for deformation, disconnection, looseness or damage. Reconnect ABS actuator and electric unit (control unit) harness connector. Then retest.

NG >> Repair or replace as necessary.

Long Stopping Distance

EFS005FU

1. CHECK BASE BRAKING SYSTEM PERFORMANCE

1. Disable ABS by disconnecting ABS actuator and electric unit (control unit) connector.
2. Drive vehicle and check brake operation.

NOTE:

- Stopping distance may be longer than vehicles without ABS when road condition is slippery.
- Driving the vehicle with the ABS actuator and electric unit (control unit) disconnected may induce DTCs in electrical control units using CAN communication. After the inspection, clear all DTCs. Refer to [LAN-7, "CAN COMMUNICATION"](#).

OK or NG

- OK >> Go to [BRC-143, "ABS Works Frequently"](#).
- NG >> Perform Basic Inspection. Refer to [BRC-110, "Basic Inspection"](#).

ABS Does Not Work

EFS005FV

CAUTION:

The ABS does not operate when the vehicle speed is 10 km/h (6 MPH) or less.

1. CHECK WARNING LAMP ACTIVATION

Turn ignition switch ON and check for warning lamp activation.

- Warning lamp should activate for approximately 2 seconds after turning the ignition switch ON.

OK or NG

- OK >> Carry out self-diagnosis. Refer to [BRC-116, "SELF-DIAGNOSIS"](#).
- NG >> Go to [BRC-146, "ABS Warning Lamp Does Not Come On When Ignition Switch Is Turned On"](#).

Pedal Vibration or ABS Operation Noise

EFS005FW

NOTE:

During ABS activation, pedal vibration may be felt and a noise may be heard. This is normal and does not indicate a malfunction.

1. CHECK SYMPTOM

1. Apply brake.
2. Start engine.

Does the symptom occur only when engine is started?

- YES >> Carry out self-diagnosis. Refer to [BRC-116, "SELF-DIAGNOSIS"](#).
- NO >> GO TO 2.

2. RECHECK SYMPTOM

Does the symptom occur only when electrical equipment switches (such as headlamps) are turned on?

- YES >> Check for radio, antenna or related wiring that is routed too close to the ABS actuator and electric unit (control unit) and reroute as necessary.
- NO >> Go to [BRC-143, "ABS Works Frequently"](#).

ABS Warning Lamp Does Not Come On When Ignition Switch Is Turned On EFS005FX

1. CHECK ABS ACTUATOR AND ELECTRIC UNIT (CONTROL UNIT) FUSES

Check 40A fusible link **i** and 30A fusible link **h** for ABS actuator and electric unit (control unit). For fusible link layout, refer to [PG-4, "POWER SUPPLY ROUTING CIRCUIT"](#) .

OK or NG

OK >> GO TO 2.

NG >> If fusible link is blown, be sure to eliminate cause of problem before replacing.

2. CHECK ABS ACTUATOR AND ELECTRIC UNIT (CONTROL UNIT) POWER SUPPLY CIRCUITS

1. Disconnect ABS actuator and electric unit (control unit) connector.
2. Check voltage between ABS actuator and electric unit (control unit) connector terminal 1 (Y) and ground and terminal 32 (B/Y) and ground.

Does battery voltage exist?

YES >> GO TO 3.

NO >> Repair harness or connectors between fusible link and ABS actuator and electric unit (control unit).

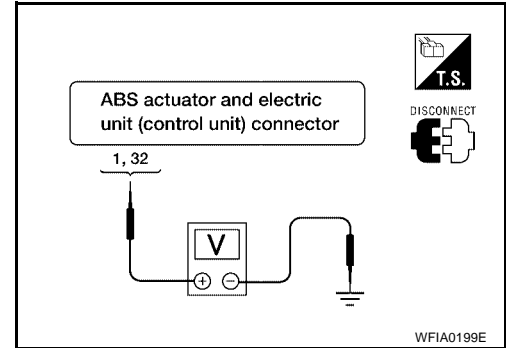

3. CHECK ABS ACTUATOR AND ELECTRIC UNIT (CONTROL UNIT) GROUND CIRCUIT

Check continuity between ABS actuator and electric unit (control unit) connector terminal 16 (B) and ground and terminal 47 (B) and ground.

Does continuity exist?

YES >> Replace ABS actuator and electric unit (control unit). Refer to [BRC-152, "Removal and Installation"](#) .

NO >> Repair harness or connectors between ABS actuator and electric unit (control unit) and ground.

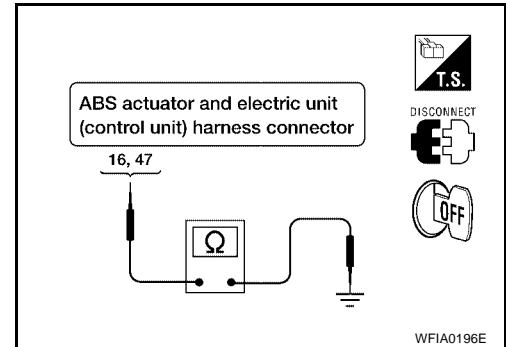

ABS Warning Lamp Stays On When Ignition Switch Is Turned On EFS005FY

1. CARRY OUT SELF-DIAGNOSIS

Carry out self-diagnosis. Refer to [BRC-116, "SELF-DIAGNOSIS"](#) .

Are malfunctions detected in self-diagnosis?

YES >> Refer to [BRC-117, "Display Item List"](#) .

NO >> Refer to [DI-30, "WARNING LAMPS"](#) .

Vehicle Jerks During TCS/VDC Activation**1. ABS ACTUATOR AND ELECTRIC UNIT (CONTROL UNIT) SELF-DIAGNOSIS**

Perform ABS actuator and electric unit (control unit) self-diagnosis.

Are self-diagnosis result items displayed?

- YES >> After checking and repairing the applicable item, perform the ABS actuator and electric unit (control unit) self-diagnosis again.
- NO >> GO TO 2.

2. ENGINE SPEED SIGNAL INSPECTION

Perform data monitor with CONSULT-II for the ABS actuator and electric unit (control unit).

Is the engine speed at idle 400 rpm or higher?

- YES >> GO TO 4.
- NO >> GO TO 3.

3. ECM SELF-DIAGNOSIS

Perform ECM self-diagnosis.

Are self-diagnosis result items displayed?

- YES >> After checking and repairing the applicable item, perform the ECM self-diagnosis again.
- NO >> GO TO 4.

4. TCM SELF-DIAGNOSIS

Perform TCM self-diagnosis.

Are self-diagnosis result items displayed?

- YES >> After checking and repairing the applicable item, perform the TCM self-diagnosis again.
- NO >> GO TO 5.

5. CONNECTOR INSPECTION

Disconnect the ABS actuator and electric unit (control unit) connector and the ECM connectors and check the terminals for deformation, disconnection, looseness or damage.

OK or NG

- OK >> GO TO 6.
- NG >> Repair or replace as necessary.

6. CAN COMMUNICATION INSPECTION

Check the CAN communication system. Refer to [BRC-140, "CAN Communication System Inspection"](#).

OK or NG

- OK >> Inspection End.
- NG >> Refer to [LAN-7, "CAN COMMUNICATION"](#).

A

B

C

D

E

BRC

G

H

I

J

K

L

M

ON-VEHICLE SERVICE**Adjustment of Steering Angle Sensor Neutral Position**

EFS004SX

After removing/installing or replacing ABS actuator and electric unit (control unit), steering angle sensor, steering and suspension components which affect wheel alignment or after adjusting wheel alignment, be sure to adjust neutral position of steering angle sensor before running vehicle.

NOTE:

Adjustment of steering angle sensor neutral position requires CONSULT-II.

1. Stop vehicle with front wheels in straight-ahead position.
2. Connect CONSULT-II and CONSULT-II CONVERTER to data link connector on vehicle, and turn ignition switch ON (do not start engine).
3. Touch "ABS", "WORK SUPPORT" and "ST ANGLE SENSOR ADJUSTMENT" on CONSULT-II screen in this order.

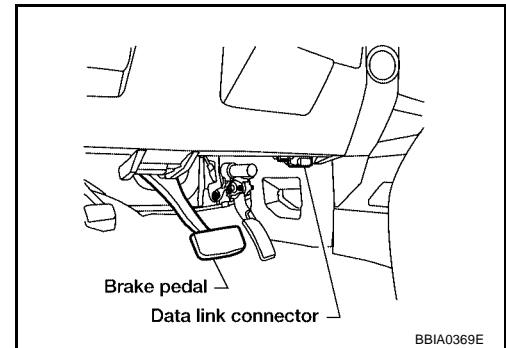

4. Touch "START".

CAUTION:

Do not touch steering wheel while adjusting steering angle sensor.

5. After approximately 10 seconds, touch "END". (After approximately 60 seconds, it ends automatically.)
6. Turn ignition switch OFF, then turn it ON again.
7. Run vehicle with front wheels in straight-ahead position, then stop.
8. Select "DATA MONITOR", "SELECTION FROM MENU", and "STR ANGLE SIG" on CONSULT-II screen. Then check that "STR ANGLE SIG" is within 0 ± 3.5 deg. If value is more than specification, repeat steps 1 to 5.
9. Erase memory of ABS actuator and electric unit (control unit) and ECM.
10. Turn ignition switch to OFF.

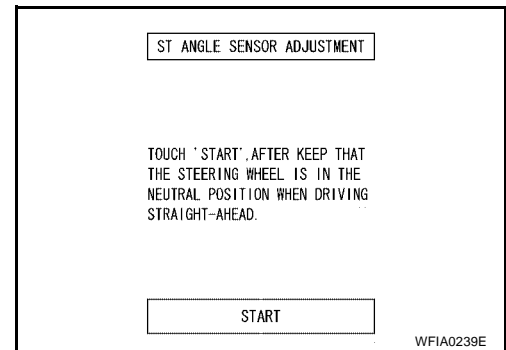
**Calibration of Yaw Rate/Side/Decel G Sensor**

EFS004SY

After removing/installing or replacing ABS actuator and electric unit (control unit), yaw rate/side/decel G sensor, steering and suspension components which affect wheel alignment or after adjusting wheel alignment, be sure to calibrate the yaw rate/side/decel G sensor before running vehicle.

NOTE:

Calibration of yaw rate/side/decel G sensor requires CONSULT-II.

1. Stop vehicle with front wheels in straight-ahead position.

CAUTION:

● **The work should be done on a level area with an unloaded vehicle.**

● **Keep all the tires inflated to the correct pressures. Adjust the tire pressure to the specified pressure value.**

2. Connect CONSULT-II with CONSULT-II CONVERTER to data link connector on vehicle, and turn ignition switch ON (do not start engine).

CAUTION:

If CONSULT-II is used with no connection of CONSULT-II CONVERTER, malfunctions might be detected in self-diagnosis depending on control unit which carries out CAN communication.

3. Touch "ABS", "WORK SUPPORT" and "DECCEL G SEN CALIBRATION" on CONSULT-II screen in this order. Refer to [BRC-115, "CONSULT-II BASIC OPERATION PROCEDURE"](#).

ON-VEHICLE SERVICE

[VDC/TCS/ABS]

4. Touch "START".

CAUTION:

Set vehicle as shown in the display.

5. After approximately 10 seconds, touch "END". (After approximately 60 seconds, it ends automatically.)
6. Turn ignition switch OFF, then turn it ON again.

CAUTION:

Be sure to carry out above operation.

7. Run vehicle with front wheels in straight-ahead position, then stop.
8. Select "DATA MONITOR", "SELECTION FROM MENU", and "DECEL G SEN" on CONSULT-II screen. Then check that "DECEL G SEN" is within $\pm 0.08G$. If value is more than specification, repeat steps 3 to 7.
9. Erase memory of ABS actuator and electric unit (control unit) and ECM.
10. Turn ignition switch to OFF.

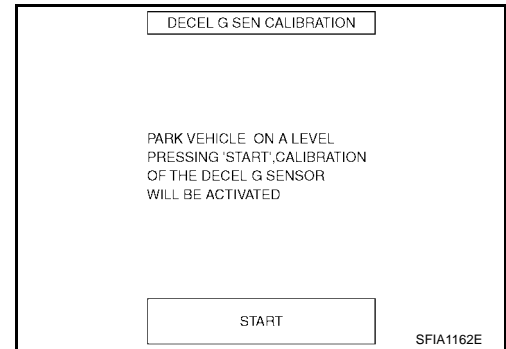

A

B

C

D

E

BRC

G

H

I

J

K

L

M

WHEEL SENSORS

Removal and Installation

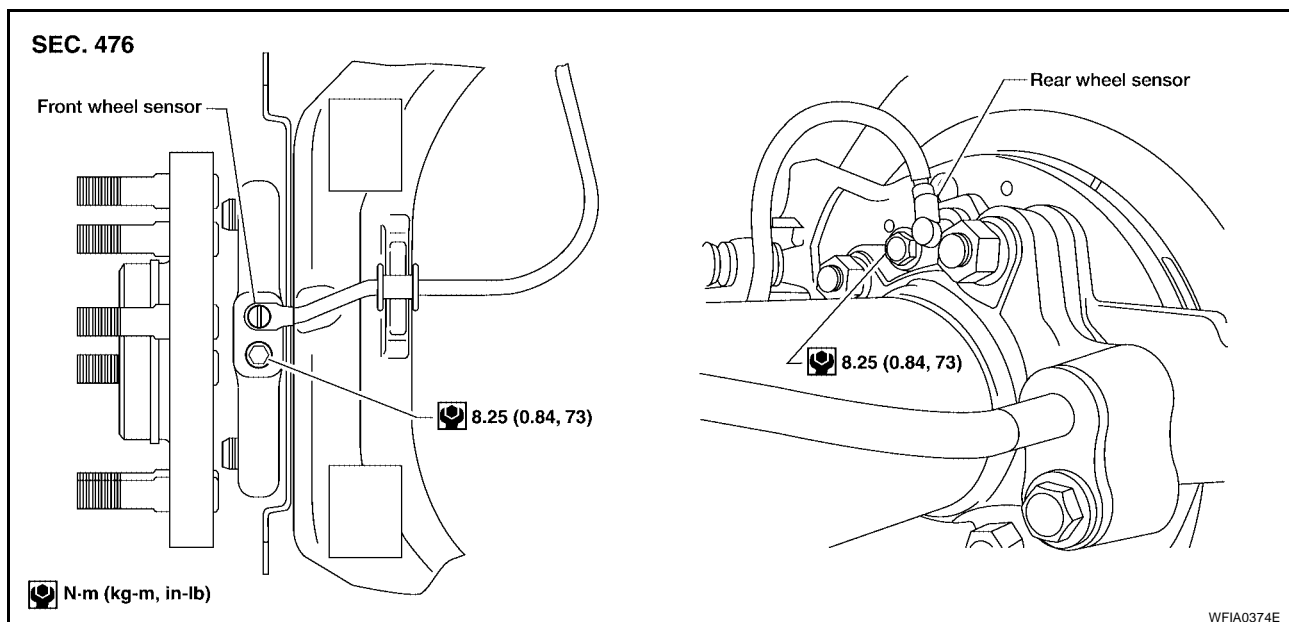

REMOVAL

1. Remove wheel sensor mounting screw.
 - When removing the front wheel sensor, first remove the disc rotor to gain access to the front wheel sensor mounting bolt. Refer to [BR-24, "Removal and Installation of Brake Caliper and Disc Rotor"](#).
2. Pull out the sensor, being careful to turn it as little as possible.

CAUTION:

- Be careful not to damage sensor edge and sensor rotor teeth.
 - Do not pull on the sensor harness.
3. Disconnect wheel sensor harness electrical connector, then remove harness from mounts.

INSTALLATION

Before installing wheel sensors,

- Inspect wheel sensor O-ring, replace sensor assembly if damaged.
- Clean wheel sensor hole and mounting surface with brake cleaner and a lint-free shop rag. Be careful that dirt and debris do not enter the axle.
- Apply a coat of suitable grease to the wheel sensor O-ring and mounting hole.

Installation is in the reverse order of removal.

SENSOR ROTOR

PFP:47970

Removal and Installation FRONT

EFS00470

The wheel sensor rotors are built into the wheel hubs and are not removable. If damaged, replace wheel hub and bearing assembly. Refer to [FAX-5, "Removal and Installation"](#) .

REAR

Removal

1. Remove axle shaft assembly. Refer to [RAX-6, "Removal and Installation"](#) .

NOTE:

It is necessary to disassemble the rear axle to replace the sensor rotor.

2. Pull the sensor rotor of off the axle shaft using Tool and a press.

Tool number : 205-D002 (—)

Installation

1. Install new sensor rotor on axle shaft using a suitable length steel tube and a press. Make sure sensor rotor is fully seated.

CAUTION:

Do not reuse the old sensor rotor.

2. Install axle shaft assembly. Refer to [RAX-6, "Removal and Installation"](#) .

CAUTION:

Do not reuse the axle oil seal. The axle oil seal must be replaced every time the axle shaft assembly is removed from the axle shaft housing.

A
B
C
D
E
G
H
I
J
K
L
M

BRC

ACTUATOR AND ELECTRIC UNIT (ASSEMBLY)

PFP:47660

Removal and Installation

EF5004T1

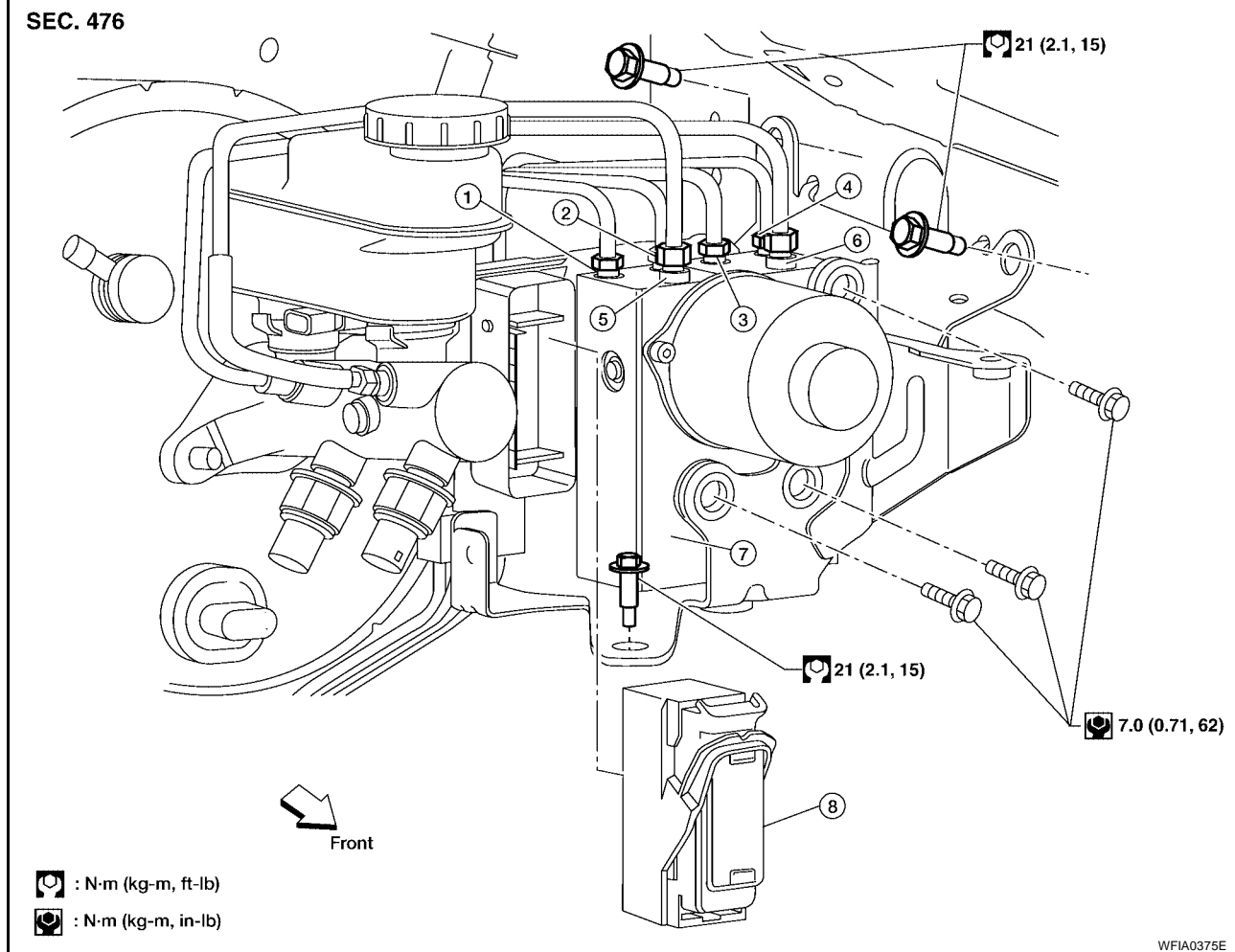

- | | | |
|--|--|--|
| 1. To rear left | 2. To rear right | 3. To front left |
| 4. To front right | 5. From the master cylinder secondary side | 6. From the master cylinder primary side |
| 7. ABS actuator and electric unit (control unit) | 8. Harness connector | |

REMOVAL

1. Disconnect the negative battery terminal.
2. Remove the cowl top extension. Refer to [EI-21, "Removal and Installation"](#).
3. Drain the brake fluid. Refer to [BR-10, "Drain and Refill"](#).
4. Disconnect the actuator harness from the ABS actuator and electric unit (control unit).

CAUTION:

- To remove the brake tubes, use a flare nut wrench to prevent the flare nuts and brake tubes from being damaged.
- Be careful not to splash brake fluid on painted areas.

5. Disconnect the brake tubes.
6. Remove the three bolts and remove the ABS actuator and electric unit (control unit).

INSTALLATION

Installation is in the reverse order of removal.

CAUTION:

To install, use a flare nut wrench (commercial service tool).

- Always tighten brake tubes to specification when installing. Refer to [BR-12, "BRAKE PIPING AND HOSE"](#) .
- Never reuse drained brake fluid.
- After installation of the ABS actuator and electric unit (control unit), perform the following.
 - Refill brake system with new brake fluid. Then bleed the air from the system. Refer to [BR-11, "Bleeding Brake System"](#) .
 - Adjust the steering angle sensor. Refer to [BRC-148, "Adjustment of Steering Angle Sensor Neutral Position"](#) .
 - Calibrate the decel G sensor. Refer to [BRC-148, "Calibration of Yaw Rate/Side/Decel G Sensor"](#) .

A
B
C
D
E

G
H
I
J
K
L
M

BRC

STEERING ANGLE SENSOR

PF2:25554

Removal and Installation

EF500472

NOTE:

The steering angle sensor is an integral part of the spiral cable.
Refer to [SRS-46, "Removal and Installation"](#).

G SENSOR**Removal and Installation****REMOVAL**

1. Remove center console or center seat as required. Refer to [IP-10, "INSTRUMENT PANEL ASSEMBLY"](#) or [SE-91, "FRONT SEAT"](#).

2. Remove yaw rate/side/decel G sensor attaching nuts as shown.

- The location of the sensor is the same for all models.

CAUTION:

- Do not use power tools to remove or install yaw rate/side/decel G sensor.

- Do not drop or strike the yaw rate/side/decel G sensor.

3. Disconnect harness connector and remove the yaw rate/side/decel G sensor.

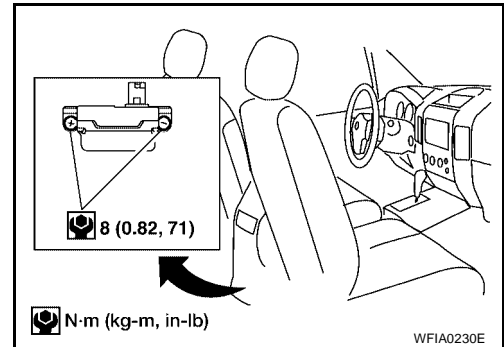
**INSTALLATION**

Installation is in the reverse order of removal.

A

B

C

D

E

BRC

G

H

I

J

K

L

M

