

SECTION **SE**
SEAT

A
B
C
D
E
F
G
H
SE
J
K
L
M

CONTENTS

PRECAUTIONS	3	Control Unit	25
Precautions for Supplemental Restraint System (SRS) "AIR BAG" and "SEAT BELT PRE-TENSIONER"	3	Automatic Drive Positioner Control Unit Harness Connector Terminal Layout	28
Precautions for Work	3	Terminals and Reference Values for Automatic Drive Positioner Control Unit	28
PREPARATION	4	Work Flow	30
Special Service Tool	4	Preliminary Check	30
Commercial Service Tool	4	SETTING CHANGE FUNCTION	30
SQUEAK AND RATTLE TROUBLE DIAGNOSES	5	BCM Power Supply and Ground Circuit Check	30
Work Flow	5	Power Supply and Ground Circuit Check	31
CUSTOMER INTERVIEW	5	CONSULT-II Function (AUTO DRIVE POS.)	32
DUPLICATE THE NOISE AND TEST DRIVE	6	CONSULT-II START PROCEDURE	32
CHECK RELATED SERVICE BULLETINS	6	SELF-DIAGNOSIS RESULTS	33
LOCATE THE NOISE AND IDENTIFY THE ROOT CAUSE	6	DATA MONITOR	34
REPAIR THE CAUSE	6	ACTIVE TEST	35
CONFIRM THE REPAIR	7	CAN Communication Inspection Using CONSULT-II (Self-Diagnosis)	35
Generic Squeak and Rattle Troubleshooting	7	Symptom Chart	35
INSTRUMENT PANEL	7	Sliding Motor Circuit Inspection	37
CENTER CONSOLE	7	Reclining Motor LH Circuit Inspection	38
DOORS	7	Lifting Motor (Front) Circuit Inspection	39
TRUNK	8	Lifting Motor (Rear) Circuit Inspection	41
SUNROOF/HEADLINING	8	Pedal Adjusting Motor Circuit Inspection	42
OVERHEAD CONSOLE (FRONT AND REAR).....	8	Mirror Motor LH Circuit Check	43
SEATS	8	Mirror Motor RH Circuit Check	45
UNDERHOOD	8	Sliding Sensor Circuit Inspection	46
Diagnostic Worksheet	9	Reclining Sensor Circuit Inspection	47
AUTOMATIC DRIVE POSITIONER	11	Lifting Sensor (Front) Circuit Inspection	48
Component Parts And Harness Connector Location	11	Lifting Sensor (Rear) Circuit Inspection	49
System Description	11	Pedal Adjusting Sensor Circuit Inspection	50
FAIL- SAFE MODE	12	Mirror Sensor LH Circuit Check	51
CANCEL OF FAIL-SAFE MODE	12	Mirror Sensor RH Circuit Check	53
CAN Communication System Description	12	Sliding Switch Circuit Inspection	55
Schematic	13	Reclining Switch Inspection	57
Wiring Diagram — AUT/DP —	15	Lifting Switch (Front) Circuit Inspection	58
Terminals and Reference Values for BCM	25	Lifting Switch (Rear) Circuit Inspection	60
Driver Seat Control Unit Harness Connector Terminal Layout	25	Power Seat Switch Ground Inspection	61
Terminals and Reference Values for Driver Seat Control Unit	25	Pedal Adjusting Switch Circuit Inspection	62
		Door Mirror Remote Control Switch (Changeover Switch) Circuit Check	64

Door Mirror Remote Control Switch (Mirror Switch) Circuit Check	65	HEATED SEAT	82
Door Mirror Remote Control Switch Ground Circuit Inspection	67	Description	82
Seat Memory Switch Circuit Inspection	67	Wiring Diagram — HSEAT —	83
Seat Memory Indicator Lamp Circuit Inspection	69	FRONT SEAT	85
Door Mirror Sensor Power Supply and Ground Cir- cuit inspection	70	Removal and Installation	85
A/T Device (Park Position Switch) Circuit Inspection (Floor Shift)	71	REMOVAL	90
A/T Device (Park Position Switch) Circuit Inspection (Column Shift)	72	INSTALLATION	90
Front Door Switch LH Circuit Inspection (King Cab)..	73	Disassembly and Assembly	90
Front Door Switch LH Circuit Inspection (Crew Cab)..	74	SEATBACK TRIM AND PAD	90
UART Communication Line Circuit Inspection	75	REMOVAL OF SEATBACK ASSEMBLY	91
Removal and Installation	77	INSTALLATION OF SEATBACK ASSEMBLY	92
POWER SEAT	78	SEAT CUSHION TRIM AND PAD	92
Schematic	78	REAR SEAT	94
Wiring Diagram — SEAT —	79	Removal and Installation	94
		REMOVAL	94
		INSTALLATION	94
		Disassembly and Assembly	95

PRECAUTIONS

PRECAUTIONS

PFP:00001

Precautions for Supplemental Restraint System (SRS) “AIR BAG” and “SEAT BELT PRE-TENSIONER”

EIS004F4

The Supplemental Restraint System such as “AIR BAG” and “SEAT BELT PRE-TENSIONER”, used along with a front seat belt, helps to reduce the risk or severity of injury to the driver and front passenger for certain types of collision. This system includes seat belt switch inputs and dual stage front air bag modules. The SRS system uses the seat belt switches to determine the front air bag deployment, and may only deploy one front air bag, depending on the severity of a collision and whether the front occupants are belted or unbelted. Information necessary to service the system safely is included in the SRS and SB section of this Service Manual.

WARNING:

- To avoid rendering the SRS inoperative, which could increase the risk of personal injury or death in the event of a collision which would result in air bag inflation, all maintenance must be performed by an authorized NISSAN/INFINITI dealer.
- Improper maintenance, including incorrect removal and installation of the SRS, can lead to personal injury caused by unintentional activation of the system. For removal of Spiral Cable and Air Bag Module, see the SRS section.
- Do not use electrical test equipment on any circuit related to the SRS unless instructed to in this Service Manual. SRS wiring harnesses can be identified by yellow and/or orange harnesses or harness connectors.

Precautions for Work

EIS004F5

- When removing or disassembling each component, be careful not to damage or deform it. If a component may be subject to interference, be sure to protect it with a shop cloth.
- When removing (disengaging) components with a screwdriver or similar tool, be sure to wrap the component with a shop cloth or vinyl tape to protect it.
- Protect the removed parts with a shop cloth and keep them.
- Replace a deformed or damaged clip.
- If a part is specified as a non-reusable part, always replace it with new one.
- Be sure to tighten bolts and nuts securely to the specified torque.
- After re-installation is completed, be sure to check that each part works normally.
- Follow the steps below to clean components.
 - Water soluble foul: Dip a soft cloth into lukewarm water, and wring the water out of the cloth to wipe the fouled area.
Then rub with a soft and dry cloth.
 - Oily foul: Dip a soft cloth into lukewarm water with mild detergent (concentration: within 2 to 3%), and wipe the fouled area.
Then dip a cloth into fresh water, and wring the water out of the cloth to wipe the detergent off. Then rub with a soft and dry cloth.
- Do not use organic solvent such as thinner, benzene, alcohol, or gasoline.
- For genuine leather seats, use a genuine leather seat cleaner.

PREPARATION

PREPARATION

PFP:00002

Special Service Tool

EIS004F6

The actual shapes of Kent-Moore tools may differ from those of special service tools illustrated here.

Tool number (Kent-Moore No.) Tool name	Description
— (J-39570) Chassis ear	Locating the noise
— (J-43980) NISSAN Squeak and Rattle Kit	Repairing the cause of noise

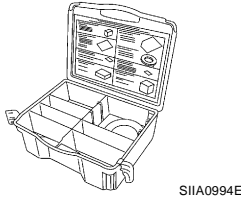
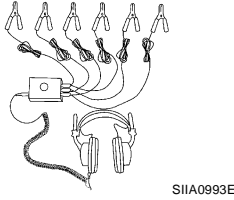

Commercial Service Tool

EIS004F7

(Kent-Moore No.) Tool name	Description
(J-39565) Engine ear	Locating the noise

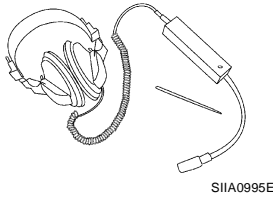

SQUEAK AND RATTLE TROUBLE DIAGNOSES

SQUEAK AND RATTLE TROUBLE DIAGNOSES

PF0:0000

Work Flow

EIS004F8

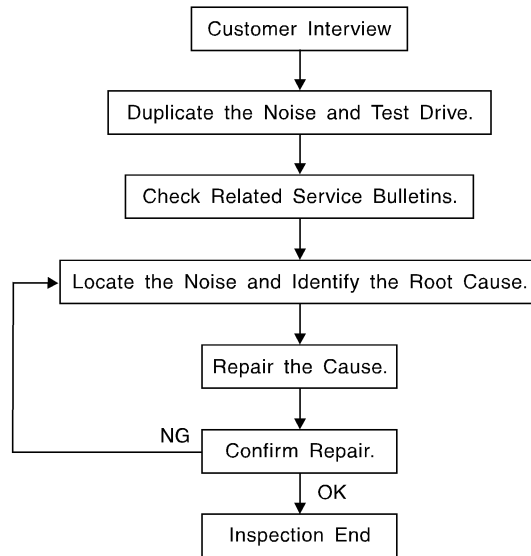

SBT842

CUSTOMER INTERVIEW

Interview the customer if possible, to determine the conditions that exist when the noise occurs. Use the Diagnostic Worksheet during the interview to document the facts and conditions when the noise occurs and any customer's comments; refer to [SE-9, "Diagnostic Worksheet"](#). This information is necessary to duplicate the conditions that exist when the noise occurs.

- The customer may not be able to provide a detailed description or the location of the noise. Attempt to obtain all the facts and conditions that exist when the noise occurs (or does not occur).
- If there is more than one noise in the vehicle, be sure to diagnose and repair the noise that the customer is concerned about. This can be accomplished by test driving the vehicle with the customer.
- After identifying the type of noise, isolate the noise in terms of its characteristics. The noise characteristics are provided so the customer, service adviser and technician are all speaking the same language when defining the noise.
- Squeak —(Like tennis shoes on a clean floor)
Squeak characteristics include the light contact/fast movement/brought on by road conditions/hard surfaces = higher pitch noise/softer surfaces = lower pitch noises/edge to surface = chirping.
- Creak—(Like walking on an old wooden floor)
Creak characteristics include firm contact/slow movement/twisting with a rotational movement/pitch dependent on materials/often brought on by activity.
- Rattle—(Like shaking a baby rattle)
Rattle characteristics include the fast repeated contact/vibration or similar movement/loose parts/missing clip or fastener/incorrect clearance.
- Knock —(Like a knock on a door)
Knock characteristics include hollow sounding/sometimes repeating/often brought on by driver action.
- Tick—(Like a clock second hand)
Tick characteristics include gentle contacting of light materials/loose components/can be caused by driver action or road conditions.
- Thump—(Heavy, muffled knock noise)
Thump characteristics include softer knock/dead sound often brought on by activity.
- Buzz—(Like a bumble bee)
Buzz characteristics include high frequency rattle/firm contact.
- Often the degree of acceptable noise level will vary depending upon the person. A noise that you may judge as acceptable may be very irritating to the customer.
- Weather conditions, especially humidity and temperature, may have a great effect on noise level.

SQUEAK AND RATTLE TROUBLE DIAGNOSES

DUPLICATE THE NOISE AND TEST DRIVE

If possible, drive the vehicle with the customer until the noise is duplicated. Note any additional information on the Diagnostic Worksheet regarding the conditions or location of the noise. This information can be used to duplicate the same conditions when you confirm the repair.

If the noise can be duplicated easily during the test drive, to help identify the source of the noise, try to duplicate the noise with the vehicle stopped by doing one or all of the following:

- 1) Close a door.
 - 2) Tap or push/pull around the area where the noise appears to be coming from.
 - 3) Rev the engine.
 - 4) Use a floor jack to recreate vehicle "twist".
 - 5) At idle, apply engine load (electrical load, half-clutch on M/T model, drive position on A/T model).
 - 6) Raise the vehicle on a hoist and hit a tire with a rubber hammer.
- Drive the vehicle and attempt to duplicate the conditions the customer states exist when the noise occurs.
 - If it is difficult to duplicate the noise, drive the vehicle slowly on an undulating or rough road to stress the vehicle body.

CHECK RELATED SERVICE BULLETINS

After verifying the customer concern or symptom, check ASIST for Technical Service Bulletins (TSBs) related to that concern or symptom.

If a TSB relates to the symptom, follow the procedure to repair the noise.

LOCATE THE NOISE AND IDENTIFY THE ROOT CAUSE

1. Narrow down the noise to a general area. To help pinpoint the source of the noise, use a listening tool (Chassis Ear: J-39570, Engine Ear: J-39565 and mechanic's stethoscope).
2. Narrow down the noise to a more specific area and identify the cause of the noise by:
 - removing the components in the area that you suspect the noise is coming from. Do not use too much force when removing clips and fasteners, otherwise clips and fasteners can be broken or lost during the repair, resulting in the creation of new noise.
 - tapping or pushing/pulling the component that you suspect is causing the noise. Do not tap or push/pull the component with excessive force, otherwise the noise will be eliminated only temporarily.
 - feeling for a vibration with your hand by touching the component(s) that you suspect is (are) causing the noise.
 - placing a piece of paper between components that you suspect are causing the noise.
 - looking for loose components and contact marks.
Refer to [SE-7, "Generic Squeak and Rattle Troubleshooting"](#) .

REPAIR THE CAUSE

- If the cause is a loose component, tighten the component securely.
- If the cause is insufficient clearance between components:
 - separate components by repositioning or loosening and retightening the component, if possible.
 - insulate components with a suitable insulator such as urethane pads, foam blocks, felt cloth tape or urethane tape. A NISSAN Squeak and Rattle Kit (J-43980) is available through your authorized NISSAN Parts Department.

CAUTION:

Do not use excessive force as many components are constructed of plastic and may be damaged.

Always check with the Parts Department for the latest parts information.

The following materials are contained in the NISSAN Squeak and Rattle Kit (J-43980). Each item can be ordered separately as needed.

URETHANE PADS [1.5 mm (0.059 in) thick]

Insulates connectors, harness, etc.

76268-9E005: 100×135 mm (3.94×5.31 in)/76884-71L01: 60×85 mm (2.36×3.35 in)/76884-71L02: 15×25 mm (0.59×0.98 in)

INSULATOR (Foam blocks)

Insulates components from contact. Can be used to fill space behind a panel.

73982-9E000: 45 mm (1.77 in) thick, 50×50 mm (1.97×1.97 in)/73982-50Y00: 10 mm (0.39 in) thick, 50×50 mm (1.97×1.97 in)

INSULATOR (Light foam block)

SQUEAK AND RATTLE TROUBLE DIAGNOSES

80845-71L00: 30 mm (1.18 in) thick, 30×50 mm (1.18×1.97 in)

FELT CLOTH TAPE

Used to insulate where movement does not occur. Ideal for instrument panel applications.

68370-4B000: 15×25 mm (0.59×0.98 in) pad/68239-13E00: 5 mm (0.20 in) wide tape roll. The following materials not found in the kit can also be used to repair squeaks and rattles.

UHMW (TEFLON) TAPE

Insulates where slight movement is present. Ideal for instrument panel applications.

SILICONE GREASE

Used instead of UHMW tape that will be visible or not fit.

Note: Will only last a few months.

SILICONE SPRAY

Use when grease cannot be applied.

DUCT TAPE

Use to eliminate movement.

CONFIRM THE REPAIR

Confirm that the cause of a noise is repaired by test driving the vehicle. Operate the vehicle under the same conditions as when the noise originally occurred. Refer to the notes on the Diagnostic Worksheet.

Generic Squeak and Rattle Troubleshooting

EIS004F9

Refer to Table of Contents for specific component removal and installation information.

INSTRUMENT PANEL

Most incidents are caused by contact and movement between:

1. The cluster lid A and instrument panel
2. Acrylic lens and combination meter housing
3. Instrument panel to front pillar garnish
4. Instrument panel to windshield
5. Instrument panel mounting pins
6. Wiring harnesses behind the combination meter
7. A/C defroster duct and duct joint

These incidents can usually be located by tapping or moving the components to duplicate the noise or by pressing on the components while driving to stop the noise. Most of these incidents can be repaired by applying felt cloth tape or silicone spray (in hard to reach areas). Urethane pads can be used to insulate wiring harness.

CAUTION:

Do not use silicone spray to isolate a squeak or rattle. If you saturate the area with silicone, you will not be able to recheck the repair.

CENTER CONSOLE

Components to pay attention to include:

1. Shifter assembly cover to finisher
2. A/C control unit and cluster lid C
3. Wiring harnesses behind audio and A/C control unit

The instrument panel repair and isolation procedures also apply to the center console.

DOORS

Pay attention to the:

1. Finisher and inner panel making a slapping noise
2. Inside handle escutcheon to door finisher
3. Wiring harnesses tapping
4. Door striker out of alignment causing a popping noise on starts and stops

Tapping or moving the components or pressing on them while driving to duplicate the conditions can isolate many of these incidents. You can usually insulate the areas with felt cloth tape or insulator foam blocks from the NISSAN Squeak and Rattle Kit (J-43980) to repair the noise.

SQUEAK AND RATTLE TROUBLE DIAGNOSES

TRUNK

Trunk noises are often caused by a loose jack or loose items put into the trunk by the owner. In addition look for:

1. Trunk lid bumpers out of adjustment
2. Trunk lid striker out of adjustment
3. The trunk lid torsion bars knocking together
4. A loose license plate or bracket

Most of these incidents can be repaired by adjusting, securing or insulating the item(s) or component(s) causing the noise.

SUNROOF/HEADLINING

Noises in the sunroof/headlining area can often be traced to one of the following:

1. Sunroof lid, rail, linkage or seals making a rattle or light knocking noise
2. Sun visor shaft shaking in the holder
3. Front or rear windshield touching headliner and squeaking

Again, pressing on the components to stop the noise while duplicating the conditions can isolate most of these incidents. Repairs usually consist of insulating with felt cloth tape.

OVERHEAD CONSOLE (FRONT AND REAR)

Overhead console noises are often caused by the console panel clips not being engaged correctly. Most of these incidents are repaired by pushing up on the console at the clip locations until the clips engage.

In addition look for:

1. Loose harness or harness connectors.
2. Front console map/reading lamp lense loose.
3. Loose screws at console attachment points.

SEATS

When isolating seat noise it's important to note the position the seat is in and the load placed on the seat when the noise is present. These conditions should be duplicated when verifying and isolating the cause of the noise.

Cause of seat noise include:

1. Headrest rods and holder
2. A squeak between the seat pad cushion and frame
3. The rear seatback lock and bracket

These noises can be isolated by moving or pressing on the suspected components while duplicating the conditions under which the noise occurs. Most of these incidents can be repaired by repositioning the component or applying urethane tape to the contact area.

UNDERHOOD

Some interior noise may be caused by components under the hood or on the engine wall. The noise is then transmitted into the passenger compartment.

Causes of transmitted underhood noise include:

1. Any component mounted to the engine wall
2. Components that pass through the engine wall
3. Engine wall mounts and connectors
4. Loose radiator mounting pins
5. Hood bumpers out of adjustment
6. Hood striker out of adjustment

These noises can be difficult to isolate since they cannot be reached from the interior of the vehicle. The best method is to secure, move or insulate one component at a time and test drive the vehicle. Also, engine RPM or load can be changed to isolate the noise. Repairs can usually be made by moving, adjusting, securing, or insulating the component causing the noise.

SQUEAK AND RATTLE TROUBLE DIAGNOSES

EIS004FA

Diagnostic Worksheet

Dear Customer:

We are concerned about your satisfaction with your vehicle. Repairing a squeak or rattle sometimes can be very difficult. To help us fix your vehicle right the first time, please take a moment to note the area of the vehicle where the squeak or rattle occurs and under what conditions. You may be asked to take a test drive with a service advisor or technician to ensure we confirm the noise you are hearing.

SQUEAK & RATTLE DIAGNOSTIC WORKSHEET

I. WHERE DOES THE NOISE COME FROM? (circle the area of the vehicle)

The illustrations are for reference only, and may not reflect the actual configuration of your vehicle.

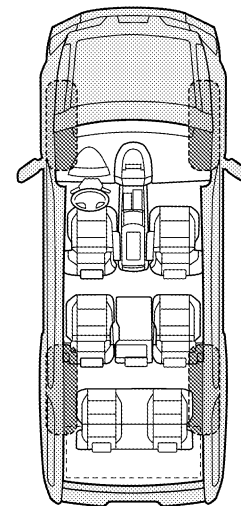
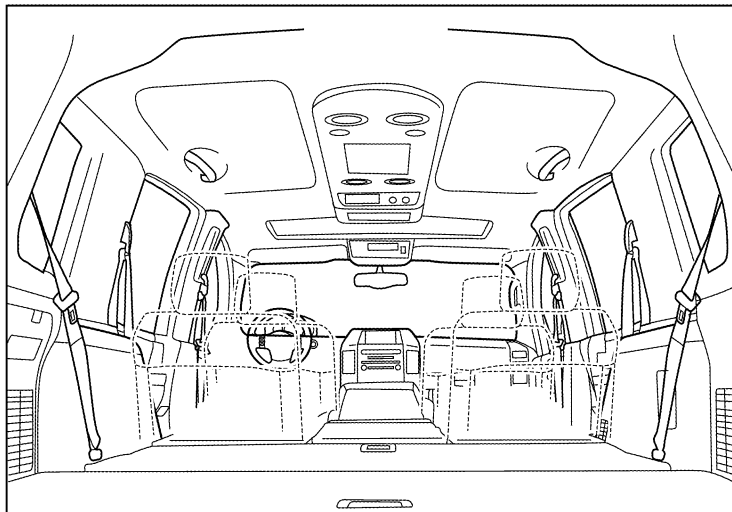
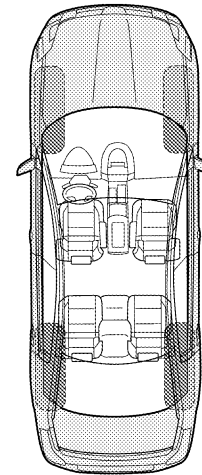
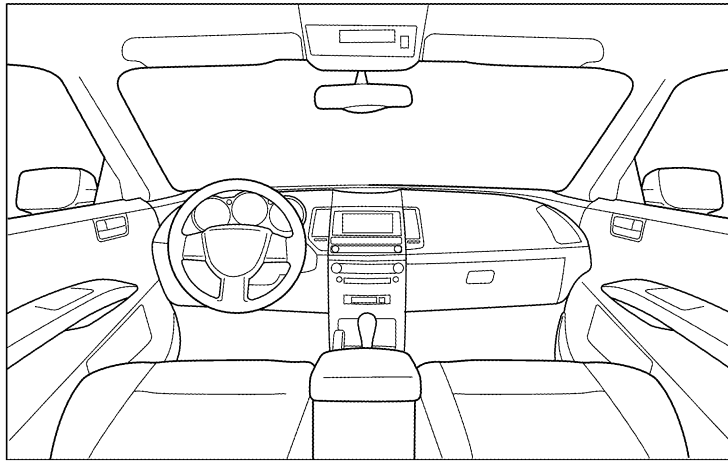

Continue to page 2 of the worksheet and briefly describe the location of the noise or rattle. In addition, please indicate the conditions which are present when the noise occurs.

A
B
C
D
E
F
G
H
SE
J
K
L
M

SQUEAK AND RATTLE TROUBLE DIAGNOSES

SQUEAK & RATTLE DIAGNOSTIC WORKSHEET - page 2

Briefly describe the location where the noise occurs:

II. WHEN DOES IT OCCUR? (please check the boxes that apply)

- | | |
|---|--|
| <input type="checkbox"/> Anytime | <input type="checkbox"/> After sitting out in the rain |
| <input type="checkbox"/> 1st time in the morning | <input type="checkbox"/> When it is raining or wet |
| <input type="checkbox"/> Only when it is cold outside | <input type="checkbox"/> Dry or dusty conditions |
| <input type="checkbox"/> Only when it is hot outside | <input type="checkbox"/> Other: |

III. WHEN DRIVING:

- Through driveways
- Over rough roads
- Over speed bumps
- Only about ____ mph
- On acceleration
- Coming to a stop
- On turns: left, right or either (circle)
- With passengers or cargo
- Other: _____
- After driving ____ miles or ____ minutes

IV. WHAT TYPE OF NOISE

- Squeak (like tennis shoes on a clean floor)
- Creak (like walking on an old wooden floor)
- Rattle (like shaking a baby rattle)
- Knock (like a knock at the door)
- Tick (like a clock second hand)
- Thump (heavy muffled knock noise)
- Buzz (like a bumble bee)

TO BE COMPLETED BY DEALERSHIP PERSONNEL

Test Drive Notes:

	YES	NO	Initials of person performing
Vehicle test driven with customer	<input type="checkbox"/>	<input type="checkbox"/>	_____
- Noise verified on test drive	<input type="checkbox"/>	<input type="checkbox"/>	_____
- Noise source located and repaired	<input type="checkbox"/>	<input type="checkbox"/>	_____
- Follow up test drive performed to confirm repair	<input type="checkbox"/>	<input type="checkbox"/>	_____

LAI A0071E

AUTOMATIC DRIVE POSITIONER

PF2:28491

EIS004FB

AUTOMATIC DRIVE POSITIONER

Component Parts And Harness Connector Location

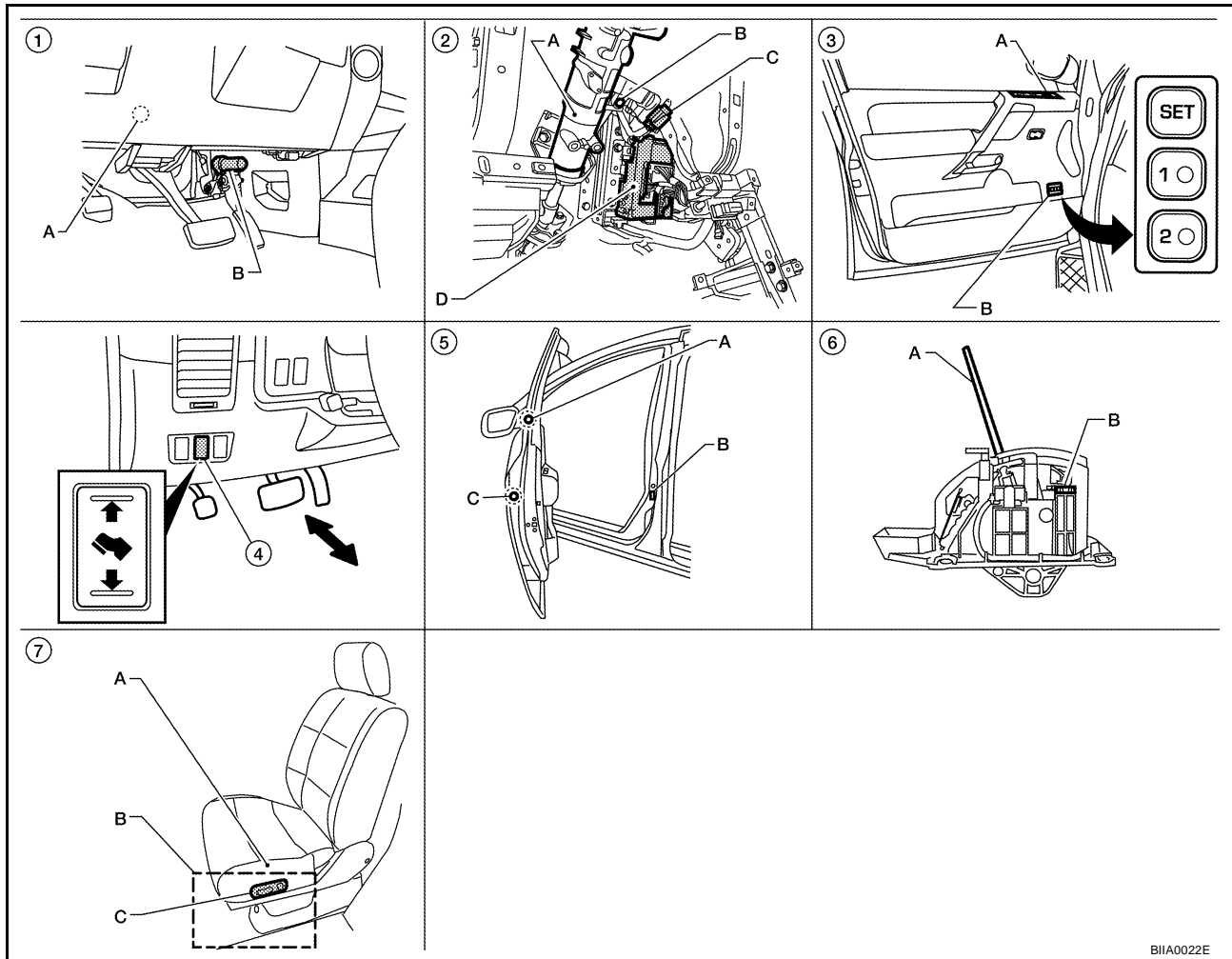

- | | | |
|---|--|---|
| <p>1. A. Automatic drive positioner control unit M33, M34
B. Pedal adjusting motor E109, E110</p> | <p>2. A. Steering column
B. A/T device (park position switch) (column shift)
C. Key switch and key lock solenoid M27 (floor shift)
D. BCM M18, M19, M20 (view with instrument panel removed)</p> | <p>3. A. Door mirror remote control switch D10
B. Seat memory switch D5</p> |
| <p>4. Pedal adjusting switch M96</p> | <p>5. A. Door mirror LH D4, RH D107
B. Front door switch LH B8
C. Front door lock assembly LH (key cylinder switch)</p> | <p>6. A. A/T selector lever
B. A/T device (park position switch) M203 (floor shift)</p> |
| <p>7. A. Sliding motor LH P4 (driver seat view), reclining motor LH P5, lifting motor (front) P6, lifting motor (rear) P7
B. Driver seat control unit P2, P3
C. Power seat switch LH P8</p> | | |

B11A0022E

System Description

EIS004FE

- Refer to Owner's Manual for Automatic Drive Positioner system operating instructions.
- The settings (ON/OFF) of the automatic sliding seat (entry/exiting operation) at entry/exit can be changed as desired, using the display unit in the center of the instrument panel. The set content is transmitted by CAN communication, from display unit (without NAVI) or display control unit (with NAVI) to driver seat control unit.
- Using CONSULT-II, the seat slide amount at entry/exit setting can be changed.

AUTOMATIC DRIVE POSITIONER

Function	Description
Memory operation	The front seat LH, pedal (accelerator, brake) and door mirror move to the stored driving position by pushing seat memory switch (1 or 2).
Entry/exiting function	Exiting operation At exit, the seat moves backward. (exiting position)
	Entry operation At entry, the seat returns from exiting position to the previous driving position before the exiting operation.
Keyfob interlock operation	Perform memory operation, turnout operation and return operation by pressing keyfob unlock button.

NOTE:

- Disconnecting the battery erases the stored memory.
- After connecting the battery, insert the key into the ignition cylinder and turn the front door switch LH ON (open)→OFF (close)→ON (open), the Entry/Exiting function becomes possible.
- After Exiting operation is carried out, return operation can be operated.

Auto operation temporary stop conditions.	When ignition switch is turned to START during seat memory switch operation and return operation, seat memory switch operation and return operation is stopped.
Auto operation stop conditions.	<ul style="list-style-type: none"> ● When the vehicle speed becomes 7 km/h (4 MPH) or higher (memory switch operation and entry operation). ● When the setting switch, seat memory switch 1 or 2 are pressed. ● When A/T selector lever is in any position other than P. ● When the door mirror remote control switch is operated (when ignition switch turned to ON). ● When power seat switch turned ON. ● When pedal adjusting switch turned ON. ● When front seat sliding entry/exiting setting is OFF (entry/exiting operation).

NOTE:

During automatic operation, if the ignition switch is turned ON→START, the automatic operation is suspended. When the ignition switch returns to ON, it resumes.

FAIL- SAFE MODE

When any manual and automatic operations are not performed, if any motor operations of seats or pedals are detected for T2 or more, status is judged "Output error".

OPERATED PORTION	T2
Seat sliding	Approx. 0.1 sec.
Seat reclining	Same as above
Seat lifting (Front)	Same as above
Seat lifting (Rear)	Same as above
Pedal adjust	Same as above

CANCEL OF FAIL-SAFE MODE

The mode is cancelled when the A/T selector lever is shifted to P position from any other position.

NOTE:

The front seat LH position and pedal adjustment functions (see the following table) operate simultaneously in the order of priority.

Priority	Function	Priority	Function
1	Seat sliding, (door mirror LH/RH)*	4	Seat lifter-FR
2	Pedal	5	Seat lifter-RR
3	Seat reclining		

*: In conjunction with sliding the seat, the door mirrors are positioned.

CAN Communication System Description

EIS004FF

Refer to [LAN-2, "SYSTEM DESCRIPTION"](#) .

AUTOMATIC DRIVE POSITIONER

Schematic

EIS004FG

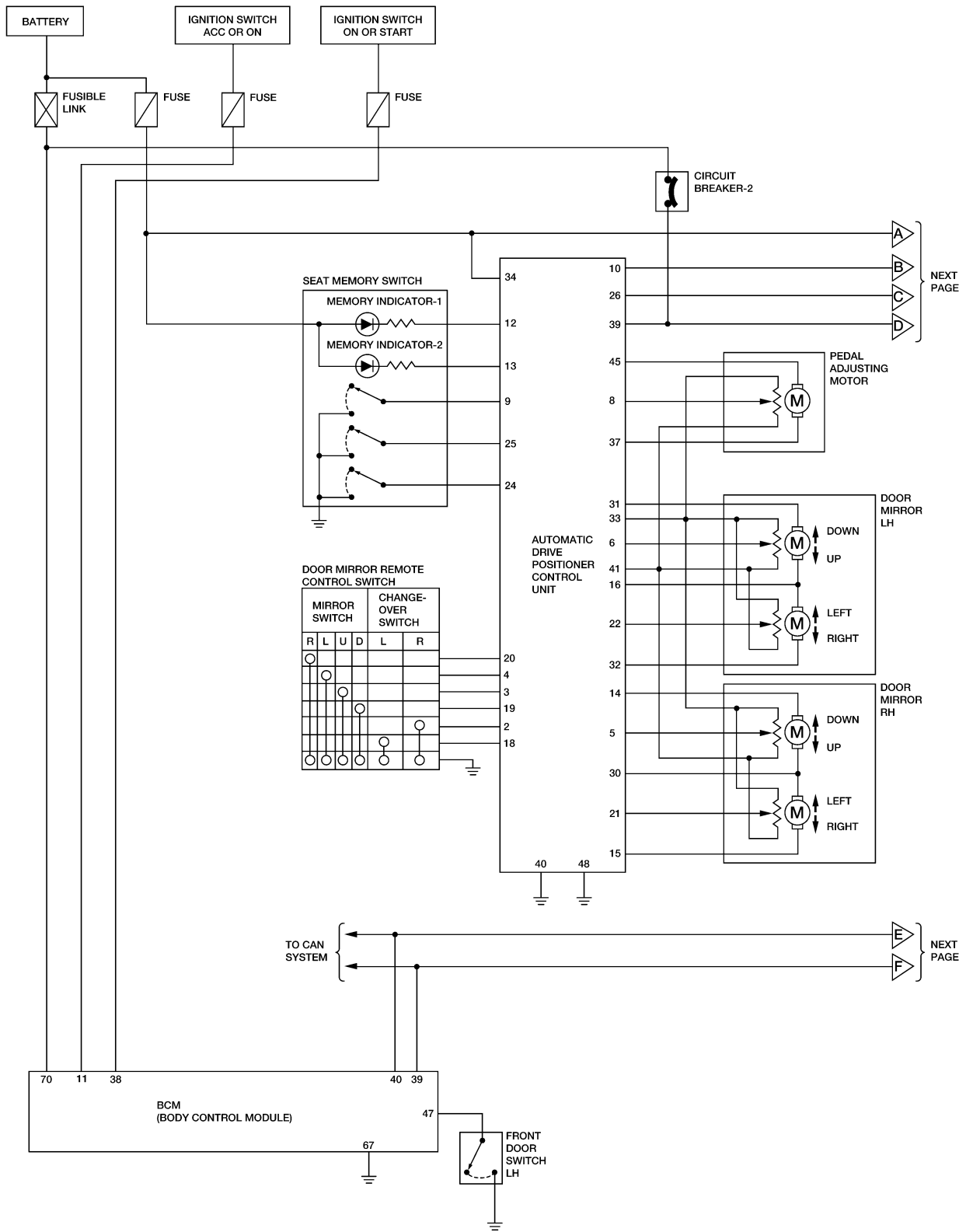

A
B
C
D
E
F
G
H
SE
J
K
L
M

WIWA2074E

AUTOMATIC DRIVE POSITIONER

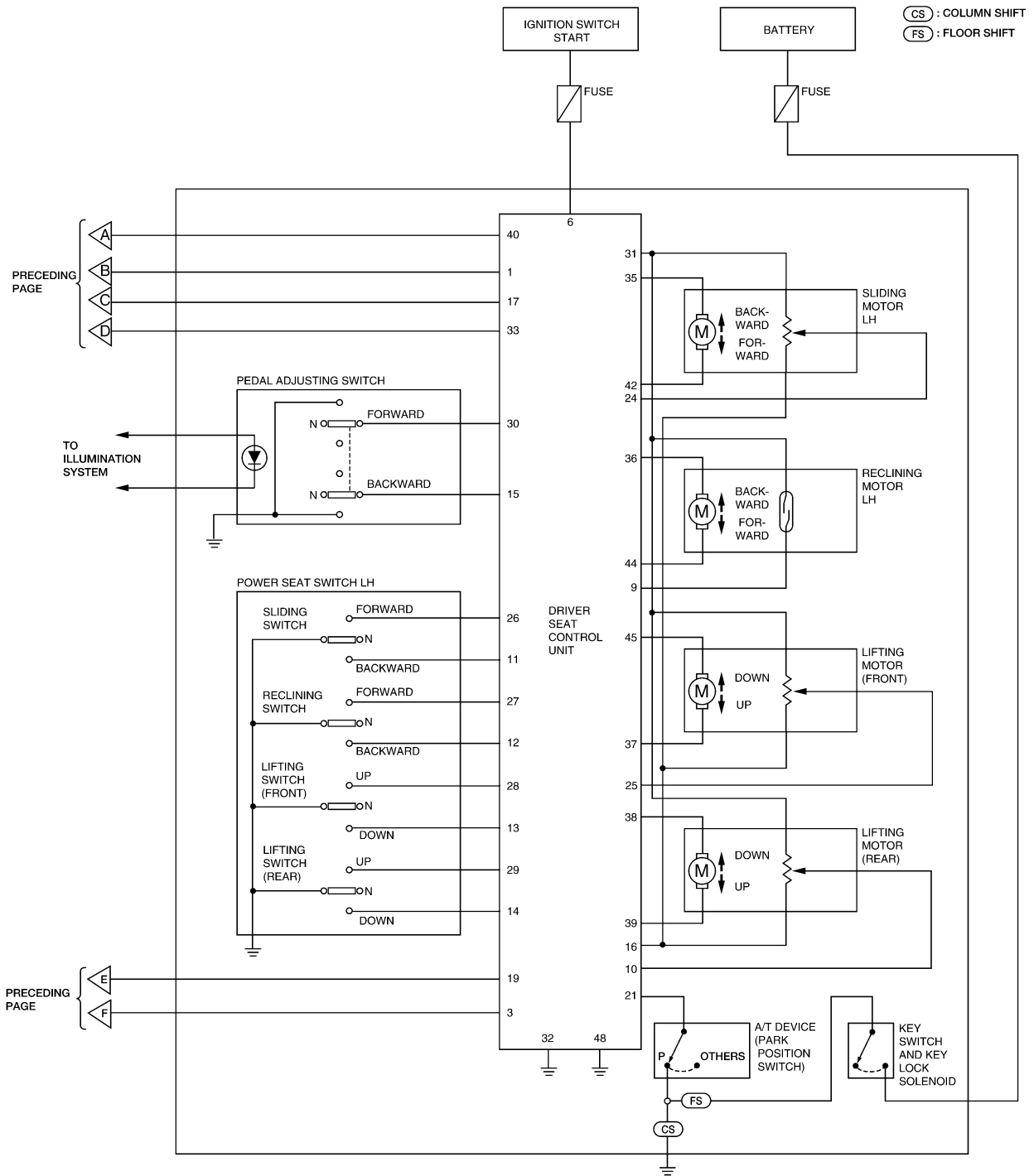

WIWA1365E

AUTOMATIC DRIVE POSITIONER

Wiring Diagram — AUT/DP —

EIS004FH

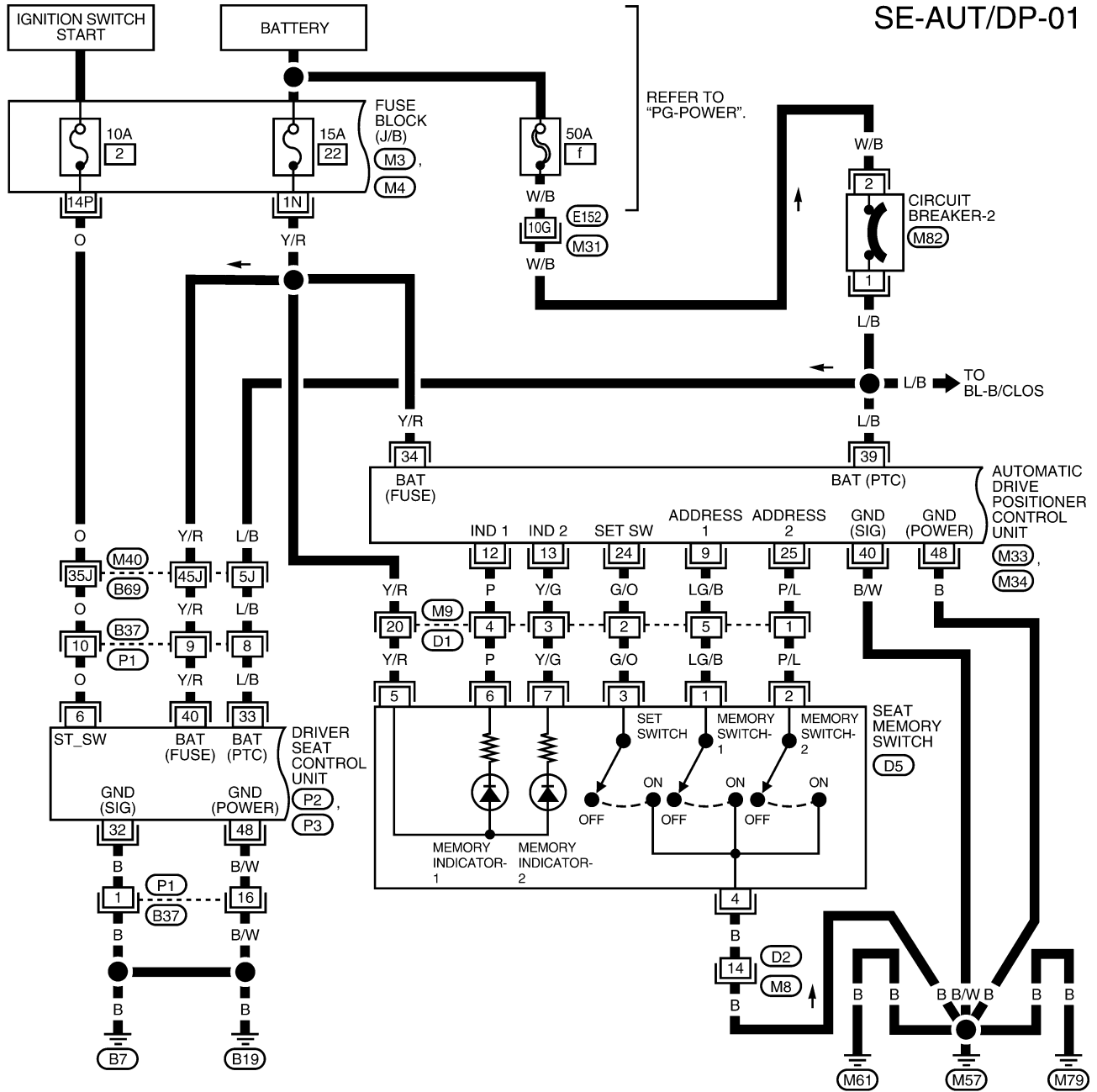

A
B
C
D
E
F
G
H
SE
J
K
L
M

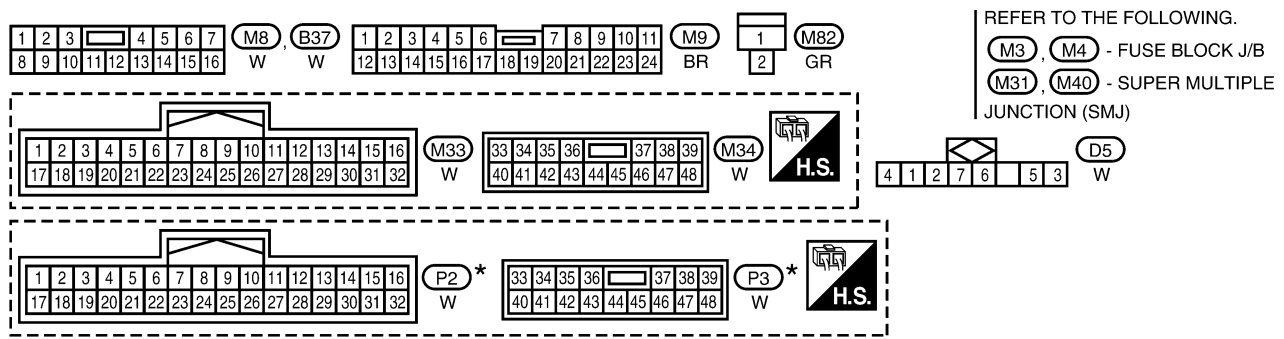

*: THIS CONNECTOR IS NOT SHOWN IN "HARNESS LAYOUT" OF PG SECTION.

WIIWA1366E

AUTOMATIC DRIVE POSITIONER

SE-AUT/DP-02

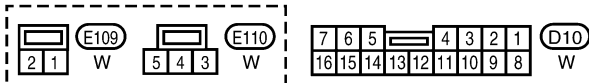
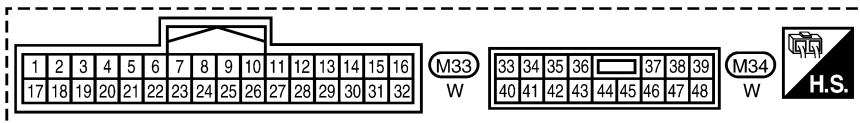
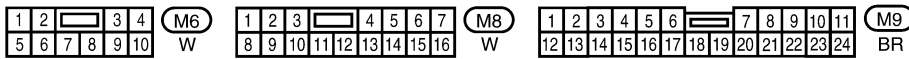
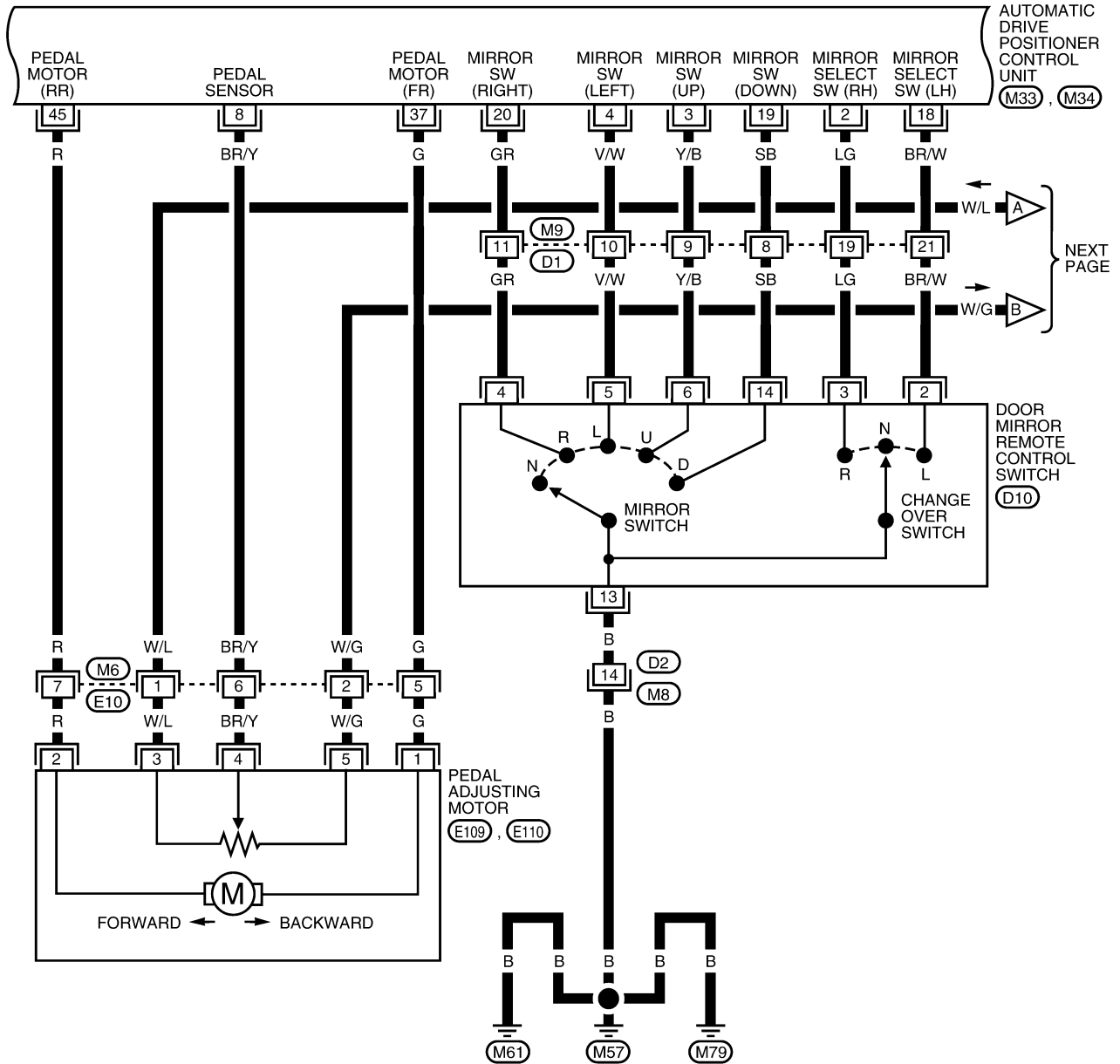

WIWA2075E

AUTOMATIC DRIVE POSITIONER

SE-AUT/DP-03

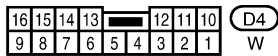
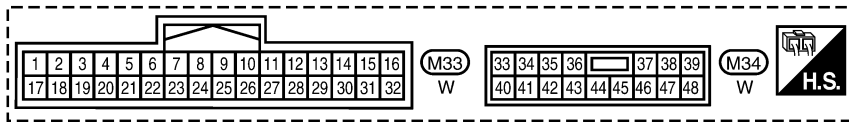
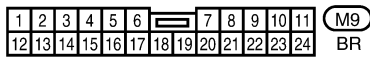
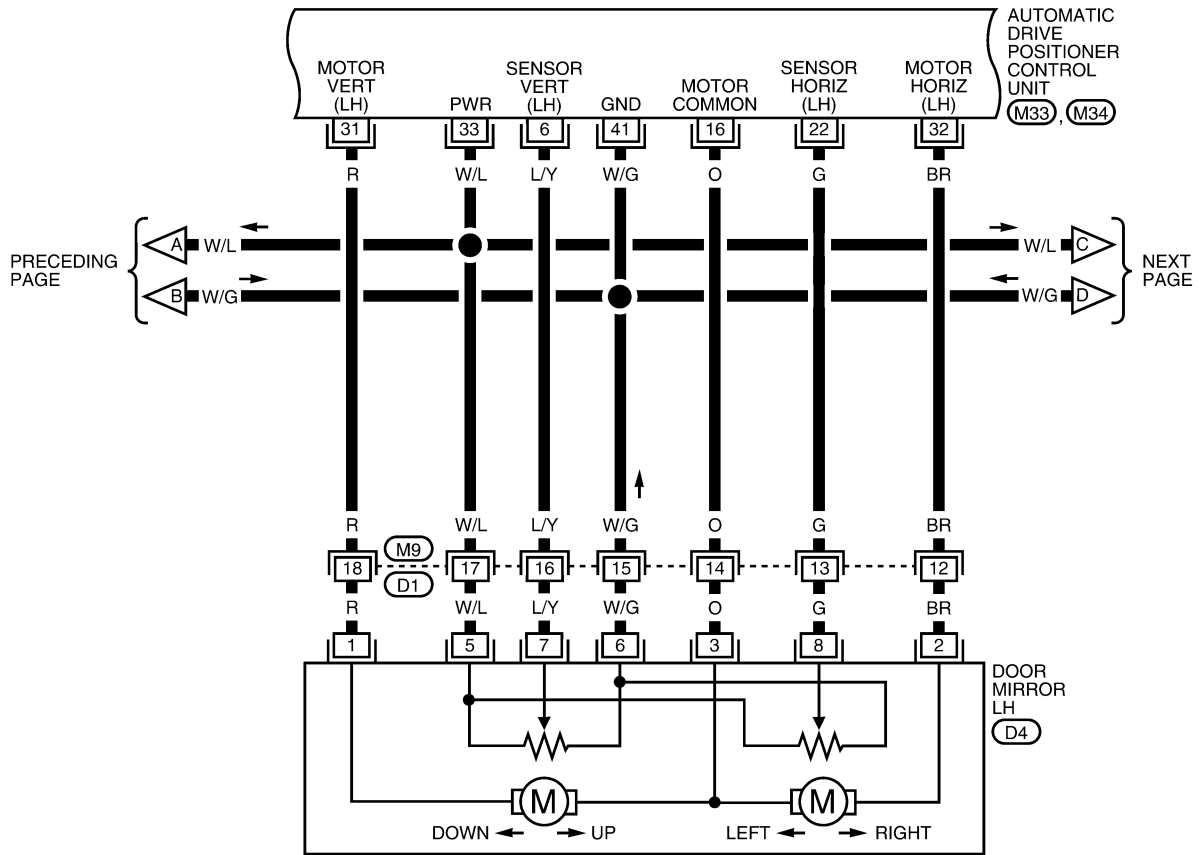

W1WA0579E

AUTOMATIC DRIVE POSITIONER

SE-AUT/DP-04

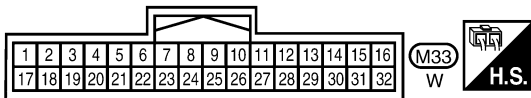
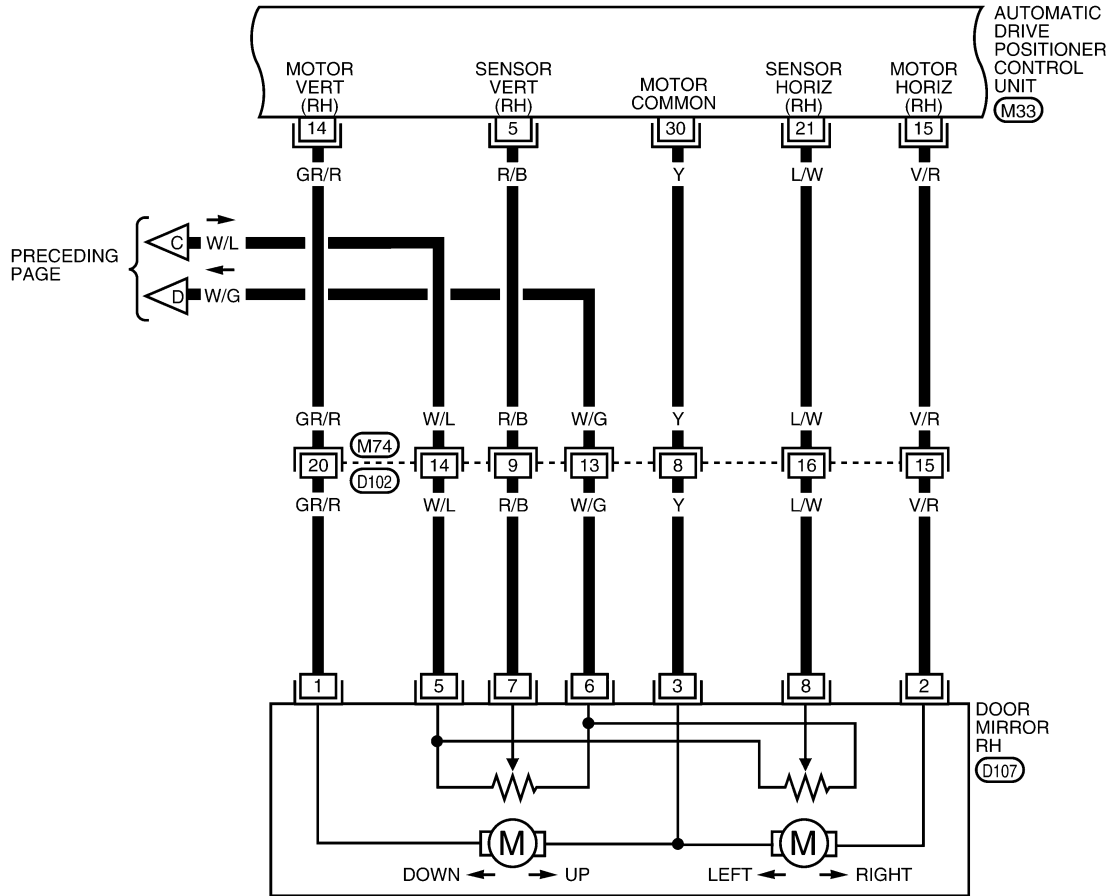

WIWA0220E

AUTOMATIC DRIVE POSITIONER

WITH FLOOR SHIFT

SE-AUT/DP-05

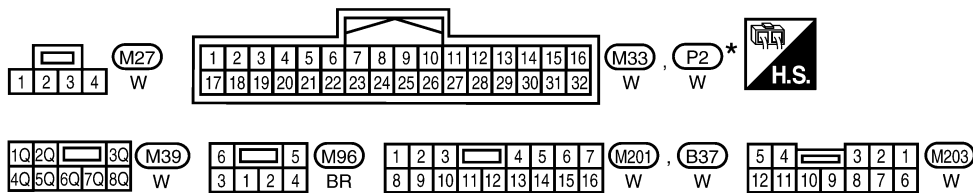
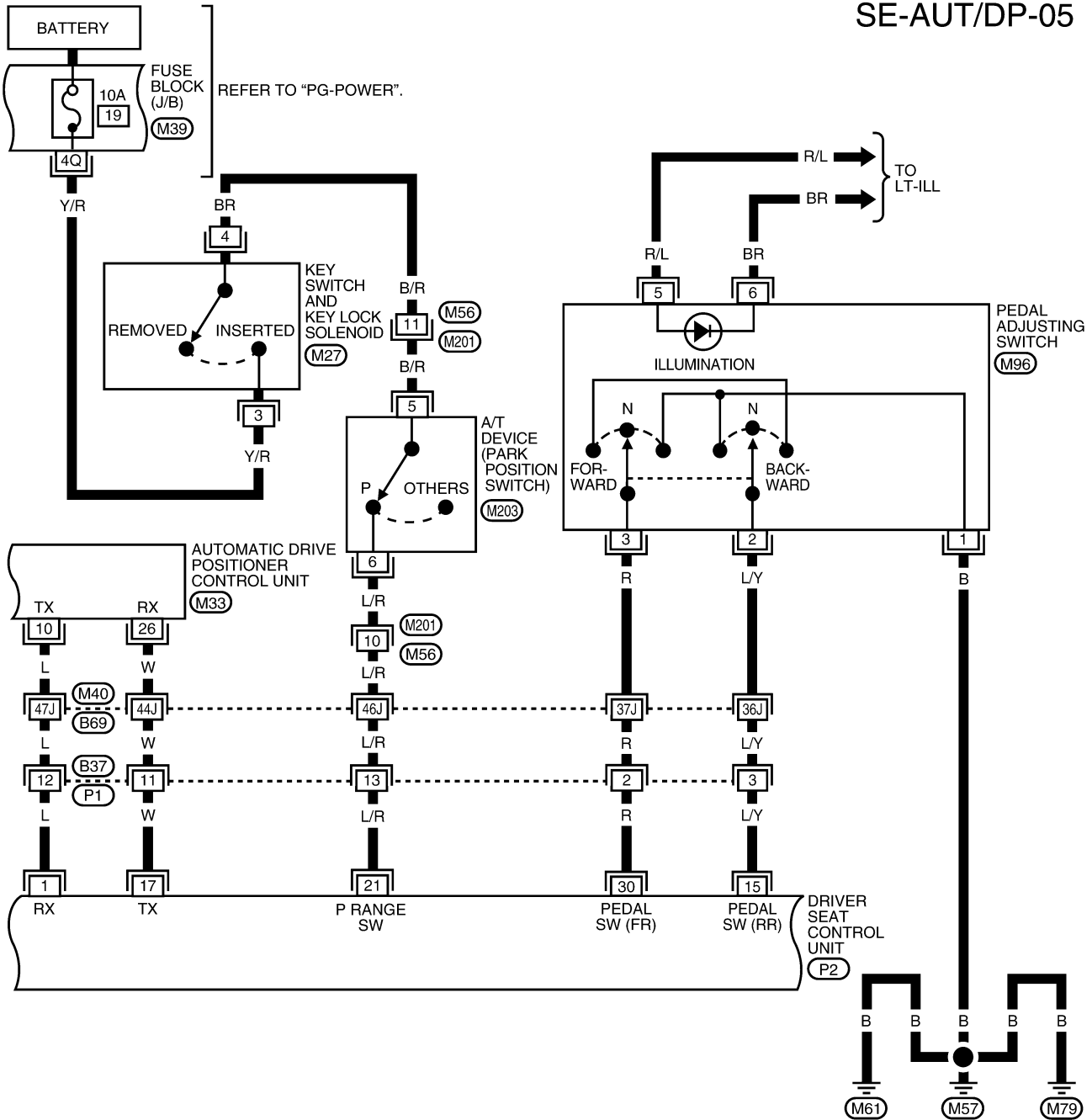

REFER TO THE FOLLOWING.
 (M40) - SUPER MULTIPLE JUNCTION (SMJ)

*: THIS CONNECTOR IS NOT SHOWN IN "HARNESS LAYOUT" OF PG SECTION.

WIWA1368E

AUTOMATIC DRIVE POSITIONER

WITH COLUMN SHIFT

SE-AUT/DP-06

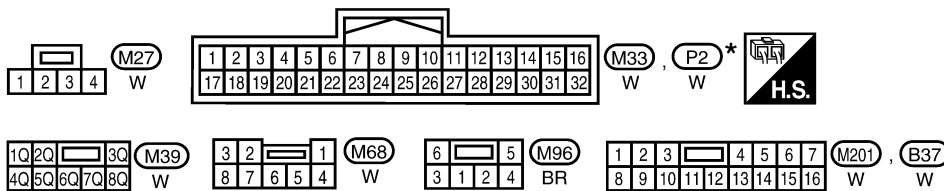
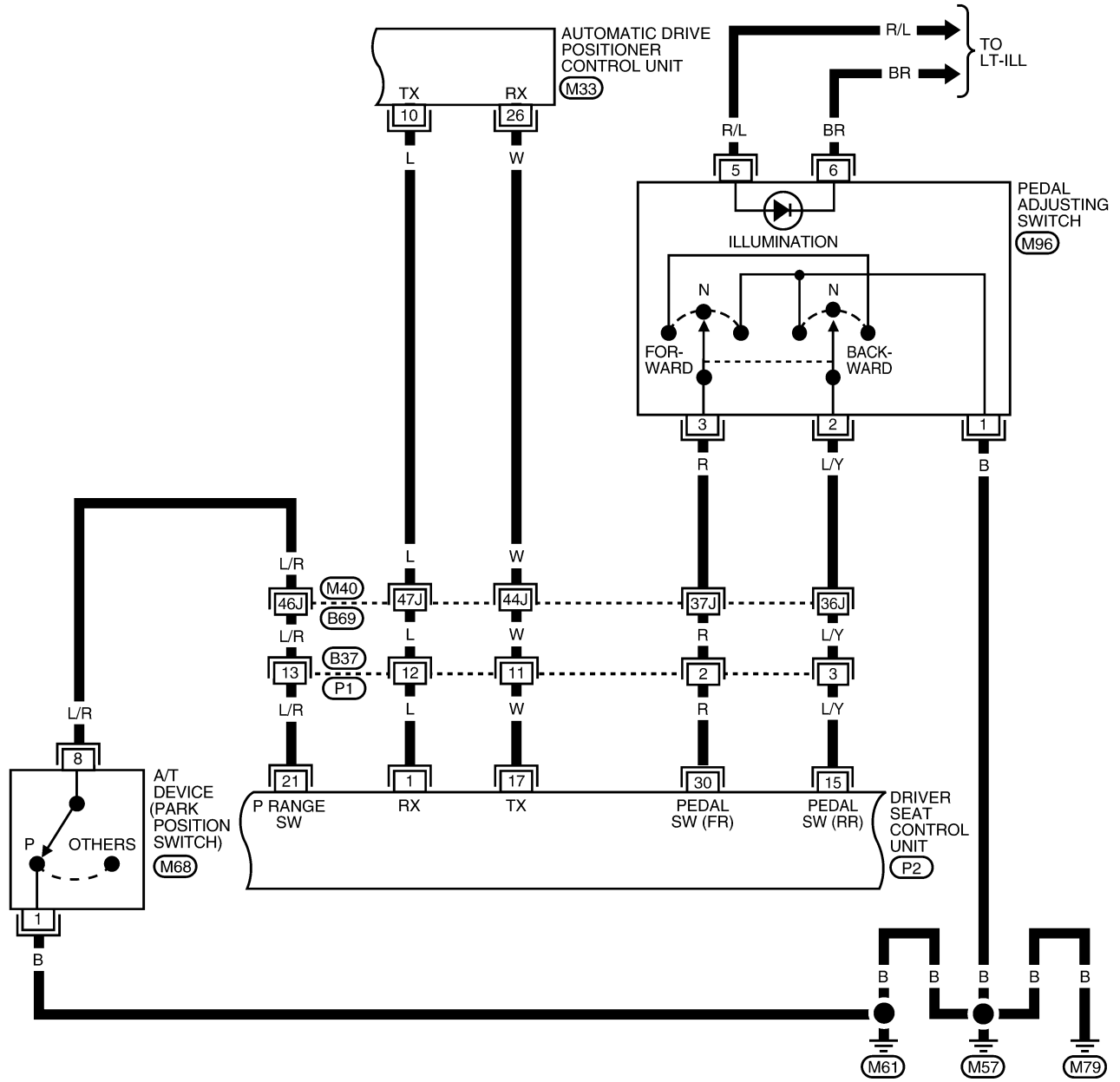

REFER TO THE FOLLOWING.
 (M40) - SUPER MULTIPLE JUNCTION (SMJ)

*: THIS CONNECTOR IS NOT SHOWN IN "HARNESS LAYOUT" OF PG SECTION.

WIWA1369E

AUTOMATIC DRIVE POSITIONER

SE-AUT/DP-07

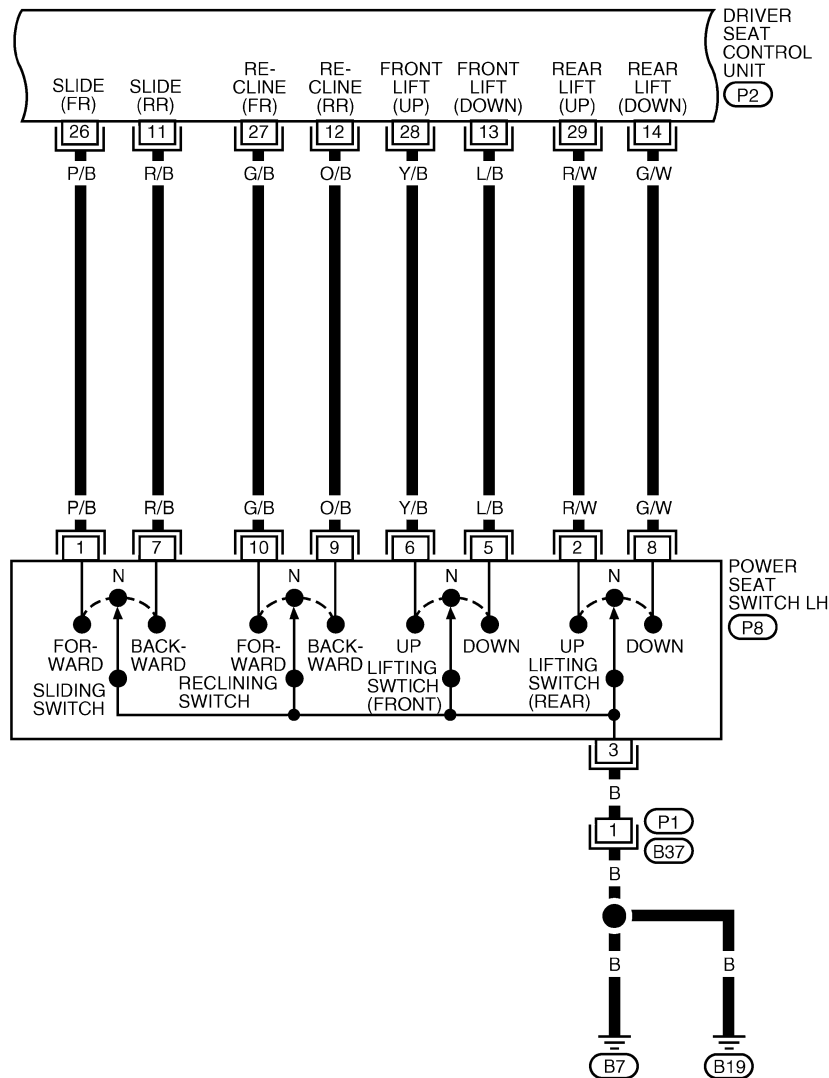

A
B
C
D
E
F
G
H
SE
J
K
L
M

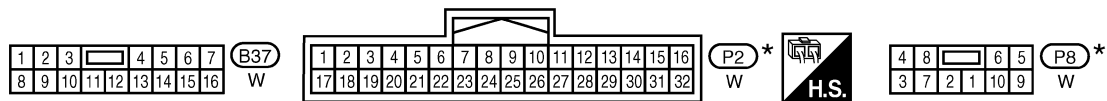

*: THIS CONNECTOR IS NOT SHOWN IN "HARNESS LAYOUT" OF PG SECTION.

LIWA0449E

AUTOMATIC DRIVE POSITIONER

SE-AUT/DP-08

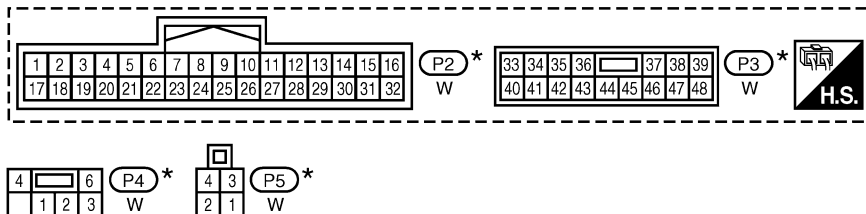
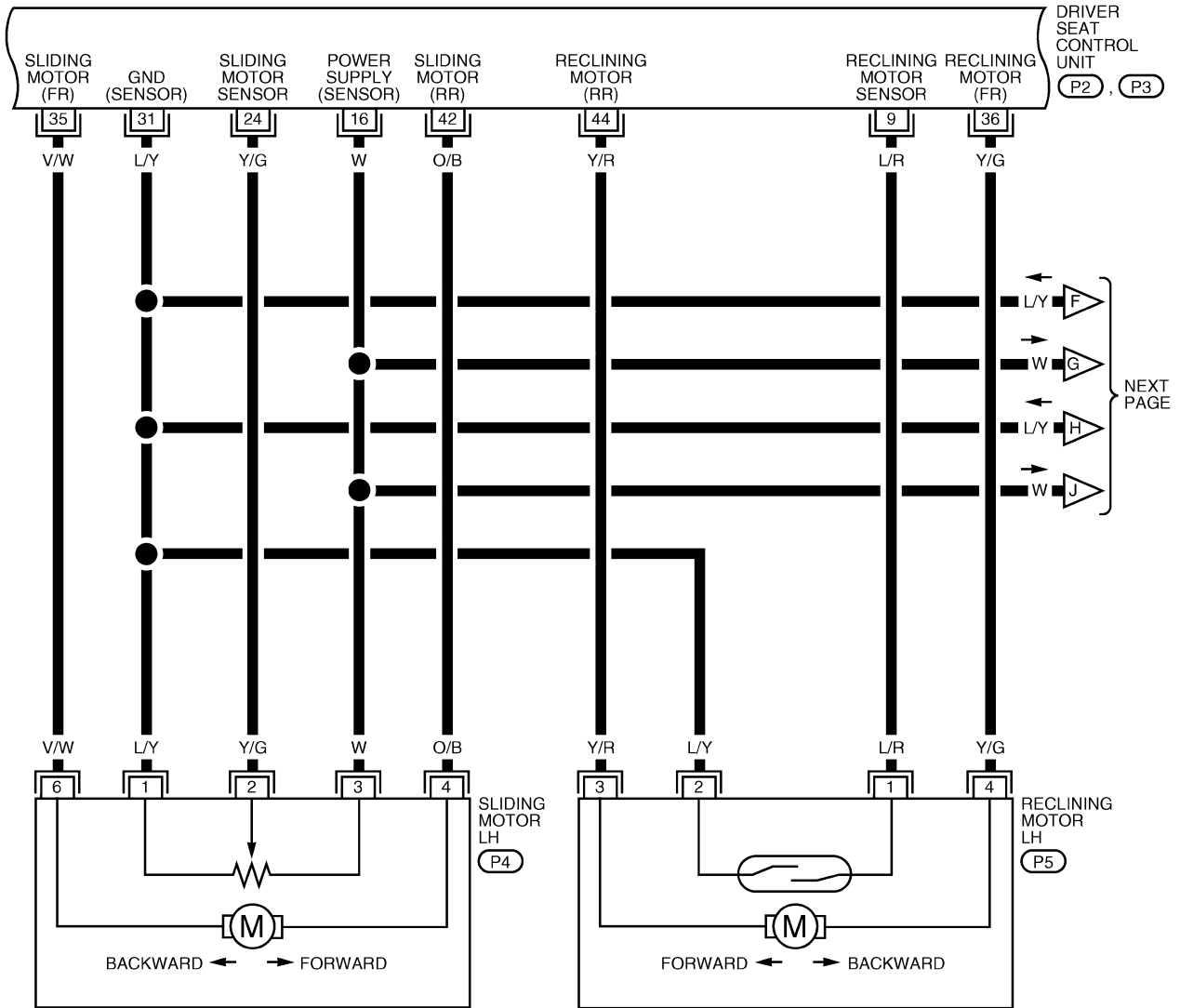

*: THIS CONNECTOR IS NOT SHOWN IN "HARNESS LAYOUT" OF PG SECTION.

LIWA0439E

AUTOMATIC DRIVE POSITIONER

SE-AUT/DP-09

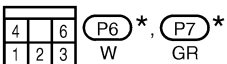
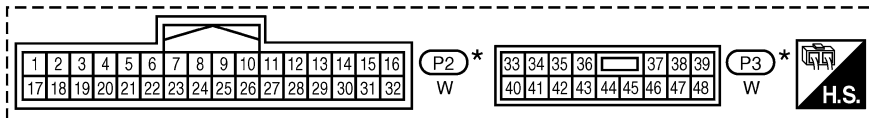
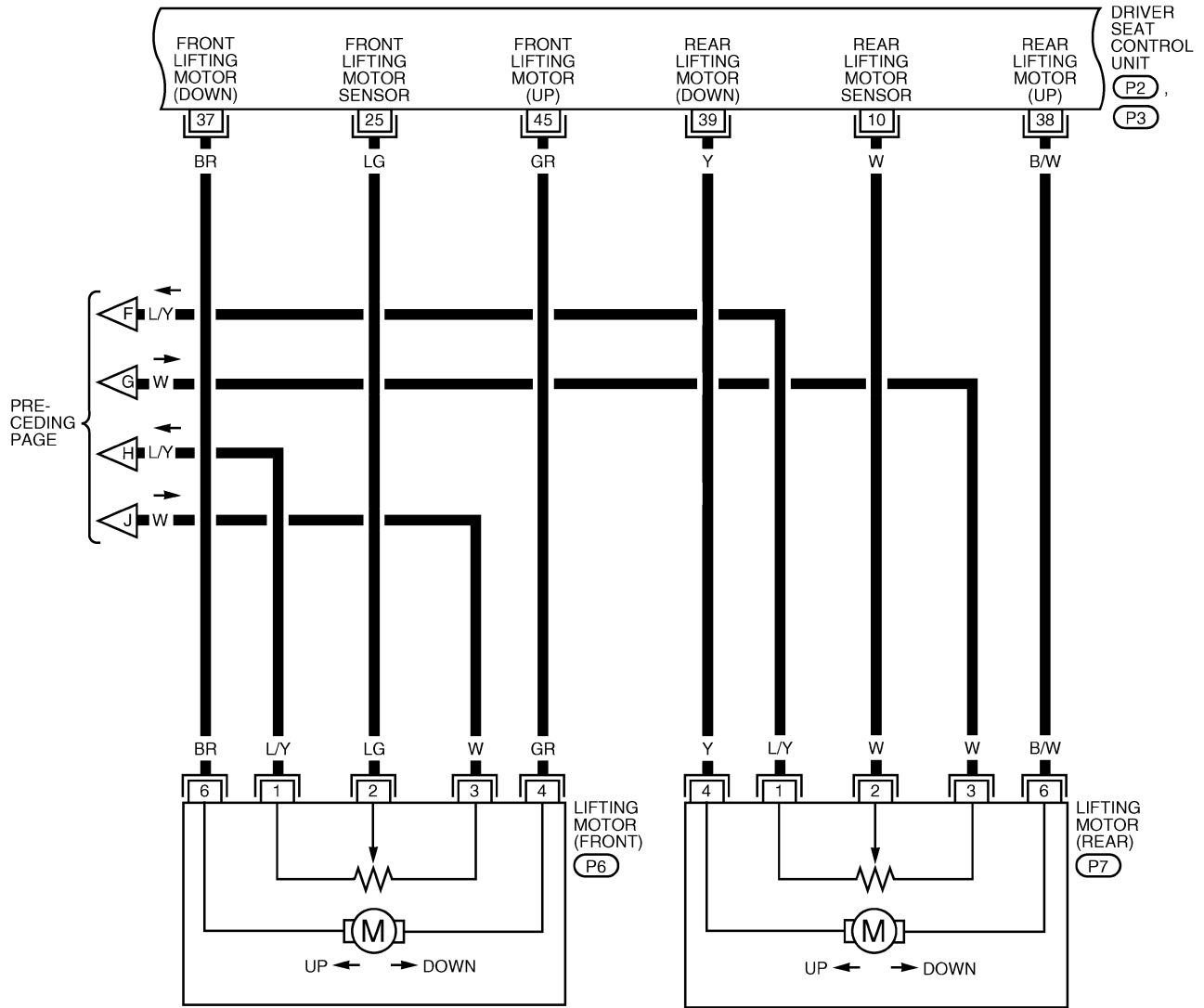

* : THIS CONNECTOR IS NOT SHOWN IN "HARNES LAYOUT" OF PG SECTION.

L1WA0440E

AUTOMATIC DRIVE POSITIONER

SE-AUT/DP-10

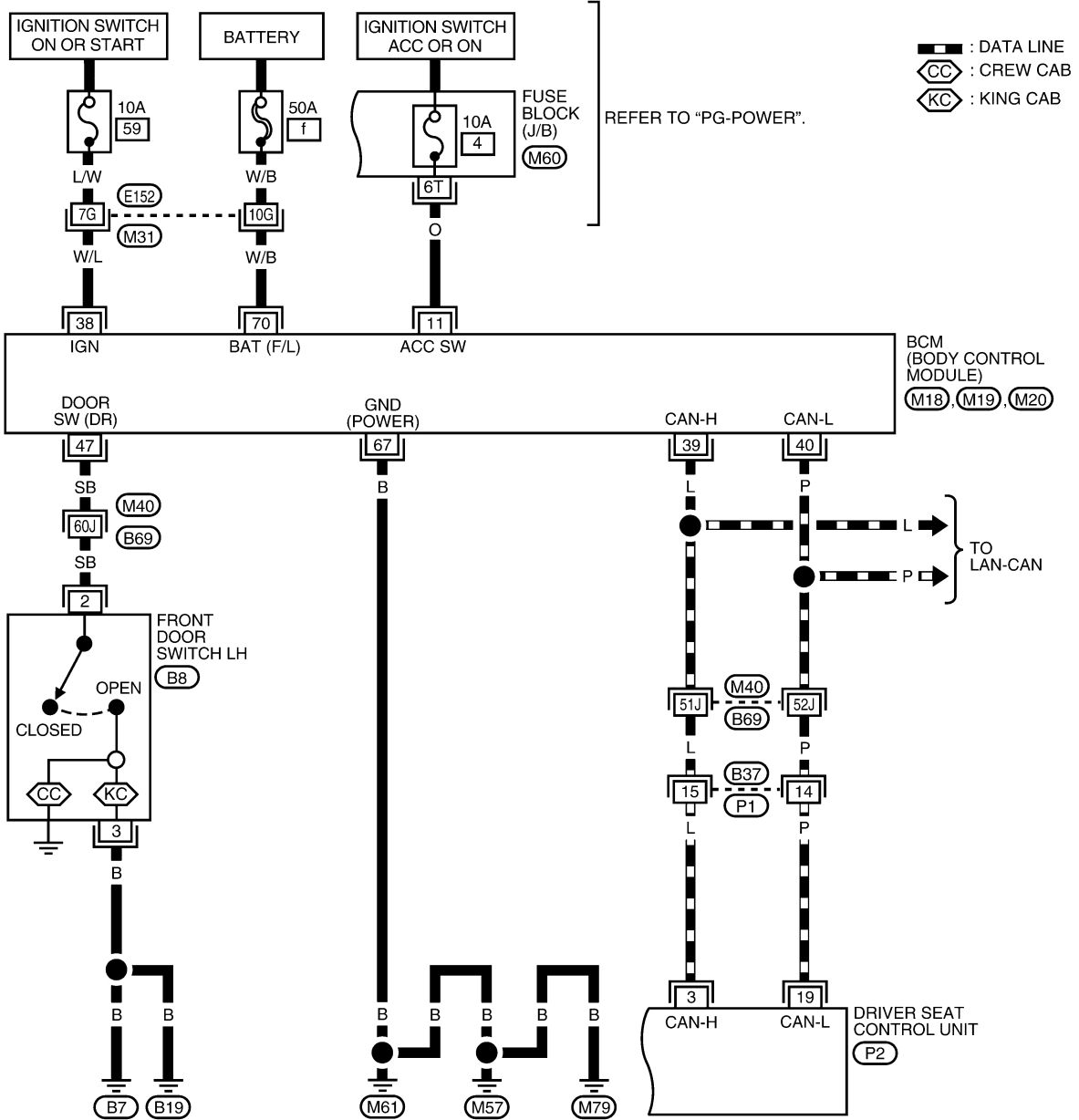

REFER TO THE FOLLOWING.
 M31, M40 - SUPER MULTIPLE JUNCTION (SMJ)

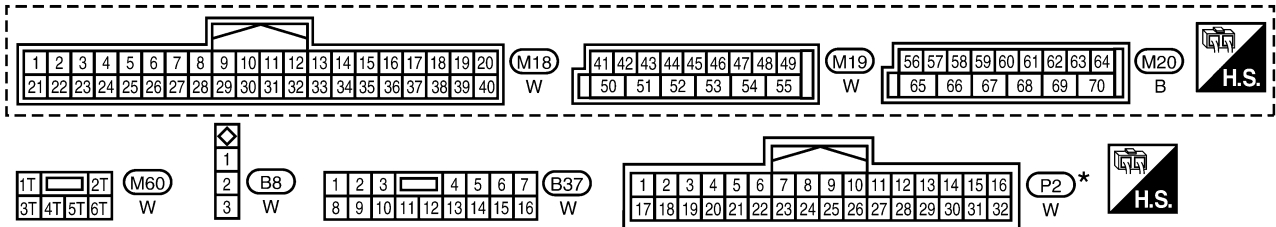

*: THIS CONNECTOR IS NOT SHOWN IN "HARNESS LAYOUT" OF PG SECTION.

WIWA1370E

AUTOMATIC DRIVE POSITIONER

Terminals and Reference Values for BCM

EIS004FI

Refer to [BCS-12, "Terminals and Reference Values for BCM"](#) .

Driver Seat Control Unit Harness Connector Terminal Layout

EIS0043I

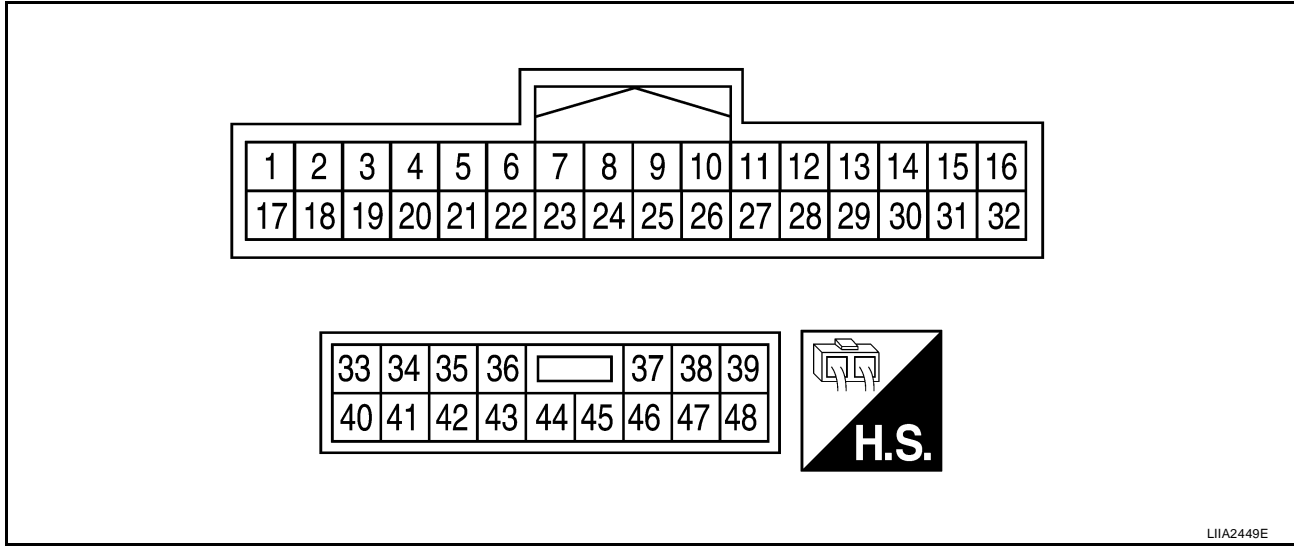

LIIA2449E

Terminals and Reference Values for Driver Seat Control Unit

EIS004FJ

Terminal	Wire Color	Item	Condition	Voltage (V) (Approx.)
1	L	UART LINE (RX)	Pedal adjusting switch ON (FORWARD or BACKWARD operation)	<p style="text-align: right;">PIIA4813E</p>
3	L	CAN-H	—	—
6	O	Ignition switch (ON or START)	Ignition switch (ON or START position)	Battery voltage
9	L/R	Reclining motor sensor signal	ON (seat reclining motor operation)	<p style="text-align: right;">SIIA0692J</p>
			Other than above	0 or 5
10	W	Rear lifting motor sensor signal	ON (rear lifting motor operation)	<p style="text-align: right;">SIIA0693J</p>
			Other than above	0 or 5
11	R/B	Sliding switch BACKWARD signal	ON (seat sliding switch BACKWARD operation)	0
			Other than above	Battery voltage

AUTOMATIC DRIVE POSITIONER

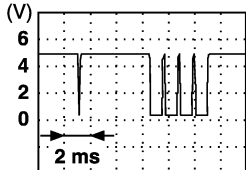
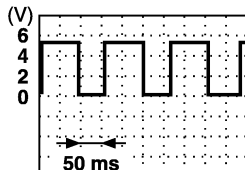
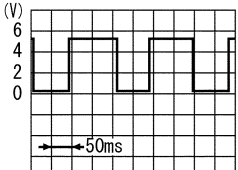
Terminal	Wire Color	Item	Condition	Voltage (V) (Approx.)
12	O/B	Reclining switch BACKWARD signal	ON (seat reclining switch BACKWARD operation)	0
			Other than above	Battery voltage
13	L/B	Front lifting switch DOWN signal	ON (front lifting switch DOWN operation)	0
			Other than above	Battery voltage
14	G/W	Rear lifting switch DOWN signal	ON (rear lifting switch DOWN operation)	0
			Other than above	Battery voltage
15	L/Y	Pedal adjusting switch BACKWARD signal	ON (pedal adjusting switch BACKWARD operation)	0
			Other than above	Battery voltage
16	W	Seat sensor power	Ignition switch ON	5
17	W	UART LINE (TX)	Pedal adjusting switch ON (FORWARD or BACKWARD operation)	 PIIA4814E
19	P	CAN-L	—	—
21	L/R	A/T device (park position switch) signal	A/T selector lever in P position	0
			A/T selector lever other than P position with ignition key in ignition cylinder	Battery voltage
24	Y/G	Seat sliding motor sensor signal	ON (seat sliding motor operation)	 PIIA3277E
			Other than above	0 or 5
25	LG	Front lifting motor sensor signal	ON (front lifting motor operation)	 SIIA0691J
			Other than above.	0 or 5
26	P/B	Seat sliding switch FORWARD signal	ON (seat sliding switch FORWARD operation)	0
			Other than above	Battery voltage
27	G/B	Seat reclining switch FORWARD signal	ON (seat reclining switch FORWARD operation)	0
			Other than above	Battery voltage
28	Y/B	Front lifting switch UP signal	ON (front lifting switch UP operation)	0
			Other than above	Battery voltage

AUTOMATIC DRIVE POSITIONER

Terminal	Wire Color	Item	Condition	Voltage (V) (Approx.)	
29	R/W	Rear lifting switch UP signal	ON (rear lifting switch UP operation)	0	A
			Other than above	Battery voltage	B
30	R	Pedal adjusting switch FORWARD signal	ON (pedal adjusting switch FORWARD operation)	0	C
			Other than above	Battery voltage	
31	L/Y	Sensor ground	—	0	
32	B	Ground	—	0	D
33	L/B	Battery power supply (PTC)	—	Battery voltage	
35	V/W	Sliding motor FORWARD output signal	Sliding switch FORWARD operation (Motor operated)	Battery voltage	E
			Other than above	0	
36	Y/G	Reclining motor FORWARD output signal	Reclining switch FORWARD operation (Motor operated)	Battery voltage	F
			Other than above	0	
37	BR	Front lifting motor DOWN output signal	Front lifting switch DOWN operation (Motor operated)	Battery voltage	G
			Other than above	0	
38	B/W	Rear lifting motor UP output signal	Rear lifting switch UP operation (Motor operated)	Battery voltage	H
			Other than above	0	
39	Y	Rear lifting motor DOWN output signal	Rear lifting switch DOWN operation (Motor operated)	Battery voltage	SE
			Other than above	0	
40	Y/R	Battery power supply	—	Battery voltage	J
42	O/B	Sliding motor BACKWARD output signal	Sliding switch BACKWARD operation (Motor operated)	Battery voltage	
			Other than above	0	K
44	Y/R	Reclining motor BACKWARD output signal	Reclining switch BACKWARD operation (Motor operated)	Battery voltage	L
			Other than above	0	
45	GR	Front lifting motor UP output signal	Front lifting switch UP operation (Motor operated)	Battery voltage	M
			Other than above	0	
48	B/W	Ground	—	0	

AUTOMATIC DRIVE POSITIONER

Automatic Drive Positioner Control Unit Harness Connector Terminal Layout

EIS00A3J

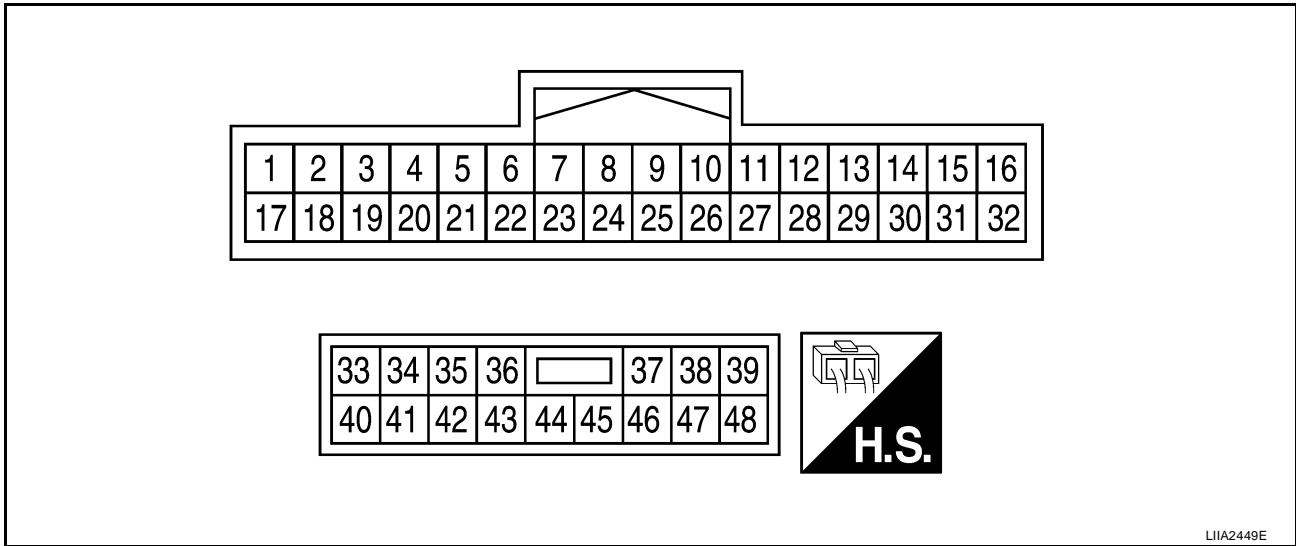

Terminals and Reference Values for Automatic Drive Positioner Control Unit

EIS004FK

Terminal	Wire Color	Item	Condition	Voltage (V) (Approx.)
2	LG	Changeover switch RH signal	Changeover switch in RH position	0
			Other than above	5
3	Y/B	Mirror switch UP signal	Mirror switch in UP position	0
			Other than above	5
4	V/W	Mirror switch LEFT signal	Mirror switch in LEFT position	0
			Other than above	5
5	R/B	Mirror sensor (RH vertical) signal	Mirror motor RH is operated UP or DOWN	Changes between 3.4 (close to peak) 0.6 (close to valley)
6	L/Y	Mirror sensor (LH vertical) signal	Mirror motor LH is operated UP or DOWN	Changes between 3.4 (close to peak) 0.6 (close to valley)
8	BR/Y	Pedal sensor input signal	Pedal position front end	0.5
			Pedal position rear end	4.5
9	LG/B	Seat memory switch 1 signal	Memory switch 1 ON	0
			Memory switch 1 OFF	5
10	L	UART LINE (TX)	Pedal adjusting switch ON (FORWARD or BACKWARD operation)	<p style="text-align: right;">PIIA4813E</p>
12	P	Seat memory switch indicator 1 signal	Memory switch 1 ON	0
			Memory switch 1 OFF	Battery voltage
13	Y/G	Seat memory switch indicator 2 signal	Memory switch 2 ON	0
			Memory switch 2 OFF	Battery voltage
14	GR/R	Mirror motor RH UP signal	Mirror motor RH is operated UP	1.5 - Battery voltage
			Other than above	0
15	V/R	Mirror motor RH LEFT signal	Mirror motor RH is operated LEFT	1.5 - Battery voltage
			Other than above	0

AUTOMATIC DRIVE POSITIONER

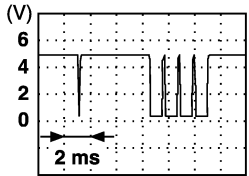
Terminal	Wire Color	Item	Condition	Voltage (V) (Approx.)
16	O	Mirror motor LH DOWN signal	Mirror motor LH is operated DOWN	1.5 - Battery voltage
			Other than above	0
		Mirror motor LH RIGHT signal	Mirror motor LH is operated RIGHT	1.5 - Battery voltage
			Other than above	0
18	BR/W	Changeover switch LH signal	Changeover switch in LH position	0
			Other than above	5
19	SB	Mirror switch DOWN signal	Mirror switch in DOWN position	0
			Other than above	5
20	GR	Mirror switch RIGHT signal	Mirror switch in RIGHT position	0
			Other than above	5
21	L/W	Mirror sensor (RH horizontal) signal	Mirror motor RH is operated LEFT or RIGHT	Changes between 3.4 (close to left edge) 0.6 (close to right edge)
22	G	Mirror sensor (LH horizontal) signal	Mirror motor LH is operated LEFT or RIGHT	Changes between 3.4 (close to left edge) 0.6 (close to right edge)
24	G/O	Seat memory set switch signal	Set switch 1 ON	0
			Set switch 1 OFF	5
25	P/L	Seat memory switch 2 signal	Memory switch 2 ON	0
			Memory switch 2 OFF	5
26	W	UART LINE (RX)	Pedal adjusting switch ON (FORWARD or BACKWARD operation)	 <p style="text-align: right; font-size: small;">PIIA4814E</p>
30	Y	Mirror motor RH DOWN signal	Mirror motor RH is operated DOWN	1.5 - Battery voltage
			Other than above	0
		Mirror motor RH RIGHT signal	Mirror motor RH is operated RIGHT	1.5 - Battery voltage
			Other than above	0
31	R	Mirror motor LH UP signal	Mirror motor LH is operated UP	1.5 - Battery voltage
			Other than above	0
32	BR	Mirror motor LH LEFT signal	Mirror motor LH is operated LEFT	1.5 - Battery voltage
			Other than above	0
33	W/L	Sensor power supply	—	5
34	Y/R	Battery power supply	—	Battery voltage
37	G	Pedal adjusting motor FORWARD signal	Pedal adjusting motor FORWARD operation (Motor operated)	Battery voltage
			Other than above	0
39	L/B	Battery power supply	—	Battery voltage
40	B/W	Ground	—	0
41	W/G	Sensor ground	—	0
45	R	Pedal adjusting motor BACKWARD signal	Pedal adjusting motor BACKWARD operation (Motor operated)	Battery voltage
			Other than above	0
48	B	Ground	—	0

AUTOMATIC DRIVE POSITIONER

EIS004FL

Work Flow

1. Check the symptom and customer's requests.
2. Understand the system description. Refer to [SE-11, "System Description"](#) .
3. Perform the preliminary check. Refer to [SE-30, "Preliminary Check"](#) .
4. Check the self-diagnosis, results using CONSULT-II. Refer to [SE-32, "CONSULT-II Function \(AUTO DRIVE POS.\)"](#) .
5. Repair or replace depending on the self-diagnostic results.
6. Based on the trouble diagnosis chart, repair or replace the cause of the malfunction. Refer to [SE-35, "Symptom Chart"](#) .
7. Does the automatic drive positioner system operate normally?
If it is normal, GO TO 8.
If it is not normal, GO TO 3.
8. Inspection End.

Preliminary Check SETTING CHANGE FUNCTION

EIS004FM

The settings of the automatic driving positioner system can be changed, using CONSULT-II and the display in the center of the instrument panel.

×: Applicable –: Not applicable

Setting item	Content	CONSULT-II (WORK SUPPORT)	Display unit	Default setting	Factory setting
SEAT SLIDE VOLUME SET	The distance at exiting operation can be selected from the following 3 modes.	40mm	—	×	×
		80mm		—	—
		150mm		—	—
Sliding Front Seat When Entry/ Exiting Vehicle	The seat sliding turnout and return at entry/exit can be selected: ON (operated)–OFF (not operated)	ON	ON: Indicator lamp ON	—	×
		OFF	OFF: Indicator lamp OFF	×	—
Reset custom settings*	All settings to default.	—	Default: Setting button ON	—	—

It is possible to set sliding front seat for entry/exit of vehicle by pressing set switch.

Content	Setting change operation	Indicator LEDs
The seat sliding turnout and return at entry/exit can be operated.	Press the set switch for more than 10 seconds	Blinking twice
The seat sliding turnout and return at entry/exit can not be operated.		Blinking once

*: Setting of sliding front seat for entry/exit of vehicle is ON at factory-shipment. But if custom settings are reset, setting turns OFF.

NOTE:

After the setting is registered, the new setting is effective, even if the battery is disconnected.

BCM Power Supply and Ground Circuit Check

EIS00B75

Refer to [BCS-16, "BCM Power Supply and Ground Circuit Check"](#) .

AUTOMATIC DRIVE POSITIONER

EIS00B76

Power Supply and Ground Circuit Check

1. CHECK CONTROL UNIT FUSES AND FUSIBLE LINK

Check if any of the following fuses for the driver seat control unit and automatic drive positioner control unit are blown.

Unit	Power source	Fuse No.
Driver seat control unit	START power supply	2 (10A)
Driver seat control unit and automatic drive positioner control unit	Battery power supply	22 (15A)
	Battery power supply	f (50A)

OK or NG

OK >> GO TO 2.

NG >> If fuse is blown, be sure to eliminate cause of malfunction before installing new fuse.

2. CHECK DRIVER SEAT CONTROL UNIT POWER SUPPLY CIRCUIT

1. Disconnect driver seat control unit.
2. Check voltage between driver seat control unit connector and ground.

Connector	Terminals		Power source	Ignition switch	Voltage (V) (Approx.)
	(+)	(-)			
P3	33	Ground	Battery power supply	—	Battery voltage
	40		Battery power supply	—	Battery voltage
P2	6		START power supply	START	Battery voltage

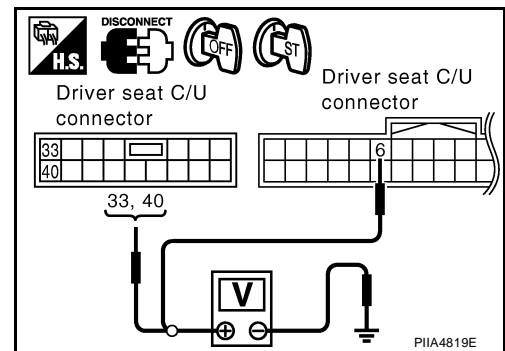

OK or NG

OK >> GO TO 3.

NG >> Repair or replace harness.

3. CHECK DRIVER SEAT CONTROL UNIT GROUND CIRCUIT

1. Turn ignition switch OFF.
2. Check continuity between the driver seat control unit connector P2 terminal 32, P3 terminal 48 and ground.

32 - Ground : Continuity should exist.

48 - Ground : Continuity should exist.

OK or NG

OK >> Driver seat control unit circuit check is OK. Check automatic drive positioner control unit. GO TO 4.

NG >> Repair or replace harness.

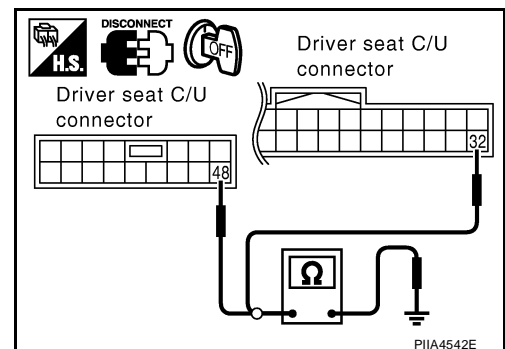

AUTOMATIC DRIVE POSITIONER

4. CHECK AUTOMATIC DRIVE POSITIONER CONTROL UNIT POWER SUPPLY CIRCUIT

1. Disconnect automatic drive positioner control unit.
2. Check voltage between automatic drive positioner control unit connector M34 terminals 34, 39 and ground.

Connector	Terminals		Ignition switch	Voltage (V) (Approx.)
	(+)	(-)		
M34	34	Ground	OFF	Battery voltage
	39		OFF	Battery voltage

OK or NG

- OK >> GO TO 5.
 NG >> Repair or replace harness.

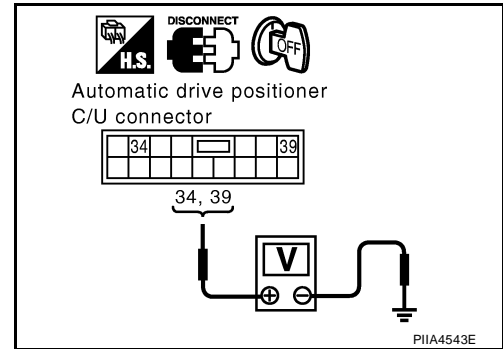

5. CHECK AUTOMATIC DRIVE POSITIONER CONTROL UNIT GROUND CIRCUIT

Check continuity between the automatic drive positioner control unit connector M34 terminals 40, 48 and ground.

- 40 - Ground : Continuity should exist.**
48 - Ground : Continuity should exist.

OK or NG

- OK >> Automatic drive positioner control unit circuit is OK.
 NG >> Repair or replace harness.

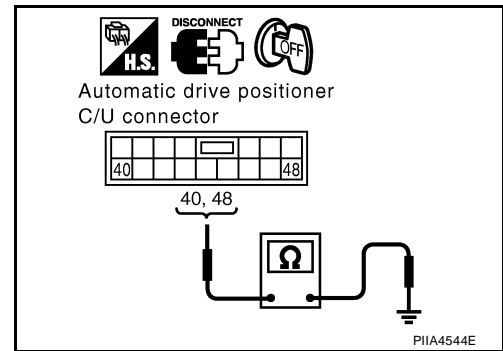

CONSULT-II Function (AUTO DRIVE POS.)

EIS004FN

CONSULT-II can display each diagnostic item using the diagnostic test modes shown following.

AUTO DRIVE POS. diagnostic mode	Description
WORK SUPPORT	Supports inspections and adjustments. Commands are transmitted to the driver seat control unit for setting the status suitable for required operation, input/output signals are received from the driver seat control unit and received data is displayed.
SELF-DIAG RESULTS	Displays driver seat control unit self-diagnosis results.
DATA MONITOR	Displays driver seat control unit input/output data in real time.
CAN DIAG SUPPORT MNTR	The result of transmit/receive diagnosis of CAN communication can be read.
ACTIVE TEST	Operation of electrical loads can be checked by sending drive signal to them.
ECU PART NUMBER	Driver seat control unit part number can be read.

CONSULT-II START PROCEDURE

Refer to [GI-38, "CONSULT-II Start Procedure"](#) .

AUTOMATIC DRIVE POSITIONER

SELF-DIAGNOSIS RESULTS

DISPLAY ITEM LIST

CONSULT-II display	Item	Malfunction is detected when...	Reference page
CAN COMM CIRC [U1000]	CAN communication	Malfunction is detected in CAN communication.	LAN-5
SEAT SLIDE [B2112]	Seat slide motor	When any manual and automatic operations are not performed, if any motor operations of seat slide is detected for 0.1 second or more, status is judged "Output error".	SE-37 SE-46
SEAT RECLINING [B2113]	Seat reclining motor	When any manual and automatic operations are not performed, if any motor operations of seat reclining is detected for 0.1 second or more, status is judged "Output error".	SE-38 SE-47
SEAT LIFTER FR [B2114]	Seat lifting FR motor	When any manual and automatic operations are not performed, if any motor operations of seat lifting FR is detected for 0.1 second or more, status is judged "Output error".	SE-39 SE-48
SEAT LIFTER RR [B2115]	Seat lifting RR motor	When any manual and automatic operations are not performed, if any motor operations of seat lifting RR is detected for 0.1 second or more, status is judged "Output error".	SE-41 SE-49
ADJ PEDAL MOTOR [B2117]	Pedal adjust motor	When any manual and automatic operations are not performed, if motor operations of seat pedal is detected for 0.1 second or more, status is judged "Output error".	SE-42 SE-50
ADJ PEDAL SENSOR [B2120]	Pedal adjust sensor	When pedal adjust sensor detects 0.5V or lower, or 4.5V or higher, for 0.5 seconds or more.	SE-50
DETENT SW [B2126]	Park SW	With the A/T selector lever in P position (park position switch OFF), if the vehicle speed of 7 km/h (4 MPH) or higher was input the park position switch input system is judged malfunctioning.	SE-71
UART COMM [B2128]	UART communication	Malfunction is detected in UART communication.	SE-75

NOTE:

- If park position switch error is detected, manual adjustable pedal operation cannot be performed when ignition switch turns ON.
- The displays of CAN communication and detection switch display error detecting condition from memory erase to the present on "TIME".
 - If error is detected in the past and present error is detected, "CRNT" is displayed.
 - If error is detected in the past and present error is not detected, "PAST" is displayed.
 - If error has never been detected, nothing is displayed on "TIME".
- Any items other than CAN communication and park switch count error detection frequency occurred after erase history to "1-127".
 - If error was detected in the past, error detection frequency from memory erase to the present is displayed on "TIME".
 - If error has never been detected, nothing is displayed on "TIME".
- Can clear the detected memory.
 - Normal: Clear memory in normal condition, history is erased and nothing is displayed on "TIME".
 - Error: Clear memory in error condition, error is detected again and "1" is displayed on "TIME".

AUTOMATIC DRIVE POSITIONER

DATA MONITOR SELECTION FROM MENU

Monitor item [OPERATION or UNIT]	Contents
SLIDE SW-FR	"ON/OFF" ON/OFF status judged from the sliding switch (FR) signal is displayed.
SLIDE SW-RR	"ON/OFF" ON/OFF status judged from the sliding switch (RR) signal is displayed.
RECLN SW-FR	"ON/OFF" ON/OFF status judged from the reclining switch (FR) signal is displayed.
RECLN SW-RR	"ON/OFF" ON/OFF status judged from the reclining switch (RR) signal is displayed.
LIFT FR SW-UP	"ON/OFF" ON/OFF status judged from the FR lifter switch (UP) signal is displayed.
LIFT FR SW-DN	"ON/OFF" ON/OFF status judged from the FR lifter switch (DOWN) signal is displayed.
LIFT RR SW-UP	"ON/OFF" ON/OFF status judged from the RR lifter switch (UP) signal is displayed.
LIFT RR SW-DN	"ON/OFF" ON/OFF status judged from the RR lifter switch (DOWN) signal is displayed.
MIR CON SW-UP	"ON/OFF" ON/OFF status judged from the door mirror switch (UP) signal is displayed.
MIR CON SW-DN	"ON/OFF" ON/OFF status judged from the door mirror switch (DOWN) signal is displayed.
MIR CON SW-RH	"ON/OFF" ON/OFF status judged from the door mirror switch (RIGHT) signal is displayed.
MIR CON SW-LH	"ON/OFF" ON/OFF status judged from the door mirror switch (LEFT) signal is displayed.
MIR CHNG SW-R	"ON/OFF" ON/OFF status judged from the door mirror switch (switching to RIGHT) signal is displayed.
MIR CHNG SW-L	"ON/OFF" ON/OFF status judged from the door mirror switch (switching to LEFT) signal is displayed.
SET SW	"ON/OFF" ON/OFF status judged from the setting switch signal is displayed.
PEDAL SW-FR	"ON/OFF" ON/OFF status judged from the pedal adjusting switch (FR) signal is displayed.
PEDAL SW-RR	"ON/OFF" ON/OFF status judged from the pedal adjusting switch (RR) signal is displayed.
MEMORY SW 1	"ON/OFF" ON/OFF status judged from the seat memory switch 1 signal is displayed.
MEMORY SW 2	"ON/OFF" ON/OFF status judged from the seat memory switch 2 signal is displayed.
DETENT SW	"ON/OFF" The A/T selector lever position "OFF (P position)/ON (other than P position)" judged from the park position switch signal is displayed.
STARTER SW	"ON/OFF" Ignition switch ON (START, ON)/OFF (ignition switch IGN, ACC, or OFF) status judged from the ignition switch signal is displayed.
SLIDE PULSE	— Value (32768) when battery connects is as standard. If it moves backward, the value increases. If it moves forward, the value decreases.
RECLN PULSE	— Value (32768) when battery connects is as standard. If it moves backward, the value increases. If it moves forward, the value decreases.
LIFT FR PULSE	— Value (32768) when battery connects is as standard. If it moves DOWN, the value increases. If it moves UP, the value decreases.
LIFT RR PULSE	— Value (32768) when battery connects is as standard. If it moves DOWN, the value increases. If it moves UP, the value decreases.
MIR/SEN RH R-L	"V" Voltage output from RH door mirror sensor (LH/RH) is displayed.
MIR/SEN RH U-D	"V" Voltage output from RH door mirror sensor (UP/DOWN) is displayed.
MIR/SEN LH R-L	"V" Voltage output from LH door mirror sensor (LH/RH) is displayed.
MIR/SEN LH U-D	"V" Voltage output from LH door mirror sensor (UP/DOWN) is displayed.
PEDAL SEN	"V" The pedal position (voltage) judged from the pedal adjust sensor signal is displayed.

AUTOMATIC DRIVE POSITIONER

ACTIVE TEST

CAUTION:

During vehicle driving, do not perform active test.

NOTE:

If active test is performed, reset automatic drive positioner seat memory after performing work.

DISPLAY ITEM LIST

Test item	Description
SEAT SLIDE	The sliding motor is activated by receiving the drive signal.
SEAT RECLINING	The reclining motor is activated by receiving the drive signal.
SEAT LIFTER FR	The lifting motor (front) is activated by receiving the drive signal.
SEAT LIFTER RR	The lifting motor (rear) is activated by receiving the drive signal.
PEDAL MOTOR	The pedal adjusting motor is activated by receiving the drive signal.
MEMORY SW INDCTR	The memory switch indicator is lit by receiving the drive signal.
MIRROR MOTOR RH	The RH mirror motor moves the mirror UP/DOWN and LEFT/RIGHT by receiving the drive signal.
MIRROR MOTOR LH	The LH mirror motor moves the mirror UP/DOWN and LEFT/RIGHT by receiving the drive signal.

CAN Communication Inspection Using CONSULT-II (Self-Diagnosis)

EIS004FO

1. SELF-DIAGNOSTIC RESULT CHECK

CAUTION:

If CONSULT-II is used with no connection of CONSULT-II CONVERTER, malfunctions might be detected in self-diagnosis depending on control unit which carries out CAN communication.

1. Connect to CONSULT-II, and select "AUTO DRIVE POS." on the "SELECT DIAG SYSTEM" screen.
2. Select "SELF-DIAG RESULTS" on "SELECT DIAG MODE" screen.
3. Check display content in self-diagnostic results.

CONSULT-II display code	Diagnosis item
U1000	INITIAL DIAG
	TRANSMIT DIAG
	ECM
	IPDM E/R
	METER/M&A
	I-KEY

Contents displayed

No malfunction>>Inspection End

Malfunction in CAN communication system>>After printing the monitor items, go to "CAN System". Refer to [LAN-5, "TROUBLE DIAGNOSIS"](#) .

Symptom Chart

EIS004FP

Symptom	Diagnoses / service procedure	Refer to page
Only setting change function cannot be set with display.	1. Preliminary check	SE-30
	2. CAN communication inspection using CONSULT-II (self-diagnosis)	SE-35
	3. If the above systems are normal, check display system	Navigation system AV-89

AUTOMATIC DRIVE POSITIONER

Symptom	Diagnoses / service procedure	Refer to page
A part of seat system does not operate (both automatically and manually).	1. Sliding motor circuit inspection	SE-37
	2. Reclining motor circuit inspection	SE-38
	3. Lifting motor (front) circuit inspection	SE-39
	4. Lifting motor (rear) circuit inspection	SE-41
	5. If the above systems are normal, replace the driver seat control unit	SE-11
A part of pedal adjust and door mirror does not operate (both automatically and manually).	1. Pedal adjusting motor circuit inspection	SE-42
	2. Mirror motor LH circuit check	SE-43
	3. Mirror motor RH circuit check	SE-45
	4. If the above systems are normal, replace the automatic drive positioner control unit.	SE-11
A part of seat system does not operate (only automatic operation).	1. Sliding sensor circuit inspection	SE-46
	2. Reclining sensor circuit inspection	SE-47
	3. Lifting sensor (front) circuit inspection	SE-48
	4. Lifting sensor (rear) circuit inspection	SE-49
	5. If the above systems are normal, replace the driver seat control unit	SE-11
A part of door mirror system does not operate (only automatic operation).	1. Mirror sensor LH circuit check	SE-51
	2. Mirror sensor RH circuit check	SE-53
	3. If the above systems are normal, replace the automatic drive positioner control unit.	SE-11
All of the automatic operations do not operate.	1. A/T device (park position switch) circuit inspection	SE-71
	2. UART communication line circuit inspection	SE-75
	3. Pedal adjusting sensor circuit inspection	SE-50
	4. If all the above systems are normal, replace the automatic drive positioner control unit.	SE-11
A part of seat system does not operate (only manual operation).	1. Sliding switch circuit inspection	SE-55
	2. Reclining switch circuit inspection	SE-57
	3. Lifting switch (front) circuit inspection	SE-58
	4. Lifting switch (rear) circuit inspection	SE-60
	5. If the above systems are normal, replace the driver seat control unit	SE-11
A part of pedal adjust and door mirror does not operate (only manual operation).	1. Pedal adjusting switch circuit inspection	SE-62
	2. Door mirror remote control switch (change over switch) circuit inspection	SE-64
	3. Door mirror remote control switch (mirror switch) switching circuit inspection	SE-65
	4. If the above systems are normal, replace the automatic drive positioner control unit	SE-11
Automatic drive positioner system does not operate (only memory switch operation).	1. Seat memory switch circuit inspection	SE-67
	2. If the above systems are normal, replace the driver seat control unit	SE-11
Seat memory indicator lamps 1 and 2 do not illuminate.	1. Seat memory indicator lamp circuit inspection	SE-69
	2. If all the above systems are normal, replace the driver seat control unit.	SE-11
The Entry/Exiting does not operate when door is opened and closed (the Entry/Exiting operates with key switch).	1. Front door switch circuit inspection	SE-73
	2. If all the above systems are normal, replace the BCM.	BCS-26

AUTOMATIC DRIVE POSITIONER

Symptom	Diagnoses / service procedure	Refer to page
Door mirror system does not operate (only manual operation).	1. Door mirror remote control switch ground circuit inspection	SE-67
Door mirror system does not operate (only automatic operation).	1. Door mirror sensor power supply and ground circuit inspection	SE-70
Seat system does not operate (only manual operation).	1. Power seat switch ground circuit inspection	SE-61

Sliding Motor Circuit Inspection

EIS004FO

1. CHECK SEAT SLIDING MECHANISM

Check the following.

- Operation malfunction caused by sliding rail deformation, pinched harness or other foreign materials
- Operation malfunction caused by foreign materials adhered to the sliding motor LH or sliding rail connector rod
- Operation malfunction and interference with other parts by poor installation

OK or NG

- OK >> GO TO 2.
- NG >> Repair the malfunctioning part and check again.

2. CHECK FUNCTION

With CONSULT-II

Check operation with "SEAT SLIDE" in ACTIVE TEST.

Test item	Description
SEAT SLIDE	The sliding motor is activated by receiving the drive signal.

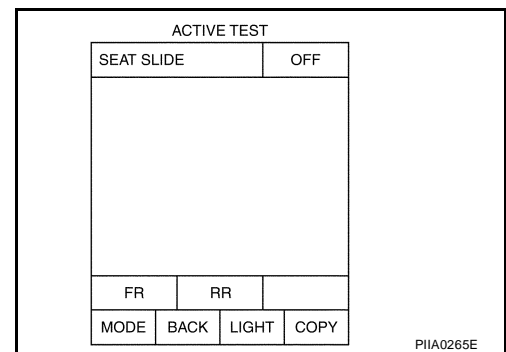

Without CONSULT-II

GO TO 3.

OK or NG

- OK >> Sliding motor circuit is OK.
- NG >> GO TO 3.

3. CHECK SLIDING MOTOR CIRCUIT HARNESS CONTINUITY

1. Turn ignition switch OFF.
2. Disconnect driver seat control unit and sliding motor LH.
3. Check continuity between driver seat control unit connector P3 terminals 35, 42 and sliding motor connector P4 terminals 4, 6.

35 - 6 : Continuity should exist.

42 - 4 : Continuity should exist.

4. Check continuity between driver seat control unit connector P3 terminals 35, 42 and ground.

35 - Ground : Continuity should not exist.

42 - Ground : Continuity should not exist.

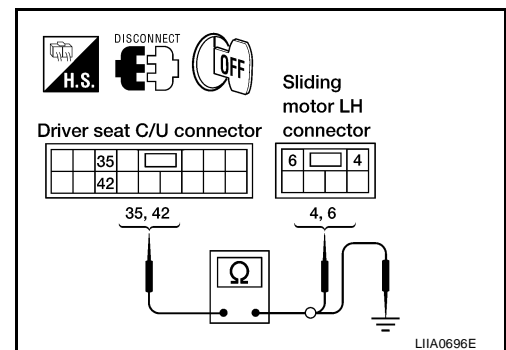

OK or NG

- OK >> GO TO 4.
- NG >> Repair or replace harness.

AUTOMATIC DRIVE POSITIONER

4. CHECK DRIVER SEAT CONTROL UNIT OUTPUT SIGNAL

1. Connect the driver seat control unit and sliding motor LH.
2. Check voltage between driver seat control unit connector and ground.

Connector	Terminals		Condition	Voltage (V) (Approx.)
	(+)	(-)		
P3	35	Ground	Sliding switch ON (FORWARD operation)	Battery voltage
			Other than above	0
	42		Sliding switch ON (BACKWARD operation)	Battery voltage
			Other than above	0

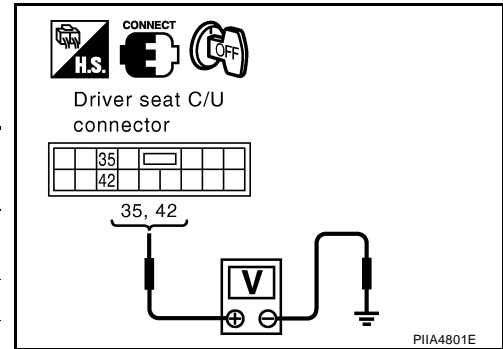

OK or NG

- OK >> Replace sliding motor LH. Refer to [SE-85, "FRONT SEAT"](#) .
 NG >> Replace driver seat control unit. Refer to [SE-85, "FRONT SEAT"](#) .

Reclining Motor LH Circuit Inspection

EIS004FR

1. CHECK SEAT RECLINING MECHANISM

Check the following.

- Operation malfunction caused by an interference with the center pillar or center console
- Operation malfunction and interference with other parts by poor installation

OK or NG

- OK >> GO TO 2.
 NG >> Repair the malfunctioning part and check again.

2. CHECK FUNCTION

With CONSULT-II

Check operation with "SEAT RECLINING" in ACTIVE TEST.

Test item	Description
SEAT RECLINING	The reclining motor LH is activated by receiving the drive signal.

Without CONSULT-II

GO TO 3.

OK or NG

- OK >> Reclining motor LH circuit is OK.
 NG >> GO TO 3.

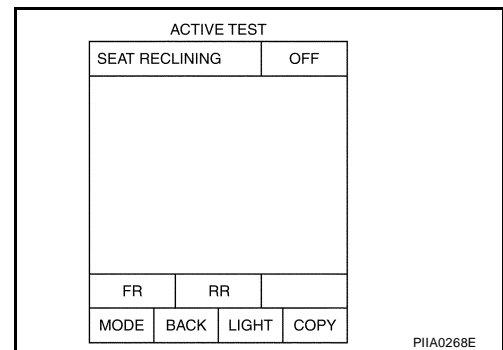

AUTOMATIC DRIVE POSITIONER

3. CHECK RECLINING MOTOR CIRCUIT HARNESS CONTINUITY

1. Turn ignition switch OFF.
2. Disconnect driver seat control unit and reclining motor LH.
3. Check continuity between driver seat control unit connector P3 terminals 36, 44 and reclining motor LH connector P5 terminals 3, 4.

36 - 4 : Continuity should exist.

44 - 3 : Continuity should exist.

4. Check continuity between driver seat control unit connector P3 terminals 36, 44 and ground.

36 - Ground : Continuity should not exist.

44 - Ground : Continuity should not exist.

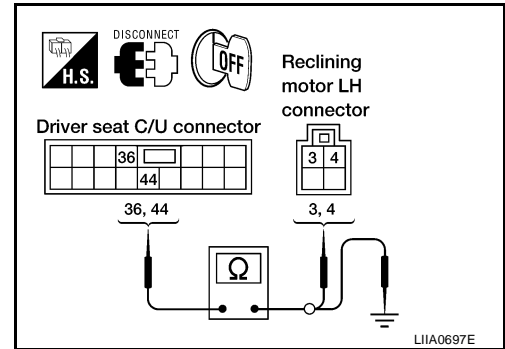

OK or NG

OK >> GO TO 4.

NG >> Repair or replace harness.

4. CHECK DRIVER SEAT CONTROL UNIT OUTPUT SIGNAL

1. Connect the driver seat control unit and reclining motor LH.
2. Check voltage between driver seat control unit connector and ground.

Connector	Terminals		Condition	Voltage (V) (Approx.)
	(+)	(-)		
P3	36	Ground	Reclining switch ON (FORWARD operation)	Battery voltage
			Other than above	0
	44		Reclining switch ON (BACKWARD operation)	Battery voltage
			Other than above	0

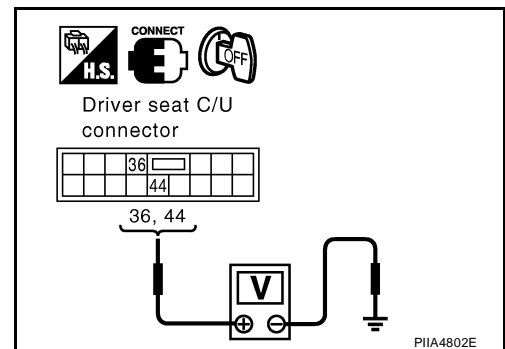

OK or NG

OK >> Replace reclining motor LH. Refer to [SE-85, "FRONT SEAT"](#) .

NG >> Replace driver seat control unit. Refer to [SE-85, "FRONT SEAT"](#) .

Lifting Motor (Front) Circuit Inspection

EIS004FS

1. CHECK SEAT LIFTING (FRONT) MECHANISM

Check the following.

- Operation malfunction caused by lifter mechanism deformation, pinched harness or other foreign materials
- Operation malfunction caused by foreign materials adhered to the lifting motor (front) or lead screws
- Operation malfunction and interference with other parts by installation

OK or NG

OK >> GO TO 2.

NG >> Repair the malfunctioning part and check again.

AUTOMATIC DRIVE POSITIONER

2. CHECK FUNCTION

With CONSULT-II

Check operation with "SEAT LIFTER FR" in ACTIVE TEST.

Test item	Description
SEAT LIFTER FR	The lifting motor (front) is activated by receiving the drive signal.

Without CONSULT-II

GO TO 3.

OK or NG

- OK >> Lifting motor (front) circuit is OK.
 NG >> GO TO 3.

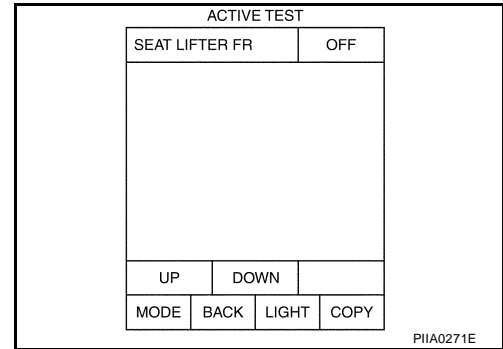

3. CHECK LIFTING MOTOR (FRONT) CIRCUIT HARNESS CONTINUITY

- Turn ignition switch OFF.
- Disconnect driver seat control unit and lifting motor (front).
- Check continuity between driver seat control unit connector P3 terminals 37, 45 and lifting motor (front) connector P6 terminals 4, 6.

37 - 6 : Continuity should exist.

45 - 4 : Continuity should exist.

- Check continuity between driver seat control unit connector P3 terminals 37, 45 and ground.

37 - Ground : Continuity should not exist.

45 - Ground : Continuity should not exist.

OK or NG

- OK >> GO TO 4.
 NG >> Repair or replace harness.

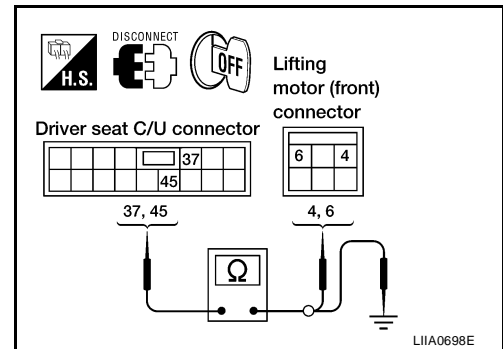

4. CHECK DRIVER SEAT CONTROL UNIT OUTPUT SIGNAL

- Connect the driver seat control unit and lifting motor (front).
- Check voltage between driver seat control unit connector and ground.

Connector	Terminals		Condition	Voltage (V) (Approx.)
	(+)	(-)		
P3	37	Ground	Lifting switch (front) ON (DOWN operation)	Battery voltage
			Other than above	0
	45		Lifting switch (front) ON (UP operation)	Battery voltage
			Other than above	0

OK or NG

- OK >> Replace lifting motor (front). Refer to [SE-85, "FRONT SEAT"](#) .
 NG >> Replace driver seat control unit. Refer to [SE-85, "FRONT SEAT"](#) .

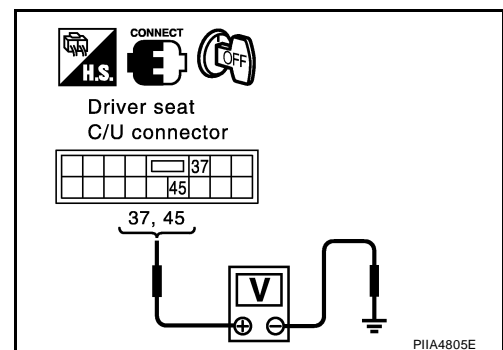

AUTOMATIC DRIVE POSITIONER

EIS004FT

Lifting Motor (Rear) Circuit Inspection

1. CHECK SEAT LIFTING (REAR) MECHANISM

Check the following.

- Operation malfunction caused by lifter mechanism deformation or pinched harness or other foreign materials
- Operation malfunction caused by foreign materials adhered to the lifting motor (rear) or lead screws
- Operation malfunction and interference with other parts by poor installation

OK or NG

OK >> GO TO 2.

NG >> Repair the malfunctioning part and check again.

2. CHECK FUNCTION

Ⓟ With CONSULT-II

Check operation with "SEAT LIFTER RR" in ACTIVE TEST.

Test item	Description
SEAT LIFTER RR	The lifting motor (rear) is activated by receiving the drive signal.

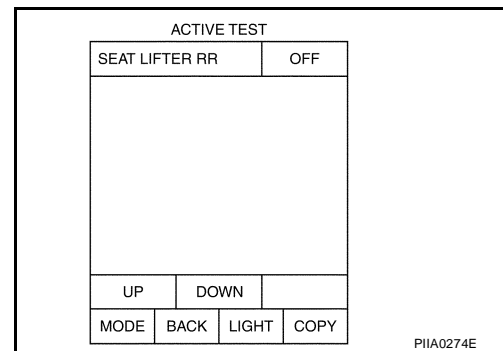

ⓧ Without CONSULT-II

GO TO 3.

OK or NG

OK >> Lifting motor (rear) circuit is OK.

NG >> GO TO 3.

3. CHECK LIFTING MOTOR (REAR) CIRCUIT HARNESS CONTINUITY

1. Turn ignition switch OFF.
2. Disconnect driver seat control unit and lifting motor (rear).
3. Check continuity between driver seat control unit connector P3 terminals 38, 39 and lifting motor (rear) connector P7 terminals 4, 6.

38 - 6 : Continuity should exist.

39 - 4 : Continuity should exist.

4. Check continuity between driver seat control unit P3 terminals 38, 39 and ground.

38 - Ground : Continuity should not exist.

39 - Ground : Continuity should not exist.

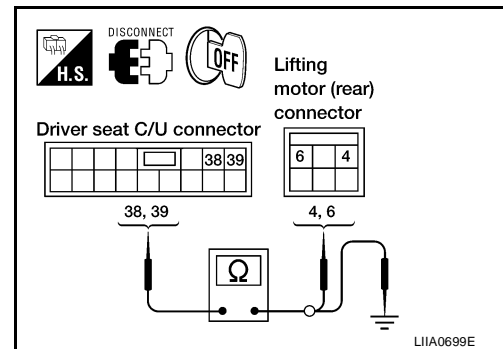

OK or NG

OK >> GO TO 4.

NG >> Repair or replace harness.

AUTOMATIC DRIVE POSITIONER

4. CHECK DRIVER SEAT CONTROL UNIT OUTPUT SIGNAL

1. Connect the driver seat control unit and lifting motor (rear).
2. Check voltage between driver seat control unit connector and ground.

Connector	Terminals		Condition	Voltage (V) (Approx.)
	(+)	(-)		
P3	38	Ground	Lifting switch (rear) ON (UP operation)	Battery voltage
			Other than above	0
	39		Lifting switch (rear) ON (DOWN operation)	Battery voltage
			Other than above	0

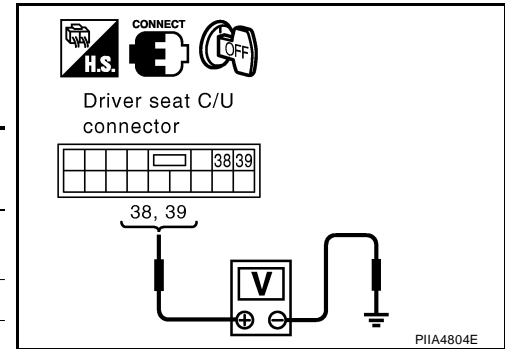

OK or NG

- OK >> Replace lifting motor (rear). Refer to [SE-85, "FRONT SEAT"](#) .
 NG >> Replace driver seat control unit. Refer to [SE-85, "FRONT SEAT"](#) .

Pedal Adjusting Motor Circuit Inspection

EIS004FU

1. CHECK PEDAL ADJUSTING MECHANISM

Check the following.

- Operation malfunction caused by pedal adjusting mechanism deformation or pinched harness or other foreign materials
- Operation malfunction and interference with other parts by poor installation

OK or NG

- OK >> GO TO 2.
 NG >> Repair the malfunctioning part and check again.

2. CHECK FUNCTION

With CONSULT-II

Check operation with "PEDAL" in ACTIVE TEST.

Test item	Description
ADJ PEDAL MOTOR	The pedal adjusting motor is activated by receiving the drive signal.

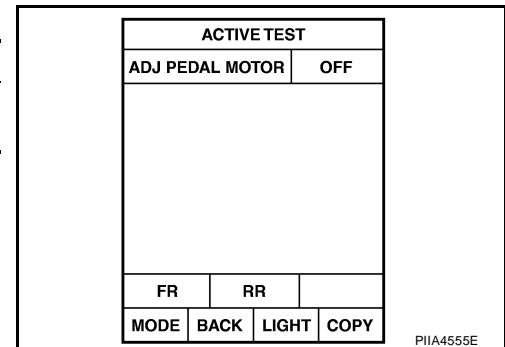

Without CONSULT-II

GO TO 3.

OK or NG

- OK >> Pedal adjusting motor circuit is OK.
 NG >> GO TO 3.

AUTOMATIC DRIVE POSITIONER

3. CHECK PEDAL ADJUSTING MOTOR CIRCUIT HARNESS CONTINUITY

1. Turn ignition switch OFF.
2. Disconnect automatic drive positioner control unit and pedal adjusting motor.
3. Check continuity between automatic drive positioner control unit connector M34 terminals 37, 45 and pedal adjusting motor connector E109 terminals 1, 2.

37 - 1 : Continuity should exist.

45 - 2 : Continuity should exist.

4. Check continuity between automatic drive positioner control unit connector M34 terminals 37, 45 and ground.

37 - Ground : Continuity should not exist.

45 - Ground : Continuity should not exist.

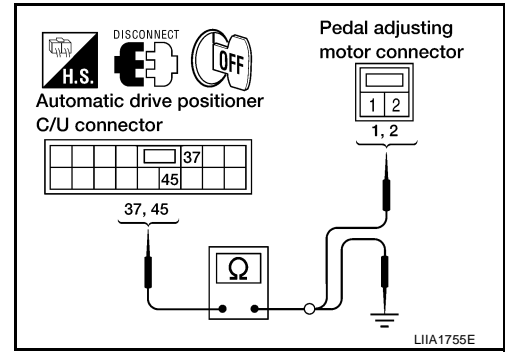

OK or NG

OK >> GO TO 4.

NG >> Repair or replace harness.

4. CHECK AUTOMATIC DRIVE POSITIONER CONTROL UNIT OUTPUT SIGNAL

1. Connect the automatic drive positioner control unit and pedal adjusting motor.
2. Check voltage between automatic drive positioner control unit connector and ground.

Connector	Terminals		Condition	Voltage (V) (Approx.)
	(+)	(-)		
M34	37	Ground	Pedal adjusting switch ON (FORWARD operation)	Battery voltage
			Other than above	0
	45		Pedal adjusting switch ON (BACKWARD operation)	Battery voltage
			Other than above	0

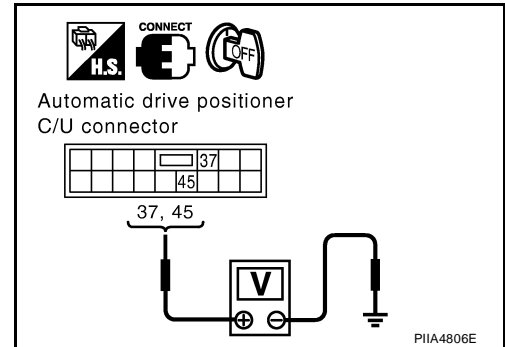

OK or NG

OK >> Replace adjustable accelerator pedal assembly. Refer to [ACC-3, "ADJUSTABLE ACCELERATOR PEDAL ASSEMBLY"](#).

NG >> Replace automatic drive positioner control unit.

Mirror Motor LH Circuit Check

EIS004FV

1. CHECK DOOR MIRROR LH MECHANISM

Check the following items.

Operation malfunction caused by a foreign object caught in door mirror face edge.

OK or NG

OK >> GO TO 2.

NG >> Repair the malfunctioning parts, and check the symptom again.

AUTOMATIC DRIVE POSITIONER

2. CHECK FUNCTION

With CONSULT-II

Check the operation with "MIRROR MOTOR LH" in the ACTIVE TEST.

Test item	Description
MIRROR MOTOR LH	The mirror motor LH moves the mirror UP/DOWN and LEFT/RIGHT by receiving the drive signal.

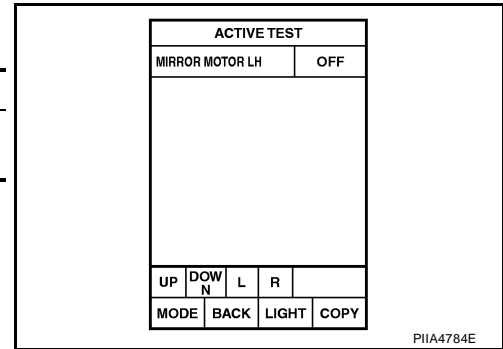

Without CONSULT-II

GO TO 3.

OK or NG

- OK >> Mirror motor LH circuit is OK.
- NG >> GO TO 3.

3. CHECK DOOR MIRROR MOTOR LH CIRCUIT HARNESS CONTINUITY

- Turn ignition switch OFF.
- Disconnect automatic drive positioner control unit and door mirror LH.
- Check continuity between automatic drive positioner control unit connector M33 terminals 16, 31, 32 and door mirror LH connector D4 terminals 1, 2, 3.

- 16 - 3 : Continuity should exist.**
- 31 - 1 : Continuity should exist.**
- 32 - 2 : Continuity should exist.**

- Check continuity between automatic drive positioner control unit connector M33 terminals 16, 31, 32 and ground.

- 16 - Ground : Continuity should not exist.**
- 31 - Ground : Continuity should not exist.**
- 32 - Ground : Continuity should not exist.**

OK or NG

- OK >> GO TO 4.
- NG >> Repair or replace harness.

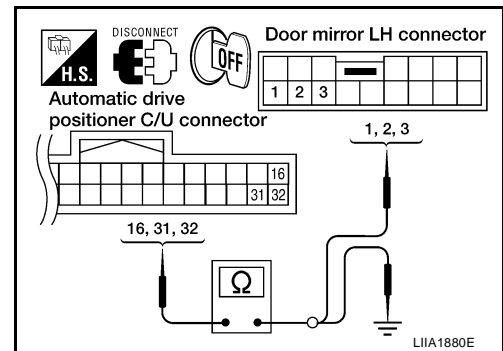

4. CHECK MIRROR MOTOR SIGNAL

- Turn ignition switch to ACC.
- Check voltage between door mirror LH connector and ground.

Connector	Terminals		Condition	Voltage (V) (Approx.)
	(+)	(-)		
D4	1	Ground	When motor is operated UP	1.5 - Battery voltage
			Other than above	0
	2		When motor is operated LEFT	1.5 - Battery voltage
			Other than above	0
	3		When motor is operated DOWN or RIGHT	1.5 - Battery voltage
			Other than above	0

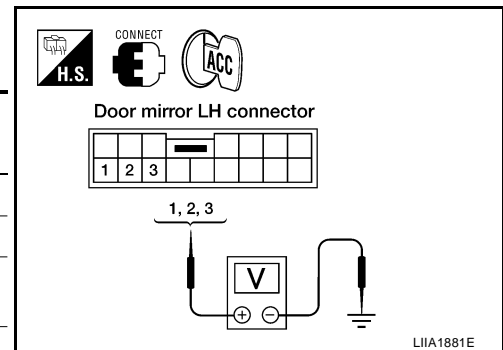

OK or NG

- OK >> Replace door mirror LH. Refer to [GW-118, "Door Mirror Assembly"](#).
- NG >> Repair or replace harness.

AUTOMATIC DRIVE POSITIONER

EIS004FW

Mirror Motor RH Circuit Check

1. CHECK DOOR MIRROR RH MECHANISM

Check the following items.

Operation malfunction caused by a foreign object caught in door mirror face edge.

OK or NG

OK >> GO TO 2.

NG >> Repair the malfunctioning parts, and check the symptom again.

2. CHECK FUNCTION

With CONSULT-II

Check the operation with "MIRROR MOTOR RH" in the ACTIVE TEST.

Test item	Description
MIRROR MOTOR RH	The mirror motor RH moves the mirror UP/DOWN and LEFT/RIGHT by receiving the drive signal.

Without CONSULT-II

GO TO 3.

OK or NG

OK >> Mirror motor RH circuit is OK.

NG >> GO TO 3.

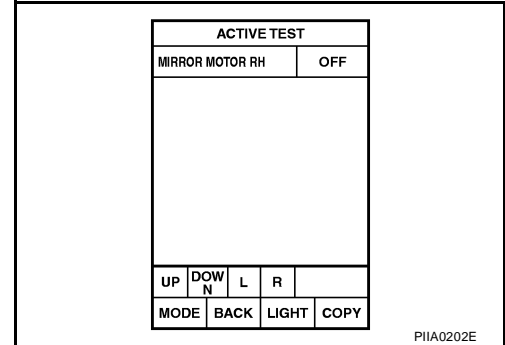

3. CHECK DOOR MIRROR RH CIRCUIT HARNESS CONTINUITY

- Turn ignition switch OFF.
- Disconnect automatic drive positioner control unit and door mirror RH.
- Check continuity between automatic drive positioner control unit connector M33 terminals 14, 15, 30 and door mirror RH connector D107 terminals 1, 2, 3.

14 - 1 : Continuity should exist.

15 - 2 : Continuity should exist.

30 - 3 : Continuity should exist.

- Check continuity between automatic drive positioner control unit connector M33 terminals 14, 15, 30 and ground.

14 - Ground : Continuity should not exist.

15 - Ground : Continuity should not exist.

30 - Ground : Continuity should not exist.

OK or NG

OK >> GO TO 4.

NG >> Repair or replace harness.

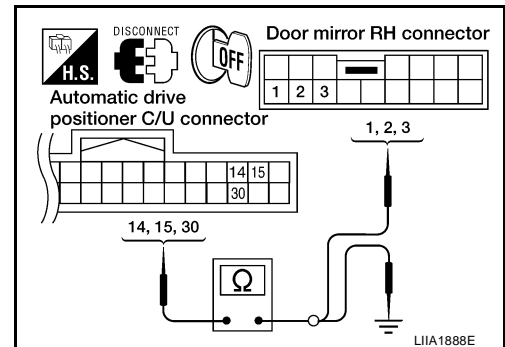

AUTOMATIC DRIVE POSITIONER

4. CHECK MIRROR MOTOR SIGNAL

1. Turn ignition switch to ACC.
2. Check voltage between door mirror RH connector and ground.

Connector	Terminals		Condition	Voltage (V) (Approx.)
	(+)	(-)		
D107	1	Ground	Mirror motor is operated UP	1.5 - Battery voltage
			Other than above	0
	2		Mirror motor is operated LEFT	1.5 - Battery voltage
			Other than above	0
	3		Mirror motor is operated DOWN or RIGHT	1.5 - Battery voltage
			Other than above	0

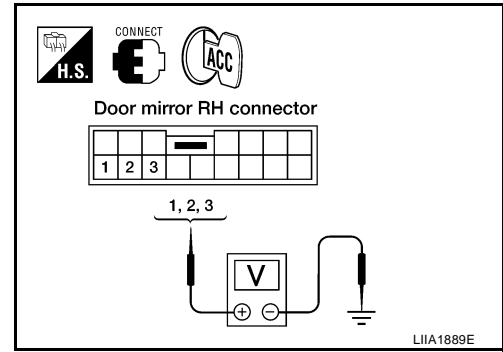

OK or NG

- OK >> Replace door mirror RH. Refer to [GW-118, "Door Mirror Assembly"](#) .
- NG >> Repair or replace harness.

Sliding Sensor Circuit Inspection

EIS004FX

1. CHECK FUNCTION

With CONSULT-II

Check operation with "SLIDE PULSE" on the DATA MONITOR to make sure the pulse changes.

Monitor item [OPERATION or UNIT]	Contents
SLIDE PULSE	— The seat sliding position (pulse) judged from the sliding sensor signal is displayed

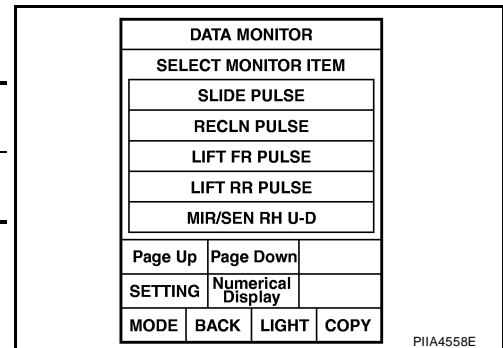

Without CONSULT-II

1. Turn ignition switch OFF.
2. Check signal between driver seat control unit connector and ground, with oscilloscope.

Connector	Terminals		Condition	Signal
	(+)	(-)		
P2	24	Ground	Sliding motor operation	<p style="text-align: right;">PIIA3277E</p>

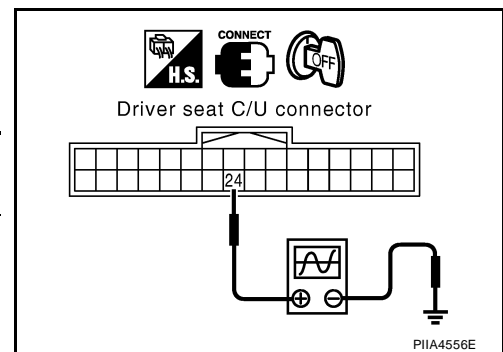

OK or NG

- OK >> Sliding sensor circuit is OK.
- NG >> GO TO 2.

AUTOMATIC DRIVE POSITIONER

2. CHECK SLIDING MOTOR SENSOR CIRCUIT HARNESS CONTINUITY

- Disconnect driver seat control unit connector and sliding motor LH.
- Check continuity between driver seat control unit connector P2 terminals 16, 24, 31 and sliding motor P4 terminals 1, 2, 3.

16 - 3 : Continuity should exist.
24 - 2 : Continuity should exist.
31 - 1 : Continuity should exist.

- Check continuity between driver seat control unit P2 terminals 24, 31 and ground.

16 - Ground : Continuity should not exist.
24 - Ground : Continuity should not exist.
31 - Ground : Continuity should not exist

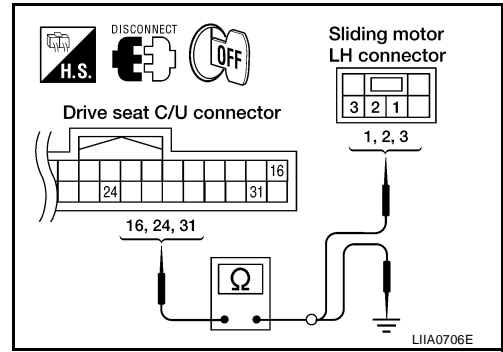

OK or NG

- OK >> Replace sliding motor LH. Refer to [SE-85, "FRONT SEAT"](#) .
 NG >> Repair or replace harness.

Reclining Sensor Circuit Inspection

EIS004FY

1. CHECK FUNCTION

Ⓜ With CONSULT-II

Check operation with "RECLN PULSE" on the DATA MONITOR to make sure the pulse changes.

Monitor item [OPERATION or UNIT]	Contents
RECLN PULSE	— The seat reclining position (pulse) judged from the reclining sensor is displayed

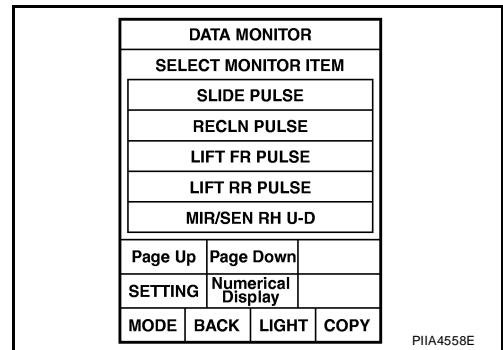

ⓧ Without CONSULT-II

- Turn ignition switch OFF.
- Check signal between driver seat control unit connector and ground, with oscilloscope.

Connector	Terminals		Condition	Signal
	(+)	(-)		
P2	9	Ground	Reclining motor operation	<p style="text-align: right;">PIIA3278E</p>

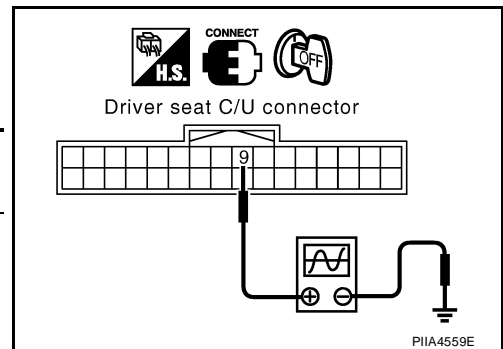

OK or NG

- OK >> Reclining sensor circuit is OK.
 NG >> GO TO 2.

AUTOMATIC DRIVE POSITIONER

2. CHECK RECLINING MOTOR SENSOR CIRCUIT HARNESS CONTINUITY

1. Disconnect driver seat control unit and reclining motor LH.
2. Check continuity between driver seat control unit connector P2 terminals 9, 31 and reclining motor LH connector P5 terminals 1, 2.

9 - 1 : Continuity should exist.
31 - 2 : Continuity should exist.

3. Check continuity between driver seat control unit connector P2 terminals 9, 31 and ground.

9 - Ground : Continuity should not exist.
31 - Ground : Continuity should not exist.

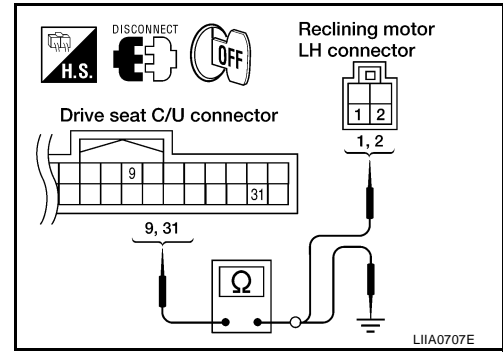

OK or NG

- OK >> Replace reclining motor LH. Refer to [SE-85, "FRONT SEAT"](#) .
- NG >> Repair or replace harness.

Lifting Sensor (Front) Circuit Inspection

EIS004FZ

1. CHECK FUNCTION

With CONSULT-II

Check operation with "LIFT FR PULSE" on the DATA MONITOR to make sure the pulse changes.

Monitor item [OPERATION or UNIT]	Contents
LIFT FR PULSE	— The front lifting position (pulse) judged from the lifting sensor (front) is displayed

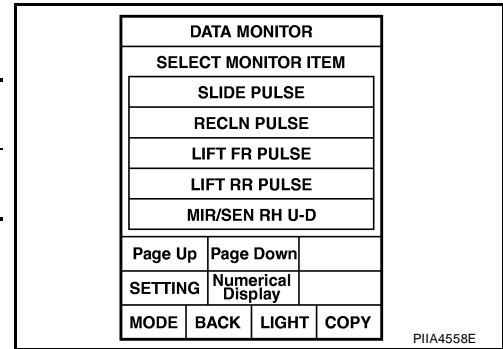

Without CONSULT-II

1. Turn ignition switch OFF.
2. Check signal between driver seat control unit connector and ground, with oscilloscope.

Connector	Terminals		Condition	Signal
	(+)	(-)		
P2	25	Ground	Lifting motor (front) operation	<p style="text-align: right;">PIIA3278E</p>

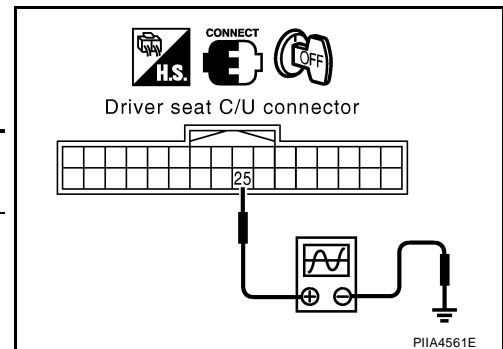

OK or NG

- OK >> Lifting sensor (front) is OK.
- NG >> GO TO 2.

AUTOMATIC DRIVE POSITIONER

2. CHECK LIFTING MOTOR (FRONT) SENSOR CIRCUIT HARNESS CONTINUITY

1. Disconnect driver seat control unit and lifting motor (front).
2. Check continuity between driver seat control unit connector P2 terminals 16, 25, 31 and lifting motor (front) connector P6 terminals 1, 2, 3.

16 - 3 : Continuity should exist.
25 - 2 : Continuity should exist.
31 - 1 : Continuity should exist.

3. Check continuity between driver seat control unit connector P2 terminals 16, 25, 31 and ground.

16 - Ground : Continuity should not exist.
25 - Ground : Continuity should not exist.
31 - Ground : Continuity should not exist.

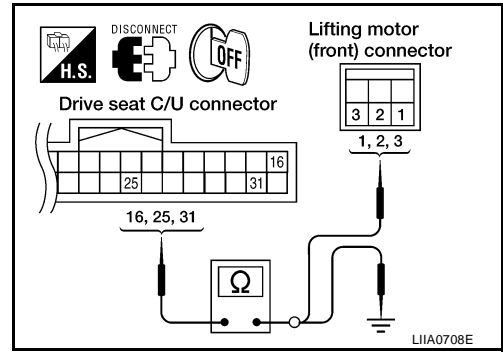

OK or NG

- OK >> Replace lifting motor (front). Refer to [SE-85, "FRONT SEAT"](#) .
 NG >> Repair or replace harness.

Lifting Sensor (Rear) Circuit Inspection

EIS004G0

1. CHECK FUNCTION

With CONSULT-II

Check operation with "LIFT RR PULSE" on the DATA MONITOR to make sure pulse changes.

Monitor item [OPERATION or UNIT]		
LIFT RR PULSE	—	The rear lifting position (pulse) judged from the lifting sensor (rear) is displayed.

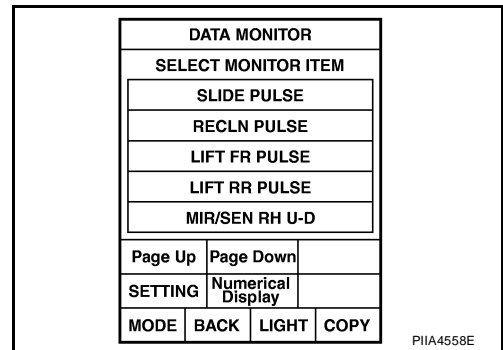

Without CONSULT-II

1. Turn ignition switch OFF.
2. Check signal between driver seat control unit connector and ground, with oscilloscope.

Connector	Terminals		Condition	Signal
	(+)	(-)		
P2	10	Ground	Lifting motor (rear) operation	

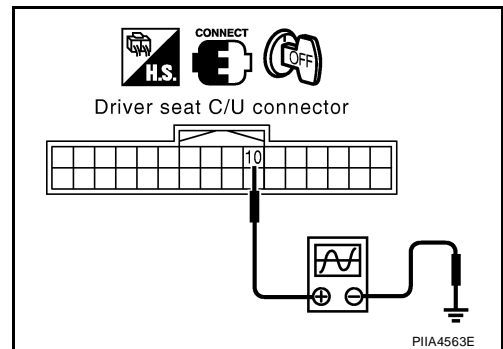

OK or NG

- OK >> Lifting sensor (rear) circuit is OK.
 NG >> GO TO 2.

AUTOMATIC DRIVE POSITIONER

2. CHECK LIFTING MOTOR (REAR) SENSOR CIRCUIT HARNESS CONTINUITY

1. Disconnect driver seat control unit and lifting motor (rear).
2. Check continuity between driver seat control unit connector P2 terminals 10, 16, 31 and lifting motor (rear) connector P7 terminals 1, 2, 3.

10 - 2 : Continuity should exist.
16 - 3 : Continuity should exist.
31 - 1 : Continuity should exist.

3. Check continuity between driver seat control unit connector P2 terminals 10, 16, 31 and ground.

10 - Ground : Continuity should not exist.
16 - Ground : Continuity should not exist.
31 - Ground : Continuity should not exist.

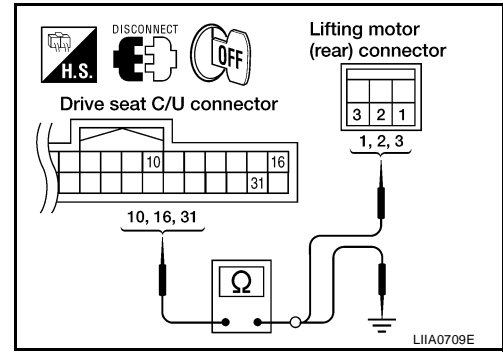

OK or NG

- OK >> Replace lifting motor (rear). Refer to [SE-85, "FRONT SEAT"](#) .
 NG >> Repair or replace harness.

Pedal Adjusting Sensor Circuit Inspection

EIS004G1

1. CHECK FUNCTION

With CONSULT-II

Operate the pedal adjusting switch with "PEDAL SEN" on the DATA MONITOR to make sure the voltage changes.

Monitor item [OPERATION or UNIT]	Contents
PEDAL SEN	"V"
	The pedal adjusting position (voltage) judged from the pedal adjust sensor signal is displayed.

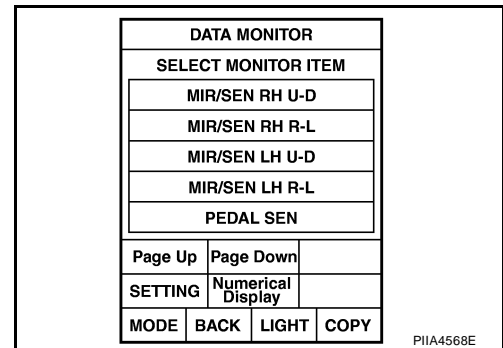

Without CONSULT-II

1. Turn ignition switch OFF.
2. Check voltage between automatic drive positioner control unit connector and ground.

Connector	Terminals		Condition	Voltage (V) (Approx.)
	(+)	(-)		
M33	8	Ground	Pedal front end position	0.5
			Pedal back end position	4.5

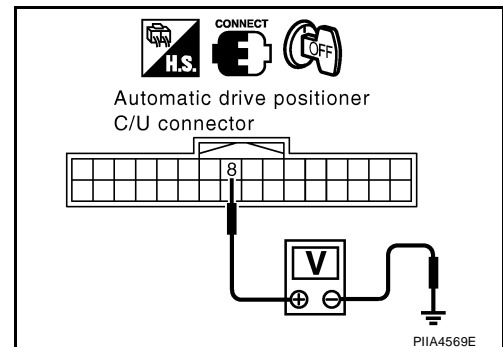

OK or NG

- OK >> Pedal adjusting sensor circuit is OK.
 NG >> GO TO 2.

AUTOMATIC DRIVE POSITIONER

2. CHECK PEDAL ADJUSTING SENSOR CIRCUIT HARNESS CONTINUITY

1. Disconnect automatic drive positioner control unit and pedal adjusting sensor.
2. Check continuity between automatic drive positioner connector M33, M34 terminals 8, 33, 41 and pedal adjusting sensor connector E110 terminals 3, 4, 5.

8 - 4 : **Continuity should exist.**

33 - 3 : **Continuity should exist.**

41 - 5 : **Continuity should exist.**

3. Check continuity between automatic drive positioner control unit connector M33, M34 terminals 8, 33, 41 and ground.

8 - Ground : **Continuity should not exist.**

33 - Ground : **Continuity should not exist.**

41 - Ground : **Continuity should not exist.**

OK or NG

OK >> Replace adjustable accelerator pedal assembly. Refer to [ACC-3, "ADJUSTABLE ACCELERATOR PEDAL ASSEMBLY"](#) .

NG >> Repair or replace harness.

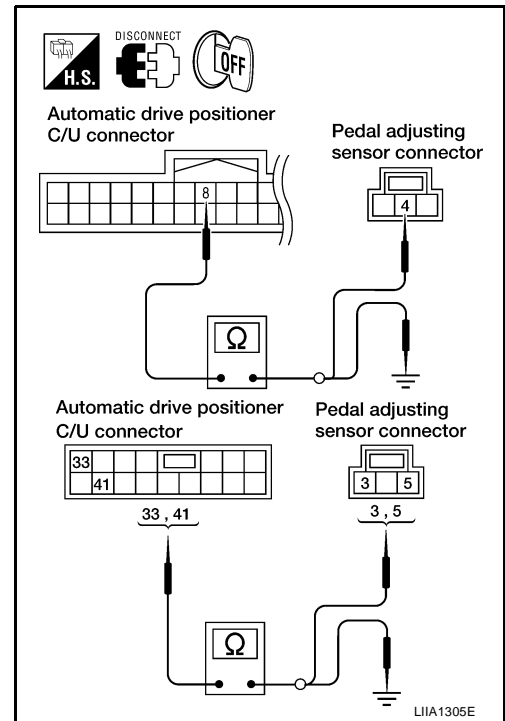

EIS004G2

Mirror Sensor LH Circuit Check

1. CHECK DOOR MIRROR FUNCTION

Check the following items.

Operation malfunction in memory control

NOTE:

If a door mirror face position is set to an implausible angle, the set position may not be reproduced.

OK or NG

OK >> GO TO 2.

NG >> Repair the malfunctioning parts, and check the symptom again.

AUTOMATIC DRIVE POSITIONER

2. CHECK MIRROR SENSOR

With CONSULT-II

Check that "ON" is displayed on "MIR/SE LH R-L, MIR/SE LH U-D" in the DATA MONITOR.

Monitor item [OPERATION or UNIT]		Contents
MIR/SE LH R-L	"V"	Voltage output from door mirror LH sensor (LH/RH) is displayed.
MIR/SE LH U-D	"V"	Voltage output from door mirror LH sensor (UP/DOWN) is displayed.

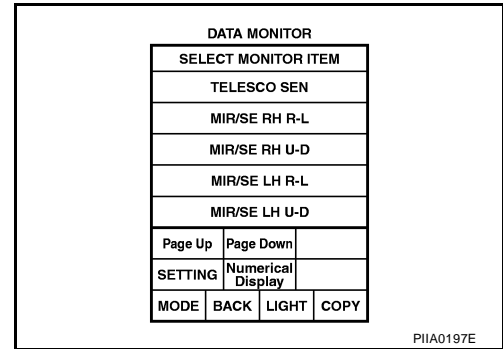

Without CONSULT-II

1. Turn ignition switch to ACC.
2. Check voltage between door mirror LH connector and ground.

Con-connector	Terminals		Condition	Voltage (V) (Approx.)
	(+)	(-)		
D4	7	Ground	Mirror motor is operated UP or DOWN	Changes between 3.4 (close to peak) – 0.6 (close to valley)
	8		Mirror motor is operated LEFT or RIGHT	Changes between 3.4 (close to right edge) – 0.6 (close to left edge)

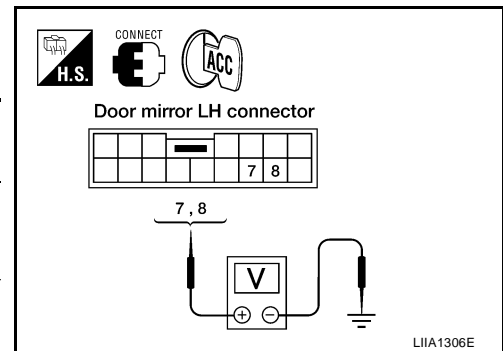

OK or NG

- OK >> Mirror sensor LH is OK.
- NG >> GO TO 3.

3. CHECK HARNESS CONTINUITY 1

1. Turn ignition switch OFF.
2. Disconnect automatic drive positioner control unit and door mirror LH.
3. Check continuity between automatic drive positioner control unit connector M34 terminals 33, 41 and door mirror LH connector D4 terminals 5, 6.

- 33 - 5 : Continuity should exist.**
- 41 - 6 : Continuity should exist.**

4. Check continuity between automatic drive positioner control unit connector M34 terminals 33, 41 and ground.

- 33 - Ground : Continuity should not exist.**
- 41 - Ground : Continuity should not exist.**

OK or NG

- OK >> GO TO 4.
- NG >> Repair or replace harness.

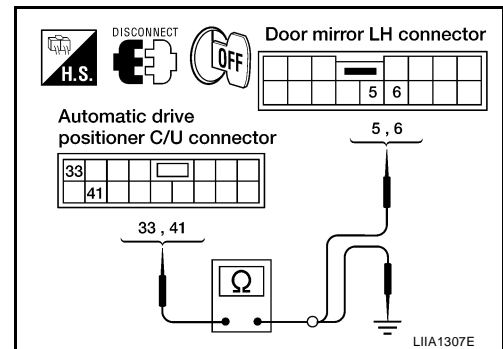

AUTOMATIC DRIVE POSITIONER

4. CHECK HARNESS CONTINUITY 2

1. Check continuity between automatic drive positioner control unit connector M33 terminals 6, 22 and door mirror LH connector D4 terminals 7, 8.

6 - 7 : Continuity should exist.

22 - 8 : Continuity should exist.

2. Check continuity between automatic drive positioner control unit connector M33 terminals 6, 22 and ground.

6 - Ground : Continuity should not exist.

22 - Ground : Continuity should not exist.

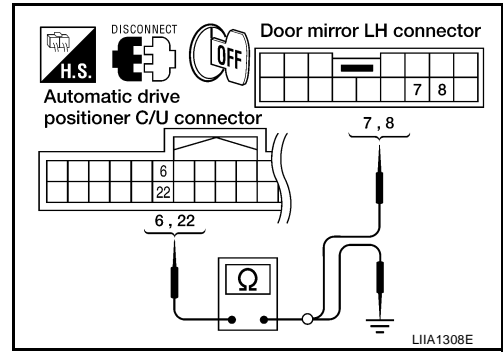

OK or NG

- OK >> Replace door mirror LH. Refer to [GW-118, "Door Mirror Assembly"](#) .
- NG >> Repair or replace harness.

Mirror Sensor RH Circuit Check

EIS004G3

1. CHECK DOOR MIRROR FUNCTION

Check the following items.

Operation malfunction in memory control

NOTE:

If a door mirror face position is set to an implausible angle, the set position may not be reproduced.

OK or NG

- OK >> GO TO 2.
- NG >> Repair the malfunctioning parts, and check the symptom again.

AUTOMATIC DRIVE POSITIONER

2. CHECK MIRROR SENSOR

With CONSULT-II

Check that "ON" is displayed on "MIR/SE RH R-L, MIR/SE RH U-D" in the DATA MONITOR.

Monitor item [OPERATION or UNIT]		Contents
MIR/SE RH R-L	"V"	Voltage output from door mirror RH sensor (LH/RH) is displayed.
MIR/SE RH U-D	"V"	Voltage output from door mirror RH sensor (UP/DOWN) is displayed.

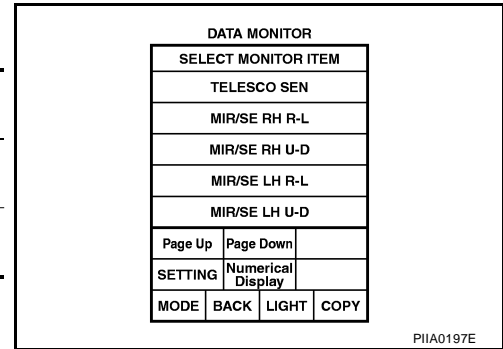

Without CONSULT-II

1. Turn ignition switch to ACC.
2. Check voltage between door mirror RH connector and ground.

Con-connector	Terminals		Condition	Voltage(V) (Approx.)
	(+)	(-)		
D107	7	Ground	Mirror motor is operated UP or DOWN	Changes between 3.4 (close to peak) – 0.6 (close to valley)
	8		Mirror motor is operated LEFT or RIGHT	Changes between 3.4 (close to left edge) – 0.6 (close to right edge)

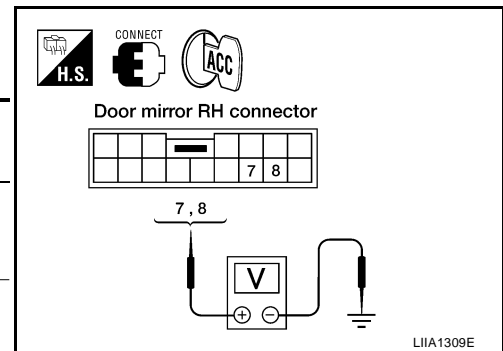

OK or NG

- OK >> Mirror sensor RH is OK.
- NG >> GO TO 3.

3. CHECK HARNESS CONTINUITY 1

1. Turn ignition switch OFF.
2. Disconnect automatic drive positioner control unit and door mirror RH.
3. Check continuity between automatic drive positioner control unit connector M34 terminals 33, 41 and door mirror RH connector D107 terminals 5, 6.

- 33 - 5 : Continuity should exist.**
- 41 - 6 : Continuity should exist.**

4. Check continuity between automatic drive positioner control unit connector M34 terminals 33, 41 and ground.

- 33 - Ground : Continuity should not exist.**
- 41 - Ground : Continuity should not exist.**

OK or NG

- OK >> GO TO 4.
- NG >> Repair or replace harness.

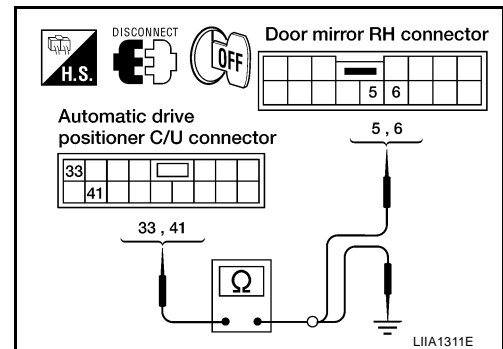

AUTOMATIC DRIVE POSITIONER

4. CHECK HARNESS CONTINUITY 2

1. Check continuity between automatic drive positioner control unit connector M33 terminals 5, 21 and door mirror RH connector D107 terminals 7, 8.

5 - 7 : Continuity should exist.

21 - 8 : Continuity should exist.

2. Check continuity between automatic drive positioner control unit connector M33 terminals 5, 21 and ground.

5 - Ground : Continuity should not exist.

21 - Ground : Continuity should not exist.

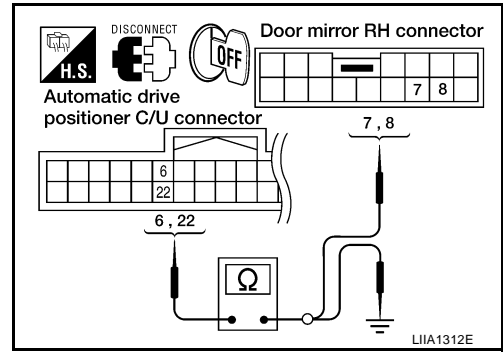

OK or NG

OK >> Replace door mirror RH. Refer to [GW-118, "Door Mirror Assembly"](#) .

NG >> Repair or replace harness.

Sliding Switch Circuit Inspection

EIS004G4

1. CHECK FUNCTION

With CONSULT-II

With "SLIDE SW-FR, SLIDE SW-RR" on the DATA MONITOR, operate the sliding switch to check ON/OFF operation.

Monitor item [OPERATION or UNIT]	Contents
SLIDE SW-FR	"ON/OFF" ON/OFF status judged from the sliding switch (FR) signal is displayed.
SLIDE SW-RR	"ON/OFF" ON/OFF status judged from the sliding switch (RR) signal is displayed.

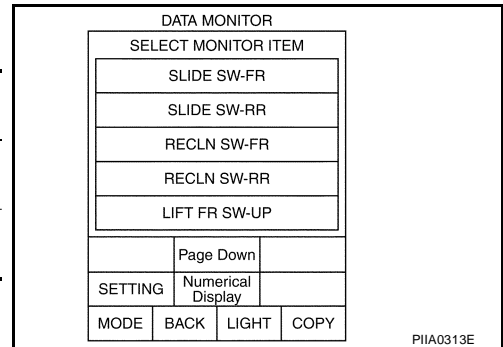

Without CONSULT-II

1. Turn ignition switch OFF.
2. Check voltage between driver seat control unit connector and ground.

Connector	Terminal		Condition	Voltage (V) (Approx.)
	(+)	(-)		
P2	11	Ground	Sliding switch ON (BACKWARD operation)	0
			Other than above	Battery voltage
	26		Sliding switch ON (FORWARD operation)	0
			Other than above	Battery voltage

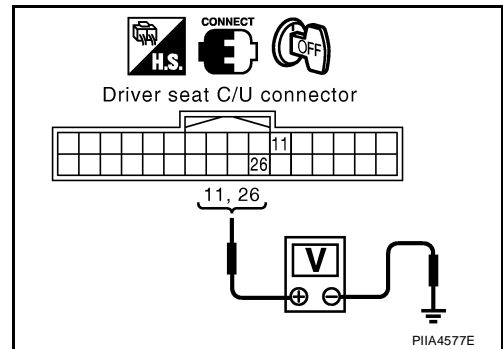

OK or NG

OK >> Sliding switch circuit is OK.

NG >> GO TO 2.

AUTOMATIC DRIVE POSITIONER

2. CHECK SLIDING SWITCH CIRCUIT HARNESS CONTINUITY

1. Disconnect driver seat control unit connector and power seat switch LH.
2. Check continuity between driver seat control unit connector P2 terminals 11, 26 and power seat switch LH connector P8 terminals 1, 7.

11 - 7 : Continuity should exist.

26 - 1 : Continuity should exist.

3. Check continuity between driver seat control unit connector P2 terminals 11, 26 and ground.

11 - Ground : Continuity should not exist.

26 - Ground : Continuity should not exist.

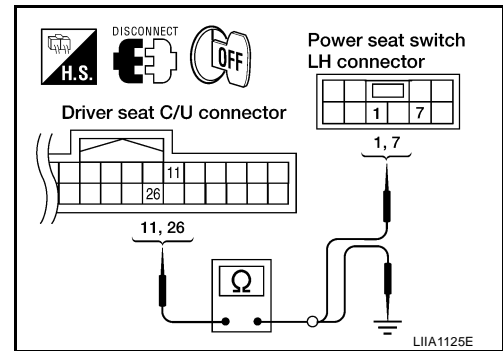

OK or NG

OK >> GO TO 3.

NG >> Repair or replace harness.

3. CHECK SLIDING SWITCH

Check continuity between power seat switch LH terminals as follows.

Terminals	Condition	Continuity
7	Sliding switch ON (BACKWARD operation)	Yes
	Other than above	No
1	Sliding switch ON (FORWARD operation)	Yes
	Other than above	No

OK or NG

OK >> Check the condition of the harness and connector.

NG >> Replace power seat switch LH. Refer to [SE-85, "Removal and Installation"](#) .

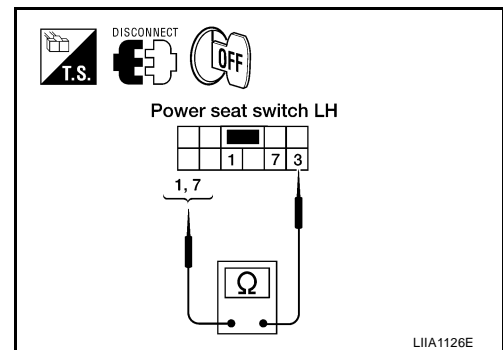

AUTOMATIC DRIVE POSITIONER

EIS004G5

Reclining Switch Inspection

1. CHECK FUNCTION

With CONSULT-II

With "RECLN SW-FR, RECLN SW-RR" on the DATA MONITOR, operate the reclining switch to check ON/OFF operation.

Monitor item [OPERATION or UNIT]		Contents
RECLN SW-FR	"ON/OFF"	ON/OFF status judged from the reclining switch (FR) signal is displayed.
RECLN SW-RR	"ON/OFF"	ON/OFF status judged from the reclining switch (RR) signal is displayed.

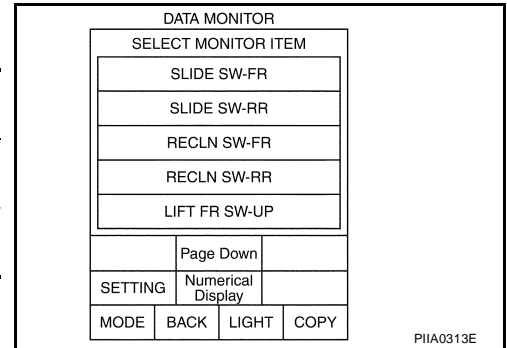

Without CONSULT-II

- Turn ignition switch OFF.
- Check voltage between driver seat control unit connector and ground.

Connector	Terminals		Condition	Voltage (V) (Approx.)
	(+)	(-)		
P2	12	Ground	Reclining switch ON (BACKWARD operation)	0
			Other than above	Battery voltage
	27		Reclining switch ON (FORWARD operation)	0
			Other than above	Battery voltage

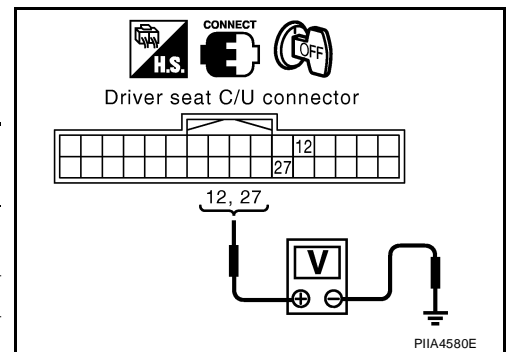

OK or NG

- OK >> Reclining switch circuit is OK.
 NG >> GO TO 2.

2. CHECK RECLINING SWITCH CIRCUIT HARNESS CONTINUITY

- Disconnect driver seat control unit and power seat switch LH.
- Check continuity between driver seat control unit connector P2 terminals 12, 27 and power seat switch LH connector P8 terminals 9, 10.

- 12 - 9** : Continuity should exist.
27 - 10 : Continuity should exist.

- Check continuity between driver seat control unit connector P2 terminals 12, 27 and ground.

- 12 - Ground** : Continuity should not exist.
27 - Ground : Continuity should not exist.

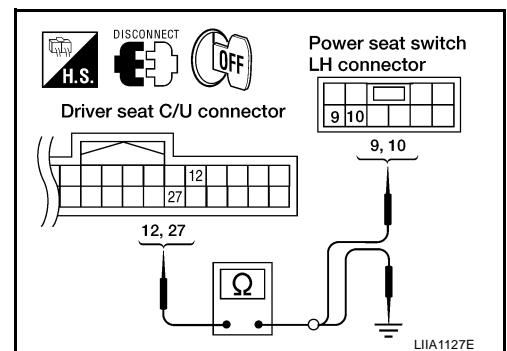

OK or NG

- OK >> GO TO 3.
 NG >> Repair or replace harness.

AUTOMATIC DRIVE POSITIONER

3. RECLINING SWITCH INSPECTION

Check continuity between power seat switch LH terminals as follows.

Terminals	Condition	Continuity
9	Reclining switch ON (BACKWARD operation)	Yes
	Other than above	No
10	Reclining switch ON (FORWARD operation)	Yes
	Other than above	No

OK or NG

OK >> Check the condition of the harness and connector.

NG >> Replace power seat switch LH. Refer to [SE-85, "Removal and Installation"](#) .

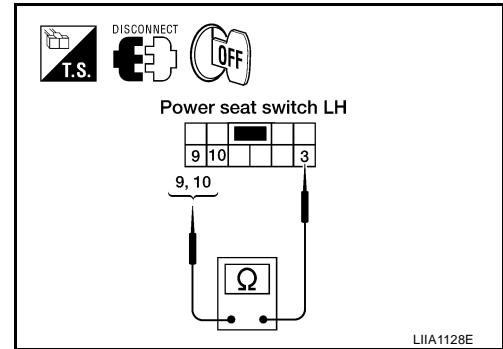

Lifting Switch (Front) Circuit Inspection

E/S004G6

1. CHECK FUNCTION

With CONSULT-II

With "LIFT FR SW-UP, LIFT FR SW-DN" on the DATA MONITOR, operate the lifting switch (front) to check ON/OFF operation.

Monitor item [OPERATION or UNIT]	Contents
LIFT FR SW-DN	"ON/OFF" ON/OFF status judged from the FR lifter switch (DOWN) signal is displayed.
LIFT RR SW-UP	"ON/OFF" ON/OFF status judged from the RR lifter switch (UP) signal is displayed.

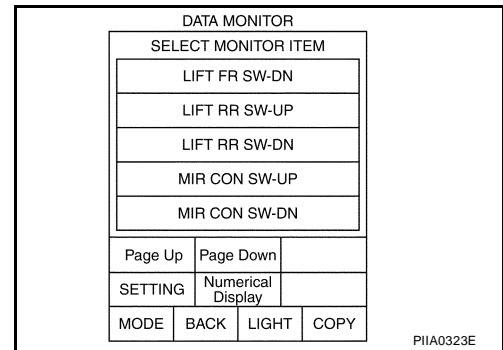

Without CONSULT-II

1. Turn ignition switch OFF.
2. Check voltage between driver seat control unit connector and ground.

Connector	Terminals		Condition	Voltage (V) (Approx.)
	(+)	(-)		
P2	13	Ground	Lifting switch (front) ON (DOWN operation)	0
			Other than above	Battery voltage
	28		Lifting switch (front) ON (UP operation)	0
			Other than above	Battery voltage

OK or NG

OK >> Lifting switch (front) circuit is OK.

NG >> GO TO 2.

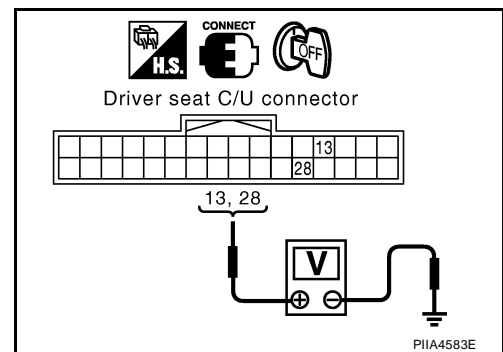

AUTOMATIC DRIVE POSITIONER

2. CHECK LIFTING SWITCH (FRONT) CIRCUIT HARNESS CONTINUITY

1. Disconnect driver seat control unit and power seat switch LH.
2. Check continuity between driver seat control unit connector P2 terminals 13, 28 and power seat switch LH connector P2 terminals 5, 6.

13 - 5 : Continuity should exist.

28 - 6 : Continuity should exist.

3. Check continuity between driver seat control unit connector P2 terminals 13, 28 and ground.

13 - Ground : Continuity should not exist.

28 - Ground : Continuity should not exist.

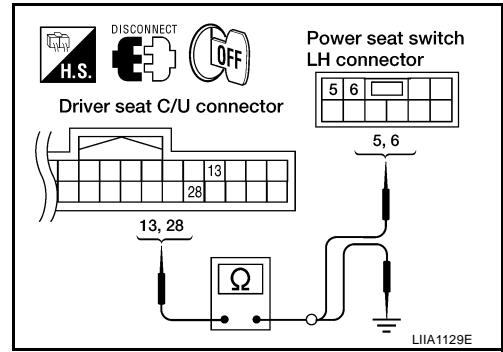

OK or NG

OK >> GO TO 3.

NG >> Repair or replace harness.

3. CHECK LIFTING SWITCH (FRONT)

Check continuity between power seat switch LH terminals as follows.

Terminals	Condition	Continuity
5	Lifting switch (front) ON (DOWN operation)	Yes
	Other than above	No
6	Lifting switch (front) ON (UP operation)	Yes
	Other than above	No

OK or NG

OK >> Check the condition of the harness and connector.

NG >> Replace power seat switch LH. Refer to [SE-85, "Removal and Installation"](#) .

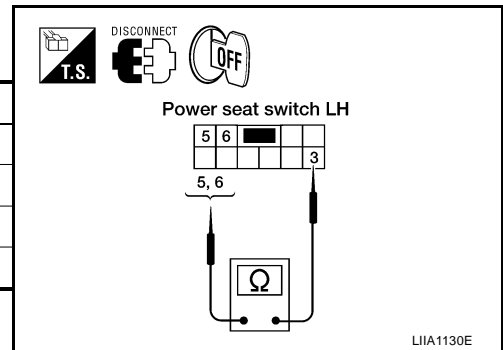

AUTOMATIC DRIVE POSITIONER

EIS004G7

Lifting Switch (Rear) Circuit Inspection

1. CHECK FUNCTION

With CONSULT-II

With "LIFT RR SW-UP, LIFT RR SW-DN" on the DATA MONITOR, operate the rear lifting switch to check ON/OFF operation.

Monitor item [OPERATION or UNIT]		Contents
LIFT RR SW-UP	"ON/OFF"	Operation (ON)/open (OFF) status judged from the RR lifter switch (UP) signal is displayed.
LIFT RR SW-DN	"ON/OFF"	Operation (ON)/open (OFF) status judged from the RR lifter switch (DOWN) signal is displayed.

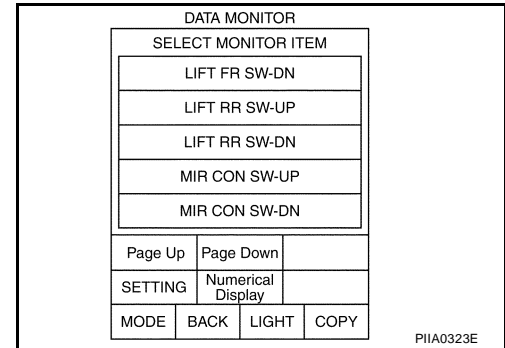

Without CONSULT-II

1. Turn ignition switch OFF.
2. Check voltage between driver seat control unit connector and ground.

Connector	Terminals		Condition	Voltage (V) (Approx.)
	(+)	(-)		
P2	14	Ground	Lifting switch (rear) ON (DOWN operation)	0
			Other than above	Battery voltage
	29		Lifting switch (rear) ON (UP operation)	0
			Other than above	Battery voltage

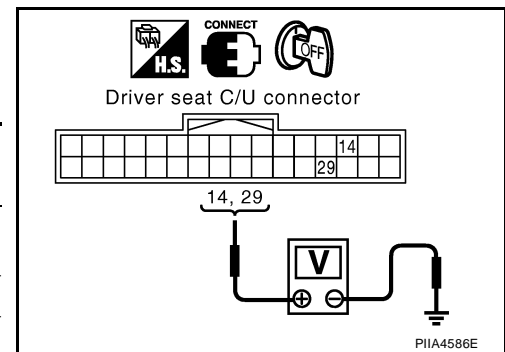

OK or NG

- OK >> Lifting switch (rear) circuit is OK.
 NG >> GO TO 2.

2. CHECK LIFTING SWITCH (REAR) CIRCUIT HARNESS CONTINUITY

1. Disconnect driver seat control unit and power seat switch LH.
2. Check continuity between driver seat control unit connector P2 terminals 14, 29 and power seat switch connector P8 terminals 2, 8.

14 - 8 : Continuity should exist.
29 - 2 : Continuity should exist.

3. Check continuity between driver seat control unit connector P2 terminals 14, 29 and ground.

14 - Ground : Continuity should not exist.
29 - Ground : Continuity should not exist.

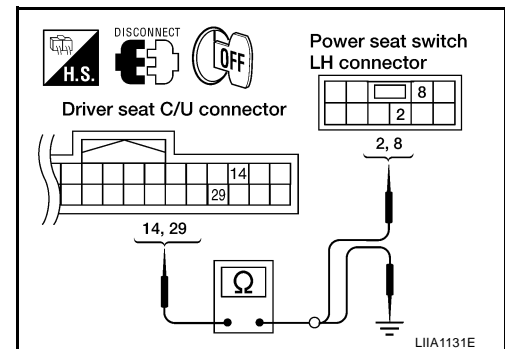

OK or NG

- OK >> GO TO 3.
 NG >> Repair or replace harness.

AUTOMATIC DRIVE POSITIONER

3. CHECK LIFTING SWITCH (REAR)

Check continuity between power seat switch LH terminals as follows.

Terminals	Condition	Continuity
8	Lifting switch (rear) ON (DOWN operation)	Yes
	Other than above	No
2	Lifting switch (rear) ON (UP operation)	Yes
	Other than above	No

OK or NG

OK >> Check the condition of the harness and connector.

NG >> Replace power seat switch LH. Refer to [SE-85, "Removal and Installation"](#) .

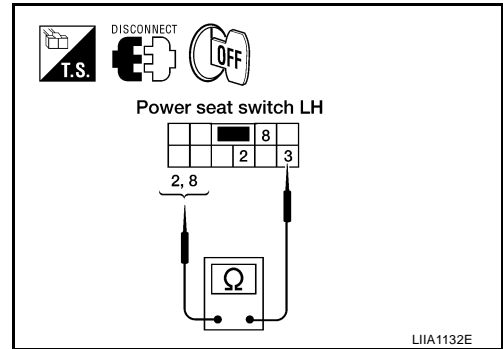

Power Seat Switch Ground Inspection

E/S004G8

1. CHECK POWER SEAT SWITCH GROUND CIRCUIT

1. Turn ignition switch OFF.
2. Disconnect power seat switch LH.
3. Check continuity between power seat switch LH connector P8 terminal 3 and ground.

3 - Ground : Continuity should exist.

OK or NG

OK >> Check the condition of the harness and connector.

NG >> Repair or replace harness.

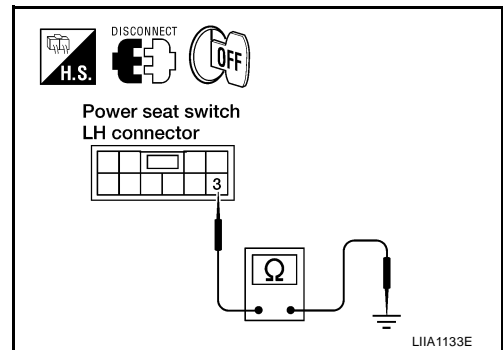

AUTOMATIC DRIVE POSITIONER

EIS004G9

Pedal Adjusting Switch Circuit Inspection

1. CHECK FUNCTION

④ With CONSULT-II

With "PEDAL SW-FR, PEDAL SW-RR" on the DATA MONITOR, operate the pedal adjusting switch to check ON/OFF operation.

Monitor item [OPERATION or UNIT]		Contents
PEDAL SW-FR	"ON/OFF"	Operation (ON)/open (OFF) status judged from the pedal adjusting switch (FR) signal is displayed.
PEDAL SW-RR	"ON/OFF"	Operation (ON)/open (OFF) status judged from the pedal adjusting switch (RR) signal is displayed.

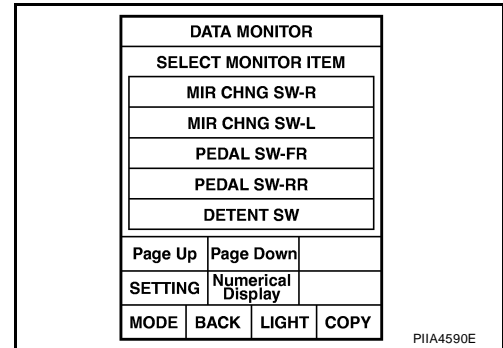

⊗ Without CONSULT-II

1. Turn ignition switch OFF.
2. Check voltage between driver seat control unit connector and ground.

Connector	Terminals		Condition	Voltage (V) (Approx.)
	(+)	(-)		
P2	15	Ground	Pedal adjusting switch ON (BACKWARD operation)	0
			Other than above	Battery voltage
	30		Pedal adjusting switch ON (FORWARD operation)	0
			Other than above	Battery voltage

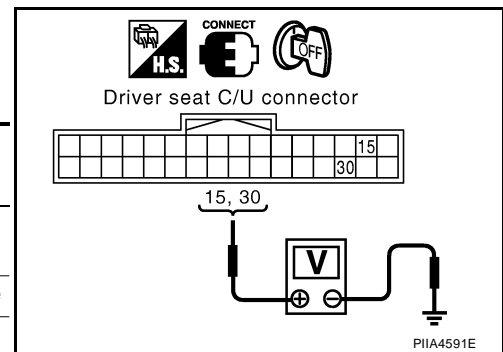

OK or NG

- OK >> Pedal adjusting switch circuit is OK.
 NG >> GO TO 2.

2. CHECK PEDAL ADJUSTING SWITCH CIRCUIT HARNESS CONTINUITY

1. Disconnect driver seat control unit and pedal adjusting switch.
2. Check continuity between driver seat control unit connector P2 terminals 15, 30 and pedal adjusting switch connector M96 terminals 2, 3.

- 15 - 2 : Continuity should exist.**
30 - 3 : Continuity should exist.

3. Check continuity between driver seat control unit connector P2 terminals 15, 30 and ground.

- 15 - Ground : Continuity should not exist.**
30 - Ground : Continuity should not exist.

OK or NG

- OK >> GO TO 3.
 NG >> Repair or replace harness.

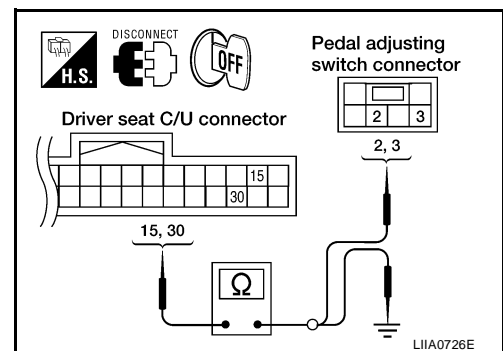

AUTOMATIC DRIVE POSITIONER

3. CHECK PEDAL ADJUSTING SWITCH

Check continuity between pedal adjusting switch terminals as follows.

Terminals	Condition	Continuity
2	Pedal adjusting switch ON (BACWARD operation)	Yes
	Other than above	No
3	Pedal adjusting switch ON (FORWARD operation)	Yes
	Other than above	No

OK or NG

OK >> GO TO 4.

NG >> Replace pedal adjusting switch. Refer to [IP-10, "INSTRUMENT PANEL ASSEMBLY"](#) .

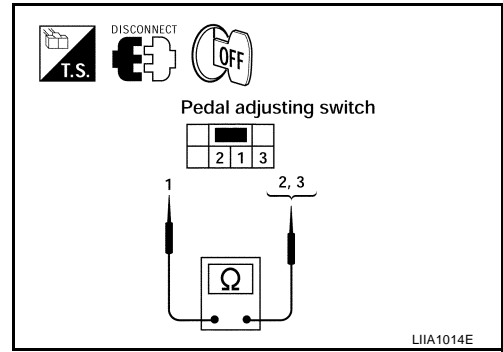

4. CHECK PEDAL ADJUSTING SWITCH GROUND CIRCUIT

Check continuity between pedal adjusting switch connector M96 terminal 1 and ground.

1 - Ground : Continuity should exist.

OK or NG

OK >> Check the condition of the harness and connector.

NG >> Repair or replace harness.

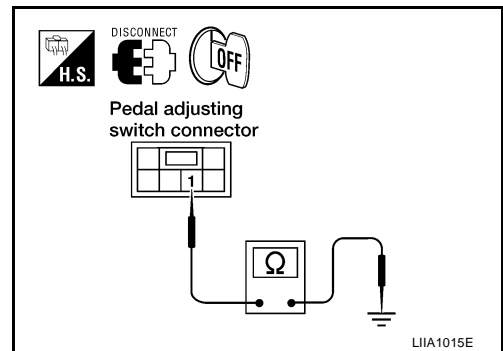

A
B
C
D
E
F
G
H
SE
J
K
L
M

AUTOMATIC DRIVE POSITIONER

Door Mirror Remote Control Switch (Changeover Switch) Circuit Check

EIS004GA

1. CHECK FUNCTION

With CONSULT-II

Check the operation on "MIR CHNG SW-R" or "MIR CHNG SW-L" in the DATA MONITOR.

Monitor item [OPERATION or UNIT]	Contents
MIR CHNG SW-R	"ON/OFF" ON/OFF status judged from the changeover switch (switching to RIGHT) signal is displayed.
MIR CHNG SW-L	"ON/OFF" ON/OFF status judged from the changeover switch (switching to LEFT) signal is displayed.

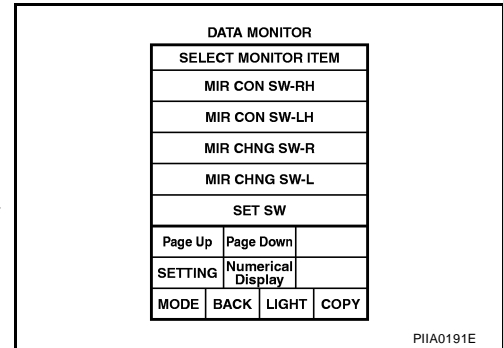

Without CONSULT-II

1. Turn ignition switch to ACC.
2. Check voltage between automatic drive positioner control unit connector and ground.

Connector	Terminals		Condition	Voltage (V) (Approx.)
	(+)	(-)		
M33	2	Ground	Changeover switch RIGHT position	0
			Other than above	5
	18		Changeover switch LEFT position	0
			Other than above	5

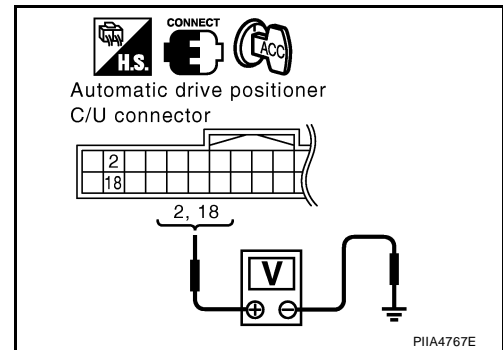

OK or NG

- OK >> Door mirror remote control switch (changeover switch) is OK.
- NG >> GO TO 2.

2. CHECK DOOR MIRROR REMOTE CONTROL SWITCH CIRCUIT HARNESS CONTINUITY

1. Turn ignition switch OFF.
2. Disconnect automatic drive positioner control unit and door mirror remote control switch.
3. Check continuity between automatic drive positioner control unit connector M33 terminals 2, 18 and door mirror remote control switch connector D10 terminals 2, 3.

2 - 3 : Continuity should exist.
18 - 2 : Continuity should exist.

4. Check continuity between automatic drive positioner control unit connector M33 terminals 2, 18 and ground.

2 - Ground : Continuity should not exist.
18 - Ground : Continuity should not exist.

OK or NG

- OK >> GO TO 3.
- NG >> Repair or replace harness.

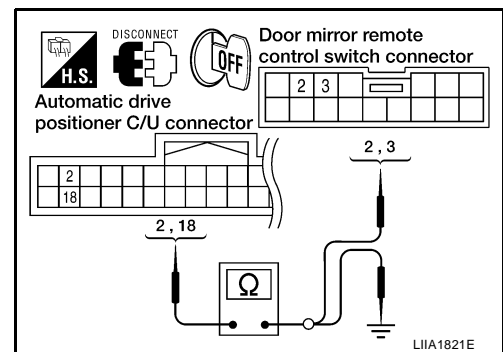

AUTOMATIC DRIVE POSITIONER

3. CHECK DOOR MIRROR REMOTE CONTROL SWITCH (CHANGEOVER SWITCH)

Check continuity between door mirror remote control switch terminals as follows.

Terminals	Condition	Continuity
3	Changeover switch RIGHT position	Yes
	Other than above	No
2	Changeover switch LEFT position	Yes
	Other than above	No

OK or NG

- OK >> Check the condition of the harness and the connector.
- NG >> Replace door mirror remote control switch.

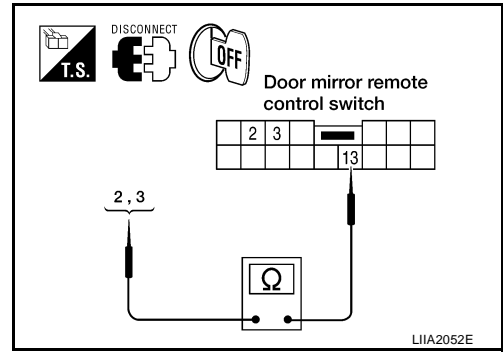

Door Mirror Remote Control Switch (Mirror Switch) Circuit Check

EIS004GB

1. CHECK DOOR MIRROR REMOTE CONTROL SWITCH (MIRROR SWITCH) SIGNAL

With CONSULT-II

Check the operation on "MIR CON SW-UP/DN" and "MIR CON SW-RH/LH" in the DATA MONITOR.

Monitor item [OPERATION or UNIT]	Contents
MIR CON SW-UP	"ON/OFF" ON/OFF status judged from the mirror switch (UP) signal is displayed.
MIR CON SW-DN	"ON/OFF" ON/OFF status judged from the mirror switch (DOWN) signal is displayed.
MIR CON SW-RH	"ON/OFF" ON/OFF status judged from the mirror switch (RIGHT) signal is displayed.
MIR CON SW-LH	"ON/OFF" ON/OFF status judged from the mirror switch (LEFT) signal is displayed.

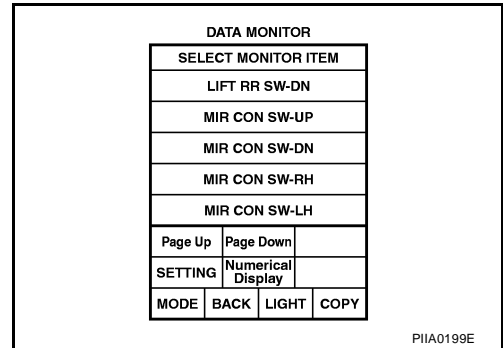

Without CONSULT-II

- Turn ignition switch to ACC.
- Check voltage between automatic drive positioner control unit connector and ground.

Connector	Terminals		Condition	Voltage (V) (Approx.)
	(+)	(-)		
M33	3	Ground	Mirror switch UP operation	0
			Other than above	5
	4		Mirror switch LEFT operation	0
			Other than above	5
	19		Mirror switch DOWN operation	0
			Other than above	5
	20		Mirror switch RIGHT operation	0
			Other than above	5

OK or NG

- OK >> Door mirror remote control switch (mirror switch) circuit is OK.
- NG >> GO TO 2.

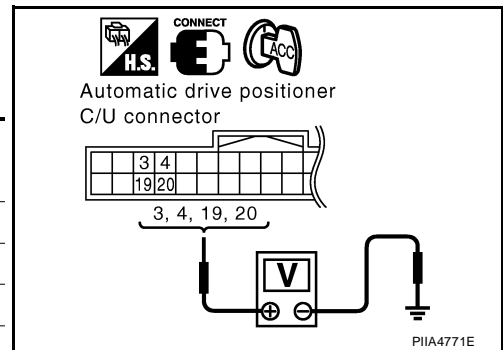

AUTOMATIC DRIVE POSITIONER

2. CHECK HARNESS CONTINUITY

1. Turn ignition switch OFF.
2. Disconnect automatic drive positioner control unit and door mirror remote control switch.
3. Check continuity between automatic drive positioner control unit connector M33 terminals 3, 4, 19, 20 and door mirror remote control switch connector D10 terminals 4, 5, 6, 14.

- 3 - 6 : Continuity should exist.**
- 4 - 5 : Continuity should exist.**
- 19 - 14 : Continuity should exist.**
- 20 - 4 : Continuity should exist.**

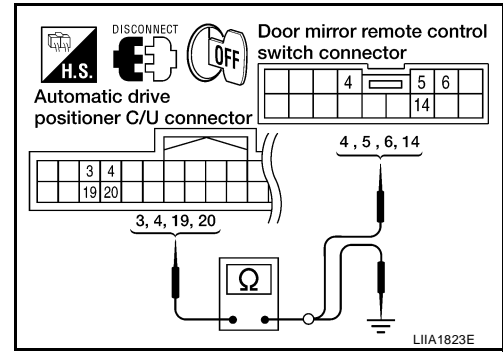

4. Check continuity between automatic drive positioner control unit connector M33 terminals 3, 4, 19, 20 and ground.

- 3 - Ground : Continuity should not exist.**
- 4 - Ground : Continuity should not exist.**
- 19 - Ground : Continuity should not exist.**
- 20 - Ground : Continuity should not exist.**

OK or NG

- OK >> GO TO 3.
- NG >> Repair or replace harness.

3. CHECK DOOR MIRROR REMOTE CONTROL SWITCH (MIRROR SWITCH)

Check continuity between door mirror remote control switch terminals as follows.

Terminals	Switch condition	Continuity
4	Mirror switch RIGHT operation	Yes
	Other than above	No
5	Mirror switch LEFT operation	Yes
	Other than above	No
6	Mirror switch UP operation	Yes
	Other than above	No
14	Mirror switch DOWN operation	Yes
	Other than above	No

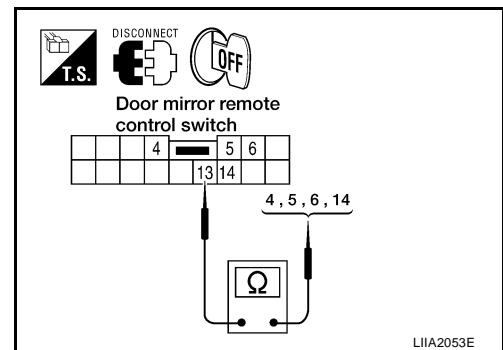

OK or NG

- OK >> Check the condition of the harness and connector.
- NG >> Replace door mirror remote control switch.

AUTOMATIC DRIVE POSITIONER

EIS004GC

Door Mirror Remote Control Switch Ground Circuit Inspection

1. CHECK DOOR MIRROR REMOTE CONTROL SWITCH GROUND CIRCUIT

1. Turn ignition switch OFF.
2. Disconnect door mirror remote control switch.
3. Check continuity between door mirror remote control switch connector D10 terminal 7 and ground.

13 - Ground : Continuity should exist.

OK or NG

- OK >> GO TO 2.
 NG >> Repair or replace harness.

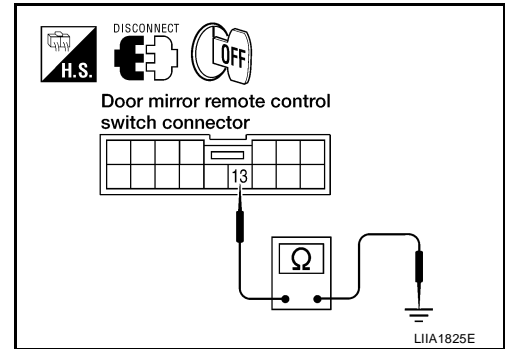

2. CHECK DOOR MIRROR REMOTE CONTROL SWITCH (CHANGEOVER SWITCH)

Check continuity between door mirror remote control switch terminals as follows.

Terminals	Condition	Continuity
3	Changeover switch RIGHT position	Yes
	Other than above	No
2	Changeover switch LEFT position	Yes
	Other than above	No

OK or NG

- OK >> Check the condition of the harness and the connector.
 NG >> Replace door mirror remote control switch.

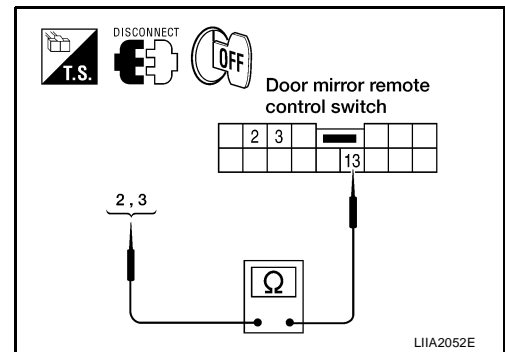

Seat Memory Switch Circuit Inspection

EIS004GD

1. CHECK FUNCTION

With CONSULT-II

With "SET SW, MEMORY SW 1, MEMORY SW 2" on the DATA MONITOR, operate the switch to check ON/OFF operation.

Monitor item [OPERATION or UNIT]	Contents
MEMORY SW 1 "ON/OFF"	ON/OFF status judged from the seat memory switch 1 signal is displayed.
MEMORY SW 2 "ON/OFF"	ON/OFF status judged from the seat memory switch 2 signal is displayed.
SET SW "ON/OFF"	ON/OFF status judged from the setting switch signal is displayed.

Without CONSULT-II

GO TO 2.

OK or NG

- OK >> Seat memory switch circuit is OK.
 NG >> GO TO 2.

DATA MONITOR

MONITOR		
SLIDE SW-FR	OFF	
SLIDE SW-RR	OFF	
RECLN SW-FR	OFF	
RECLN SW-RR	OFF	
LIFT FR SW-UP	OFF	
LIFT FR SW-DN	OFF	
LIFT RR SW-UP	OFF	
LIFT RR SW-DN	OFF	
SET SW	OFF	

Page Down

RECORD

MODE	BACK	LIGHT	COPY
------	------	-------	------

DATA MONITOR

MONITOR		
TELESCO SW-FR	OFF	
TELESCO SW-RR	OFF	
TILT SW-UP	OFF	
TILT SW-DOWN	OFF	
MEMORY SW 1	OFF	
MEMORY SW 2	OFF	
CANCEL SW	OFF	
DOOR SW-DR	OFF	
VHCL SPEED SE	<7km/	

Page Up Page Down

RECORD

MODE	BACK	LIGHT	COPY
------	------	-------	------

PIIA0309E

AUTOMATIC DRIVE POSITIONER

2. CHECK SEAT MEMORY SWITCH

1. Turn ignition switch OFF.
2. Disconnect seat memory switch.
3. Operate the setting switch and seat memory switch.
4. Check continuity between seat memory switch as follows.

Terminal	Condition	Continuity
1	Memory switch 1 ON	Yes
	Memory switch 1: OFF	No
2	Memory switch 2: ON	Yes
	Memory switch 2: OFF	No
3	Set switch: ON	Yes
	Set switch: OFF	No

OK or NG

- OK >> GO TO 3.
 NG >> Replace seat memory switch.

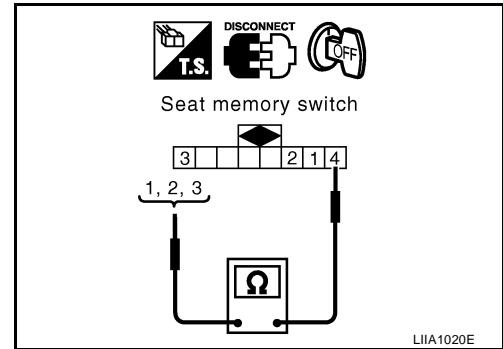

3. CHECK HARNESS CONTINUITY

1. Disconnect automatic drive positioner control unit.
2. Check continuity between automatic drive positioner control unit connector M33 terminals 9, 24, 25 and seat memory switch connector D5 terminals 1, 2, 3.

- 9 - 1 : Continuity should exist.**
24 - 3 : Continuity should exist.
25 - 2 : Continuity should exist.

3. Check continuity between automatic drive positioner control unit connector M33 terminals 9, 24, 25 and ground.

- 9 - Ground : Continuity should not exist.**
24 - Ground : Continuity should not exist.
25 - Ground : Continuity should not exist.

OK or NG

- OK >> GO TO 4.
 NG >> Repair or replace harness.

4. CHECK SEAT MEMORY SWITCH GROUND CIRCUIT

Check continuity between seat memory switch D5 terminal 4 and ground.

- 4 - Ground : Continuity should exist.**

OK or NG

- OK >> Replace automatic drive positioner control unit.
 NG >> Repair or replace harness.

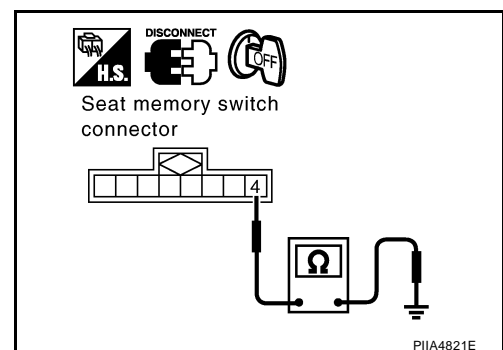
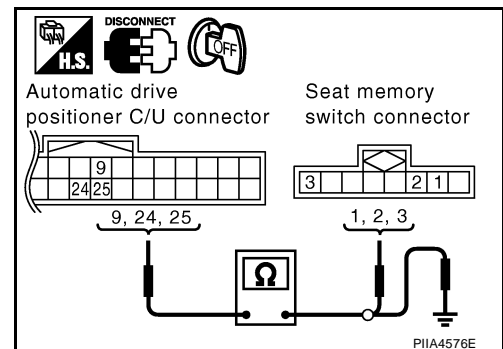

AUTOMATIC DRIVE POSITIONER

EIS004GE

Seat Memory Indicator Lamp Circuit Inspection

1. CHECK FUNCTION

With CONSULT-II

With "MEMORY SW INDCTR" in ACTIVE TEST, check operation.

Test item	Description
MEMORY SW INDCTR	The memory switch indicator is lit by receiving the drive signal.

Without CONSULT-II

GO TO 2.

OK or NG

- OK >> Seat memory switch indicator lamp circuit is OK.
 NG >> GO TO 2.

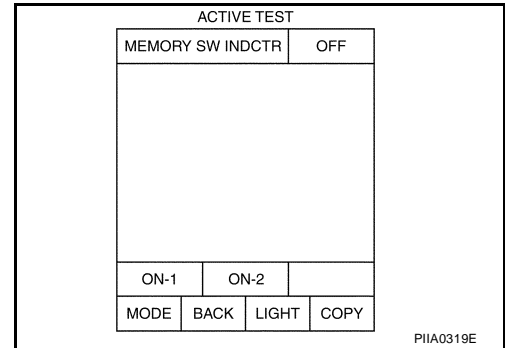

2. CHECK SEAT MEMORY SWITCH POWER SUPPLY CIRCUIT

- Turn ignition switch OFF.
- Disconnect seat memory switch.
- Check voltage between seat memory switch connector D5 terminal 5 and ground.

5 - Ground : Battery voltage

OK or NG

- OK >> GO TO 3.
 NG >> Repair or replace harness.

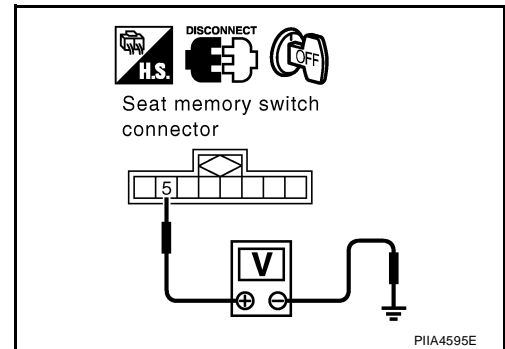

3. CHECK SEAT MEMORY INDICATOR CIRCUIT HARNESS CONTINUITY

- Turn ignition switch OFF.
- Disconnect automatic drive positioner control unit.
- Check continuity between automatic drive positioner control unit connector M33 terminals 12, 13 and seat memory switch connector D5 terminals 6, 7.

12 - 6 : Continuity should exist.

13 - 7 : Continuity should exist.

- Check continuity between automatic drive positioner control unit connector M33 terminals 12, 13 and ground.

12 - Ground : Continuity should not exist.

13 - Ground : Continuity should not exist.

OK or NG

- OK >> GO TO 4.
 NG >> Repair or replace harness.

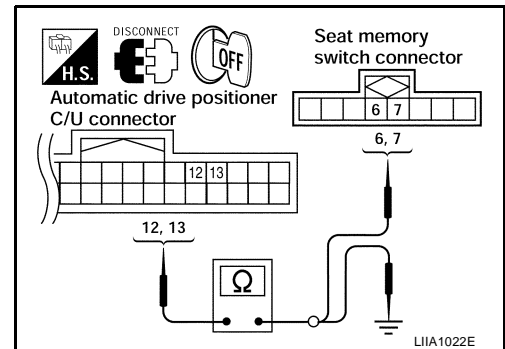

AUTOMATIC DRIVE POSITIONER

4. CHECK SEAT MEMORY SWITCH INDICATOR SIGNAL

1. Connect seat memory switch.
2. Turn ignition switch ON.
3. Check voltage between automatic drive positioner control unit connector M33 terminals 12, 13 and ground.

12 - Ground : Battery voltage

13 - Ground : Battery voltage

OK or NG

OK >> Replace automatic drive positioner control unit.

NG >> Replace seat memory switch.

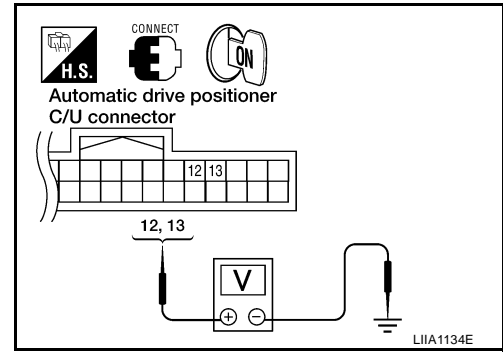

Door Mirror Sensor Power Supply and Ground Circuit inspection

EIS004GF

1. CHECK DOOR MIRROR SENSOR CIRCUIT HARNESS CONTINUITY

1. Turn ignition switch OFF.
2. Disconnect automatic drive positioner control unit.
3. Check continuity between automatic drive positioner control unit connector M34 terminals 33, 41 and door mirror connector D4 (LH), D107 (RH) terminals 5, 6.

33 - 5 : Continuity should exist.

41 - 6 : Continuity should exist.

4. Check continuity between automatic drive positioner control unit connector M34 terminals 33, 41 and ground.

33 - Ground : Continuity should not exist.

41 - Ground : Continuity should not exist.

OK or NG

OK >> GO TO 2.

NG >> Repair or replace harness.

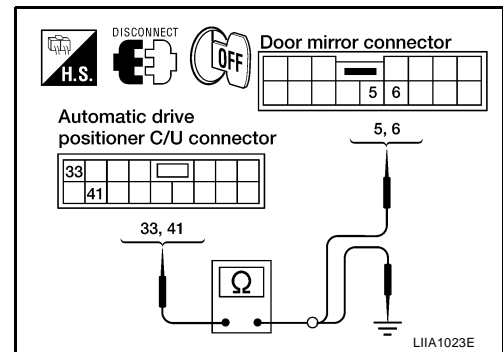

2. CHECK MIRROR SENSOR POWER SUPPLY

1. Connect automatic drive positioner control unit and door mirror LH.
2. Turn ignition switch to ACC.
3. Check voltage between automatic drive positioner control unit connector M34 terminal 33 and ground.

33 - Ground : Approx. 5V

OK or NG

OK >> GO TO 3.

NG >> Replace automatic drive positioner control unit.

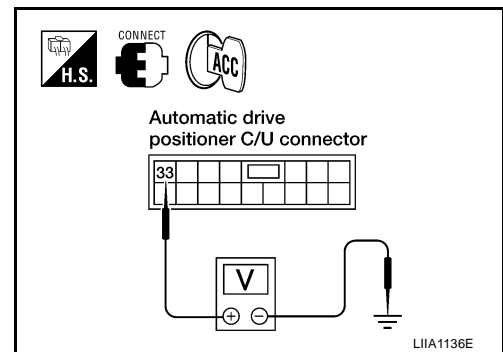

AUTOMATIC DRIVE POSITIONER

3. CHECK MIRROR SENSOR GROUND CIRCUIT

1. Turn ignition switch OFF.
2. Check continuity between automatic drive positioner control unit connector M34 terminal 41 and ground.

41 - Ground : Continuity should exist.

OK or NG

- OK >> Check the condition of the harness and connector.
 NG >> Replace automatic drive positioner control unit.

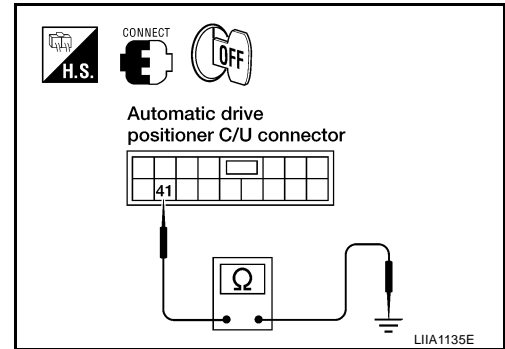

A/T Device (Park Position Switch) Circuit Inspection (Floor Shift)

EIS004GG

1. CHECK FUNCTION

With CONSULT-II

Check that when the A/T selector lever is in P position, "DETENT SW" on the DATA MONITOR becomes OFF.

Monitor item [OPERATION or UNIT]	Contents	
DETENT SW	"ON/ OFF"	The A/T selector lever position "P position (OFF)/other than P position (ON)" judged from the park position switch signal is displayed.

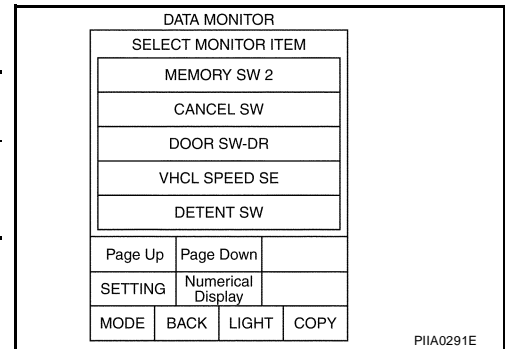

Without CONSULT-II

GO TO 2.

OK or NG

- OK >> A/T device (park position switch) circuit is OK.
 NG >> GO TO 2.

2. CHECK A/T DEVICE (PARK POSITION SWITCH) HARNESS

1. Turn ignition switch OFF.
2. Disconnect A/T device and driver seat control unit.
3. Check continuity between A/T device connector M203 terminal 6 and driver seat control unit connector P2 terminal 21.

6 - 21 : Continuity should exist.

4. Check continuity between A/T device connector M203 terminal 6 and ground.

6 - Ground : Continuity should not exist.

OK or NG

- OK >> GO TO 3.
 NG >> Repair or replace harness.

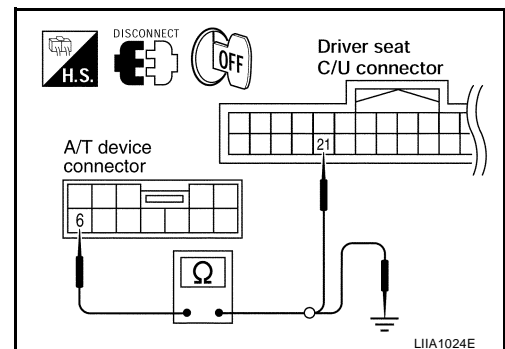

AUTOMATIC DRIVE POSITIONER

3. CHECK A/T DEVICE

Check continuity between A/T device (park position switch) terminals as follows.

Terminals		Condition	Continuity
5	6	P position	No
		Other than P position	Yes

OK or NG

- OK >> A/T device is OK.
- NG >> Replace A/T device.

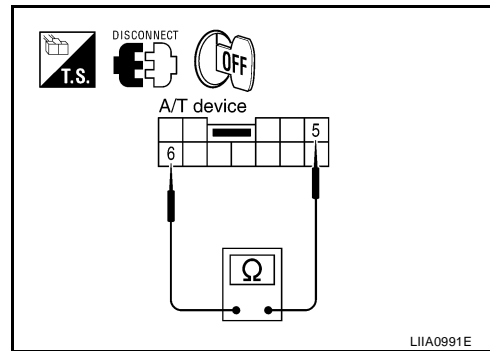

LIA0991E

A/T Device (Park Position Switch) Circuit Inspection (Column Shift)

EIS0062J

1. CHECK FUNCTION

Ⓟ With CONSULT-II

Check that when the A/T selector lever is in P position, "DETENT SW" on the DATA MONITOR becomes OFF.

Monitor item [OPERATION or UNIT]		Contents
DETENT SW	"ON/OFF"	The A/T selector lever position "P position (OFF)/other than P position (ON)" judged from the park position switch signal is displayed.

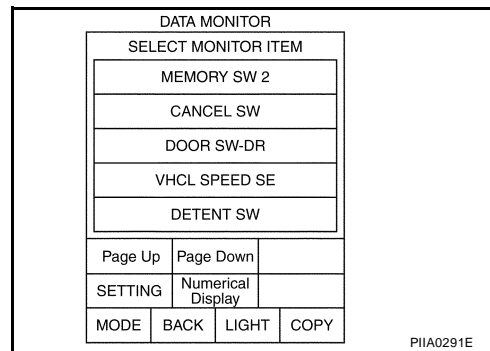

PIIA0991E

ⓧ Without CONSULT-II

GO TO 2.

OK or NG

- OK >> A/T device (park position switch) circuit is OK.
- NG >> GO TO 2.

2. CHECK A/T DEVICE (PARK POSITION SWITCH) HARNESS

1. Turn ignition switch OFF.
2. Disconnect A/T device and driver seat control unit.
3. Check continuity between A/T device connector M68 terminal 8 and driver seat control unit connector P2 terminal 21.

8 - 21 : Continuity should exist.

4. Check continuity between driver seat control unit connector P2 terminal 21 and ground.

21 - Ground : Continuity should not exist.

OK or NG

- OK >> GO TO 3.
- NG >> Repair or replace harness.

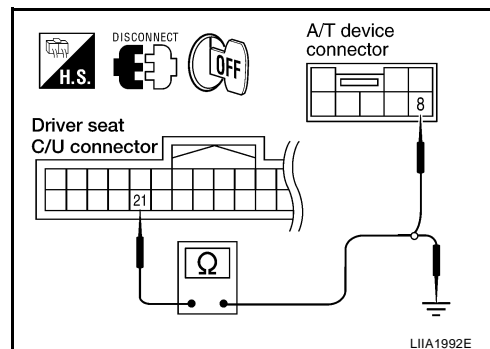

LIA1992E

AUTOMATIC DRIVE POSITIONER

3. CHECK A/T DEVICE

Check continuity between A/T device (park position switch) as follows.

Terminals		Condition	Continuity
1	8	P position	No
		Other than P position	Yes

OK or NG

- OK >> A/T device is OK.
- NG >> Replace A/T device.

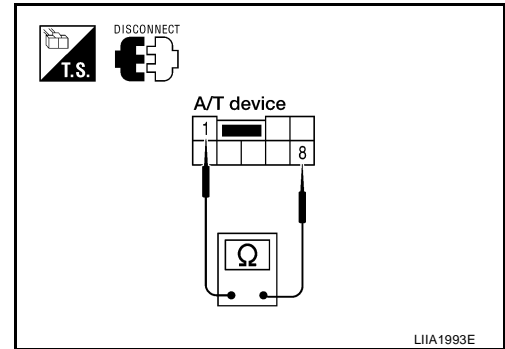

Front Door Switch LH Circuit Inspection (King Cab)

EIS004GH

1. CHECK FUNCTION

With CONSULT-II

Touch "BCM" with "DOOR SW DR" on the DATA MONITOR, check ON/OFF operation when the front door is open and closed.

Monitor item [OPERATION or UNIT]	Contents	
DOOR SW DR*	"ON/OFF"	Door open (ON)/door closed (OFF) status judged from the front door switch is displayed.

*:Refer to [SE-34, "DATA MONITOR"](#) .

Without CONSULT-II

GO TO 2.

OK or NG

- OK >> Front door switch LH circuit is OK.
- NG >> GO TO 2.

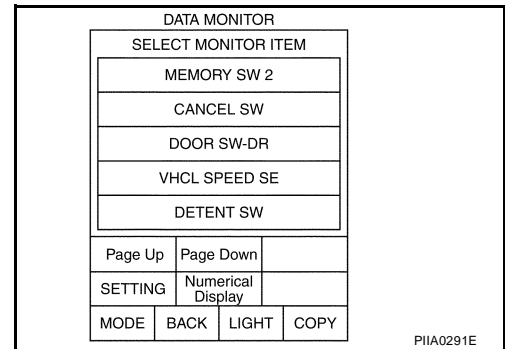

2. CHECK FRONT DOOR SWITCH LH

1. Turn ignition switch OFF.
2. Disconnect front door switch LH.
3. Check continuity between front door switch LH terminals 2 and 3.

Terminals		Condition	Continuity
2	3	With the front door switch LH pressed	No
		With the front door switch LH released	Yes

OK or NG

- OK >> GO TO 3.
- NG >> Replace front door switch LH.

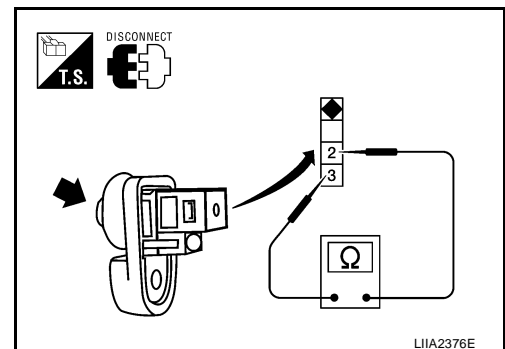

AUTOMATIC DRIVE POSITIONER

3. CHECK HARNESS CONTINUITY

1. Disconnect BCM.
2. Check continuity between BCM connector M19 terminal 47 and front door switch LH connector B8 terminal 2.

47 - 2 : Continuity should exist.

3. Check continuity between BCM connector M19 terminal 47 and ground.

47 - Ground : Continuity should not exist.

OK or NG

- OK >> Front door switch LH circuit is OK.
- NG >> Repair or replace harness.

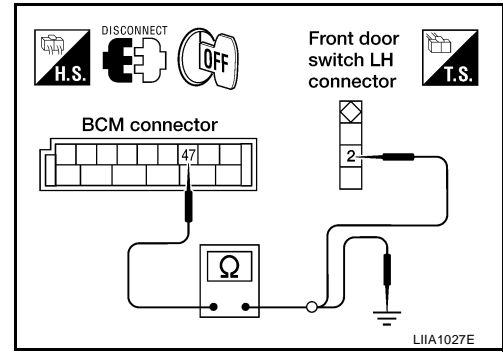

Front Door Switch LH Circuit Inspection (Crew Cab)

EIS007YE

1. CHECK FUNCTION

Ⓜ With CONSULT-II

Touch "BCM" with "DOOR SW DR" on the DATA MONITOR, check ON/OFF operation when the front door is open and closed.

Monitor item [OPERATION or UNIT]	Contents
DOOR SW DR*	"ON/OFF" Door open (ON)/door closed (OFF) status judged from the front door switch is displayed.

*:Refer to SE-34, "DATA MONITOR" .

ⓧ Without CONSULT-II

GO TO 2.

OK or NG

- OK >> Front door switch LH circuit is OK.
- NG >> GO TO 2.

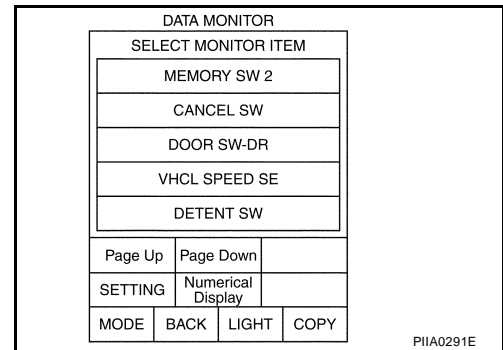

2. CHECK FRONT DOOR SWITCH LH

1. Turn ignition switch OFF.
2. Disconnect front door switch LH.
3. Check continuity between front door switch LH terminal 2 and body ground part of front door switch.

Terminals	Condition	Continuity
2	Ground	With the front door switch LH pressed No
		With the front door switch LH released Yes

OK or NG

- OK >> GO TO 3.
- NG >> Replace front door switch LH.

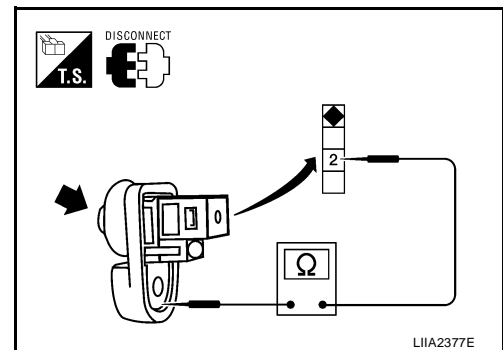

AUTOMATIC DRIVE POSITIONER

3. CHECK HARNESS CONTINUITY

1. Disconnect BCM.
2. Check continuity between BCM connector M19 terminal 47 and front door switch LH connector B8 terminal 2.

47 - 2 : Continuity should exist.

3. Check continuity between BCM connector M19 terminal 47 and ground.

47 - Ground : Continuity should not exist.

OK or NG

- OK >> Front door switch LH circuit is OK.
 NG >> Repair or replace harness.

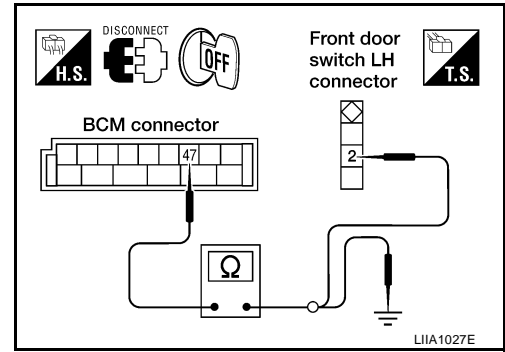

UART Communication Line Circuit Inspection

E/IS004GI

1. CHECK UART LINE INPUT/OUTPUT SIGNAL 1

1. Turn ignition switch OFF.
2. Check signal between driver seat control unit connector and ground, with oscilloscope.

Connector	Terminals		Condition	Signal
	(+)	(-)		
P2	17	Ground	Pedal adjusting switch ON (FORWARD or BACKWARD operation)	

PIIA4814E

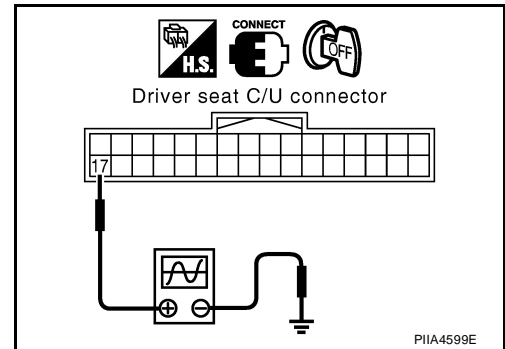

PIIA4599E

OK or NG

- OK >> GO TO 2.
 NG >> Check the following.
- When voltage wave form does not appear with a constant voltage (approx. 5V), replace driver seat control unit.
 - When voltage wave form does not appear with a constant voltage (approx. 0V), replace automatic driver seat control unit.

AUTOMATIC DRIVE POSITIONER

2. CHECK UART LINE INPUT/OUTPUT SIGNAL 2

Check signal between automatic drive positioner control unit connector ground, with oscilloscope.

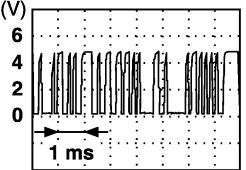
Connector	Terminals		Condition	Signal
	(+)	(-)		
M33	10	Ground	Pedal adjusting switch ON (FORWARD or BACKWARD operation)	 PIIA4813E

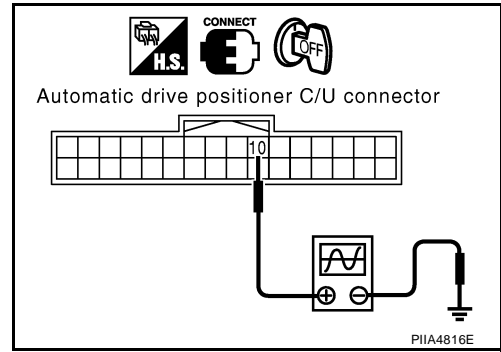

OK or NG

OK >> GO TO 3.

NG >> Check the following.

- When voltage wave form does not appear with a constant voltage (approx. 5V), replace automatic drive positioner control unit.
- When voltage wave form does not appear with a constant voltage (approx. 0V), replace driver seat control unit.

3. CHECK UART LINE HARNESS

1. Disconnect driver seat control unit and automatic drive positioner control unit.
2. Check continuity between driver seat control unit connector P2 terminals 1, 17, and automatic drive positioner connector M33 terminals 10, 26.

1 - 10 : Continuity should exist.

17 - 26 : Continuity should exist.

3. Check continuity between driver seat control unit connector P2 terminals 1, 17 and ground.

1 - Ground : Continuity should not exist.

17 - Ground : Continuity should not exist.

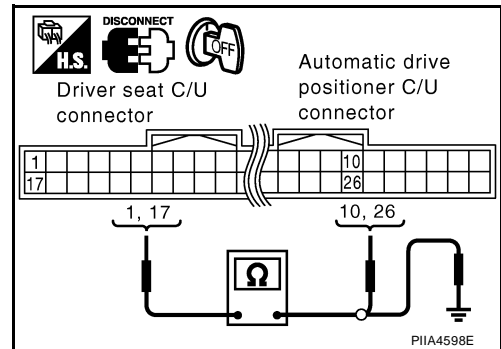

OK or NG

OK >> GO TO 4.

NG >> Repair or replace harness.

4. CHECK DRIVER SEAT CONTROL UNIT

Does the automatic drive positioner operate when the driver seat control unit is exchanged?

OK or NG

OK >> Replace driver seat control unit.

NG >> Replace automatic drive positioner control unit.

AUTOMATIC DRIVE POSITIONER

Removal and Installation

EIS004GJ

Refer to [ACC-3, "ACCELERATOR CONTROL SYSTEM"](#) and [BR-6, "BRAKE PEDAL"](#) .

A

B

C

D

E

F

G

H

SE

J

K

L

M

POWER SEAT

POWER SEAT

PFP:87016

Schematic

EIS004GK

(PP) : WITH FRONT PASSENGER POWER SEAT

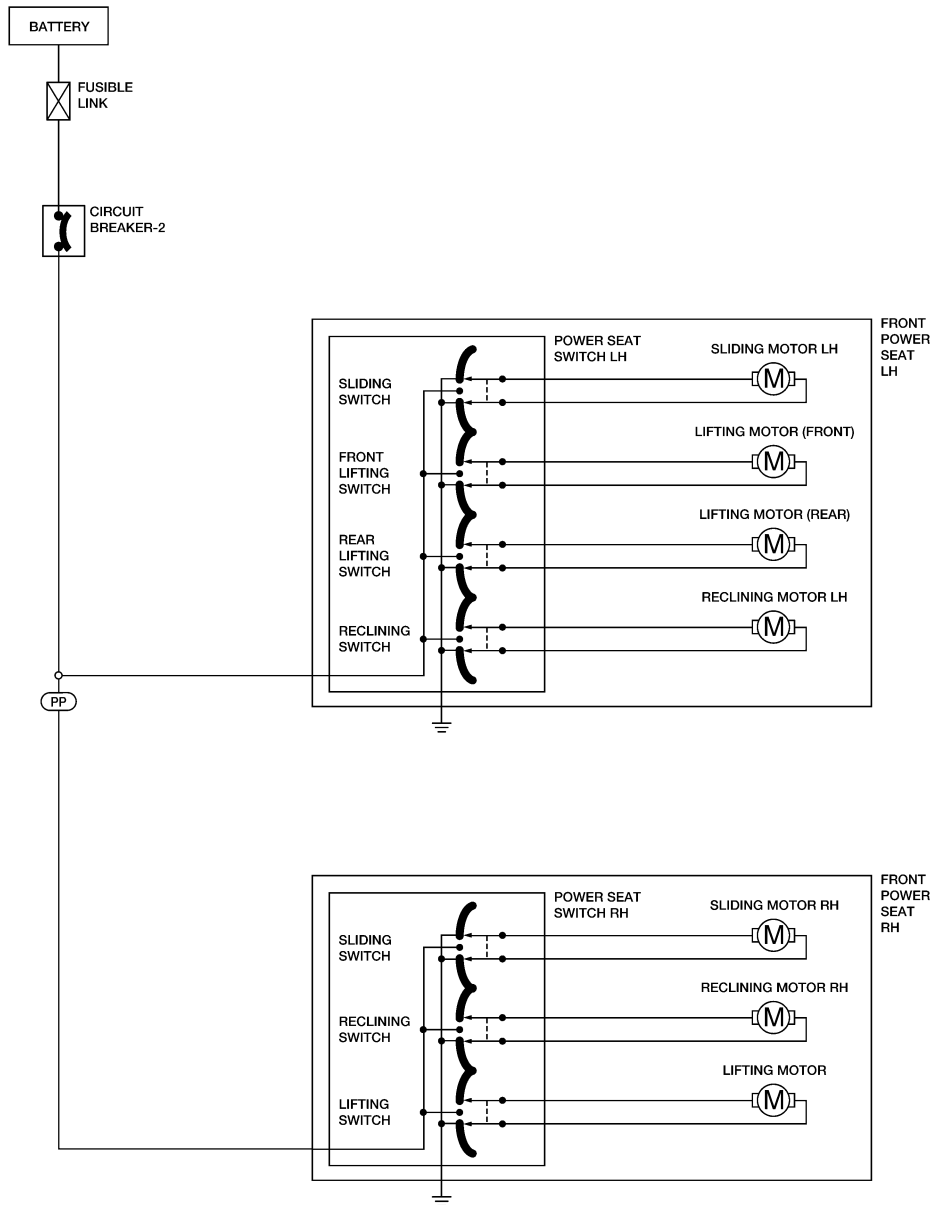

WIWA1407E

POWER SEAT

Wiring Diagram — SEAT —

EIS004GL

SE-SEAT-01

⬡PP⬡ : WITH FRONT PASSENGER POWER SEAT

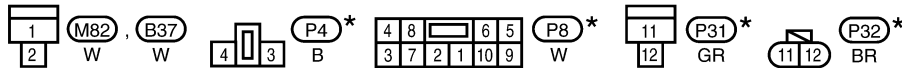
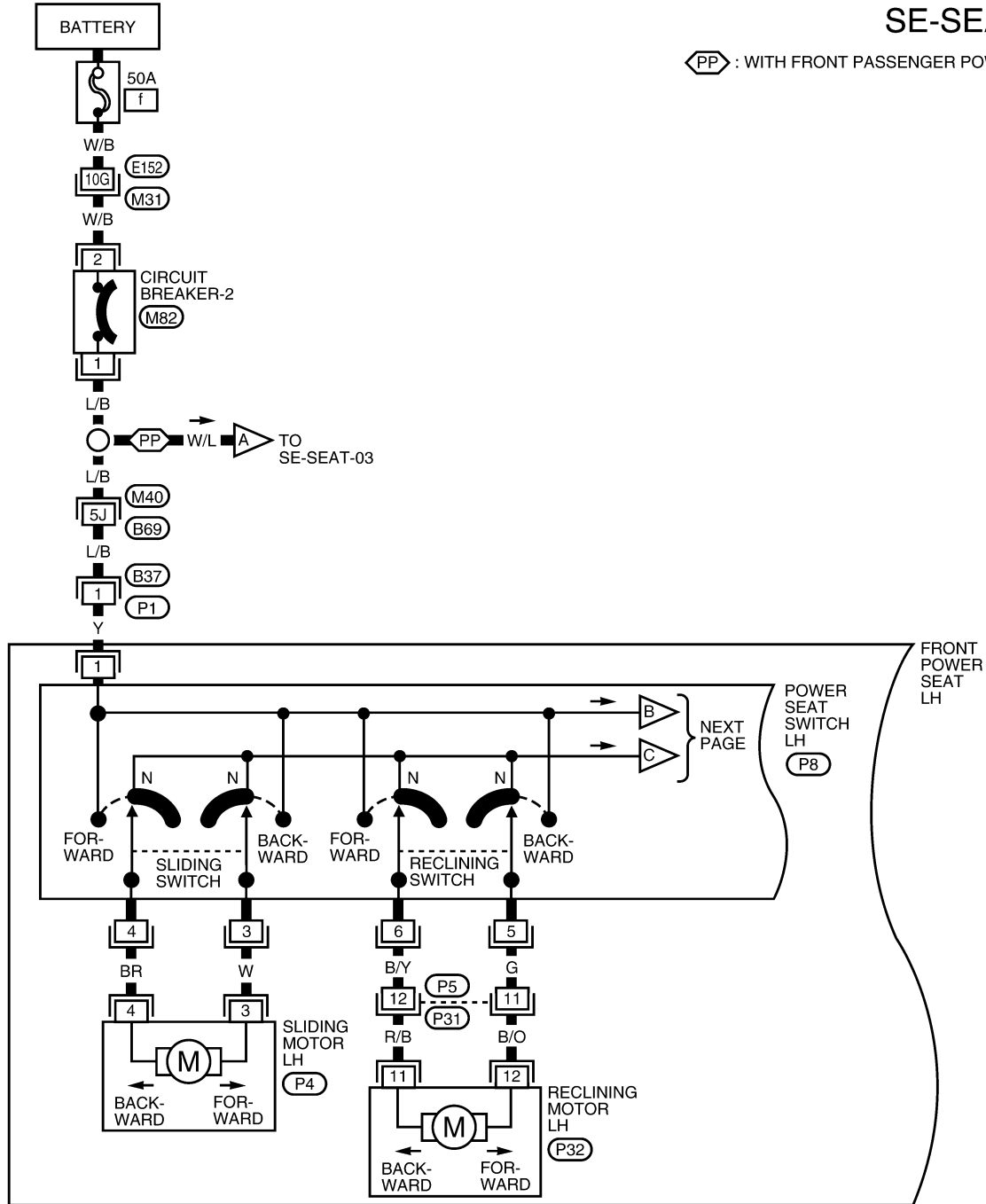

REFER TO THE FOLLOWING.
 ⬡M31⬡, ⬡M40⬡ - SUPER
 MULTIPLE JUNCTION (SMJ)

* : THIS CONNECTOR IS NOT SHOWN IN "HARNESS LAYOUT" OF PG SECTION.

WIWA1371E

POWER SEAT

SE-SEAT-02

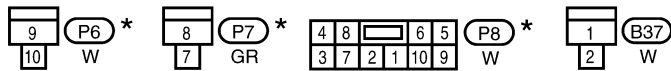
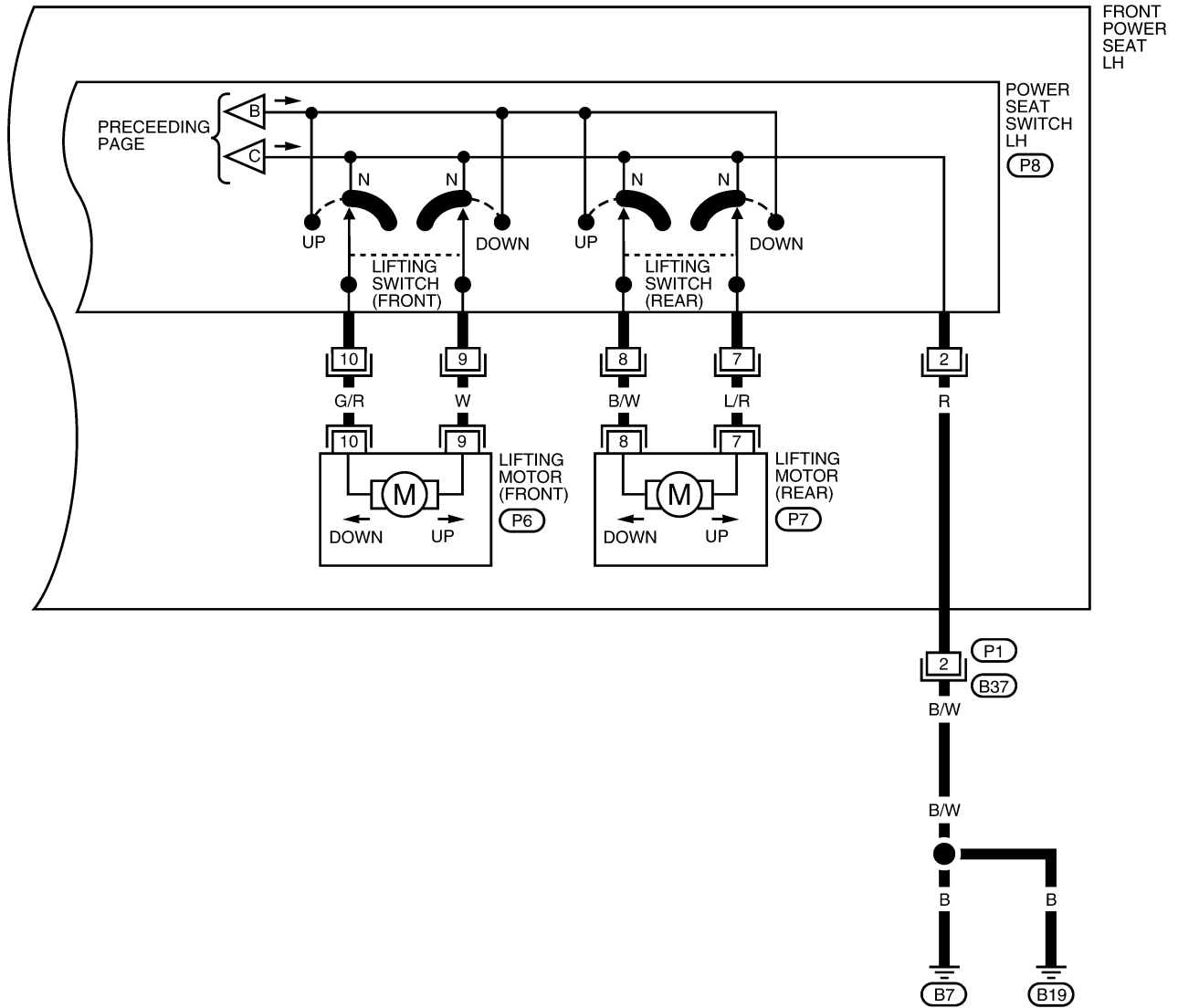

*: THIS CONNECTOR IS NOT SHOWN IN "HARNESS LAYOUT" OF PG SECTION.

WIWA1372E

POWER SEAT

SE-SEAT-03

A
B
C
D
E
F
G
H
SE
J
K
L
M

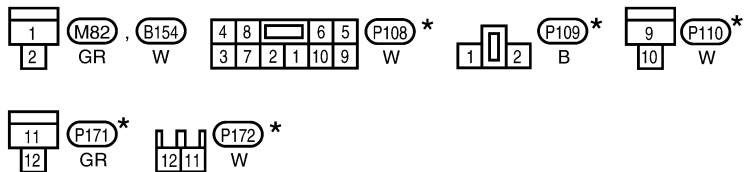
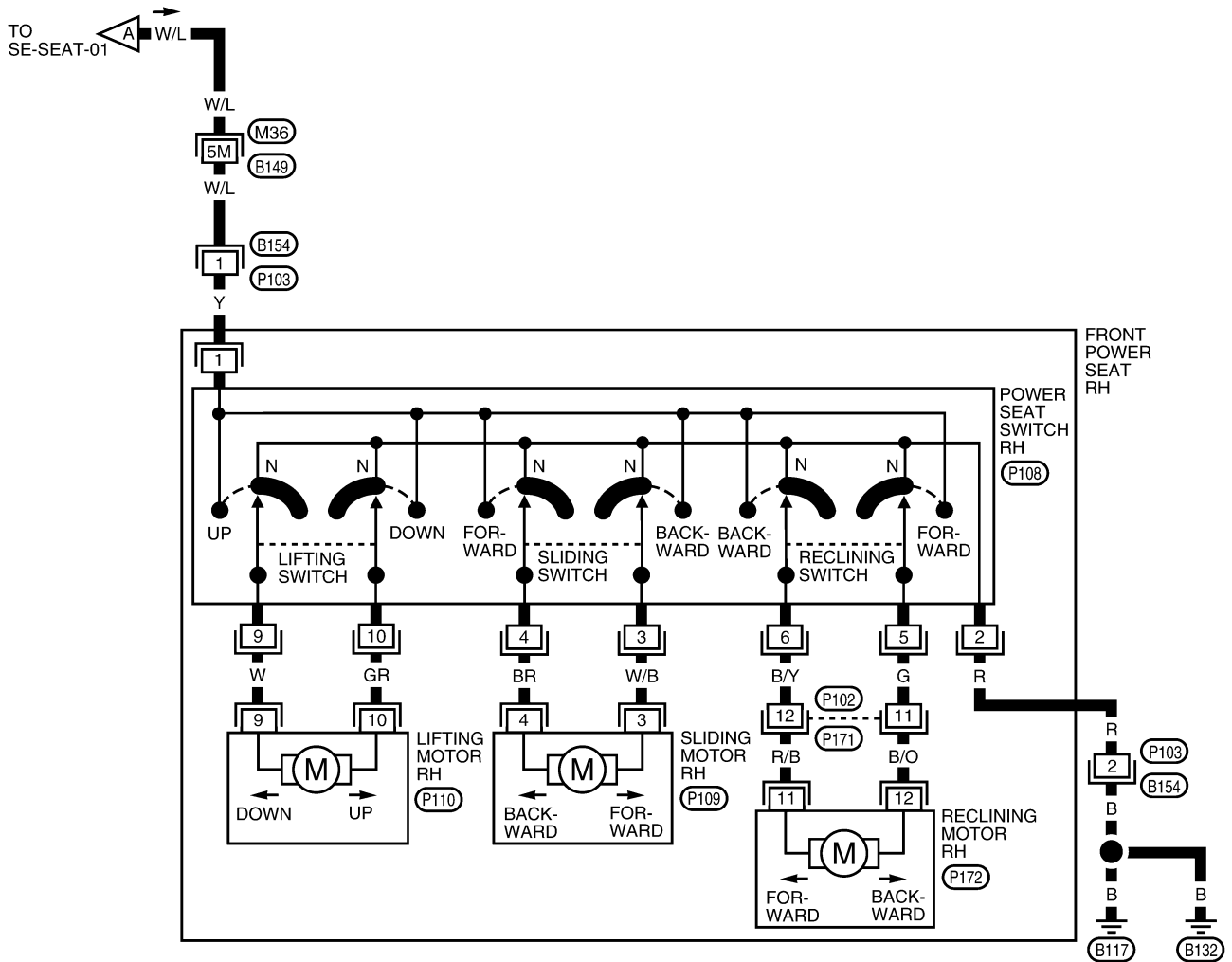

REFER TO THE FOLLOWING.
M31, **M36** - SUPER
 MULTIPLE JUNCTION (SMJ)

* : THIS CONNECTOR IS NOT SHOWN IN "HARNESS LAYOUT" OF PG SECTION.

WIWA1373E

HEATED SEAT

HEATED SEAT

PFP:87335

Description

EIS004GM

- When handling seat, be extremely careful not to scratch heating unit.
- Front passenger seat cushion and seatbacks equipped with air bags cannot be disassembled. They are replaced as assemblies only.
- Do not use any organic solvent, such as thinner, benzene, alcohol, etc. to clean trim.

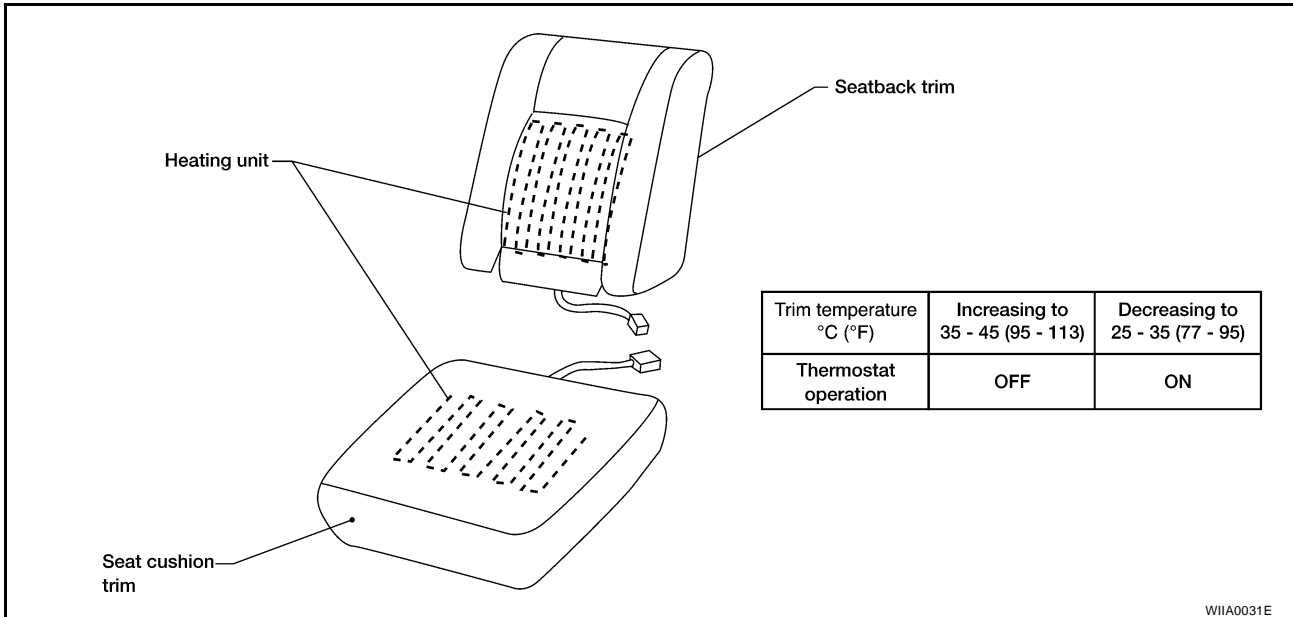

W1IA0031E

HEATED SEAT

Wiring Diagram — HSEAT —

EIS004GO

SE-HSEAT-01

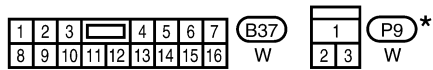
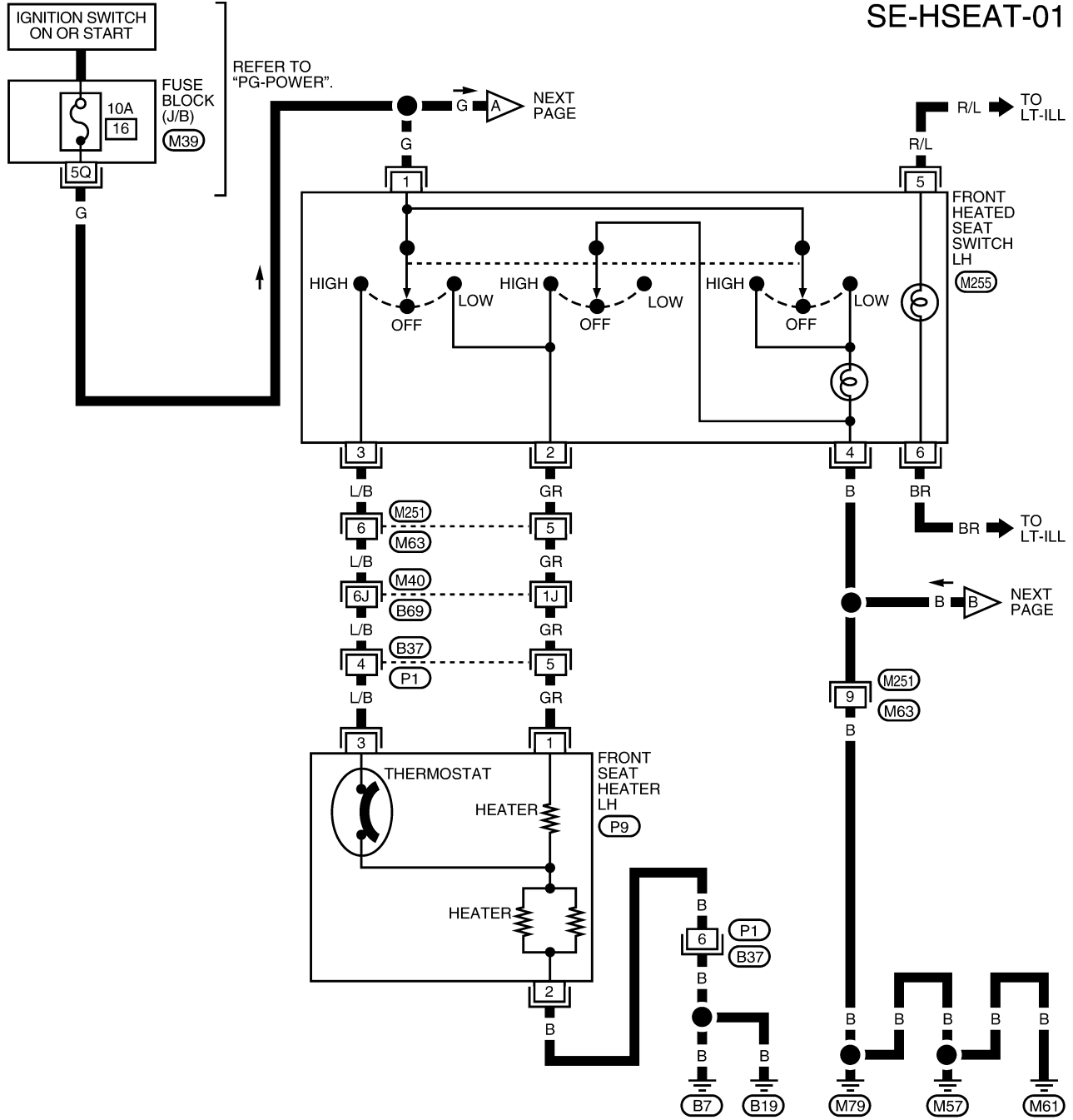

REFER TO THE FOLLOWING.
 (M40) - SUPER MULTIPLE JUNCTION (SMJ)

* : THIS CONNECTOR IS NOT SHOWN IN "HARNESS LAYOUT" OF PG SECTION.

WIWA0600E

HEATED SEAT

SE-HSEAT-02

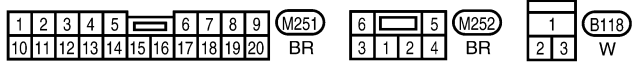
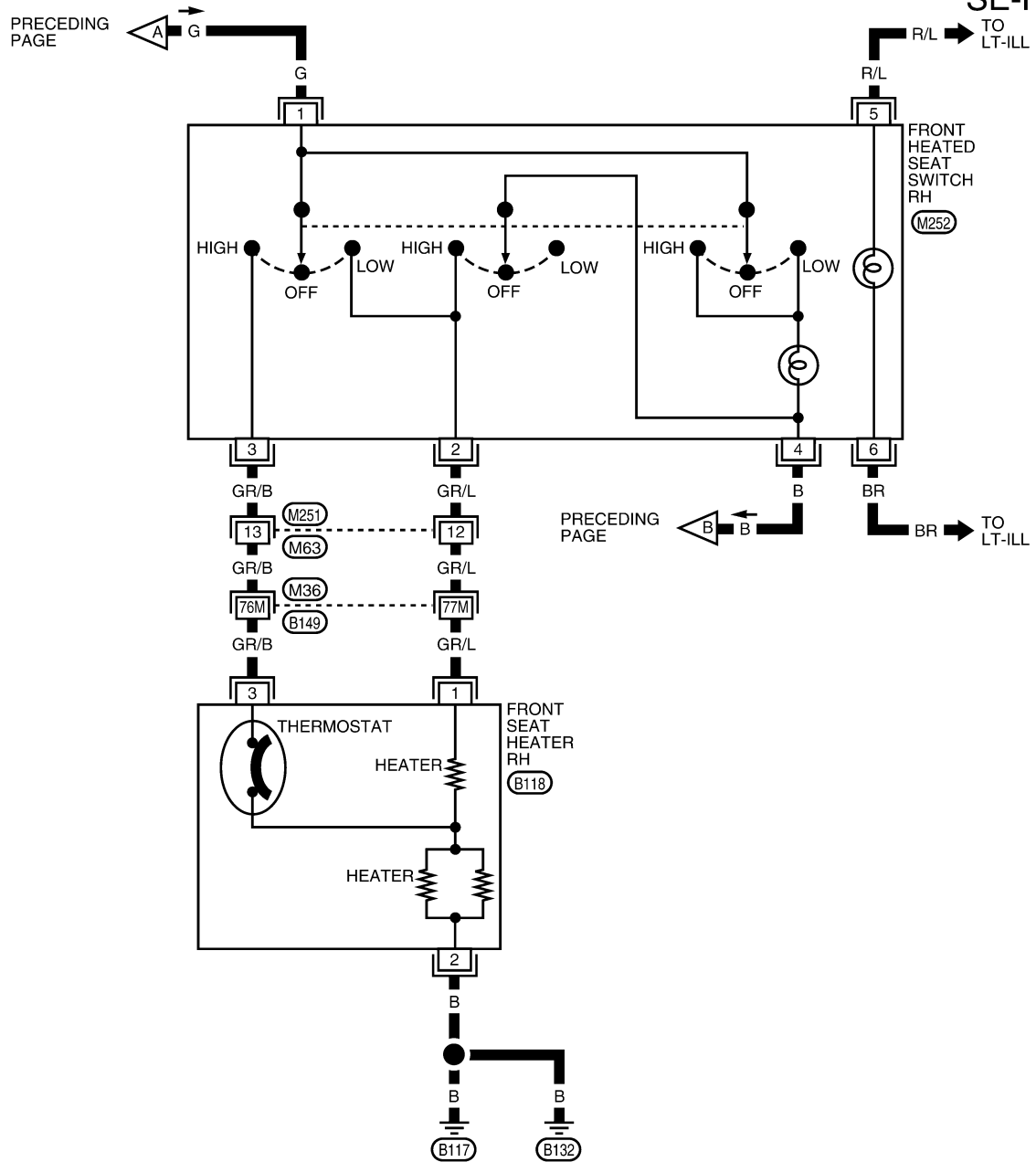

REFER TO THE FOLLOWING.
 (M36) - SUPER MULTIPLE
 JUNCTION (SMJ)

WIWA0601E

FRONT SEAT

PFP:87000

FRONT SEAT

Removal and Installation

EIS004GP

Driver Seat

SEC. 870

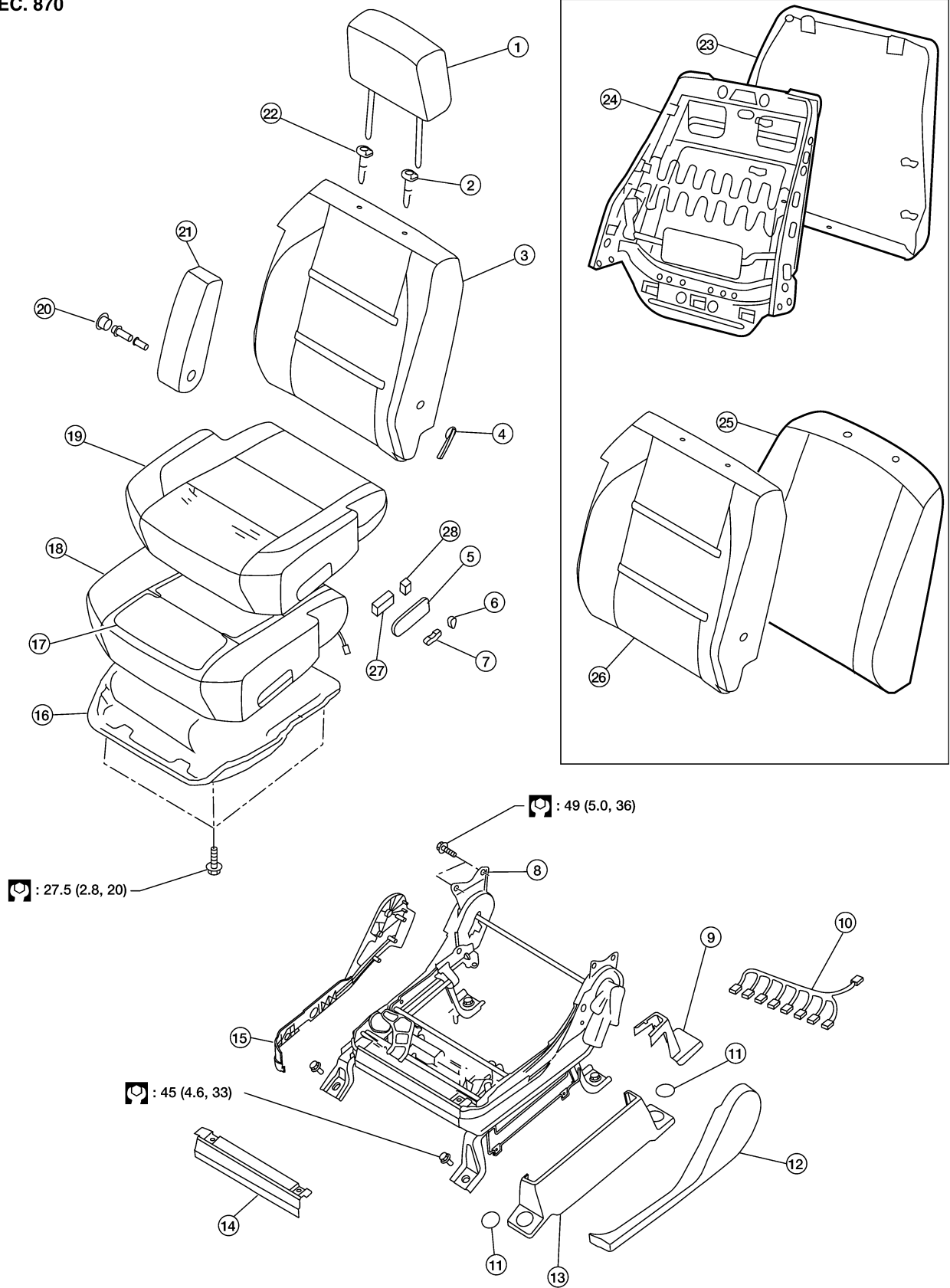

A
B
C
D
E
F
G
H
SE
J
K
L
M

FRONT SEAT

- | | | |
|---------------------------------------|--|---|
| 1. Headrest | 2. Headrest holder with multi position lock | 3. Seatback assembly |
| 4. Lumbar support lever | 5. Power seat switch escutcheon | 6. Recliner switch knob |
| 7. Slide switch knob | 8. Driver power seat frame assembly | 9. LH outer leg cover |
| 10. Driver seat wiring harness | 11. Bolt cover | 12. Seat cushion outer finisher |
| 13. Outer pedestal finisher | 14. Seat cushion front finisher | 15. Seat cushion inner finisher |
| 16. Seat cushion frame | 17. Seat cushion heating element | 18. Seat cushion pad |
| 19. Seat cushion trim cover | 20. Armrest bolt cover | 21. Armrest assembly |
| 22. Headrest holder | 23. Seatback board | 24. Seatback frame without side air bag |
| 25. Seatback pad without side air bag | 26. Seatback trim cover without side air bag | 27. Seat slide switch |
| 28. Recliner switch | | |

FRONT SEAT

Center Seat

SEC. 870

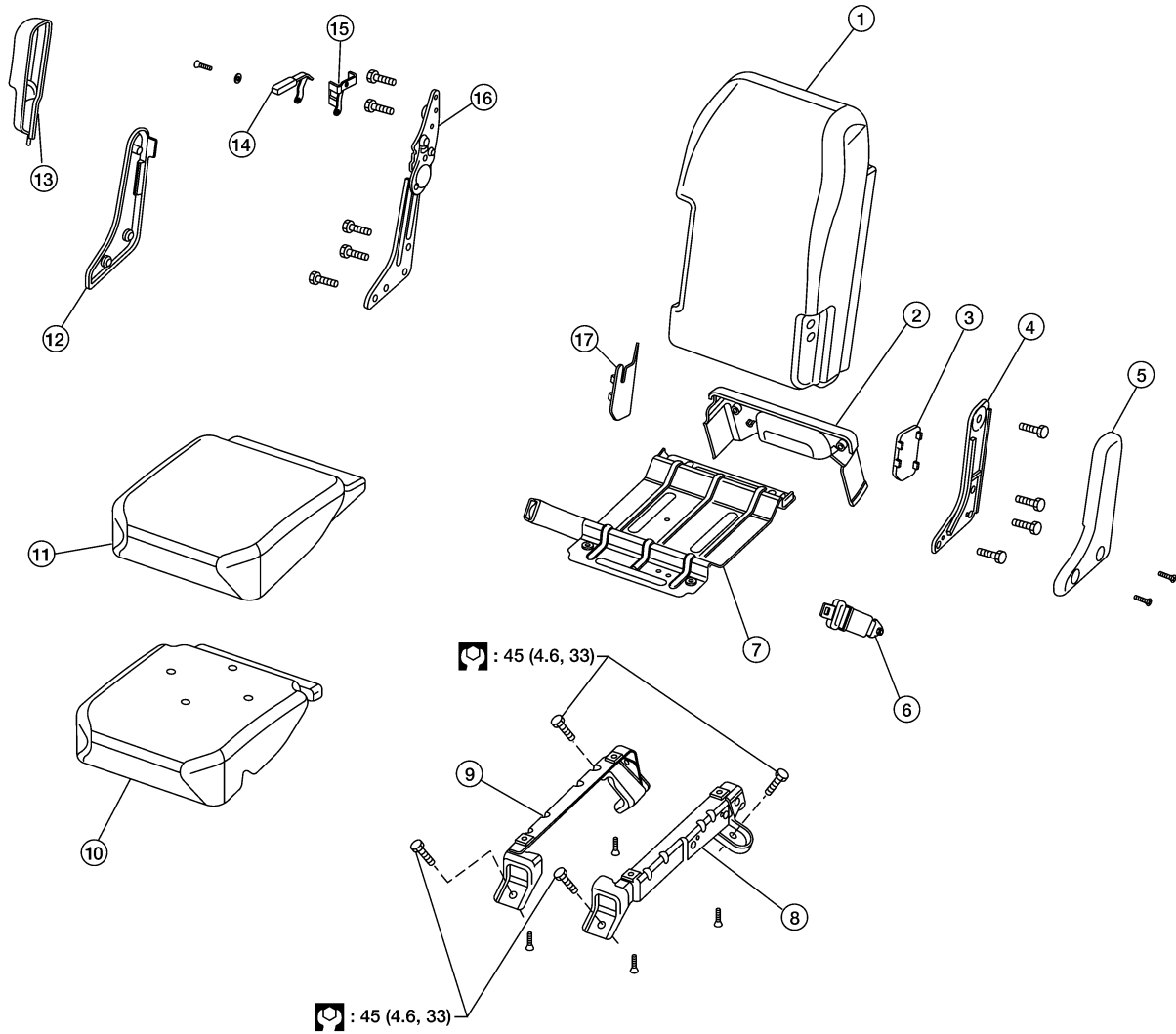

A
B
C
D
E
F
G
H
SE
J
K
L
M

- 1. Armrest assembly
- 4. Armrest support

- 2. Rear hinge cover
- 5. Armrest bolt cover

- 3. Inboard armrest support cover
- 6. Seat belt tongue

W11A0947E

FRONT SEAT

- | | | |
|-------------------------------|---------------------------------|-------------------------------|
| 7. Center seat pan | 8. LH pedestal support | 9. RH pedestal support |
| 10. Seat cushion pad | 11. Seat cushion cover | 12. Lower armrest pivot cover |
| 13. Upper armrest pivot cover | 14. Armrest pivot release lever | 15. Armrest release bracket |
| 16. Armrest pivot arm | 17. Inboard lower pivot cover | |

FRONT SEAT

Passenger Seat

SEC. 870

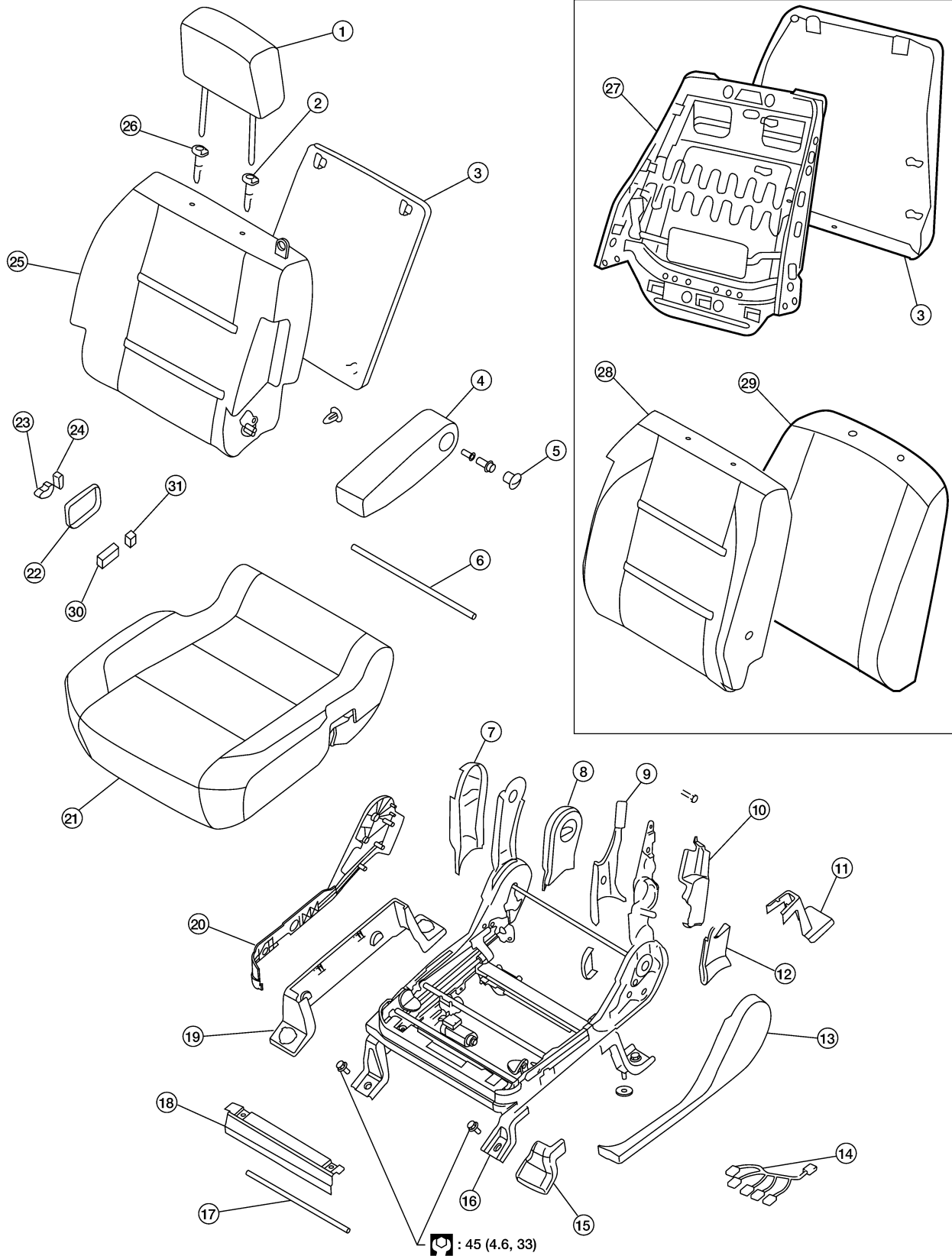

A
B
C
D
E
F
G
H
SE
J
K
L
M

1. Headrest

2. Headrest holder with multi position lock

3. Seatback board lock

4. Armrest assembly

5. Armrest bolt cover

6. Fold flat link bar

W1IA0948E

FRONT SEAT

- | | | |
|--|---------------------------------------|---|
| 7. Outboard reclining arm outer cover | 8. Outboard reclining arm inner cover | 9. Inboard reclining arm inner cover |
| 10. Latch cover | 11. LH outer leg cover | 12. Outboard reclining arm inner cover |
| 13. Seat cushion inner cover | 14. Passenger seat wiring harness | 15. Inner front leg cover |
| 16. Power seat frame assembly | 17. NVH assembly | 18. Seat cushion front finisher |
| 19. Outer pedestal finisher | 20. Seat cushion outer finisher | 21. Seat cushion assembly |
| 22. Power seat switch escutcheon | 23. Slide switch knob | 24. Recliner switch knob |
| 25. Seatback assembly | 26. Headrest holder | 27. Seatback frame without side air bag |
| 28. Seatback trim cover without side air bag | 29. Seatback pad without side air bag | 30. Recliner switch |
| 31. Seat slide switch | | |

REMOVAL

CAUTION:

- When removing or installing the seat trim, handle it carefully to keep dirt out and avoid damage.
- Before removing the front seat, turn the ignition switch off, disconnect both battery cables and wait at least 3 minutes.
- When checking the power seat circuit for continuity using a circuit tester, do not confuse its connector with the side air bag module connector. Such an error may cause the air bag to deploy.
- Do not drop, tilt, or bump the side air bag module while installing the seat. Always handle it with care.
- After front side air bag module inflates, front seatback assembly must be replaced.
- Front passenger seat is equipped with Occupant Classification System sensor and control module. Do not disassemble front passenger seat cushion assembly or remove trim as this will affect the Occupant Classification System calibration.
- Always replace passenger seat cushion as an assembly.

1. Slide the seat until the four seat to body bolts are visible and a tool can be inserted.

NOTE:

- If disassembling the seat after removal, set the front/rear cushion lifters to the top position.

2. Disconnect both battery cables and wait at least 3 minutes.
3. Disconnect the side air bag module harness connector.
4. Remove the four seat to body bolts.
5. Disconnect the power seat harness connectors and remove the seat from the vehicle.

NOTE:

When removing and installing the seat, use shop cloths to protect the vehicle from damage.

INSTALLATION

Installation is in the reverse order of removal.

Disassembly and Assembly SEATBACK TRIM AND PAD

EIS004GQ

NOTE:

Only complete outboard seatback assemblies can be replaced on vehicles equipped with side air bags. Be sure to set the front/rear cushion lifter to the top position.

1. Remove the seatback board from the back of the seatback.

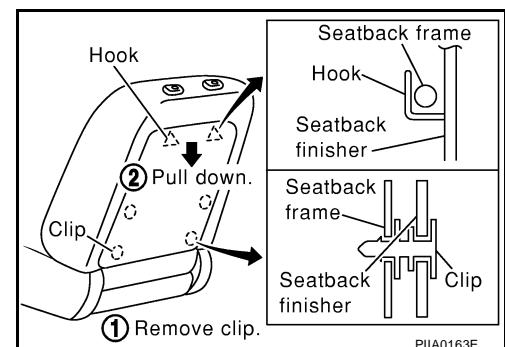

FRONT SEAT

- Remove the retainer.

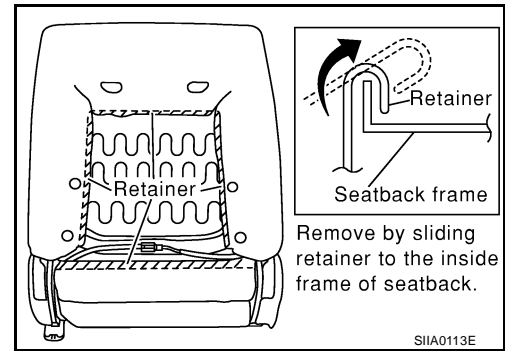

- Remove the headrest.

- From inside of the seatback, squeeze the headrest holder tabs at the base of the stay pipe and pull the up to remove.

NOTE:

Before installing the headrest holder, check its orientation (front/rear and right/left).

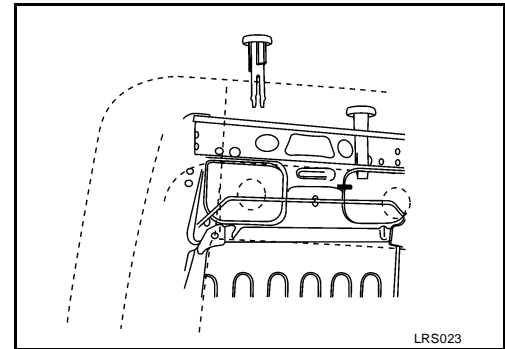

- Remove the snap ring and the lumbar support lever knob.

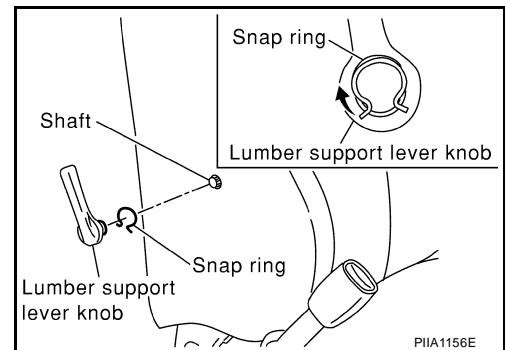

6. CAUTION:

On the passenger seat during installation, the wire harness clips must be installed in the holes they were originally in.

Do not add additional clips.

Disconnect the seatback heater harness. Remove the seatback trim and pad assembly. Remove the hog ring to separate the seatback trim from the pad and the heater unit.

REMOVAL OF SEATBACK ASSEMBLY

- Remove the seatback board from the back of the seatback.

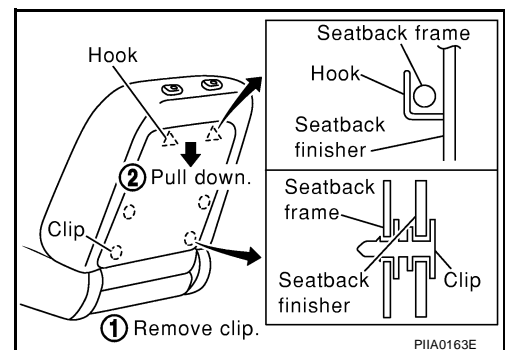

FRONT SEAT

2. Remove the retainer.
3. Remove the side air bag harness connector from the seat cushion.
4. Remove the seatback bolts (2 for each side) and seatback assembly.

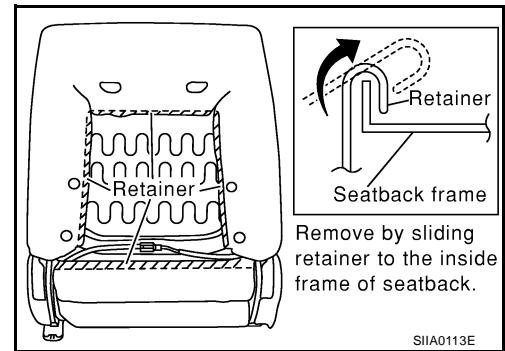

INSTALLATION OF SEATBACK ASSEMBLY

- Installation is in the reverse order of removal.

SEAT CUSHION TRIM AND PAD

CAUTION:

- Front passenger seat is equipped with Occupant Classification System sensor and control module. Do not disassemble front passenger seat cushion assembly or remove trim as this will affect the Occupant Classification System calibration.
- Always replace passenger seat cushion as an assembly.
- When removed, the passenger seat cushion must always be placed pan side UP to prevent damage.
- During installation, the wire harness clips must be installed in the holes they were originally in. Do not add additional clips.
- The Occupant Classification System control module can only be replaced as part of the seat cushion assembly.

NOTE:

If the vehicle has been involved in a collision the seat must be inspected for damage. Refer to [SRS-51, "COLLISION DIAGNOSIS"](#).

1. Remove the power seat switch knobs and power seat switch escutcheon (or recline knobs on manual seat).

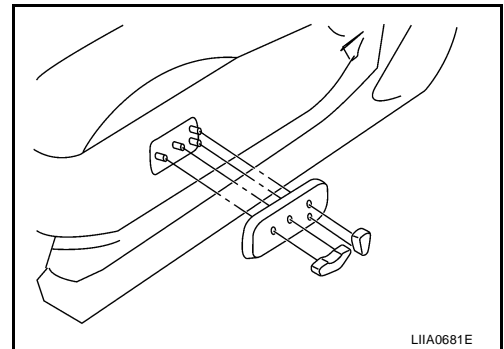

2. Remove the front seat cushion finisher (inner).

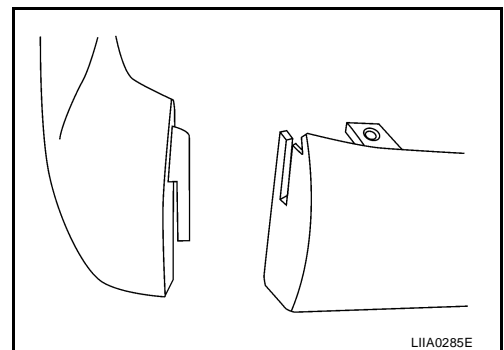

3. Remove the power seat switch screws (or lift knobs on manual seats).

FRONT SEAT

4. Remove four bolts and the seat cushion assembly.

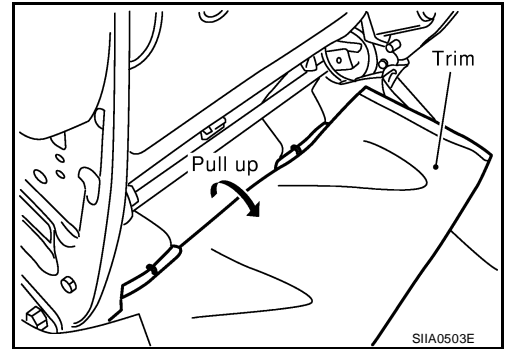

5. Remove the retainer on the seat cushion frame, then remove the harness connector for the seat heater.
6. On the drivers seat only, after removing the seat cushion trim and pad, remove the hog rings to separate the trim cover from the pad and seat cushion heater unit.

A

B

C

D

E

F

G

H

SE

J

K

L

M

REAR SEAT

REAR SEAT

PFP:88300

Removal and Installation

EIS004GR

REMOVAL

1. Lift the seat cushion into the stowed position.
2. Remove the seatbelt and seat anchor bolts.

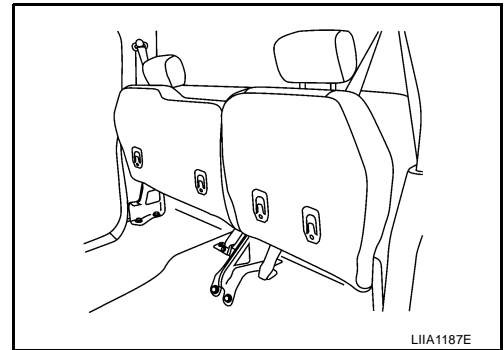

3. Release the seatback and remove the seat.

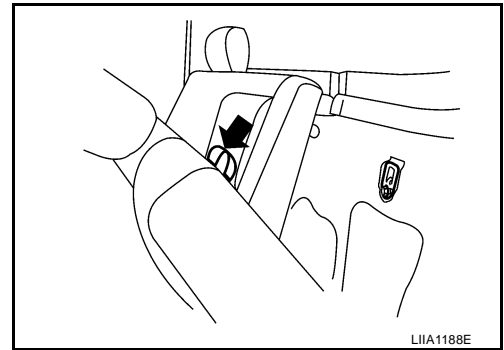

INSTALLATION

Installation is in the reverse order of removal.

REAR SEAT

Disassembly and Assembly

EIS004GS

LH

SEC. 881

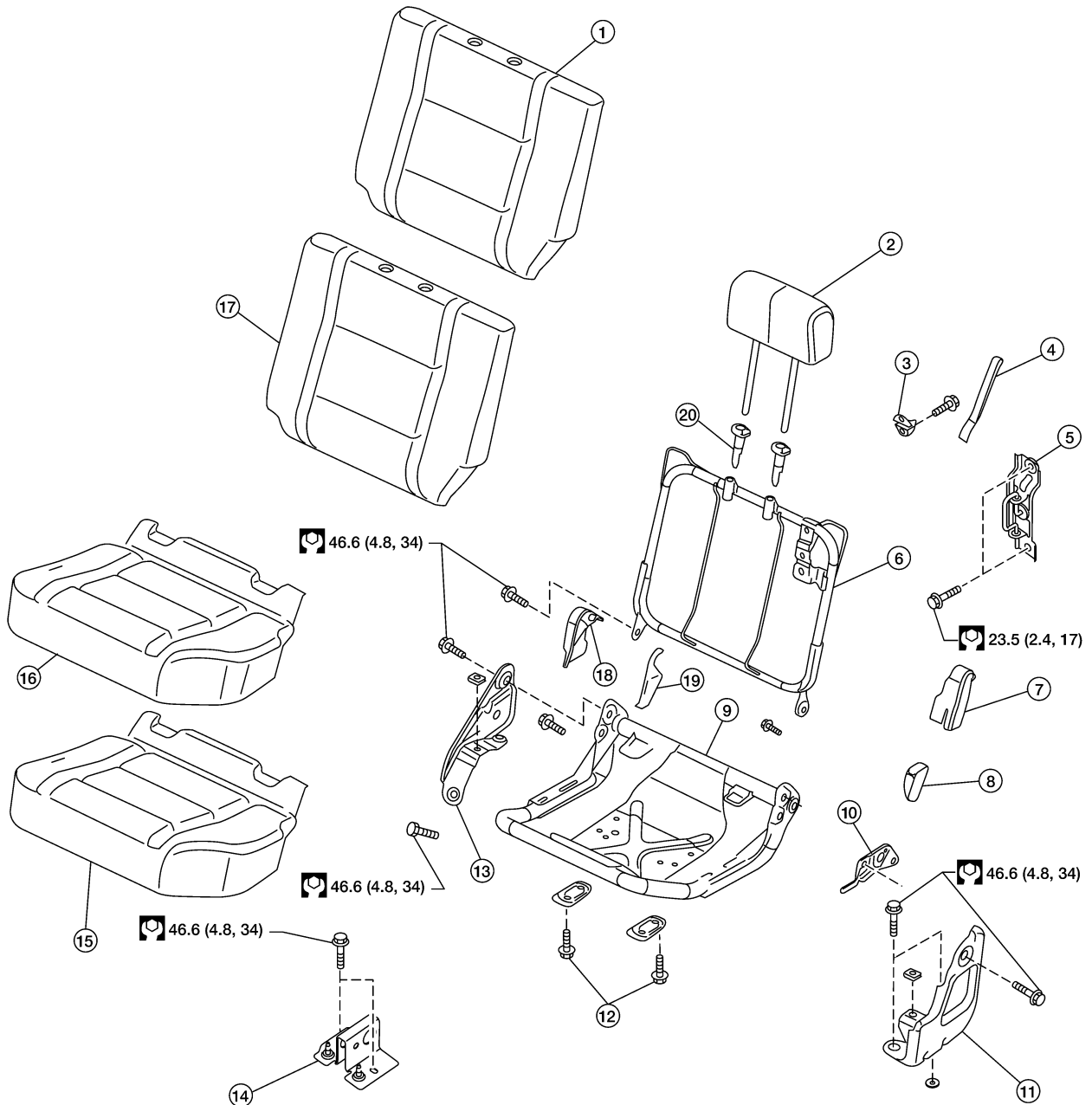

A
B
C
D
E
F
G
H
SE
J
K
L
M

WHIA0949E

REAR SEAT

- | | | |
|-----------------------------------|---------------------------|-------------------------------|
| 1. Seatback pad | 2. Headrest | 3. Seatback latch |
| 4. Seatback latch release strap | 5. Seatback latch striker | 6. Seatback frame |
| 7. Outboard pivot cover | 8. Release lever handle | 9. Seat cushion frame |
| 10. Seat cushion release assembly | 11. Outboard seat support | 12. Grocery bag hooks |
| 13. Inboard seat support | 14. Rear seat bracket | 15. Seat cushion pad |
| 16. Seat cushion trim | 17. Seatback trim | 18. Inboard outer pivot cover |
| 19. Inner inboard pivot cover | 20. Headrest guide | |

REAR SEAT

RH

SEC. 881

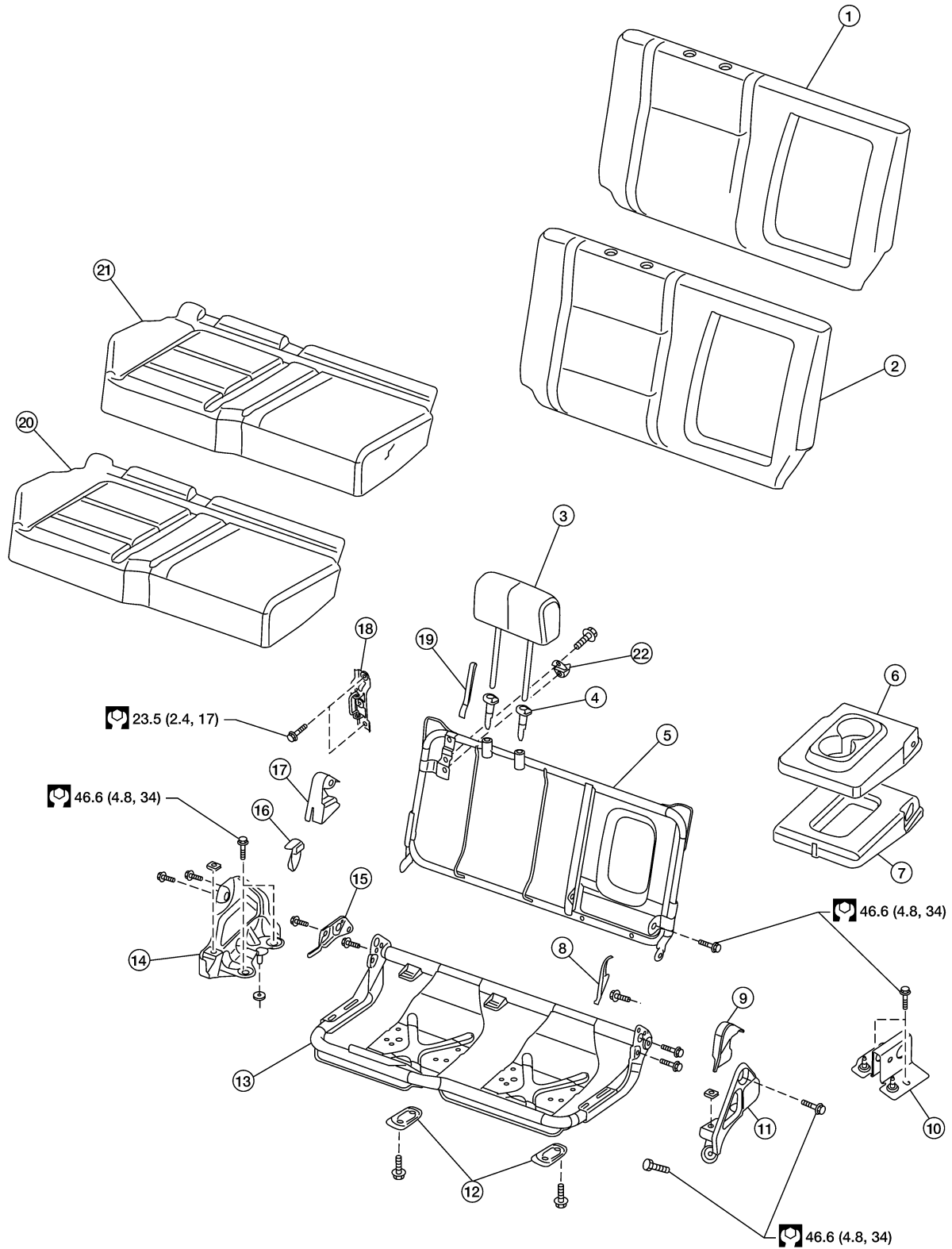

A
B
C
D
E
F
G
H
SE
J
K
L
M

- 1. Seatback trim
- 4. Locking headrest guide

- 2. Seatback pad
- 5. Seatback frame

- 3. Headrest
- 6. Arm rest trim

W11A0950E

REAR SEAT

- | | | |
|---------------------------------|------------------------------------|--------------------------------|
| 7. Arm rest pad and frame | 8. Inner inboard hinge cover | 9. Outer inboard hinge cover |
| 10. Rear seat bracket | 11. Inboard seatback pivot anchor | 12. Grocery bag hooks |
| 13. Seat cushion frame | 14. Outboard seatback pivot anchor | 15. Seat cushion release lever |
| 16. Seat cushion release handle | 17. Outboard pivot cover | 18. Seatback striker assembly |
| 19. Seatback release strap | 20. Seat cushion pad | 21. Seat cushion trim |
| 22. Seatback latch assembly | | |