

**SECTION MA**  
**MAINTENANCE**

A  
 B  
 C  
 D  
 E  
 F  
 G  
 H  
 I  
 J  
 K  
 L  
 M  
 N  
 O

**CONTENTS**

<p><b>PRECAUTION</b> ..... 2</p> <p><b>PRECAUTIONS</b> ..... 2</p> <p style="padding-left: 20px;">Precaution for Supplemental Restraint System (SRS) "AIR BAG" and "SEAT BELT PRE-TENSIONER" .....2</p> <p><b>PREPARATION</b> ..... 3</p> <p><b>PREPARATION</b> ..... 3</p> <p style="padding-left: 20px;">Special Service Tool .....3</p> <p style="padding-left: 20px;">Commercial Service Tool .....3</p> <p><b>ON-VEHICLE MAINTENANCE</b> ..... 4</p> <p><b>GENERAL MAINTENANCE</b> ..... 4</p> <p style="padding-left: 20px;">General Maintenance .....4</p> <p><b>PERIODIC MAINTENANCE</b> ..... 6</p> <p style="padding-left: 20px;">Introduction of Periodic Maintenance .....6</p> <p style="padding-left: 20px;">Schedule 1 .....6</p> <p style="padding-left: 20px;">Schedule 2 .....8</p> <p><b>RECOMMENDED FLUIDS AND LUBRICANTS</b> .....10</p> <p style="padding-left: 20px;">Fluids and Lubricants ..... 10</p> <p style="padding-left: 20px;">Engine Oil Recommendation ..... 11</p> <p><b>ENGINE MAINTENANCE</b> .....12</p> <p style="padding-left: 20px;">Checking Drive Belts ..... 12</p> <p style="padding-left: 20px;">Changing Engine Coolant ..... 12</p> <p style="padding-left: 20px;">Checking Fuel Line ..... 15</p>	<p style="padding-left: 20px;">Changing Fuel Filter .....15</p> <p style="padding-left: 20px;">Changing Engine Air Cleaner Filter .....15</p> <p style="padding-left: 20px;">Changing Engine Oil .....16</p> <p style="padding-left: 20px;">Changing Oil Filter .....16</p> <p style="padding-left: 20px;">Changing Spark Plugs .....18</p> <p style="padding-left: 20px;">Checking EVAP Vapor Line .....19</p> <p><b>CHASSIS AND BODY MAINTENANCE</b> .....20</p> <p style="padding-left: 20px;">Changing In-cabin Microfilter .....20</p> <p style="padding-left: 20px;">Checking Exhaust System .....21</p> <p style="padding-left: 20px;">Checking the A/T Fluid (ATF) .....21</p> <p style="padding-left: 20px;">Changing the A/T Fluid (ATF) .....23</p> <p style="padding-left: 20px;">Changing Transfer Fluid .....24</p> <p style="padding-left: 20px;">Checking Transfer Fluid .....24</p> <p style="padding-left: 20px;">Checking Propeller Shaft .....25</p> <p style="padding-left: 20px;">Changing Front Final Drive Oil .....25</p> <p style="padding-left: 20px;">Checking Front Final Drive Oil .....25</p> <p style="padding-left: 20px;">Changing Rear Final Drive Oil .....26</p> <p style="padding-left: 20px;">Checking Rear Final Drive Oil .....26</p> <p style="padding-left: 20px;">Wheel and Tire Assembly .....26</p> <p style="padding-left: 20px;">Checking Brake Fluid Level and Leaks .....28</p> <p style="padding-left: 20px;">Checking Brake Line and Cables .....28</p> <p style="padding-left: 20px;">Checking Disc Brake .....28</p> <p style="padding-left: 20px;">Checking Steering Gear and Linkage .....29</p> <p style="padding-left: 20px;">Checking Power Steering Fluid and Line .....29</p> <p style="padding-left: 20px;">Checking Axle and Suspension Parts .....30</p> <p style="padding-left: 20px;">Lubricating Locks, Hinges and Hood Latches .....31</p> <p style="padding-left: 20px;">Checking Seat Belts, Buckles, Retractors, Anchors and Adjusters .....31</p>
--	---

# PRECAUTIONS

< PRECAUTION >

## PRECAUTION

### PRECAUTIONS

#### Precaution for Supplemental Restraint System (SRS) "AIR BAG" and "SEAT BELT PRE-TENSIONER"

INFOID:000000005712951

The Supplemental Restraint System such as "AIR BAG" and "SEAT BELT PRE-TENSIONER", used along with a front seat belt, helps to reduce the risk or severity of injury to the driver and front passenger for certain types of collision. This system includes seat belt switch inputs and dual stage front air bag modules. The SRS system uses the seat belt switches to determine the front air bag deployment, and may only deploy one front air bag, depending on the severity of a collision and whether the front occupants are belted or unbelted. Information necessary to service the system safely is included in the SR and SB section of this Service Manual.

**WARNING:**

- To avoid rendering the SRS inoperative, which could increase the risk of personal injury or death in the event of a collision which would result in air bag inflation, all maintenance must be performed by an authorized NISSAN/INFINITI dealer.
- Improper maintenance, including incorrect removal and installation of the SRS, can lead to personal injury caused by unintentional activation of the system. For removal of Spiral Cable and Air Bag Module, see the SR section.
- Do not use electrical test equipment on any circuit related to the SRS unless instructed to in this Service Manual. SRS wiring harnesses can be identified by yellow and/or orange harnesses or harness connectors.

#### PRECAUTIONS WHEN USING POWER TOOLS (AIR OR ELECTRIC) AND HAMMERS

**WARNING:**

- When working near the Airbag Diagnosis Sensor Unit or other Airbag System sensors with the Ignition ON or engine running, DO NOT use air or electric power tools or strike near the sensor(s) with a hammer. Heavy vibration could activate the sensor(s) and deploy the air bag(s), possibly causing serious injury.
- When using air or electric power tools or hammers, always switch the Ignition OFF, disconnect the battery, and wait at least 3 minutes before performing any service.

# PREPARATION

< PREPARATION >

## PREPARATION

### PREPARATION

#### Special Service Tool

INFOID:000000005387343

The actual shapes of the Kent-Moore tools may differ from those of the special service tools illustrated here.

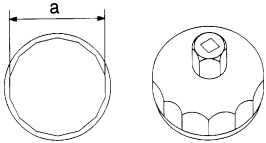
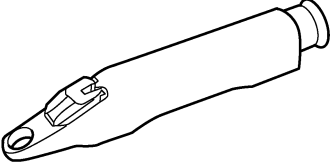
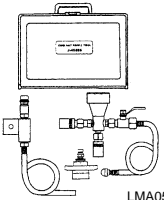
Tool number (Kent-Moore No.) Tool name	Description
KV10115801 (J-38956) Oil filter cap wrench <div style="text-align: center;">  <p>NT375</p> </div>	Removing and installing oil filter <b>a: 64.3 mm (2.531 in)</b>
KV991J0010 (J-23688) Engine coolant refractometer <div style="text-align: center;">  <p>WBIA0539E</p> </div>	Checking concentration of ethylene glycol in engine coolant
KV991J0070 (J-45695) Coolant refill tool <div style="text-align: center;">  <p>LMA053</p> </div>	Filling cooling system

#### Commercial Service Tool

INFOID:000000005387344

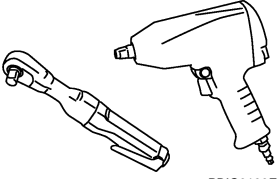
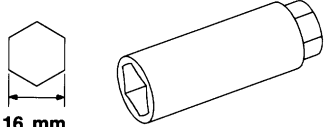
(Kent-Moore No.) Tool name	Description
Power tool <div style="text-align: center;">  <p>PBIC0190E</p> </div>	Loosening bolts and nuts
Spark plug wrench <div style="text-align: center;">  <p>16 mm (0.63 in)</p> <p>S-NT047</p> </div>	Removing and installing spark plug

A  
B  
C  
D  
E  
F  
G  
H  
I  
J  
K  
L  
M  
N  
O

MA

# GENERAL MAINTENANCE

< ON-VEHICLE MAINTENANCE >

## ON-VEHICLE MAINTENANCE

### GENERAL MAINTENANCE

#### General Maintenance

INFOID:000000005387345

General maintenance includes those items which should be checked during the normal day-to-day operation of the vehicle. They are essential if the vehicle is to continue operating properly. The owner can perform these checks and inspections or have their NISSAN dealers perform them.

#### OUTSIDE THE VEHICLE

The maintenance items listed here should be performed from time to time, unless otherwise specified.

Item		Reference page
<b>Tires</b>	Check the pressure with a gauge often and always prior to long distance trips. Adjust the pressure in all tires, including the spare, to the pressure specified. Check carefully for damage, cuts or excessive wear.	<a href="#">WT-50</a>
<b>Wheel lug nuts</b>	When checking the tires, make sure no nuts are missing, and check for any loose nuts. Tighten if necessary.	<a href="#">WT-46</a>
<b>Windshield</b>	Clean the windshield on a regular basis. Check the windshield at least every six months for cracks or other damage. Repair as necessary.	<a href="#">GW-10</a>
<b>Tire rotation</b>	Tires should be rotated every 12,000 km (7,500 miles).	<a href="#">WT-46</a>
<b>Tire Pressure Monitoring System (TPMS) transmitter components</b>	Replace the TPMS transmitter grommet seat, valve core and cap when the tires are replaced due to wear or age.	<a href="#">WT-48</a>
<b>Wheel alignment and balance</b>	If the vehicle pulls to either side while driving on a straight and level road, or if you detect uneven or abnormal tire wear, there may be a need for wheel alignment. If the steering wheel or seat vibrates at normal highway speeds, wheel balancing may be needed.	<a href="#">FSU-5, WT-46</a>
<b>Windshield wiper blades</b>	Check for cracks or wear if they do not wipe properly.	<a href="#">WW-61</a>
<b>Doors and engine hood</b>	Check that all doors and the engine hood operate smoothly as well as the back tail gate. Also make sure that all latches lock securely. Lubricate if necessary. Make sure that the secondary latch keeps the engine hood from opening when the primary latch is released. When driving in areas using road salt or other corrosive materials, check lubrication frequently.	<a href="#">MA-31</a>
<b>Lamps</b>	Make sure that the head lamps, stop lamps, tail lamps, turn signal lamps, and other lamps are all operating properly and installed securely. Also check head lamp aim. Clean the head lamps on a regular basis.	<a href="#">EXL-139</a>

#### INSIDE THE VEHICLE

The maintenance items listed here should be checked on a regular basis, such as when performing periodic maintenance, cleaning the vehicle, etc.

Item		Reference page
<b>Warning lamps and chimes</b>	Make sure that all warning lamps and chimes are operating properly.	<a href="#">WCS-4</a>
<b>Windshield wiper and washer</b>	Check that the windshield wipers and washer operate properly and that the wipers do not streak.	<a href="#">WW-62</a>
<b>Windshield defroster</b>	Check that the air comes out of the defroster outlets properly and in sufficient quantity when operating the heater or air conditioner.	—
<b>Steering wheel</b>	Check that it has the specified play. Be sure to check for changes in the steering condition, such as excessive play, hard steering or strange noises. Free play: Less than 35mm (1.38 in).	<a href="#">ST-30</a>
<b>Seats</b>	Check seat position controls such as seat adjusters, seatback recliner, etc. to make sure they operate smoothly and that all latches lock securely in every position. Check that the head restraints move up and down smoothly and that the locks (if equipped) hold securely in all latched positions. Check that the latches lock securely for folding-down rear seat backs.	<a href="#">SE-19</a>

# GENERAL MAINTENANCE

## < ON-VEHICLE MAINTENANCE >

Item		Reference page	
<b>Seat belts</b>	Check that all parts of the seat belt system (e.g. buckles, anchors, adjusters and retractors) operate properly and smoothly and are installed securely. Check the belt webbing for cuts, fraying, wear or damage.	<a href="#">SB-10</a>	A
<b>Accelerator pedal</b>	Check the pedal for smooth operation. Keep the floor mats away from the pedal.	—	B
<b>Brakes</b>	Check that the brake does not pull the vehicle to one side when applied.	—	
<b>Brake pedal and booster</b>	Check the pedal for smooth operation and make sure it has the proper distance under it when depressed fully. Check the brake booster function. Keep the floor mats away from the pedal.	<a href="#">BR-13</a> , <a href="#">BR-8</a>	C
<b>Parking brake</b>	Check that the parking brake control has the proper travel and make sure that the vehicle is held securely on a fairly steep hill when only the parking brake is applied.	<a href="#">PB-4</a>	D
<b>Automatic transmission "Park" mechanism</b>	Check that the lock release button on the selector lever operates properly and smoothly. On a fairly steep hill check that the vehicle is held securely with the selector lever in the P position without applying the brakes.	—	E
<b>UNDER THE HOOD AND VEHICLE</b>			
The maintenance items listed here should be checked periodically (e.g. each time you check the engine oil or refuel).			
Item		Reference page	
<b>Windshield washer fluid</b>	Check that there is adequate fluid in the tank.	—	F
<b>Engine coolant level</b>	Check the coolant level when the engine is cold.	<a href="#">CO-11</a>	G
<b>Radiator and hoses</b>	Check the front of the radiator and clean off any dirt, insects, leaves, etc., that may have accumulated. Make sure the hoses have no cracks, deformation, deterioration or loose connections.	—	H
<b>Brake fluid level</b>	Make sure that the brake fluid level is between the "MAX" and "MIN" lines on the reservoir.	<a href="#">BR-16</a>	I
<b>Battery</b>	Check the fluid level in each cell. It should be between the "MAX" and "MIN" lines. Vehicles operated in high temperatures or under severe conditions require frequent checks of the battery fluid level.	—	J
<b>Engine drive belt</b>	Make sure that no belt is frayed, worn, cracked or oily.	<a href="#">EM-13</a>	
<b>Engine oil level</b>	Check the level on the dipstick after parking the vehicle on a level spot and turning off the engine.	<a href="#">LU-8</a>	K
<b>Power steering fluid level and lines</b>	Check the level on the reservoir with the engine off. Check the lines for improper attachment, leaks, cracks, etc.	<a href="#">MA-29</a>	
<b>Automatic transmission fluid level</b>	Check the level on the dipstick after putting the selector lever in "P" with the engine idling.	<a href="#">TM-167</a>	L
<b>Exhaust system</b>	Make sure there are no loose supports, cracks or holes. If the sound of the exhaust seems unusual or there is a smell of exhaust fumes, immediately locate the trouble and correct it.	<a href="#">EX-4</a>	M
<b>Underbody</b>	The underbody is frequently exposed to corrosive substances such as those used on icy roads or to control dust. It is very important to remove these substances, otherwise rust will form on the floor pan, frame, fuel lines and around the exhaust system. At the end of winter, the underbody should be thoroughly flushed with plain water, being careful to clean those areas where mud and dirt can easily accumulate.	—	N
<b>Fluid leaks</b>	Check under the vehicle for fuel, oil, water or other fluid leaks after the vehicle has been parked for a while. Water dripping from the air conditioner after use is normal. If you should notice any leaks or gasoline fumes are evident, check for the cause and correct it immediately.	—	O

MA

# PERIODIC MAINTENANCE

< ON-VEHICLE MAINTENANCE >

## PERIODIC MAINTENANCE

### Introduction of Periodic Maintenance

INFOID:000000005387346

Two different maintenance schedules are provided, and should be used, depending upon the conditions in which the vehicle is mainly operated. **After 60,000 miles (96,000 km) or 48 months, continue the periodic maintenance at the same mileage or time intervals, whichever comes first.**

Schedule 1	Follow Periodic Maintenance Schedule 1 if your driving habits frequently includes one or more of the following driving conditions: <ul style="list-style-type: none"> <li>• Repeated short trips of less than 5 miles (8 km).</li> <li>• Repeated short trips of less than 10 miles (16 km) with outside temperatures remaining below freezing.</li> <li>• Operating in hot weather in stop-and-go "rush hour" traffic.</li> <li>• Extensive idling and/or low speed driving for long distances, such as police, taxi or door-to-door delivery use.</li> <li>• Driving in dusty conditions.</li> <li>• Driving on rough, muddy, or salt spread roads.</li> <li>• Towing a trailer or using a camper or car-top carrier.</li> </ul>	Emission Control System Maintenance	<a href="#">MA-6</a>
		Chassis and Body Maintenance	<a href="#">MA-6</a>
Schedule 2	Follow Periodic Maintenance Schedule 2 if none of the driving conditions shown in Schedule 1 apply to the driving habits.	Emission Control System Maintenance	<a href="#">MA-8</a>
		Chassis and Body Maintenance	<a href="#">MA-8</a>

### Maintenance for off-road driving (4WD only)

After driving the vehicle off-road through sand, mud, or water; more frequent maintenance may be required for the following items:

- ▲ Brake pads and rotors
- ▲ Brake lines and hoses
- ▲ Rear final drive oil, transmission fluid, and transfer fluid
- ▲ Steering linkage
- ▲ Drive shafts
- ▲ Engine air cleaner filter

### Schedule 1

INFOID:000000005387347

## EMISSION CONTROL SYSTEM MAINTENANCE

Abbreviations: R = Replace. I = Inspect. Correct or replace if necessary. [ ]: At the mileage intervals only

MAINTENANCE OPERATION		MAINTENANCE INTERVAL								Reference Section - Page or - Content Title
Perform at number of miles, kilometers or months, whichever comes first.	Miles x 1,000 (km x 1,000) Months	3.75 (6) 3	7.50 (12) 6	11.25 (18) 9	15 (24) 12	18.75 (30) 15	22.5 (36) 18	26.25 (42) 21	30 (48) 24	
Drive belts	NOTE (1)									<a href="#">EM-13</a>
Air cleaner filter	NOTE (2)								[R]	<a href="#">MA-15</a>
EVAP vapor lines									I*	<a href="#">MA-19</a>
Fuel lines									I*	<a href="#">FL-5</a>
Fuel filter	NOTE (3)									<a href="#">MA-15</a>
Engine coolant	NOTE (4)									<a href="#">CO-10</a>
Engine oil		R	R	R	R	R	R	R	R	<a href="#">LU-9</a>
Engine oil filter		R	R	R	R	R	R	R	R	<a href="#">MA-16</a>
Spark plugs (IRIDIUM - TIPPED type)		Replace every 105,000 miles (169,000 km).								<a href="#">MA-18</a>
Intake and exhaust valve clearance*	NOTE (5)									<a href="#">EM-109</a>

# PERIODIC MAINTENANCE

## < ON-VEHICLE MAINTENANCE >

MAINTENANCE OPERATION		MAINTENANCE INTERVAL								Reference Section - Page or - Content Title
		Miles x 1,000 (km x 1,000) Months	33.75 (54) 27	37.5 (60) 30	41.25 (66) 33	45 (72) 36	48.75 (78) 39	52.5 (84) 42	56.25 (90) 45	
Perform at number of miles, kilometers or months, whichever comes first.										
Drive belts	NOTE (1)								I*	<a href="#">EM-13</a>
Air cleaner filter	NOTE (2)								[R]	<a href="#">MA-15</a>
EVAP vapor lines									I*	<a href="#">MA-19</a>
Fuel lines									I*	<a href="#">FL-5</a>
Fuel filter	NOTE (3)									<a href="#">MA-15</a>
Engine coolant	NOTE (4)								R*	<a href="#">CO-11</a>
Engine oil		R	R	R	R	R	R	R	R	<a href="#">LU-9</a>
Engine oil filter		R	R	R	R	R	R	R	R	<a href="#">MA-16</a>
Spark plugs (IRIDIUM - TIPPED type)		Replace every 105,000 miles (169,000 km).								<a href="#">MA-18</a>
Intake and exhaust valve clearance*	NOTE (5)									<a href="#">EM-109</a>

(1) After 60,000 miles (96,000 km) or 48 months, inspect every 15,000 miles (24,000 km) or 12 months. Replace the drive belts if found damaged or if the auto belt tensioner reading reaches the maximum limit.

(2) If operating mainly in dusty conditions, more frequent maintenance may be required.

(3) Maintenance-free item. For service procedures, go to the FL section.

(4) After 60,000 miles (96,000 km) or 48 months, replace every 30,000 miles (48,000 km) or 24 months.

(5) Periodic maintenance is not required. However, if valve noise increases, inspect valve clearance.

\* Maintenance items and intervals with "\*" are recommended by NISSAN for reliable vehicle operation. The owner need not perform such maintenance in order to maintain the emission warranty or manufacturer recall liability. Other maintenance items and intervals are required.

## CHASSIS AND BODY MAINTENANCE

Abbreviations: R = Replace. I = Inspect. Correct or replace if necessary. L = Lubricate. [ ] : At the mileage intervals only.

MAINTENANCE OPERATION		MAINTENANCE INTERVAL								Reference Section - Page or - Content Title
		Miles x 1,000 (km x 1,000) Months	3.75 (6) 3	7.5 (12) 6	11.25 (18) 9	15 (24) 12	18.75 (30) 15	22.5 (36) 18	26.25 (42) 21	
Perform at number of miles, kilometers or months, whichever comes first.										
Brake lines and cables					I				I	<a href="#">MA-28</a>
Brake pads and rotors			I		I		I		I	<a href="#">MA-28</a>
Automatic transmission fluid, transfer fluid and differential gear oil	NOTE (1)				I				I	<a href="#">TM-167,</a> <a href="#">DLN-90,</a> <a href="#">DLN-162,</a> <a href="#">DLN-192,</a> <a href="#">DLN-250</a>
Steering gear and linkage, axle and suspension parts			I		I		I		I	<a href="#">MA-29,</a> <a href="#">MA-30</a>
Tire Rotation	NOTE (2)									<a href="#">WT-46,</a> "Adjustment"
Drive shaft boots and propeller shaft (4WD)			I		I		I		I	<a href="#">MA-25</a>
Exhaust system			I		I		I		I	<a href="#">EX-4</a>
In-cabin microfilter					R				R	<a href="#">MA-20</a>

# PERIODIC MAINTENANCE

## < ON-VEHICLE MAINTENANCE >

MAINTENANCE OPERATION	Miles x 1,000 (km x 1,000) Months	MAINTENANCE INTERVAL								Reference Section - Page or - Content Title
		33.75 (54) 27	37.5 (60) 30	41.25 (66) 33	45 (72) 36	48.75 (78) 39	52.5 (84) 42	56.25 (90) 45	60 (96) 48	
Perform at number of miles, kilometers or months, whichever comes first.										
Brake lines and cables					I				I	<a href="#">MA-28</a>
Brake pads and rotors			I		I		I		I	<a href="#">MA-28</a>
Automatic transmission fluid, transfer fluid and differential gear oil	NOTE (1)				I				I	<a href="#">MA-21</a> , <a href="#">MA-24</a> , <a href="#">MA-25</a> , <a href="#">MA-26</a>
Steering gear and linkage, axle and suspension parts			I		I		I		I	<a href="#">MA-29</a> , <a href="#">MA-30</a>
Tire Rotation	NOTE (2)									<a href="#">WT-46</a>
Drive shaft boots and propeller shaft (4WD)			I		I		I		I	<a href="#">MA-25</a>
Exhaust system			I		I		I		I	<a href="#">EX-4</a>
In-cabin microfilter					R				R	<a href="#">MA-20</a>

(1) If towing a trailer, or using a camper or car-top carrier, or driving on rough or muddy roads, change (not just inspect) oil/fluid at every 30,000 miles (48,000 km) or 24 months. **Using automatic transmission fluid other than Genuine NISSAN Matic S ATF or Matic J ATF will cause deterioration in driveability and automatic transmission durability, and may damage the automatic transmission, which is not covered by the NISSAN new vehicle limited warranty.**

(2) Refer to "Tire rotation" under the "General maintenance" heading earlier in this section.

## Schedule 2

INFOID:000000005387348

## EMISSION CONTROL SYSTEM MAINTENANCE

Abbreviations: R = Replace. I = Inspect. Correct or replace if necessary. [ ]: At the mileage intervals only

MAINTENANCE OPERATION	Miles x 1,000 (km x 1,000) Months	MAINTENANCE INTERVAL								Reference Section - Page or - Content Title
		7.5 (12) 6	15 (24) 12	22.5 (36) 18	30 (48) 24	37.5 (60) 30	45 (72) 36	52.5 (84) 42	60 (96) 48	
Perform at number of miles, kilometers or months, whichever comes first.										
Drive belts	NOTE (1)								I*	<a href="#">MA-12</a>
Air cleaner filter					[R]				[R]	<a href="#">MA-15</a>
EVAP vapor lines					I*				I*	<a href="#">MA-19</a>
Fuel lines					I*				I*	<a href="#">MA-15</a>
Fuel filter	NOTE (2)									<a href="#">MA-15</a>
Engine coolant	NOTE (3)								R*	<a href="#">MA-12</a>
Engine oil (Except FFV models)		R	R	R	R	R	R	R	R	<a href="#">MA-16</a>
Engine oil (For FFV models)		Replace every 3,750 miles (6,000 km) or 3 months.								<a href="#">LU-9</a>
Engine oil filter (Except FFV models)		R	R	R	R	R	R	R	R	<a href="#">MA-16</a>
Engine oil filter (For FFV models)		Replace every 3,750 miles (6,000 km) or 3 months.								<a href="#">MA-16</a>
Spark plugs (IRIDIUM-TIPPED type)		Replace every 105,000 miles (169,000 km).								<a href="#">MA-18</a>
Intake and exhaust valve clearance*	NOTE (4)									<a href="#">EM-109</a> , "Standard and Limit"

(1) After 60,000 miles (96,000 km) or 48 months, inspect every 15,000 miles (24,000 km) or 12 months. Replace the drive belts if found damaged or if the auto belt tensioner reading reaches the maximum limit.

(2) Maintenance-free item. For service procedures, go to FL section.

(3) After 60,000 miles (96,000 km) or 48 months, replace every 30,000 miles (48,000 km) or 24 months.

(4) Periodic maintenance is not required. However, if valve noise increases, inspect valve clearance.



# PERIODIC MAINTENANCE

## < ON-VEHICLE MAINTENANCE >

\* Maintenance items and intervals with “\*” are recommended by NISSAN for reliable vehicle operation. The owner need not perform such maintenance in order to maintain the emission warranty or manufacturer recall liability. Other maintenance items and intervals are required.

## CHASSIS AND BODY MAINTENANCE

Abbreviations: R = Replace. I = Inspect. Correct or replace if necessary. L = Lubricate. [ ]: At the mileage interval only.

MAINTENANCE OPERATION		MAINTENANCE INTERVAL								Reference Section - Page or - Content Title
Perform at number of miles, kilometers or months, whichever comes first.	Miles x 1,000 (km x 1,000) Months	7.5 (12) 6	15 (24) 12	22.5 (36) 18	30 (48) 24	37.5 (60) 30	45 (72) 36	52.5 (84) 42	60 (96) 48	
Brake lines and cables			I		I		I		I	<a href="#">MA-28</a>
Brake pads and rotors			I		I		I		I	<a href="#">MA-28</a>
Automatic transmission fluid, transfer fluid and differential gear oil	NOTE (1)		I		I		I		I	<a href="#">MA-21</a> , <a href="#">MA-24</a> <a href="#">MA-25</a> , <a href="#">MA-26</a>
Steering gear and linkage, axle and suspension parts.					I				I	<a href="#">MA-29</a> , <a href="#">MA-30</a>
Tire rotation	NOTE (2)									<a href="#">WT-46</a>
Drive shaft boots and propeller shaft (4WD)			I		I		I		I	<a href="#">MA-25</a>
Exhaust system					I				I	<a href="#">EX-4</a>
In-cabin microfilter			R		R		R		R	<a href="#">MA-20</a>

(1) Using automatic transmission fluid other than Genuine NISSAN Matic S ATF or Matic J ATF will cause deterioration in drivability and automatic transmission durability, and may damage the automatic transmission, which is not covered by the NISSAN new vehicle limited warranty.

(2) Refer to “Tire rotation” under the “General maintenance” heading earlier in this section.

# RECOMMENDED FLUIDS AND LUBRICANTS

< ON-VEHICLE MAINTENANCE >

## RECOMMENDED FLUIDS AND LUBRICANTS

### Fluids and Lubricants

INFOID:000000005387349

Description		Capacity (Approximate)			Recommended Fluids/Lubricants
		Metric	US measure	Imp measure	
Fuel	Short wheel-base	105.8 ℓ	28 gal	23 1/4 gal	Unleaded gasoline with an octane rating of at least 87 AKI (RON 91), or E-85 Ethanol fuel for Flexible Fuel Vehicles (FFV) *7
	Long wheel-base	140 ℓ	37 gal	30 3/4 gal	
Engine oil Drain and refill	With oil filter change	6.5 ℓ	6 7/8 qt	5 3/4 qt	<ul style="list-style-type: none"> <li>• API Certification Mark*1</li> <li>• Viscosity SAE 5W-30</li> </ul>
	Without oil filter change	6.2 ℓ	6 1/2 qt	5 1/2 qt	
Dry engine (engine overhaul)		7.6 ℓ	8 qt	6 3/4 qt	
Cooling system	With reservoir at MAX level	12.2 ℓ	12 1/8 qt	10 3/4 qtl	Genuine NISSAN Long Life Anti-freeze coolant or equivalent
Automatic transmission fluid (ATF)		10.6 ℓ	11 1/4 qt	9 3/8 qt	Genuine NISSAN Matic S ATF*2
Rear differential gear oil		2.01 ℓ	4 1/4 pt	3 1/2 pt	Genuine NISSAN different oil Synthetic 75W-140 or API GL-5 Synthetic Gear Oil, Viscosity SAE 75W-140 *6.
Transfer fluid		2.0 ℓ	2 1/8 qt	1 3/4 qt	Genuine NISSAN Matic D ATF recommended *9
Front differential gear oil		1.6 ℓ	3 3/8 pt	2 7/8 pt	Genuine NISSAN Differential Oil Hypoid Super GL-5 80W-90 or API GL-5 Viscosity SAE 80W-90 *8
Power steering fluid (PSF)		1.0 ℓ	1 1/8 qt	7/8 qt	Genuine NISSAN PSF or equivalent*3
Brake fluid		—	—	—	Genuine NISSAN Super Heavy Duty Brake Fluid *4 or equivalent, DOT 3
Multi-purpose grease		—	—	—	NLGI No. 2 (lithium soap base)
Brake grease		—	—	—	PBC (poly butyl cuprysil) grease or equivalent
Windshield washer fluid		4.5 ℓ	4 3/4 qt	4 qt	Genuine NISSAN Windshield Washer Concentrate Cleaner & Anti-freeze or equivalent
Air conditioning system refrigerant		0.70 ± 0.05 kg	1.54 ± 0.11 lb	1.54 ± 0.11 lb	HFC-134a (R-134a)*5
Air conditioning system oil		200 m ℓ	6.8 fl oz	7.0 fl oz	NISSAN A/C System Oil Type S or equivalent *5

\*1: For further details, refer to [MA-11, "Engine Oil Recommendation"](#).

\*2: If Genuine NISSAN Matic S ATF is not available, Genuine Matic J ATF may also be used. Using automatic transmission fluid other than Genuine NISSAN Matic S ATF or Matic J ATF will cause deterioration in driveability and automatic transmission durability, and may damage the automatic transmission, which is not covered by the NISSAN new vehicle limited warranty.

\*3: DEXRON™ VI type ATF may also be used.

\*4: Available in mainland U.S.A. through a NISSAN dealer.

\*5: For further details, see "Air conditioner specification label".

\*6: See a NISSAN dealer for service for synthetic oil.

\*7: For further details, refer to [GI-26, "General Precautions"](#).

\*8: For hot climates, Viscosity SAE 90 is suitable for ambient temperatures above 0°C (32°F).

\*9: Using fluid other than Genuine NISSAN Matic D ATF will cause deterioration in driveability and transfer durability, and may damage the transfer, which is not covered by the NISSAN new vehicle limited warranty.

# RECOMMENDED FLUIDS AND LUBRICANTS

< ON-VEHICLE MAINTENANCE >

## Engine Oil Recommendation

INFOID:000000005387350

NISSAN recommends the use of an energy conserving oil in order to improve fuel economy. Select only engine oils that meet the American Petroleum Institute (API) certification and International Lubricant Standardization and Approval Committee (ILSAC) certification and SAE viscosity standard (2). These oils have the API certification mark (1) on the front of the container. Oils which do not have the specified quality label should not be used as they could cause engine damage.

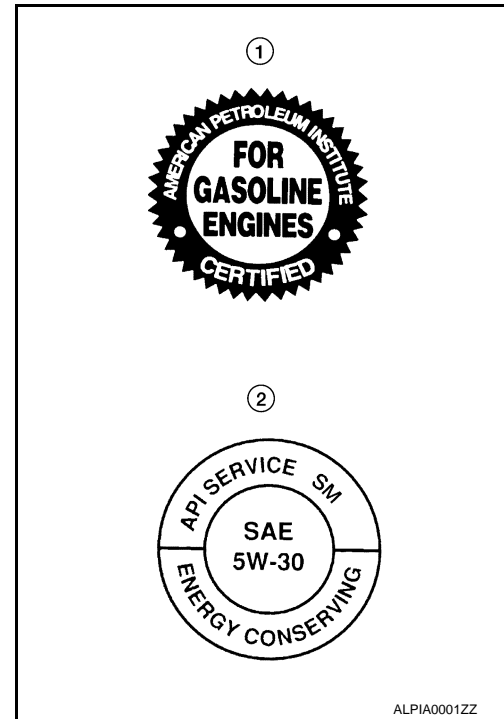

### ANTI-FREEZE COOLANT MIXTURE RATIO

The engine cooling system is filled at the factory with a high-quality, long life, year-round, anti-freeze coolant solution. The anti-freeze solution contains rust and corrosion inhibitors. Therefore, additional cooling system additives are not necessary.

For outside temperatures down to:		Anti-freeze coolant mixture ratio	
° C	° F	Genuine NISSAN Long Life Anti-freeze coolant	Demineralized water or distilled water
- 35°	- 30°	50 %	50 %

#### CAUTION:

- When adding or replacing coolant, be sure to use only Genuine NISSAN Long Life Anti-freeze coolant or equivalent with the proper mixture ratio of 50% anti-freeze and 50% demineralized water or distilled water.
- Other types of coolant solutions may damage your cooling system.

# ENGINE MAINTENANCE

< ON-VEHICLE MAINTENANCE >

## ENGINE MAINTENANCE

### Checking Drive Belts

INFOID:000000005713665

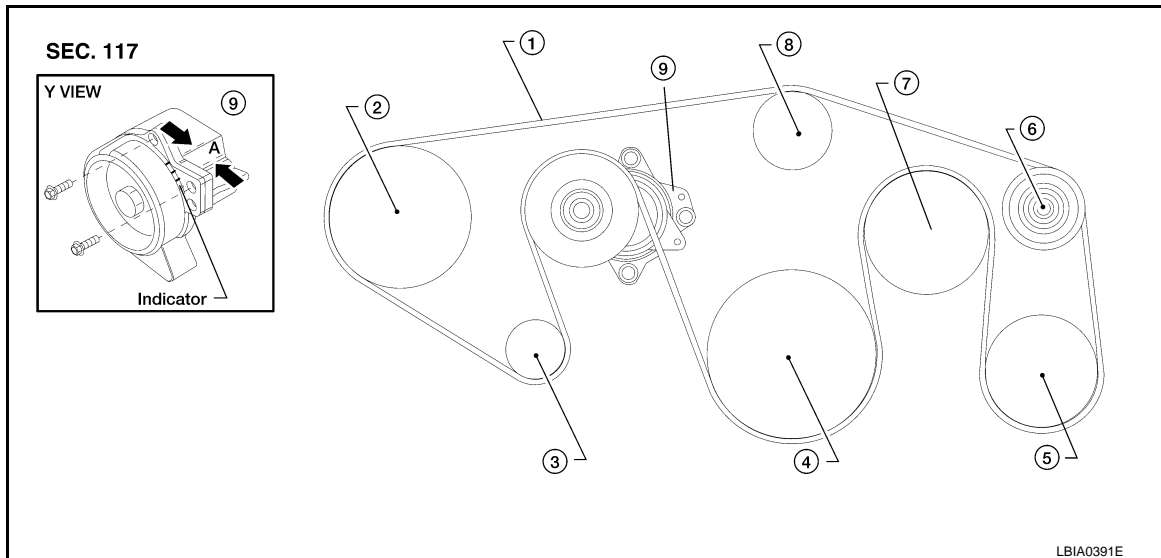

- |                            |                               |                              |
|----------------------------|-------------------------------|------------------------------|
| 1. Drive belt              | 2. Power steering pump pulley | 3. Generator pulley          |
| 4. Crankshaft pulley       | 5. A/C compressor             | 6. Idler pulley              |
| 7. Cooling fan pulley      | 8. Water pump pulley          | 9. Drive belt auto tensioner |
| A. Allowable working range |                               |                              |

#### **WARNING:**

**Be sure to perform when the engine is stopped.**

1. Remove air duct and resonator assembly when inspecting drive belt.
2. Make sure that indicator (single line notch) of each auto tensioner is within the allowable working range (between three line notches).

#### **NOTE:**

- Check the drive belt auto tensioner indication when the engine is cold.
  - The indicator notch is located on the moving side of the drive belt auto tensioner.
3. Visually check entire belt for wear, damage or cracks.
  4. If the indicator is out of allowable working range or belt is damaged, replace the belt. Refer to [MA-12](#).

#### DRIVE BELT TENSION

There is no manual drive belt tension adjustment. The drive belt tension is automatically adjusted by the drive belt auto tensioner.

### Changing Engine Coolant

INFOID:000000005713666

#### **WARNING:**

- To avoid being scalded, never change the coolant when the engine is hot.
- Wrap a thick cloth around the cap to carefully remove the cap. First, turn the cap a quarter of a turn to release any built-up pressure, then push down and turn the cap all the way to remove it.

#### DRAINING ENGINE COOLANT

1. Turn ignition switch ON and set temperature control lever all the way to HOT position or the highest temperature position. Wait 10 seconds and turn ignition switch OFF.
2. Remove the engine under cover or skid plate. Refer to [EXT-13. "Removal and Installation"](#).

# ENGINE MAINTENANCE

## < ON-VEHICLE MAINTENANCE >

3. Open the radiator drain plug at the bottom of the radiator, and remove the radiator filler cap. This is the only step required when partially draining the cooling system (radiator only).

**CAUTION:**

**Do not to allow the coolant to contact the drive belts.**

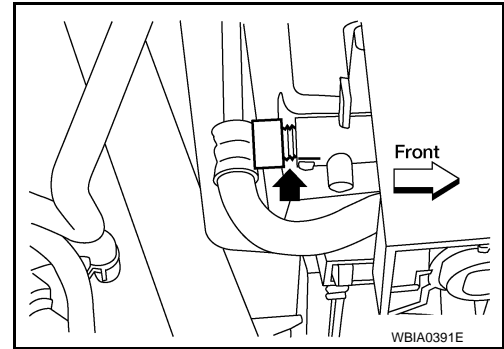

4. When draining all of the coolant in the system for engine removal or repair, it is necessary to drain the cylinder block. Remove the RH cylinder block drain plug to drain the right bank and the oil cooler hose to drain the left bank as shown.

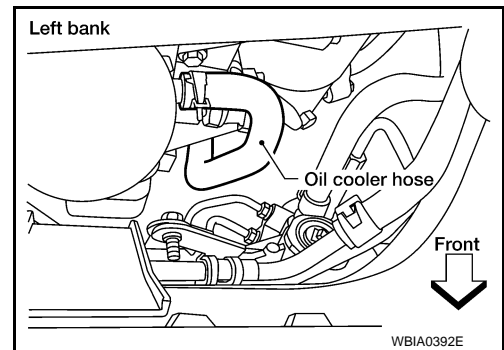
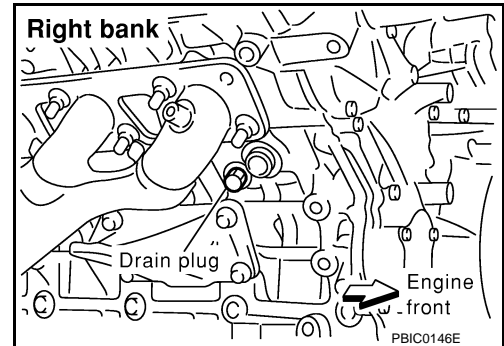

5. Remove the reservoir tank to drain the engine coolant, then clean the reservoir tank before installing it.
6. Check the drained coolant for contaminants such as rust, corrosion or discoloration. If the coolant is contaminated, flush the engine cooling system. Refer to [MA-12. "Changing Engine Coolant"](#).

## REFILLING ENGINE COOLANT

1. Close the radiator drain plug. Install the reservoir tank, cylinder block drain plug, and the oil cooler hose, if removed for a total system drain or for engine removal or repair.
  - The radiator must be completely empty of coolant and water.
  - Apply sealant to the threads of the cylinder block drain plug. Use Genuine High Performance Thread Sealant or equivalent. Refer to [GI-14. "Recommended Chemical Products and Sealants"](#).

**Radiator drain plug** : Refer to [CO-15](#).

**RH cylinder block drain plug** : Refer to [MA-12](#).

2. Set the vehicle heater controls to the full HOT and heater ON position. Turn the vehicle ignition ON with the engine OFF as necessary to activate the heater mode.
3. Remove the vented reservoir cap and replace it with a non-vented reservoir cap before filling the cooling system.

# ENGINE MAINTENANCE

## < ON-VEHICLE MAINTENANCE >

4. Install the Tool by installing the radiator cap adapter onto the radiator neck opening. Then attach the gauge body assembly with the refill tube and the venturi assembly to the radiator cap adapter.

**Tool number** : KV991J0070 (J-45695)

5. Insert the refill hose into the coolant mixture container that is placed at floor level. Make sure the ball valve is in the closed position.
  - Use Genuine NISSAN Long Life Anti-freeze coolant or equivalent, mixed 50/50 with distilled water or demineralized water. Refer to [MA-10, "Fluids and Lubricants"](#).

**Cooling system capacity (with reservoir)** : Refer to [CO-24, "Standard and Limit"](#).

6. Install an air hose to the venturi assembly, the air pressure must be within specification.

**Compressed air supply pressure** : 549 - 824 kPa (5.6 - 8.4 kg/cm<sup>2</sup>, 80 - 119 psi)

### CAUTION:

**The compressed air supply must be equipped with an air dryer.**

7. The vacuum gauge will begin to rise and there will be an audible hissing noise. During this process open the ball valve on the refill hose slightly. Coolant will be visible rising in the refill hose. Once the refill hose is full of coolant, close the ball valve. This will purge any air trapped in the refill hose.
8. Continue to draw the vacuum until the gauge reaches 28 inches of vacuum. The gauge may not reach 28 inches in high altitude locations, refer to the vacuum specifications based on the altitude above sea level.

Altitude above sea level	Vacuum gauge reading
0 - 100 m (328 ft)	: 28 inches of vacuum
300 m (984 ft)	: 27 inches of vacuum
500 m (1,641 ft)	: 26 inches of vacuum
1,000 m (3,281 ft)	: 24 - 25 inches of vacuum

9. When the vacuum gauge has reached the specified amount, disconnect the air hose and wait 20 seconds to see if the system loses any vacuum. If the vacuum level drops, perform any necessary repairs to the system and repeat steps 6 - 8 to bring the vacuum to the specified amount. Recheck for any leaks.
10. Place the coolant container (with the refill hose inserted) at the same level as the top of the radiator. Then open the ball valve on the refill hose so the coolant will be drawn up to fill the cooling system. The cooling system is full when the vacuum gauge reads zero.

### CAUTION:

**Do not allow the coolant container to get too low when filling, to avoid air from being drawn into the cooling system.**

11. Remove the Tool from the radiator neck opening and install the radiator cap.
12. Remove the non-vented reservoir cap.
13. Fill the cooling system reservoir tank to the specified level. Run the engine to warm up the cooling system and top up the system as necessary before installing the vented reservoir cap.

## FLUSHING COOLING SYSTEM

1. Drain the water from the engine cooling system. Refer to [MA-12, "Changing Engine Coolant"](#).

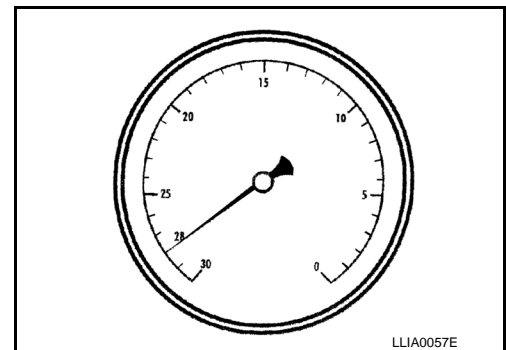
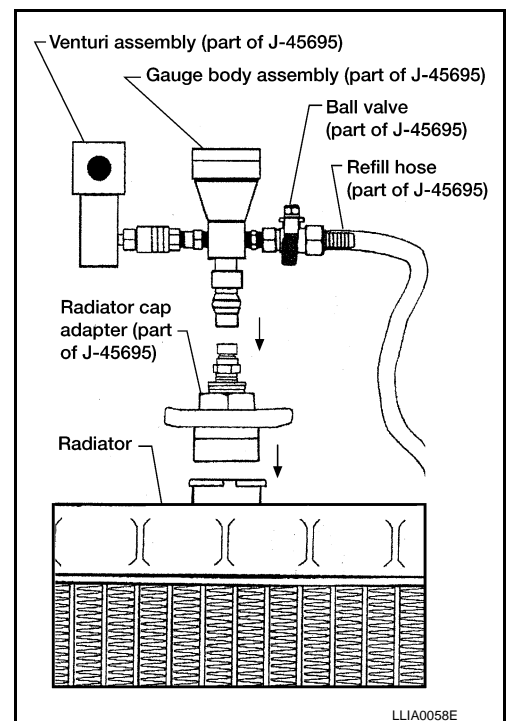

# ENGINE MAINTENANCE

## < ON-VEHICLE MAINTENANCE >

2. Fill the radiator and the reservoir tank (to the "MAX" line), with water. Reinstall the radiator cap and leave the vented reservoir cap off.
3. Run the engine until it reaches normal operating temperature.
4. Press the engine accelerator two or three times under no-load.
5. Stop the engine and wait until it cools down.
6. Drain the water from the engine cooling system. Refer to [MA-12. "Changing Engine Coolant"](#).
7. Repeat steps 2 through 6 until clear water begins to drain from the radiator.

## Checking Fuel Line

INFOID:000000005713667

Inspect fuel lines, fuel filler cap and fuel tank for improper attachment, leaks, cracks, damage, loose connections, chafing or deterioration.

If necessary, repair or replace damaged parts.

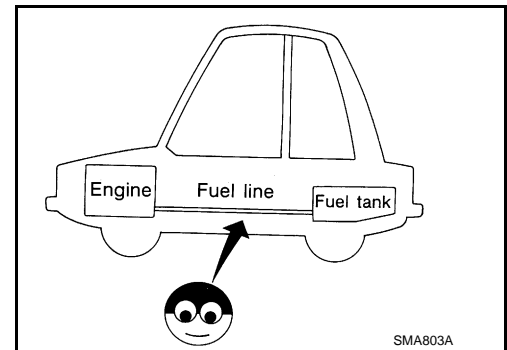

## Changing Fuel Filter

INFOID:000000005387354

The fuel filter is part of the fuel level sensor unit, fuel filter and fuel pump assembly. Refer to [FL-11](#).

### **WARNING:**

**Before replacing the fuel filter, release the fuel pressure from the fuel system. Refer to [EC-481. "Fuel Pressure Check"](#).**

## Changing Engine Air Cleaner Filter

INFOID:000000005387355

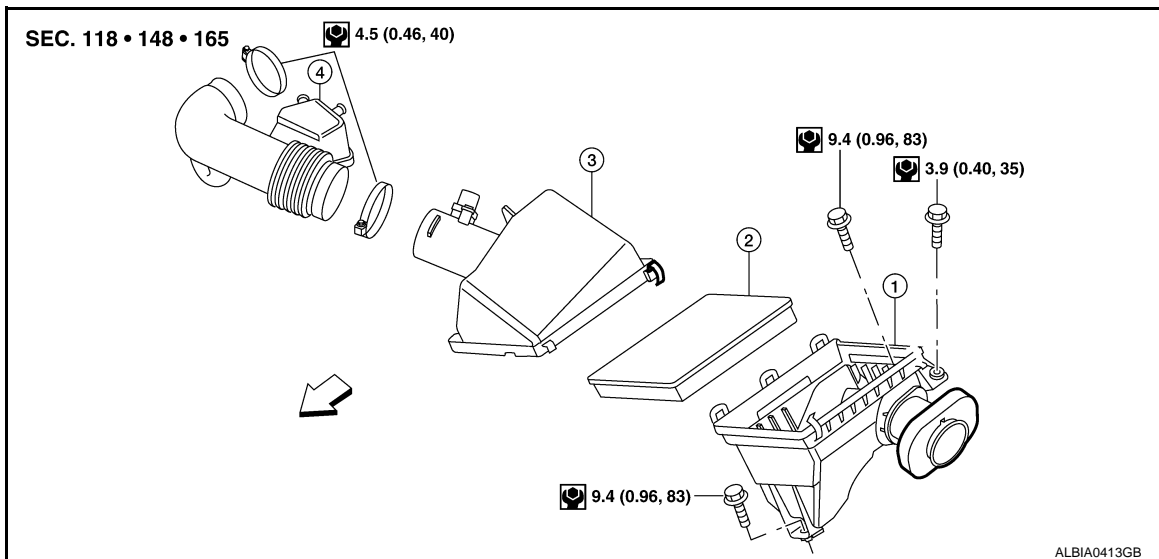

- |                                    |                       |                             |
|------------------------------------|-----------------------|-----------------------------|
| 1. Air cleaner case (lower)        | 2. Air cleaner filter | 3. Air cleaner case (upper) |
| 4. Air duct and resonator assembly | ← Front               |                             |

## REMOVAL

### **NOTE:**

- The viscous paper type filter does not need cleaning between replacement intervals.
- Replace the air filter as necessary for periodic maintenance. Refer to [MA-6. "Introduction of Periodic Maintenance"](#).

1. Remove the air duct and resonator assembly.

# ENGINE MAINTENANCE

## < ON-VEHICLE MAINTENANCE >

2. Remove the air cleaner case (upper).
3. Remove the air cleaner filter from the air cleaner case (lower).

### INSTALLATION

1. Install the new air cleaner filter in the air cleaner case (lower).
2. Install the air cleaner case (upper).
3. Install the air duct and resonator assembly (inlet).

## Changing Engine Oil

INFOID:000000005713668

### WARNING:

- Be careful not to burn yourself, as the engine oil is hot.
- Prolonged and repeated contact with used engine oil may cause skin cancer. Try to avoid direct skin contact with used engine oil. If skin contact is made, wash thoroughly with soap or hand cleaner as soon as possible.

1. Remove engine under cover or skid plate. Refer to [EXT-13, "Removal and Installation"](#).
2. Warm up engine, and check for oil leakage from engine components. Refer to [LU-8, "Inspection"](#).
3. Stop engine and wait for 10 minutes.
4. Loosen oil filler cap, then remove drain plug.
5. Drain engine oil.
6. Install drain plug with new washer.

### CAUTION:

- Be sure to clean drain plug and install with new washer.

**Oil pan drain plug : 34.3 N-m (3.5 kg-m, 25 ft-lb)**

7. Refill with new engine oil. Refer to [MA-10, "Fluids and Lubricants"](#).

Engine oil capacity (Approximate):

		Unit: ℓ (US qt, Imp qt)
Drain and refill	With oil filter change	6.5 (6 7/8, 5 3/4)
	Without oil filter change	6.2 (6 1/2, 5 1/2)
Dry engine (engine overhaul)		7.6 (8, 6 3/4)

### CAUTION:

- The refill capacity depends on the engine oil temperature and drain time. Use these specifications for reference only.
  - Always use the oil level gauge to determine when the proper amount of engine oil is in the engine.
8. Warm up engine and check area around drain plug and oil filter for oil leakage.
  9. Stop engine and wait for 10 minutes.
  10. Check engine oil level. Refer to [LU-8, "Inspection"](#).

## Changing Oil Filter

INFOID:000000005387357

### REMOVAL

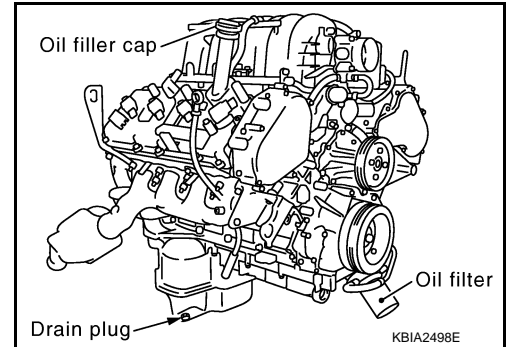



# ENGINE MAINTENANCE

## < ON-VEHICLE MAINTENANCE >

1. Drain the engine oil. Refer to [LU-9. "Changing Engine Oil"](#).
2. Remove the oil filter using Tool.

**Tool number : KV10115801 (J-38956)**

### **WARNING:**

- Be careful not to get burned when the engine and engine oil are hot.

### **CAUTION:**

- The oil filter is provided with a relief valve. Use Genuine NISSAN oil filter or equivalent.
- Be careful not to get burned when the engine and engine oil are hot.
- When removing, prepare a shop cloth to absorb any engine oil leakage or spillage.
- Do not allow engine oil to adhere to the drive belts.
- Completely wipe off any engine oil that adheres to the engine and the vehicle.

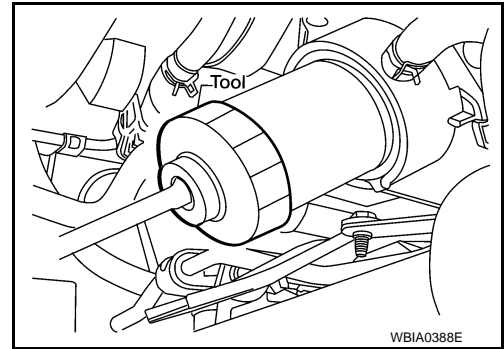

## INSTALLATION

1. Remove foreign materials adhering to the oil filter installation surface.
2. Apply engine oil to the oil seal circumference of the new oil filter.

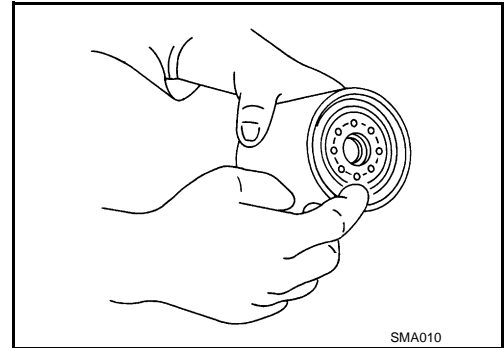

3. Screw the oil filter manually until it touches the installation surface, then tighten it by 2/3 turn. Or tighten to specification.

**Oil filter : 17.7 N·m (1.8 kg·m, 13 ft·lb)**

4. Refill the engine with new engine oil. Refer to [LU-9. "Changing Engine Oil"](#).
5. Inspect the engine for oil leakage. Follow the "INSPECTION AFTER INSTALLATION" procedure.

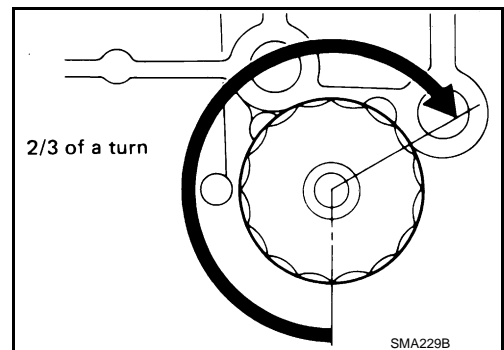

## INSPECTION AFTER INSTALLATION

1. Check the engine oil level. Refer to [LU-8. "Inspection"](#).
2. Start the engine and check for engine oil leakage.
3. Stop the engine and wait for 10 minutes.
4. Check the engine oil level and add engine oil as required.

A  
B  
C  
D  
E  
F  
G  
H  
I  
J  
K  
L  
M  
N  
O

MA

# ENGINE MAINTENANCE

< ON-VEHICLE MAINTENANCE >

## Changing Spark Plugs

INFOID:000000005387358

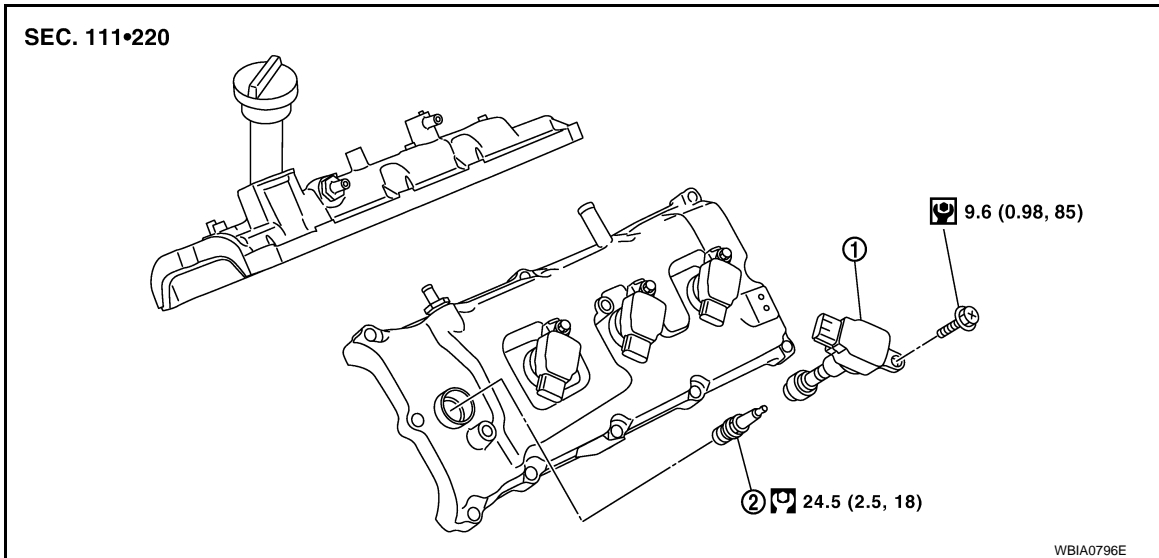

1. Ignition coil
2. Spark plug

### REMOVAL

1. Remove engine room cover using power tool. Refer to [EM-24, "Removal and Installation"](#).
2. Remove ignition coil. Refer to [EM-37, "Removal and Installation"](#).
3. Remove spark plug using suitable tool.

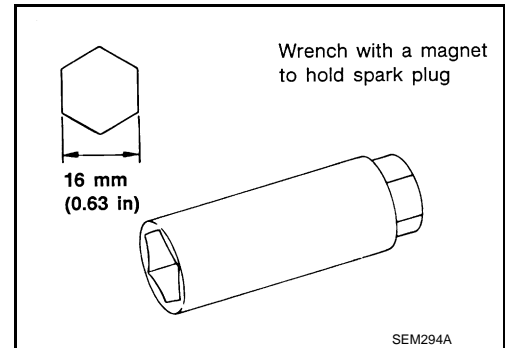

### INSPECTION AFTER REMOVAL

- Do not use a wire brush for cleaning.
- If plug tip is covered with carbon, spark plug cleaner may be used.

#### Cleaner air pressure:

Less than 588 kPa (5.9 bar, 6 kg/cm<sup>2</sup>, 85 psi)

#### Cleaning time:

Less than 20 seconds

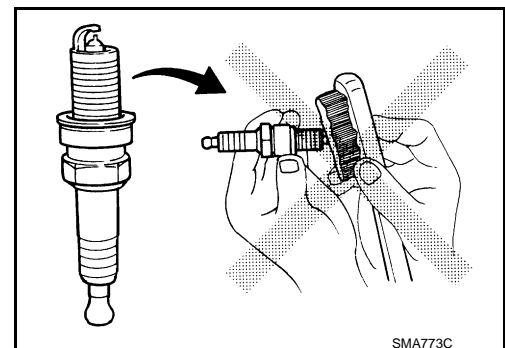

# ENGINE MAINTENANCE

## < ON-VEHICLE MAINTENANCE >

- Checking and adjusting plug gap is not required between change intervals.

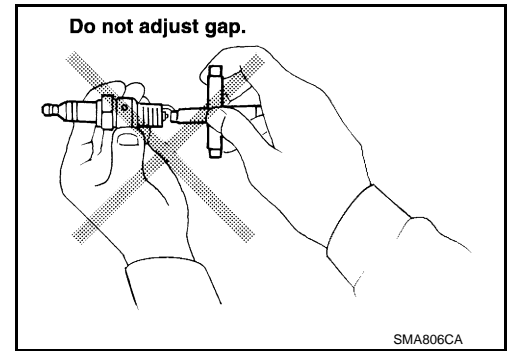

## INSTALLATION

Installation is in the reverse order of removal.

### Spark Plug Types

Make	NGK	
Model	Standard model	FFV model
Standard type	DILFR5A-11	DILFR5A-11D
Gap (Nominal)	1.1 mm (0.043 in)	1.1 mm (0.043)

### **CAUTION:**

**Do not drop or shock spark plug.**

## Checking EVAP Vapor Line

INFOID:000000005387359

1. Visually inspect the EVAP vapor lines for improper attachment, cracks, damage, loose connections, chafing, or deterioration.
2. Inspect the vacuum relief valve of the fuel tank filler cap for clogging and sticking. Refer to [EC-483. "How to Detect Fuel Vapor Leakage"](#).

A  
B  
C  
D  
E  
F  
G  
H  
I  
J  
K  
L  
M  
N  
O

MA

# CHASSIS AND BODY MAINTENANCE

< ON-VEHICLE MAINTENANCE >

## CHASSIS AND BODY MAINTENANCE

### Changing In-cabin Microfilter

INFOID:000000005387360

#### REPLACEMENT PROCEDURE

1. Remove the two lower glove box hinge pins to remove the glove box from the instrument panel and let it hang from the cord.

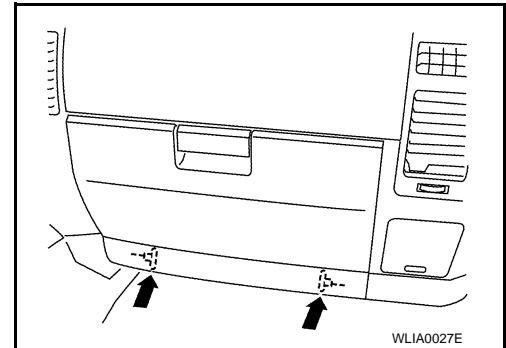

2. Remove the screw and remove the in-cabin microfilter cover.
3. Remove the in-cabin microfilters from the heater and cooling unit assembly housing.

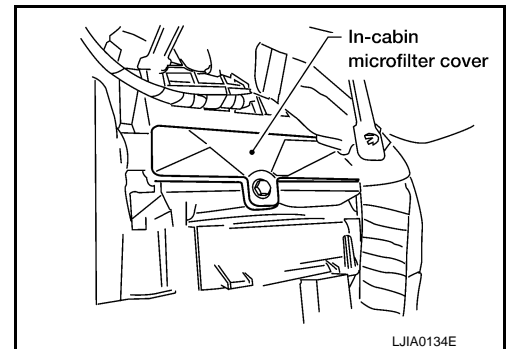

4. Insert the first new in-cabin microfilter into the heater and cooling unit assembly housing and slide it over to the right. Insert the second new in-cabin microfilter into the heater and cooling unit assembly housing.

**NOTE:**

The in-cabin microfilters are marked with air flow arrows. The end of the microfilter with the arrow should face the rear of the vehicle. The arrows should point downward.

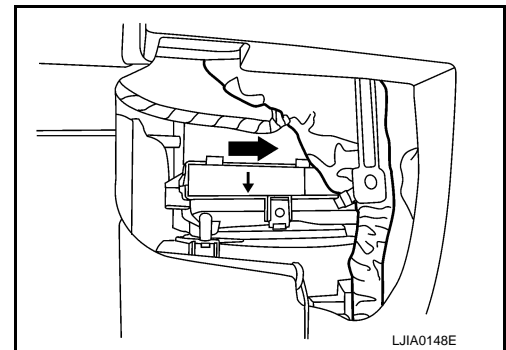

5. Install the in-cabin microfilter cover.

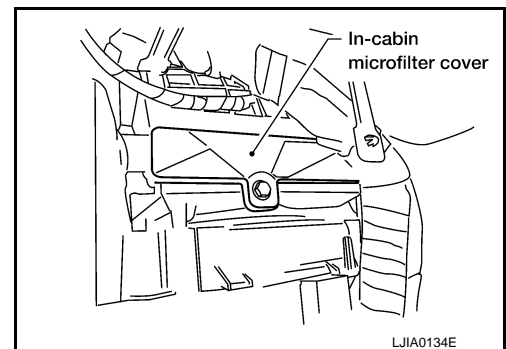

# CHASSIS AND BODY MAINTENANCE

## < ON-VEHICLE MAINTENANCE >

6. Install the lower glove box in the instrument panel and secure it with the two hinge pins.

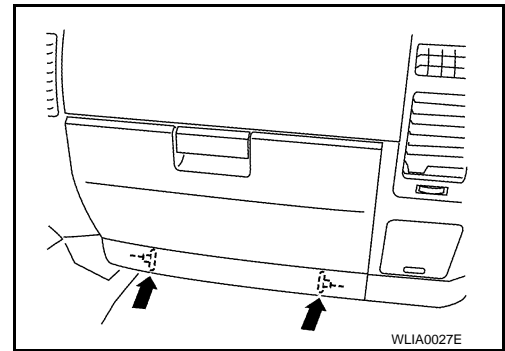

## Checking Exhaust System

INFOID:000000005713691

Check exhaust pipes, muffler and mounting for improper attachment, leaks, cracks, damage or deterioration.

- If anything is found, repair or replace damaged parts.

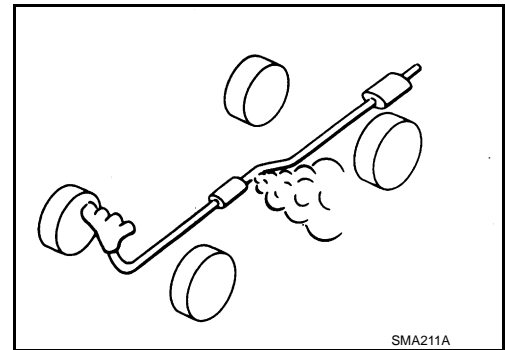

## Checking the A/T Fluid (ATF)

INFOID:000000005713694

### CAUTION:

If using the vehicle for towing, the A/T fluid must be replaced as specified. Refer to [MA-6, "Introduction of Periodic Maintenance"](#).

1. Before driving, the A/T fluid level can be checked at A/T fluid temperatures of 30° to 50° C (86° to 122° F) using the "COLD" range on the A/T fluid level gauge as follows:
  - a. Park the vehicle on a level surface and set the parking brake.
  - b. Start the engine and move the selector lever through each gear position. Shift the selector lever into the "P" position.
  - c. Check the A/T fluid level with the engine idling.
  - d. Remove the A/T fluid level gauge and wipe it clean with a lint-free paper.

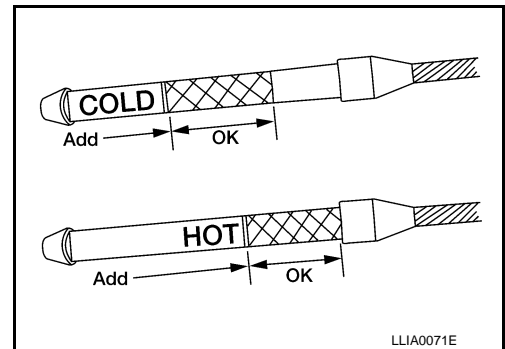

### CAUTION:

When wiping the A/T fluid from the A/T fluid level gauge, always use a lint-free paper, not a cloth.

- e. Re-insert the A/T fluid level gauge into the A/T fluid charging pipe until the cap contacts the top of the A/T fluid charging pipe as shown.

### CAUTION:

To check A/T fluid level, insert the A/T fluid level gauge until the cap contacts the top of the A/T fluid charging pipe, with the gauge reversed from the normal inserted position.

- f. Remove the A/T fluid level gauge and note the A/T fluid level. If the A/T fluid level is at low side of range, add A/T fluid to the transmission through the A/T fluid charging pipe.

### CAUTION:

Do not overfill the transmission with A/T fluid.

- g. Install the A/T fluid level gauge and the A/T fluid level gauge bolt.

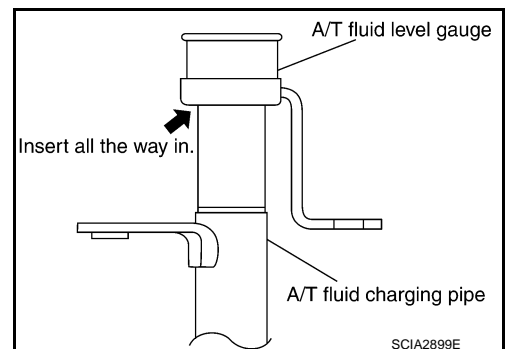

# CHASSIS AND BODY MAINTENANCE

< ON-VEHICLE MAINTENANCE >

**A/T fluid level gauge bolt** : Refer to [TM-207, "Removal and Installation \(2WD\)"](#) or [TM-209, "Removal and Installation \(4WD\)"](#)

2. Warm up the engine and transmission.
3. Check for any A/T fluid leaks.
4. Drive the vehicle to increase the A/T fluid temperature to 80° C (176° F).
5. Allow the A/T fluid temperature to fall to approximately 65°C (149°F). Use the CONSULT-III to monitor the A/T fluid temperature as follows:

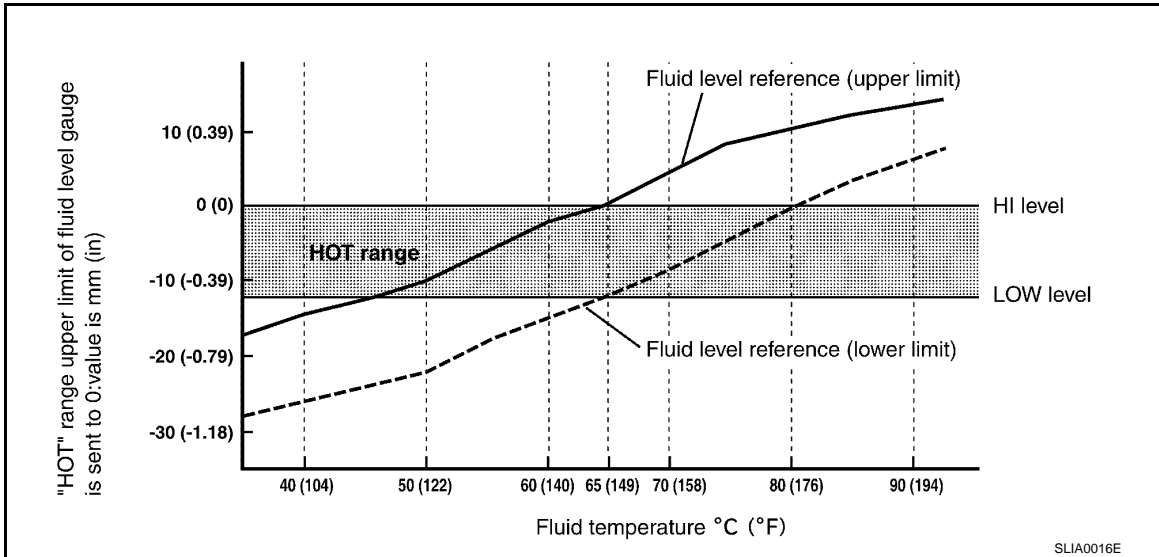

**NOTE:**

The A/T fluid level will be significantly affected by the A/T fluid temperature as shown. Therefore monitor the A/T fluid temperature data using the CONSULT-III.

- a. Connect CONSULT-III to data link connector.
  - b. Select "MAIN SIGNALS" in "DATA MONITOR" mode for "A/T" with CONSULT-III.
  - c. Read out the value of "ATF TEMP 1".
6. Re-check the A/T fluid level at A/T fluid temperatures of approximately 65°C (149°F) using the "HOT" range on the A/T fluid level gauge as shown. The HOT range is between 50° - 80° C (122° - 176° F).

**CAUTION:**

- When wiping the A/T fluid from the A/T fluid level gauge, always use lint-free paper, not a cloth.

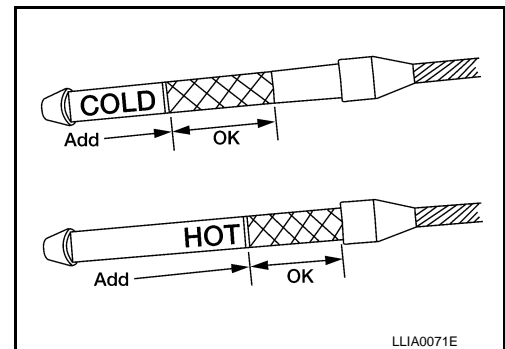

- To check the A/T fluid level, insert the A/T fluid level gauge until the cap contacts the top of the A/T fluid charging pipe, with the gauge reversed from the normal inserted position as shown.

7. Check the A/T fluid condition.
  - If the A/T fluid is very dark or has some burned smell, there may be an internal problem with the transmission. Refer to [TM-171, "A/T Fluid Cooler Cleaning"](#). Flush the transmission cooling system after repairing the transmission.
  - If the A/T fluid contains frictional material (clutches, bands, etc.), replace the radiator and flush the transmission cooler lines using cleaning solvent and compressed air after repairing the transmission.

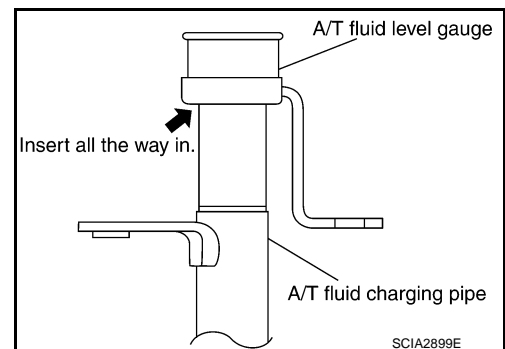

# CHASSIS AND BODY MAINTENANCE

## < ON-VEHICLE MAINTENANCE >

8. Install the A/T fluid level gauge in the A/T fluid charging pipe.
9. Tighten the A/T fluid level gauge bolt to specification.

**A/T fluid level gauge bolt** : Refer to [TM-207, "Removal and Installation \(2WD\)"](#) or [TM-209, "Removal and Installation \(4WD\)"](#)

## Changing the A/T Fluid (ATF)

INFOID:000000005713695

### CAUTION:

If using the vehicle for towing, the A/T fluid must be replaced as specified. Refer to [MA-6, "Introduction of Periodic Maintenance"](#).

1. Drive the vehicle to warm up the A/T fluid to approximately 80° C (176° F).
2. Stop the engine.
3. Remove the A/T fluid level gauge.
4. Drain the A/T fluid from the drain plug hole, then install the drain plug with a new gasket. Refill the transmission with new A/T fluid. Always refill with the same volume as the drained A/T fluid. Use the A/T fluid level gauge to check the A/T fluid level as shown. Add A/T fluid as necessary.

**Drain plug** : Refer to [TM-213, "Component"](#).

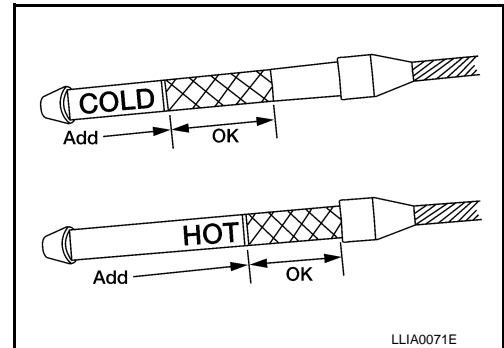

- To flush out the old A/T fluid from the transmission oil coolers, pour new A/T fluid into the A/T fluid charging pipe with the engine idling and at the same time drain the old A/T fluid from the auxiliary transmission oil cooler hose return line.
- When the color of the A/T fluid coming out of the auxiliary transmission oil cooler hose return line is about the same as the color of the new A/T fluid, flushing out the old A/T fluid is complete. The amount of new A/T fluid used for flushing should be 30% to 50% increase of the specified capacity.

**A/T fluid grade and capacity** : Refer to [MA-10, "Fluids and Lubricants"](#).

### CAUTION:

- If Genuine NISSAN Matic S ATF is not available, Genuine NISSAN Matic J ATF may also be used.
  - Using ATF fluid other than Genuine NISSAN Matic S ATF or Matic J ATF will cause deterioration in driveability and A/T durability, and may damage the A/T, which is not covered by the warranty.
  - When filling the transmission with A/T fluid, do not spill the A/T fluid on any heat generating parts such as the exhaust parts.
  - Do not reuse the drain plug gasket.
5. Install the A/T fluid level gauge and tighten the A/T fluid level gauge bolt to specification.

**A/T fluid level gauge bolt** : Refer to [TM-207, "Removal and Installation \(2WD\)"](#) or [TM-209, "Removal and Installation \(4WD\)"](#).

6. Drive the vehicle to warm up the A/T fluid to approximately 80° C (176° F).

# CHASSIS AND BODY MAINTENANCE

## < ON-VEHICLE MAINTENANCE >

7. Check the fluid level and condition. If the A/T fluid is still dirty, repeat steps 2 through 6.

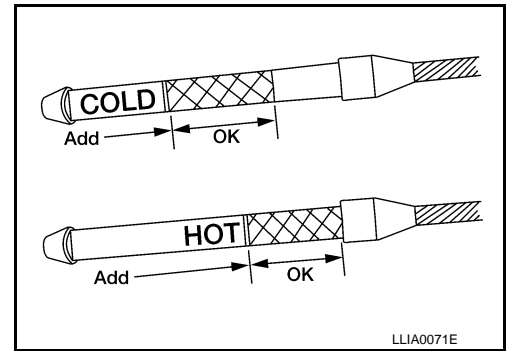

8. Install the A/T fluid level gauge in the A/T fluid charging pipe and install the A/T fluid level gauge bolt.
9. Tighten the A/T fluid level gauge bolt to specification.

**A/T fluid level gauge bolt** : Refer to [TM-207, "Removal and Installation \(2WD\)"](#) or [TM-209, "Removal and Installation \(4WD\)"](#).

## Changing Transfer Fluid

INFOID:000000005387364

### CAUTION:

If using the vehicle for towing, the transfer fluid must be replaced as specified. Refer to [MA-6, "Introduction of Periodic Maintenance"](#).

### DRAINING

1. Stop engine.
2. Remove the drain plug and gasket and drain the fluid.
3. Install the drain plug with a new gasket to the transfer. Tighten to the specified torque. Refer to [TM-213, "Component"](#).

### CAUTION:

Do not reuse gasket.

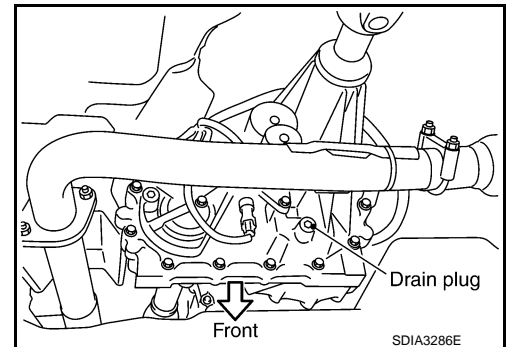

### FILLING

1. Remove the filler plug and gasket.
2. Fill the transfer with new fluid until the fluid level reaches the specified limit near the filler plug hole.

**Fluid grade and capacity** : Refer to [MA-10, "Fluids and Lubricants"](#).

### CAUTION:

Carefully fill fluid. (Fill up for approx. 3 minutes.)

3. Leave the vehicle for 3 minutes, and check fluid level again.
4. Install the filler plug with a new gasket to the transfer. Tighten to the specified torque. Refer to [TM-213, "Component"](#).

### CAUTION:

Do not reuse gasket.

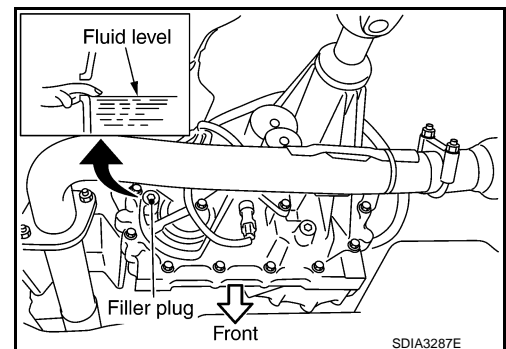

## Checking Transfer Fluid

INFOID:000000005387365

### CAUTION:

If using the vehicle for towing, the transfer fluid must be replaced as specified. Refer to [MA-6, "Introduction of Periodic Maintenance"](#).



# CHASSIS AND BODY MAINTENANCE

## < ON-VEHICLE MAINTENANCE >

### FLUID LEAKAGE AND FLUID LEVEL

1. Make sure that fluid is not leaking from the transfer assembly or around it.
2. Check fluid level from the filler plug hole as shown.

**CAUTION:**

**Do not start engine while checking fluid level.**

3. Install the filler plug with a new gasket to the transfer. Tighten to the specified torque. Refer to [MA-24, "Checking Transfer Fluid"](#).

**CAUTION:**

**Do not reuse gasket.**

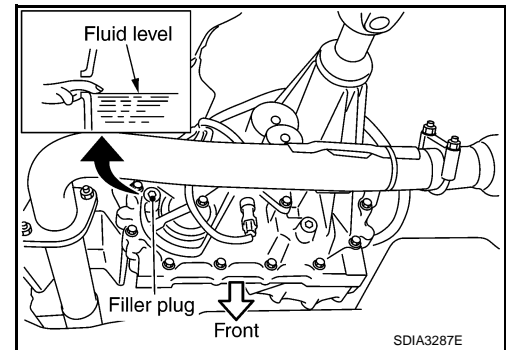

INFOID:000000005387366

### Checking Propeller Shaft

Check the front and rear propeller shafts for damage, dents, and cracks. Check the joints for looseness and any damage. Repair or replace as necessary.

### Changing Front Final Drive Oil

INFOID:000000005387367

#### DRAINING

1. Stop the engine.
2. Remove the drain plug from the front final drive assembly to drain the differential gear oil.
3. Install the drain plug with sealant applied on the threads to the front final drive assembly. Tighten to the specified torque. Refer to [DLN-169, "Disassembly and Assembly"](#).
  - Use High Performance Thread Sealant or equivalent. Refer to [GI-14, "Recommended Chemical Products and Sealants"](#).

#### FILLING

1. Remove the filler plug from the front final drive assembly.
2. Fill the front final drive assembly with new differential gear oil until the level reaches the specified level near the filler plug hole.

**Differential gear oil grade and capacity** : Refer to [MA-10, "Fluids and Lubricants"](#).

3. Install the filler plug with sealant applied on the threads to the front final drive assembly. Tighten to the specified torque. Refer to [DLN-169, "Disassembly and Assembly"](#).
  - Use High Performance Thread Sealant or equivalent. Refer to [GI-14, "Recommended Chemical Products and Sealants"](#).

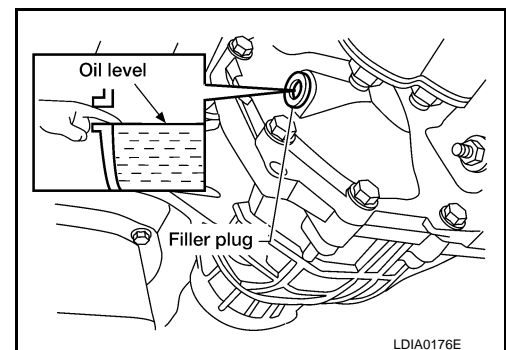

INFOID:000000005387368

### Checking Front Final Drive Oil

#### DIFFERENTIAL GEAR OIL LEAKAGE AND LEVEL

1. Make sure that differential gear oil is not leaking from the front final drive assembly or around it.
2. Check the differential gear oil level from the filler plug hole as shown.

**CAUTION:**

**Do not start engine while checking differential gear oil level.**

3. Install the filler plug with sealant applied on the threads to the front final drive assembly. Tighten to the specified torque. Refer to [DLN-169, "Disassembly and Assembly"](#).
  - Use High Performance Thread Sealant or equivalent. Refer to [GI-14, "Recommended Chemical Products and Sealants"](#).

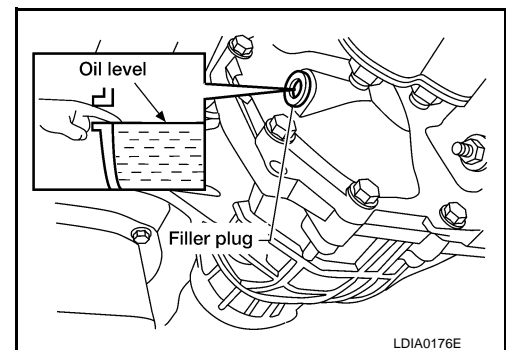

A  
B  
C  
D  
E  
F  
G  
H  
I  
J  
K  
L  
M  
N  
O

MA

# CHASSIS AND BODY MAINTENANCE

## < ON-VEHICLE MAINTENANCE >

### Changing Rear Final Drive Oil

INFOID:000000005387369

#### DRAINING

1. Stop engine.
2. Remove the drain plug from the rear final drive assembly to drain the differential gear oil.
3. Install the drain plug with sealant applied on the threads to the rear final drive assembly.
  - Use High Performance Thread Sealant or equivalent. Refer to [GI-14, "Recommended Chemical Products and Sealants"](#).

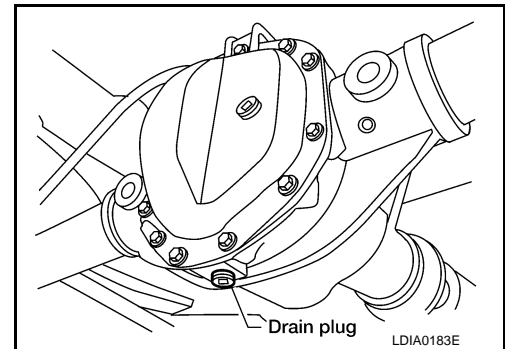

#### FILLING

1. Remove the filler plug from the rear final drive assembly.
2. Fill the rear final drive assembly with new differential gear oil until the level reaches the specified level near the filler plug hole.

**Differential gear oil grade and capacity** : Refer to [MA-10, "Fluids and Lubricants"](#).

3. Install the filler plug with sealant applied on the threads to the rear final drive assembly. Tighten to the specified torque. Refer to [DLN-197, "Disassembly and Assembly"](#) (without ELD) or [DLN-261, "Disassembly and Assembly"](#) (with ELD).
  - Use High Performance Thread Sealant or equivalent. Refer to [GI-14, "Recommended Chemical Products and Sealants"](#).

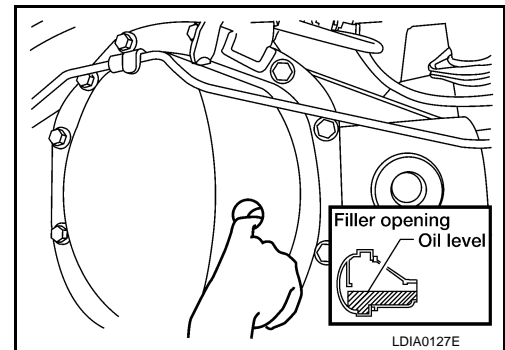

### Checking Rear Final Drive Oil

INFOID:000000005387370

#### DIFFERENTIAL GEAR OIL LEAKAGE AND LEVEL

1. Make sure that differential gear oil is not leaking from the rear final drive assembly or around it.
2. Check the differential gear oil level from the filler plug hole as shown.

**CAUTION:**

**Do not start engine while checking differential gear oil level.**

3. Install the filler plug with sealant applied on the threads to the rear final drive assembly. Tighten to the specified torque. Refer to [DLN-197, "Disassembly and Assembly"](#) (without ELD) or [DLN-261, "Disassembly and Assembly"](#) (with ELD).
  - Use High Performance Thread Sealant or equivalent. Refer to [GI-14, "Recommended Chemical Products and Sealants"](#).

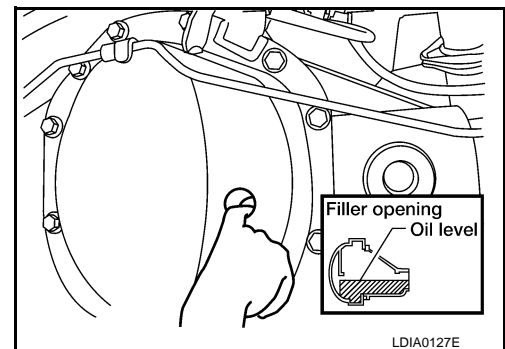

### Wheel and Tire Assembly

INFOID:000000005713743

#### BALANCING WHEELS (ADHESIVE WEIGHT TYPE)

##### Preparation Before Adjustment

Remove inner and outer balance weights from the road wheel using releasing agent, remove double-faced adhesive tape from the road wheel.

**CAUTION:**

- Be careful not scratch the road wheel during removal.
- After removing double-faced adhesive tape, wipe clean traces of releasing agent from the road wheel.

# CHASSIS AND BODY MAINTENANCE

## < ON-VEHICLE MAINTENANCE >

### Wheel Balance Adjustment

- If a balancer machine has an adhesive weight mode setting, select the adhesive weight mode setting and skip Step 2. below. If a balancer machine only has the clip-on (rim flange) weight mode setting, follow Step 2. to calculate the correct size adhesive weight.

1. Set road wheel on balancer machine using the center hole as a guide. Start the balancer machine.
2. For tire balance machines that only have a clip-on (rim flange) weight mode setting, follow this step to calculate the correct size adhesive weight to use. When inner and outer imbalance values are shown on the balancer machine indicator, multiply outer imbalance value by 5/3 (1.67) to determine balance weight that should be used. Select the outer balance weight with a value closest to the calculated value above and install in to the designated outer position of, or at the designated angle in relation to the road wheel.

- a. Indicated unbalance value  $\times 5/3 =$  balance weight to be installed

**Calculation example:**

$23 \text{ g (0.81 oz)} \times 5/3 (1.67) = 38.33 \text{ g (1.35 oz)} \Rightarrow 40 \text{ g (1.41 oz)}$   
balance weight (closer to calculated balance weight value)

**NOTE:**

Note that balance weight value must be closer to the calculated balance weight value.

**Example:**

$37.4 \Rightarrow 35 \text{ g (1.23 oz)}$

$37.5 \Rightarrow 40 \text{ g (1.41 oz)}$

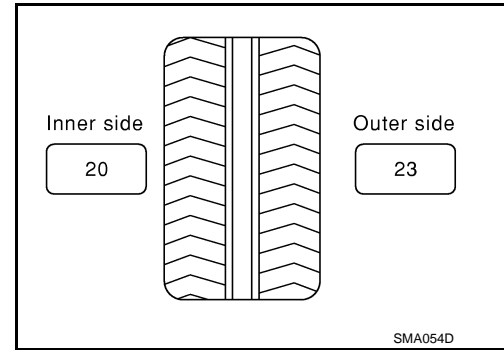

3. Install balance weight in the position shown.

**CAUTION:**

- Do not install the inner balance weight before installing the outer balance weight.
- Before installing the balance weight, be sure to clean the mating surface of the road wheel.
- When installing balance weight (1) to road wheel, set it into the grooved area (A) on the inner wall of the road wheel as shown so that the balance weight center (B) is aligned with the balancer machine indication position (angle) (C).

**CAUTION:**

- Always use genuine NISSAN adhesive balance weights.
- Balance weights are non-reusable; always replace with new ones.
- Do not install more than three sheets of balance weight.

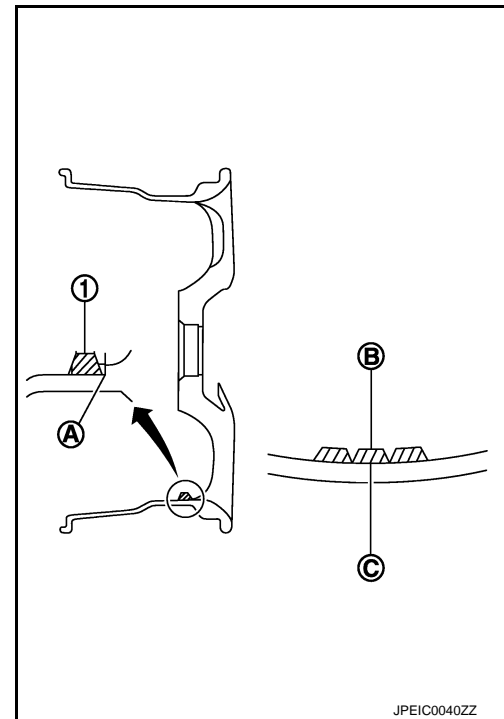

4. If calculated balance weight value exceeds 50 g (1.76 oz), install two balance weight sheets in line with each other as shown.

**CAUTION:**

**Do not install one balance weight sheet on top another.**

5. Start balancer machine again.
6. Install balance weight on inner side of road wheel in the balancer machine indication position (angle).

**CAUTION:**

**Do not install more than two balance weight.**

7. Start balancer machine. Make sure that inner and outer residual unbalance values are 5 g (0.17 oz) each or below.

8. If either residual unbalance value exceeds 5 g (0.17 oz), repeat installation procedures.

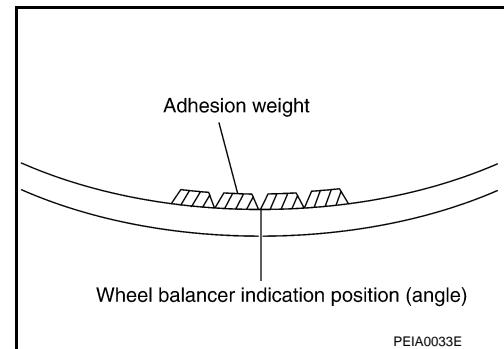

A  
B  
C  
D  
E  
F  
G  
H  
I  
J  
K  
L  
M  
N  
O

MA

# CHASSIS AND BODY MAINTENANCE

## < ON-VEHICLE MAINTENANCE >

Wheel balance	Dynamic (At flange)	Static (At flange)
Maximum allowable unbalance	Refer to <a href="#">WT-45, "Inspection"</a> .	

### TIRE ROTATION

- Follow the maintenance schedule for tire rotation service intervals. Refer to [MA-6, "Schedule 1"](#).
- When installing the wheel, tighten wheel nuts to the specified torque.

#### CAUTION:

- Do not include the T-type spare tire when rotating the tires.
- When installing wheels, tighten them diagonally by dividing the work two to three times in order to prevent the wheels from developing any distortion.
- Be careful not to tighten wheel nut at torque exceeding the criteria for preventing strain of disc rotor.
- Use NISSAN genuine wheel nuts for aluminum wheels.

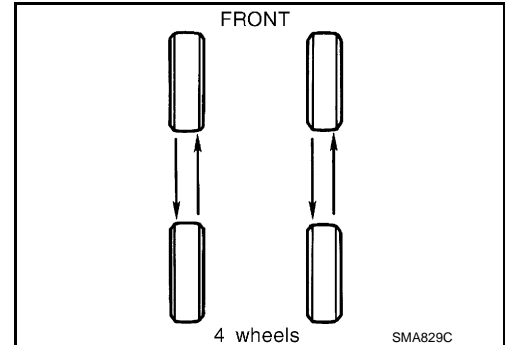

**Wheel nut tightening : 133 N-m (14 kg-m, 98 ft-lb) torque**

- Perform the ID registration, after tire rotation. Refer to [WT-6, "ID Registration Procedure"](#).

### Checking Brake Fluid Level and Leaks

INFOID:000000005713744

#### LEVEL CHECK

- Make sure the fluid level in reservoir tank is between MAX and MIN lines as shown.
- Visually check around reservoir tank for fluid leaks.
- If fluid level is excessively low, check brake system for leaks.
- If brake warning lamp remains illuminated after parking brake pedal is released, check brake system for fluid leaks.

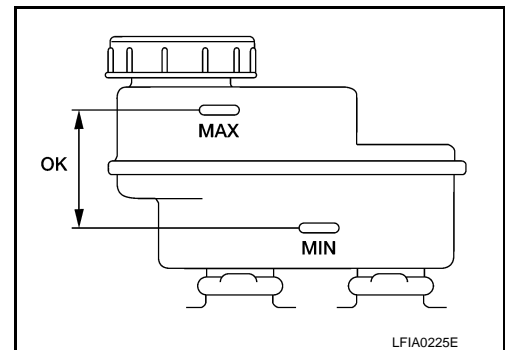

### Checking Brake Line and Cables

INFOID:000000005387374

- Check the brake lines and hoses for cracks, deterioration, and other damage. Replace any damaged parts.

#### CAUTION:

**If brake fluid leaks are visible around the brake line joints, retighten the joint, or replace damaged parts as necessary.**

- Check for brake fluid leaks by fully depressing brake pedal while engine is running.

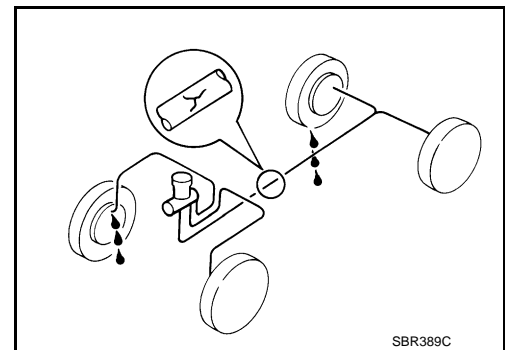

### Checking Disc Brake

INFOID:000000005387375

#### ROTOR

# CHASSIS AND BODY MAINTENANCE

## < ON-VEHICLE MAINTENANCE >

Check the rotor condition for wear or damage. Refer to [BR-6, "DISC ROTOR : Inspection"](#) (front disc rotor) , [BR-7, "DISC ROTOR : Inspection"](#) (rear disc rotor) .

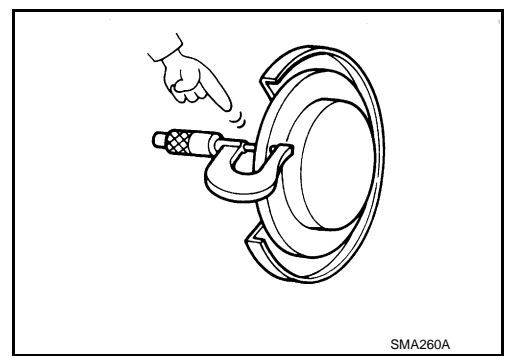

### CALIPER

Check the caliper for leaks, repair as necessary.

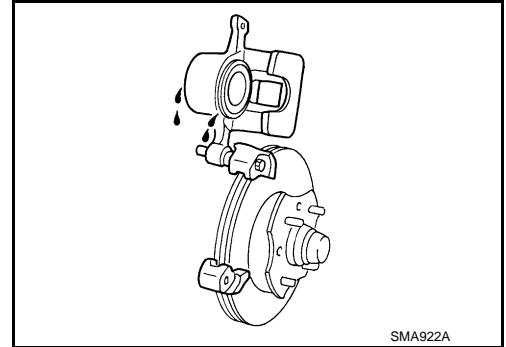

### PAD

Check the pads for wear or damage. Refer to [BR-6, "BRAKE PAD : Inspection"](#) (front disc pad) , [BR-7, "BRAKE PAD : Inspection"](#) (rear disc pad) .

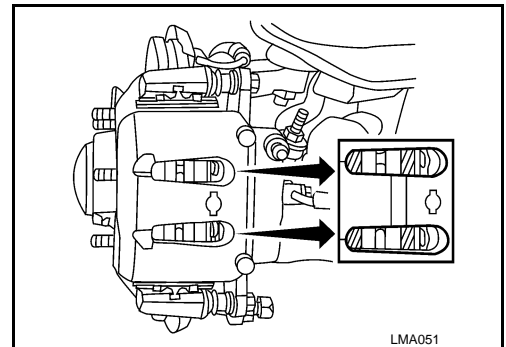

## Checking Steering Gear and Linkage

INFOID:000000005387376

### STEERING GEAR

- Check the steering gear housing for looseness, damage, and oil leakage as shown.
- Check the steering column connections for looseness.

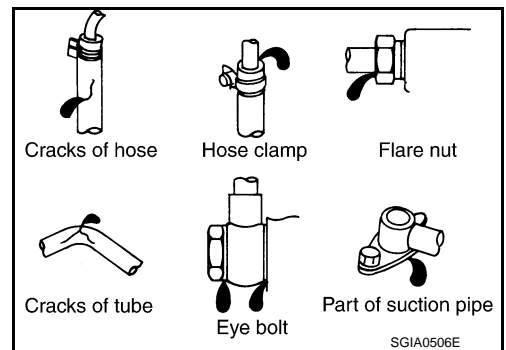

### STEERING LINKAGE

- Check the ball joint, dust cover and other component parts for looseness, wear, damage, and grease leakage.

## Checking Power Steering Fluid and Line

INFOID:000000005387377

### CHECKING FLUID LEVEL

A  
B  
C  
D  
E  
F  
G  
H  
I  
J  
K  
L  
M  
N  
O  
MA

# CHASSIS AND BODY MAINTENANCE

## < ON-VEHICLE MAINTENANCE >

- Check the power steering fluid level with the engine off.
- Check fluid level on reservoir. Use "HOT" range at fluid temperatures of 50° to 80°C (122° to 176°F). Use "COLD" range at fluid temperatures of 0° to 30°C (32° to 86°F).

### CAUTION:

- Do not overfill.
- Recommended fluid is Genuine NISSAN PSF or equivalent. Refer to [MA-10, "Fluids and Lubricants"](#) .

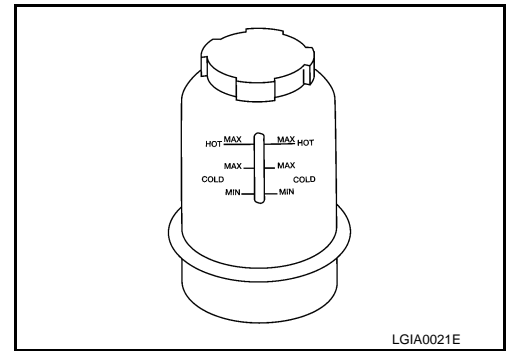

## CHECKING LINES

- Check lines for improper attachment, leaks, cracks, damage, loose connections, chafing, and deterioration.

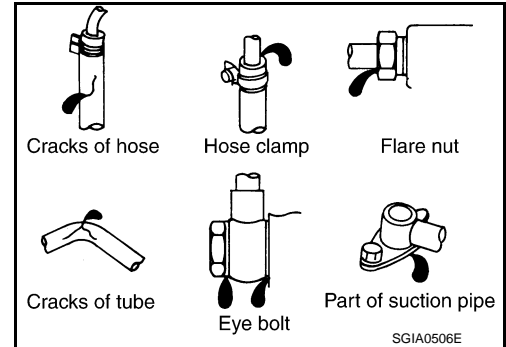

## Checking Axle and Suspension Parts

INFOID:000000005387378

### FRONT AND REAR AXLE AND SUSPENSION PARTS

Check front and rear axle and suspension parts for excessive play, cracks, wear or other damage.

- Shake each wheel to check for excessive play.
- Rotate each wheel to check for abnormal noise.

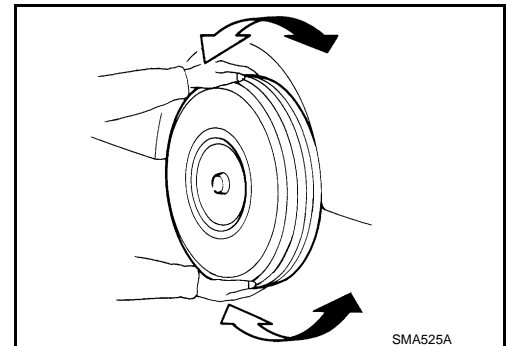

- Check the axle and suspension nuts and bolts for looseness.
- Check the strut and shock absorber for oil leakage or other damage.
- Check the suspension ball joints for grease leakage and ball joint dust cover for cracks or other damage.

### PROPELLER SHAFT

Inspect the propeller shaft tube for dents or cracks. If damaged, replace the propeller shaft assembly.

# CHASSIS AND BODY MAINTENANCE

< ON-VEHICLE MAINTENANCE >

## Lubricating Locks, Hinges and Hood Latches

INFOID:000000005387379

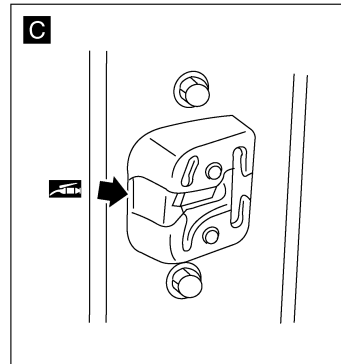
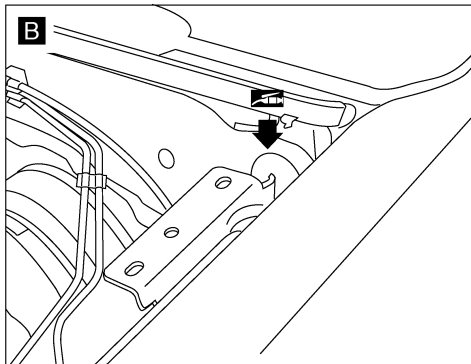
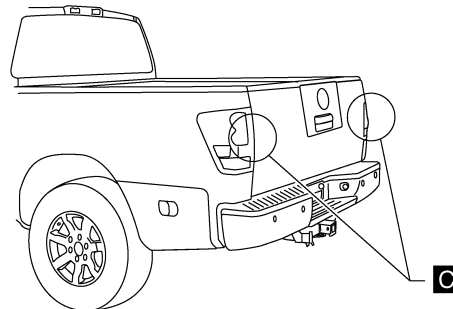
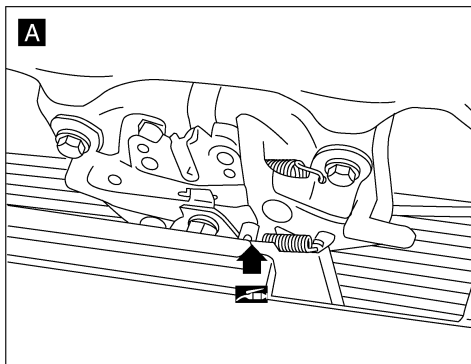
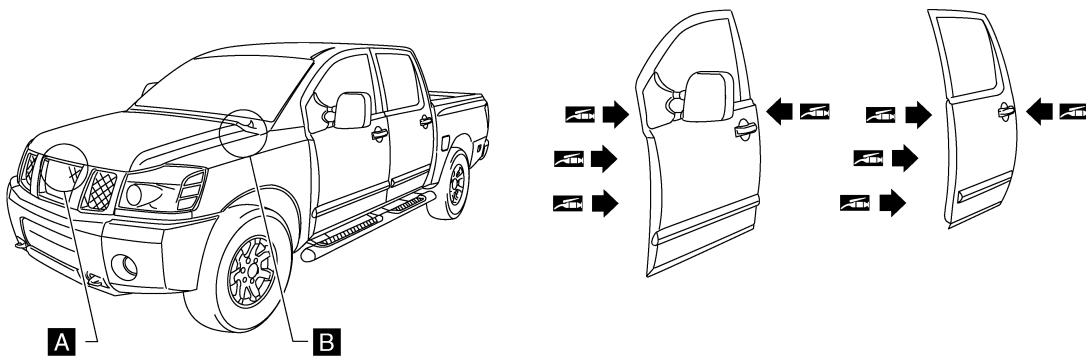

 : Multi-purpose grease

WLIA0019E

### NOTE:

Lubricate the locations shown with a suitable multi-purpose grease. Refer to [MA-10, "Fluids and Lubricants"](#)

## Checking Seat Belts, Buckles, Retractors, Anchors and Adjusters

INFOID:000000005387380

Check the seat belt buckles, webbing, retractors, anchors and adjusters. Replace any seat belt assembly as necessary. Refer to [SB-10, "Seat Belt Inspection"](#).

- Check the seat belt anchors for loose mounting bolts, damage, or excessive wear.
- Check the seat belt webbing for any damage, cuts, fraying, or excessive wear.
- Check the retractor for smooth operation.
- Check the function of the buckles by inserting the seat belt tongue and checking for proper engagement of the buckle and press the button on the buckle to check for proper release of the seat belt tongue.

### WARNING:

## CHASSIS AND BODY MAINTENANCE

### < ON-VEHICLE MAINTENANCE >

---

- After any collision, inspect all seat belt assemblies, including retractors and other attached components, such as the guide rail set. NISSAN recommends replacing all seat belt assemblies in use during a collision, unless they are not damaged and are inspected to confirm they are operating properly after a minor collision.  
Also inspect all seat belt assemblies that are not in use during a collision, and replace any components if damaged or not operating properly. The seat belt pre-tensioner should be replaced even if the seat belts are not in use during a frontal collision where the driver and passenger air bags have been deployed.
- If any component of the seat belt assembly is suspected of being damaged or not operating properly, do not repair the component. Replace the components as an assembly.
- If the seat belt webbing is cut, frayed, or damaged then replace the seat belt assembly.
- Never lubricate the seat belt buckle or tongue.
- When replacing any seat belt assembly always use a Genuine NISSAN seat belt assembly.