A

SECTION ACC

ACC

C

ACC

ACCELERATOR CONTROL SYSTEM

CONTENTS

PRECAUTION 2	ACCELERATOR CONTROL SYSTEM 3	F
PRECAUTIONS 2	Removal and Installation 3	
Precaution for Supplemental Restraint System (SRS) "AIR BAG" and "SEAT BELT PRE-TEN- SIONER" 2	SERVICE DATA AND SPECIFICATIONS (SDS) 7	G
REMOVAL AND INSTALLATION 3	SERVICE DATA AND SPECIFICATIONS (SDS) 7	H
	Accelerator Control 7	I

PRECAUTIONS

< PRECAUTION >

PRECAUTION

PRECAUTIONS

Precaution for Supplemental Restraint System (SRS) "AIR BAG" and "SEAT BELT PRE-TENSIONER"

INFOID:000000006161304

The Supplemental Restraint System such as "AIR BAG" and "SEAT BELT PRE-TENSIONER", used along with a front seat belt, helps to reduce the risk or severity of injury to the driver and front passenger for certain types of collision. This system includes seat belt switch inputs and dual stage front air bag modules. The SRS system uses the seat belt switches to determine the front air bag deployment, and may only deploy one front air bag, depending on the severity of a collision and whether the front occupants are belted or unbelted. Information necessary to service the system safely is included in the SR and SB section of this Service Manual.

WARNING:

- To avoid rendering the SRS inoperative, which could increase the risk of personal injury or death in the event of a collision which would result in air bag inflation, all maintenance must be performed by an authorized NISSAN/INFINITI dealer.
- Improper maintenance, including incorrect removal and installation of the SRS, can lead to personal injury caused by unintentional activation of the system. For removal of Spiral Cable and Air Bag Module, see the SR section.
- Do not use electrical test equipment on any circuit related to the SRS unless instructed to in this Service Manual. SRS wiring harnesses can be identified by yellow and/or orange harnesses or harness connectors.

PRECAUTIONS WHEN USING POWER TOOLS (AIR OR ELECTRIC) AND HAMMERS

WARNING:

- When working near the Airbag Diagnosis Sensor Unit or other Airbag System sensors with the Ignition ON or engine running, DO NOT use air or electric power tools or strike near the sensor(s) with a hammer. Heavy vibration could activate the sensor(s) and deploy the air bag(s), possibly causing serious injury.
- When using air or electric power tools or hammers, always switch the Ignition OFF, disconnect the battery, and wait at least 3 minutes before performing any service.

ACCELERATOR CONTROL SYSTEM

< REMOVAL AND INSTALLATION >

REMOVAL AND INSTALLATION

ACCELERATOR CONTROL SYSTEM

Removal and Installation

INFOID:000000006161305

A
ACC

ADJUSTABLE ACCELERATOR PEDAL ASSEMBLY

Adjustable Accelerator Pedal

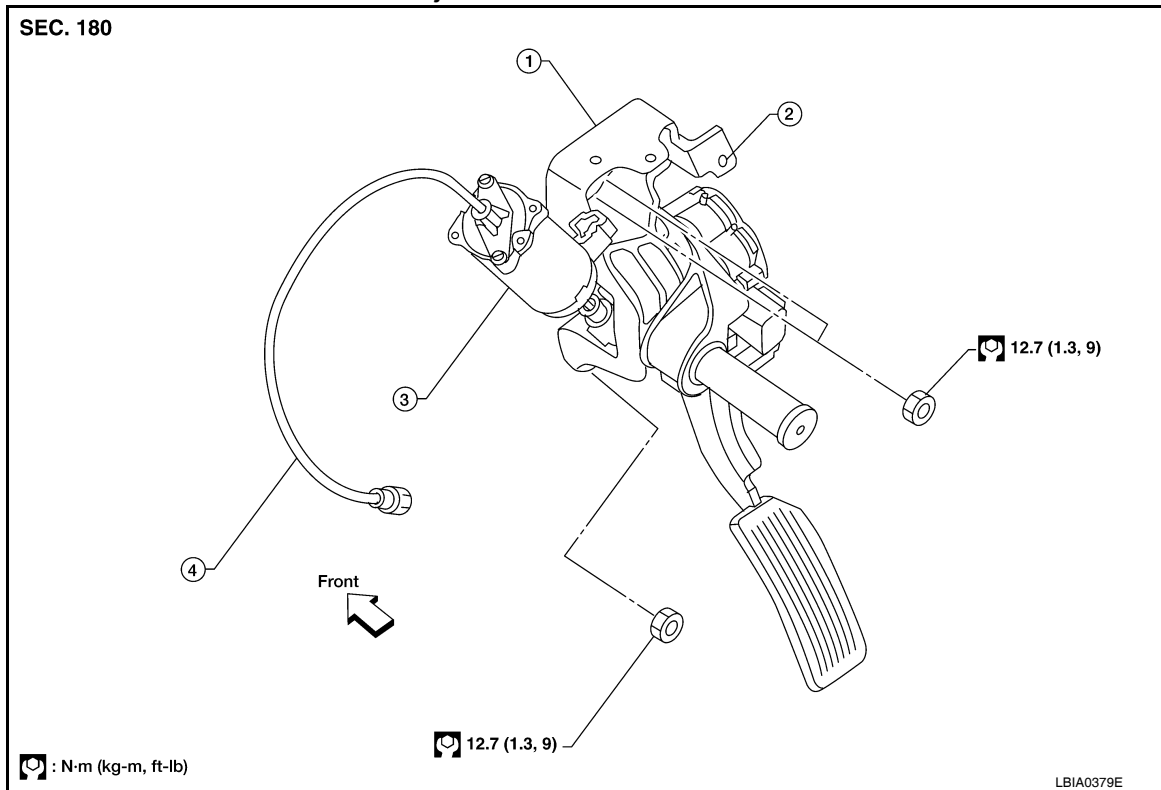

1. Adjustable accelerator pedal assembly
2. Adjustable accelerator pedal bracket (part of the accelerator pedal assembly)
3. Adjustable pedal electric motor (part of the accelerator pedal assembly)
4. Adjustable brake pedal cable (part of the accelerator pedal assembly)

CAUTION:

- Do not disassemble the accelerator pedal adjusting mechanism.
- Before removal and installation, the accelerator and brake pedals must be in the front most position. This is to align the base position of the accelerator and brake pedals.
- Do not disassemble the accelerator pedal assembly.
- Do not remove the accelerator pedal position sensor from the accelerator pedal bracket.
- Avoid damage from dropping the accelerator pedal assembly during handling.
- Keep the accelerator pedal assembly away from water.

Removal

1. Move the accelerator and brake pedals to the front most position.
2. Turn the ignition switch OFF and disconnect the negative battery terminal.
3. Disconnect the adjustable brake pedal cable from the adjustable brake pedal.
 - Unlock, then pull the adjustable brake pedal cable to disconnect it from the adjustable brake pedal.

C
D
E
F
G
H
I
J
K
L
M
N
O
P

ACCELERATOR CONTROL SYSTEM

< REMOVAL AND INSTALLATION >

4. Disconnect the adjustable pedal electric motor electrical connector.
5. Disconnect the adjustable pedal electric motor memory electrical connector, if equipped.
6. Disconnect the accelerator position sensor electrical connector.
7. Remove the two upper and one lower accelerator pedal nuts.
8. Remove the adjustable accelerator pedal assembly.

CAUTION:

- Do not disassemble the accelerator pedal assembly.
- Do not remove the accelerator pedal position sensor from the accelerator pedal bracket.
- Do not disassemble the accelerator pedal adjusting mechanism.
- Avoid damage from dropping the accelerator pedal assembly during handling.
- Keep the accelerator pedal assembly away from water.

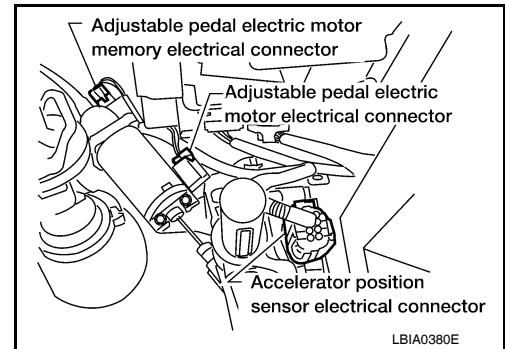

Installation

Installation is in the reverse order of removal.

Inspection After Installation

- Check that the accelerator pedal moves smoothly within the specified ranges.

Adjustable accelerator pedal – total pedal applied stroke : Refer to [ACC-7, "Accelerator Control"](#).

Adjustable accelerator pedal – total pedal height : Refer to [ACC-7, "Accelerator Control"](#).

• **WARNING:**

Depress and release the accelerator pedal to check that it returns quickly and smoothly to the original released position.

Perform an electrical inspection of the accelerator pedal position sensor. Refer to [EC-119](#).

CAUTION:

When the harness connector of the accelerator pedal position sensor is disconnected, perform "Accelerator Pedal Released Position Learning". Refer to [EC-119, "Accelerator Pedal Released Position Learning"](#).

NON-ADJUSTABLE ACCELERATOR PEDAL ASSEMBLY

ACCELERATOR CONTROL SYSTEM

< REMOVAL AND INSTALLATION >

Non-Adjustable Accelerator Pedal

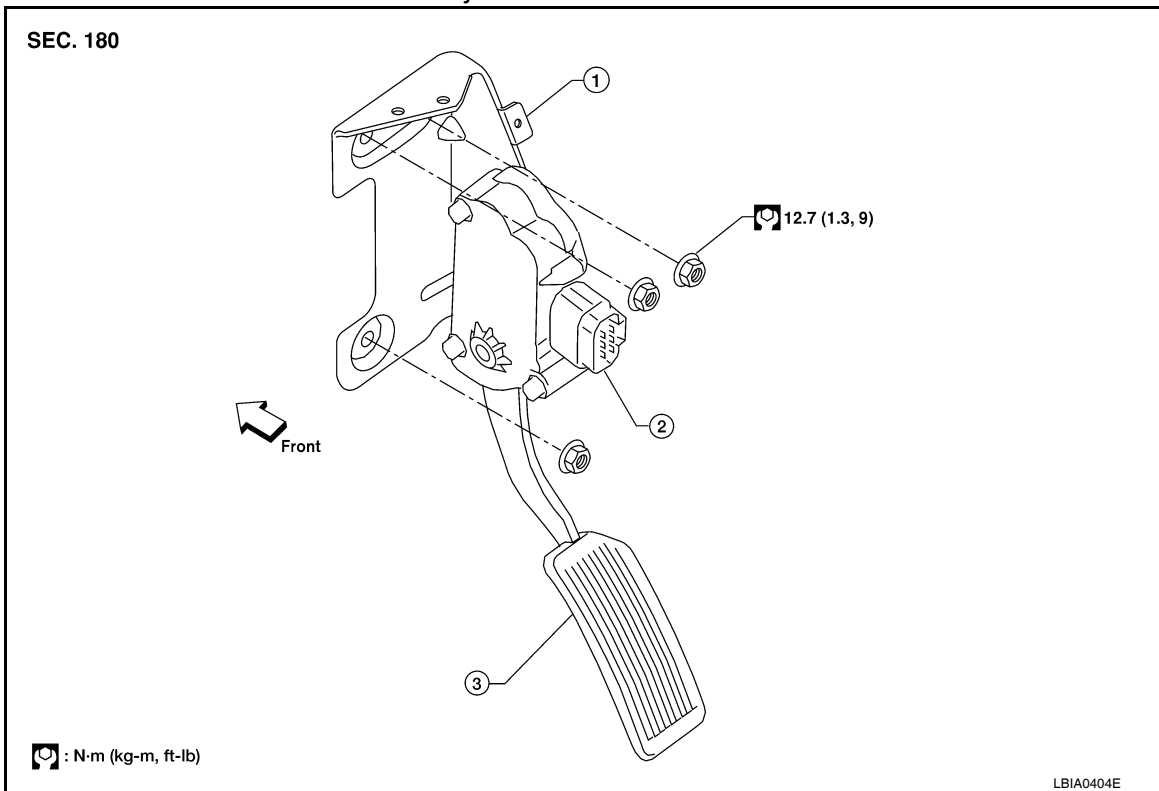

1. Non-adjustable accelerator pedal A/T cable attachment bracket (part of the accelerator pedal assembly)
2. Non-adjustable accelerator pedal position sensor (part of the accelerator pedal assembly)
3. Non-adjustable accelerator pedal assembly

CAUTION:

- Do not disassemble the accelerator pedal assembly.
- Do not remove the accelerator pedal position sensor from the accelerator pedal bracket.
- Avoid damage from dropping the accelerator pedal assembly during handling.
- Keep the accelerator pedal assembly away from water.

Removal

1. Turn the ignition switch OFF and disconnect the negative battery terminal.
2. Disconnect the accelerator position sensor electrical connector.
3. Remove the two upper and one lower accelerator pedal nuts.
4. Remove the adjustable accelerator pedal assembly.

CAUTION:

- Do not disassemble the accelerator pedal assembly.
- Do not remove the accelerator pedal position sensor from the accelerator pedal bracket.
- Avoid damage from dropping the accelerator pedal assembly during handling.
- Keep the accelerator pedal assembly away from water.

Installation

Installation is in the reverse order of removal.

Inspection After Installation

- Check that the accelerator pedal moves smoothly within the specified range.

Non-adjustable accelerator pedal – total pedal applied stroke : Refer to [ACC-7, "Accelerator Control"](#).

Non-adjustable accelerator pedal – total pedal height : Refer to [ACC-7, "Accelerator Control"](#).

- **WARNING:**

ACCELERATOR CONTROL SYSTEM

< REMOVAL AND INSTALLATION >

Depress and release the accelerator pedal to check that it returns quickly and smoothly to the original released position.

Perform an electrical inspection of the accelerator pedal position sensor. Refer to [EC-119](#).

CAUTION:

When the harness connector of the accelerator pedal position sensor is disconnected, perform "Accelerator Pedal Released Position Learning". Refer to [EC-119, "Accelerator Pedal Released Position Learning"](#).

SERVICE DATA AND SPECIFICATIONS (SDS)

< SERVICE DATA AND SPECIFICATIONS (SDS)

SERVICE DATA AND SPECIFICATIONS (SDS)

SERVICE DATA AND SPECIFICATIONS (SDS)

Accelerator Control

INFOID:000000006161306

A

ACC

ACCELERATOR PEDAL STROKE AND TRAVEL

Unit: mm (in)

Non-adjustable accelerator pedal - total pedal applied stroke	48 (1.89)
Non-adjustable accelerator pedal - total pedal height	170.4 (6.71)
Adjustable accelerator pedal - total pedal applied stroke	48.3 (1.90)
Adjustable accelerator pedal - total pedal height	137.3 ±10 (5.41 ±0.39)

C

D

E

F

G

H

I

J

K

L

M

N

O

P