

SECTION **BRM**
BODY REPAIR

A
B
C
D
E
F
G
H
I
J
BRM
L
M
N
O
P

CONTENTS

PRECAUTION	2	CORROSION PROTECTION	16
PRECAUTIONS	2	Body Sealing	16
Precaution for Supplemental Restraint System (SRS) "AIR BAG" and "SEAT BELT PRE-TEN- SIONER"	2	Corrosion Protection	18
FEATURES OF NEW MODEL	3	BODY CONSTRUCTION	22
BODY EXTERIOR PAINT COLOR	3	Body Construction	22
Body Exterior Paint Color	3	Body Mounting, King Cab	24
HANDLING PRECAUTIONS	4	Body Mounting, Crew Cab	25
Handling Precaution for Plastics	4	Rear Body	25
UNIT REMOVAL AND INSTALLATION	7	Foam Repair	27
BODY COMPONENT PARTS	7	BODY ALIGNMENT	28
Body Component Parts	7	Body Alignment	28
		REPAIRING HIGH STRENGTH STEEL	49
		Precaution in Repairing High Strength Steel	49
		REPLACEMENT OPERATIONS	52
		Replacement Operation	52

PRECAUTIONS

< PRECAUTION >

PRECAUTION

PRECAUTIONS

Precaution for Supplemental Restraint System (SRS) "AIR BAG" and "SEAT BELT PRE-TENSIONER"

INFOID:000000006158461

The Supplemental Restraint System such as "AIR BAG" and "SEAT BELT PRE-TENSIONER", used along with a front seat belt, helps to reduce the risk or severity of injury to the driver and front passenger for certain types of collision. This system includes seat belt switch inputs and dual stage front air bag modules. The SRS system uses the seat belt switches to determine the front air bag deployment, and may only deploy one front air bag, depending on the severity of a collision and whether the front occupants are belted or unbelted. Information necessary to service the system safely is included in the SR and SB section of this Service Manual.

WARNING:

- To avoid rendering the SRS inoperative, which could increase the risk of personal injury or death in the event of a collision which would result in air bag inflation, all maintenance must be performed by an authorized NISSAN/INFINITI dealer.
- Improper maintenance, including incorrect removal and installation of the SRS, can lead to personal injury caused by unintentional activation of the system. For removal of Spiral Cable and Air Bag Module, see the SR section.
- Do not use electrical test equipment on any circuit related to the SRS unless instructed to in this Service Manual. SRS wiring harnesses can be identified by yellow and/or orange harnesses or harness connectors.

PRECAUTIONS WHEN USING POWER TOOLS (AIR OR ELECTRIC) AND HAMMERS

WARNING:

- When working near the Airbag Diagnosis Sensor Unit or other Airbag System sensors with the Ignition ON or engine running, DO NOT use air or electric power tools or strike near the sensor(s) with a hammer. Heavy vibration could activate the sensor(s) and deploy the air bag(s), possibly causing serious injury.
- When using air or electric power tools or hammers, always switch the Ignition OFF, disconnect the battery, and wait at least 3 minutes before performing any service.

BODY EXTERIOR PAINT COLOR

< FEATURES OF NEW MODEL >

FEATURES OF NEW MODEL

BODY EXTERIOR PAINT COLOR

Body Exterior Paint Color

INFOID:000000006158462

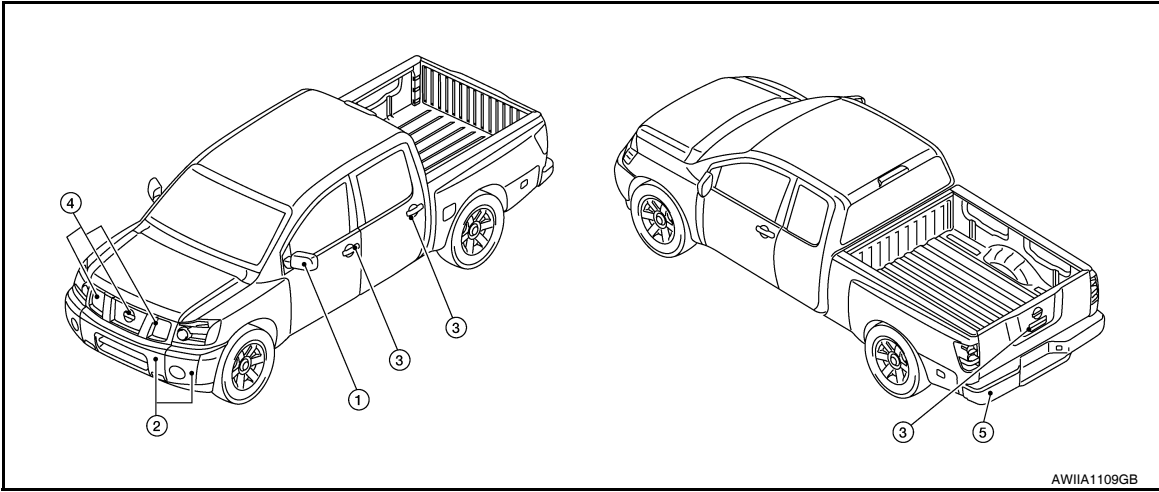

Component			Color code	A20	RAB	B30	G10	K11	K12	Q10	
			Description	Red Alert	Navy Blue	Blue Steel	Galaxy Black	Smoke	Radiant Silver	Blizzard	
			Paint type	M	M	M	2P	M	M	2S	
			Clear coat	t	t	t	t	t	t	t	
1	Outside mirror	XE, PRO-4X, SE	Black	KH3	KH3	KH3	KH3	KH3	KH3	KH3	
		LE and SE (Opt.)	Chrome	Cr	Cr	Cr	Cr	Cr	Cr	Cr	
2	Front bumper	XE, PRO-4X	Body color	A20	RAB	B30	G10	K11	K12	Q10	
		SE and LE	End caps	Body color	A20	RAB	B30	G10	K11	K12	Q10
			Center	Chrome	Cr	Cr	Cr	Cr	Cr	Cr	Cr
3	Outside handles	XE, SE, PRO-4X	Black	KH3	KH3	KH3	KH3	KH3	KH3	KH3	
		SE and LE	Chrome	Cr	Cr	Cr	Cr	Cr	Cr	Cr	
4	Radiator grille	XE, PRO-4X	Center	Body color	A20	RAB	B30	G10	K11	K12	Q10
				Chrome	Cr	Cr	Cr	Cr	Cr	Cr	Cr
		SE and LE	Grid	Black	KH3	KH3	KH3	KH3	KH3	KH3	KH3
5	Rear Bumper	XE, PRO-4X	Body color	A20	RAB	B30	G10	K11	K12	Q10	
		SE and LE	Chrome	Cr	Cr	Cr	Cr	Cr	Cr	Cr	

M: Metallic; 2S: 2-Coat Solid, 2P: 2-Coat Pearl; 3P: 3-Coat Pearl; t: Diamond Coat Clear

A
B
C
D
E
F
G
H
I
J
K
L
M
N
O
P

BRM

HANDLING PRECAUTIONS

< FEATURES OF NEW MODEL >

HANDLING PRECAUTIONS

Handling Precaution for Plastics

INFOID:000000006158463

Abbreviation	Material name	Heatresisting temperature °C (°F)	Resistance to gasoline and solvents	Other cautions
PE	Polyethylene	60 (140)	Gasoline and most solvents are harmless if applied for a very short time (wipe up quickly).	Flammable
PVC	Polyvinyl Chloride	80 (176)	Same as above.	Poison gas is emitted when burned.
EPM/EPDM	Ethylene Propylene (Diene) rubber	80 (176)	Same as above.	Flammable
TPO/TPR	Thermoplastic Olefine/ Thermoplastic Rubber	80 (176)	Same as above.	Flammable
PP	Polypropylene	90 (194)	Same as above.	Flammable, avoid battery acid.
UP	Polyester thermoset	90 (194)	Same as above.	Flammable
PS	Polystyrene	80 (176)	Avoid solvents.	Flammable
ABS	Acrylonitrile Butadiene Styrene resin	80 (176)	Avoid gasoline and solvents.	
AES	Acrylonitrile Ethylene Styrene	80 (176)	Same as above.	
PMMA	Polymethyl Methacrylate	85 (185)	Same as above.	
AAS	Acrylonitrile Acrylic Styrene	85 (185)	Same as above.	
AS	Acrylonitrile Styrene	85 (185)	Same as above.	
EVA	Polyvinyl Ethyl Acetate	90 (194)	Same as above.	
ASA	Acrylonitrile Styrene Acrylate	100 (222)	Same as above.	Flammable
PPO/PPE	Polyphenylene Oxide/ Polyphenylene Ether	110 (230)	Same as above.	
PC	Polycarbonate	120 (248)	Same as above.	
PAR	Polyacrylate	180 (356)	Same as above.	
L-LDPE	Linear Low Density PE	45 (100)	Gasoline and most solvents are harmless.	Flammable
PUR	Polyurethane	90 (194)	Same as above.	
TPU	Thermoplastic Urethane	110 (230)	Same as above.	
PPC	Polypropylene Composite	115 (239)	Same as above.	Flammable
POM	Polyacetal	120 (248)	Same as above.	Avoid battery acid.
PBT+PC	Polybutylene Terephthalate+Polycarbonate	120 (248)	Same as above.	Flammable
PA	Polyamide (Nylon)	140 (284)	Same as above.	Avoid immersing in water.
PBT	Polybutylene Terephthalate	140 (284)	Same as above.	
FRP	Fiber Reinforced Plastics	170 (338)	Same as above.	Avoid battery acid.
PET	Polyethylene Terephthalate	180 (356)	Same as above.	
PEI	Polyetherimide	200 (392)	Same as above.	

1. When repairing and painting a portion of the body adjacent to plastic parts, consider their characteristics (influence of heat and solvent) and remove them if necessary or take suitable measures to protect them.
2. Plastic parts should be repaired and painted using methods suiting the materials' characteristics.

HANDLING PRECAUTIONS

< FEATURES OF NEW MODEL >

LOCATION OF PLASTIC PARTS

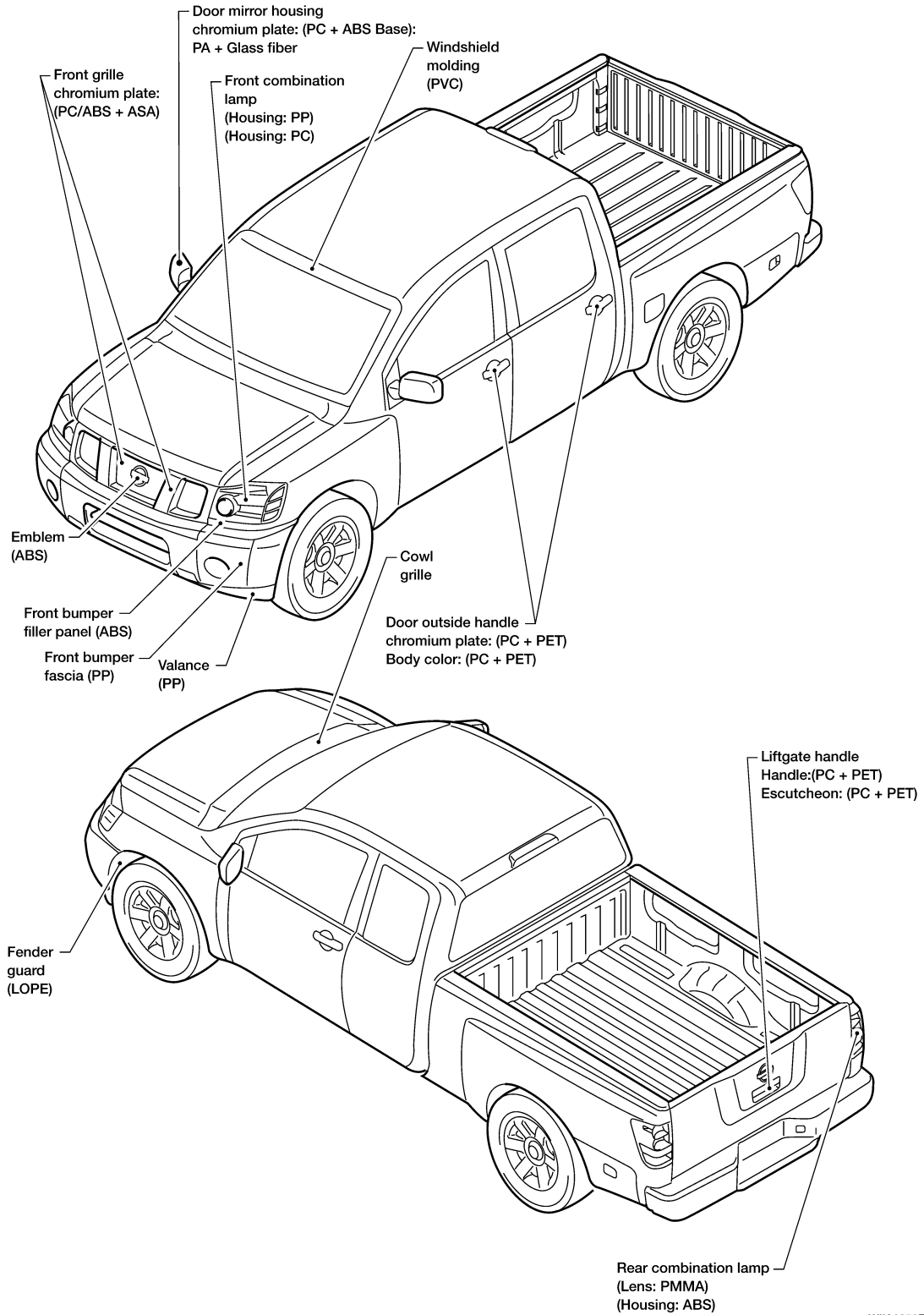

A
B
C
D
E
F
G
H
I
J
BRM
L
M
N
O
P

HANDLING PRECAUTIONS

< FEATURES OF NEW MODEL >

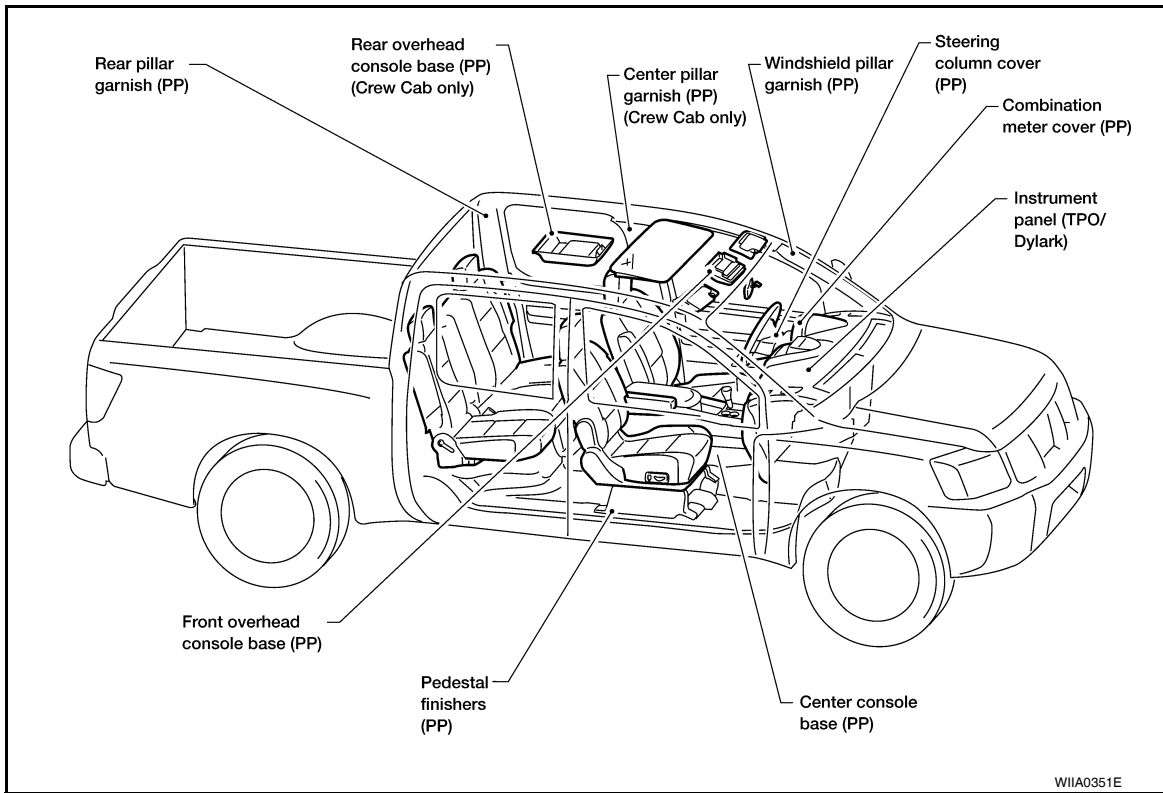

BODY COMPONENT PARTS

< UNIT REMOVAL AND INSTALLATION >



UNIT REMOVAL AND INSTALLATION

BODY COMPONENT PARTS

Body Component Parts

INFOID:000000006158464

UNDERBODY COMPONENT PARTS

-  : Indicates both-side anti-corrosive precoated steel portions
-  : Indicates high strength steel (HSS) portions
-  : Indicates both-side anti-corrosive precoated steel and (HSS) portions

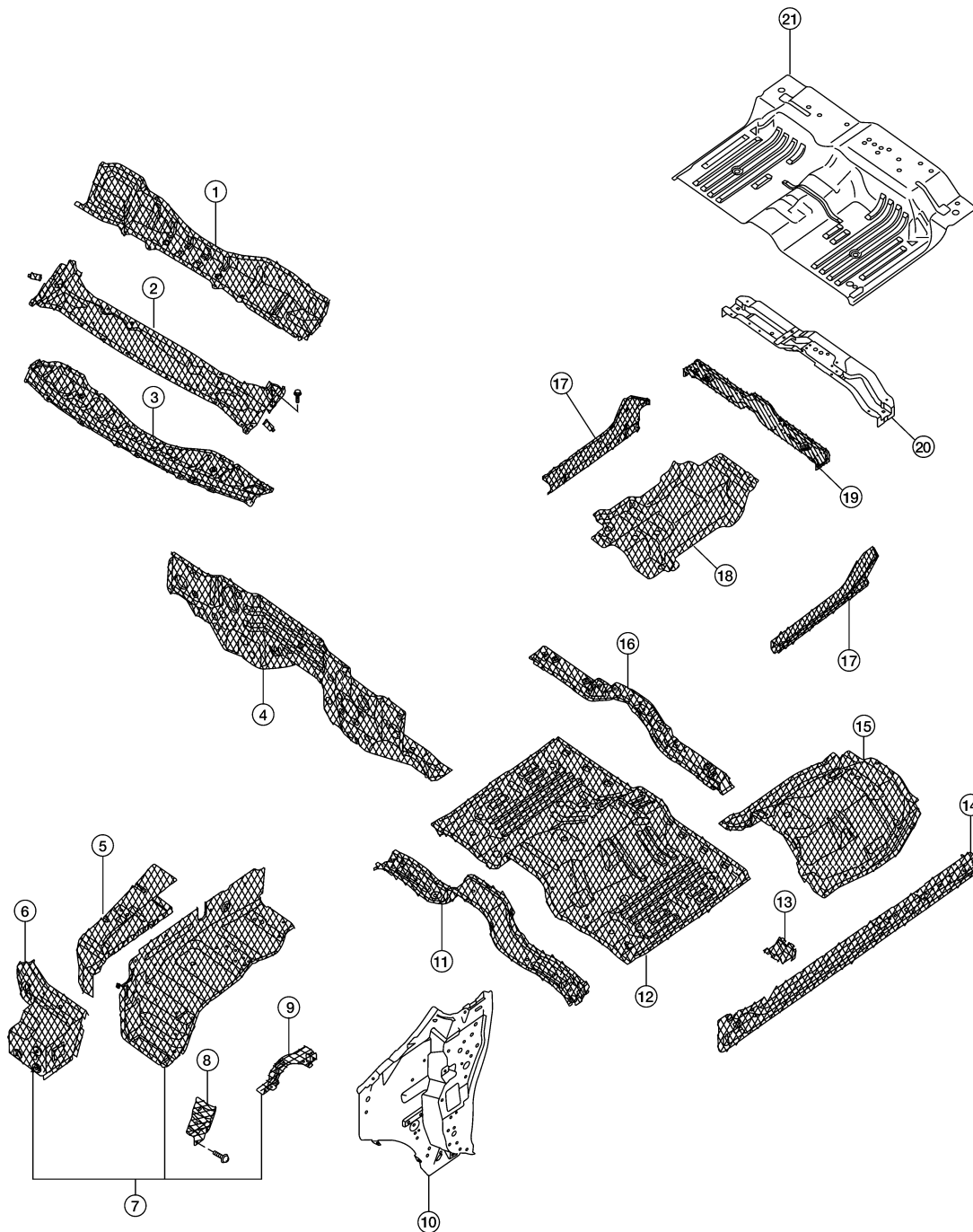

A
B
C
D
E
F
G
H
I
J
L
M
N
O
P

BRM

BODY COMPONENT PARTS

< UNIT REMOVAL AND INSTALLATION >



1. Upper dash assembly
2. Cowl top extension
3. Cowl top
4. Lower dash
5. Hoodledge reinforcement (RH & LH)
6. Battery mounting reinforcement (RH)
1st body mounting bracket (LH)
7. Hoodledge assembly (RH & LH)
8. Hoodledge front reinforcement (RH & LH)
9. Harness bracket (RH)
10. Dash side (RH & LH)
11. 2nd crossmember assembly
12. Front floor
13. 2nd crossmember extension (RH & LH)
14. Inner sill (RH & LH)
15. Front floor reinforcement
16. Front seat mounting crossmember
17. Inner sill extension (RH & LH)
18. Rear floor reinforcement assembly
19. 4th crossmember
20. Rear seat crossmember
21. Front floor rear

BODY COMPONENT PARTS

BODY COMPONENT PARTS

< UNIT REMOVAL AND INSTALLATION >

KING CAB

-  : Indicates both-side anti-corrosive pre-coated steel portions
-  : Indicates high strength steel (HSS) portions
-  : Indicates both-side anti-corrosive pre-coated steel and (HSS) portions

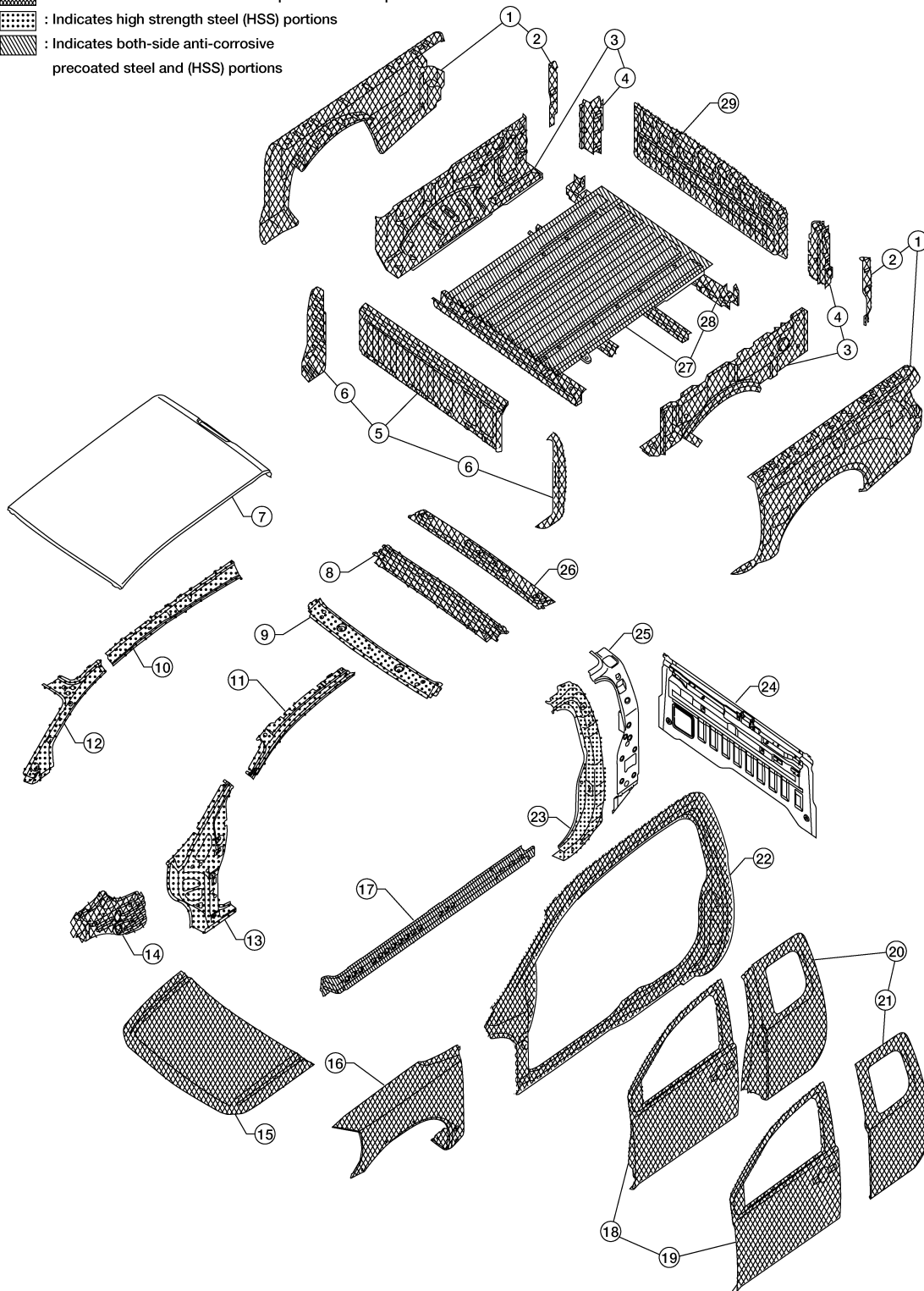

1. Side panel assembly (RH & LH)
2. Inner rear strut assembly (RH & LH)
3. Inner side panel assembly (RH & LH)
4. Rear strut assembly (RH & LH)
5. Header panel assembly
6. Front outer strut assembly (RH & LH)

A
B
C
D
E
F
G
H
I
J
K
L
M
N
O
P

BRM

BODY COMPONENT PARTS



< UNIT REMOVAL AND INSTALLATION >

7. Roof
8. No. 1 roof bow
9. Front roof rail
10. Inner roof side rail (RH & LH)
11. Upper front pillar reinforcement (RH & LH)
12. Inner upper front pillar (RH & LH)
13. Front pillar brace (RH & LH)
14. Rear hoodledge reinforcement (RH & LH)
15. Hood
16. Front fender (RH & LH)
17. Outer sill reinforcement (RH & LH)
18. Front door assembly (RH & LH)
19. Front door outer panel (RH & LH)
20. Rear door assembly (RH & LH)
21. Rear door outer panel (RH & LH)
22. Body side outer (RH & LH)
23. Outer lock pillar reinforcement (RH & LH)
24. Back panel assembly
25. Inner lock pillar (RH & LH)
26. Rear roof rail
27. Rear body floor assembly
28. Floor tail bolster assembly
29. Rear gate

BODY COMPONENT PARTS

< UNIT REMOVAL AND INSTALLATION >

CREW CAB

-  : Indicates both-side anti-corrosive precoated steel portions
-  : Indicates high strength steel (HSS) portions
-  : Indicates both-side anti-corrosive precoated steel and (HSS) portions

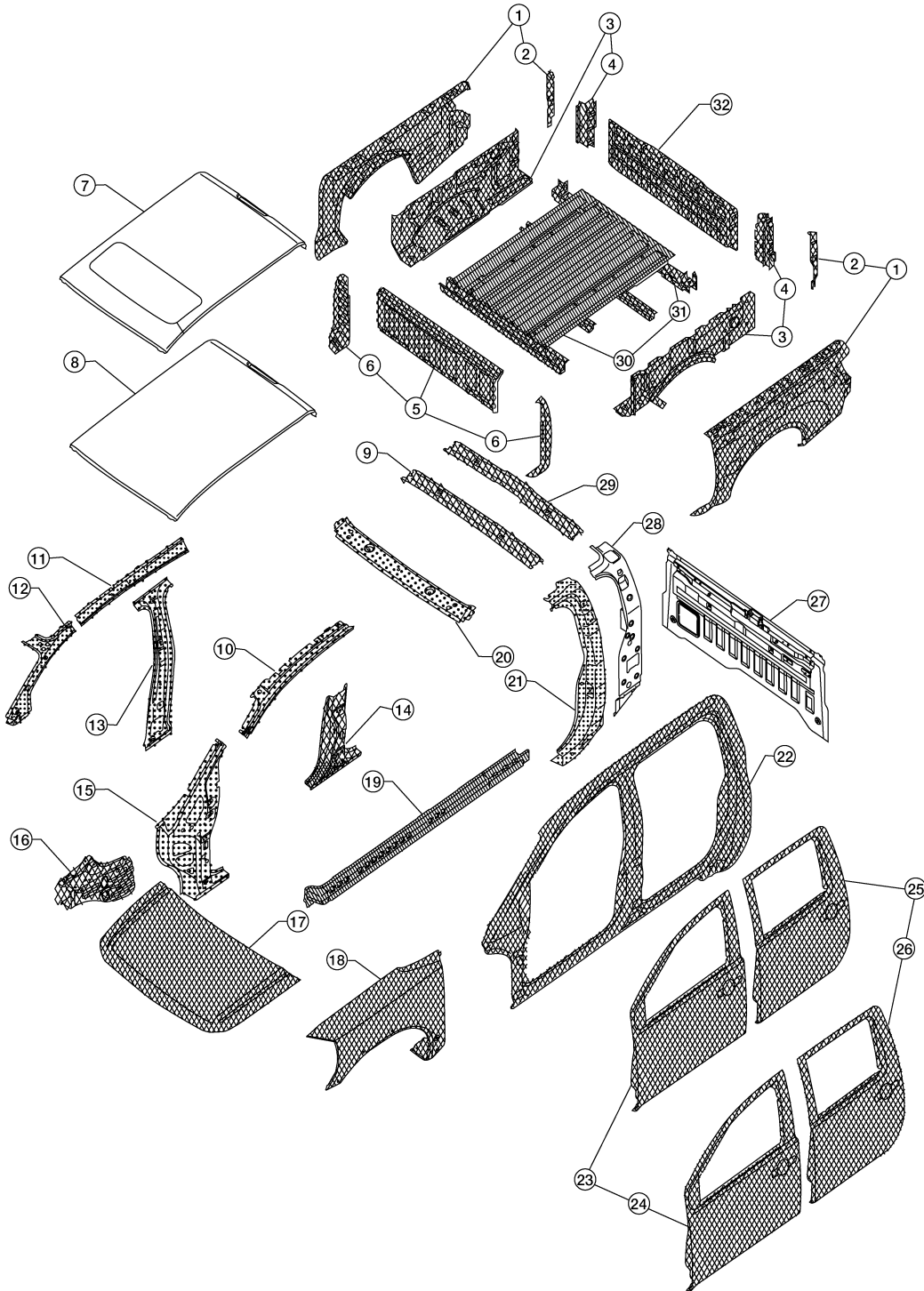

1. Side panel assembly (RH & LH)
2. Inner rear strut assembly (RH & LH)
3. Inner side panel assembly (RH & LH)
4. Rear strut assembly (RH & LH)
5. Header panel
6. Front outer strut assembly (RH & LH)

A
B
C
D
E
F
G
H
I
J
K
L
M
N
O
P

BRM

BODY COMPONENT PARTS

< UNIT REMOVAL AND INSTALLATION >

7. Roof with sunroof opening
8. Standard roof
9. No. 2 roof bow
10. Upper front pillar reinforcement (RH & LH)
11. Inner roof side rail (RH & LH)
12. Inner upper front pillar (RH & LH)
13. Inner center pillar (RH & LH)
14. Lower center pillar brace (RH & LH)
15. Front pillar brace (RH & LH)
16. Hoodledge rear reinforcement (RH & LH)
17. Hood
18. Front fender (RH & LH)
19. Outer sill reinforcement (RH & LH)
20. Front roof rail
21. Outer lock pillar reinforcement (RH & LH)
22. Body side outer (RH & LH)
23. Front door assembly (RH & LH)
24. Front door outer panel (RH & LH)
25. Rear door assembly (RH & LH)
26. Rear door outer panel (RH & LH)
27. Back panel assembly
28. Inner lock pillar (RH & LH)
29. Rear roof rail
30. Rear body floor assembly
31. Tail floor bolster assembly
32. Rear gate

FRAME COMPONENT PARTS

BODY COMPONENT PARTS

< UNIT REMOVAL AND INSTALLATION >

King Cab

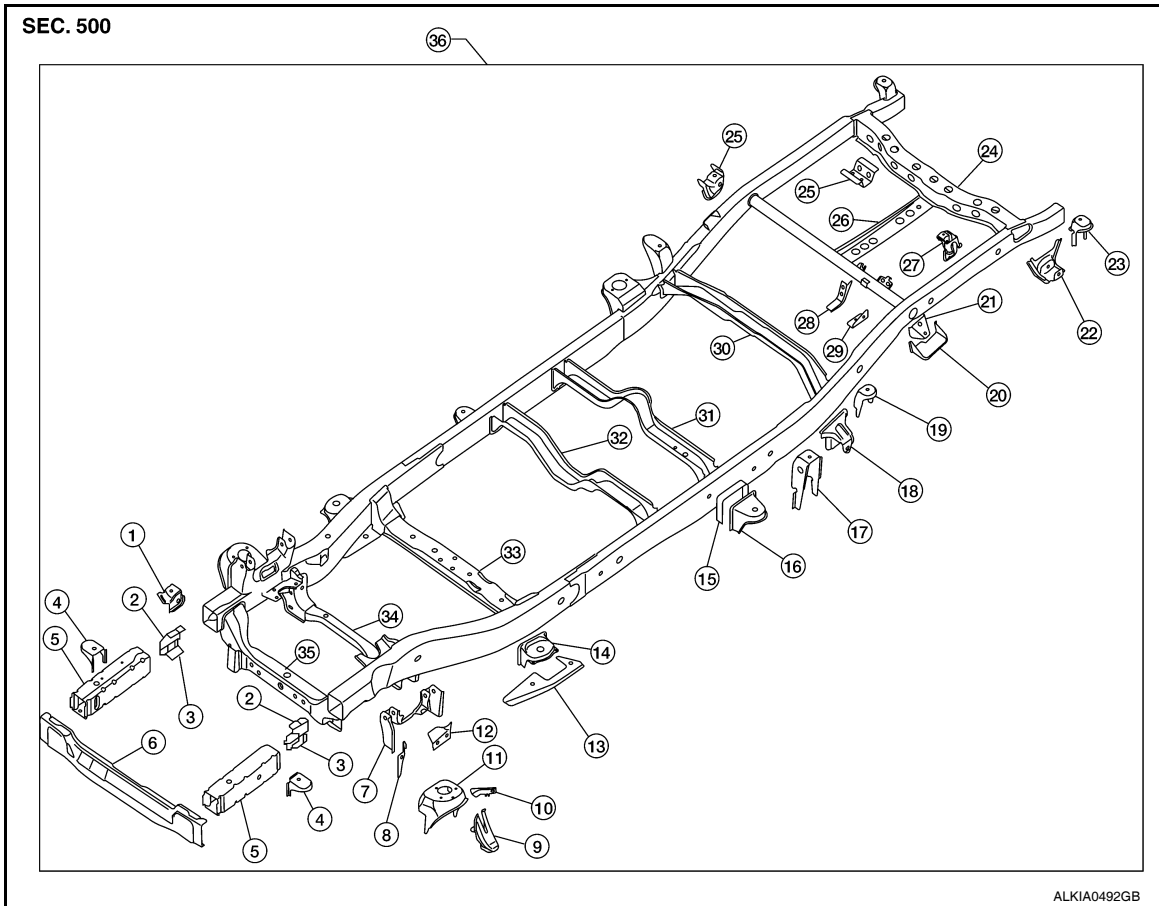

1. Front differential mounting bracket (RH & LH)
2. Upper front side member extension assembly (RH & LH)
3. Lower front side member extension assembly (RH & LH)
4. 1st cab mounting bracket (RH & LH)
5. Front side member extension assembly (RH & LH)
6. 1st crossmember assembly
7. Front link upper mounting bracket (RH & LH)
8. Panhard rod bracket reinforcement
9. Bound bumper bracket (RH & LH)
10. Front brake hose bracket (RH & LH)
11. Front shock absorber bracket (RH & LH)
12. Panhard rod reinforcement
13. 4th crossmember gusset (RH & LH)
14. 2nd cab mounting bracket (RH & LH)
15. 3rd cab mounting reinforcement
16. 3rd cab mounting bracket (RH & LH)
17. 1st rear body mounting bracket (RH & LH)
18. Rear spring front bracket assembly (RH & LH)
19. 2nd rear body mounting bracket (RH & LH)
20. Rear bound bumper bracket (RH & LH)
21. Rear bound bumper reinforcement (RH & LH)
22. Rear spring rear bracket assembly (RH & LH)
23. 5th rear body mounting bracket (RH & LH)

A
B
C
D
E
F
G
H
I
J
L
M
N
O
P

BRM

BODY COMPONENT PARTS

< UNIT REMOVAL AND INSTALLATION >

24. 9th crossmember assembly
25. Exhaust bracket assembly
26. 8th crossmember assembly
27. Rear shock absorber bracket assembly (RH & LH)
28. Canister bracket, RH
29. Canister bracket, LH
30. 7th crossmember assembly
31. 6th crossmember assembly
32. 5th crossmember assembly
33. 4th crossmember assembly
34. 3rd crossmember assembly
35. 2nd crossmember assembly
36. Frame assembly

Crew Cab

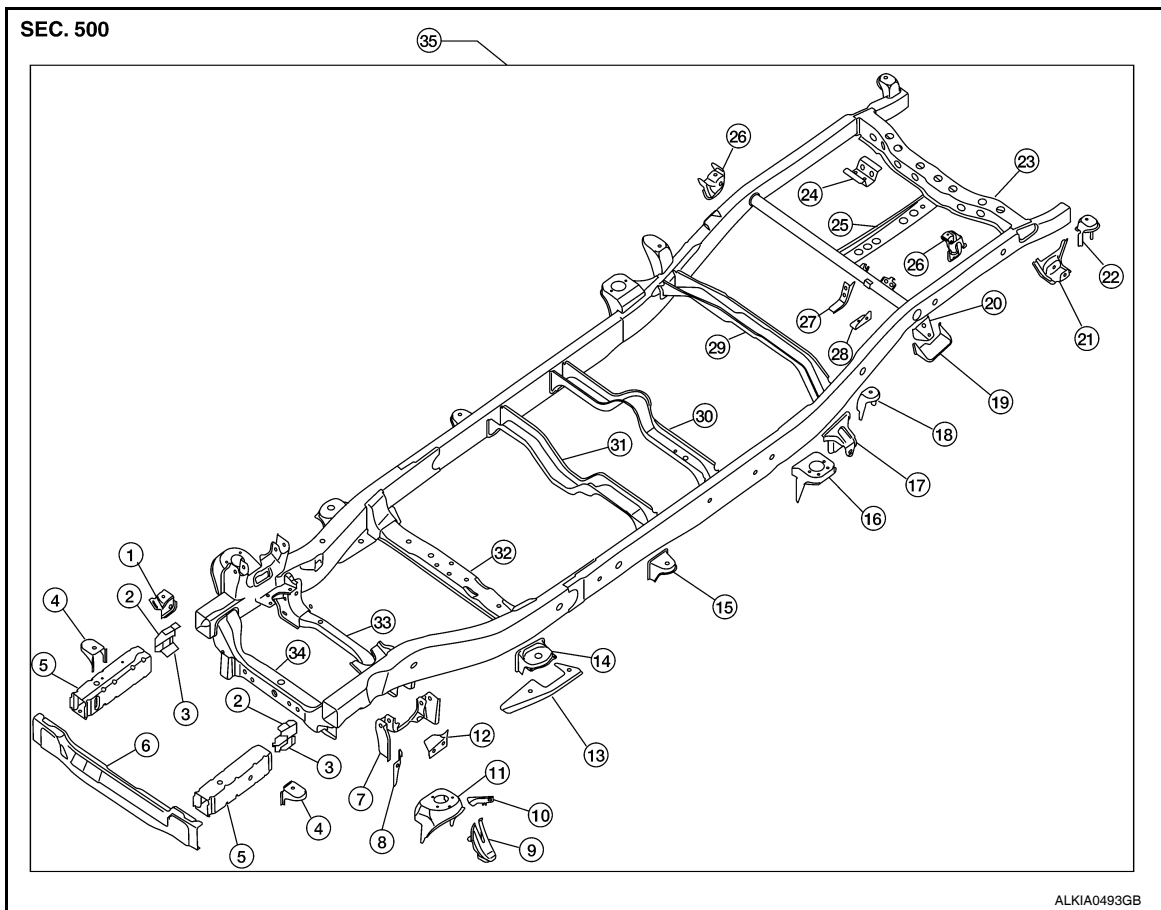

1. Front differential mounting bracket (RH & LH)
2. Upper front side member extension assembly (RH & LH)
3. Lower front side member extension assembly (RH & LH)
4. 1st cab mounting bracket (RH & LH)
5. Front side member extension assembly (RH & LH)
6. 1st crossmember assembly
7. Front link upper mounting bracket (RH & LH)
8. Panhard rod bracket reinforcement
9. Bound bumper bracket (RH & LH)

BODY COMPONENT PARTS

< UNIT REMOVAL AND INSTALLATION >

10. Front brake hose bracket (RH & LH)	A
11. Front shock absorber bracket (RH & LH)	
12. Panhard rod reinforcement	
13. 4th crossmember gusset (RH & LH)	B
14. 2nd cab mounting bracket (RH & LH)	
15. 3rd cab mounting bracket (RH & LH)	
16. 4th cab mounting bracket (RH & LH)	C
17. Rear spring front bracket assembly (RH & LH)	
18. 2nd rear body mounting bracket (RH & LH)	
19. Rear bound bumper bracket (RH & LH)	D
20. Rear bound bumper reinforcement (RH & LH)	
21. Rear spring rear bracket assembly (RH & LH)	
22. 5th rear body mounting bracket (RH & LH)	E
23. 9th crossmember assembly	
24. Exhaust bracket assembly	
25. 8th crossmember assembly	F
26. Rear shock absorber bracket assembly (RH & LH)	
27. Canister bracket, RH	
28. Canister bracket, LH	G
29. 7th crossmember assembly	
30. 6th crossmember assembly	H
31. 5th crossmember assembly	
32. 4th crossmember assembly	
33. 3rd crossmember assembly	I
34. 2nd crossmember assembly	
35. Frame assembly	J

BRM

L

M

N

O

P

CORROSION PROTECTION

< UNIT REMOVAL AND INSTALLATION >

CORROSION PROTECTION

Body Sealing

INFOID:000000006158465

DESCRIPTION

The following figure shows the areas which are sealed at the factory. Sealant which has been applied to these areas should be smooth and free from cuts or gaps. Care should be taken not to apply an excess amount of sealant and not to allow other unaffected parts to come into contact with the sealant.

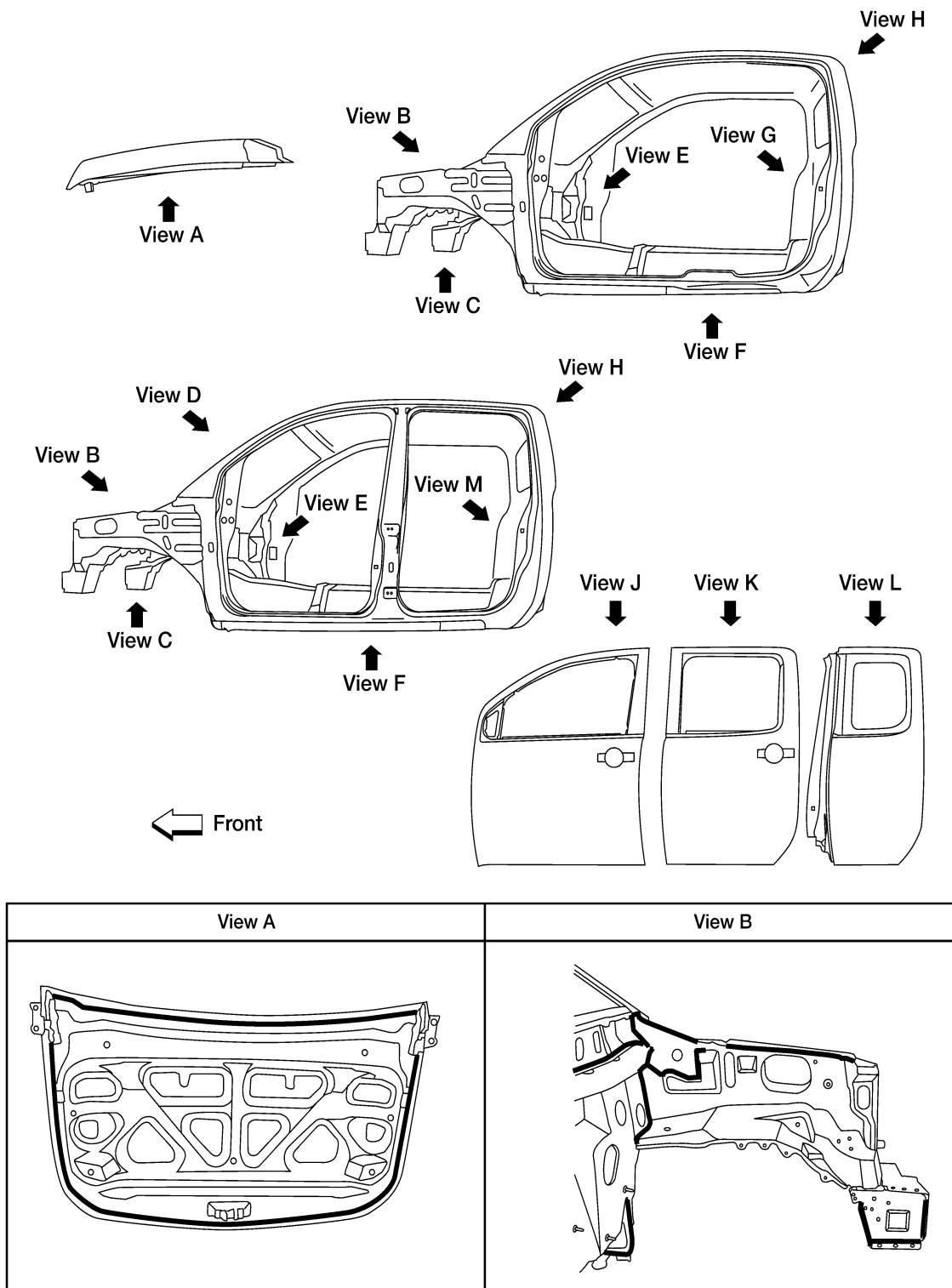

LIIA1303E

CORROSION PROTECTION

< UNIT REMOVAL AND INSTALLATION >

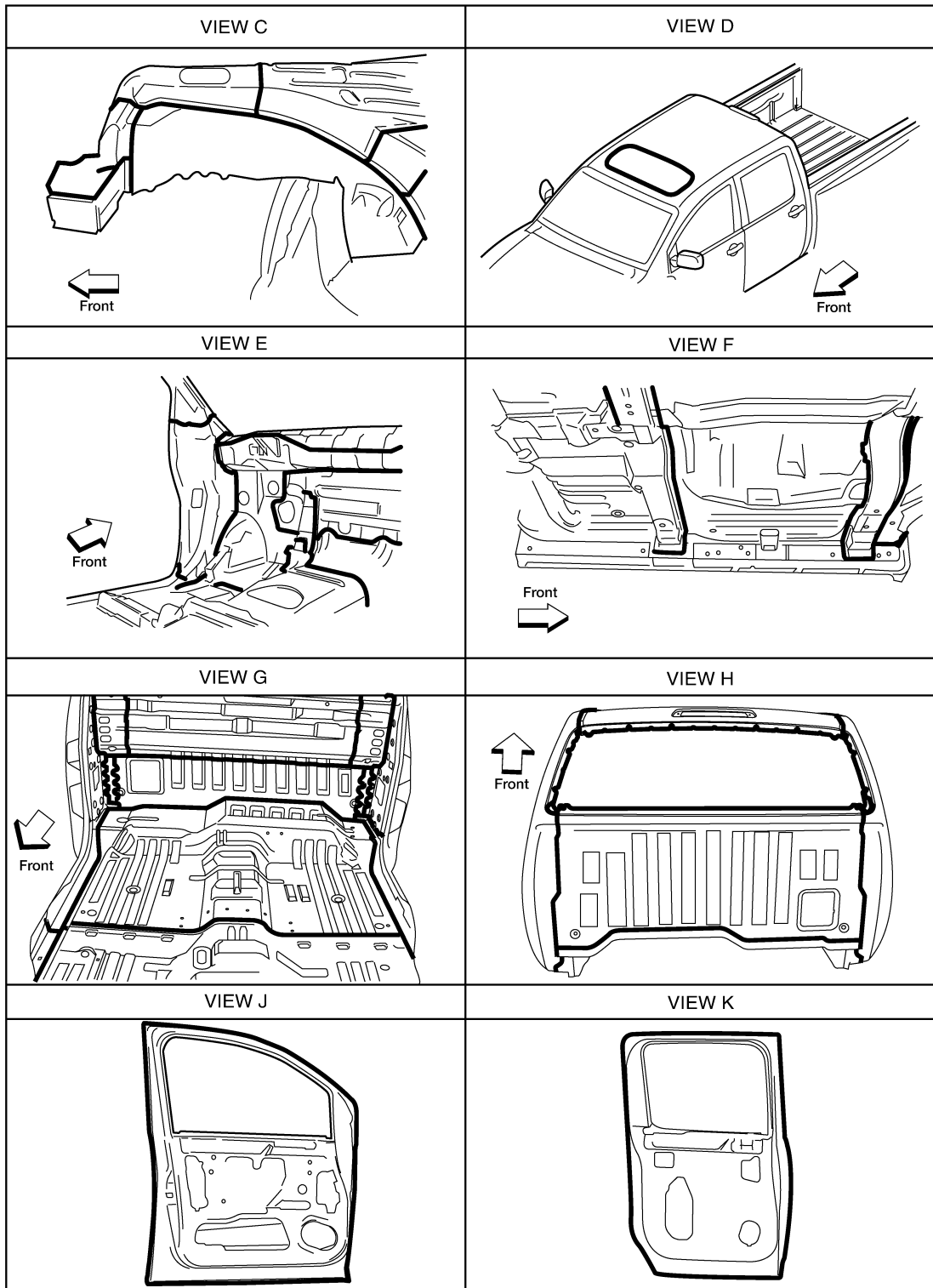

A
B
C
D
E
F
G
H
I
J
L
M
N
O
P

BRM

AWKIA0005GB

CORROSION PROTECTION

< UNIT REMOVAL AND INSTALLATION >

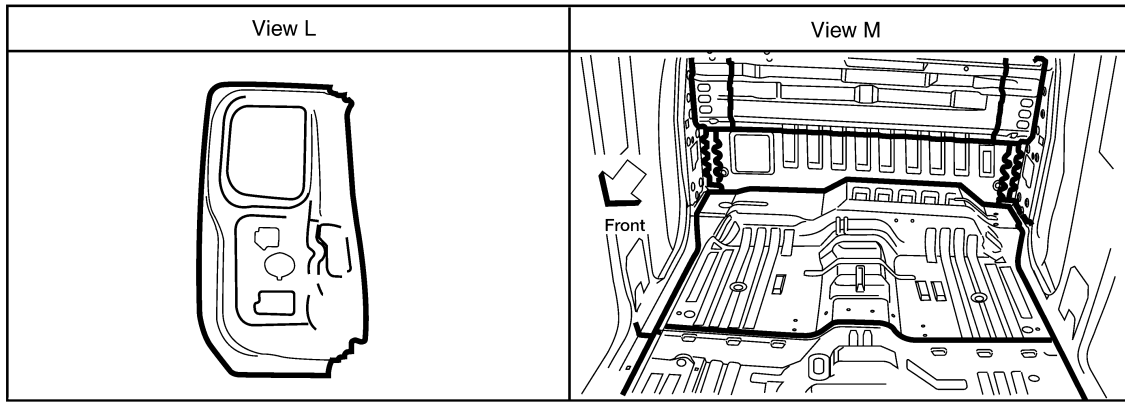

Corrosion Protection

LIIA1316E

INFOID:000000006158466

DESCRIPTION

To provide improved corrosion prevention, the following anti-corrosive measures have been implemented in NISSAN production plants. When repairing or replacing body panels, it is necessary to use the same anti-corrosive measures.

ANTI-CORROSIVE PRECOATED STEEL (GALVANNEALED STEEL)

CORROSION PROTECTION

< UNIT REMOVAL AND INSTALLATION >

To improve reparability and corrosion resistance, a new type of anti-corrosive precoated steel sheet has been adopted replacing conventional zinc-coated steel sheet.

Galvannealed steel is electroplated and heated to form Zinc-iron alloy, which provides excellent and long term corrosion resistance with cationic electrode position primer.

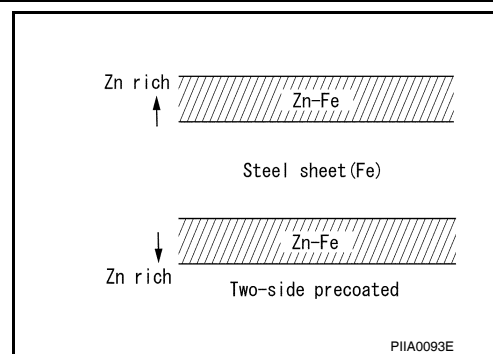

Nissan Genuine Service Parts are fabricated from galvannealed steel. Therefore, it is recommended that GENUINE NISSAN PARTS or equivalent be used for panel replacement to maintain the anti-corrosive performance built into the vehicle at the factory.

PHOSPHATE COATING TREATMENT AND CATIONIC ELECTRODEPOSITION PRIMER

A phosphate coating treatment and a cationic electrode position primer, which provide excellent corrosion protection, are employed on all body components.

CAUTION:

Confine paint removal during welding operations to an absolute minimum.

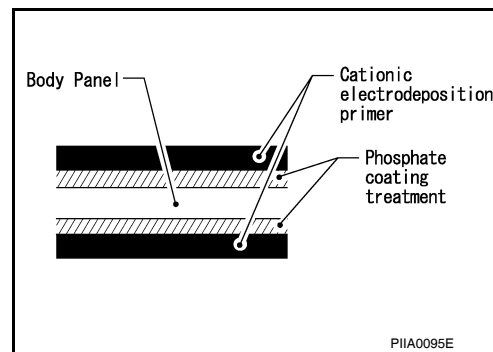

Nissan Genuine Service Parts are also treated in the same manner. Therefore, it is recommended that GENUINE NISSAN PARTS or equivalent be used for panel replacement to maintain anti-corrosive performance built into the vehicle at the factory.

ANTI-CORROSIVE WAX



To improve corrosion resistance, anti-corrosive wax is applied inside the body sill and inside other closed sections. Accordingly, when replacing these parts, be sure to apply anti-corrosive wax to the appropriate areas of

CORROSION PROTECTION

< UNIT REMOVAL AND INSTALLATION >

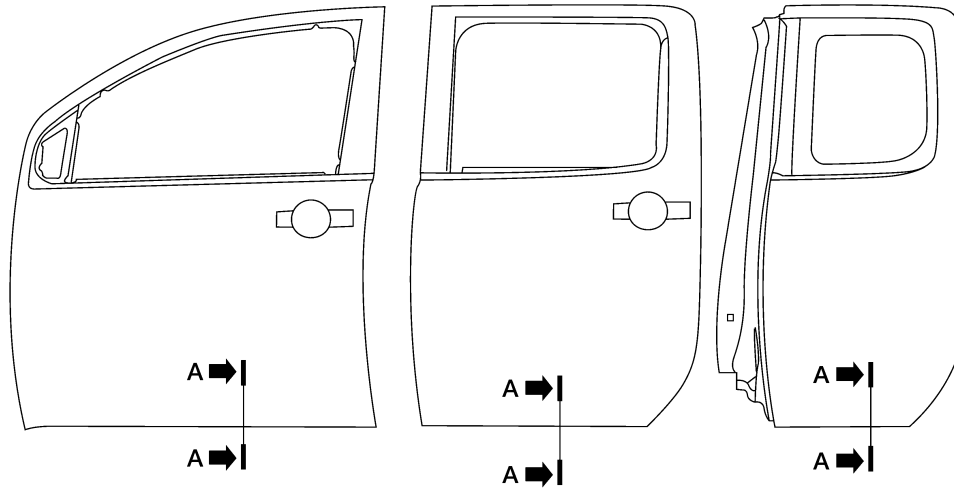
the new parts. Select an excellent anti-corrosive wax which will penetrate after application and has a long shelf life.



-  : Indicates outside body sealant
-  : Indicates anti-corrosive wax coated portions

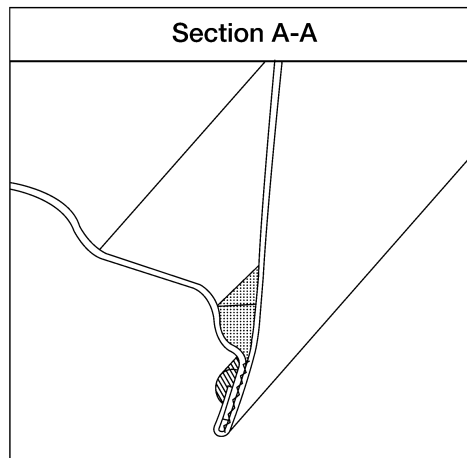

LIIA1210E

UNDERCOATING

The underside of the floor and wheelhouse are undercoated to prevent rust, vibration, noise and stone chipping. Therefore, when such a panel is replaced or repaired, apply undercoating to that part. Use an undercoating which is rust preventive, soundproof, vibration-proof, shock-resistant, adhesive, and durable.

Precautions in undercoating

1. Do not apply undercoating to any place unless specified (such as the areas above the muffler and three way catalyst which are subjected to heat).
2. Do not undercoat the exhaust pipe or other parts which become hot.
3. Do not undercoat rotating parts.

CORROSION PROTECTION

< UNIT REMOVAL AND INSTALLATION >

4. Apply bitumen wax after applying undercoating.

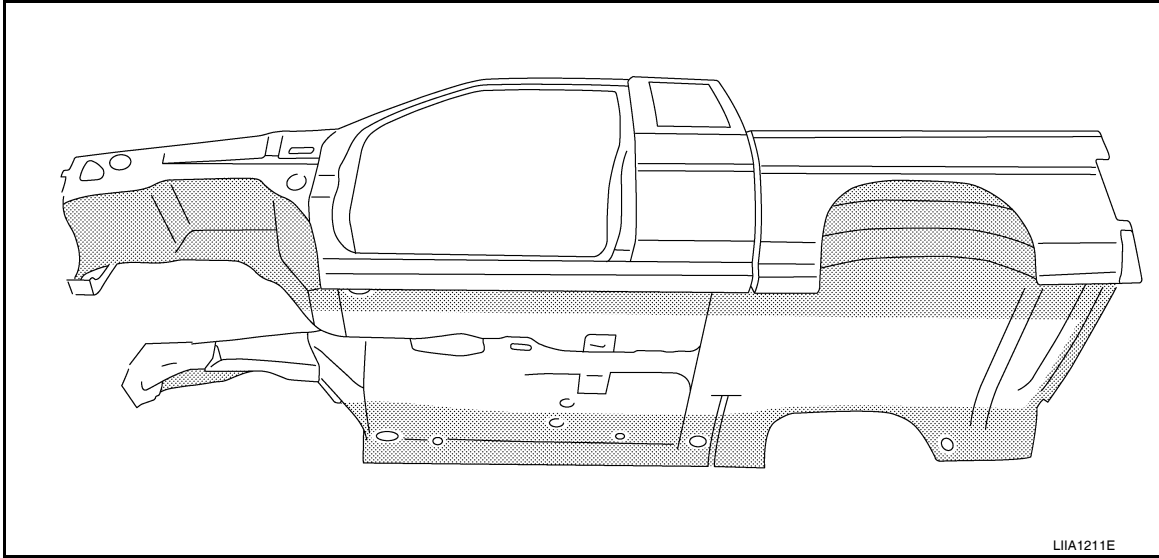

A

B

C

D

E

F

G

H

I

J

BRM

L

M

N

O

P

BODY CONSTRUCTION

< UNIT REMOVAL AND INSTALLATION >

BODY CONSTRUCTION

Body Construction

INFOID:000000006158467

BODY CONSTRUCTION

King Cab

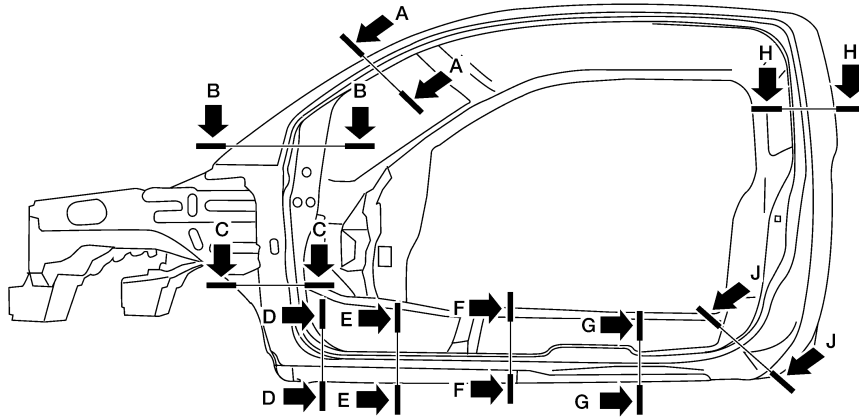

Section A-A	Section B-B	Section C-C	Section D-D
Section E-E	Section F-F	Section G-G	Section H-H
Section J-J			

LIIA1317E

BODY CONSTRUCTION

< UNIT REMOVAL AND INSTALLATION >

Crew Cab

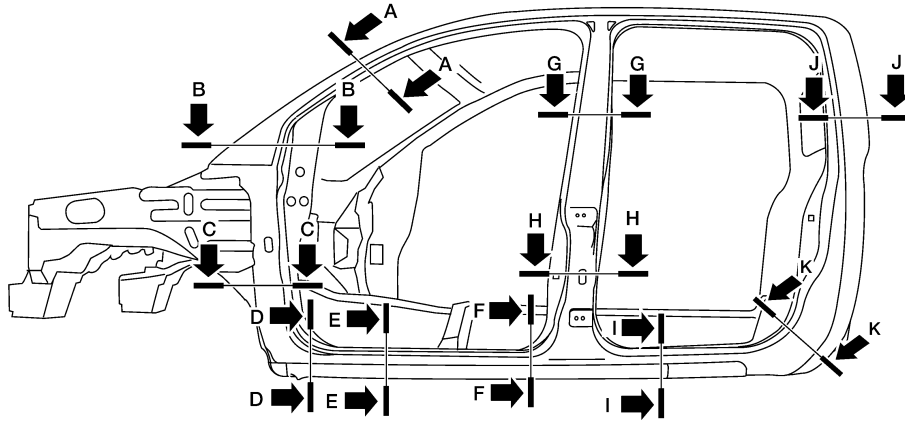

Section A-A	Section B-B	Section C-C	Section D-D
Section E-E	Section F-F	Section G-G	Section H-H
Section I-I	Section J-J	Section K-K	

LIA1318E

A
B
C
D
E
F
G
H
I
J
K
L
M
N
O
P

BRM

BODY CONSTRUCTION

< UNIT REMOVAL AND INSTALLATION >

Body Mounting, King Cab

INFOID:000000006158468

When removing, be sure to replace bolts and nuts (sealant applied bolts or self-lock nuts are used for all mounting).

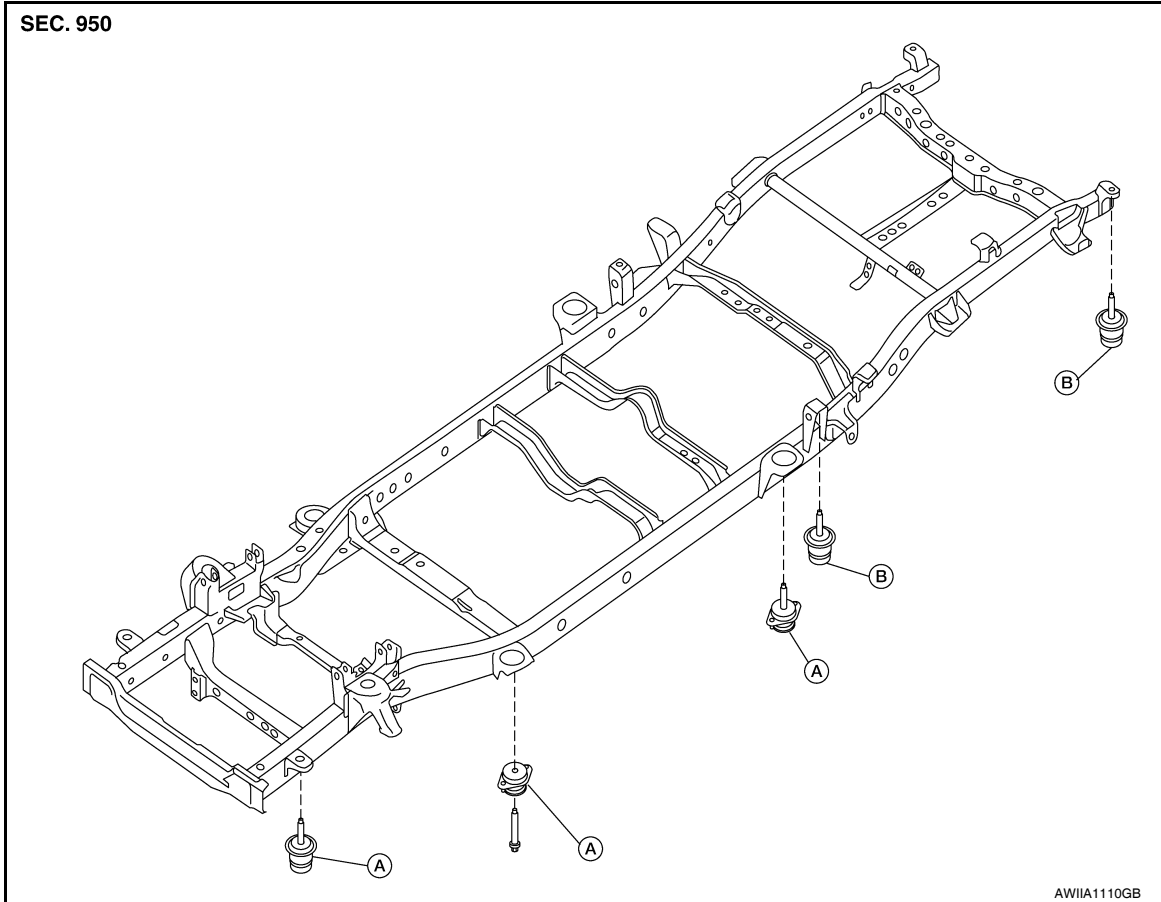

Frame to Cab (A) : 87.5 N·m (8.9 kg-m, 65 ft-lb)
Frame to Bed (B) : 21.6 N·m (2.2 kg-m, 16 ft-lb)

BODY CONSTRUCTION

< UNIT REMOVAL AND INSTALLATION >

Body Mounting, Crew Cab

INFOID:000000006158469

When removing, be sure to replace bolts and nuts (sealant applied bolts or self-lock nuts are used for all mounting).

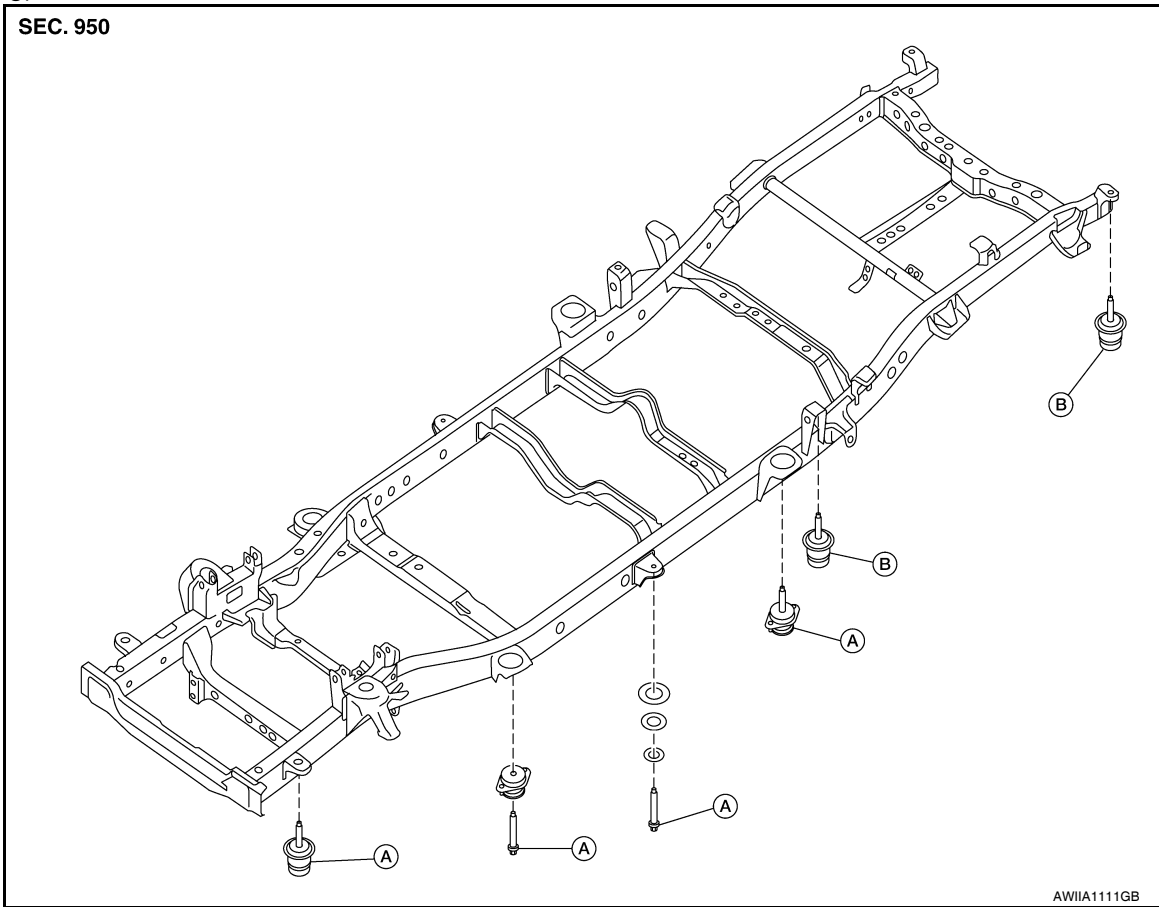

- | | |
|-------------------------|--|
| Frame to Cab (A) | : 87.5 N·m (8.9 kg-m, 65 ft-lb) |
| Frame to Bed (B) | : 21.6 N·m (2.2 kg-m, 16 ft-lb) |

Rear Body

INFOID:000000006158470

REMOVAL AND INSTALLATION

A
B
C
D
E
F
G
H
I
J

BRM

L
M
N
O
P

BODY CONSTRUCTION

< UNIT REMOVAL AND INSTALLATION >

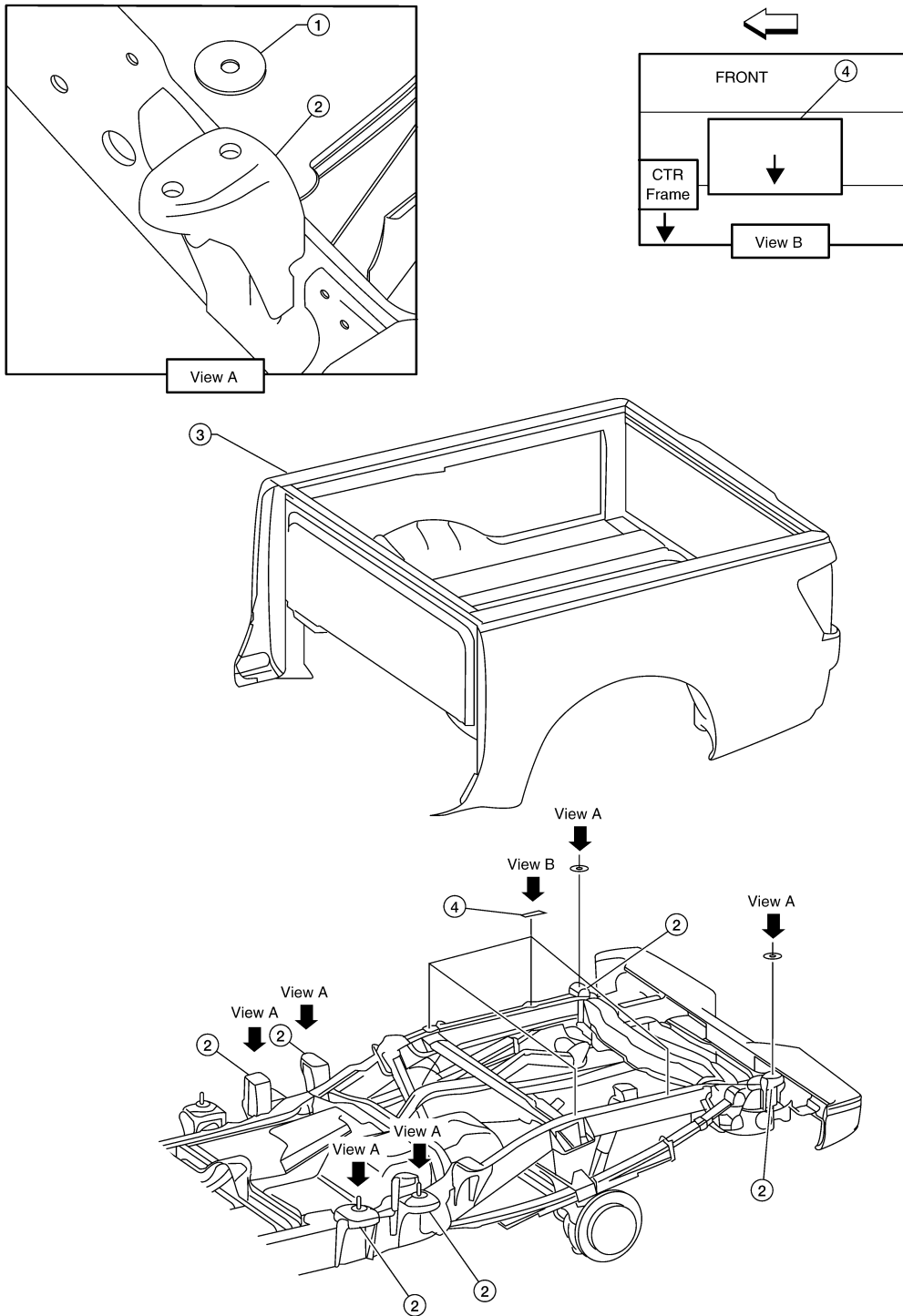

LIIA2153E

1. Shim (pick-up bed mount)
2. Body rear mount
3. Pick-up bed assembly
4. Shim (bed floor crossmember)

Removal

1. If equipped, remove the floor rails. Refer to [EXT-31, "Removal and Installation"](#).
2. Disconnect both of the rear combination lamp wire harnesses.
3. If equipped, remove the bed power point. Refer to [PWO-7, "Removal and Installation"](#).

BODY CONSTRUCTION

< UNIT REMOVAL AND INSTALLATION >

4. Disconnect the fuel filler neck from the bed side outer.
5. Remove the rear bumper assembly.
6. Remove the pick-up bed assembly.

Installation

Installation is in the reverse order of removal.

- Shim as necessary for proper fit and finish.

Foam Repair

INFOID:000000006158471

During factory body assembly, foam insulators are installed in certain body panels and locations around the vehicle. Use the following procedure(s) to replace any factory-installed foam insulators.

URETHANE FOAM APPLICATIONS

Use commercially available spray foam for sealant (foam material) repair of material used on vehicle. Read instructions on product for fill procedures.

FILL PROCEDURES

1. Fill procedures after installation of service part.
 - Remove foam material remaining on vehicle side.
 - Clean area in which foam was removed.
 - Install service part.
 - Insert nozzle into hole near fill area and fill foam material or fill in enough to close gap with the service part.

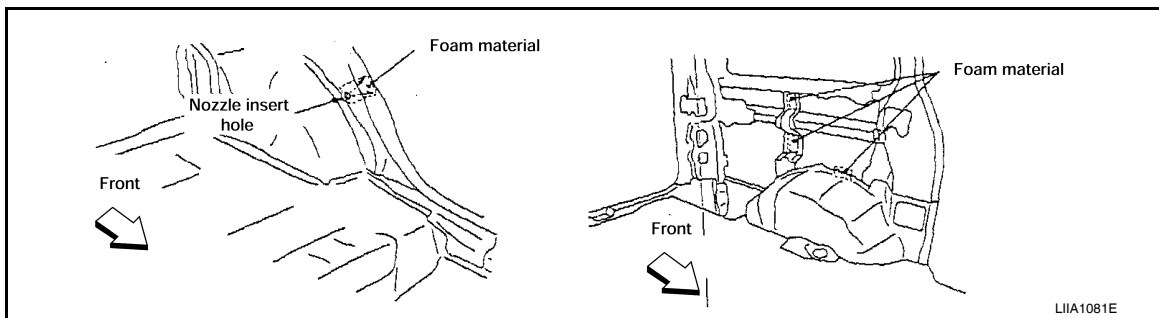

2. Fill procedures before installation of service part.
 - Remove foam material remaining on vehicle side.
 - Clean area in which foam was removed.
 - Fill foam material on wheelhouse outer side.

NOTE:

Fill in enough to close gap with service part while avoiding flange area.

- Install service part.

NOTE:

Refer to label for information on working times.

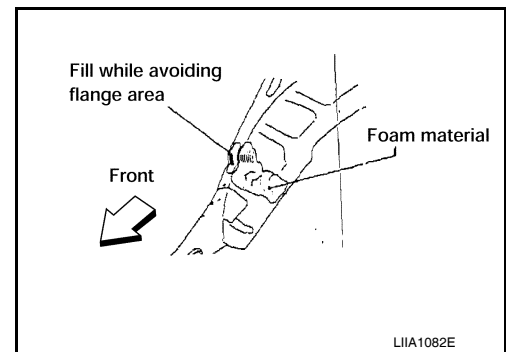

A
B
C
D
E
F
G
H
I
J
L
M
N
O
P

BRM

BODY ALIGNMENT

< UNIT REMOVAL AND INSTALLATION >

BODY ALIGNMENT

Body Alignment

INFOID:000000006158472

BODY CENTER MARKS

A mark has been placed on each part of the body to indicate the vehicle center. When repairing parts damaged by an accident which might affect the vehicle frame (members, pillars, etc.), more accurate and effective repair will be possible by using these marks together with body alignment specifications.

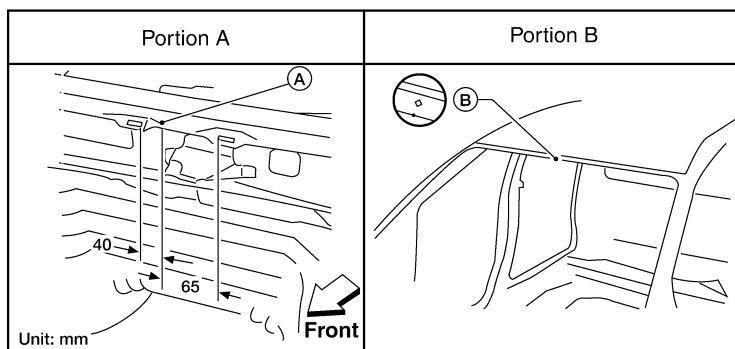
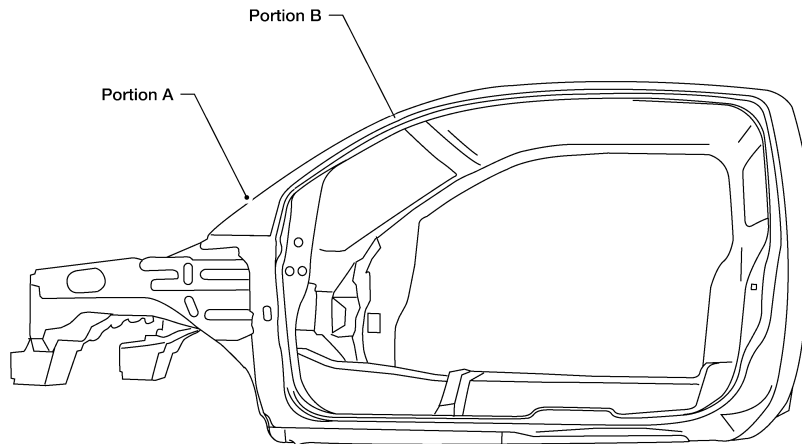
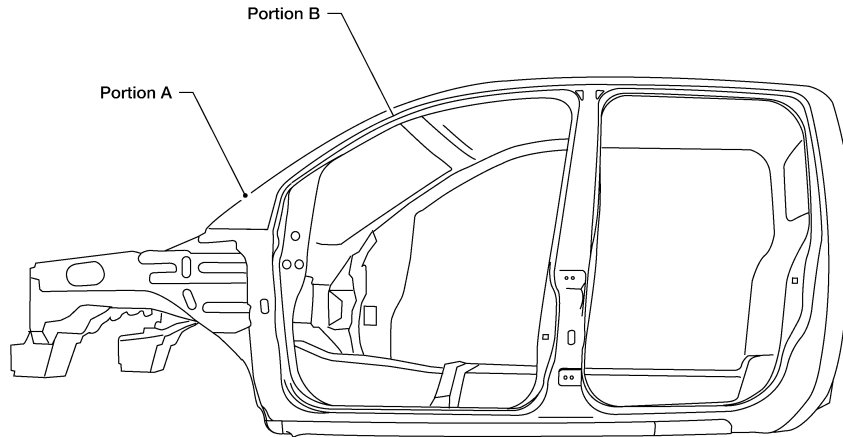

ALKIA0502GB

BODY ALIGNMENT

< UNIT REMOVAL AND INSTALLATION >

PANEL PARTS MATCHING MARKS

A mark has been placed on each body panel to indicate the parts matching positions. When repairing parts damaged by an accident which might affect the vehicle structure (members, pillars, etc.), more accurate and effective repair will be possible by using these marks together with body alignment specifications.

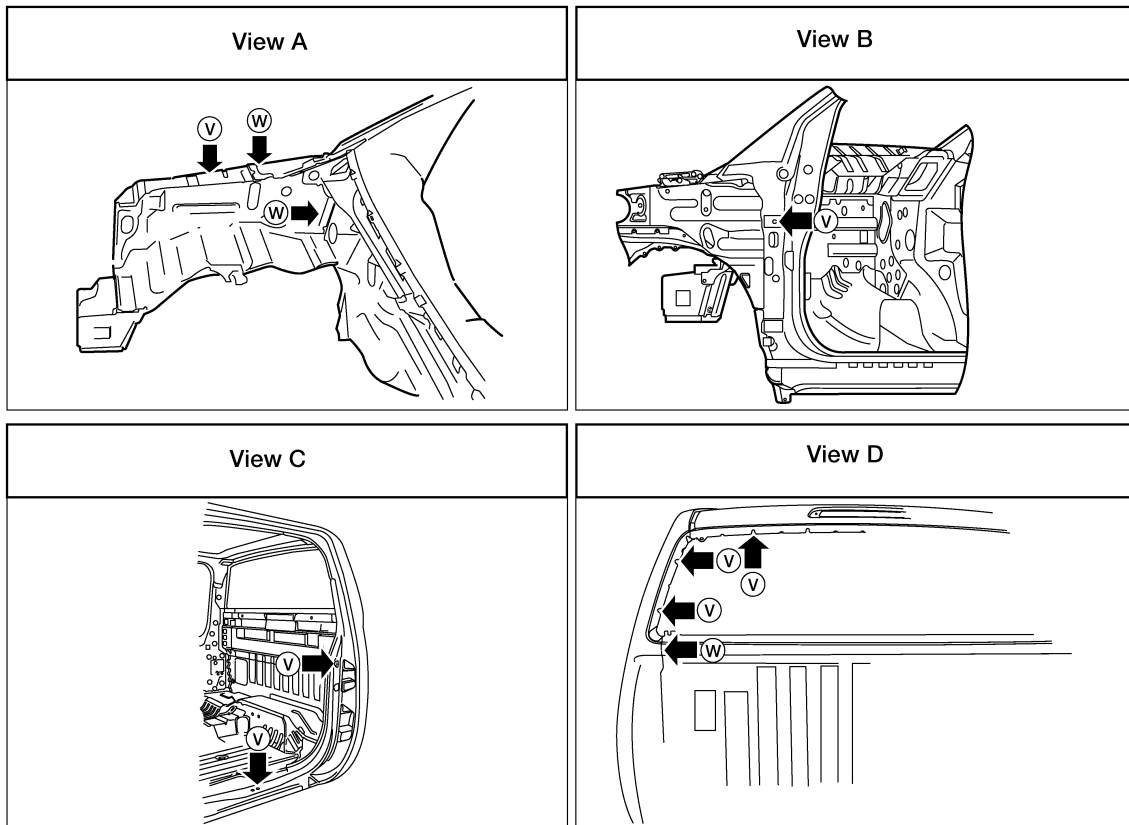
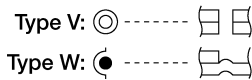
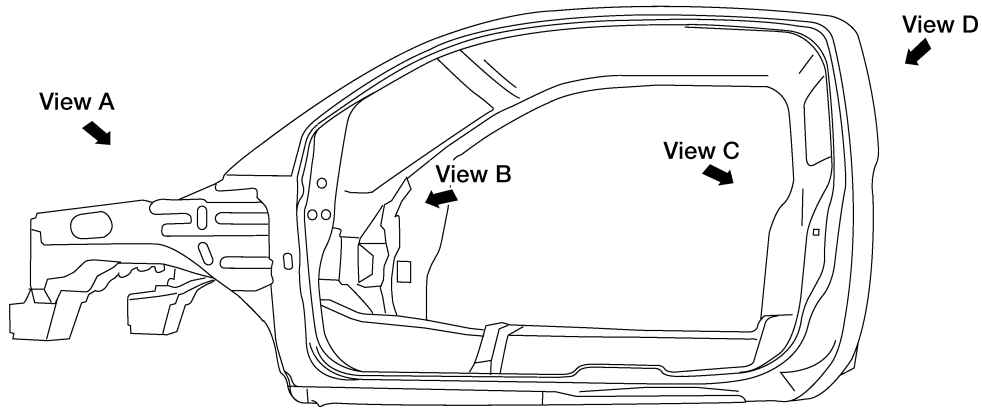

WIA0338E

DESCRIPTION

- All dimensions indicated in the figures are actual.
- When using a tracking gauge, adjust both pointers to equal length. Then check the pointers and gauge itself to make sure there is no free play.

A
B
C
D
E
F
G
H
I
J
L
M
N
O
P

BRM

BODY ALIGNMENT

< UNIT REMOVAL AND INSTALLATION >

- When a measuring tape is used, check to be sure there is no elongation, twisting or bending.
- Measurements should be taken at the center of the mounting holes.
- An asterisk (*) following the value at the measuring point indicates that the measuring point on the other side is symmetrically the same value.
- The coordinates of the measurement points are the distances measured from the standard line of "X", "Y" and "Z".

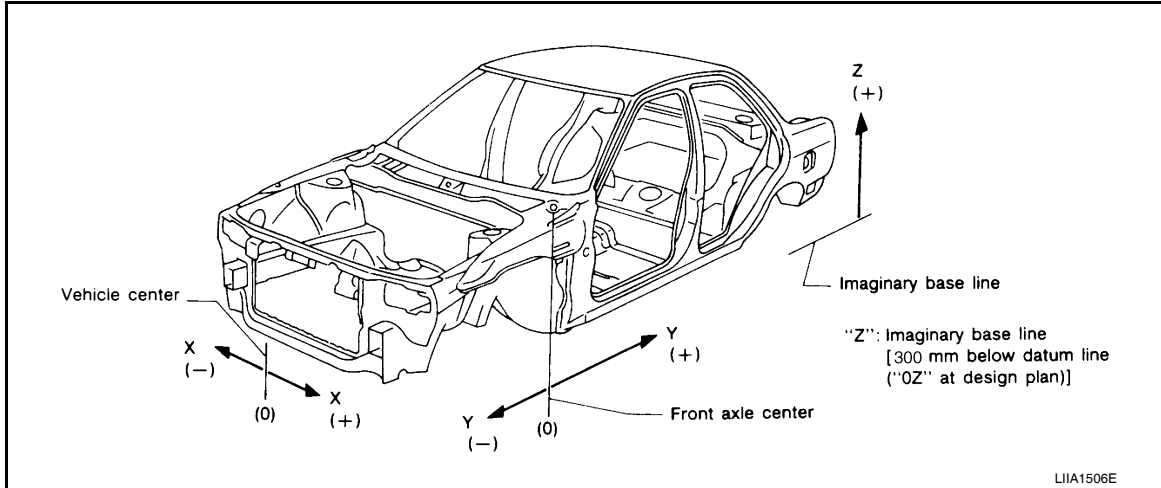

Engine Compartment

BODY ALIGNMENT

< UNIT REMOVAL AND INSTALLATION >

MEASUREMENT

Figures marked with a (*) indicate symmetrically identical dimensions on both right and left hand sides of the vehicle.

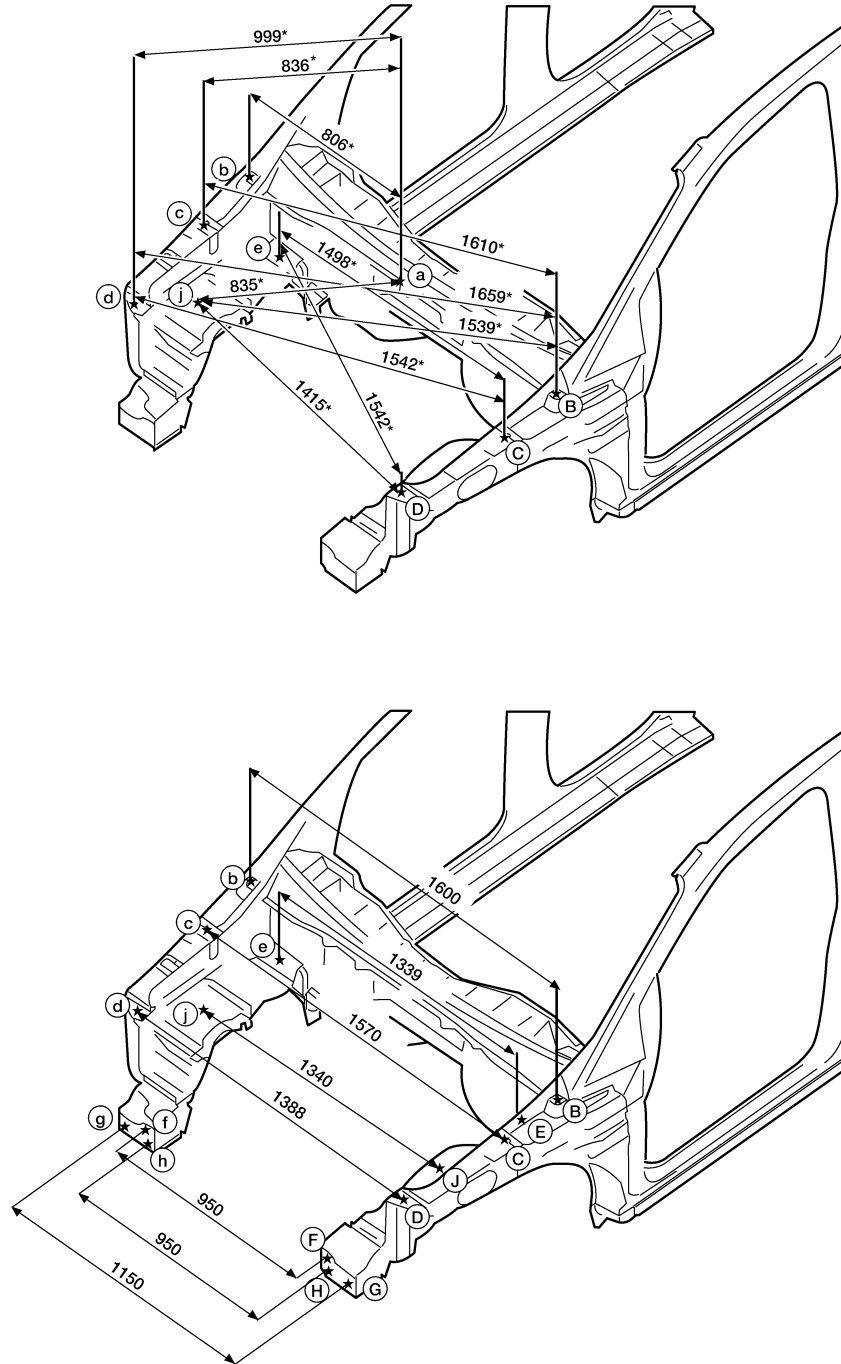

Unit: mm

AWI1A1088GB

A
B
C
D
E
F
G
H
I
J
BRM
L
M
N
O
P

BODY ALIGNMENT

< UNIT REMOVAL AND INSTALLATION >

MEASUREMENT POINTS

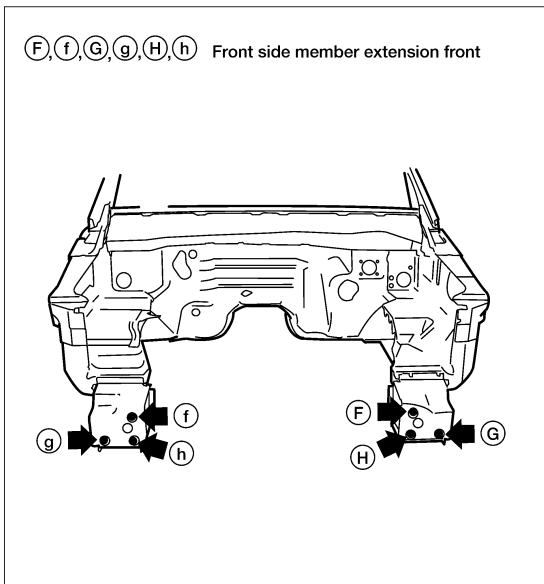
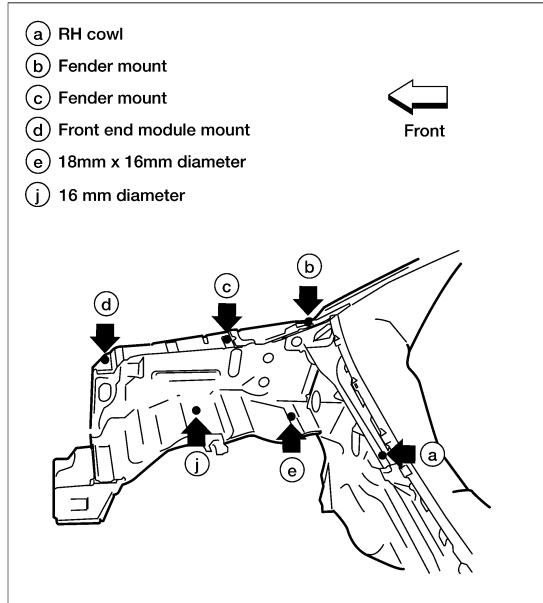
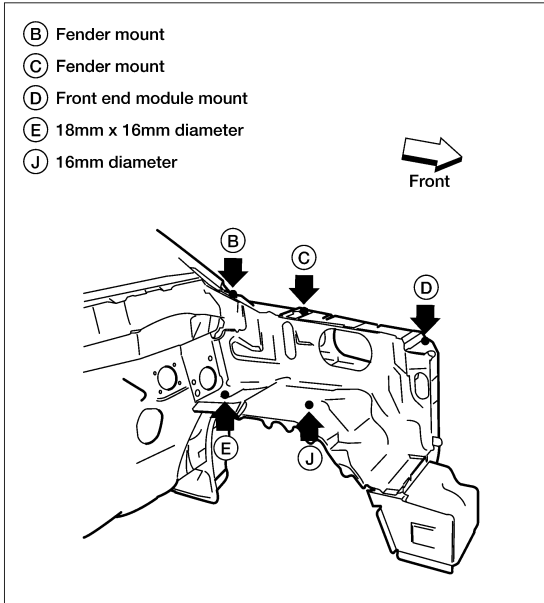

W11A0279E

Underbody, Short Bed

BODY ALIGNMENT

< UNIT REMOVAL AND INSTALLATION >

MEASUREMENT POINTS

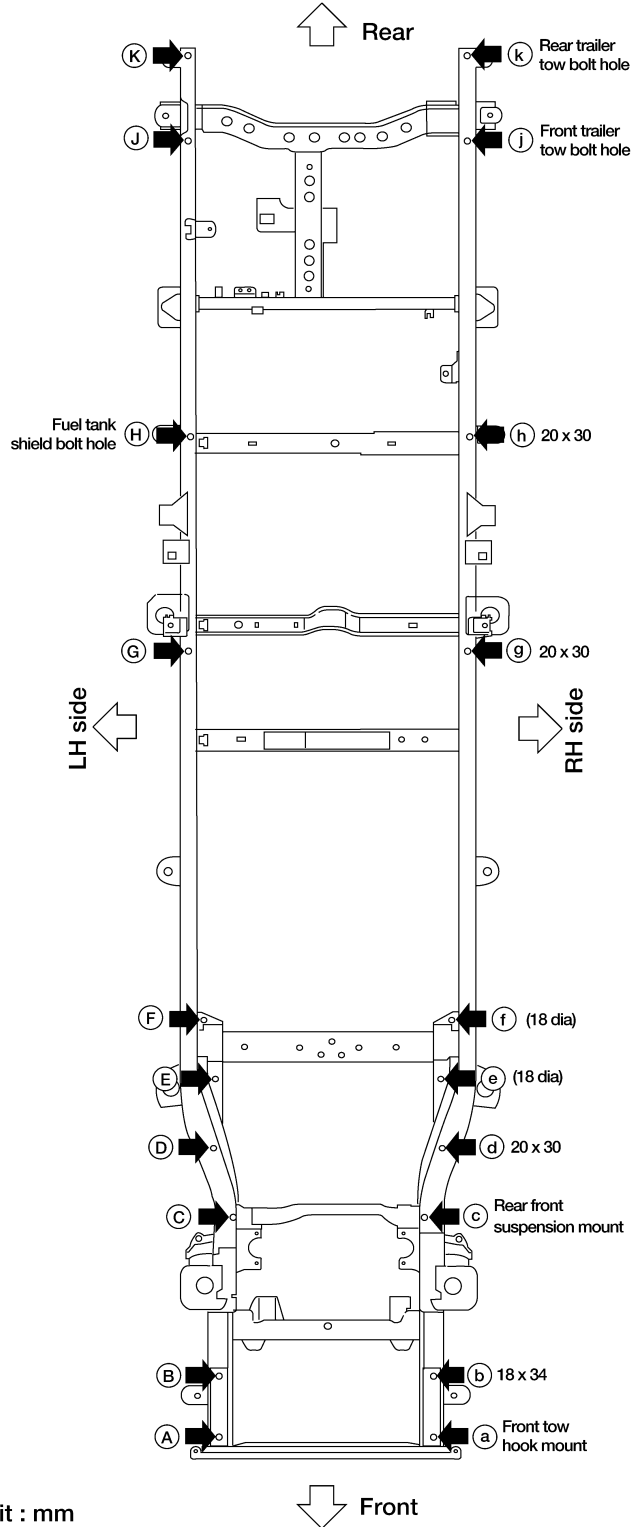

Coordinates:

- (A) (a)
X : ± 447
Y : -672
Z : 272
- (B) (b)
X : ± 447
Y : -427
Z : 272
- (C) (c)
X : ± 386
Y : 198
Z : 165
- (D) (d)
X : ± 457
Y : 504
Z : 115
- (E) (e)
X : ± 466
Y : 777
Z : 100
- (F) (f)
X : ± 495
Y : 1013
Z : 100
- (G) (g)
X : ± 564
Y : 2543
Z : 79
- (H) (h)
X : ± 563
Y : 3452
Z : 163
- (J) (j)
X : ± 558
Y : 4670
Z : 400
- (K) (k)
X : ± 559
Y : 5046
Z : 337

ALKIA0495GB

BODY ALIGNMENT

< UNIT REMOVAL AND INSTALLATION >

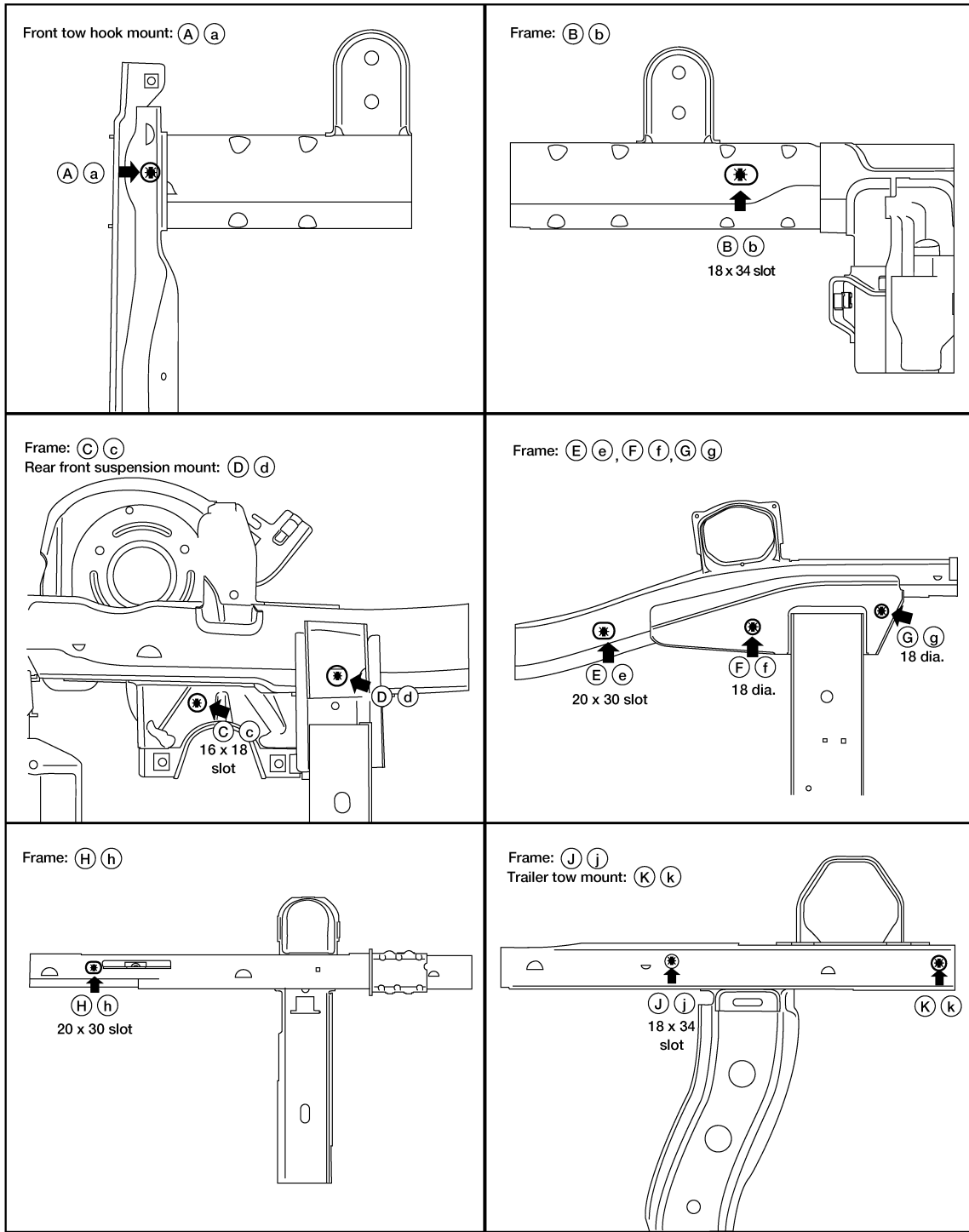

Coordinates: (A) a		(B) b		(C) c		(D) d		(E) e		(F) f		(G) g		(H) h		(J) j		(K) k						
X : ± 447	X : ± 447	X : ± 353	X : ± 386	X : ± 454	X : ± 466	X : ± 495	X : ± 564	X : ± 558	X : ± 559	Y : 777	Y : 1013	Y : 2541	Y : 4171	Y : 4546	Z : 255	Z : 272	Z : 303	Z : 165	Z : 115	Z : 100	Z : 100	Z : 88	Z : 400	Z : 337

Unit: mm

WJIA0340E

Underbody, Long Bed

A
B
C
D
E
F
G
H
I
J
K
L
M
N
O
P

BRM

BODY ALIGNMENT

< UNIT REMOVAL AND INSTALLATION >

LONG WHEELBASE MEASUREMENT

Figures marked with a (*) indicate symmetrically identical dimensions on both right and left hand sides of the vehicle.

As viewed from underside.

All dimensions indicated in this figure are actual.

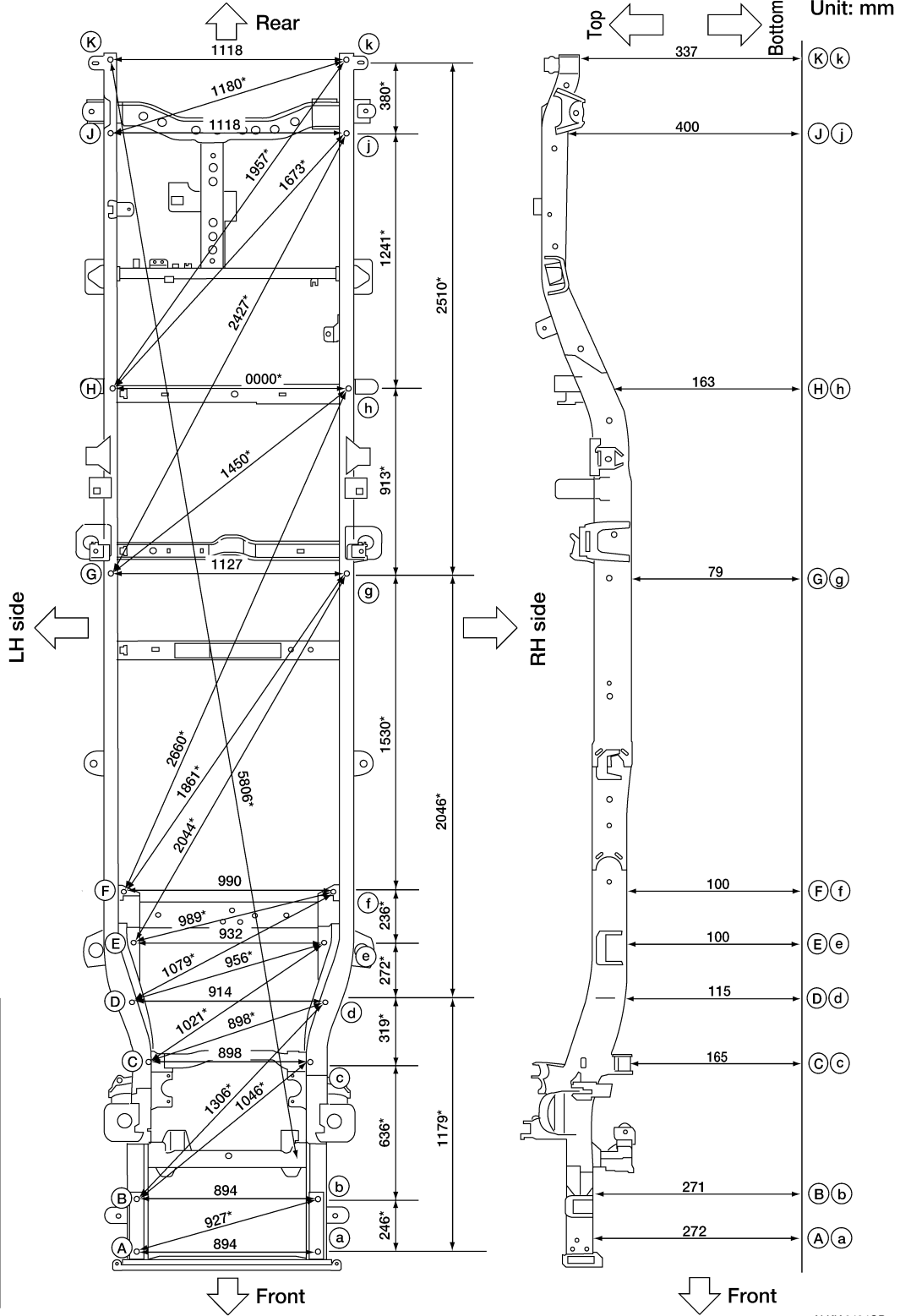

ALKIA0494GB

BODY ALIGNMENT

< UNIT REMOVAL AND INSTALLATION >

LONG WHEELBASE MEASUREMENT POINTS

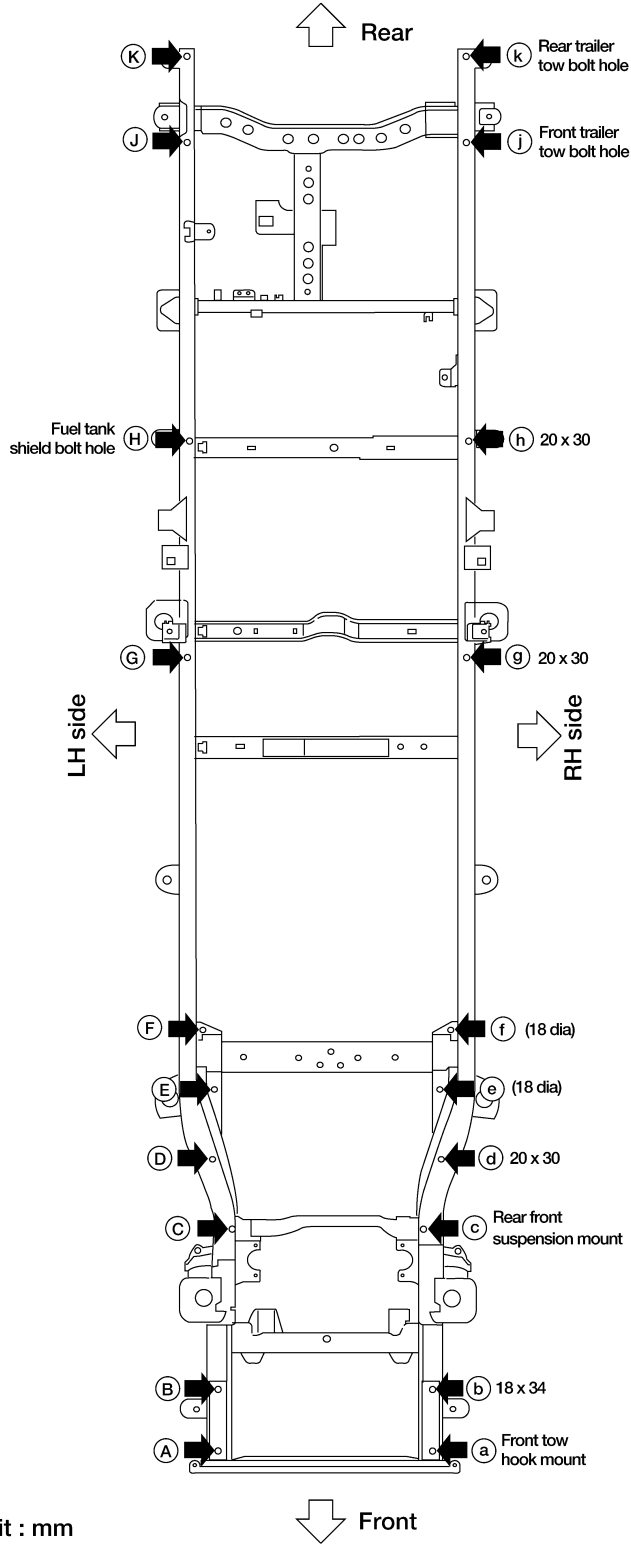

Coordinates:

- (A)(a)
X : ± 447
Y : -672
Z : 272
- (B)(b)
X : ± 447
Y : -427
Z : 272
- (C)(c)
X : ± 386
Y : 198
Z : 165
- (D)(d)
X : ± 457
Y : 504
Z : 115
- (E)(e)
X : ± 466
Y : 777
Z : 100
- (F)(f)
X : ± 495
Y : 1013
Z : 100
- (G)(g)
X : ± 564
Y : 2543
Z : 79
- (H)(h)
X : ± 563
Y : 3452
Z : 163
- (J)(j)
X : ± 558
Y : 4670
Z : 400
- (K)(k)
X : ± 559
Y : 5046
Z : 337

Unit : mm

ALKIA0495GB

A
B
C
D
E
F
G
H
I
J
J
L
M
N
O
P

BRM

BODY ALIGNMENT

< UNIT REMOVAL AND INSTALLATION >

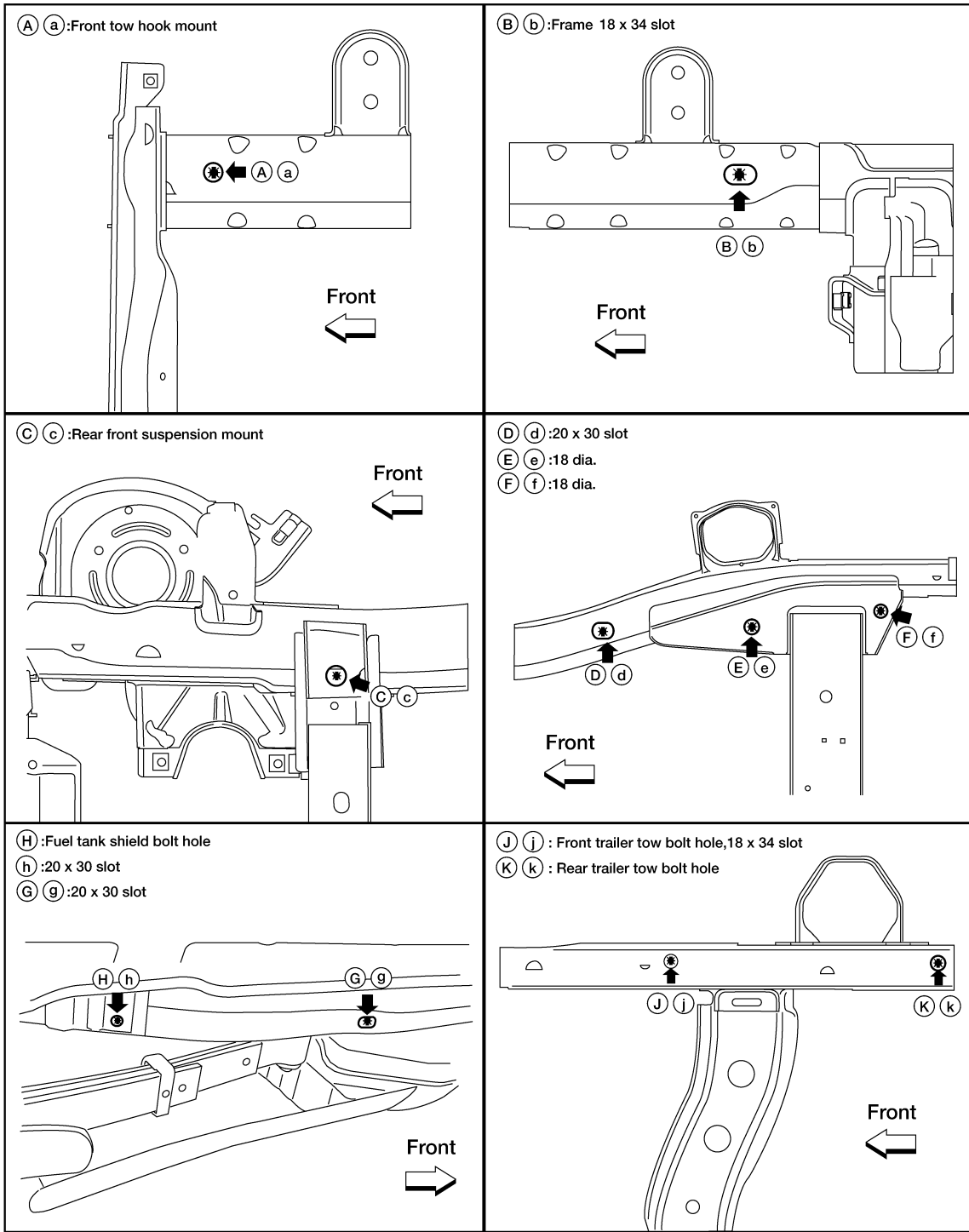

Coordinates:	(A) (a)	(B) (b)	(C) (c)	(D) (d)	(E) (e)	(F) (f)	(G) (g)	(H) (h)	(J) (j)	(K) (k)
X :	± 447	± 447	± 386	± 457	± 466	± 495	± 564	± 563	± 558	± 559
Y :	-672	-427	198	504	777	1013	2543	3452	4670	5046
Z :	272	272	165	115	100	100	79	163	400	337

Unit: mm

ALKIA0496GB

Passenger Compartment

MEASUREMENT

BODY ALIGNMENT

< UNIT REMOVAL AND INSTALLATION >

Windshield Opening

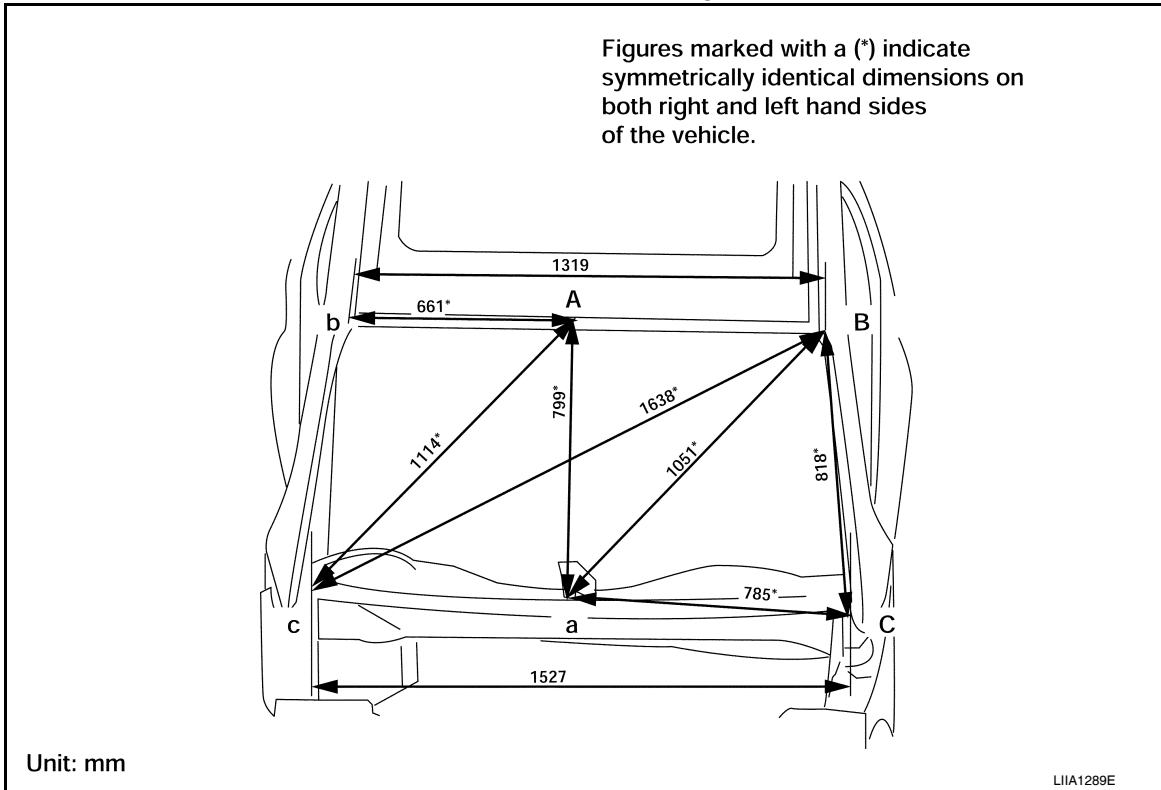

King Cab Door Opening

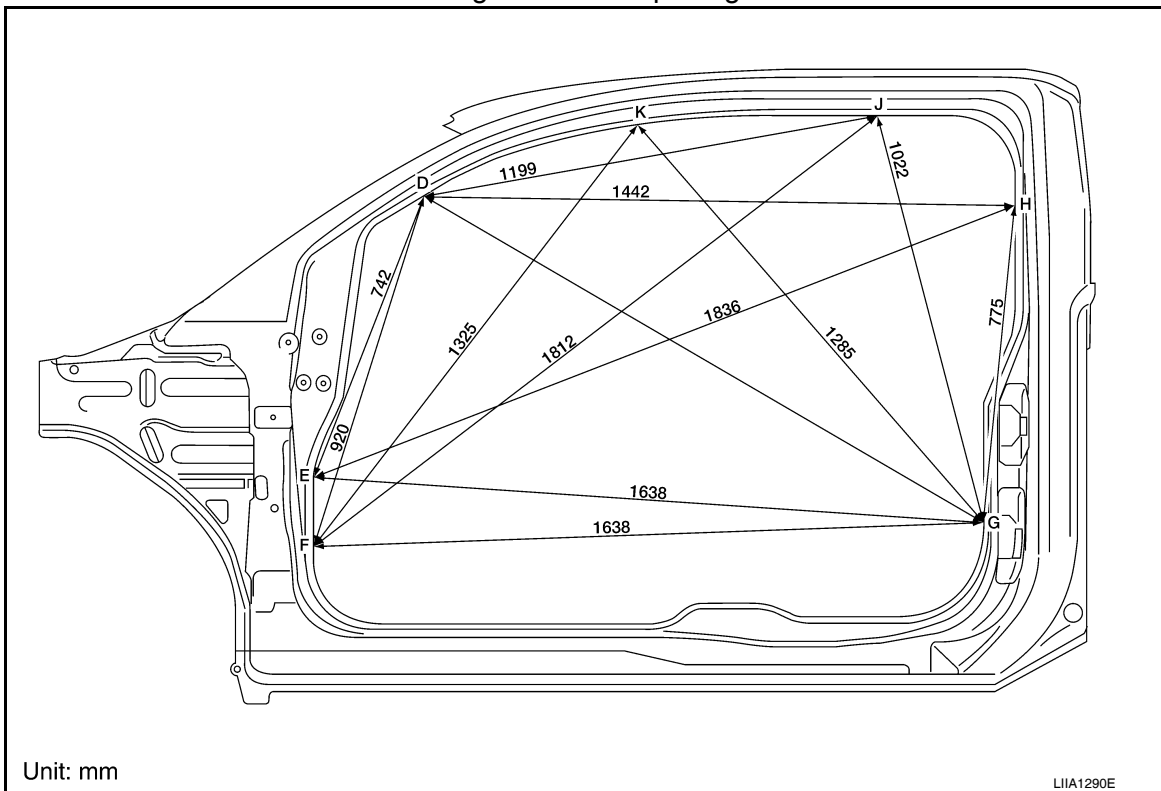

A
B
C
D
E
F
G
H
I
J
K
L
M
N
O
P

BRM

BODY ALIGNMENT

< UNIT REMOVAL AND INSTALLATION >

Crew Cab Door Opening

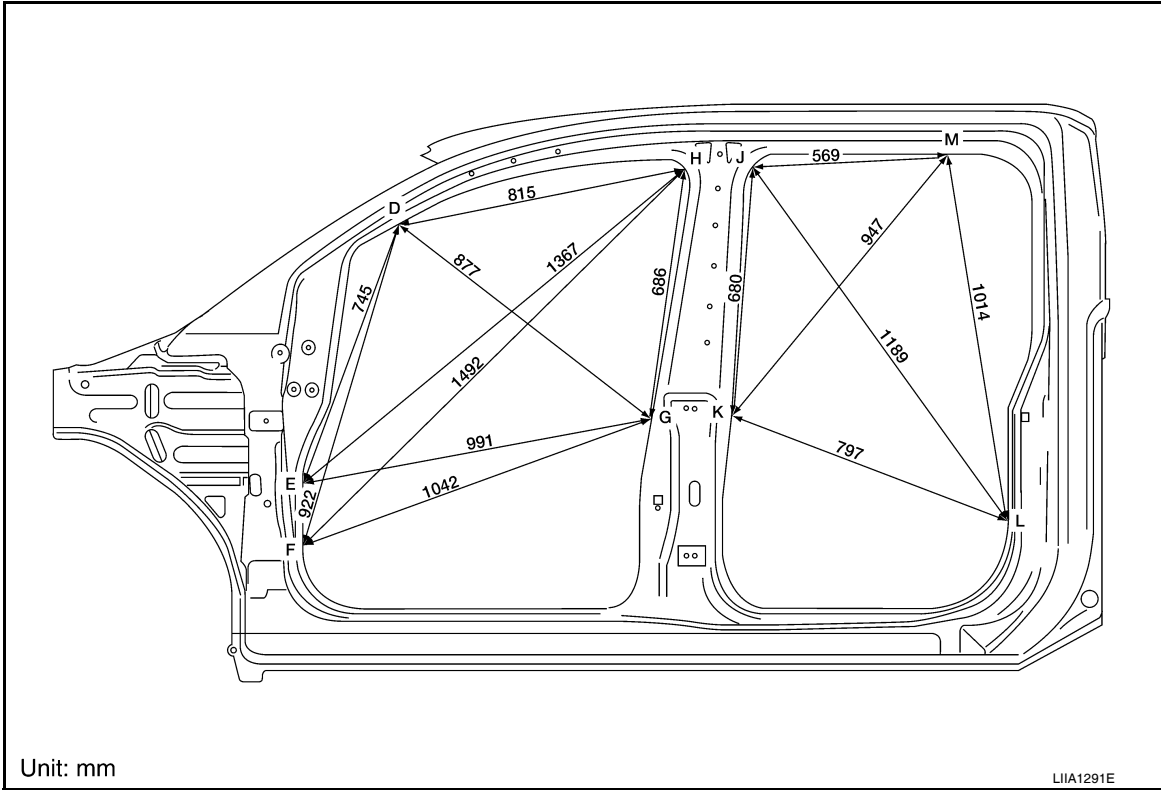

BODY ALIGNMENT

< UNIT REMOVAL AND INSTALLATION >

Rear Window Opening

Figures marked with a (*) indicate symmetrically identical dimensions on both right and left hand sides of the vehicle.

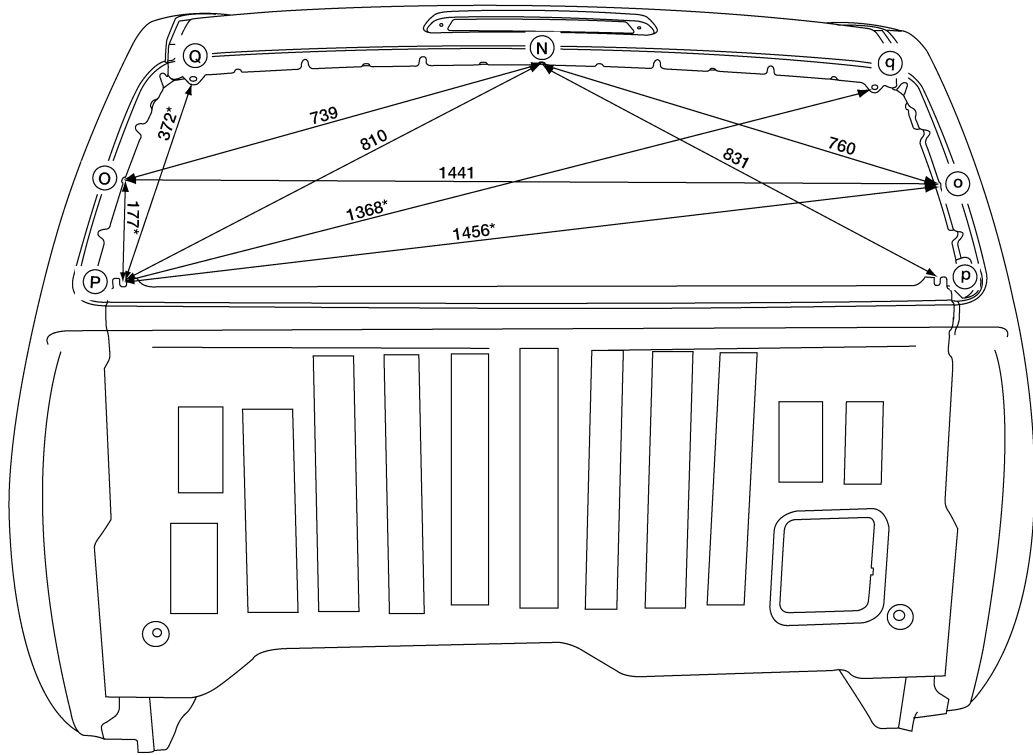

Unit: mm

ALKIA0497GB

A
B
C
D
E
F
G
H
I
J
K
L
M
N
O
P

BRM

BODY ALIGNMENT

< UNIT REMOVAL AND INSTALLATION >

MEASUREMENT POINTS

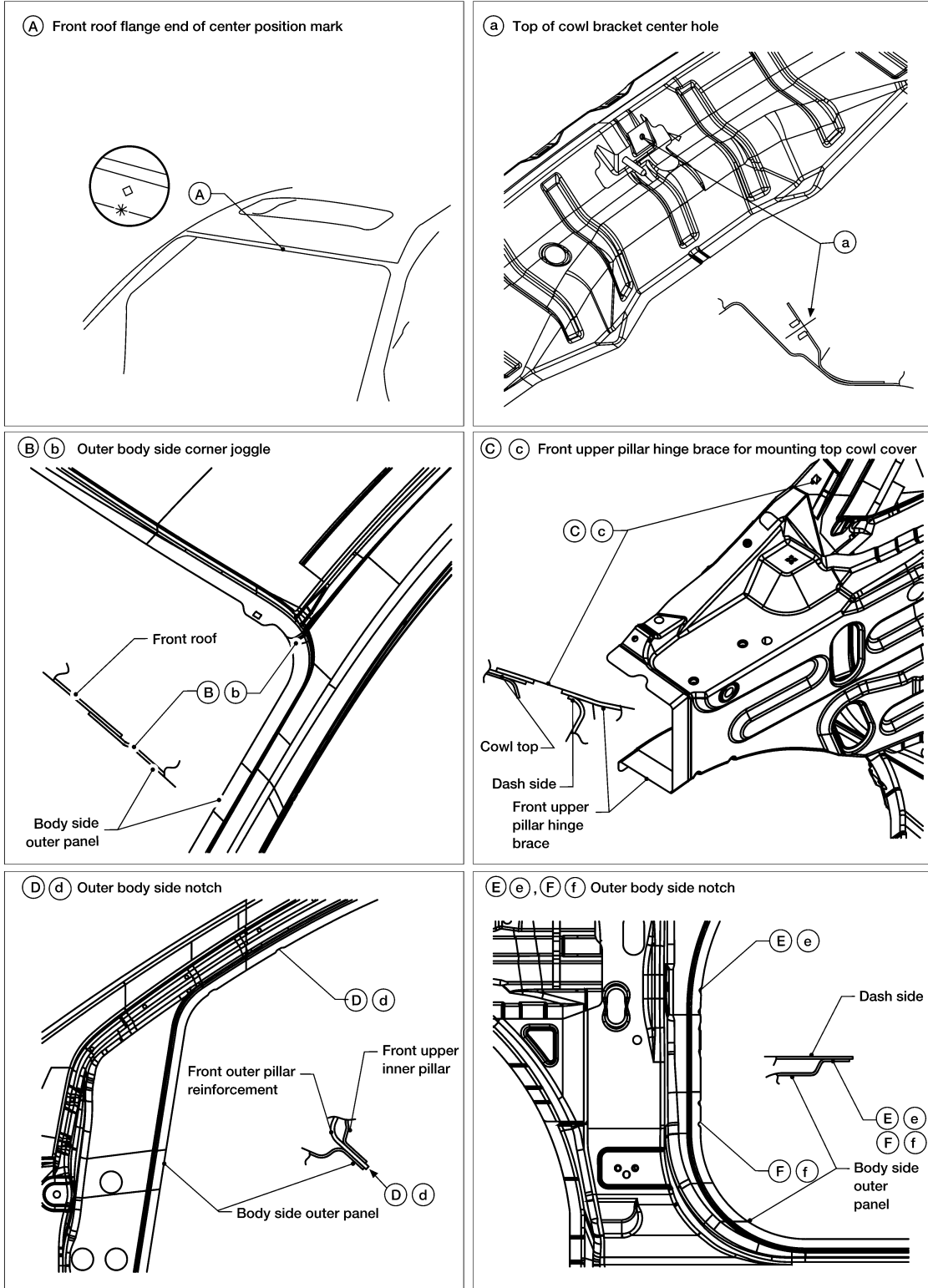

LIIA1300E

BODY ALIGNMENT

< UNIT REMOVAL AND INSTALLATION >

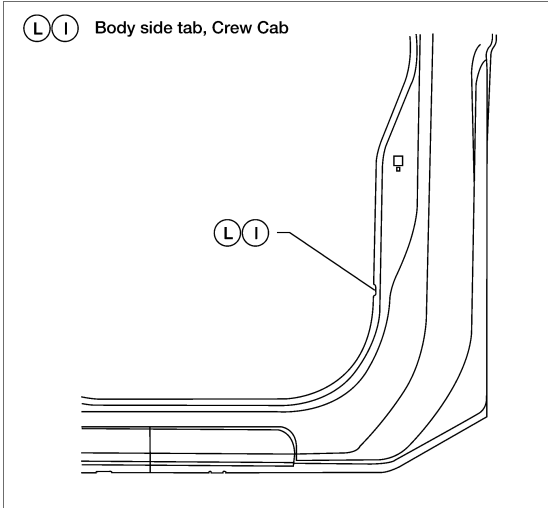
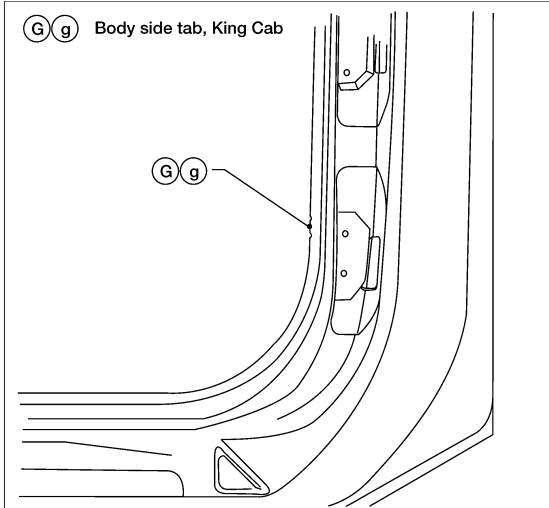
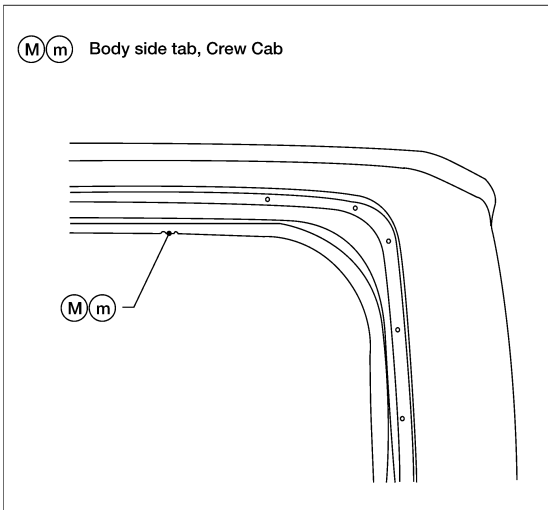
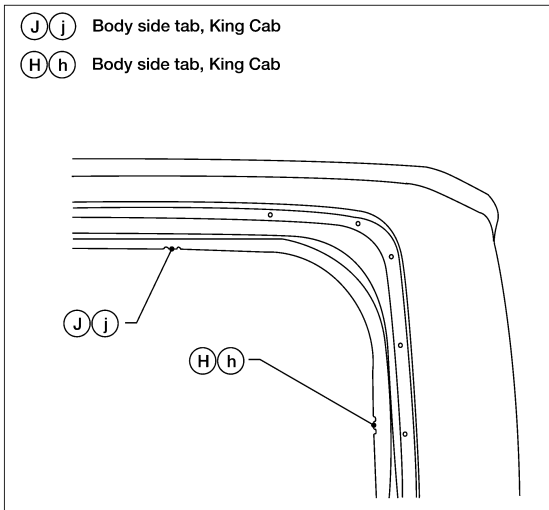
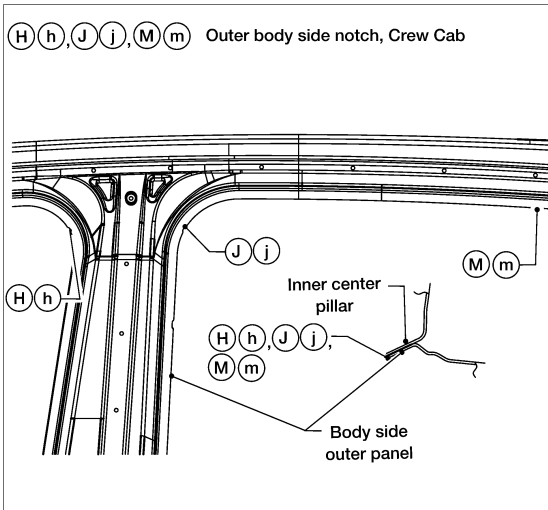
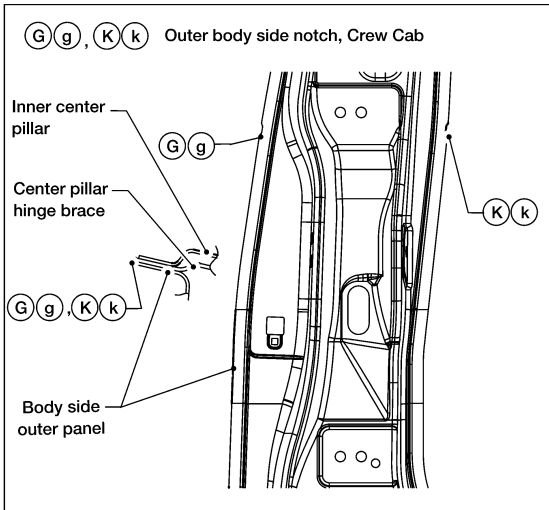

LIA1321E

A
B
C
D
E
F
G
H
I
J
BRM
L
M
N
O
P

BODY ALIGNMENT

< UNIT REMOVAL AND INSTALLATION >

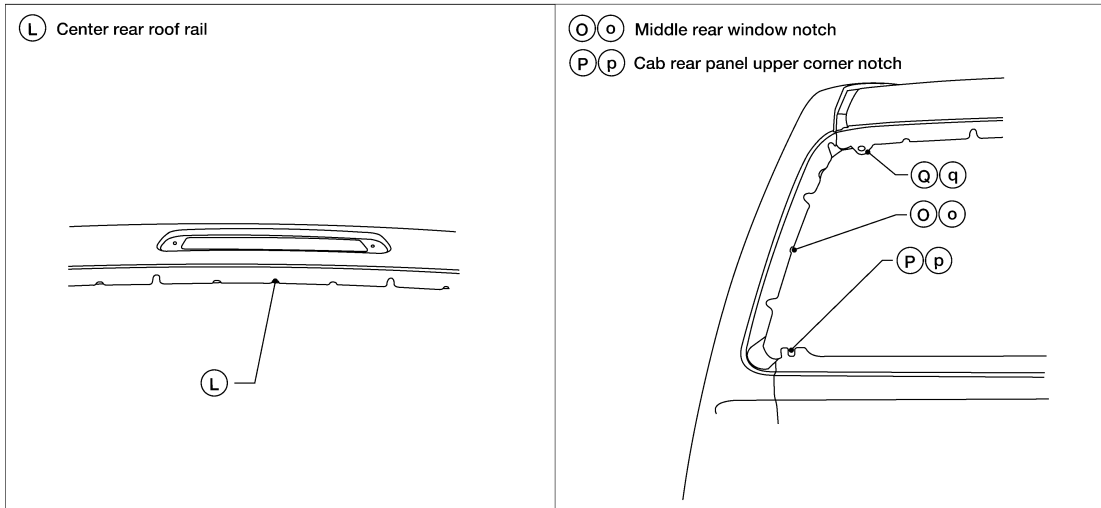

Rear Body

ALKIA0498GB

BODY ALIGNMENT

< UNIT REMOVAL AND INSTALLATION >

MEASUREMENT

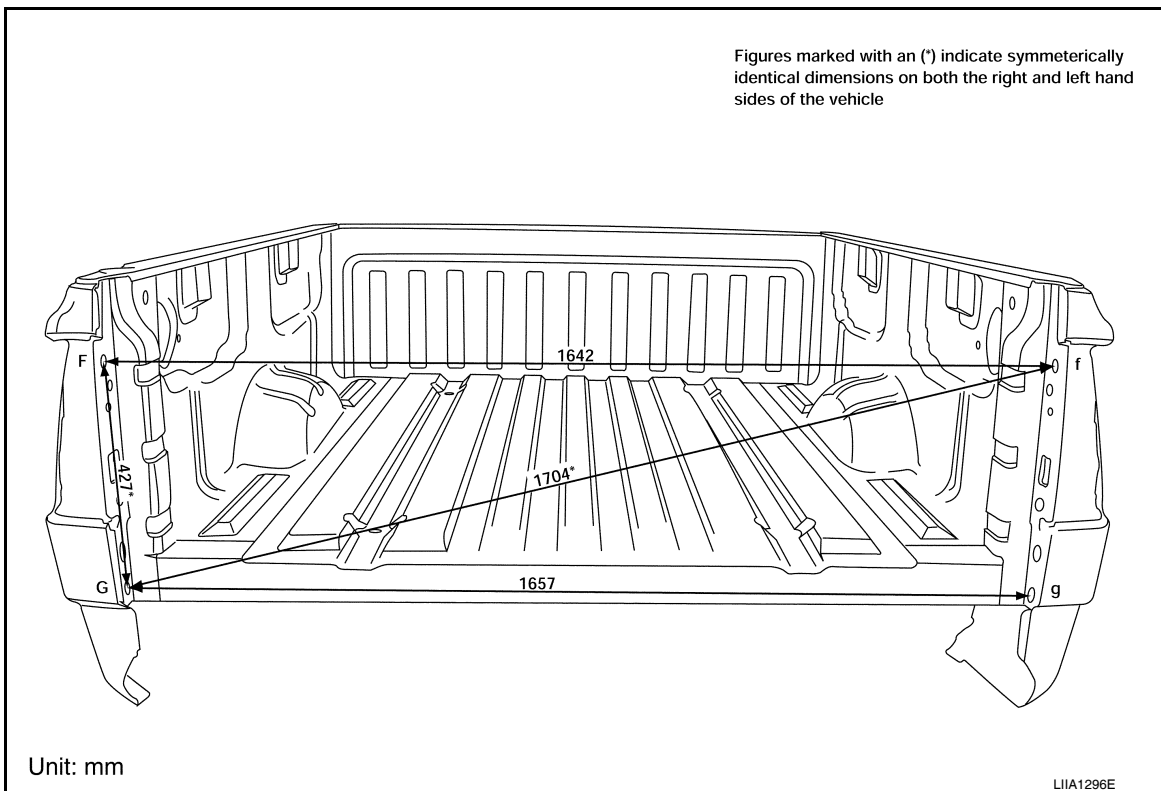
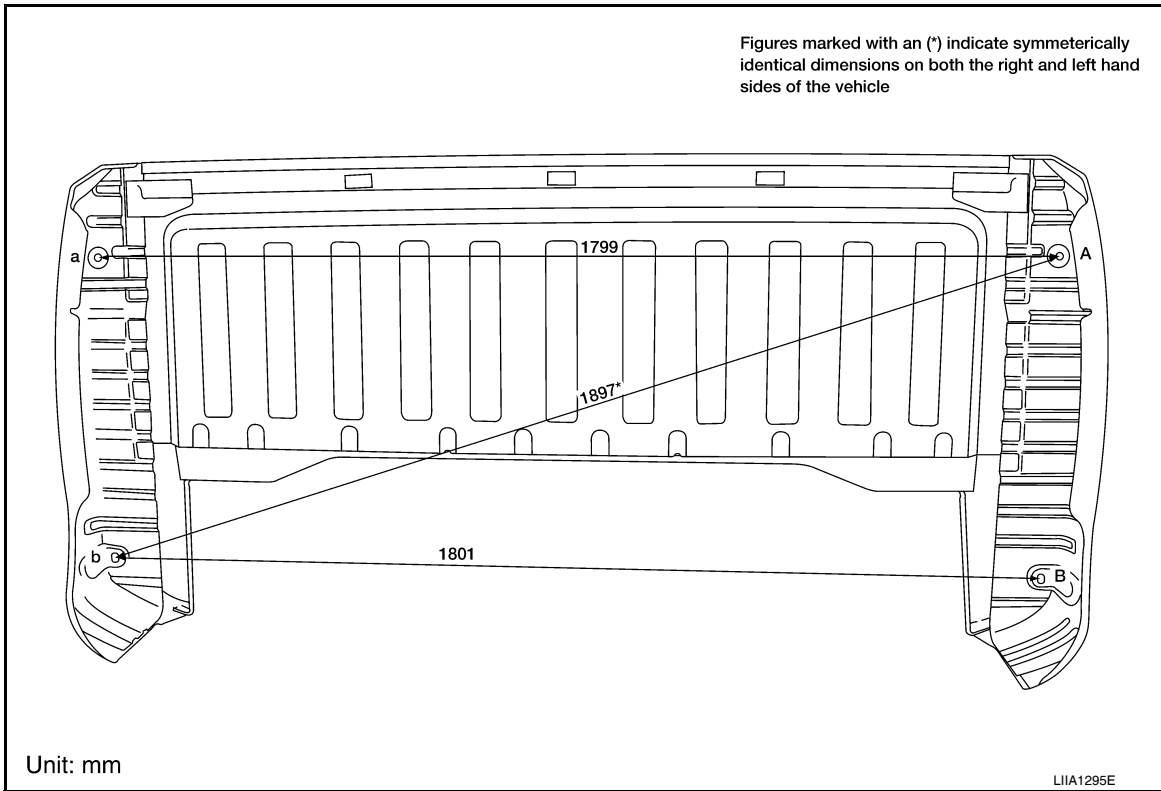

A
B
C
D
E
F
G
H
I
J
L
M
N
O
P

BRM

BODY ALIGNMENT

< UNIT REMOVAL AND INSTALLATION >

King Cab Bed Opening

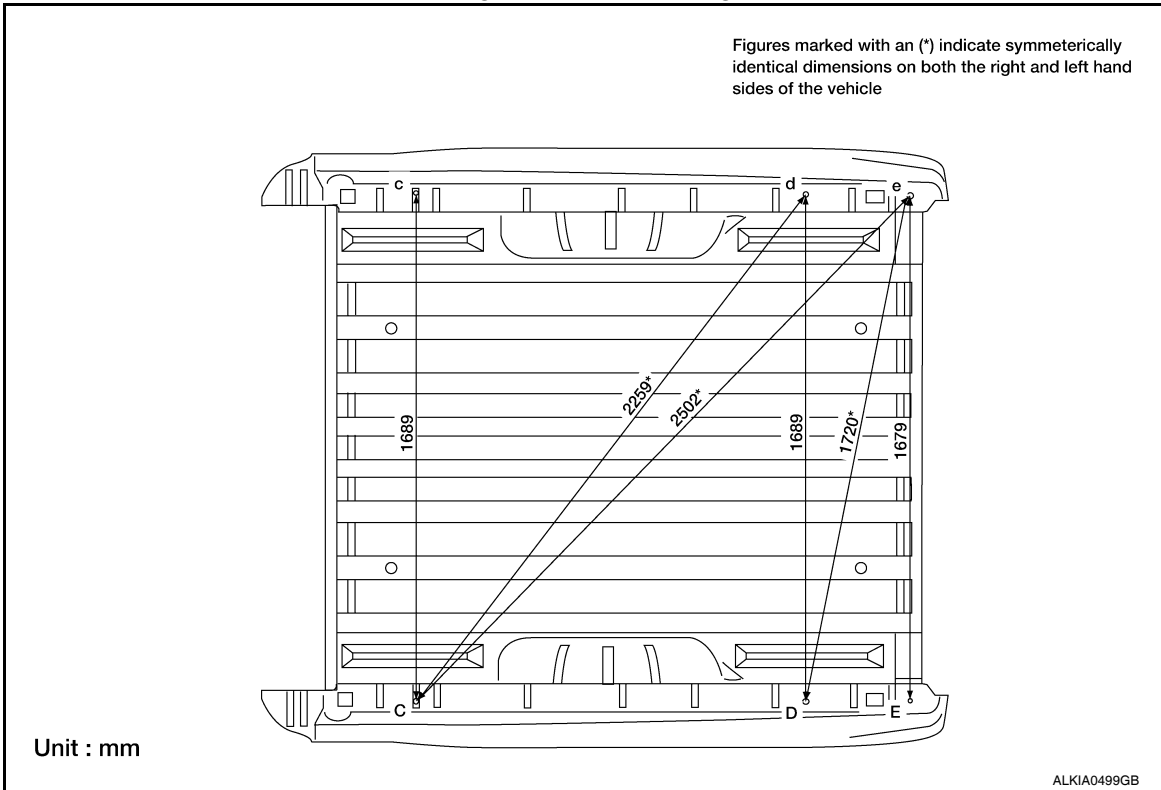

Crew Cab Bed Opening

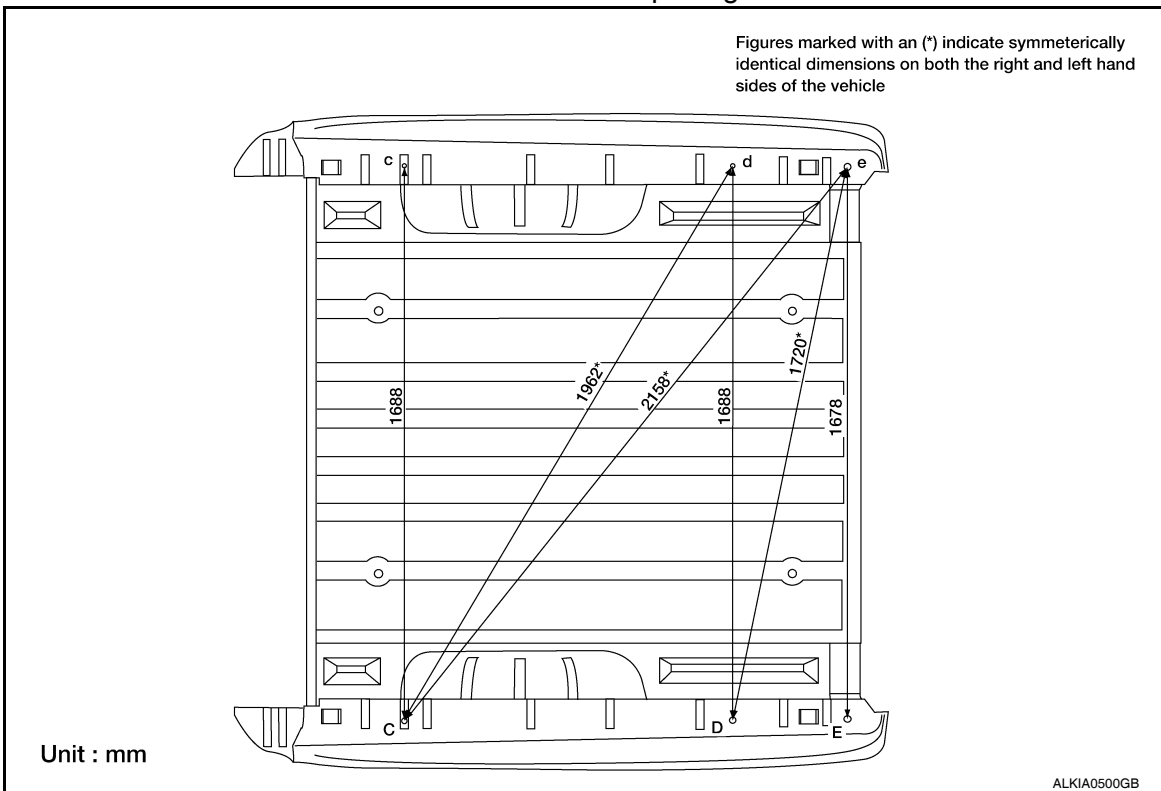

BODY ALIGNMENT

< UNIT REMOVAL AND INSTALLATION >

Long Bed Opening

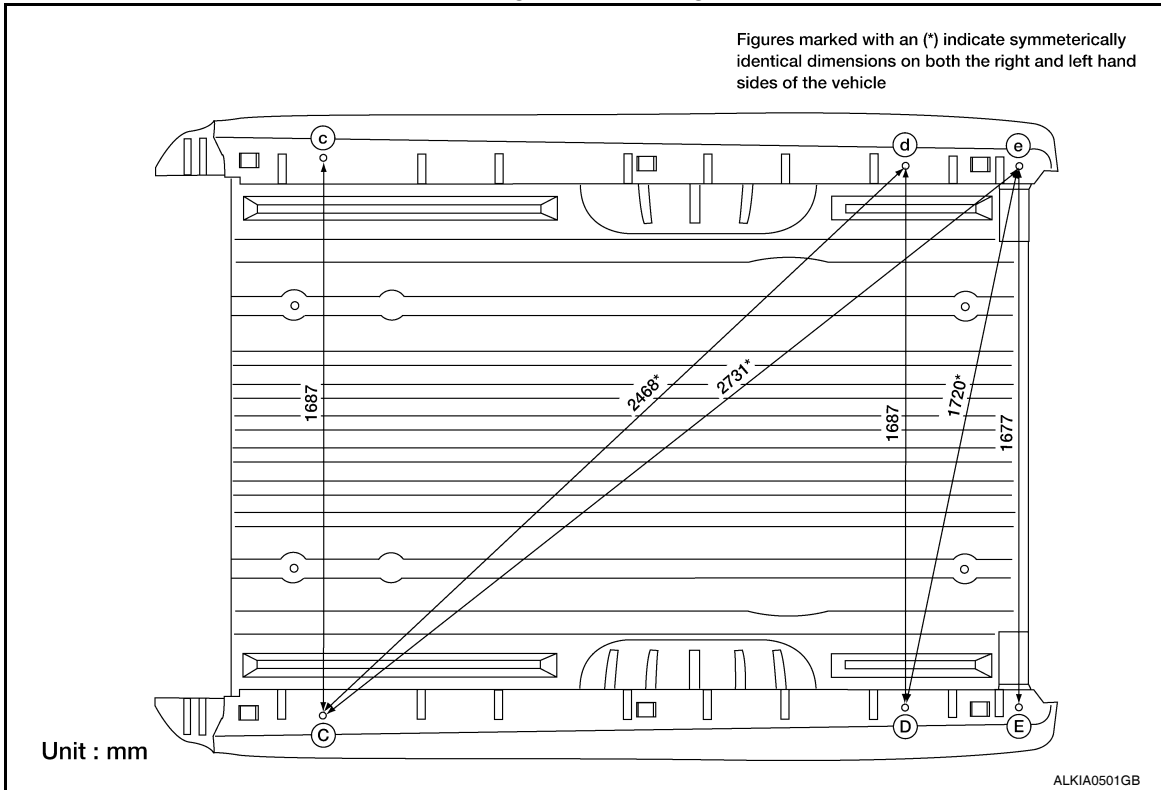

A
B
C
D
E
F
G
H
I
J
L
M
N
O
P

BRM

BODY ALIGNMENT

< UNIT REMOVAL AND INSTALLATION >

Measurement Points

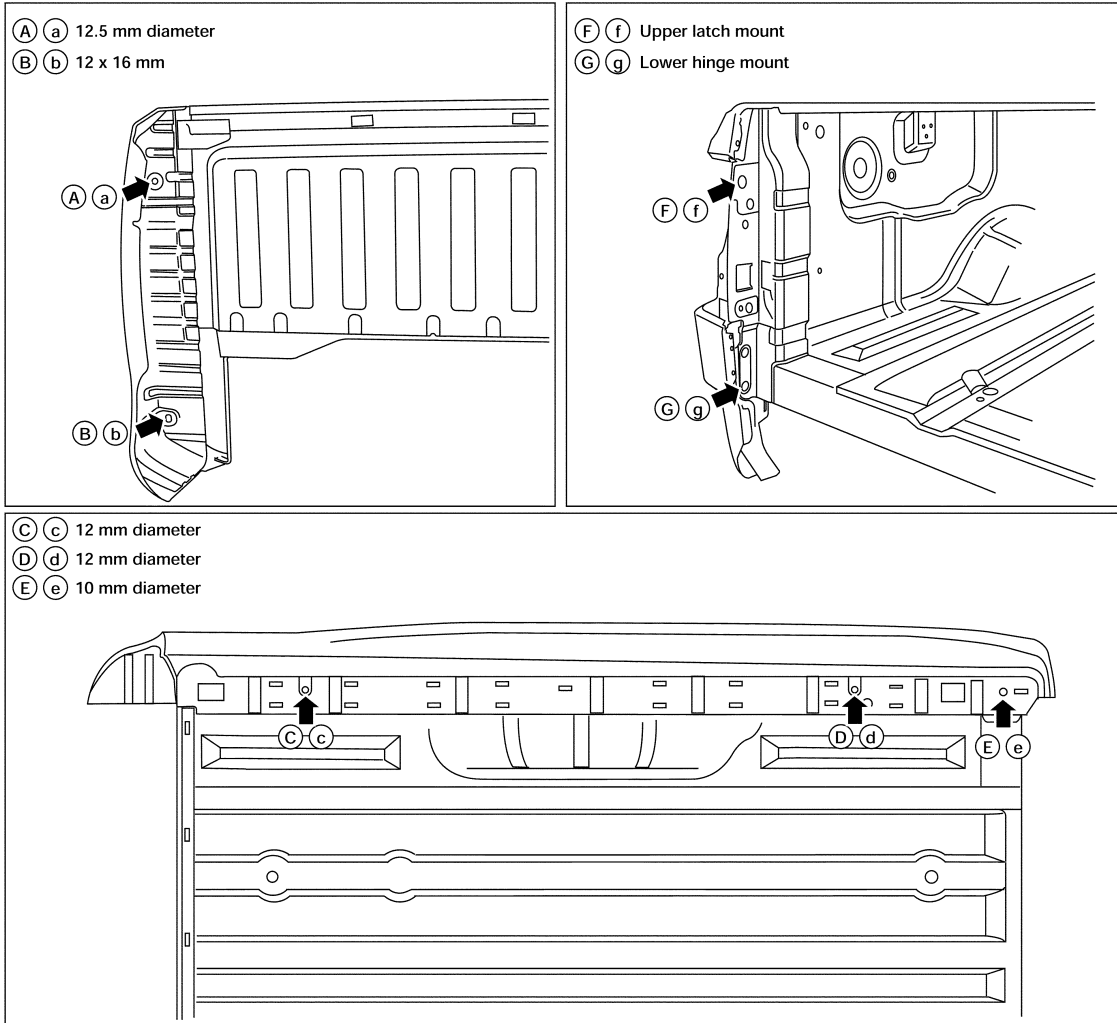

LIIA1334E

REPAIRING HIGH STRENGTH STEEL

< UNIT REMOVAL AND INSTALLATION >

REPAIRING HIGH STRENGTH STEEL

Precaution in Repairing High Strength Steel

INFOID:000000006158473

High strength steel is used for body panels in order to reduce vehicle weight.

Accordingly, precautions in repairing automotive bodies made of high strength steel are described below:

High strength steel (HSS) used in Nissan vehicles

Tensile strength	Nissan/Infiniti designation	Major applicable parts
373 N/mm ² (38kg/mm ² , 54klb/sq in)	SP130	<ul style="list-style-type: none"> • Front inner pillar upper • Front pillar hinge brace • Outer front pillar reinforcement • Other reinforcements
785-981 N/mm ² (80-100kg/mm ² 114-142klb/sq in)	SP150	<ul style="list-style-type: none"> • Outer sill reinforcement • Main back pillar

SP130 is the most commonly used HSS.

SP150 HSS is used only on parts that require much more strength.

Read the following precautions when repairing HSS:

1. Additional points to consider

- The repair of reinforcements (such as side members) by heating is not recommended since it may weaken the component. When heating is unavoidable, do not heat HSS parts above 550°C (1,022°F).

Verify heating temperature with a thermometer.

(Crayon-type and other similar type thermometer are appropriate.)

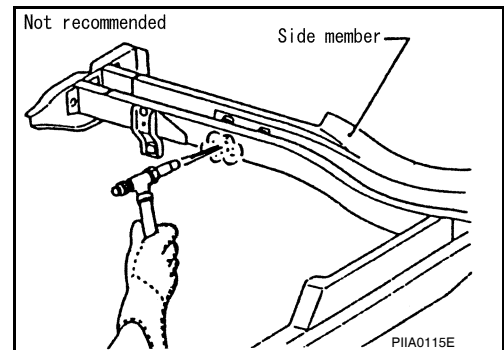

- When straightening body panels, use caution in pulling any HSS panel. Because HSS is very strong, pulling may cause deformation in adjacent portions of the body. In this case, increase the number of measuring points, and carefully pull the HSS panel.

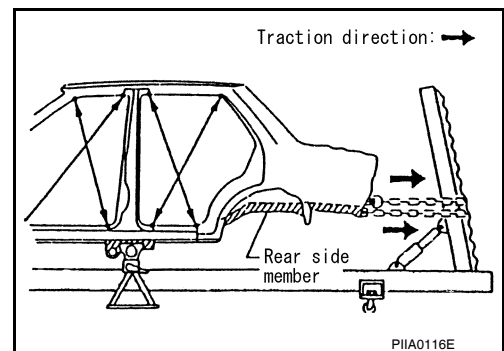

- When cutting HSS panels, avoid gas (torch) cutting if possible. Instead, use a saw to avoid weakening surrounding areas due to heat. If gas (torch) cutting is unavoidable, allow a minimum margin of 50 mm (1.97in).

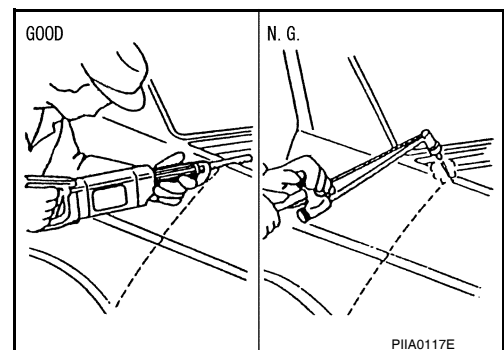

A
B
C
D
E
F
G
H
I
J
BRM
L
M
N
O
P

REPAIRING HIGH STRENGTH STEEL

< UNIT REMOVAL AND INSTALLATION >

- When welding HSS panels, use spot welding whenever possible in order to minimize weakening surrounding areas due to heat. If spot welding is impossible, use M.I.G. welding. Do not use gas (torch) welding because it is inferior in welding strength.

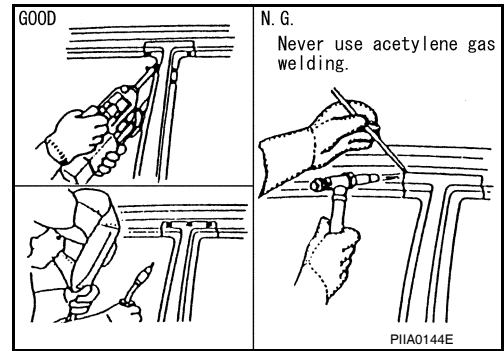

- The spot weld on HSS panels is harder than that of an ordinary steel panel. Therefore, when cutting spot welds on a HSS panel, use a low speed high torque drill (1,000 to 1,200 rpm) to increase drill bit durability and facilitate the operation.
- SP150 HSS panels with a tensile strength of 785 to 981 N/mm² (80 to 100 kg/mm², 114 to 142 klb/sq in), used as reinforcement in the door guard beams, is too strong to repair. When these HSS parts are damaged, the outer panels also sustain substantial damage; therefore, the assembly parts must be replaced.

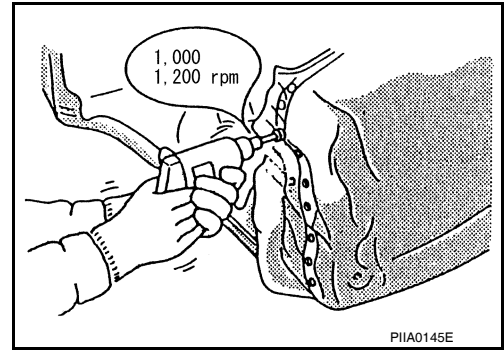

2. Precautions in spot welding HSS

This work should be performed under standard working conditions. Always note the following when spot welding HSS:

- The electrode tip diameter must be sized properly according to the metal thickness.

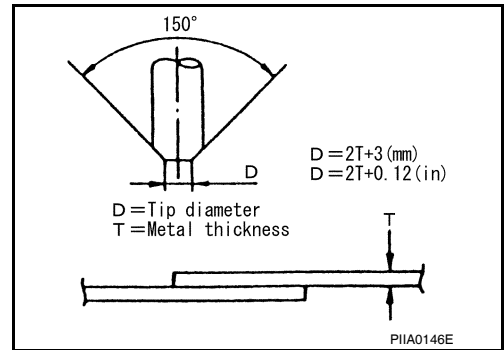

- The panel surfaces must fit flush to each other, leaving no gaps.

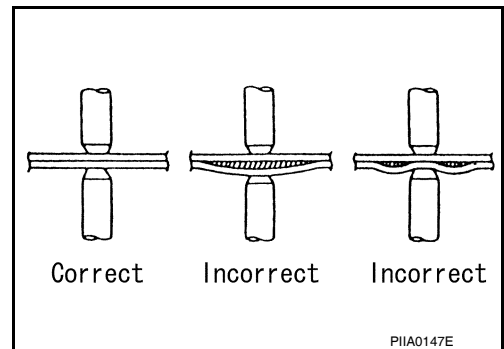

REPAIRING HIGH STRENGTH STEEL

< UNIT REMOVAL AND INSTALLATION >

- Follow the specifications for the proper welding pitch.

Thickness (t)	Minimum pitch (ℓ)
0.6 (0.024)	10 (0.39) or over
0.8 (0.031)	12 (0.47) or over
1.0 (0.039)	18 (0.71) or over
1.2 (0.047)	20 (0.79) or over
1.6 (0.063)	27 (1.06) or over
1.8 (0.071)	31 (1.22) or over

Unit:mm

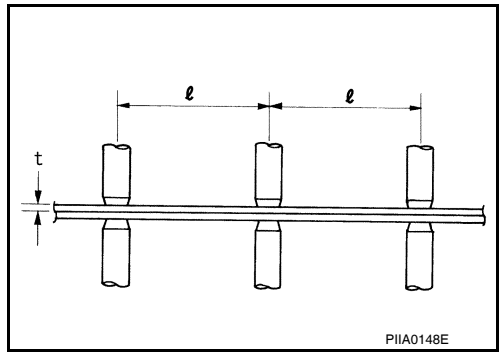

A
B
C
D
E
F
G
H
I
J
L
M
N
O
P

BRM

REPLACEMENT OPERATIONS

< UNIT REMOVAL AND INSTALLATION >

REPLACEMENT OPERATIONS

Replacement Operation

INFOID:000000006158474

DESCRIPTION

This section is prepared for technicians who have attained a high level of skill and experience in repairing collision-damaged vehicles and also use modern service tools and equipment. Persons unfamiliar with body repair techniques should not attempt to repair collision-damaged vehicles by using this section.









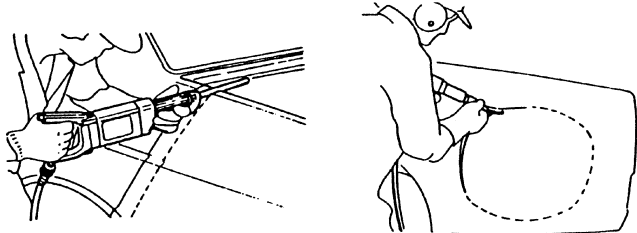

Technicians are also encouraged to read Body Repair Manual (Fundamentals) in order to ensure that the original functions and quality of the vehicle can be maintained. The Body Repair Manual (Fundamentals) contains additional information, including cautions and warnings, that are not including in this manual. Technicians should refer to both manuals to ensure proper repairs.

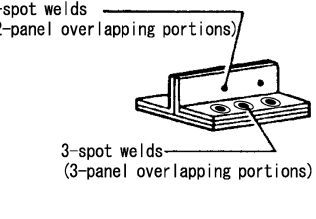
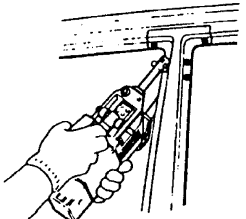
Please note that this information is prepared for worldwide usage, and as such, certain procedures may not apply in some regions or countries.

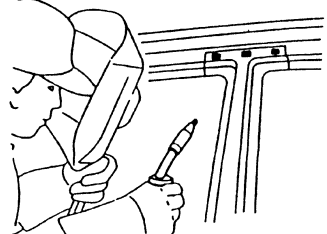
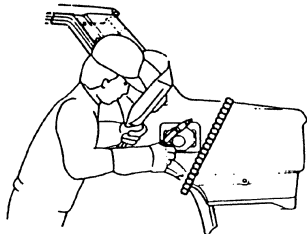
REPLACEMENT OPERATIONS

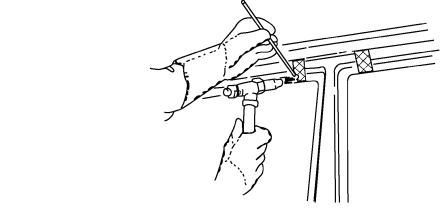
< UNIT REMOVAL AND INSTALLATION >

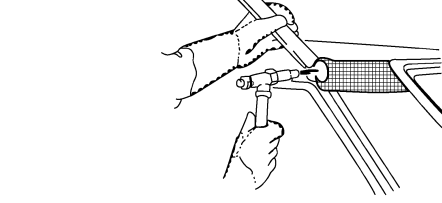
The symbols used in this section for cutting and welding / brazing operations are shown below.

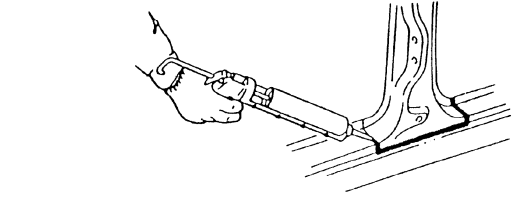
 Saw cut or air chisel cut		
Spot weld  2-spot welds  3-spot welds	 2-spot welds (2-panel overlapping portions) 3-spot welds (3-panel overlapping portions)	
MIG plug weld  MIG seam weld/ Point weld 		
Brazing 		
Soldering 		
Sealing 		

A
B
C
D
E
F
G
H
I
J
BRM
L
M
N
O
P

PIIA0149E

REPLACEMENT OPERATIONS

< UNIT REMOVAL AND INSTALLATION >

- Front pillar butt joint can be determined anywhere within shaded area as shown in the figure. The best location for the butt joint is at position A due to the construction of the vehicle. Refer to the front pillar section.

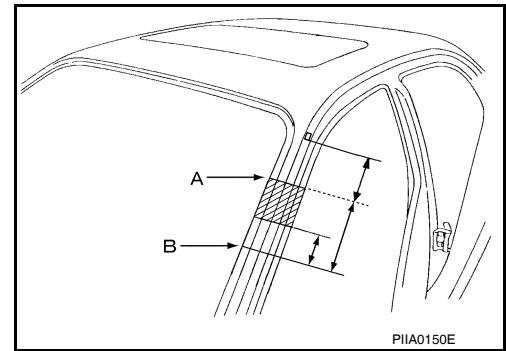

- Determine cutting position and record distance from the locating indent. Use this distance when cutting the service part. Cut outer front pillar over 60 mm above inner front pillar cut position.

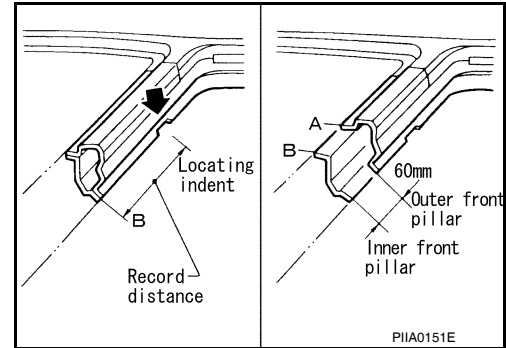

- Prepare a cutting jig to make outer pillar easier to cut. Also, this will permit service part to be accurately cut at joint position.

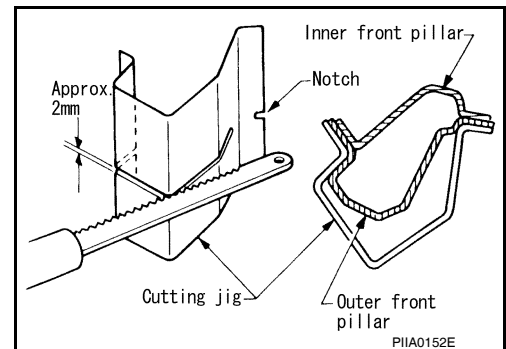

- An example of cutting operation using a cutting jig is as follows.

1. Mark cutting lines.
A: Cut position of outer pillar
B: Cut position of inner pillar
2. Align cutting line with notch on jig. Clamp jig to pillar.
3. Cut outer pillar along groove of jig. (At position A)
4. Remove jig and cut remaining portions.
5. Cut inner pillar at position B in same manner.

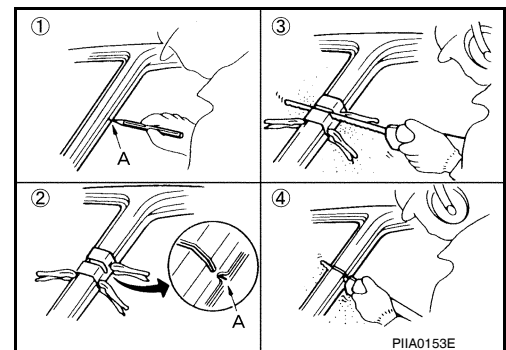

HOODLEDGE

- Work after radiator core support has been removed.

REPLACEMENT OPERATIONS

< UNIT REMOVAL AND INSTALLATION >

Service Joint

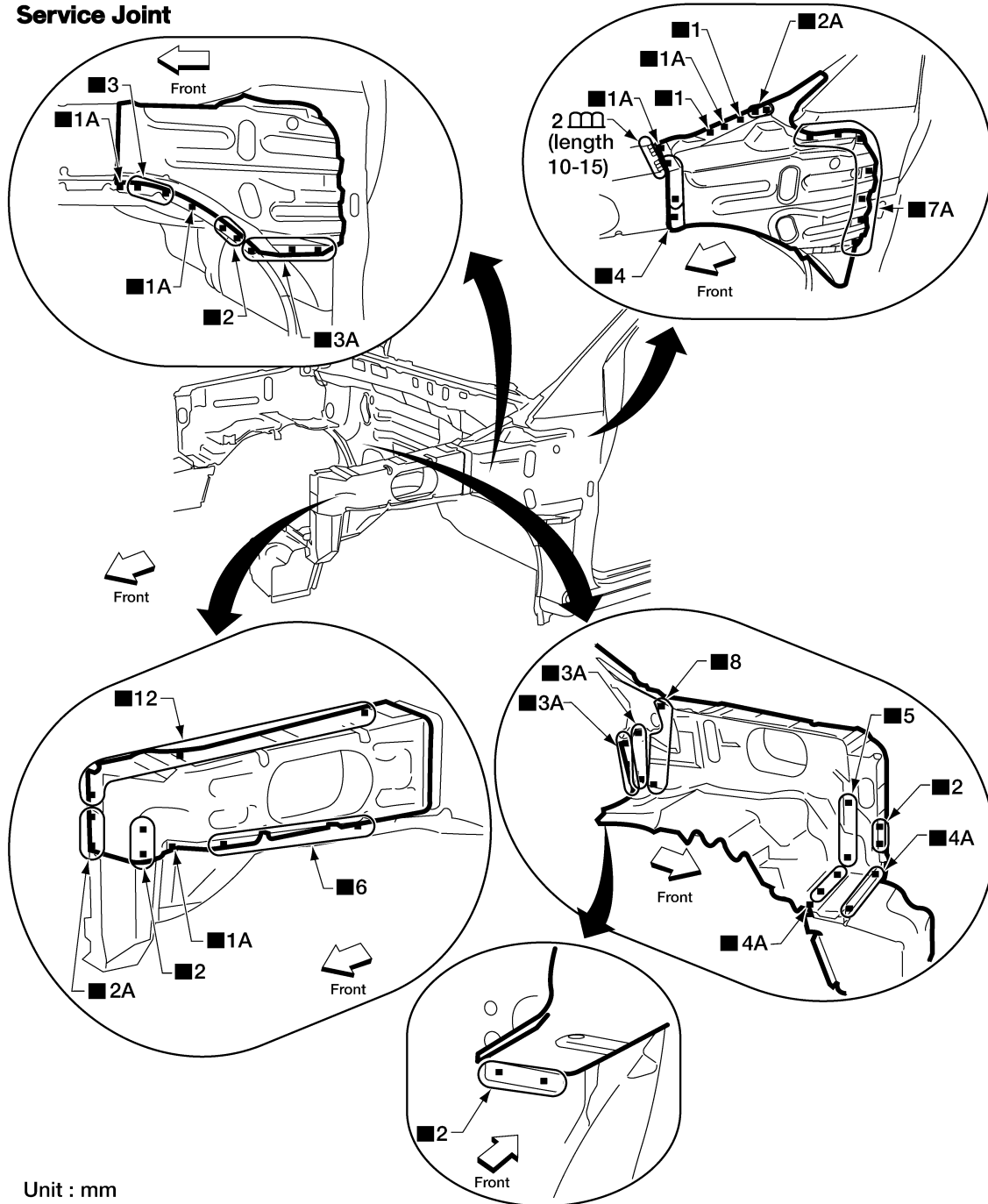

Unit : mm

2-spot welds

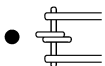

3-spot welds



MIG Plug weld

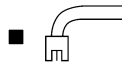

(For 3 panels plug weld method)

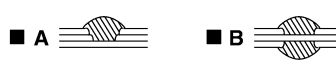

MIG seam weld/
Point weld



ALKIA0517GB

Change parts:

- Hoodledge reinforcement
- Battery mounting reinforcement (RH)
- Hoodledge front reinforcement
- Harness bracket (RH)
- 1st body mounting bracket (LH)
- Rear hoodledge reinforcement

FRONT PILLAR

Work after rear hoodledge reinforcement has been removed.

A
B
C
D
E
F
G
H
I
J
K
L
M
N
O
P

BRM

REPLACEMENT OPERATIONS

< UNIT REMOVAL AND INSTALLATION >

Front Pillar Outer

Service Joint

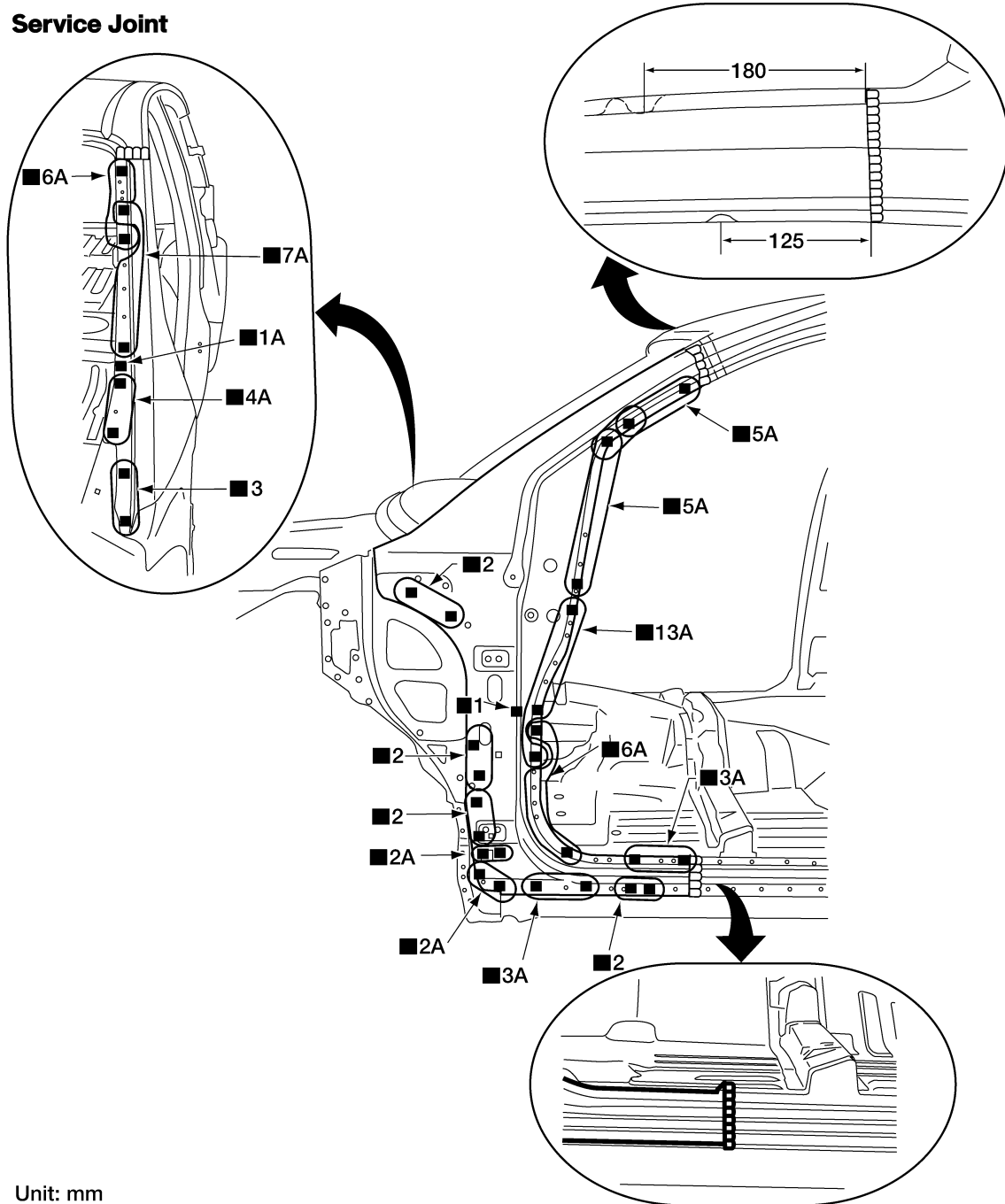

Unit: mm

2-spot welds

3-spot welds

MIG Plug weld

For 3 panels plug weld method

MIG seam weld/
Point weld



ALKIA0516GB

Change parts:

- Front pillar portion of body side outer

REPLACEMENT OPERATIONS

< UNIT REMOVAL AND INSTALLATION >

Front Pillar Brace

Service Joint

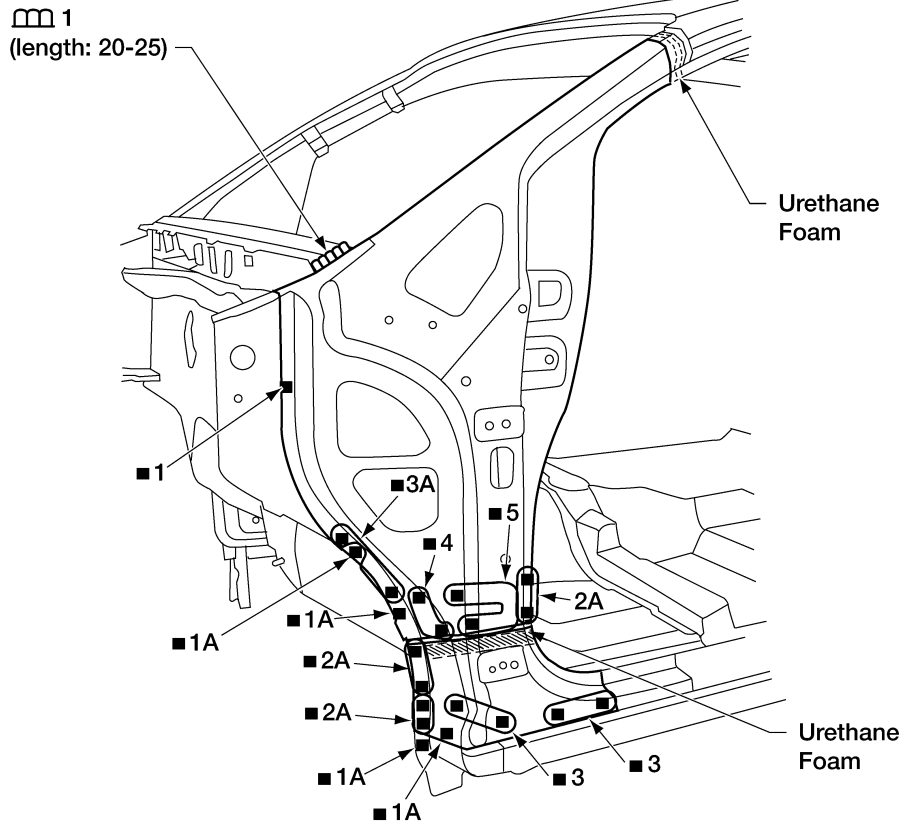

Unit : mm

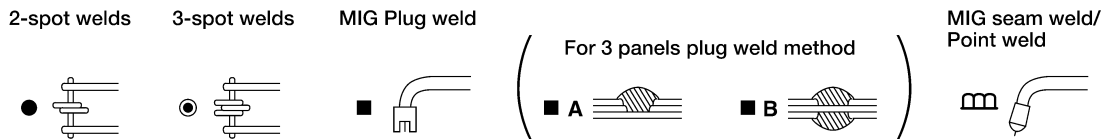

ALKIA0515GB

Change parts:

- Front pillar brace

A
B
C
D
E
F
G
H
I
J
K
L
M
N
O
P

BRM

REPLACEMENT OPERATIONS

< UNIT REMOVAL AND INSTALLATION >

Inner Upper Front Pillar

Service Joint

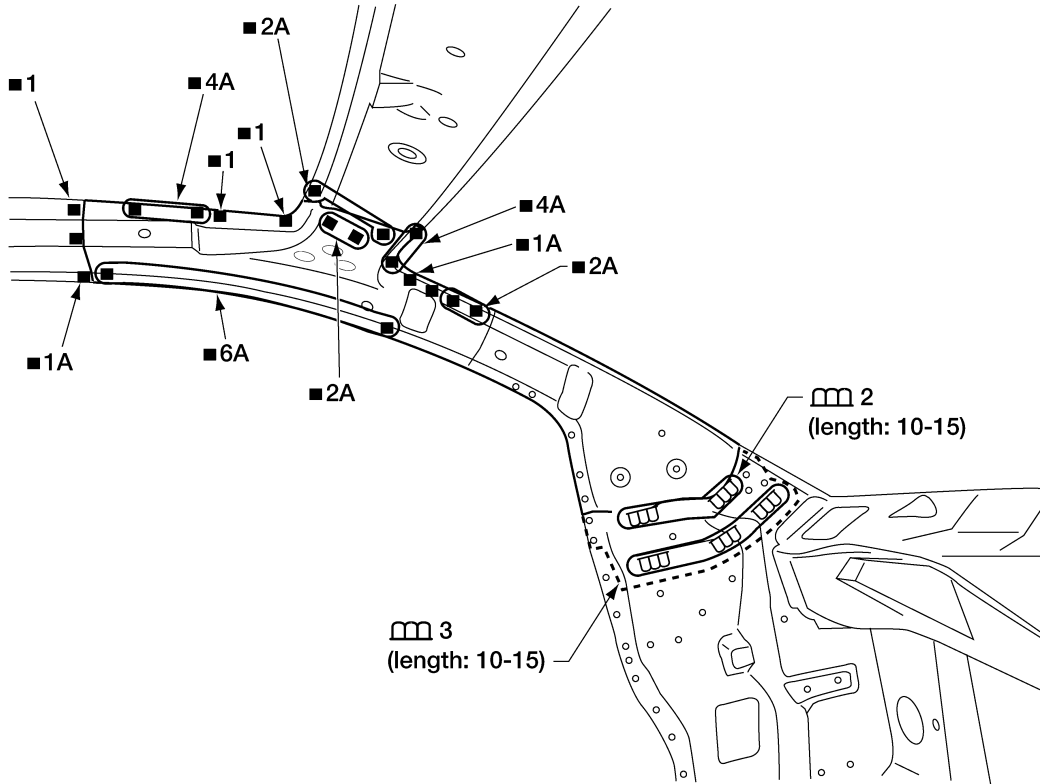

Unit : mm

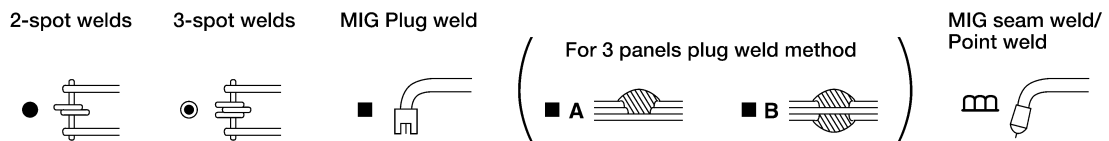

ALKIA0514GB

Change parts:

- Inner upper front pillar

DASH SIDE

Work with front pillar brace and outer sill reinforcement removed.

REPLACEMENT OPERATIONS

< UNIT REMOVAL AND INSTALLATION >

Service Joint

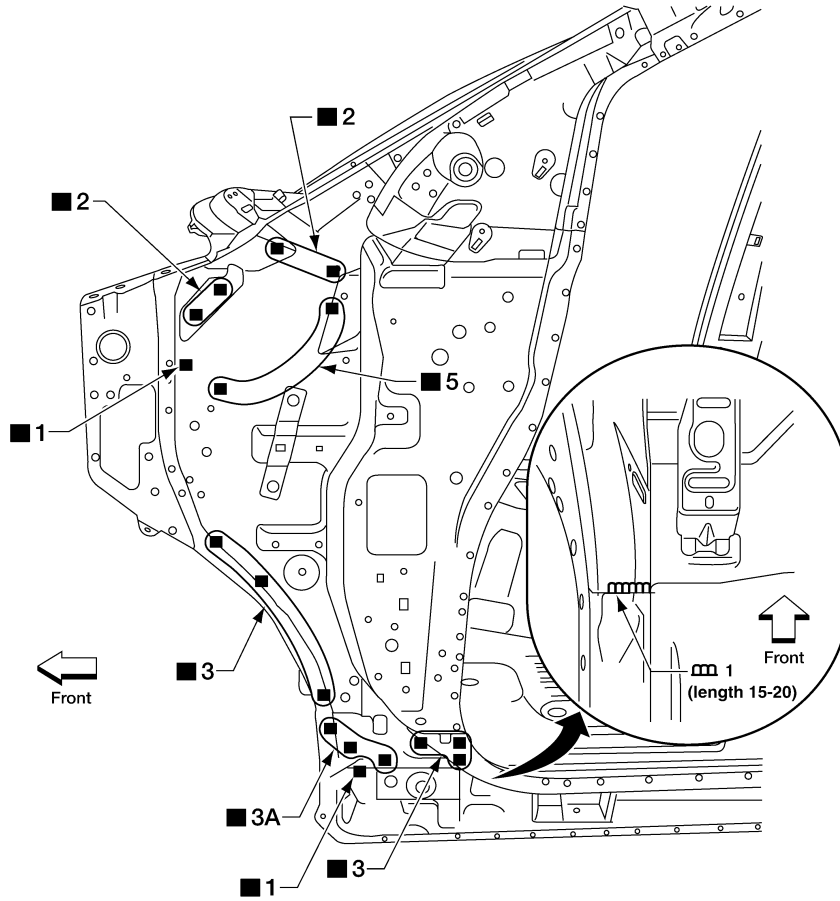

A
B
C
D
E
F
G
H
I
J

BRM

L
M
N
O
P

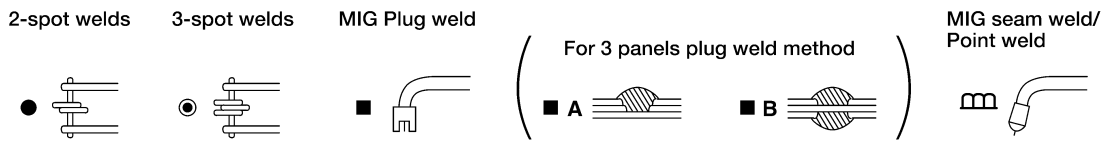

ALKIA0536GB

Change parts:
● Dash side

CENTER PILLAR

REPLACEMENT OPERATIONS

< UNIT REMOVAL AND INSTALLATION >

Center Pillar Outer

Service Joint

* Reinforcement is retained with the same welds as the center-pillar outer sheet metal.

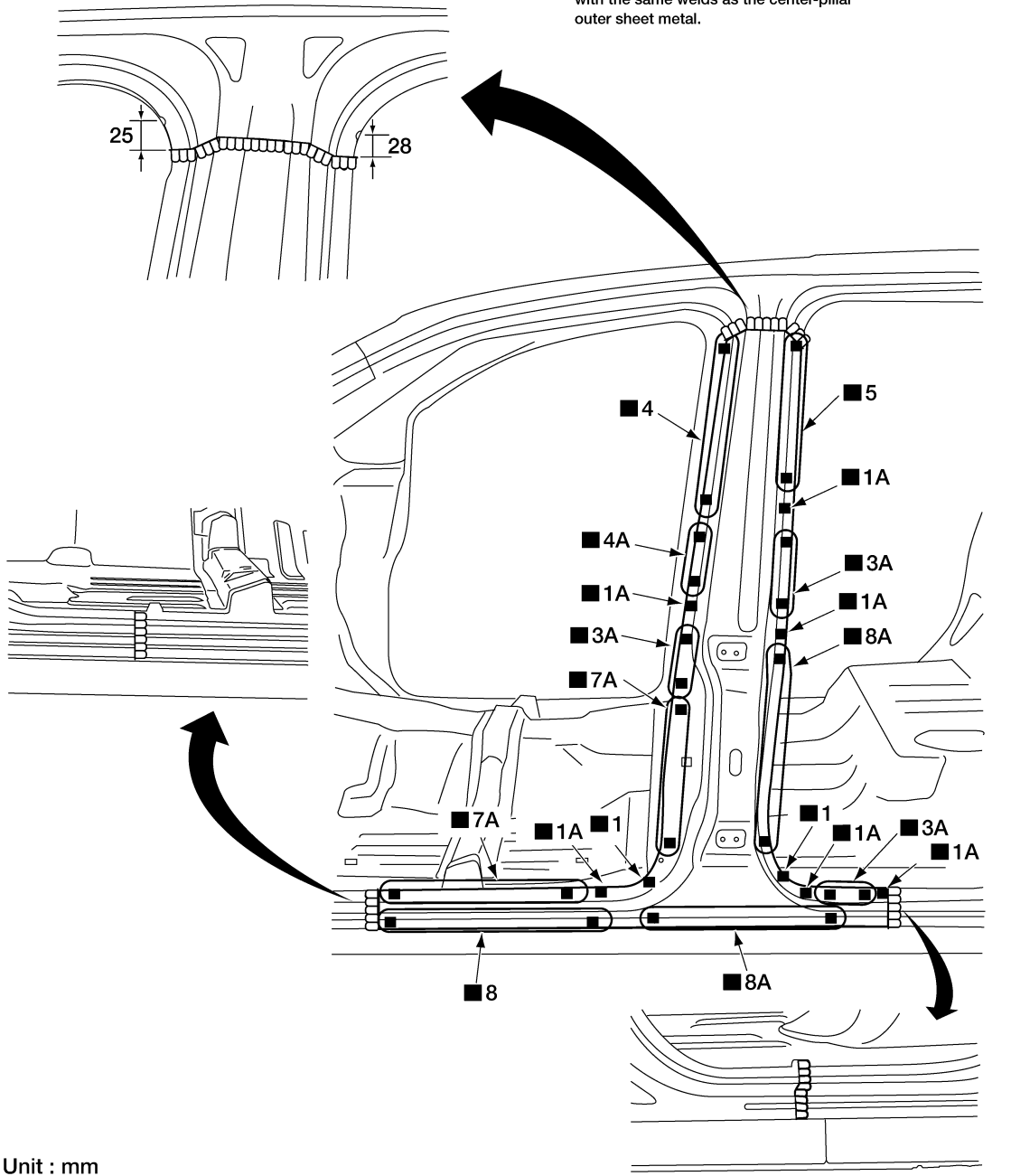

Unit : mm

2-spot welds

3-spot welds

MIG Plug weld

For 3 panels plug weld method

MIG seam weld/
Point weld



ALKIA0513GB

Change parts:

- Center pillar portion of body side outer (Crew Cab only)

REPLACEMENT OPERATIONS

< UNIT REMOVAL AND INSTALLATION >

Inner Center Pillar

Service Joint

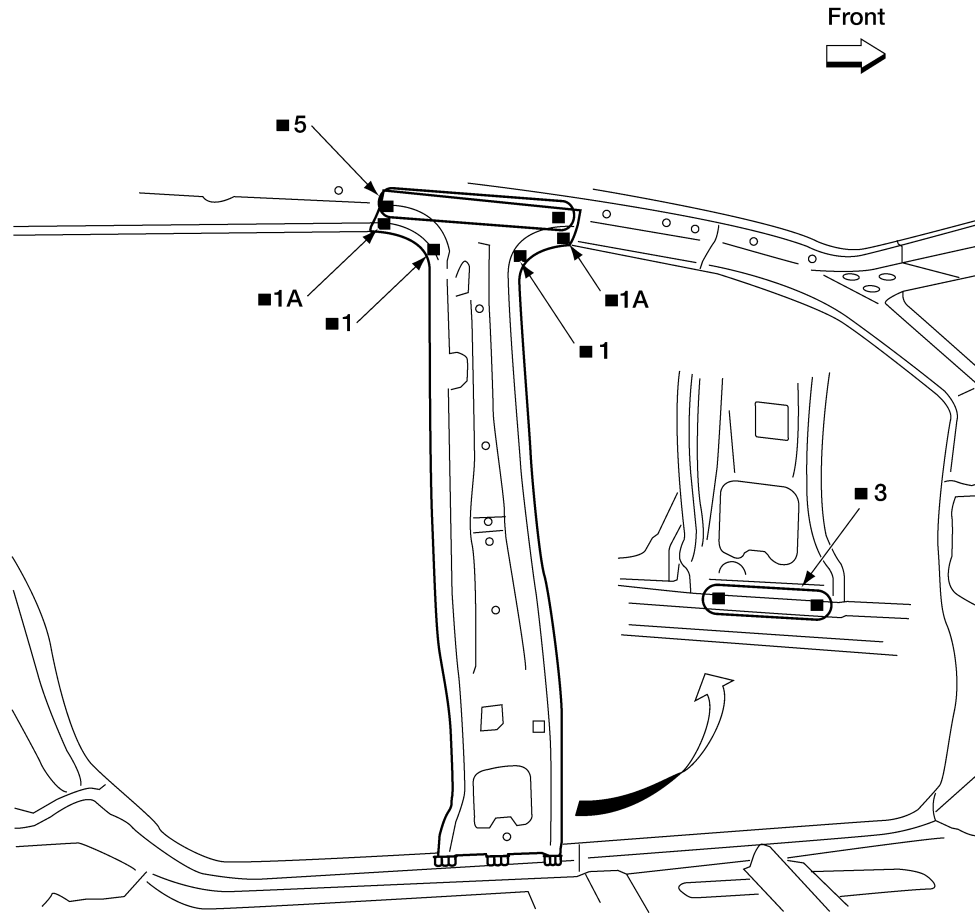

A
B
C
D
E
F
G
H
I
J

BRM

L
M
N
O
P

Unit : mm

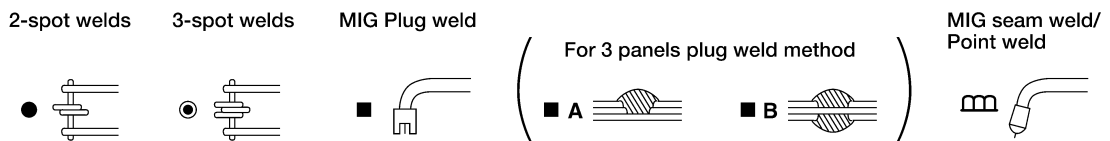

ALKIA0512GB

Change parts:

- Inner center pillar (Crew Cab only)

OUTER SILL

Work with front pillar brace, rear cab pillar and center pillar inner (if equipped) removed.

KING CAB

REPLACEMENT OPERATIONS

< UNIT REMOVAL AND INSTALLATION >

Center Sill Portion of Body Side Outer

Service Joint

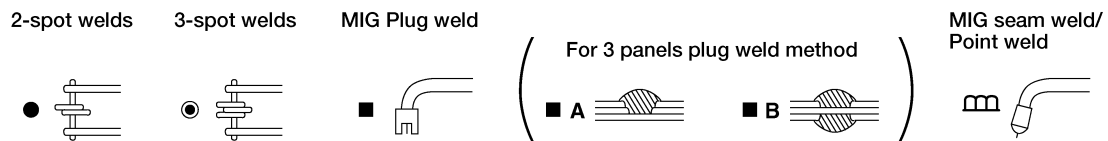
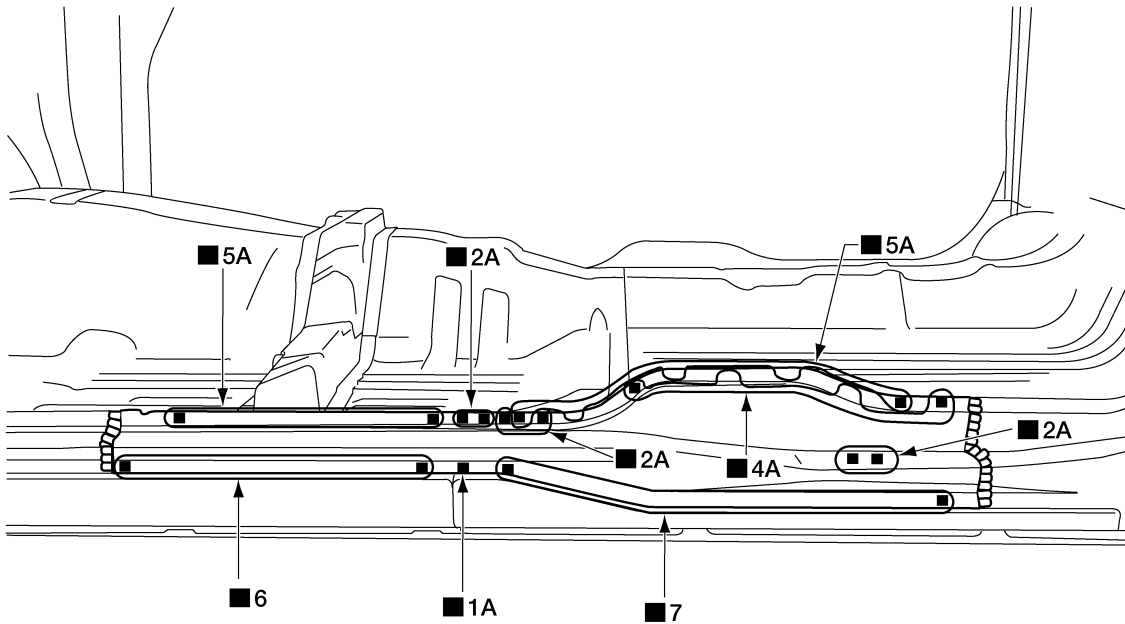

WIA0344E

Change parts:

- Center sill portion of body side outer

Work with front pillar outer, rear pillar outer, and center sill portion of body side outer removed.

REPLACEMENT OPERATIONS

< UNIT REMOVAL AND INSTALLATION >

Outer Sill Reinforcement

Service Joint

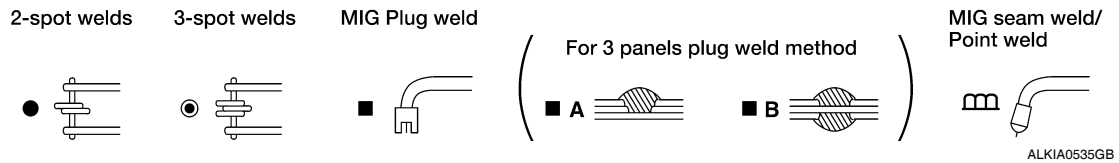
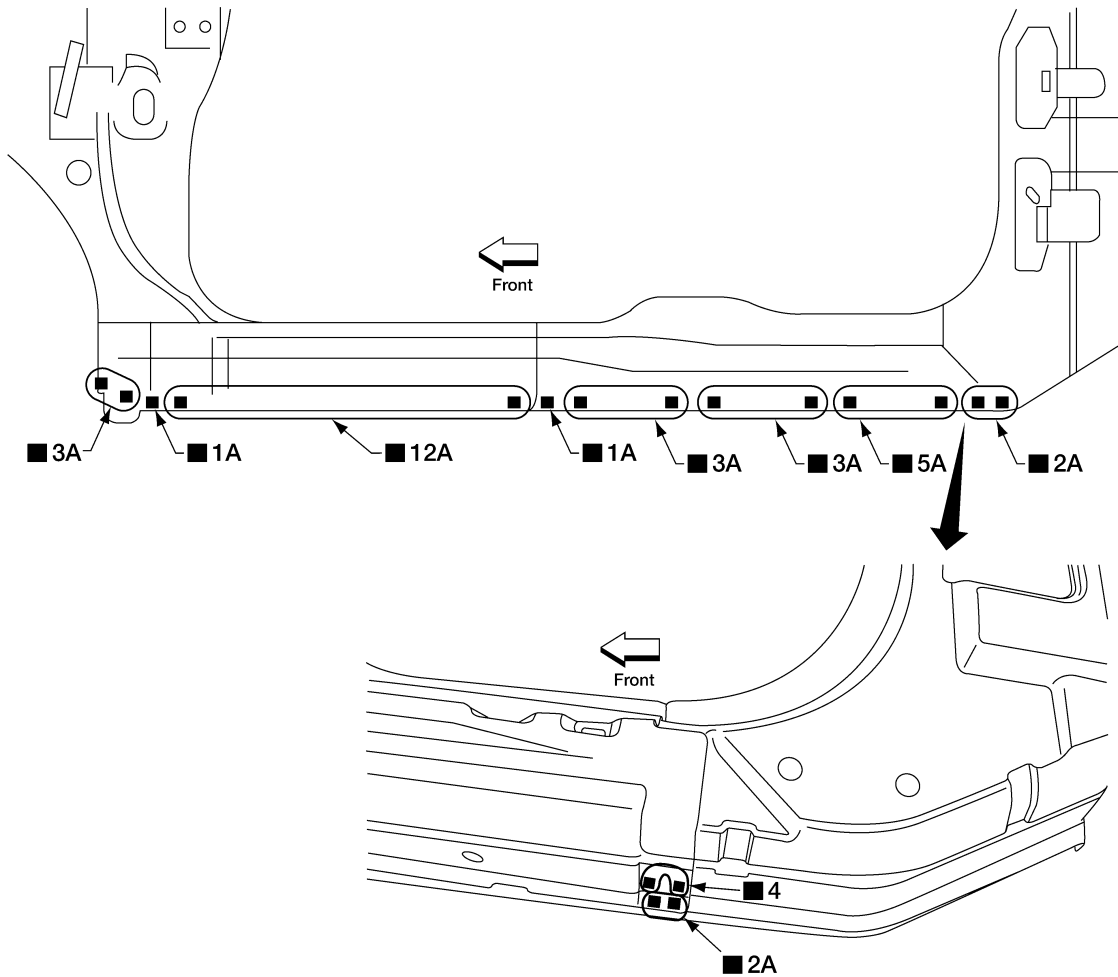

- Change parts:
- Outer sill reinforcement

CREW CAB

A
B
C
D
E
F
G
H
I
J
K
L
M
N
O
P

BRM

REPLACEMENT OPERATIONS

< UNIT REMOVAL AND INSTALLATION >

Service Joint

Front

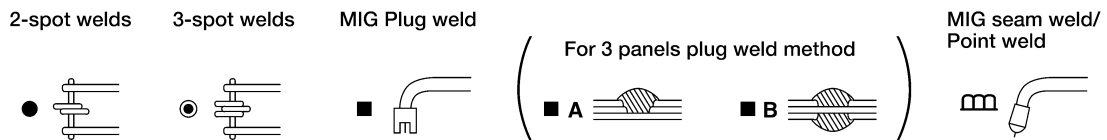
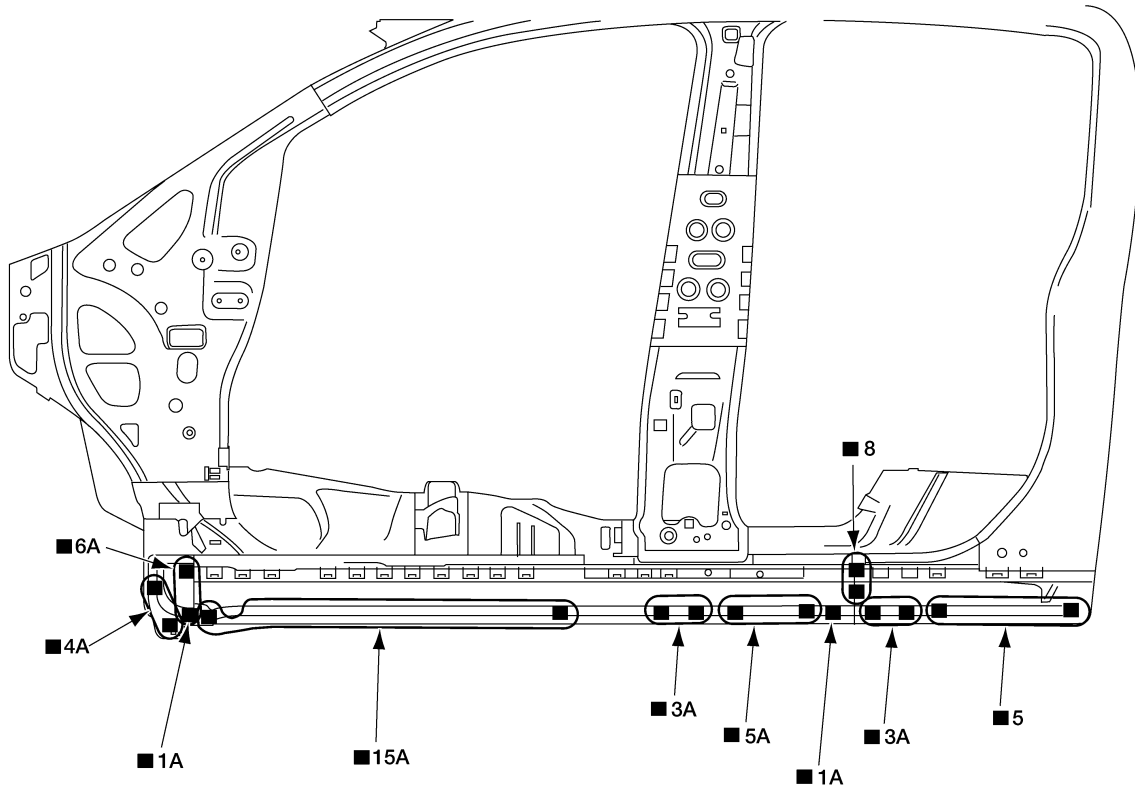

ALKIA0511GB

Change parts:

- Outer sill reinforcement

REAR CAB PILLAR

Work with rear panel removed.

KING CAB

REPLACEMENT OPERATIONS

< UNIT REMOVAL AND INSTALLATION >

Rear Pillar Portion of Body Side Outer

Service Joint

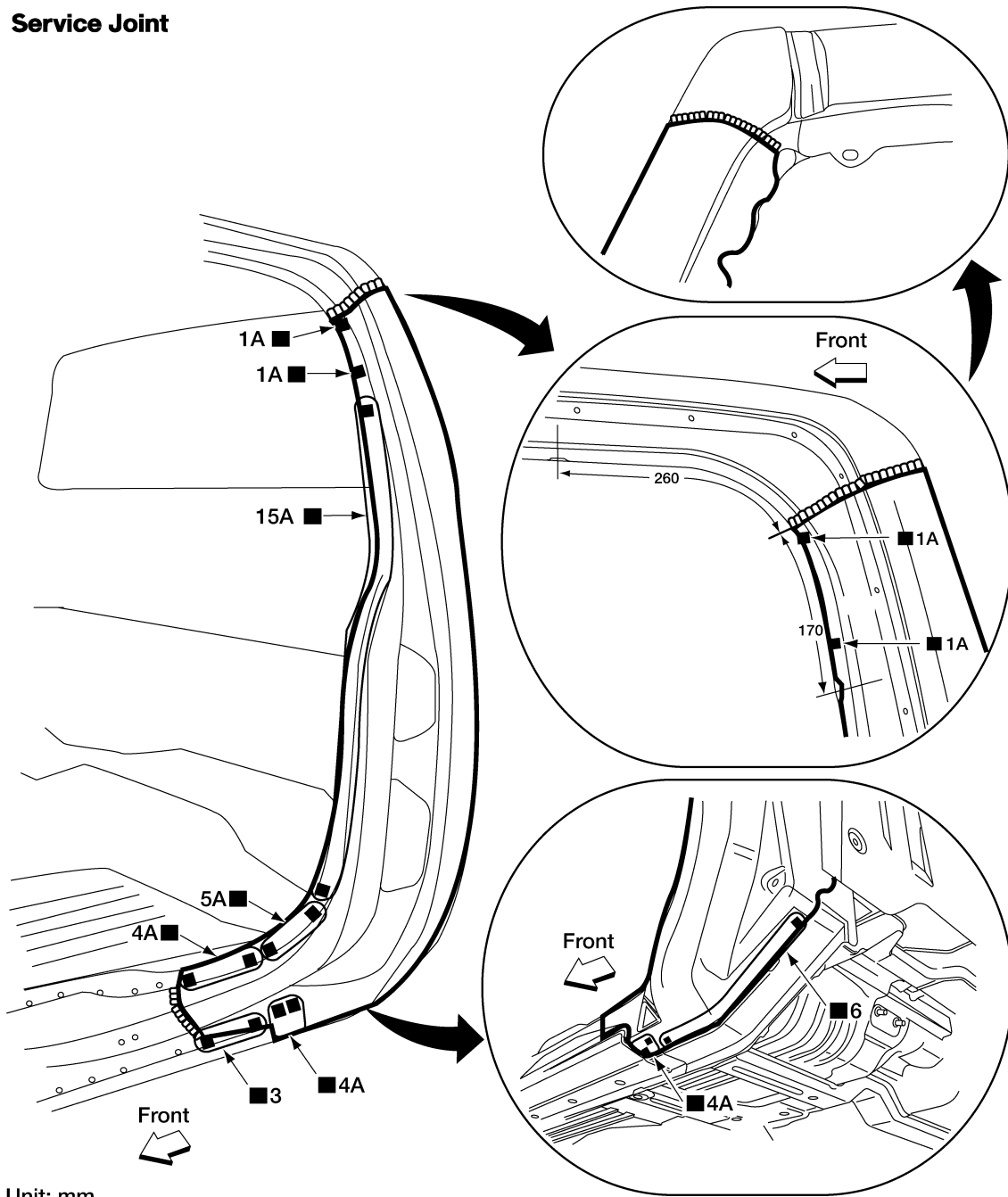

Unit: mm

2-spot welds

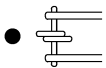

3-spot welds

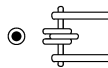

MIG Plug weld

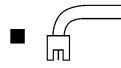

(For 3 panels plug weld method)



MIG seam weld/
Point weld



ALKIA0519GB

A
B
C
D
E
F
G
H
I
J
BRM
L
M
N
O
P

REPLACEMENT OPERATIONS

< UNIT REMOVAL AND INSTALLATION >

Service Joint

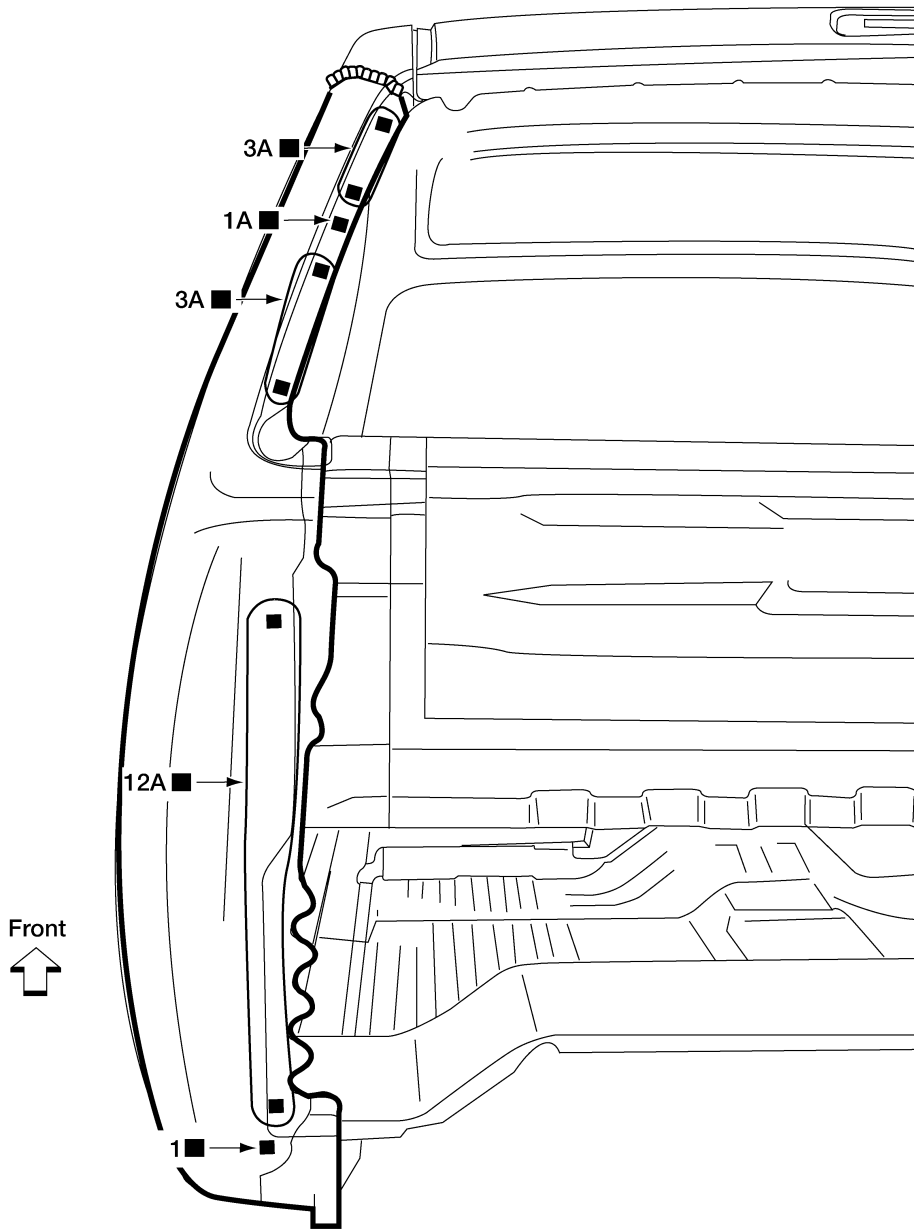

2-spot welds

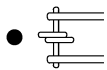

3-spot welds

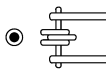

MIG Plug weld

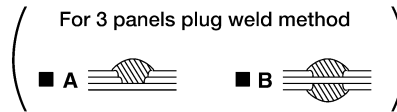
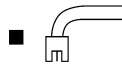

MIG seam weld/
Point weld



ALKIA0523GB

Change parts:

- Rear pillar portion of body side outer

REPLACEMENT OPERATIONS

< UNIT REMOVAL AND INSTALLATION >

Outer Lock Pillar Reinforcement

Service Joint

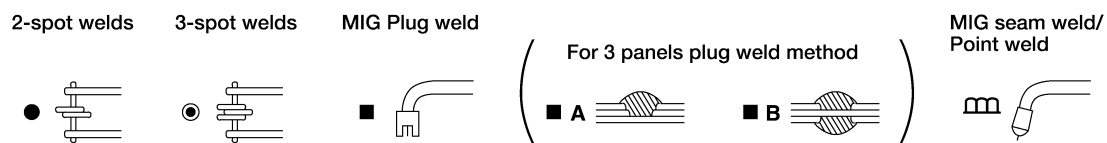
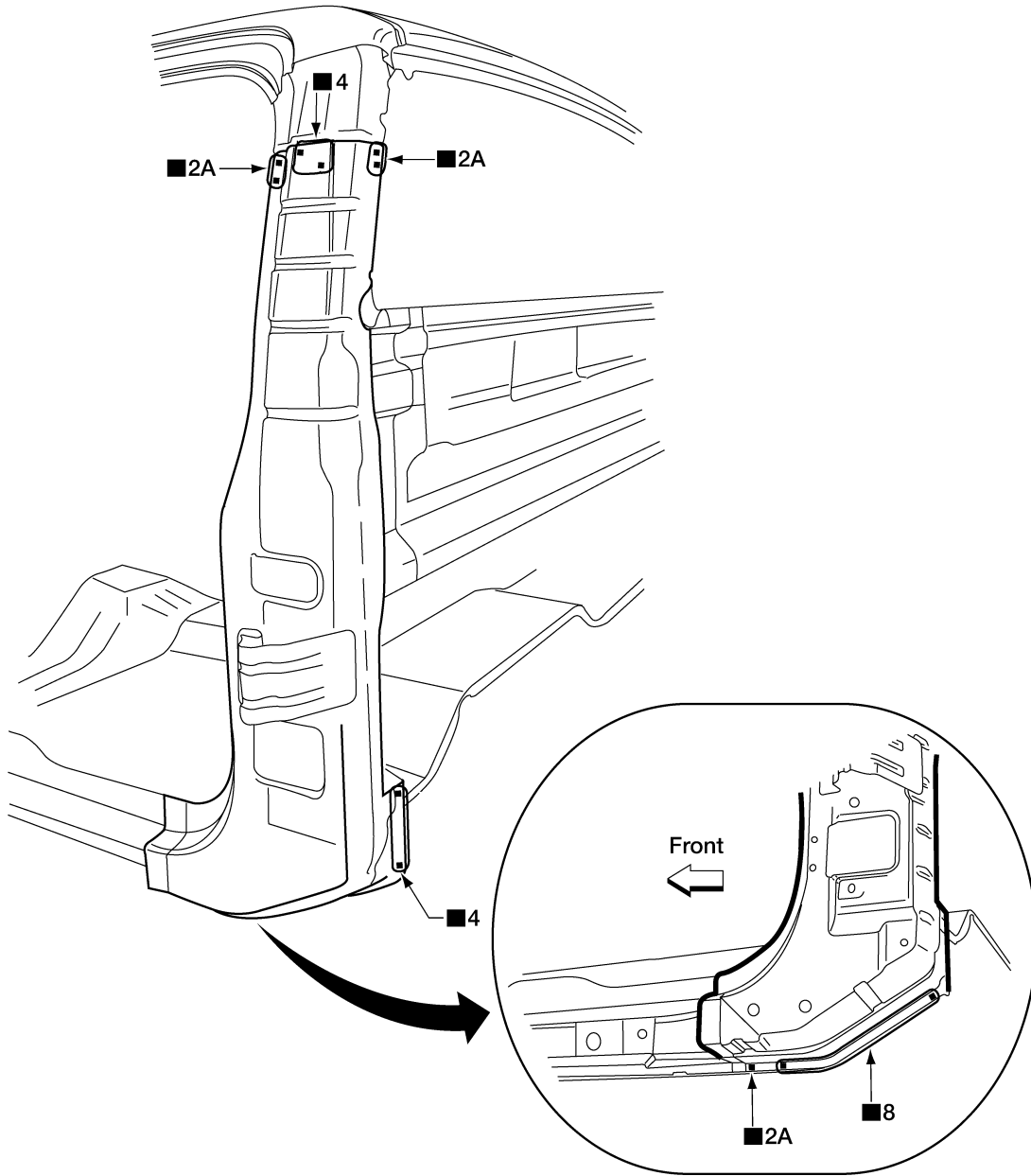

ALKIA0521GB

Change parts:

- Outer lock pillar reinforcement

CREW CAB

A
B
C
D
E
F
G
H
I
J
BRM
L
M
N
O
P

REPLACEMENT OPERATIONS

< UNIT REMOVAL AND INSTALLATION >

Rear Pillar Portion of Body Side Outer

Service Joint

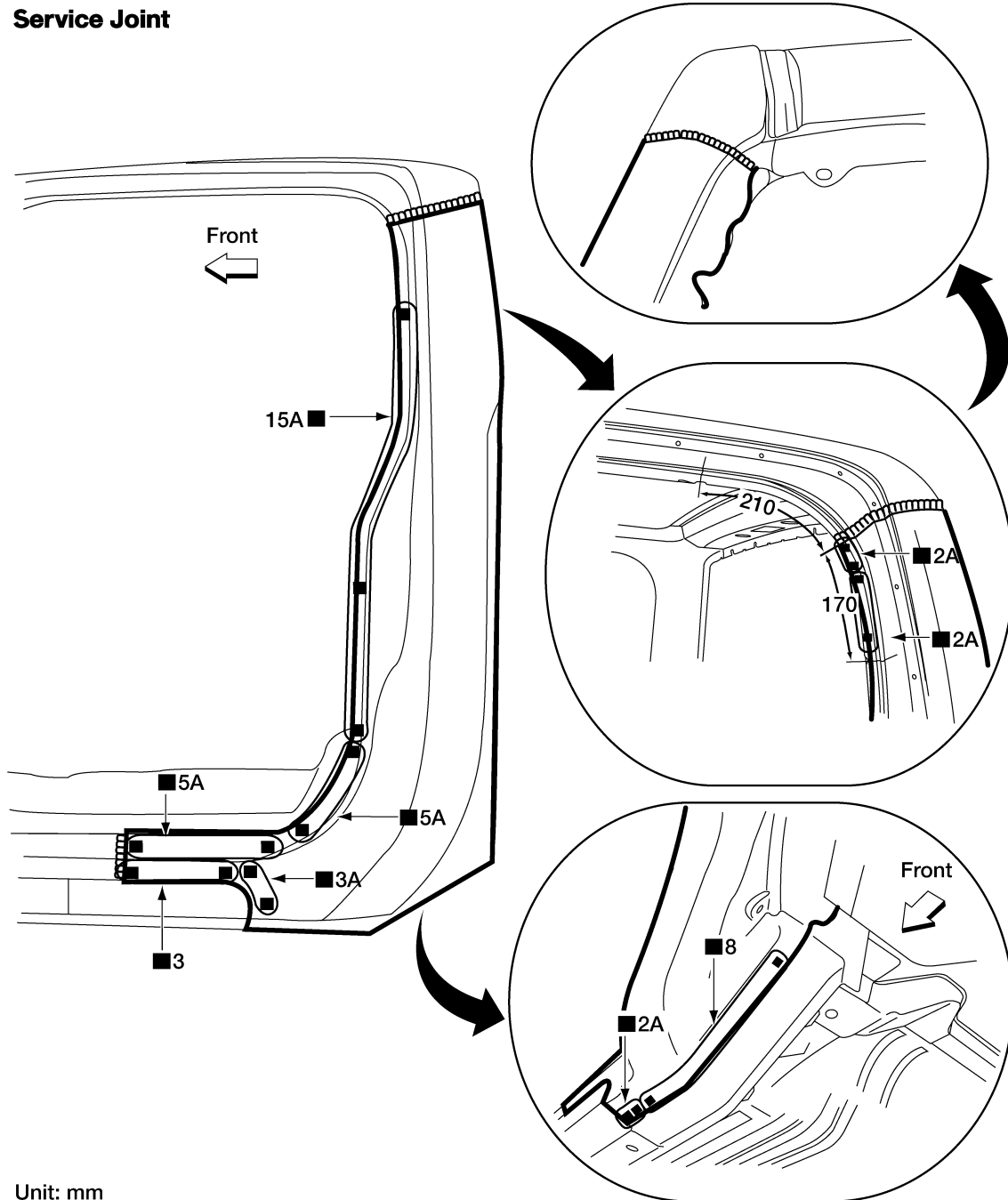

Unit: mm

2-spot welds

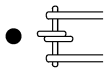

3-spot welds

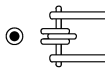

MIG Plug weld

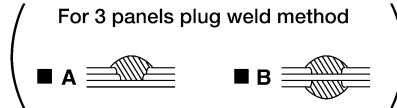
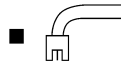

MIG seam weld/
Point weld



ALKIA0520GB

REPLACEMENT OPERATIONS

< UNIT REMOVAL AND INSTALLATION >

Service Joint

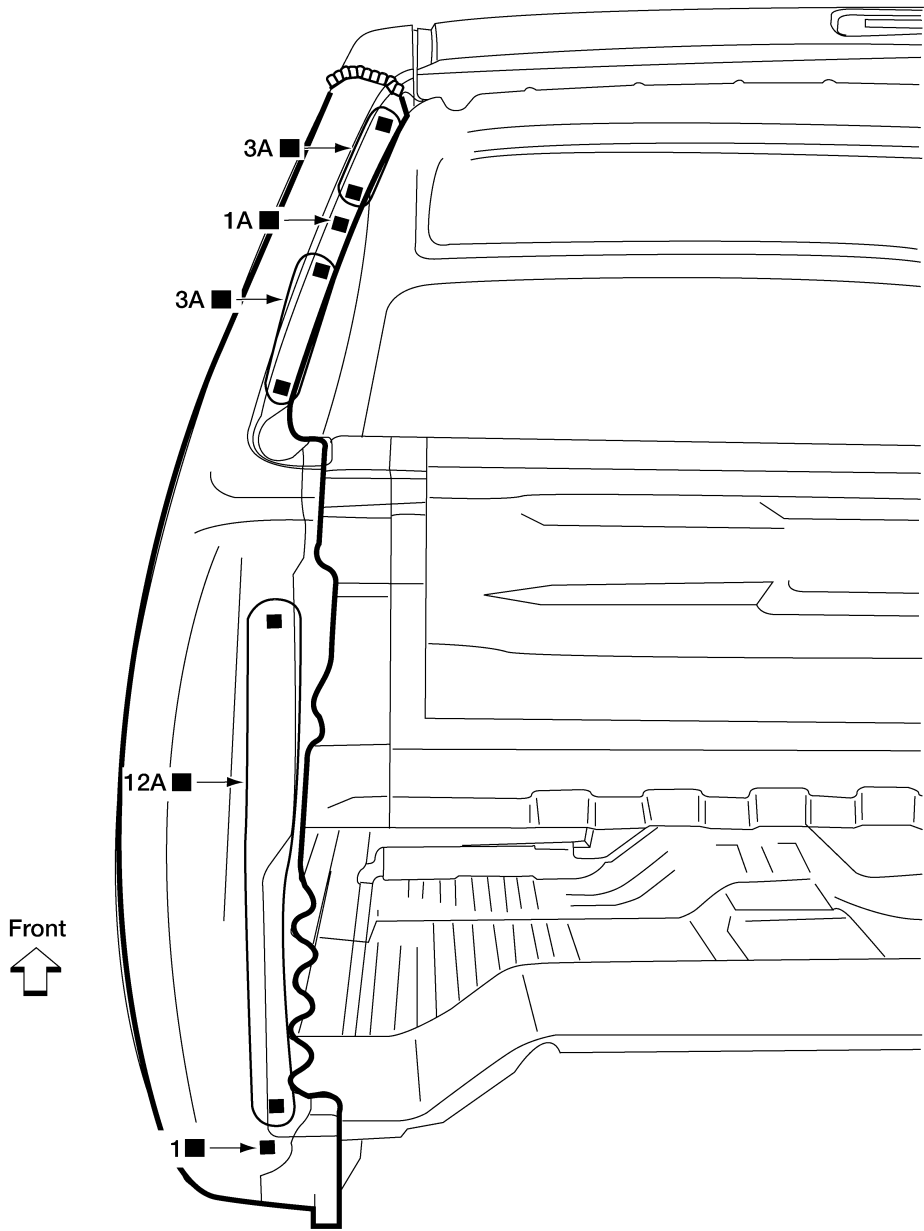

A
B
C
D
E
F
G
H
I
J
BRM
L
M
N
O
P

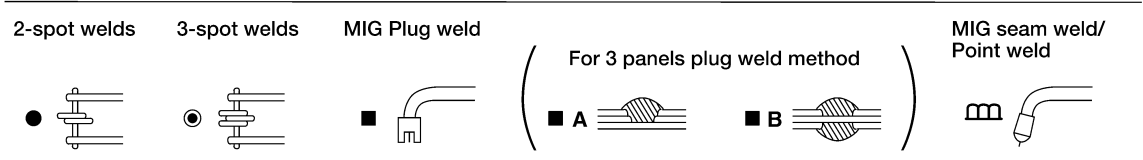

ALKIA0523GB

Change parts:

- Rear pillar portion of body side outer

REPLACEMENT OPERATIONS

< UNIT REMOVAL AND INSTALLATION >

Outer Lock Pillar Reinforcement

Service Joint

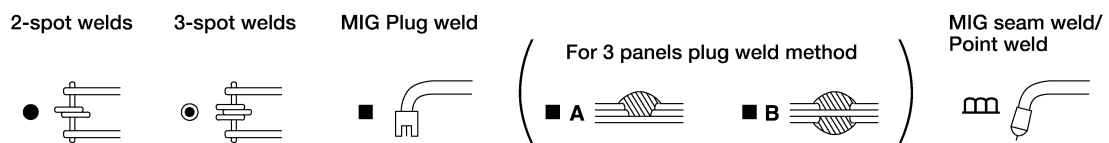
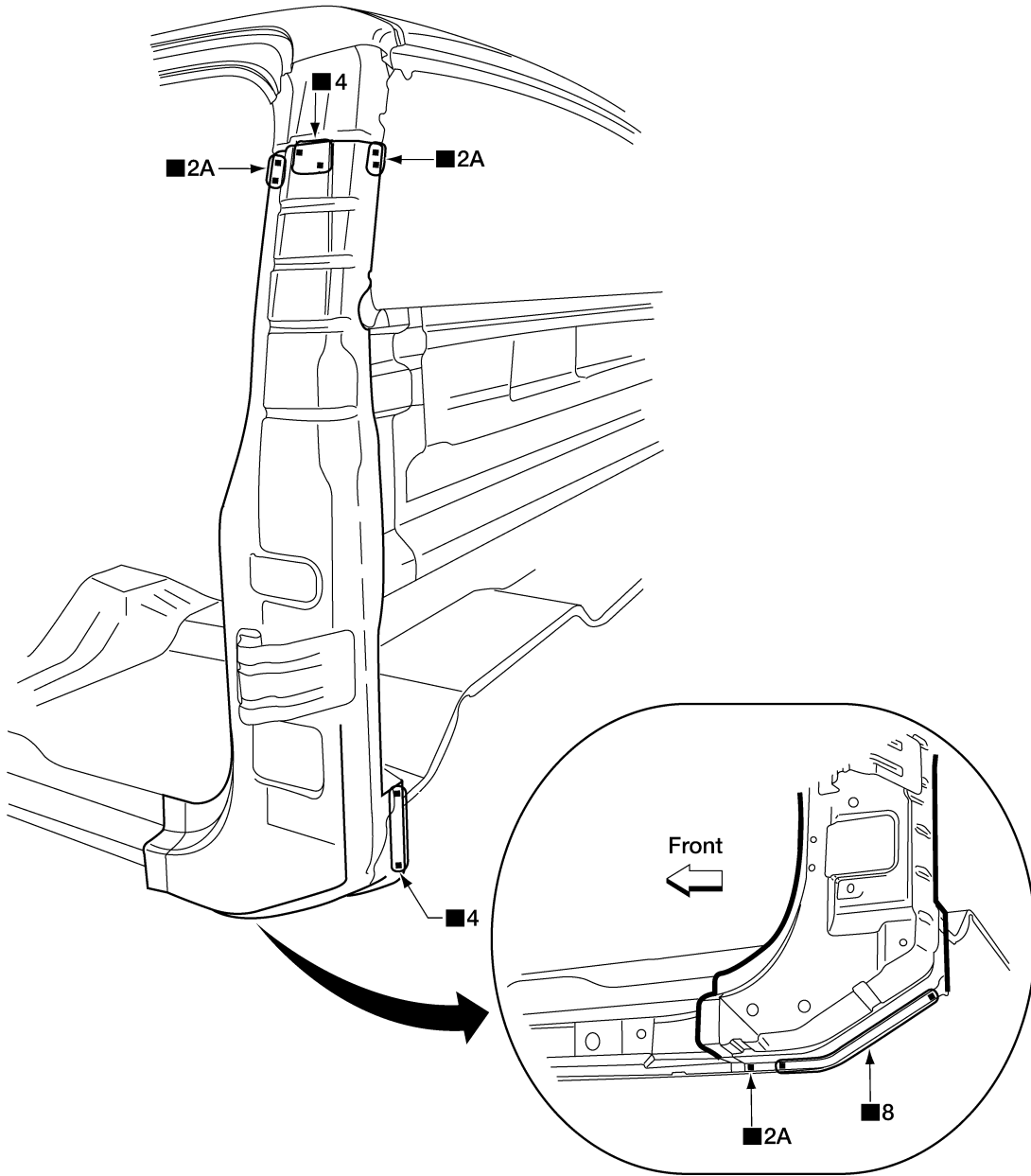

ALKIA0521GB

Change parts:

- Outer lock pillar reinforcement

REAR PANEL

REPLACEMENT OPERATIONS

< UNIT REMOVAL AND INSTALLATION >

Service Joint

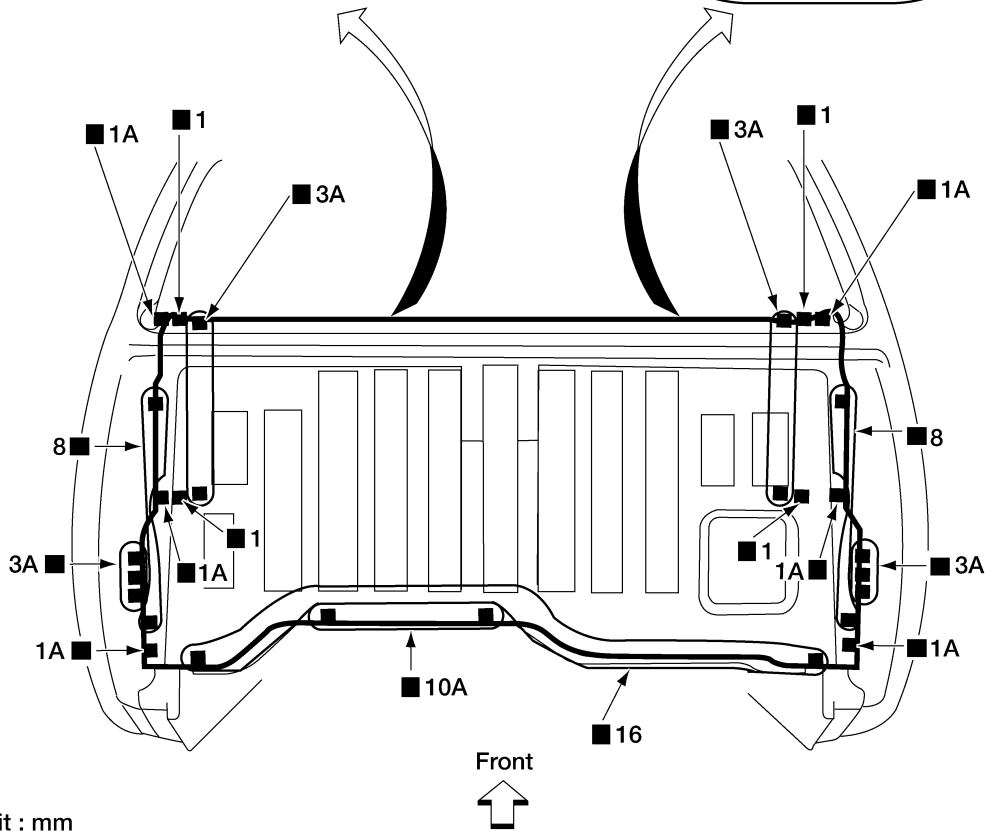
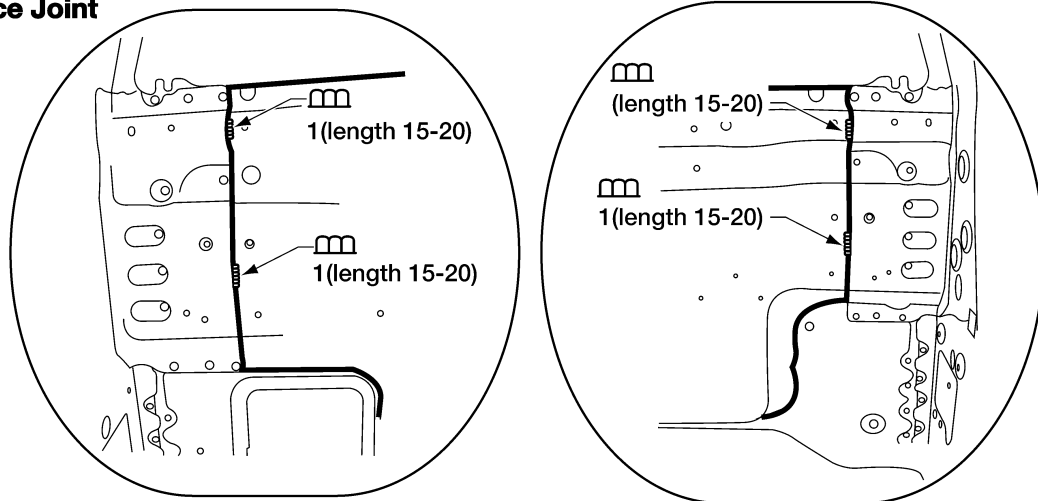

Unit : mm

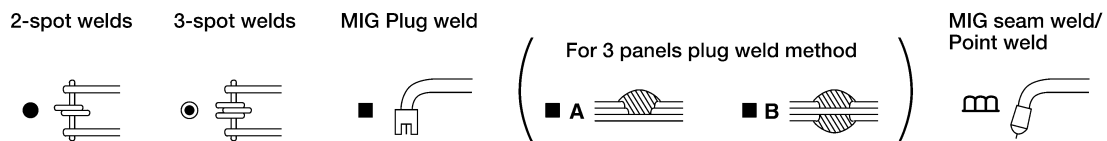

ALKIA0524GB

Change parts:

- Rear panel

REAR FLOOR REAR

KING CAB

A
B
C
D
E
F
G
H
I
J
K
L
M
N
O
P

BRM

REPLACEMENT OPERATIONS

< UNIT REMOVAL AND INSTALLATION >

Service Joint

Front

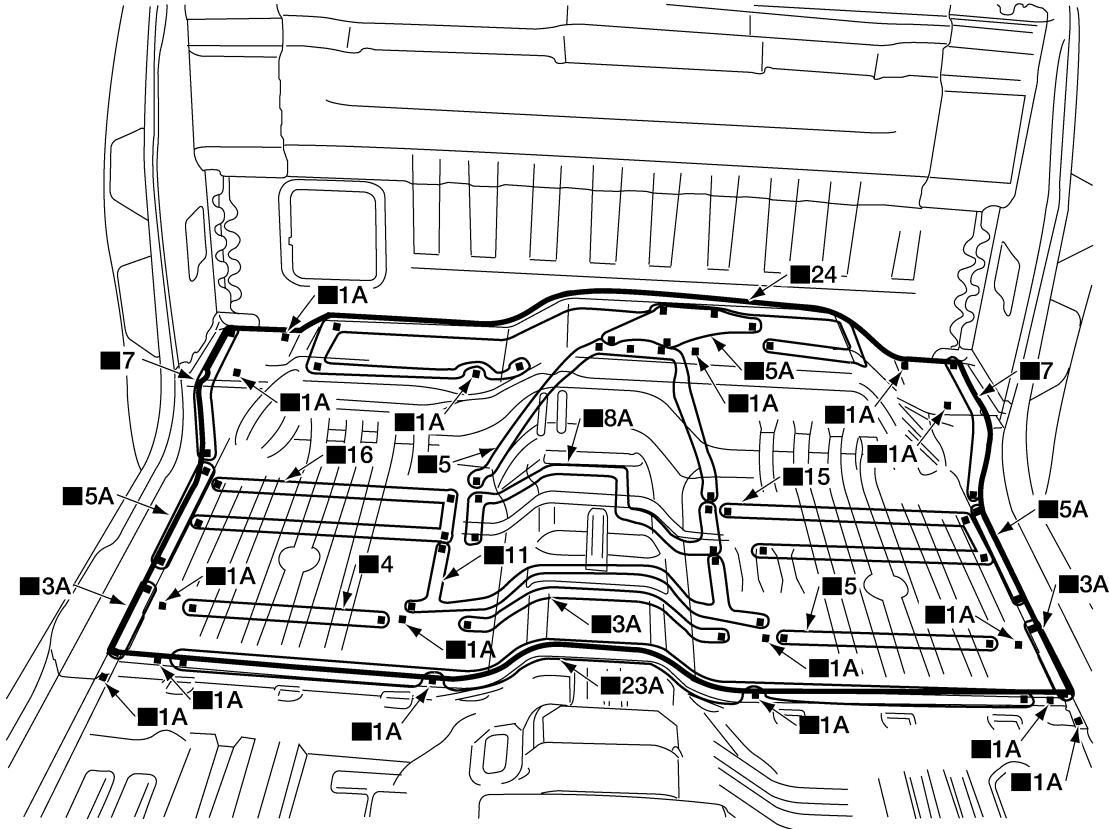

2-spot welds

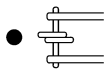

3-spot welds

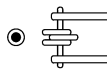

MIG Plug weld

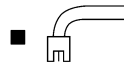

For 3 panels plug weld method



MIG seam weld/
Point weld



ALKIA0525GB

Change parts:

- Rear floor rear

CREW CAB

REPLACEMENT OPERATIONS

< UNIT REMOVAL AND INSTALLATION >

Service Joint

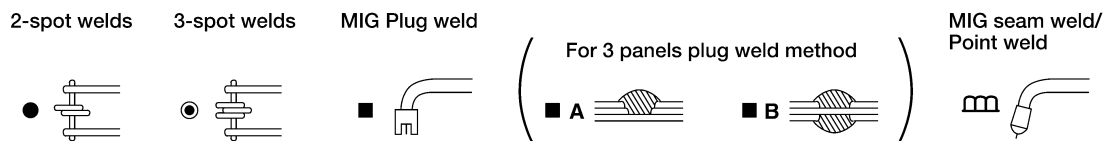
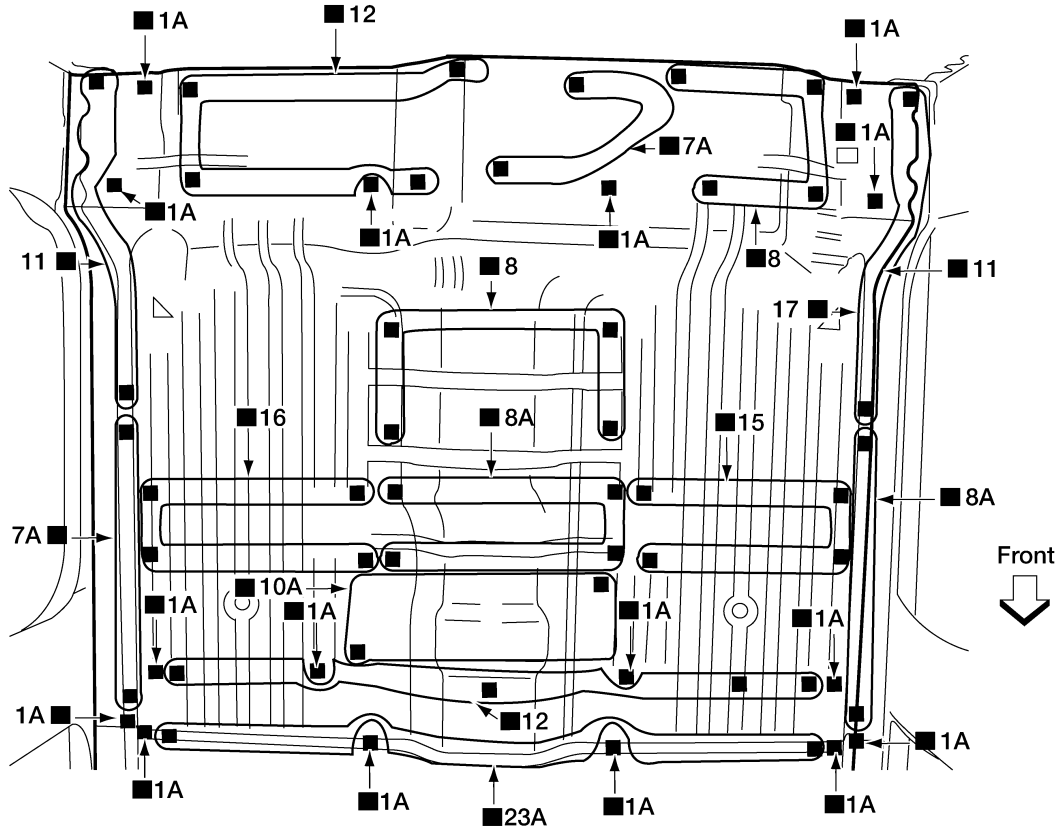

ALKIA0526GB

Change parts:

- Rear floor rear

PICKUP BED

Header Panel Assembly

A
B
C
D
E
F
G
H
I
J
BRM
L
M
N
O
P

REPLACEMENT OPERATIONS

< UNIT REMOVAL AND INSTALLATION >

Service Joint

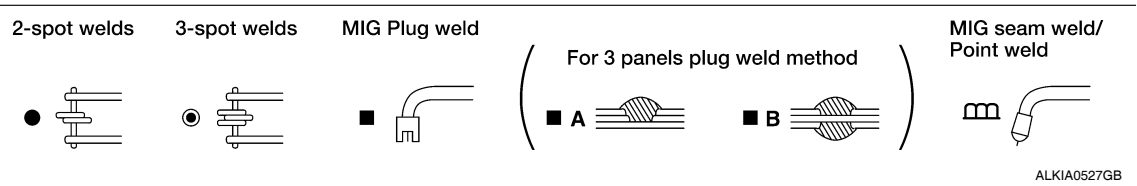
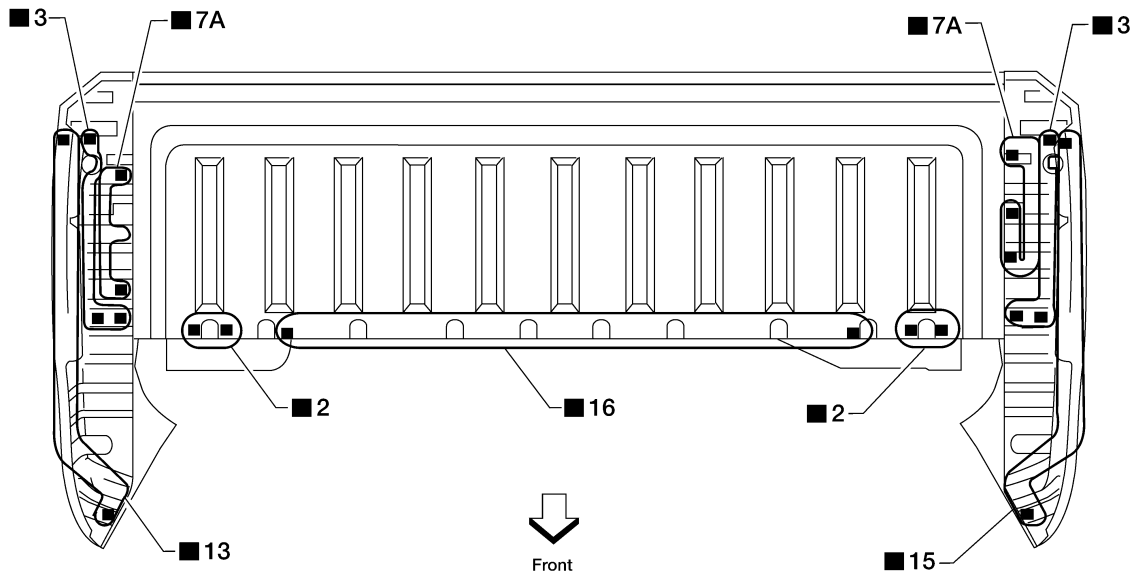

ALKIA0527GB

Change parts

- Header panel
- Front strut

Bed Side Outer

REPLACEMENT OPERATIONS

< UNIT REMOVAL AND INSTALLATION >

King Cab

Service Joint

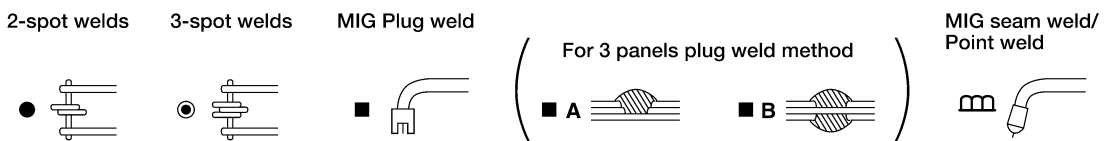
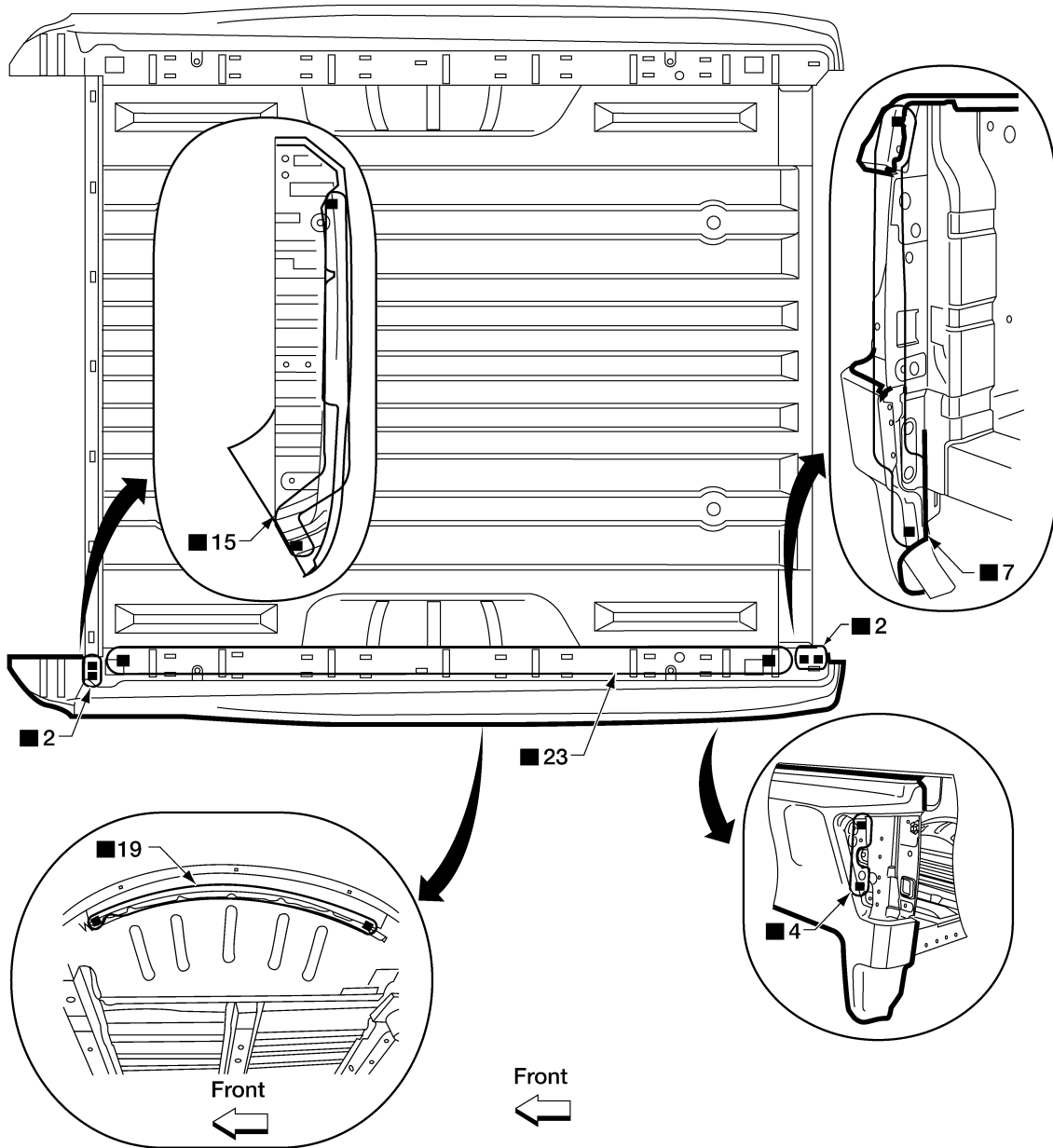

ALKIA0531GB

Change parts

- Bed side outer

A
B
C
D
E
F
G
H
I
J
BRM
L
M
N
O
P

REPLACEMENT OPERATIONS

< UNIT REMOVAL AND INSTALLATION >

Crew Cab

Service Joint

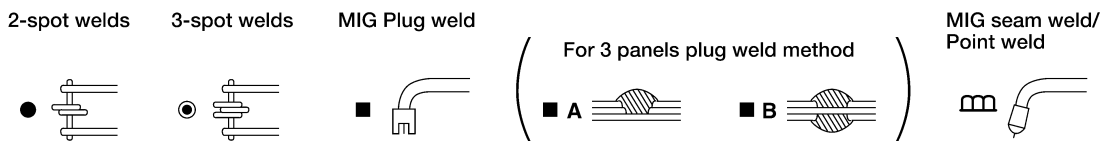
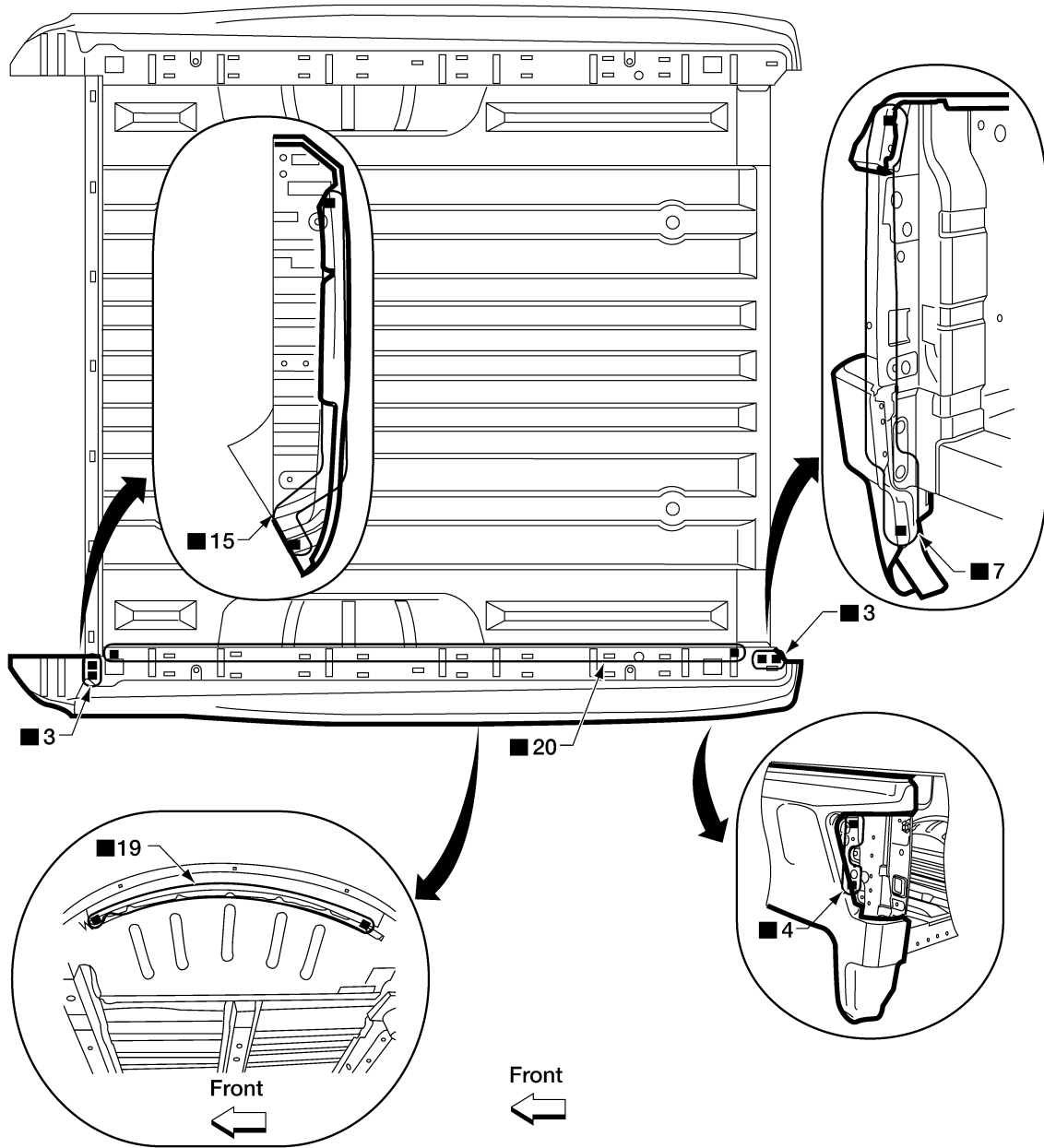

ALKIA0532GB

Change parts

- Bed side outer

REPLACEMENT OPERATIONS

< UNIT REMOVAL AND INSTALLATION >

Long Bed

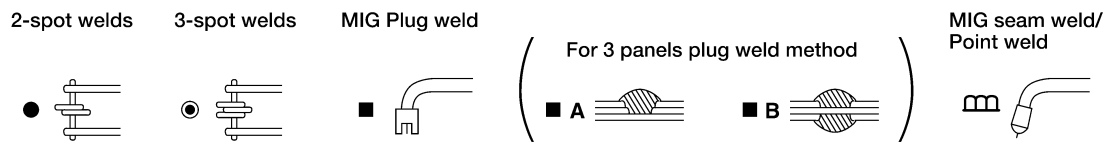
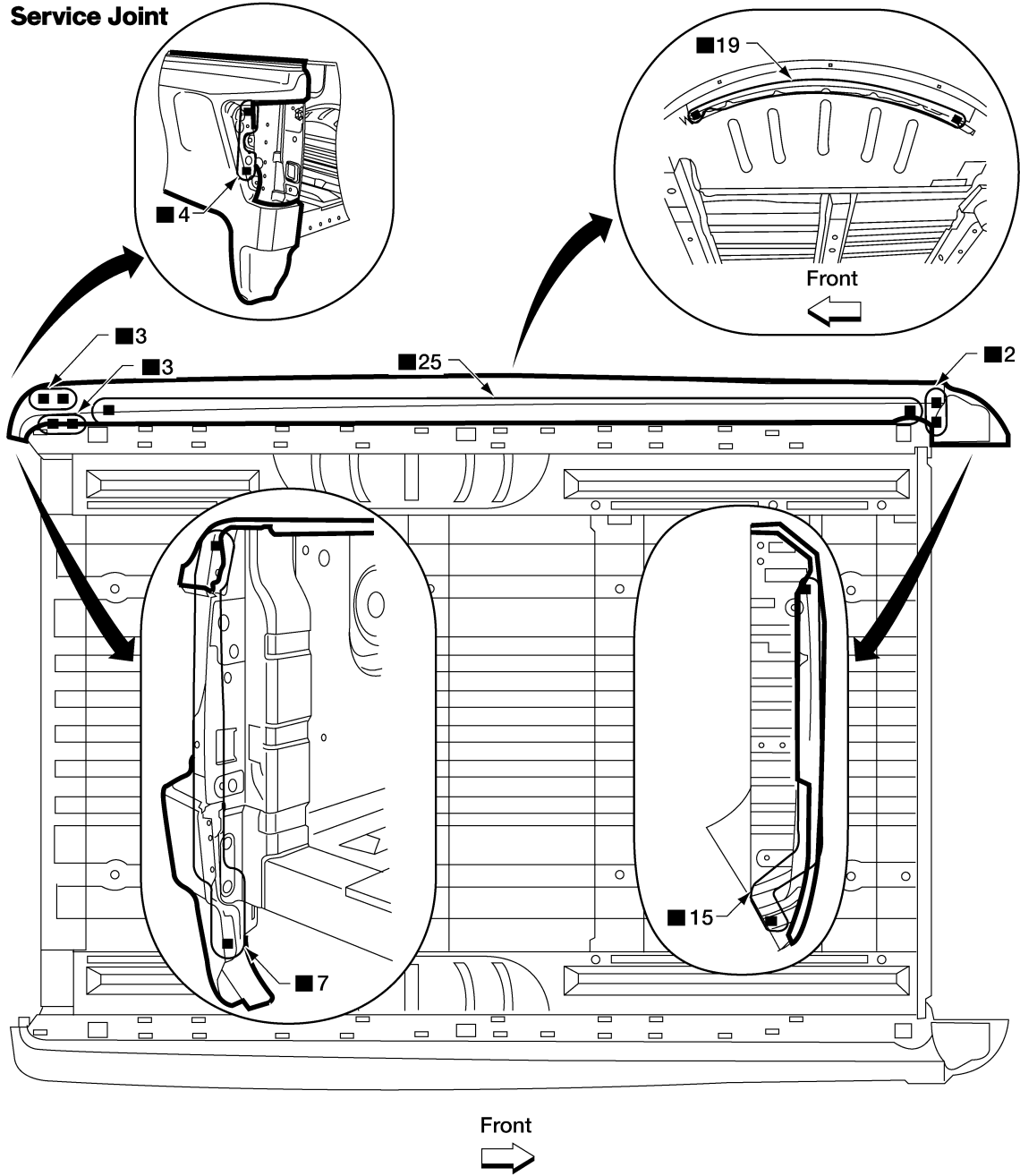

ALKIA0529GB

Change parts

- Bed side outer

Bed Side Inner

Work with bed side outer and header panel assembly removed.

A
B
C
D
E
F
G
H
I
J
BRM
L
M
N
O
P

REPLACEMENT OPERATIONS

< UNIT REMOVAL AND INSTALLATION >

King Cab

Service Joint

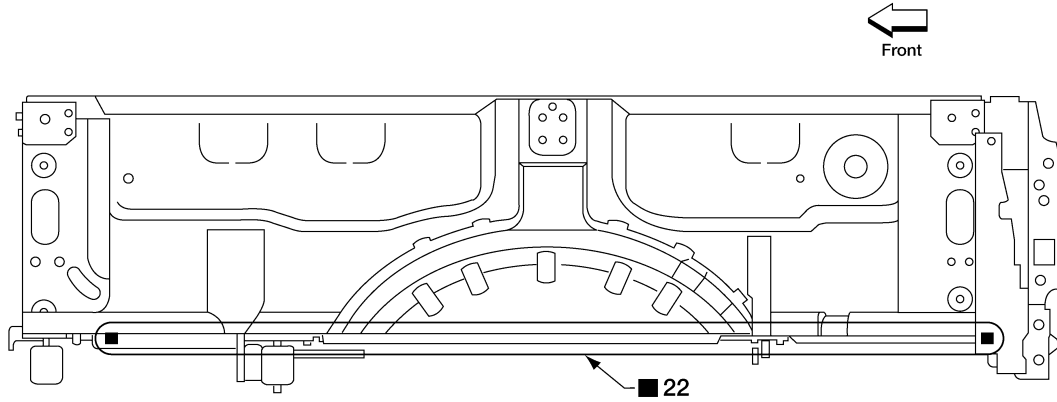

2-spot welds

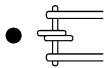

3-spot welds

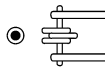

MIG Plug weld

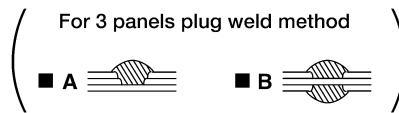
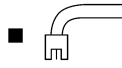

MIG seam weld/
Point weld



ALKIA0533GB

Change parts

- Bed side inner

REPLACEMENT OPERATIONS

< UNIT REMOVAL AND INSTALLATION >

Crew Cab

Service Joint

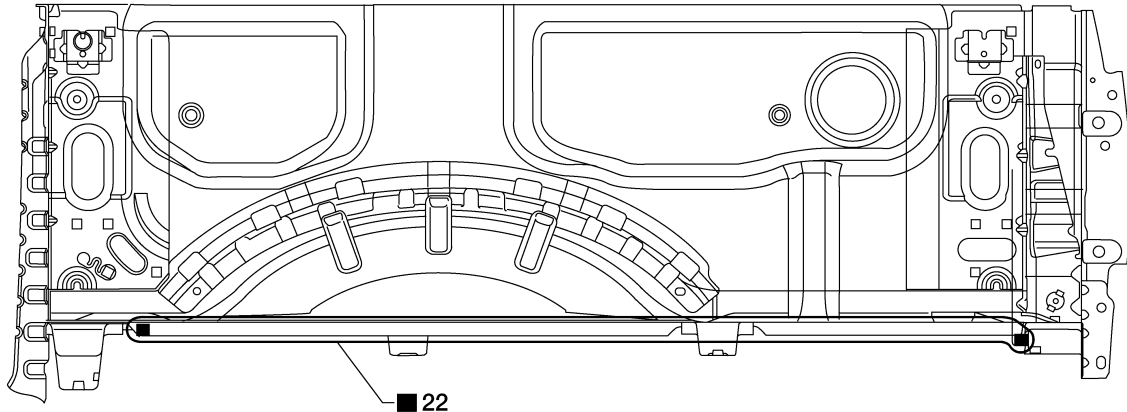

A
B
C
D
E
F
G
H
I
J

BRM

L
M
N
O
P

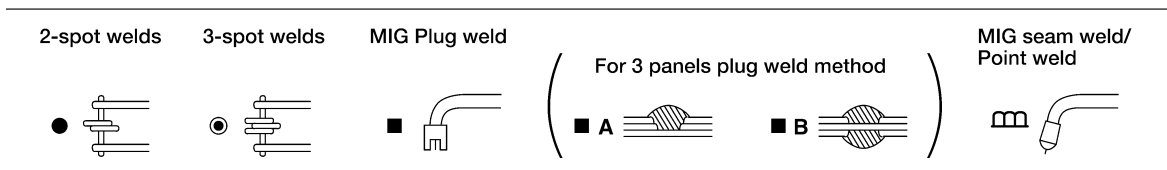

ALKIA0534GB

- Change parts
- Bed side inner

REPLACEMENT OPERATIONS

< UNIT REMOVAL AND INSTALLATION >

Long Bed

Service Joint

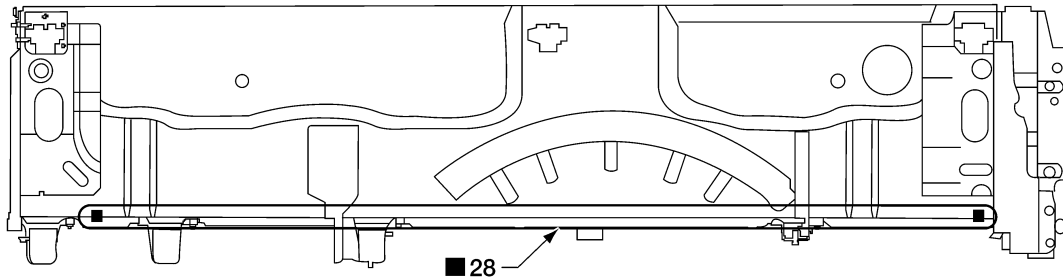

Front
←

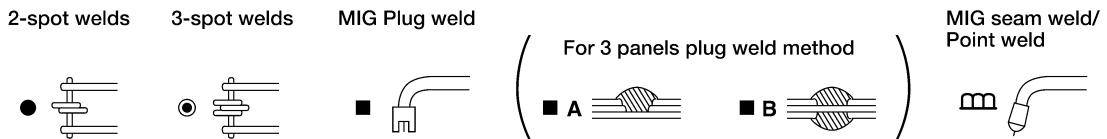

ALKIA0528GB

Change parts

- Bed side inner

Rear Body Floor

REPLACEMENT OPERATIONS

< UNIT REMOVAL AND INSTALLATION >

King cab

Service Joint

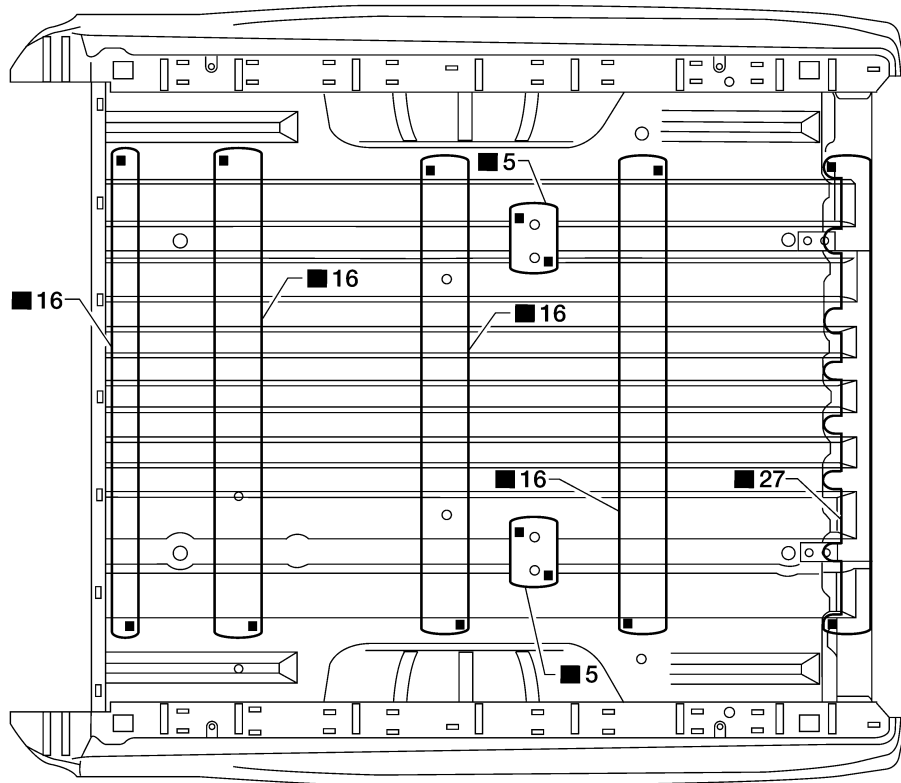

←
Front

A
B
C
D
E
F
G
H
I
J

BRM

L
M
N
O
P

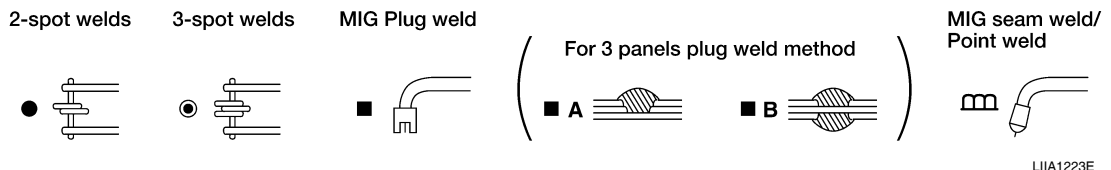

- Change parts
- Rear body floor assembly

REPLACEMENT OPERATIONS

< UNIT REMOVAL AND INSTALLATION >

Crew cab

Service Joint

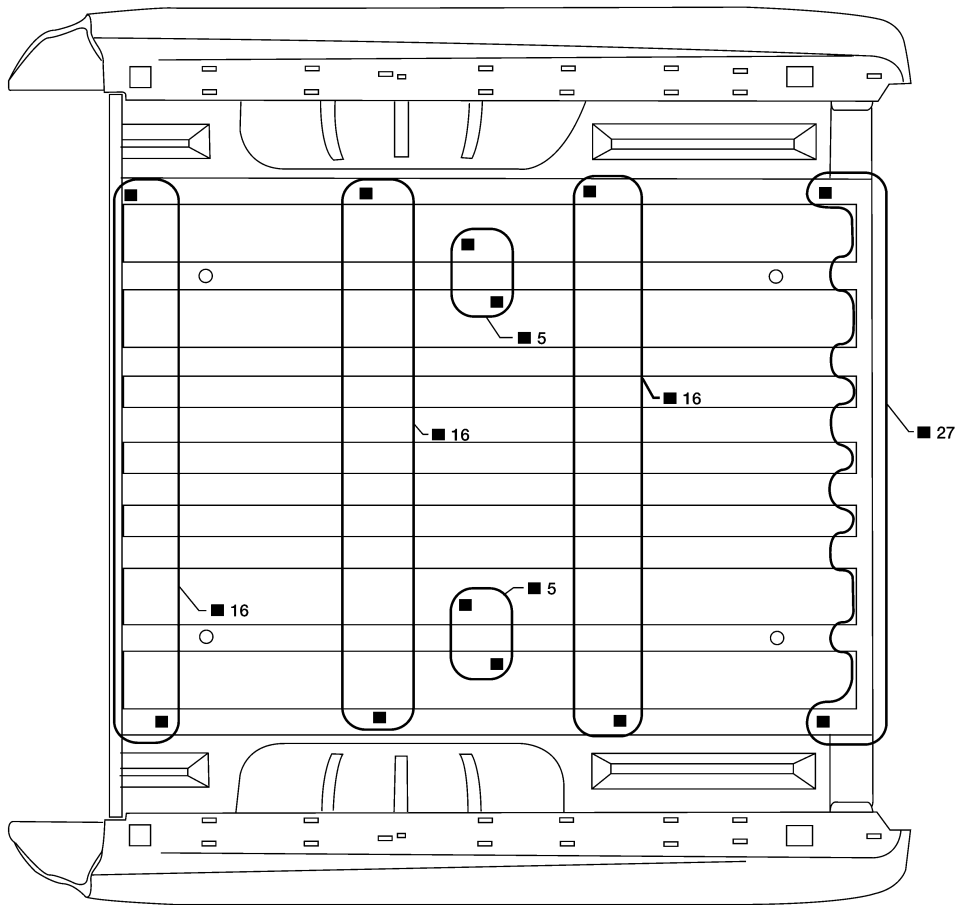

←
Front

2-spot welds

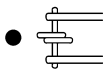

3-spot welds

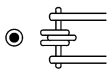

MIG Plug weld

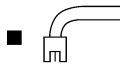

For 3 panels plug weld method



MIG seam weld/
Point weld



LIIA1224E

Change parts

- Rear body floor assembly

REPLACEMENT OPERATIONS

< UNIT REMOVAL AND INSTALLATION >

Long Bed

Service Joint

Front
←

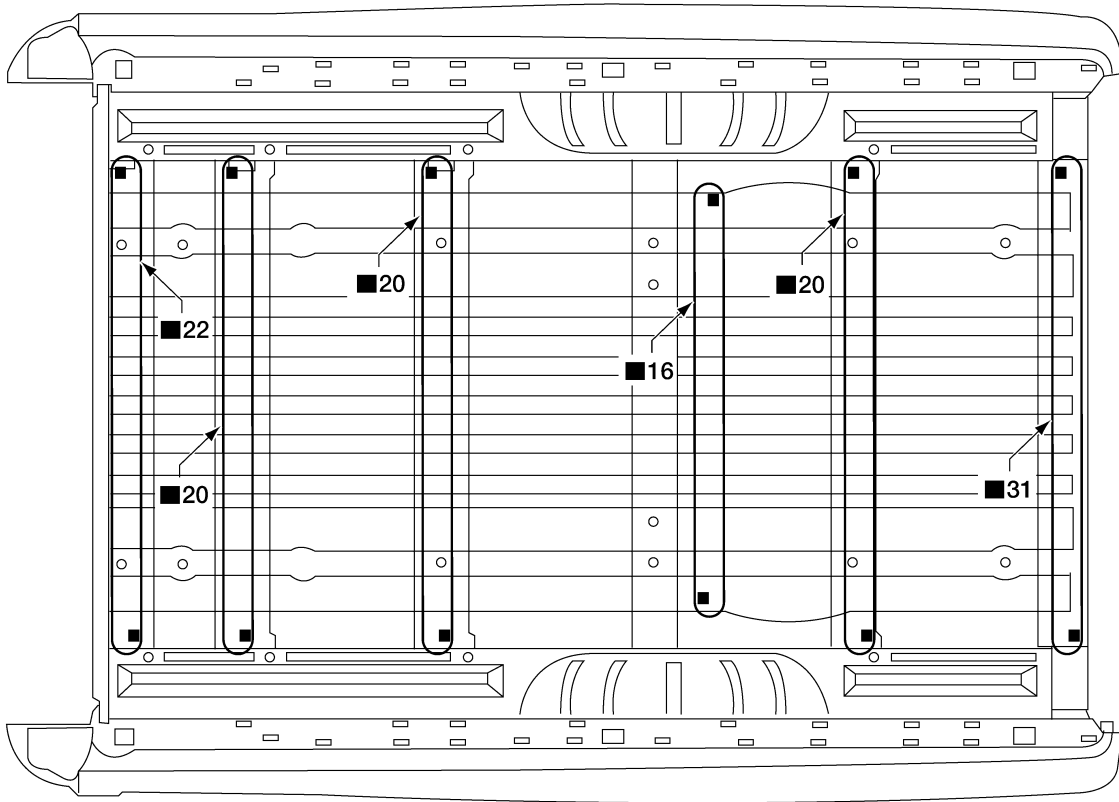

A
B
C
D
E
F
G
H
I
J

BRM

L
M
N
O
P

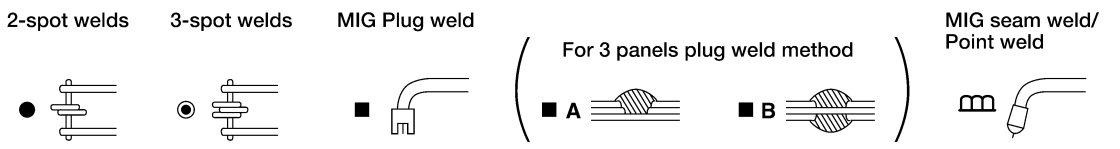

ALKIA0530GB

- Change parts
- Rear body floor assembly

Rear Strut
Work with bed side outer removed.

REPLACEMENT OPERATIONS

< UNIT REMOVAL AND INSTALLATION >

Service Joint

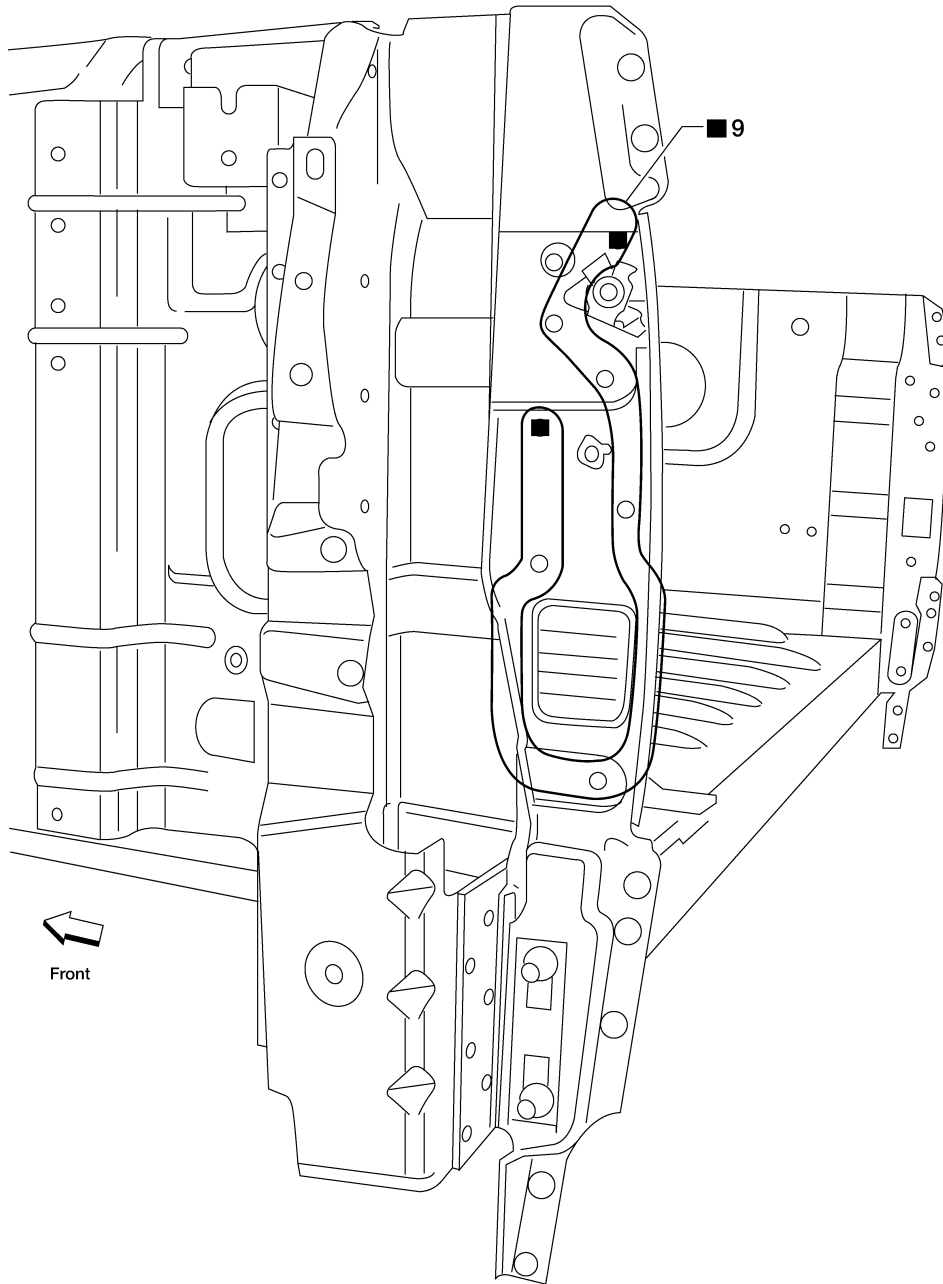

2-spot welds

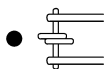

3-spot welds



MIG Plug weld

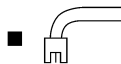

For 3 panels plug weld method



MIG seam weld/
Point weld



AWKIA1105ZZ

Change parts:

- Inner rear strut assembly

REPLACEMENT OPERATIONS

< UNIT REMOVAL AND INSTALLATION >

Service Joint

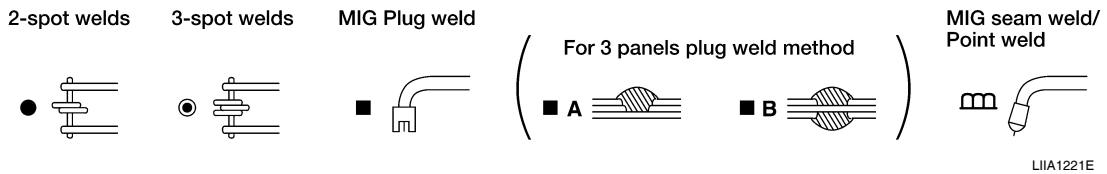
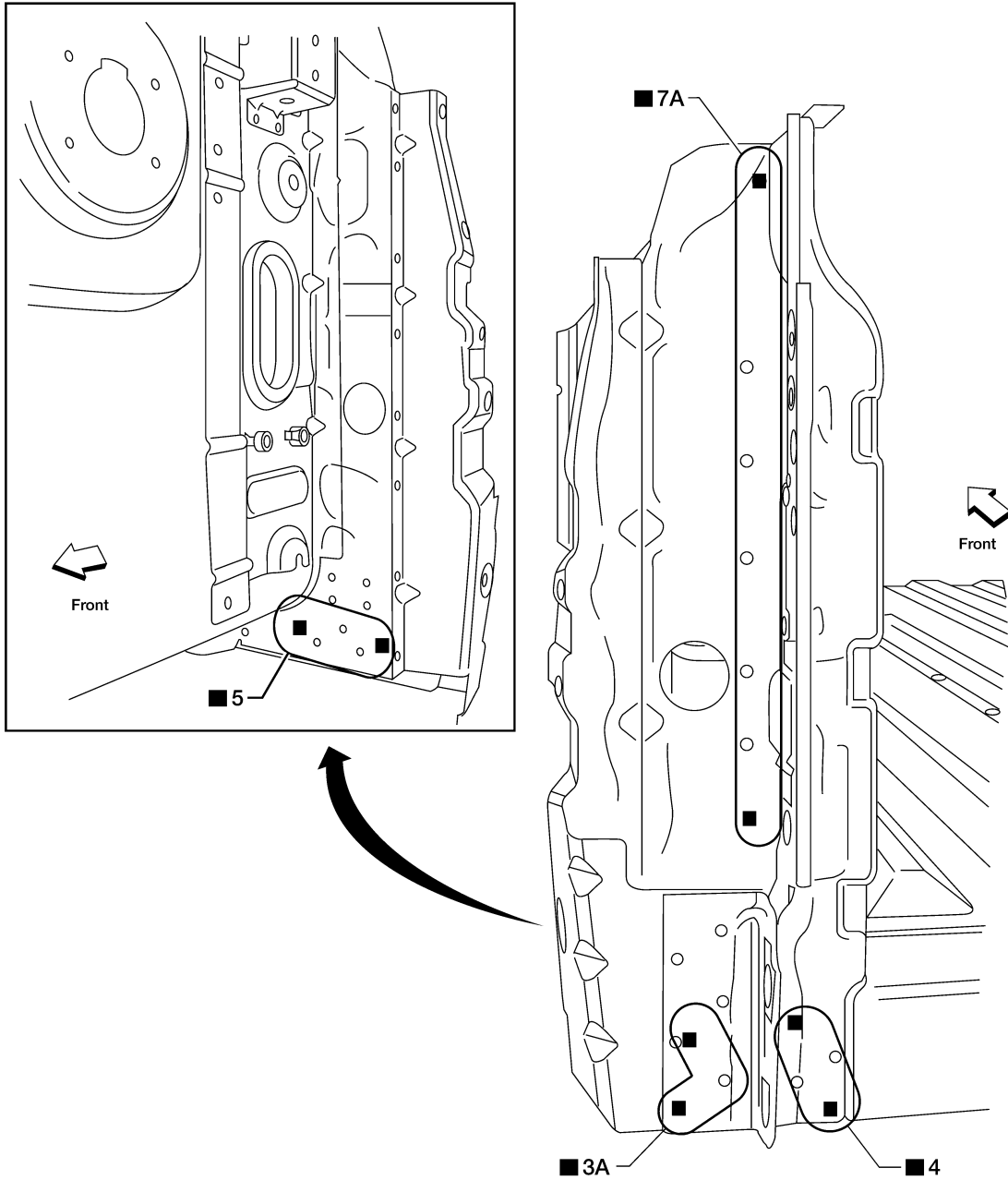

- Change parts:
- Rear strut assembly

CRUSH HORN

A
B
C
D
E
F
G
H
I
J
BRM
L
M
N
O
P

REPLACEMENT OPERATIONS

< UNIT REMOVAL AND INSTALLATION >

- Work after 1st crossmember has been removed.

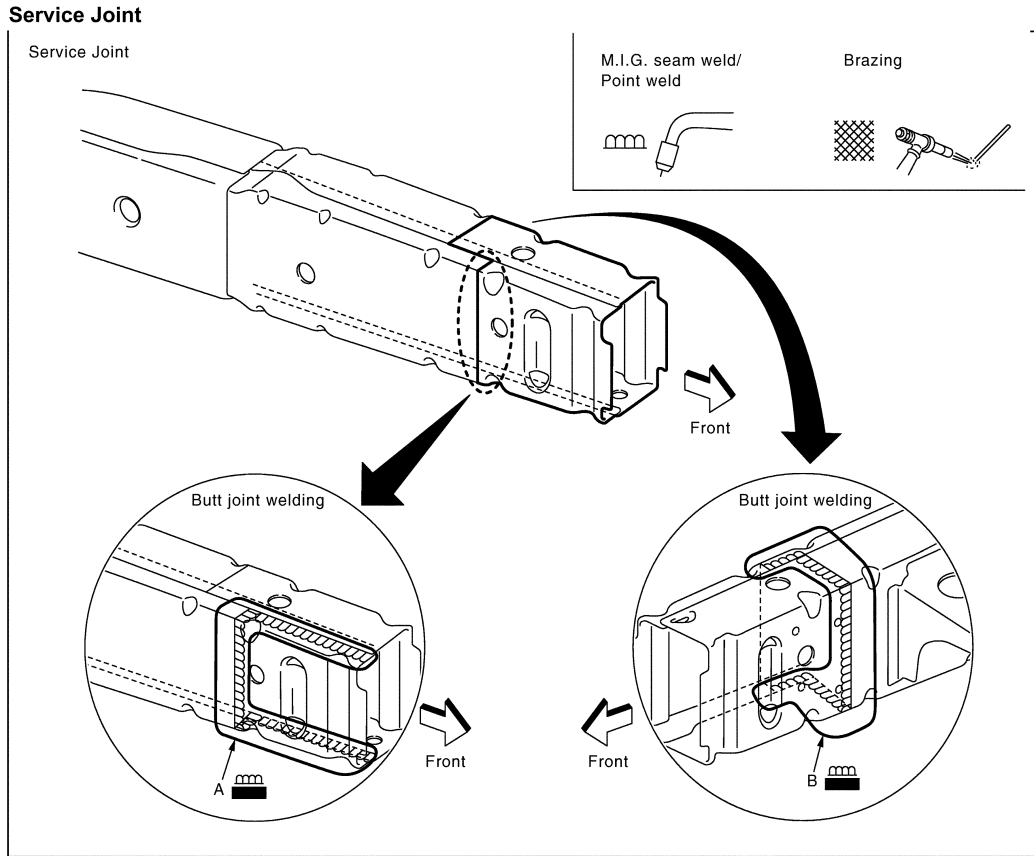

LIIA1083E

Portions to be welded:

- A. Inner side rail crush horn, inner side rail crush horn and outer side rail crush horn.
- B. Outer side rail crush horn, outer side rail crush horn and inner side rail crush horn.

Removal Notes

REPLACEMENT OPERATIONS

< UNIT REMOVAL AND INSTALLATION >

- Scribe a straight line on the outer side rail crush horn and inner side rail crush horn along the hole center as shown in the figure.

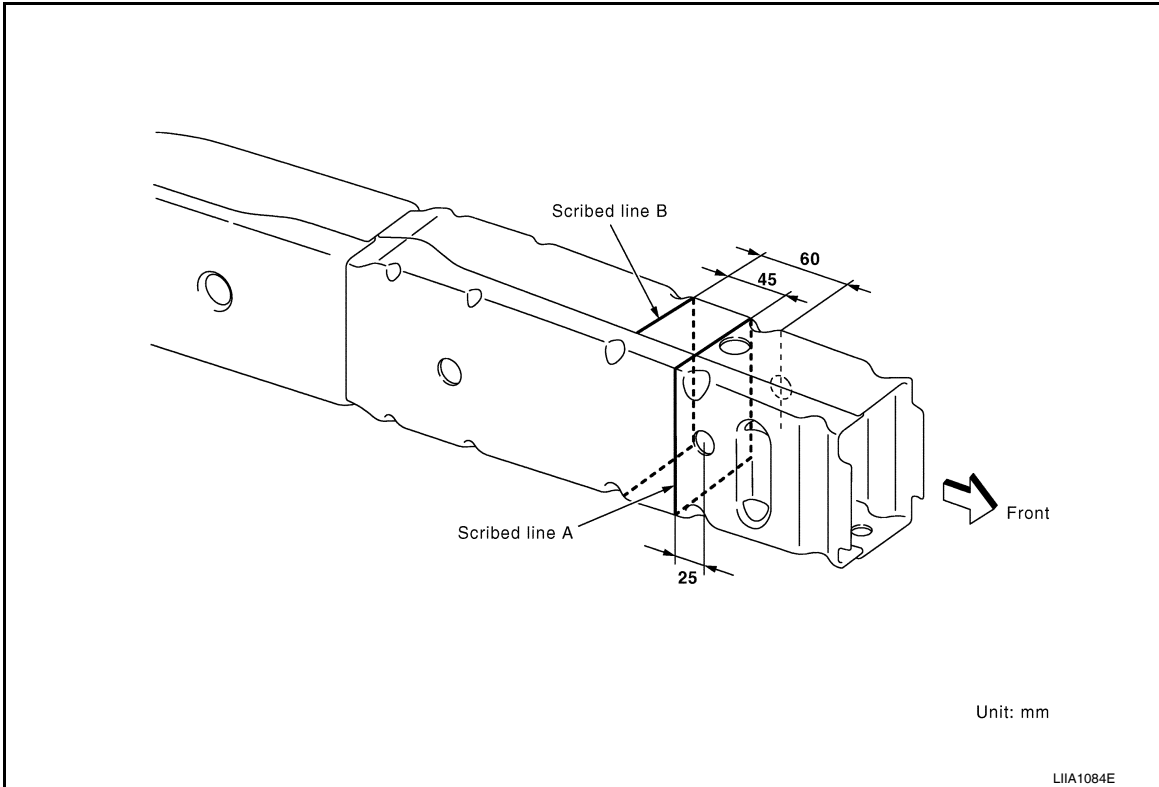

- Cut off outer side rail crush horn and inner side rail crush horn along scribed line A. Do not cut on the hole.

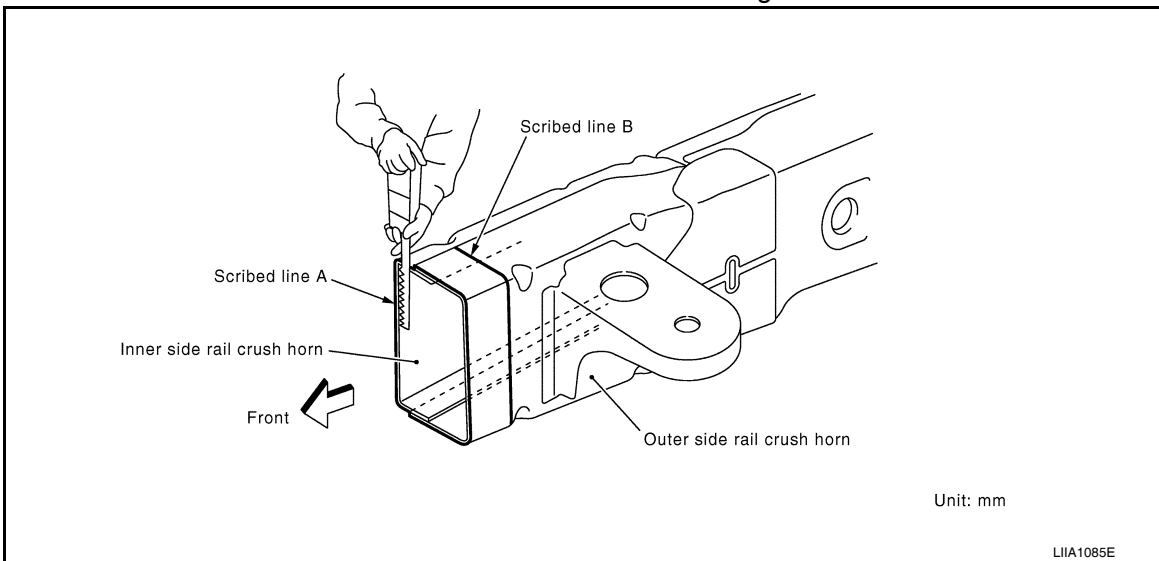

- Cut inner side rail crush horn at 45 mm backward cut position of cut line A. (along line B)

A
B
C
D
E
F
G
H
I
J
K
L
M
N
O
P

BRM

REPLACEMENT OPERATIONS

< UNIT REMOVAL AND INSTALLATION >

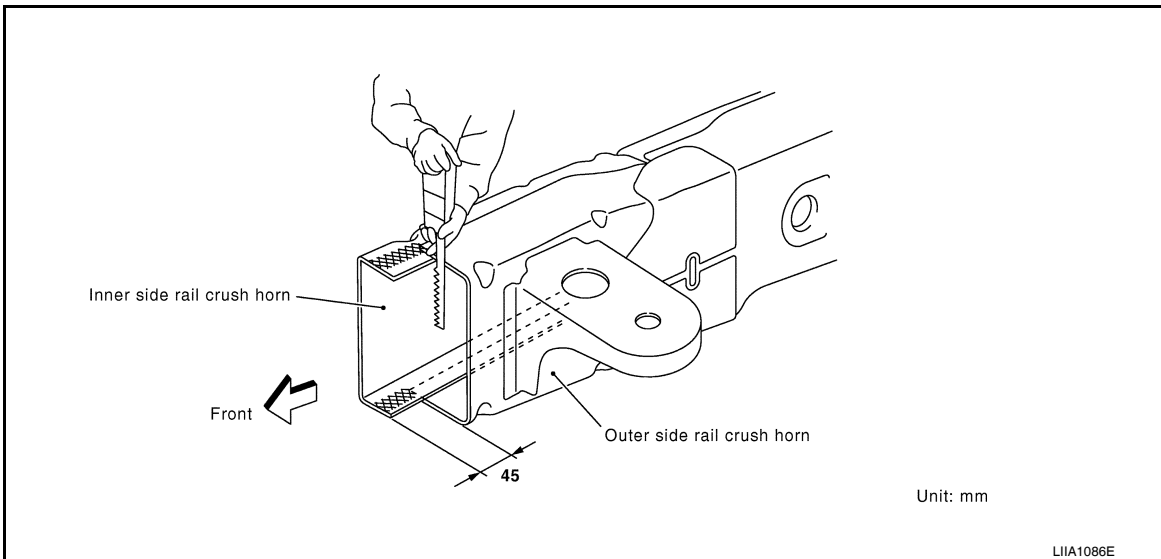

- After removing outer panel, dress area on the inner panel surface with a sander or equivalent.

Installation Notes

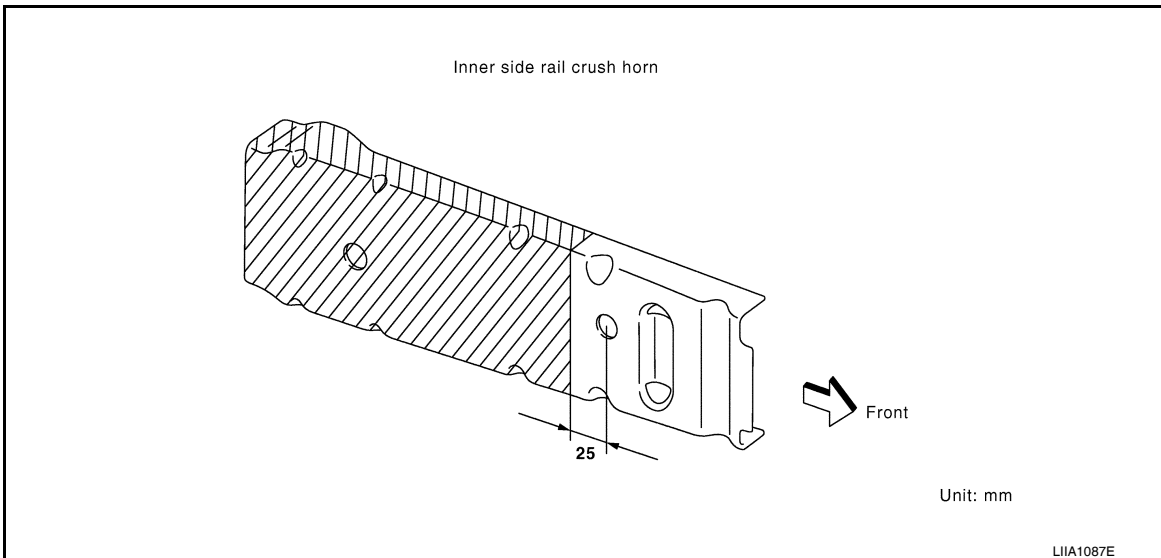

- Scribe a straight line on the inner side rail crush horn along the hole center as shown in the figure. Cut off inner side rail crush horn along scribed line.

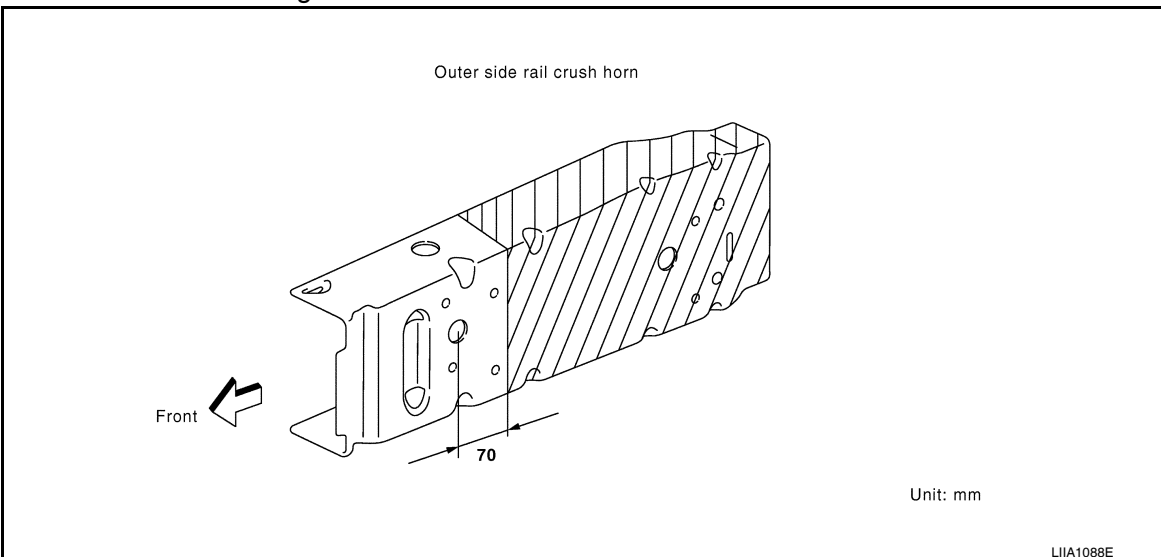

- Scribe a straight line on the outer side rail crush horn along the hole center as shown in the figure. Cut off outer side rail crush horn along scribed line.

REPLACEMENT OPERATIONS

< UNIT REMOVAL AND INSTALLATION >

- Weld part to be butt-welded and seam-welded corner to corner as shown in the figure.

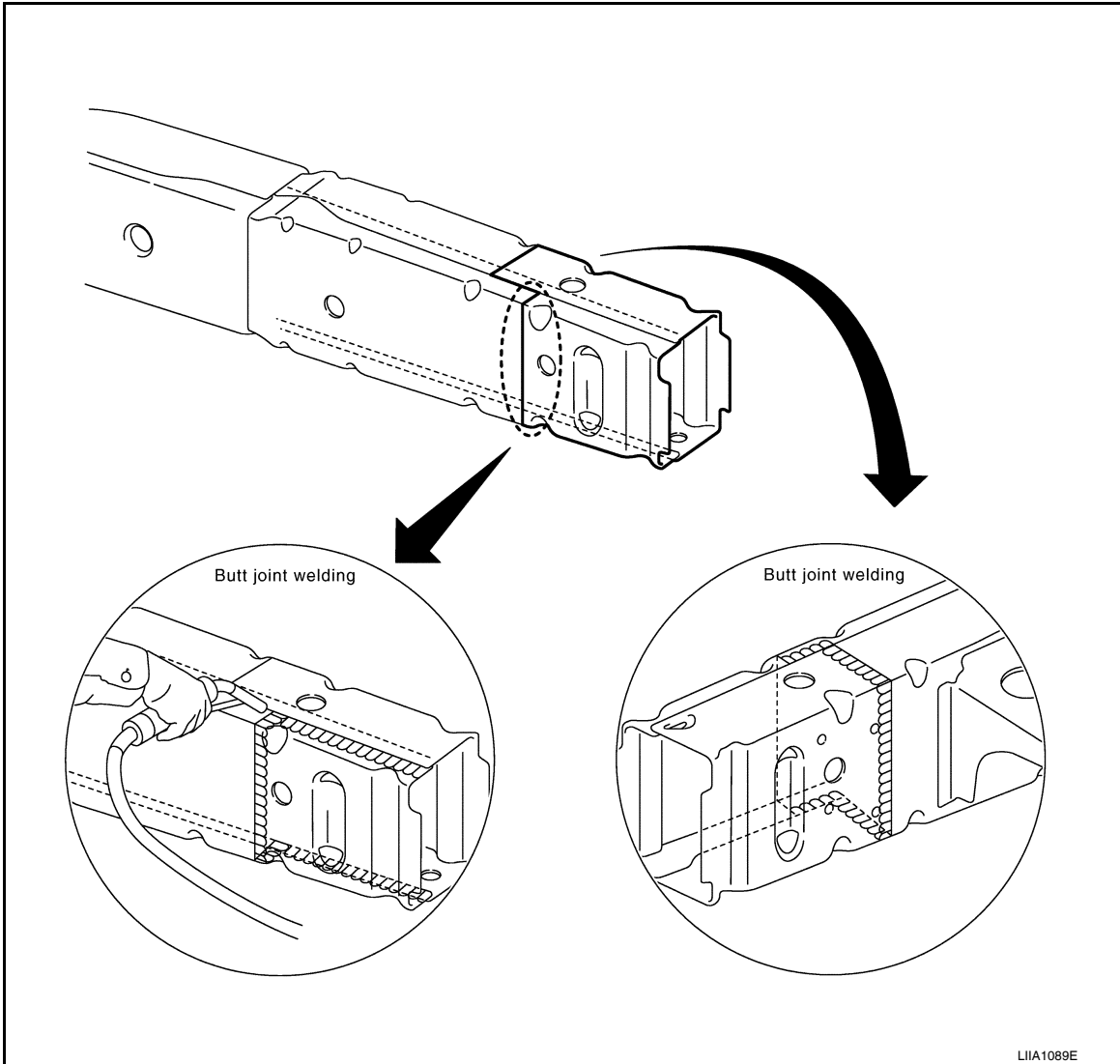

A
B
C
D
E
F
G
H
I
J

BRM

L
M
N
O
P