

SECTION **SR**  
SRS AIRBAG

A  
B  
C  
D  
E  
F  
G  
SR  
I  
J  
K  
L  
M  
N  
O  
P

CONTENTS

|  |   |  |    |
|--|---|--|----|
| <b>PRECAUTION</b> .....  | 2 | Removal and Installation .....                           | 8  |
| <b>PRECAUTIONS</b> .....   | 2 | <b>SIDE CURTAIN AIR BAG MODULE</b> .....                 | 11 |
| Precaution for Supplemental Restraint System (SRS) "AIR BAG" and "SEAT BELT PRE-TENSIONER" ..... | 2 | Removal and Installation .....                           | 11 |
| Precaution for SRS "AIR BAG" and "SEAT BELT PRE-TENSIONER" Service .....                         | 2 | <b>CRASH ZONE SENSOR</b> .....                           | 12 |
| Occupant Classification System Precaution .....  | 2 | Removal and Installation .....                           | 12 |
| <b>PREPARATION</b> .....   | 3 | <b>SIDE AIR BAG (SATELLITE) SENSOR</b> .....             | 13 |
| <b>PREPARATION</b> .....   | 3 | Removal and Installation .....                           | 13 |
| Special Service Tool .....   | 3 | <b>FRONT SEAT BELT PRE-TENSIONER</b> .....               | 14 |
| <b>REMOVAL AND INSTALLATION</b> .....  | 4 | Removal and Installation .....                           | 14 |
| <b>DRIVER AIR BAG MODULE</b> .....   | 4 | <b>DIAGNOSIS SENSOR UNIT</b> .....                       | 15 |
| Removal and Installation .....   | 4 | Removal and Installation .....                           | 15 |
| <b>SPIRAL CABLE</b> .....  | 6 | <b>OCCUPANT CLASSIFICATION SYSTEM CONTROL UNIT</b> ..... | 17 |
| Removal and Installation .....   | 6 | Removal and Installation .....                           | 17 |
| <b>FRONT PASSENGER AIR BAG MODULE</b> .....  | 8 | <b>COLLISION DIAGNOSIS</b> .....                         | 18 |
|  |   | For Frontal Collision .....                              | 18 |
|  |   | For Side and Rollover Collision .....                    | 20 |

# PRECAUTIONS

< PRECAUTION >

## PRECAUTION

### PRECAUTIONS

#### Precaution for Supplemental Restraint System (SRS) "AIR BAG" and "SEAT BELT PRE-TENSIONER"

INFOID:000000006163312

The Supplemental Restraint System such as "AIR BAG" and "SEAT BELT PRE-TENSIONER", used along with a front seat belt, helps to reduce the risk or severity of injury to the driver and front passenger for certain types of collision. This system includes seat belt switch inputs and dual stage front air bag modules. The SRS system uses the seat belt switches to determine the front air bag deployment, and may only deploy one front air bag, depending on the severity of a collision and whether the front occupants are belted or unbelted. Information necessary to service the system safely is included in the SR and SB section of this Service Manual.

#### **WARNING:**

- To avoid rendering the SRS inoperative, which could increase the risk of personal injury or death in the event of a collision which would result in air bag inflation, all maintenance must be performed by an authorized NISSAN/INFINITI dealer.
- Improper maintenance, including incorrect removal and installation of the SRS, can lead to personal injury caused by unintentional activation of the system. For removal of Spiral Cable and Air Bag Module, see the SR section.
- Do not use electrical test equipment on any circuit related to the SRS unless instructed to in this Service Manual. SRS wiring harnesses can be identified by yellow and/or orange harnesses or harness connectors.

#### PRECAUTIONS WHEN USING POWER TOOLS (AIR OR ELECTRIC) AND HAMMERS

#### **WARNING:**

- When working near the Airbag Diagnosis Sensor Unit or other Airbag System sensors with the Ignition ON or engine running, DO NOT use air or electric power tools or strike near the sensor(s) with a hammer. Heavy vibration could activate the sensor(s) and deploy the air bag(s), possibly causing serious injury.
- When using air or electric power tools or hammers, always switch the Ignition OFF, disconnect the battery, and wait at least 3 minutes before performing any service.

#### Precaution for SRS "AIR BAG" and "SEAT BELT PRE-TENSIONER" Service

INFOID:000000006163313

- Do not use electrical test equipment to check SRS circuits unless instructed to in this Service Manual.
- Before servicing the SRS, turn ignition switch OFF, disconnect both battery cables and wait at least 3 minutes.  
For approximately 3 minutes after the cables are removed, it is still possible for the air bags and seat belt pre-tensioners to deploy. Therefore, do not work on any SRS connectors or wires until at least 3 minutes have passed.
- The air bag diagnosis sensor unit must always be installed with the arrow mark "←" pointing toward the front of the vehicle for proper operation. Also check air bag diagnosis sensor unit for cracks, deformities or rust before installation and replace as required.
- The spiral cable must be aligned with the neutral position since its rotations are limited. Do not attempt to turn steering wheel or column after removal of steering gear.
- Handle air bag module carefully. Always place driver and front passenger air bag modules with the pad side facing upward and seat mounted front side air bag module standing with the stud bolt side facing down.
- Conduct self-diagnosis to check entire SRS for proper function after replacing any components.
- After air bag inflates, the front instrument panel assembly should be replaced if damaged.

#### Occupant Classification System Precaution

INFOID:000000006163314

Replace occupant classification system control unit and passenger front seat cushion as an assembly.

# PREPARATION

< PREPARATION >

## PREPARATION

### PREPARATION

#### Special Service Tool

INFOID:000000006163315

The actual shapes of Kent-Moore tools may differ from those of special service tools illustrated here.

| Tool number<br>(Kent-Moore No.)<br>Tool name                   | Description                          |
|--|--------------------------------------|
| —<br>(J-42057-UPD)<br>Air bag key set<br>Part of kit (J-42057) | Removing and installing air bag lock |

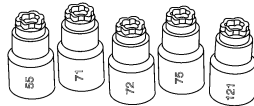

LRS210

A  
B  
C  
D  
E  
F  
G  
SR  
I  
J  
K  
L  
M  
N  
O  
P

# DRIVER AIR BAG MODULE

< REMOVAL AND INSTALLATION >

## REMOVAL AND INSTALLATION

### DRIVER AIR BAG MODULE

#### Removal and Installation

INFOID:000000006163316

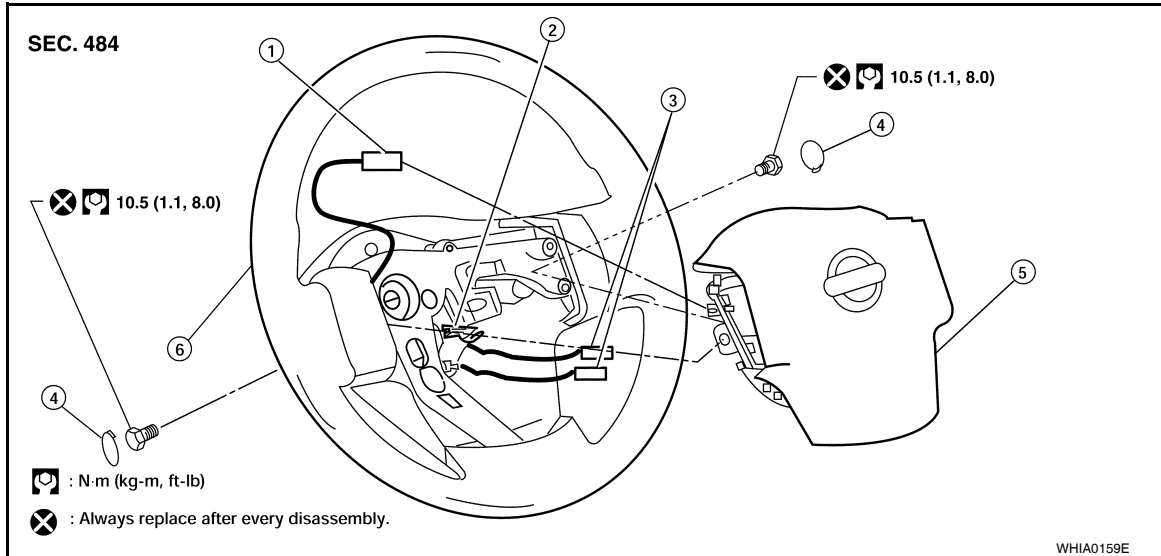

- |                    |                          |                     |
|--------------------|--------------------------|---------------------|
| 1. Horn harness    | 2. Steering wheel hook   | 3. Inflator harness |
| 4. Side lids RH/LH | 5. Driver air bag module | 6. Steering wheel   |

#### REMOVAL

##### CAUTION:

- Do not attempt to repair or replace damaged direct-connect SRS component connectors. If a driver air bag direct-connect harness connector is damaged, the spiral cable must be replaced.
- Before servicing the SRS, turn ignition switch OFF, disconnect both battery terminals and wait at least three minutes.
- When servicing the SRS, do not work from directly in front of air bag module.

1. Disconnect both the negative and positive battery terminals, then wait at least three minutes.
2. Remove the left and right side bolts.
3. Lift the driver air bag module from the steering wheel.
4. Disconnect the air bag harness and horn connectors, then remove the driver air bag module.

- For removal/installation of the direct-connect SRS connectors, refer to [SRC-9, "Direct-connect SRS Component Connectors"](#).

##### CAUTION:

- When servicing the SRS, do not work from directly in front of air bag module.
- Always place air bag module with pad side facing upward.
- Do not insert any foreign objects (screwdriver, etc.) into air bag module or harness connectors.
- Do not disassemble air bag module.
- Do not use old bolts after removal; replace with new bolts.
- Do not expose the air bag module to temperatures exceeding 90°C (194°F).

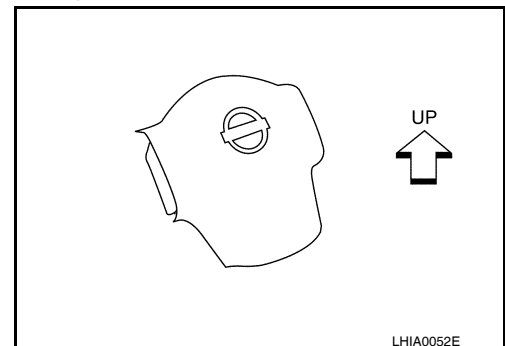

## DRIVER AIR BAG MODULE

### < REMOVAL AND INSTALLATION >

- Replace the air bag module if it has been dropped or sustained an impact.
- Do not allow oil, grease or water to come in contact with the air bag module.

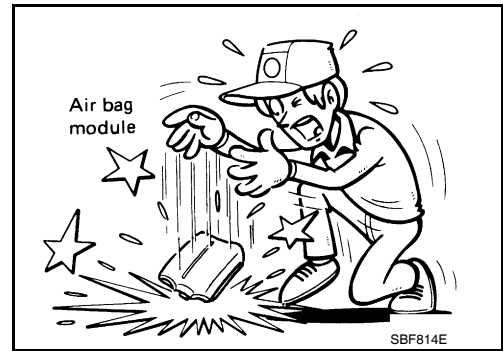

### INSTALLATION

Installation is in the reverse order of removal.

- If driver air bag module is being replaced due to deployment, spiral cable must also be replaced. Refer to [SR-6, "Removal and Installation"](#).
- For removal/installation of the direct-connect SRS connectors, refer to [SRC-9, "Direct-connect SRS Component Connectors"](#).
- After the work is completed, perform self-diagnosis to check that no malfunction is detected. Refer to [SRC-13, "SRS Operation Check"](#).

A  
B  
C  
D  
E  
F  
G  
SR  
I  
J  
K  
L  
M  
N  
O  
P

# SPIRAL CABLE

< REMOVAL AND INSTALLATION >

## SPIRAL CABLE

### Removal and Installation

INFOID:000000006163317

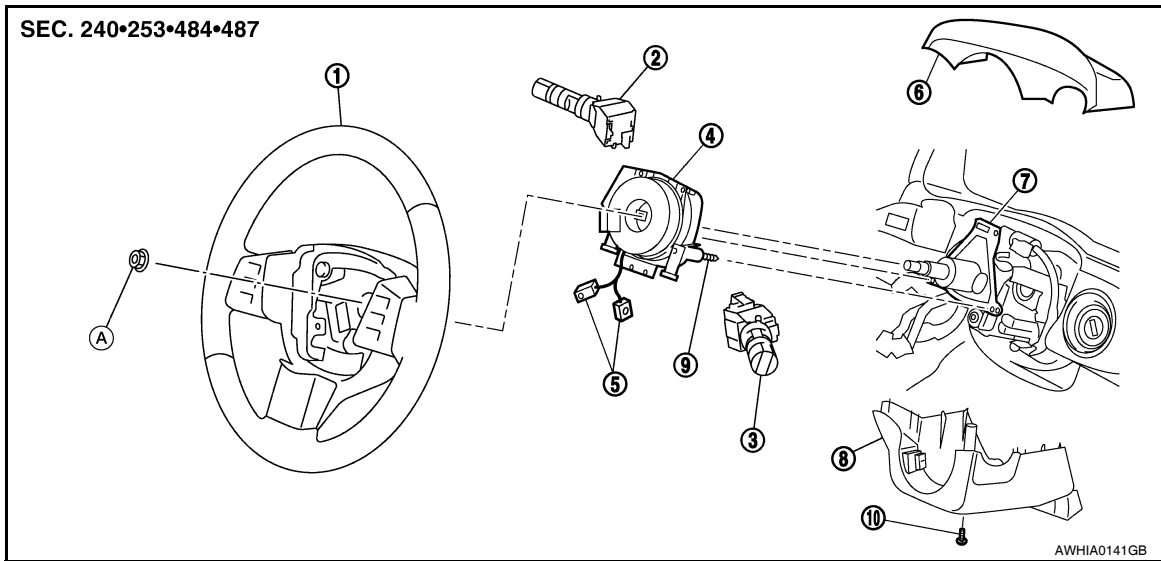

- |                    |   |                            |
|--------------------|---|----------------------------|
| 1. Steering wheel  | 2. Lighting and turn signal switch                            | 3. Wiper and washer switch |
| 4. Spiral cable    | 5. Driver air bag module connector                            | 6. Column cover upper      |
| 7. Column assembly | 8. Column cover lower   | 9. Screw (Do not remove)   |
| 10. Screw          | A. Refer to <a href="#">ST-11, "Removal and Installation"</a> |                            |

### REMOVAL

#### CAUTION:

• Before servicing the SRS, turn ignition switch OFF, disconnect both battery terminals and wait at least three minutes.

• When servicing the SRS, do not work from directly in front of air bag module.

1. Disconnect both the negative and positive battery terminals, then wait at least three minutes.
2. Remove the steering wheel. Refer to [ST-11, "Removal and Installation"](#).
3. Remove the instrument lower panel RH. Refer to [IP-17, "Removal and Installation"](#).
4. Remove the column cover upper and lower.
5. Remove wiper washer switch connector, then pinch the tabs at wiper and washer switch base and slide switch away from steering column to remove.

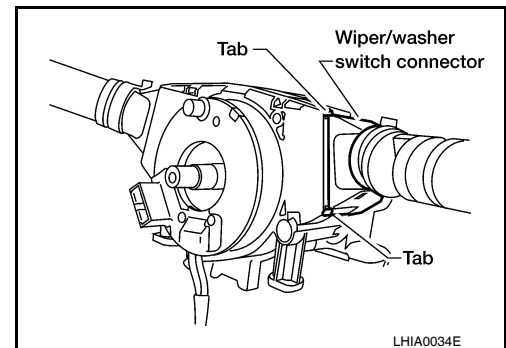

# SPIRAL CABLE

## < REMOVAL AND INSTALLATION >

6. While pressing tabs, pull lighting and turn signal switch toward driver door and disconnect from base.

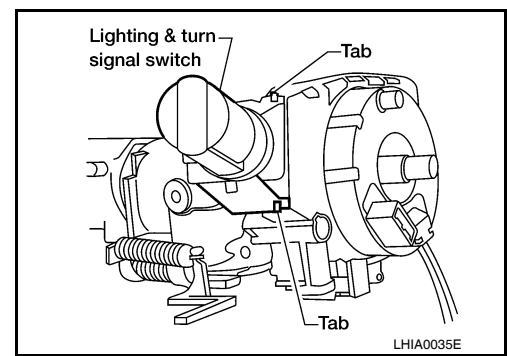

7. Remove the screws, release the clip, and remove the spiral cable.

**CAUTION:**

- Do not disassemble spiral cable.
- Do not apply lubricant to the spiral cable.

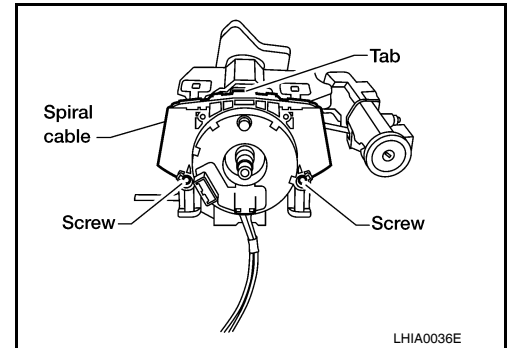

8. Remove the spiral cable connectors.

**CAUTION:**

With the steering linkage disconnected, the spiral cable may snap by turning the steering wheel beyond the limited number of turns. The spiral cable can be turned counterclockwise about 2.5 turns from the neutral position.

9. Remove the steering angle sensor from the spiral cable. Refer to [BRC-118. "Removal and Installation"](#).

## INSTALLATION

Installation is in the reverse order of removal.

- Align spiral cable correctly when installing steering wheel. Make sure that the spiral cable is in the neutral position. The neutral position is detected by turning left 2.5 revolutions from the right end position and ending with the knob at the top.
- Refer to [BRC-8. "ADJUSTMENT OF STEERING ANGLE SENSOR NEUTRAL POSITION : Special Repair Requirement"](#) for steering angle sensor adjustment.
- After the work is completed, perform self-diagnosis to make sure no malfunction is detected. Refer to [SRC-13. "SRS Operation Check"](#).

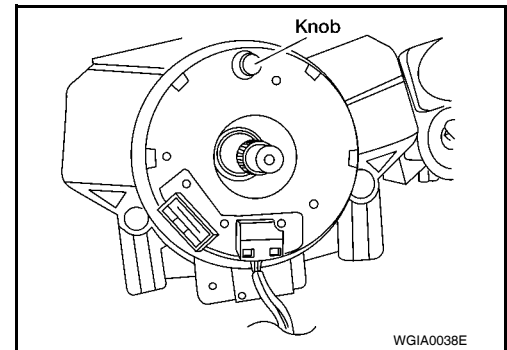

**CAUTION:**

- The spiral cable may snap due to steering operation if the cable is not installed in the correct position.
- With the steering linkage disconnected, the cable may snap by turning the steering wheel beyond the limited number of turns. The spiral cable can be turned counterclockwise about 2.5 turns from the neutral position.

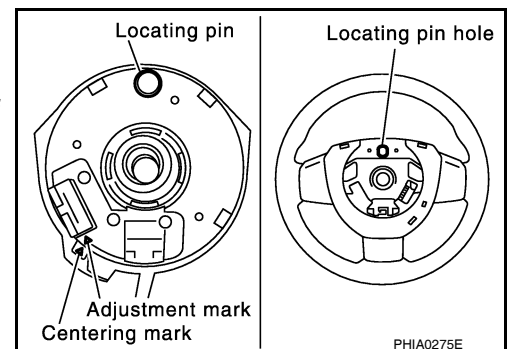

A  
B  
C  
D  
E  
F  
G  
SR  
I  
J  
K  
L  
M  
N  
O  
P

# FRONT PASSENGER AIR BAG MODULE

< REMOVAL AND INSTALLATION >

## FRONT PASSENGER AIR BAG MODULE

### Removal and Installation

INFOID:000000006163318

The passenger air bag module originally installed in the vehicle uses direct-connect style harness connectors. Service replacement passenger air bag modules use tab-locking style harness connectors. If the passenger air bag module is replaced or if the direct-connect harness connectors are damaged, the vehicle wiring harness must be modified to allow connection of the service replacement passenger air bag module. Follow the wiring harness modification procedure within this section.

#### REMOVAL

##### CAUTION:

- Do not attempt to repair or replace damaged direct-connect front passenger air bag module connectors. If a direct-connect harness connector is damaged, the front passenger air bag must be replaced and the wiring harness modified.
  - Before servicing SRS, turn the ignition switch off, disconnect both battery terminals and wait at least three minutes.
  - Always work from the side of or under front passenger air bag module.
1. Disconnect both the negative and positive battery terminals, then wait at least three minutes.
  2. Remove the glove box. Refer to [IP-16, "Removal and Installation"](#).
  3. Remove 2 nuts (through glove box opening) retaining front passenger air bag module to instrument panel crossmember.
  4. Disconnect the air bag module electrical connectors.
    - For removal/installation of the direct-connect SRS connectors, refer to [SRC-9, "Direct-connect SRS Component Connectors"](#).
  5. Remove the instrument panel assembly from the vehicle. Refer to [IP-12, "Removal and Installation"](#).
  6. Remove front passenger air bag module nuts and remove air bag module from the instrument panel assembly.

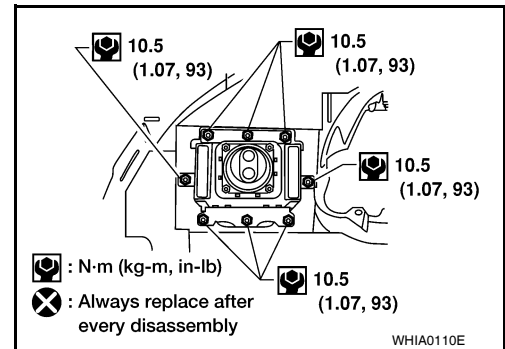

##### CAUTION:

- When servicing the SRS, do not work from directly in front of air bag module.
- Always place front passenger air bag module with caution label side facing upward.
- Do not insert any foreign objects (screwdriver, etc.) into air bag module or harness connectors.
- Do not disassemble air bag module.
- Do not use old nuts after removal; replace with new nuts.
- Do not expose the front passenger air bag module to temperatures exceeding 90°C (194°F).

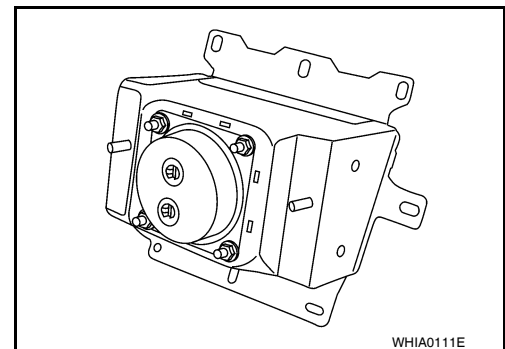

- Replace the air bag module if it has been dropped or sustained an impact.
- Do not allow oil, grease or water to come in contact with the air bag module.
- For removal/installation of the direct-connect SRS connectors, refer to [SRC-9, "Direct-connect SRS Component Connectors"](#).



#### INSTALLATION



# FRONT PASSENGER AIR BAG MODULE

## < REMOVAL AND INSTALLATION >

Original Passenger Air Bag Module

Installation is in the reverse order of removal.

- For removal/installation of the direct-connect SRS connectors, refer to [SRC-9, "Direct-connect SRS Component Connectors"](#).

### CAUTION:

- **Always work from the side of or under front passenger air bag module.**
- **After the work is completed, perform self-diagnosis to check that no malfunction is detected. Refer to [SRC-13, "SRS Operation Check"](#).**

Service Replacement Passenger Air Bag Module

1. Install the front passenger air bag module to the instrument panel pad assembly.

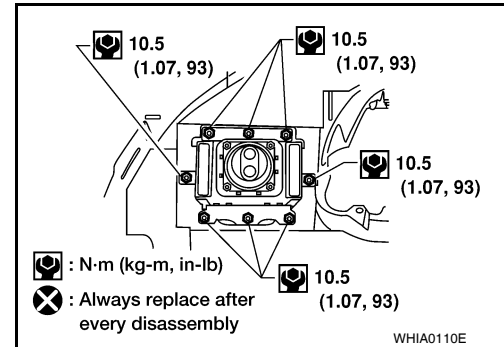

2. Install the instrument panel assembly. Refer to [IP-12, "Removal and Installation"](#).
3. Connect the front passenger air bag module harness connector to yellow 4-pin service replacement air bag connector and fasten connector to mounting bracket.

### CAUTION:

- **Always work from the side of or under front passenger air bag module.**
- **After the work is completed, perform self-diagnosis to check that no malfunction is detected. Refer to [SRC-13, "SRS Operation Check"](#).**

## WIRING HARNESS MODIFICATION

The passenger air bag module originally installed in the vehicle uses direct-connect style harness connectors. Service replacement passenger air bag modules use tab-locking style harness connectors. If the passenger air bag module is replaced or if the direct-connect harness connectors are damaged, the vehicle wiring harness must be modified to allow connection of the service replacement passenger air bag module.

### NOTE:

The wiring harness modification is to be performed only if the vehicle is equipped with the original passenger air bag which uses direct-connect harness connectors. If the passenger air bag is to be replaced in a vehicle that has already had the service replacement passenger air bag installed, the wiring harness modification is not required.

### CAUTION:

- **Do not attempt to repair or replace damaged direct-connect front passenger air bag module connectors. If a direct-connect harness connector is damaged, the front passenger air bag must be replaced and the wiring harness modified.**
- **Before servicing SRS, turn the ignition switch off, disconnect both battery cables and wait at least 3 minutes.**
- **Always work from the side of or under front passenger air bag module.**
- **After the work is completed, perform self-diagnosis to check that no malfunction is detected. Refer to [SRC-13, "SRS Operation Check"](#).**

1. Locate the yellow and orange direct-connect passenger air bag module harness connectors.
2. Use wire cutters to cut back both previously used direct-connect passenger air bag module harness connectors from the vehicle wiring harness approximately 50 mm (1.9 in) from the connectors.
3. Remove approximately 150 mm (5.9 in) of the vehicle harness covering from the cut end.

## FRONT PASSENGER AIR BAG MODULE

### < REMOVAL AND INSTALLATION >

- Slide a piece of dual-wall heat shrink tubing (provided in the passenger air bag service kit) onto each wire of the previously used vehicle wiring harness.

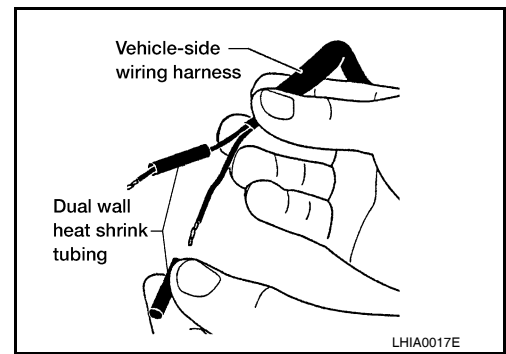

- Fold each wire back and insert into the end of the heat shrink tubing so that the end of the wire is approximately centered in the heat shrink tubing.

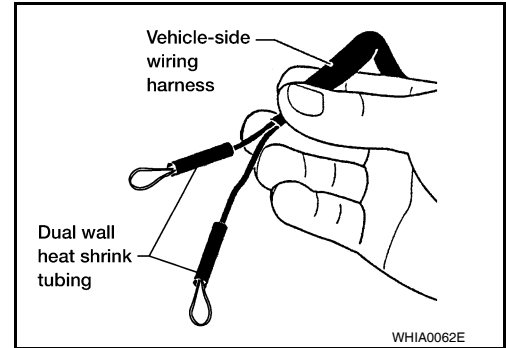

- Use a heat gun to shrink the heat shrink tubing and seal the wire.
- Use electrical tape to secure the modified circuits to the outside of the wiring harness.
- Locate the front passenger air bag service replacement connector that is taped back to the main harness. Unwrap the tape to access the yellow service replacement connector and remove the dust cover from the connector.

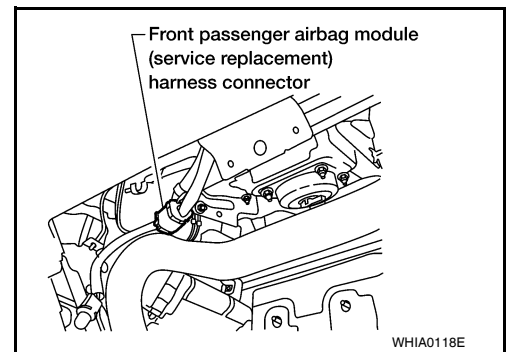

# SIDE CURTAIN AIR BAG MODULE

< REMOVAL AND INSTALLATION >

## SIDE CURTAIN AIR BAG MODULE

### Removal and Installation

INFOID:000000006163319

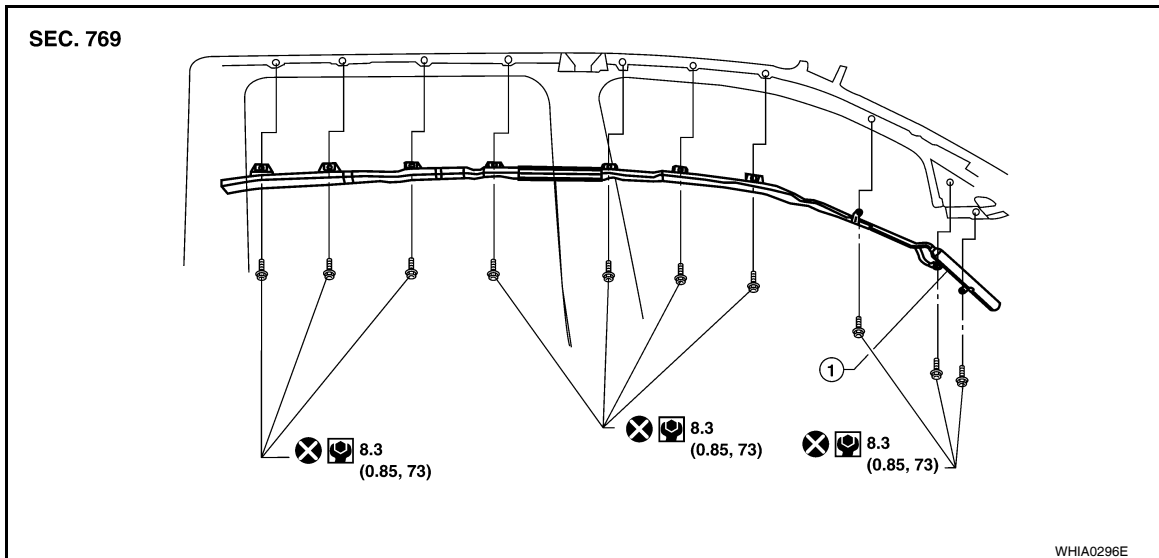

1. Side curtain airbag module connector

### REMOVAL

#### CAUTION:

- Do not attempt to repair or replace damaged direct-connect SRS component connectors. If a direct-connect harness connector is damaged, the harness must be replaced.
- Before servicing the SRS, turn the ignition switch off, disconnect both battery terminals and wait at least three minutes.
- When servicing the SRS, do not work from directly in front of air bag module.
- Do not insert any foreign objects (screwdriver, etc.) into air bag module or harness connectors.
- Do not disassemble air bag module.
- Do not expose the air bag module to temperatures exceeding 90°C (194°F).
- Replace side curtain air bag module if it has been dropped or sustained an impact.
- Do not allow oil, grease or water to come in contact with the air bag module.

1. Disconnect both the negative and positive battery terminals, then wait at least three minutes.
2. Remove headlining. Refer to [INT-21, "Removal and Installation"](#).
3. Disconnect side curtain air bag module connector.
  - For removal/installation of the direct-connect SRS connectors, refer to [SRC-9, "Direct-connect SRS Component Connectors"](#).
4. Remove the bolts in order starting at the front or rear, and remove the side curtain air bag module.

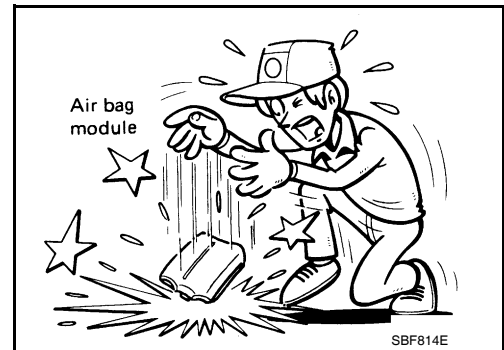

### INSTALLATION

Installation is in the reverse order of removal.

- For removal/installation of the direct-connect SRS connectors, refer to [SRC-9, "Direct-connect SRS Component Connectors"](#).
- After replacement of side curtain air bag module, perform self-diagnosis to check that no malfunction is detected. Refer to [SRC-13, "SRS Operation Check"](#).

A  
B  
C  
D  
E  
F  
G

SR

I  
J  
K  
L  
M  
N  
O

P

# CRASH ZONE SENSOR

< REMOVAL AND INSTALLATION >

## CRASH ZONE SENSOR

### Removal and Installation

INFOID:000000006163320

#### REMOVAL

##### CAUTION:

- Before servicing the SRS, turn the ignition switch off, disconnect both battery terminals and wait at least three minutes.

1. Disconnect both the negative and positive battery terminals, then wait at least three minutes.
2. Remove front grille. Refer to [EXT-19, "Removal and Installation"](#).
3. Disconnect the crash zone sensor harness connector.
4. Remove crash zone sensor nuts.

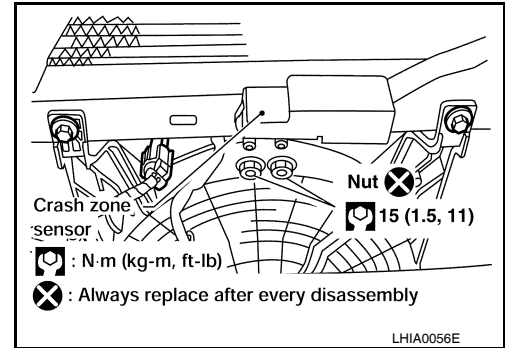

##### CAUTION:

- Replace crash zone sensor if it has been dropped or sustained an impact.
- Do not disassemble crash zone sensor.

#### INSTALLATION

Installation is in the reverse order of removal.

- After the work is complete, perform self-diagnosis to check that no malfunction is detected. Refer to [SRC-13, "SRS Operation Check"](#).

# SIDE AIR BAG (SATELLITE) SENSOR

< REMOVAL AND INSTALLATION >

## SIDE AIR BAG (SATELLITE) SENSOR

### Removal and Installation

INFOID:000000006163321

#### REMOVAL

##### CAUTION:

- Before servicing the SRS, turn the ignition switch off, disconnect both battery terminals and wait at least three minutes.

1. Disconnect both the negative and positive battery terminals, then wait at least three minutes.
2. For crew cab models, remove seat belt retractor assembly. Refer to [SB-4, "Removal and Installation of Front Seat Belt"](#). For king cab models, remove kicking plates and pull back carpet.
3. Remove side air bag (satellite) sensor nuts.
4. Disconnect the side air bag (satellite) sensor harness connector.

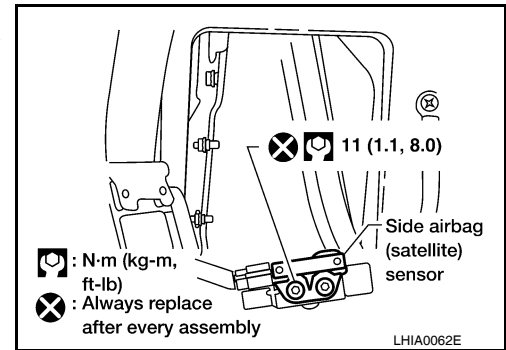

##### CAUTION:

- Do not use old nuts after removal; replace with new nuts.
- Check side air bag (satellite) sensor to ensure it is free of deformities, dents, cracks or rust. If it shows any visible signs of damage, replace it with new one.
- Do not disassemble side air bag (satellite) sensor.
- Replace side air bag (satellite) sensor if it has been dropped or sustained an impact.

#### INSTALLATION

Installation is in the reverse order of removal.

- After the work is completed, perform self-diagnosis to check that no malfunction is detected. Refer to [SRC-13, "SRS Operation Check"](#).

## FRONT SEAT BELT PRE-TENSIONER

< REMOVAL AND INSTALLATION >

---

### FRONT SEAT BELT PRE-TENSIONER

#### Removal and Installation

INFOID:000000006163322

For removal and installation procedures for seat belt and seat belt buckle pre-tensioners, refer to [SB-4, "Removal and Installation of Front Seat Belt"](#).

# DIAGNOSIS SENSOR UNIT

< REMOVAL AND INSTALLATION >

## DIAGNOSIS SENSOR UNIT

### Removal and Installation

INFOID:000000006163323

#### REMOVAL

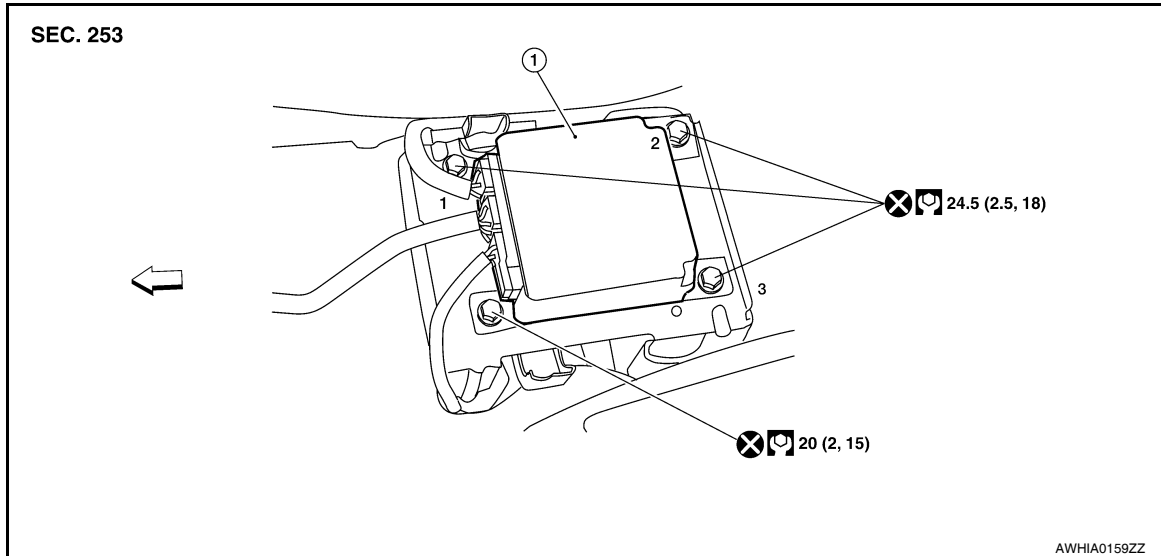

1. Diagnosis sensor unit

← Vehicle front

#### CAUTION:

- Before servicing the SRS, turn the ignition switch off, disconnect both battery terminals and wait at least three minutes.
- Do not use old bolts; replace with new bolts.
- Check diagnosis sensor unit bracket to make sure it is free of deformities, dents, cracks or rust. If it shows any visible signs of damage, replace with new one.
- Replace diagnosis sensor unit if it has been dropped or sustained an impact.
- Never use air tools or electric tools for servicing.
- When replacing the air bag diagnosis sensor unit, always check with the parts department for the latest parts information. Installing an incorrect air bag diagnosis sensor unit may or may not cause the air bag warning lamp to illuminate and may cause incorrect deployment of the supplemental air bags and seat belt pre-tensioner in a collision resulting in serious personal injury or death.

1. Always check the air bag diagnosis sensor unit ECU discriminated number (identification number) using CONSULT-III.
2. Disconnect the negative and positive battery terminals, then wait at least three minutes.
3. Disconnect the harness connectors for the following SRS components: [SR-11. "Removal and Installation"](#) (Side curtain air bag module), [SE-44. "Disassembly and Assembly"](#) (Side air bag module), [SB-4. "Removal and Installation of Front Seat Belt"](#) (Seat belt pre-tensioner).
4. Remove center console. Refer to [IP-19. "Removal and Installation"](#).
5. Disconnect diagnosis sensor unit harness connectors.
6. Remove bolts from the diagnosis sensor unit.

#### CAUTION:

- Do not use old bolts; replace with new bolts.
- Check diagnosis sensor unit bracket to ensure it is free of deformities, dents, cracks or rust. If it shows any visible signs of damage, replace with new one.
- Replace diagnosis sensor unit if it has been dropped or sustained an impact.

#### INSTALLATION

Installation is in the reverse order of removal.

- Always follow the tightening sequence shown.

## DIAGNOSIS SENSOR UNIT

### < REMOVAL AND INSTALLATION >

---

- After the work is completed, perform self-diagnosis to check that no malfunction is detected. Refer to [SRC-13, "SRS Operation Check"](#).

#### **CAUTION:**

- The diagnosis sensor unit must always be installed with the arrow mark "←" pointing toward the front of the vehicle for proper operation.
- When installing diagnosis sensor unit bolt, use proper tightening sequence.
- Never damage the harness while installing.
- If malfunction is detected by the air bag warning lamp after repair or replacement of the malfunctioning parts, reset the memory using self-diagnosis or CONSULT-III. Refer to [SRC-15, "Self-Diagnosis Function \(Without CONSULT-III\)"](#).
- After the work is completed, check that no system malfunction is detected by air bag warning lamp.
- After replacing the air bag diagnosis sensor unit, confirm using CONSULT-III that the ECU discriminated number (identification number) of the new replacement air bag diagnosis sensor unit matches the ECU discriminated number (identification number) of the replaced (old) air bag diagnosis sensor unit.

#### **NOTE:**

If the ECU discriminated number of the new replacement air bag diagnosis sensor unit differs from the ECU discriminated number of the replaced air bag diagnosis sensor unit, reconfirm the parts information and verify that the correct air bag diagnosis sensor unit was installed.



# OCCUPANT CLASSIFICATION SYSTEM CONTROL UNIT

< REMOVAL AND INSTALLATION >

## OCCUPANT CLASSIFICATION SYSTEM CONTROL UNIT

### Removal and Installation

INFOID:000000006163324

The occupant classification system control unit, occupant classification (pressure) sensor, and bladder are an integral part of the front passenger seat cushion and are replaced as an assembly. Refer to [SE-30, "Removal and Installation For Front Seat"](#) to remove the seat, and [SE-44, "Disassembly and Assembly"](#) to replace the seat cushion.

A  
B  
C  
D  
E  
F  
G  
SR  
I  
J  
K  
L  
M  
N  
O  
P

# COLLISION DIAGNOSIS

< REMOVAL AND INSTALLATION >

## COLLISION DIAGNOSIS

### For Frontal Collision

INFOID:000000006163325

FOR FRONTAL COLLISION: When SRS is activated in a collision

**CAUTION:**

**Due to varying models and option levels, not all parts listed in the chart below apply to all vehicles.**

**WORK PROCEDURE**

1. Before performing any of the following steps, ensure that all vehicle body and structural repairs have been completed.
2. Replace the diagnosis sensor unit.
3. Remove the front air bag modules, crash zone sensor assembly, bracket and seat belt pre-tensioner assemblies.
4. Check the SRS components using the table below:  
Replace any SRS components showing visible signs of damage. (dents, cracks and deformation, etc.)
5. Install new front air bag modules, crash zone sensor assembly, bracket and seat belt pre-tensioner assemblies.
6. Perform self-diagnosis using CONSULT-III or air bag warning lamp. Refer to [SRC-15, "Self-Diagnosis Function \(Without CONSULT-III\)"](#) for details.  
Ensure entire SRS operates properly.
7. After the work is completed, perform self-diagnosis to check that no malfunction is detected. Refer to [SRC-13, "SRS Operation Check"](#).

**SRS INSPECTION (FOR FRONTAL COLLISION)**

| Part  | Inspection  |
|---|---|
| Driver air bag module   | If the driver air bag has deployed:<br>REPLACE<br>Install with new fasteners.   |
| Front passenger air bag module (if equipped)  | If the front passenger air bag has deployed:<br>REPLACE<br>Install with new fasteners.  |
| Crash zone sensor   | If any of the front air bags or seat belt pre-tensioners* have been activated:<br>REPLACE the crash zone sensor and bracket with new fasteners.<br>*: Confirm seat belt pre-tensioner activation using CONSULT-III only.  |
| Seat belt pre-tensioner assemblies (All applicable locations: buckle, retractor, lap outer) | If either the driver or passenger seat belt pre-tensioner* has been activated:<br>REPLACE all seat belt pre-tensioner assemblies with new fasteners.<br>*: Confirm seat belt pre-tensioner activation using CONSULT-III only.   |
| Diagnosis sensor unit   | If any of the SRS components have been activated:<br>REPLACE the diagnosis sensor unit.<br>Install with new fasteners.  |
| Steering wheel  | <ol style="list-style-type: none"> <li>1. Visually check steering wheel for deformities.</li> <li>2. Check harness (built into steering wheel) and connectors for damage, and terminals for deformities.</li> <li>3. Install driver air bag module into the steering wheel to check fit and alignment with the wheel.</li> <li>4. Check steering wheel for excessive free play.</li> <li>5. If no damage is found, reinstall.</li> <li>6. If damaged—REPLACE.</li> </ol>            |
| Spiral cable  | If the driver front air bag has deployed:<br>REPLACE the spiral cable.  |
| Occupant classification system (Passenger seat)   | <ol style="list-style-type: none"> <li>1. Remove passenger seat assembly.</li> <li>2. Check control unit case for dents, cracks or deformities.</li> <li>3. Check connectors and pressure sensor tube for damage, and terminals for deformities.</li> <li>4. Check seat frame and cushion pan for dents or deformities.</li> <li>5. If no damage is found, reinstall seat with new fasteners.</li> <li>6. If damaged — REPLACE seat cushion assembly with new fasteners.</li> </ol> |

# COLLISION DIAGNOSIS

## < REMOVAL AND INSTALLATION >

| Part                      | Inspection   |
|---------------------------|--|
| Harness and connectors    | <ol style="list-style-type: none"> <li>1. Check connectors for poor connection, damage, and terminals for deformities.</li> <li>2. Check harness for binding, chafing, cuts, or deformities.</li> <li>3. If no damage is found, reinstall the harness and connectors.</li> <li>4. If damaged—REPLACE the damaged harness. Do not attempt to repair, splice or modify any SRS harness.</li> </ol> |
| Instrument panel assembly | If the passenger front air bag has deployed:<br>REPLACE the instrument panel assembly. (integrated type)   |

FOR FRONTAL COLLISION: When SRS is not activated in a collision

### CAUTION:

**Due to varying models and option levels, not all parts listed in the chart below apply to all vehicles.**

#### WORK PROCEDURE

1. Before performing any of the following steps, ensure that all vehicle body and structural repairs have been completed.
2. Check the SRS components using the table below:  
Replace any SRS components showing visible signs of damage. (dents, cracks and deformation, etc.)
3. Perform self-diagnosis using CONSULT-III or air bag warning lamp. Refer to [SRC-15. "Self-Diagnosis Function \(Without CONSULT-III\)"](#) for details.  
Ensure entire SRS operates properly.
4. After the work is completed, perform self-diagnosis to check that no malfunction is detected. Refer to [SRC-13. "SRS Operation Check"](#).

#### SRS INSPECTION (FOR FRONTAL COLLISION)

| Part  | Inspection  |
|---|---|
| Driver air bag module   | If the driver air bag has NOT been activated: <ol style="list-style-type: none"> <li>1. Remove driver air bag module. Check harness cover and connectors for damage, terminals for deformities, and harness for binding.</li> <li>2. Install driver air bag module into the steering wheel to check fit and alignment with the wheel.</li> <li>3. If no damage is found, reinstall with new fasteners.</li> <li>4. If damaged—REPLACE. Install driver air bag modules with new fasteners.</li> </ol>  |
| Front passenger air bag module (if equipped)  | If the front passenger air bag has NOT been activated: <ol style="list-style-type: none"> <li>1. Remove front passenger air bag module. Check harness cover and connectors for damage, terminals for deformities, and harness for binding.</li> <li>2. Install front passenger air bag module into the instrument panel to check fit with the instrument panel.</li> <li>3. If no damage is found, reinstall with new fasteners.</li> <li>4. If damaged—REPLACE. Install front passenger air bag modules with new fasteners.</li> </ol>   |
| Crash zone sensor   | If the front air bags or seat belt pre-tensioners have NOT been activated: <ol style="list-style-type: none"> <li>1. Remove the crash zone sensor. Check harness connectors for damage, terminals for deformities, and harness for binding.</li> <li>2. Check for visible signs of damage (dents, cracks, deformation) of the crash zone sensor and bracket.</li> <li>3. Install the crash zone sensor to check fit.</li> <li>4. If no damage is found, reinstall with new fasteners.</li> <li>5. If damaged—REPLACE the crash zone sensor and bracket with new fasteners.</li> </ol>   |
| Seat belt pre-tensioner assemblies (All applicable locations: buckle, retractor, lap outer) | If the pre-tensioners have NOT been activated: <ol style="list-style-type: none"> <li>1. Remove seat belt pre-tensioners.<br/>Check harness cover and connectors for damage, terminals for deformities, and harness for binding.</li> <li>2. Check belts for damage and anchors for loose mounting.</li> <li>3. Check retractor for smooth operation.</li> <li>4. Check seat belt adjuster for damage.</li> <li>5. Check for deformities of the center pillar inner.</li> <li>6. If the center pillar inner has no damage, REPLACE the seat belt pre-tensioner assembly.</li> <li>7. If no damage is found, reinstall seat belt pre-tensioner assembly.</li> <li>8. If damaged—REPLACE. Install the seat belt pre-tensioners with new fasteners.</li> </ol> |

# COLLISION DIAGNOSIS

## < REMOVAL AND INSTALLATION >

| Part  | Inspection  |
|---|---|
| Diagnosis sensor unit                           | If none of the SRS components have been activated:<br>1. Check case for dents, cracks or deformities.<br>2. Check connectors for damage, and terminals for deformities.<br>3. If no damage is found, reinstall with new fasteners.<br>4. If damaged—REPLACE. Install diagnosis sensor unit with new fasteners.  |
| Steering wheel                                  | 1. Visually check steering wheel for deformities.<br>2. Check harness (built into steering wheel) and connectors for damage, and terminals for deformities.<br>3. Install driver air bag module into the steering wheel to check fit and alignment with the wheel.<br>4. Check steering wheel for excessive free play.<br>5. If no damage is found, reinstall.<br>6. If damaged—REPLACE.            |
| Spiral cable                                    | If the driver front air bag has not deployed:<br>1. Visually check spiral cable and combination switch for damage.<br>2. Check connectors and protective tape for damage.<br>3. Check steering wheel for noise, binding or heavy operation.<br>4. If no damage is found, reinstall.<br>5. If damaged—REPLACE.   |
| Occupant classification system (Passenger seat) | 1. Remove passenger seat assembly.<br>2. Check control unit case for dents, cracks or deformities.<br>3. Check connectors and pressure sensor tube for damage, and terminals for deformities.<br>4. Check seat frame and cushion pan for dents or deformities.<br>5. If no damage is found, reinstall seat with new fasteners.<br>6. If damaged — REPLACE seat cushion assembly with new fasteners. |
| Harness and connectors                          | 1. Check connectors for poor connection, damage, and terminals for deformities.<br>2. Check harness for binding, chafing, cuts, or deformities.<br>3. If no damage is found, reinstall the harness and connectors.<br>4. If damaged—REPLACE the damaged harness. Do not attempt to repair, splice or modify any SRS harness.  |
| Instrument panel assembly                       | If the passenger front air bag has NOT deployed:<br>1. Visually check instrument panel for damage.<br>2. If no damage is found, reinstall the instrument panel assembly.<br>3. If damaged—REPLACE the instrument panel assembly.  |

## For Side and Rollover Collision

INFOID:000000006163326

FOR SIDE AND ROLLOVER COLLISION: When SRS is activated in a collision

### **CAUTION:**

**Due to varying models and option levels, not all parts listed in the chart below apply to all vehicles.**

### WORK PROCEDURE

1. Before performing any of the following steps, ensure that all vehicle body and structural repairs have been completed.
2. Replace the following components:
  - Front seat back assembly (on the side on which side air bag is activated).
  - Door finisher (on the side on which door-mounted curtain air bag is activated).
  - Pop-up roll bar assemblies and pop-up roll bar covers.
  - Side air bag (satellite) sensor LH/RH (on the side on which side air bag is activated).
  - Diagnosis sensor unit.
  - Seat belt pre-tensioner assemblies.
3. Check the SRS components and the related parts using the following table. Replace any SRS components and the related parts showing visible signs of damage (dents, cracks, deformation, etc.).
4. Perform self-diagnosis using CONSULT-III and "AIR BAG" warning lamp. Refer to [SRC-13, "SRS Operation Check"](#) for details. Make sure entire SRS operates properly.
5. After the work is completed, perform self-diagnosis to check that no malfunction is detected. Refer to [SRC-15, "Self-Diagnosis Function \(Without CONSULT-III\)"](#).

### SRS INSPECTION (FOR SIDE AND ROLLOVER COLLISION)

# COLLISION DIAGNOSIS

## < REMOVAL AND INSTALLATION >

| Part   | Inspection  | A  |
|--|---|----|
| Side curtain air bag module LH   | If the side curtain air bag LH has deployed:<br>REPLACE the side curtain air bag module LH.<br>Install with new fasteners.  | B  |
| Side curtain air bag module RH   | If the side curtain air bag RH has deployed:<br>REPLACE the side curtain air bag module RH.<br>Install with new fasteners.  | C  |
| Front side air bag module LH   | If the front side air bag LH has deployed:<br>REPLACE front seatback assembly LH.   | D  |
| Front side air bag module RH   | If the front side air bag RH has deployed:<br>REPLACE front seatback assembly RH.   | E  |
| Side air bag (satellite) sensor (LH or RH)   | If any of the SRS components have deployed:<br>REPLACE the side air bag (satellite) sensor on the collision side with new fasteners.  | F  |
| Diagnosis sensor unit  | If any of the SRS components have deployed:<br>REPLACE the diagnosis sensor unit with new fasteners.  | G  |
| Seat belt pre-tensioner assemblies<br>(All applicable locations: buckle, retractor, lap outer) | If either the driver or passenger seat belt pre-tensioner* has been activated:<br>REPLACE all seat belt pre-tensioner assemblies with new fasteners.<br>*: Confirm seat belt pre-tensioner activation using CONSULT-III only. | H  |
| Center inner pillar  | 1. Check the center inner pillar on the collision side for damage (dents, cracks, deformation).<br>2. If damaged—REPAIR the center inner pillar.  | I  |
| Seat (if equipped with front side air bag)   | If either the front LH or front RH side air bag modules has been deployed:<br>REPLACE front seatback assembly on the deployed side.   | SR |
| Trim/headlining  | 1. Check for visible signs of damage (dents, cracks, deformation) of the interior trim on the collision side.<br>2. If damaged—REPLACE the damaged trim parts.  | J  |
| Door-mounted curtain air bag module LH   | If the door-mounted curtain air bag module LH has been deployed:<br>REPLACE the door finisher LH and door-mounted curtain air bag module.<br>Install with new fasteners.  | K  |
| Door-mounted curtain air bag module RH   | If the door-mounted curtain air bag module RH has been deployed:<br>REPLACE the door finisher RH and door-mounted curtain air bag module.<br>Install with new fasteners.  | L  |
| Pop-up roll bar assemblies   | If the pop-up roll bar has deployed:<br>REPLACE pop-up roll bar assemblies and pop-up roll bar covers.<br>Install with new fasteners.   | M  |

FOR SIDE AND ROLLOVER COLLISION: When SRS is not activated in a collision

**CAUTION:**

**Due to varying models and option levels, not all parts listed in the chart below apply to all vehicles.**

**WORK PROCEDURE**

1. Before performing any of the following steps, ensure that all vehicle body and structural repairs have been completed.
2. Check the SRS components and the related parts using the following table.
  - If the front seat back assembly is damaged, the front seat back assembly must be replaced.
  - If the door finisher assembly is damaged, the door finisher assembly and door-mounted curtain air bag module must be replaced.
3. Perform self-diagnosis using CONSULT-III and "AIR BAG" warning lamp. Refer to [SRC-13. "SRS Operation Check"](#) for details. Make sure entire SRS operates properly.
4. After the work is completed, perform self-diagnosis to check that no malfunction is detected. Refer to [SRC-15. "Self-Diagnosis Function \(Without CONSULT-III\)"](#).

**SRS INSPECTION (FOR SIDE AND ROLLOVER COLLISION)**

# COLLISION DIAGNOSIS

## < REMOVAL AND INSTALLATION >

| Part   | Inspection   |
|--|--|
| Side curtain air bag module LH   | <p>If the side curtain air bag LH has NOT deployed:</p> <ol style="list-style-type: none"> <li>1. Check for visible signs of damage (dents, tears, deformation) of the center pillar on the collision side.</li> <li>2. If damaged—Remove the side curtain air bag module LH.</li> <li>3. Check for visible signs of damaged (tears etc.) of the side curtain air bag module LH.</li> <li>4. Check harness and connectors for damage, and terminals for deformities.</li> <li>5. If no damage is found, reinstall the side curtain air bag module LH with new fasteners.</li> <li>6. If damaged—REPLACE the side curtain air bag module LH with new fasteners.</li> </ol>  |
| Side curtain air bag module RH   | <p>If the side curtain air bag RH has NOT deployed:</p> <ol style="list-style-type: none"> <li>1. Check for visible signs of damage (dents, tears, deformation) of the center pillar on the collision side.</li> <li>2. If damaged—Remove the side curtain air bag module RH.</li> <li>3. Check for visible signs of damaged (tears etc.) of the side curtain air bag module RH.</li> <li>4. Check harness and connectors for damage, and terminals for deformities.</li> <li>5. If no damage is found, reinstall the side curtain air bag module RH with new fasteners.</li> <li>6. If damaged—REPLACE the side curtain air bag module RH with new fasteners.</li> </ol>  |
| Front side air bag module LH   | <p>If the front LH side air bag has NOT deployed:</p> <ol style="list-style-type: none"> <li>1. Check for visible signs of damage (dents, tears, deformation) of the seat back on the collision side.</li> <li>2. Check harness and connectors for damage, and terminals for deformities.</li> <li>3. If damaged—REPLACE the front seatback assembly LH.</li> </ol>  |
| Front side air bag module RH   | <p>If the front side air bag RH has NOT deployed:</p> <ol style="list-style-type: none"> <li>1. Check for visible signs of damage (dents, tears, deformation) of the seat back on the collision side.</li> <li>2. Check harness and connectors for damage, and terminals for deformities.</li> <li>3. If damaged—REPLACE the front seatback assembly RH.</li> </ol>  |
| Side air bag (satellite) sensor (LH or RH)   | <p>If none of the SRS components have been activated:</p> <ol style="list-style-type: none"> <li>1. Remove the side air bag (satellite) sensor (LH or RH) on the collision side. Check harness connectors for damage, terminals for deformities, and harness for binding.</li> <li>2. Check for visible signs of damage (dents, cracks, deformation) of the side air bag (satellite) sensor (LH or RH).</li> <li>3. Install the side air bag (satellite) sensor (LH or RH) to check fit.</li> <li>4. If no damage is found, reinstall the side sir bag (satellite) sensor (LH or RH) with new fasteners.</li> <li>5. If damaged—REPLACE the side air bag (satellite) sensor (LH or RH) with new fasteners.</li> </ol>  |
| Diagnosis sensor unit  | <p>If none of the SRS components have been activated:</p> <ol style="list-style-type: none"> <li>1. Check case and bracket for dents, cracks or deformities.</li> <li>2. Check connectors for damage, and terminals for deformities.</li> <li>3. If no damage is found, reinstall the diagnosis sensor unit with new fasteners.</li> <li>4. If damaged—REPLACE the diagnosis sensor unit with new fasteners.</li> </ol>  |
| Seat belt pre-tensioner assemblies<br>(All applicable locations: buckle, retractor, lap outer) | <p>If the pre-tensioners have NOT been activated:</p> <ol style="list-style-type: none"> <li>1. Remove seat belt pre-tensioners.<br/>Check harness cover and connectors for damage, terminals for deformities, and harness for binding.</li> <li>2. Check belts for damage and anchors for loose mounting.</li> <li>3. Check retractor for smooth operation.</li> <li>4. Check seat belt adjuster for damage.</li> <li>5. Check for deformities of the center pillar inner.</li> <li>6. If the center pillar inner has no damage, REPLACE the seat belt pre-tensioner assembly.</li> <li>7. If no damage is found, reinstall seat belt pre-tensioner assembly.</li> <li>8. If damaged—REPLACE. Install the seat belt pre-tensioners with new fasteners.</li> </ol> |
| Seat (with front side air bag)   | <p>If the front LH or front RH side air bag modules have NOT deployed:</p> <ol style="list-style-type: none"> <li>1. Visually check the seat on the collision side.</li> <li>2. Remove the seat on the collision side and check the following for damage and deformities. <ul style="list-style-type: none"> <li>- Harness, connectors and terminals</li> <li>- Frame and recliner (for front and rear seat), and also adjuster and slides (for front seat)</li> </ul> </li> <li>3. If no damage is found, reinstall the seat.</li> <li>4. If damaged—REPLACE the damaged seat parts using new fasteners. If the front seat back is damaged, the front seat back assembly must be replaced.</li> </ol>   |

# COLLISION DIAGNOSIS

## < REMOVAL AND INSTALLATION >

| Part                                   | Inspection   |                  |
|--|--|------------------|
| Center inner pillar                    | <ol style="list-style-type: none"> <li>1. Check the center inner pillar on the collision side for damage (dents, cracks, deformation, etc.).</li> <li>2. If damaged - REPAIR the center inner pillar.</li> </ol>   | A                |
| Trim/headlining                        | <ol style="list-style-type: none"> <li>1. Check for visible signs of damage (dents, cracks, deformation, etc.) of the interior trim on the collision side.</li> <li>2. If damaged - REPLACE the damaged trim parts.</li> </ol>   | B                |
| Door-mounted curtain air bag module LH | <p>If the door-mounted curtain air bag LH has NOT deployed:</p> <ol style="list-style-type: none"> <li>1. Check for visible signs of damage (dents tears, deformation, etc.) of the door finisher on the collision side.</li> <li>2. If damaged - REPLACE the door finisher LH with new fasteners.</li> <li>3. Check for visible signs of damaged (dents etc.) of the door-mounted curtain air bag module LH.</li> <li>4. Check harness and connectors for damage, and terminals for deformities.</li> <li>5. If no damage is found, reinstall door finisher.</li> </ol> <p><b>CAUTION:</b><br/>When removing door mounted curtain air bag module from door finisher, never reuse door finisher.</p> <ol style="list-style-type: none"> <li>6. If damaged - REPLACE the door finisher LH and door-mounted curtain air bag module LH with new fasteners.</li> </ol> | C<br>D<br>E<br>F |
| Door-mounted curtain air bag module RH | <p>If the door-mounted curtain air bag RH has NOT deployed:</p> <ol style="list-style-type: none"> <li>1. Check for visible signs of damage (dents tears, deformation, etc.) of the door finisher on the collision side.</li> <li>2. If damaged - REPLACE the door finisher RH with new fasteners.</li> <li>3. Check for visible signs of damaged (tears etc.) of the door-mounted curtain air bag module RH.</li> <li>4. Check harness and connectors for damage, and terminals for deformities.</li> <li>5. If no damage is found, reinstall door finisher.</li> </ol> <p><b>CAUTION:</b><br/>When removing door mounted curtain air bag module from door finisher, never reuse door finisher.</p> <ol style="list-style-type: none"> <li>6. If damaged - REPLACE the door finisher RH and door-mounted curtain air bag module RH with new fasteners.</li> </ol> | G<br>SR<br>I     |
| Pop-up roll bar                        | <p>If the pop-up roll bar NOT deployed:</p> <ol style="list-style-type: none"> <li>1. Check for visible signs of damage (dents tears, deformation, etc.) of the pop-up roll bar.</li> <li>2. If damaged - REPLACE the pop-up roll bar with new fasteners.</li> <li>3. Check harness and connectors for damage, and terminals for deformities.</li> <li>4. If no damage is found, reinstall the pop-up roll bar with new fasteners.</li> <li>5. Check for visible signs of damage (dents, cracks, deformation, etc.) of the seatback support brace assembly.</li> <li>6. If damaged - REPAIR the seatback support brace assembly.</li> </ol>  | J<br>K<br>L      |