

SECTION **SN**
SONAR SYSTEM

A
B
C
D
E
F
G
H
I
J
K
L
M
N
O
P

CONTENTS

BASIC INSPECTION	2	ECU DIAGNOSIS INFORMATION	15
DIAGNOSIS AND REPAIR WORKFLOW	2	SONAR CONTROL UNIT FOR REAR SONAR SYSTEM	15
Work Flow	2	Reference Value	15
INSPECTION AND ADJUSTMENT	4	DTC Index	16
Preliminary Check	4	WIRING DIAGRAM	17
SYSTEM DESCRIPTION	5	SONAR SYSTEM	17
REAR SONAR SYSTEM	5	Wiring Diagram	17
System Diagram	5	SYMPTOM DIAGNOSIS	24
System Description	5	SONAR SYSTEM SYMPTOMS	24
Component Parts Location	6	Symptom Table	24
Component Description	6	PRECAUTION	26
Self-Diagnosis Function	7	PRECAUTION	26
DTC/CIRCUIT DIAGNOSIS	9	Precaution for Supplemental Restraint System (SRS) "AIR BAG" and "SEAT BELT PRE-TENSIONER"	26
POWER SUPPLY AND GROUND CIRCUIT	9	UNIT REMOVAL AND INSTALLATION	27
Diagnosis Procedure	9	SONAR SENSOR	27
SONAR SENSOR CIRCUIT INSPECTION	10	Removal and Installation	27
Description	10	SONAR CONTROL UNIT	28
Diagnosis Procedure	10	Removal and Installation	28
SONAR BUZZER CIRCUIT INSPECTION	11	BUZZER	29
Description	11	Removal and Installation	29
Diagnosis Procedure	11		
Component Inspection	11		
SONAR SYSTEM OFF SWITCH CIRCUIT INSPECTION	13		
Description	13		
Diagnosis Procedure	13		
Component Inspection	13		

SN

DIAGNOSIS AND REPAIR WORKFLOW

< BASIC INSPECTION >

BASIC INSPECTION

DIAGNOSIS AND REPAIR WORKFLOW

Work Flow

INFOID:000000007303720

WORK FLOW

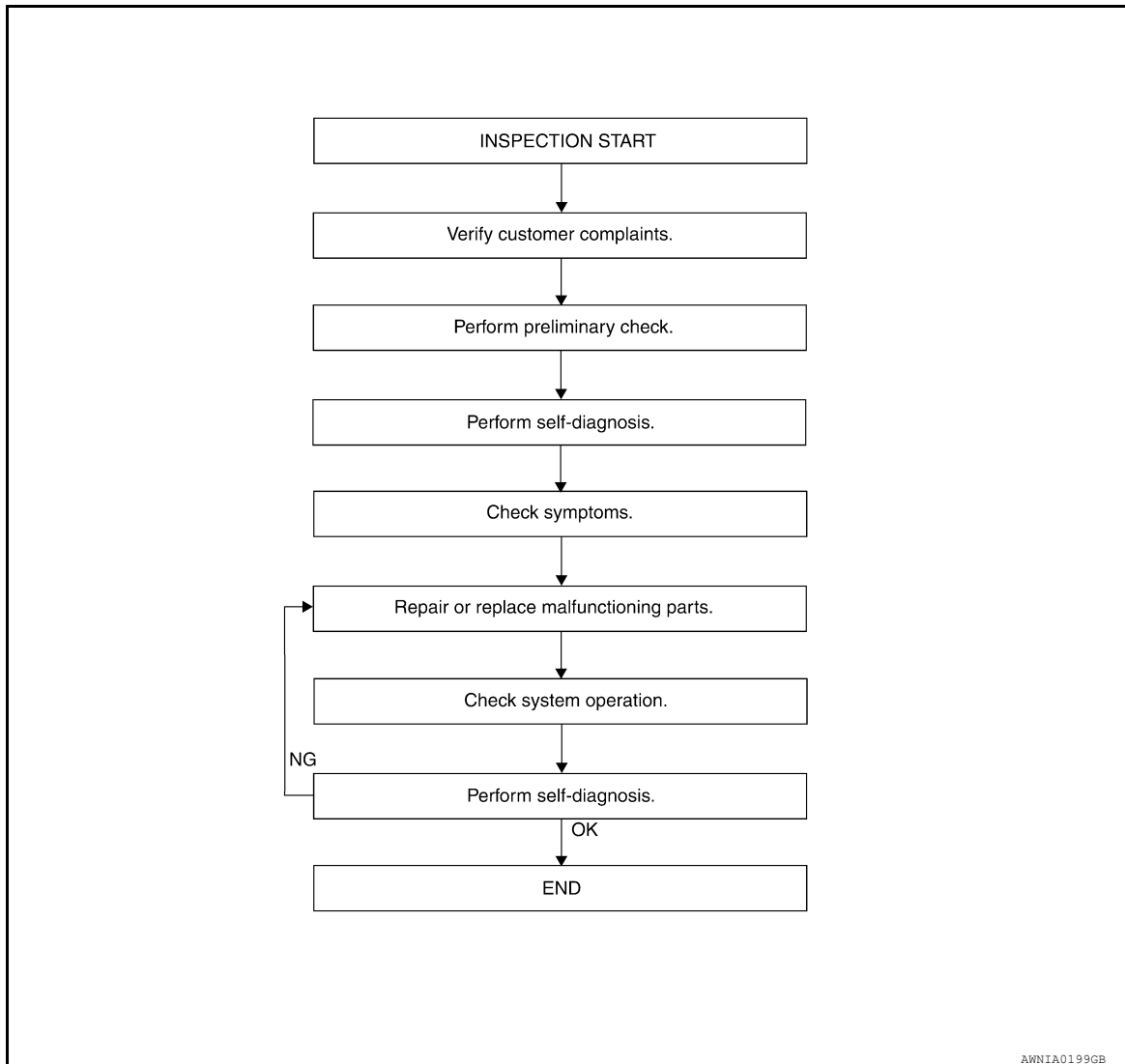

DETAILED FLOW

1. CUSTOMER INFORMATION

Interview the customer to obtain detailed information about the symptom.

>> GO TO 2

2. PRELIMINARY CHECK

Perform preliminary check. Refer to [SN-4. "Preliminary Check"](#).

>> GO TO 3

3. SELF-DIAGNOSIS

Perform self-diagnosis. Refer to [SN-7. "Self-Diagnosis Function"](#).

DIAGNOSIS AND REPAIR WORKFLOW

< BASIC INSPECTION >

>> GO TO 4

4.SYMPTOM

Check for symptoms. Refer to [SN-24. "Symptom Table"](#).

>> GO TO 5

5.MALFUNCTIONING PARTS

Repair or replace the applicable parts.

>> GO TO 6

6.SYSTEM OPERATION

Check system operation.

>> GO TO 7

7.SELF-DIAGNOSIS

Perform self-diagnosis.

Are any fault codes displayed?

YES >> GO TO 5

NO >> Inspection End.

A

B

C

D

E

F

G

H

I

J

K

L

M

SN

O

P

INSPECTION AND ADJUSTMENT

< BASIC INSPECTION >

INSPECTION AND ADJUSTMENT

Preliminary Check

INFOID:000000007303721

DESCRIPTION

The purpose of the sonar sensor preliminary check is to confirm that there are no outside factors affecting the sonar system.

CONDITIONS

- Ignition switch ON
- No obstructions within 3.0 m (10 ft.) of sonar sensors

SONAR SENSOR STATUS CHECK

- Check that the sonar sensors are properly aligned (no deformation in sensor mounting areas).
- Check that snow, mud or other foreign objects are not adhering to the sonar sensors.
- Check that there is no deformation, scratches or other damage to the sonar sensors.
- Check that water has not accumulated in the sonar sensors.

CAUTION:

Use water, cotton swab, or other soft material for cleaning the sensors.

1. Inspect for the following:
 - Physical damage to wiring
 - Physical damage to harness connectors
 - Loose or disconnected harness connectors
 - Physical damage to system components
2. Check that there are no obstacles within each sonar sensor's detection range.

Sonar sensors	Detection range
Rear	Approx. 1.8 m (5.9 ft.) maximum

3. Check that there are no nearby ultrasound sources such as the sounds of vehicle horns, motorcycle engines or truck air brakes.
4. Check that the vehicle is on a level surface.

REAR SONAR SYSTEM

< SYSTEM DESCRIPTION >

SYSTEM DESCRIPTION

REAR SONAR SYSTEM

System Diagram

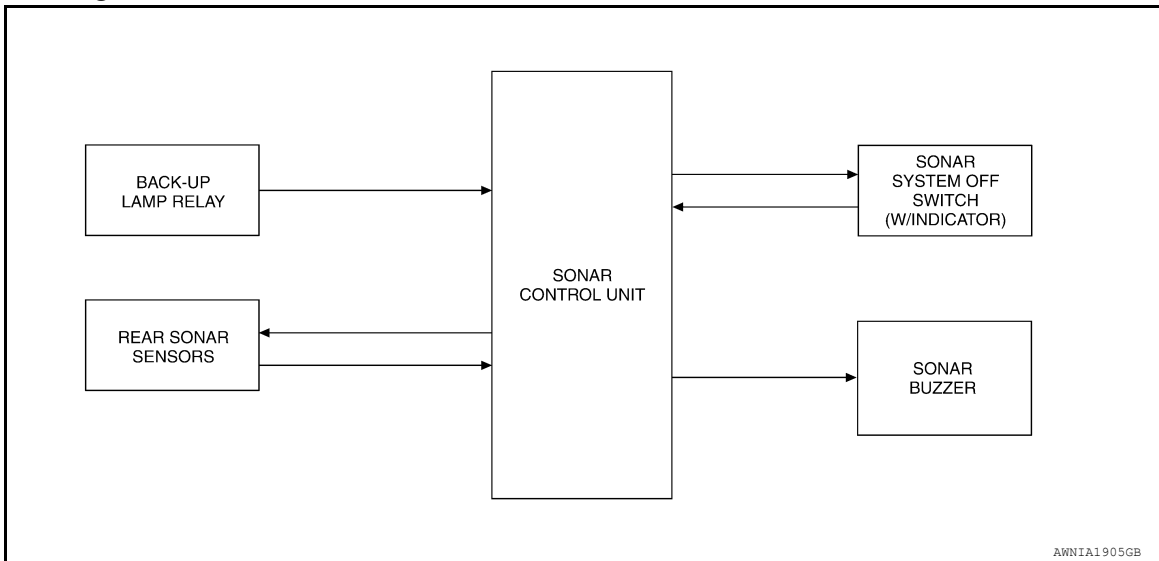

System Description

INFOID:000000007303723

FUNCTION

With power and ground supplied, transmission gear selector lever in R position, and the sonar system OFF switch ON, the rear sonar system will detect obstacles within 1.8 m (5.9 ft.) of the rear sonar sensors. The vehicle operator is notified of obstacles by varied rate of tone from the rear sonar buzzer depending on distance of obstacle being sensed.

SONAR SYSTEM OFF SWITCH

With power and ground supplied to the sonar control unit, transmission gear selector lever in R position, the sonar system can be disabled and the sonar buzzer silenced by momentarily pressing the sonar system OFF switch. The sonar system OFF indicator lamp will be illuminated in the sonar system OFF switch.

The rear sonar system and buzzer will be disabled and the sonar system OFF indicator will be illuminated until the ignition switch is turned OFF. When the ignition switch is turned ON, the rear sonar system will be enabled. Depressing the sonar system OFF switch again will enable the rear sonar system also. Enabling the rear sonar system will cause the rear sonar system OFF indicator to go out. If the sonar control unit detects a malfunction in the system it will turn off the sonar system and the indicator lamp will turn on.

REAR SONAR BUZZER

With power and ground supplied to the sonar control unit and the A/T selector lever in R position, a stationary object that is at least 7.0 cm (2.8 in.) wide and 1.0 m (39.0 in.) tall and that is closer than 1.8 m (5.9 ft.) will be detected by the rear sonar sensors, causing the rear sonar buzzer to sound a tone. As the vehicle moves closer to the object, the rate of the tone will increase. When the object is less than 25.0 cm (10 in.) from the rear bumper, the tone will sound continuously.

REAR SONAR SENSORS

With power and ground supplied to the rear sonar sensors, the sonar sensors transmit an ultrasonic signal. This signal is reflected back to the sensor by objects large enough and close enough to be detected. The rear sonar sensors measure the time from the transmitted signal to the time the signal is reflected back and sends this information to the sonar control unit.

BACK-UP LAMP RELAY

The back-up lamp relay provides a reverse signal to the sonar control unit.

REAR SONAR SYSTEM

< SYSTEM DESCRIPTION >

Component Parts Location

INFOID:000000007303724

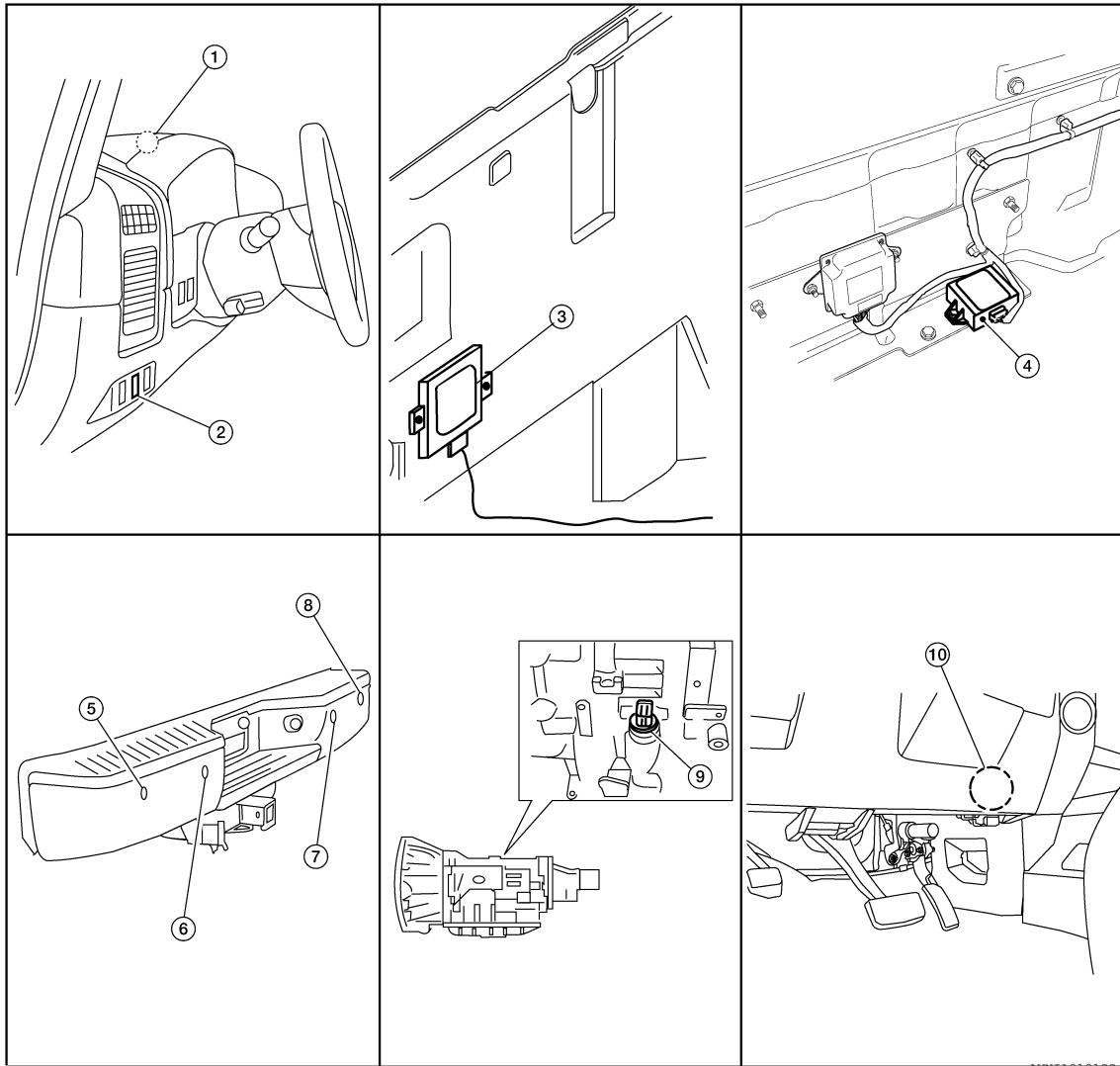

- | | | |
|--|------------------------------------|---|
| 1. Rear sonar buzzer M116 | 2. Sonar system OFF switch M117 | 3. Sonar control unit B24 (crew cab, view of rear cab) |
| 4. Sonar control unit B24 (king cab, view of rear cab) | 5. Rear sonar sensor LH outer C102 | 6. Rear sonar sensor LH inner C103 |
| 7. Rear sonar sensor RH inner C104 | 8. Rear sonar sensor RH outer C105 | 9. A/T assembly (F9 with floor shift) (F17 with column shift) |
| 10. Back-up lamp relay M73 | | |

Component Description

INFOID:000000007303725

Component	Function
Sonar control unit	Controls sonar system and provides self-diagnosis
Back-up lamp relay	Provides reverse signal for sonar control unit
A/T assembly	Controls back-up lamp relay
Rear sonar buzzer	Sounds a signal when objects are detected in the rear of the vehicle
Sonar system OFF switch	Enables the driver to turn system off and signals a system malfunction
Sonar sensor	Senses objects in the rear of the vehicle

REAR SONAR SYSTEM

< SYSTEM DESCRIPTION >

Self-Diagnosis Function

INFOID:000000007303726

NOTE:

Always perform Preliminary Check before running Self-Diagnosis Function. Refer to [SN-4, "Preliminary Check"](#).

There are four modes of self-diagnosis. These modes must be followed in the following order:

1. Entering diagnostics mode
2. Requesting number of fault codes mode
3. Requesting fault codes mode
4. Clearing fault codes mode

Self-diagnosis can be manually exited by turning the ignition OFF or selecting reverse gear. Self-diagnosis will exit unless a fault code request occurs before a message is repeated five times without acknowledgement.

ENTERING DIAGNOSTICS MODE

1. Turn ignition switch ON. Sonar system OFF switch indicator lamp illuminates for three seconds and then turns off.
2. Immediately push sonar system OFF switch ten times within five seconds.
3. The rear sonar buzzer will sound once and the sonar system OFF indicator will flash once.

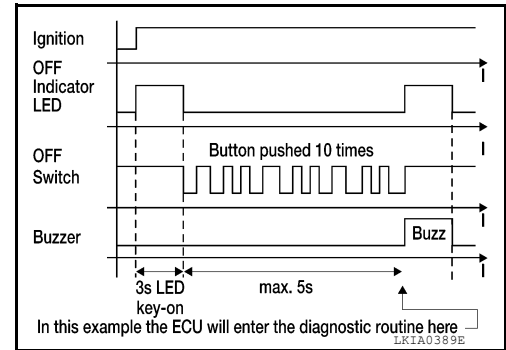

REQUESTING NUMBER OF FAULT CODES MODE

1. While in "entering diagnostic mode", push sonar system OFF switch once within 30 seconds of entering diagnostic mode.

NOTE:

If the number of fault codes is not requested within 30 seconds after entering diagnostic mode, the system will return to regular operation mode.

2. The rear sonar buzzer will sound once.
3. Sonar system OFF indicator will flash once and rear sonar buzzer will sound once for each fault code detected.
4. There will be a four second pause.
5. The number of fault codes will repeat five times then pause.

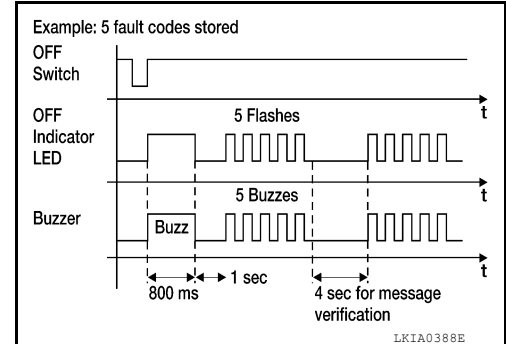

NOTE:

Self-diagnosis will exit unless "requesting fault codes mode" occurs before five repeats ends.

REQUESTING FAULT CODES MODE

1. While in "requesting number of fault codes" mode, push sonar system OFF switch once.
2. The rear sonar buzzer will sound once.
3. Sonar system OFF indicator will flash and rear sonar buzzer will sound the first digit of the fault code followed by a one second pause.
4. Sonar system OFF indicator will flash and rear sonar buzzer will sound the second digit of the fault code followed by a four second pause.
5. Each fault code will repeat five times then pause.
6. Write down each fault code. Then, acknowledge the fault code by pushing the sonar system OFF switch once (the rear sonar buzzer may sound).

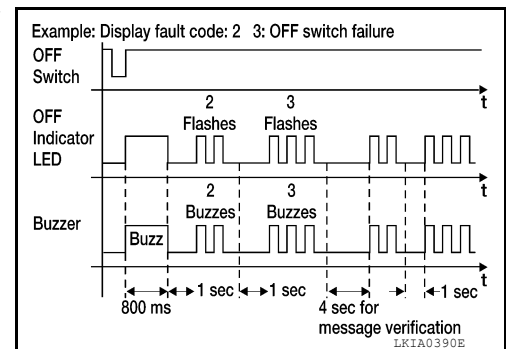

NOTE:

A
B
C
D
E
F
G
H
I
J
K
L
M

SN

O
P

REAR SONAR SYSTEM

< SYSTEM DESCRIPTION >

"Requesting fault codes mode" will exit unless the fault code is acknowledged before it is repeated five times. When all fault codes have been indicated, "clearing fault codes mode" will be entered. Refer to [SN-16. "DTC Index"](#).

CLEARING FAULT CODES MODE

NOTE:

While in "clearing fault codes mode", self-diagnosis will automatically exit if no activity occurs for 30 seconds.

1. Push and hold sonar system OFF switch for three seconds to reset time-out counter.
2. Push and hold sonar system OFF switch for three seconds to clear codes.

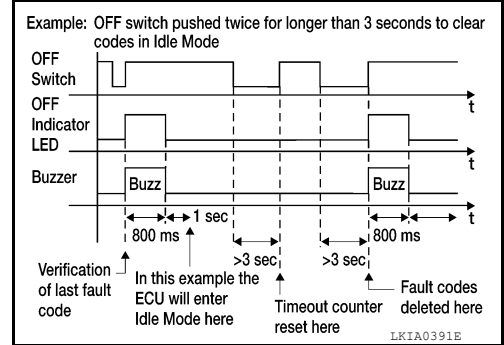

POWER SUPPLY AND GROUND CIRCUIT

< DTC/CIRCUIT DIAGNOSIS >

DTC/CIRCUIT DIAGNOSIS

POWER SUPPLY AND GROUND CIRCUIT

Diagnosis Procedure

INFOID:000000007303727

Regarding Wiring Diagram information, refer to [SN-17. "Wiring Diagram"](#).

INSPECTION FOR POWER SUPPLY AND GROUND CIRCUIT

1. CHECK FUSES

Check for blown rear sonar system fuses.

Unit	Power Source	Fuse	Location
Sonar control unit	ON or START	12	Fuse block (J/B)
		51	IPDM E/R

Are any fuses blown?

YES >> If fuse is blown, be sure to eliminate cause of malfunction before installing new fuse. Refer to [GL-42. "Circuit Inspection"](#).

NO >> GO TO 2.

2. CHECK POWER SUPPLY CIRCUIT

1. Disconnect sonar control unit connector.
2. Turn ignition switch ON.
3. Check voltage between sonar control unit connector B24 terminal 8 and ground.

Terminals		Ignition switch position
(+)	(-)	
Connector	Terminal	ON or START
B24	8	Battery voltage

Is there battery voltage?

YES >> GO TO 3.

NO >> Check harness for open between sonar control unit and fuse.

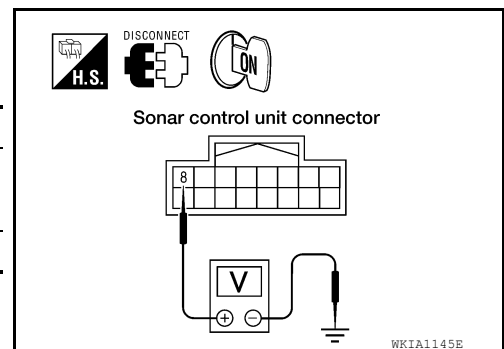

3. CHECK GROUND CIRCUIT

1. Turn ignition switch OFF.
2. Check continuity between sonar control unit connector B24 terminal 6 and ground.

Terminals		Continuity
(+)	(-)	
Connector	Terminal	
B24	6	Ground
		Yes

Is there continuity?

YES >> Inspection End.

NO >> Check harness ground circuit.

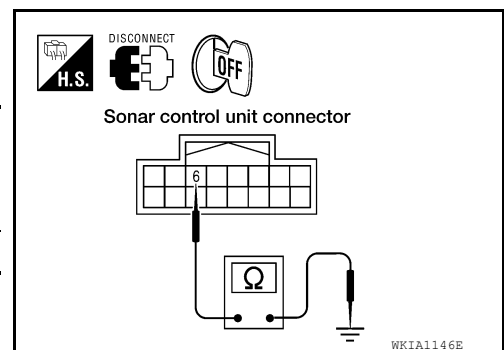

SONAR SENSOR CIRCUIT INSPECTION

< DTC/CIRCUIT DIAGNOSIS >

SONAR SENSOR CIRCUIT INSPECTION

Description

INFOID:000000007303728

With power and ground supplied to the sonar sensors, the sonar sensors transmit an ultrasonic signal. This signal is reflected back to the sensor by objects large enough and close enough to be detected. The sonar sensors measure the time from the transmitted signal to the time the signal is reflected back and send this information to the sonar control unit. Refer to [SN-5. "System Description"](#) for more details.

Diagnosis Procedure

INFOID:000000007303729

Regarding Wiring Diagram information, refer to [SN-17. "Wiring Diagram"](#).

1. CHECK REAR SONAR SENSOR CIRCUITS

1. Turn ignition switch OFF.
2. Disconnect sonar control unit connector and rear sonar sensor connectors.
3. Check continuity between sonar control unit harness connector (A) and rear sonar sensor harness connectors (B).

Connector	Terminal	Connector	Terminal	Continuity
B24 (A)	16	C102, C103, C104, C105 (B)	1	Yes
	15		3	
	9, 10, 11, 12		2	

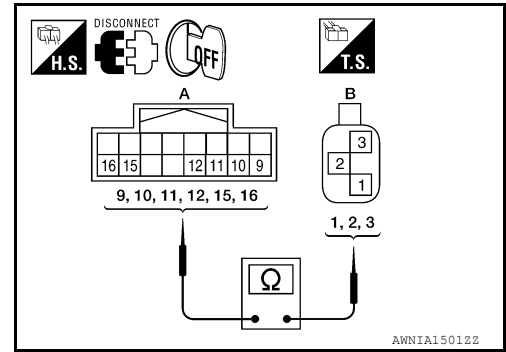

4. Check continuity between sonar control unit harness connector and ground.

Connector	Terminal	Continuity
B24	9, 10, 11, 12, 15, 16	No

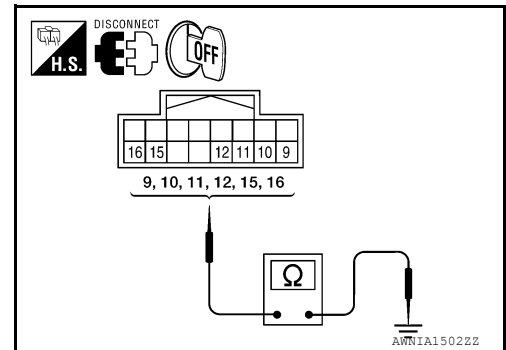

Are the inspection results normal?

- YES >> Inspection End.
 NO >> Repair harness or connector.

SONAR BUZZER CIRCUIT INSPECTION

< DTC/CIRCUIT DIAGNOSIS >

SONAR BUZZER CIRCUIT INSPECTION

Description

INFOID:000000007303730

When the A/T selector lever is not in park or neutral, a stationary object will be detected by the sonar sensors causing the rear sonar buzzer to sound a tone. As the vehicle moves closer to the object, the rate of the tone will increase. When the object is very close to the vehicle, the tone will sound continuously.

Diagnosis Procedure

INFOID:000000007303731

Regarding Wiring Diagram information, refer to [SN-17. "Wiring Diagram"](#).

1. CHECK REAR SONAR BUZZER

Refer to [SN-11. "Component Inspection"](#).

Is the inspection result normal?

YES >> GO TO 2.

NO >> Replace rear sonar buzzer. Refer to [SN-29. "Removal and Installation"](#).

2. CHECK REAR SONAR BUZZER CIRCUIT

1. Turn ignition switch OFF.
2. Disconnect sonar control unit connector and rear sonar buzzer connector.
3. Check continuity between sonar control unit harness connector (A) and rear sonar buzzer harness connector (B).

Connector	Terminal	Connector	Terminal	Continuity
B24 (A)	3	M116 (B)	2	Yes
	7		1	

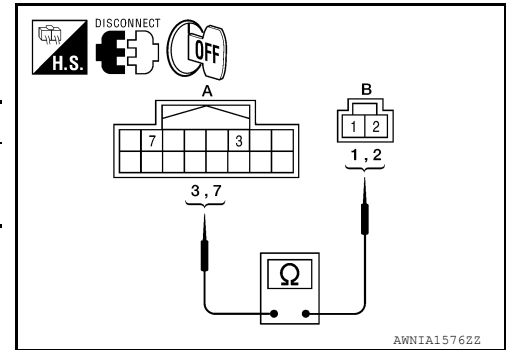

4. Check continuity between sonar control unit harness connector and ground.

Connector	Terminal	Continuity
B24	3, 7	No

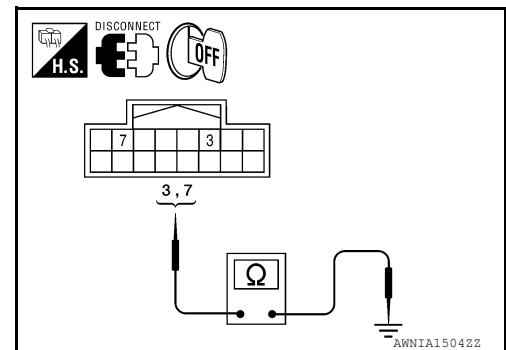

Are the inspection results normal?

YES >> Inspection End.

NO >> Repair harness or connector.

Component Inspection

INFOID:000000007303732

REAR SONAR BUZZER

SONAR BUZZER CIRCUIT INSPECTION

< DTC/CIRCUIT DIAGNOSIS >

1. Disconnect the rear sonar buzzer connector.
2. Check resistance between rear sonar buzzer terminals 1 and 2.

1 - 2

: 50 Ω (+/- 10 Ω)

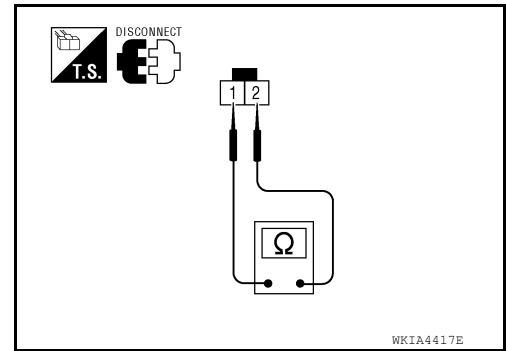

SONAR SYSTEM OFF SWITCH CIRCUIT INSPECTION

< DTC/CIRCUIT DIAGNOSIS >

SONAR SYSTEM OFF SWITCH CIRCUIT INSPECTION

Description

INFOID:000000007303733

The sonar system can be disabled by momentarily pressing the rear sonar system OFF switch. The sonar system OFF indicator lamp will be illuminated when the sonar system is OFF. Enabling the sonar system will cause the sonar system OFF indicator to go out. The indicator will flash if a malfunction exists in the system.

Diagnosis Procedure

INFOID:000000007303734

Regarding Wiring Diagram information, refer to [SN-17. "Wiring Diagram"](#).

1. CHECK SONAR SYSTEM OFF SWITCH

Refer to [SN-13. "Component Inspection"](#).

Is the inspection result normal?

YES >> GO TO 2.

NO >> Replace sonar system OFF switch. Refer to [IP-17. "Removal and Installation"](#).

2. CHECK SONAR SYSTEM OFF SWITCH CIRCUITS

1. Turn ignition switch OFF.
2. Disconnect sonar control unit connector and sonar system OFF switch connector.
3. Check continuity between sonar control unit harness connector (A) and sonar system OFF switch harness connector (B).

Connector	Terminal	Connector	Terminal	Continuity
B24 (A)	4	M117 (B)	5	Yes
	13		1	

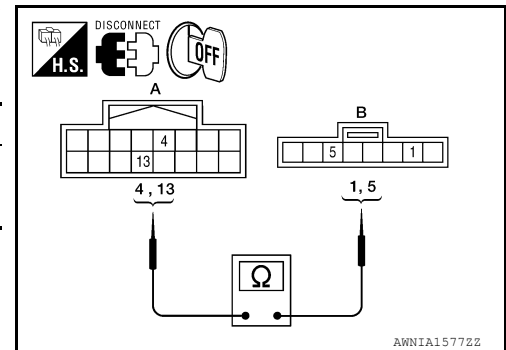

4. Check continuity between sonar system OFF switch harness connector and ground.

Connector	Terminal	Continuity
M117	1, 5	No
	2, 6	Yes

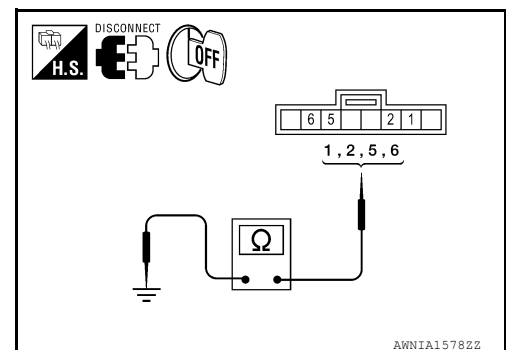

Are the inspection results normal?

YES >> Inspection End.

NO >> Repair harness or connector.

Component Inspection

INFOID:000000007303735

SONAR SYSTEM OFF SWITCH

1. Disconnect the sonar system OFF switch connector.

SONAR SYSTEM OFF SWITCH CIRCUIT INSPECTION

< DTC/CIRCUIT DIAGNOSIS >

2. Check continuity between the following switch terminals.

Sonar system OFF switch	Terminals	Continuity
Depressed	1 - 2	Yes
Released		No

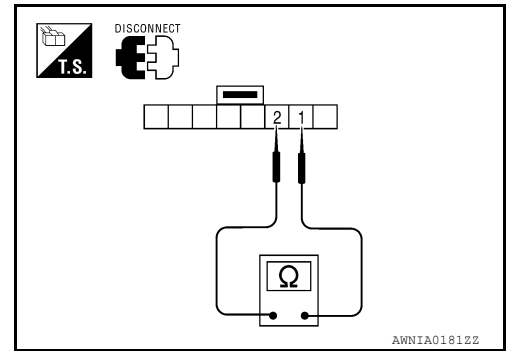

SONAR SYSTEM OFF INDICATOR

1. Disconnect the sonar system OFF switch connector.
2. Apply battery voltage to switch terminal 5.
3. Check the sonar system OFF indicator operation when switch terminal 6 is connected to battery ground.

	Terminals	Condition	Operation
Sonar system OFF switch	5	Battery voltage	Indicator ON
	6	Ground	

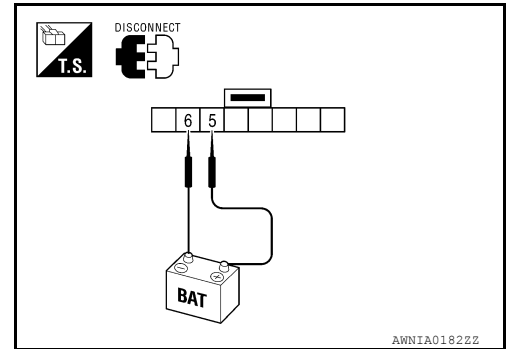

SONAR CONTROL UNIT FOR REAR SONAR SYSTEM

< ECU DIAGNOSIS INFORMATION >

ECU DIAGNOSIS INFORMATION

SONAR CONTROL UNIT FOR REAR SONAR SYSTEM

Reference Value

INFOID:000000007303736

SONAR CONTROL UNIT TERMINAL LAYOUT

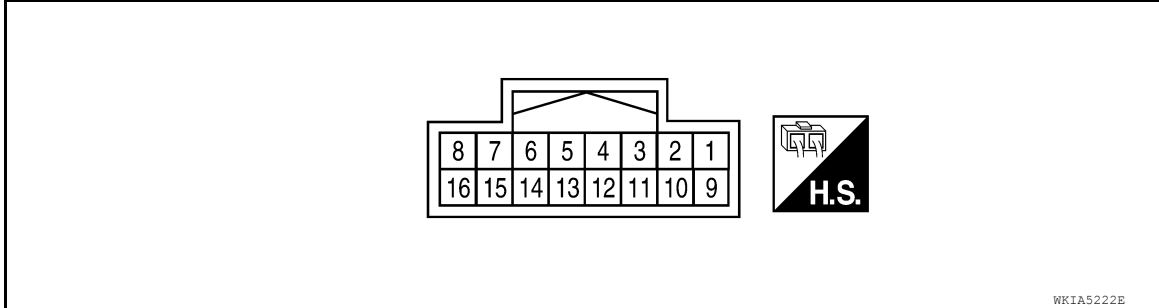

TERMINALS AND REFERENCE VALUES FOR SONAR CONTROL UNIT

Terminal (wire color)	Item	Condition		Reference value (V) (Approx.)	
		Ignition switch	Operation		
3 (R)	Rear sonar buzzer return	ON	—	0 - 12 (variable)	
4 (BR/Y)	Sonar system OFF indicator output	ON	Sonar system OFF switch	ON	0
				OFF	Battery voltage
5 (G/W)	Reverse signal	ON	Transmission gear selector lever	R position	Battery voltage
			Transmission gear selector lever	Not R position	0
6 (B)	Sonar control unit ground	—	—	0	
7 (L)	Rear sonar buzzer drive signal	ON	—	Battery voltage	
8 (G/R)	Sonar control unit power	ON	—	Battery voltage	
9 (GR)	Rear sonar sensor signal - RH outer	ON	<ul style="list-style-type: none"> • Sonar system OFF switch ON • Transmission gear selector lever in R position • No obstacles 	Battery voltage	
10 (P)	Rear sonar sensor signal - LH outer	ON	<ul style="list-style-type: none"> • Sonar system OFF switch ON • Transmission gear selector lever in R position • No obstacles 	Battery voltage	
11 (O)	Rear sonar sensor signal - LH inner	ON	<ul style="list-style-type: none"> • Sonar system OFF switch ON • Transmission gear selector lever in R position • Distance obstacles 	Battery voltage	
12 (LG)	Rear sonar sensor signal - RH inner	ON	<ul style="list-style-type: none"> • Sonar system OFF switch ON • Transmission gear selector lever in R position • Distance obstacles 	Battery voltage	
13 (LG)	Sonar system OFF switch signal	ON	Sonar system OFF switch	ON	0
				OFF	Battery voltage

SONAR CONTROL UNIT FOR REAR SONAR SYSTEM

< ECU DIAGNOSIS INFORMATION >

Terminal (wire color)	Item	Condition		Reference value (V) (Approx.)
		Ignition switch	Operation	
15 (Y)	Rear sonar sensor ground	ON	—	0
16 (LG/B)	Rear sonar sensor power	ON	Ignition switch ON	Battery voltage

DTC Index

INFOID:000000007303737

Fault Code	Malfunction	Service Procedure
11	Rear sonar sensor LH outer	<ol style="list-style-type: none"> 1. Check harness for open or short. 2. Replace sonar sensor. Refer to SN-27, "Removal and Installation".
12	Rear sonar sensor LH inner	
13	Rear sonar sensor RH inner	
14	Rear sonar sensor RH outer	
21	Rear sonar buzzer	<ol style="list-style-type: none"> 1. Refer to SN-11, "Diagnosis Procedure". 2. Check harness for open or short. 3. Refer to SN-24, "Symptom Table".
22	Sonar system OFF indicator	<ol style="list-style-type: none"> 1. Refer to SN-13, "Diagnosis Procedure". 2. Check harness for open or short. 3. Refer to symptom table.
23	Sonar system OFF switch	
24	Sonar control unit	Replace sonar control unit. Refer to SN-28, "Removal and Installation" .

SONAR SYSTEM

< WIRING DIAGRAM >

WIRING DIAGRAM

SONAR SYSTEM

Wiring Diagram

INFOID:000000007303738

FS : FLOOR SHIFT
CS : COLUMN SHIFT

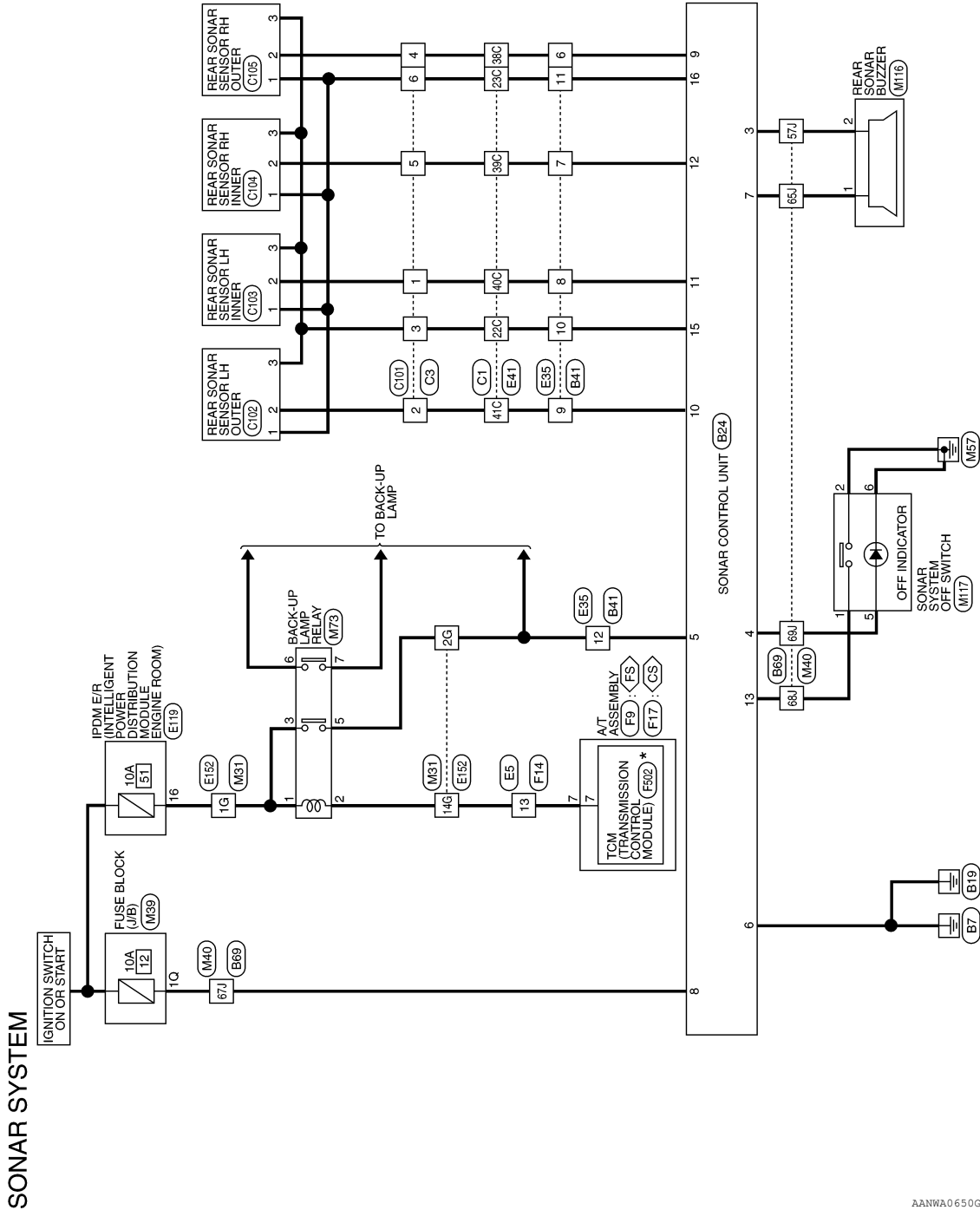

* : THIS CONNECTOR IS NOT SHOWN IN "HARNES LAYOUT" OF PG SECTION.

AANWA0650GB

A
B
C
D
E
F
G
H
I
J
K
L
M
N
O
P

SN

SONAR SYSTEM CONNECTORS

Connector No.	M31
Connector Name	WIRE TO WIRE
Connector Color	WHITE

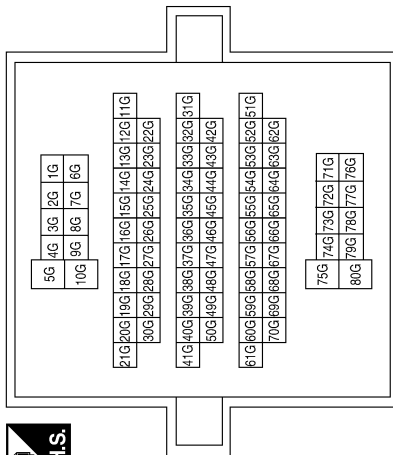

Terminal No.	Color of Wire	Signal Name
1G	G	-
2G	G/W	-
14G	R	-

Connector No.	M39
Connector Name	FUSE BLOCK (J/B)
Connector Color	WHITE

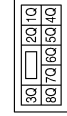

Terminal No.	Color of Wire	Signal Name
1Q	G/R	-

Connector No.	M40
Connector Name	WIRE TO WIRE
Connector Color	WHITE

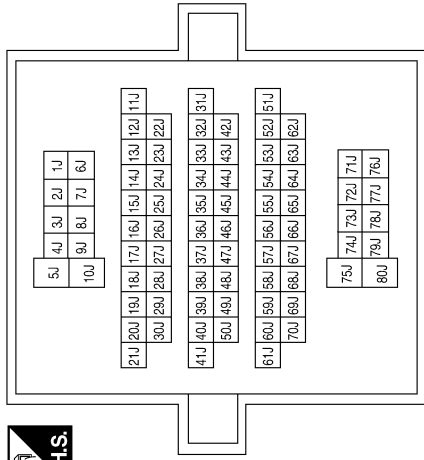

Terminal No.	Color of Wire	Signal Name
57J	R	-
65J	L	-
67J	G/R	-
68J	LG	-
69J	BR/Y	-

Connector No.	M73
Connector Name	BACK-UP LAMP RELAY
Connector Color	BROWN



Terminal No.	Color of Wire	Signal Name
1	G	-
2	R	-
3	G	-
5	G/W	-
6	W/B	-
7	Y/R	-

ABNIA0107GB

SONAR SYSTEM

< WIRING DIAGRAM >

Connector No.	E5
Connector Name	WIRE TO WIRE
Connector Color	WHITE

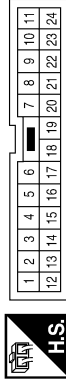

Terminal No.	Color of Wire	Signal Name
13	R	-

Connector No.	M117
Connector Name	SONAR SYSTEM OFF SWITCH
Connector Color	GRAY

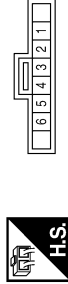

Terminal No.	Color of Wire	Signal Name
1	LG	-
2	B	-
5	BR/Y	-
6	B	-

Connector No.	M116
Connector Name	REAR SONAR BUZZER
Connector Color	BLACK



Terminal No.	Color of Wire	Signal Name
1	L	-
2	R	-

Terminal No.	Color of Wire	Signal Name
22C	Y	-
23C	LG/B	-
38C	GR	-
39C	LG	-
40C	O	-
41C	P	-

Connector No.	E41
Connector Name	WIRE TO WIRE
Connector Color	GRAY

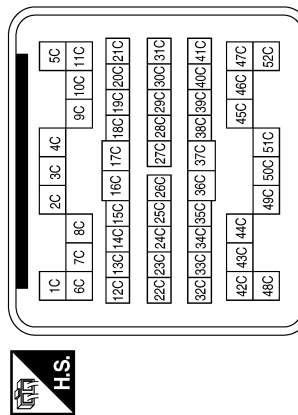

Connector No.	E35
Connector Name	WIRE TO WIRE
Connector Color	WHITE

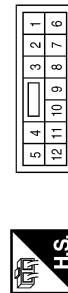

Terminal No.	Color of Wire	Signal Name
6	GR	-
7	LG	-
8	O	-
9	P	-
10	Y	-
11	LG/B	-
12	G/W	-

ABN1A1322GB

A
B
C
D
E
F
G
H
I
J
K
L
M
N
O
P

SN

SONAR SYSTEM

< WIRING DIAGRAM >

Terminal No.	Color of Wire	Signal Name
1G	G	-
2G	G/W	-
14G	R	-

Connector No.	E152
Connector Name	WIRE TO WIRE
Connector Color	WHITE

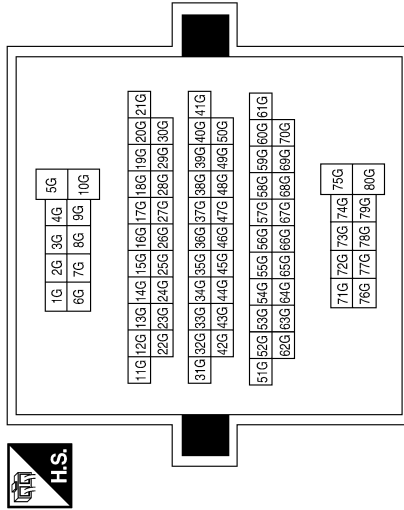

Connector No.	E119
Connector Name	IPDM E/R (INTELLIGENT POWER DISTRIBUTION MODULE ENGINE ROOM)
Connector Color	WHITE

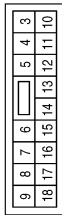

Terminal No.	Color of Wire	Signal Name
16	G	REVERSE LAMP



Connector No.	F17
Connector Name	A/T ASSEMBLY (WITH COLUMN SHIFT)
Connector Color	GREEN

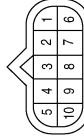

Terminal No.	Color of Wire	Signal Name
7	R	-

Connector No.	F14
Connector Name	WIRE TO WIRE
Connector Color	WHITE

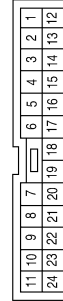

Terminal No.	Color of Wire	Signal Name
13	R	-

Connector No.	F9
Connector Name	A/T ASSEMBLY (WITH FLOOR SHIFT)
Connector Color	GREEN

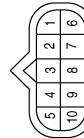

Terminal No.	Color of Wire	Signal Name
7	R	-

ABNIA0109GB

SONAR SYSTEM

< WIRING DIAGRAM >

Terminal No.	Color of Wire	Signal Name
22C	Y	-
23C	LG/B	-
38C	GR	-
39C	LG	-
40C	O	-
41C	P	-

Connector No.	C1
Connector Name	WIRE TO WIRE
Connector Color	GRAY

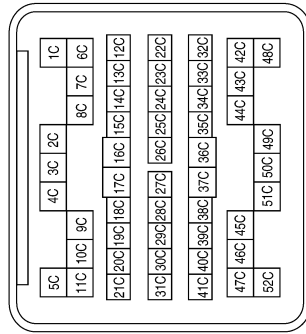

Connector No.	F502
Connector Name	TCM (TRANSMISSION CONTROL MODULE)
Connector Color	GRAY

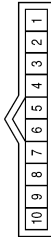

Terminal No.	Color of Wire	Signal Name
7	O	REV LAMP RLY

Connector No.	C102
Connector Name	REAR SONAR SENSOR LH OUTER
Connector Color	BLACK

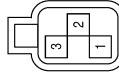

Connector No.	C101
Connector Name	WIRE TO WIRE
Connector Color	GRAY



Connector No.	C3
Connector Name	WIRE TO WIRE
Connector Color	GRAY



Terminal No.	Color of Wire	Signal Name
1	LG/B	PWR
2	P	SIGNAL
3	Y	GND

Terminal No.	Color of Wire	Signal Name
1	O	-
2	P	-
3	Y	-
4	GR	-
5	LG	-
6	LG/B	-

Terminal No.	Color of Wire	Signal Name
1	O	-
2	P	-
3	Y	-
4	GR	-
5	LG	-
6	LG/B	-

ABNIA1143GB

A B C D E F G H I J K L M N O P

SN

SONAR SYSTEM

< WIRING DIAGRAM >

Connector No.	C105
Connector Name	REAR SONAR SENSOR RH OUTER
Connector Color	BLACK

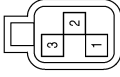

Terminal No.	Color of Wire	Signal Name
1	LG/B	PWR
2	GR	SIGNAL
3	Y	GND

Connector No.	C104
Connector Name	REAR SONAR SENSOR RH INNER
Connector Color	BLACK

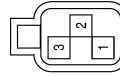

Terminal No.	Color of Wire	Signal Name
1	LG/B	PWR
2	LG	SIGNAL
3	Y	GND

Connector No.	C103
Connector Name	REAR SONAR SENSOR LH INNER
Connector Color	BLACK

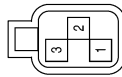

Terminal No.	Color of Wire	Signal Name
1	LG/B	PWR
2	O	SIGNAL
3	Y	GND

Connector No.	B41
Connector Name	WIRE TO WIRE
Connector Color	WHITE

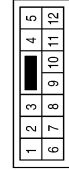

Terminal No.	Color of Wire	Signal Name
6	GR	-
7	LG	-
8	O	-
9	P	-
10	Y	-
11	LG/B	-
12	G/W	-

Terminal No.	Color of Wire	Signal Name
9	GR	SENSOR SIGNAL ROR
10	P	SENSOR SIGNAL ROL
11	O	SENSOR SIGNAL RIL
12	LG	SENSOR SIGNAL RIR
13	LG	ON/OFF SWITCH
14	-	-
15	Y	REAR SENSOR GND
16	LG/B	REAR SENSOR PWR

Connector No.	B24
Connector Name	SONAR CONTROL UNIT
Connector Color	WHITE

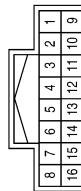

Terminal No.	Color of Wire	Signal Name
1	-	-
2	-	-
3	R	SOUNDER -
4	BR/Y	STATUS LED
5	G/W	REVERSE LAMP SIGNAL
6	B	A1 GND
7	L	SOUNDER +
8	G/R	A1 PWR

ABNIA1144GB

SONAR SYSTEM

< WIRING DIAGRAM >

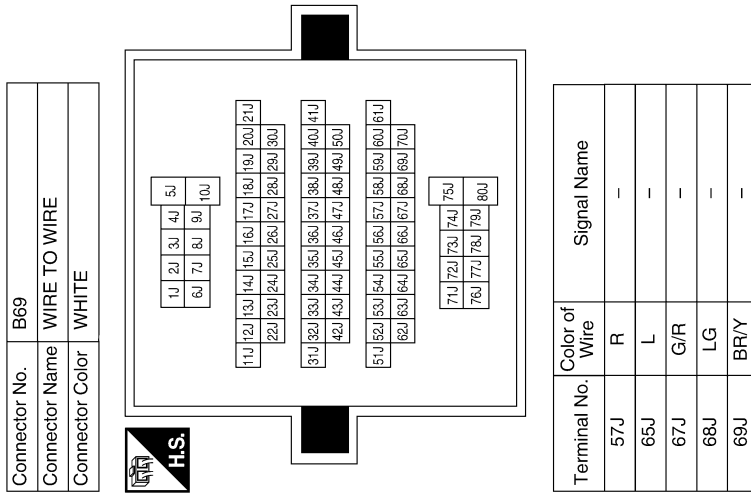

ABNIA1145GB

A
B
C
D
E
F
G
H
I
J
K
L
M
SN
O
P

SONAR SYSTEM SYMPTOMS

< SYMPTOM DIAGNOSIS >

SYMPTOM DIAGNOSIS

SONAR SYSTEM SYMPTOMS

Symptom Table

INFOID:000000007303739

NOTE:

Always perform Preliminary Check and Self-Diagnosis Function before diagnosing vehicle by symptom. Refer to [SN-4, "Preliminary Check"](#) and [SN-7, "Self-Diagnosis Function"](#).

Symptom	Repair order
When the transmission gear selector lever is in the R position and the sonar system is ON, the rear sonar system does not operate.	<ol style="list-style-type: none"> 1. Check sonar control unit power and ground circuits. Refer to SN-9, "Diagnosis Procedure". 2. Check transmission range switch. Refer to TM-51, "Diagnosis Procedure". 3. Check back-up lamp relay. 4. Check related harness and connections for back-up lamp relay. 5. Check rear sonar buzzer. Refer to SN-11, "Diagnosis Procedure". 6. Replace sonar control unit. Refer to SN-28, "Removal and Installation".
Sonar Control Unit will not enter Diagnostic Mode.	<ol style="list-style-type: none"> 1. Check sonar control unit power and ground circuits. Refer to SN-9, "Diagnosis Procedure". 2. Check harness and connections for sonar system OFF switch. Refer to SN-13, "Diagnosis Procedure". 3. Replace sonar control unit. Refer to SN-28, "Removal and Installation".
Buzzer sounds although there are no obstacles within the detection range (false detection).	<ol style="list-style-type: none"> 1. Check all sonar sensors for misalignment or damage (including bumper and fascia). Refer to SN-4, "Preliminary Check". 2. Check all sonar sensors for dirt or ice buildup. Refer to SN-4, "Preliminary Check". 3. Check sonar sensors. Refer to SN-10, "Diagnosis Procedure". 4. Replace sonar control unit. Refer to SN-28, "Removal and Installation".
When sonar system is ON, the sonar system OFF indicator lamp lights up and the sonar buzzer sounds intermittently (for about 4 seconds).	<ol style="list-style-type: none"> 1. Check sonar sensors. Refer to SN-4, "Preliminary Check". 2. Check harnesses between sonar sensors and sonar control unit for an open condition. Refer to SN-10, "Diagnosis Procedure". 3. Replace sonar control unit. Refer to SN-28, "Removal and Installation".
The sonar system still operates when the sonar system OFF indicator lamp is ON.	<ol style="list-style-type: none"> 1. Check sonar system OFF indicator lamp. Refer to SN-13, "Diagnosis Procedure". 2. Replace sonar control unit. Refer to SN-28, "Removal and Installation".
The sonar sensors do not detect objects within the detectable range (intermittent operation).	<ol style="list-style-type: none"> 1. Check sonar sensors. Refer to SN-4, "Preliminary Check". 2. Replace sonar control unit. Refer to SN-28, "Removal and Installation".
When the sonar system is OFF, the OFF indicator does not light and the rear sonar buzzer does not sound.	<ol style="list-style-type: none"> 1. Check sonar system OFF switch. Refer to SN-13, "Component Inspection". 2. Check harness and connections for sonar system OFF switch. Refer to SN-13, "Diagnosis Procedure". 3. Replace sonar control unit. Refer to SN-28, "Removal and Installation".

SONAR SYSTEM SYMPTOMS

< SYMPTOM DIAGNOSIS >

Symptom	Repair order
When the sonar system is OFF, the OFF indicator lamp does not light but the rear sonar buzzer does sound.	<ol style="list-style-type: none"> 1. Check sonar system OFF indicator lamp. Refer to SN-13, "Component Inspection". 2. Check harness and connections for sonar system OFF indicator lamp. Refer to SN-13, "Diagnosis Procedure". 3. Replace sonar control unit. Refer to SN-28, "Removal and Installation".
When the sonar system is OFF, the rear sonar buzzer does not sound but the OFF indicator lamp lights.	<ol style="list-style-type: none"> 1. Check sonar buzzer. Refer to SN-11, "Component Inspection". 2. Check harness and connections between sonar buzzer and sonar control unit. Refer to SN-11, "Diagnosis Procedure". 3. Replace sonar control unit. Refer to SN-28, "Removal and Installation".

A
B
C
D
E
F
G
H
I
J
K
L
M
N
O
P

SN

PRECAUTION

< PRECAUTION >

PRECAUTION

PRECAUTION

Precaution for Supplemental Restraint System (SRS) "AIR BAG" and "SEAT BELT PRE-TENSIONER"

INFOID:000000007303740

The Supplemental Restraint System such as "AIR BAG" and "SEAT BELT PRE-TENSIONER", used along with a front seat belt, helps to reduce the risk or severity of injury to the driver and front passenger for certain types of collision. This system includes seat belt switch inputs and dual stage front air bag modules. The SRS system uses the seat belt switches to determine the front air bag deployment, and may only deploy one front air bag, depending on the severity of a collision and whether the front occupants are belted or unbelted. Information necessary to service the system safely is included in the SR and SB section of this Service Manual.

WARNING:

- To avoid rendering the SRS inoperative, which could increase the risk of personal injury or death in the event of a collision which would result in air bag inflation, all maintenance must be performed by an authorized NISSAN/INFINITI dealer.
- Improper maintenance, including incorrect removal and installation of the SRS, can lead to personal injury caused by unintentional activation of the system. For removal of Spiral Cable and Air Bag Module, see the SR section.
- Do not use electrical test equipment on any circuit related to the SRS unless instructed to in this Service Manual. SRS wiring harnesses can be identified by yellow and/or orange harnesses or harness connectors.

PRECAUTIONS WHEN USING POWER TOOLS (AIR OR ELECTRIC) AND HAMMERS

WARNING:

- When working near the Airbag Diagnosis Sensor Unit or other Airbag System sensors with the Ignition ON or engine running, DO NOT use air or electric power tools or strike near the sensor(s) with a hammer. Heavy vibration could activate the sensor(s) and deploy the air bag(s), possibly causing serious injury.
- When using air or electric power tools or hammers, always switch the Ignition OFF, disconnect the battery, and wait at least 3 minutes before performing any service.

SONAR SENSOR

< UNIT REMOVAL AND INSTALLATION >

UNIT REMOVAL AND INSTALLATION

SONAR SENSOR

Removal and Installation

INFOID:000000007303741

REMOVAL

1. Disconnect the sonar sensor harness connector.
2. Disconnect the sonar sensor retainers from the rear bumper.
3. Remove the rear sonar sensor (1) from the rear bumper (2).
4. Remove the rear sonar sensor housing and harness from the rear bumper (2).

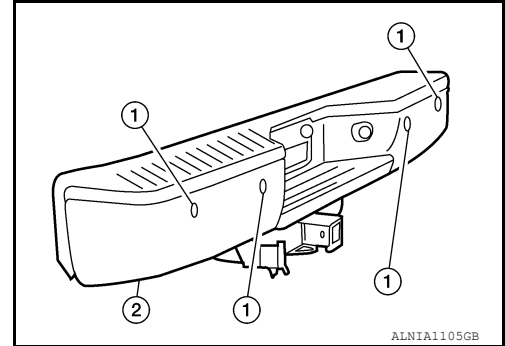

INSTALLATION

Installation is in the reverse order of removal.

A
B
C
D
E
F
G
H
I
J
K
L
M
SN
O
P

SONAR CONTROL UNIT

< UNIT REMOVAL AND INSTALLATION >

SONAR CONTROL UNIT

Removal and Installation

INFOID:000000007303742

REMOVAL

1. Remove the rear panel. Refer to [INT-14, "Removal and Installation"](#).
2. For King Cab models only, pull up the carpet to gain access to the sonar control unit.
3. Disconnect the sonar control unit connector.
 - Sonar control unit (King Cab) (1)
 - Sonar control unit (Crew Cab) (2)
4. Remove the two bolts and remove the sonar control unit.

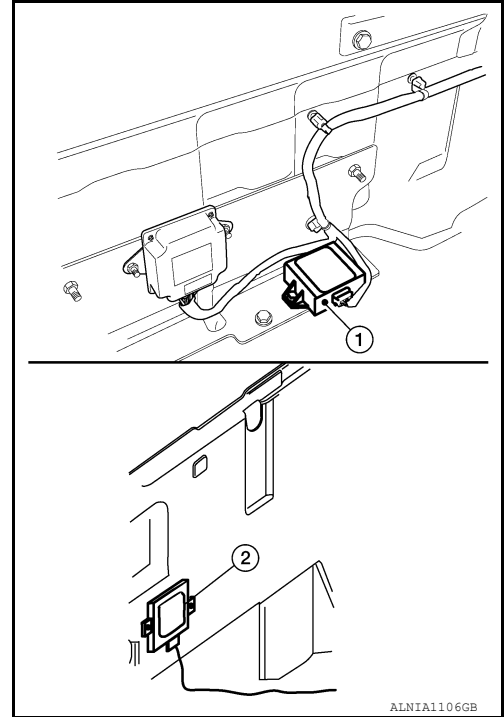

ALNIA1106GB

INSTALLATION

Installation is in the reverse order of removal.

BUZZER

< UNIT REMOVAL AND INSTALLATION >

BUZZER

Removal and Installation

INFOID:000000007303743

REMOVAL

1. Remove the combination meter cover. Refer to [MWI-93. "Removal and Installation"](#).
2. Remove the two bolts (1), disconnect the connector (2) and remove the front buzzer.

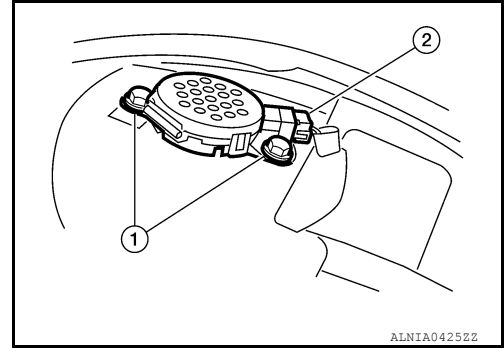

INSTALLATION

Installation is in the reverse order of removal.

A
B
C
D
E
F
G
H
I
J
K
L
M
SN
O
P