

SECTION **BR**
BRAKE SYSTEM

A
B
C
D
E

CONTENTS

PRECAUTION	3	BRAKE MASTER CYLINDER	10	BR
PRECAUTIONS	3	On Board Inspection	10	
Precaution for Supplemental Restraint System (SRS) "AIR BAG" and "SEAT BELT PRE-TENSIONER"	3	BRAKE TUBE AND HOSE	11	G
Precaution for Brake System	3	Hydraulic Circuit	11	
PREPARATION	4	FRONT BRAKE	11	H
PREPARATION	4	FRONT BRAKE : Inspection	11	
Special Service Tool	4	REAR BRAKE	12	I
Commercial Service Tool	4	REAR BRAKE : Inspection	12	
SYSTEM DESCRIPTION	5	PERIODIC MAINTENANCE	13	J
NOISE, VIBRATION AND HARSHNESS (NVH) TROUBLESHOOTING	5	BRAKE PEDAL	13	
NVH Troubleshooting Chart	5	Inspection and Adjustment - Standard Pedal	13	K
BASIC INSPECTION	6	Inspection and Adjustment - Adjustable Pedal	14	
FRONT DISC BRAKE	6	BRAKE FLUID	16	L
BRAKE PAD	6	On Board Inspection	16	
BRAKE PAD : Inspection	6	Drain and Refill	16	
DISC ROTOR	6	Bleeding Brake System	16	
DISC ROTOR : Inspection	6	REMOVAL AND INSTALLATION	18	M
REAR DISC BRAKE	7	BRAKE PEDAL	18	
BRAKE PAD	7	Exploded View	18	N
BRAKE PAD : Inspection	7	Removal and Installation	19	
DISC ROTOR	7	BRAKE TUBE AND HOSE	21	O
DISC ROTOR : Inspection	7	Hydraulic Circuit	21	
BRAKE BOOSTER	8	Removal and Installation of Front Brake Piping and Brake Hose	21	
Inspection	8	Removal and Installation of Rear Brake Piping and Brake Hose	22	P
VACUUM LINES	9	Inspection After Installation	23	
Inspection	9	BRAKE MASTER CYLINDER	25	
		Exploded View	25	
		Removal and Installation	25	
		BRAKE BOOSTER	27	
		Removal and Installation	27	

VACUUM LINES	29	BRAKE MASTER CYLINDER	39
Removal and Installation	29	Disassembly and Assembly	39
FRONT DISC BRAKE	30	FRONT DISC BRAKE	41
Exploded View of Brake Pads	30	Disassembly and Assembly	41
Removal and Installation of Brake Pads	30	REAR DISC BRAKE	44
Brake Burnishing Procedure	31	Disassembly and Assembly	44
Exploded View of Brake Caliper	32	SERVICE DATA AND SPECIFICATIONS	
Removal and Installation of Brake Caliper and Rotor	32	(SDS)	47
REAR DISC BRAKE	35	SERVICE DATA AND SPECIFICATIONS	
Exploded View of Brake Pads	35	(SDS)	47
Removal and Installation of Brake Pad	35	General Specification	47
Brake Burnishing Procedure	36	Brake Pedal	47
Exploded View of Brake Caliper	36	Brake Booster	48
Removal and Installation of Brake Caliper and Disc Rotor	36	Check Valve	49
UNIT DISASSEMBLY AND ASSEMBLY ...	39	Front Disc Brake	49
		Rear Disc Brake	49

PRECAUTIONS

< PRECAUTION >

PRECAUTION

PRECAUTIONS

Precaution for Supplemental Restraint System (SRS) "AIR BAG" and "SEAT BELT PRE-TENSIONER"

INFOID:000000009883521

The Supplemental Restraint System such as "AIR BAG" and "SEAT BELT PRE-TENSIONER", used along with a front seat belt, helps to reduce the risk or severity of injury to the driver and front passenger for certain types of collision. This system includes seat belt switch inputs and dual stage front air bag modules. The SRS system uses the seat belt switches to determine the front air bag deployment, and may only deploy one front air bag, depending on the severity of a collision and whether the front occupants are belted or unbelted. Information necessary to service the system safely is included in the SR and SB section of this Service Manual.

WARNING:

- To avoid rendering the SRS inoperative, which could increase the risk of personal injury or death in the event of a collision which would result in air bag inflation, all maintenance must be performed by an authorized NISSAN/INFINITI dealer.
- Improper maintenance, including incorrect removal and installation of the SRS, can lead to personal injury caused by unintentional activation of the system. For removal of Spiral Cable and Air Bag Module, see the SR section.
- Do not use electrical test equipment on any circuit related to the SRS unless instructed to in this Service Manual. SRS wiring harnesses can be identified by yellow and/or orange harnesses or harness connectors.

PRECAUTIONS WHEN USING POWER TOOLS (AIR OR ELECTRIC) AND HAMMERS

WARNING:

- When working near the Airbag Diagnosis Sensor Unit or other Airbag System sensors with the Ignition ON or engine running, DO NOT use air or electric power tools or strike near the sensor(s) with a hammer. Heavy vibration could activate the sensor(s) and deploy the air bag(s), possibly causing serious injury.
- When using air or electric power tools or hammers, always switch the Ignition OFF, disconnect the battery, and wait at least 3 minutes before performing any service.

Precaution for Brake System

INFOID:000000009883522

- Always use recommended brake fluid. Refer to [MA-15, "FOR NORTH AMERICA : Fluids and Lubricants"](#) (United States and Canada), [MA-16, "FOR MEXICO : Fluids and Lubricants"](#) (Mexico).
- Do not reuse drained brake fluid.
- Be careful not to splash brake fluid on painted areas.
- To clean or wash all parts of master cylinder, disc brake caliper and wheel cylinder, use clean brake fluid.
- Do not use mineral oils such as gasoline or kerosene. They will ruin rubber parts of the hydraulic system.
- Use flare nut wrench when removing and installing brake tube.
- Always check tightening torque when installing brake lines.
- Before working, turn ignition switch to OFF and disconnect connectors for ABS actuator and electric unit (control unit) or battery terminals.
- Burnish the brake contact surfaces after refinishing or replacing drums or rotors, after replacing pads or linings, or if a soft pedal occurs at very low mileage. Refer to [BR-30, "Removal and Installation of Brake Pads"](#).

WARNING:

- Clean dust on caliper and brake pads with a vacuum dust collector to minimize the hazard of air borne particles or other materials.

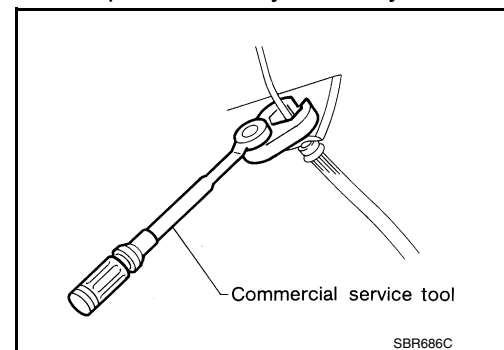

PREPARATION

< PREPARATION >

PREPARATION

PREPARATION

Special Service Tool

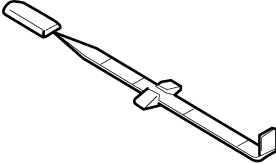
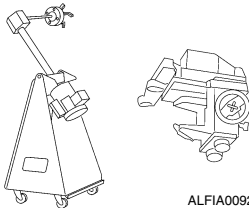

INFOID:000000009883523

The actual shapes of Kent-Moore tools may differ from those of special service tools illustrated here.

Tool number (Kent-Moore No.) Tool name		Description
— (J-46532) Brake and clutch pedal height measurement tool		Measuring brake pedal height
38-PFM90.5 (—) Pro-Cut PFM90 On-Car Brake Lathe		Turning rotors

Commercial Service Tool

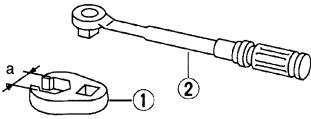
INFOID:000000009883524

Tool name		Description
1. Flare nut crowfoot 2. Torque wrench		Removing and installing each brake piping. a: 10 mm (0.39 in) / 12 mm (0.47 in)
Power tool		Loosening nuts, screws and bolts

NOISE, VIBRATION AND HARSHNESS (NVH) TROUBLESHOOTING

< SYSTEM DESCRIPTION >

SYSTEM DESCRIPTION

NOISE, VIBRATION AND HARSHNESS (NVH) TROUBLESHOOTING

NVH Troubleshooting Chart

INFOID:000000009883525

Use the chart below to help you find the cause of the symptom. If necessary, repair or replace these parts.

Symptom	Possible cause and SUSPECTED PARTS											Reference page				
	Pads - damaged	Pads - uneven wear	Shims damaged	Rotor imbalance	Rotor damage	Rotor runout	Rotor deformation	Rotor deflection	Rotor rust	Rotor thickness variation	PROPELLER SHAFT	DIFFERENTIAL	DRIVESHAFT	SUSPENSION	TIRES AND ROAD WHEEL	STEERING
Noise	x	x	x								x	x	x	x	x	x
Shake				x							x		x	x	x	x
Shimmy, Shudder				x	x	x	x	x	x	x			x	x	x	x

x: Applicable

A
B
C
D
E
F
G
H
I
J
K
L
M
N
O
P

BR

FRONT DISC BRAKE

< BASIC INSPECTION >

BASIC INSPECTION

FRONT DISC BRAKE

BRAKE PAD

BRAKE PAD : Inspection

INFOID:000000009883526

PAD WEAR

Check pad thickness from the inspection holes on cylinder body.
Check using a scale if necessary.

Standard thickness : Refer to [BR-49, "Front Disc Brake"](#).

Repair limit thickness : Refer to [BR-49, "Front Disc Brake"](#).

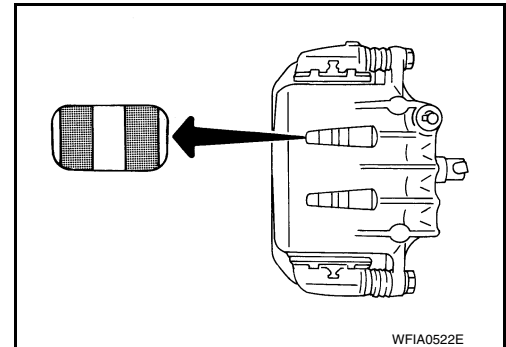

DISC ROTOR

DISC ROTOR : Inspection

INFOID:000000009883527

VISUAL

Check surface of disc rotor for uneven wear, cracks, and serious damage. Replace as necessary.

RUNOUT

1. Attach disc rotor to wheel hub using wheel nuts (at two or more positions).
2. Inspect runout using a dial gauge placed at 10 mm (0.39 in) inside the disc edge.

Runout limit : Refer to [BR-49, "Front Disc Brake"](#).
(with it attached to the vehicle)

NOTE:

Before measuring, make sure that wheel bearing axial end play is within the specification. Refer to [FAX-5, "On-Vehicle Inspection and Service"](#).

3. When runout exceeds limit value, displace mounting positions of disc rotor by one hole. And then find a position of the minimum value for runout.
4. If runout is outside the specified value after performing the above operation, turn disc rotor using Tool.

Tool number : 38-PFM90.5 (—)

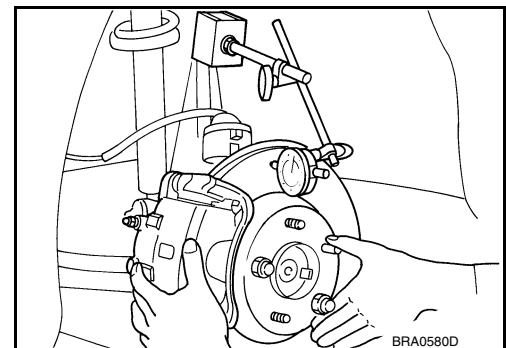

THICKNESS

Check thickness of the disc rotor using a micrometer. Replace disc rotor if thickness is less than the wear limit.

Standard thickness : Refer to [BR-49, "Front Disc Brake"](#).

Repair limit thickness : Refer to [BR-49, "Front Disc Brake"](#).

Maximum uneven wear (Measured at 8 positions) : Refer to [BR-49, "Front Disc Brake"](#).

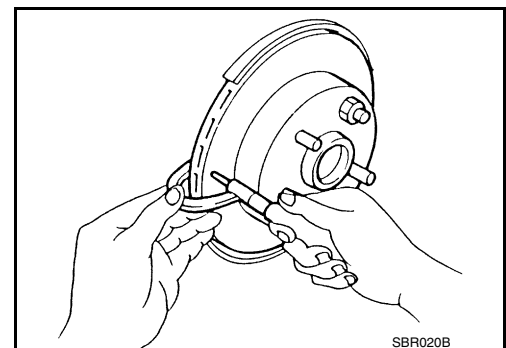

REAR DISC BRAKE

< BASIC INSPECTION >

REAR DISC BRAKE

BRAKE PAD

BRAKE PAD : Inspection

INFOID:000000009883528

PAD WEAR

Check pad thickness from the inspection hole on cylinder body.
Check using a scale if necessary.

Standard thickness : Refer to [BR-49, "Rear Disc Brake"](#).

Repair limit thickness : Refer to [BR-49, "Rear Disc Brake"](#).

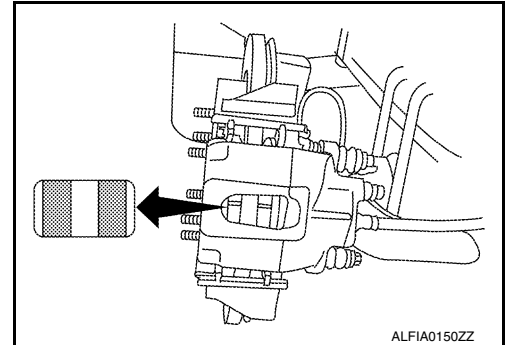

DISC ROTOR

DISC ROTOR : Inspection

INFOID:000000009883529

VISUAL

Check surface of disc rotor for uneven wear, cracks, and serious damage. Replace as necessary.

RUNOUT

1. Attach disc rotor to wheel hub using wheel nuts (at two or more positions).
2. Inspect runout using dial gauge placed at 10 mm (0.39 in) inside disc edge.

Runout limit : Refer to [BR-49, "Rear Disc Brake"](#).
(with it attached to the vehicle)

NOTE:

Before measuring, make sure that wheel bearing axial end play is within the specification. Refer to [FAX-5, "On-Vehicle Inspection and Service"](#).

3. When runout exceeds limit value, displace mounting positions of disc rotor by one hole. And then find a position of the minimum value for runout.
4. If runout is outside the specified value after performing the above operation, turn disc rotor using Tool.

Tool number : 38-PFM90.5 (—)

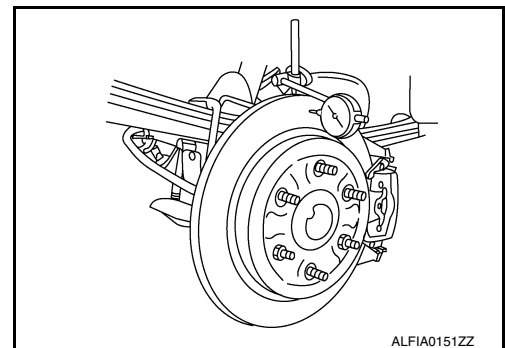

THICKNESS

Check the thickness of the disc rotor using a micrometer. Replace disc rotor if the thickness is under the wear limit.

Standard thickness : Refer to [BR-49, "Rear Disc Brake"](#).

Repair limit thickness : Refer to [BR-49, "Rear Disc Brake"](#).

Maximum uneven wear (Measured at 8 positions) : Refer to [BR-49, "Rear Disc Brake"](#).

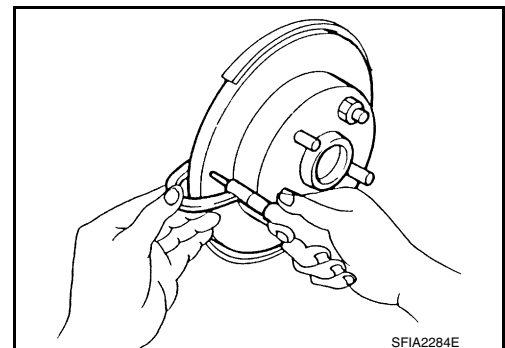

BRAKE BOOSTER

< BASIC INSPECTION >

BRAKE BOOSTER

Inspection

INFOID:000000009883530

OPERATION

With engine stopped, change vacuum to atmospheric pressure by depressing brake pedal several times. Then with brake pedal fully depressed, start engine and when vacuum pressure reaches the standard, make sure that clearance between brake pedal and floor panel decreases.

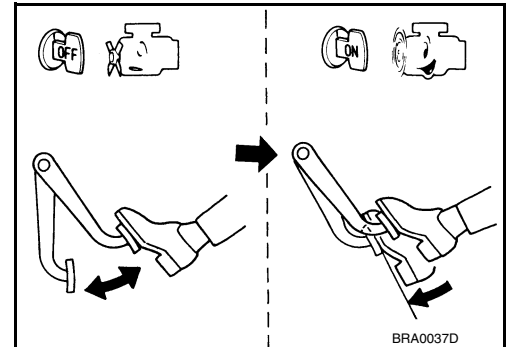

AIR TIGHT

- Run engine at idle for approximately 1 minute, and stop it after applying vacuum to booster. Depress brake pedal normally to change vacuum to atmospheric pressure. Make sure that distance at intervals of 5 seconds between brake pedal and floor panel gradually increases.

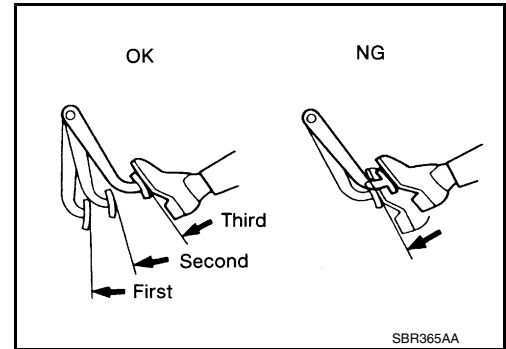

- Depress brake pedal while engine is running, and stop engine with pedal depressed. The pedal stroke should not change after holding pedal down for 30 seconds.

VACUUM LINES

< BASIC INSPECTION >

VACUUM LINES

Inspection

INFOID:000000009883531

VISUAL INSPECTION

Check for improper assembly, damage and deterioration. Replace as necessary.

CHECK VALVE INSPECTION

Airtightness Inspection

Use a suitable vacuum pump to check. Connect to brake booster side of check valve.

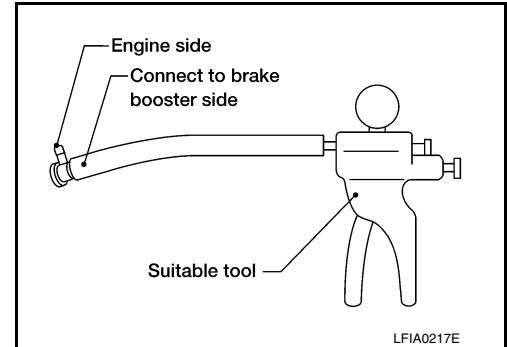

Check valve specification : Refer to [BR-48, "Brake Booster"](#)

BRAKE MASTER CYLINDER

< BASIC INSPECTION >

BRAKE MASTER CYLINDER

On Board Inspection

INFOID:000000009883532

LEAK INSPECTION

Check for leaks at master cylinder to brake booster attachment point, reservoir tank, and brake tube connections.

BRAKE TUBE AND HOSE

< BASIC INSPECTION >

BRAKE TUBE AND HOSE

Hydraulic Circuit

INFOID:000000009883533

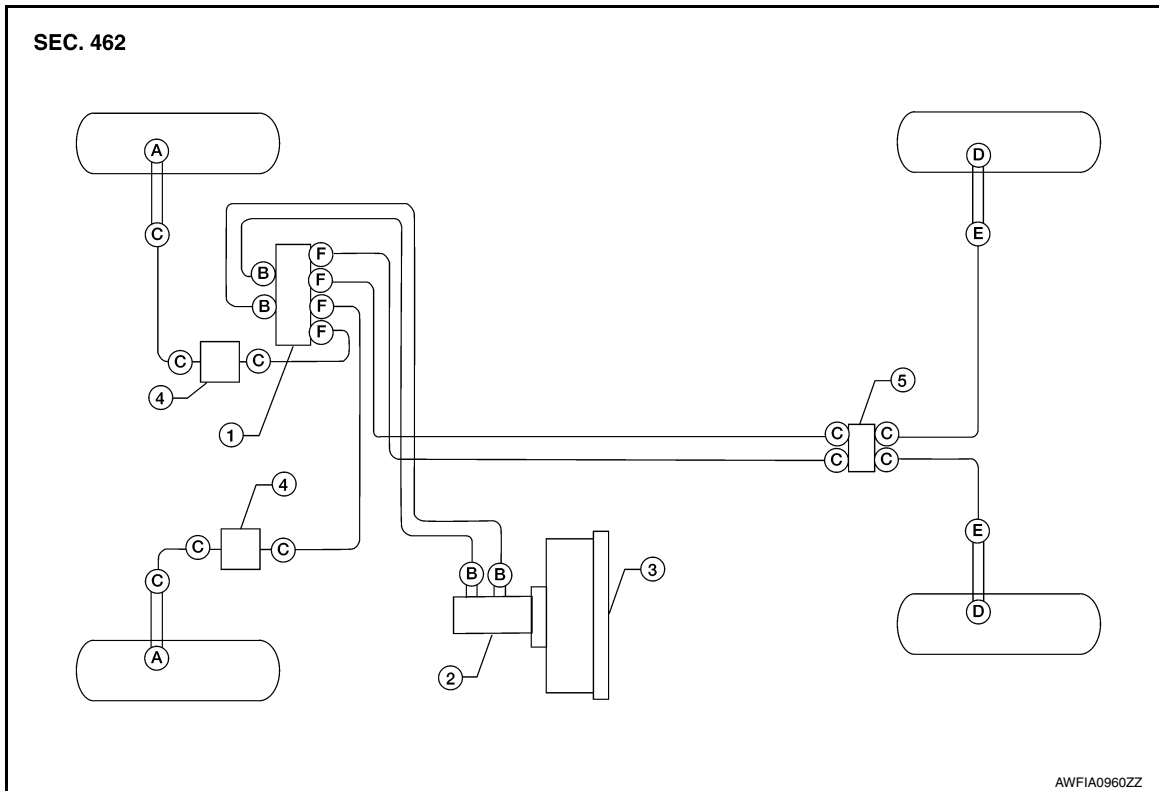

- | | | |
|--|--|--|
| 1. Actuator | 2. Master cylinder | 3. Brake booster |
| 4. Connector | 5. Axle mounted connector
9.3 N·m (0.95 kg-m, 82 in-lb) | A. Union bolt (front caliper)
18.2 N·m (1.9 kg-m, 13 ft-lb) |
| B. Flare nut M12
18.2 N·m (1.9 kg-m, 13 ft-lb) | C. Flare nut M10
16.2 N·m (1.7 kg-m, 12 ft-lb) | D. Hose connection (rear caliper)
18.2 N·m (1.9 kg-m, 13 ft-lb) |
| E. Flare nut to rear hose
16.2 N·m (1.7 kg-m, 12 ft-lb) | F. Flare nut M10
13.0 N·m (1.3 kg-m, 10 ft-lb) | — Brake line |
| = Brake hose | | |

CAUTION:

- All hoses and piping (tubes) must be free from excessive bending, twisting and pulling.
- Make sure there is no interference with other parts when turning the steering wheel both clockwise and counterclockwise.
- The brake piping is an important safety part. If a brake fluid leak is detected, always disassemble the parts. Replace applicable part with a new one, if necessary.
- Be careful not to splash brake fluid on painted areas; it may cause paint damage. If brake fluid is splashed on painted areas, wash it away with water immediately.
- Do not bend or twist brake hose sharply, or strongly pull it.
- Refill with new specified brake fluid. Refer to [MA-15, "FOR NORTH AMERICA : Fluids and Lubricants"](#) (United States and Canada), [MA-16, "FOR MEXICO : Fluids and Lubricants"](#) (Mexico).
- Do not reuse drained brake fluid.

FRONT BRAKE

FRONT BRAKE : Inspection

INFOID:000000009883534

INSPECTION AFTER REMOVAL

CAUTION:

BRAKE TUBE AND HOSE

< BASIC INSPECTION >

Brake tubes and hoses are important safety parts. Always disassemble the parts and retighten their fittings, if a brake fluid leak is detected. Replace applicable part with a new one, if damaged part is detected.

1. Check brake lines (tubes and hoses) and connections for fluid leaks, damage, twists, deformation, contact with other parts, and loose connections. Replace any parts as necessary. Refer to [BR-21, "Hydraulic Circuit"](#).
2. While depressing brake pedal under a force of 785 N (80 kg-f, 177 lb-f) with engine running for approximately 5 seconds, check each part for fluid leaks.

REAR BRAKE

REAR BRAKE : Inspection

INFOID:000000009883535

INSPECTION AFTER REMOVAL

CAUTION:

Brake tubes and hoses are important safety parts. Always disassemble the parts and retighten their fittings, if a brake fluid leak is detected. Replace applicable part with a new one, if damaged part is detected.

1. Check brake lines (tubes and hoses) and connections for fluid leaks, damage, twists, deformation, contact with other parts, and loose connections. Replace any parts as necessary. Refer to [BR-21, "Hydraulic Circuit"](#).
2. While depressing brake pedal under a force of 785 N (80 kg-f, 177 lb-f) with engine running for approximately 5 seconds, check each part for fluid leaks.

BRAKE PEDAL

< PERIODIC MAINTENANCE >

PERIODIC MAINTENANCE

BRAKE PEDAL

Inspection and Adjustment - Standard Pedal

INFOID:000000009883536

INSPECTION

1. Inspect the brake pedal free height (H) from the floor using Tool at a 90° angle to the floor as shown.

Tool number : — (J-46532)

2. Adjust the brake pedal height to specifications.

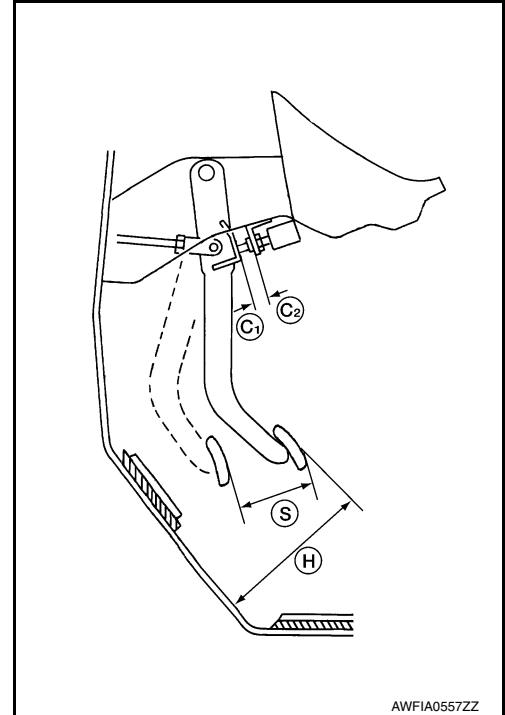

Unit: mm (in)

Brake Pedal Specifications	
Pedal free height (H)	Refer to BR-47, "Brake Pedal"
Pedal full stroke (S)	Refer to BR-47, "Brake Pedal"
Clearance between brake pedal bracket (C1) and threaded end of stop lamp switch and ASCD cancel switch [if equipped] (C2)	Refer to BR-47, "Brake Pedal"

ADJUSTMENT

1. Loosen the stop lamp switch and ASCD cancel switch (if equipped) by turning 45° counterclockwise.

BRAKE PEDAL

< PERIODIC MAINTENANCE >

- Loosen lock nut (A) on the input rod, then turn input rod to adjust the brake pedal to specified height. When finished adjusting, tighten lock nut (A) to specification.

Lock nut (A) : 18.7 N·m (1.9 kg·m, 14 ft·lb)

CAUTION:

Make sure that the screw portion of the end of input rod is located inside the clevis.

- With the brake pedal pulled up and held by hand, press the stop lamp switch and the ASCD cancel switch (if equipped) in until threaded ends contact the brake pedal bracket.
- With the threaded ends of the stop lamp switch and ASCD cancel switch (if equipped) contacting the pedal bracket, turn the switches 45° clockwise to lock in place. Check that the stop lamp switch and ASCD cancel switch (if equipped) threaded end to brake pedal bracket gap (C) is within specifications.

CAUTION:

Make sure that the gap (C) between the brake pedal bracket and stop lamp switch and ASCD cancel switch (if equipped) threaded ends are within specification.

- Check the brake pedal for smooth operation.

CAUTION:

Make sure that the stop lamp goes off when the brake pedal is released.

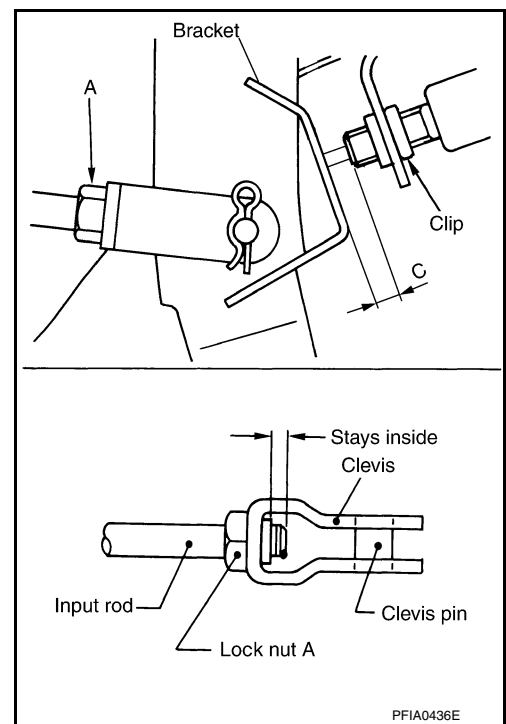

Inspection and Adjustment - Adjustable Pedal

INFOID:000000009883537

INSPECTION

- Inspect the brake pedal free height (H) from the floor using Tool at a 90° angle to the floor as shown.

CAUTION:

When equipped with adjustable pedal, the pedal must be in the forward most (closest to the floor) position for pedal height measurement.

Tool number : — (J-46532)

- Adjust the height referring to the following specifications.

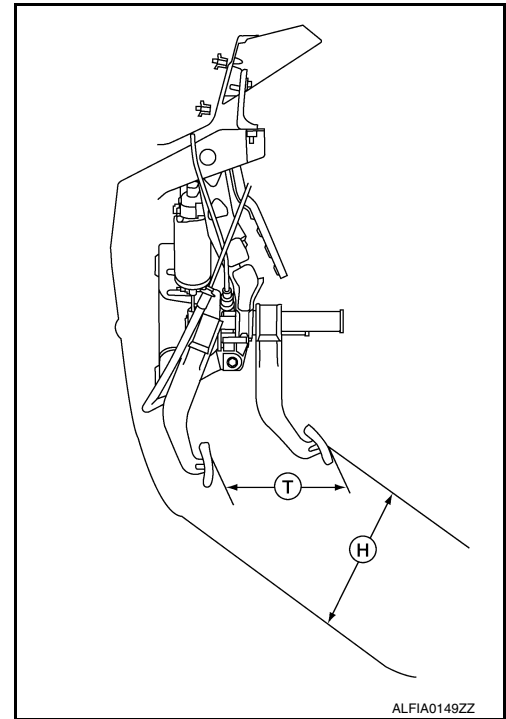

Brake Pedal Specifications

Unit: mm (in)

Pedal free height (H) with pedal in forward most position	Refer to BR-47. "Brake Pedal"
Pedal full stroke (T)	Refer to BR-47. "Brake Pedal"
Clearance between brake pedal bracket and threaded end of stop lamp switch and ASCD cancel switch	Refer to BR-47. "Brake Pedal"

BRAKE PEDAL

< PERIODIC MAINTENANCE >

ADJUSTMENT

1. Loosen the stop lamp switch and ASCD cancel switch by turning them 45° counterclockwise.
2. Loosen lock nut (A) on the input rod, then turn input rod to adjust the brake pedal to the specified height. When finished adjusting, tighten the lock nut (A) to specification.

Lock nut (A) : 18.7 N·m (1.9 kg-m, 14 ft-lb)

CAUTION:

Make sure that the screw portion of the end of input rod is located inside the clevis.

3. With the brake pedal pulled up and held by hand, press the stop lamp switch and the ASCD cancel switch in until the threaded ends contact the brake pedal bracket.
4. With the threaded ends of the stop lamp switch and ASCD cancel switch contacting the pedal bracket, turn the switches 45° clockwise to lock in place. Check that the stop lamp switch and ASCD cancel switch threaded end to brake pedal bracket gap (C) is within specifications.

CAUTION:

Make sure that the gap (C) between the brake pedal bracket and stop lamp switch and ASCD cancel switch threaded ends are within specification.

5. Check the brake pedal for smooth operation.

CAUTION:

Make sure that the stop lamp goes off when the brake pedal is released.

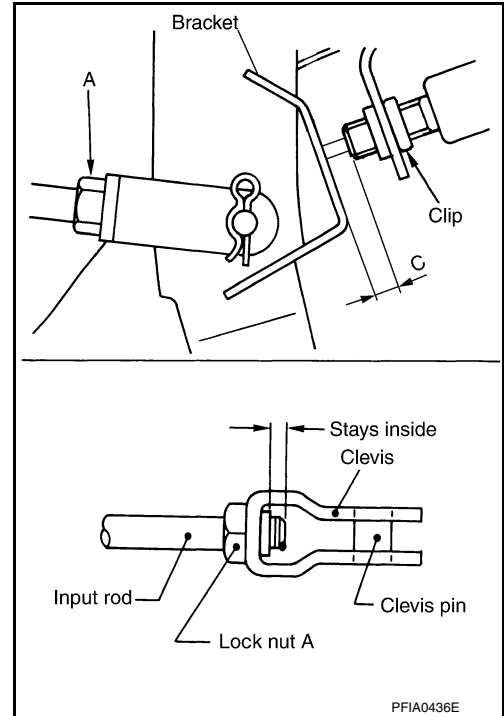

BRAKE FLUID

< PERIODIC MAINTENANCE >

BRAKE FLUID

On Board Inspection

INFOID:000000009883538

LEVEL CHECK

- Make sure the fluid level in reservoir tank is between MAX and MIN lines as shown.
- Visually check around reservoir tank for fluid leaks.
- If fluid level is excessively low, check brake system for leaks.
- If brake warning lamp remains illuminated after parking brake pedal is released, check brake system for fluid leaks.

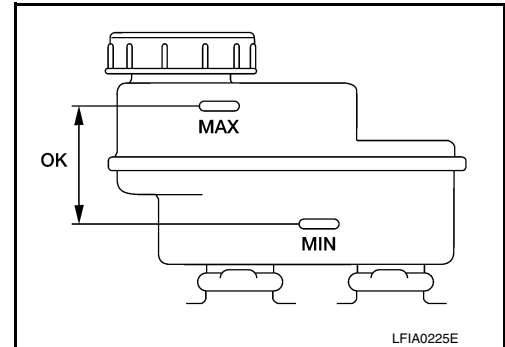

Drain and Refill

INFOID:000000009883539

CAUTION:

- Refill with new brake fluid. Refer to [GI-21, "Recommended Chemical Products and Sealants"](#).
- Do not reuse drained brake fluid.
- Do not let brake fluid splash on the painted surfaces of the body. This might damage the paint, so if splashing it, immediately wipe off the area and wash away with water.
- Before servicing, disconnect ABS actuator and electric unit (control unit) connector or battery negative terminal.

1. Turn ignition switch off and disconnect ABS actuator and electric unit (control unit) connector or battery negative cable.
2. Connect a vinyl tube to each bleed valve.
3. Depress brake pedal, loosen each bleed valve, and gradually remove brake fluid.

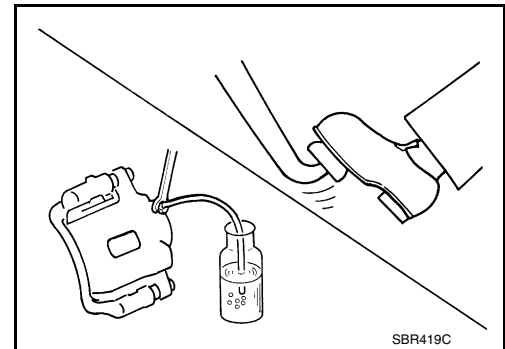

4. Make sure there is no foreign material in reservoir tank, and refill with new brake fluid.
5. Rest foot on brake pedal. Loosen bleed valve. Slowly depress pedal until it stops. Tighten bleed valve. Release brake pedal. Repeat this process a few times, then pause to add new brake fluid to master cylinder. Continue until new brake fluid flows out of the bleed valve. Bleed the air out of the brake hydraulic system. Refer to [BR-16, "Bleeding Brake System"](#).

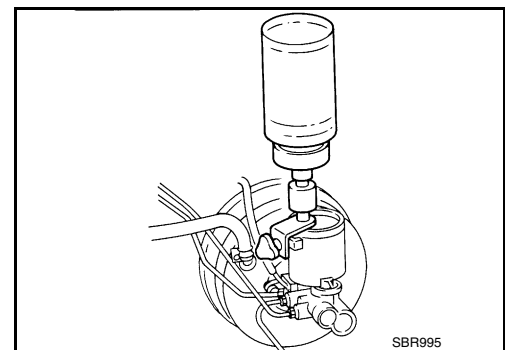

Bleeding Brake System

INFOID:000000009883540

CAUTION:

While bleeding, pay attention to master cylinder reservoir tank fluid level.

1. Turn ignition switch OFF and disconnect ABS actuator and electric unit (control unit) connector or battery negative cable.

BRAKE FLUID

< PERIODIC MAINTENANCE >

2. Connect a vinyl tube to the rear right bleed valve.
3. Fully depress brake pedal 4 to 5 times.
4. With brake pedal depressed, loosen bleed valve to let the air out, and then tighten it immediately.
5. Repeat steps 3 and 4 until no more air comes out.
6. Tighten bleed valve to the specified torque. Refer to [BR-32, "Exploded View of Brake Caliper"](#) (front disc brake), [BR-36, "Exploded View of Brake Caliper"](#) (rear disc brake).
7. Repeat steps 2 through 6 at each wheel, with master cylinder reservoir tank filled at least half way, bleeding air in order from the front left, rear left, and front right bleed valves.

A

B

C

D

E

BR

G

H

I

J

K

L

M

N

O

P

BRAKE PEDAL

< REMOVAL AND INSTALLATION >

REMOVAL AND INSTALLATION

BRAKE PEDAL

Exploded View

INFOID:000000009883541

Non-Adjustable Pedals

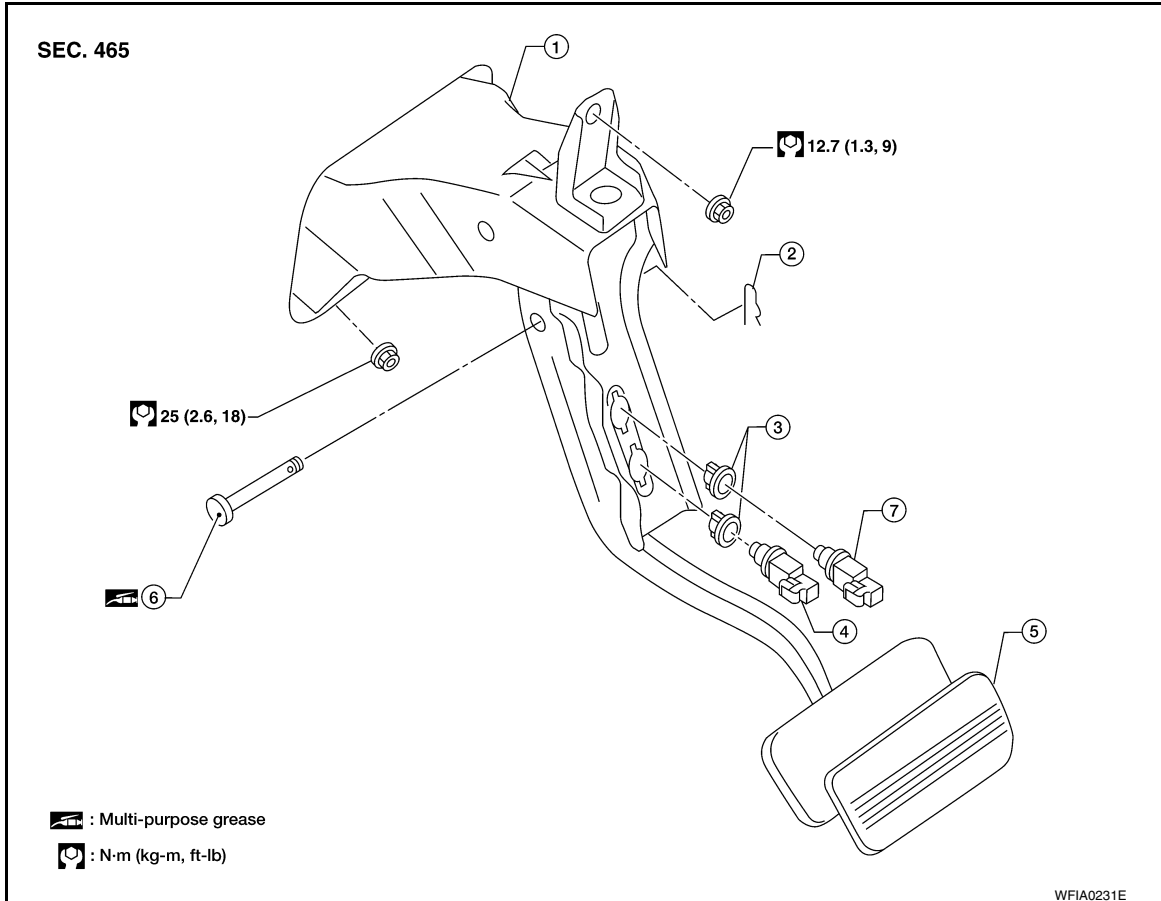

- | | | |
|-------------------------------------|--------------|---------------|
| 1. Brake pedal assembly | 2. Snap pin | 3. Clip |
| 4. Stop lamp switch | 5. Pedal pad | 6. Clevis pin |
| 7. ASCD cancel switch (if equipped) | | |

BRAKE PEDAL

< REMOVAL AND INSTALLATION >

Adjustable Pedals

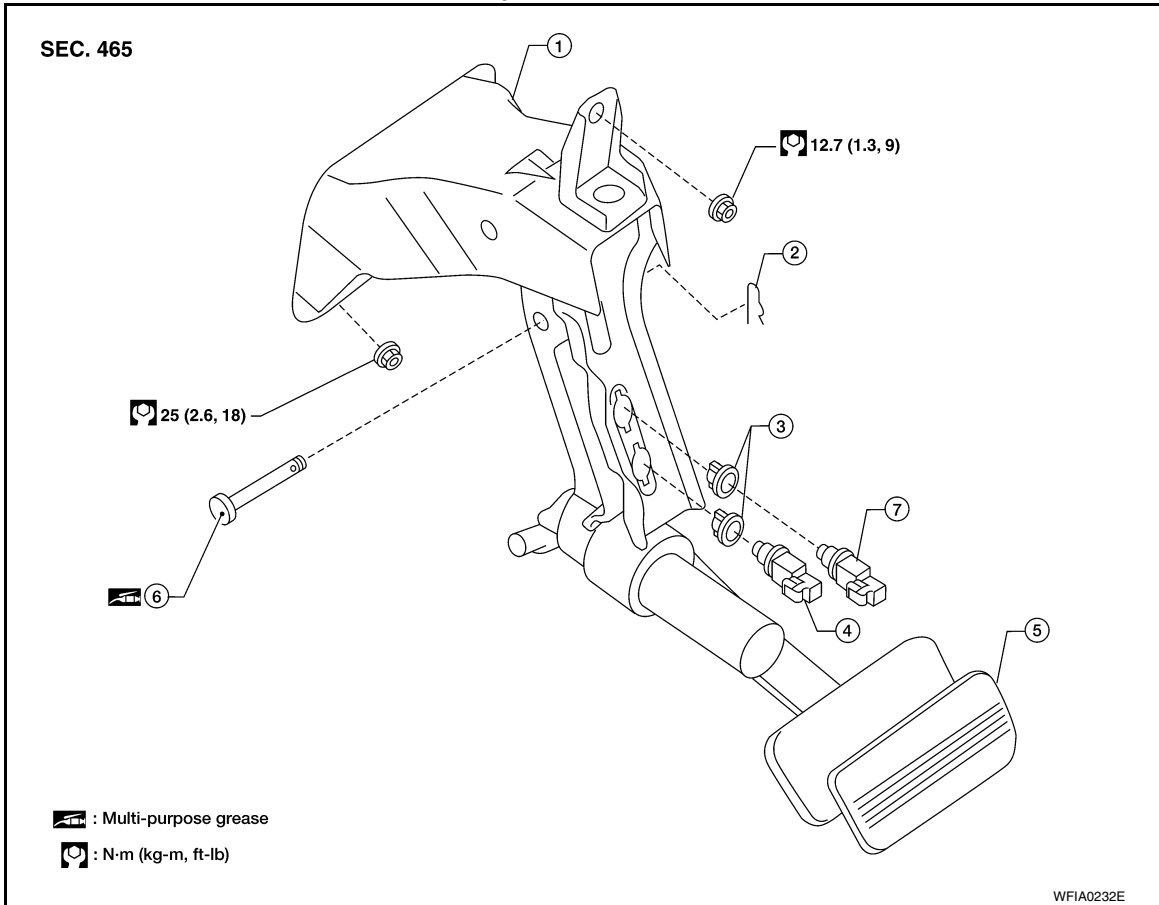

- | | | |
|-------------------------|--------------|---------------|
| 1. Brake pedal assembly | 2. Snap pin | 3. Clip |
| 4. Stop lamp switch | 5. Pedal pad | 6. Clevis pin |
| 7. ASCD cancel switch | | |

Removal and Installation

INFOID:000000009883542

REMOVAL

CAUTION:

- If equipped, before removal and installation, the accelerator and brake pedals must be in the forward most position (closest to the floor). This is to align the base position of the accelerator and brake pedals.
- If equipped, do not disassemble the brake pedal adjusting mechanism.
- Avoid damage from dropping the brake pedal assembly during handling.
- Keep the brake pedal assembly away from water.

1. Remove the lower instrument panel LH. Refer to [IP-17, "Removal and Installation"](#).
2. Remove the stop lamp switch and ASCD cancel switch (if equipped) from the pedal assembly.
3. If equipped, disconnect the adjustable brake pedal cable from the adjustable pedal electric motor.
 - Unlock (1) then pull (2) the adjustable brake pedal cable to disconnect it from the adjustable pedal electric motor as shown.

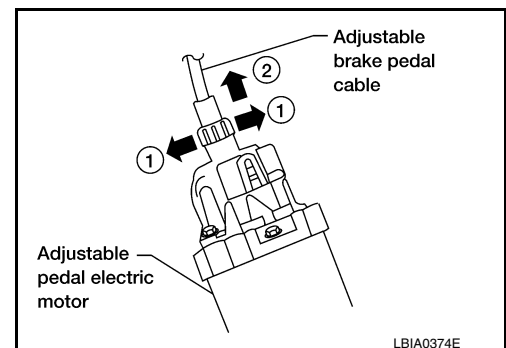

BRAKE PEDAL

< REMOVAL AND INSTALLATION >

4. Remove snap pin and clevis pin from the clevis of brake booster.
5. Remove nuts and the brake pedal assembly.
 - Temporarily install nuts by hand to support brake booster.

WARNING:

Do not deform the brake tube.

CAUTION:

- If equipped, before removal and installation the accelerator and brake pedals must be in the forward most position (closest to the floor). This is to align the base position of the accelerator and brake pedals.
- If equipped, do not disassemble the brake pedal adjusting mechanism.
- Avoid damage from dropping the brake pedal assembly during handling.
- Keep the brake pedal assembly away from water.

INSPECTION AFTER REMOVAL

Check the brake pedal assembly for the following items.

- Crack or deformation of clevis pin stopper
- Clevis pin deformation
- Crack of any welded portion of the brake pedal assembly
- Brake pedal bend or deformation

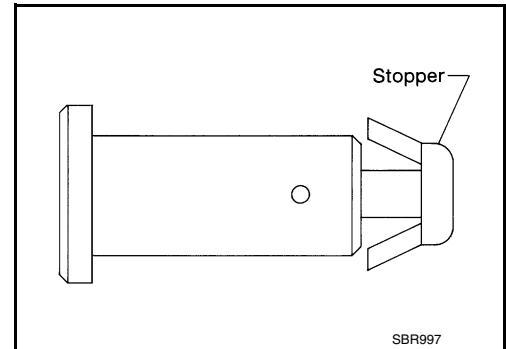

INSTALLATION

Installation is in the reverse order of removal.

- Check the brake pedal for smooth operation. There should be no binding or sticking when applying or releasing the brake pedal.
- Check the brake pedal adjustable feature for smooth operation. There should be no binding or sticking when adjusting the brake pedal forward or backward.
- After installing the brake pedal assembly, be sure to adjust it. Refer to [BR-13, "Inspection and Adjustment - Standard Pedal"](#), [BR-14, "Inspection and Adjustment - Adjustable Pedal"](#).

BRAKE TUBE AND HOSE

< REMOVAL AND INSTALLATION >

BRAKE TUBE AND HOSE

Hydraulic Circuit

INFOID:000000009883543

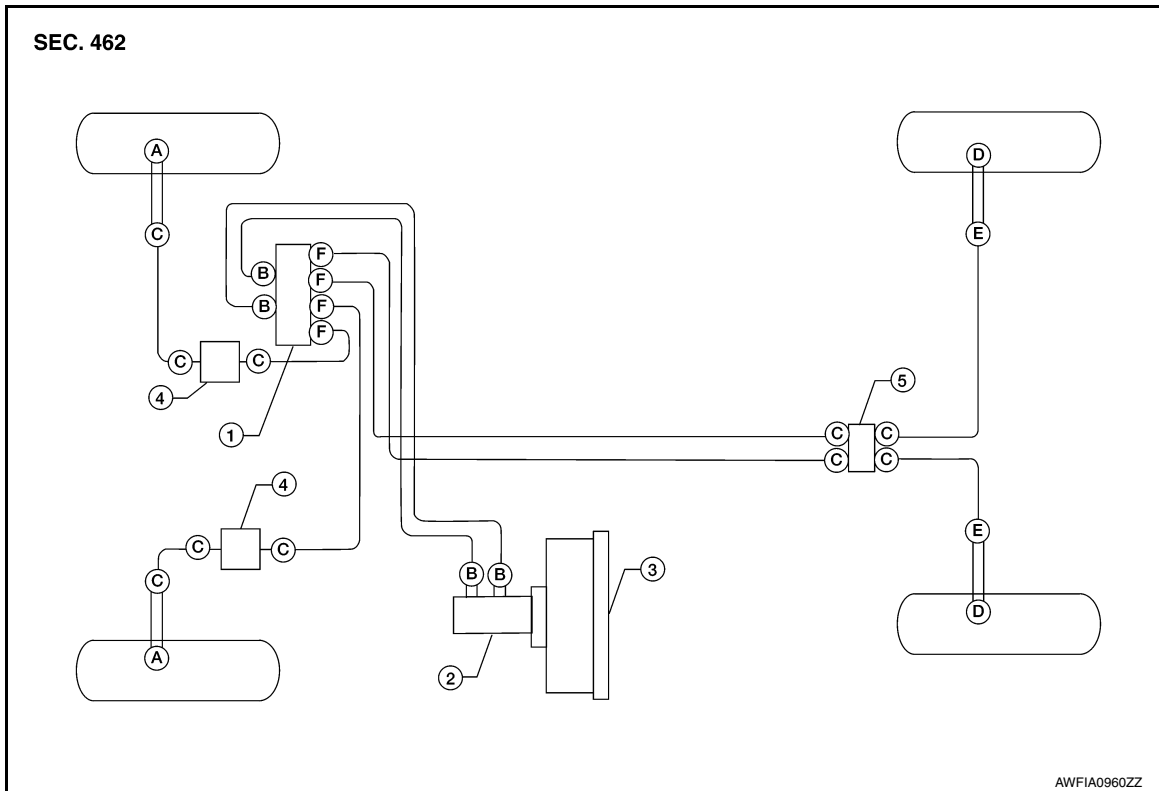

- | | | |
|--|--|--|
| 1. Actuator | 2. Master cylinder | 3. Brake booster |
| 4. Connector | 5. Axle mounted connector
9.3 N·m (0.95 kg-m, 82 in-lb) | A. Union bolt (front caliper)
18.2 N·m (1.9 kg-m, 13 ft-lb) |
| B. Flare nut M12
18.2 N·m (1.9 kg-m, 13 ft-lb) | C. Flare nut M10
16.2 N·m (1.7 kg-m, 12 ft-lb) | D. Hose connection (rear caliper)
18.2 N·m (1.9 kg-m, 13 ft-lb) |
| E. Flare nut to rear hose
16.2 N·m (1.7 kg-m, 12 ft-lb) | F. Flare nut M10
13.0 N·m (1.3 kg-m, 10 ft-lb) | — Brake line |
| = Brake hose | | |

CAUTION:

- All hoses and piping (tubes) must be free from excessive bending, twisting and pulling.
- Make sure there is no interference with other parts when turning the steering wheel both clockwise and counterclockwise.
- The brake piping is an important safety part. If a brake fluid leak is detected, always disassemble the parts. Replace applicable part with a new one, if necessary.
- Be careful not to splash brake fluid on painted areas; it may cause paint damage. If brake fluid is splashed on painted areas, wash it away with water immediately.
- Do not bend or twist brake hose sharply, or strongly pull it.
- Refill with new specified brake fluid. Refer to [MA-15, "FOR NORTH AMERICA : Fluids and Lubricants"](#) (United States and Canada), [MA-16, "FOR MEXICO : Fluids and Lubricants"](#) (Mexico).
- Do not reuse drained brake fluid.

Removal and Installation of Front Brake Piping and Brake Hose

INFOID:000000009883544

NOTE:

When removing components such as hoses, tubes/lines, etc., cap or plug openings to prevent fluid from spilling.

REMOVAL

1. Remove front wheel and tire using power tools.

BRAKE TUBE AND HOSE

< REMOVAL AND INSTALLATION >

2. Remove brake reservoir cap.
3. Remove brake tube from brake hose, using a suitable tool.
4. Remove lock plate and brake hose from bracket.

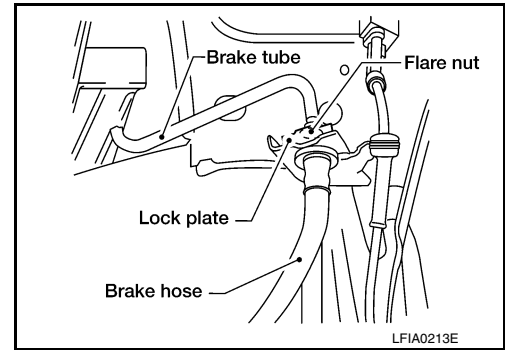

5. Remove union bolt and then remove brake hose from cylinder body.

CAUTION:

Do not reuse copper sealing washer.

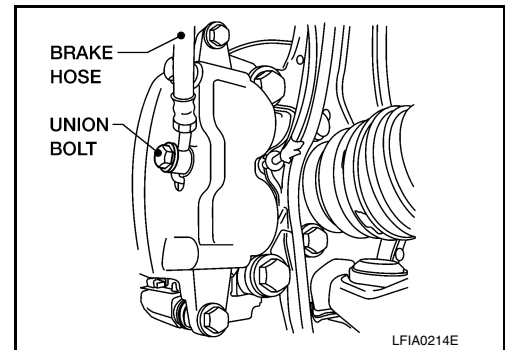

INSTALLATION

1. Install brake hose by aligning with the protrusion on cylinder body, then install the union bolt (A) and new copper sealing washers (1) and tighten to specification. Refer to [BR-21, "Hydraulic Circuit"](#).

CAUTION:

Do not reuse copper sealing washers.

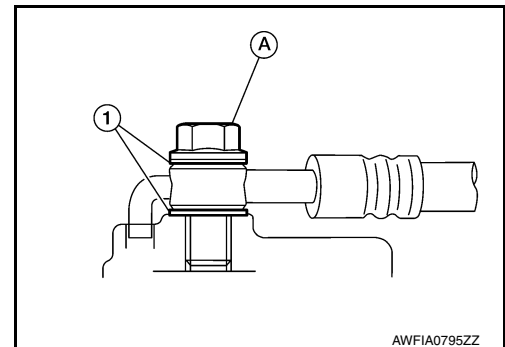

2. Insert brake hose end through bracket, then secure it to bracket with lock plate.
3. Install brake tube to brake hose, then tighten the flare nut using a suitable tool. Refer to [BR-21, "Hydraulic Circuit"](#).

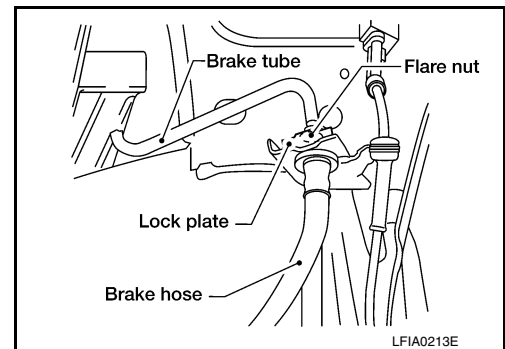

4. Refill brake fluid and bleed air. Refer to [BR-16, "Bleeding Brake System"](#).
5. Install wheel and tire assembly. Refer to [WT-48, "Balancing Wheels"](#).

Removal and Installation of Rear Brake Piping and Brake Hose

INFOID:000000009883545

NOTE:

When removing components such as hoses, tubes/lines, etc., cap or plug openings to prevent fluid from spilling.

BRAKE TUBE AND HOSE

< REMOVAL AND INSTALLATION >

REMOVAL

1. Remove rear wheel and tire assembly using power tools. Refer to [WT-48. "Balancing Wheels"](#).
2. Remove brake reservoir cap.
3. Using a flare nut wrench, remove brake tube from brake hose.
4. Remove lock plate and brake hose from bracket.

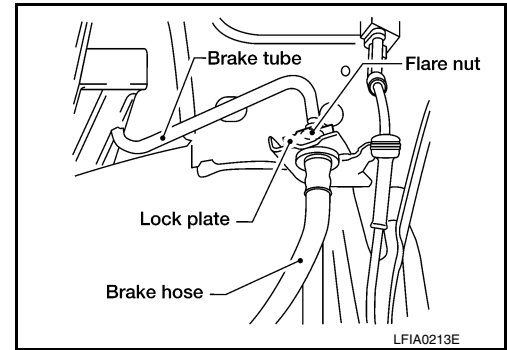

5. Remove brake hose connection (A) from cylinder body.
CAUTION:
Do not reuse copper sealing washer.

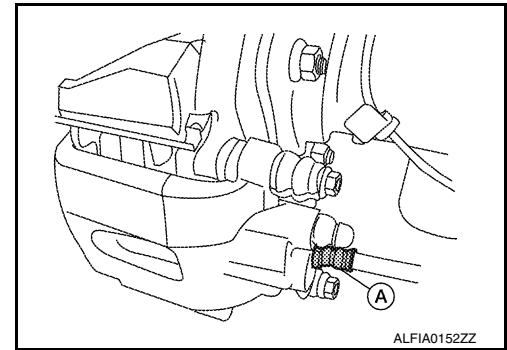

INSTALLATION

1. Install brake hose connection (A) and new copper sealing washer to cylinder body and tighten to specification. Refer to [BR-11. "Hydraulic Circuit"](#).
CAUTION:
Do not reuse copper sealing washer.

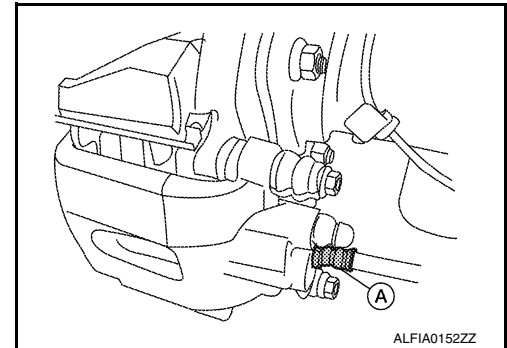

2. Insert brake hose end through bracket, then secure it to bracket with lock plate.
3. Install brake tube to brake hose, then tighten the flare nut using a suitable tool. Refer to [BR-11. "Hydraulic Circuit"](#).

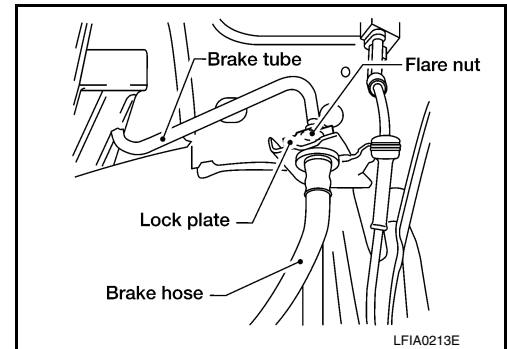

4. Refill brake fluid and bleed air. Refer to [BR-16. "Bleeding Brake System"](#).

Inspection After Installation

INFOID:000000009883546

CAUTION:

BRAKE TUBE AND HOSE

< REMOVAL AND INSTALLATION >

Brake tubes and hoses are important safety parts. Always disassemble the parts and retighten their fittings, if a brake fluid leak is detected. Replace applicable part with a new one, if a damaged part is detected.

1. Check brake lines (tubes and hoses), and connections for fluid leaks, damage, twist, deformation, contact with other parts, and loose connections. Replace any parts as necessary. Refer to [BR-21, "Hydraulic Circuit"](#).
2. While depressing brake pedal under a force of 785 N (80 kg-f, 177 lb-f) with engine running for approximately 5 seconds, check each part for fluid leaks.

BRAKE MASTER CYLINDER

< REMOVAL AND INSTALLATION >

BRAKE MASTER CYLINDER

Exploded View

INFOID:000000009883547

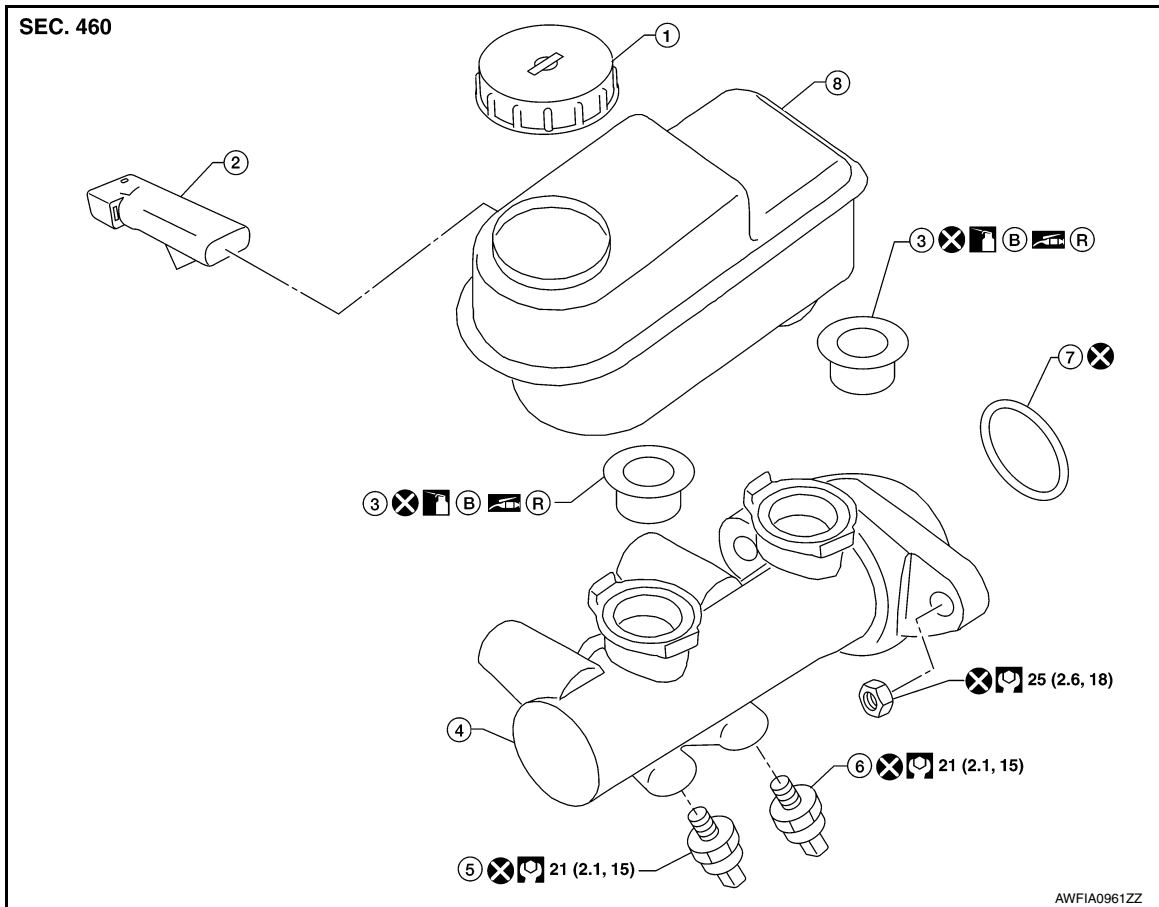

- | | | |
|---------------------------------|-------------------------|--------------------------|
| 1. Reservoir cap | 2. Fluid level sensor | 3. Grommet |
| 4. Master cylinder sub-assembly | 5. Rear pressure sensor | 6. Front pressure sensor |
| 7. Seal | 8. Reservoir tank | B: Brake fluid |
| | | R: Rubber grease |

Removal and Installation

INFOID:000000009883548

CAUTION:

- Be careful not to splash brake fluid on painted areas; it may cause paint damage. If brake fluid is splashed on painted areas, wash it away with water immediately.
- Before removing brake master cylinder, depress the brake pedal 5-6 times with the key OFF to deplete vacuum in the booster.

NOTE:

When removing components such as hoses, tubes/lines, etc., cap or plug openings to prevent fluid from spilling.

REMOVAL

1. Remove brake reservoir cap.
2. Disconnect harness connector for fluid level sensor, front and rear pressure sensors.
3. Using a flare nut wrench, disconnect brake tubes from master cylinder assembly.
4. Remove master cylinder assembly nuts and remove the master cylinder assembly.

CAUTION:

Discard master cylinder nuts, do not reuse.

BRAKE MASTER CYLINDER

< REMOVAL AND INSTALLATION >

INSTALLATION

Installation is in the reverse order of removal.

- Refill brake fluid and bleed air. Refer to [BR-16, "Bleeding Brake System"](#).

CAUTION:

- **Be careful not to splash brake fluid on painted areas; it may cause paint damage. If brake fluid is splashed on painted areas, wash it away with water immediately.**
- **Refill with new brake fluid. Refer to [MA-15, "FOR NORTH AMERICA : Fluids and Lubricants"](#) (United States and Canada), [MA-16, "FOR MEXICO : Fluids and Lubricants"](#) (Mexico).**
- **Do not reuse drained brake fluid.**
- **Discard master cylinder nuts. Do not reuse.**
- Adjust brake pedal. Refer to [BR-13, "Inspection and Adjustment - Standard Pedal"](#), [BR-14, "Inspection and Adjustment - Adjustable Pedal"](#).

BRAKE BOOSTER

< REMOVAL AND INSTALLATION >

BRAKE BOOSTER

Removal and Installation

INFOID:00000009883549

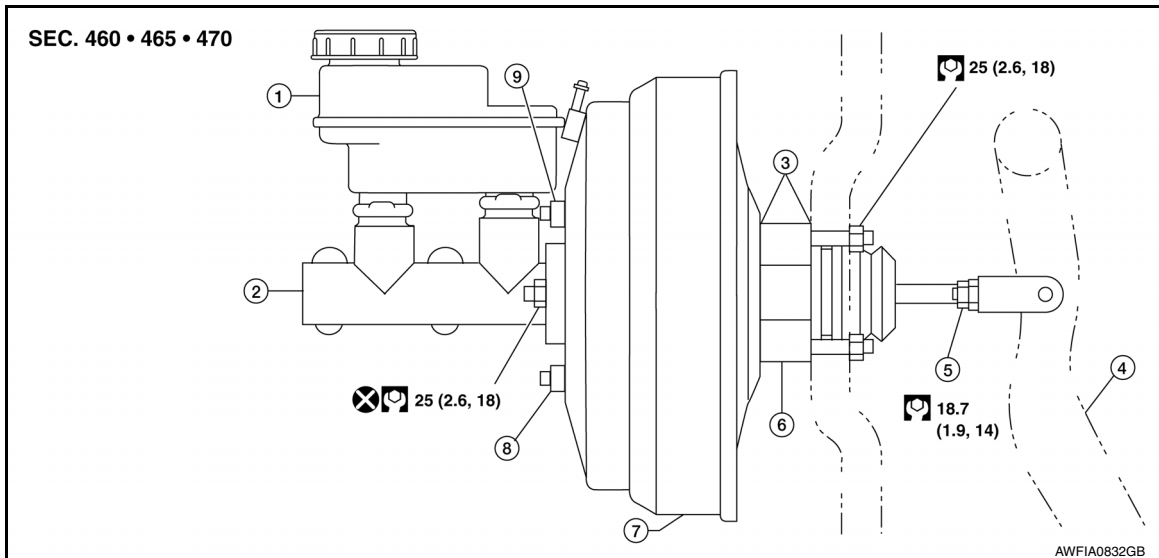

- | | | |
|-------------------|-----------------------------|------------------------|
| 1. Reservoir tank | 2. Master cylinder assembly | 3. Gasket |
| 4. Brake pedal | 5. Lock nut | 6. Spacer block |
| 7. Brake booster | 8. Active booster | 9. Delta stroke sensor |

CAUTION:

- Be careful not to deform or bend brake piping while removing and installing brake booster.
- Replace clevis pin if it is damaged.
- Be careful not to damage brake booster stud bolt threads. If brake booster is tilted or inclined during installation, dash panel may damage the threads.
- Attach the check valve in the correct direction.

REMOVAL

1. Remove air duct and resonator assembly. Refer to [EM-26, "Removal and Installation"](#).
2. Remove cowl top extension. Refer to [EXT-21, "Removal and Installation"](#).
3. Remove master cylinder assembly from brake booster. Refer to [BR-25, "Removal and Installation"](#).
4. Remove vacuum hose from brake booster. Refer to [BR-29, "Removal and Installation"](#).
5. Disconnect active booster and delta stroke sensor harness connectors from brake booster.
6. Remove the instrument lower panel LH. Refer to [IP-17, "Removal and Installation"](#).
7. Remove brake pedal to clevis attachment snap pin and clevis pin from inside the vehicle.
8. Remove brake booster to brake pedal assembly nuts.
9. Reposition the A/C line out of the way.
10. Remove brake booster and spacer block from dash panel.

INSPECTION AFTER REMOVAL

Output Rod Length Inspection

BRAKE BOOSTER

< REMOVAL AND INSTALLATION >

1. Using a hand vacuum pump, apply a vacuum of -66.7 kPa (-500 mm Hg, -19.69 in Hg) to brake booster.
2. Check output rod length.

Output rod length : Refer to [BR-25, "Exploded View"](#).

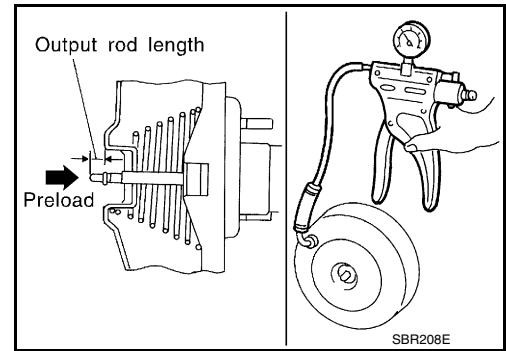

INSTALLATION

1. Loosen lock nut to adjust input rod length so that the length (B) is set at the specified value.

Input rod length (B) : Refer to [BR-27, "Removal and Installation"](#).

2. After adjusting length (B), temporarily tighten lock nut and install brake booster and spacer block.
 - Install the gaskets and spacer block between brake booster and dash panel.
3. Connect brake pedal to clevis on the input rod.
4. Install brake booster to brake pedal assembly nuts and tighten to the specified torque.
5. Connect active booster and delta stroke sensor harness connectors to brake booster.
6. Connect vacuum hose to brake booster.
7. Install master cylinder assembly to brake booster. Refer to [BR-25, "Removal and Installation"](#).
8. Adjust the height and play of brake pedal. Refer to [BR-13, "Inspection and Adjustment - Standard Pedal"](#), [BR-14, "Inspection and Adjustment - Adjustable Pedal"](#).
9. Tighten lock nut of input rod to specification.
10. Install the instrument lower panel LH. Refer to [IP-17, "Removal and Installation"](#).
11. Secure A/C line into clips.
12. Install cowl top extension. Refer to [EXT-21, "Removal and Installation"](#).
13. Install air duct and resonator assembly. Refer to [EM-26, "Removal and Installation"](#).
14. Refill with new brake fluid and bleed air. Refer to [BR-16, "Bleeding Brake System"](#).

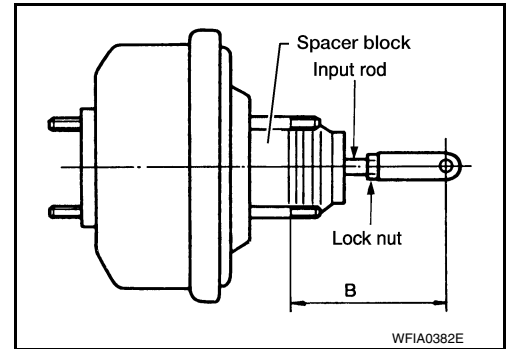

VACUUM LINES

< REMOVAL AND INSTALLATION >

VACUUM LINES

Removal and Installation

INFOID:00000009883550

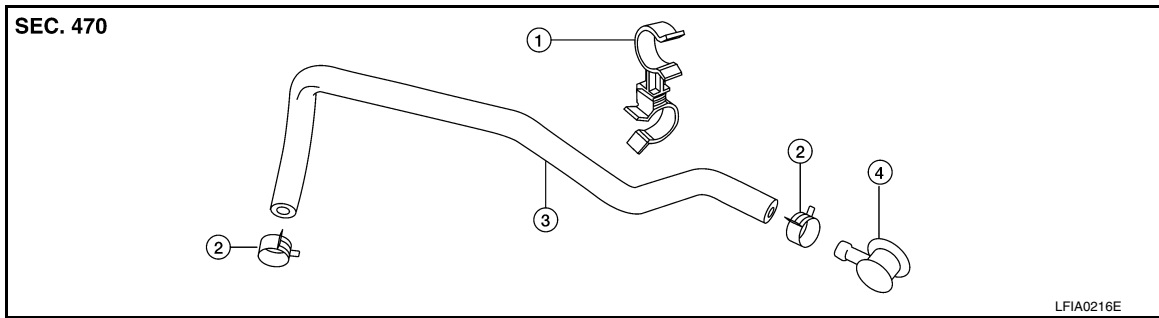

1. Hose clip
2. Clamp
3. Vacuum hose
4. Check valve

REMOVAL

1. Remove engine room cover.
2. Disconnect vacuum hose from hose clip.
3. Release clamps and disconnect vacuum hose.
4. Remove check valve from brake booster.

INSTALLATION

Installation is in the reverse order of removal.

CAUTION:

- Insert vacuum hose over the tube at least 24 mm (0.94 in).
- Do not use lubricating oil during assembly.

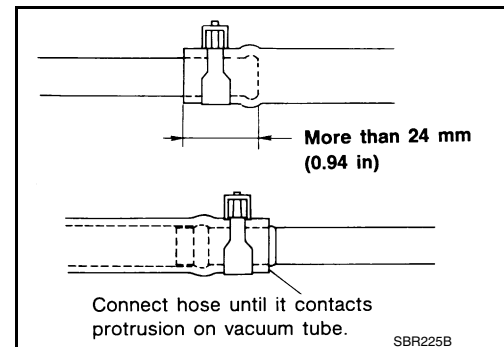

FRONT DISC BRAKE

< REMOVAL AND INSTALLATION >

FRONT DISC BRAKE

Exploded View of Brake Pads

INFOID:000000009883551

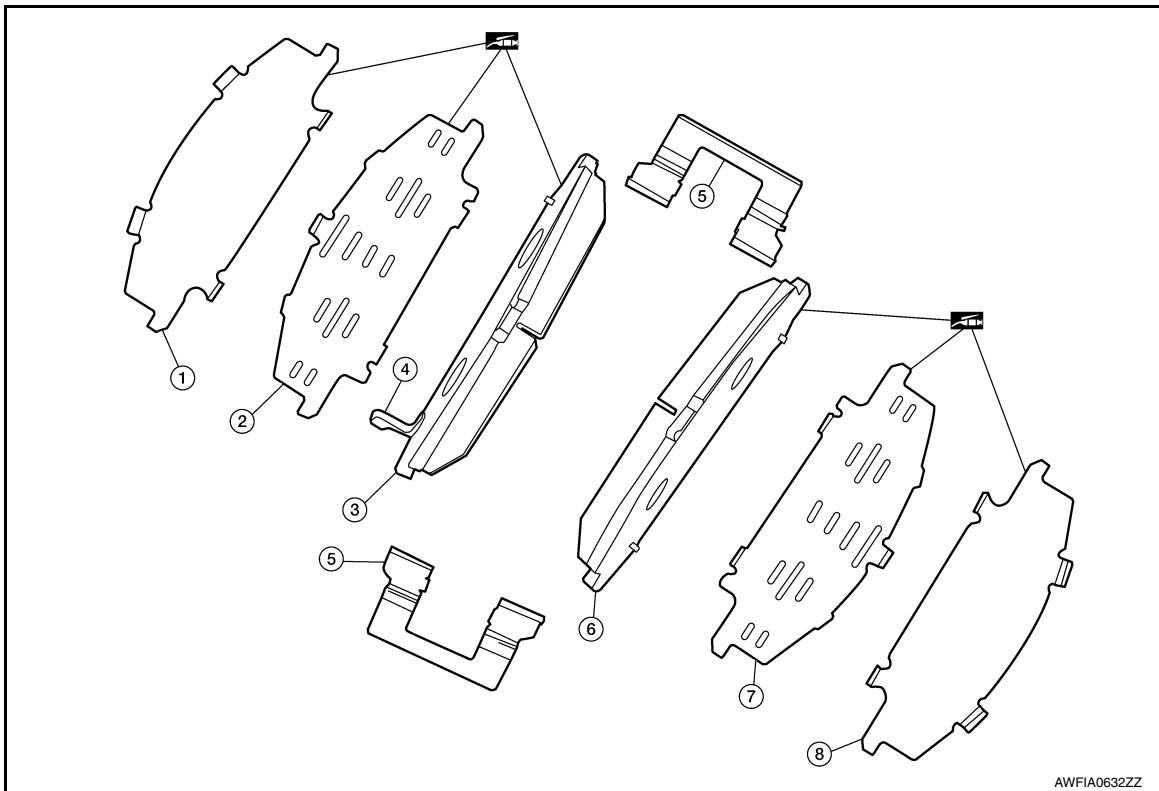

- | | | |
|---------------------|---------------------|---|
| 1. Inner shim cover | 2. Inner shim | 3. Inner pad |
| 4. Pad wear sensor | 5. Pad retainers | 6. Outer pad |
| 7. Outer shim | 8. Outer shim cover |  Molykote AS-880N grease |

Removal and Installation of Brake Pads

INFOID:000000009883552

WARNING:

Clean dust on caliper and brake pads with a vacuum dust collector to minimize the hazard of air borne particles or other materials.

CAUTION:

- While removing cylinder body, do not depress brake pedal because piston will pop out.
- It is not necessary to remove bolts on torque member and brake hose except for disassembly or replacement of caliper assembly. In this case, hang cylinder body with a wire so as not to stretch brake hose.
- Do not damage piston boot.
- If any shim is subject to serious corrosion, replace it with a new one.
- Always replace shims and shim covers as a set when replacing brake pads.
- Keep rotor free from brake fluid.
- Burnish the brake pads and disc rotor mutually contacting surfaces, after refinishing or replacing rotors, after replacing pads, or if a soft pedal occurs at very low mileage. Refer to [BR-31, "Brake Burnishing Procedure"](#).

REMOVAL

1. Partially drain brake fluid. Refer to [BR-16, "Drain and Refill"](#).
2. Remove front wheels and tires using power tool.
3. Remove lower sliding pin bolts.

FRONT DISC BRAKE

< REMOVAL AND INSTALLATION >

4. Hang cylinder body with a wire, remove pads, pad retainers, shims, and shim covers from torque member.

CAUTION:

When removing the pad retainer from the torque member, lift it in the direction indicated by the arrow as shown so that it does not deform.

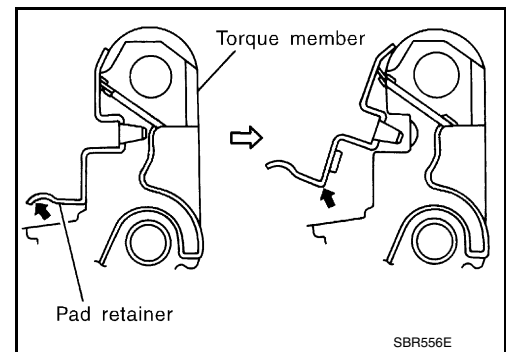

INSTALLATION

1. Push piston in using suitable tool.

CAUTION:

In the case of replacing a pad with new one, check the brake fluid level in the reservoir tank because brake fluid returns to reservoir tank when pressing piston in.

2. Apply Molykote AS-880N grease or equivalent to between shim cover and shim. Install inner shim, inner shim cover to inner pad, and install outer shim, outer shim cover to outer pad.
3. Install pad retainers and pads to torque member.

CAUTION:

- **Securely assemble pad retainers so that they are not being lifted up from torque member.**
- **Both inner and outer pads have a pad return system on the pad retainer. Install pad return lever securely to pad wear sensor.**

4. Install cylinder body to torque member.
5. Install sliding pin bolts, and tighten it to the specified torque.
6. Check front disc brake for drag and correct as necessary.
7. Install front wheels and tires. Refer to [WT-49. "Rotation"](#).
8. Refill with new brake fluid and check level. Refer to [BR-16. "On Board Inspection"](#).

Brake Burnishing Procedure

INFOID:000000009883553

Burnish contact surfaces between disc rotors and pads according to following procedure after refinishing or replacing rotors, after replacing pads, or if a soft pedal occurs at very low mileage.

CAUTION:

- **Be careful of vehicle speed because the brake does not operate easily until pad and disc rotor are securely seated.**
 - **Only perform this procedure under safe road and traffic conditions. Use extreme caution.**
1. Drive vehicle on straight, flat road.
 2. Depress brake pedal with the power to stop vehicle within 3 to 5 seconds until the vehicle stops.
 3. Drive without depressing brake for a few minutes to cool the brake.
 4. Repeat steps 1 through 3 until pad and disc rotor are securely seated.

FRONT DISC BRAKE

< REMOVAL AND INSTALLATION >

Exploded View of Brake Caliper

INFOID:00000009883554

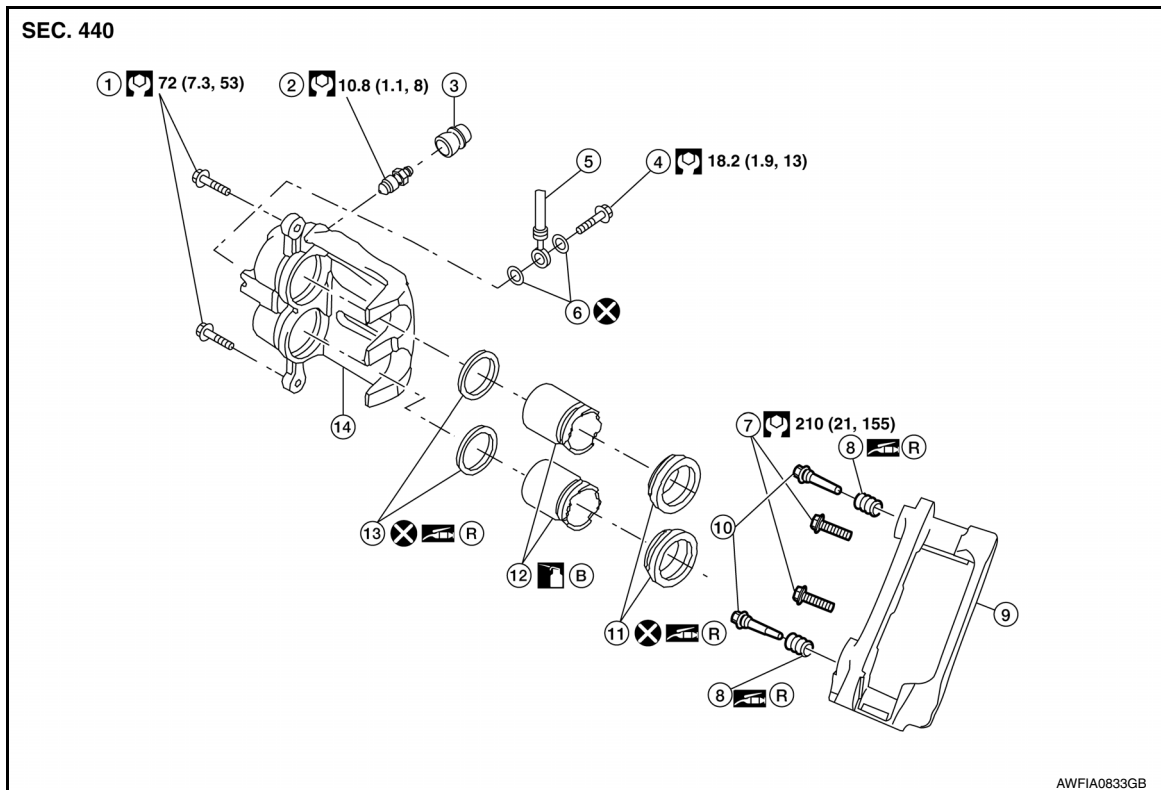

- | | | |
|-----------------------|---------------------|--------------------------|
| 1. Sliding pin bolt | 2. Bleed valve | 3. Cap |
| 4. Union bolt | 5. Brake hose | 6. Copper sealing washer |
| 7. Torque member bolt | 8. Sliding pin boot | 9. Torque member |
| 10. Sliding pin | 11. Piston boot | 12. Piston |
| 13. Piston seal | 14. Cylinder body | B: Brake fluid |
| R: Rubber grease | | |

Removal and Installation of Brake Caliper and Rotor

INFOID:00000009883555

WARNING:

Clean dust on caliper and brake pad with a vacuum dust collector to minimize the hazard of air borne particles or other materials.

CAUTION:

- While removing cylinder body, do not depress brake pedal because piston will pop out.
- It is not necessary to remove bolts on torque member and brake hose except for disassembly or replacement of caliper assembly. In this case, hang cylinder body with a wire so as not to stretch brake hose.
- Do not damage piston boot.
- If any shim is subject to serious corrosion, replace it with a new one.
- Always replace shim and shim cover as a set when replacing brake pads.
- Keep rotor free from brake fluid.
- Burnish the brake pads and disc rotor mutually contacting surfaces, after refinishing or replacing rotors, after replacing pads, or if a soft pedal occurs at very low mileage.

NOTE:

When removing components such as hoses, tubes/lines, etc., cap or plug openings to prevent fluid from spilling.

REMOVAL

1. Remove front wheels and tires using power tool.
2. Fasten disc rotor using wheel nut.

FRONT DISC BRAKE

< REMOVAL AND INSTALLATION >

3. Drain brake fluid. Refer to [CO-11, "Changing Engine Coolant"](#).
4. Remove union bolt (A), copper sealing washers (1), and brake hose from caliper assembly.

CAUTION:

Do not reuse copper sealing washers.

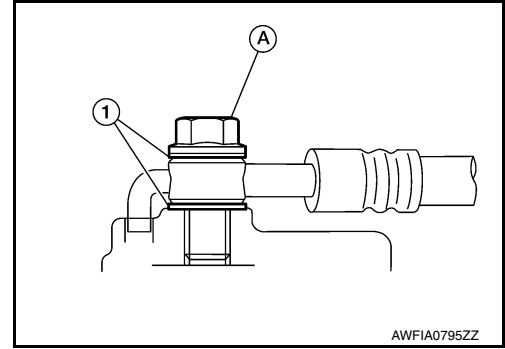

5. Remove torque member bolts, and remove brake caliper assembly.

CAUTION:

Do not drop brake pads.

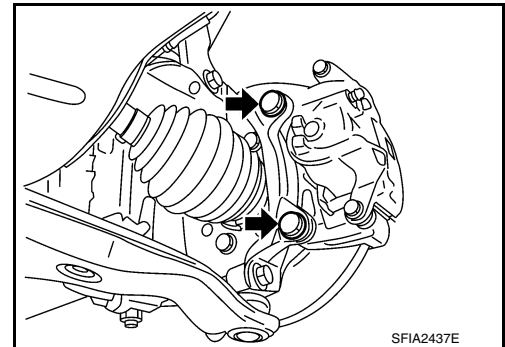

6. Apply matching marks to disc rotor and wheel hub assembly as shown if the disc rotor is to be reused, then remove disc rotor.

CAUTION:

Put matching marks on wheel hub assembly and disc rotor if the disc rotor is to be reused.

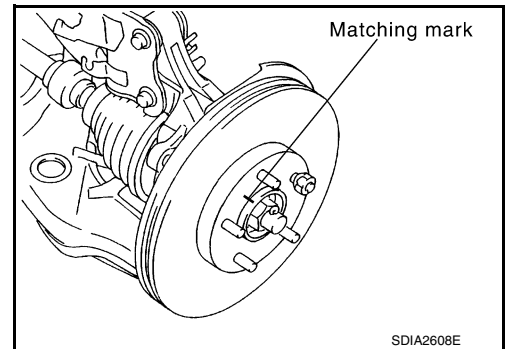

INSTALLATION

1. If reusing the disc rotor, use the matching marks to align disc rotor on the wheel hub assembly as shown, then install disc rotor using a wheel nut to hold it in place.

CAUTION:

Use matching marks on wheel hub assembly and disc rotor if the disc rotor is to be reused.

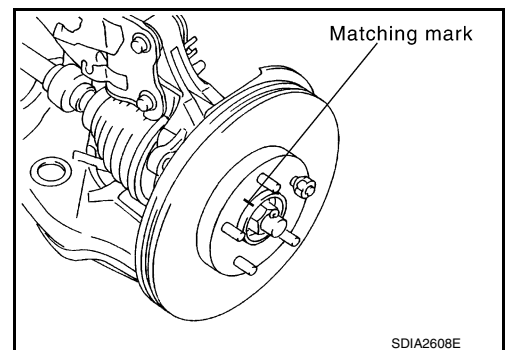

A
B
C
D
E
BR
G
H
I
J
K
L
M
N
O
P

FRONT DISC BRAKE

< REMOVAL AND INSTALLATION >

2. Install brake caliper assembly, and tighten torque member bolts to the specified torque.

CAUTION:

Do not allow oil or any moisture on all contact surfaces between steering knuckle and caliper assembly, bolts, and washers.

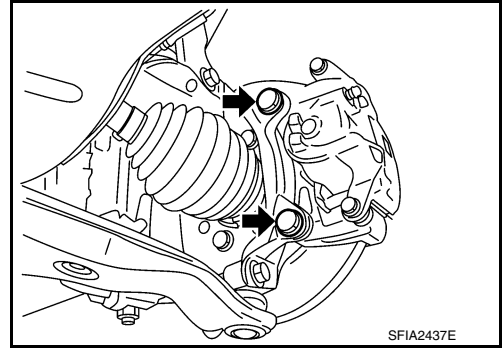

3. Install brake hose to brake caliper assembly using new copper sealing washers. Align the brake hose to the projection as shown and tighten union bolt to the specified torque.

CAUTION:

Do not reuse copper sealing washers.

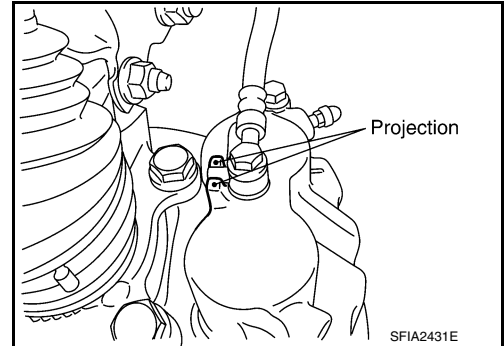

4. Refill with new brake fluid and bleed air. Refer to [BR-16. "Drain and Refill"](#).
5. Check front disc brake for drag and correct as necessary.
6. Install front wheels and tires. Refer to [WT-49. "Rotation"](#).

REAR DISC BRAKE

< REMOVAL AND INSTALLATION >

REAR DISC BRAKE

Exploded View of Brake Pads

INFOID:000000009883556

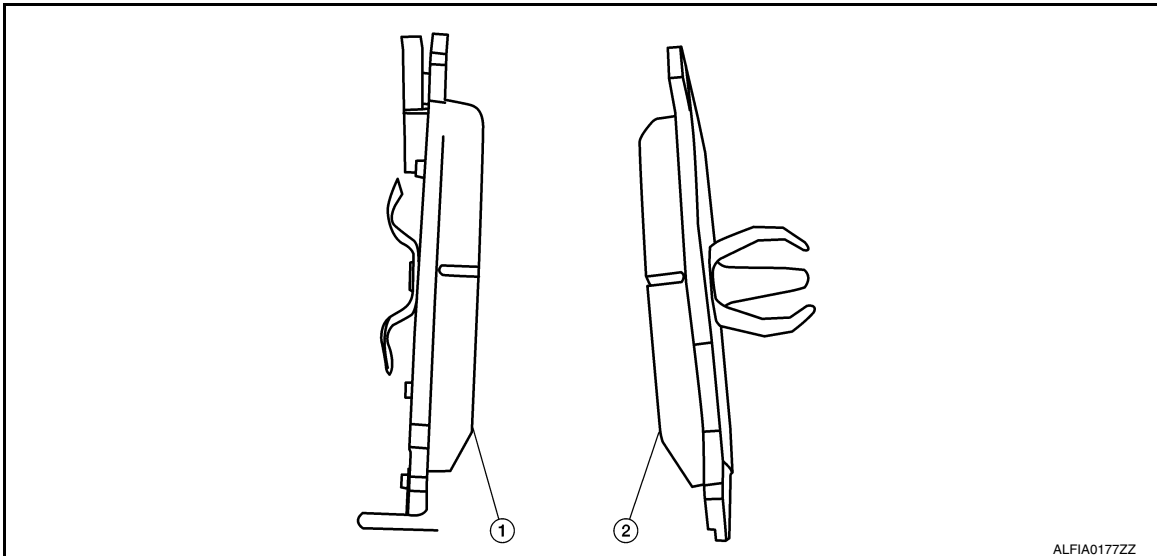

1. Outer pad

2. Inner pad

Removal and Installation of Brake Pad

INFOID:000000009883557

WARNING:

Clean dust on caliper and brake pad with a vacuum dust collector to minimize the hazard of air borne particles or other materials.

CAUTION:

- While removing cylinder body, do not depress brake pedal because piston will pop out.
- It is not necessary to remove bolts on torque member and brake hose except for disassembly or replacement of caliper assembly. In this case, hang cylinder body with a wire so as not to stretch brake hose.
- Do not damage piston boot.
- If any shim is subject to serious corrosion, replace it with a new one.
- Always replace shim and shim cover as a set when replacing brake pads.
- Keep rotor free from brake fluid.
- Burnish the brake pads and disc rotor mutually contacting surfaces, after refinishing or replacing rotors, after replacing pads, or if a soft pedal occurs at very low mileage. Refer to [BR-31, "Brake Burnishing Procedure"](#).

REMOVAL

1. Partially drain the brake fluid. Refer to [BR-16, "Drain and Refill"](#).
2. Remove rear wheels and tires using power tool.
3. Remove the sliding pin bolts.
4. Remove the cylinder body from the torque member, hang cylinder body with wire and remove pads.

INSTALLATION

1. Push piston in using a suitable tool.
CAUTION:
By pushing in piston, brake fluid returns to master cylinder reservoir tank. Watch the brake fluid level in the reservoir tank.
2. Apply Molykote 7439 grease to brake pad contact areas on knuckle.
CAUTION:
Do not get grease on the brake pads or brake rotor friction surfaces.
3. Install pads to cylinder body.

REAR DISC BRAKE

< REMOVAL AND INSTALLATION >

4. Install cylinder body to torque member.
5. Install sliding pin bolts and tighten to specification.
6. Check rear disc brake for drag and correct as necessary.
7. Install rear wheel and tires. Refer to [WT-49, "Rotation"](#).
8. Check brake fluid level. Refer to [BR-16, "On Board Inspection"](#).

Brake Burnishing Procedure

INFOID:000000009883558

Burnish contact surfaces between disc rotors and pads according to following procedure after refinishing or replacing rotors, after replacing pads, or if a soft pedal occurs at very low mileage.

CAUTION:

- Be careful of vehicle speed because the brake does not operate easily until pad and disc rotor are securely seated.
 - Only perform this procedure under safe road and traffic conditions. Use extreme caution.
1. Drive vehicle on straight, flat road.
 2. Depress brake pedal with the power to stop vehicle within 3 to 5 seconds until the vehicle stops.
 3. Drive without depressing brake for a few minutes to cool the brake.
 4. Repeat steps 1 through 3 until pad and disc rotor are securely seated.

Exploded View of Brake Caliper

INFOID:000000009883559

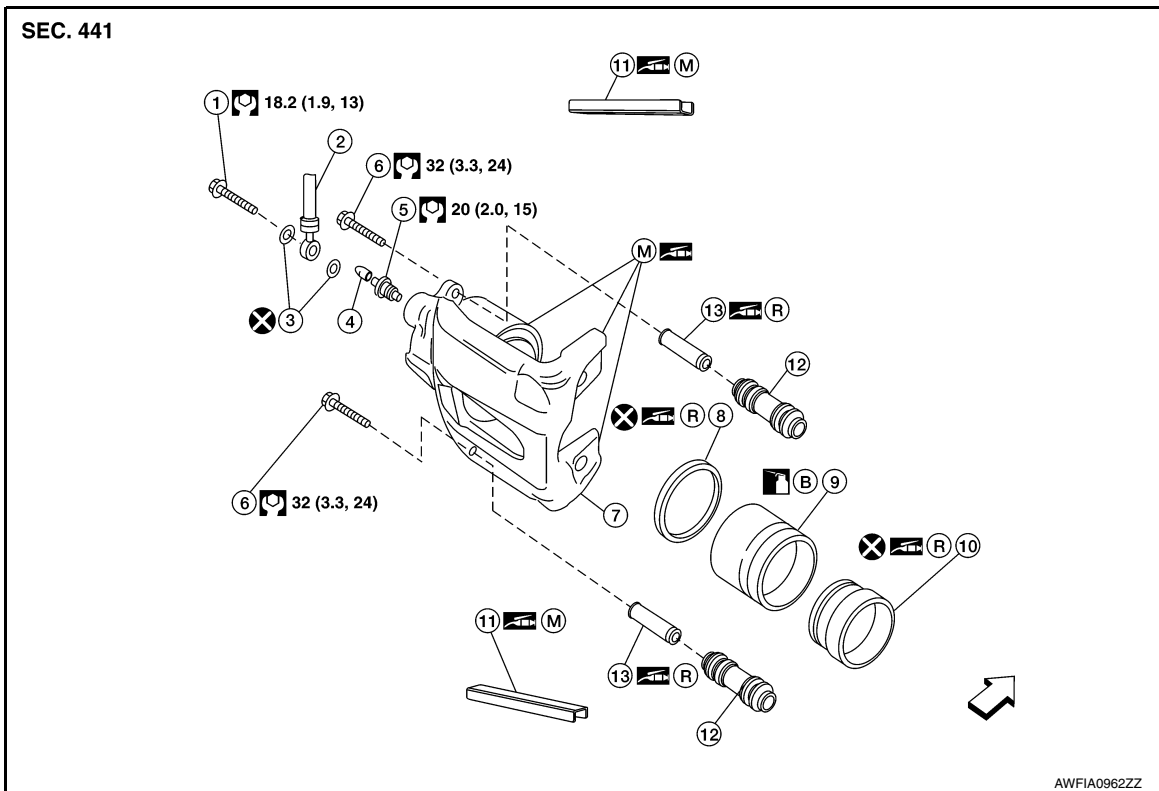

- | | | |
|--------------------|------------------|--------------------------|
| 1. Brake hose bolt | 2. Brake hose | 3. Copper sealing washer |
| 4. Cap | 5. Bleeder valve | 6. Sliding pin bolt |
| 7. Cylinder body | 8. Piston Seal | 9. Piston |
| 10. Piston boot | 11. Slipper | 12. Sliding sleeve boot |
| 13. Sliding sleeve | Brake fluid | 1: Molykote 7439 grease |
| 2: Rubber grease | Front | |

Removal and Installation of Brake Caliper and Disc Rotor

INFOID:000000009883560

WARNING:

REAR DISC BRAKE

< REMOVAL AND INSTALLATION >

Clean dust on caliper and brake pads with a vacuum dust collector to minimize the hazard of air borne particles or other materials.

CAUTION:

- While removing cylinder body, do not depress brake pedal because piston will pop out.
- It is not necessary to remove bolts on torque member and brake hose except for disassembly or replacement of caliper assembly. In this case, hang cylinder body with a wire so as not to stretch brake hose.
- Do not damage piston boot.
- If any shim is subject to serious corrosion, replace it with a new one.
- Always replace shim and shim cover as a set when replacing brake pads.
- Keep rotor free from brake fluid.
- Burnish the brake pads and disc rotor mutually contacting surfaces, after refinishing or replacing rotors, after replacing pads, or if a soft pedal occurs at very low mileage.

NOTE:

When removing components such as hoses, tubes/lines, etc., cap or plug openings to prevent fluid from spilling.

REMOVAL

1. Remove rear wheels and tires using power tool.
2. Fasten disc rotor using wheel nut.
3. Drain brake fluid as necessary. Refer to [BR-16. "Drain and Refill"](#).
4. Remove brake hose (A) from brake piping and cylinder body. Refer to [BR-22. "Removal and Installation of Rear Brake Piping and Brake Hose"](#).

CAUTION:

Do not reuse copper sealing washers.

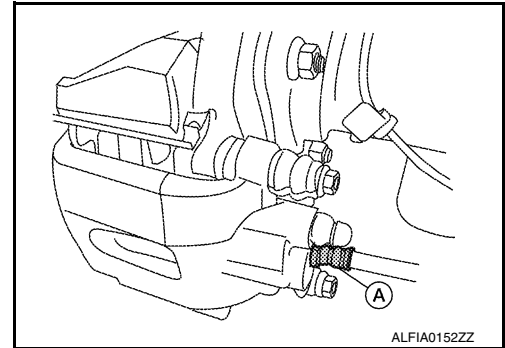

5. Remove sliding pin bolts (1) as shown, and remove cylinder body (2).

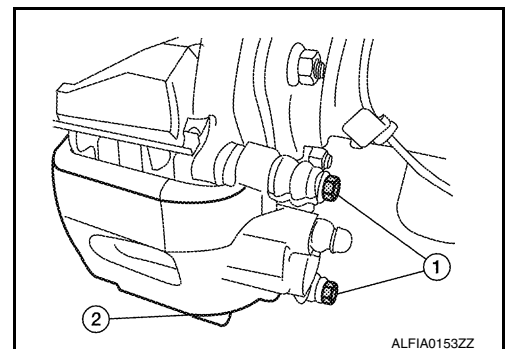

6. Apply matching marks to disc rotor and wheel hub assembly if the disc rotor is to be reused, then remove disc rotor.

CAUTION:

Put matching marks on wheel hub assembly and disc rotor if the disc rotor is to be reused.

INSTALLATION

1. If reusing the disc rotor, use the matching marks to align disc rotor on the wheel hub assembly, then install disc rotor using a wheel nut to hold it in place.

CAUTION:

Use matching marks on wheel hub assembly and disc rotor if the disc rotor is to be reused.

2. Apply Molykote 7439 grease to upper and lower slippers.

REAR DISC BRAKE

< REMOVAL AND INSTALLATION >

3. Install cylinder body (2) and tighten sliding pin bolts (1) to specification.

CAUTION:

Before installing cylinder body to the vehicle, wipe off mounting surface of cylinder body.

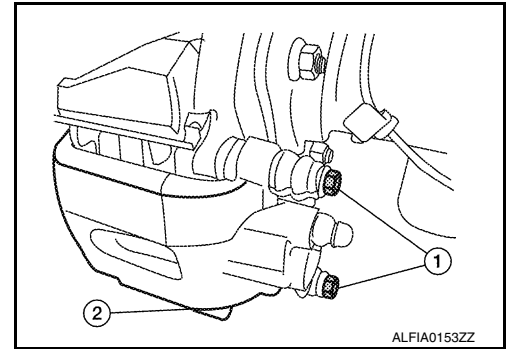

4. Install brake hose connection (A) and new copper sealing washer to cylinder body and tighten to specification.

CAUTION:

- Do not reuse copper sealing washer.
- Securely attach brake hose to protrusion on cylinder body.

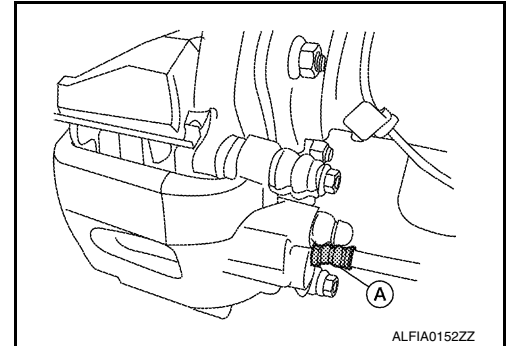

5. Install brake hose to brake piping. Refer to [BR-22, "Removal and Installation of Rear Brake Piping and Brake Hose"](#).
6. Refill with new brake fluid and bleed air. Refer to [BR-16, "Bleeding Brake System"](#).
7. Check rear disc brake for drag and correct as necessary.
8. Install rear wheels and tires. Refer to [WT-49, "Rotation"](#).

BRAKE MASTER CYLINDER

< UNIT DISASSEMBLY AND ASSEMBLY >

UNIT DISASSEMBLY AND ASSEMBLY

BRAKE MASTER CYLINDER

Disassembly and Assembly

INFOID:000000009883561

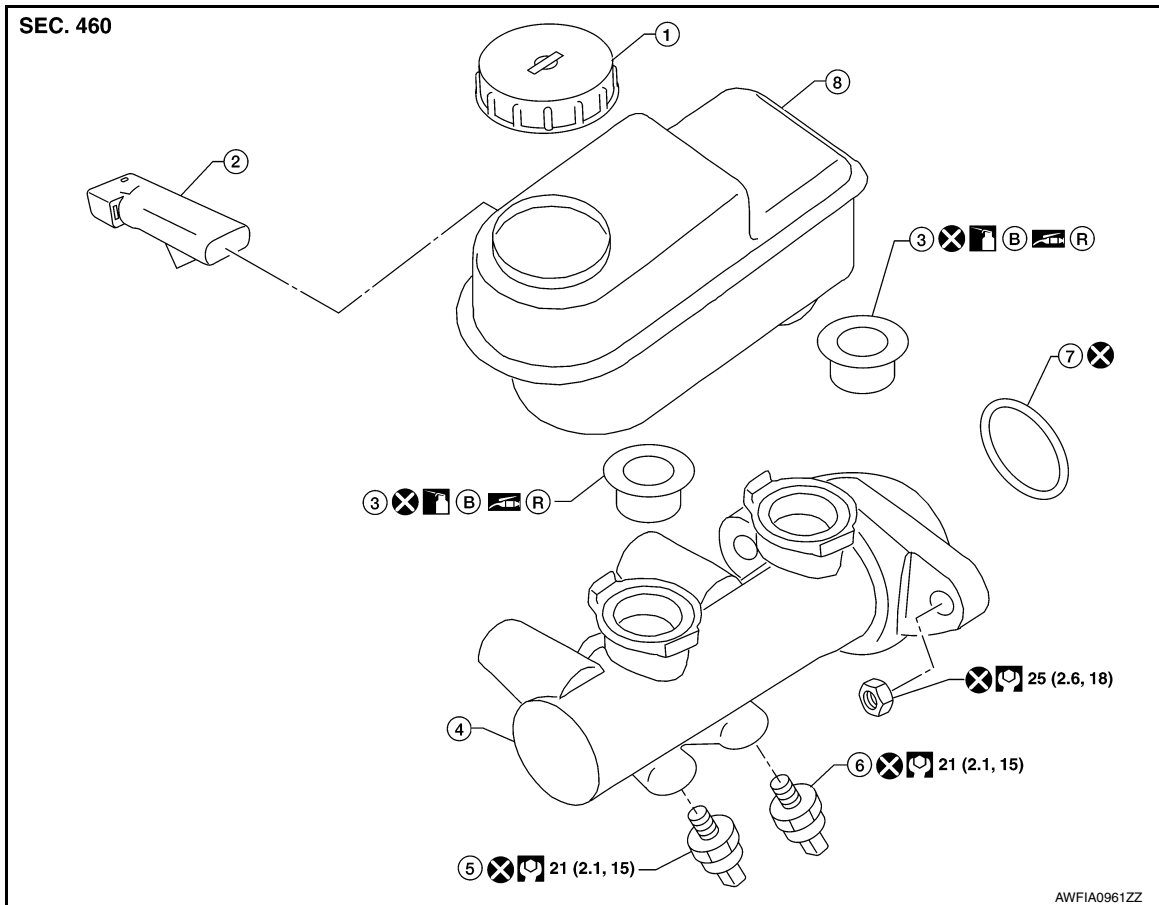

- | | | |
|-----------------------------|-------------------------|--------------------------|
| 1. Reservoir cap | 2. Fluid level sensor | 3. Grommet |
| 4. Master cylinder assembly | 5. Rear pressure sensor | 6. Front pressure sensor |
| 7. Seal | 8. Reservoir tank | B: Brake fluid |

R: Rubber grease

DISASSEMBLY

CAUTION:

- Master cylinder assembly cannot be disassembled.
- Do not drop parts. If a part is dropped, do not use it.

1. Pull the reservoir tank off the master cylinder assembly.
2. Remove the grommets from master cylinder assembly and discard the grommets.

CAUTION:

Discard the grommets, do not reuse.

3. Remove the fluid level sensor from the reservoir tank.
4. Remove the front and rear pressure sensors and discard.

CAUTION:

Discard the front and rear pressure sensors, do not reuse.

ASSEMBLY

CAUTION:

- Never use mineral oil such as kerosene, gasoline during the cleaning and assembly process.
- Do not drop parts. If a part is dropped, do not use it.

BRAKE MASTER CYLINDER

< UNIT DISASSEMBLY AND ASSEMBLY >

1. Apply brake fluid or rubber grease to the new grommets, then insert the new grommets into the master cylinder assembly.

CAUTION:

Do not reuse the grommets.

2. Install the reservoir tank onto the master cylinder assembly.
3. Install the fluid level sensor on the reservoir tank.
4. Install the new front and rear pressure sensors.

CAUTION:

Do not reuse the front and rear pressure sensors.

FRONT DISC BRAKE

< UNIT DISASSEMBLY AND ASSEMBLY >

FRONT DISC BRAKE

Disassembly and Assembly

INFOID:00000009883562

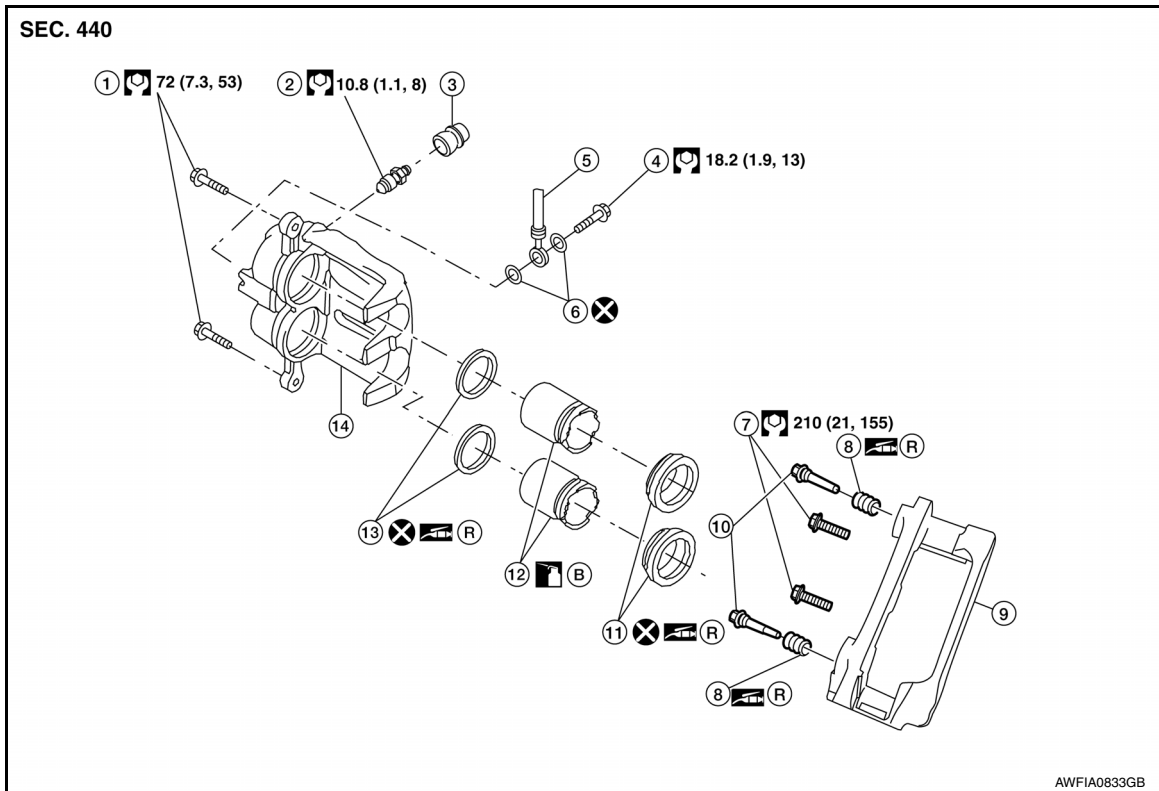

- | | | |
|-----------------------|---------------------|--------------------------|
| 1. Sliding pin bolt | 2. Bleed valve | 3. Cap |
| 4. Union bolt | 5. Brake hose | 6. Copper sealing washer |
| 7. Torque member bolt | 8. Sliding pin boot | 9. Torque member |
| 10. Washers | 11. Bushing | 12. Sliding pin |
| 13. Piston boot | 14. Piston | 15. Piston seal |
| 16. Cylinder body | B. Brake fluid | R. Rubber grease |

DISASSEMBLY

1. Remove sliding pin bolt, and then remove the pad, shim, shim cover, and pad retainer from the torque member.
2. Remove sliding pins and sliding pin boots from torque member.
3. Place a wooden block as shown, and blow air from union bolt hole to remove pistons and piston boots.

WARNING:

Do not get your fingers caught between piston and wooden block.

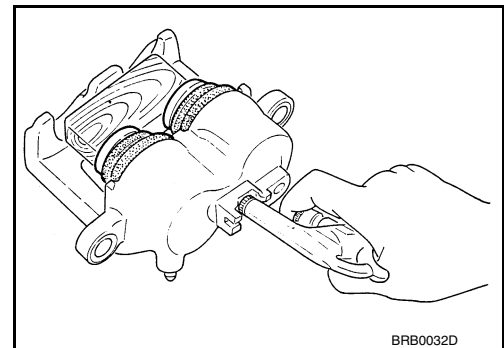

FRONT DISC BRAKE

< UNIT DISASSEMBLY AND ASSEMBLY >

4. Remove piston seals from cylinder body, using a suitable tool.

CAUTION:

- Be careful not to damage cylinder inner wall.
- Do not reuse piston seals.

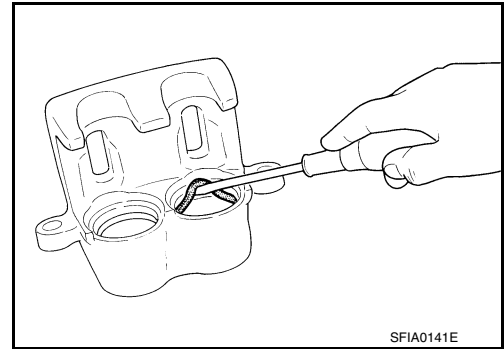

CALIPER INSPECTION

Cylinder Body

Check inside surface of cylinder for score, rust, wear, damage or foreign materials. If any of the above conditions are observed, replace cylinder body.

Minor damage from rust or foreign materials may be eliminated by polishing surface with a fine emery paper. Replace cylinder body if necessary.

CAUTION:

Use new brake fluid for cleaning. Do not use mineral oils such as gasoline or kerosene.

Torque Member

Check for wear, cracks, and damage. If damage or deformation is present, replace the affected part.

Piston

Check piston for score, rust, wear, damage or presence of foreign materials. Replace if any of the above conditions are observed.

CAUTION:

Piston sliding surface is plated, do not polish with emery paper even if rust or foreign materials are stuck to sliding surface.

Sliding Pins, and Sliding Pin Boots

Check sliding pin and sliding pin boot for wear, damage, and cracks. If damage or deformation is present, replace the affected part.

ASSEMBLY

1. Apply rubber grease to new piston seals and insert seals into grooves on cylinder body.

CAUTION:

Do not reuse piston seals.

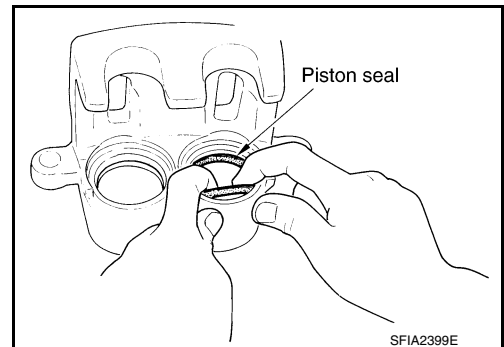

2. Apply rubber grease to piston boots. Cover the piston ends with piston boots, and then install cylinder side lip on piston boots securely into the grooves on cylinder body.

CAUTION:

Do not reuse piston boots.

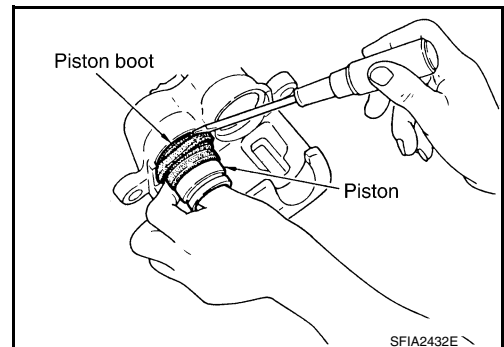

FRONT DISC BRAKE

< UNIT DISASSEMBLY AND ASSEMBLY >

3. Apply clean brake fluid to pistons (1), then install pistons into cylinder body and insert piston boot (2) side lip into groove of pistons as shown.

CAUTION:

Press pistons evenly and vary the pressing point to prevent cylinder inner wall from being rubbed.

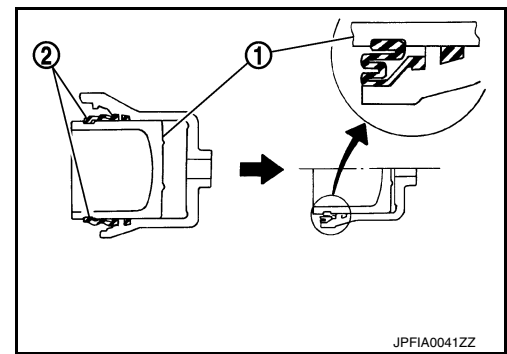

4. Install new sliding pins and sliding pin boots to torque member.
5. Install cylinder body. Tighten sliding pin bolts to the specified torque.

A

B

C

D

E

BR

G

H

I

J

K

L

M

N

O

P

REAR DISC BRAKE

< UNIT DISASSEMBLY AND ASSEMBLY >

REAR DISC BRAKE

Disassembly and Assembly

INFOID:000000009883563

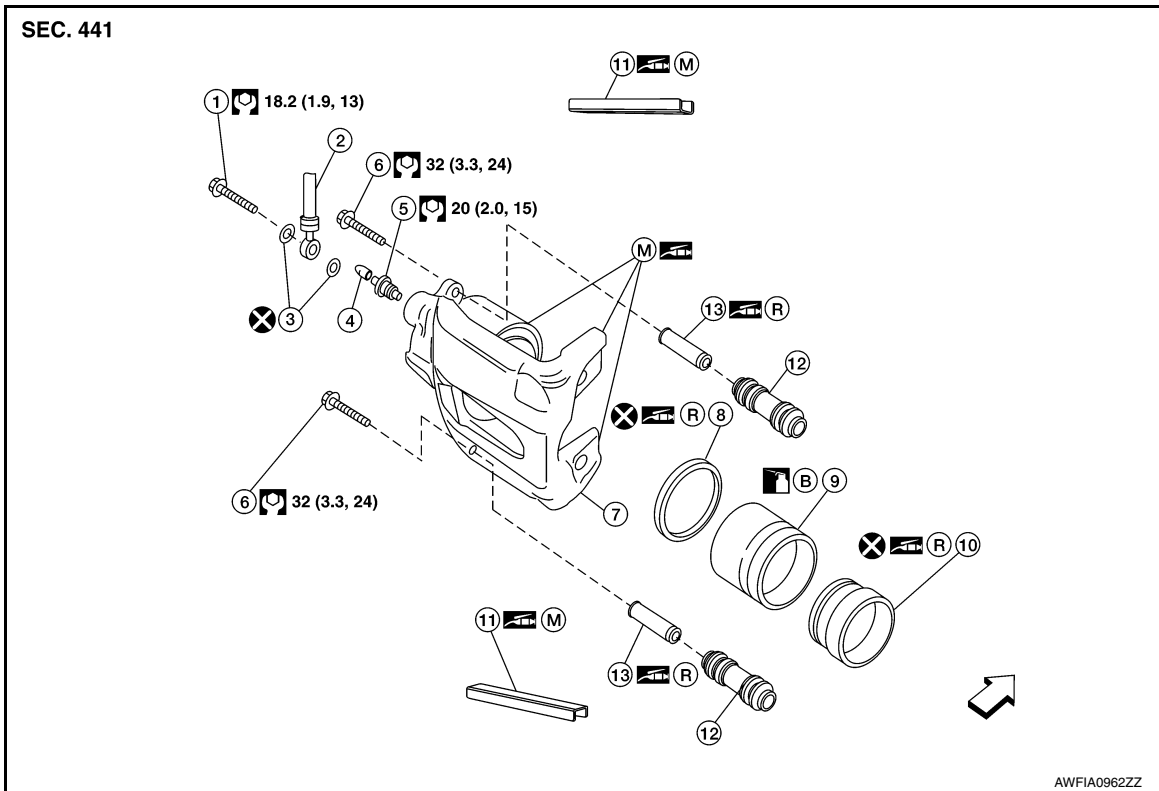

- | | | |
|--------------------|------------------|--------------------------|
| 1. Brake hose bolt | 2. Brake hose | 3. Copper sealing washer |
| 4. Cap | 5. Bleeder valve | 6. Sliding pin bolt |
| 7. Cylinder body | 8. Piston Seal | 9. Piston |
| 10. Piston boot | 11. Slipper | 12. Sliding sleeve boot |
| 13. Sliding sleeve | Brake fluid | 1: Molykote 7439 grease |
| 2: Rubber grease | Front | |

DISASSEMBLY

1. Remove pads from cylinder body.
2. Remove sliding sleeves and boots from cylinder body.
3. Place a wooden block as shown, and blow air into brake hose hole to remove piston and piston boot.

WARNING:

Do not get your fingers caught between piston and wooden block.

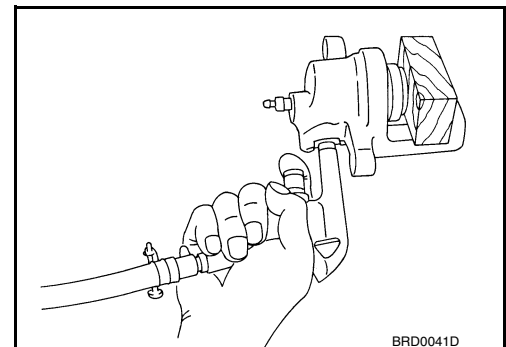

REAR DISC BRAKE

< UNIT DISASSEMBLY AND ASSEMBLY >

- Using a suitable tool, remove piston seal from cylinder body as shown.
CAUTION:
Be careful not to damage cylinder body inner wall.
- Remove the cap and bleed valve.

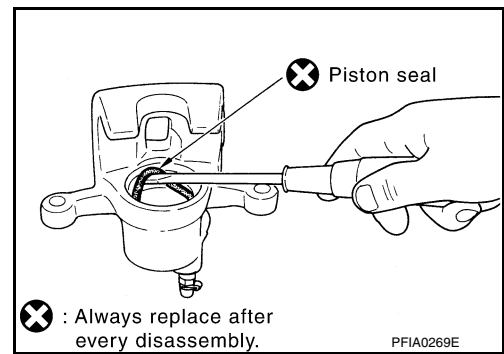

CALIPER INSPECTION

Cylinder Body

Check inside surface of cylinder body for score, rust wear, damage or foreign materials. If any of the above conditions are observed, replace cylinder body. Minor damage from rust or foreign materials may be eliminated by polishing surface with a fine emery paper. Replace cylinder body if necessary.

CAUTION:

- Use new brake fluid to clean. Do not use mineral oils such as gasoline or kerosene.

Torque Member

Check for wear, cracks, and damage. If damage or deformation is present, replace the affected part.

Piston

Check piston for score, rust, wear, damage or presence of foreign materials. Replace if any of the above conditions are observed.

CAUTION:

- Piston sliding surface is plated, do not polish with emery paper even if rust or foreign materials are stuck to sliding surface.

Sliding Pin Bolts and Sliding Pin Boots

Make sure there is no wear, damage, or cracks in sliding sleeve and sliding sleeve boots, and if there are, replace them.

ASSEMBLY

- Install bleed valve and cap.
- Apply rubber grease to new piston seal (1) and insert the new piston seal (1) in to groove on cylinder body.

CAUTION:

- Do not reuse piston seal.

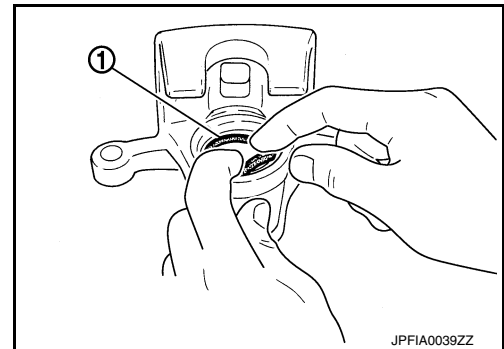

- Apply rubber grease to the new piston boot (2). Cover the piston end (1) with the piston boot (2), and then install the cylinder side lip on the piston boot (2) securely into the groove on the cylinder body.

CAUTION:

- Do not reuse piston boot.
- Press piston evenly and vary the pressing point to prevent cylinder body inner wall from being rubbed.

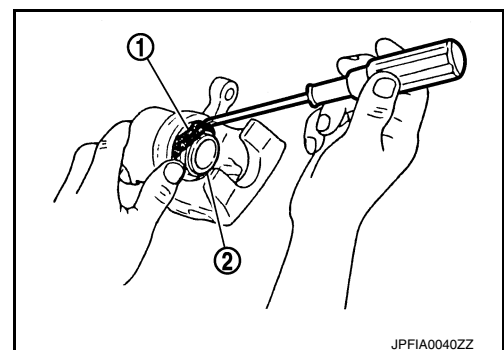

REAR DISC BRAKE

< UNIT DISASSEMBLY AND ASSEMBLY >

4. Install the piston (1) into the cylinder body and insert the piston boot (2) side lip into piston grooves as shown.

CAUTION:

Press piston evenly and vary the pressing point to prevent cylinder body inner wall from being rubbed.

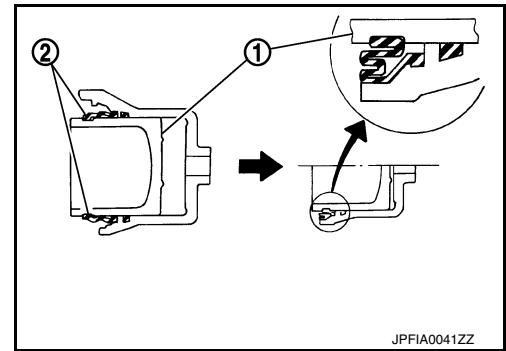

5. Apply rubber grease to sliding sleeves, then install sliding boots and sleeves to cylinder body.

SERVICE DATA AND SPECIFICATIONS (SDS)

< SERVICE DATA AND SPECIFICATIONS (SDS)

SERVICE DATA AND SPECIFICATIONS (SDS)

SERVICE DATA AND SPECIFICATIONS (SDS)

General Specification

INFOID:000000009883564

Unit: mm (in)

Front brake	Rotor outer diameter × thickness	350 × 30 (13.78 × 1.18)
	Pad Length × width × thickness	152 × 56.5 × 12.0 (5.98 × 2.22 × 0.47)
	Cylinder bore diameter (each)	2 × 50.8 (2.00)
Rear brake	Rotor outer diameter × thickness	320 × 14 (12.6 × 0.55)
	Pad Length × width × thickness	114 × 36.5 × 12.0 (4.49 × 1.44 × 0.47)
	Cylinder bore diameter	48 (1.89)
Control valve	Valve model	Electric brake force distribution
Brake booster	Booster model	9/10 inch active booster
Recommended brake fluid		Refer to MA-15. "FOR NORTH AMERICA : Fluids and Lubricants" (United States and Canada), MA-16. "FOR MEXICO : Fluids and Lubricants" (Mexico).

Brake Pedal

INFOID:000000009883565

STANDARD PEDAL

Unit: mm (in)

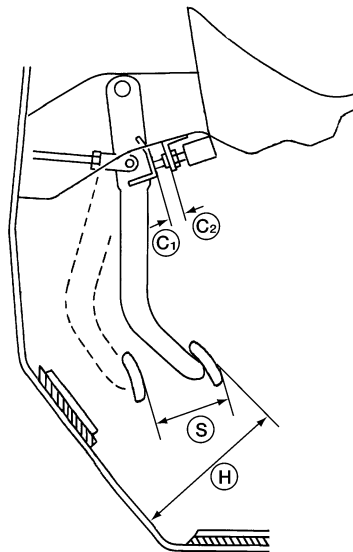

AWFIA0557ZZ

Free height (H)	182.3 +10/-0 (7.18 +0.39/-0)
Pedal full stroke (S)	152.3 (6.00)
Clearance between brake pedal bracket and the threaded end of stop lamp switch (C1) and ASCD cancel switch [if equipped] (C2)	0.74 – 1.96 (0.03 – 0.08)

ADJUSTABLE PEDAL

SERVICE DATA AND SPECIFICATIONS (SDS)

< SERVICE DATA AND SPECIFICATIONS (SDS)

Unit: mm (in)

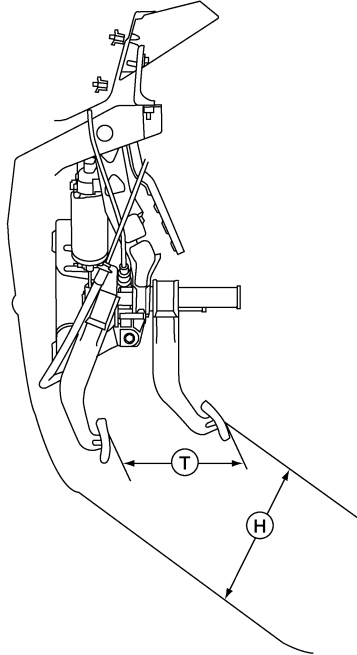

ALFIA0149ZZ

Pedal free height (H) with pedal in forward most position	182.3 +10/-0 (7.18 +0.39/-0)
Pedal full stroke (T)	153.3 (6.04)
Stop lamp switch and ASCD cancel switch threaded end to brake pedal bracket gap	0.74 - 1.96 (0.03 - 0.08)

CAUTION:

When equipped with adjustable pedal, the pedal must be in the forward most position (closest to the floor) for pedal height adjustment.

Brake Booster

INFOID:000000009883566

Unit: mm (in)

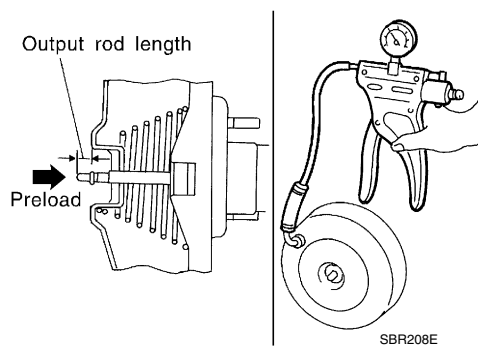

Output rod length [at -66.7 kPa (-500 mmHg, -19.69 inHg) vacuum]	15.6 - 15.9 (0.614 - 0.626)
--	-----------------------------

SERVICE DATA AND SPECIFICATIONS (SDS)

< SERVICE DATA AND SPECIFICATIONS (SDS)

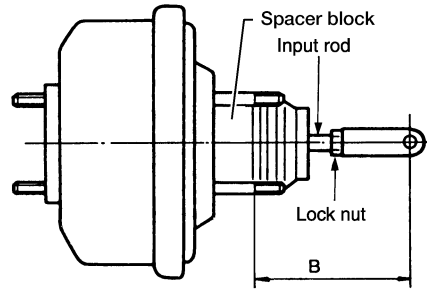

WFIA0382E

Input rod installation length (B)	145 - 152 (5.71 - 5.98)
-----------------------------------	-------------------------

Check Valve

INFOID:000000009883567

Vacuum leakage [at vacuum of - 66.7 kPa (- 500 mmHg, - 19.69 inHg)]	Within 1.3 kPa (10 mmHg, 0.39 inHg) of vacuum for 15 seconds
--	--

Front Disc Brake

INFOID:000000009883568

Unit: mm (in)

Brake pad	Standard thickness (new)	12.0 (0.47)
	Minimum thickness	1.0 (0.04)
Disc rotor	Standard thickness (new)	30.0 (1.18)
	Minimum thickness	28.5 (1.12)
	Maximum uneven wear (measured at 8 positions)	0.015 (0.001)
	Runout limit (with it attached to the vehicle)	0.03 (0.001)

Rear Disc Brake

INFOID:000000009883569

Unit: mm (in)

Brake pad	Standard thickness (new)	12.0 (0.47)
	Minimum thickness	1.0 (0.04)
Disc rotor	Standard thickness (new)	14.0 (0.55)
	Minimum Thickness	12.5 (0.47)
	Maximum uneven wear (measured at 8 positions)	0.015 (0.001)
	Runout limit (with it attached to the vehicle)	0.05 (0.002)