

A  
B  
C

# TM

## SECTION

# TRANSAXLE & TRANSMISSION

TM

## CONTENTS

<p><b>BASIC INSPECTION</b> ..... 6</p> <p><b>DIAGNOSIS AND REPAIR WORKFLOW</b> ..... 6</p> <p style="padding-left: 20px;">Work Flow .....6</p> <p style="padding-left: 20px;">Diagnostic Work Sheet .....7</p> <p><b>INSPECTION AND ADJUSTMENT</b> ..... 9</p> <p><b>ADDITIONAL SERVICE WHEN REPLACING TRANSMISSION ASSEMBLY</b> .....9</p> <p style="padding-left: 20px;">ADDITIONAL SERVICE WHEN REPLACING TRANSMISSION ASSEMBLY : Description .....9</p> <p style="padding-left: 20px;">ADDITIONAL SERVICE WHEN REPLACING TRANSMISSION ASSEMBLY : Special Repair Requirement .....9</p> <p><b>SYSTEM DESCRIPTION</b> .....10</p> <p><b>A/T CONTROL SYSTEM</b> .....10</p> <p style="padding-left: 20px;">Cross-Sectional View (2WD models) ..... 10</p> <p style="padding-left: 20px;">Cross-Sectional View (4WD models) ..... 11</p> <p style="padding-left: 20px;">Shift Mechanism ..... 11</p> <p style="padding-left: 20px;">TCM Function ..... 23</p> <p style="padding-left: 20px;">CAN Communication ..... 25</p> <p style="padding-left: 20px;">Input/Output Signal of TCM ..... 26</p> <p style="padding-left: 20px;">Line Pressure Control ..... 26</p> <p style="padding-left: 20px;">Shift Control ..... 28</p> <p style="padding-left: 20px;">Lock-up Control ..... 29</p> <p style="padding-left: 20px;">Engine Brake Control ..... 30</p> <p style="padding-left: 20px;">Control Valve ..... 30</p> <p style="padding-left: 20px;">Component Parts Location ..... 32</p> <p><b>A/T SHIFT LOCK SYSTEM</b> .....34</p> <p style="padding-left: 20px;">System Description ..... 34</p> <p style="padding-left: 20px;">Component Parts Location ..... 34</p> <p><b>ON BOARD DIAGNOSTIC (OBD) SYSTEM</b> .....36</p> <p style="padding-left: 20px;">Introduction ..... 36</p> <p style="padding-left: 20px;">OBD-II Function for A/T System ..... 36</p> <p style="padding-left: 20px;">One or Two Trip Detection Logic of OBD-II ..... 36</p> <p style="padding-left: 20px;">OBD-II Diagnostic Trouble Code (DTC) ..... 36</p> <p style="padding-left: 20px;">Malfunction Indicator Lamp (MIL) ..... 37</p>	<p><b>DIAGNOSIS SYSTEM (TCM)</b> .....38</p> <p style="padding-left: 20px;">CONSULT Function (TRANSMISSION) .....38</p> <p style="padding-left: 20px;">Diagnosis Procedure without CONSULT (Floor Shift Models) .....43</p> <p style="padding-left: 20px;">Diagnosis Procedure without CONSULT (Column Shift Models) .....45</p> <p><b>DTC/CIRCUIT DIAGNOSIS</b> .....47</p> <p><b>U0100 LOST COMMUNICATION (ECM A)</b> .....47</p> <p style="padding-left: 20px;">Description .....47</p> <p style="padding-left: 20px;">On Board Diagnosis Logic .....47</p> <p style="padding-left: 20px;">Possible Cause .....47</p> <p style="padding-left: 20px;">DTC Confirmation Procedure .....47</p> <p style="padding-left: 20px;">Diagnosis Procedure .....47</p> <p><b>U1000 CAN COMM CIRCUIT</b> .....48</p> <p style="padding-left: 20px;">Description .....48</p> <p style="padding-left: 20px;">On Board Diagnosis Logic .....48</p> <p style="padding-left: 20px;">Possible Cause .....48</p> <p style="padding-left: 20px;">DTC Confirmation Procedure .....48</p> <p style="padding-left: 20px;">Diagnosis Procedure .....48</p> <p><b>P0615 STARTER RELAY</b> .....49</p> <p style="padding-left: 20px;">Description .....49</p> <p style="padding-left: 20px;">CONSULT Reference Value in Data Monitor Mode .....49</p> <p style="padding-left: 20px;">On Board Diagnosis Logic .....49</p> <p style="padding-left: 20px;">Possible Cause .....49</p> <p style="padding-left: 20px;">DTC Confirmation Procedure .....49</p> <p style="padding-left: 20px;">Diagnosis Procedure .....49</p> <p><b>P0700 TRANSMISSION CONTROL</b> .....52</p> <p style="padding-left: 20px;">Description .....52</p> <p style="padding-left: 20px;">On Board Diagnosis Logic .....52</p> <p style="padding-left: 20px;">Possible Cause .....52</p> <p style="padding-left: 20px;">DTC Confirmation Procedure .....52</p> <p style="padding-left: 20px;">Diagnosis Procedure .....52</p> <p><b>P0705 TRANSMISSION RANGE SWITCH A</b> ...53</p> <p style="padding-left: 20px;">Description .....53</p>
---	--

E  
F  
G  
H  
I  
J  
K  
L  
M  
N  
O

CONSULT Reference Value in Data Monitor	Diagnosis Procedure .....	70
Mode .....	<b>P0735 5GR INCORRECT RATIO .....</b>	<b>71</b>
On Board Diagnosis Logic .....	Description .....	71
Possible Cause .....	On Board Diagnosis Logic .....	71
DTC Confirmation Procedure .....	Possible Cause .....	71
Diagnosis Procedure .....	DTC Confirmation Procedure .....	71
<b>P0717 INPUT SPEED SENSOR A .....</b>	Diagnosis Procedure .....	72
Description .....	<b>P0740 TORQUE CONVERTER .....</b>	<b>73</b>
CONSULT Reference Value in Data Monitor	Description .....	73
Mode .....	CONSULT Reference Value in Data Monitor	
On Board Diagnosis Logic .....	Mode .....	73
Possible Cause .....	On Board Diagnosis Logic .....	73
DTC Confirmation Procedure .....	Possible Cause .....	73
Diagnosis Procedure .....	DTC Confirmation Procedure .....	73
<b>P0720 OUTPUT SPEED SENSOR .....</b>	Diagnosis Procedure .....	73
Description .....	<b>P0744 TORQUE CONVERTER .....</b>	<b>75</b>
CONSULT Reference Value in Data Monitor	Description .....	75
Mode .....	CONSULT Reference Value in Data Monitor	
On Board Diagnosis Logic .....	Mode .....	75
Possible Cause .....	On Board Diagnosis Logic .....	75
DTC Confirmation Procedure .....	Possible Cause .....	75
Diagnosis Procedure .....	DTC Confirmation Procedure .....	75
<b>P0725 ENGINE SPEED .....</b>	Diagnosis Procedure .....	75
Description .....	<b>P0745 PRESSURE CONTROL SOLENOID A..</b>	<b>77</b>
CONSULT Reference Value in Data Monitor	Description .....	77
Mode .....	CONSULT Reference Value in Data Monitor	
On Board Diagnosis Logic .....	Mode .....	77
Possible Cause .....	On Board Diagnosis Logic .....	77
DTC Confirmation Procedure .....	Possible Cause .....	77
Diagnosis Procedure .....	DTC Confirmation Procedure .....	77
<b>P0731 1GR INCORRECT RATIO .....</b>	Diagnosis Procedure .....	77
Description .....	<b>P1705 TP SENSOR .....</b>	<b>79</b>
On Board Diagnosis Logic .....	Description .....	79
Possible Cause .....	CONSULT Reference Value in Data Monitor	
DTC Confirmation Procedure .....	Mode .....	79
Diagnosis Procedure .....	On Board Diagnosis Logic .....	79
<b>P0732 2GR INCORRECT RATIO .....</b>	Possible Cause .....	79
Description .....	DTC Confirmation Procedure .....	79
On Board Diagnosis Logic .....	Diagnosis Procedure .....	79
Possible Cause .....	<b>P1710 TRANSMISSION FLUID TEMPERA-</b>	
DTC Confirmation Procedure .....	<b>TURE SENSOR .....</b>	<b>81</b>
Diagnosis Procedure .....	Description .....	81
<b>P0733 3GR INCORRECT RATIO .....</b>	CONSULT Reference Value in Data Monitor	
Description .....	Mode .....	81
On Board Diagnosis Logic .....	On Board Diagnosis Logic .....	81
Possible Cause .....	Possible Cause .....	81
DTC Confirmation Procedure .....	DTC Confirmation Procedure .....	81
Diagnosis Procedure .....	Diagnosis Procedure .....	82
<b>P0734 4GR INCORRECT RATIO .....</b>	Component Inspection .....	83
Description .....	<b>P1721 VEHICLE SPEED SIGNAL .....</b>	<b>84</b>
On Board Diagnosis Logic .....	Description .....	84
Possible Cause .....	CONSULT Reference Value in Data Monitor	
DTC Confirmation Procedure .....	Mode .....	84

On Board Diagnosis Logic .....	84	Description .....	98	
Possible Cause .....	84	CONSULT Reference Value in Data Monitor		A
DTC Confirmation Procedure .....	84	Mode .....	98	
Diagnosis Procedure .....	84	On Board Diagnosis Logic .....	98	
<b>P1730 INTERLOCK .....</b>	<b>86</b>	Possible Cause .....	98	B
Description .....	86	DTC Confirmation Procedure .....	98	
On Board Diagnosis Logic .....	86	Diagnosis Procedure .....	98	
Possible Cause .....	86	<b>P1774 LOW COAST BRAKE SOLENOID .....</b>	<b>100</b>	C
DTC Confirmation Procedure .....	86	Description .....	100	
Judgment of Interlock .....	86	CONSULT Reference Value in Data Monitor		
Diagnosis Procedure .....	86	Mode .....	100	TM
<b>P1731 1ST ENGINE BRAKING .....</b>	<b>88</b>	On Board Diagnosis Logic .....	100	
Description .....	88	Possible Cause .....	100	
CONSULT Reference Value in Data Monitor		DTC Confirmation Procedure .....	100	E
Mode .....	88	Diagnosis Procedure .....	101	
On Board Diagnosis Logic .....	88	<b>P1815 M-MODE SWITCH .....</b>	<b>102</b>	F
Possible Cause .....	88	Description .....	102	
DTC Confirmation Procedure .....	88	CONSULT Reference Value in Data Monitor		
Diagnosis Procedure .....	88	Mode .....	102	G
<b>P1752 INPUT CLUTCH SOLENOID .....</b>	<b>90</b>	On Board Diagnosis Logic .....	102	
Description .....	90	Possible Cause .....	102	
CONSULT Reference Value in Data Monitor		DTC Confirmation Procedure .....	102	H
Mode .....	90	Diagnosis Procedure .....	102	
On Board Diagnosis Logic .....	90	Component Inspection .....	103	I
Possible Cause .....	90	Position Indicator Lamp .....	103	
DTC Confirmation Procedure .....	90	<b>MAIN POWER SUPPLY AND GROUND CIR-</b>		J
Diagnosis Procedure .....	90	<b>CUIT .....</b>	<b>105</b>	
<b>P1757 FRONT BRAKE SOLENOID .....</b>	<b>92</b>	Diagnosis Procedure .....	105	
Description .....	92	Component Inspection .....	108	
CONSULT Reference Value in Data Monitor		<b>CLOSED THROTTLE POSITION AND WIDE</b>		K
Mode .....	92	<b>OPEN THROTTLE POSITION CIRCUIT .....</b>	<b>109</b>	
On Board Diagnosis Logic .....	92	CONSULT Reference Value in Data Monitor		
Possible Cause .....	92	Mode .....	109	
DTC Confirmation Procedure .....	92	Diagnosis Procedure .....	109	L
Diagnosis Procedure .....	92	<b>BRAKE SIGNAL CIRCUIT .....</b>	<b>110</b>	
<b>P1762 DIRECT CLUTCH SOLENOID .....</b>	<b>94</b>	CONSULT Reference Value in Data Monitor		M
Description .....	94	Mode .....	110	
CONSULT Reference Value in Data Monitor		Diagnosis Procedure .....	110	
Mode .....	94	<b>TOW MODE SWITCH .....</b>	<b>111</b>	N
On Board Diagnosis Logic .....	94	Description .....	111	
Possible Cause .....	94	Diagnosis Procedure .....	111	
DTC Confirmation Procedure .....	94	<b>A/T SHIFT LOCK SYSTEM .....</b>	<b>112</b>	O
Diagnosis Procedure .....	94	Description .....	112	
<b>P1767 HIGH AND LOW REVERSE CLUTCH</b>		Terminals And Reference Values .....	112	
<b>SOLENOID .....</b>	<b>96</b>	Component Inspections (Floor Shift Models) .....	112	
Description .....	96	Component Inspections (Column Shift Models) .....	114	P
CONSULT Reference Value in Data Monitor		<b>1ST POSITION SWITCH .....</b>	<b>116</b>	
Mode .....	96	CONSULT Reference Value in Data Monitor		
On Board Diagnosis Logic .....	96	Mode .....	116	
Possible Cause .....	96	Diagnosis Procedure .....	116	
DTC Confirmation Procedure .....	96	<b>4TH POSITION SWITCH .....</b>	<b>118</b>	
Diagnosis Procedure .....	96			
<b>P1772 LOW COAST BRAKE SOLENOID .....</b>	<b>98</b>			

CONSULT Reference Value in Data Monitor Mode .....	118	Check Before Engine Is Started .....	183
Diagnosis Procedure .....	118	Check At Idle .....	183
<b>ECU DIAGNOSIS INFORMATION .....</b>	<b>120</b>	Cruise Test - Part 1 .....	184
<b>TCM .....</b>	<b>120</b>	Cruise Test - Part 2 .....	186
Reference Value .....	120	Cruise Test - Part 3 .....	186
Fail-Safe .....	122	<b>REMOVAL AND INSTALLATION .....</b>	<b>188</b>
DTC Inspection Priority Chart .....	123	<b>SHIFT CONTROL SYSTEM .....</b>	<b>188</b>
DTC No. Index .....	123	Exploded View .....	188
<b>WIRING DIAGRAM .....</b>	<b>125</b>	A/T Shift Selector Removal and Installation .....	189
<b>A/T CONTROL SYSTEM .....</b>	<b>125</b>	Inspection and Adjustment .....	190
Wiring Diagram .....	125	<b>CONTROL CABLE .....</b>	<b>191</b>
<b>A/T SHIFT LOCK SYSTEM .....</b>	<b>136</b>	Exploded View .....	191
Wiring Diagram - Column Shift .....	136	Removal and Installation .....	191
Wiring Diagram - Floor Shift .....	139	<b>KEY INTERLOCK CABLE .....</b>	<b>192</b>
<b>SYMPTOM DIAGNOSIS .....</b>	<b>143</b>	Component .....	192
<b>SYSTEM SYMPTOM .....</b>	<b>143</b>	Removal and Installation .....	192
Symptom Table .....	143	<b>AIR BREATHER HOSE .....</b>	<b>195</b>
<b>PRECAUTION .....</b>	<b>167</b>	<b>2WD .....</b>	<b>195</b>
<b>PRECAUTIONS .....</b>	<b>167</b>	2WD : Removal and Installation .....	195
Precaution for Supplemental Restraint System (SRS) "AIR BAG" and "SEAT BELT PRE-TENSIONER" .....	167	<b>4WD .....</b>	<b>195</b>
Precaution for Work .....	167	4WD : Removal and Installation .....	195
Precautions for On Board Diagnosis (OBD) System of A/T and Engine .....	167	<b>OIL PAN .....</b>	<b>199</b>
Precautions .....	168	Removal and Installation .....	199
Service Notice or Precautions .....	169	<b>CONTROL VALVE WITH TCM .....</b>	<b>201</b>
<b>PREPARATION .....</b>	<b>170</b>	Control Valve with TCM .....	201
<b>PREPARATION .....</b>	<b>170</b>	<b>REAR OIL SEAL .....</b>	<b>209</b>
Special Service Tool .....	170	Removal and Installation .....	209
Commercial Service Tool .....	171	<b>FLUID COOLER SYSTEM .....</b>	<b>210</b>
<b>PERIODIC MAINTENANCE .....</b>	<b>172</b>	Exploded View .....	210
<b>A/T FLUID .....</b>	<b>172</b>	Removal and Installation .....	210
Checking the A/T Fluid (ATF) .....	172	<b>UNIT REMOVAL AND INSTALLATION ...</b>	<b>211</b>
Changing the A/T Fluid (ATF) .....	174	<b>TRANSMISSION ASSEMBLY .....</b>	<b>211</b>
<b>A/T FLUID COOLER .....</b>	<b>176</b>	Removal and Installation (2WD) .....	211
A/T Fluid Cooler Cleaning .....	176	Removal and Installation (4WD) .....	213
Inspection .....	178	<b>UNIT DISASSEMBLY AND ASSEMBLY ..</b>	<b>217</b>
<b>STALL TEST .....</b>	<b>179</b>	<b>OVERHAUL .....</b>	<b>217</b>
Inspection and Judgment .....	179	Component .....	217
<b>LINE PRESSURE TEST .....</b>	<b>181</b>	Oil Channel .....	224
Inspection and Judgment .....	181	Location of Adjusting Shims, Needle Bearings, Thrust Washers and Snap Rings .....	226
<b>ROAD TEST .....</b>	<b>183</b>	<b>DISASSEMBLY .....</b>	<b>229</b>
Description .....	183	Disassembly .....	229
		<b>REPAIR FOR COMPONENT PARTS .....</b>	<b>247</b>
		Oil Pump .....	247
		Front Sun Gear, 3rd One-Way Clutch .....	249
		Front Carrier, Input Clutch, Rear Internal Gear ....	251

Mid Sun Gear, Rear Sun Gear, High and Low Reverse Clutch Hub .....	256
High and Low Reverse Clutch .....	261
Direct Clutch .....	263

<b>ASSEMBLY .....</b>	<b>266</b>
Assembly (1) .....	266
Adjustment .....	279
Assembly (2) .....	281

<b>SERVICE DATA AND SPECIFICATIONS (SDS) .....</b>	<b>288</b>
--	------------

<b>SERVICE DATA AND SPECIFICATIONS (SDS) .....</b>	<b>288</b>
General Specification .....	288
Vehicle Speed at Which Gear Shifting Occurs .....	288
Vehicle Speed at Which Lock-up Occurs/Releases .....	289
Stall Speed .....	289
Line Pressure .....	289
Input Speed Sensor .....	289
Output Speed Sensor .....	289
Reverse Brake .....	289
Total End Play .....	290
Torque Converter .....	290

A  
B  
C  
TM

E  
F  
G  
H  
I  
J  
K  
L  
M  
N  
O  
P

# DIAGNOSIS AND REPAIR WORKFLOW

< BASIC INSPECTION >

## BASIC INSPECTION

### DIAGNOSIS AND REPAIR WORKFLOW

#### Work Flow

INFOID:000000009885679

#### INTRODUCTION

The TCM receives a signal from the output speed sensor, accelerator pedal position sensor (throttle position sensor) or transmission range switch. Then provides shift control or lock-up control via A/T solenoid valves.

The TCM also communicates with the ECM by means of a signal sent from sensing elements used with the OBD-related parts of the A/T system for malfunction-diagnostic purposes. The TCM is capable of diagnosing malfunctioning parts while the ECM can store malfunctions in its memory.

Input and output signals must always be correct and stable in the operation of the A/T system. The A/T system must be in good operating condition and be free of valve seizure, solenoid valve malfunction, etc.

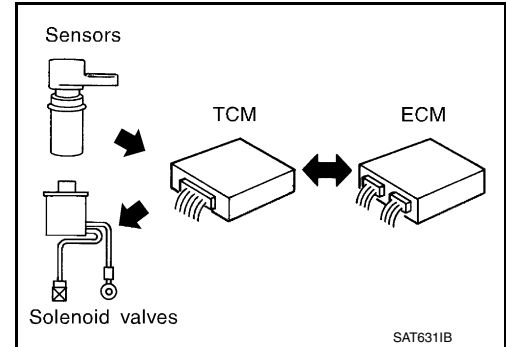

It is much more difficult to diagnose an error that occurs intermittently rather than continuously. Most intermittent errors are caused by poor electric connections or improper wiring. In this case, careful checking of suspected circuits may help prevent the replacement of good parts.

A visual check only may not find the cause of the errors. A road test with CONSULT (or GST) or a circuit tester connected should be performed. Follow the "DETAILED FLOW".

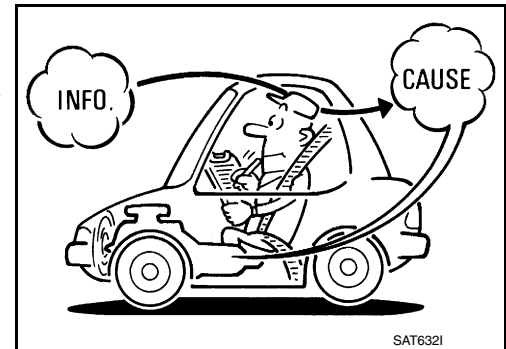

Before undertaking actual checks, take a few minutes to talk with a customer who approaches with a driveability complaint. The customer can supply good information about such errors, especially intermittent ones. Find out what symptoms are present and under what conditions they occur. A "Diagnostic work sheet" as shown on the example (Refer to [TM-7](#)) should be used.

Start your diagnosis by looking for "conventional" errors first. This will help troubleshoot driveability errors on an electronically controlled engine vehicle.

Also check related Service bulletins.

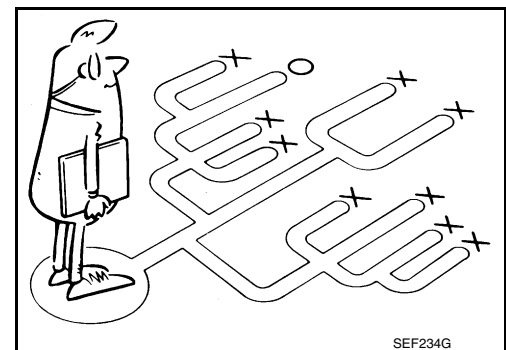

#### DETAILED FLOW

##### 1. COLLECT THE INFORMATION FROM THE CUSTOMER

Get the detailed information from the customer about the symptom (the condition and the environment when the incident/malfunction occurred) using diagnosis worksheet. Refer to [TM-7, "Diagnostic Work Sheet"](#).

>> GO TO 2.

##### 2. CHECK SYMPTOM 1

Check the following items based on the information obtained from the customer.

- Fail-safe. Refer to [TM-122, "Fail-Safe"](#).
- A/T fluid inspection. Refer to [TM-172, "Checking the A/T Fluid \(ATF\)"](#).
- Stall test. Refer to [TM-179, "Inspection and Judgment"](#).
- Line pressure test. Refer to [TM-181, "Inspection and Judgment"](#).

# DIAGNOSIS AND REPAIR WORKFLOW

## < BASIC INSPECTION >

>> GO TO 3.

### 3. CHECK DTC

1. Check DTC.
2. Perform the following procedure if DTC is detected.
  - Record DTC.
  - Erase DTC. Refer to [TM-36. "OBD-II Diagnostic Trouble Code \(DTC\)"](#).

Is any DTC detected?

YES >> GO TO 4.

NO >> GO TO 6.

### 4. PERFORM DIAGNOSTIC PROCEDURE

Perform "Diagnosis Procedure" for the displayed DTC.

>> GO TO 5.

### 5. PERFORM DTC CONFIRMATION PROCEDURE

Perform "DTC CONFIRMATION PROCEDURE".

Is DTC detected?

YES >> GO TO 4.

NO >> GO TO 6.

### 6. CHECK SYMPTOM 2

Try to confirm the symptom described by the customer.

Is any malfunction present?

YES >> GO TO 7.

NO >> INSPECTION END

### 7. ROAD TEST

Perform "ROAD TEST". Refer to [TM-183. "Description"](#).

>> GO TO 8.

### 8. CHECK SYMPTOM 3

Try to confirm the symptom described by the customer.

Is any malfunction present?

YES >> GO TO 2.

NO >> INSPECTION END

## Diagnostic Work Sheet

INFOID:000000009885680

### INFORMATION FROM CUSTOMER

#### KEY POINTS

- **WHAT**..... Vehicle and A/T model
- **WHEN**..... Date, Frequencies
- **WHERE**..... Road conditions
- **HOW**..... Operating conditions, Symptoms

Customer name MR/MS	Model and Year	VIN
Trans. Model	Engine	Mileage
Malfunction Date	Manuf. Date	In Service Date
Frequency	<input type="checkbox"/> Continuous <input type="checkbox"/> Intermittent ( times a day)	

# DIAGNOSIS AND REPAIR WORKFLOW

## < BASIC INSPECTION >

Symptoms	<input type="checkbox"/> Vehicle does not move. ( <input type="checkbox"/> Any position <input type="checkbox"/> Particular position)	
	<input type="checkbox"/> No up-shift ( <input type="checkbox"/> 1st → 2nd <input type="checkbox"/> 2nd → 3rd <input type="checkbox"/> 3rd → 4th <input type="checkbox"/> 4th → 5th)	
	<input type="checkbox"/> No down-shift ( <input type="checkbox"/> 5th → 4th <input type="checkbox"/> 4th → 3rd <input type="checkbox"/> 3rd → 2nd <input type="checkbox"/> 2nd → 1st)	
	<input type="checkbox"/> Lock-up malfunction	
	<input type="checkbox"/> Shift point too high or too low.	
	<input type="checkbox"/> Shift shock or slip ( <input type="checkbox"/> N → D <input type="checkbox"/> N → R <input type="checkbox"/> Lock-up <input type="checkbox"/> Any drive position)	
	<input type="checkbox"/> Noise or vibration	
	<input type="checkbox"/> No kick down	
	<input type="checkbox"/> No pattern select	
<input type="checkbox"/> Others ( )		
A/T CHECK indicator lamp	<input type="checkbox"/> Continuously lit	<input type="checkbox"/> Not lit
Malfunction indicator lamp (MIL)	<input type="checkbox"/> Continuously lit	<input type="checkbox"/> Not lit

## DIAGNOSTIC WORK SHEET

1	<input type="checkbox"/> Read the item on cautions concerning fail-safe and understand the customer's complaint.		<a href="#">TM-122</a>	
2	<input type="checkbox"/> A/T fluid inspection, stall test and line pressure test		<a href="#">TM-172</a>	
	<input type="checkbox"/> A/T fluid inspection	<input type="checkbox"/> Leak (Repair leak location.) <input type="checkbox"/> State <input type="checkbox"/> Amount		
	<input type="checkbox"/> Stall test	<input type="checkbox"/> Torque converter one-way clutch <input type="checkbox"/> Front brake <input type="checkbox"/> High and low reverse clutch <input type="checkbox"/> Low coast brake <input type="checkbox"/> Forward brake <input type="checkbox"/> Reverse brake <input type="checkbox"/> Forward one-way clutch	<a href="#">TM-179</a>	
	<input type="checkbox"/> Line pressure test - Suspected part:	<input type="checkbox"/> 1st one-way clutch <input type="checkbox"/> 3rd one-way clutch <input type="checkbox"/> Engine <input type="checkbox"/> Line pressure low <input type="checkbox"/> Except for input clutch and direct clutch, clutches and brakes OK	<a href="#">TM-181</a>	
3	<input type="checkbox"/> Perform self-diagnosis. — Check detected items to repair or replace malfunctioning part.		<a href="#">TM-38</a>	
4	<input type="checkbox"/> Perform road test.		<a href="#">TM-183</a>	
	5-1	<input type="checkbox"/> Check before engine is started		
	5-2	<input type="checkbox"/> Check at idle	<a href="#">TM-183</a>	
	5-3	Cruise test	<input type="checkbox"/> Part 1	<a href="#">TM-184</a>
			<input type="checkbox"/> Part 2	<a href="#">TM-186</a>
			<input type="checkbox"/> Part 3	<a href="#">TM-186</a>
<input type="checkbox"/> Check malfunction phenomena to repair or replace malfunctioning part after completing all road test. Refer to <a href="#">TM-143</a> .				
5	<input type="checkbox"/> Drive vehicle to check that the malfunction phenomenon has been resolved.			
6	<input type="checkbox"/> Erase the results of the self-diagnosis from the TCM and the ECM.		<a href="#">TM-36</a>	



# INSPECTION AND ADJUSTMENT

< BASIC INSPECTION >

## INSPECTION AND ADJUSTMENT

### ADDITIONAL SERVICE WHEN REPLACING TRANSMISSION ASSEMBLY

### ADDITIONAL SERVICE WHEN REPLACING TRANSMISSION ASSEMBLY : Description

INFOID:000000010152498

When replacing transmission assembly, save current TCM data using CONSULT before replacement.

### ADDITIONAL SERVICE WHEN REPLACING TRANSMISSION ASSEMBLY : Special Repair Requirement

INFOID:000000010152499

#### 1. SAVING TCM DATA

##### With CONSULT

Save the TCM data according to the CONSULT display.

##### NOTE:

Even when TCM data is not saved in CONSULT, GO TO 2.

>> GO TO 2.

#### 2. REPLACE TRANSMISSION ASSEMBLY

Replace the transmission assembly. Refer to [TM-211, "Removal and Installation \(2WD\)"](#) or [TM-213, "Removal and Installation \(4WD\)"](#).

>> GO TO 3.

#### 3. PERFORM TCM PROGRAMMING

##### With CONSULT

1. During programming, maintain the following conditions:

Ignition switch : ON  
Selector lever : P  
Engine speed : 0 rpm

2. Perform programming according to the CONSULT display.

>> WORK END

# A/T CONTROL SYSTEM

< SYSTEM DESCRIPTION >

## SYSTEM DESCRIPTION

### A/T CONTROL SYSTEM

Cross-Sectional View (2WD models)

INFOID:000000009885681

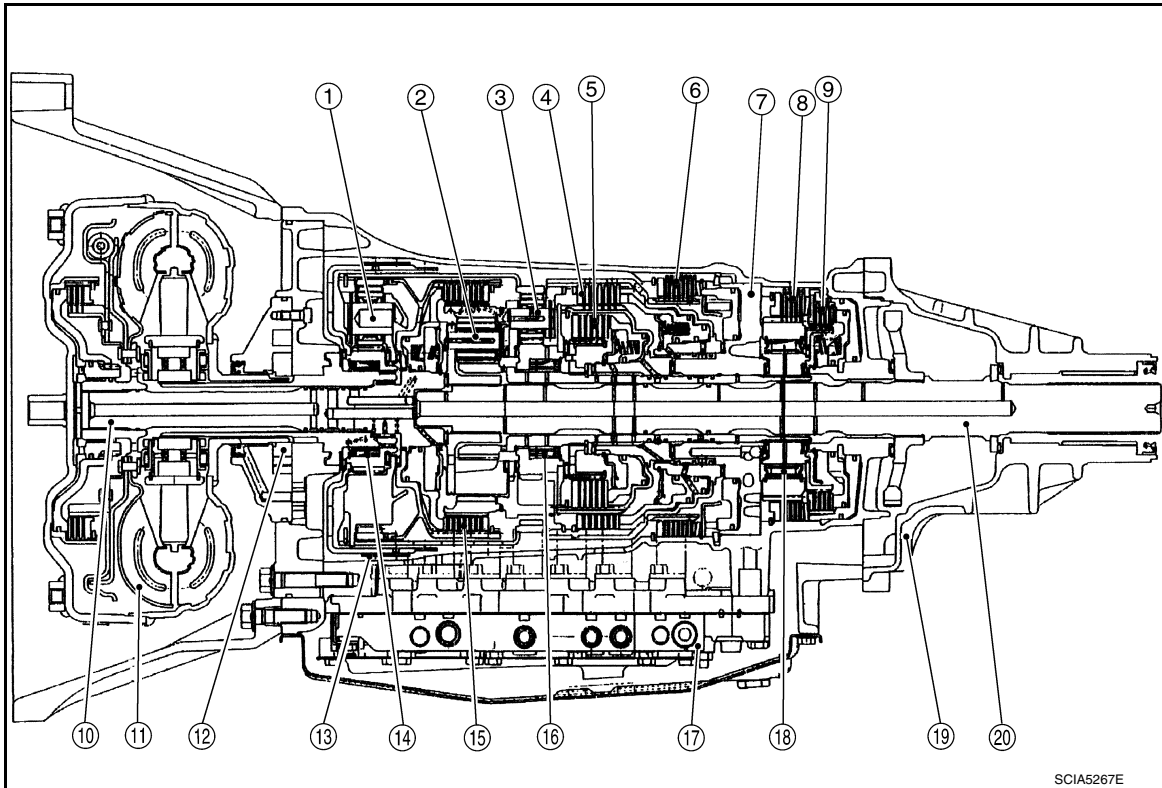

- |                         |                              |                            |
|-------------------------|------------------------------|----------------------------|
| 1. Front planetary gear | 2. Mid planetary gear        | 3. Rear planetary gear     |
| 4. Direct clutch        | 5. High & low reverse clutch | 6. Reverse brake           |
| 7. Drum support         | 8. Forward brake             | 9. Low coast brake         |
| 10. Input shaft         | 11. Torque converter         | 12. Oil pump               |
| 13. Front brake         | 14. 3rd one-way clutch       | 15. Input clutch           |
| 16. 1st one-way clutch  | 17. Control valve with TCM   | 18. Forward one-way clutch |
| 19. Rear extension      | 20. Output shaft             |                            |

# A/T CONTROL SYSTEM

< SYSTEM DESCRIPTION >

## Cross-Sectional View (4WD models)

INFOID:000000009885682

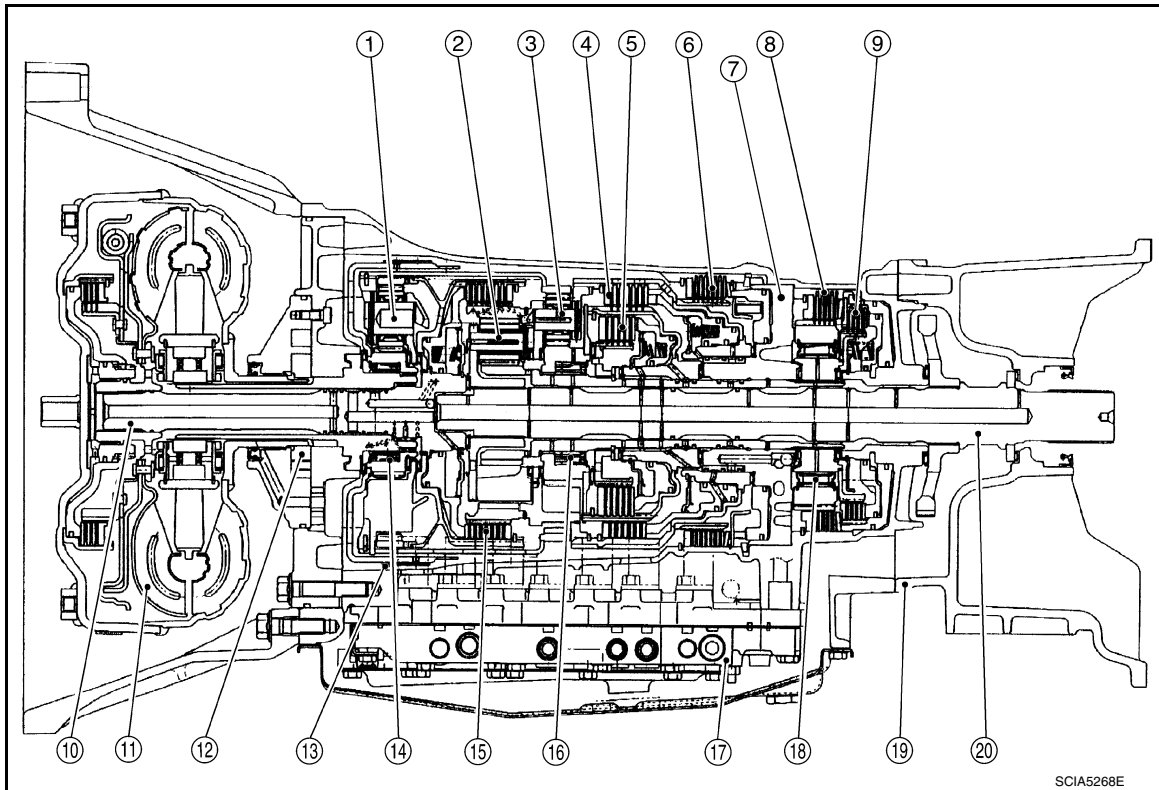

- |                         |                              |                            |
|-------------------------|------------------------------|----------------------------|
| 1. Front planetary gear | 2. Mid planetary gear        | 3. Rear planetary gear     |
| 4. Direct clutch        | 5. High & low reverse clutch | 6. Reverse brake           |
| 7. Drum support         | 8. Forward brake             | 9. Low coast brake         |
| 10. Input shaft         | 11. Torque converter         | 12. Oil pump               |
| 13. Front brake         | 14. 3rd one-way clutch       | 15. Input clutch           |
| 16. 1st one-way clutch  | 17. Control valve with TCM   | 18. Forward one-way clutch |
| 19. Adapter case        | 20. Output shaft             |                            |

## Shift Mechanism

INFOID:000000009885683

The automatic transmission uses compact dual planetary gear systems to improve power-transmission efficiency, simplify construction and reduce weight. It also employs an optimum shift control and super wide gear ratios. They improve starting performance and acceleration during medium and high-speed operation.

## CONSTRUCTION

# A/T CONTROL SYSTEM

## < SYSTEM DESCRIPTION >

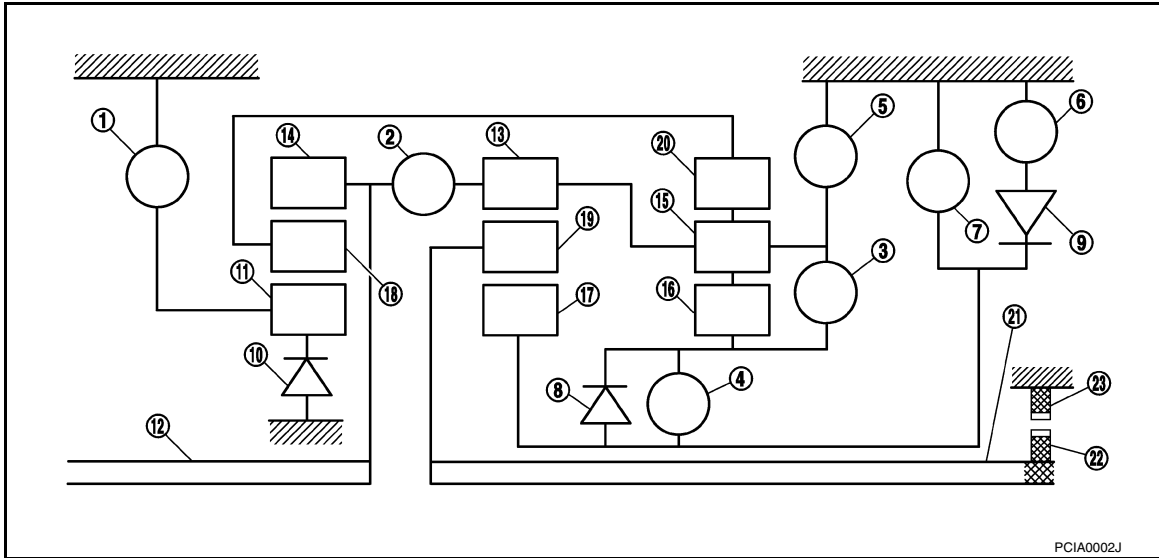

- |                                |                         |                           |
|--------------------------------|-------------------------|---------------------------|
| 1. Front brake                 | 2. Input clutch         | 3. Direct clutch          |
| 4. High and low reverse clutch | 5. Reverse brake        | 6. Forward brake          |
| 7. Low coast brake             | 8. 1st one-way clutch   | 9. Forward one-way clutch |
| 10. 3rd one-way clutch         | 11. Front sun gear      | 12. Input shaft           |
| Mid internal gear              | 14. Front internal gear | 15. Rear carrier          |
| 13.                            |                         |                           |
| 16. Rear sun gear              | 17. Mid sun gear        | 18. Front carrier         |
| 19. Mid carrier                | 20. Rear internal gear  | 21. Output shaft          |
| 22. Parking gear               | 23. Parking pawl        |                           |

## FUNCTION OF CLUTCH AND BRAKE

Name of the Part	Abbreviation	Function
Front brake (1)	FR/B	Fastens the front sun gear (11).
Input clutch (2)	I/C	Connects the input shaft (12), the front internal gear (14) and the mid internal gear (13).
Direct clutch (3)	D/C	Connects the rear carrier (15) and the rear sun gear (16).
High and low reverse clutch (4)	HLR/C	Connects the mid sun gear (17) and the rear sun gear (16).
Reverse brake (5)	R/B	Fastens the rear carrier (15).
Forward brake (6)	F/B	Fastens the mid sun gear (17).
Low coast brake (7)	LC/B	Fastens the mid sun gear (17).
1st one-way clutch (8)	1st/O.C	Allows the rear sun gear (16) to turn freely forward relative to the mid sun gear (17) but fastens it for reverse rotation.
Forward one-way clutch (9)	F/O.C	Allows the mid sun gear (17) to turn freely in the forward direction but fastens it for reverse rotation.
3rd one-way clutch (10)	3rd/O.C	Allows the front sun gear (11) to turn freely in the forward direction but fastens it for reverse rotation.

## CLUTCH AND BAND CHART (FLOOR SHIFT MODELS)

Shift position	I/C	HLR/C	D/C	R/B	FR/B	LC/B	Fwd/B	1st OWC	Fwd OWC	3rd OWC	Remarks
P		△			△						PARK POSITION
R		○		○	○			☆		☆	REVERSE POSITION

# A/T CONTROL SYSTEM

## < SYSTEM DESCRIPTION >

Shift position	I/C	HLR/C	D/C	R/B	FR/B	LC/B	Fwd/B	1st OWC	Fwd OWC	3rd OWC	Remarks
N		△			△						NEUTRAL POSITION
D	1st	△*			△	△**	○	☆	☆	☆	Automatic shift 1↔2↔3↔4↔5
	2nd		○		△		○		☆	☆	
	3rd	○	○		○		△	★		☆	
	4th	○	○	○			△	★			
	5th	○	○		○		△	★		★	
4	1st	△*			△	△**	○	☆	☆	☆	Automatic shift 1↔2↔3↔4
	2nd		○		△		○		☆	☆	
	3rd	○	○		○		△	★		☆	
	4th	○	○	○			△	★			
3	1st	△*			△	△**	○	☆	☆	☆	Automatic shift 1↔2↔3↔4
	2nd		○		△		○		☆	☆	
	3rd	○	○		○		△	★		☆	
	4th	○	○	○			△	★			
2	1st	△*			△	△**	○	☆	☆	☆	Automatic shift 1↔2↔3↔4
	2nd		○		○	○	○		☆	☆	
	3rd	○	○		○		△	★		☆	
	4th	○	○	○			△	★			
1	1st	○			○	○	○	☆	☆	☆	Locks (held stationary in 1GR) 1↔2↔3↔4
	2nd		○		○	○	○		☆	☆	
	3rd	○	○		○		△	★		☆	
	4th	○	○	○			△	★			

- ○—Operates
- ☆—Operates during “progressive” acceleration.
- ★—Operates and effects power transmission while coasting.
- △—Line pressure is applied but does not affect power transmission.
- △\*—Operates under conditions shown in HLR/C Operating Condition
- △\*\*—Operates under conditions shown in LC/B Operating Condition. Delay control is applied during D (4,3,2,1) ⇒N shift.

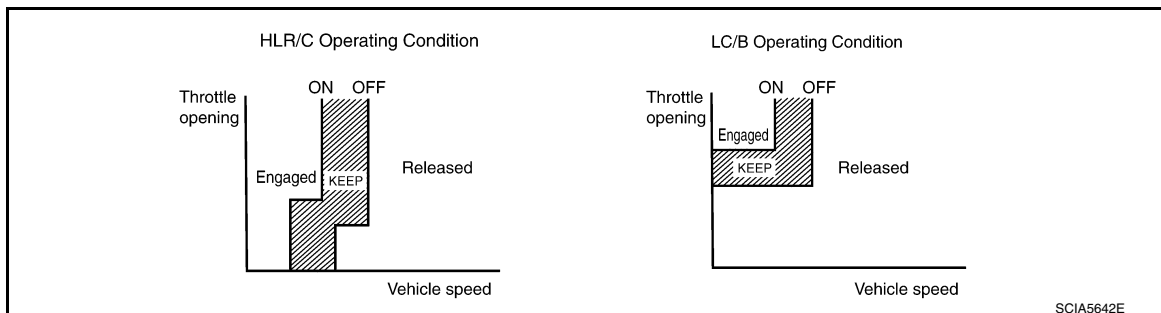

**CLUTCH AND BAND CHART (COLUMN SHIFT MODELS)**

# A/T CONTROL SYSTEM

## < SYSTEM DESCRIPTION >

Shift position	I/C	HLR/C	D/C	R/B	FR/B	LC/B	Fwd/B	1st OWC	Fwd OWC	3rd OWC	Remarks
P		△			△						PARK POSITION
R		○		○	○			☆		☆	REVERSE POSITION
N		△			△						NEUTRAL POSITION
D	1st	△*			△	△**	○	☆	☆	☆	Automatic shift 1↔2↔3↔4↔5
	2nd		○		△		○		☆	☆	
	3rd	○	○		○		△	★		☆	
	4th	○	○	○			△	★			
	5th	○	○		○		△	★		★	
M5	1st	△*			△	△**	○	☆	☆	☆	Automatic shift 1↔2↔3↔4↔5
	2nd		○		△		○		☆	☆	
	3rd	○	○		○		△	★		☆	
	4th	○	○	○			△	★			
	5th	○	○		○		△	★		★	
M4	1st	△*			△	△**	○	☆	☆	☆	Automatic shift 1↔2↔3↔4
	2nd		○		△		○		☆	☆	
	3rd	○	○		○		△	★		☆	
	4th	○	○	○			△	★			
M3	1st	△*			△	△**	○	☆	☆	☆	Automatic shift 1↔2↔3
	2nd		○		△		○		☆	☆	
	3rd	○	○		○		△	★		☆	
M2	1st	△*			△	△**	○	☆	☆	☆	Automatic shift 1↔2
	2nd		○		○	○	○		☆	☆	
M1	1st	○			○	○	○	☆	☆	☆	Locks (held stationary in 1GR)
	2nd		○		○	○	○		☆	☆	

- ○—Operates
- ☆—Operates during “progressive” acceleration.
- ★—Operates and effects power transmission while coasting.
- △—Line pressure is applied but does not affect power transmission.
- △\*—Operates under conditions shown in HLR/C Operating Condition
- △\*\*—Operates under conditions shown in LC/B Operating Condition. Delay control is applied during D (4,3,2,1) ⇒N shift.

# A/T CONTROL SYSTEM

## < SYSTEM DESCRIPTION >

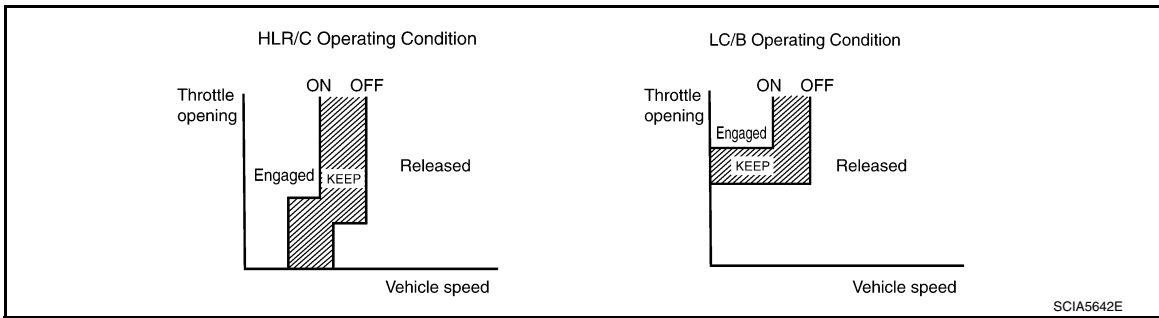

## POWER TRANSMISSION

### “N” position

Since both the forward brake and the reverse brake are released, torque from the input shaft drive is not transmitted to the output shaft.

### “P” position

- The same as for the “N” position, both the forward brake and the reverse brake are released, so torque from the input shaft drive is not transmitted to the output shaft.
- The parking pawl linked with the select lever meshes with the parking gear and fastens the output shaft mechanically.

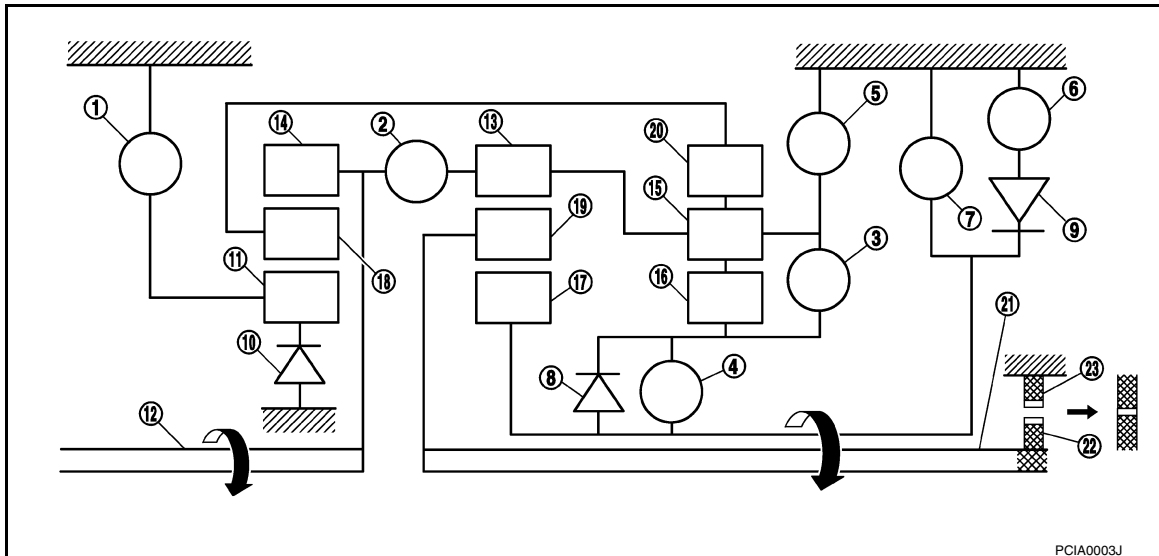

- |                                |                         |                           |
|--------------------------------|-------------------------|---------------------------|
| 1. Front brake                 | 2. Input clutch         | 3. Direct clutch          |
| 4. High and low reverse clutch | 5. Reverse brake        | 6. Forward brake          |
| 7. Low coast brake             | 8. 1st one-way clutch   | 9. Forward one-way clutch |
| 10. 3rd one-way clutch         | 11. Front sun gear      | 12. Input shaft           |
| 13. Mid internal gear          | 14. Front internal gear | 15. Rear carrier          |
| 16. Rear sun gear              | 17. Mid sun gear        | 18. Front carrier         |
| 19. Mid carrier                | 20. Rear internal gear  | 21. Output shaft          |
| 22. Parking gear               | 23. Parking pawl        |                           |

### “D”, “M5”, “M4”, “M3”, “M2” positions (column shift), “D”, “4”, “3”, “2” positions (floor shift) 1GR

- The forward brake and the forward one-way clutch regulate reverse rotation of the mid sun gear.
- The 1st one-way clutch regulates reverse rotation of the rear sun gear.
- The 3rd one-way clutch regulates reverse rotation of the front sun gear.
- During deceleration, the mid sun gear turns forward, so the forward one-way clutch idles and the engine brake is not activated.

# A/T CONTROL SYSTEM

## < SYSTEM DESCRIPTION >

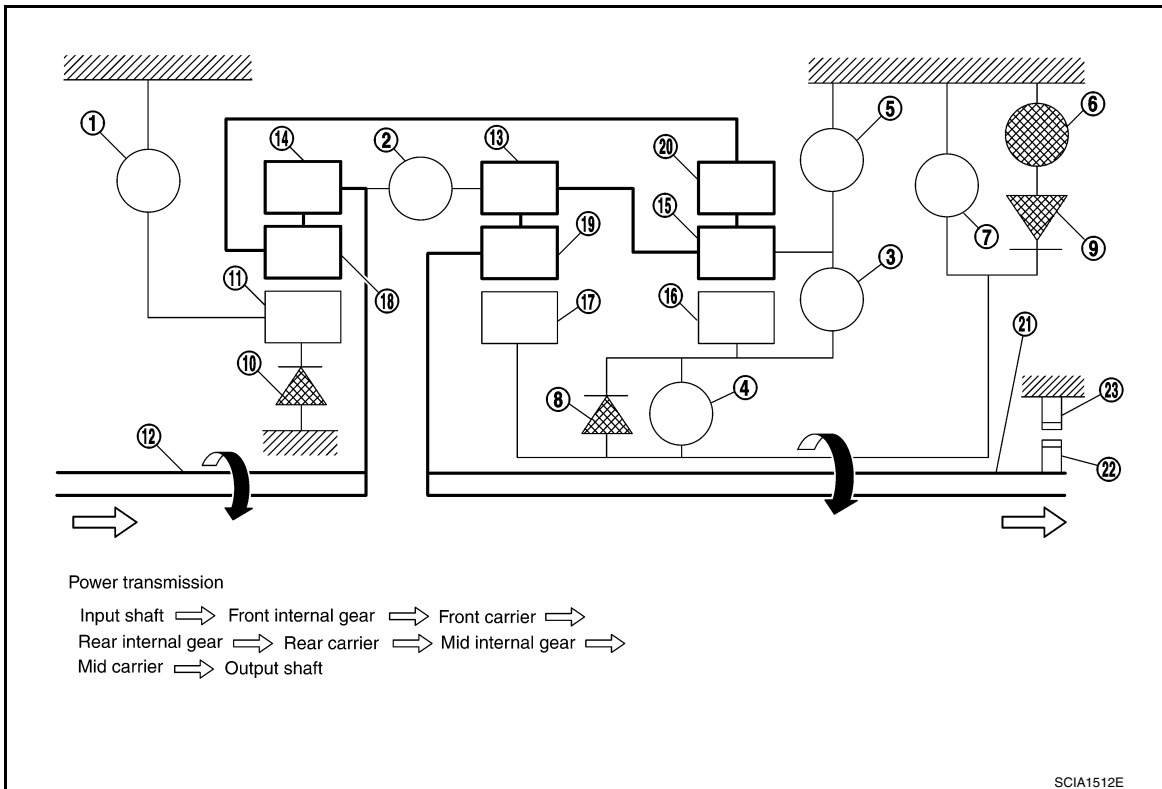

- |                                |                         |                           |
|--------------------------------|-------------------------|---------------------------|
| 1. Front brake                 | 2. Input clutch         | 3. Direct clutch          |
| 4. High and low reverse clutch | 5. Reverse brake        | 6. Forward brake          |
| 7. Low coast brake             | 8. 1st one-way clutch   | 9. Forward one-way clutch |
| 10. 3rd one-way clutch         | 11. Front sun gear      | 12. Input shaft           |
| 13. Mid internal gear          | 14. Front internal gear | 15. Rear carrier          |
| 16. Rear sun gear              | 17. Mid sun gear        | 18. Front carrier         |
| 19. Mid carrier                | 20. Rear internal gear  | 21. Output shaft          |
| 22. Parking gear               | 23. Parking pawl        |                           |

“M1” position (column shift), “1” position (floor shift) 1GR

- The front brake fastens the front sun gear.
- The forward brake and the forward one-way clutch regulate reverse rotation of the mid sun gear.
- High and low reverse clutch connects the rear sun gear and the mid sun gear.
- The low coast brake fastens the mid sun gear.
- During deceleration, the low coast brake regulates forward rotation of the mid sun gear and the engine brake functions.



# A/T CONTROL SYSTEM

## < SYSTEM DESCRIPTION >

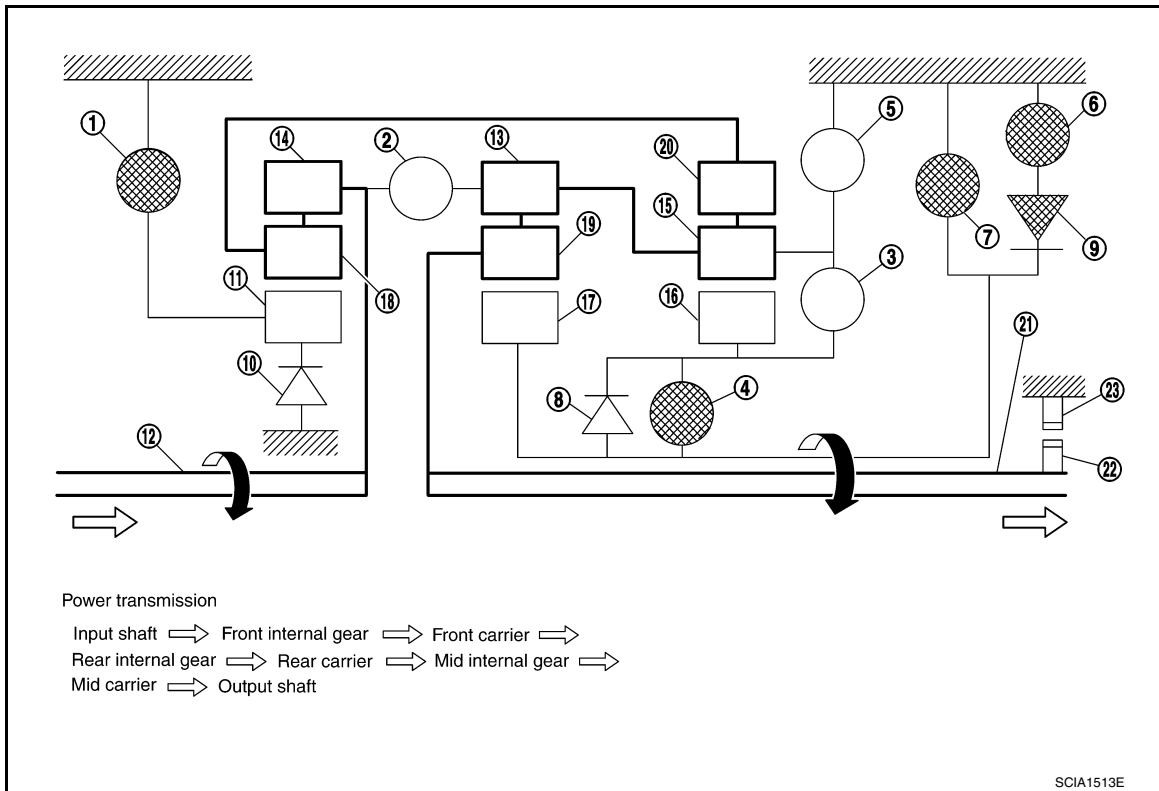

- |                                |                         |                           |
|--------------------------------|-------------------------|---------------------------|
| 1. Front brake                 | 2. Input clutch         | 3. Direct clutch          |
| 4. High and low reverse clutch | 5. Reverse brake        | 6. Forward brake          |
| 7. Low coast brake             | 8. 1st one-way clutch   | 9. Forward one-way clutch |
| 10. 3rd one-way clutch         | 11. Front sun gear      | 12. Input shaft           |
| 13. Mid internal gear          | 14. Front internal gear | 15. Rear carrier          |
| 16. Rear sun gear              | 17. Mid sun gear        | 18. Front carrier         |
| 19. Mid carrier                | 20. Rear internal gear  | 21. Output shaft          |
| 22. Parking gear               | 23. Parking pawl        |                           |

“D”, “M5”, “M4”, “M3” positions (column shift), “D”, “4”, “3” positions (floor shift) 2GR

- The forward brake and the forward one-way clutch regulate reverse rotation of the mid sun gear.
- The 3rd one-way clutch regulates reverse rotation of the front sun gear.
- The direct clutch is coupled and the rear carrier and rear sun gear are connected.
- During deceleration, the mid sun gear turns forward, so the forward one-way clutch idles and engine brake is not activated.

# A/T CONTROL SYSTEM

## < SYSTEM DESCRIPTION >

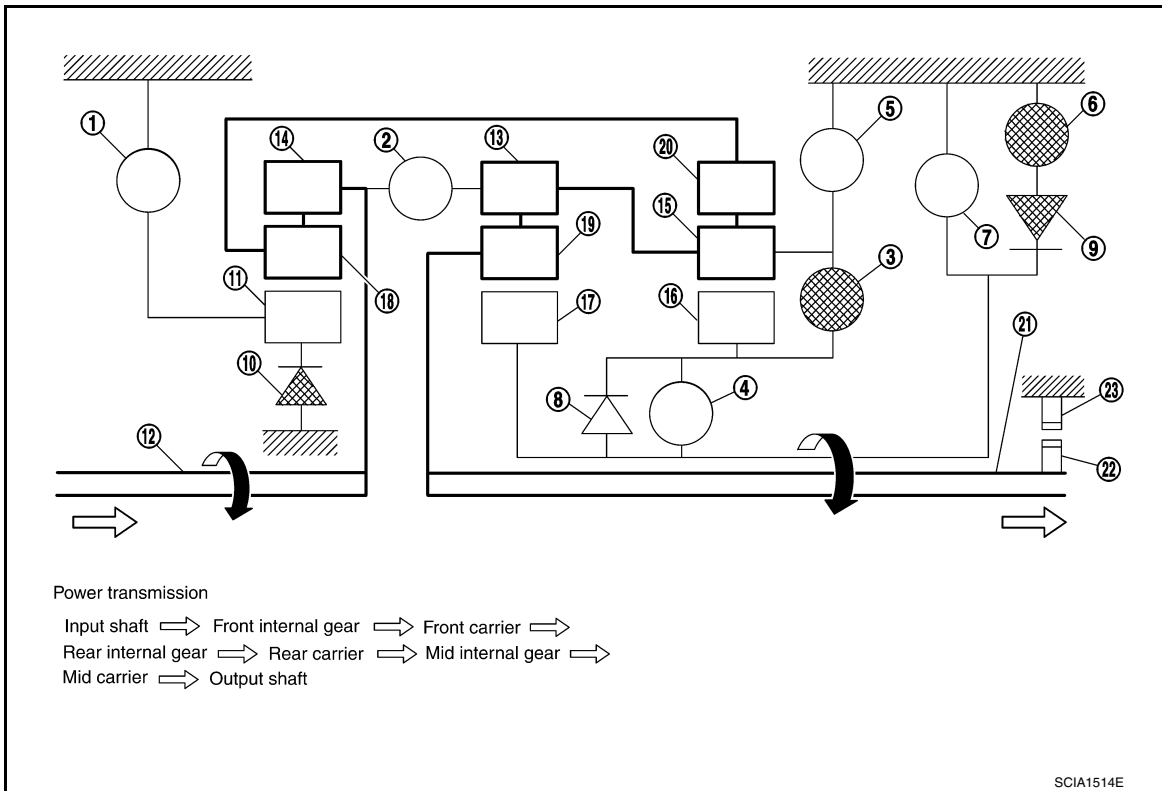

- |                                |                         |                           |
|--------------------------------|-------------------------|---------------------------|
| 1. Front brake                 | 2. Input clutch         | 3. Direct clutch          |
| 4. High and low reverse clutch | 5. Reverse brake        | 6. Forward brake          |
| 7. Low coast brake             | 8. 1st one-way clutch   | 9. Forward one-way clutch |
| 10. 3rd one-way clutch         | 11. Front sun gear      | 12. Input shaft           |
| 13. Mid internal gear          | 14. Front internal gear | 15. Rear carrier          |
| 16. Rear sun gear              | 17. Mid sun gear        | 18. Front carrier         |
| 19. Mid carrier                | 20. Rear internal gear  | 21. Output shaft          |
| 22. Parking gear               | 23. Parking pawl        |                           |

“M2”, “M1” positions (column shift), “2”, “1” positions (floor shift) 2GR

- The front brake fastens the front sun gear.
- The forward brake and the forward one-way clutch regulate reverse rotation of the mid sun gear.
- The direct clutch is coupled, and the rear carrier and rear sun gear are connected.
- The low coast brake fastens the mid sun gear.
- During deceleration, the low coast brake regulates forward rotation of the mid sun gear and the engine brake functions.

# A/T CONTROL SYSTEM

## < SYSTEM DESCRIPTION >

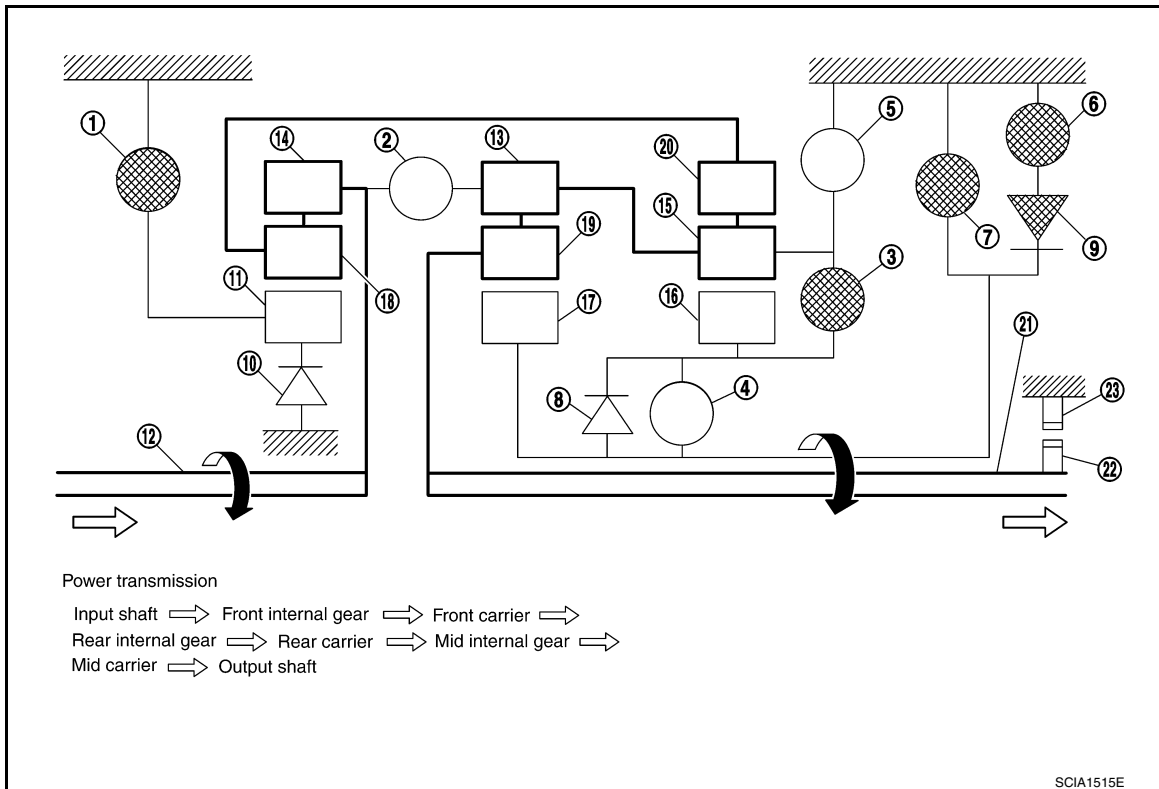

- |                                |                         |                           |
|--------------------------------|-------------------------|---------------------------|
| 1. Front brake                 | 2. Input clutch         | 3. Direct clutch          |
| 4. High and low reverse clutch | 5. Reverse brake        | 6. Forward brake          |
| 7. Low coast brake             | 8. 1st one-way clutch   | 9. Forward one-way clutch |
| 10. 3rd one-way clutch         | 11. Front sun gear      | 12. Input shaft           |
| 13. Mid internal gear          | 14. Front internal gear | 15. Rear carrier          |
| 16. Rear sun gear              | 17. Mid sun gear        | 18. Front carrier         |
| 19. Mid carrier                | 20. Rear internal gear  | 21. Output shaft          |
| 22. Parking gear               | 23. Parking pawl        |                           |

“D”, “M5”, “M4”, “M3” positions (column shift), “D”, “4”, “3” positions (floor shift) 3GR

- The front brake fastens the front sun gear.
- The direct clutch is coupled, and the rear carrier and rear sun gear are connected.
- The high and low reverse clutch is coupled and the mid sun gear and rear sun gear are connected.

# A/T CONTROL SYSTEM

## < SYSTEM DESCRIPTION >

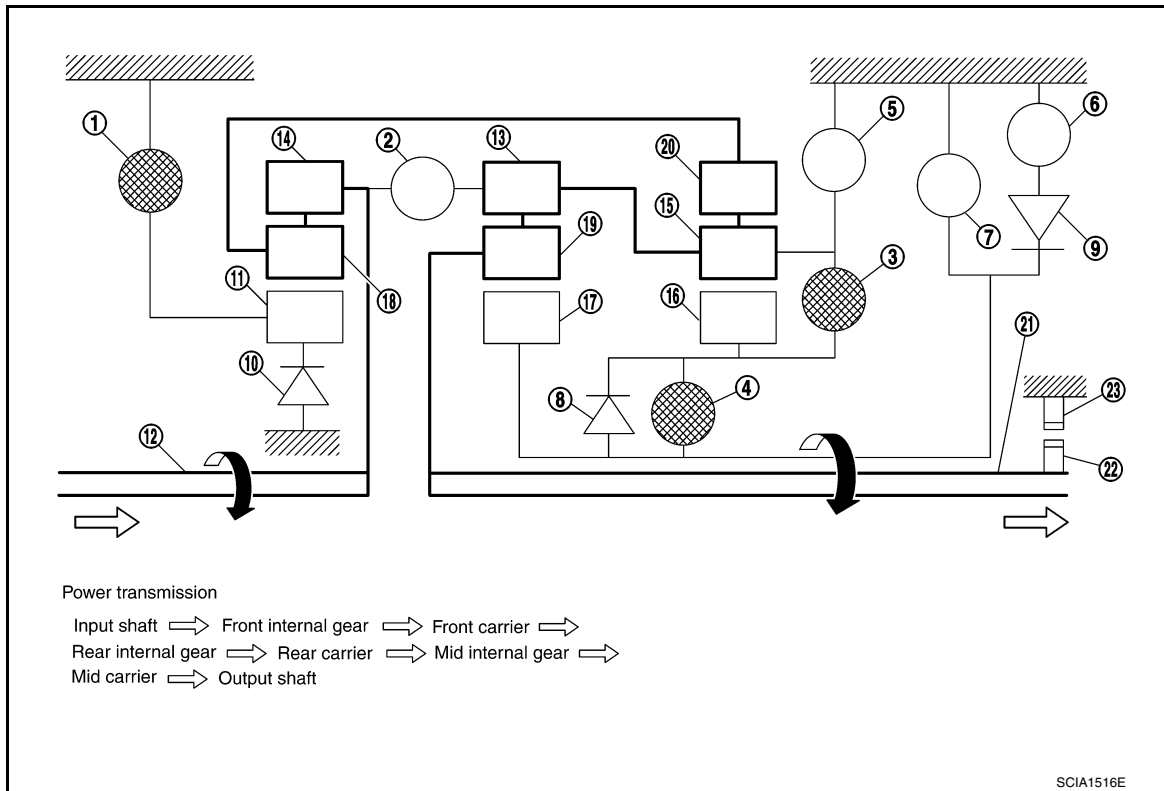

- |                                |                         |                           |
|--------------------------------|-------------------------|---------------------------|
| 1. Front brake                 | 2. Input clutch         | 3. Direct clutch          |
| 4. High and low reverse clutch | 5. Reverse brake        | 6. Forward brake          |
| 7. Low coast brake             | 8. 1st one-way clutch   | 9. Forward one-way clutch |
| 10. 3rd one-way clutch         | 11. Front sun gear      | 12. Input shaft           |
| 13. Mid internal gear          | 14. Front internal gear | 15. Rear carrier          |
| 16. Rear sun gear              | 17. Mid sun gear        | 18. Front carrier         |
| 19. Mid carrier                | 20. Rear internal gear  | 21. Output shaft          |
| 22. Parking gear               | 23. Parking pawl        |                           |

“D”, “M5”, “M4” positions (column shift), “D”, “4” positions (floor shift) 4GR

- The direct clutch is coupled, and the rear carrier and rear sun gear are connected.
- The high and low reverse clutch is coupled and the mid sun gear and rear sun gear are connected.
- The input clutch is coupled and the front internal gear and mid internal gear are connected.
- The drive power is conveyed to the front internal gear, mid internal gear, and rear carrier and the three planetary gears rotate forward as one unit.

# A/T CONTROL SYSTEM

## < SYSTEM DESCRIPTION >

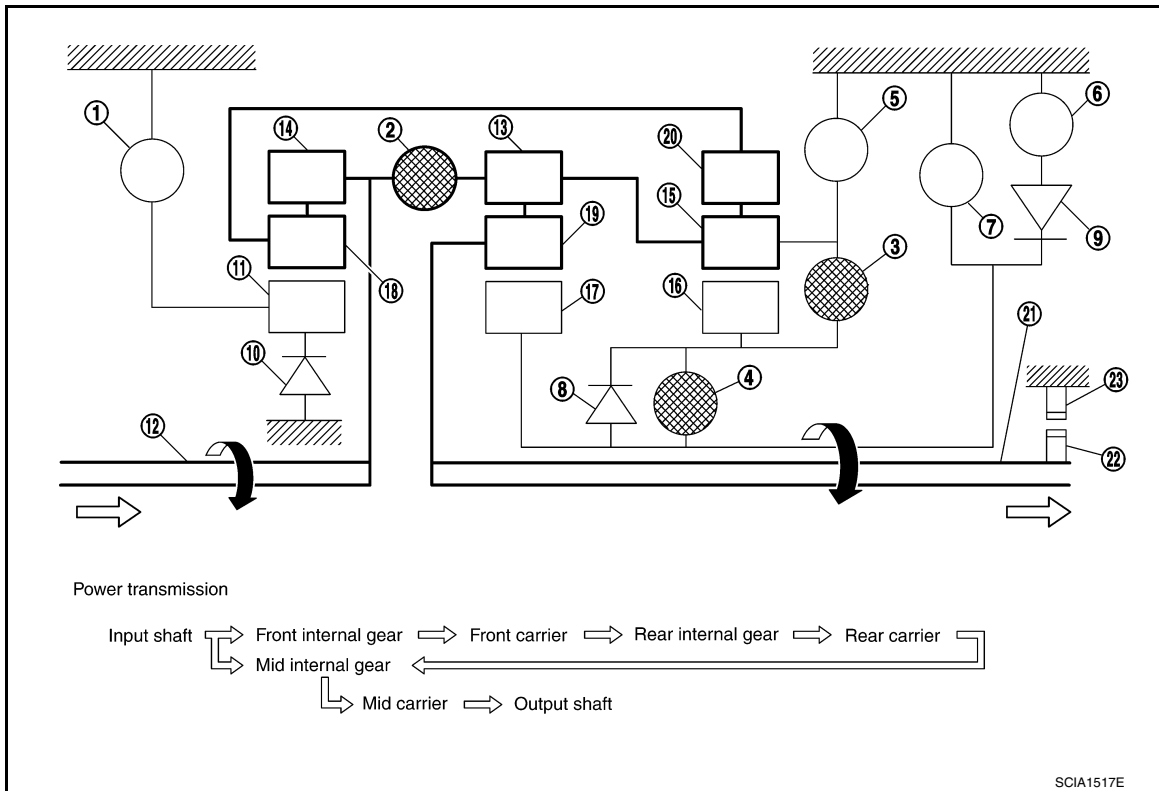

- |                                |                         |                           |
|--------------------------------|-------------------------|---------------------------|
| 1. Front brake                 | 2. Input clutch         | 3. Direct clutch          |
| 4. High and low reverse clutch | 5. Reverse brake        | 6. Forward brake          |
| 7. Low coast brake             | 8. 1st one-way clutch   | 9. Forward one-way clutch |
| 10. 3rd one-way clutch         | 11. Front sun gear      | 12. Input shaft           |
| 13. Mid internal gear          | 14. Front internal gear | 15. Rear carrier          |
| 16. Rear sun gear              | 17. Mid sun gear        | 18. Front carrier         |
| 19. Mid carrier                | 20. Rear internal gear  | 21. Output shaft          |
| 22. Parking gear               | 23. Parking pawl        |                           |

“D”, “M5” positions (column shift), “D” position (floor shift) 5GR

- The front brake fastens the front sun gear.
- The input clutch is coupled and the front internal gear and mid internal gear are connected.
- The high and low reverse clutch is coupled and the mid sun gear and rear sun gear are connected.

# A/T CONTROL SYSTEM

## < SYSTEM DESCRIPTION >

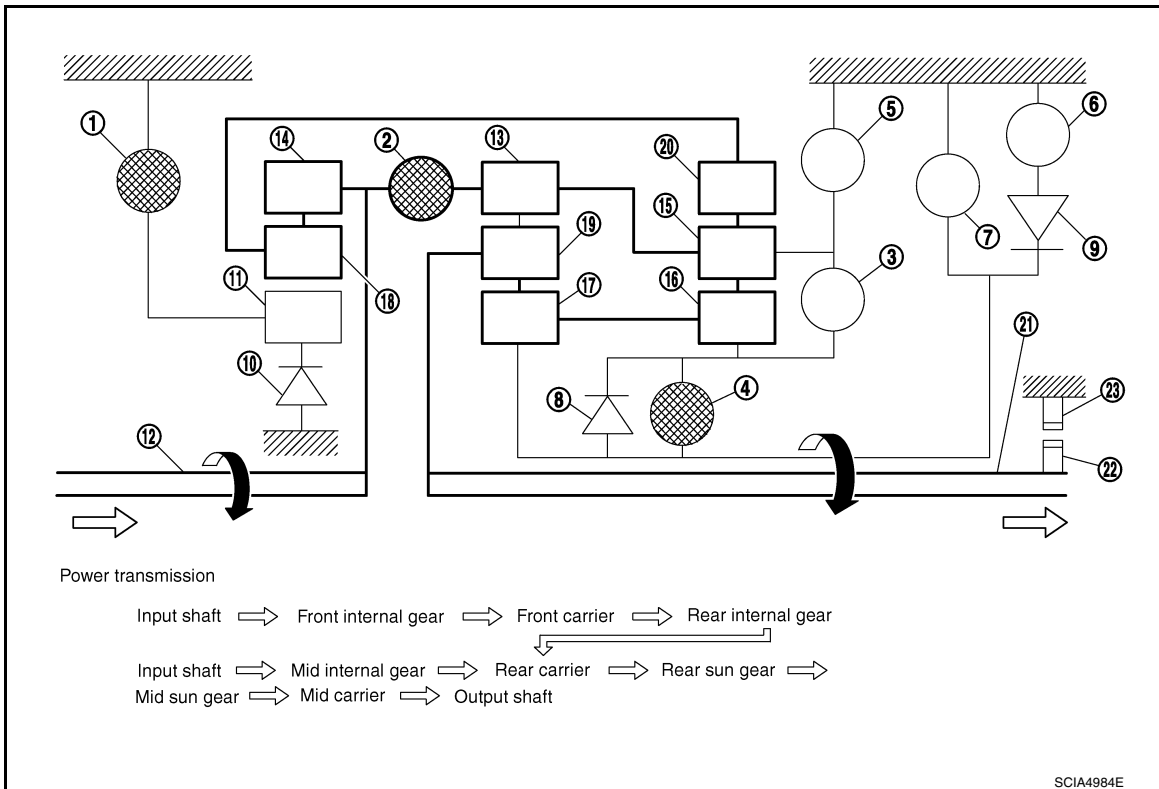

- |                                |                         |                           |
|--------------------------------|-------------------------|---------------------------|
| 1. Front brake                 | 2. Input clutch         | 3. Direct clutch          |
| 4. High and low reverse clutch | 5. Reverse brake        | 6. Forward brake          |
| 7. Low coast brake             | 8. 1st one-way clutch   | 9. Forward one-way clutch |
| 10. 3rd one-way clutch         | 11. Front sun gear      | 12. Input shaft           |
| 13. Mid internal gear          | 14. Front internal gear | 15. Rear carrier          |
| 16. Rear sun gear              | 17. Mid sun gear        | 18. Front carrier         |
| 19. Mid carrier                | 20. Rear internal gear  | 21. Output shaft          |
| 22. Parking gear               | 23. Parking pawl        |                           |

### "R" position

- The front brake fastens the front sun gear.
- The high and low reverse clutch is coupled, and the mid sun gear and rear sun gear are connected.
- The reverse brake fastens the rear carrier.

# A/T CONTROL SYSTEM

## < SYSTEM DESCRIPTION >

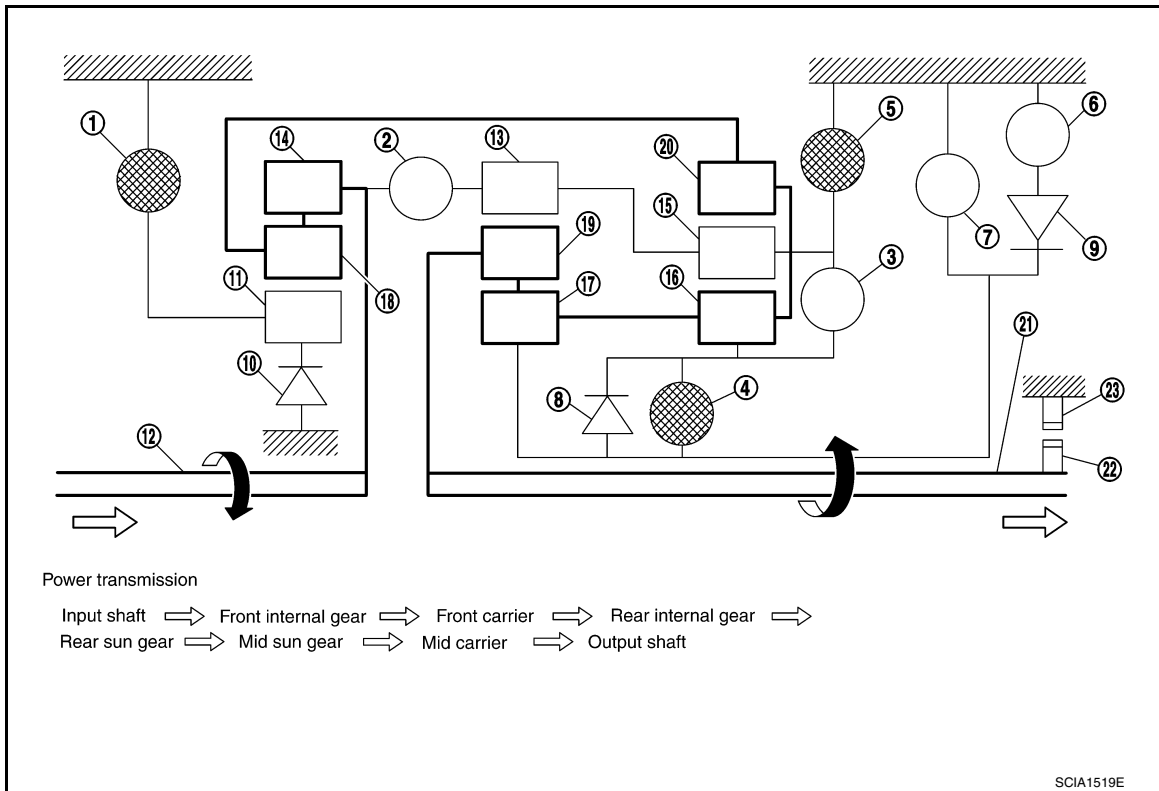

- |                                |                         |                           |
|--------------------------------|-------------------------|---------------------------|
| 1. Front brake                 | 2. Input clutch         | 3. Direct clutch          |
| 4. High and low reverse clutch | 5. Reverse brake        | 6. Forward brake          |
| 7. Low coast brake             | 8. 1st one-way clutch   | 9. Forward one-way clutch |
| 10. 3rd one-way clutch         | 11. Front sun gear      | 12. Input shaft           |
| 13. Mid internal gear          | 14. Front internal gear | 15. Rear carrier          |
| 16. Rear sun gear              | 17. Mid sun gear        | 18. Front carrier         |
| 19. Mid carrier                | 20. Rear internal gear  | 21. Output shaft          |
| 22. Parking gear               | 23. Parking pawl        |                           |

## TCM Function

INFOID:000000009885684

The function of the TCM is to:

- Receive input signals sent from various switches and sensors.
- Determine required line pressure, shifting point, lock-up operation, and engine brake operation.
- Send required output signals to the respective solenoids.

## CONTROL SYSTEM OUTLINE

The automatic transmission senses vehicle operating conditions through various sensors or signals. It always controls the optimum shift position and reduces shifting and lock-up shocks.

# A/T CONTROL SYSTEM

## < SYSTEM DESCRIPTION >

SENSORS (or SIGNALS)		TCM		ACTUATORS
Transmission range switch Accelerator pedal position sensor Closed throttle position signal Wide open throttle position signal Engine speed signal A/T fluid temperature sensor Output speed sensor Vehicle speed signal Manual mode switch signal*2 Stop lamp switch signal Input speed sensor 1st position switch signal*1 4th position switch signal*1 ATF pressure switch 2 signal Tow mode switch signal	⇒	Shift control Line pressure control Lock-up control Engine brake control Timing control Fail-safe control Self-diagnosis CONSULT communication line Duet-EA control CAN system	⇒	Input clutch solenoid valve Direct clutch solenoid valve Front brake solenoid valve High and low reverse clutch solenoid valve Low coast brake solenoid valve Torque converter clutch solenoid valve Line pressure solenoid valve A/T CHECK indicator lamp Starter relay Back-up lamp relay

\*1: Floor shift models

\*2: Column shift models

## CONTROL SYSTEM DIAGRAM

### Floor Shift Models

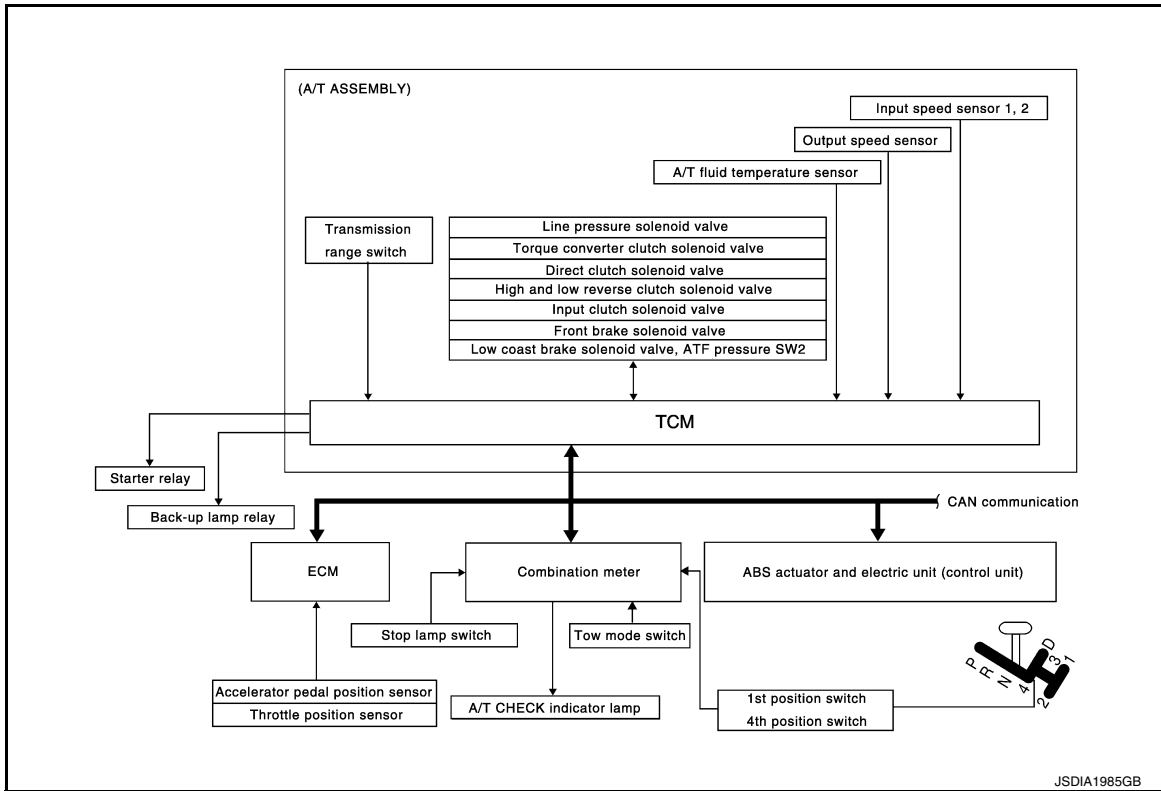



# A/T CONTROL SYSTEM

## < SYSTEM DESCRIPTION >

### Column Shift Models

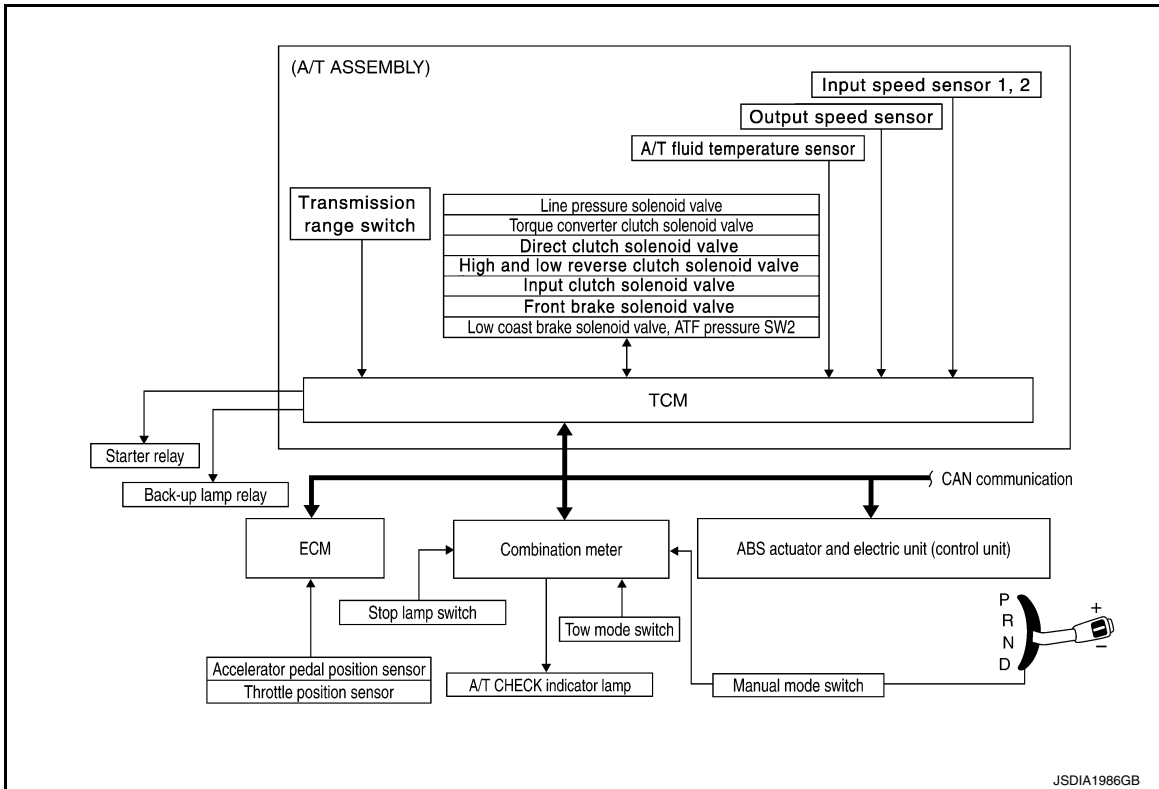

## CAN Communication

INFOID:000000009885685

### SYSTEM DESCRIPTION

CAN (Controller Area Network) is a serial communication line for real time application. It is an on-vehicle multiplex communication line with high data communication speed and excellent error detection ability. Many electronic control units are equipped onto a vehicle, and each control unit shares information and links with other control units during operation (not independent). In CAN communication, control units are connected with 2 communication lines (CAN H line, CAN L line) allowing a high rate of information transmission with less wiring. Each control unit transmits/receives data but selectively reads required data only. For details, refer to [LAN-46, "CAN System Specification Chart"](#).

# A/T CONTROL SYSTEM

< SYSTEM DESCRIPTION >

## Input/Output Signal of TCM

INFOID:000000009885686

Control item		Line pressure control	Vehicle speed control	Shift control	Lock-up control	Engine brake control	Fail-safe function (*3)	Self-diagnostics function	
Input	Accelerator pedal position signal (*4)	X	X	X	X	X	X	X	
	Output speed sensor	X	X	X	X		X	X	
	Vehicle speed signal(*1) (*4)	X	X	X	X			X	
	Closed throttle position signal(*4)	(*2) X	(*2) X		X	(*2) X		(*5) X	
	Wide open throttle position signal(*4)	(*2) X	(*2) X			(*2) X		(*5) X	
	Input speed sensor 1	X	X		X		X	X	
	Input speed sensor 2 (for 4th speed only)	X	X		X		X	X	
	Engine speed signals(*4)				X			X	
	Transmission range switch	X	X	X	X	X	X	X	
	Stop lamp switch signal(*4)		X	X	X			(*5) X	
	A/T fluid temperature sensor	X	X	X	X	X	X	X	
	ASCD	Operation signal(*4)		X	X	X	X		
		Overdrive cancel signal(*4)		X		X	X		
	TCM power supply voltage signal		X	X	X	X	X		X
Output	Direct clutch solenoid		X	X			X	X	
	Input clutch solenoid		X	X			X	X	
	High and low reverse clutch solenoid		X	X			X	X	
	Front brake solenoid		X	X			X	X	
	Low coast brake solenoid (ATF pressure switch 2)		X	X		X	X	X	
	Line pressure solenoid	X	X	X	X	X	X	X	
	TCC solenoid				X		X	X	
	Starter relay						X	X	

\*1: Spare for output speed sensor.

\*2: Spare for accelerator pedal position signal.

\*3: If these input and output signals are different, the TCM triggers the fail-safe function.

\*4: CAN communications.

\*5: Used as a condition for starting self-diagnostics; If self-diagnostics are not started, it is judged that there is some kind of error.

## Line Pressure Control

INFOID:000000009885687

- When an input torque signal equivalent to the engine drive force is sent from the ECM to the TCM, the TCM controls the line pressure solenoid.

# A/T CONTROL SYSTEM

## < SYSTEM DESCRIPTION >

- This line pressure solenoid controls the pressure regulator valve as the signal pressure and adjusts the pressure of the operating oil discharged from the oil pump to the line pressure most appropriate to the driving state.

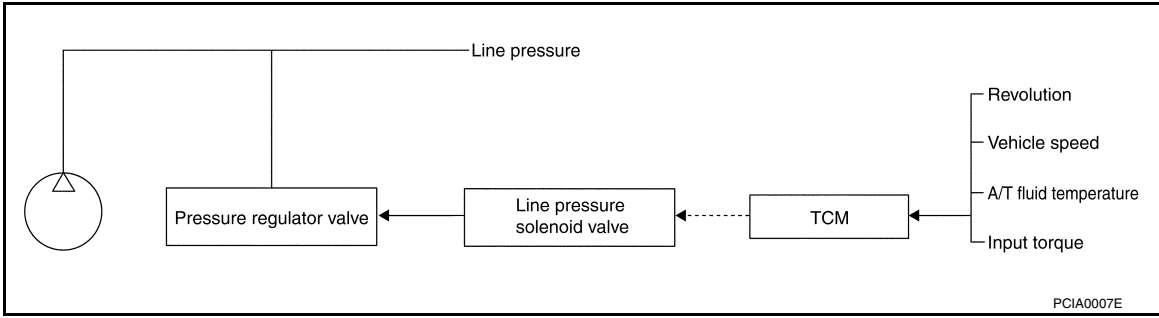

## LINE PRESSURE CONTROL IS BASED ON THE TCM LINE PRESSURE CHARACTERISTIC PATTERN

- The TCM has stored in memory a number of patterns for the optimum line pressure characteristic for the driving state.
- In order to obtain the most appropriate line pressure characteristic to meet the current driving state, the TCM controls the line pressure solenoid current value and thus controls the line pressure.

### Normal Control

Each clutch is adjusted to the necessary pressure to match the engine drive force.

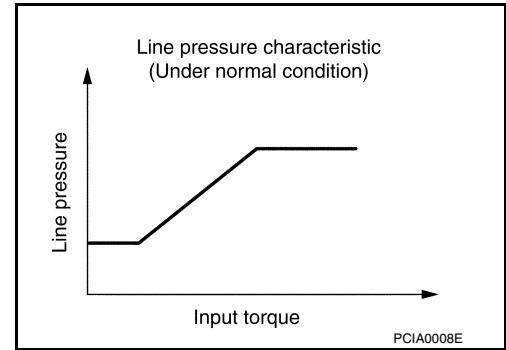

### Back-up Control (Engine Brake)

When the select operation is performed during driving and the transmission is shifted down, the line pressure is set according to the vehicle speed.

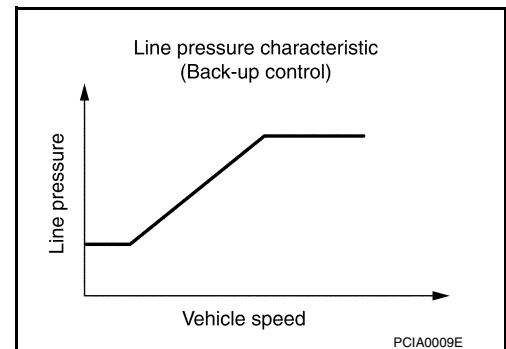

### During Shift Change

# A/T CONTROL SYSTEM

## < SYSTEM DESCRIPTION >

The necessary and adequate line pressure for shift change is set. For this reason, line pressure pattern setting corresponds to input torque and gearshift selection. Also, line pressure characteristic is set according to engine speed, during engine brake operation.

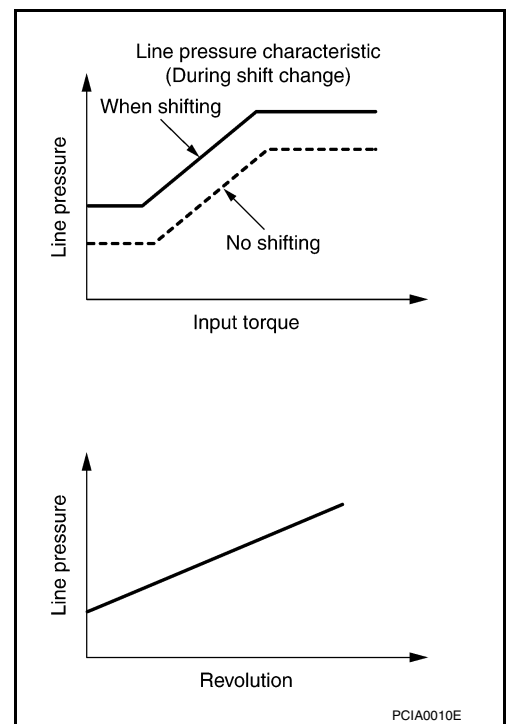

### At Low Fluid Temperature

When the A/T fluid temperature drops below the prescribed temperature, in order to speed up the action of each friction element, the line pressure is set higher than the normal line pressure characteristic.

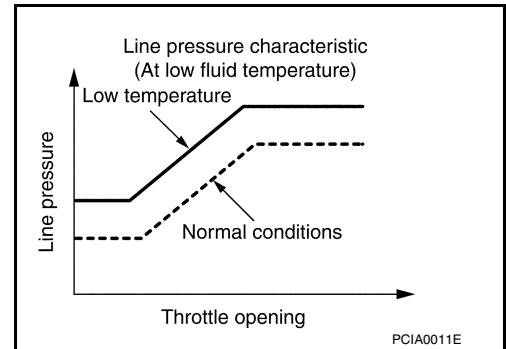

## Shift Control

INFOID:000000009885688

The clutch pressure control solenoid is controlled by the signals from the switches and sensors. Thus, the clutch pressure is adjusted to be appropriate to the engine load state and vehicle driving state. It becomes possible to finely control the clutch hydraulic pressure with high precision and a smoother shift change characteristic is attained.

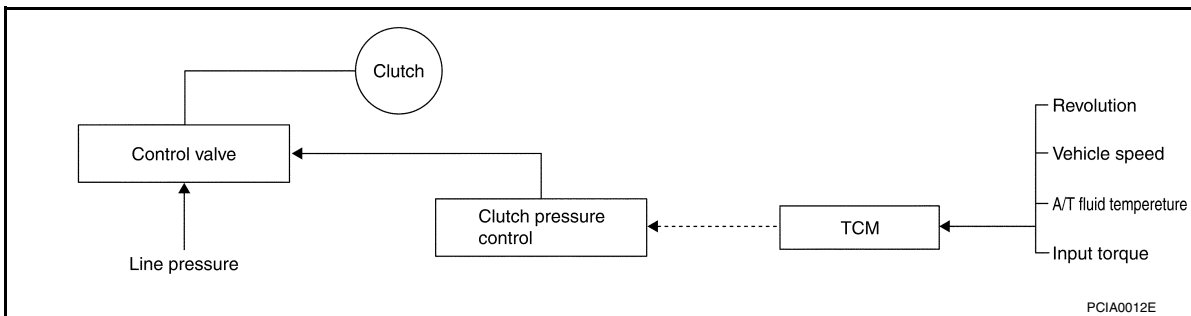

## SHIFT CHANGE

The clutch is controlled with the optimum timing and oil pressure by the engine speed, engine torque information, etc.

### Shift Change System Diagram

# A/T CONTROL SYSTEM

## < SYSTEM DESCRIPTION >

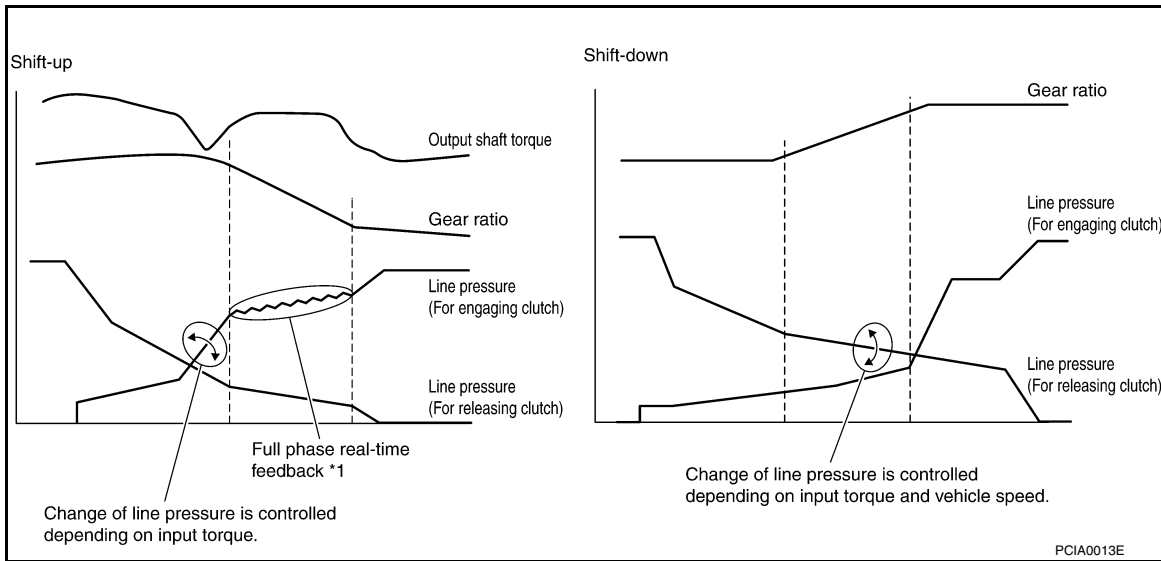

\*1: Full phase real-time feedback control monitors movement of gear ratio at gear change, and controls oil pressure at real-time to achieve the best gear ratio.

### Lock-up Control

INFOID:000000009885689

The torque converter clutch piston in the torque converter is engaged to eliminate torque converter slip to increase power transmission efficiency.

The torque converter clutch control valve operation is controlled by the torque converter clutch solenoid valve, which is controlled by a signal from TCM, and the torque converter clutch control valve engages or releases the torque converter clutch piston.

Lock-up Operation Condition Table (Floor Shift Models)

Select lever	D position			4 position	3 position	2 position
Gear position	5	4	3	4	3	2
Lock-up	×	×	×	×	—	—
Slip lock-up	—	—	×	—	—	—

Lock-up Operation Condition Table (Column Shift Models)

Select lever	D position			M position			
Gear position	5	4	3	5	4	3	2
Lock-up	×	×	×	×	×	—	—
Slip lock-up	—	—	×	—	—	—	—

## TORQUE CONVERTER CLUTCH CONTROL VALVE CONTROL

### Lock-up Control System Diagram

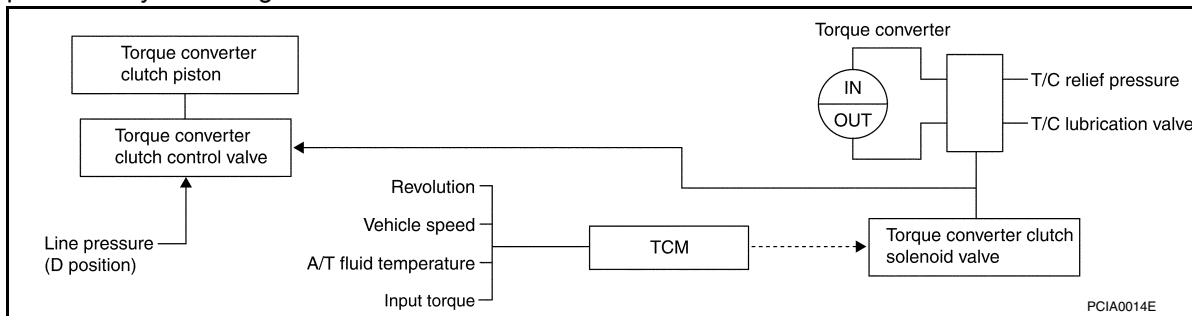

### Lock-up Released

- In the lock-up released state, the torque converter clutch control valve is set into the unlocked state by the torque converter clutch solenoid and the lock-up apply pressure is drained. In this way, the torque converter clutch piston is not coupled.

# A/T CONTROL SYSTEM

## < SYSTEM DESCRIPTION >

### Lock-up Applied

- In the lock-up applied state, the torque converter clutch control valve is set into the locked state by the torque converter clutch solenoid and lock-up apply pressure is generated. In this way, the torque converter clutch piston is pressed and coupled.

### SMOOTH LOCK-UP CONTROL

When shifting from the lock-up released state to the lock-up applied state, the current output to the torque converter clutch solenoid is controlled with the TCM. In this way, when shifting to the lock-up applied state, the torque converter clutch is temporarily set to the half-clutched state to reduce the shock.

### Half-clutched State

- The current output from the TCM to the torque converter clutch solenoid is varied to gradually increase the torque converter clutch solenoid pressure. In this way, the lock-up apply pressure gradually rises and while the torque converter clutch piston is put into half-clutched status, the torque converter clutch piston operating pressure is increased and the coupling is completed smoothly.

### Slip Lock-up Control

- In the slip region, the torque converter clutch solenoid current is controlled with the TCM to put it into the half-clutched state. This absorbs the engine torque fluctuation and lock-up operates from low speed. This raises the fuel efficiency for 4GR and 5GR at both low speed and when the accelerator has a low degree of opening.

## Engine Brake Control

INFOID:000000009885690

- The forward one-way clutch transmits the drive force from the engine to the rear wheels. But the reverse drive from the rear wheels is not transmitted to the engine because the one-way clutch is idling. Therefore, the low coast brake solenoid is operated to prevent the forward one-way clutch from idling and the engine brake is operated in the same manner as conventionally.

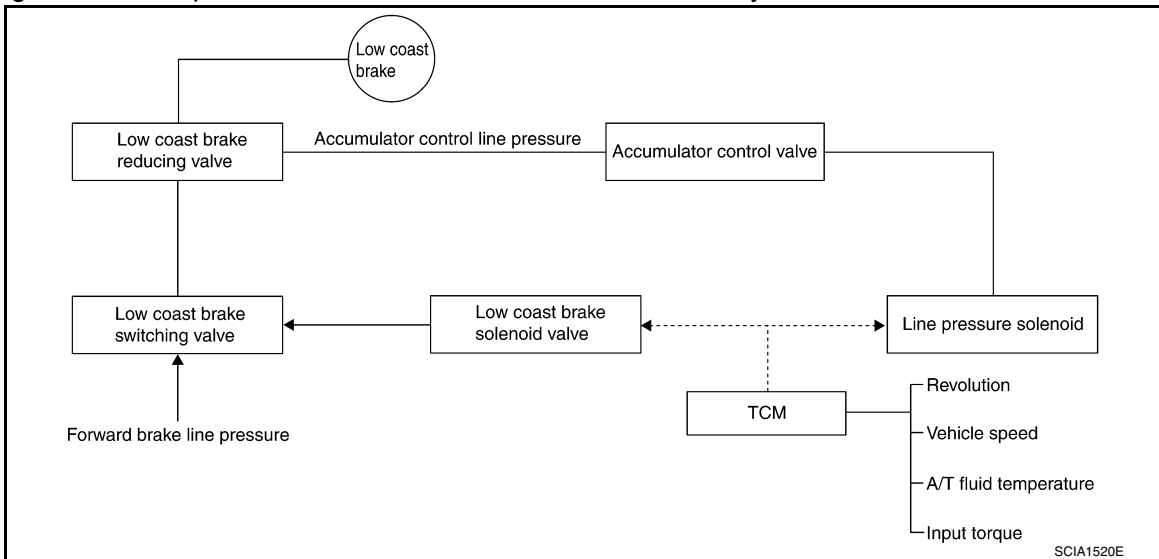

- The operation of the low coast brake solenoid switches the low coast brake switching valve and controls the coupling and releasing of the low coast brake. The low coast brake reducing valve controls the low coast brake coupling force.

## Control Valve

INFOID:000000009885691

### FUNCTION OF CONTROL VALVE

Name	Function
Torque converter regulator valve	In order to prevent the pressure supplied to the torque converter from being excessive, the line pressure is adjusted to the optimum pressure (torque converter operating pressure).
Pressure regulator valve Pressure regulator plug Pressure regulator sleeve	Adjusts the oil discharged from the oil pump to the optimum pressure (line pressure) for the driving state.

# A/T CONTROL SYSTEM

## < SYSTEM DESCRIPTION >

Name	Function
Front brake control valve	When the front brake is coupled, adjusts the line pressure to the optimum pressure (front brake pressure) and supplies it to the front brake. (In 1GR, 2GR, 3GR, and 5GR, adjusts the clutch pressure.)
Accumulator control valve	Adjusts the pressure (accumulator control pressure) acting on the accumulator piston and low coast reducing valve to the pressure appropriate to the driving state.
Pilot valve A	Adjusts the line pressure and produces the constant pressure (pilot pressure) required for line pressure control, shift change control, and lock-up control.
Pilot valve B	Adjusts the line pressure and produces the constant pressure (pilot pressure) required for shift change control.
Low coast brake switching valve	During engine braking, supplies the line pressure to the low coast brake reducing valve.
Low coast brake reducing valve	When the low coast brake is coupled, adjusts the line pressure to the optimum pressure (low coast brake pressure) and supplies it to the low coast brake.
N-R accumulator	Produces the stabilizing pressure for when N-R is selected.
Direct clutch piston switching valve	Operates in 4GR and switches the direct clutch coupling capacity.
High and low reverse clutch control valve	When the high and low reverse clutch is coupled, adjusts the line pressure to the optimum pressure (high and low reverse clutch pressure) and supplies it to the high and low reverse clutch. (In 1GR, 3GR, 4GR and 5GR, adjusts the clutch pressure.)
Input clutch control valve	When the input clutch is coupled, adjusts the line pressure to the optimum pressure (input clutch pressure) and supplies it to the input clutch. (In 4GR and 5GR, adjusts the clutch pressure.)
Direct clutch control valve	When the direct clutch is coupled, adjusts the line pressure to the optimum pressure (direct clutch pressure) and supplies it to the direct clutch. (In 2GR, 3GR, and 4GR, adjusts the clutch pressure.)
TCC control valve TCC control plug TCC control sleeve	Switches the lock-up to operating or released. Also, by performing the lock-up operation transiently, lock-up smoothly.
Torque converter lubrication valve	Operates during lock-up to switch the torque converter, cooling, and lubrication system oil path.
Cool bypass valve	Allows excess oil to bypass cooler circuit without being fed into it.
Line pressure relief valve	Discharges excess oil from line pressure circuit.
N-D accumulator	Produces the stabilizing pressure for when N-D is selected.
Manual valve	Sends line pressure to each circuit according to the select position. The circuits to which the line pressure is not sent drain.

## FUNCTION OF PRESSURE SWITCH

Name	Function
Pressure switch 2 (LC/B)	Detects any malfunction in the low coast brake hydraulic pressure. When it detects any malfunction, it puts the system into fail-safe mode.

# A/T CONTROL SYSTEM

< SYSTEM DESCRIPTION >

## Component Parts Location

INFOID:00000009885692

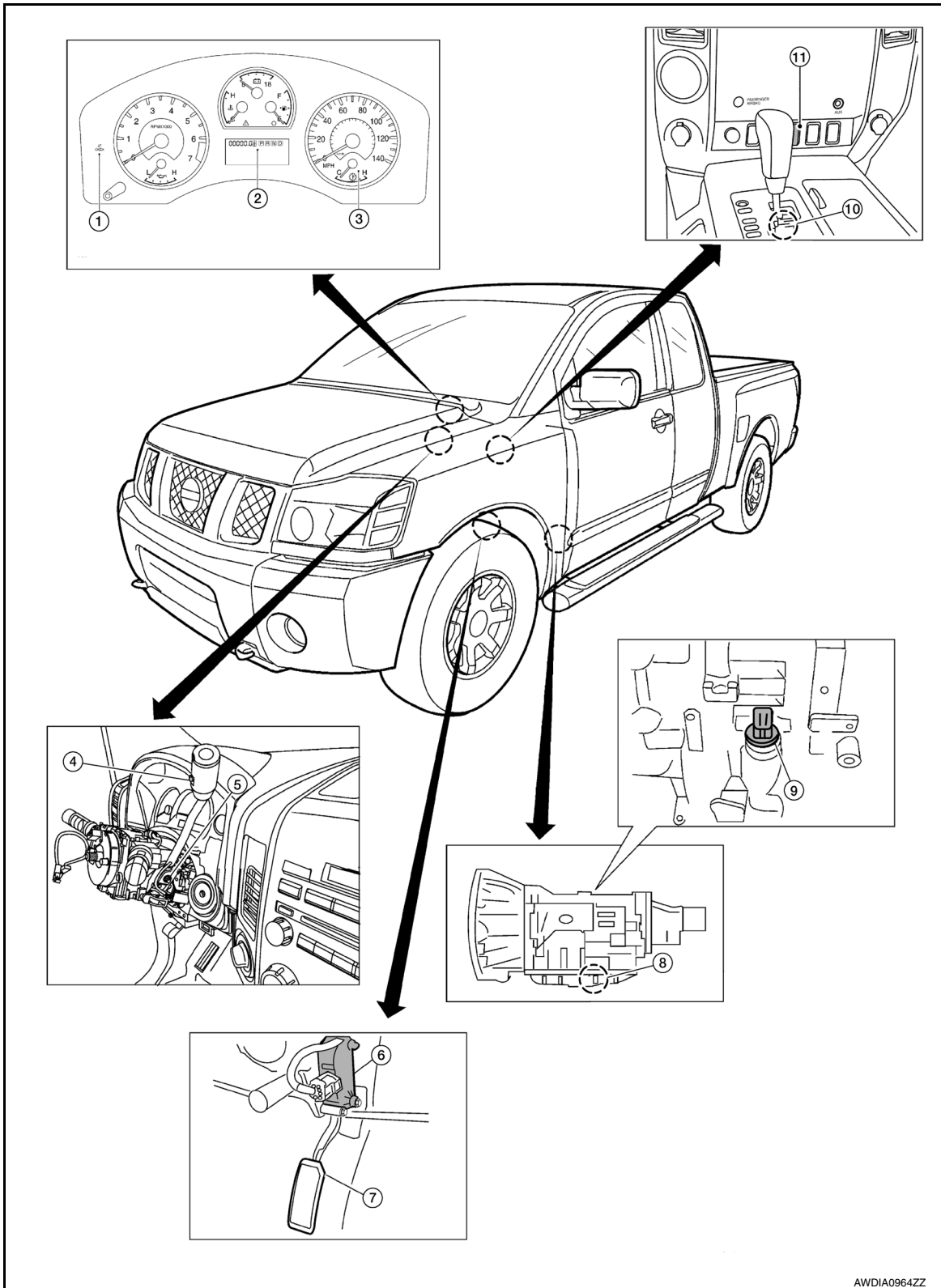

- |  |                                      |  |
|--|--------------------------------------|--|
| 1. AT CHECK indicator lamp                     | 2. A/T position indicator            | 3. A/T oil temp gauge (with trailer tow) |
| 4. Manual mode switch (column shift)           | 5. A/T shift selector (column shift) | 6. Accelerator pedal position sensor     |
| 7. Accelerator pedal                           | 8. Control valve with TCM*1          | 9. A/T assembly harness connector        |
| 10. 1st position switch<br>4th position switch | 11. Tow mode switch                  |  |



# A/T CONTROL SYSTEM

## < SYSTEM DESCRIPTION >

---

\*1: The following components are included in the control valve with TCM.

- TCM (transmission control module)
- Input speed sensor 1
- Input speed sensor 2
- Output speed sensor
- A/T fluid temperature sensor
- Transmission range switch
- Line pressure solenoid valve
- Torque converter clutch solenoid valve
- Direct clutch solenoid valve
- High and low reverse clutch solenoid valve
- Input clutch solenoid valve
- Front brake solenoid valve
- Low coast brake solenoid valve

A

B

C

**TM**

E

F

G

H

I

J

K

L

M

N

O

P

# A/T SHIFT LOCK SYSTEM

< SYSTEM DESCRIPTION >

## A/T SHIFT LOCK SYSTEM

### System Description

INFOID:000000009885693

#### FLOOR SHIFT MODELS

- The selector lever cannot be shifted from “P” (Park) unless the brake pedal is applied and the ignition switch is turned to the “ON” position.
- The ignition switch cannot be returned to the “OFF” position and the key removed unless the selector lever is placed in “P” (Park).
- The shift lock mechanism is controlled by the ON-OFF operation of the shift lock solenoid.
- The key switch and key lock solenoid lock mechanism are controlled by the ON-OFF operation of the key lock solenoid and the operation of the rotator and slider located inside the key cylinder.

#### COLUMN SHIFT MODELS

- The selector lever cannot be shifted from “P” (Park) unless the brake pedal is applied and the ignition switch is turned to the “ON” position.
- The ignition switch cannot be returned to the “OFF” position and the key removed unless the selector lever is placed in “P” (Park).
- The shift lock mechanism is controlled by the ON-OFF operation of the shift lock solenoid.

### Component Parts Location

INFOID:000000009885694

#### FLOOR SHIFT MODELS

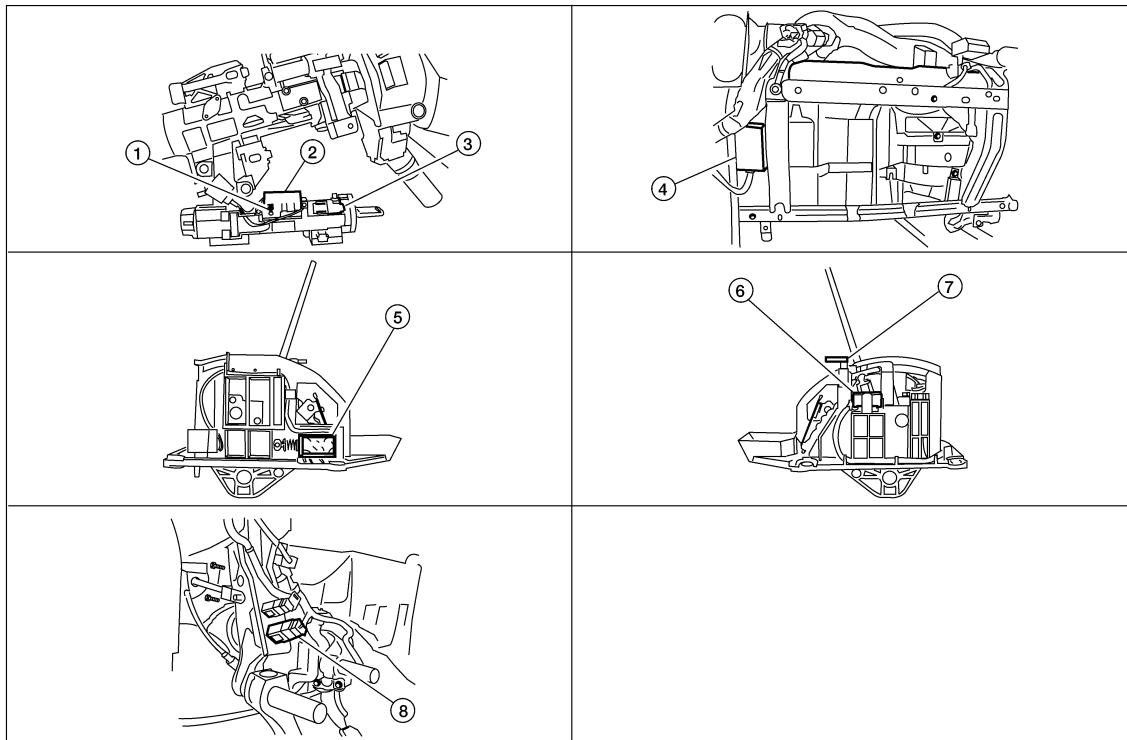

AWDIA0780ZZ

- |  |                        |                         |
|--|------------------------|-------------------------|
| 1. Emergency lever                                       | 2. Key lock solenoid   | 3. Key switch           |
| 4. Shift lock control unit (view with glove box removed) | 5. Shift lock solenoid | 6. Park position switch |
| 7. Shift lock release                                    | 8. Stop lamp switch    |                         |

#### COLUMN SHIFT MODELS

# A/T SHIFT LOCK SYSTEM

## < SYSTEM DESCRIPTION >

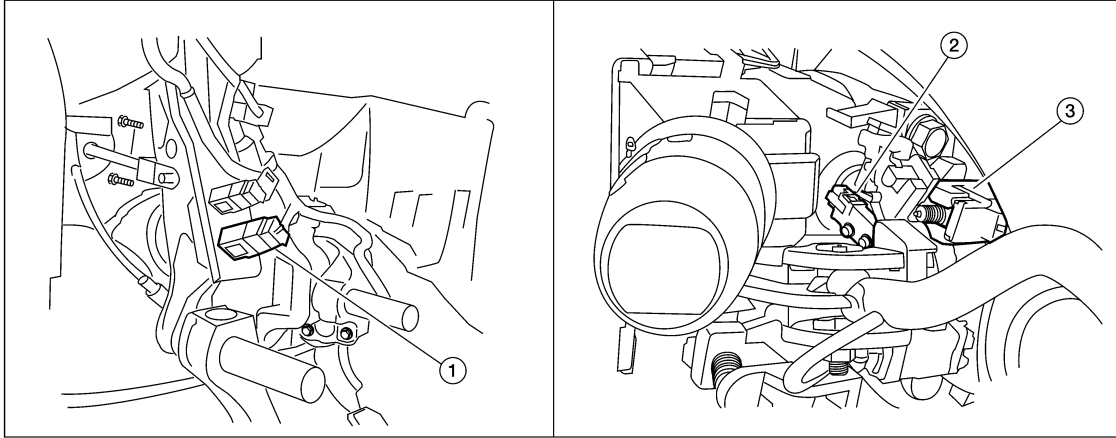

ALDIA0213ZZ

1. Stop lamp switch

2. Park position switch

3. Shift lock solenoid

A

B

C

TM

E

F

G

H

I

J

K

L

M

N

O

P

# ON BOARD DIAGNOSTIC (OBD) SYSTEM

< SYSTEM DESCRIPTION >

## ON BOARD DIAGNOSTIC (OBD) SYSTEM

### Introduction

INFOID:000000009885695

The A/T system has two self-diagnostic systems.

The first is the emission-related on board diagnostic system (OBD-II) performed by the TCM in combination with the ECM. The malfunction is indicated by the MIL (malfunction indicator lamp) and is stored as a DTC in the ECM memory but not the TCM memory.

The second is the TCM original self-diagnosis indicated by the A/T CHECK indicator lamp. The malfunction is stored in the TCM memory. The detected items are overlapped with OBD-II self-diagnostic items. For detail, refer to [TM-38. "CONSULT Function \(TRANSMISSION\)".](#)

### OBD-II Function for A/T System

INFOID:000000009885696

The ECM provides emission-related on board diagnostic (OBD-II) functions for the A/T system. One function is to receive a signal from the TCM used with OBD-related parts of the A/T system. The signal is sent to the ECM when a malfunction occurs in the corresponding OBD-related part. The other function is to indicate a diagnostic result by means of the MIL (malfunction indicator lamp) on the instrument panel. Sensors, switches and solenoid valves are used as sensing elements.

The MIL automatically illuminates in One or Two Trip Detection Logic when a malfunction is sensed in relation to A/T system parts.

### One or Two Trip Detection Logic of OBD-II

INFOID:000000009885697

#### ONE TRIP DETECTION LOGIC

If a malfunction is sensed during the first test drive, the MIL will illuminate and the malfunction will be stored in the ECM memory as a DTC. The TCM is not provided with such a memory function.

#### TWO TRIP DETECTION LOGIC

When a malfunction is sensed during the first test drive, it is stored in the ECM memory as a 1st trip DTC (diagnostic trouble code) or 1st trip freeze frame data. At this point, the MIL will not illuminate. — 1st Trip

If the same malfunction as that experienced during the first test drive is sensed during the second test drive, the MIL will illuminate. — 2nd Trip



The "Trip" in the "One or Two Trip Detection Logic" means a driving mode in which self-diagnosis is performed during vehicle operation.

### OBD-II Diagnostic Trouble Code (DTC)

INFOID:000000009885698

#### HOW TO READ DTC AND 1ST TRIP DTC

DTC and 1st trip DTC can be read by the following methods.

( with **CONSULT** or ( **GST**) CONSULT or GST (Generic Scan Tool) Examples: P0705, P0720 etc.

These DTC are prescribed by SAE J2012.

(CONSULT also displays the malfunctioning component or system.)

- **1st trip DTC No. is the same as DTC No.**
  - **Output of the diagnostic trouble code indicates that the indicated circuit has a malfunction. However, in case of the Mode II and GST, they do not indicate whether the malfunction is still occurring or occurred in the past and returned to normal.**
- CONSULT can identify them as shown below, therefore, CONSULT (if available) is recommended.**

#### Freeze Frame Data and 1st Trip Freeze Frame Data

The ECM has a memory function, which stores the driving condition such as fuel system status, calculated load value, engine coolant temperature, short term fuel trim, long term fuel trim, engine speed and vehicle speed at the moment the ECM detects a malfunction.

Data which are stored in the ECM memory, along with the 1st trip DTC, are called 1st trip freeze frame data, and the data, stored together with the DTC data, are called freeze frame data and displayed on CONSULT or GST. The 1st trip freeze frame data can only be displayed on the CONSULT screen, not on the GST. For detail, refer to [TM-36](#).

Only one set of freeze frame data (either 1st trip freeze frame data or freeze frame data) can be stored in the ECM. 1st trip freeze frame data is stored in the ECM memory along with the 1st trip DTC. There is no priority for 1st trip freeze frame data and it is updated each time a different 1st trip DTC is detected. However, once freeze frame data (2nd trip detection/MIL on) is stored in the ECM memory, 1st trip freeze frame data is no

# ON BOARD DIAGNOSTIC (OBD) SYSTEM

## < SYSTEM DESCRIPTION >

longer stored. Remember, only one set of freeze frame data can be stored in the ECM. The ECM has the following priorities to update the data.

Priority	Items	
1	Freeze frame data	Misfire — DTC: P0300 - P0306 Fuel Injection System Function — DTC: P0171, P0172, P0174, P0175
2		Except the above items (Includes A/T related items)
3	1st trip freeze frame data	

Both 1st trip freeze frame data and freeze frame data (along with the DTC) are cleared when the ECM memory is erased.

### HOW TO ERASE DTC

The diagnostic trouble code can be erased by CONSULT, GST or ECM DIAGNOSTIC TEST MODE as described following.

- **If the battery cable is disconnected, the diagnostic trouble code will be lost within 24 hours.**
- **When you erase the DTC, using CONSULT or GST is easier and quicker than switching the mode selector on the ECM.**

The following emission-related diagnostic information is cleared from the ECM memory when erasing DTC related to OBD-II. For details, refer to [EC-46. "On Board Diagnosis Function"](#).

- **Diagnostic trouble codes (DTC)**
- **1st trip diagnostic trouble codes (1st trip DTC)**
- **Freeze frame data**
- **1st trip freeze frame data**
- **System readiness test (SRT) codes**
- **Test values**

#### HOW TO ERASE DTC (WITH CONSULT)

1. The emission related diagnostic information in the TCM and ECM can be erased by selectioning "ALL ERASE" in the "Description" of "FINAL CHECK" mode with CONSULT.

#### HOW TO ERASE DTC (WITH GST)

1. If the ignition switch stays "ON" after repair work, be sure to turn ignition switch "OFF" once. Wait at least 10 seconds and then turn it "ON" (engine stopped) again.
2. Select Mode 4 with the Generic Scan Tool (GST). For details refer to [EC-37. "GST \(Generic Scan Tool\)"](#).

#### HOW TO ERASE DTC (NO TOOLS)

1. Disconnect battery for 24 hours.
2. Reconnect battery.

## Malfunction Indicator Lamp (MIL)

INFOID:000000009885699

### DESCRIPTION

The MIL is located on the instrument panel.

1. The MIL will light up when the ignition switch is turned "ON" without the engine running. This is a bulb check.
- If the MIL does not light up, refer to [EC-111. "Trouble Diagnosis Introduction"](#).
2. When the engine is started, the MIL should go off. If the MIL remains on, the on board diagnostic system has detected an engine system malfunction.

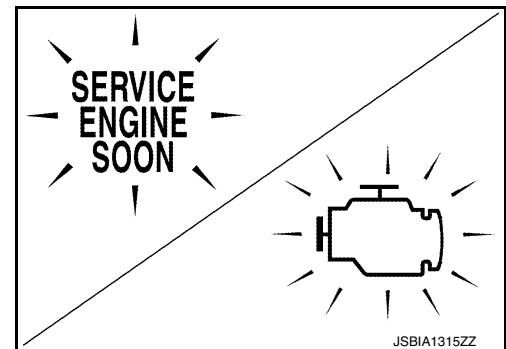

# DIAGNOSIS SYSTEM (TCM)

< SYSTEM DESCRIPTION >

## DIAGNOSIS SYSTEM (TCM)

### CONSULT Function (TRANSMISSION)

INFOID:000000009885700

CONSULT can display each diagnostic item using the diagnostic test modes shown following.

TCM diagnostic mode	Description
Self Diagnostic Result	Retrieve DTC from ECU and display diagnostic items.
Data Monitor	Monitor the input/output signal of the control unit in real time.
CAN Diagnosis	The condition of CAN communication can be indicated by a topology.
CAN Diagnosis Support Monitor	It monitors the status of CAN communication.
DTC work support	DTC reproduction procedure can be performed speedily and precisely.
ECU Identification	Display the ECU identification number (part number etc.) of the selected system.

### SELF-DIAGNOSTIC RESULT MODE

#### Display Items List

X: Applicable, —: Not applicable

Items (CONSULT screen terms)	Malfunction is detected when...	TCM self-diagnosis	OBD (DTC)	Reference page
		"TRANSMISSION" with CONSULT	MIL indicator lamp*1, "ENGINE" with CONSULT or GST	
CAN COMM CIRCUIT	<ul style="list-style-type: none"> <li>When a malfunction is detected in CAN communications</li> </ul>	U1000	U1000	<a href="#">TM-48</a>
STARTER RELAY	<ul style="list-style-type: none"> <li>If this signal is ON other than in P or N position, this is judged to be a malfunction. (And if it is OFF in P or N position, this too is judged to be a malfunction.)</li> </ul>	P0615	—	<a href="#">TM-49</a>
TRANSMISSION CONT	<ul style="list-style-type: none"> <li>TCM is malfunctioning.</li> </ul>	P0700	P0700	<a href="#">TM-52</a>
T/M RANGE SWITCH A	<ul style="list-style-type: none"> <li>Transmission range switch 1-4 signals input with impossible pattern</li> <li>"P" position is detected from N position without any other position being detected in between.</li> </ul>	P0705	P0705	<a href="#">TM-53</a>
INPUT SPEED SENSOR A	<ul style="list-style-type: none"> <li>TCM does not receive the proper voltage signal from the sensor.</li> <li>TCM detects an irregularity only at position of 4GR for input speed sensor 2.</li> </ul>	P0717	P0717	<a href="#">TM-56</a>
OUTPUT SPEED SENSOR	<ul style="list-style-type: none"> <li>Signal from output speed sensor not input due to cut line or the like</li> <li>Unexpected signal input during running</li> <li>After ignition switch is turned ON, irregular vehicle speed signal input from combination meter before the vehicle starts moving</li> </ul>	P0720	P0720	<a href="#">TM-59</a>
ENGINE SPEED	<ul style="list-style-type: none"> <li>TCM does not receive the CAN communication signal from the ECM.</li> </ul>	P0725	—	<a href="#">TM-61</a>
1GR INCORRECT RATIO	<ul style="list-style-type: none"> <li>A/T cannot shift to 1GR</li> </ul>	P0731	P0731	<a href="#">TM-64</a>
2GR INCORRECT RATIO	<ul style="list-style-type: none"> <li>A/T cannot shift to 2GR</li> </ul>	P0732	P0732	<a href="#">TM-66</a>
3GR INCORRECT RATIO	<ul style="list-style-type: none"> <li>A/T cannot shift to 3GR</li> </ul>	P0733	P0733	<a href="#">TM-68</a>

# DIAGNOSIS SYSTEM (TCM)

## < SYSTEM DESCRIPTION >

Items (CONSULT screen terms)	Malfunction is detected when...	TCM self-diagnosis	OBD (DTC)	Reference page	
		"TRANSMISSION" with CONSULT	MIL indicator lamp*1, "ENGINE" with CONSULT or GST		
4GR INCORRECT RATIO	<ul style="list-style-type: none"> <li>A/T cannot shift to 4GR</li> </ul>	P0734	P0734	<a href="#">TM-70</a>	A
5GR INCORRECT RATIO	<ul style="list-style-type: none"> <li>A/T cannot shift to 5GR</li> </ul>	P0735	P0735	<a href="#">TM-72</a>	B
TORQUE CONVERTER	<ul style="list-style-type: none"> <li>Normal voltage not applied to solenoid due to cut line, short, or the like</li> </ul>	P0740	P0740	<a href="#">TM-73</a>	C
TORQUE CONVERTER	<ul style="list-style-type: none"> <li>A/T cannot perform lock-up even if electrical circuit is good.</li> <li>TCM detects as irregular by comparing difference value with slip rotation.</li> </ul>	P0744	P0744*2	<a href="#">TM-75</a>	TM
PC SOLENOID A	<ul style="list-style-type: none"> <li>Normal voltage not applied to solenoid due to cut line, short, or the like</li> <li>TCM detects as irregular by comparing target value with monitor value.</li> </ul>	P0745	P0745	<a href="#">TM-77</a>	E
TP SENSOR	<ul style="list-style-type: none"> <li>TCM does not receive the proper accelerator pedal position signals (input by CAN communication) from ECM.</li> </ul>	P1705	—	<a href="#">TM-79</a>	F
TRANS FLUID TEMP SEN	<ul style="list-style-type: none"> <li>During running, the ATF temperature sensor signal voltage is excessively high or low</li> <li>A/T fluid temperature does not rise to the specified temperature after driving for a certain period of time.</li> <li>There is a certain temperature difference between A/T fluid and engine coolant.</li> </ul>	P1710	P0710	<a href="#">TM-82</a>	G
VEHICLE SPEED SIGNAL	<ul style="list-style-type: none"> <li>Vehicle speed signal (CAN communication) from combination meter not input due to cut line or the like</li> <li>Unexpected signal input during running</li> </ul>	P1721	—	<a href="#">TM-84</a>	H
INTERLOCK	<ul style="list-style-type: none"> <li>Except during shift change, the gear position and ATF pressure switch states are monitored and comparative judgment made.</li> </ul>	P1730	P1730	<a href="#">TM-86</a>	I
1GR E/BRAKING	<ul style="list-style-type: none"> <li>Each ATF pressure switch and solenoid current is monitored and if a pattern is detected having engine braking 1GR other than in the "1" position, a malfunction is detected.</li> </ul>	P1731	—	<a href="#">TM-88</a>	J
INPUT CLUTCH SOL	<ul style="list-style-type: none"> <li>Normal voltage not applied to solenoid due to functional malfunction, cut line, short, or the like</li> <li>TCM detects as irregular by comparing target value with monitor value.</li> </ul>	P1752	P1752	<a href="#">TM-90</a>	K
FR BRAKE SOLENOID	<ul style="list-style-type: none"> <li>Normal voltage not applied to solenoid due to functional malfunction, cut line, short, or the like</li> <li>TCM detects as irregular by comparing target value with monitor value.</li> </ul>	P1757	P1757	<a href="#">TM-92</a>	L
DRCT CLUTCH SOL	<ul style="list-style-type: none"> <li>Normal voltage not applied to solenoid due to cut line, short, or the like</li> <li>TCM detects as irregular by comparing target value with monitor value.</li> </ul>	P1762	P1762	<a href="#">TM-94</a>	M
HLR CLUTCH SOLENOID	<ul style="list-style-type: none"> <li>Normal voltage not applied to solenoid due to functional malfunction, cut line, short, or the like</li> <li>TCM detects as irregular by comparing target value with monitor value.</li> </ul>	P1767	P1767	<a href="#">TM-96</a>	N
L C BRAKE SOLENOID	<ul style="list-style-type: none"> <li>Normal voltage not applied to solenoid due to functional malfunction, cut line, short, or the like</li> </ul>	P1772	P1772	<a href="#">TM-98</a>	O

# DIAGNOSIS SYSTEM (TCM)

## < SYSTEM DESCRIPTION >

Items (CONSULT screen terms)	Malfunction is detected when...	TCM self-diagnosis	OBD (DTC)	Reference page
		"TRANSMISSION" with CONSULT	MIL indicator lamp*1, "ENGINE" with CONSULT or GST	
L C BRAKE SOLENOID	<ul style="list-style-type: none"> <li>TCM detects an improper voltage drop when it tries to operate the solenoid valve.</li> <li>Condition of ATF pressure switch 2 is different from monitor value, and relation between gear position and actual gear ratio is irregular.</li> </ul>	P1774	P1774*2	<a href="#">TM-101</a>
M-MODE SWITCH *3	<ul style="list-style-type: none"> <li>When an impossible pattern of switch signals is detected, a malfunction is detected.</li> </ul>	P1815	—	<a href="#">TM-102</a>
NO DTC IS DETECTED FURTHER TESTING MAY BE REQUIRED	<ul style="list-style-type: none"> <li>No NG item has been detected.</li> </ul>	X	X	

\*1: Refer to [EC-46, "DIAGNOSIS DESCRIPTION : Malfunction Indicator Lamp \(MIL\)"](#).

\*2: These malfunctions cannot be displayed MIL if another malfunction is assigned to MIL.

\*3: Column shift models only.

## DATA MONITOR MODE

### Display Items List

X: Standard, —: Not applicable

Monitored item (Unit)	Monitor Item Selection			Remarks
	ECU INPUT SIGNALS	MAIN SIGNALS	SELECTION FROM MENU	
VHCL/S SE-A/T (km/h or mph)	X	X	X	Output speed sensor
VHCL/S SE-MTR (km/h or mph)	X	—	X	
ACCELE POSI (0.0/8)	X	—	X	Accelerator pedal position signal
THROTTLE POSI (0.0/8)	X	X	X	Degree of opening for accelerator recognized by the TCM For fail-safe operation, the specific value used for control is displayed.
CLSD THL POS (ON-OFF display)	X	—	X	Signal input with CAN communications
W/O THL POS (ON-OFF display)	X	—	X	
BRAKESW (ON-OFF display)	X	—	X	Stop lamp switch
GEAR	—	X	X	Gear position recognized by the TCM updated after gear-shifting
ENGINE SPEED (rpm)	X	X	X	
INPUT SPEED (rpm)	X	X	X	
OUTPUT REV (rpm)	X	X	X	
GEAR RATIO	—	X	X	
TC SLIP SPEED (rpm)	—	X	X	Difference between engine speed and torque converter input shaft speed
F SUN GR REV (rpm)	—	—	X	
F CARR GR REV (rpm)	—	—	X	
ATF TEMP SE 1 (V)	X	—	X	
ATF TEMP 1 (°C or °F)	—	X	X	
ATF TEMP 2 (°C or °F)	—	X	X	
BATTERY VOLT (V)	X	—	X	



# DIAGNOSIS SYSTEM (TCM)

## < SYSTEM DESCRIPTION >

Monitored item (Unit)	Monitor Item Selection			Remarks
	ECU INPUT SIGNALS	MAIN SIGNALS	SELECTION FROM MENU	
ATF PRES SW 1 (ON-OFF display)	X	X	X	Not mounted but displayed.
ATF PRES SW 2 (ON-OFF display)	X	X	X	(for LC/B solenoid)
ATF PRES SW 3 (ON-OFF display)	X	X	X	Not mounted but displayed.
ATF PRES SW 5 (ON-OFF display)	X	X	X	
ATF PRES SW 6 (ON-OFF display)	X	X	X	
RANGE SW 1 (ON-OFF display)	X	—	X	
RANGE SW 2 (ON-OFF display)	X	—	X	
RANGE SW 3 (ON-OFF display)	X	—	X	
RANGE SW 4 (ON-OFF display)	X	—	X	
SLCT LVR POSI	—	X	X	Selector lever position is recognized by the TCM. For fail-safe operation, the specific value used for control is displayed.
1 POSITION SW (ON-OFF display)	X	—	X	1st position switch
OD CONT SW (ON-OFF display)	X	—	X	4th position switch
POWERSHIFT SW (ON-OFF display)	X	—	X	Not mounted but displayed.
HOLD SW (ON-OFF display)	X	—	X	
DS RANGE (ON-OFF display)	X	—	X	
MANU MODE SW (ON-OFF display)	X	—	X	
NON M-MODE SW (ON-OFF display)	X	—	X	
UP SW LEVER (ON-OFF display)	X	—	X	
DOWN SW LEVER (ON-OFF display)	X	—	X	
SFT UP ST SW (ON-OFF display)	X	—	X	Not mounted but displayed.
SFT DWN ST SW (ON-OFF display)	X	—	X	
ASCD-OD CUT (ON-OFF display)	X	—	X	
ASCD-CRUISE (ON-OFF display)	X	—	X	
ABS SIGNAL (ON-OFF display)	X	—	X	
ACC OD CUT (ON-OFF display)	X	—	X	Not mounted but displayed.
ACC SIGNAL (ON-OFF display)	X	—	X	
TCS GR/P KEEP (ON-OFF display)	X	—	X	
TCS SIGNAL 2 (ON-OFF display)	X	—	X	
TCS SIGNAL 1 (ON-OFF display)	X	—	X	
TCC SOLENOID (A)	—	X	X	
LINE PRES SOL (A)	—	X	X	
I/C SOLENOID (A)	—	X	X	
FR/B SOLENOID (A)	—	X	X	
D/C SOLENOID (A)	—	X	X	
HLR/C SOL (A)	—	X	X	
ON OFF SOL (ON-OFF display)	—	—	X	LC/B solenoid
TCC SOL MON (A)	—	—	X	
L/P SOL MON (A)	—	—	X	
I/C SOL MON (A)	—	—	X	
FR/B SOL MON (A)	—	—	X	

# DIAGNOSIS SYSTEM (TCM)

## < SYSTEM DESCRIPTION >

Monitored item (Unit)	Monitor Item Selection			Remarks
	ECU INPUT SIGNALS	MAIN SIGNALS	SELECTION FROM MENU	
D/C SOL MON (A)	—	—	X	
HLR/C SOL MON (A)	—	—	X	
ONOFF SOL MON (ON-OFF display)	—	—	X	LC/B solenoid
P POSI IND (ON-OFF display)	—	—	X	
R POSI IND (ON-OFF display)	—	—	X	
N POSI IND (ON-OFF display)	—	—	X	
D POSI IND (ON-OFF display)	—	—	X	
4TH POSI IND (ON-OFF display)	—	—	X	
3RD POSI IND (ON-OFF display)	—	—	X	
2ND POSI IND (ON-OFF display)	—	—	X	
1ST POSI IND (ON-OFF display)	—	—	X	
MANU MODE IND (ON-OFF display)	—	—	X	
POWER M LAMP (ON-OFF display)	—	—	X	Not mounted but displayed.
F-SAFE IND/L (ON-OFF display)	—	—	X	
ATF WARN LAMP (ON-OFF display)	—	—	X	
BACK-UP LAMP (ON-OFF display)	—	—	X	
STARTER RELAY (ON-OFF display)	—	—	X	
RANGE SW 3M (ON-OFF display)	—	—	X	
C/V CLB ID1	—	—	X	
C/V CLB ID2	—	—	X	
C/V CLB ID3	—	—	X	
UNIT CLB ID1	—	—	X	
UNIT CLB ID2	—	—	X	
UNIT CLB ID3	—	—	X	
TRGT GR RATIO	—	—	X	
TRGT PRES TCC (kPa, kg/cm <sup>2</sup> or psi)	—	—	X	
TRGT PRES L/P (kPa, kg/cm <sup>2</sup> or psi)	—	—	X	
TRGT PRES I/C (kPa, kg/cm <sup>2</sup> or psi)	—	—	X	
TRGT PRE FR/B (kPa, kg/cm <sup>2</sup> or psi)	—	—	X	
TRGT PRES D/C (kPa, kg/cm <sup>2</sup> or psi)	—	—	X	
TRG PRE HLR/C (kPa, kg/cm <sup>2</sup> or psi)	—	—	X	
SHIFT PATTERN	—	—	X	
DRV CST JUDGE	—	—	X	
START RLY MON	—	—	X	
NEXT GR POSI	—	—	X	
SHIFT MODE	—	—	X	
MANU GR POSI	—	—	X	
VEHICLE SPEED (km/h or mph)	—	X	X	Vehicle speed recognized by the TCM.

## DTC WORK SUPPORT

### Display Items List

# DIAGNOSIS SYSTEM (TCM)

## < SYSTEM DESCRIPTION >

DTC work support item	Description	Check item
1ST GR FNCTN P0731	Following items for "1GR incorrect ratio" be confirmed. • Self-diagnosis status (whether the diagnosis is being performed or not) • Self-diagnosis result (OK or NG)	
2ND GR FNCTN P0732	Following items for "2GR incorrect ratio" be confirmed. • Self-diagnosis status (whether the diagnosis is being performed or not) • Self-diagnosis result (OK or NG)	
3RD GR FNCTN P0733	Following items for "3GR incorrect ratio" be confirmed. • Self-diagnosis status (whether the diagnosis is being performed or not) • Self-diagnosis result (OK or NG)	
4TH GR FNCTN P0734	Following items for "4GR incorrect ratio" be confirmed. • Self-diagnosis status (whether the diagnosis is being performed or not) • Self-diagnosis result (OK or NG)	
5TH GR FNCTN P0735	Following items for "5GR incorrect ratio" be confirmed. • Self-diagnosis status (whether the diagnosis is being performed or not) • Self-diagnosis result (OK or NG)	

A  
B  
C  
TM  
E  
F  
G

## Diagnosis Procedure without CONSULT (Floor Shift Models)

INFOID:000000009885701

### OBD-II SELF-DIAGNOSTIC PROCEDURE (NO TOOLS)

Refer to [EC-46. "On Board Diagnosis Function"](#).

### TCM SELF-DIAGNOSTIC PROCEDURE (NO TOOLS)

#### Description

When the ignition switch is switched "ON", the A/T CHECK indicator lamp lights up for 2 seconds. As a method for locating the suspect circuit, when the self-diagnostics start signal is input, the memory for the malfunction location is output and the A/T CHECK indicator lamp flashes to display the corresponding DTC.

#### Diagnostic Procedure

### 1. CHECK A/T CHECK INDICATOR LAMP

1. Start the engine with selector lever in "P" position. Warm engine to normal operating temperature.
2. Turn ignition switch ON and OFF at least twice, then leave it in the OFF position.
3. Wait 10 seconds.
4. Turn ignition switch ON. (Do not start engine.)

Does A/T CHECK indicator lamp come on for about 2 seconds?

YES >> GO TO 2.

NO >> Go to [TM-143. "Symptom Table"](#).

### 2. JUDGMENT PROCEDURE STEP 1

1. Turn ignition switch OFF.
2. Keep pressing shift lock release button.
3. Move selector lever from "P" to "D" position.
4. Release accelerator pedal. (Set the closed throttle position signal "ON".)
5. Depress brake pedal. (Stop lamp switch signal "ON".)
6. Turn ignition switch ON. (Do not start engine.)
7. Wait 3 seconds.
8. Move the selector lever from "D" to "3" position.
9. Release brake pedal. (Stop lamp switch signal "OFF".)
10. Move the selector lever from "3" to "2" position.
11. Depress brake pedal. (Stop lamp switch signal "ON".)
12. Depress accelerator pedal fully and release it.

H  
I  
J  
K  
L  
M  
N  
O  
P

# DIAGNOSIS SYSTEM (TCM)

## < SYSTEM DESCRIPTION >

>> GO TO 3.

### 3. CHECK SELF-DIAGNOSIS CODE

Check A/T CHECK indicator lamp.

Refer to "Judgment Self-diagnosis Code".

If the system does not go into self-diagnostics. Refer to [TM-53, "Diagnosis Procedure"](#), [TM-109, "Diagnosis Procedure"](#), [TM-110, "Diagnosis Procedure"](#).

#### >> DIAGNOSIS END

Judgment Self-diagnosis Code

If there is a malfunction, the lamp lights up for the time corresponding to the suspect circuit.

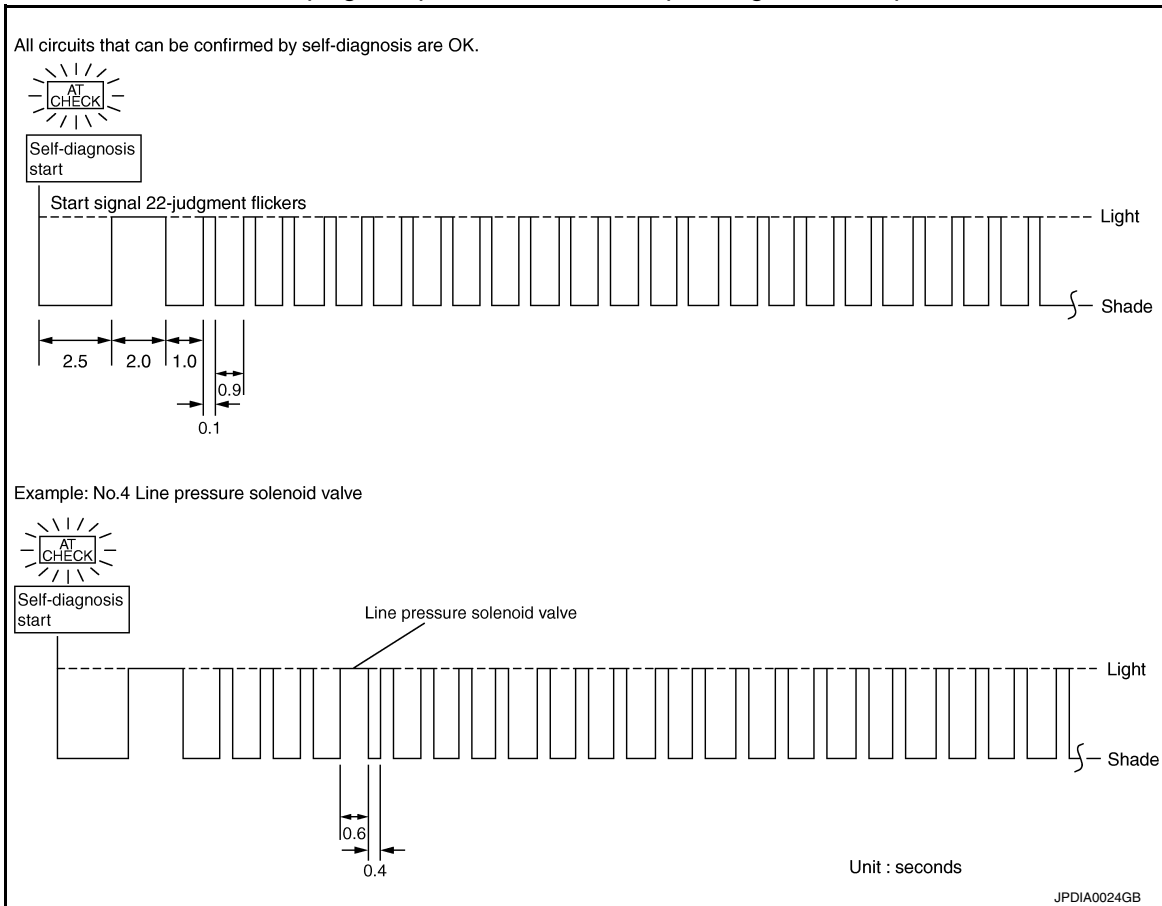

No.	Malfunctioning item	No.	Malfunctioning item
1	Output speed sensor <a href="#">TM-58</a>	12	Interlock <a href="#">TM-86</a>
2	Direct clutch solenoid <a href="#">TM-94</a>	13	1st engine braking <a href="#">TM-88</a>
3	Torque converter <a href="#">TM-73, TM-75</a>	14	Starter relay <a href="#">TM-49</a>
4	Line pressure solenoid <a href="#">TM-77</a>	15	TP sensor <a href="#">TM-79</a>
5	Input clutch solenoid <a href="#">TM-90</a>	16	Engine speed <a href="#">TM-61</a>
6	Front brake solenoid <a href="#">TM-92</a>	17	CAN communication line <a href="#">TM-48</a>
7	Low coast brake solenoid <a href="#">TM-98, TM-100</a>	18	1GR incorrect ratio <a href="#">TM-63</a>
8	High and low reverse clutch solenoid <a href="#">TM-96</a>	19	2GR incorrect ratio <a href="#">TM-65</a>
9	Transmission range switch <a href="#">TM-53</a>	20	3GR incorrect ratio <a href="#">TM-67</a>
10	Transmission fluid temperature sensor <a href="#">TM-81</a>	21	4GR incorrect ratio <a href="#">TM-69</a>
11	Input speed sensor <a href="#">TM-56</a>	22	5GR incorrect ratio <a href="#">TM-71</a>

Erase Self-diagnosis

# DIAGNOSIS SYSTEM (TCM)

## < SYSTEM DESCRIPTION >

- In order to make it easier to find the cause of hard-to-duplicate malfunctions, malfunction information is stored into the control unit as necessary during use by the user. This memory is not erased no matter how many times the ignition switch is turned ON and OFF.
- However, this information is erased by turning ignition switch OFF after executing self-diagnostics or by erasing the memory using the CONSULT.

## Diagnosis Procedure without CONSULT (Column Shift Models)

INFOID:000000009885702

### OBD-II SELF-DIAGNOSTIC PROCEDURE (NO TOOLS)

Refer to [EC-46, "On Board Diagnosis Function"](#).

### TCM SELF-DIAGNOSTIC PROCEDURE (NO TOOLS)

#### Description

When the ignition switch is switched "ON", the A/T CHECK indicator lamp lights up for 2 seconds. As a method for locating the suspect circuit, when the self-diagnostics start signal is input, the memory for the malfunction location is output and the A/T CHECK indicator lamp flashes to display the corresponding DTC.

#### Diagnostic Procedure

### 1. CHECK A/T CHECK INDICATOR LAMP

1. Start the engine with selector lever in "P" position. Warm engine to normal operating temperature.
2. Turn ignition switch ON and OFF at least twice, then leave it in the OFF position.
3. Wait 10 seconds.
4. Turn ignition switch ON. (Do not start engine.)

Does A/T CHECK indicator lamp come on for about 2 seconds?

YES >> GO TO 2.

NO >> Go to [TM-143, "Symptom Table"](#).

### 2. JUDGMENT PROCEDURE STEP 1

1. Turn ignition switch OFF.
2. Keep pressing shift lock release button.
3. Move selector lever from "P" to "D" position.
4. Release accelerator pedal. (Set the closed throttle position signal "ON".)
5. Depress brake pedal. (Stop lamp switch signal "ON".)
6. Turn ignition switch ON. (Do not start engine.)
7. Wait 3 seconds.
8. Move the selector lever from "D" to "M" position.
9. Release brake pedal. (Stop lamp switch signal "OFF".)
10. Move the selector lever from "M" to "D" position.
11. Depress brake pedal. (Stop lamp switch signal "ON".)
12. Depress accelerator pedal fully and release it.

>> GO TO 3.

### 3. CHECK SELF-DIAGNOSIS CODE

Check A/T CHECK indicator lamp.

Refer to "Judgment Self-diagnosis Code".

If the system does not go into self-diagnostics. Refer to [TM-53, "Diagnosis Procedure"](#), [TM-109, "Diagnosis Procedure"](#), [TM-110, "Diagnosis Procedure"](#).

>> **DIAGNOSIS END**

Judgment Self-diagnosis Code

# DIAGNOSIS SYSTEM (TCM)

## < SYSTEM DESCRIPTION >

If there is a malfunction, the lamp lights up for the time corresponding to the suspect circuit.

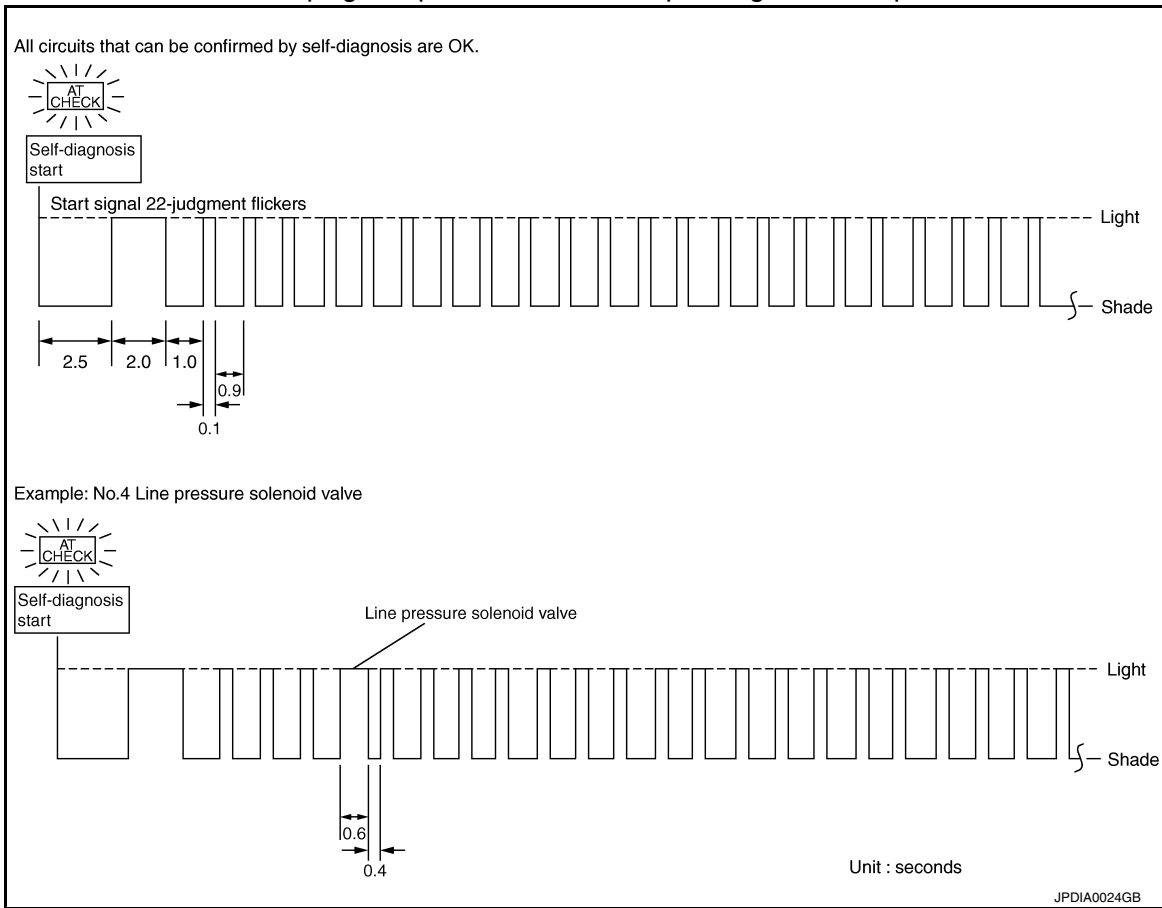

No.	Malfunctioning item	No.	Malfunctioning item
1	Output speed sensor <a href="#">TM-58</a>	12	Interlock <a href="#">TM-86</a>
2	Direct clutch solenoid <a href="#">TM-94</a>	13	1st engine braking <a href="#">TM-88</a>
3	Torque converter <a href="#">TM-73</a> , <a href="#">TM-75</a>	14	Starter relay <a href="#">TM-49</a>
4	Line pressure solenoid <a href="#">TM-77</a>	15	TP sensor <a href="#">TM-79</a>
5	Input clutch solenoid <a href="#">TM-90</a>	16	Engine speed <a href="#">TM-61</a>
6	Front brake solenoid <a href="#">TM-92</a>	17	CAN communication line <a href="#">TM-48</a>
7	Low coast brake solenoid <a href="#">TM-98</a> , <a href="#">TM-100</a>	18	1GR incorrect ratio <a href="#">TM-63</a>
8	High and low reverse clutch solenoid <a href="#">TM-96</a>	19	2GR incorrect ratio <a href="#">TM-65</a>
9	Transmission range switch <a href="#">TM-53</a>	20	3GR incorrect ratio <a href="#">TM-67</a>
10	Transmission fluid temperature sensor <a href="#">TM-81</a>	21	4GR incorrect ratio <a href="#">TM-69</a>
11	Input speed sensor <a href="#">TM-56</a>	22	5GR incorrect ratio <a href="#">TM-71</a>

### Erase Self-diagnosis

- In order to make it easier to find the cause of hard-to-duplicate malfunctions, malfunction information is stored into the control unit as necessary during use by the user. This memory is not erased no matter how many times the ignition switch is turned ON and OFF.
- However, this information is erased by turning ignition switch OFF after executing self-diagnostics or by erasing the memory using the CONSULT.

# U0100 LOST COMMUNICATION (ECM A)

< DTC/CIRCUIT DIAGNOSIS >

## DTC/CIRCUIT DIAGNOSIS

### U0100 LOST COMMUNICATION (ECM A)

#### Description

INFOID:000000009885703

CAN (Controller Area Network) is a serial communication line for real time application. It is an on-vehicle multiplex communication line with high data communication speed and excellent malfunction detection ability. Many electronic control units are equipped onto a vehicle, and each control unit shares information and links with other control units during operation (not independent). In CAN communication, control units are connected with 2 communication lines (CAN H line, CAN L line) allowing a high rate of information transmission with less wiring. Each control unit transmits/receives data but selectively reads required data only.

#### On Board Diagnosis Logic

INFOID:000000009885704

- This is an OBD-II self-diagnostic item.
- Diagnostic trouble code "U0100" with CONSULT is detected when TCM is unable to receive the CAN communications signal from ECM.

#### Possible Cause

INFOID:000000009885705

- ECM
- Harness or connectors  
(CAN communication line is open or shorted.)

#### DTC Confirmation Procedure

INFOID:000000009885706

##### NOTE:

**If "DTC Confirmation Procedure" has been previously performed, always turn ignition switch "OFF" and wait at least 10 seconds before performing the next test.**

After the repair, perform the following procedure to confirm the malfunction is eliminated.

##### WITH CONSULT

1. Turn ignition switch "ON". (Do not start engine.)
2. Select "DATA MONITOR" mode for "TRANSMISSION" with CONSULT.
3. Start engine and wait for at least 6 seconds.
4. If DTC is detected, go to [TM-47, "Diagnosis Procedure"](#).

##### WITH GST

Follow the procedure "WITH CONSULT".

#### Diagnosis Procedure

INFOID:000000009885707

### 1. CHECK CAN COMMUNICATION CIRCUIT

##### With CONSULT

1. Turn ignition switch "ON" and start engine.
2. Select "SELF-DIAG RESULTS" mode for "TRANSMISSION" with CONSULT.

##### Is "U0100" detected?

YES >> Go to LAN section. Refer to [LAN-14, "Trouble Diagnosis Flow Chart"](#).

NO >> **INSPECTION END**

# U1000 CAN COMM CIRCUIT

< DTC/CIRCUIT DIAGNOSIS >

## U1000 CAN COMM CIRCUIT

### Description

INFOID:000000009885708

CAN (Controller Area Network) is a serial communication line for real time application. It is an on-vehicle multiplex communication line with high data communication speed and excellent malfunction detection ability. Many electronic control units are equipped onto a vehicle, and each control unit shares information and links with other control units during operation (not independent). In CAN communication, control units are connected with 2 communication lines (CAN H line, CAN L line) allowing a high rate of information transmission with less wiring. Each control unit transmits/receives data but selectively reads required data only.

### On Board Diagnosis Logic

INFOID:000000009885709

- This is an OBD-II self-diagnostic item.
- Diagnostic trouble code "U1000" with CONSULT or 17th judgment flicker without CONSULT is detected when TCM cannot communicate to other control units.

### Possible Cause

INFOID:000000009885710

Harness or connectors  
(CAN communication line is open or shorted.)

### DTC Confirmation Procedure

INFOID:000000009885711

#### NOTE:

If "DTC Confirmation Procedure" has been previously performed, always turn ignition switch "OFF" and wait at least 10 seconds before performing the next test.

After the repair, perform the following procedure to confirm the malfunction is eliminated.

#### Ⓟ WITH CONSULT

1. Turn ignition switch "ON". (Do not start engine.)
2. Select "DATA MONITOR" mode for "TRANSMISSION" with CONSULT.
3. Start engine and wait for at least 6 seconds.
4. If DTC is detected, go to [TM-48, "Diagnosis Procedure"](#).

#### Ⓟ WITH GST

Follow the procedure "WITH CONSULT".

### Diagnosis Procedure

INFOID:000000009885712

## 1. CHECK CAN COMMUNICATION CIRCUIT

#### Ⓟ With CONSULT

1. Turn ignition switch "ON" and start engine.
2. Select "SELF-DIAG RESULTS" mode for "TRANSMISSION" with CONSULT.

Is "U1000" detected?

- YES >> Go to LAN section. Refer to [LAN-14, "Trouble Diagnosis Flow Chart"](#).  
NO >> **INSPECTION END**



# P0615 STARTER RELAY

< DTC/CIRCUIT DIAGNOSIS >

## P0615 STARTER RELAY

### Description

INFOID:000000009885713

- TCM prohibits cranking other than at “P” or “N” position.

### CONSULT Reference Value in Data Monitor Mode

INFOID:000000009885714

Item name	Condition	Display value
STARTER RELAY	Selector lever in “N”, “P” position.	ON
	Selector lever in other position.	OFF

### On Board Diagnosis Logic

INFOID:000000009885715

- This is not an OBD-II self-diagnostic item.
- Diagnostic trouble code “P0615” with CONSULT is detected when starter relay is switched “ON” other than at “P” or “N” position. (Or when switched “OFF” at “P” or “N” position).

### Possible Cause

INFOID:000000009885716

- Harness or connectors  
(The starter relay and TCM circuit is open or shorted.)
- Starter relay

### DTC Confirmation Procedure

INFOID:000000009885717

#### NOTE:

If “DTC Confirmation Procedure” has been previously performed, always turn ignition switch “OFF” and wait at least 10 seconds before performing the next test.

After the repair, perform the following procedure to confirm the malfunction is eliminated.

#### ④ WITH CONSULT

1. Turn ignition switch “ON”. (Do not start engine.)
2. Select “DATA MONITOR” mode for “TRANSMISSION” with CONSULT.
3. Start engine.
4. Drive vehicle for at least 2 consecutive seconds.
5. If DTC is detected, go to [TM-49. "Diagnosis Procedure"](#).

### Diagnosis Procedure

INFOID:000000009885718

#### 1. CHECK STARTER RELAY

##### ④ With CONSULT

1. Turn ignition switch “ON”. (Do not start engine.)
2. Select “SELECTION FROM MENU” in “DATA MONITOR” mode for “TRANSMISSION” with CONSULT and check monitor “STARTER RELAY” ON/OFF.

Item name	Condition	Display value
STARTER RELAY	Selector lever in “N”, “P” positions.	ON
	Selector lever in other positions.	OFF

##### ⊗ Without CONSULT

1. Turn ignition switch “ON”. (Do not start engine.)

# P0615 STARTER RELAY

## < DTC/CIRCUIT DIAGNOSIS >

2. Check voltage between the IPDM E/R connector and ground.

Item	Connector	Terminal	Shift position	Voltage (Approx.)
Starter re- lay	E122	48	Ground	Battery voltage
			"N" and "P"	0V

### OK or NG

- OK >> GO TO 5.  
NG >> GO TO 2.

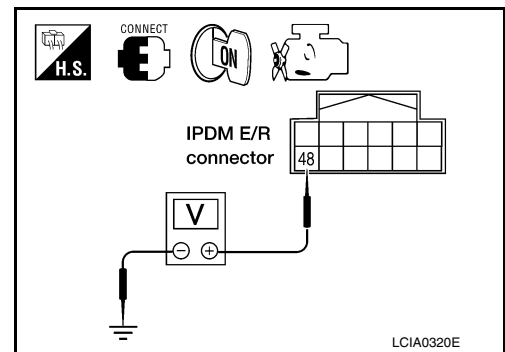

## 2. CHECK HARNESS BETWEEN A/T ASSEMBLY HARNESS CONNECTOR AND IPDM E/R CONECTOR.

1. Turn ignition switch OFF.
2. Disconnect A/T assembly harness connector and IPDM E/R connector.
3. Check continuity between A/T assembly harness connector and IPDM E/R connector.

Item	Connector	Terminal	Continuity
A/T assembly harness con- nector (floor shift)	F9	9	Yes
A/T assembly harness con- nector (column shift)	F17		
IPDM E/R connector	E122	48	

4. If OK, check harness for short to ground and short to power.
5. Reinstall any part removed.

### OK or NG

- OK >> GO TO 3.  
NG >> Repair open circuit or short to ground or short to power in harness or connectors.

## 3. CHECK TERMINAL CORD ASSEMBLY

1. Remove control valve with TCM. Refer to [TM-201, "Control Valve with TCM"](#)
2. Disconnect A/T assembly harness connector and TCM connector.
3. Check continuity between A/T assembly harness connector terminal and TCM connector terminal.

Item	Connector	Terminal	Continuity
A/T assembly har- ness connector (floor shift)	F9	9	Yes
A/T assembly har- ness connector (column shift)	F17		
TCM connector	F502	8	

4. If OK, check harness for short to ground and short to power.
5. Reinstall any part removed.

### OK or NG

- OK >> GO TO 4.  
NG >> Replace open circuit or short to ground and short to power in harness or connectors.

## 4. DETECT MALFUNCTIONING ITEM

Check the following items:

- Starter relay, Refer to [STR-10, "System Description"](#).
- IPDM E/R, Refer to [PCS-18, "Physical Values"](#).

### OK or NG

- OK >> Replace the control valve with TCM. Refer to [TM-201, "Control Valve with TCM"](#).  
NG >> Repair or replace damaged parts.

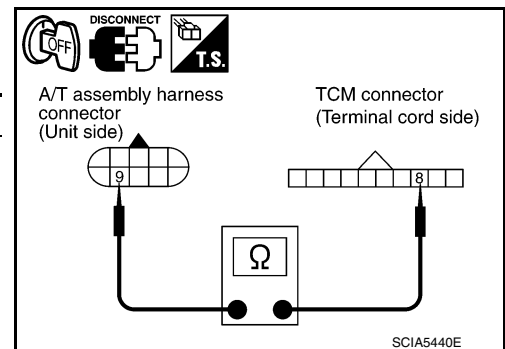
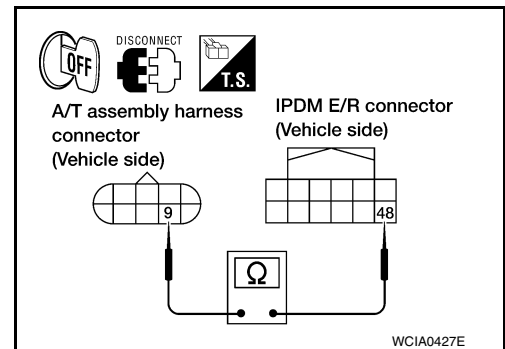

# P0615 STARTER RELAY

< DTC/CIRCUIT DIAGNOSIS >

---

## 5. CHECK DTC

---

Perform "DTC Confirmation Procedure".

- Refer to [TM-49, "DTC Confirmation Procedure"](#).

OK or NG

OK >> **INSPECTION END**

NG >> GO TO 2.

A

B

C

TM

E

F

G

H

I

J

K

L

M

N

O

P

# P0700 TRANSMISSION CONTROL

< DTC/CIRCUIT DIAGNOSIS >

---

## P0700 TRANSMISSION CONTROL

### Description

INFOID:000000009885719

The TCM consists of a microcomputer and connectors for signal input and output and for power supply. The TCM controls the A/T.

### On Board Diagnosis Logic

INFOID:000000009885720

- This is an OBD-II self-diagnostic item.
- Diagnostic trouble code "P0700" with CONSULT is detected when the TCM is malfunctioning.

### Possible Cause

INFOID:000000009885721

TCM.

### DTC Confirmation Procedure

INFOID:000000009885722

#### NOTE:

**If "DTC Confirmation Procedure" has been previously performed, always turn ignition switch "OFF" and wait at least 10 seconds before performing the next test.**

After the repair, perform the following procedure to confirm the malfunction is eliminated.

#### WITH CONSULT

1. Turn ignition switch "ON". (Do not start engine.)
2. Select "DATA MONITOR" mode for "TRANSMISSION" with CONSULT.
3. Start engine.
4. Run engine for at least 2 consecutive seconds at idle speed.
5. If DTC is detected, go to [TM-52. "Diagnosis Procedure"](#).

#### WITH GST

Follow the procedure "With CONSULT".

### Diagnosis Procedure

INFOID:000000009885723

## 1. CHECK DTC

---

#### With CONSULT

1. Turn ignition switch "ON". (Do not start engine.)
2. Select "SELF DIAG RESULTS" mode for "TRANSMISSION" with CONSULT.
3. Touch "ERASE".
4. Turn ignition switch "OFF" and wait at least 10 seconds.
5. Perform DTC Confirmation Procedure, [TM-52. "DTC Confirmation Procedure"](#).

Is the "P0700" displayed again?

- YES >> Replace the control valve with TCM. Refer to [TM-201. "Control Valve with TCM"](#).  
NO >> **INSPECTION END**

# P0705 TRANSMISSION RANGE SWITCH A

< DTC/CIRCUIT DIAGNOSIS >

## P0705 TRANSMISSION RANGE SWITCH A

### Description

INFOID:000000009885724

The transmission range switch detects the selector lever position and sends a signal to the TCM.

### CONSULT Reference Value in Data Monitor Mode

INFOID:000000009885725

Item name	Condition	Display value
SLCTLVR POSI	Selector lever in "N", "P" positions.	N/P
	Selector lever in "R" position.	R
	Selector lever in "D" position.	D
	Selector lever in "4" position.	4
	Selector lever in "3" position.	3
	Selector lever in "2" position.	2
	Selector lever in "1" position.	1

### On Board Diagnosis Logic

INFOID:000000009885726

- This is an OBD-II self-diagnostic item.
- Diagnostic trouble code "P0705" with CONSULT or 9th judgment flicker without CONSULT is detected under the following conditions.
  - When TCM does not receive the correct voltage signal from the transmission range switch 1, 2, 3, 4 based on the gear position.
  - When no other position but "P" position is detected from "N" positions.

### Possible Cause

INFOID:000000009885727

- Harness or connectors  
(The transmission range switch 1, 2, 3, 4 and TCM circuit is open or shorted.)
- Transmission range switch 1, 2, 3, 4

### DTC Confirmation Procedure

INFOID:000000009885728

#### **CAUTION:**

**Always drive vehicle at a safe speed.**

#### **NOTE:**

**If "DTC Confirmation Procedure" has been previously performed, always turn ignition switch "OFF" and wait at least 10 seconds before performing the next test.**

After the repair, perform the following procedure to confirm the malfunction is eliminated.

#### WITH CONSULT

1. Turn ignition switch "ON". (Do not start engine.)
2. Select "DATA MONITOR" mode for "TRANSMISSION" with CONSULT.
3. Start engine.
4. Drive vehicle and maintain the following conditions for at least 2 consecutive seconds.  
**ACCELE POSI: More than 1.0/8**
5. If DTC is detected, go to [TM-53, "Diagnosis Procedure"](#).

#### WITH GST

Follow the procedure "With CONSULT".

### Diagnosis Procedure

INFOID:000000009885729

#### 1. CHECK TRANSMISSION RANGE SW CIRCUIT

##### With CONSULT

1. Turn ignition switch "ON". (Do not start engine.)
2. Select "SELECTION FROM MENU" in "DATA MONITOR" mode for "TRANSMISSION" with CONSULT.

# P0705 TRANSMISSION RANGE SWITCH A

## < DTC/CIRCUIT DIAGNOSIS >

- Check if correct selector lever position (N/P, R or D) is displayed as selector lever is moved into each position.

Item name	Condition	Display value
SLCTLVR POSI	Selector lever in "N", "P" positions.	N/P
	Selector lever in "R" position.	R
	Selector lever in "D" position.	D
	Selector lever in "4" position.	4
	Selector lever in "3" position.	3
	Selector lever in "2" position.	2
	Selector lever in "1" position.	1

### OK or NG

- OK >> GO TO 5.  
 NG >> GO TO 2.

## 2. CHECK TCM POWER SUPPLY AND GROUND CIRCUIT

Perform TCM power supply and ground circuit. Refer to [TM-105, "Diagnosis Procedure"](#).

### OK or NG

- OK >> GO TO 3.  
 NG >> Repair or replace damaged parts.

## 3. DETECT MALFUNCTIONING ITEM

Check the following items:

- A/T assembly harness connector pin terminals for damage or loose connection with harness connector.

### OK or NG

- OK >> GO TO 4.  
 NG >> Repair or replace damaged parts.

## 4. CHECK SUB-HARNESS

- Remove control valve with TCM. Refer to [TM-201, "Control Valve with TCM"](#).
- Disconnect transmission range switch connector and TCM connector.
- Check continuity between transmission range switch connector (A) terminals and TCM connector (B) terminals.

Item	Connector	Terminal	Continuity
Transmission range switch connector	F505	1	Yes
TCM connector	F503	13	
Transmission range switch connector	F505	2	Yes
TCM connector	F503	11	
Transmission range switch connector	F505	3	Yes
TCM connector	F503	12	
Transmission range switch connector	F505	5	Yes
TCM connector	F503	14	

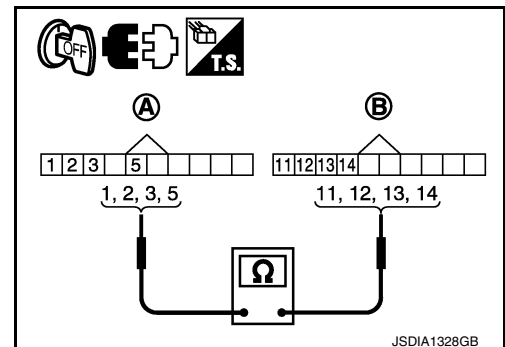

- If OK, check harness for short to ground and short to power.
- Reinstall any part removed.

### OK or NG

- OK >> Replace the control valve with TCM. Refer to [TM-201, "Control Valve with TCM"](#).  
 NG >> Replace open circuit or short to ground and short to power in harness or connectors.

## 5. CHECK DTC

## P0705 TRANSMISSION RANGE SWITCH A

< DTC/CIRCUIT DIAGNOSIS >

---

Perform "DTC Confirmation Procedure".

- Refer to [TM-53, "DTC Confirmation Procedure"](#).

OK or NG

OK >> **INSPECTION END**

NG >> GO TO 2.

A

B

C

TM

E

F

G

H

I

J

K

L

M

N

O

P

# P0717 INPUT SPEED SENSOR A

< DTC/CIRCUIT DIAGNOSIS >

## P0717 INPUT SPEED SENSOR A

### Description

INFOID:000000009885730

The input speed sensor detects input shaft rpm (revolutions per minute). It is located on the input side of the automatic transmission. Monitors revolution of sensor 1 and sensor 2 for non-standard conditions.

### CONSULT Reference Value in Data Monitor Mode

INFOID:000000009885731

Item name	Condition	Display value (rpm)
INPUT SPEED	During driving (lock-up ON)	Approximately matches the engine speed.

### On Board Diagnosis Logic

INFOID:000000009885732

- This is an OBD-II self-diagnostic item.
- Diagnostic trouble code "P0717" with CONSULT or 11th judgment flicker without CONSULT is detected under the following conditions.
  - When TCM does not receive the proper voltage signal from the sensor.
  - When TCM detects an irregularity only at position of 4GR for input speed sensor 2.

### Possible Cause

INFOID:000000009885733

- Harness or connectors  
(The sensor circuit is open or shorted.)
- Input speed sensor 1, 2

### DTC Confirmation Procedure

INFOID:000000009885734

#### **CAUTION:**

**Always drive vehicle at a safe speed.**

#### **NOTE:**

**If "DTC Confirmation Procedure" has been previously performed, always turn ignition switch "OFF" and wait at least 10 seconds before performing the next test.**

After the repair, perform the following procedure to confirm the malfunction is eliminated.

#### ④ WITH CONSULT

1. Turn ignition switch "ON". (Do not start engine.)
2. Select "DATA MONITOR" mode for "TRANSMISSION" with CONSULT.
3. Start engine and maintain the following conditions for at least 5 consecutive seconds.
  - VHCL/S SE-A/T: 40 km/h (25 MPH) or more**
  - ENGINE SPEED: 1,500 rpm or more**
  - ACCELE POSI: 0.5/8 or more**
  - SLCT LVR POSI: "D" position**
  - GEAR (Input speed sensor 1): 4th or 5th position**
  - GEAR (Input speed sensor 2): All position**
  - Driving location: Driving the vehicle uphill (increased engine load) will help maintain the driving conditions required for this test.**
4. If DTC is detected, go to [TM-56, "Diagnosis Procedure"](#).

#### ④ WITH GST

Follow the procedure "With CONSULT".

### Diagnosis Procedure

INFOID:000000009885735

#### 1. CHECK INPUT SIGNAL

##### ④ With CONSULT

1. Start engine.
2. Select "ECU INPUT SIGNALS" in "DATA MONITOR" mode for "TRANSMISSION" with CONSULT.
3. Vehicle start and read out the value of "INPUT SPEED".



# P0717 INPUT SPEED SENSOR A

## < DTC/CIRCUIT DIAGNOSIS >

Item name	Condition	Display value (rpm)
INPUT SPEED	During driving (lock-up ON)	Approximately matches the engine speed.

### OK or NG

OK >> GO TO 4.

NG >> GO TO 2.

## 2. CHECK TCM POWER SUPPLY AND GROUND CIRCUIT

Check TCM power supply and ground circuit. Refer to [TM-105, "Diagnosis Procedure"](#).

### OK or NG

OK >> GO TO 3.

NG >> Repair or replace damaged parts.

## 3. DETECT MALFUNCTIONING ITEM

Check the following items:

- The A/T assembly harness connector pin terminals for damage or loose connection with harness connector.

### OK or NG

OK >> Replace the control valve with TCM. Refer to [TM-201, "Control Valve with TCM"](#).

NG >> Repair or replace damaged parts.

## 4. CHECK DTC

Perform "DTC Confirmation Procedure".

- Refer to [TM-56, "DTC Confirmation Procedure"](#).

### OK or NG

OK >> **INSPECTION END**

NG >> GO TO 2.

A  
B  
C  
TM  
E  
F  
G  
H  
I  
J  
K  
L  
M  
N  
O  
P

# P0720 OUTPUT SPEED SENSOR

< DTC/CIRCUIT DIAGNOSIS >

## P0720 OUTPUT SPEED SENSOR

### Description

INFOID:000000009885736

The output speed sensor detects the revolution of the parking gear and emits a pulse signal. The pulse signal is sent to the TCM which converts it into vehicle speed.

### CONSULT Reference Value in Data Monitor Mode

INFOID:000000009885737

Item name	Condition	Display value (km/h)
VHCL/S SE-A/T	During driving	Approximately matches the speedometer reading.

### On Board Diagnosis Logic

INFOID:000000009885738

- This is an OBD-II self-diagnostic item.
- Diagnostic trouble code “P0720” with CONSULT or 1st judgment flicker without CONSULT is detected under the following conditions.
  - When TCM does not receive the proper voltage signal from the sensor.
  - After ignition switch is turned “ON”, irregular vehicle speed signal input from combination meter before the vehicle starts moving.

### Possible Cause

INFOID:000000009885739

- Harness or connectors  
(The sensor circuit is open or shorted.)
- Output speed sensor
- Vehicle speed signal

### DTC Confirmation Procedure

INFOID:000000009885740

#### CAUTION:

- Always drive vehicle at a safe speed.
- Be careful not to rev engine into the red zone on the tachometer.

#### NOTE:

If “DTC Confirmation Procedure” has been previously performed, always turn ignition switch “OFF” and wait at least 10 seconds before performing the next test.

After the repair, perform the following procedure to confirm the malfunction is eliminated.

#### Ⓟ WITH CONSULT

1. Turn ignition switch “ON”. (Do not start engine.)
2. Select “DATA MONITOR” mode for “TRANSMISSION” with CONSULT.
3. Drive vehicle and check for an increase of “VHCL/S SE-A/T” value in response to “VHCL/S SE-MTR” value.  
If the check result is NG, go to [TM-59, "Diagnosis Procedure"](#).  
If the check result is OK, go to following step.
4. Select “DATA MONITOR” mode for “TRANSMISSION” with CONSULT.
5. Start engine and maintain the following conditions for at least 5 consecutive seconds.  
**VHCL/S SE-A/T: 30 km/h (19 MPH) or more**  
**ACCELE POSI: More than 1.0/8**  
**SLCT LVR POSI: “D” position**  
**Driving location: Driving the vehicle uphill (increased engine load) will help maintain the driving conditions required for this test.**  
If the check result is NG, go to [TM-59, "Diagnosis Procedure"](#).  
If the check result is OK, go to following step.
6. Maintain the following conditions for at least 5 consecutive seconds.  
**ENGINE SPEED: 3,500 rpm or more**  
**ACCELE POSI: More than 1.0/8**  
**SLCT LVR POSI: “D” position**  
**Driving location: Driving the vehicle uphill (increased engine load) will help maintain the driving conditions required for this test.**  
If the check result is NG, go to [TM-59, "Diagnosis Procedure"](#).

# P0720 OUTPUT SPEED SENSOR

## < DTC/CIRCUIT DIAGNOSIS >

### WITH GST

Follow the procedure "With CONSULT".

## Diagnosis Procedure

INFOID:000000009885741

### 1. CHECK INPUT SIGNAL

#### With CONSULT

1. Turn ignition switch "ON".
2. Select "ECU INPUT SIGNALS" in "DATA MONITOR" mode for "TRANSMISSION" with CONSULT.
3. Start the engine.
4. Read out the value of "VHCL/S SE-A/T" while driving.  
Check the value changes according to driving speed.

Item name	Condition	Display value (km/h)
VHCL/S SE-A/T	During driving	Approximately matches the speedometer reading.

#### OK or NG

- OK >> GO TO 6.  
NG >> GO TO 2.

### 2. CHECK TCM POWER SUPPLY AND GROUND CIRCUIT

Check TCM power supply and ground circuit. Refer to [TM-105. "Diagnosis Procedure"](#).

#### OK or NG

- OK >> GO TO 3.  
NG >> Repair or replace damaged parts.

### 3. DETECT MALFUNCTIONING ITEM

Check the following items:

- The A/T assembly harness connector pin terminals for damage or loose connection with harness connector.

#### OK or NG

- OK >> GO TO 4.  
NG >> Repair or replace damaged parts.

### 4. CHECK SUB-HARNESS

1. Remove control valve with TCM. Refer to [TM-201. "Control Valve with TCM"](#).
2. Disconnect transmission range switch connector and TCM connector.
3. Check continuity between transmission range switch connector (A) terminals and TCM connector (B) terminals.

Item	Connector	Terminal	Continuity
Transmission range switch connector	F505	8	Yes
TCM connector	F503	20	
Transmission range switch connector	F505	9	Yes
TCM connector	F503	17	
Transmission range switch connector	F505	10	Yes
TCM connector	F503	16	

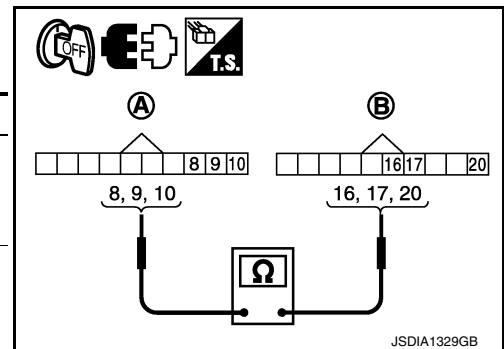

4. If OK, check harness for short to ground and short to power.
5. Reinstall any part removed.

#### OK or NG

- OK >> GO TO 5.  
NG >> Replace open circuit or short to ground and short to power in harness or connectors.

### 5. REPLACE THE OUTPUT SPEED SENSOR AND CHECK DTC

## P0720 OUTPUT SPEED SENSOR

< DTC/CIRCUIT DIAGNOSIS >

---

1. Replace the output speed sensor. Refer to [TM-229, "Disassembly"](#).
2. Perform "DTC Confirmation Procedure". Refer to [TM-58, "DTC Confirmation Procedure"](#).

OK or NG

OK >> **INSPECTION END**

NG >> Replace the control valve with TCM. Refer to [TM-201, "Control Valve with TCM"](#).

### 6. CHECK DTC

---

Perform "DTC Confirmation Procedure".

- Refer to [TM-58, "DTC Confirmation Procedure"](#).

OK or NG

OK >> **INSPECTION END**

NG >> GO TO 2.

# P0725 ENGINE SPEED

< DTC/CIRCUIT DIAGNOSIS >

## P0725 ENGINE SPEED

### Description

INFOID:000000009885742

The engine speed signal is sent from the ECM to the TCM.

### CONSULT Reference Value in Data Monitor Mode

INFOID:000000009885743

Item name	Condition	Display value (rpm)
ENGINE SPEED	Engine running	Closely matches the tachometer reading.

### On Board Diagnosis Logic

INFOID:000000009885744

- This is not an OBD-II self-diagnostic item.
- Diagnostic trouble code “P0725” with CONSULT or 16th judgment flicker without CONSULT is detected when TCM does not receive the ignition signal from ECM during engine cranking or running.

### Possible Cause

INFOID:000000009885745

Harness or connectors  
(The ECM to the TCM circuit is open or shorted.)

### DTC Confirmation Procedure

INFOID:000000009885746

#### CAUTION:

**Always drive vehicle at a safe speed.**

#### NOTE:

**If “DTC Confirmation Procedure” has been previously performed, always turn ignition switch “OFF” and wait at least 10 seconds before performing the next test.**

After the repair, perform the following procedure to confirm the malfunction is eliminated.

#### ④ WITH CONSULT

1. Turn ignition switch “ON” and select “DATA MONITOR” mode for “TRANSMISSION” with CONSULT.
2. Start engine and maintain the following conditions for at least 10 consecutive seconds.  
**VHCL/S SE-A/T: 10 km/h (6 MPH) or more**  
**ACCELE POSI: More than 1/8**  
**SLCT LVR POSI: “D” position**
3. If DTC is detected, go to [TM-61. "Diagnosis Procedure"](#).

### Diagnosis Procedure

INFOID:000000009885747

#### 1.CHECK CAN COMMUNICATION LINE

Perform the self-diagnosis. Refer to [TM-38. "CONSULT Function \(TRANSMISSION\)"](#).

Is a malfunction in the CAN communication indicated in the results?

- YES >> Check CAN communication line. Refer to [TM-48](#).  
NO >> GO TO 2.

#### 2.CHECK DTC WITH TCM

##### ④ With CONSULT

1. Start engine.
2. Select “ECU INPUT SIGNALS” in “DATA MONITOR” mode for “TRANSMISSION” with CONSULT.
3. While monitoring engine speed, check for engine speed change corresponding to wide-open throttle position signal.

Item name	Condition	Display value (rpm)
ENGINE SPEED	Engine running	Closely matches the tachometer reading.

#### OK or NG

- OK >> GO TO 3.

## P0725 ENGINE SPEED

### < DTC/CIRCUIT DIAGNOSIS >

---

- NG >> Check the ignition signal circuit.  
• Refer to [EC-469, "Diagnosis Procedure"](#).

### 3.CHECK DTC

---

Perform "DTC Confirmation Procedure".

- Refer to [TM-61, "DTC Confirmation Procedure"](#).

#### OK or NG

- OK >> **INSPECTION END**  
NG >> GO TO 4.

### 4.CHECK TCM POWER SUPPLY AND GROUND CIRCUIT

---

Check TCM power supply and ground circuit. Refer to [TM-105, "Diagnosis Procedure"](#).

#### OK or NG

- OK >> GO TO 5.  
NG >> Repair or replace damaged parts.

### 5.DETECT MALFUNCTIONING ITEM

---

Check the following items:

- The A/T assembly harness connector pin terminals for damage or loose connection with harness connector.

#### OK or NG

- OK >> Replace the control valve with TCM. Refer to [TM-201, "Control Valve with TCM"](#).  
NG >> Repair or replace damaged parts.

# P0731 1GR INCORRECT RATIO

< DTC/CIRCUIT DIAGNOSIS >

## P0731 1GR INCORRECT RATIO

### Description

INFOID:000000009885748

This malfunction is detected when the A/T does not shift into 1GR position as instructed by TCM. This is not only caused by electrical malfunction (circuits open or shorted) but also by mechanical malfunction such as control valve sticking, improper solenoid valve operation.

### On Board Diagnosis Logic

INFOID:000000009885749

- This is an OBD-II self-diagnostic item.
- Diagnostic trouble code "P0731" with CONSULT or 18th judgment flicker without CONSULT is detected when TCM detects any inconsistency in the actual gear ratio.

### Possible Cause

INFOID:000000009885750

- Harness or connectors  
(Solenoid circuits are open or shorted.)
- Input clutch solenoid valve
- Front brake solenoid valve
- Direct clutch solenoid valve
- High and low reverse clutch solenoid valve
- Each clutch
- Hydraulic control circuit

### DTC Confirmation Procedure

INFOID:000000009885751

#### **CAUTION:**

**Always drive vehicle at a safe speed.**

#### **NOTE:**

**If "DTC Confirmation Procedure" has been previously performed, always turn ignition switch OFF and wait at least 10 seconds before performing the next test.**

After the repair, perform the following procedure to confirm the malfunction is eliminated.

#### WITH CONSULT

1. Start the engine and select "DATA MONITOR" mode for "TRANSMISSION" with CONSULT.
2. Make sure that "ATF TEMP 1" is within the following range.  
**ATF TEMP 1: 20°C – 140°C**  
If out of range, drive vehicle to warm ATF or stop engine to cool ATF.
3. Select "1ST GR FNCTN P0731" of "DTC & SRT CONFIRMATION" mode for "TRANSMISSION" with CONSULT.
4. Drive vehicle and maintain the following conditions.  
Floor shift models:  
**SLCT LVR POSI: "1" position**  
**GEAR: "1" position**  
**ACCELE POSI: 0.6/8 or more**  
**VEHICLE SPEED: 10 km/h (6 MPH) or more**  
**ENGINE SPEED: INPUT SPEED – 50 rpm or more**  
**INPUT SPEED: 300 rpm or more**

Column shift models:

- MANU MODE SW: ON**  
**GEAR: "1" position**  
**ACCELE POSI: 0.6/8 or more**  
**VEHICLE SPEED: 10 km/h (6 MPH) or more**  
**ENGINE SPEED: INPUT SPEED – 50 rpm or more**  
**INPUT SPEED: 300 rpm or more**

5. Keep the current driving status for at least 5 consecutive seconds if CONSULT screen changes from "OUT OF CONDITION" to "TESTING".

#### **CAUTION:**

**If "TESTING" does not appear on CONSULT for a long time, select "SELF-DIAG RESULTS". In case a 1st trip DTC other than P0731 is shown, refer to "[TM-123, "DTC No. Index"](#)".**

# P0731 1GR INCORRECT RATIO

## < DTC/CIRCUIT DIAGNOSIS >

---

If "COMPLETED RESULT NG" is detected, go to [TM-64. "Diagnosis Procedure"](#).

If "STOP VEHICLE" is detected, go to the following step.

6. Stop vehicle.
7. Drive vehicle in "D" position allowing it to shift from 1GR to 5GR and check shift timing and shift shock.
  - Touch "OK" to complete the inspection when normally shifted from the 1GR to 5GR.
  - Touch "NG" when an unusual shift shock, etc. occurs in spite of shifting from the 1GR to 5GR. Go to [TM-183. "Description"](#).
  - Perform [TM-38. "CONSULT Function \(TRANSMISSION\)"](#) when not shifted from the 1GR to 5GR. (Neither "OK" nor "NG" are indicated.)

## Diagnosis Procedure

INFOID:000000009885752

### 1. CHECK CAN COMMUNICATION LINE

---

Perform self-diagnosis. Refer to [TM-38. "CONSULT Function \(TRANSMISSION\)"](#).

Is a malfunction in the CAN communication indicated in the results?

YES >> Check CAN communication line. Refer to [TM-48. "Diagnosis Procedure"](#).

NO >> GO TO 2.

### 2. CHECK TCM POWER SUPPLY AND GROUND CIRCUIT

---

Check TCM power supply and ground circuit. Refer to [TM-105. "Diagnosis Procedure"](#).

OK or NG

OK >> GO TO 3.

NG >> Repair or replace damaged parts.

### 3. DETECT MALFUNCTION ITEM

---

Check A/T assembly harness connector pin terminals for damage or loose connection with harness connector.

OK or NG

OK >> GO TO 4.

NG >> Repair or replace damaged parts.

### 4. REPLACE CONTROL VALVE WITH TCM

---

1. Replace control valve with TCM. Refer to [TM-201. "Control Valve with TCM"](#).

2. Perform [TM-63. "DTC Confirmation Procedure"](#).

OK or NG

OK >> **INSPECTION END**

NG >> Confirm malfunction phenomena by "ROAD TEST" to repair malfunctioning part. Refer to [TM-183. "Description"](#).



# P0732 2GR INCORRECT RATIO

< DTC/CIRCUIT DIAGNOSIS >

## P0732 2GR INCORRECT RATIO

### Description

INFOID:000000009885753

This malfunction is detected when the A/T does not shift into 2GR position as instructed by TCM. This is not only caused by electrical malfunction (circuits open or shorted) but also by mechanical malfunction such as control valve sticking, improper solenoid valve operation.

### On Board Diagnosis Logic

INFOID:000000009885754

- This is an OBD-II self-diagnostic item.
- Diagnostic trouble code "P0732" with CONSULT or 19th judgment flicker without CONSULT is detected when TCM detects any inconsistency in the actual gear ratio.

### Possible Cause

INFOID:000000009885755

- Harness or connectors  
(Solenoid circuits are open or shorted.)
- Input clutch solenoid valve
- Front brake solenoid valve
- Direct clutch solenoid valve
- High and low reverse clutch solenoid valve
- Each clutch
- Hydraulic control circuit

### DTC Confirmation Procedure

INFOID:000000009885756

#### **CAUTION:**

**Always drive vehicle at a safe speed.**

#### **NOTE:**

**If "DTC Confirmation Procedure" has been previously performed, always turn ignition switch OFF and wait at least 10 seconds before performing the next test.**

After the repair, perform the following procedure to confirm the malfunction is eliminated.

#### WITH CONSULT

1. Start the engine and select "DATA MONITOR" mode for "TRANSMISSION" with CONSULT.
2. Make sure that "ATF TEMP 1" is within the following range.  
**ATF TEMP 1: 20°C – 140°C**  
If out of range, drive vehicle to warm ATF or stop engine to cool ATF.
3. Select "2ND GR FNCTN P0732" of "DTC & SRT CONFIRMATION" mode for "TRANSMISSION" with CONSULT.
4. Drive vehicle and maintain the following conditions.  
Floor shift models:  
**SLCT LVR POSI: "2" position**  
**GEAR: "2" position**  
**ACCELE POSI: 0.6/8 or more**  
**VEHICLE SPEED: 10 km/h (6 MPH) or more**  
**ENGINE SPEED: INPUT SPEED – 50 rpm or more**  
**INPUT SPEED: 300 rpm or more**

Column shift models:

- MANU MODE SW: ON**  
**GEAR: "2" position**  
**ACCELE POSI: 0.6/8 or more**  
**VEHICLE SPEED: 10 km/h (6 MPH) or more**  
**ENGINE SPEED: INPUT SPEED – 50 rpm or more**  
**INPUT SPEED: 300 rpm or more**
5. Keep the current driving status for at least 5 consecutive seconds if CONSULT screen changes from "OUT OF CONDITION" to "TESTING".

#### **CAUTION:**

**If "TESTING" does not appear on CONSULT for a long time, select "SELF-DIAG RESULTS". In case a 1st trip DTC other than P0732 is shown, refer to "[TM-123, "DTC No. Index"](#)".**

# P0732 2GR INCORRECT RATIO

## < DTC/CIRCUIT DIAGNOSIS >

---

If "COMPLETED RESULT NG" is detected, go to [TM-66. "Diagnosis Procedure"](#).

If "STOP VEHICLE" is detected, go to the following step.

6. Stop vehicle.
7. Drive vehicle in "D" position allowing it to shift from 1GR to 5GR and check shift timing and shift shock.
  - Touch "OK" to complete the inspection when normally shifted from the 1GR to 5GR.
  - Touch "NG" when an unusual shift shock, etc. occurs in spite of shifting from the 1GR to 5GR. Go to [TM-183. "Description"](#).
  - Perform [TM-38. "CONSULT Function \(TRANSMISSION\)"](#) when not shifted from the 1GR to 5GR. (Neither "OK" nor "NG" are indicated.)

## Diagnosis Procedure

INFOID:000000009885757

### 1. CHECK CAN COMMUNICATION LINE

---

Perform self-diagnosis. Refer to [TM-38. "CONSULT Function \(TRANSMISSION\)"](#).

Is a malfunction in the CAN communication indicated in the results?

YES >> Check CAN communication line. Refer to [TM-48. "Diagnosis Procedure"](#).

NO >> GO TO 2.

### 2. CHECK TCM POWER SUPPLY AND GROUND CIRCUIT

---

Check TCM power supply and ground circuit. Refer to [TM-105. "Diagnosis Procedure"](#).

OK or NG

OK >> GO TO 3.

NG >> Repair or replace damaged parts.

### 3. DETECT MALFUNCTION ITEM

---

Check A/T assembly harness connector pin terminals for damage or loose connection with harness connector.

OK or NG

OK >> GO TO 4.

NG >> Repair or replace damaged parts.

### 4. REPLACE CONTROL VALVE WITH TCM

---

1. Replace control valve with TCM. Refer to [TM-201. "Control Valve with TCM"](#).

2. Perform [TM-65. "DTC Confirmation Procedure"](#).

OK or NG

OK >> **INSPECTION END**

NG >> Confirm malfunction phenomena by "ROAD TEST" to repair malfunctioning part. Refer to [TM-183. "Description"](#).

# P0733 3GR INCORRECT RATIO

< DTC/CIRCUIT DIAGNOSIS >

## P0733 3GR INCORRECT RATIO

### Description

INFOID:000000009885758

This malfunction is detected when the A/T does not shift into 3GR position as instructed by TCM. This is not only caused by electrical malfunction (circuits open or shorted) but also by mechanical malfunction such as control valve sticking, improper solenoid valve operation.

### On Board Diagnosis Logic

INFOID:000000009885759

- This is an OBD-II self-diagnostic item.
- Diagnostic trouble code "P0733" with CONSULT or 20th judgment flicker without CONSULT is detected when TCM detects any inconsistency in the actual gear ratio.

### Possible Cause

INFOID:000000009885760

- Harness or connectors  
(Solenoid circuits are open or shorted.)
- Input clutch solenoid valve
- Front brake solenoid valve
- Direct clutch solenoid valve
- High and low reverse clutch solenoid valve
- Each clutch
- Hydraulic control circuit

### DTC Confirmation Procedure

INFOID:000000009885761

#### **CAUTION:**

**Always drive vehicle at a safe speed.**

#### **NOTE:**

**If "DTC Confirmation Procedure" has been previously performed, always turn ignition switch OFF and wait at least 10 seconds before performing the next test.**

After the repair, perform the following procedure to confirm the malfunction is eliminated.

#### WITH CONSULT

1. Start the engine and select "DATA MONITOR" mode for "TRANSMISSION" with CONSULT.
2. Make sure that "ATF TEMP 1" is within the following range.  
**ATF TEMP 1: 20°C – 140°C**  
If out of range, drive vehicle to warm ATF or stop engine to cool ATF.
3. Select "3RD GR FNCTN P0733" of "DTC & SRT CONFIRMATION" mode for "TRANSMISSION" with CONSULT.
4. Drive vehicle and maintain the following conditions.  
Floor shift models:  
**SLCT LVR POSI: "3" position**  
**GEAR: "3" position**  
**ACCELE POSI: 0.6/8 or more**  
**VEHICLE SPEED: 10 km/h (6 MPH) or more**  
**ENGINE SPEED: INPUT SPEED – 50 rpm or more**  
**INPUT SPEED: 300 rpm or more**

Column shift models:

- MANU MODE SW: ON**  
**GEAR: "3" position**  
**ACCELE POSI: 0.6/8 or more**  
**VEHICLE SPEED: 10 km/h (6 MPH) or more**  
**ENGINE SPEED: INPUT SPEED – 50 rpm or more**  
**INPUT SPEED: 300 rpm or more**
5. Keep the current driving status for at least 5 consecutive seconds if CONSULT screen changes from "OUT OF CONDITION" to "TESTING".

#### **CAUTION:**

**If "TESTING" does not appear on CONSULT for a long time, select "SELF-DIAG RESULTS". In case a 1st trip DTC other than P0733 is shown, refer to "[TM-123, "DTC No. Index"](#)".**

# P0733 3GR INCORRECT RATIO

## < DTC/CIRCUIT DIAGNOSIS >

---

If "COMPLETED RESULT NG" is detected, go to [TM-68. "Diagnosis Procedure"](#).

If "STOP VEHICLE" is detected, go to the following step.

6. Stop vehicle.
7. Drive vehicle in "D" position allowing it to shift from 1GR to 5GR and check shift timing and shift shock.
  - Touch "OK" to complete the inspection when normally shifted from the 1GR to 5GR.
  - Touch "NG" when an unusual shift shock, etc. occurs in spite of shifting from the 1GR to 5GR. Go to [TM-183. "Description"](#).
  - Perform [TM-38. "CONSULT Function \(TRANSMISSION\)"](#) when not shifted from the 1GR to 5GR. (Neither "OK" nor "NG" are indicated.)

## Diagnosis Procedure

INFOID:000000009885762

### 1. CHECK CAN COMMUNICATION LINE

---

Perform self-diagnosis. Refer to [TM-38. "CONSULT Function \(TRANSMISSION\)"](#).

Is a malfunction in the CAN communication indicated in the results?

YES >> Check CAN communication line. Refer to [TM-48. "Diagnosis Procedure"](#).

NO >> GO TO 2.

### 2. CHECK TCM POWER SUPPLY AND GROUND CIRCUIT

---

Check TCM power supply and ground circuit. Refer to [TM-105. "Diagnosis Procedure"](#).

OK or NG

OK >> GO TO 3.

NG >> Repair or replace damaged parts.

### 3. DETECT MALFUNCTION ITEM

---

Check A/T assembly harness connector pin terminals for damage or loose connection with harness connector.

OK or NG

OK >> GO TO 4.

NG >> Repair or replace damaged parts.

### 4. REPLACE CONTROL VALVE WITH TCM

---

1. Replace control valve with TCM. Refer to [TM-201. "Control Valve with TCM"](#).

2. Perform [TM-67. "DTC Confirmation Procedure"](#).

OK or NG

OK >> **INSPECTION END**

NG >> Confirm malfunction phenomena by "ROAD TEST" to repair malfunctioning part. Refer to [TM-183. "Description"](#).

# P0734 4GR INCORRECT RATIO

< DTC/CIRCUIT DIAGNOSIS >

## P0734 4GR INCORRECT RATIO

### Description

INFOID:000000009885763

This malfunction is detected when the A/T does not shift into 4GR position as instructed by TCM. This is not only caused by electrical malfunction (circuits open or shorted) but also by mechanical malfunction such as control valve sticking, improper solenoid valve operation.

### On Board Diagnosis Logic

INFOID:000000009885764

- This is an OBD-II self-diagnostic item.
- Diagnostic trouble code "P0734" with CONSULT or 21th judgment flicker without CONSULT is detected when TCM detects any inconsistency in the actual gear ratio.

### Possible Cause

INFOID:000000009885765

- Harness or connectors  
(Solenoid circuits are open or shorted.)
- Input clutch solenoid valve
- Front brake solenoid valve
- Direct clutch solenoid valve
- High and low reverse clutch solenoid valve
- Each clutch
- Hydraulic control circuit

### DTC Confirmation Procedure

INFOID:000000009885766

#### **CAUTION:**

**Always drive vehicle at a safe speed.**

#### **NOTE:**

**If "DTC Confirmation Procedure" has been previously performed, always turn ignition switch OFF and wait at least 10 seconds before performing the next test.**

After the repair, perform the following procedure to confirm the malfunction is eliminated.

#### WITH CONSULT

1. Start the engine and select "DATA MONITOR" mode for "TRANSMISSION" with CONSULT.
2. Make sure that "ATF TEMP 1" is within the following range.  
**ATF TEMP 1: 20°C – 140°C**  
If out of range, drive vehicle to warm ATF or stop engine to cool ATF.
3. Select "4TH GR FNCTN P0734" of "DTC & SRT CONFIRMATION" mode for "TRANSMISSION" with CONSULT.
4. Drive vehicle and maintain the following conditions.  
Floor shift models:  
**SLCT LVR POSI: "4" position**  
**GEAR: "4" position**  
**ACCELE POSI: 0.6/8 or more**  
**VEHICLE SPEED: 10 km/h (6 MPH) or more**  
**ENGINE SPEED: INPUT SPEED – 50 rpm or more**  
**INPUT SPEED: 300 rpm or more**

Column shift models:

- MANU MODE SW: ON**  
**GEAR: "4" position**  
**ACCELE POSI: 0.6/8 or more**  
**VEHICLE SPEED: 10 km/h (6 MPH) or more**  
**ENGINE SPEED: INPUT SPEED – 50 rpm or more**  
**INPUT SPEED: 300 rpm or more**
5. Keep the current driving status for at least 5 consecutive seconds if CONSULT screen changes from "OUT OF CONDITION" to "TESTING".

#### **CAUTION:**

**If "TESTING" does not appear on CONSULT for a long time, select "SELF-DIAG RESULTS". In case a 1st trip DTC other than P0734 is shown, refer to "[TM-123, "DTC No. Index"](#)".**

# P0734 4GR INCORRECT RATIO

## < DTC/CIRCUIT DIAGNOSIS >

---

If "COMPLETED RESULT NG" is detected, go to [TM-70, "Diagnosis Procedure"](#).

If "STOP VEHICLE" is detected, go to the following step.

6. Stop vehicle.
7. Drive vehicle in "D" position allowing it to shift from 1GR to 5GR and check shift timing and shift shock.
  - Touch "OK" to complete the inspection when normally shifted from the 1GR to 5GR.
  - Touch "NG" when an unusual shift shock, etc. occurs in spite of shifting from the 1GR to 5GR. Go to [TM-183, "Description"](#).
  - Perform [TM-38, "CONSULT Function \(TRANSMISSION\)"](#) when not shifted from the 1GR to 5GR. (Neither "OK" nor "NG" are indicated.)

## Diagnosis Procedure

INFOID:000000009885767

### 1. CHECK CAN COMMUNICATION LINE

---

Perform self-diagnosis. Refer to [TM-38, "CONSULT Function \(TRANSMISSION\)"](#).

Is a malfunction in the CAN communication indicated in the results?

YES >> Check CAN communication line. Refer to [TM-48, "Diagnosis Procedure"](#).

NO >> GO TO 2.

### 2. CHECK TCM POWER SUPPLY AND GROUND CIRCUIT

---

Check TCM power supply and ground circuit. Refer to [TM-105, "Diagnosis Procedure"](#).

OK or NG

OK >> GO TO 3.

NG >> Repair or replace damaged parts.

### 3. DETECT MALFUNCTION ITEM

---

Check A/T assembly harness connector pin terminals for damage or loose connection with harness connector.

OK or NG

OK >> GO TO 4.

NG >> Repair or replace damaged parts.

### 4. REPLACE CONTROL VALVE WITH TCM

---

1. Replace control valve with TCM. Refer to [TM-201, "Control Valve with TCM"](#).

2. Perform [TM-69, "DTC Confirmation Procedure"](#).

OK or NG

OK >> **INSPECTION END**

NG >> Confirm malfunction phenomena by "ROAD TEST" to repair malfunctioning part. Refer to [TM-183, "Description"](#).

# P0735 5GR INCORRECT RATIO

< DTC/CIRCUIT DIAGNOSIS >

## P0735 5GR INCORRECT RATIO

### Description

INFOID:000000009885768

This malfunction is detected when the A/T does not shift into 5GR position as instructed by TCM. This is not only caused by electrical malfunction (circuits open or shorted) but also by mechanical malfunction such as control valve sticking, improper solenoid valve operation.

### On Board Diagnosis Logic

INFOID:000000009885769

- This is an OBD-II self-diagnostic item.
- Diagnostic trouble code "P0735" with CONSULT or 22th judgment flicker without CONSULT is detected when TCM detects any inconsistency in the actual gear ratio.

### Possible Cause

INFOID:000000009885770

- Harness or connectors  
(Solenoid circuits are open or shorted.)
- Input clutch solenoid valve
- Front brake solenoid valve
- Direct clutch solenoid valve
- High and low reverse clutch solenoid valve
- Each clutch
- Hydraulic control circuit

### DTC Confirmation Procedure

INFOID:000000009885771

#### **CAUTION:**

**Always drive vehicle at a safe speed.**

#### **NOTE:**

**If "DTC Confirmation Procedure" has been previously performed, always turn ignition switch OFF and wait at least 10 seconds before performing the next test.**

After the repair, perform the following procedure to confirm the malfunction is eliminated.

#### WITH CONSULT

1. Start the engine and select "DATA MONITOR" mode for "TRANSMISSION" with CONSULT.
2. Make sure that "ATF TEMP 1" is within the following range.  
**ATF TEMP 1: 20°C – 140°C**  
If out of range, drive vehicle to warm ATF or stop engine to cool ATF.
3. Select "5TH GR FNCTN P0735" of "DTC & SRT CONFIRMATION" mode for "TRANSMISSION" with CONSULT.
4. Drive vehicle and maintain the following conditions.  
Floor shift models:  
**SLCT LVR POSI: "D" position**  
**GEAR: "5" position**  
**ACCELE POSI: 0.6/8 or more**  
**VEHICLE SPEED: 10 km/h (6 MPH) or more**  
**ENGINE SPEED: INPUT SPEED – 50 rpm or more**  
**INPUT SPEED: 300 rpm or more**

Column shift models:

- MANU MODE SW: ON**  
**GEAR: "5" position**  
**ACCELE POSI: 0.6/8 or more**  
**VEHICLE SPEED: 10 km/h (6 MPH) or more**  
**ENGINE SPEED: INPUT SPEED – 50 rpm or more**  
**INPUT SPEED: 300 rpm or more**

5. Keep the current driving status for at least 5 consecutive seconds if CONSULT screen changes from "OUT OF CONDITION" to "TESTING".

#### **CAUTION:**

**If "TESTING" does not appear on CONSULT for a long time, select "SELF-DIAG RESULTS". In case a 1st trip DTC other than P0735 is shown, refer to "[TM-123, "DTC No. Index"](#)".**

# P0735 5GR INCORRECT RATIO

## < DTC/CIRCUIT DIAGNOSIS >

---

If "COMPLETED RESULT NG" is detected, go to [TM-72. "Diagnosis Procedure"](#).

If "STOP VEHICLE" is detected, go to the following step.

6. Stop vehicle.
7. Drive vehicle in "D" position allowing it to shift from 1GR to 5GR and check shift timing and shift shock.
  - Touch "OK" to complete the inspection when normally shifted from the 1GR to 5GR.
  - Touch "NG" when an unusual shift shock, etc. occurs in spite of shifting from the 1GR to 5GR. Go to [TM-183. "Description"](#).
  - Perform [TM-38. "CONSULT Function \(TRANSMISSION\)"](#) when not shifted from the 1GR to 5GR. (Neither "OK" nor "NG" are indicated.)

## Diagnosis Procedure

INFOID:000000009885772

### 1. CHECK CAN COMMUNICATION LINE

---

Perform self-diagnosis. Refer to [TM-38. "CONSULT Function \(TRANSMISSION\)"](#).

Is a malfunction in the CAN communication indicated in the results?

YES >> Check CAN communication line. Refer to [TM-48. "Diagnosis Procedure"](#).

NO >> GO TO 2.

### 2. CHECK TCM POWER SUPPLY AND GROUND CIRCUIT

---

Check TCM power supply and ground circuit. Refer to [TM-105. "Diagnosis Procedure"](#).

OK or NG

OK >> GO TO 3.

NG >> Repair or replace damaged parts.

### 3. DETECT MALFUNCTION ITEM

---

Check A/T assembly harness connector pin terminals for damage or loose connection with harness connector.

OK or NG

OK >> GO TO 4.

NG >> Repair or replace damaged parts.

### 4. REPLACE CONTROL VALVE WITH TCM

---

1. Replace control valve with TCM. Refer to [TM-201. "Control Valve with TCM"](#).

2. Perform [TM-71. "DTC Confirmation Procedure"](#).

OK or NG

OK >> **INSPECTION END**

NG >> Confirm malfunction phenomena by "ROAD TEST" to repair malfunctioning part. Refer to [TM-183. "Description"](#).



# P0740 TORQUE CONVERTER

< DTC/CIRCUIT DIAGNOSIS >

## P0740 TORQUE CONVERTER

### Description

INFOID:000000009885773

- The torque converter clutch solenoid valve is activated, with the gear in D4, D5 by the TCM in response to signals sent from the output speed sensor and accelerator pedal position sensor (throttle position sensor). Torque converter clutch piston operation will then be controlled.
- Lock-up operation, however, is prohibited when A/T fluid temperature is too low.
- When the accelerator pedal is depressed (less than 1/8) in lock-up condition, the engine speed should not change abruptly. If there is a big jump in engine speed, there is no lock-up.

### CONSULT Reference Value in Data Monitor Mode

INFOID:000000009885774

Item name	Condition	Display value (Approx.)
TCC SOLENOID	When performing slip lock-up	0.2 - 0.4 A
	When performing lock-up	0.4 - 0.6 A

### On Board Diagnosis Logic

INFOID:000000009885775

- This is an OBD-II self-diagnostic item.
- Diagnostic trouble code "P0740" with CONSULT with CONSULT or 3rd judgment flicker without CONSULT is detected under the following conditions.
  - When TCM detects an improper voltage drop when it tries to operate the solenoid valve.
  - When TCM detects as irregular by comparing target value with monitor value.

### Possible Cause

INFOID:000000009885776

- Torque converter clutch solenoid valve
- Harness or connectors  
(The solenoid circuit is open or shorted.)

### DTC Confirmation Procedure

INFOID:000000009885777

#### CAUTION:

**Always drive vehicle at a safe speed.**

#### NOTE:

**If "DTC Confirmation Procedure" has been previously performed, always turn ignition switch "OFF" and wait at least 10 seconds before performing the next test.**

After the repair, perform the following procedure to confirm the malfunction is eliminated.

#### ④ WITH CONSULT

1. Turn ignition switch "ON". (Do not start engine.)
2. Select "DATA MONITOR" mode for "TRANSMISSION" with CONSULT.
3. Start engine and maintain the following conditions for at least 5 consecutive seconds.  
**VHCL/S SE-A/T: 80 km/h (50 MPH) or more**  
**ACCELE POSI: 0.5/8 - 1.0/8**  
**SLCT LVR POSI: "D" position**  
**Driving location: Driving the vehicle uphill (increased engine load) will help maintain the driving conditions required for this test.**
4. If DTC is detected go to [TM-73, "Diagnosis Procedure"](#).

#### ④ WITH GST

Follow the procedure "With CONSULT".

### Diagnosis Procedure

INFOID:000000009885778

#### 1. CHECK INPUT SIGNAL

##### ④ With CONSULT

1. Turn ignition switch "ON".
2. Select "MAIN SIGNALS" in "DATA MONITOR" mode for "TRANSMISSION" with CONSULT.

# P0740 TORQUE CONVERTER

## < DTC/CIRCUIT DIAGNOSIS >

---

3. Start engine.
4. Read out the value of "TCC SOLENOID" while driving.

Item name	Condition	Display value (Approx.)
TCC SOLENOID	When performing slip lock-up	0.2 - 0.4 A
	When performing lock-up	0.4 - 0.6 A

---

### OK or NG

- OK >> GO TO 4.  
NG >> GO TO 2.

## 2. CHECK TCM POWER SUPPLY AND GROUND CIRCUIT

---

Check TCM power supply and ground circuit. Refer to [TM-105, "Diagnosis Procedure"](#).

### OK or NG

- OK >> GO TO 3.  
NG >> Repair or replace damaged parts.

## 3. DETECT MALFUNCTIONING ITEM

---

Check the following items:

- The A/T assembly harness connector pin terminals for damage or loose connection with harness connector.

### OK or NG

- OK >> Replace the control valve with TCM. Refer to [TM-201, "Control Valve with TCM"](#).  
NG >> Repair or replace damaged parts.

## 4. CHECK DTC

---

Perform "DTC Confirmation Procedure".

- Refer to [TM-73, "DTC Confirmation Procedure"](#).

### OK or NG

- OK >> **INSPECTION END**  
NG >> GO TO 2.

# P0744 TORQUE CONVERTER

< DTC/CIRCUIT DIAGNOSIS >

## P0744 TORQUE CONVERTER

### Description

INFOID:000000009885779

This malfunction is detected when the A/T does not lock-up. This is not only caused by electrical malfunction (circuits open or shorted) but also by mechanical malfunction such as control valve sticking, improper solenoid valve operation, etc.

### CONSULT Reference Value in Data Monitor Mode

INFOID:000000009885780

Item name	Condition	Display value (Approx.)
TCC SOLENOID	When performing slip lock-up	0.2 - 0.4 A
	When performing lock-up	0.4 - 0.6 A

### On Board Diagnosis Logic

INFOID:000000009885781

- This is an OBD-II self-diagnostic item.
- Diagnostic trouble code "P0744" with CONSULT or 3rd judgment flicker without CONSULT is detected under the following conditions.
  - When A/T cannot perform lock-up even if electrical circuit is good.
  - When TCM detects as irregular by comparing difference value with slip rotation.

### Possible Cause

INFOID:000000009885782

- Harness or connectors  
(The solenoid circuit is open or shorted.)
- Torque converter clutch solenoid valve
- Hydraulic control circuit

### DTC Confirmation Procedure

INFOID:000000009885783

#### **CAUTION:**

**Always drive vehicle at a safe speed.**

#### **NOTE:**

**If "DTC Confirmation Procedure" has been previously performed, always turn ignition switch "OFF" and wait at least 10 seconds before performing the next test.**

After the repair, perform the following procedure to confirm the malfunction is eliminated.

#### WITH CONSULT

1. Start engine.
2. Select "DATA MONITOR" mode for "TRANSMISSION" with CONSULT.
3. Drive vehicle and maintain the following conditions for at least 30 consecutive seconds.
  - ACCELE POSI: More than 1.0/8**
  - SLCT LVR POSI: "D" position**
  - TCC SOLENOID: 0.4 - 0.6 A**
  - VEHICLE SPEED: 80 km/h (50 MPH) or more**
  - Driving locations: Driving the vehicle uphill (increased engine load) will help maintain the driving conditions required for this test.**
4. If DTC is detected, go to [TM-75. "Diagnosis Procedure"](#).

#### WITH GST

Follow the procedure "With CONSULT".

### Diagnosis Procedure

INFOID:000000009885784

#### 1. CHECK INPUT SIGNAL

##### With CONSULT

1. Turn ignition switch "ON".
2. Select "MAIN SIGNALS" in "DATA MONITOR" mode for "TRANSMISSION" with CONSULT.
3. Start the engine.

# P0744 TORQUE CONVERTER

## < DTC/CIRCUIT DIAGNOSIS >

4. Read out the value of "TCC SOLENOID" while driving.

Item name	Condition	Display value (Approx.)
TCC SOLENOID	When performing slip lock-up	0.2 - 0.4 A
	When performing lock-up	0.4 - 0.6 A

### OK or NG

OK >> GO TO 4.

NG >> GO TO 2.

## 2. CHECK TCM POWER SUPPLY AND GROUND CIRCUIT

Check TCM power supply and ground circuit. Refer to [TM-105, "Diagnosis Procedure"](#).

### OK or NG

OK >> GO TO 3.

NG >> Repair or replace damaged parts.

## 3. DETECT MALFUNCTIONING ITEM

Check the following items:

- The A/T assembly harness connector pin terminals for damage or loose connection with harness connector.

### OK or NG

OK >> Replace the control valve with TCM. Refer to [TM-201, "Control Valve with TCM"](#).

NG >> Repair or replace damaged parts.

## 4. CHECK DTC

Perform "DTC Confirmation Procedure".

- Refer to [TM-75, "DTC Confirmation Procedure"](#).

### OK or NG

OK >> **INSPECTION END**

NG >> GO TO 2.

# P0745 PRESSURE CONTROL SOLENOID A

< DTC/CIRCUIT DIAGNOSIS >

## P0745 PRESSURE CONTROL SOLENOID A

### Description

INFOID:000000009885785

The line pressure solenoid valve regulates the oil pump discharge pressure to suit the driving condition in response to a signal sent from the TCM.

### CONSULT Reference Value in Data Monitor Mode

INFOID:000000009885786

Item name	Condition	Display value (Approx.)
LINE PRES SOL	During driving	0.2 - 0.6 A

### On Board Diagnosis Logic

INFOID:000000009885787

- This is an OBD-II self-diagnostic item.
- Diagnostic trouble code "P0745" with CONSULT or 4th judgment flicker without CONSULT is detected under the following conditions.
  - When TCM detects an improper voltage drop when it tries to operate the solenoid valve.
  - When TCM detects as irregular by comparing target value with monitor value.

### Possible Cause

INFOID:000000009885788

- Harness or connectors  
(The solenoid circuit is open or shorted.)
- Line pressure solenoid valve

### DTC Confirmation Procedure

INFOID:000000009885789

#### NOTE:

If "DTC Confirmation Procedure" has been previously performed, always turn ignition switch "OFF" and wait at least 10 seconds before performing the next test.

After the repair, perform the following procedure to confirm the malfunction is eliminated.

#### WITH CONSULT

1. Turn ignition switch "ON" and select "DATA MONITOR" mode for "TRANSMISSION" with CONSULT.
2. Engine start and wait at least 5 second.
3. If DTC is detected, go to [TM-77, "Diagnosis Procedure"](#).

#### WITH GST

Follow the procedure "With CONSULT".

### Diagnosis Procedure

INFOID:000000009885790

#### 1. CHECK INPUT SIGNAL

##### With CONSULT

1. Turn ignition switch "ON".
2. Select "MAIN SIGNALS" in "DATA MONITOR" mode for "TRANSMISSION" with CONSULT.
3. Start the engine.
4. Read out the value of "LINE PRES SOL" while driving.

Item name	Condition	Display value (Approx.)
LINE PRES SOL	During driving	0.2 - 0.6 A

#### OK or NG

- OK >> GO TO 4.
- NG >> GO TO 2.

#### 2. CHECK TCM POWER SUPPLY AND GROUND CIRCUIT

Check TCM power supply and ground circuit. Refer to [TM-105, "Diagnosis Procedure"](#).

## P0745 PRESSURE CONTROL SOLENOID A

< DTC/CIRCUIT DIAGNOSIS >

---

OK or NG

- OK >> GO TO 3.
- NG >> Repair or replace damaged parts.

### 3. DETECT MALFUNCTIONING ITEM

---

Check the following items:

- The A/T assembly harness connector pin terminals for damage or loose connection with harness connector.

OK or NG

- OK >> Replace the control valve with TCM. Refer to [TM-201, "Control Valve with TCM"](#).
- NG >> Repair or replace damaged parts.

### 4. CHECK DTC

---

Perform "DTC Confirmation Procedure".

- Refer to [TM-77, "DTC Confirmation Procedure"](#).

OK or NG

- OK >> **INSPECTION END**
- NG >> GO TO 2.

# P1705 TP SENSOR

< DTC/CIRCUIT DIAGNOSIS >

## P1705 TP SENSOR

### Description

INFOID:000000009885791

Electric throttle control actuator consists of throttle control motor, accelerator pedal position sensor, throttle position sensor, etc. The actuator sends a signal to the ECM, and ECM sends signals to TCM with CAN communication.

### CONSULT Reference Value in Data Monitor Mode

INFOID:000000009885792

Item name	Condition	Display value (Approx.)
ACCELE POSI	Released accelerator pedal.	0.0/8
	Fully depressed accelerator pedal.	8/8

### On Board Diagnosis Logic

INFOID:000000009885793

- This is not an OBD-II self-diagnostic item.
- Diagnostic trouble code "P1705" with CONSULT or 15th judgment flicker without CONSULT is detected when TCM does not receive the proper accelerator pedal position signals (input by CAN communication) from ECM.

### Possible Cause

INFOID:000000009885794

Harness or connectors  
(The sensor circuit is open or shorted.)

### DTC Confirmation Procedure

INFOID:000000009885795

#### NOTE:

If "DTC Confirmation Procedure" has been previously performed, always turn ignition switch "OFF" and wait at least 10 seconds before performing the next test.

After the repair, perform the following procedure to confirm the malfunction is eliminated.

#### Ⓟ WITH CONSULT

1. Turn ignition switch "ON". (Do not start engine.)
2. Select "DATA MONITOR" mode for "TRANSMISSION" with CONSULT.
3. Start engine and let it idle for 1 second.
4. If DTC is detected, go to [TM-79, "Diagnosis Procedure"](#).

### Diagnosis Procedure

INFOID:000000009885796

#### 1. CHECK CAN COMMUNICATION LINE

Perform the self-diagnosis. Refer to [TM-38, "CONSULT Function \(TRANSMISSION\)"](#).

Is a malfunction in the CAN communication indicated in the results?

YES >> Check CAN communication line. Refer to [TM-48](#).

NO >> GO TO 2.

#### 2. CHECK DTC WITH TCM

##### Ⓟ With CONSULT

1. Turn ignition switch "ON". (Do not start engine.)
2. Select "ECU INPUT SIGNALS" in "DATA MONITOR" mode for "TRANSMISSION" with CONSULT.
3. Depress accelerator pedal and read out the value of "ACCELE POSI".

Item name	Condition	Display value (Approx.)
ACCELE POSI	Released accelerator pedal.	0.0/8
	Fully depressed accelerator pedal.	8/8

4. Select "SELF-DIAG RESULTS" mode for "TRANSMISSION" with CONSULT. Refer to [TM-38, "CONSULT Function \(TRANSMISSION\)"](#).

# P1705 TP SENSOR

< DTC/CIRCUIT DIAGNOSIS >

---

OK or NG

- OK >> GO TO 4.
- NG >> GO TO 3.

## 3. CHECK DTC WITH ECM

---

Ⓟ **With CONSULT**

1. Turn ignition switch "ON". (Do not start engine.)
2. Select "SELF-DIAG RESULTS" mode for "ENGINE" with CONSULT. Refer to [TM-38, "CONSULT Function \(TRANSMISSION\)"](#).

OK or NG

- OK >> GO TO 4.
- NG >> Check the DTC detected item. Refer to [TM-123, "DTC No. Index"](#).
  - If CAN communication line is detected, go to [TM-48, "Diagnosis Procedure"](#).

## 4. CHECK DTC

---

Perform "DTC Confirmation Procedure".

- Refer to [TM-79, "DTC Confirmation Procedure"](#).

OK or NG

- OK >> **INSPECTION END**
- NG >> GO TO 5.

## 5. CHECK TCM POWER SUPPLY AND GROUND CIRCUIT

---

Check TCM power supply and ground circuit. Refer to [TM-105, "Diagnosis Procedure"](#).

OK or NG

- OK >> GO TO 6.
- NG >> Repair or replace damaged parts.

## 6. DETECT MALFUNCTIONING ITEM

---

Check the following items:

- The A/T assembly harness connector pin terminals for damage or loose connection with harness connector.

OK or NG

- OK >> Replace the control valve with TCM. Refer to [TM-201, "Control Valve with TCM"](#).
- NG >> Repair or replace damaged parts.



# P1710 TRANSMISSION FLUID TEMPERATURE SENSOR

< DTC/CIRCUIT DIAGNOSIS >

## P1710 TRANSMISSION FLUID TEMPERATURE SENSOR

### Description

INFOID:000000009885797

The A/T fluid temperature sensor detects the A/T fluid temperature and sends a signal to the TCM.

### CONSULT Reference Value in Data Monitor Mode

INFOID:000000009885798

Item name	Condition °C (°F)	Display value (Approx.)
ATF TEMP SE 1	0 (32) - 20 (68) - 80 (176)	3.3 - 2.7 - 0.9 V

### On Board Diagnosis Logic

INFOID:000000009885799

- This is an OBD-II self-diagnostic item.
- Diagnostic trouble code “P1710 (A/T), P0710 (ENGINE)” with CONSULT or 10th judgment flicker without CONSULT is detected when:
  - TCM receives an excessively low or high voltage from the sensor.
  - A/T fluid temperature does not rise to the specified temperature after driving for a certain period of time.
  - There is a certain temperature difference between A/T fluid and engine coolant. (Except for Mexico)

### Possible Cause

INFOID:000000009885800

- Harness or connectors  
(The sensor circuit is open or shorted.)
- A/T fluid temperature sensor

### DTC Confirmation Procedure

INFOID:000000009885801

#### **CAUTION:**

**Always drive vehicle at a safe speed.**

#### **NOTE:**

**If “DTC Confirmation Procedure” has been previously performed, always turn ignition switch “OFF” and wait at least 10 seconds before performing the next test.**

After the repair, perform the following procedure to confirm the malfunction is eliminated.

#### ④ WITH CONSULT

##### Confirmation procedure 1

1. Turn ignition switch “ON”. (Do not start engine.)
2. Select “DATA MONITOR” mode for “TRANSMISSION” with CONSULT.
3. Start engine and maintain the following conditions for 10 seconds or more.

**VHCL/S SE-A/T: 10 km/h (6 MPH) or more**

**ACCELE POSI: More than 1.0/8**

**SLCT LVR POSI: “D” position**

4. If DTC is detected, go to [TM-82. "Diagnosis Procedure"](#).
5. If DTC is not detected, go to “Confirmation procedure 2”.

##### Confirmation procedure 2

1. Turn ignition switch “OFF” and cool the engine.
2. Turn ignition switch “ON”. (Do not start engine.)
3. Select “ATF TEMP 1” in “DATA MONITOR” mode for “TRANSMISSION” with CONSULT.
4. Record A/T fluid temperature.
5. If A/T fluid temperature is less than 20°C (68°F), go to “Confirmation procedure 3”.
6. If A/T fluid temperature is 20°C (68°F) or more, go to “Confirmation procedure 4”. (Except for Mexico)

##### Confirmation procedure 3

1. Select “DATA MONITOR” mode for “TRANSMISSION” with CONSULT.
2. Start the engine and wait for at least 3 minutes.
3. Drive the vehicle for the total minutes specified in the Driving time column below with the following conditions satisfied.

**VHCL/S SE-A/T: 10 km/h (6 MPH) or more**

**ACCELE POSI: More than 0.5/8**

# P1710 TRANSMISSION FLUID TEMPERATURE SENSOR

< DTC/CIRCUIT DIAGNOSIS >

## SLCT LVR POSI: "D" position

A/T fluid temperature before engine start	Driving time
-40°C (-40°F) – -31°C (-23.8°F)	20 minutes or more
-30°C (-22°F) – -21°C (-5.8°F)	18 minutes or more
-20°C (-4°F) – -11°C (12.2°F)	14 minutes or more
-10°C (14°F) – -1°C (30.2°F)	11 minutes or more
0°C (32°F) – 9°C (48.2°F)	8 minutes or more
10°C (50°F) – 19°C (66.2°F)	5 minutes or more

4. If DTC is detected, go to [TM-82, "Diagnosis Procedure"](#).
5. If DTC is not detected, go to "Confirmation procedure 4". (Except for Mexico)

### Confirmation procedure 4

1. Select "ATF TEMP 1" in "DATA MONITOR" mode for "TRANSMISSION" with CONSULT.
2. Select "COOLANT TEMP/S" in "DATA MONITOR" mode for "ENGINE" with CONSULT.
3. Check temperature difference between A/T fluid and engine coolant.
4. When the temperature is calculated by subtracting the engine coolant temperature from A/T fluid temperature more than 47°C (116.6°F) or is it less than -19°C (-2.2°F), go to [TM-82, "Diagnosis Procedure"](#).

## WITH GST

### Confirmation procedure 1

- Follow the procedure "With CONSULT".

### Confirmation procedure 2

1. Turn ignition switch "OFF" and cool the engine.
2. Start the engine and wait for at least 3 minutes.
3. Drive the vehicle and maintain the following conditions for 20 minutes or more.  
**VHCL/S SE-A/T: 10 km/h (6 MPH) or more**  
**ACCELE POSI: More than 0.5/8**  
**SLCT LVR POSI: "D" position**
4. If DTC is detected, go to [TM-82, "Diagnosis Procedure"](#).
5. If DTC is not detected, go to "Confirmation procedure 3". (Except for Mexico)

### Confirmation procedure 3

1. Complete engine diagnoses P0111 and P0116.
2. After starting the engine, run the engine at idle for 5 minutes.
3. If DTC is detected, go to [TM-82, "Diagnosis Procedure"](#).

## Diagnosis Procedure

INFOID:000000009885802

### 1. CHECK A/T FLUID TEMPERATURE SENSOR SIGNAL

#### With CONSULT

1. Start engine.
2. Select "ECU INPUT SIGNALS" in "DATA MONITOR" mode for "TRANSMISSION" with CONSULT.
3. Read out the value of "ATF TEMP SE 1".

Item name	Condition °C (°F)	Display value (Approx.)
ATF TEMP SE 1	0 (32) - 20 (68) - 80 (176)	3.3 - 2.7 - 0.9 V

#### OK or NG

- OK >> GO TO 5.
- NG >> GO TO 2.

### 2. CHECK A/T FLUID TEMPERATURE SENSOR

Check A/T fluid temperature sensor. Refer to [TM-83, "Component Inspection"](#).

#### OK or NG

- OK >> GO TO 3.
- NG >> Replace the control valve with TCM. Refer to [TM-201, "Control Valve with TCM"](#).

# P1710 TRANSMISSION FLUID TEMPERATURE SENSOR

## < DTC/CIRCUIT DIAGNOSIS >

### 3. CHECK SUB-HARNESS

1. Disconnect transmission range switch connector and TCM connector.
2. Check continuity between transmission range switch connector (A) terminals and TCM connector (B) terminals.

Item	Connector	Terminal	Continuity
Transmission range switch connector	F505	6	Yes
TCM connector	F503	19	
Transmission range switch connector	F505	7	Yes
TCM connector	F503	18	

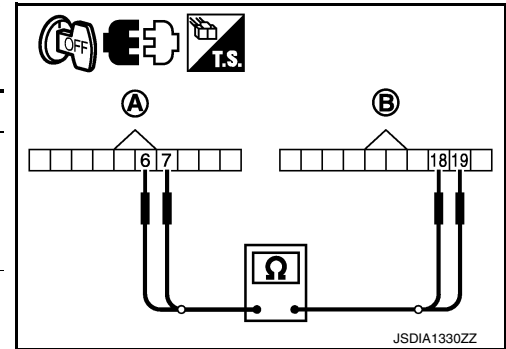

3. If OK, check harness for short to ground and short to power.

#### OK or NG

- OK >> GO TO 4.
- NG >> Replace open circuit or short to ground and short to power in harness or connectors.

### 4. CHECK TCM POWER SUPPLY AND GROUND CIRCUIT

1. Check TCM power supply and ground circuit. Refer to [TM-105. "Diagnosis Procedure"](#).
2. Reinstall any part removed.

#### OK or NG

- OK >> Replace the control valve with TCM. Refer to [TM-201. "Control Valve with TCM"](#).
- NG >> Repair or replace damaged parts.

### 5. CHECK DTC

Perform "DTC Confirmation Procedure".

- Refer to [TM-81. "DTC Confirmation Procedure"](#).

#### OK or NG

- OK >> **INSPECTION END**
- NG >> GO TO 1.

## Component Inspection

INFOID:000000009885803

### A/T FLUID TEMPERATURE SENSOR

1. Remove control valve with TCM. Refer to [TM-201. "Control Valve with TCM"](#).
2. Check resistance between transmission range switch connector terminals.

Name	Terminal	Temperature °C (°F)	Resistance (Approx.) (kΩ)
A/T fluid temperature sensor	6-7	0 (32)	15
		20 (68)	6.5
		80 (176)	0.9

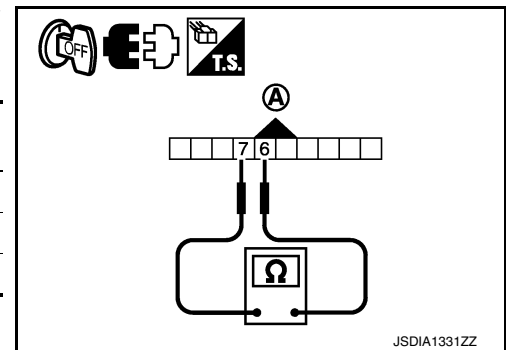

3. If NG, replace the control valve with TCM. Refer to [TM-201. "Control Valve with TCM"](#)

# P1721 VEHICLE SPEED SIGNAL

< DTC/CIRCUIT DIAGNOSIS >

## P1721 VEHICLE SPEED SIGNAL

### Description

INFOID:000000009885804

The vehicle speed signal is transmitted from combination meter to TCM by CAN communication line. The signal functions as an auxiliary device to the output speed sensor when it is malfunctioning. The TCM will then use the vehicle speed signal.

### CONSULT Reference Value in Data Monitor Mode

INFOID:000000009885805

Item name	Condition	Display value (km/h)
VHCL/S SE-MTR	During driving	Approximately matches the speedometer reading.

### On Board Diagnosis Logic

INFOID:000000009885806

- This is not an OBD-II self-diagnostic item.
- Diagnostic trouble code "P1721" with CONSULT is detected when TCM does not receive the proper vehicle speed signal (input by CAN communication) from combination meter.

### Possible Cause

INFOID:000000009885807

Harness or connectors  
(The sensor circuit is open or shorted.)

### DTC Confirmation Procedure

INFOID:000000009885808

#### **CAUTION:**

**Always drive vehicle at a safe speed.**

#### **NOTE:**

**If "DTC Confirmation Procedure" has been previously performed, always turn ignition switch "OFF" and wait at least 10 seconds before performing the next test.**

After the repair, perform the following procedure to confirm the malfunction is eliminated.

#### Ⓟ WITH CONSULT

1. Turn ignition switch "ON". (Do not start engine.)
2. Select "DATA MONITOR" mode for "TRANSMISSION" with CONSULT.
3. Start engine and maintain the following conditions for at least 5 consecutive seconds.  
**ACCELE POSI: 1.0/8 or less**  
**VHCL/S SE-MTR: 30 km/h (19 MPH) or more**
4. If DTC is detected, go to [TM-84, "Diagnosis Procedure"](#).

### Diagnosis Procedure

INFOID:000000009885809

#### 1.CHECK CAN COMMUNICATION LINE

Perform the self-diagnosis. Refer [TM-38, "CONSULT Function \(TRANSMISSION\)"](#).

Is a malfunction in the CAN communication indicated in the results?

- YES >> Check CAN communication line. Refer to [TM-48](#).  
NO >> GO TO 2.

#### 2.CHECK INPUT SIGNAL

#### Ⓟ With CONSULT

1. Start engine.
2. Select "ECU INPUT SIGNALS" in "DATA MONITOR" mode for "TRANSMISSION" with CONSULT.
3. Drive vehicle and read out the value of "VHCL/S SE-MTR".

Item name	Condition	Display value (Approx.)(km/h)
VHCL/S SE-TR	During driving	Approximately matches the speedometer reading.

#### OK or NG

- OK >> GO TO 4.

# P1721 VEHICLE SPEED SIGNAL

## < DTC/CIRCUIT DIAGNOSIS >

---

NG >> GO TO 3.

### 3.CHECK COMBINATION METERS

---

Check combination meter. Refer to [MWI-4, "Work Flow"](#).

#### OK or NG

OK >> GO TO 4.

NG >> Repair or replace damaged parts.

### 4.CHECK DTC

---

Perform "DTC Confirmation Procedure".

- Refer to [TM-84, "DTC Confirmation Procedure"](#).

#### OK or NG

OK >> **INSPECTION END**

NG >> GO TO 5.

### 5.CHECK TCM POWER SUPPLY AND GROUND CIRCUIT

---

Check TCM power supply and ground circuit. Refer to [TM-105, "Diagnosis Procedure"](#).

#### OK or NG

OK >> GO TO 6.

NG >> Repair or replace damaged parts.

### 6.DETECT MALFUNCTIONING ITEM

---

Check the following items:

- The A/T assembly harness connector pin terminals for damage or loose connection with harness connector.

#### OK or NG

OK >> Replace the control valve with TCM. Refer to [TM-201, "Control Valve with TCM"](#).

NG >> Repair or replace damaged parts.

A  
B  
C  
TM  
E  
F  
G  
H  
I  
J  
K  
L  
M  
N  
O  
P

# P1730 INTERLOCK

< DTC/CIRCUIT DIAGNOSIS >

## P1730 INTERLOCK

### Description

INFOID:000000009885810

Fail-safe function to detect interlock conditions.

### On Board Diagnosis Logic

INFOID:000000009885811

- This is an OBD-II self-diagnostic item.
- Diagnostic trouble code “P1730” with CONSULT or 12th judgment flicker without CONSULT is detected when TCM does not receive the proper voltage signal from the sensor and switch.
- TCM monitors and compares gear position and conditions of each ATF pressure switch when gear is steady.

### Possible Cause

INFOID:000000009885812

- Harness or connectors  
(The solenoid and switch circuit is open or shorted.)
- Low coast brake solenoid valve
- ATF pressure switch 2

### DTC Confirmation Procedure

INFOID:000000009885813

#### NOTE:

If “DTC Confirmation Procedure” has been previously performed, always turn ignition switch “OFF” and wait at least 10 seconds before performing the next test.

After the repair, perform the following procedure to confirm the malfunction is eliminated.

#### Ⓟ WITH CONSULT

1. Turn ignition switch “ON”. (Do not start engine.)
2. Select “DATA MONITOR” mode for “TRANSMISSION” with CONSULT.
3. Start engine.
4. Drive vehicle and maintain the following conditions for at least 2 consecutive seconds.  
**SLCT LVR POSI: “D” position**
5. If DTC is detected, go to [TM-86, "Diagnosis Procedure"](#).

#### Ⓞ WITH GST

Follow the procedure “With CONSULT”.

### Judgment of Interlock

INFOID:000000009885814

- When Interlock is judged to be malfunctioning, the vehicle should be fixed in 2GR, and should be set in a condition in which it can travel.

#### NOTE:

When the vehicle is driven fixed in 2GR, a input speed sensor malfunction is displayed, but this is not a input speed sensor malfunction.

- When interlock is detected at the 3GR or more, it is locked at the 2GR.

### Diagnosis Procedure

INFOID:000000009885815

## 1.SELF-DIAGNOSIS

#### Ⓟ With CONSULT

1. Drive vehicle.
2. Stop vehicle and turn ignition switch “OFF”.
3. Turn ignition switch “ON”.
4. Select “SELF-DIAG RESULTS” mode for “TRANSMISSION” with CONSULT.

#### OK or NG

- OK >> GO TO 2.
- NG >> Check low coast brake solenoid valve circuit and function. Refer to [TM-98, "Diagnosis Procedure"](#), [TM-101, "Diagnosis Procedure"](#).

## 2.CHECK DTC

Perform “DTC Confirmation Procedure”.

# P1730 INTERLOCK

## < DTC/CIRCUIT DIAGNOSIS >

---

- Refer to [TM-86. "DTC Confirmation Procedure"](#).

### OK or NG

- OK >> **INSPECTION END**
- NG >> GO TO 3.

## **3.**CHECK TCM POWER SUPPLY AND GROUND CIRCUIT

---

Check TCM power supply and ground circuit. Refer to [TM-105. "Diagnosis Procedure"](#).

### OK or NG

- OK >> GO TO 4.
- NG >> Repair or replace damaged parts.

## **4.**DETECT MALFUNCTIONING ITEM

---

Check the following items:

- The A/T assembly harness connector pin terminals for damage or loose connection with harness connector.

### OK or NG

- OK >> Replace the control valve with TCM. Refer to [TM-201. "Control Valve with TCM"](#).
- NG >> Repair or replace damaged parts.

A  
B  
C  
TM  
E  
F  
G  
H  
I  
J  
K  
L  
M  
N  
O  
P

# P1731 1ST ENGINE BRAKING

< DTC/CIRCUIT DIAGNOSIS >

## P1731 1ST ENGINE BRAKING

### Description

INFOID:000000009885816

Fail-safe function to prevent sudden decrease in speed by engine brake other than at "1" position.

### CONSULT Reference Value in Data Monitor Mode

INFOID:000000009885817

Item name	Condition	Display value
ON OFF SOL	Low coast brake engaged. Refer to <a href="#">TM-11</a> .	ON
	Low coast brake disengaged. Refer to <a href="#">TM-11</a> .	OFF
ATF PRES SW 2	Low coast brake engaged. Refer to <a href="#">TM-11</a> .	ON
	Low coast brake disengaged. Refer to <a href="#">TM-11</a> .	OFF

### On Board Diagnosis Logic

INFOID:000000009885818

- This is not an OBD-II self-diagnostic item.
- Diagnostic trouble code "P1731" with CONSULT or 13th judgment flicker without CONSULT is detected under the following conditions.
  - When TCM does not receive the proper voltage signal from the sensor.
  - When TCM monitors ATF pressure switch 2 and solenoid monitor value, and detects as irregular when engine brake of 1GR acts other than at 1 position.

### Possible Cause

INFOID:000000009885819

- Harness or connectors  
(The sensor circuit is open or shorted.)
- Low coast brake solenoid valve
- ATF pressure switch 2

### DTC Confirmation Procedure

INFOID:000000009885820

#### NOTE:

If "DTC Confirmation Procedure" has been previously preformed, always turn ignition switch "OFF" and wait at least 10 seconds before performing the next test.

After the repair, perform the following procedure to confirm the malfunction is eliminated.

#### ⓐ WITH CONSULT

1. Turn ignition switch "ON". (Do not start engine.)
2. Select "DATA MONITOR" mode for "TRANSMISSION" with CONSULT.
3. Start engine.
4. Drive vehicle and maintain the following conditions for at least 2 consecutive seconds.  
**ENGINE SPEED: 1,200 rpm**  
**SLCT LVR POSI: "1" position**  
**GEAR: 1st**
5. If DTC is detected, go to [TM-88. "Diagnosis Procedure"](#).

### Diagnosis Procedure

INFOID:000000009885821

#### 1. CHECK INPUT SIGNALS

#### ⓐ With CONSULT

1. Start the engine.
2. Select "SELECTION FROM MENU" in "DATA MONITOR" for "TRANSMISSION" with CONSULT
3. Drive vehicle in the "1" position (1GR), and confirm the ON/OFF actuation of "ATF PRES SW 2" and "ON OFF SOL".



# P1731 1ST ENGINE BRAKING

## < DTC/CIRCUIT DIAGNOSIS >

Item name	Condition	Display value	
ON OFF SOL	Low coast brake engaged. Refer to <a href="#">TM-11</a> .	ON	A
	Low coast brake disengaged. Refer to <a href="#">TM-11</a> .	OFF	
ATF PRES SW 2	Low coast brake engaged. Refer to <a href="#">TM-11</a> .	ON	B
	Low coast brake disengaged. Refer to <a href="#">TM-11</a> .	OFF	

### OK or NG

OK >> GO TO 4.

NG >> GO TO 2.

## 2.CHECK TCM POWER SUPPLY AND GROUND CIRCUIT

Check TCM power supply and ground circuit. Refer to [TM-105, "Diagnosis Procedure"](#).

### OK or NG

OK >> GO TO 3.

NG >> Repair or replace damaged parts.

## 3.DETECT MALFUNCTIONING ITEM

Check the following items:

- The A/T assembly harness connector pin terminals for damage or loose connection with harness connector.

### OK or NG

OK >> Replace the control valve with TCM. Refer to [TM-201, "Control Valve with TCM"](#).

NG >> Repair or replace damaged parts.

## 4.CHECK DTC

Perform "DTC Confirmation Procedure".

- Refer to [TM-88, "DTC Confirmation Procedure"](#).

### OK or NG

OK >> **INSPECTION END**

NG >> GO TO 2.

# P1752 INPUT CLUTCH SOLENOID

< DTC/CIRCUIT DIAGNOSIS >

## P1752 INPUT CLUTCH SOLENOID

### Description

INFOID:000000009885822

Input clutch solenoid valve is controlled by the TCM in response to signals sent from the transmission range switch, output speed sensor and accelerator pedal position sensor (throttle position sensor). Gears will then be shifted to the optimum position.

### CONSULT Reference Value in Data Monitor Mode

INFOID:000000009885823

Item name	Condition	Display value (Approx.)
I/C SOLENOID	Input clutch disengaged. Refer to <a href="#">TM-90</a> .	0.6 - 0.8 A
	Input clutch engaged. Refer to <a href="#">TM-90</a> .	0 - 0.05 A

### On Board Diagnosis Logic

INFOID:000000009885824

- This is an OBD-II self-diagnostic item.
- Diagnostic trouble code "P1752" with CONSULT or 5th judgment flicker without CONSULT is detected under the following conditions.
  - When TCM detects an improper voltage drop when it tries to operate the solenoid valve.
  - When TCM detects as irregular by comparing target value with monitor value.

### Possible Cause

INFOID:000000009885825

- Harness or connectors  
(The solenoid circuit is open or shorted.)
- Input clutch solenoid valve

### DTC Confirmation Procedure

INFOID:000000009885826

#### **CAUTION:**

**Always drive vehicle at a safe speed.**

#### **NOTE:**

**If "DTC Confirmation Procedure" has been previously performed, always turn ignition switch "OFF" and wait at least 10 seconds before performing the next test.**

After the repair, perform the following procedure to confirm the malfunction is eliminated.

#### WITH CONSULT

1. Turn ignition switch "ON". (Do not start engine.)
2. Select "DATA MONITOR" mode for "TRANSMISSION" with CONSULT.
3. Start engine.
4. Drive vehicle and maintain the following conditions for at least 5 consecutive seconds.
  - ACCELE POSI: 1.5/8 - 2.0/8**
  - SLCT LVR POSI: "D" position**
  - GEAR: 3rd ⇒ 4th (I/C ON/OFF)**
  - Driving location: Driving the vehicle uphill (increased engine load) will help maintain the driving conditions required for this test.**
5. If DTC is detected go to [TM-90, "Diagnosis Procedure"](#).

#### WITH GST

Follow the procedure "With CONSULT".

### Diagnosis Procedure

INFOID:000000009885827

#### 1. CHECK INPUT SIGNAL

##### With CONSULT

1. Turn ignition switch "ON".
2. Select "MAIN SIGNALS" in "DATA MONITOR" mode for "TRANSMISSION" with CONSULT.
3. Start the engine.
4. Read out the value of "I/C SOLENOID" while driving.

# P1752 INPUT CLUTCH SOLENOID

## < DTC/CIRCUIT DIAGNOSIS >

Item name	Condition	Display value (Approx.)
I/C SOLENOID	Input clutch disengaged. Refer to <a href="#">TM-90</a> .	0.6 - 0.8 A
	Input clutch engaged. Refer to <a href="#">TM-90</a> .	0 - 0.05 A

### OK or NG

OK >> GO TO 4.

NG >> GO TO 2.

## 2.CHECK TCM POWER SUPPLY AND GROUND CIRCUIT

Check TCM power supply and ground circuit. Refer to [TM-105, "Diagnosis Procedure"](#).

### OK or NG

OK >> GO TO 3.

NG >> Repair or replace damaged parts.

## 3.DETECT MALFUNCTIONING ITEM

Check the following items:

- The A/T assembly harness connector pin terminals for damage or loose connection with harness connector.

### OK or NG

OK >> Replace the control valve with TCM. Refer to [TM-201, "Control Valve with TCM"](#).

NG >> Repair or replace damaged parts.

## 4.CHECK DTC

Perform "DTC Confirmation Procedure".

- Refer to [TM-90, "DTC Confirmation Procedure"](#).

### OK or NG

OK >> **INSPECTION END**

NG >> GO TO 2.

# P1757 FRONT BRAKE SOLENOID

< DTC/CIRCUIT DIAGNOSIS >

## P1757 FRONT BRAKE SOLENOID

### Description

INFOID:000000009885828

Front brake solenoid valve is controlled by the TCM in response to signals sent from the transmission range switch, output speed sensor and accelerator pedal position sensor (throttle position sensor). Gears will then be shifted to the optimum position.

### CONSULT Reference Value in Data Monitor Mode

INFOID:000000009885829

Item name	Condition	Display value (Approx.)
FR/B SOLENOID	Front brake engaged. Refer to <a href="#">TM-92</a>	0.6 - 0.8 A
	Front brake disengaged. Refer to <a href="#">TM-92</a>	0 - 0.05 A

### On Board Diagnosis Logic

INFOID:000000009885830

- This is an OBD-II self-diagnostic item.
- Diagnostic trouble code “P1757” with CONSULT or 6th judgment flicker without CONSULT is detected under the following conditions.
  - When TCM detects an improper voltage drop when it tries to operate the solenoid valve.
  - When TCM detects as irregular by comparing target value with monitor value.

### Possible Cause

INFOID:000000009885831

- Harness or connectors  
(The solenoid circuit is open or shorted.)
- Front brake solenoid valve

### DTC Confirmation Procedure

INFOID:000000009885832

#### **CAUTION:**

**Always drive vehicle at a safe speed.**

#### **NOTE:**

**If “DTC Confirmation Procedure” has been previously performed, always turn ignition switch “OFF” and wait at least 10 seconds before performing the next test.**

After the repair, perform the following procedure to confirm the malfunction is eliminated.

#### WITH CONSULT

1. Turn ignition switch “ON”. (Do not start engine.)
2. Select “DATA MONITOR” mode for “TRANSMISSION” with CONSULT.
3. Start engine.
4. Drive vehicle and maintain the following conditions for at least 5 consecutive seconds.
  - ACCELE POSI: 1.5/8 - 2.0/8**
  - SLCT LVR POSI: “D” position**
  - GEAR: 3rd ⇒ 4th (FR/B ON/OFF)**
  - Driving location: Driving the vehicle uphill (increased engine load) will help maintain the driving conditions required for this test.**
5. If DTC is detected go to [TM-92, "Diagnosis Procedure"](#).

#### WITH GST

Follow the procedure “With CONSULT”.

### Diagnosis Procedure

INFOID:000000009885833

#### 1. CHECK INPUT SIGNAL

##### With CONSULT

1. Turn ignition switch “ON”.
2. Select “MAIN SIGNALS” in “DATA MONITOR” mode for “TRANSMISSION” with CONSULT.
3. Start engine.
4. Read out the value of “FR/B SOLENOID” while driving.

# P1757 FRONT BRAKE SOLENOID

## < DTC/CIRCUIT DIAGNOSIS >

Item name	Condition	Display value (Approx.)
FR/B SOLENOID	Front brake engaged. Refer to <a href="#">TM-92</a>	0.6 - 0.8 A
	Front brake disengaged. Refer to <a href="#">TM-92</a>	0 - 0.05 A

### OK or NG

OK >> GO TO 4.

NG >> GO TO 2.

## 2.CHECK TCM POWER SUPPLY AND GROUND CIRCUIT

Check TCM power supply and ground circuit. Refer to [TM-105, "Diagnosis Procedure"](#).

### OK or NG

OK >> GO TO 3.

NG >> Repair or replace damaged parts.

## 3.DETECT MALFUNCTIONING ITEM

Check the following items:

- The A/T assembly harness connector pin terminals for damage or loose connection with harness connector.

### OK or NG

OK >> Replace the control valve with TCM. Refer to [TM-201, "Control Valve with TCM"](#).

NG >> Repair or replace damaged parts.

## 4.CHECK DTC

Perform "DTC Confirmation Procedure".

- Refer to [TM-92, "DTC Confirmation Procedure"](#).

### OK or NG

OK >> **INSPECTION END**

NG >> GO TO 2.

# P1762 DIRECT CLUTCH SOLENOID

< DTC/CIRCUIT DIAGNOSIS >

## P1762 DIRECT CLUTCH SOLENOID

### Description

INFOID:000000009885834

Direct clutch solenoid valve is controlled by the TCM in response to signals sent from the transmission range switch, output speed sensor and accelerator pedal position sensor (throttle position sensor). Gears will then be shifted to the optimum position.

### CONSULT Reference Value in Data Monitor Mode

INFOID:000000009885835

Item name	Condition	Display value (Approx.)
D/C SOLENOID	Direct clutch disengaged. Refer to <a href="#">TM-94</a>	0.6 - 0.8 A
	Direct clutch engaged. Refer to <a href="#">TM-94</a>	0 - 0.05 A

### On Board Diagnosis Logic

INFOID:000000009885836

- This is an OBD-II self-diagnostic item.
- Diagnostic trouble code "P1762" with CONSULT or 2nd judgment flicker without CONSULT is detected under the following conditions.
  - When TCM detects an improper voltage drop when it tries to operate the solenoid valve.
  - When TCM detects as irregular by comparing target value with monitor value.

### Possible Cause

INFOID:000000009885837

- Harness or connectors  
(The solenoid circuit is open or shorted.)
- Direct clutch solenoid valve

### DTC Confirmation Procedure

INFOID:000000009885838

#### NOTE:

**If "DTC Confirmation Procedure" has been previously performed, always turn ignition switch "OFF" and wait at least 10 seconds before performing the next test.**

After the repair, perform the following procedure to confirm the malfunction is eliminated.

#### Ⓜ WITH CONSULT

1. Turn ignition switch "ON". (Do not start engine.)
2. Select "DATA MONITOR" mode for "TRANSMISSION" with CONSULT.
3. Start engine.
4. Drive vehicle and maintain the following conditions for at least 5 consecutive seconds.  
**ACCELE POSI: 1.5/8 - 2.0/8**  
**SLCT LVR POSI: "D" position**  
**GEAR: 1st ⇒ 2nd (D/C ON/OFF)**  
**Driving location: Driving the vehicle uphill (increased engine load) will help maintain the driving conditions required for this test.**
5. If DTC is detected, go to [TM-94, "Diagnosis Procedure"](#).

#### Ⓜ WITH GST

Follow the procedure "With CONSULT".

### Diagnosis Procedure

INFOID:000000009885839

#### 1. CHECK INPUT SIGNAL

##### Ⓜ With CONSULT

1. Turn ignition switch "ON".
2. Select "MAIN SIGNALS" in "DATA MONITOR" mode for "TRANSMISSION" with CONSULT.
3. Start the engine.
4. Read out the value of "D/C SOLENOID" while driving.

# P1762 DIRECT CLUTCH SOLENOID

## < DTC/CIRCUIT DIAGNOSIS >

Item name	Condition	Display value (Approx.)
D/C SOLENOID	Direct clutch disengaged. Refer to <a href="#">TM-94</a>	0.6 - 0.8 A
	Direct clutch engaged. Refer to <a href="#">TM-94</a>	0 - 0.05 A

### OK or NG

OK >> GO TO 4.

NG >> GO TO 2.

## 2.CHECK TCM POWER SUPPLY AND GROUND CIRCUIT

Check TCM power supply and ground circuit. Refer to [TM-105, "Diagnosis Procedure"](#).

### OK or NG

OK >> GO TO 3.

NG >> Repair or replace damaged parts.

## 3.DETECT MALFUNCTIONING ITEM

Check the following items:

- The A/T assembly harness connector pin terminals for damage or loose connection with harness connector.

### OK or NG

OK >> Replace the control valve with TCM. Refer to [TM-201, "Control Valve with TCM"](#).

NG >> Repair or replace damaged parts.

## 4.CHECK DTC

Perform "DTC Confirmation Procedure".

- Refer to [TM-94, "DTC Confirmation Procedure"](#).

### OK or NG

OK >> **INSPECTION END**

NG >> GO TO 2.

# P1767 HIGH AND LOW REVERSE CLUTCH SOLENOID

< DTC/CIRCUIT DIAGNOSIS >

## P1767 HIGH AND LOW REVERSE CLUTCH SOLENOID

### Description

INFOID:000000009885840

High and low reverse clutch solenoid valve is controlled by the TCM in response to signals sent from the transmission range switch, output speed sensor and accelerator pedal position sensor (throttle position sensor). Gears will then be shifted to the optimum position.

### CONSULT Reference Value in Data Monitor Mode

INFOID:000000009885841

Item name	Condition	Display value (Approx.)
HLR/C SOL	High and low reverse clutch disengaged. Refer to <a href="#">TM-96</a>	0.6 - 0.8 A
	High and low reverse clutch engaged. Refer to <a href="#">TM-96</a>	0 - 0.05 A

### On Board Diagnosis Logic

INFOID:000000009885842

- This is an OBD-II self-diagnostic item.
- Diagnostic trouble code “P1767” with CONSULT or 8th judgment flicker without CONSULT or is detected under the following conditions.
  - When TCM detects an improper voltage drop when it tries to operate the solenoid valve.
  - When TCM detects as irregular by comparing target value with monitor value.

### Possible Cause

INFOID:000000009885843

- Harness or connectors  
(The solenoid circuit is open or shorted.)
- High and low reverse clutch solenoid valve

### DTC Confirmation Procedure

INFOID:000000009885844

#### **CAUTION:**

**Always drive vehicle at a safe speed.**

#### **NOTE:**

**If “DTC Confirmation Procedure” has been previously performed, always turn ignition switch “OFF” and wait at least 10 seconds before performing the next test.**

After the repair, perform the following procedure to confirm the malfunction is eliminated.

#### WITH CONSULT

1. Turn ignition switch “ON”. (Do not start engine.)
2. Select “DATA MONITOR” mode for “TRANSMISSION” with CONSULT.
3. Start engine.
4. Drive vehicle and maintain the following conditions for at least 5 consecutive seconds.
  - ACCELE POSI: 1.5/8 - 2.0/8**
  - SLCT LVR POSI: “D” position**
  - GEAR: 2nd ⇒ 3rd (HLR/C ON/OFF)**
  - Driving location: Driving the vehicle uphill (increased engine load) will help maintain the driving conditions required for this test.**
5. If DTC is detected, go to [TM-96, "Diagnosis Procedure"](#).

#### WITH GST

Follow the procedure “With CONSULT”.

### Diagnosis Procedure

INFOID:000000009885845

#### 1. CHECK INPUT SIGNAL

##### With CONSULT

1. Turn ignition switch “ON”.
2. Select “MAIN SIGNALS” in “DATA MONITOR” mode for “TRANSMISSION” with CONSULT.
3. Start the engine.
4. Read out the value of “HLR/C SOLENOID” while driving.



# P1767 HIGH AND LOW REVERSE CLUTCH SOLENOID

## < DTC/CIRCUIT DIAGNOSIS >

Item name	Condition	Display value (Approx.)
HLR/C SOL	High and low reverse clutch disengaged. Refer to <a href="#">TM-96</a>	0.6 - 0.8 A
	High and low reverse clutch engaged. Refer to <a href="#">TM-96</a>	0 - 0.05 A

### OK or NG

OK >> GO TO 4.

NG >> GO TO 2.

## 2. CHECK TCM POWER SUPPLY AND GROUND CIRCUIT

Check TCM power supply and ground circuit Refer to [TM-105, "Diagnosis Procedure"](#).

### OK or NG

OK >> GO TO 3.

NG >> Repair or replace damaged parts.

## 3. DETECT MALFUNCTIONING ITEM

Check the following items:

- The A/T assembly harness connector pin terminals for damage or loose connection with harness connector.

### OK or NG

OK >> Replace the control valve with TCM. Refer to [TM-201, "Control Valve with TCM"](#).

NG >> Repair or replace damaged parts.

## 4. CHECK DTC

Perform "DTC Confirmation Procedure".

- Refer to [TM-96, "DTC Confirmation Procedure"](#).

### OK or NG

OK >> **INSPECTION END**

NG >> GO TO 2.

# P1772 LOW COAST BRAKE SOLENOID

< DTC/CIRCUIT DIAGNOSIS >

## P1772 LOW COAST BRAKE SOLENOID

### Description

INFOID:000000009885846

Low coast brake solenoid valve is turned “ON” or “OFF” by the TCM in response to signals sent from the transmission range switch, output speed sensor and accelerator pedal position sensor (throttle position sensor). Gears will then be shifted to the optimum position.

### CONSULT Reference Value in Data Monitor Mode

INFOID:000000009885847

Item name	Condition	Display value
ON OFF SOL	Low coast brake engaged. Refer to <a href="#">TM-98</a>	ON
	Low coast brake disengaged. Refer to <a href="#">TM-98</a>	OFF

### On Board Diagnosis Logic

INFOID:000000009885848

- This is an OBD-II self-diagnostic item.
- Diagnostic trouble code “P1772” with CONSULT or 7th judgment flicker without CONSULT is detected when TCM detects an improper voltage drop when it tries to operate the solenoid valve.

### Possible Cause

INFOID:000000009885849

- Harness or connectors  
(The solenoid circuit is open or shorted.)
- Low coast brake solenoid valve

### DTC Confirmation Procedure

INFOID:000000009885850

#### NOTE:

If “DTC Confirmation Procedure” has been previously performed, always turn ignition switch “OFF” and wait at least 10 seconds before performing the next test.

After the repair, perform the following procedure to confirm the malfunction is eliminated.

#### Ⓟ WITH CONSULT

1. Turn ignition switch “ON”. (Do not start engine.)
2. Select “DATA MONITOR” mode for “TRANSMISSION” with CONSULT.
3. Start engine.
4. Drive vehicle and maintain the following conditions for at least 5 consecutive seconds.  
Floor shift models:  
**SLCT LVR POSI: “1” or “2”**  
**GEAR: “1st” or “2nd” (LC/B ON/OFF)**

Column shift models:

**MANUAL MODE SW: ON**

**GEAR: “1st” or “2nd” (LC/B ON/OFF)**

5. If DTC is detected, go to [TM-98, "Diagnosis Procedure"](#).

#### Ⓞ WITH GST

Follow the procedure “With CONSULT”.

### Diagnosis Procedure

INFOID:000000009885851

#### 1. CHECK INPUT SIGNAL

##### Ⓟ With CONSULT

1. Turn ignition switch “ON”.
2. Select “SELECTION FROM MENU” in “DATA MONITOR” mode for “TRANSMISSION” with CONSULT.
3. Start the engine.
4. Read out the value of “ON OFF SOL” while driving.

# P1772 LOW COAST BRAKE SOLENOID

## < DTC/CIRCUIT DIAGNOSIS >

Item name	Condition	Display value
ON OFF SOL	Low coast brake engaged. Refer to <a href="#">TM-98</a>	ON
	Low coast brake disengaged. Refer to <a href="#">TM-98</a>	OFF

### OK or NG

- OK >> GO TO 4.
- NG >> GO TO 2.

## 2. CHECK TCM POWER SUPPLY AND GROUND CIRCUIT

Check TCM power supply and ground circuit. Refer to [TM-105, "Diagnosis Procedure"](#).

### OK or NG

- OK >> GO TO 3.
- NG >> Repair or replace damaged parts.

## 3. DETECT MALFUNCTIONING ITEM

Check the following items:

- The A/T assembly harness connector pin terminals for damage or loose connection with harness connector.

### OK or NG

- OK >> Replace the control valve with TCM. Refer to [TM-201, "Control Valve with TCM"](#).
- NG >> Repair or replace damaged parts.

## 4. CHECK DTC

Perform "DTC Confirmation Procedure".

- Refer to [TM-98, "DTC Confirmation Procedure"](#).

### OK or NG

- OK >> **INSPECTION END**
- NG >> GO TO 2.

A  
B  
C  
TM  
E  
F  
G  
H  
I  
J  
K  
L  
M  
N  
O  
P

# P1774 LOW COAST BRAKE SOLENOID

< DTC/CIRCUIT DIAGNOSIS >

## P1774 LOW COAST BRAKE SOLENOID

### Description

INFOID:000000009885852

- Low coast brake solenoid valve is turned “ON” or “OFF” by the TCM in response to signals sent from the transmission range switch, output speed sensor and accelerator pedal position sensor (throttle position sensor). Gears will then be shifted to the optimum position.
- This is not only caused by electrical malfunction (circuits open or shorted) but also by mechanical malfunction such as control valve sticking, improper solenoid valve operation.

### CONSULT Reference Value in Data Monitor Mode

INFOID:000000009885853

Item name	Condition	Display value
ON OFF SOL	Low coast brake engaged. Refer to <a href="#">TM-100</a>	ON
	Low coast brake disengaged. Refer to <a href="#">TM-100</a>	OFF
ATF PRES SW 2	Low coast brake engaged. Refer to <a href="#">TM-100</a>	ON
	Low coast brake disengaged. Refer to <a href="#">TM-100</a>	OFF

### On Board Diagnosis Logic

INFOID:000000009885854

- This is an OBD-II self-diagnostic item.
- Diagnostic trouble code “P1774” with CONSULT or 7th judgment flicker without CONSULT is detected under the following conditions.
  - When TCM detects that actual gear ratio is irregular, and relation between gear position and condition of ATF pressure switch 2 is irregular during depressing accelerator pedal. (Other than during shift change)
  - When TCM detects that relation between gear position and condition of ATF pressure switch 2 is irregular during releasing accelerator pedal. (Other than during shift change)

### Possible Cause

INFOID:000000009885855

- Harness or connectors  
(The solenoid and switch circuits are open or shorted.)
- Low coast brake solenoid valve
- ATF pressure switch 2

### DTC Confirmation Procedure

INFOID:000000009885856

#### **CAUTION:**

**Always drive vehicle at a safe speed.**

#### **NOTE:**

**If “DTC Confirmation Procedure” has been previously performed, always turn ignition switch “OFF” and wait at least 10 seconds before performing the next test.**

After the repair, perform the following procedure to confirm the malfunction is eliminated.

#### WITH CONSULT

1. Start engine.
2. Accelerate vehicle to maintain the following conditions.  
Floor shift models:  
**SLCT LVR POSI: “1” or “2” position**  
**GEAR: “1st” or “2nd” (LC/B ON/OFF)**  
  
Column shift models:  
**MANUAL MODE SW: ON**  
**GEAR: “1st” or “2nd” (LC/B ON/OFF)**
3. Perform step “2” again.
4. Turn ignition switch “OFF”, then perform step “1” to “3” again.
5. Check “SELF-DIAG RESULTS” mode for “TRANSMISSION” with CONSULT. If DTC (P1774) is detected, refer to [TM-101, "Diagnosis Procedure"](#).  
If DTC (P1772) is detected, go to [TM-98, "Diagnosis Procedure"](#).

# P1774 LOW COAST BRAKE SOLENOID

< DTC/CIRCUIT DIAGNOSIS >

 WITH GST

Follow the procedure "With CONSULT".

## Diagnosis Procedure

INFOID:000000009885857

### 1. CHECK INPUT SIGNALS

 With CONSULT

1. Start the engine.
2. Select "SELECTION FROM MENU" in "DATA MONITOR" mode for "TRANSMISSION" with CONSULT.
3. Drive vehicle in the "1" or "2" position ("11" or "22" gear) and confirm the ON/OFF actuation of the "ATF PRES SW 2" and "ON OFF SOL".

Item name	Condition	Display value
ON OFF SOL	Low coast brake engaged. Refer to <a href="#">TM-100</a>	ON
	Low coast brake disengaged. Refer to <a href="#">TM-100</a>	OFF
ATF PRES SW 2	Low coast brake engaged. Refer to <a href="#">TM-100</a>	ON
	Low coast brake disengaged. Refer to <a href="#">TM-100</a>	OFF

#### OK or NG

- OK >> GO TO 4.
- NG >> GO TO 2.

### 2. CHECK TCM POWER SUPPLY AND GROUND CIRCUIT

Check TCM power supply and ground circuit. Refer to [TM-105, "Diagnosis Procedure"](#).

#### OK or NG

- OK >> GO TO 3.
- NG >> Repair or replace damaged parts.

### 3. DETECT MALFUNCTIONING ITEM

Check the following items:

- The A/T assembly harness connector pin terminals for damage or loose connection with harness connector.

#### OK or NG

- OK >> Replace the control valve with TCM. Refer to [TM-201, "Control Valve with TCM"](#).
- NG >> Repair or replace damaged parts.

### 4. CHECK DTC

Perform "DTC Confirmation Procedure".

- Refer to [TM-100, "DTC Confirmation Procedure"](#).

#### OK or NG

- OK >> **INSPECTION END**
- NG >> GO TO 2.

# P1815 M-MODE SWITCH

< DTC/CIRCUIT DIAGNOSIS >

## P1815 M-MODE SWITCH

### Description

INFOID:000000009885858

When an impossible pattern of switch signals is detected, this is judged to be an irregularity.

### CONSULT Reference Value in Data Monitor Mode

INFOID:000000009885859

Item name	Condition	Display Value
MANU MODE SW	Manual shift gate position (neutral)	ON
	Other than the above	OFF
NON M-MODE SW	Manual shift gate position	OFF
	Other than the above	ON
UP SW LEVER	Select lever: + side	ON
	Other than the above	OFF
DOWN SW LEVER	Select lever: - side	ON
	Other than the above	OFF

### On Board Diagnosis Logic

INFOID:000000009885860

- This is not an OBD-II self-diagnostic item.
- Diagnostic trouble code "P1815" with CONSULT is detected when TCM monitors Manual mode, Non manual mode, Up or Down switch signal, and detects as irregular when impossible input pattern occurs 1 second or more.

### Possible Cause

INFOID:000000009885861

- Harness or connectors  
(The switch circuits are open or shorted.)
- Mode select switch (Into A/T shift selector)
- Position select switch (Into A/T shift selector)

### DTC Confirmation Procedure

INFOID:000000009885862

#### NOTE:

If "DTC Confirmation Procedure" has been previously performed, always turn ignition switch "OFF" and wait at least 10 seconds before performing the next test.

After the repair, perform the following procedure to confirm the malfunction is eliminated.

#### Ⓟ WITH CONSULT

1. Turn ignition switch ON.
2. Select "ECU INPUT SIGNALS" in "DATA MONITOR" mode for "TRANSMISSION" with CONSULT.
3. Start engine.
4. Move selector lever to "M" position.
5. Drive vehicle and maintain the following conditions for at least 2 consecutive seconds.  
**MANU MODE SW: ON**
6. If DTC is detected, go to [TM-102, "Diagnosis Procedure"](#).

### Diagnosis Procedure

INFOID:000000009885863

#### 1.CHECK CAN COMMUNICATION LINE

Perform the self-diagnosis. Is a malfunction in the CAN communication indicated in the results?

#### Yes or No

- Yes >> Check CAN communication line. Refer to [TM-48, "Description"](#).
- No >> GO TO 2.

#### 2.CHECK MANUAL MODE SWITCH CIRCUIT

# P1815 M-MODE SWITCH

## < DTC/CIRCUIT DIAGNOSIS >

Drive vehicle in the manual mode, and confirm that the actual gear position and the meter's indication of the position mutually coincide when the selector lever is shifted to the "+ (up)" or "- (down)" side (1GR ⇔ 5GR).

### OK or NG

- OK >> GO TO 6.
- NG >> GO TO 3.

## 3. DETECT MALFUNCTIONING ITEM

Check the following items.

- Manual mode switch. Refer to [TM-103, "Component Inspection"](#).
- Pin terminals for damage or loose connection with harness connector.
- Open circuit or short to ground or short to power in harness or connector for A/T shift selector (manual mode switch).

### OK or NG

- OK >> GO TO 4.
- NG >> Repair or replace damaged parts.

## 4. CHECK TCM

Perform TCM input/output signal inspection. Refer to [TM-120, "Reference Value"](#).

### OK or NG

- OK >> GO TO 6.
- NG >> GO TO 5.

## 5. DETECT MALFUNCTIONING ITEM

Check the following items:

- Power supply and ground circuit for TCM.
- The A/T assembly harness connector pin terminals for damage or loose connection with harness connector.

### OK or NG

- OK >> Replace the transmission assembly. Refer to [TM-211, "Removal and Installation \(2WD\)"](#), [TM-213, "Removal and Installation \(4WD\)"](#).
- NG >> Repair or replace damaged parts.

## 6. CHECK DTC

Perform DTC Confirmation Procedure.

- Refer to [TM-102, "DTC Confirmation Procedure"](#).

### OK or NG

- OK >> **INSPECTION END**
- NG >> GO TO 4.

## Component Inspection

INFOID:000000009885864

### MANUAL MODE SWITCH

Check continuity between A/T shift selector connector terminals.

Item	Position	Terminal No. (Unit side)	Continuity
Manual mode (select) switch	Manual	2 - 6	Yes
UP switch	UP	2 - 4	
DOWN switch	DOWN	2 - 5	

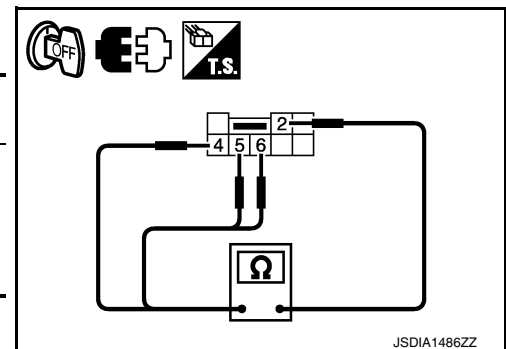

INFOID:000000009885865

## Position Indicator Lamp

## DIAGNOSTIC PROCEDURE

# P1815 M-MODE SWITCH

< DTC/CIRCUIT DIAGNOSIS >

## 1. CHECK INPUT SIGNALS (WITH CONSULT)

### With CONSULT

1. Start engine.
2. Select "MAIN SIGNALS" in "DATA MONITOR" mode for A/T with CONSULT and read out the value of "GEAR".
3. Drive vehicle in the manual mode, and confirm that the actual gear position and the meter's indication of the position mutually coincide when the select lever is shifted to the "+ (up)" or "- (down)" side (1GR ⇔ 5GR).

### OK or NG

- OK >> **INSPECTION END**  
NG >> Check the following items.

### Position Indicator Lamp Symptom Chart

Items	Presumed Location of Trouble
The actual gear position does not change, or shifting into the manual mode is not possible (no gear shifting in the manual mode possible). The position indicator lamp is not indicated.	Manual mode switch Refer to <a href="#">TM-102, "Diagnosis Procedure"</a> . A/T main system (Fail-safe function actuated) <ul style="list-style-type: none"><li>• Refer to <a href="#">GI-50, "Description"</a>.</li></ul>
The actual gear position changes, but the position indicator lamp is not indicated.	Perform the self-diagnosis function. <ul style="list-style-type: none"><li>• Refer to <a href="#">GI-50, "Description"</a>.</li></ul>
The actual gear position and the indication on the position indicator lamp do not coincide.	Perform the self-diagnosis function. <ul style="list-style-type: none"><li>• Refer to <a href="#">GI-50, "Description"</a>.</li></ul>
Only a specific position or positions is/are not indicated on the position indicator lamp.	Check the combination meter. Refer to <a href="#">MWI-19, "SHIFT POSITION INDICATOR : System Description"</a> .



# MAIN POWER SUPPLY AND GROUND CIRCUIT

< DTC/CIRCUIT DIAGNOSIS >

## MAIN POWER SUPPLY AND GROUND CIRCUIT

### Diagnosis Procedure

INFOID:00000009885866

#### 1. CHECK TCM POWER SOURCE (PART 1)

1. Turn ignition switch OFF.
2. Disconnect A/T assembly connector.
3. Check voltage between A/T assembly harness connector terminals and ground.

Item	Connector	Terminal	Voltage
A/T assembly harness connector (floor shift)	F9	1 - Ground	Battery voltage
		2 - Ground	
		6 - Ground	0 V

Item	Connector	Terminal	Voltage
A/T assembly harness connector (column shift)	F17	1 - Ground	Battery voltage
		2 - Ground	
		6 - Ground	0 V

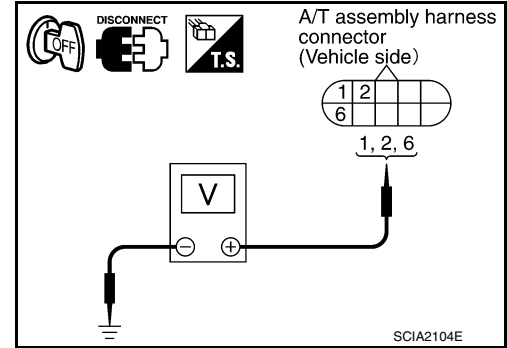

#### OK or NG

- OK >> GO TO 2.  
 NG >> GO TO 7.

#### 2. CHECK TCM POWER SOURCE (PART 2)

1. Turn ignition switch ON. (Do not start engine.)
2. Check voltage between A/T assembly harness connector terminals and ground.

Item	Connector	Terminal	Voltage
A/T assembly harness connector (floor shift)	F9	1 - Ground	Battery voltage
		2 - Ground	
		6 - Ground	0 V

Item	Connector	Terminal	Voltage
A/T assembly harness connector (column shift)	F17	1 - Ground	Battery voltage
		2 - Ground	
		6 - Ground	0 V

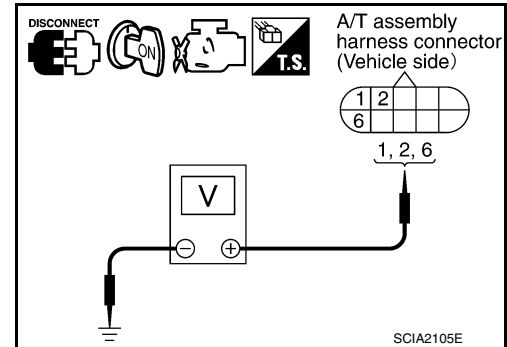

#### OK or NG

- OK >> GO TO 3.  
 NG (Floor shift)>>GO TO 8.  
 NG (Column shift)>>GO TO 9.

#### 3. CHECK TCM GROUND CIRCUIT

1. Turn ignition switch OFF.

# MAIN POWER SUPPLY AND GROUND CIRCUIT

## < DTC/CIRCUIT DIAGNOSIS >

- Check continuity between A/T assembly harness connector terminals and ground.

Item	Connector	Terminal	Continuity
A/T assembly harness connector (floor shift)	F9	5 - Ground	Yes
		10 - Ground	
Item	Connector	Terminal	Voltage
A/T assembly harness connector (column shift)	F17	5 - Ground	Yes
		10 - Ground	

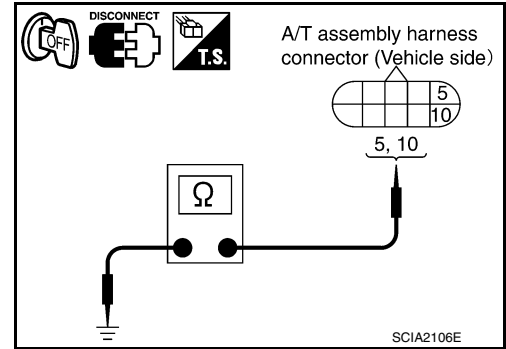

### OK or NG

- OK >> GO TO 4.
- NG >> Repair or replace damaged parts.

## 4. DETECT MALFUNCTIONING ITEM

Check the following items:

- The A/T assembly harness connector terminals for damage or loose connection with harness connector.

### OK or NG

- OK >> GO TO 5.
- NG >> Repair or replace damaged parts.

## 5. PERFORM SELF-DIAGNOSIS

Perform self-diagnosis. Refer to [TM-38, "CONSULT Function \(TRANSMISSION\)"](#).

### OK or NG

- OK >> **INSPECTION END**
- NG-1 >> Self-diagnosis does not activate: GO TO 6.
- NG-2 >> DTC is displayed: Check the malfunctioning system. Refer to [TM-38, "CONSULT Function \(TRANSMISSION\)"](#).

## 6. CHECK TERMINAL CORD ASSEMBLY

- Remove control valve with TCM. Refer to [TM-201, "Control Valve with TCM"](#).
- Disconnect A/T assembly harness connector and TCM connector.
- Check continuity between A/T assembly harness connector terminals and TCM connector terminals.

Item	Connector	Terminal	Continuity
A/T assembly harness connector (floor shift)	F9	1	Yes
A/T assembly harness connector (column shift)	F17		
TCM connector	F502	9	Yes
A/T assembly harness connector (floor shift)	F9	2	
A/T assembly harness connector (column shift)	F17		
TCM connector	F502	10	Yes
A/T assembly harness connector (floor shift)	F9	6	
A/T assembly harness connector (column shift)	F17		
TCM connector	F502	4	Yes

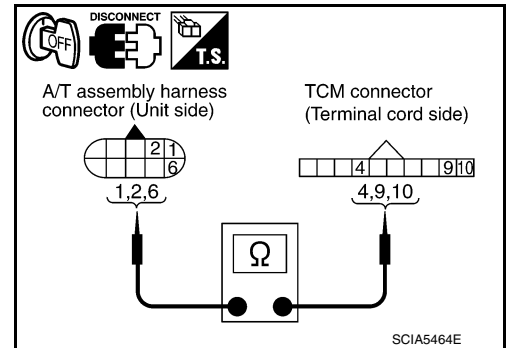

# MAIN POWER SUPPLY AND GROUND CIRCUIT

## < DTC/CIRCUIT DIAGNOSIS >

4. Check continuity between A/T assembly harness connector terminals and TCM connector terminals.

Item	Connector	Terminal	Continuity
A/T assembly harness connector (floor shift)	F9	5	Yes
A/T assembly harness connector (column shift)	F17		
TCM connector	F504	21	Yes
A/T assembly harness connector (floor shift)	F9	10	
A/T assembly harness connector (column shift)	F17		
TCM connector	F504	22	

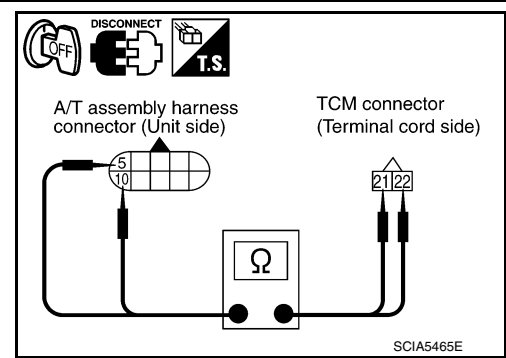

5. If OK, check harness for short to ground and short to power.

### OK or NG

- OK >> Replace the control valve with TCM. Refer to [TM-201, "Control Valve with TCM"](#).  
 NG >> Replace open circuit or short to ground and short to power in harness or connectors.

## 7. DETECT MALFUNCTIONING ITEM (STEP 1)

Check the following items:

- Harness for short or open between battery and A/T assembly harness connector terminals 1, 2
- 10A fuse [No. 3, located in the fuse block (J/B)]
- Battery

### OK or NG

- OK >> GO TO 2.  
 NG >> Repair or replace damaged parts.

## 8. DETECT MALFUNCTIONING ITEM (STEP 2)

Check the following items:

- Harness for short or open between ignition switch and A/T assembly harness connector terminal 6
- 10A fuse (No. 49, located in the IPDM E/R)
- IPDM E/R (Ignition relay)
- Ignition switch

### OK or NG

- OK >> GO TO 4.  
 NG >> Repair or replace damaged parts.

## 9. CHECK TCM (TRANSMISSION CONTROL MODULE) RELAY

1. Disconnect TCM relay.
2. Check TCM relay. Refer to [TM-108, "Component Inspection"](#).

### OK or NG

- OK >> GO TO 10.  
 NG >> Repair or replace damaged parts.

## 10. DETECT MALFUNCTIONING ITEM (STEP 3)

Check the following items:

- Harness for short or open between ignition switch and TCM relay harness connector terminal 2
- Harness for short or open between battery and TCM relay harness connector terminal 5
- Harness for open between TCM relay harness connector terminal 1 and ground
- Harness for short or open between TCM relay harness connector terminal 3 and A/T assembly harness connector terminal 6
- 10A fuse [No. 4, located in the fuse block (J/B)] and 10A fuse (No. 49, located in the IPDM E/R)
- IPDM E/R (Ignition relay)
- Ignition switch

### OK or NG

# MAIN POWER SUPPLY AND GROUND CIRCUIT

## < DTC/CIRCUIT DIAGNOSIS >

- OK >> GO TO 4.
- NG >> Repair or replace damaged parts.

### Component Inspection

INFOID:000000009885867

#### 1. TCM (TRANSMISSION CONTROL MODULE) RELAY

Check the continuity between TCM relay terminals as per the following conditions.

+	-	Conditions	Continuity
TCM relay			
Terminal			
3	5	12 V direct current supply between terminals 1 and 2	Yes
		No current supply	No

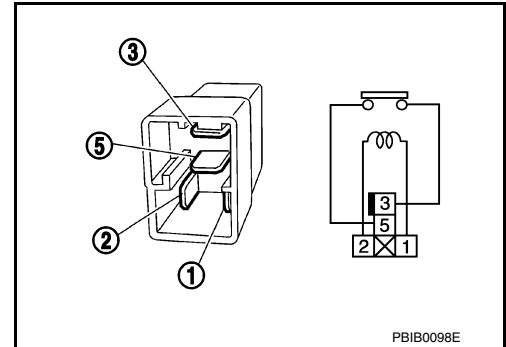

PBIB0098E

#### OK or NG

- OK >> INSPECTION END
- NG >> Replace the TCM relay.

# CLOSED THROTTLE POSITION AND WIDE OPEN THROTTLE POSITION CIRCUIT

< DTC/CIRCUIT DIAGNOSIS >

## CLOSED THROTTLE POSITION AND WIDE OPEN THROTTLE POSITION CIRCUIT

CONSULT Reference Value in Data Monitor Mode

INFOID:000000009885868

Item name	Condition	Display value
CLSD THL POS	Released accelerator pedal.	ON
	Fully depressed accelerator pedal.	OFF
W/O THL POS	Fully depressed accelerator pedal.	ON
	Released accelerator pedal.	OFF

### Diagnosis Procedure

INFOID:000000009885869

#### 1. CHECK CAN COMMUNICATION LINE

Perform the self-diagnosis. Refer to [TM-38, "CONSULT Function \(TRANSMISSION\)"](#).

Is a malfunction in the CAN communication indicated in the results?

- YES >> Check CAN communication line. Refer to [TM-48](#).  
NO >> GO TO 2.

#### 2. CHECK THROTTLE POSITION SIGNAL CIRCUIT

##### With CONSULT

- Turn ignition switch "ON". (Do not start engine.)
- Select "ECU INPUT SIGNALS" in "DATA MONITOR" mode for "TRANSMISSION" with CONSULT.
- Depress accelerator pedal and read out the value of "CLSD THL POS" and "W/O THL POS".

Accelerator Pedal Operation	Monitor Item	
	CLSD THL POS	W/O THL POS
Released	ON	OFF
Fully depressed	OFF	ON

##### OK or NG

- OK >> **INSPECTION END**  
NG >> Check the following items. If NG, repair or replace damaged parts.
- Perform the self-diagnosis for "ENGINE" with CONSULT.
  - Open circuit or short to ground or short to power in harness or connectors.
  - Pin terminals for damage or loose connection with harness connector.

# BRAKE SIGNAL CIRCUIT

< DTC/CIRCUIT DIAGNOSIS >

## BRAKE SIGNAL CIRCUIT

CONSULT Reference Value in Data Monitor Mode

INFOID:000000009885870

Item name	Condition	Display value
BRAKE SW	Depressed brake pedal.	ON
	Released brake pedal.	OFF

### Diagnosis Procedure

INFOID:000000009885871

#### 1. CHECK CAN COMMUNICATION LINE

Perform the self-diagnosis. Refer to [TM-38, "CONSULT Function \(TRANSMISSION\)"](#).

Is a malfunction in the CAN communication indicated in the results?

- YES >> Check CAN communication line. Refer to [TM-48, "Diagnosis Procedure"](#).
- NO >> GO TO 2.

#### 2. CHECK STOP LAMP SWITCH CIRCUIT

##### With CONSULT

1. Turn ignition switch "ON". (Do not start engine.)
2. Select "ECU INPUT SIGNALS" in "DATA MONITOR" mode for "TRANSMISSION" with CONSULT.
3. Read out ON/OFF switching action of the "BRAKE SW".

OK or NG

- OK >> **INSPECTION END**
- NG >> • Column shift models, GO TO 3  
• Floor shift models, GO TO 4

#### 3. CHECK STOP LAMP SWITCH (COLUMN SHIFT MODELS)

Check continuity between stop lamp switch terminals 3 and 4.

Condition	Continuity
When brake pedal is depressed	Yes
When brake pedal is released	No

Check stop lamp switch after adjusting brake pedal — refer to [BR-13, "Inspection and Adjustment - Standard Pedal"](#) or [BR-14, "Inspection and Adjustment - Adjustable Pedal"](#).

OK or NG

- OK >> Check stop lamp switch circuit.
- NG >> Repair or replace stop lamp switch.

#### 4. CHECK STOP LAMP SWITCH (FLOOR SHIFT MODELS)

Check continuity between stop lamp switch terminals 1 and 2.

Condition	Continuity
When brake pedal is depressed	Yes
When brake pedal is released	No

Check stop lamp switch after adjusting brake pedal — refer to [BR-13, "Inspection and Adjustment - Standard Pedal"](#) or [BR-14, "Inspection and Adjustment - Adjustable Pedal"](#).

OK or NG

- OK >> Check stop lamp switch circuit.
- NG >> Repair or replace stop lamp switch.

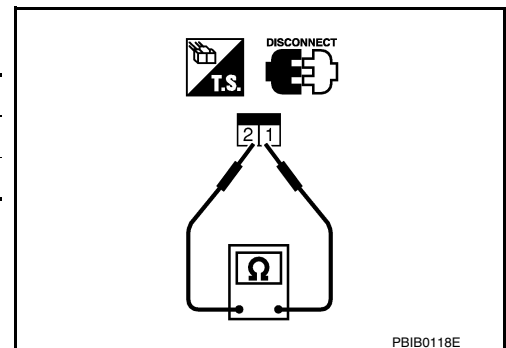
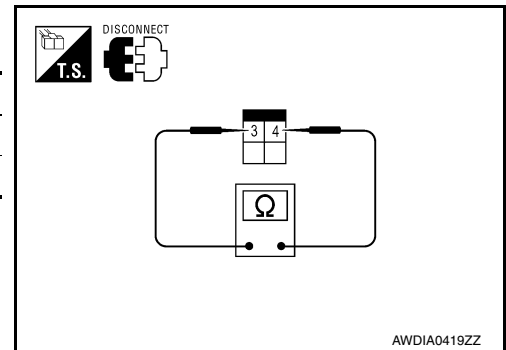

# TOW MODE SWITCH

< DTC/CIRCUIT DIAGNOSIS >

## TOW MODE SWITCH

### Description

INFOID:000000009885872

When tow mode switch is "ON", tow mode switch signals are sent to TCM from combination meter by CAN communication line. Then it's a tow mode condition.

### Diagnosis Procedure

INFOID:000000009885873

#### 1. CHECK CAN COMMUNICATION LINE

Perform the self-diagnosis. Refer to [TM-38. "CONSULT Function \(TRANSMISSION\)"](#).

Is any malfunction in the CAN communication indicated in the results?

- YES >> Check CAN communication line. Refer to [TM-48](#).
- NO >> GO TO 2.

#### 2. CHECK POWER SOURCE

1. Turn ignition switch "ON". (Do not start engine.)
2. Check the voltage between tow mode switch connector M67 terminal 1 and ground.

Condition	Tow mode switch	Data (Approx.)
When ignition switch is turned to "ON"	ON	0V
	OFF	Battery voltage

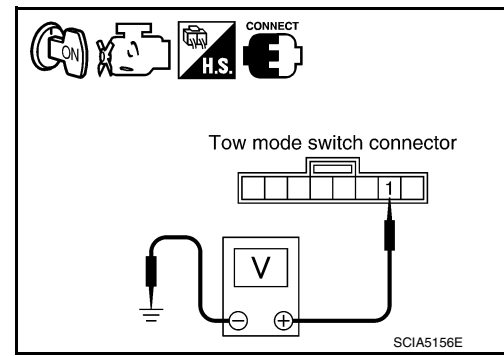

OK or NG

- OK >> **INSPECTION END**
- NG >> GO TO 3.

#### 3. CHECK TOW MODE SWITCH

1. Turn ignition switch "OFF".
2. Disconnect tow mode switch connector.
3. Check continuity between tow mode switch connector M67 terminals 1 and 2.

Condition	Continuity
Tow mode switch "ON"	Yes
Tow mode switch "OFF"	No

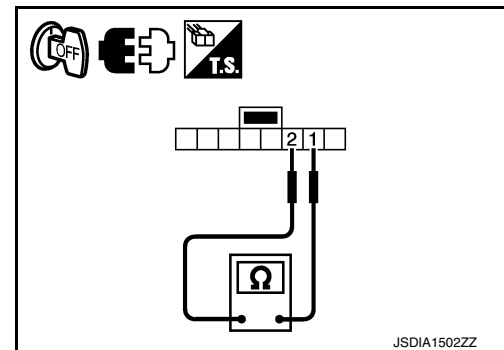

OK or NG

- OK >> GO TO 4.
- NG >> Repair or replace tow mode switch.

#### 4. DETECT MALFUNCTIONING ITEM

Check the following items. If any items are damaged, repair or replace damaged parts.

- Harness for short or open between combination meter connector terminal 35 and tow mode switch connector terminal 1.
- Harness for short or open between tow mode switch connector terminal 2 and ground.

OK or NG

- OK >> GO TO 5.
- NG >> Repair or replace damaged parts.

#### 5. CHECK COMBINATION METER

Check the combination meter. Refer to [TM-6. "Work Flow"](#).

OK or NG

- OK >> **INSPECTION END**
- NO >> Repair or replace damaged parts.

# A/T SHIFT LOCK SYSTEM

< DTC/CIRCUIT DIAGNOSIS >

## A/T SHIFT LOCK SYSTEM

### Description

INFOID:000000009885874

Refer to [TM-34, "System Description"](#).

### Terminals And Reference Values

INFOID:000000009885875

#### SHIFT LOCK HARNESS CONNECTOR TERMINALS LAYOUT (FLOOR SHIFT MODELS)

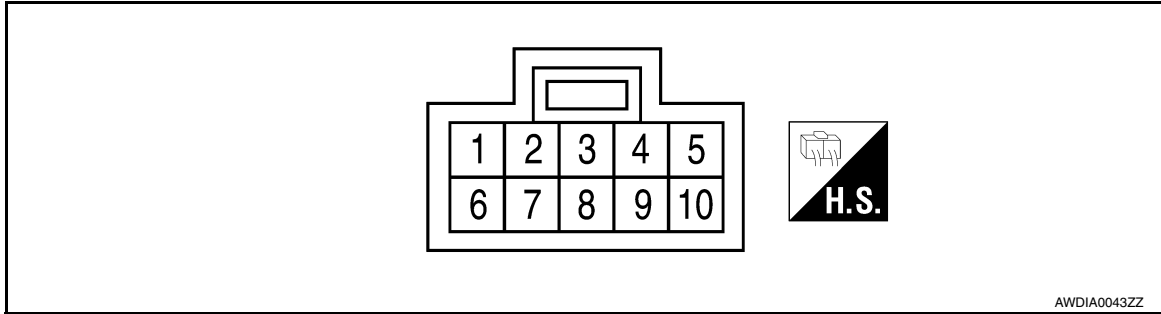

#### SHIFT LOCK CONTROL UNIT INSPECTION TABLE (FLOOR SHIFT MODELS)

Data are reference values.

TER-MINAL NO.	WIRE COLOR	ITEM	CONDITION	VOLTAGE (Approx.)
1	P	Power source	Ignition switch: "ON"	Battery voltage
			Ignition switch: "OFF"	Battery voltage
2	L/R	Park position switch (key lock)	Selector lever in "P" position	0V
			Except above with key inserted in key switch	Battery voltage
3	GR	Park position switch (shift selector)	Selector lever in "P" position	0V
			Except above	Battery voltage
4	R/G	Stop lamp switch	Brake pedal applied	Battery voltage
			Brake pedal released	0V
5	W/R	Vehicle speed signal	—	—
6	G/R	Ignition signal	Ignition switch: "ON"	Battery voltage
			Ignition switch: "OFF"	0V
7	R/W	Shift lock solenoid	Brake pedal applied with ignition switch in "ON" position	0V
			Except above	Battery voltage
8	B	Ground	—	—
9	G/W	Key lock solenoid	Selector lever in any position except "P", and ignition switch turned from "ON" to "OFF"	Battery voltage for approx. 0.1 sec. (Note)
			Except above	0V
10	W/G	Key unlock solenoid	Key inserted in ignition switch	Battery voltage for approx. 0.1 sec. (Note)
			Except the above	0V

#### NOTE:

Confirm that the pointer swings only momentarily because the output time is so short. If the inspection is done with an oscilloscope, it should be observed that the power source voltage lasts for 3.5 to 10 ms.

#### Component Inspections (Floor Shift Models)

INFOID:000000009885876

#### SHIFT LOCK SOLENOID



# A/T SHIFT LOCK SYSTEM

## < DTC/CIRCUIT DIAGNOSIS >

- Check operation by applying battery voltage to A/T shift selector terminal 9 and ground to terminal 10.

**CAUTION:**

Be sure to apply the voltage of the correct polarity to the respective terminals. Otherwise, the part may be damaged.

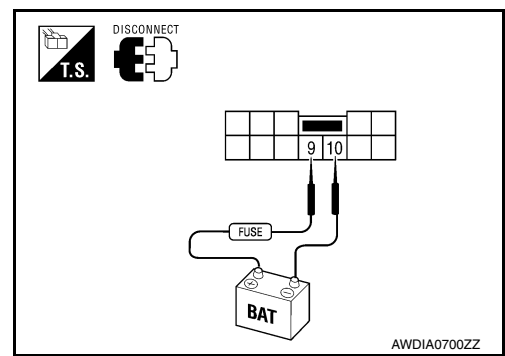

## PARK POSITION SWITCH (KEY LOCK)

- Check continuity between terminals of the A/T shift selector.

Condition	Terminal No.	Continuity
When selector lever is "P" position.	5 - 6	No
When selector lever is not "P" position.		Yes

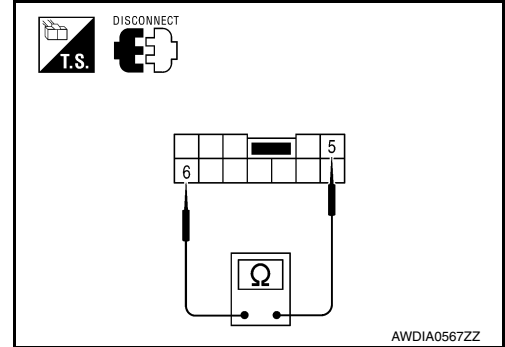

## PARK POSITION SWITCH (SHIFT SELECTOR)

- Check continuity between terminals of the A/T shift selector.

Condition	Terminal No.	Continuity
When selector lever is "P" position.	3 - 4	No
When selector lever is not "P" position.		Yes

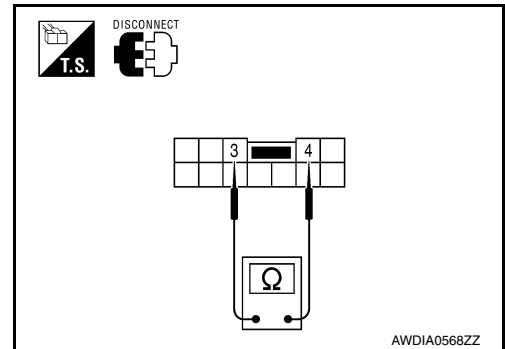

## KEY LOCK SOLENOID

### Key lock

- Check operation by applying battery voltage to key switch and key lock solenoid terminal 1 and ground to terminal 2.

**CAUTION:**

Be careful not to cause burnout of the component.

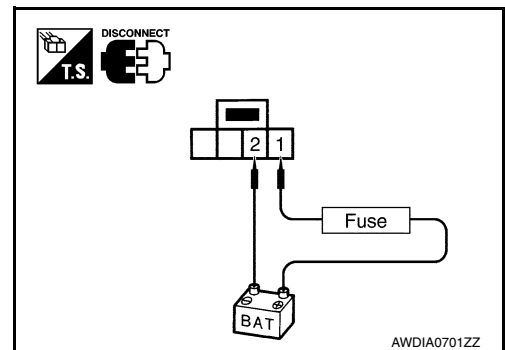

### Key unlock

A  
B  
C  
TM  
E  
F  
G  
H  
I  
J  
K  
L  
M  
N  
O  
P

# A/T SHIFT LOCK SYSTEM

## < DTC/CIRCUIT DIAGNOSIS >

- Check operation by applying battery voltage to key switch and key lock solenoid terminal 2 and ground to terminal 1.

**CAUTION:**

**Be careful not to cause burnout of the component.**

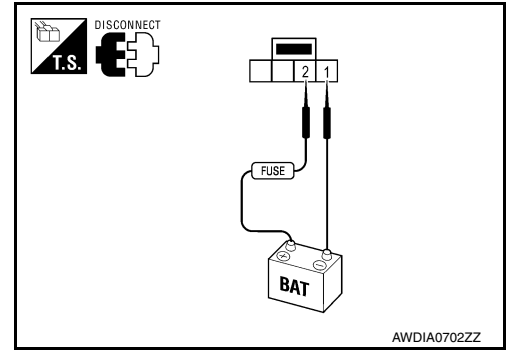

### KEY SWITCH

- Check continuity between terminals of the key switch and key lock solenoid.

Condition	Terminal No.	Continuity
Key inserted	3 - 4	Yes
Key removed		No

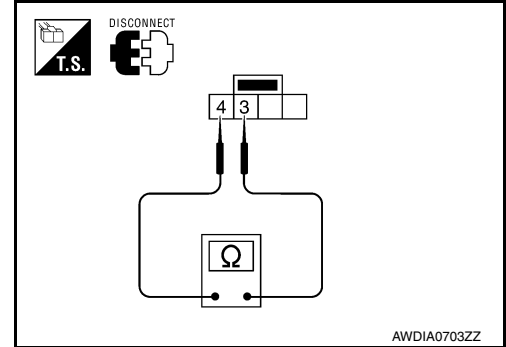

### STOP LAMP SWITCH

- Check continuity between terminals of the stop lamp switch harness connector.

Condition	Terminal No.	Continuity
When brake pedal is applied	1 - 2	Yes
When brake pedal is released		No

Check stop lamp switch after adjusting brake pedal.

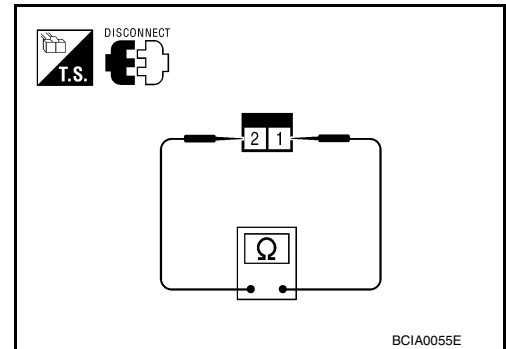

## Component Inspections (Column Shift Models)

INFOID:000000009885877

### SHIFT LOCK SOLENOID

Check operation by applying battery voltage to A/T shift selector terminal 3 and ground to terminal 1.

**CAUTION:**

**Be sure to apply the voltage of the correct polarity to the respective terminals. Otherwise, the part may be damaged.**

### PARK POSITION SWITCH (KEY LOCK)

Check continuity between terminals of the A/T shift selector.

Condition	Terminal No.	Continuity
When selector lever is "P" position.	3 - 1	No
When selector lever is not "P" position.		Yes

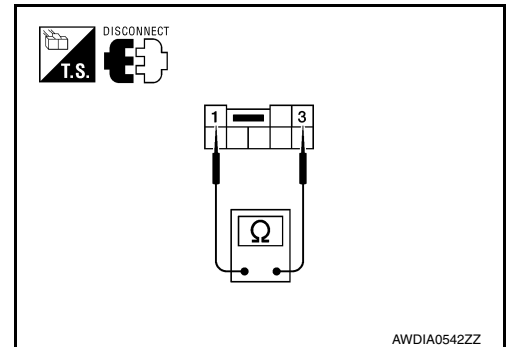

### STOP LAMP SWITCH

# A/T SHIFT LOCK SYSTEM

## < DTC/CIRCUIT DIAGNOSIS >

- Check continuity between terminals of the stop lamp switch.

Condition	Terminal No.	Continuity
When brake pedal is depressed	3 -4	Yes
When brake pedal is released		No

Check stop lamp switch after adjusting brake pedal.

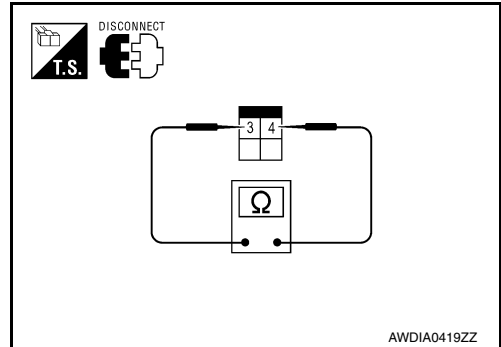

A  
B  
C

TM

E  
F  
G  
H  
I  
J  
K  
L  
M  
N  
O  
P

# 1ST POSITION SWITCH

< DTC/CIRCUIT DIAGNOSIS >

## 1ST POSITION SWITCH

CONSULT Reference Value in Data Monitor Mode

INFOID:000000009885878

Item name	Condition	Display value
1 POSITION SW	When setting selector lever to "1" position.	ON
	When setting selector lever to other positions.	OFF

### Diagnosis Procedure

INFOID:000000009885879

#### 1. CHECK CAN COMMUNICATION LINE

Perform the self-diagnosis. Refer to [TM-38. "CONSULT Function \(TRANSMISSION\)"](#).

Is any malfunction in the CAN communication indicated in the results?

- YES >> Check CAN communication line. Refer to [TM-48](#).
- NO >> GO TO 2.

#### 2. CHECK 1ST POSITION SWITCH CIRCUIT

##### With CONSULT

1. Turn ignition switch "ON".
2. Select "ECU INPUT SIGNALS" in "DATA MONITOR" mode for "TRANSMISSION" with CONSULT.
3. Read out "1 POSITION SW".  
Check the signal of the 1st position switch is indicated properly.

Monitor item	Condition	Display value
1 POSITION SW	When setting selector lever to "1" position.	ON
	When setting selector lever to other positions.	OFF

##### Without CONSULT

1. Turn ignition switch "ON". (Do not start engine)
2. Check voltage between A/T shift selector connector terminal and ground.

Item	Connector	Terminal	Condition	Data (Approx.)
1st position switch	M203	7 - Ground	When setting selector lever to "1" position.	0V
			When setting selector lever to other positions.	Battery voltage

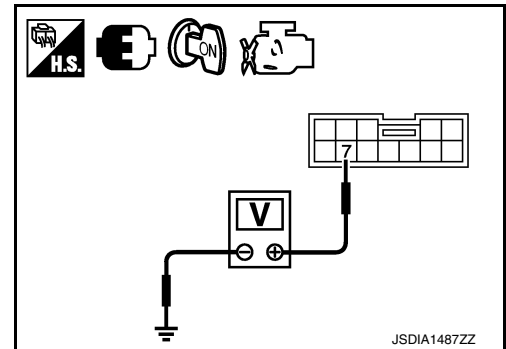

##### OK or NG

- OK >> GO TO 5.
- NG >> GO TO 3.

#### 3. CHECK 1ST POSITION SWITCH

1. Turn ignition switch "OFF".
2. Disconnect A/T shift selector connector.

# 1ST POSITION SWITCH

## < DTC/CIRCUIT DIAGNOSIS >

3. Check continuity between A/T shift selector connector terminals.

Item	Connector	Terminal	Condition	Continuity
1st position switch	M203	7 - 8	When setting selector lever to "1" position.	Yes
			When setting selector lever to other positions.	No

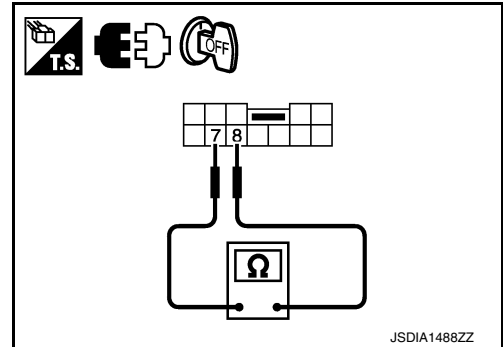

### OK or NG

OK >> GO TO 4.

NG >> Repair or replace A/T shift selector assembly.

## 4. DETECT MALFUNCTIONING ITEM

Check the following. If any items are damaged, repair or replace damaged parts.

- Harness for short or open between combination meter connector terminal 4 and A/T shift selector connector terminal 7.
- Harness for short or open between A/T shift selector connector terminal 8 and ground.

### OK or NG

OK >> GO TO 5.

NG >> Repair or replace damaged parts.

## 5. CHECK COMBINATION METER

Check the combination meter. Refer to [MWI-27, "Diagnosis Description"](#).

### OK or NG

OK >> **INSPECTION END**

NO >> Repair or replace damaged parts.

# 4TH POSITION SWITCH

< DTC/CIRCUIT DIAGNOSIS >

## 4TH POSITION SWITCH

CONSULT Reference Value in Data Monitor Mode

INFOID:000000009885880

Item name	Condition	Display value
OD CONT SW	Releasing overdrive control switch	OFF
	Holding overdrive control switch	ON

### Diagnosis Procedure

INFOID:000000009885881

#### 1. CHECK CAN COMMUNICATION LINE

Perform the self-diagnosis. Refer to [TM-38. "CONSULT Function \(TRANSMISSION\)"](#).

Is any malfunction in the CAN communication indicated in the results?

- YES >> Check CAN communication line. Refer to [TM-48](#).
- NO >> GO TO 2.

#### 2. CHECK 4TH POSITION SWITCH CIRCUIT

##### With CONSULT

1. Turn ignition switch "ON".
2. Select "ECU INPUT SIGNALS" in "DATA MONITOR" mode for "TRANSMISSION" with CONSULT.
3. Read out "OD CONT SW".  
Check the signal of the overdrive control switch is indicated properly.

Monitor item	Condition	Display value
OD CONT SW	When setting the selector lever to "4" and "3" positions.	ON
	When setting the selector lever to other positions.	OFF

##### Without CONSULT

1. Turn ignition switch "ON". (Do not start engine)
2. Check voltage between A/T shift selector connector terminal and ground.

Item	Connector	Terminal	Condition	Data (Approx.)
4th position switch	M203	1 - Ground	When setting the selector lever to "4" and "3" positions.	0V
			When setting the selector lever to other positions.	Battery voltage

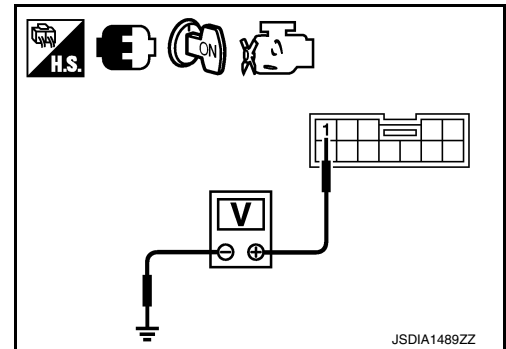

##### OK or NG

- OK >> GO TO 5.
- NG >> GO TO 3.

#### 3. CHECK 4TH POSITION SWITCH

1. Turn ignition switch "OFF".
2. Disconnect A/T shift selector connector.

## 4TH POSITION SWITCH

### < DTC/CIRCUIT DIAGNOSIS >

3. Check continuity between A/T shift selector connector terminals.

Item	Connector	Terminal	Condition	Continuity
4th position switch	M203	1 - 2	When setting the selector lever to "4" and "3" positions.	Yes
			When setting the selector lever to other positions.	No

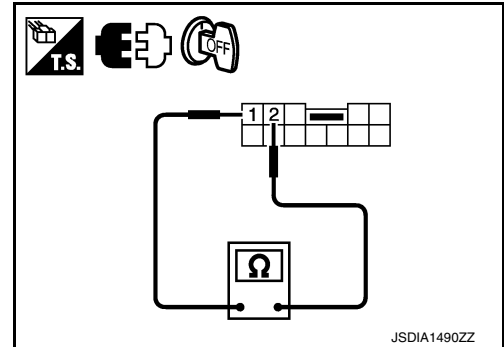

#### OK or NG

OK >> GO TO 4.

NG >> Repair or replace overdrive control switch.

### 4. DETECT MALFUNCTIONING ITEM

Check the following. If any items are damaged, repair or replace damaged parts.

- Harness for short or open between combination meter connector terminal 5 and A/T shift selector connector terminal 1.
- Harness for short or open between A/T shift selector connector terminal 2 and ground.

#### OK or NG

OK >> GO TO 5.

NG >> Repair or replace damaged parts.

### 5. CHECK COMBINATION METER

Check the combination meter. Refer to [MWI-27, "Diagnosis Description"](#).

#### OK or NG

OK >> **INSPECTION END**

NO >> Repair or replace damaged parts.

# TCM

< ECU DIAGNOSIS INFORMATION >

## ECU DIAGNOSIS INFORMATION

### TCM

#### Reference Value

INFOID:000000009885882

#### REFERENCE VALUES

##### NOTICE:

- The CONSULT electrically displays shift timing and lock-up timing (that is, operation timing of each solenoid).  
Check for time difference between actual shift timing and the CONSULT display. If the difference is noticeable, mechanical parts (except solenoids, sensors, etc.) may be malfunctioning. Check mechanical parts using applicable diagnostic procedures.
- Shift schedule (which implies gear position) displayed on CONSULT and that indicated in Service Manual may differ slightly. This occurs because of the following reasons:
  - Actual shift schedule has more or less tolerance or allowance,
  - Shift schedule indicated in Service Manual refers to the point where shifts start, and
  - Gear position displayed on CONSULT indicates the point where shifts are completed.
- Display of solenoid valves on CONSULT changes at the start of shifting, while gear position is displayed upon completion of shifting (which is computed by TCM).

Item name	Condition	Display value (Approx.)
ATF TEMP SE 1	0°C (32° F) - 20°C (68°F) - 80°C (176°F)	3.3 - 2.7 - 0.9 V
TCC SOLENOID	When perform slip lock-up	0.2 - 0.4 A
	When perform lock-up	0.4 - 0.6 A
SLCT LVR POSI	Selector lever in "N", "P" position.	N/P
	Selector lever in "R" position.	R
	Selector lever in "D" position.	D
	Selector lever in "4" position.	4
	Selector lever in "3" position.	3
	Selector lever in "2" position.	2
	Selector lever in "1" position.	1
VHCL/S SE·A/T	During driving	Approximately matches the speedometer reading.
ENGINE SPEED	Engine running	Closely matches the tachometer reading.
LINE PRES SOL	During driving	0.2 - 0.6 A
INPUT SPEED	During driving (lock-up ON)	Approximately matches the engine speed.
VHCL/S SE·MTR	During driving	Approximately matches the speedometer reading.
ATF PRES SW 2	Low coast brake engaged. Refer to <a href="#">TM-11</a>	ON
	Low coast brake disengaged. Refer to <a href="#">TM-11</a>	OFF
I/C SOLENOID	Input clutch disengaged. Refer to <a href="#">TM-11</a>	0.6 - 0.8 A
	Input clutch engaged. Refer to <a href="#">TM-11</a>	0 - 0.05 A
FR/B SOLENOID	Front brake engaged. Refer to <a href="#">TM-11</a>	0.6 - 0.8 A
	Front brake disengaged. Refer to <a href="#">TM-11</a>	0 - 0.05 A
D/C SOLENOID	Direct clutch disengaged. Refer to <a href="#">TM-11</a>	0.6 - 0.8 A
	Direct clutch engaged. Refer to <a href="#">TM-11</a>	0 - 0.05 A
HLR/C SOL	High and low reverse clutch disengaged. Refer to <a href="#">TM-11</a>	0.6 - 0.8 A
	High and low reverse clutch engaged. Refer to <a href="#">TM-11</a>	0 - 0.05 A



# TCM

## < ECU DIAGNOSIS INFORMATION >

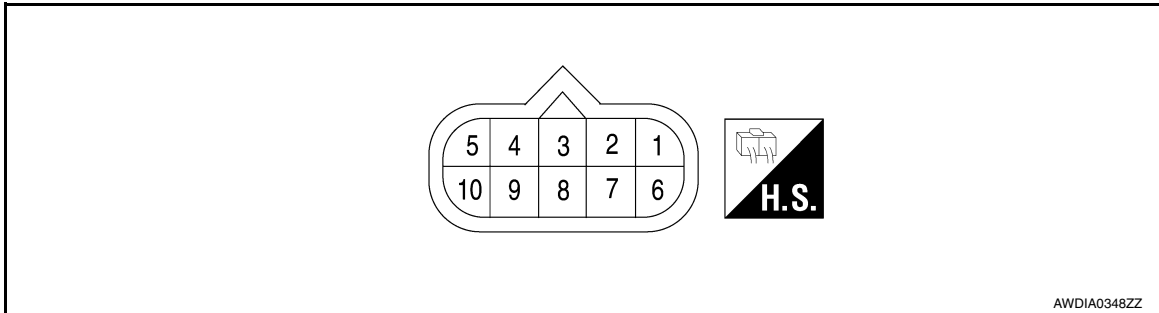

Item name	Condition	Display value (Approx.)
ON OFF SOL	Low coast brake engaged. Refer to <a href="#">TM-11</a>	ON
	Low coast brake disengaged. Refer to <a href="#">TM-11</a>	OFF
STARTER RELAY	Selector lever in "N","P" position.	ON
	Selector lever in other position.	OFF
ACCELE POSI	Released accelerator pedal.	0.0/8
	Fully depressed accelerator pedal.	8/8
CLSD THL POS	Released accelerator pedal.	ON
	Fully depressed accelerator pedal.	OFF
W/O THL POS	Fully depressed accelerator pedal.	ON
	Released accelerator pedal.	OFF
BRAKESW	Depressed brake pedal.	ON
	Released brake pedal.	OFF
OD CONT SW	When setting the selector lever to "4" and "3" positions.	ON
	When setting the selector lever to other positions.	OFF
1 POSITION SW	When setting the selector lever to "1" position.	ON
	When setting the selector lever to other positions.	OFF

## TERMINAL LAYOUT



## PHYSICAL VALUES

Data are reference value and are measured between each terminal and ground.

Terminal No.	Wire color	Item	Condition	Data (Pyrex.)
1	P	Power supply (Memory back-up)	Always	Battery voltage
2	P	Power supply (Memory back-up)	Always	Battery voltage
3	L	CAN-H	-	-
4	G/W	K-line (CONSULT signal)	The terminal is connected to the data link connector for CONSULT.	-
5	B	Ground	Always	0V
6	Y/R	Power supply	 -	Battery voltage
			 -	0V
7	R	Back-up lamp relay	 Selector lever in "R" position.	0V
			Selector lever in other positions.	Battery voltage
8	P	CAN-L	-	-

# TCM

## < ECU DIAGNOSIS INFORMATION >

Terminal No.	Wire color	Item	Condition	Data (Pyrex.)
9	B/R	Starter relay	 Selector lever in "N", "P" positions.	Battery voltage
			Selector lever in other positions.	0V
10	B	Ground	Always	0V

### Fail-Safe

INFOID:000000009885883

The TCM has an electrical fail-safe mode. This mode makes it possible to operate even if there is an error in a main electronic control input/output signal circuit.

The TCM has an electrical fail-safe mode. This mode makes it possible to operate even if there is an error in a main electronic control input/output signal circuit. In fail-safe mode the transmission is fixed in 2nd, 4th or 5th (depending on the breakdown position), so the customer should feel "slipping" or "poor acceleration".

Even when the electronic circuits are normal, under special conditions (for example, when slamming on the brake with the wheels spinning drastically and stopping the tire rotation), the transmission can go into fail-safe mode. If this happens, switch "OFF" the ignition switch for 10 seconds, then switch it "ON" again to return to the normal shift pattern. Therefore, the customer's vehicle has returned to normal, so handle according to the "diagnostics flow" (Refer to [TM-6, "Work Flow"](#)).

### FAIL-SAFE FUNCTION

If any malfunction occurs in a sensor or solenoid, this function controls the A/T to mark driving possible.

#### Output Speed Sensor

- Signals are input from two systems - from output speed sensor installed on the transmission and from combination meter so normal driving is possible even if there is a malfunction in one of the systems. And if output speed sensor has unusual cases, 5GR is prohibited.

#### Accelerator Pedal Position Sensor

- If there is a malfunction in one of the systems, the accelerator opening angle is controlled by ECM according to a pre-determined accelerator angle to make driving possible. And if there are malfunctions in tow systems, the engine speed is fixed by ECM to a pre-determined engine speed to make driving possible.

#### Throttle Position Sensor

- If there is a malfunction in one of the systems, the accelerator opening angle is controlled by ECM according to a pre-determined accelerator angle to make driving possible. And if there are malfunctions in tow systems, the accelerator opening angle is controlled by the idle signal sent from the ECM which is based on input indicating either idle condition or off-idle condition (pre-determined accelerator opening) in order to make driving possible.

#### Transmission Range Switch

- In the unlikely event that a malfunction signal enters the TCM, the position indicator is switched "OFF", the starter relay is switched "OFF" (starter starting is disabled), the back-up lamp relay switched "OFF" (back-up lamp is OFF) and the position is fixed to the "D" range to make driving possible.

#### Starter Relay

- The starter relay is switched "OFF". (Starter starting is disabled.)

#### Interlock

- If there is an interlock judgment malfunction, the transmission is fixed in 2GR to make driving possible.

#### NOTE:

**When the vehicle is driven fixed in 2GR, a input speed sensor malfunction is displayed, but this is not a input speed sensor malfunction.**

- When the interlock is detected at the 3GR or more, it is locked at the 2GR.

#### 1st Engine Braking

- When there is an 1st engine brake judgment malfunction, the low coast brake solenoid is switched "OFF" to avoid the engine brake operation.

#### Line Pressure Solenoid

- The solenoid is switched "OFF" and the line pressure is set to the maximum hydraulic pressure to make driving possible.

#### Torque Converter Clutch Solenoid

- The solenoid is switched "OFF" to release the lock-up.

# TCM

## < ECU DIAGNOSIS INFORMATION >

### Low Coast Brake Solenoid

- When a (electrical or functional) malfunction occurs, in order to make driving possible, the engine brake is not applied in 1GR and 2GR. A

### Input Clutch Solenoid

- If a (electrical or functional) malfunction occurs with the solenoid either "ON" or "OFF", the transmission is held in 4GR to make driving possible. B

### Direct Clutch Solenoid

- If a (electrical or functional) malfunction occurs with the solenoid either "ON" or "OFF", the transmission is held in 4GR to make driving possible. C

### Front Brake Solenoid

- If a (electrical or functional) malfunction occurs with the solenoid "ON", in order to make driving possible, the A/T is held in 5GR; if the solenoid is OFF, 4GR. TM

### High and Low Reverse Clutch Solenoid

- If a (electrical or functional) malfunction occurs with the solenoid either "ON" or "OFF", the transmission is held in 4GR to make driving possible. E

### Input Speed Sensor 1 or 2

- The control is the same as if there were no input speed sensors, 5GR is prohibited. F

## DTC Inspection Priority Chart

INFOID:000000009885884

If some DTCs are displayed at the same time, perform inspections one by one based on the following priority chart. G

### NOTE:

**If DTC U0100/U1000 is displayed with other DTCs, first perform the trouble diagnosis for DTC U0100/U1000. Refer to [TM-47, "Diagnosis Procedure"](#) (U0100), [TM-48, "Diagnosis Procedure"](#) (U1000).** H

Priority	Detected items (DTC)
1	<ul style="list-style-type: none"> <li>• U0100 LOST COMM (ECM A)</li> <li>• U1000 CAN COMM CIRCUIT</li> </ul>
2	Except above <span style="float: right;">I</span>

## DTC No. Index

INFOID:000000009885885

### NOTE:

**If DTC U1000 is displayed with other DTC, first perform the trouble diagnosis for DTC U1000. Refer to [TM-48, "Diagnosis Procedure"](#).** K

DTC		Items (CONSULT screen terms)	Reference page
OBD- II	Except OBD- II		
"ENGINE" with CONSULT or GST (*1)	CONSULT only "TRANSMISSION"		
—	P0615	STARTER RELAY	<a href="#">TM-49</a>
P0700	P0700	TRANSMISSION CONT	<a href="#">TM-52</a>
P0705	P0705	T/M RANGE SWITCH A	<a href="#">TM-53</a>
P0710	P1710	TRANS FLUID TEMP SEN	<a href="#">TM-82</a>
P0717	P0717	INPUT SPEED SENSOR A	<a href="#">TM-56</a>
P0720	P0720	OUTPUT SPEED SENSOR	<a href="#">TM-59</a>
—	P0725	ENGINE SPEED	<a href="#">TM-61</a>
P0731	P0731	1GR INCORRECT RATIO	<a href="#">TM-64</a>
P0732	P0732	2GR INCORRECT RATIO	<a href="#">TM-66</a>
P0733	P0733	3GR INCORRECT RATIO	<a href="#">TM-68</a>
P0734	P0734	4GR INCORRECT RATIO	<a href="#">TM-70</a>
P0735	P0735	5GR INCORRECT RATIO	<a href="#">TM-72</a>

# TCM

## < ECU DIAGNOSIS INFORMATION >

DTC		Items (CONSULT screen terms)	Reference page
OBD- II	Except OBD- II		
"ENGINE" with CONSULT or GST (*1)	CONSULT only "TRANSMISSION"		
P0740	P0740	TORQUE CONVERTER	<a href="#">TM-73</a>
P0744	P0744	TORQUE CONVERTER	<a href="#">TM-75</a>
P0745	P0745	PC SOLENOID A	<a href="#">TM-77</a>
—	P1705	TP SENSOR	<a href="#">TM-79</a>
—	P1721	VEHICLE SPEED SIGNAL	<a href="#">TM-84</a>
P1730	P1730	INTERLOCK	<a href="#">TM-86</a>
—	P1731	1GR E/BRAKING	<a href="#">TM-88</a>
P1752	P1752	INPUT CLUTCH SOL	<a href="#">TM-90</a>
P1757	P1757	FR BRAKE SOLENOID	<a href="#">TM-92</a>
P1762	P1762	DRCT CLUTCH SOL	<a href="#">TM-94</a>
P1767	P1767	HLR CLUTCH SOLENOID	<a href="#">TM-96</a>
P1772	P1772	L C BRAKE SOLENOID	<a href="#">TM-98</a>
P1774 (2*)	P1774	L C BRAKE SOLENOID	<a href="#">TM-101</a>
—	P1815	M-MODE SWITCH	<a href="#">TM-102</a>
U0100	U0100	LOST COMM (ECM A)	<a href="#">TM-47</a>
U1000	U1000	CAN COMM CIRCUIT	<a href="#">TM-48</a>

\*1: These numbers are prescribed by SAE J2012.

\*2: These malfunctions cannot be displayed MIL if another malfunction is assigned to MIL.

# A/T CONTROL SYSTEM

< WIRING DIAGRAM >

## WIRING DIAGRAM

### A/T CONTROL SYSTEM

#### Wiring Diagram

INFOID:000000009885886

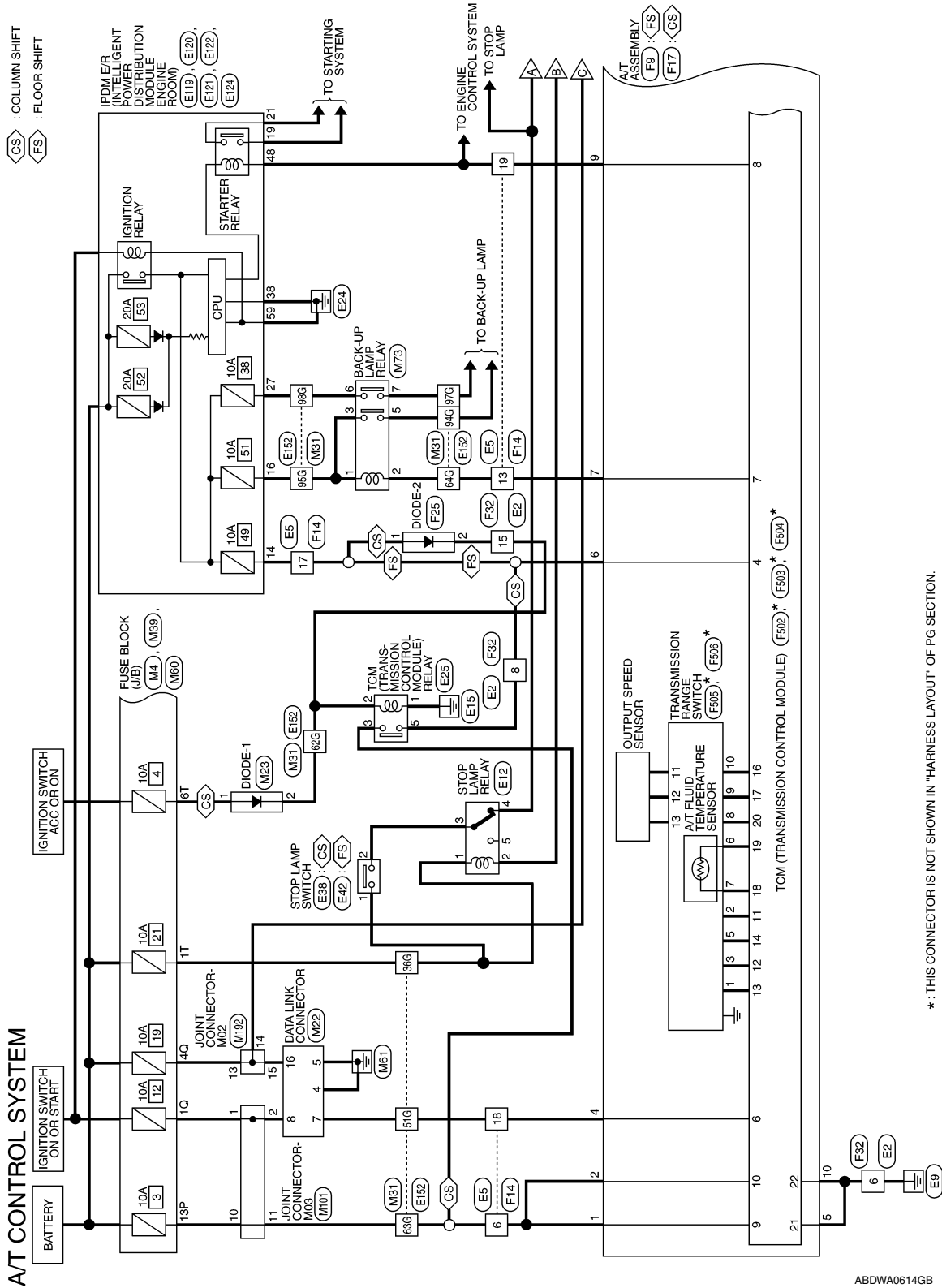

\*: THIS CONNECTOR IS NOT SHOWN IN "HARNES LAYOUT" OF PG SECTION.

ABDWA0614GB

A  
B  
C  
TM  
E  
F  
G  
H  
I  
J  
K  
L  
M  
N  
O  
P



# A/T CONTROL SYSTEM

< WIRING DIAGRAM >

## A/T CONTROL SYSTEM CONNECTORS

Connector No.	M4
Connector Name	FUSE BLOCK (J/B)
Connector Color	WHITE



Terminal No.	Color of Wire	Signal Name
5P	O/L	-
13P	P	-

Connector No.	M22
Connector Name	DATA LINK CONNECTOR
Connector Color	WHITE

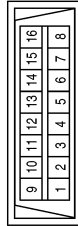

Terminal No.	Color of Wire	Signal Name
4	B	-
5	B	-
7	G/W	-
8	G/R	-
16	Y/R	-

Connector No.	M23
Connector Name	DIODE-1
Connector Color	WHITE



Terminal No.	Color of Wire	Signal Name
1	O	-
2	BR	-

Connector No.	M24
Connector Name	COMBINATION METER
Connector Color	WHITE

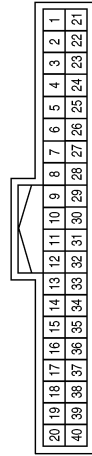

Terminal No.	Color of Wire	Signal Name
4	Y/G	AT1 RANGE DN
5	SB	AT4 RANGE UP
8	Y/R	BATTERY
9	B	GND
11	L	CAN-H
12	P	CAN-L
21	Y/R	IGN
24	O/L	RUN/START
35	LG/R	TOW MODE
36	Y/V	TOW MODE LAMP
38	V/W	MANUAL MODE

Connector No.	M31
Connector Name	WIRE TO WIRE
Connector Color	WHITE

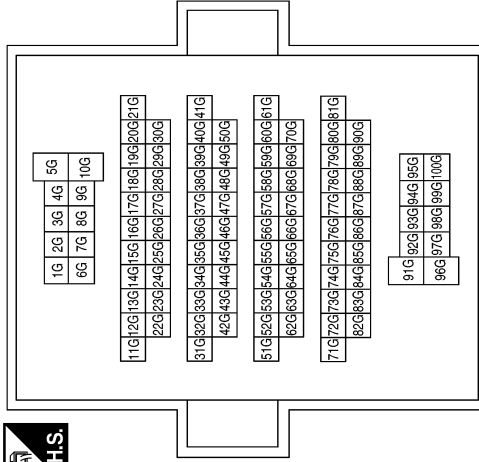

Terminal No.	Color of Wire	Signal Name
31G	L	-
32G	P	-
36G	R/Y	-
51G	G/W	-
62G	BR	-
63G	P	-
64G	R	-
94G	G/W	-
95G	G	-
97G	Y/R	-
98G	W/B	-

ABDIA0924GB

A  
B  
C  
TM  
E  
F  
G  
H  
I  
J  
K  
L  
M  
N  
O  
P

# A/T CONTROL SYSTEM

< WIRING DIAGRAM >

Connector No.	M39
Connector Name	FUSE BLOCK (J/B)
Connector Color	WHITE

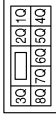

Terminal No.	Color of Wire	Signal Name
1Q	G/R	-
4Q	Y/R	-

Connector No.	M40
Connector Name	WIRE TO WIRE
Connector Color	WHITE

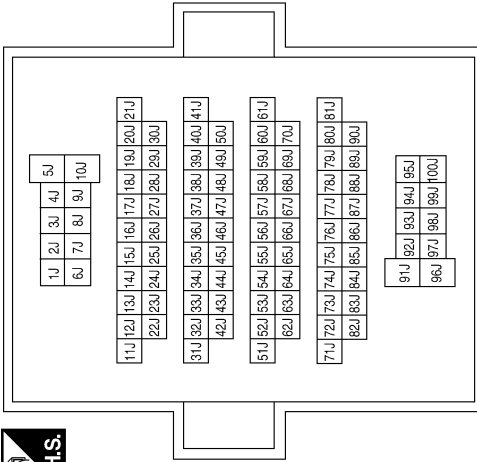

Terminal No.	Color of Wire	Signal Name
11J	L	-
12J	P	-

Connector No.	M56
Connector Name	WIRE TO WIRE
Connector Color	WHITE

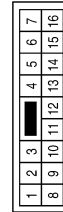

Terminal No.	Color of Wire	Signal Name
2	SB	-
3	Y/G	-
14	B	-

Connector No.	M60
Connector Name	FUSE BLOCK (J/B)
Connector Color	WHITE

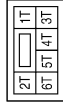

Terminal No.	Color of Wire	Signal Name
1T	R/Y	-
6T	O	-

Connector No.	M67
Connector Name	TOW MODE SWITCH
Connector Color	GRAY



Terminal No.	Color of Wire	Signal Name
1	LG/R	-
2	B	-
5	Y/V	-
6	B	-



# A/T CONTROL SYSTEM

< WIRING DIAGRAM >

Connector No.	M68
Connector Name	A/T SHIFT SELECTOR (COLUMN SHIFT)
Connector Color	WHITE



Terminal No.	Color of Wire	Signal Name
2	B	-
4	LG	-
5	Y/G	-
6	V/W	-
7	BR	-

Connector No.	M73
Connector Name	BACK-UP LAMP RELAY
Connector Color	BROWN



Terminal No.	Color of Wire	Signal Name
1	G	-
2	R	-
3	G	-
5	G/W	-
6	W/B	-
7	Y/R	-

Connector No.	M101
Connector Name	JOINT CONNECTOR-M03
Connector Color	BLUE

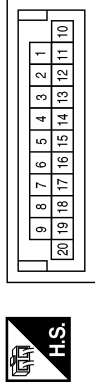

Terminal No.	Color of Wire	Signal Name
1	G/R	-
2	G/R	-
10	P	-
11	P	-

Connector No.	M151
Connector Name	CONDENSER-3
Connector Color	WHITE

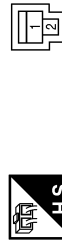

Terminal No.	Color of Wire	Signal Name
1	V/W	-
2	B	-

Connector No.	M178
Connector Name	JOINT CONNECTOR-M08
Connector Color	WHITE

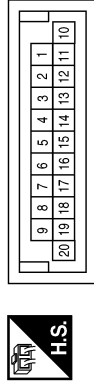

Terminal No.	Color of Wire	Signal Name
10	L	-
11	L	-
16	P	-
17	P	-

Connector No.	M179
Connector Name	JOINT CONNECTOR-M07
Connector Color	WHITE

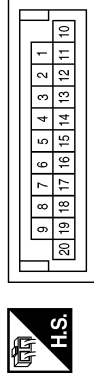

Terminal No.	Color of Wire	Signal Name
10	L	-
11	L	-
13	L	-
16	P	-
17	P	-
19	P	-

ABDIA0926GB

# A/T CONTROL SYSTEM

< WIRING DIAGRAM >

Connector No.	M201
Connector Name	WIRE TO WIRE
Connector Color	WHITE

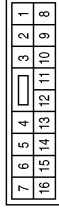

Terminal No.	Color of Wire	Signal Name
2	SB	-
3	Y/G	-
14	B	-

Connector No.	M192
Connector Name	JOINT CONNECTOR-M02
Connector Color	GREEN

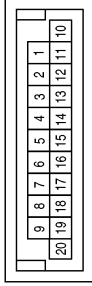

Terminal No.	Color of Wire	Signal Name
13	Y/R	-
14	Y/R	-
15	Y/R	-

Connector No.	M182
Connector Name	JOINT CONNECTOR-M09
Connector Color	GREEN

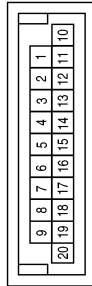

Terminal No.	Color of Wire	Signal Name
13	L	-
14	L	-
17	P	-
18	P	-

Connector No.	E5
Connector Name	WIRE TO WIRE
Connector Color	WHITE

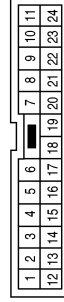

Terminal No.	Color of Wire	Signal Name
5	L	-
6	P	-
13	R	-
15	P	-
17	Y/R	-
18	G/W	-
19	B/R	-

Connector No.	E2
Connector Name	WIRE TO WIRE
Connector Color	WHITE



Terminal No.	Color of Wire	Signal Name
6	B	-
8	Y/R	-
15	BR	-

Connector No.	M203
Connector Name	A/T SHIFT SELECTOR (FLOOR SHIFT)
Connector Color	WHITE



Terminal No.	Color of Wire	Signal Name
1	SB	-
2	B	-
7	Y/G	-
8	B	-

ABDIA0927GB

# A/T CONTROL SYSTEM

< WIRING DIAGRAM >

Connector No.	E38
Connector Name	STOP LAMP SWITCH (COLUMN SHIFT)
Connector Color	WHITE



Terminal No.	Color of Wire	Signal Name
1	R/Y	-
2	R/G	-

Connector No.	E25
Connector Name	TCM (TRANSMISSION CONTROL MODULE) RELAY
Connector Color	BLUE



Terminal No.	Color of Wire	Signal Name
1	B	-
2	BR	-
3	P	-
5	Y/R	-

Connector No.	E12
Connector Name	STOP LAMP RELAY
Connector Color	BLACK



Terminal No.	Color of Wire	Signal Name
1	R/Y	-
2	L/W	-
3	R/G	-
4	R/B	-

Connector No.	E119
Connector Name	IPDM E/R (INTELLIGENT POWER DISTRIBUTION MODULE ENGINE ROOM)
Connector Color	WHITE

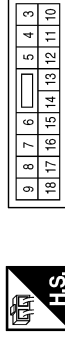

Terminal No.	Color of Wire	Signal Name
14	Y/R	A/T CU IGN SUPPLY
16	G	REVERSE LAMP

Connector No.	E50
Connector Name	WIRE TO WIRE
Connector Color	BROWN



Terminal No.	Color of Wire	Signal Name
1	P	-
2	L	-

Connector No.	E42
Connector Name	STOP LAMP SWITCH (FLOOR SHIFT)
Connector Color	BLACK



Terminal No.	Color of Wire	Signal Name
1	R/Y	-
2	R/G	-

ABDIA0928GB

A  
B  
C  
TM  
E  
F  
G  
H  
I  
J  
K  
L  
M  
N  
O  
P

# A/T CONTROL SYSTEM

< WIRING DIAGRAM >

Connector No.	E122
Connector Name	IPDM E/R (INTELLIGENT POWER DISTRIBUTION MODULE ENGINE ROOM)
Connector Color	WHITE

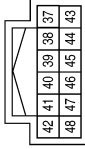

Terminal No.	Color of Wire	Signal Name
38	B	GND (SIGNAL)
48	B/R	RANGE SW

Connector No.	E121
Connector Name	IPDM E/R (INTELLIGENT POWER DISTRIBUTION MODULE ENGINE ROOM)
Connector Color	BROWN

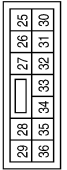

Terminal No.	Color of Wire	Signal Name
27	W/B	TTOW REV LAMP

Connector No.	E120
Connector Name	IPDM E/R (INTELLIGENT POWER DISTRIBUTION MODULE ENGINE ROOM)
Connector Color	WHITE

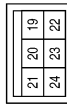

Terminal No.	Color of Wire	Signal Name
19	W/R	STARTER MTR
21	BR	IGN SW (ST)

Connector No.	E125
Connector Name	ABS ACTUATOR AND ELECTRIC UNIT (CONTROL UNIT)
Connector Color	BLACK

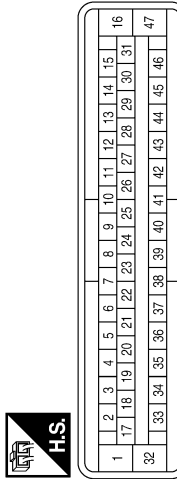

Terminal No.	Color of Wire	Signal Name
11	L	CAN-H
15	P	CAN-L
35	L/W	BRL OUT
41	R/B	BLS

Connector No.	E124
Connector Name	IPDM E/R (INTELLIGENT POWER DISTRIBUTION MODULE ENGINE ROOM)
Connector Color	BLACK



Terminal No.	Color of Wire	Signal Name
59	B	GND (POWER)

ABDIA0929GB

# A/T CONTROL SYSTEM

< WIRING DIAGRAM >

Connector No.	F9
Connector Name	A/T ASSEMBLY (FLOOR SHIFT)
Connector Color	GREEN

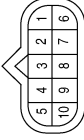

Terminal No.	Color of Wire	Signal Name
1	P	-
2	P	-
3	L	-
4	G/W	-
5	B	-
6	Y/R	-
7	R	-
8	P	-
9	B/R	-
10	B	-

Terminal No.	Color of Wire	Signal Name
31G	L	-
32G	P	-
36G	R/Y	-
51G	G/W	-
62G	BR	-
63G	P	-
64G	R	-
94G	G/W	-
95G	G	-
97G	Y/R	-
98G	W/B	-

Connector No.	E152
Connector Name	WIRE TO WIRE
Connector Color	WHITE

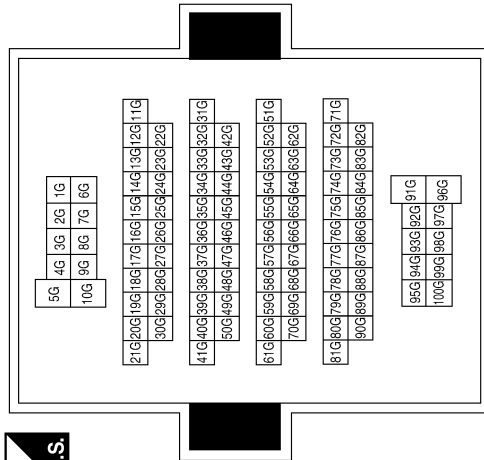

Connector No.	F17
Connector Name	A/T ASSEMBLY (COLUMN SHIFT)
Connector Color	GREEN

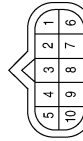

Terminal No.	Color of Wire	Signal Name
1	P	-
2	P	-
3	L	-
4	G/W	-
5	B	-
6	Y/R	-

Connector No.	F14
Connector Name	WIRE TO WIRE
Connector Color	WHITE

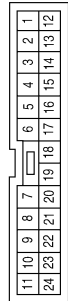

Terminal No.	Color of Wire	Signal Name
5	L	-
6	P	-
13	R	-
15	P	-
17	Y/R	-
18	G/W	-
19	B/R	-

ABDIA0930GB

A  
B  
C  
TM  
E  
F  
G  
H  
I  
J  
K  
L  
M  
N  
O  
P

# A/T CONTROL SYSTEM

< WIRING DIAGRAM >

Connector No.	F25
Connector Name	DIODE-2
Connector Color	WHITE



Terminal No.	Color of Wire	Signal Name
1	Y/R	-
2	BR	-

Connector No.	F32
Connector Name	WIRE TO WIRE
Connector Color	WHITE

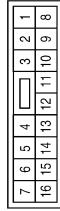

Terminal No.	Color of Wire	Signal Name
6	B	-
8	Y/R	-
15	BR	-

Connector No.	F502
Connector Name	TCM (TRANSMISSION CONTROL MODULE)
Connector Color	GRAY

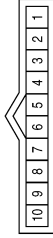

Terminal No.	Color of Wire	Signal Name
1	BR	CAN-H
2	LY	CAN-L
3	-	-
4	R	VIGN
5	-	-
6	L	K-LINE
7	O	REV LAMP RLY
8	G	START-RLY
9	W	STAND BY SUPPLY-1
10	GR	STAND BY SUPPLY-2

Connector No.	F503
Connector Name	TCM (TRANSMISSION CONTROL MODULE)
Connector Color	GREEN

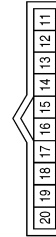

Terminal No.	Color of Wire	Signal Name
11	W	TR SW4
12	GR	TR SW2
13	BR	TR SW1
14	L	TR SW3
15	-	-

Terminal No.	Color of Wire	Signal Name
16	B	OUTPUT SPEED SEN GND
17	R	OUTPUT SPEED SEN
18	O	ATF SENS
19	G	ATF SENS
20	Y	OUTPUT SPEED SEN POWER

Connector No.	F504
Connector Name	TCM (TRANSMISSION CONTROL MODULE)
Connector Color	WHITE



Terminal No.	Color of Wire	Signal Name
21	B	POWER GND-1
22	Y	POWER GND-2

ABDIA0931GB

# A/T CONTROL SYSTEM

< WIRING DIAGRAM >

Connector No.	F505
Connector Name	TRANSMISSION RANGE SWITCH
Connector Color	GRAY

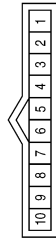

Terminal No.	Color of Wire	Signal Name
1	BR	-
2	W	-
3	GR	-
4	-	-
5	L	-
6	G	-
7	O	-
8	Y	-
9	R	-
10	B	-

Connector No.	F506
Connector Name	TRANSMISSION RANGE SWITCH
Connector Color	GRAY



Terminal No.	Color of Wire	Signal Name
11	L	-
12	W	-
13	R	-

Connector No.	B69
Connector Name	WIRE TO WIRE
Connector Color	WHITE



Terminal No.	Color of Wire	Signal Name
11J	L	-
12J	P	-

Connector No.	B75
Connector Name	WIRE TO WIRE
Connector Color	BROWN

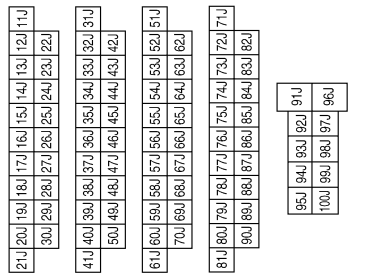

ABDIA0932GB

A  
B  
C  
TM  
E  
F  
G  
H  
I  
J  
K  
L  
M  
N  
O  
P

# A/T SHIFT LOCK SYSTEM

< WIRING DIAGRAM >

## A/T SHIFT LOCK SYSTEM

Wiring Diagram - Column Shift

INFOID:000000009885887

A/T SHIFT LOCK SYSTEM - COLUMN SHIFT

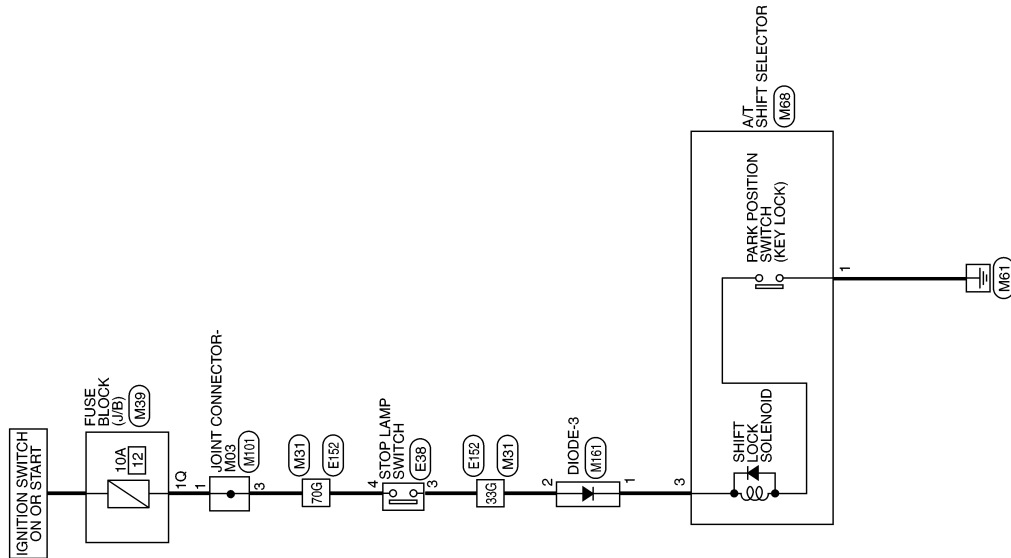

ABDWA0616GB



# A/T SHIFT LOCK SYSTEM

< WIRING DIAGRAM >

## A/T SHIFT LOCK SYSTEM CONNECTORS - COLUMN SHIFT

Connector No.	M31
Connector Name	WIRE TO WIRE
Connector Color	WHITE

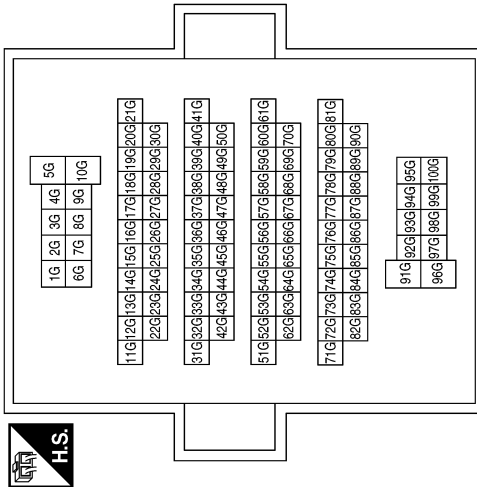

Terminal No.	Color of Wire	Signal Name
33G	GR	— (COLUMN SHIFT)
70G	G/R	—

Connector No.	M39
Connector Name	FUSE BLOCK (J/B)
Connector Color	WHITE

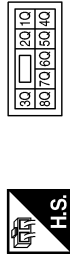

Terminal No.	Color of Wire	Signal Name
1Q	G/R	—

Connector No.	M68
Connector Name	A/T SHIFT SELECTOR (COLUMN SHIFT)
Connector Color	WHITE

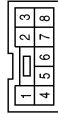

Terminal No.	Color of Wire	Signal Name
1	B	—
3	G/W	—

Connector No.	M101
Connector Name	JOINT CONNECTOR-M03
Connector Color	BLUE

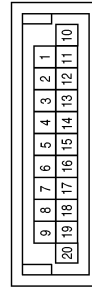

Terminal No.	Color of Wire	Signal Name
1	G/R	—
3	G/R	—

Connector No.	M161
Connector Name	DIODE-3
Connector Color	WHITE



Terminal No.	Color of Wire	Signal Name
1	G/W	—
2	GR	—

Connector No.	E38
Connector Name	STOP LAMP SWITCH (COLUMN SHIFT)
Connector Color	WHITE



Terminal No.	Color of Wire	Signal Name
3	GR	—
4	G/R	—

ABDIA0934GB

# A/T SHIFT LOCK SYSTEM

< WIRING DIAGRAM >

Connector No.	E152
Connector Name	WIRE TO WIRE
Connector Color	WHITE

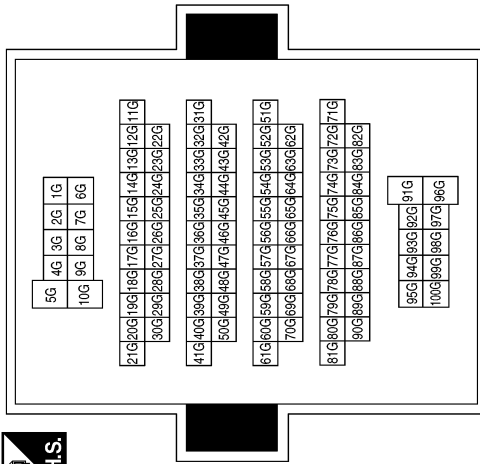

Terminal No.	Color of Wire	Signal Name
33G	GR	-- (COLUMN SHIFT)
70G	G/R	--

ABDIA0935GB



# A/T SHIFT LOCK SYSTEM

< WIRING DIAGRAM >

## A/T SHIFT LOCK SYSTEM CONNECTORS - FLOOR SHIFT

Connector No.	M4
Connector Name	FUSE BLOCK (J/B)
Connector Color	WHITE



Terminal No.	13P	Color of Wire	P	Signal Name	-
--------------	-----	---------------	---	-------------	---

Connector No.	M24
Connector Name	COMBINATION METER
Connector Color	WHITE

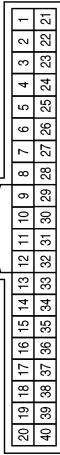

Terminal No.	29	Color of Wire	W/R	Signal Name	SPEED OUT
--------------	----	---------------	-----	-------------	-----------

Connector No.	M27
Connector Name	KEY SWITCH AND KEY LOCK SOLENOID
Connector Color	WHITE

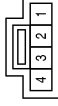

Terminal No.	1	Color of Wire	G/W	Signal Name	-
2	W/G	-	-	-	
3	P	-	-	-	
4	B/R	-	-	-	

Connector No.	M31
Connector Name	WIRE TO WIRE
Connector Color	WHITE

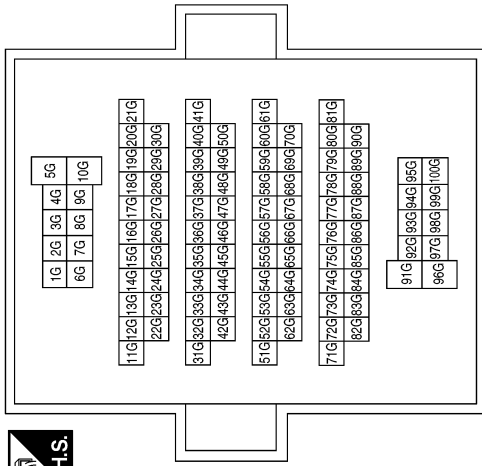

Terminal No.	33G	Color of Wire	R/G	Signal Name	- (FLOOR SHIFT)
36G	R/Y	-	-	-	

Connector No.	M39
Connector Name	FUSE BLOCK (J/B)
Connector Color	WHITE

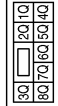

Terminal No.	1Q	Color of Wire	G/R	Signal Name	-
--------------	----	---------------	-----	-------------	---

ABDIA0936GB

# A/T SHIFT LOCK SYSTEM

< WIRING DIAGRAM >

Connector No.	M81
Connector Name	SHIFT LOCK CONTROL UNIT
Connector Color	GRAY

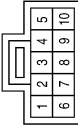

Terminal No.	Color of Wire	Signal Name
1	P	BAT (+)
2	L/R	DETENT SW (KEY)
3	GR	DETENT SW
4	R/G	STOP LAMP SWITCH
5	W/R	8P VSP
6	G/R	IGN SW
7	R/W	SHIFT LOCK SOL
8	B	GND
9	GW	KEY LOCK SOL OUTPUT (LOCK)
10	W/G	KEY LOCK SOL OUTPUT (UNLOCK)

Connector No.	M60
Connector Name	FUSE BLOCK (J/B)
Connector Color	WHITE

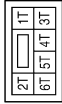

Terminal No.	Color of Wire	Signal Name
1T	R/Y	-

Connector No.	M56
Connector Name	WIRE TO WIRE
Connector Color	WHITE

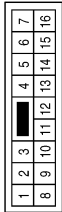

Terminal No.	Color of Wire	Signal Name
1	P	-
4	GR	-
5	R/W	-
10	L/R	-
11	B/R	-

Connector No.	M201
Connector Name	WIRE TO WIRE
Connector Color	WHITE

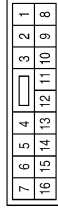

Terminal No.	Color of Wire	Signal Name
1	P	-
4	GR	-
5	R/W	-
10	L/R	-
11	B/R	-

Connector No.	M178
Connector Name	JOINT CONNECTOR-M08
Connector Color	WHITE

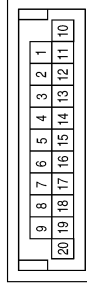

Terminal No.	Color of Wire	Signal Name
4	B/R	-
6	B/R	-

Connector No.	M101
Connector Name	JOINT CONNECTOR-M03
Connector Color	BLUE

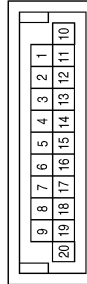

Terminal No.	Color of Wire	Signal Name
1	G/R	-
3	G/R	-
10	P	-
12	P	-
13	P	-
14	P	-

ABDIA0937GB

A  
B  
C  
TM  
E  
F  
G  
H  
I  
J  
K  
L  
M  
N  
O  
P

# A/T SHIFT LOCK SYSTEM

< WIRING DIAGRAM >

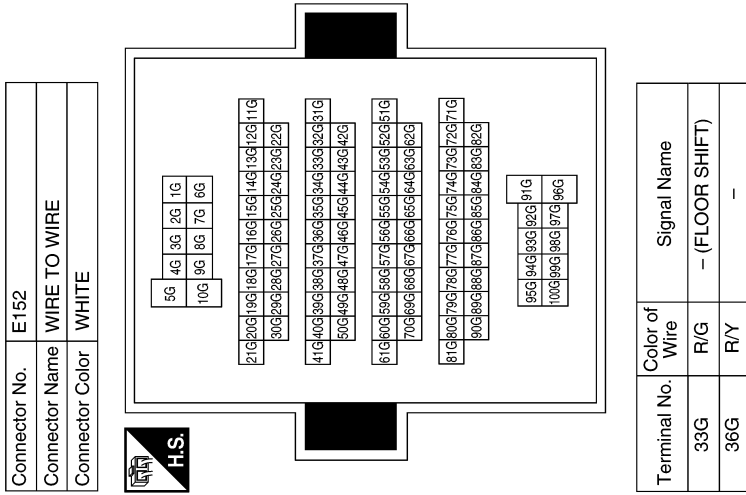

# SYSTEM SYMPTOM

< SYMPTOM DIAGNOSIS >

## SYMPTOM DIAGNOSIS

### SYSTEM SYMPTOM

#### Symptom Table

INFOID:000000009885889

- The diagnostics item numbers show the sequence for inspection. Inspect in order from item 1.
- Overhaul and inspect inside the A/T only if A/T fluid condition is NG. Refer to [TM-172](#). "Checking the A/T Fluid (ATF)".

No.	Items	Symptom	Condition	Diagnostic Item	Reference page
1		Large shock. ("N"→"D" position)	ON vehicle	1. Engine idle speed	<a href="#">EC-125</a>
				2. Engine speed signal	<a href="#">TM-61</a>
				3. Accelerator pedal position sensor	<a href="#">TM-79</a>
				4. Control cable adjustment	<a href="#">TM-190</a>
				5. ATF temperature sensor	<a href="#">TM-81</a>
				6. Front brake solenoid valve	<a href="#">TM-92</a>
				7. CAN communication line	<a href="#">TM-48</a>
				8. Fluid level and state	<a href="#">TM-172</a>
				9. Line pressure test	<a href="#">TM-181</a>
				10. Control valve with TCM	<a href="#">TM-201</a>
			OFF vehicle	11. Forward brake (Parts behind drum support is impossible to perform inspection by disassembly. Refer to <a href="#">TM-10</a> , <a href="#">TM-11</a> .)	<a href="#">TM-229</a>
2	Shift Shock	Shock is too large when changing D1→D2.	ON vehicle	1. Accelerator pedal position sensor	<a href="#">TM-79</a>
				2. Control cable adjustment	<a href="#">TM-190</a>
				3. Direct clutch solenoid valve	<a href="#">TM-94</a>
				4. CAN communication line	<a href="#">TM-48</a>
				5. Engine speed signal	<a href="#">TM-61</a>
				6. Input speed sensor	<a href="#">TM-56</a>
				7. Output speed sensor and vehicle speed signal	<a href="#">TM-58</a> , <a href="#">TM-84</a>
				8. Fluid level and state	<a href="#">TM-172</a>
				9. Control valve with TCM	<a href="#">TM-201</a>
			OFF vehicle	10. Direct clutch	<a href="#">TM-263</a>
3		Shock is too large when changing D2→D3.	ON vehicle	1. Accelerator pedal position sensor	<a href="#">TM-79</a>
				2. Control cable adjustment	<a href="#">TM-190</a>
				3. High and low reverse clutch solenoid valve	<a href="#">TM-96</a>
				4. CAN communication line	<a href="#">TM-48</a>
				5. Engine speed signal	<a href="#">TM-61</a>
				6. Input speed sensor	<a href="#">TM-56</a>
				7. Output speed sensor and vehicle speed signal	<a href="#">TM-58</a> , <a href="#">TM-84</a>
				8. Fluid level and state	<a href="#">TM-172</a>
				9. Control valve with TCM	<a href="#">TM-201</a>
			OFF vehicle	10. High and low reverse clutch	<a href="#">TM-261</a>

# SYSTEM SYMPTOM

## < SYMPTOM DIAGNOSIS >

No.	Items	Symptom	Condition	Diagnostic Item	Reference page
4		Shock is too large when changing D3→D4.	ON vehicle	1. Accelerator pedal position sensor	<a href="#">TM-79</a>
				2. Control cable adjustment	<a href="#">TM-190</a>
				3. Input clutch solenoid valve	<a href="#">TM-90</a>
				4. CAN communication line	<a href="#">TM-48</a>
				5. Engine speed signal	<a href="#">TM-61</a>
				6. Input speed sensor	<a href="#">TM-56</a>
				7. Output speed sensor and vehicle speed signal	<a href="#">TM-58,</a> <a href="#">TM-84</a>
				8. Fluid level and state	<a href="#">TM-172</a>
				9. Control valve with TCM	<a href="#">TM-201</a>
			OFF vehicle	10. Input clutch	<a href="#">TM-251</a>
5	Shift Shock	Shock is too large when changing D4→D5.	ON vehicle	1. Accelerator pedal position sensor	<a href="#">TM-79</a>
				2. Control cable adjustment	<a href="#">TM-190</a>
				3. Front brake solenoid valve	<a href="#">TM-92</a>
				4. CAN communication line	<a href="#">TM-48</a>
				5. Engine speed signal	<a href="#">TM-61</a>
				6. Input speed sensor	<a href="#">TM-56</a>
				7. Output speed sensor and vehicle speed signal	<a href="#">TM-58,</a> <a href="#">TM-84</a>
				8. Fluid level and state	<a href="#">TM-172</a>
				9. Control valve with TCM	<a href="#">TM-201</a>
			OFF vehicle	10. Front brake (brake band)	<a href="#">TM-217</a>
				11. Input clutch	<a href="#">TM-251</a>
6		Shock is too large for downshift when accelerator pedal is pressed.	ON vehicle	1. Accelerator pedal position sensor	<a href="#">TM-79</a>
				2. Control cable adjustment	<a href="#">TM-190</a>
				3. CAN communication line	<a href="#">TM-48</a>
				4. Engine speed signal	<a href="#">TM-61</a>
				5. Input speed sensor	<a href="#">TM-56</a>
				6. Output speed sensor and vehicle speed signal	<a href="#">TM-58,</a> <a href="#">TM-84</a>
				7. Fluid level and state	<a href="#">TM-172</a>
				8. Control valve with TCM	<a href="#">TM-201</a>
			OFF vehicle	9. Front brake (brake band)	<a href="#">TM-217</a>
				10. Input clutch	<a href="#">TM-251</a>
				11. High and low reverse clutch	<a href="#">TM-261</a>
				12. Direct clutch	<a href="#">TM-263</a>



# SYSTEM SYMPTOM

## < SYMPTOM DIAGNOSIS >

No.	Items	Symptom	Condition	Diagnostic Item	Reference page
7		Shock is too large for upshift when accelerator pedal is released.	ON vehicle	1. Accelerator pedal position sensor	<a href="#">TM-79</a>
				2. Control cable adjustment	<a href="#">TM-190</a>
				3. Engine speed signal	<a href="#">TM-61</a>
				4. CAN communication line	<a href="#">TM-48</a>
				5. Input speed sensor	<a href="#">TM-56</a>
				6. Output speed sensor and vehicle speed signal	<a href="#">TM-58,</a> <a href="#">TM-84</a>
				7. Fluid level and state	<a href="#">TM-172</a>
				8. Control valve with TCM	<a href="#">TM-201</a>
			OFF vehicle	9. Front brake (brake band)	<a href="#">TM-217</a>
				10. Input clutch	<a href="#">TM-251</a>
				11. High and low reverse clutch	<a href="#">TM-261</a>
				12. Direct clutch	<a href="#">TM-263</a>
8	Shift Shock	Shock is too large for lock-up.	ON vehicle	1. Accelerator pedal position sensor	<a href="#">TM-79</a>
				2. Control cable adjustment	<a href="#">TM-190</a>
				3. Engine speed signal	<a href="#">TM-61</a>
				4. CAN communication line	<a href="#">TM-48</a>
				5. Input speed sensor	<a href="#">TM-56</a>
				6. Output speed sensor and vehicle speed signal	<a href="#">TM-58,</a> <a href="#">TM-84</a>
				7. Torque converter clutch solenoid valve	<a href="#">TM-73</a>
				8. Fluid level and state	<a href="#">TM-172</a>
				9. Control valve with TCM	<a href="#">TM-201</a>
			OFF vehicle	10. Torque converter	<a href="#">TM-229</a>
9		Shock is too large during engine brake.	ON vehicle	1. Accelerator pedal position sensor	<a href="#">TM-79</a>
				2. Control cable adjustment	<a href="#">TM-190</a>
				3. CAN communication line	<a href="#">TM-48</a>
				4. Fluid level and state	<a href="#">TM-172</a>
				5. Control valve with TCM	<a href="#">TM-201</a>
			OFF vehicle	6. Front brake (brake band)	<a href="#">TM-217</a>
				7. Input clutch	<a href="#">TM-251</a>
				8. High and low reverse clutch	<a href="#">TM-261</a>
				9. Direct clutch	<a href="#">TM-263</a>

A  
B  
C  
TM  
E  
F  
G  
H  
I  
J  
K  
L  
M  
N  
O  
P

## SYSTEM SYMPTOM

### < SYMPTOM DIAGNOSIS >

No.	Items	Symptom	Condition	Diagnostic Item	Reference page
10		Gear does not change from D → D2.	ON vehicle	1. Fluid level and state	<a href="#">TM-172</a>
				2. Output speed sensor and vehicle speed signal	<a href="#">TM-58</a> , <a href="#">TM-84</a>
				3. Direct clutch solenoid valve	<a href="#">TM-94</a>
				4. Line pressure test	<a href="#">TM-181</a>
				5. CAN communication line	<a href="#">TM-48</a>
				6. Control valve with TCM	<a href="#">TM-201</a>
			OFF vehicle	7. Direct clutch	<a href="#">TM-263</a>
11		Gear does not change from D → D3.	ON vehicle	1. Fluid level and state	<a href="#">TM-172</a>
				2. Output speed sensor and vehicle speed signal	<a href="#">TM-58</a> , <a href="#">TM-84</a>
				3. High and low reverse clutch solenoid valve	<a href="#">TM-96</a>
				4. Line pressure test	<a href="#">TM-181</a>
				5. CAN communication line	<a href="#">TM-48</a>
				6. Control valve with TCM	<a href="#">TM-201</a>
			OFF vehicle	7. High and low reverse clutch	<a href="#">TM-261</a>
12	No Up Shift	Gear does not change from D → D4.	ON vehicle	1. Fluid level and state	<a href="#">TM-172</a>
				2. Output speed sensor and vehicle speed signal	<a href="#">TM-58</a> , <a href="#">TM-84</a>
				3. Input clutch solenoid valve	<a href="#">TM-90</a>
				4. Front brake solenoid valve	<a href="#">TM-92</a>
				5. Line pressure test	<a href="#">TM-181</a>
				6. CAN communication line	<a href="#">TM-48</a>
				7. Control valve with TCM	<a href="#">TM-201</a>
OFF vehicle	8. Input clutch	<a href="#">TM-251</a>			
13		Gear does not change from D → D5.	ON vehicle	1. Fluid level and state	<a href="#">TM-172</a>
				2. Output speed sensor and vehicle speed signal	<a href="#">TM-58</a> , <a href="#">TM-84</a>
				3. Front brake solenoid valve	<a href="#">TM-92</a>
				4. Direct clutch solenoid valve	<a href="#">TM-94</a>
				5. Input speed sensor	<a href="#">TM-56</a>
				6. Line pressure test	<a href="#">TM-181</a>
				7. CAN communication line	<a href="#">TM-48</a>
				8. Control valve with TCM	<a href="#">TM-201</a>
			OFF vehicle	9. Front brake (brake band)	<a href="#">TM-217</a>
				10. Input clutch	<a href="#">TM-251</a>

# SYSTEM SYMPTOM

## < SYMPTOM DIAGNOSIS >

No.	Items	Symptom	Condition	Diagnostic Item	Reference page
14	No Down Shift	In "D" or "4" range, does not downshift to 4GR.	ON vehicle	1. Fluid level and state	<a href="#">TM-172</a>
				2. Output speed sensor and vehicle speed signal	<a href="#">TM-58</a> , <a href="#">TM-84</a>
				3. Front brake solenoid valve	<a href="#">TM-92</a>
				4. Direct clutch solenoid valve	<a href="#">TM-94</a>
				5. CAN communication line	<a href="#">TM-48</a>
				6. Line pressure test	<a href="#">TM-181</a>
				7. Control valve with TCM	<a href="#">TM-201</a>
			OFF vehicle	8. Front brake (brake band)	<a href="#">TM-217</a>
			9. Input clutch	<a href="#">TM-251</a>	
15	No Down Shift	In "D" or "3" range, does not downshift to 3GR.	ON vehicle	1. Fluid level and state	<a href="#">TM-172</a>
				2. Output speed sensor and vehicle speed signal	<a href="#">TM-58</a> , <a href="#">TM-84</a>
				3. Input clutch solenoid valve	<a href="#">TM-90</a>
				4. Front brake solenoid valve	<a href="#">TM-92</a>
				5. CAN communication line	<a href="#">TM-48</a>
				6. Line pressure test	<a href="#">TM-181</a>
				7. Control valve with TCM	<a href="#">TM-201</a>
			OFF vehicle	8. Input clutch	<a href="#">TM-251</a>
16	No Down Shift	In "D" or "2" range, does not downshift to 2GR.	ON vehicle	1. Fluid level and state	<a href="#">TM-172</a>
				2. Output speed sensor and vehicle speed signal	<a href="#">TM-58</a> , <a href="#">TM-84</a>
				3. High and low reverse clutch solenoid valve	<a href="#">TM-96</a>
				4. CAN communication line	<a href="#">TM-48</a>
				5. Line pressure test	<a href="#">TM-181</a>
				6. Control valve with TCM	<a href="#">TM-201</a>
			OFF vehicle	7. High and low reverse clutch	<a href="#">TM-261</a>
17	No Down Shift	In "D" or "1" range, does not downshift to 1GR.	ON vehicle	1. Fluid level and state	<a href="#">TM-172</a>
				2. Output speed sensor and vehicle speed signal	<a href="#">TM-58</a> , <a href="#">TM-84</a>
				3. Direct clutch solenoid valve	<a href="#">TM-94</a>
				4. CAN communication line	<a href="#">TM-48</a>
				5. Line pressure test	<a href="#">TM-181</a>
				6. Control valve with TCM	<a href="#">TM-201</a>
			OFF vehicle	7. Direct clutch	<a href="#">TM-263</a>

A  
B  
C  
TM  
E  
F  
G  
H  
I  
J  
K  
L  
M  
N  
O  
P

## SYSTEM SYMPTOM

### < SYMPTOM DIAGNOSIS >

No.	Items	Symptom	Condition	Diagnostic Item	Reference page
18	Slips/Will Not engage	When "D" position, remains in 1GR.	ON vehicle	1. Fluid level and state	<a href="#">TM-172</a>
				2. Output speed sensor and vehicle speed signal	<a href="#">TM-58, TM-84</a>
				3. Direct clutch solenoid valve	<a href="#">TM-94</a>
				4. Line pressure test	<a href="#">TM-181</a>
				5. CAN communication line	<a href="#">TM-48</a>
				6. Control valve with TCM	<a href="#">TM-201</a>
			OFF vehicle	7. 3rd one-way clutch	<a href="#">TM-249</a>
				8. 1st one-way clutch	<a href="#">TM-256</a>
				9. Gear system	<a href="#">TM-217</a>
				10. Reverse brake	<a href="#">TM-229</a>
				11. Forward one-way clutch (Parts behind drum support is impossible to perform inspection by disassembly. Refer to <a href="#">TM-10, TM-11</a> )	<a href="#">TM-229</a>
				12. Forward brake (Parts behind drum support is impossible to perform inspection by disassembly. Refer to <a href="#">TM-10, TM-11</a> )	<a href="#">TM-229</a>
19		When "D" position, remains in 2GR.	ON vehicle	1. Fluid level and state	<a href="#">TM-172</a>
				2. Output speed sensor and vehicle speed signal	<a href="#">TM-58, TM-84</a>
				3. Low coast brake solenoid valve	<a href="#">TM-98</a>
				4. Line pressure test	<a href="#">TM-181</a>
				5. CAN communication line	<a href="#">TM-48</a>
				6. Control valve with TCM	<a href="#">TM-201</a>
			OFF vehicle	7. 3rd one-way clutch	<a href="#">TM-249</a>
				8. Gear system	<a href="#">TM-217</a>
				9. Direct clutch	<a href="#">TM-263</a>
				10. Forward brake (Parts behind drum support is impossible to perform inspection by disassembly. Refer to <a href="#">TM-10, TM-11</a> )	<a href="#">TM-229</a>

# SYSTEM SYMPTOM

## < SYMPTOM DIAGNOSIS >

No.	Items	Symptom	Condition	Diagnostic Item	Reference page
20		When "D" position, remains in 3GR.	ON vehicle	1. Fluid level and state	<a href="#">TM-172</a>
				2. Output speed sensor and vehicle speed signal	<a href="#">TM-58, TM-84</a>
				3. Line pressure test	<a href="#">TM-181</a>
				4. CAN communication line	<a href="#">TM-48</a>
				5. Control valve with TCM	<a href="#">TM-201</a>
			OFF vehicle	6. 3rd one-way clutch	<a href="#">TM-249</a>
				7. Gear system	<a href="#">TM-217</a>
				8. High and low reverse clutch	<a href="#">TM-261</a>
				9. Forward one-way clutch (Parts behind drum support is impossible to perform inspection by disassembly. Refer to <a href="#">TM-10, TM-11</a> )	<a href="#">TM-229</a>
				10. Forward brake (Parts behind drum support is impossible to perform inspection by disassembly. Refer to <a href="#">TM-10, TM-11</a> )	<a href="#">TM-229</a>
21	Slips/Will Not engage	When "D" position, remains in 4GR.	ON vehicle	1. Fluid level and state	<a href="#">TM-172</a>
				2. Output speed sensor and vehicle speed signal	<a href="#">TM-58, TM-84</a>
				3. Input clutch solenoid valve	<a href="#">TM-90</a>
				4. Direct clutch solenoid valve	<a href="#">TM-94</a>
				5. High and low reverse clutch solenoid valve	<a href="#">TM-96</a>
				6. Low coast brake solenoid valve	<a href="#">TM-98</a>
				7. Front brake solenoid valve	<a href="#">TM-92</a>
				8. Line pressure test	<a href="#">TM-181</a>
				9. CAN communication line	<a href="#">TM-48</a>
				10. Control valve with TCM	<a href="#">TM-201</a>
			OFF vehicle	11. Input clutch	<a href="#">TM-251</a>
				12. Gear system	<a href="#">TM-217</a>
				13. High and low reverse clutch	<a href="#">TM-261</a>
				14. Direct clutch	<a href="#">TM-263</a>

A  
B  
C  
TM  
E  
F  
G  
H  
I  
J  
K  
L  
M  
N  
O  
P

## SYSTEM SYMPTOM

### < SYMPTOM DIAGNOSIS >

No.	Items	Symptom	Condition	Diagnostic Item	Reference page
22		When "D" position, remains in 5GR.	ON vehicle	1. Fluid level and state	<a href="#">TM-172</a>
				2. Output speed sensor and vehicle speed signal	<a href="#">TM-58, TM-84</a>
				3. Front brake solenoid valve	<a href="#">TM-92</a>
				4. Line pressure test	<a href="#">TM-181</a>
				5. CAN communication line	<a href="#">TM-48</a>
				6. Control valve with TCM	<a href="#">TM-201</a>
			OFF vehicle	7. Front brake (brake band)	<a href="#">TM-217</a>
				8. Input clutch	<a href="#">TM-251</a>
				9. Gear system	<a href="#">TM-217</a>
				10. High and low reverse clutch	<a href="#">TM-261</a>
23	Slips/Will Not Engage	Vehicle cannot be started from D1.	ON vehicle	1. Fluid level and state	<a href="#">TM-172</a>
				2. Accelerator pedal position sensor	<a href="#">TM-79</a>
				3. Line pressure test	<a href="#">TM-181</a>
				4. CAN communication line	<a href="#">TM-48</a>
				5. Control valve with TCM	<a href="#">TM-201</a>
			OFF vehicle	6. Torque converter	<a href="#">TM-229</a>
				7. Oil pump assembly	<a href="#">TM-247</a>
				8. 3rd one-way clutch	<a href="#">TM-249</a>
				9. 1st one-way clutch	<a href="#">TM-256</a>
				10. Gear system	<a href="#">TM-217</a>
				11. Reverse brake	<a href="#">TM-229</a>
				12. Forward one-way clutch (Parts behind drum support is impossible to perform inspection by disassembly. Refer to <a href="#">TM-10, TM-11</a> )	<a href="#">TM-229</a>
				13. Forward brake (Parts behind drum support is impossible to perform inspection by disassembly. Refer to <a href="#">TM-10, TM-11</a> )	<a href="#">TM-229</a>
24		Does not lock-up.	ON vehicle	1. Fluid level and state	<a href="#">TM-172</a>
				2. Line pressure test	<a href="#">TM-181</a>
				3. Engine speed signal	<a href="#">TM-61</a>
				4. Input speed sensor	<a href="#">TM-56</a>
				5. Torque converter clutch solenoid valve	<a href="#">TM-73</a>
				6. CAN communication line	<a href="#">TM-48</a>
				7. Control valve with TCM	<a href="#">TM-201</a>
			OFF vehicle	8. Torque converter	<a href="#">TM-229</a>
				9. Oil pump assembly	<a href="#">TM-247</a>

# SYSTEM SYMPTOM

## < SYMPTOM DIAGNOSIS >

No.	Items	Symptom	Condition	Diagnostic Item	Reference page	
25	Slips/Will Not engage	Does not hold lock-up condition.	ON vehicle	1. Fluid level and state	<a href="#">TM-172</a>	
				2. Line pressure test	<a href="#">TM-181</a>	
				3. Engine speed signal	<a href="#">TM-61</a>	
				4. Input speed sensor	<a href="#">TM-56</a>	
				5. Torque converter clutch solenoid valve	<a href="#">TM-73</a>	
				6. CAN communication line	<a href="#">TM-48</a>	
				7. Control valve with TCM	<a href="#">TM-201</a>	
			OFF vehicle	8. Torque converter	<a href="#">TM-229</a>	
				9. Oil pump assembly	<a href="#">TM-247</a>	
26		Slips/Will Not engage	Lock-up is not released.	ON vehicle	1. Fluid level and state	<a href="#">TM-172</a>
					2. Line pressure test	<a href="#">TM-181</a>
					3. Engine speed signal	<a href="#">TM-61</a>
					4. Input speed sensor	<a href="#">TM-56</a>
					5. Torque converter clutch solenoid valve	<a href="#">TM-73</a>
					6. CAN communication line	<a href="#">TM-48</a>
					7. Control valve with TCM	<a href="#">TM-201</a>
				OFF vehicle	8. Torque converter	<a href="#">TM-229</a>
					9. Oil pump assembly	<a href="#">TM-247</a>
27	Slips/Will Not engage		No shock at all or the clutch slips when vehicle changes speed D1 → D2.	ON vehicle	1. Fluid level and state	<a href="#">TM-172</a>
					2. Output speed sensor and vehicle speed signal	<a href="#">TM-58</a> , <a href="#">TM-84</a>
					3. Direct clutch solenoid valve	<a href="#">TM-94</a>
					4. CAN communication line	<a href="#">TM-48</a>
					5. Line pressure test	<a href="#">TM-181</a>
					6. Control valve with TCM	<a href="#">TM-201</a>
				OFF vehicle	7. Torque converter	<a href="#">TM-229</a>
					8. Oil pump assembly	<a href="#">TM-247</a>
					9. 3rd one-way clutch	<a href="#">TM-249</a>
		10. Gear system			<a href="#">TM-217</a>	
		11. Direct clutch			<a href="#">TM-263</a>	
		12. Forward brake (Parts behind drum support is impossible to perform inspection by disassembly. Refer to <a href="#">TM-10</a> , <a href="#">TM-11</a> )			<a href="#">TM-229</a>	

A  
B  
C  
TM  
E  
F  
G  
H  
I  
J  
K  
L  
M  
N  
O  
P

## SYSTEM SYMPTOM

### < SYMPTOM DIAGNOSIS >

No.	Items	Symptom	Condition	Diagnostic Item	Reference page
28	Slips/Will Not engage	No shock at all or the clutch slips when vehicle changes speed D2 → D3.	ON vehicle	1. Fluid level and state	<a href="#">TM-172</a>
				2. Output speed sensor and vehicle speed signal	<a href="#">TM-58</a> , <a href="#">TM-84</a>
				3. High and low reverse clutch solenoid valve	<a href="#">TM-96</a>
				4. CAN communication line	<a href="#">TM-48</a>
				5. Line pressure test	<a href="#">TM-181</a>
				6. Control valve with TCM	<a href="#">TM-201</a>
			OFF vehicle	7. Torque converter	<a href="#">TM-229</a>
				8. Oil pump assembly	<a href="#">TM-247</a>
				9. 3rd one-way clutch	<a href="#">TM-249</a>
				10. Gear system	<a href="#">TM-217</a>
				11. High and low reverse clutch	<a href="#">TM-261</a>
				12. Forward one-way clutch (Parts behind drum support is impossible to perform inspection by disassembly. Refer to <a href="#">TM-10</a> , <a href="#">TM-11</a> )	<a href="#">TM-229</a>
				13. Forward brake (Parts behind drum support is impossible to perform inspection by disassembly. Refer to <a href="#">TM-10</a> , <a href="#">TM-11</a> )	<a href="#">TM-229</a>
29		No shock at all or the clutch slips when vehicle changes speed D3 → D4.	ON vehicle	1. Fluid level and state	<a href="#">TM-172</a>
				2. Output speed sensor and vehicle speed signal	<a href="#">TM-58</a> , <a href="#">TM-84</a>
				3. Input clutch solenoid valve	<a href="#">TM-90</a>
				4. Front brake solenoid valve	<a href="#">TM-92</a>
				5. CAN communication line	<a href="#">TM-48</a>
				6. Line pressure test	<a href="#">TM-181</a>
				7. Control valve with TCM	<a href="#">TM-201</a>
			OFF vehicle	8. Torque converter	<a href="#">TM-229</a>
				9. Oil pump assembly	<a href="#">TM-247</a>
				10. Input clutch	<a href="#">TM-251</a>
				11. Gear system	<a href="#">TM-217</a>
				12. High and low reverse clutch	<a href="#">TM-261</a>
				13. Direct clutch	<a href="#">TM-263</a>



# SYSTEM SYMPTOM

## < SYMPTOM DIAGNOSIS >

No.	Items	Symptom	Condition	Diagnostic Item	Reference page
30	Slips/Will Not engage	No shock at all or the clutch slips when vehicle changes speed D4 → D5.	ON vehicle	1. Fluid level and state	<a href="#">TM-172</a>
				2. Output speed sensor and vehicle speed signal	<a href="#">TM-58</a> , <a href="#">TM-84</a>
				3. Front brake solenoid valve	<a href="#">TM-92</a>
				4. Direct clutch solenoid valve	<a href="#">TM-94</a>
				5. CAN communication line	<a href="#">TM-48</a>
				6. Line pressure test	<a href="#">TM-181</a>
				7. Control valve with TCM	<a href="#">TM-201</a>
			OFF vehicle	8. Torque converter	<a href="#">TM-229</a>
				9. Oil pump assembly	<a href="#">TM-247</a>
				10. Front brake (brake band)	<a href="#">TM-217</a>
				11. Input clutch	<a href="#">TM-251</a>
				12. Gear system	<a href="#">TM-217</a>
				13. High and low reverse clutch	<a href="#">TM-261</a>
31	Slips/Will Not engage	When you press the accelerator pedal and shift speed D5→ D4 the engine idles or the transmission slips.	ON vehicle	1. Fluid level and state	<a href="#">TM-172</a>
				2. Output speed sensor and vehicle speed signal	<a href="#">TM-58</a> , <a href="#">TM-84</a>
				3. Front brake solenoid valve	<a href="#">TM-92</a>
				4. Direct clutch solenoid valve	<a href="#">TM-94</a>
				5. CAN communication line	<a href="#">TM-48</a>
				6. Line pressure test	<a href="#">TM-181</a>
				7. Control valve with TCM	<a href="#">TM-201</a>
			OFF vehicle	8. Torque converter	<a href="#">TM-229</a>
				9. Oil pump assembly	<a href="#">TM-247</a>
				10. Input clutch	<a href="#">TM-251</a>
				11. Gear system	<a href="#">TM-217</a>
				12. High and low reverse clutch	<a href="#">TM-261</a>
				13. Direct clutch	<a href="#">TM-263</a>

A  
B  
C  
TM  
E  
F  
G  
H  
I  
J  
K  
L  
M  
N  
O  
P

## SYSTEM SYMPTOM

### < SYMPTOM DIAGNOSIS >

No.	Items	Symptom	Condition	Diagnostic Item	Reference page
32	Slips/Will Not engage	When you press the accelerator pedal and shift speed D <sub>4</sub> → D <sub>3</sub> the engine idles or the transmission slips.	ON vehicle	1. Fluid level and state	<a href="#">TM-172</a>
				2. Output speed sensor and vehicle speed signal	<a href="#">TM-58, TM-84</a>
				3. Input clutch solenoid valve	<a href="#">TM-90</a>
				4. Front brake solenoid valve	<a href="#">TM-92</a>
				5. CAN communication line	<a href="#">TM-48</a>
				6. Line pressure test	<a href="#">TM-181</a>
				7. Control valve with TCM	<a href="#">TM-201</a>
			OFF vehicle	8. Torque converter	<a href="#">TM-229</a>
				9. Oil pump assembly	<a href="#">TM-247</a>
				10. 3rd one-way clutch	<a href="#">TM-249</a>
				11. Gear system	<a href="#">TM-217</a>
				12. High and low reverse clutch	<a href="#">TM-261</a>
				13. Forward one- way clutch (Parts behind drum support is impossible to perform inspection by disassembly. Refer to <a href="#">TM-10, TM-11</a> )	<a href="#">TM-229</a>
				14. Forward brake (Parts behind drum support is impossible to perform inspection by disassembly. Refer to <a href="#">TM-10, TM-11</a> )	<a href="#">TM-229</a>
33		When you press the accelerator pedal and shift speed D <sub>3</sub> → D <sub>2</sub> the engine idles or the transmission slips.	ON vehicle	1. Fluid level and state	<a href="#">TM-172</a>
				2. Output speed sensor and vehicle speed signal	<a href="#">TM-58, TM-84</a>
				3. High and low reverse clutch solenoid valve	<a href="#">TM-96</a>
				4. Direct clutch solenoid valve	<a href="#">TM-94</a>
				5. CAN communication line	<a href="#">TM-48</a>
				6. Line pressure test	<a href="#">TM-181</a>
				7. Control valve with TCM	<a href="#">TM-201</a>
			OFF vehicle	8. Torque converter	<a href="#">TM-229</a>
				9. Oil pump assembly	<a href="#">TM-247</a>
				10. 3rd one-way clutch	<a href="#">TM-249</a>
				11. Gear system	<a href="#">TM-217</a>
				12. Direct clutch	<a href="#">TM-263</a>
				13. Forward brake (Parts behind drum support is impossible to perform inspection by disassembly. Refer to <a href="#">TM-10, TM-11</a> )	<a href="#">TM-229</a>

# SYSTEM SYMPTOM

## < SYMPTOM DIAGNOSIS >

No.	Items	Symptom	Condition	Diagnostic Item	Reference page
34	Slips/Will Not Engage	When you press the accelerator pedal and shift speed D <sub>2</sub> → D <sub>1</sub> the engine idles or the transmission slips.	ON vehicle	1. Fluid level and state	<a href="#">TM-172</a>
				2. Output speed sensor and vehicle speed signal	<a href="#">TM-58, TM-84</a>
				3. Direct clutch solenoid valve	<a href="#">TM-94</a>
				4. CAN communication line	<a href="#">TM-48</a>
				5. Line pressure test	<a href="#">TM-181</a>
				6. Control valve with TCM	<a href="#">TM-201</a>
			OFF vehicle	7. Torque converter	<a href="#">TM-229</a>
				8. Oil pump assembly	<a href="#">TM-247</a>
				9. 3rd one-way clutch	<a href="#">TM-249</a>
				10. 1st one-way clutch	<a href="#">TM-256</a>
				11. Gear system	<a href="#">TM-217</a>
				12. Reverse brake	<a href="#">TM-229</a>
				13. Forward one- way clutch (Parts behind drum support is impossible to perform inspection by disassembly. Refer to <a href="#">TM-10, TM-11</a> )	<a href="#">TM-229</a>
				14. Forward brake (Parts behind drum support is impossible to perform inspection by disassembly. Refer to <a href="#">TM-10, TM-11</a> )	<a href="#">TM-229</a>
35	With selector lever in "D" position, acceleration is extremely poor.		ON vehicle	1. Fluid level and state	<a href="#">TM-172</a>
				2. Line pressure test	<a href="#">TM-181</a>
				3. Accelerator pedal position sensor	<a href="#">TM-79</a>
				4. CAN communication line	<a href="#">TM-48</a>
				5. Transmission range switch	<a href="#">TM-53</a>
				6. Control cable adjustment	<a href="#">TM-190</a>
				7. Control valve with TCM	<a href="#">TM-201</a>
			OFF vehicle	8. Torque converter	<a href="#">TM-229</a>
				9. Oil pump assembly	<a href="#">TM-247</a>
				10. 1st one-way clutch	<a href="#">TM-256</a>
				11. Gear system	<a href="#">TM-217</a>
				12. Reverse brake	<a href="#">TM-229</a>
				13. Forward one- way clutch (Parts behind drum support is impossible to perform inspection by disassembly. Refer to <a href="#">TM-10, TM-11</a> )	<a href="#">TM-229</a>
				14. Forward brake (Parts behind drum support is impossible to perform inspection by disassembly. Refer to <a href="#">TM-10, TM-11</a> )	<a href="#">TM-229</a>

A  
B  
C  
TM  
E  
F  
G  
H  
I  
J  
K  
L  
M  
N  
O  
P

## SYSTEM SYMPTOM

### < SYMPTOM DIAGNOSIS >

No.	Items	Symptom	Condition	Diagnostic Item	Reference page
36		With selector lever in "R" position, acceleration is extremely poor.	ON vehicle	1. Fluid level and state	<a href="#">TM-172</a>
				2. Line pressure test	<a href="#">TM-181</a>
				3. Accelerator pedal position sensor	<a href="#">TM-79</a>
				4. High and low reverse clutch solenoid valve	<a href="#">TM-96</a>
				5. CAN communication line	<a href="#">TM-48</a>
				6. Transmission range switch	<a href="#">TM-53</a>
				7. Control cable adjustment	<a href="#">TM-190</a>
				8. Control valve with TCM	<a href="#">TM-201</a>
			OFF vehicle	9. Gear system	<a href="#">TM-217</a>
				10. Output shaft	<a href="#">TM-229</a>
				11. Reverse brake	<a href="#">TM-229</a>
37	Slips/Will Not Engage	While starting off by accelerating in 1st, engine races or slippage occurs.	ON vehicle	1. Fluid level and state	<a href="#">TM-172</a>
				2. Line pressure test	<a href="#">TM-181</a>
				3. Accelerator pedal position sensor	<a href="#">TM-79</a>
				4. CAN communication line	<a href="#">TM-48</a>
				5. Control valve with TCM	<a href="#">TM-201</a>
			OFF vehicle	6. Torque converter	<a href="#">TM-229</a>
				7. Oil pump assembly	<a href="#">TM-247</a>
				8. 3rd one-way clutch	<a href="#">TM-249</a>
				9. 1st one-way clutch	<a href="#">TM-256</a>
				10. Gear system	<a href="#">TM-217</a>
				11. Reverse brake	<a href="#">TM-229</a>
				12. Forward one-way clutch (Parts behind drum support is impossible to perform inspection by disassembly. Refer to <a href="#">TM-10</a> , <a href="#">TM-11</a> )	<a href="#">TM-229</a>
				13. Forward brake (Parts behind drum support is impossible to perform inspection by disassembly. Refer to <a href="#">TM-10</a> , <a href="#">TM-11</a> )	<a href="#">TM-229</a>
38		While accelerating in 2nd, engine races or slippage occurs.	ON vehicle	1. Fluid level and state	<a href="#">TM-172</a>
				2. Line pressure test	<a href="#">TM-181</a>
				3. Accelerator pedal position sensor	<a href="#">TM-79</a>
				4. CAN communication line	<a href="#">TM-48</a>
				5. Direct clutch solenoid valve	<a href="#">TM-94</a>
				6. Control valve with TCM	<a href="#">TM-201</a>
			OFF vehicle	7. Torque converter	<a href="#">TM-229</a>
				8. Oil pump assembly	<a href="#">TM-247</a>
				9. 3rd one-way clutch	<a href="#">TM-249</a>
				10. Gear system	<a href="#">TM-217</a>
				11. Direct clutch	<a href="#">TM-263</a>
				12. Forward brake (Parts behind drum support is impossible to perform inspection by disassembly. Refer to <a href="#">TM-10</a> , <a href="#">TM-11</a> )	<a href="#">TM-229</a>

# SYSTEM SYMPTOM

## < SYMPTOM DIAGNOSIS >

No.	Items	Symptom	Condition	Diagnostic Item	Reference page
39	Slips/Will Not Engage	While accelerating in 3rd, engine races or slippage occurs.	ON vehicle	1. Fluid level and state	<a href="#">TM-172</a>
				2. Line pressure test	<a href="#">TM-181</a>
				3. Accelerator pedal position sensor	<a href="#">TM-79</a>
				4. CAN communication line	<a href="#">TM-48</a>
				5. High and low reverse clutch solenoid valve	<a href="#">TM-96</a>
				6. Control valve with TCM	<a href="#">TM-201</a>
			OFF vehicle	7. Torque converter	<a href="#">TM-229</a>
				8. Oil pump assembly	<a href="#">TM-247</a>
				9. 3rd one-way clutch	<a href="#">TM-249</a>
				10. Gear system	<a href="#">TM-217</a>
				11. High and low reverse clutch	<a href="#">TM-261</a>
				12. Forward one- way clutch (Parts behind drum support is impossible to perform inspection by disassembly. Refer to <a href="#">TM-10</a> , <a href="#">TM-11</a> )	<a href="#">TM-229</a>
				13. Forward brake (Parts behind drum support is impossible to perform inspection by disassembly. Refer to <a href="#">TM-10</a> , <a href="#">TM-11</a> )	<a href="#">TM-229</a>
40		While accelerating in 4th, engine races or slippage occurs.	ON vehicle	1. Fluid level and state	<a href="#">TM-172</a>
				2. Line pressure test	<a href="#">TM-181</a>
				3. Accelerator pedal position sensor	<a href="#">TM-79</a>
				4. CAN communication line	<a href="#">TM-48</a>
				5. Input clutch solenoid valve	<a href="#">TM-90</a>
				6. Control valve with TCM	<a href="#">TM-201</a>
			OFF vehicle	7. Torque converter	<a href="#">TM-229</a>
				8. Oil pump assembly	<a href="#">TM-247</a>
				9. Input clutch	<a href="#">TM-251</a>
				10. Gear system	<a href="#">TM-217</a>
				11. High and low reverse clutch	<a href="#">TM-261</a>
				12. Direct clutch	<a href="#">TM-263</a>

A  
B  
C  
TM  
E  
F  
G  
H  
I  
J  
K  
L  
M  
N  
O  
P

## SYSTEM SYMPTOM

### < SYMPTOM DIAGNOSIS >

No.	Items	Symptom	Condition	Diagnostic Item	Reference page
41		While accelerating in 5th, engine races or slippage occurs.	ON vehicle	1. Fluid level and state	<a href="#">TM-172</a>
				2. Line pressure test	<a href="#">TM-181</a>
				3. Accelerator pedal position sensor	<a href="#">TM-79</a>
				4. CAN communication line	<a href="#">TM-48</a>
				5. Front brake solenoid valve	<a href="#">TM-92</a>
				6. Control valve with TCM	<a href="#">TM-201</a>
			OFF vehicle	7. Torque converter	<a href="#">TM-229</a>
				8. Oil pump assembly	<a href="#">TM-247</a>
				9. Front brake (brake band)	<a href="#">TM-217</a>
				10. Input clutch	<a href="#">TM-251</a>
				11. Gear system	<a href="#">TM-217</a>
				12. High and low reverse clutch	<a href="#">TM-261</a>
42	Slips/Will Not Engage	Slips at lock-up.	ON vehicle	1. Fluid level and state	<a href="#">TM-172</a>
				2. Line pressure test	<a href="#">TM-181</a>
				3. Engine speed signal	<a href="#">TM-61</a>
				4. Input speed sensor	<a href="#">TM-56</a>
				5. Torque converter clutch solenoid valve	<a href="#">TM-73</a>
				6. CAN communication line	<a href="#">TM-48</a>
				7. Control valve with TCM	<a href="#">TM-201</a>
			OFF vehicle	8. Torque converter	<a href="#">TM-229</a>
				9. Oil pump assembly	<a href="#">TM-247</a>
43		No creep at all.	ON vehicle	1. Fluid level and state	<a href="#">TM-172</a>
				2. Line pressure test	<a href="#">TM-181</a>
				3. Accelerator pedal position sensor	<a href="#">TM-79</a>
				4. Direct clutch solenoid valve	<a href="#">TM-94</a>
				5. Transmission range switch	<a href="#">TM-53</a>
				6. CAN communication line	<a href="#">TM-48</a>
				7. Control cable adjustment	<a href="#">TM-190</a>
				8. Control valve with TCM	<a href="#">TM-201</a>
			OFF vehicle	9. Torque converter	<a href="#">TM-229</a>
				10. Oil pump assembly	<a href="#">TM-247</a>
				11. 1st one-way clutch	<a href="#">TM-256</a>
				12. Gear system	<a href="#">TM-217</a>
				13. Reverse brake	<a href="#">TM-229</a>
				14. Direct clutch	<a href="#">TM-263</a>
				15. Forward one- way clutch (Parts behind drum support is impossible to perform inspection by disassembly. Refer to <a href="#">TM-10</a> , <a href="#">TM-11</a> )	<a href="#">TM-229</a>
				16. Forward brake (Parts behind drum support is impossible to perform inspection by disassembly. Refer to <a href="#">TM-10</a> , <a href="#">TM-11</a> )	<a href="#">TM-229</a>

# SYSTEM SYMPTOM

## < SYMPTOM DIAGNOSIS >

No.	Items	Symptom	Condition	Diagnostic Item	Reference page
44		Vehicle cannot run in all positions.	ON vehicle	1. Fluid level and state	<a href="#">TM-172</a>
				2. Line pressure test	<a href="#">TM-181</a>
				3. Transmission range switch	<a href="#">TM-201</a>
				4. Control cable adjustment	<a href="#">TM-190</a>
				5. Control valve with TCM	<a href="#">TM-201</a>
			OFF vehicle	6. Oil pump assembly	<a href="#">TM-247</a>
				7. Gear system	<a href="#">TM-217</a>
				8. Output shaft	<a href="#">TM-229</a>
45	Slips/Will Not Engage	With selector lever in "D" position, driving is not possible.	ON vehicle	1. Fluid level and state	<a href="#">TM-172</a>
				2. Line pressure test	<a href="#">TM-181</a>
				3. Transmission range switch	<a href="#">TM-53</a>
				4. Control cable adjustment	<a href="#">TM-190</a>
				5. Control valve with TCM	<a href="#">TM-201</a>
			OFF vehicle	6. Torque converter	<a href="#">TM-229</a>
				7. Oil pump assembly	<a href="#">TM-247</a>
				8. 1st one-way clutch	<a href="#">TM-256</a>
				9. Gear system	<a href="#">TM-217</a>
				10. Reverse brake	<a href="#">TM-229</a>
				11. Forward one-way clutch (Parts behind drum support is impossible to perform inspection by disassembly. Refer to <a href="#">TM-10</a> , <a href="#">TM-11</a> )	<a href="#">TM-229</a>
				12. Forward brake (Parts behind drum support is impossible to perform inspection by disassembly. Refer to <a href="#">TM-10</a> , <a href="#">TM-11</a> )	<a href="#">TM-229</a>
46		With selector lever in "R" position, driving is not possible.	ON vehicle	1. Fluid level and state	<a href="#">TM-172</a>
				2. Line pressure test	<a href="#">TM-181</a>
				3. Transmission range switch	<a href="#">TM-53</a>
				4. Control cable adjustment	<a href="#">TM-190</a>
				5. Control valve with TCM	<a href="#">TM-201</a>
			OFF vehicle	6. Gear system	<a href="#">TM-217</a>
				7. Output shaft	<a href="#">TM-229</a>
				8. Reverse brake	<a href="#">TM-229</a>
47	Does not change	Does not change M5 → M4.	ON vehicle	1. Transmission range switch	<a href="#">TM-53</a>
				2. Fluid level and state	<a href="#">TM-172</a>
				3. Control cable adjustment	<a href="#">TM-190</a>
				4. Manual mode switch	<a href="#">TM-102</a>
				5. CAN communication line	<a href="#">TM-48</a>
				6. Control valve with TCM	<a href="#">TM-201</a>
			OFF vehicle	7. Front brake (brake band)	<a href="#">TM-217</a>

A  
B  
C  
TM  
E  
F  
G  
H  
I  
J  
K  
L  
M  
N  
O  
P

# SYSTEM SYMPTOM

## < SYMPTOM DIAGNOSIS >

No.	Items	Symptom	Condition	Diagnostic Item	Reference page
48		Does not change M4 → M3.	ON vehicle	1. Transmission range switch	<a href="#">TM-53</a>
				2. Fluid level and state	<a href="#">TM-172</a>
				3. Control cable adjustment	<a href="#">TM-190</a>
				4. Manual mode switch	<a href="#">TM-102</a>
				5. CAN communication line	<a href="#">TM-48</a>
				6. Control valve with TCM	<a href="#">TM-201</a>
			OFF vehicle	7. Front brake (brake band)	<a href="#">TM-217</a>
				8. Input clutch	<a href="#">TM-251</a>
49	Does not change	Does not change M3 → M2.	ON vehicle	1. Transmission range switch	<a href="#">TM-53</a>
				2. Fluid level and state	<a href="#">TM-172</a>
				3. Control cable adjustment	<a href="#">TM-190</a>
				4. Manual mode switch	<a href="#">TM-102</a>
				5. CAN communication line	<a href="#">TM-48</a>
				6. Control valve with TCM	<a href="#">TM-201</a>
			OFF vehicle	7. Front brake (brake band)	<a href="#">TM-217</a>
				8. Input clutch	<a href="#">TM-251</a>
				9. High and low reverse clutch	<a href="#">TM-261</a>
50		Does not change M2 → M1.	ON vehicle	1. Transmission range switch	<a href="#">TM-53</a>
				2. Fluid level and state	<a href="#">TM-172</a>
				3. Control cable adjustment	<a href="#">TM-190</a>
				4. Manual mode switch	<a href="#">TM-102</a>
				5. CAN communication line	<a href="#">TM-48</a>
				6. Control valve with TCM	<a href="#">TM-201</a>
			OFF vehicle	7. Input clutch	<a href="#">TM-251</a>
				8. High and low reverse clutch	<a href="#">TM-261</a>
				9. Direct clutch	<a href="#">TM-263</a>
51		Cannot be changed to manual mode.	ON vehicle	1. Manual mode switch	<a href="#">TM-102</a>
				2. Input speed sensor	<a href="#">TM-56</a>
				3. CAN communication line	<a href="#">TM-48</a>
52	Others	Shift point is high in "D" position.	ON vehicle	1. Output speed sensor and vehicle speed signal	<a href="#">TM-58</a> , <a href="#">TM-84</a>
				2. Accelerator pedal position sensor	<a href="#">TM-79</a>
				3. CAN communication line	<a href="#">TM-48</a>
				4. ATF temperature sensor	<a href="#">TM-81</a>
				5. Control valve with TCM	<a href="#">TM-201</a>



# SYSTEM SYMPTOM

## < SYMPTOM DIAGNOSIS >

No.	Items	Symptom	Condition	Diagnostic Item	Reference page
53		Shift point is low in "D" position.	ON vehicle	1. Output speed sensor and vehicle speed signal	<a href="#">TM-58</a> , <a href="#">TM-84</a>
				2. Accelerator pedal position sensor	<a href="#">TM-79</a>
				3. CAN communication line	<a href="#">TM-48</a>
				4. Control valve with TCM	<a href="#">TM-201</a>
54		Judder occurs during lock-up.	ON vehicle	1. Fluid level and state	<a href="#">TM-172</a>
				2. Engine speed signal	<a href="#">TM-61</a>
				3. Input speed sensor	<a href="#">TM-56</a>
				4. Output speed sensor and vehicle speed signal	<a href="#">TM-58</a> , <a href="#">TM-84</a>
			OFF vehicle	5. Accelerator pedal position sensor	<a href="#">TM-79</a>
				6. CAN communication line	<a href="#">TM-48</a>
				7. Torque converter clutch solenoid valve	<a href="#">TM-73</a>
				8. Control valve with TCM	<a href="#">TM-201</a>
55	Others	Strange noise in "R" position.	ON vehicle	1. Fluid level and state	<a href="#">TM-172</a>
				2. Engine speed signal	<a href="#">TM-61</a>
				3. CAN communication line	<a href="#">TM-48</a>
				4. Control valve with TCM	<a href="#">TM-201</a>
			OFF vehicle	5. Torque converter	<a href="#">TM-229</a>
				6. Oil pump assembly	<a href="#">TM-247</a>
				7. Gear system	<a href="#">TM-217</a>
				8. High and low reverse clutch	<a href="#">TM-261</a>
				9. Reverse brake	<a href="#">TM-229</a>
56		Strange noise in "N" position.	ON vehicle	1. Fluid level and state	<a href="#">TM-172</a>
				2. Engine speed signal	<a href="#">TM-61</a>
				3. CAN communication line	<a href="#">TM-48</a>
				4. Control valve with TCM	<a href="#">TM-201</a>
			OFF vehicle	5. Torque converter	<a href="#">TM-229</a>
				6. Oil pump assembly	<a href="#">TM-247</a>
				7. Gear system	<a href="#">TM-217</a>
57		Strange noise in "D" position.	ON vehicle	1. Fluid level and state	<a href="#">TM-172</a>
				2. Engine speed signal	<a href="#">TM-61</a>
				3. CAN communication line	<a href="#">TM-48</a>
				4. Control valve with TCM	<a href="#">TM-201</a>
			OFF vehicle	5. Torque converter	<a href="#">TM-229</a>
				6. Oil pump assembly	<a href="#">TM-247</a>
				7. Gear system	<a href="#">TM-217</a>
				8. Forward brake (Parts behind drum support is impossible to perform inspection by disassembly. Refer to <a href="#">TM-10</a> , <a href="#">TM-11</a> )	<a href="#">TM-229</a>

A  
B  
C  
TM  
E  
F  
G  
H  
I  
J  
K  
L  
M  
N  
O  
P

# SYSTEM SYMPTOM

## < SYMPTOM DIAGNOSIS >

No.	Items	Symptom	Condition	Diagnostic Item	Reference page
58		Vehicle dose not decelerate by engine brake.	ON vehicle	1. Transmission range switch	<a href="#">TM-53</a>
				2. Fluid level and state	<a href="#">TM-172</a>
				3. Control cable adjustment	<a href="#">TM-190</a>
				4. 1st position switch (floor shift models), manual mode switch (column shift models)	<a href="#">TM-116</a> (floor shift models), <a href="#">TM-102</a> (column shift models)
				5. CAN communication line	<a href="#">TM-48</a>
				6. Control valve with TCM	<a href="#">TM-201</a>
			OFF vehicle	7. Input clutch	<a href="#">TM-251</a>
				8. High and low reverse clutch	<a href="#">TM-261</a>
				9. Direct clutch	<a href="#">TM-263</a>
59	Others	Engine brake does not operate in "2" position.	ON vehicle	1. Transmission range switch	<a href="#">TM-53</a>
				2. Fluid level and state	<a href="#">TM-172</a>
				3. Control cable adjustment	<a href="#">TM-190</a>
				5. CAN communication line	<a href="#">TM-48</a>
				6. Control valve with TCM	<a href="#">TM-201</a>
				OFF vehicle	7. Front brake (brake band)
			8. Input clutch		<a href="#">TM-251</a>
			9. High and low reverse clutch		<a href="#">TM-261</a>
			60		Engine brake does not operate in "1" position.
2. Fluid level and state	<a href="#">TM-172</a>				
3. Control cable adjustment	<a href="#">TM-190</a>				
4. 1st position switch	<a href="#">TM-116</a>				
5. CAN communication line	<a href="#">TM-48</a>				
6. Control valve with TCM	<a href="#">TM-201</a>				
OFF vehicle	7. Input clutch	<a href="#">TM-251</a>			
	8. High and low reverse clutch	<a href="#">TM-261</a>			
	9. Direct clutch	<a href="#">TM-263</a>			
61		Engine brake does not work M5 → M4.	ON vehicle	1. Transmission range switch	<a href="#">TM-53</a>
				2. Fluid level and state	<a href="#">TM-172</a>
				3. Control cable adjustment	<a href="#">TM-190</a>
				4. Manual mode switch	<a href="#">TM-102</a>
				5. CAN communication line	<a href="#">TM-48</a>
				6. Control valve with TCM	<a href="#">TM-201</a>
			OFF vehicle	7. Front brake (brake band)	<a href="#">TM-217</a>
				8. Input clutch	<a href="#">TM-251</a>

# SYSTEM SYMPTOM

## < SYMPTOM DIAGNOSIS >

No.	Items	Symptom	Condition	Diagnostic Item	Reference page
62		Engine brake does not work M4 → M3.	ON vehicle	1. Transmission range switch	<a href="#">TM-53</a>
				2. Fluid level and state	<a href="#">TM-172</a>
				3. Control cable adjustment	<a href="#">TM-190</a>
				4. Manual mode switch	<a href="#">TM-102</a>
				5. CAN communication line	<a href="#">TM-48</a>
				6. Control valve with TCM	<a href="#">TM-201</a>
			OFF vehicle	7. Front brake (brake band)	<a href="#">TM-217</a>
				8. Input clutch	<a href="#">TM-251</a>
63	Others	Engine brake does not work M3 → M2.	ON vehicle	1. Transmission range switch	<a href="#">TM-53</a>
				2. Fluid level and state	<a href="#">TM-172</a>
				3. Control cable adjustment	<a href="#">TM-190</a>
				4. Manual mode switch	<a href="#">TM-102</a>
				5. CAN communication line	<a href="#">TM-48</a>
				6. Control valve with TCM	<a href="#">TM-201</a>
			OFF vehicle	7. Front brake (brake band)	<a href="#">TM-217</a>
				8. Input clutch	<a href="#">TM-251</a>
				9. High and low reverse clutch	<a href="#">TM-261</a>
64		Engine brake does not work M2 → M1.	ON vehicle	1. Transmission range switch	<a href="#">TM-53</a>
				2. Fluid level and state	<a href="#">TM-172</a>
				3. Control cable adjustment	<a href="#">TM-190</a>
				4. Manual mode switch	<a href="#">TM-102</a>
				5. CAN communication line	<a href="#">TM-48</a>
				6. Control valve with TCM	<a href="#">TM-201</a>
			OFF vehicle	7. Input clutch	<a href="#">TM-251</a>
				8. High and low reverse clutch	<a href="#">TM-261</a>
				9. Direct clutch	<a href="#">TM-263</a>

A  
B  
C  
TM  
E  
F  
G  
H  
I  
J  
K  
L  
M  
N  
O  
P

## SYSTEM SYMPTOM

### < SYMPTOM DIAGNOSIS >

No.	Items	Symptom	Condition	Diagnostic Item	Reference page
65	Others	Maximum speed low.	ON vehicle	1. Fluid level and state	<a href="#">TM-172</a>
				2. Line pressure test	<a href="#">TM-181</a>
				3. Accelerator pedal position sensor	<a href="#">TM-79</a>
				4. CAN communication line	<a href="#">TM-48</a>
				5. Direct clutch solenoid valve	<a href="#">TM-94</a>
				6. Control valve with TCM	<a href="#">TM-201</a>
			OFF vehicle	7. Torque converter	<a href="#">TM-229</a>
				8. Oil pump assembly	<a href="#">TM-247</a>
				9. Input clutch	<a href="#">TM-251</a>
				10. Gear system	<a href="#">TM-217</a>
				11. High and low reverse clutch	<a href="#">TM-261</a>
				12. Direct clutch	<a href="#">TM-263</a>
				13. Forward one- way clutch (Parts behind drum support is impossible to perform inspection by disassembly. Refer to <a href="#">TM-10</a> , <a href="#">TM-11</a> )	<a href="#">TM-229</a>
				14 Forward brake (Parts behind drum support is impossible to perform inspection by disassembly. Refer to <a href="#">TM-10</a> , <a href="#">TM-11</a> )	<a href="#">TM-229</a>
66	Extremely large creep.	ON vehicle	1. Engine idle speed	<a href="#">TM-61</a>	
			2. CAN communication line	<a href="#">TM-48</a>	
		OFF vehicle	3. Torque converter	<a href="#">TM-229</a>	
		67	With selector lever in "P" position, vehicle does not enter parking condition or, with selector lever in another position, parking condition is not cancelled.	ON vehicle	1. Transmission range switch
2. Control cable adjustment	<a href="#">TM-190</a>				
OFF vehicle	3. Parking pawl components			<a href="#">TM-229</a>	
68	Vehicle runs with transmission in "P" position.	ON vehicle	1. Transmission range switch	<a href="#">TM-53</a>	
			2. Fluid level and state	<a href="#">TM-172</a>	
			3. Control cable adjustment	<a href="#">TM-190</a>	
			4. Control valve with TCM	<a href="#">TM-201</a>	
			5. Parking pawl components	<a href="#">TM-229</a>	
		OFF vehicle	6. Gear system	<a href="#">TM-217</a>	

## SYSTEM SYMPTOM

### < SYMPTOM DIAGNOSIS >

No.	Items	Symptom	Condition	Diagnostic Item	Reference page
69	Others	Vehicle runs with transmission in "N" position.	ON vehicle	1. Transmission range switch	<a href="#">TM-53</a>
				2. Fluid level and state	<a href="#">TM-172</a>
				3. Control cable adjustment	<a href="#">TM-190</a>
				4. Control valve with TCM	<a href="#">TM-201</a>
			OFF vehicle	5. Input clutch	<a href="#">TM-251</a>
				6. Gear system	<a href="#">TM-217</a>
				7. Direct clutch	<a href="#">TM-263</a>
				8. Reverse brake	<a href="#">TM-229</a>
				9. Forward one- way clutch (Parts behind drum support is impossible to perform inspection by disassembly. Refer to <a href="#">TM-10</a> , <a href="#">TM-11</a> )	<a href="#">TM-229</a>
				10. Forward brake (Parts behind drum support is impossible to perform inspection by disassembly. Refer to <a href="#">TM-10</a> , <a href="#">TM-11</a> )	<a href="#">TM-229</a>
70	Others	Engine does not start in "N" or "P" position.	ON vehicle	1. Ignition switch and starter	
				2. Control cable adjustment	<a href="#">TM-190</a>
				3. Transmission range switch	<a href="#">TM-53</a>
71	Others	Engine starts in positions other than "N" or "P".	ON vehicle	1. Ignition switch and starter	
				2. Control cable adjustment	<a href="#">TM-190</a>
				3. Transmission range switch	<a href="#">TM-53</a>
72	Others	Engine stall.	ON vehicle	1. Fluid level and state	<a href="#">TM-172</a>
				2. Engine speed signal	<a href="#">TM-61</a>
				3. Input speed sensor	<a href="#">TM-56</a>
				4. Torque converter clutch solenoid valve	<a href="#">TM-73</a>
				5. CAN communication line	<a href="#">TM-48</a>
				6. Control valve with TCM	<a href="#">TM-201</a>
			OFF vehicle	7. Torque converter	<a href="#">TM-229</a>
73	Others	Engine stalls when select lever shifted "N"→"D", "R".	ON vehicle	1. Fluid level and state	<a href="#">TM-172</a>
				2. Engine speed signal	<a href="#">TM-61</a>
				3. Input speed sensor	<a href="#">TM-56</a>
				4. Torque converter clutch solenoid valve	<a href="#">TM-73</a>
				5. CAN communication line	<a href="#">TM-48</a>
				6. Control valve with TCM	<a href="#">TM-201</a>
			OFF vehicle	7. Torque converter	<a href="#">TM-229</a>

A  
B  
C  
TM  
E  
F  
G  
H  
I  
J  
K  
L  
M  
N  
O  
P

## SYSTEM SYMPTOM

### < SYMPTOM DIAGNOSIS >

No.	Items	Symptom	Condition	Diagnostic Item	Reference page
74	Others	Engine speed does not return to idle.	ON vehicle	1. Fluid level and state	<a href="#">TM-172</a>
				2. Direct clutch solenoid valve	<a href="#">TM-94</a>
				3. Front brake solenoid valve	<a href="#">TM-92</a>
				4. Accelerator pedal position sensor	<a href="#">TM-79</a>
				5. Output speed sensor and vehicle speed signal	<a href="#">TM-58,</a> <a href="#">TM-84</a>
				6. CAN communication line	<a href="#">TM-48</a>
				7. Control valve with TCM	<a href="#">TM-201</a>
			OFF vehicle	8. Front brake (brake band)	<a href="#">TM-217</a>
				9. Direct clutch	<a href="#">TM-263</a>
75		A/T CHECK indicator lamp does not come on.	ON vehicle	1. CAN communication line	<a href="#">TM-48</a>
				2. Combination meter	<a href="#">MWI-27</a>
				3. TCM power supply	<a href="#">TM-105</a>

# PRECAUTIONS

< PRECAUTION >

## PRECAUTION

### PRECAUTIONS

#### Precaution for Supplemental Restraint System (SRS) "AIR BAG" and "SEAT BELT PRE-TENSIONER"

INFOID:000000010152504

The Supplemental Restraint System such as "AIR BAG" and "SEAT BELT PRE-TENSIONER", used along with a front seat belt, helps to reduce the risk or severity of injury to the driver and front passenger for certain types of collision. This system includes seat belt switch inputs and dual stage front air bag modules. The SRS system uses the seat belt switches to determine the front air bag deployment, and may only deploy one front air bag, depending on the severity of a collision and whether the front occupants are belted or unbelted. Information necessary to service the system safely is included in the SR and SB section of this Service Manual.

#### **WARNING:**

- To avoid rendering the SRS inoperative, which could increase the risk of personal injury or death in the event of a collision which would result in air bag inflation, all maintenance must be performed by an authorized NISSAN/INFINITI dealer.
- Improper maintenance, including incorrect removal and installation of the SRS, can lead to personal injury caused by unintentional activation of the system. For removal of Spiral Cable and Air Bag Module, see the SR section.
- Do not use electrical test equipment on any circuit related to the SRS unless instructed to in this Service Manual. SRS wiring harnesses can be identified by yellow and/or orange harnesses or harness connectors.

#### PRECAUTIONS WHEN USING POWER TOOLS (AIR OR ELECTRIC) AND HAMMERS

#### **WARNING:**

- When working near the Airbag Diagnosis Sensor Unit or other Airbag System sensors with the Ignition ON or engine running, DO NOT use air or electric power tools or strike near the sensor(s) with a hammer. Heavy vibration could activate the sensor(s) and deploy the air bag(s), possibly causing serious injury.
- When using air or electric power tools or hammers, always switch the Ignition OFF, disconnect the battery and wait at least three minutes before performing any service.

#### Precaution for Work

INFOID:000000009885891

- When removing or disassembling each component, be careful not to damage or deform it. If a component may be subject to interference, be sure to protect it with a shop cloth.
- When removing (disengaging) components with a screwdriver or similar tool, be sure to wrap the component with a shop cloth or vinyl tape to protect it.
- Protect the removed parts with a shop cloth and prevent them from being dropped.
- Replace a deformed or damaged clip.
- If a part is specified as a non-reusable part, always replace it with a new one.
- Be sure to tighten bolts and nuts securely to the specified torque.
- After installation is complete, be sure to check that each part works properly.
- Follow the steps below to clean components:
  - Water soluble dirt:
    - Dip a soft cloth into lukewarm water, wring the water out of the cloth and wipe the dirty area.
    - Then rub with a soft, dry cloth.
  - Oily dirt:
    - Dip a soft cloth into lukewarm water with mild detergent (concentration: within 2 to 3%) and wipe the dirty area.
    - Then dip a cloth into fresh water, wring the water out of the cloth and wipe the detergent off.
    - Then rub with a soft, dry cloth.
  - Do not use organic solvent such as thinner, benzene, alcohol or gasoline.
  - For genuine leather seats, use a genuine leather seat cleaner.

#### Precautions for On Board Diagnosis (OBD) System of A/T and Engine

INFOID:000000009885892

The ECM has an on board diagnostic system. It will light up the malfunction indicator lamp (MIL) to warn the driver of a malfunction causing emission deterioration.

# PRECAUTIONS

## < PRECAUTION >

### CAUTION:

- Be sure to turn the ignition switch OFF and disconnect the battery cable from the negative terminal before any repair or inspection work. The open/short circuit of related switches, sensors, solenoid valves, etc. will cause the MIL to light up.
- Be sure to connect and lock the connectors securely after work. A loose (unlocked) connector will cause the MIL to light up due to an open circuit. (Be sure the connector is free from water, grease, dirt, bent terminals, etc.)
- Be sure to route and secure the harnesses properly after work. Interference of the harness with a bracket, etc. may cause the MIL to light up due to a short circuit.
- Be sure to connect rubber tubes properly after work. A misconnected or disconnected rubber tube may cause the MIL to light up due to a malfunction of the EGR system or fuel injection system, etc.
- Be sure to erase the unnecessary malfunction information (repairs completed) from the TCM and ECM before returning the vehicle to the customer.

## Precautions

INFOID:000000009885893

- Before connecting or disconnecting the A/T assembly harness connector, turn ignition switch "OFF" and disconnect negative battery cable. Because battery voltage is applied to TCM even if ignition switch is turned "OFF".

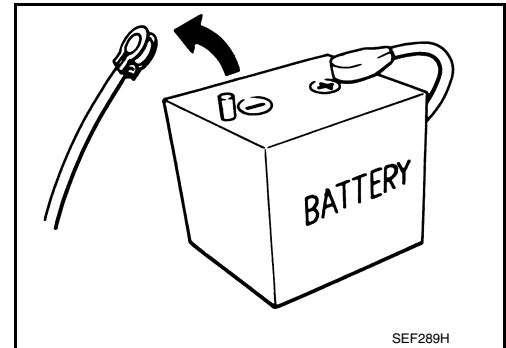

- After performing each TROUBLE DIAGNOSIS, perform "DTC (Diagnostic Trouble Code) CONFIRMATION PROCEDURE". If the repair is completed the DTC should not be displayed in the "DTC CONFIRMATION PROCEDURE".

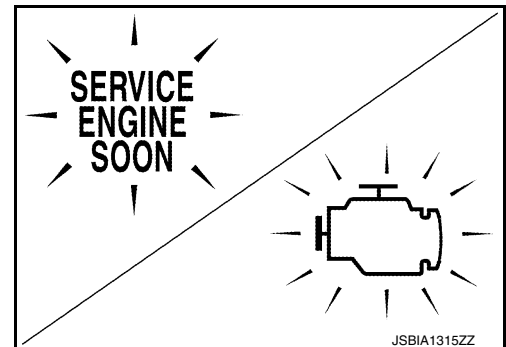

- Always use the specified brand of ATF. Refer to [MA-15. "FOR NORTH AMERICA : Fluids and Lubricants"](#) (United States and Canada) [MA-16. "FOR MEXICO : Fluids and Lubricants"](#) (Mexico).
- Use paper rags not cloth rags during work.
- After replacing the ATF, dispose of the waste oil using the methods prescribed by law, ordinance, etc.
- Before proceeding with disassembly, thoroughly clean the outside of the transmission. It is important to prevent the internal parts from becoming contaminated by dirt or other foreign matter.
- Disassembly should be done in a clean work area.
- Use lint-free cloth or towels for wiping parts clean. Common shop rags can leave fibers that could interfere with the operation of the transmission.
- Place disassembled parts in order for easier and proper assembly.
- All parts should be carefully cleaned with a general purpose, non-flammable solvent before inspection or reassembly.
- Gaskets, seals and O-rings should be replaced any time the transmission is disassembled.
- It is very important to perform functional tests whenever they are indicated.
- The valve body contains precision parts and requires extreme care when parts are removed and serviced. Place disassembled valve body parts in order for easier and proper assembly. Care will also prevent springs and small parts from becoming scattered or lost.
- Properly installed valves, sleeves, plugs, etc. will slide along bores in valve body under their own weight.
- Before assembly, apply a coat of recommended ATF to all parts. Apply petroleum jelly to protect O-rings and seals, or hold bearings and washers in place during assembly. Do not use grease.



# PRECAUTIONS

## < PRECAUTION >

- Extreme care should be taken to avoid damage to O-rings, seals and gaskets when assembling.
  - Clean or replace ATF cooler if excessive foreign material is found in oil pan or clogging strainer. Refer to [TM-176, "A/T Fluid Cooler Cleaning"](#).
  - After overhaul, refill the transmission with new ATF.
  - When the A/T drain plug is removed, only some of the fluid is drained. Old A/T fluid will remain in torque converter and ATF cooling system.
- Always follow the procedures under "Changing A/T Fluid" in the TM section when changing A/T fluid. Refer to [TM-174, "Changing the A/T Fluid \(ATF\)"](#).

## Service Notice or Precautions

INFOID:000000009885894

### ATF COOLER SERVICE

If A/T fluid contains frictional material (clutches, bands, etc.), or if an A/T is repaired, overhauled, or replaced, inspect and clean the A/T fluid cooler mounted in the radiator or replace the radiator. Flush cooler lines using cleaning solvent and compressed air after repair. For A/T fluid cooler cleaning procedure, refer to [TM-176, "A/T Fluid Cooler Cleaning"](#). For radiator replacement, refer to [CO-15, "Removal and Installation"](#).

### CHECKING AND CHANGING A/T FLUID SERVICE

Increase ATF temperature by 80°C (176°F) once, and then check ATF level in 65°C (149°F) when adjusting ATF level.

#### NOTE:

JA60 uses both systems of a water-cooling and of an air-cooling. Air-cooling system has a by-pass valve. When ATF temperature is not over 50°C (122°F) with water-cooling system OFF, it does not flow to air-cooling system. If ATF level is set without the flow of ATF, the level will be 10mm lower than the standard. Therefore, piping should be filled with ATF when adjusting level.

### OBD-II SELF-DIAGNOSIS

- A/T self-diagnosis is performed by the TCM in combination with the ECM. Refer to the table on [TM-38, "CONSULT Function \(TRANSMISSION\)"](#) for the indicator used to display each self-diagnostic result.
  - The self-diagnostic results indicated by the MIL are automatically stored in both the ECM and TCM memories.
- Always perform the procedure on [TM-36, "OBD-II Diagnostic Trouble Code \(DTC\)"](#) to complete the repair and avoid unnecessary blinking of the MIL.**
- For details of OBD-II, refer to [TM-36, "OBD-II Function for A/T System"](#).
- **Certain systems and components, especially those related to OBD, may use the new style slide-locking type harness connector. For description and how to disconnect, refer to [GI-50, "Description"](#).**

# PREPARATION

< PREPARATION >

## PREPARATION

### PREPARATION

#### Special Service Tool

INFOID:000000009885895

The actual shape of the tools may differ from those illustrated here.

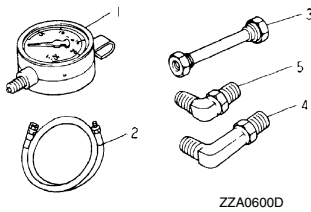
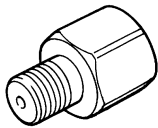
Tool number (TechMate No.) Tool name	Description
ST2505S001 (J-34301-C) Oil pressure gauge set 1. ST25051001 ( — ) Oil pressure gauge 2. ST25052000 ( — ) Hose 3. ST25053000 ( — ) Joint pipe 4. ST25054000 ( — ) Adapter 5. ST25055000 ( — ) Adapter	Measuring line pressure 
KV31103600 (J-45674) Joint pipe adapter (With ST25054000)	Measuring line pressure 
ST33400001 (J-26082) Drift	<ul style="list-style-type: none"> <li>• Installing rear oil seal (2WD models)</li> <li>• Installing oil pump housing oil seal</li> </ul> a: 60 mm (2.36 in) dia. b: 47 mm (1.85 in) dia.
KV31102400 (J-34285 and J-34285-87) Clutch spring compressor	Installing reverse brake return spring retainer a: 320 mm (12.60 in) b: 174 mm (6.85 in)
ST25850000 (J-25721-A) Sliding hammer	Remove oil pump assembly a: 179 mm (7.05 in) b: 70 mm (2.76 in) c: 40 mm (1.57 in) d: M12X1.75P

# PREPARATION

## < PREPARATION >

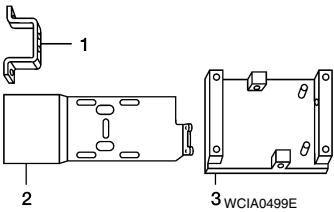
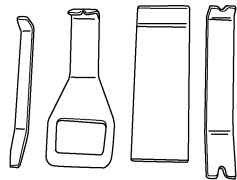
Tool number (TechMate No.) Tool name	Description
<p>— (J-47002) Transmission jack adapter kit</p> <p>1. — (J-47002-2) Center bracket</p> <p>2. — (J-47002-3) Adapter plate</p> <p>3. — (J-47002-4) Adapter block</p>	<p>Assist in removal of transmission and transfer case as one assembly using only one transmission jack.</p> 
<p>— (J-46534) Trim Tool Set</p>	<p>For removing trim</p>  <p style="text-align: center;">AWJIA0483ZZ</p>

## Commercial Service Tool

INFOID:000000009885896

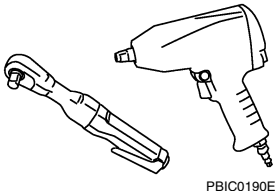
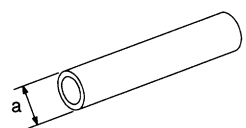
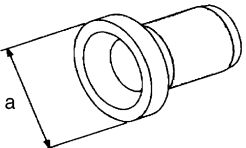
Tool name	Description
<p>Power tool</p>	<p>Loosening bolts and nuts</p>  <p style="text-align: center;">PBIC0190E</p>
<p>Drift</p>	<p>Installing manual shaft seals <b>a: 22 mm (0.87 in) dia.</b></p>  <p style="text-align: center;">NT083</p>
<p>Drift</p>	<p>Installing rear oil seal (4WD models) <b>a: 64 mm (2.52 in) dia.</b></p>  <p style="text-align: center;">SCIA5338E</p>

# A/T FLUID

< PERIODIC MAINTENANCE >

## PERIODIC MAINTENANCE

### A/T FLUID

#### Checking the A/T Fluid (ATF)

INFOID:000000009885897

**CAUTION:**

If using the vehicle for towing, the A/T fluid must be replaced as specified. Refer to [MA-9, "FOR NORTH AMERICA : Introduction of Periodic Maintenance"](#) (United States and Canada) [MA-12, "FOR MEXICO : Introduction of Periodic Maintenance"](#) (Mexico).

1. Before driving, the A/T fluid level can be checked at A/T fluid temperatures of 30° to 50° C (86° to 122° F) using the "COLD" range on the A/T fluid level gauge as follows:
  - a. Park the vehicle on a level surface and set the parking brake.
  - b. Start the engine and move the shift selector through each gear position. Move the shift selector into the "P" position.
  - c. Check the A/T fluid level with the engine idling.
  - d. Remove the A/T fluid level gauge and wipe it clean with a lint-free paper.

**CAUTION:**

When wiping the A/T fluid from the A/T fluid level gauge, always use a lint-free paper, not a cloth.

- e. Re-insert the A/T fluid level gauge into the A/T fluid charging pipe until the cap contacts the top of the A/T fluid charging pipe as shown.

**CAUTION:**

To check A/T fluid level, insert the A/T fluid level gauge until the cap contacts the top of the A/T fluid charging pipe, with the gauge reversed from the normal inserted position.

- f. Remove the A/T fluid level gauge and note the A/T fluid level. If the A/T fluid level is at low side of range, add A/T fluid to the transmission through the A/T fluid charging pipe.

**CAUTION:**

Do not overfill the transmission with A/T fluid.

- g. Install the A/T fluid level gauge and the A/T fluid level gauge bolt.

**A/T fluid level gauge bolt** : Refer to [TM-211, "Removal and Installation \(2WD\)"](#) or [TM-213, "Removal and Installation \(4WD\)"](#)

2. Warm up the engine and transmission.
3. Check for any A/T fluid leaks.
4. Drive the vehicle to increase the A/T fluid temperature to 80° C (176° F).

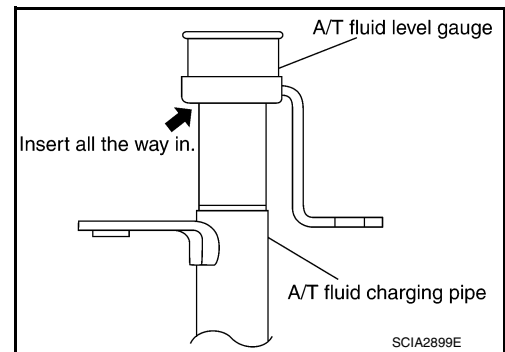
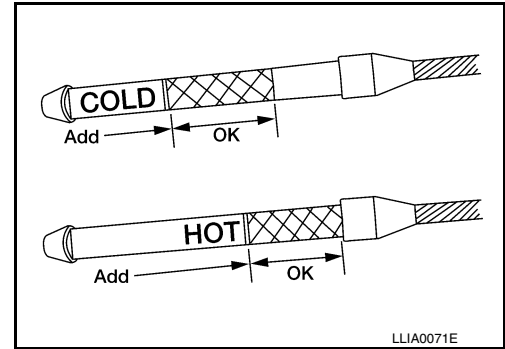

# A/T FLUID

## < PERIODIC MAINTENANCE >

- Allow the A/T fluid temperature to fall to approximately 65°C (149°F). Use the CONSULT to monitor the A/T fluid temperature as follows:

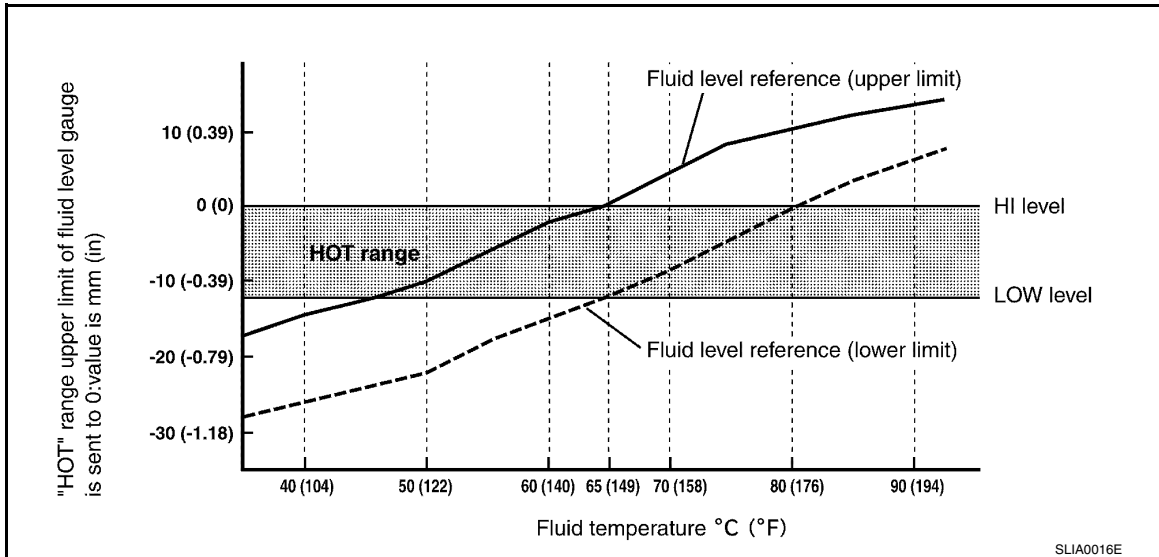

### NOTE:

The A/T fluid level will be significantly affected by the A/T fluid temperature as shown. Therefore monitor the A/T fluid temperature data using the CONSULT.

- Connect CONSULT to data link connector.
  - Select "MAIN SIGNALS" in "DATA MONITOR" mode for "A/T" with CONSULT.
  - Read out the value of "ATF TEMP 1".
- Re-check the A/T fluid level at A/T fluid temperatures of approximately 65°C (149°F) using the "HOT" range on the A/T fluid level gauge as shown. The HOT range is between 50° - 80° C (122° - 176° F).

### CAUTION:

- When wiping the A/T fluid from the A/T fluid level gauge, always use lint-free paper, not a cloth.

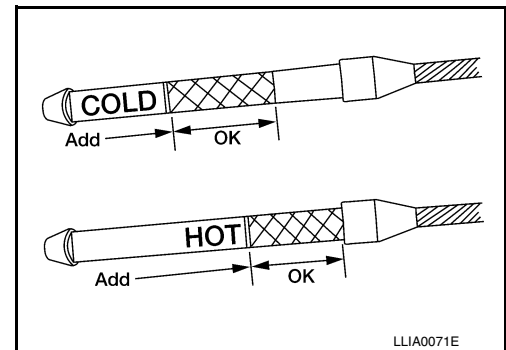

- To check the A/T fluid level, insert the A/T fluid level gauge until the cap contacts the top of the A/T fluid charging pipe, with the gauge reversed from the normal inserted position as shown.

- Check the A/T fluid condition.
  - If the A/T fluid is very dark or has some burned smell, there may be an internal problem with the transmission. Refer to [TM-176, "A/T Fluid Cooler Cleaning"](#). Flush the transmission cooling system after repairing the transmission.
  - If the A/T fluid contains frictional material (clutches, bands, etc.), replace the radiator and flush the transmission cooler lines using cleaning solvent and compressed air after repairing the transmission.

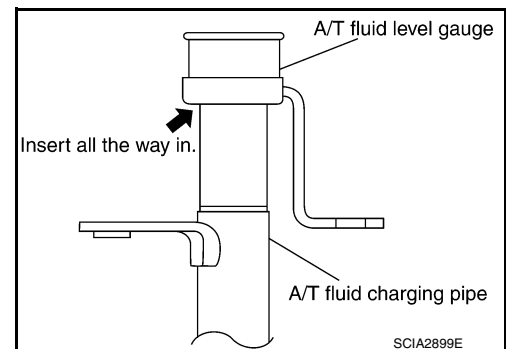

- Install the A/T fluid level gauge in the A/T fluid charging pipe.
- Tighten the A/T fluid level gauge bolt to specification.

**A/T fluid level gauge bolt** : Refer to [TM-211, "Removal and Installation \(2WD\)"](#) or [TM-213, "Removal and Installation \(4WD\)"](#)

# A/T FLUID

< PERIODIC MAINTENANCE >

## Changing the A/T Fluid (ATF)

INFOID:000000009885898

### CAUTION:

If using the vehicle for towing, the A/T fluid must be replaced as specified. Refer to [MA-9, "FOR NORTH AMERICA : Introduction of Periodic Maintenance"](#) (United States and Canada) [MA-12, "FOR MEXICO : Introduction of Periodic Maintenance"](#) (Mexico).

1. Drive the vehicle to warm up the A/T fluid to approximately 80° C (176° F).
2. Stop the engine.
3. Remove the A/T fluid level gauge.
4. Drain the A/T fluid from the drain plug hole, then install the drain plug with a new gasket. Refill the transmission with new A/T fluid. Always refill with the same volume as the drained A/T fluid. Use the A/T fluid level gauge to check the A/T fluid level as shown. Add A/T fluid as necessary.

**Drain plug** : Refer to [TM-217, "Component"](#).

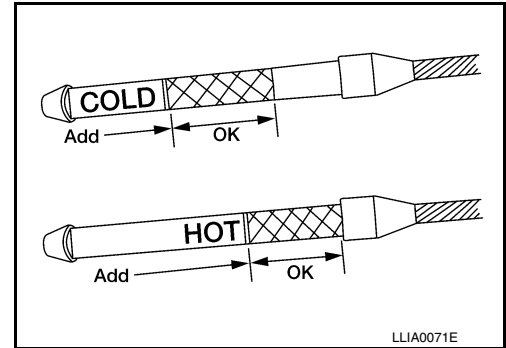

- To flush out the old A/T fluid from the transmission oil coolers, pour new A/T fluid into the A/T fluid charging pipe with the engine idling and at the same time drain the old A/T fluid from the auxiliary transmission oil cooler hose return line.
- When the color of the A/T fluid coming out of the auxiliary transmission oil cooler hose return line is about the same as the color of the new A/T fluid, flushing out the old A/T fluid is complete. The amount of new A/T fluid used for flushing should be 30% to 50% increase of the specified capacity.

**A/T fluid grade and capacity** : Refer to [MA-15, "FOR NORTH AMERICA : Fluids and Lubricants"](#) (United States and Canada) [MA-16, "FOR MEXICO : Fluids and Lubricants"](#) (Mexico).

### CAUTION:

- If Genuine NISSAN Matic S ATF is not available, Genuine NISSAN Matic J ATF may also be used.
  - Using ATF fluid other than Genuine NISSAN Matic S ATF or Matic J ATF will cause deterioration in driveability and A/T durability, and may damage the A/T, which is not covered by the warranty.
  - When filling the transmission with A/T fluid, do not spill the A/T fluid on any heat generating parts such as the exhaust parts.
  - Do not reuse the drain plug gasket.
5. Install the A/T fluid level gauge and tighten the A/T fluid level gauge bolt to specification.

**A/T fluid level gauge bolt** : Refer to [TM-211, "Removal and Installation \(2WD\)"](#) or [TM-213, "Removal and Installation \(4WD\)"](#).

6. Drive the vehicle to warm up the A/T fluid to approximately 80° C (176° F).
7. Check the fluid level and condition. If the A/T fluid is still dirty, repeat steps 2 through 6.

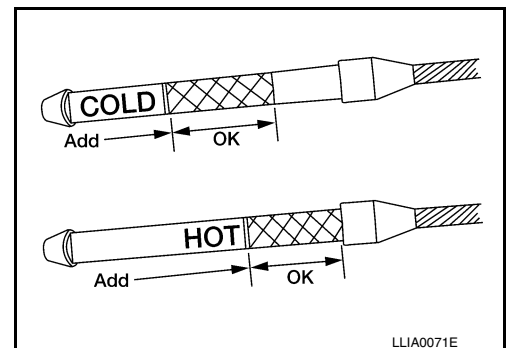

8. Install the A/T fluid level gauge in the A/T fluid charging pipe and install the A/T fluid level gauge bolt.

## A/T FLUID

### < PERIODIC MAINTENANCE >

---

9. Tighten the A/T fluid level gauge bolt to specification.

**A/T fluid level gauge bolt** : Refer to [TM-211, "Removal and Installation \(2WD\)"](#) or [TM-213, "Removal and Installation \(4WD\)"](#).

A

B

C

TM

E

F

G

H

I

J

K

L

M

N

O

P

# A/T FLUID COOLER

< PERIODIC MAINTENANCE >

## A/T FLUID COOLER

### A/T Fluid Cooler Cleaning

INFOID:000000009885899

Whenever an A/T is repaired, overhauled, or replaced, the A/T fluid cooler mounted in the radiator must be inspected and cleaned.

Metal debris and friction material, if present, can become trapped in the A/T fluid cooler. This debris can contaminate the newly serviced A/T or, in severe cases, can block or restrict the flow of A/T fluid. In either case, malfunction of the newly serviced A/T may result.

Debris, if present, may build up as A/T fluid enters the cooler inlet. It will be necessary to back flush the cooler through the cooler outlet in order to flush out any built up debris.

### A/T FLUID COOLER CLEANING PROCEDURE

1. Position a drain pan under the A/T inlet and outlet fluid cooler tube to cooler hose connection.
2. Put a different color matching mark on each cooler tube to cooler hose connection to aid in assembly.

**CAUTION:**

**Use paint to make the matching mark. Do not damage the tubes or hose.**

3. Disconnect the fluid cooler inlet and outlet rubber hoses from the steel cooler tubes.

**NOTE:**

Replace the cooler hoses if rubber material from the hose remains on the tube fitting.

4. Drain any A/T fluid from the cooler hose.

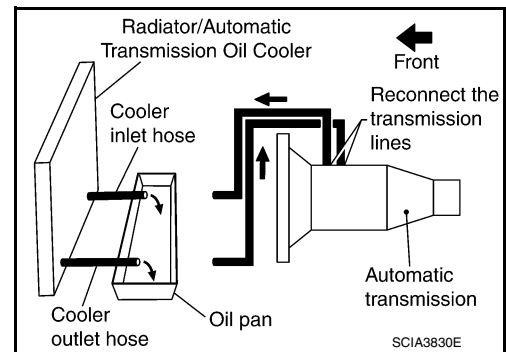

5. Insert the extension adapter hose of a can of Transmission Cooler Cleaner (Nissan P/N 999MP-AM006) into the cooler outlet hose.

**CAUTION:**

- Wear safety glasses and rubber gloves when spraying the Transmission Cooler Cleaner.
- Spray cooler cleaner only with adequate ventilation.
- Avoid contact with eyes and skin.
- Do not breath vapors or spray mist.

6. Hold the hose and can as high as possible and spray Transmission Cooler Cleaner in a continuous stream into the cooler outlet hose until fluid flows out of the cooler inlet hose for 5 seconds.

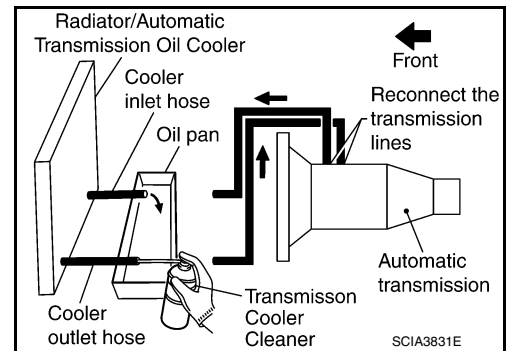

7. Insert the tip of an air gun into the end of the cooler outlet hose.
8. Wrap a shop rag around the tip of the air gun and the cooler outlet hose.

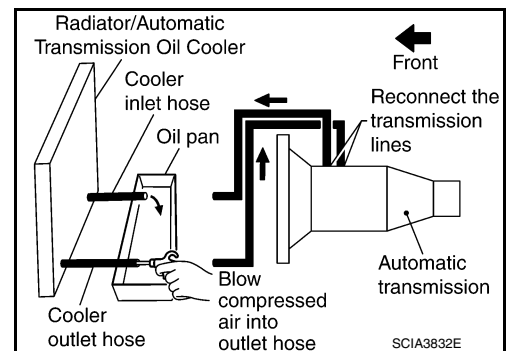

9. Blow compressed air regulated to 5 - 9 kg/cm<sup>2</sup> (70 - 130 psi) through the cooler outlet hose for 10 seconds to force out any remaining fluid.

10. Repeat steps 5 through 9 three additional times.

11. Position an oil pan under the banjo bolts that connect the fluid cooler tubes to the A/T.

12. Remove the banjo bolts.



## A/T FLUID COOLER

### < PERIODIC MAINTENANCE >

13. Flush each steel line from the cooler side back toward the A/T by spraying Transmission Cooler Cleaner in a continuous stream for 5 seconds.
14. Blow compressed air regulated to 5 - 9 kg/cm<sup>2</sup> (70 - 130 psi) through each steel line from the cooler side back toward the A/T for 10 seconds to force out any remaining fluid.
15. Ensure all debris is removed from the steel cooler lines.
16. Ensure all debris is removed from the banjo bolts and fittings.
17. Perform A/T fluid cooler diagnosis.

### A/T FLUID COOLER DIAGNOSIS PROCEDURE

#### NOTE:

Insufficient cleaning of the cooler inlet hose exterior may lead to inaccurate debris identification.

1. Position a drain pan under the A/T inlet and outlet fluid cooler tube to cooler hose connection.
2. Clean the exterior and tip of the cooler inlet hose.
3. Put a different color matching mark on each cooler tube to cooler hose connection to aid in assembly.

#### CAUTION:

**Use paint to make the matching mark. Do not damage the tubes or hose.**

4. Disconnect the fluid cooler inlet and outlet rubber hoses from the steel cooler tubes.

#### NOTE:

Replace the cooler hoses if rubber material from the hose remains on the tube fitting.

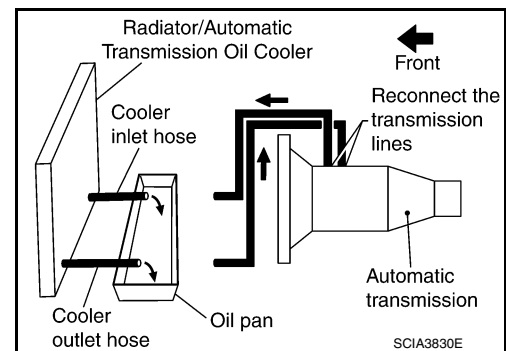

5. Insert the extension adapter hose of a can of Transmission Cooler Cleaner (Nissan P/N 999MP-AM006) into the cooler outlet hose.

#### CAUTION:

- Wear safety glasses and rubber gloves when spraying the Transmission Cooler Cleaner.
- Spray cooler cleaner only with adequate ventilation.
- Avoid contact with eyes and skin.
- Do not breath vapors or spray mist.

6. Hold the hose and can as high as possible and spray Transmission Cooler Cleaner in a continuous stream into the cooler outlet hose until fluid flows out of the cooler inlet hose for 5 seconds.

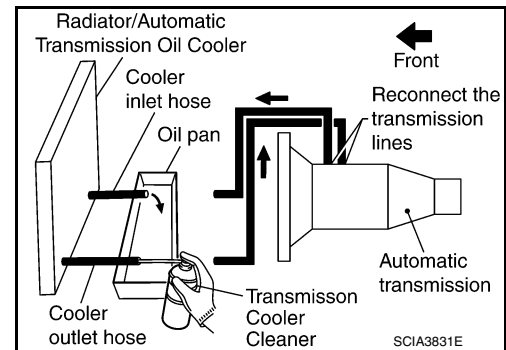

7. Tie a common white, basket-type coffee filter to the end of the cooler inlet hose.

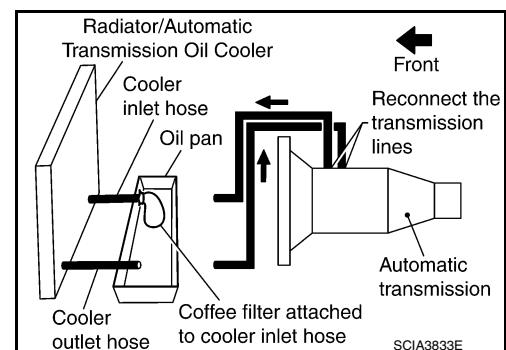

# A/T FLUID COOLER

## < PERIODIC MAINTENANCE >

8. Insert the tip of an air gun into the end of the cooler outlet hose.
9. Wrap a shop rag around the air gun tip and end of cooler outlet hose.
10. Blow compressed air regulated to 5 - 9 kg/cm<sup>2</sup> (70 - 130 psi) through the cooler outlet hose to force any remaining A/T fluid into the coffee filter.
11. Remove the coffee filter from the end of the cooler inlet hose.
12. Perform A/T fluid cooler inspection.

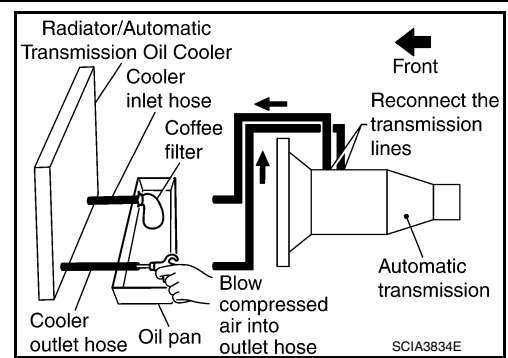

## A/T FLUID COOLER INSPECTION PROCEDURE

1. Inspect the coffee filter for debris.
  - a. If small metal debris less than 1mm (0.040 in) in size or metal powder is found in the coffee filter, this is normal. If normal debris is found, the A/T fluid cooler/radiator can be re-used and the procedure is ended.
  - b. If one or more pieces of debris are found that are over 1mm (0.040 in) in size and/or peeled clutch facing material is found in the coffee filter, the fluid cooler is not serviceable. The A/T fluid cooler/radiator must be replaced and the inspection procedure is ended. Refer to [CO-15. "Removal and Installation"](#).

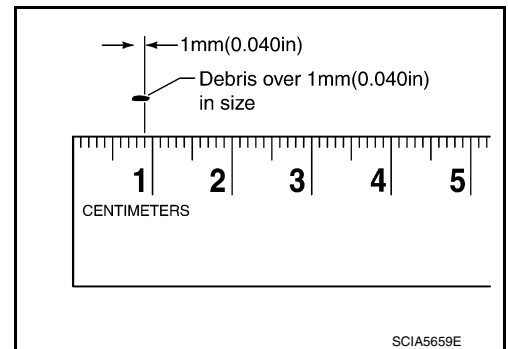
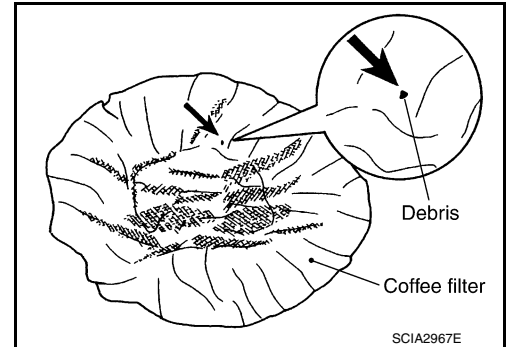

## A/T FLUID COOLER FINAL INSPECTION

After performing all procedures, ensure that all remaining oil is cleaned from all components.

### Inspection

INFOID:000000009885900

After performing all procedures, ensure that all remaining oil is cleaned from all components.

# STALL TEST

< PERIODIC MAINTENANCE >

## STALL TEST

### Inspection and Judgment

INFOID:000000009885901

#### A/T FLUID CHECK

Fluid Leakage and Fluid Level Check

- Inspect for fluid leakage and check the fluid level. Refer to [TM-172. "Checking the A/T Fluid \(ATF\)".](#)

Fluid Condition Check

Inspect the fluid condition.

Fluid condition	Conceivable Cause	Required Operation
Varnished (viscous varnish state)	Clutch, brake scorched	Replace the ATF and check the A/T main unit and the vehicle for malfunctions (wire harnesses, cooler pipes, etc.)
Milky white or cloudy	Water in the fluid	Replace the ATF and check for places where water is getting in.
Large amount of metal powder mixed in	Unusual wear of sliding parts within A/T	Replace the ATF and check for improper operation of the A/T.

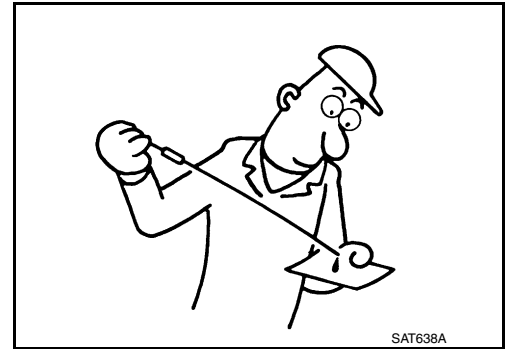

## STALL TEST

### Stall Test Procedure

1. Inspect the amount of engine oil. Replenish the engine oil if necessary.
2. Drive for about 10 minutes to warm up the vehicle so that the A/T fluid temperature is 50 to 80°C (122 to 176°F). Inspect the amount of ATF. Replenish if necessary.

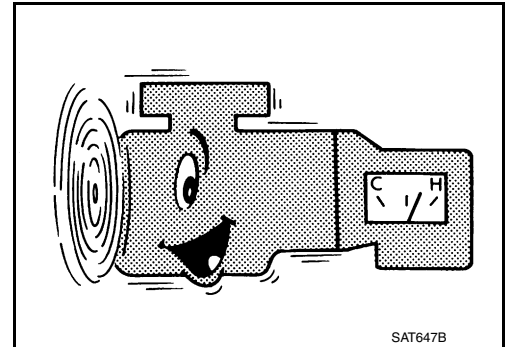

3. Securely engage the parking brake so that the tires do not turn.

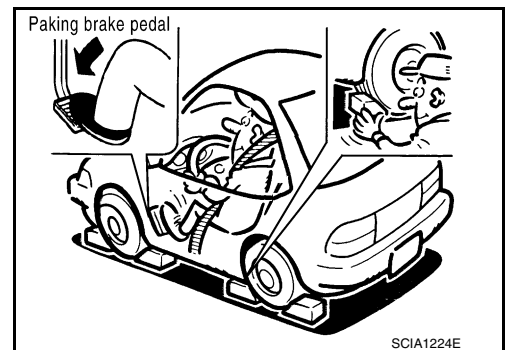

A  
B  
C  
TM  
E  
F  
G  
H  
I  
J  
K  
L  
M  
N  
O  
P

# STALL TEST

## < PERIODIC MAINTENANCE >

4. Engine start, apply foot brake, and place selector lever in "D" position.
5. While holding down the foot brake, gradually press down the accelerator pedal.
6. Quickly read off the stall speed, then quickly remove your foot from the accelerator pedal.

**CAUTION:**

**Do not hold down the accelerator pedal for more than 5 seconds during this test.**

**Stall speed** : Refer to [TM-289, "Stall Speed"](#).

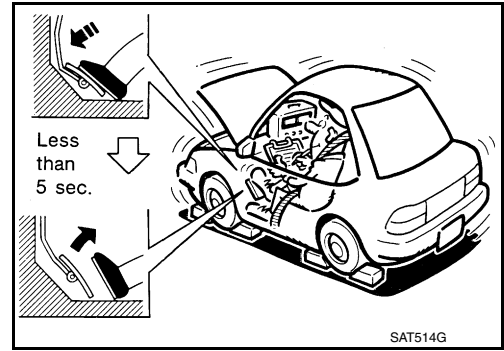

7. Move the selector lever to the "N" position.
8. Cool down the ATF.  
**CAUTION:**  
**Run the engine at idle for at least one minute.**

### Judgment of Stall Test

	Selector lever position		Expected problem location
	D	R	
Stall rotation	H	O	<ul style="list-style-type: none"> <li>• Forward brake</li> <li>• Forward one-way clutch</li> <li>• 1st one-way clutch</li> <li>• 3rd one-way clutch</li> </ul>
	O	H	<ul style="list-style-type: none"> <li>• Reverse brake</li> </ul>
	L	L	<ul style="list-style-type: none"> <li>• Engine and torque converter one-way clutch</li> </ul>
	H	H	<ul style="list-style-type: none"> <li>• Line pressure low</li> </ul>

O: Stall speed within standard value position

H: Stall speed higher than standard value

L: Stall speed lower than standard value

### Stall test standard value position

Does not shift-up D position 1 → 2	Slipping in 2GR, 3GR, 4GR	Direct clutch slippage
Does not shift-up D position 2 → 3	Slipping in 3GR, 4GR, 5GR	High and low reverse clutch slippage
Does not shift-up D position 3 → 4	Slipping in 4GR, 5GR	Input clutch slippage
Does not shift-up D position 4 → 5	Slipping in 5GR	Front brake slippage

# LINE PRESSURE TEST

< PERIODIC MAINTENANCE >

## LINE PRESSURE TEST

### Inspection and Judgment

INFOID:000000009885902

### LINE PRESSURE TEST

#### Line Pressure Test Port

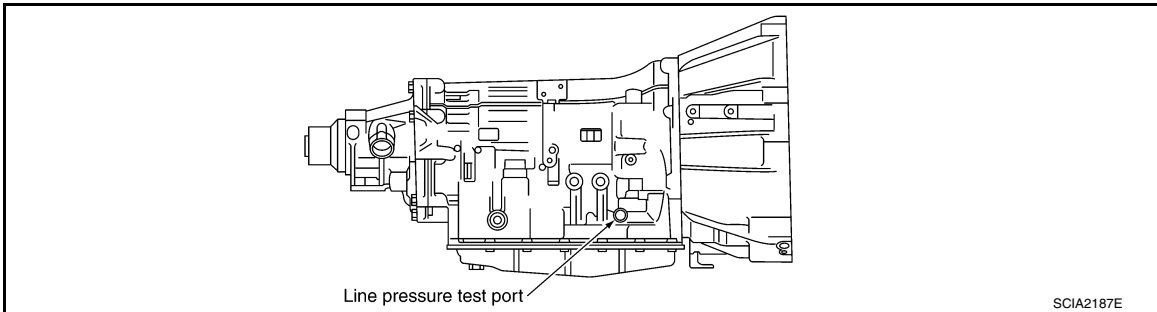

#### Line Pressure Test Procedure

1. Inspect the amount of engine oil and replenish if necessary.
2. Drive the car for about 10 minutes to warm it up so that the ATF reaches in range of 50 to 80°C (122 to 176°F), then inspect the amount of ATF and replenish if necessary.

**NOTE:**

The automatic fluid temperature rises in range of 50 to 80°C (122 to 176°F) during 10 minutes of driving.

3. After warming up remove the oil pressure detection plug and install the Tool.

**CAUTION:**

When using the oil pressure gauge, be sure to use the O-ring attached to the oil pressure detection plug.

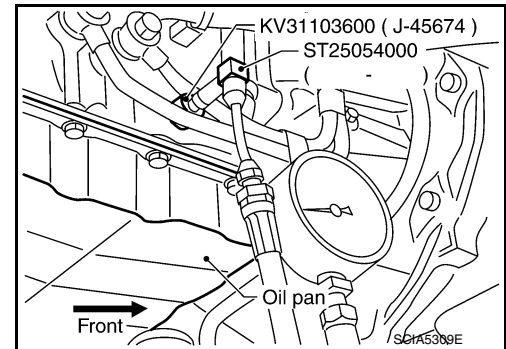

4. Securely engage the parking brake so that the tires do not turn.

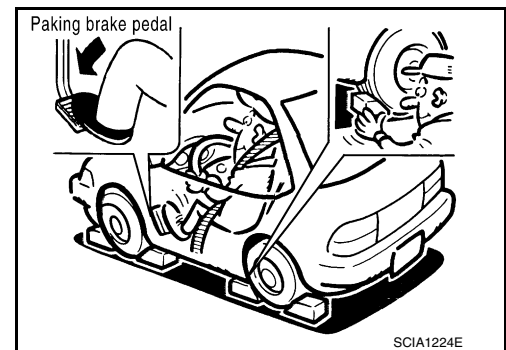

A  
B  
C  
TM  
E  
F  
G  
H  
I  
J  
K  
L  
M  
N  
O  
P

# LINE PRESSURE TEST

## < PERIODIC MAINTENANCE >

5. Start the engine, then measure the line pressure at both idle and the stall speed.

**CAUTION:**

- Keep the brake pedal pressed all the way down during measurement.
- When measuring the line pressure at the stall speed, refer to [TM-77, "Description"](#).

**Line pressure** : Refer to [TM-289, "Line Pressure"](#).

6. After the measurements are complete, install the oil pressure detection plug and tighten to the regulation torque below.

**Oil pressure detection plug** : 7.3 N·m (0.74 kg·m, 65 in·lb)

**CAUTION:**

**Do not reuse the O-ring.**

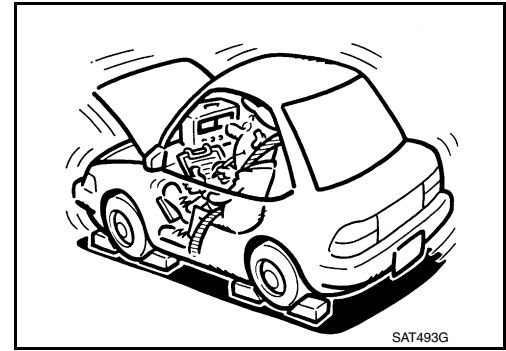

### Judgment of Line Pressure Test

Judgment		Possible cause
Idle speed	Low for all positions (P, R, N, D)	Possible causes include malfunctions in the pressure supply system and low oil pump output. For example <ul style="list-style-type: none"> <li>• Oil pump wear</li> <li>• Pressure regulator valve or plug sticking or spring fatigue</li> <li>• Oil strainer ⇒ oil pump ⇒ pressure regulator valve passage oil leak</li> <li>• Engine idle speed too low</li> </ul>
	Only low for a specific position	Possible causes include an oil pressure leak in a passage or device related to the position after the pressure is distributed by the manual valve.
	High	Possible causes include a sensor malfunction or malfunction in the line pressure adjustment function. For example <ul style="list-style-type: none"> <li>• Accelerator pedal position signal malfunction</li> <li>• ATF temperature sensor malfunction</li> <li>• Line pressure solenoid malfunction (sticking in "OFF" state, filter clog, cut line)</li> <li>• Pressure regulator valve or plug sticking</li> </ul>
Stall speed	Oil pressure does not rise higher than the oil pressure for idle.	Possible causes include a sensor malfunction or malfunction in the pressure adjustment function. For example <ul style="list-style-type: none"> <li>• Accelerator pedal position signal malfunction</li> <li>• TCM breakdown</li> <li>• Line pressure solenoid malfunction (shorting, sticking in "ON" state)</li> <li>• Pressure regulator valve or plug sticking</li> <li>• Pilot valve sticking or pilot filter clogged</li> </ul>
	The pressure rises, but does not enter the standard position.	Possible causes include malfunctions in the pressure supply system and malfunction in the pressure adjustment function. For example <ul style="list-style-type: none"> <li>• Accelerator pedal position signal malfunction</li> <li>• Line pressure solenoid malfunction (sticking, filter clog)</li> <li>• Pressure regulator valve or plug sticking</li> <li>• Pilot valve sticking or pilot filter clogged</li> </ul>
	Only low for a specific position	Possible causes include an oil pressure leak in a passage or device related to the position after the pressure is distributed by the manual valve.

# ROAD TEST

< PERIODIC MAINTENANCE >

## ROAD TEST

### Description

INFOID:000000009885903

### ROAD TEST

- The road test inspects overall performance of the A/T and analyzes possible malfunction causes.
  - The road test is carried out in the following three stages.
1. Check before engine is started. Refer to [TM-183, "Check Before Engine Is Started"](#).
  2. Check at idle. Refer to [TM-183, "Check At Idle"](#).
  3. Cruise test
    - Inspect all the items from Part 1 to Part 3. Refer to [TM-184, "Cruise Test - Part 1"](#), [TM-186, "Cruise Test - Part 2"](#), [TM-186, "Cruise Test - Part 3"](#).
- Before beginning the road test, check the test procedure and inspection items.
  - Test all inspection items until the symptom is uncovered. Diagnose NG items when all road tests are complete.

### Check Before Engine Is Started

INFOID:000000009885904

#### 1.CHECK AT CHECK INDICATOR LAMP

1. Park vehicle on level surface.
2. Move selector lever to "P" position.
3. Turn ignition switch to "OFF" position and wait at least 10 seconds.
4. Turn ignition switch to "ON" position. (Do not start engine.)

#### Does AT CHECK indicator lamp light up for about 2 seconds?

- YES >> 1. Turn ignition switch to "OFF" position.  
2. Carry out the self-diagnostics and record all NG items on the diagnostics worksheet. Refer to [TM-38, "CONSULT Function \(TRANSMISSION\)"](#).  
3. Go to [TM-183, "Check At Idle"](#).
- NO >> Stop the road test and go to [TM-143, "Symptom Table"](#).

### Check At Idle

INFOID:000000009885905

#### 1.CHECK STARTING THE ENGINE

1. Park vehicle on level surface.
2. Move selector lever to "P" or "N" position.
3. Turn ignition switch to "OFF" position.
4. Turn ignition switch to "START" position.

#### Does the engine start?

- YES >> GO TO 2.
- NO >> Stop the road test and go to [TM-143, "Symptom Table"](#).

#### 2.CHECK STARTING THE ENGINE

1. Turn ignition switch to "ON" position.
2. Move selector lever in "D", "4", "3", "2", "1" or "R" position.
3. Turn ignition switch to "START" position.

#### Does the engine start in either position?

- YES >> Stop the road test and go to [TM-143, "Symptom Table"](#).
- NO >> GO TO 3.

#### 3.CHECK "P" POSITION FUNCTIONS

1. Move selector lever to "P" position.
2. Turn ignition switch to "OFF" position.
3. Release the parking brake.
4. Push the vehicle forward or backward.
5. Engage the parking brake.

# ROAD TEST

## < PERIODIC MAINTENANCE >

---

When you push the vehicle with disengaging the parking brake, does it move?

- YES >> Record the malfunction, GO TO 4.
- NO >> GO TO 4.

### 4.CHECK "N" POSITION FUNCTIONS

---

1. Start the engine.
2. Move selector lever to "N" position.
3. Release the parking brake.

Does vehicle move forward or backward?

- YES >> Record the malfunction, GO TO 5.
- NO >> GO TO 5.

### 5.CHECK SHIFT SHOCK

---

1. Engage the brake.
2. Move selector lever to "D" position.

When the transmission is shifted from "N" to "D", is there an excessive shock?

- YES >> Record the malfunction, GO TO 6.
- NO >> GO TO 6.

### 6.CHECK "R" POSITION FUNCTIONS

---

1. Engage the brake.
2. Move selector lever to "R" position.
3. Release the brake for 4 to 5 seconds.

Does the vehicle creep backward?

- YES >> GO TO 7.
- NO >> Record the malfunction, GO TO 7.

### 7.CHECK "D" POSITION FUNCTIONS

---

Inspect whether the vehicle creeps forward when the transmission is put into the "D" position.

Does the vehicle creep forward in the "D" positions?

- YES >> Go to [TM-184, "Cruise Test - Part 1"](#).
- NO >> Record the malfunction and go to [TM-184, "Cruise Test - Part 1"](#).

## Cruise Test - Part 1

INFOID:000000009885906

### 1.CHECK STARTING OUT FROM D1

---

1. Drive the vehicle for about 10 minutes to warm up the engine oil and ATF.  
Appropriate temperature for the ATF: 50 - 80°C (122 - 176°F)
2. Park the vehicle on a level surface.
3. Move selector lever to "P" position.
4. Start the engine.
5. Move selector lever to "D" position.
6. Press the accelerator pedal about half way down to accelerate the vehicle.

#### With CONSULT

Read off the gear positions.

Starts from D1?

- YES >> GO TO 2.
- NO >> Record the malfunction, GO TO 2.

### 2.CHECK SHIFT-UP D1 → D2

---

Press down the accelerator pedal about half way and inspect if the vehicle shifts up (D1 → D2) at the appropriate speed.

- Refer to [TM-288, "Vehicle Speed at Which Gear Shifting Occurs"](#).

#### With CONSULT

Read the gear position, throttle degree of opening, and vehicle speed.

Does the A/T shift-up D1 → D2 at the correct speed?

- YES >> GO TO 3.



# ROAD TEST

## < PERIODIC MAINTENANCE >

NO >> Record the malfunction, GO TO 3.

### 3.CHECK SHIFT-UP D2 → D3

Press down the accelerator pedal about half way and inspect if the vehicle shifts up (D2 → D3) at the appropriate speed.

• Refer to [TM-288. "Vehicle Speed at Which Gear Shifting Occurs"](#).

#### With CONSULT

Read the gear position, throttle degree of opening, and vehicle speed.

Does the A/T shift-up D2 → D3 at the correct speed?

YES >> GO TO 4.

NO >> Record the malfunction, GO TO 4.

### 4.CHECK SHIFT-UP D3 → D4

Press down the accelerator pedal about half way and inspect if the vehicle shifts up (D3 → D4) at the appropriate speed.

• Refer to [TM-288. "Vehicle Speed at Which Gear Shifting Occurs"](#).

#### With CONSULT

Read the gear position, throttle degree of opening, and vehicle speed.

Does the A/T shift-up D3 → D4 at the correct speed?

YES >> GO TO 5.

NO >> Record the malfunction, GO TO 5.

### 5.CHECK SHIFT-UP D4 → D5

Press down the accelerator pedal about half way and inspect if the vehicle shifts up (D4 → D5) at the appropriate speed.

• Refer to [TM-288. "Vehicle Speed at Which Gear Shifting Occurs"](#).

#### With CONSULT

Read the gear position, throttle degree of opening, and vehicle speed.

Does the A/T shift-up D4 → D5 at the correct speed?

YES >> GO TO 6.

NO >> Record the malfunction, GO TO 6.

### 6.CHECK LOCK-UP

When releasing accelerator pedal from D5, check lock-up from D5 to L/U.

• Refer to [TM-289. "Vehicle Speed at Which Lock-up Occurs/Releases"](#).

#### With CONSULT

Select "TCC SOLENOID" with the "MAIN SIGNAL" mode for "TRANSMISSION".

Does it lock-up?

YES >> GO TO 7.

NO >> Record the malfunction, GO TO 7.

### 7.CHECK LOCK-UP HOLD

Check hold lock-up.

#### With CONSULT

Select "TCC SOLENOID" with the "MAIN SIGNAL" mode for "TRANSMISSION".

Does it maintain lock-up status?

YES >> GO TO 8.

NO >> Record the malfunction, GO TO 8.

### 8.CHECK LOCK-UP RELEASE

Check lock-up cancellation by depressing brake pedal lightly to decelerate.

#### With CONSULT

Select "TCC SOLENOID" with the "MAIN SIGNAL" mode for "TRANSMISSION".

Does lock-up cancel?

YES >> GO TO 9.

NO >> Record the malfunction, GO TO 9.

A  
B  
C  
TM  
E  
F  
G  
H  
I  
J  
K  
L  
M  
N  
O  
P

# ROAD TEST

< PERIODIC MAINTENANCE >

---

## 9. CHECK SHIFT-DOWN D5 → D4

---

Decelerate by pressing lightly on the brake pedal.

### With CONSULT

Read the gear position and engine speed.

When the A/T shift-down D5 → D4, does the engine speed drop smoothly back to idle?

- YES >> 1. Stop the vehicle.  
2. Go to [TM-186, "Cruise Test - Part 2"](#).  
NO >> Record the malfunction, Go to [TM-186, "Cruise Test - Part 2"](#).

## Cruise Test - Part 2

INFOID:000000009885907

### 1. CHECK SHIFT-UP D1 → D2

---

Press the accelerator pedal down all the way and inspect whether or not the transmission shifts up (D1 → D2) at the correct speed.

- Refer to [TM-288, "Vehicle Speed at Which Gear Shifting Occurs"](#).

### With CONSULT

Read the gear position, throttle position and vehicle speed.

Does the A/T shift-up D1 → D2 at the correct speed?

- YES >> GO TO 2.  
NO >> Record the malfunction, GO TO 2.

### 2. CHECK SHIFT-UP D2 → D3

---

Press the accelerator pedal down all the way and inspect whether or not the transmission shifts up (D2 → D3) at the correct speed.

- Refer to [TM-288, "Vehicle Speed at Which Gear Shifting Occurs"](#).

### With CONSULT

Read the gear position, throttle position and vehicle speed.

Does the A/T shift-up D2 → D3 at the correct speed?

- YES >> GO TO 3.  
NO >> Record the malfunction, GO TO 3.

### 3. CHECK SHIFT-UP D3 → D4 AND ENGINE BRAKE

---

When the transmission changes speed D3 → D4, return the accelerator pedal.

Does the A/T shift-up D3 → D4 and apply the engine brake?

- YES >> 1. Stop the vehicle.  
2. See [TM-186, "Cruise Test - Part 3"](#).  
NO >> Record the malfunction and go to [TM-186, "Cruise Test - Part 3"](#).

## Cruise Test - Part 3

INFOID:000000009885908

### 1. CHECK VEHICLE EQUIPMENT

---

Check A/T shift selector type.

Floor shift or column shift?

- Column shift >> GO TO 2.  
Floor shift >> GO TO 4.

### 2. MANUAL MODE FUNCTION

---

Move to manual mode from "D" position.

Does it switch to manual mode?

- YES >> GO TO 3.  
NO >> Record the malfunction, GO TO 3.

### 3. CHECK SHIFT-DOWN

---

During manual mode driving, move gear selector from M5 → M4 → M3 → M2 → M1.

### With CONSULT

# ROAD TEST

## < PERIODIC MAINTENANCE >

---

Read the gear position.

Is downshifting correctly performed?

YES >> GO TO 5.

NO >> Record the malfunction, GO TO 5.

### 4.CHECK SHIFT-DOWN

---

During D5 driving, move gear selector from D → 4 → 3 → 2 → 1.

 **With CONSULT**

Read the gear position.

Is downshifting correctly performed?

YES >> GO TO 5.

NO >> Record the malfunction, GO TO 5.

### 5.CHECK ENGINE BRAKE

---

Does engine braking effectively reduce speed in M1 position (with manual mode) or 11 position (without manual mode)?

YES >> 1. Stop the vehicle.

2. Carry out the self-diagnostics. Refer to [TM-38. "CONSULT Function \(TRANSMISSION\)".](#)

NO >> Record the malfunction, then continue the trouble diagnosis.

A

B

C

TM

E

F

G

H

I

J

K

L

M

N

O

P

# SHIFT CONTROL SYSTEM

< REMOVAL AND INSTALLATION >

## REMOVAL AND INSTALLATION

### SHIFT CONTROL SYSTEM

Exploded View

INFOID:000000009885909

Floor shift models

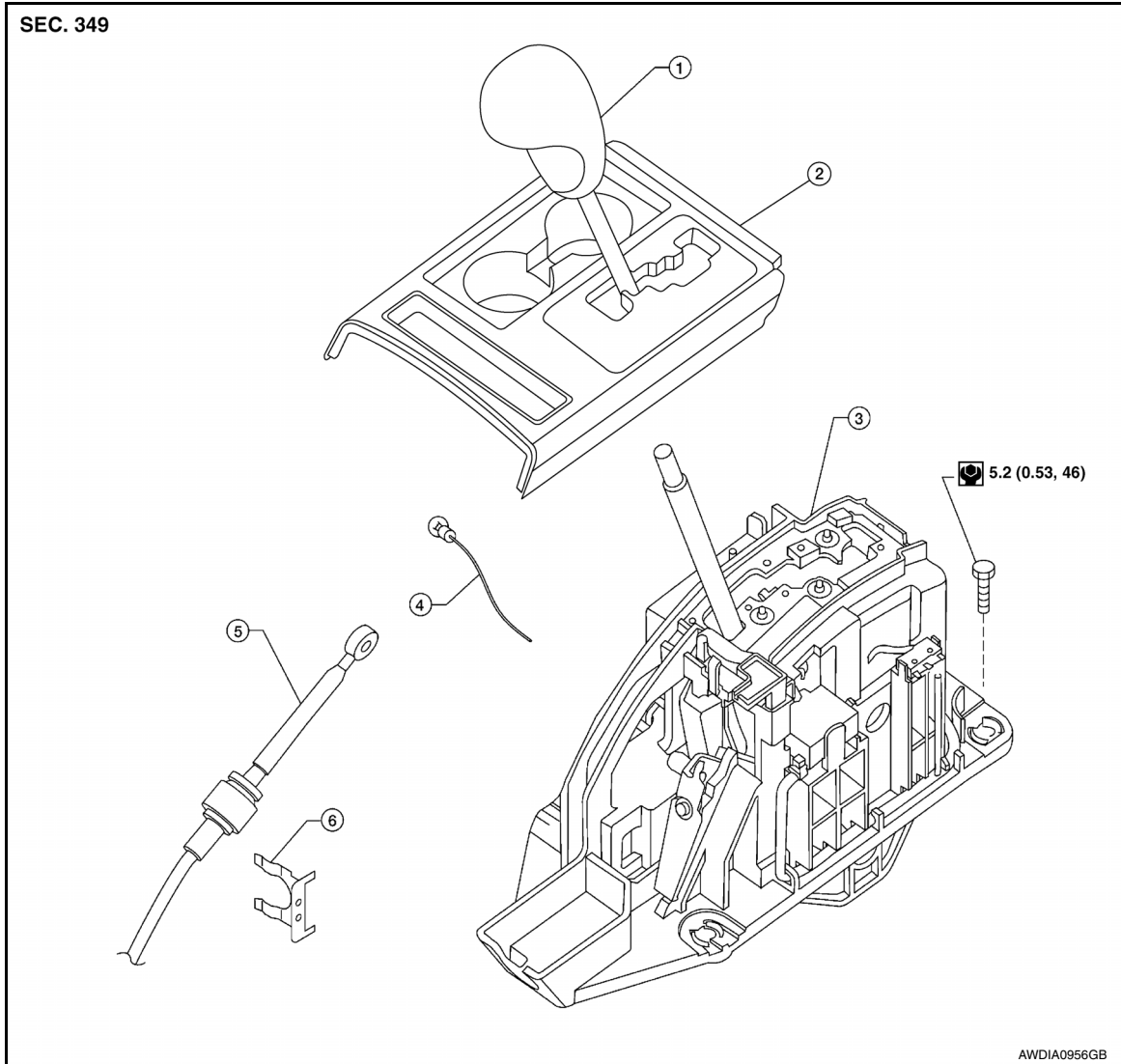

- |                          |                  |                                |
|--------------------------|------------------|--------------------------------|
| 1. Shift selector handle | 2. A/T finisher  | 3. A/T shift selector assembly |
| 4. Position lamp         | 5. Control cable | 6. Lock plate                  |

# SHIFT CONTROL SYSTEM

## < REMOVAL AND INSTALLATION >

### Column shift models

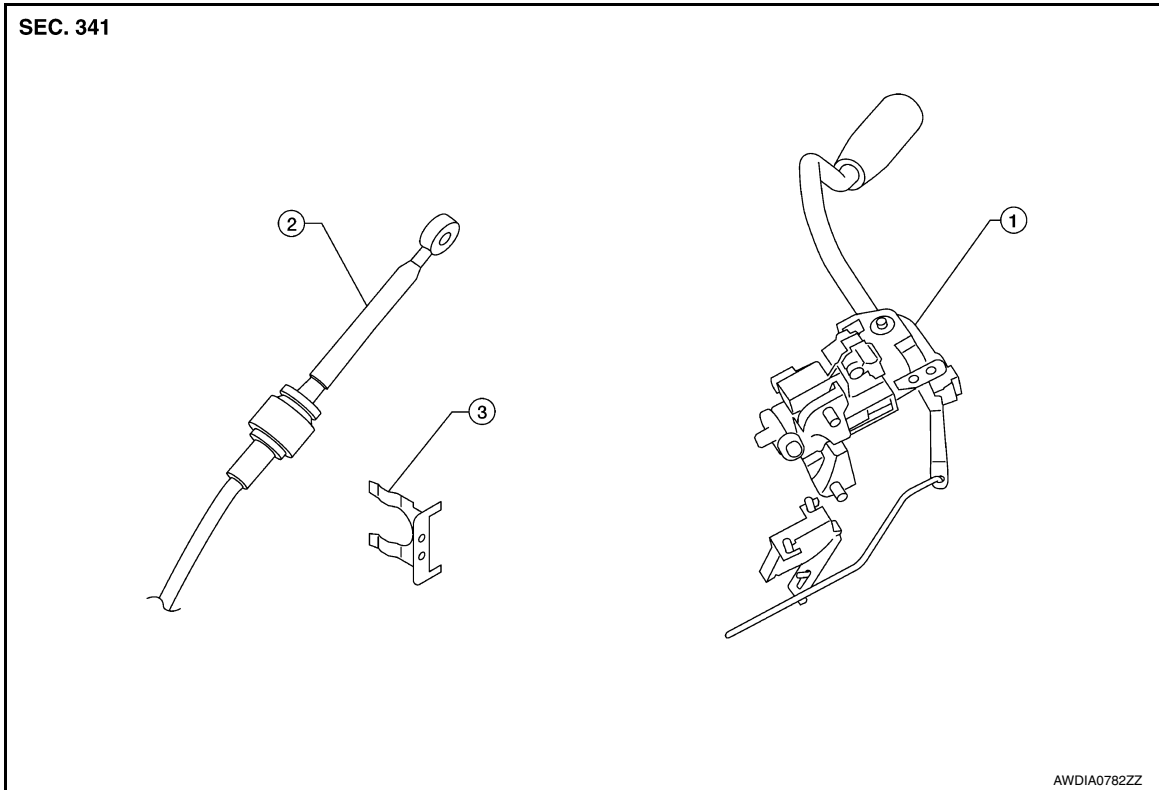

1. A/T shift selector

2. Control cable

3. A/T control cable lock plate clip

## A/T Shift Selector Removal and Installation

INFOID:000000009885910

### REMOVAL

#### Floor shift

1. Disconnect negative battery terminal. Refer to [PG-80, "Removal and Installation"](#).
2. Remove A/T finisher. Refer to [JP-18, "Removal and Installation"](#).
3. Disconnect A/T shift selector harness connector.
4. Disconnect control cable.
5. Remove A/T shift selector assembly.

#### Column shift

1. Remove the steering column. Refer to [ST-17, "Removal and Installation"](#).
2. Remove the control cable lock plate clip and remove the control cable from column shifter pin.
3. Remove the A/T shift selector.

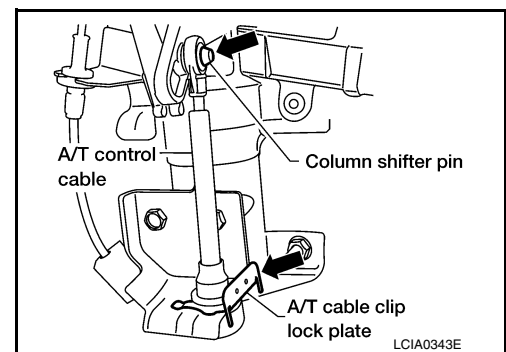

### INSTALLATION

Installation is in the reverse order of removal.

- After installation is completed, be sure to check A/T position and adjust as necessary. Refer to [TM-190, "Inspection and Adjustment"](#).

# SHIFT CONTROL SYSTEM

< REMOVAL AND INSTALLATION >

## Inspection and Adjustment

INFOID:000000009885911

### ADJUSTMENT OF A/T POSITION

1. Loosen nut of control cable.
2. Place transmission range switch and A/T shift selector in "P" position.
3. After pushing the control cable in the direction shown with a force of 9.8 N·m (1 kg-m, 2.2 lb-ft), release it. This is in the natural state, tighten control cable nut to specifications.

**Control cable nut : 14.6 N·m (1.5 kg-m, 11 ft-lb)**

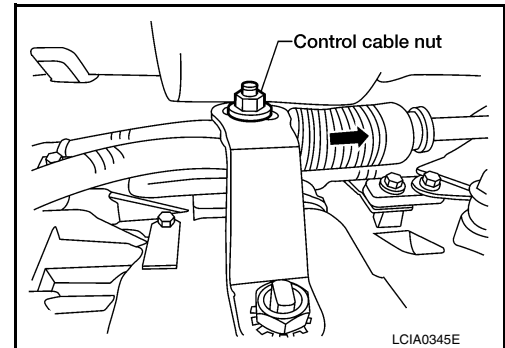

### CHECKING OF A/T POSITION

#### NOTE:

Following procedure will cover both column and floor shift selectors.

1. Place shift selector in "P" position, and turn ignition switch ON (engine stop).
2. Make sure shift selector can be moved from "P" position when brake pedal is depressed. Also make sure shift selector can be moved from "P" position only when brake pedal is depressed.
3. Move the shift selector and check for excessive effort, sticking, noise or rattle.
4. Confirm the shift selector stops at each position with the feel of engagement when it is moved through all the positions. Check whether or not the actual position the shift selector is in matches the position shown by the shift position indicator and the transmission body.
5. Confirm the back-up lamps illuminate only when shift selector is placed in the "R" position. Confirm the back-up lamps do not illuminate when shift selector is pushed against "R" position in the "P" or "N" position.
6. Confirm the engine can only be started with the shift selector in the "P" and "N" positions.
7. Make sure transmission is locked completely when shift selector is in the "P" position.

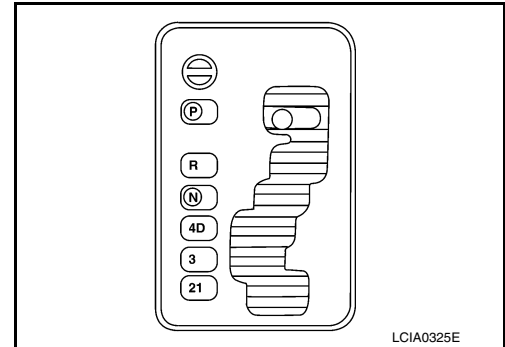

# CONTROL CABLE

< REMOVAL AND INSTALLATION >

## CONTROL CABLE

Exploded View

INFOID:000000009885912

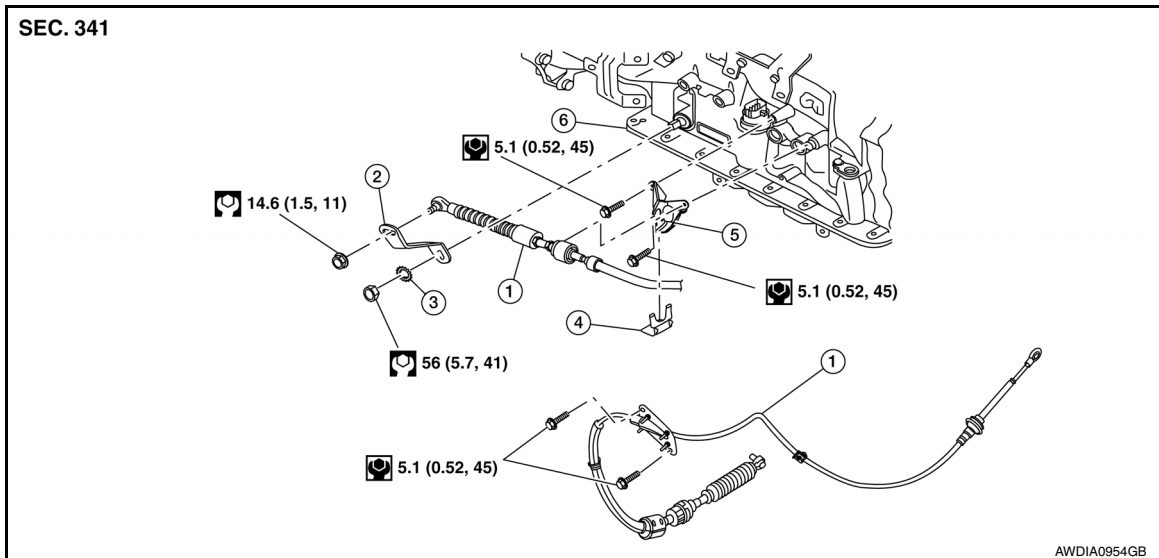

- |                  |                          |                 |
|------------------|--------------------------|-----------------|
| 1. Control cable | 2. Manual lever          | 3. Washer       |
| 4. Lock plate    | 5. Control cable bracket | 6. A/T assembly |

## Removal and Installation

INFOID:000000009885913

### REMOVAL

1. Remove the A/T shift selector assembly. Refer to [TM-189, "A/T Shift Selector Removal and Installation"](#).
2. Remove the heater and cooling unit assembly. Refer to [VTL-13, "Removal and Installation"](#).
3. Remove the control cable retainer bolts.
4. Remove the control cable nut (1) and disconnect the control cable from the manual lever (2).
5. Remove the control cable from the vehicle.

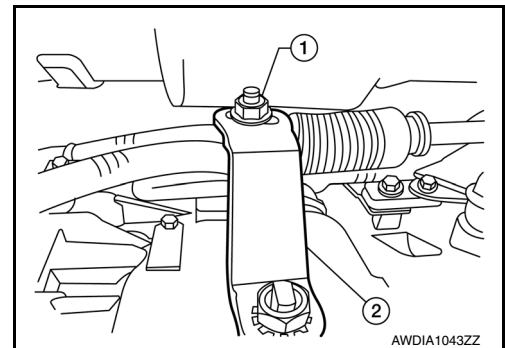

### INSTALLATION

- Installation is in the reverse order of removal.
- Tighten the control cable nut (1) to specification.

**Control cable nut (1) : 14.6 N·m (1.5 kg-m, 11 ft-lb)**

**(2) : Manual lever**

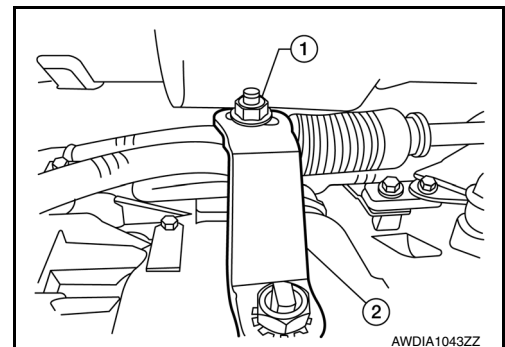

# KEY INTERLOCK CABLE

< REMOVAL AND INSTALLATION >

## KEY INTERLOCK CABLE

Component

INFOID:000000009885914

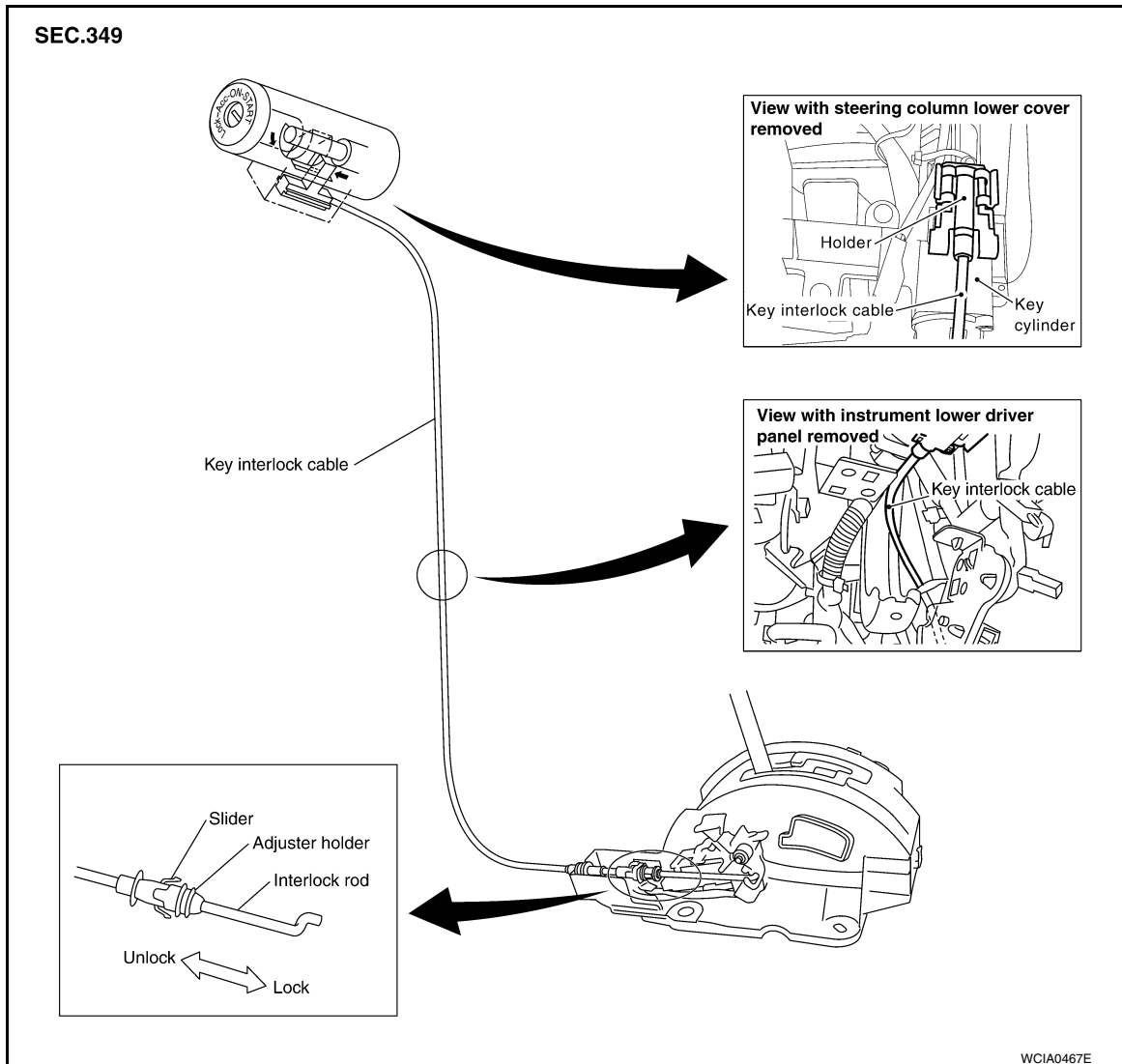

### CAUTION:

- Install key interlock cable in such a way that it will not be damaged by sharp bends, twists or interference with adjacent parts.
- After installing key interlock cable to A/T shift selector, make sure that casing cap and bracket are firmly secured in their positions. If casing cap can be removed with an external load of less than 39 N (4.0 kg, 8.8 lb), replace key interlock cable with new one.

### Removal and Installation

INFOID:000000009885915

#### REMOVAL (Floor shift models)



## KEY INTERLOCK CABLE

### < REMOVAL AND INSTALLATION >

1. Unlock slider from adjuster holder by squeezing lock tabs.
2. Remove casing cap from bracket of A/T shift selector assembly and remove interlock rod from adjuster holder.

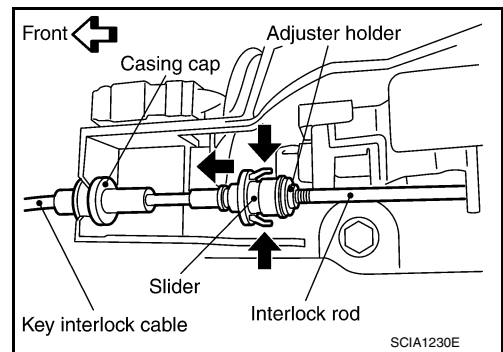

3. Remove holder from key cylinder and remove key interlock cable.

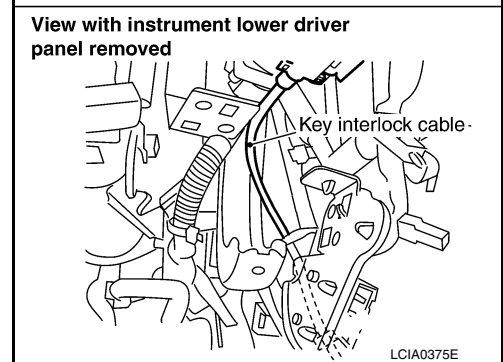
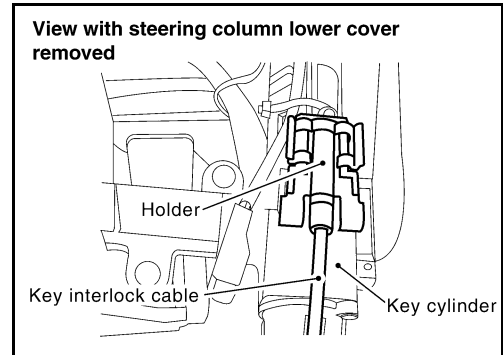

### REMOVAL (Column shift models)

1. Remove the instrument lower panel (LH). Refer to [IP-17, "Removal and Installation"](#).
2. Remove the knee protector.

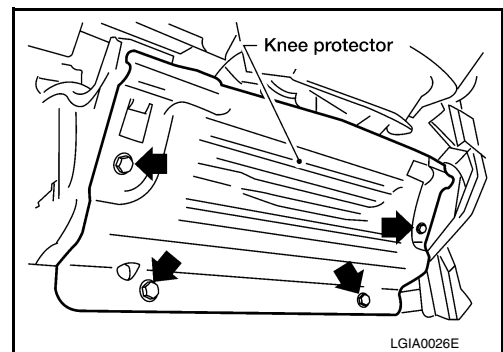

3. Disconnect shift lock cable.
4. Remove the key interlock cable.

### INSTALLATION (Floor shift models)

## KEY INTERLOCK CABLE

### < REMOVAL AND INSTALLATION >

1. Set key interlock cable to key cylinder and install holder.
2. Turn ignition key to "LOCK" position.
3. Set A/T shift selector to (P) position.

View with steering column lower cover removed

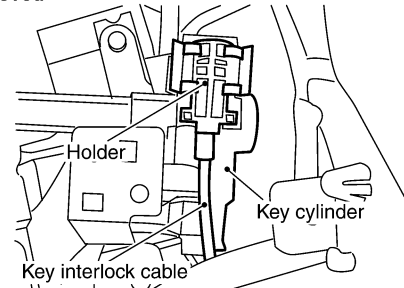

View with instrument lower driver panel removed

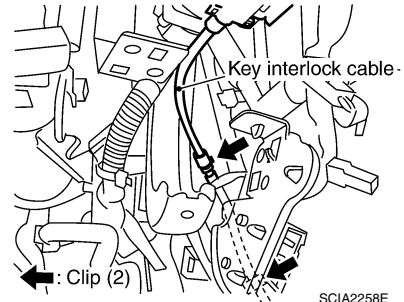

4. Insert interlock rod into adjuster holder.
5. Install casing cap to bracket.
6. Move slider in order to secure adjuster holder to interlock rod.

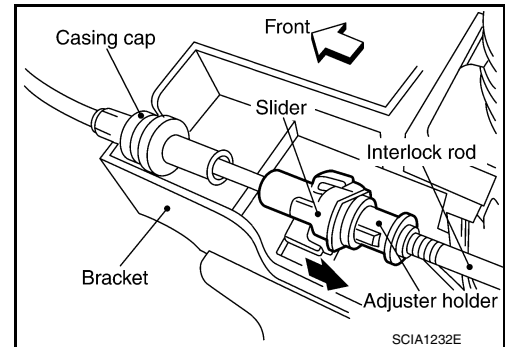

### INSTALLATION (Column shift models)

1. Install key interlock cable to ignition key cylinder.
2. Connect the shift lock cable.
3. Install knee protector.
4. Install instrument lower panel (LH). Refer to [IP-17, "Removal and Installation"](#).

# AIR BREATHER HOSE

< REMOVAL AND INSTALLATION >

## AIR BREATHER HOSE

2WD

2WD : Removal and Installation

INFOID:000000009885916

### COMPONENTS

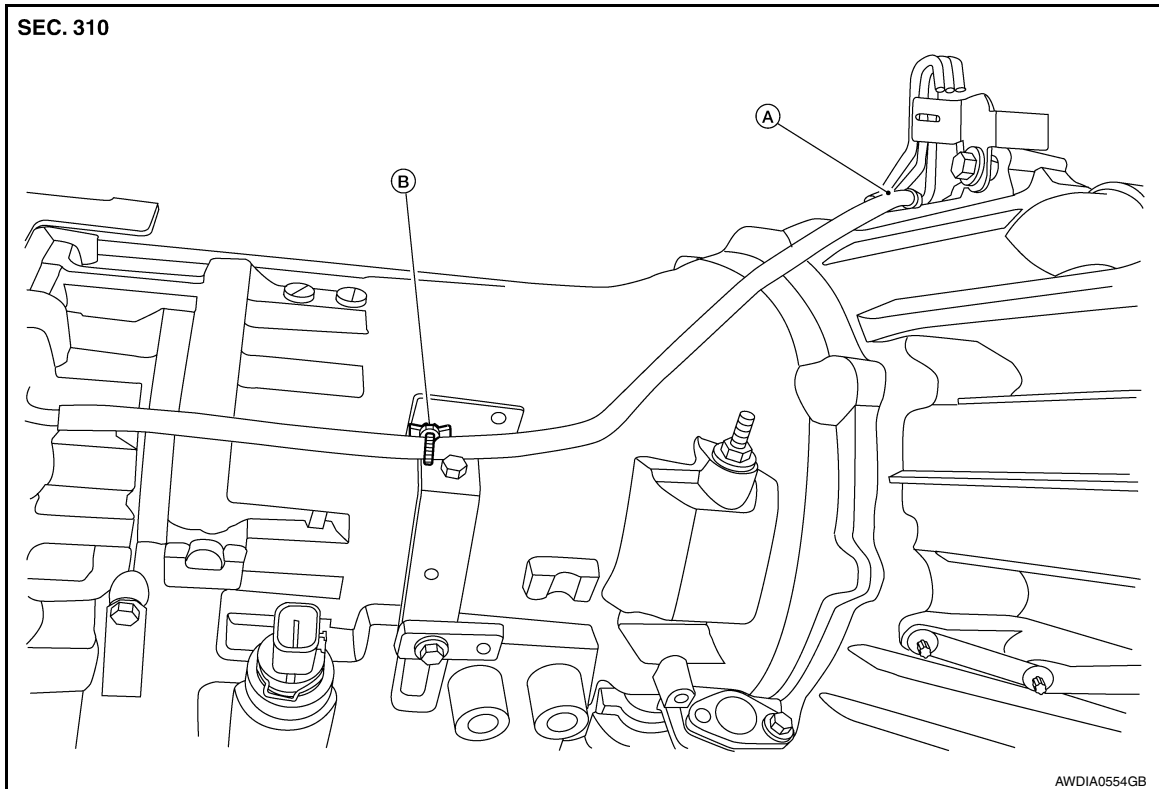

- A. Set air breather hose with paint mark at upper side
- B. Clip (set securely to bracket)

### REMOVAL

1. Release air breather hose from clip.
2. Disconnect air breather hose from transmission tube.
3. Disconnect air breather hose from air breather tube.

### INSTALLATION

Installation is in the reverse order of removal.

#### **CAUTION:**

- Install air breather hose with paint mark at upper side.
- When installing the air breather hose, do not crush or block by folding or bending the hose.
- When inserting the hose to the transmission tube, be sure to insert it fully until its end reaches the tube bend portion.
- Make sure clip is securely installed to bracket.

4WD

4WD : Removal and Installation

INFOID:000000009885917

### COMPONENTS

# AIR BREATHER HOSE

## < REMOVAL AND INSTALLATION >

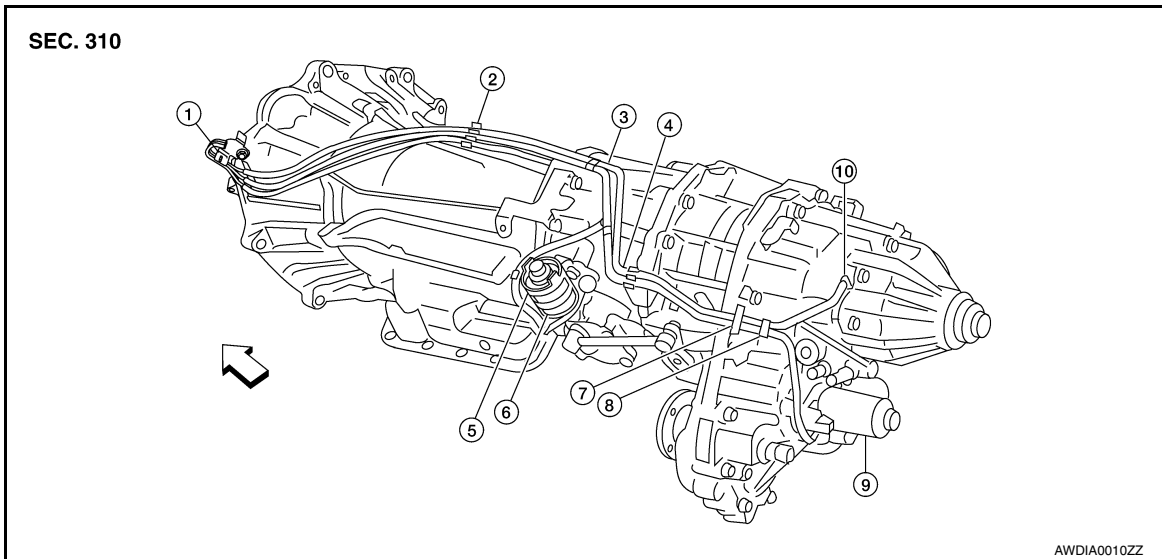

- |                              |           |                   |
|------------------------------|-----------|-------------------|
| 1. Breather tube             | 2. Clip A | 3. Clip B         |
| 4. Clip C                    | 5. Clip D | 6. Actuator       |
| 7. Air breather hose clamp   | 8. Clip E | 9. Transfer motor |
| 10. Breather tube (transfer) | ⇒ Front   |                   |

### REMOVAL

1. Disconnect air breather hose from transfer motor.
2. Disconnect air breather hose from breather tube (transfer).
3. Disconnect air breather hose from actuator.
4. Release air breather hose clamp and clips as necessary.
5. Disconnect air breather hoses from breather tube.

#### **CAUTION:**

**Note paint marks for installation.**

### INSTALLATION

#### **CAUTION:**

**Make sure there are no pinched or restricted areas on each air breather hose caused by folding or bending when installing it.**

1. Install each air breather hose into the breather tube (4). Set each air breather hose with paint mark facing upward.
  - A/T breather hose (1)
  - Transfer breather hose (2)
  - Actuator/transfer motor breather hose (3)
  - Paint marks (A)

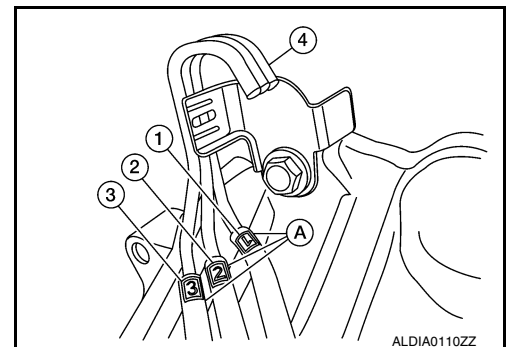

# AIR BREATHER HOSE

## < REMOVAL AND INSTALLATION >

2. Install actuator/transfer motor air breather hose (1) and transfer air breather hose (2) on clip (A) with the paint mark (B) facing upward.

• ⇐ :Front

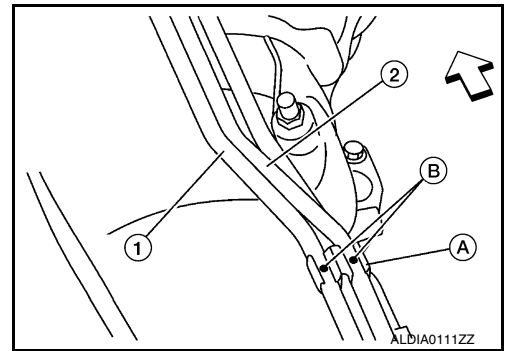

3. Install clip (B) on actuator/transfer motor air breather hose (1) and transfer air breather hose (2) with the paint mark (A) matched.

• ⇐ :Front

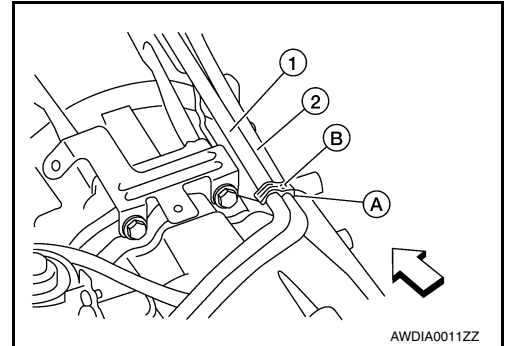

4. Install actuator/transfer motor air breather hose (1) and transfer air breather hose (2) on clip (B) and clip (C) with the paint mark (A) and (D) facing upward.

• ⇐ :Front

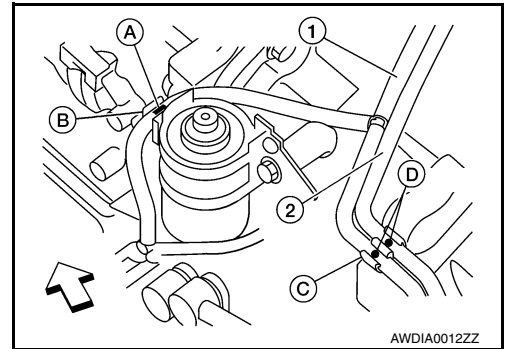

5. Install the actuator air breather hose into the actuator (case connector) until the hose end reaches the base of the tube. Set actuator air breather hose with paint mark facing leftward.

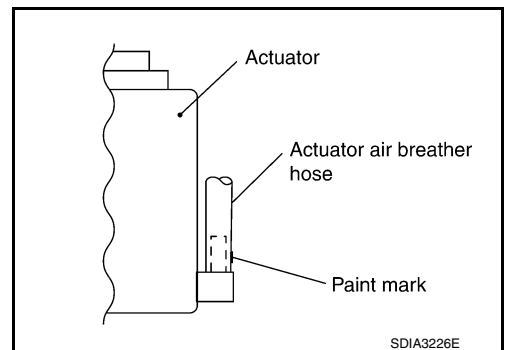

6. Install clip (B) on transfer motor air breather hose (2) and transfer air breather hose (1) with the paint mark (A) matched.

• ⇐ :Front

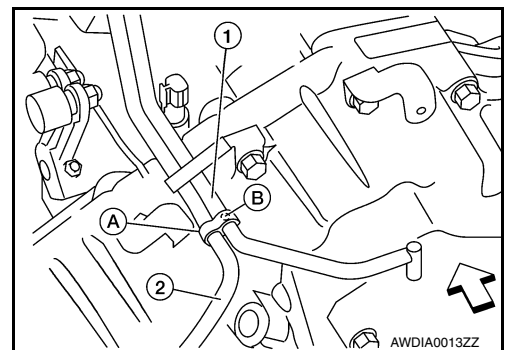

A  
B  
C  
TM  
E  
F  
G  
H  
I  
J  
K  
L  
M  
N  
O  
P

## AIR BREATHER HOSE

### < REMOVAL AND INSTALLATION >

7. Install the transfer air breather hose into the breather tube (transfer, metal connector) until the hose end reaches the base of the tube. Set transfer air breather hose with paint mark facing upwards.

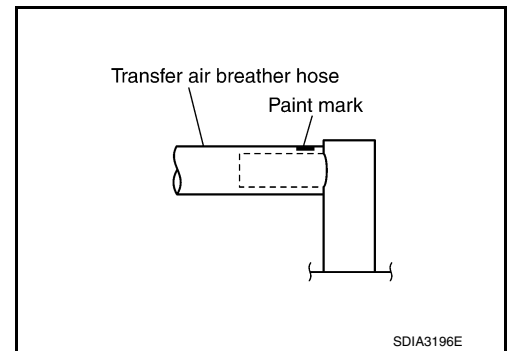

8. Install the transfer motor air breather hose into the transfer motor (case connector) until the hose end reaches the end of the curved section. Set transfer motor air breather hose with paint mark facing leftward.

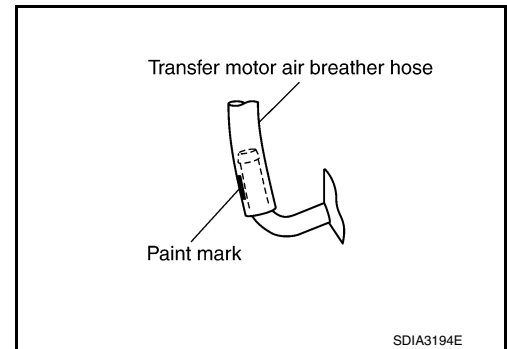

# OIL PAN

< REMOVAL AND INSTALLATION >

## OIL PAN

### Removal and Installation

INFOID:00000009885918

#### REMOVAL

1. Drain A/T fluid. Refer to [TM-174, "Changing the A/T Fluid \(ATF\)"](#).
2. Remove oil pan (2).
  - a. Remove oil pan clips (1).
    - ⇨ : Front
    - ➡ : Oil pan bolts
    - ● : Drain plug (3)
3. Remove oil pan gasket.

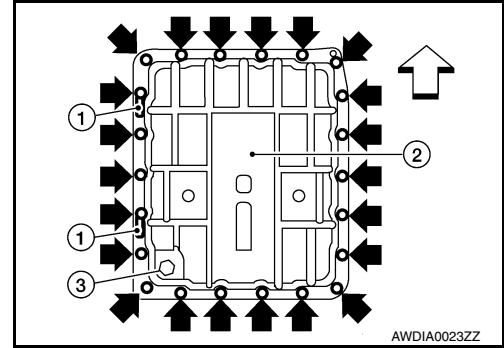

4. Check for foreign materials in oil pan to help determine cause of malfunction. If the A/T fluid is very dark, has some burned smell, or contains foreign particles then friction material (clutches, band) may need replacement. A tacky film that will not wipe clean indicates varnish build up. Varnish can cause valves, servo, and clutches to stick and can inhibit pump pressure.

#### **CAUTION:**

**If friction material is detected, flush the transmission cooler after repair. Refer to [TM-176, "A/T Fluid Cooler Cleaning"](#).**

5. Remove magnets from oil pan.

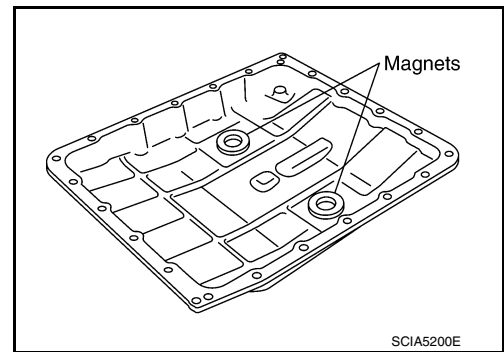

#### INSTALLATION

1. Install the oil pan magnets as shown.

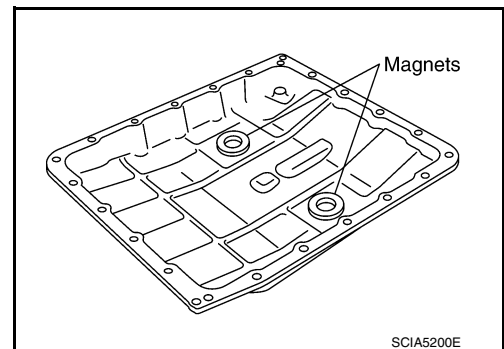

A  
B  
C  
TM  
E  
F  
G  
H  
I  
J  
K  
L  
M  
N  
O  
P

# OIL PAN

## < REMOVAL AND INSTALLATION >

2. Install the oil pan (2) with a new oil pan gasket.

- ⇨ : Front
- ➡ : Oil pan bolts
- ① : Clips (1)
- ③ : Drain plug (3)

**CAUTION:**

- Be sure the oil drain plug is located to the rear of the transmission assembly.
- Before installing oil pan bolts, remove any traces of old sealant from the sealing surfaces and threaded holes.
- Do not reuse old gasket, replace with a new one.
- Always replace the oil pan bolts as they are self-sealing.
- Partially install the oil pan bolts in a criss-cross pattern to prevent dislocation of the gasket.

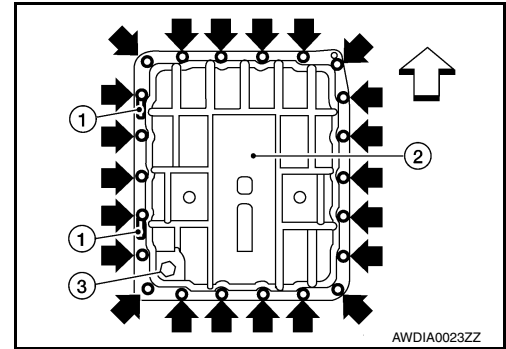

3. Install oil pan bolts and clips tighten in numerical order as shown.

**Oil pan bolts : 7.9 N·m (0.81 kg-m, 70 in-lb)**

4. Install drain plug with new gasket to oil pan and tighten to specification.

**Drain plug : 34 N·m (3.5 kg-m, 25 ft-lb)**

**CAUTION:**

**Do not reuse drain plug gasket.**

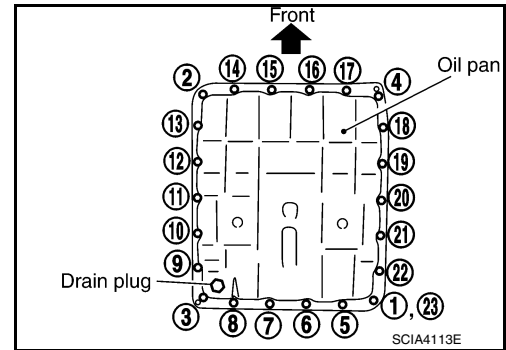

5. Refill the A/T with fluid and check for fluid leakage. Refer to [TM-172. "Checking the A/T Fluid \(ATF\)".](#)



# CONTROL VALVE WITH TCM

< REMOVAL AND INSTALLATION >

## CONTROL VALVE WITH TCM

### Control Valve with TCM

INFOID:00000009885919

#### COMPONENTS

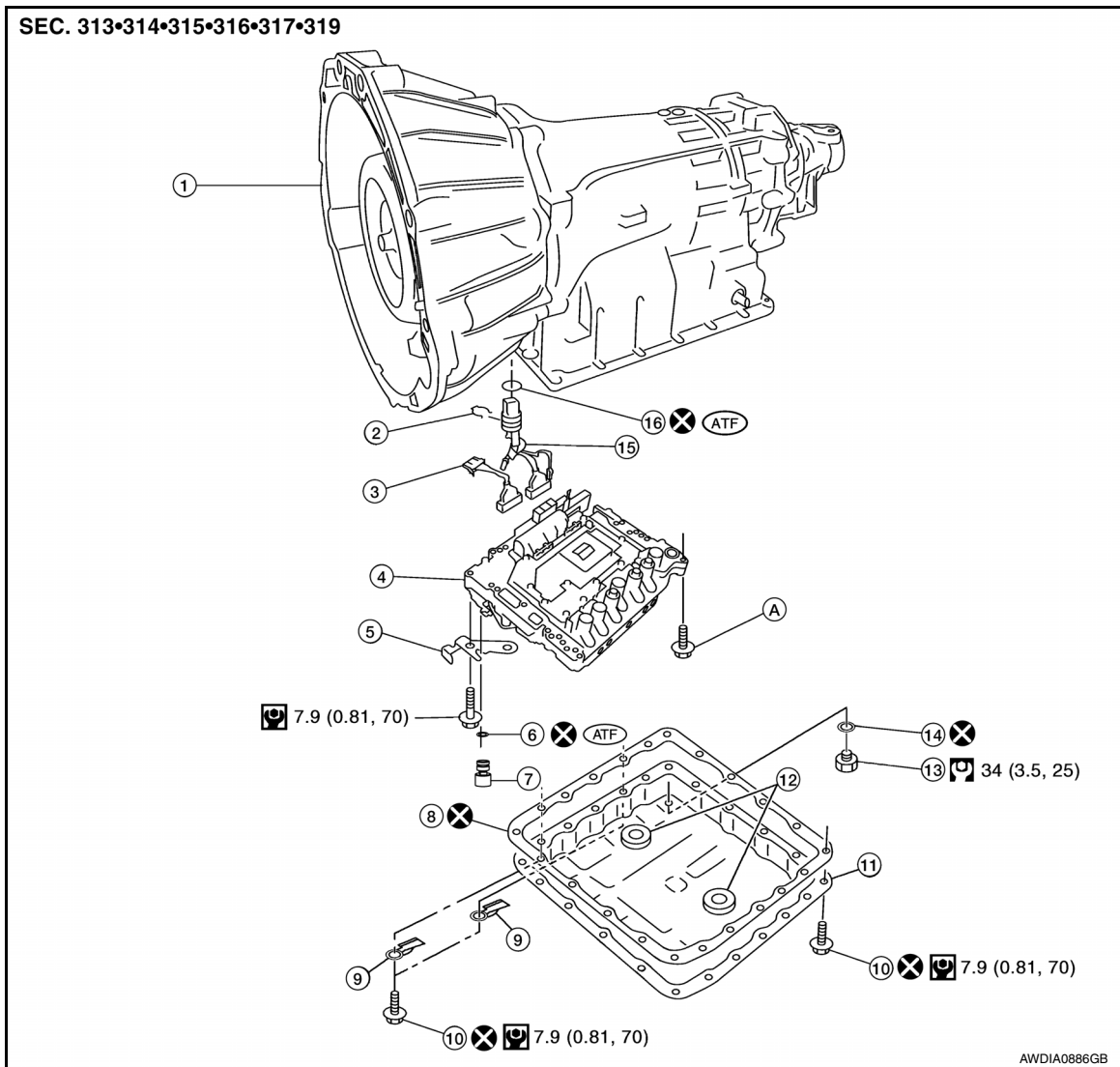

- |                           |   |                            |
|---------------------------|---|----------------------------|
| 1. Transmission           | 2. Snap ring                                      | 3. Sub-harness             |
| 4. Control valve with TCM | 5. Bracket  | 6. O-ring                  |
| 7. Plug                   | 8. Oil pan gasket                                 | 9. Brackets                |
| 10. Oil pan bolt          | 11. Oil pan                                       | 12. Magnet                 |
| 13. Drain plug            | 14. Drain plug gasket                             | 15. Terminal cord assembly |
| 16. O-ring                | A. For tightening torque, refer to "Installation" |                            |

#### REMOVAL AND INSTALLATION OF CONTROL VALVE WITH TCM

##### Removal

1. Disconnect negative battery terminal.
2. Drain A/T fluid. Refer to [TM-174. "Changing the A/T Fluid \(ATF\)".](#)
3. Disconnect A/T assembly harness connector.

# CONTROL VALVE WITH TCM

## < REMOVAL AND INSTALLATION >

4. Remove snap ring from A/T assembly harness connector.

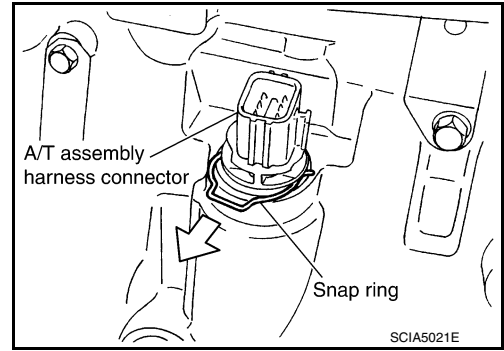

5. Push A/T assembly harness connector.

**CAUTION:**  
Do not damage connector.

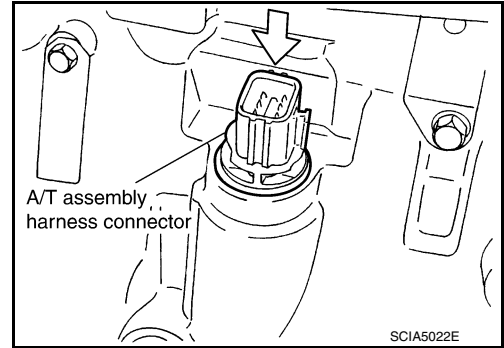

6. Remove oil pan and oil pan gasket. Refer to [TM-199, "Removal and Installation"](#).

7. Straighten terminal clip (←) to free the output speed sensor harness.

8. Disconnect output speed sensor connector (1).

**CAUTION:**  
Do not damage connector.

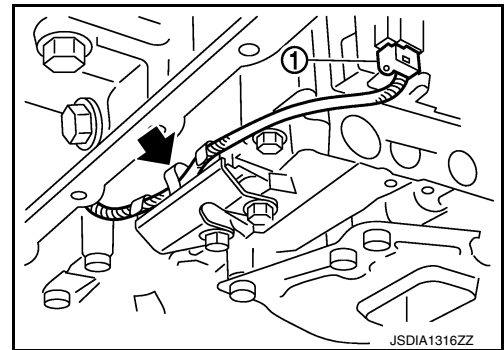

9. Remove bolts (A), (B) and (C) from control valve with TCM.

← : Front

Bolt symbol	Length mm (in)	Number of bolts
A	42 (1.65)	5
B	55 (2.17)	6
C	40 (1.57)	1

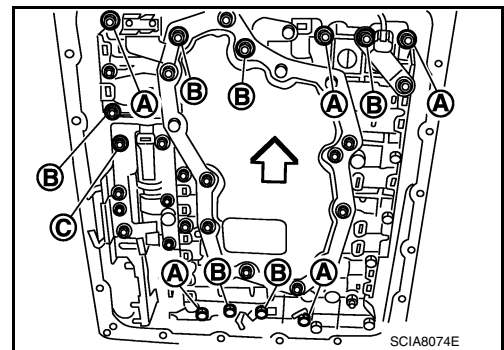

# CONTROL VALVE WITH TCM

## < REMOVAL AND INSTALLATION >

10. Remove control valve with TCM from transmission case.

**CAUTION:**

When removing, be careful with the manual valve notch and manual plate height. Remove it vertically.

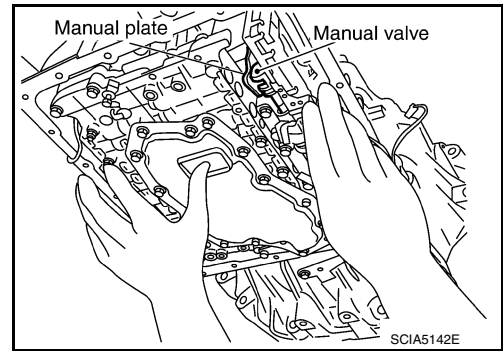

11. Remove plug (1) with bracket (2) from control valve with TCM.

-  :Bolt

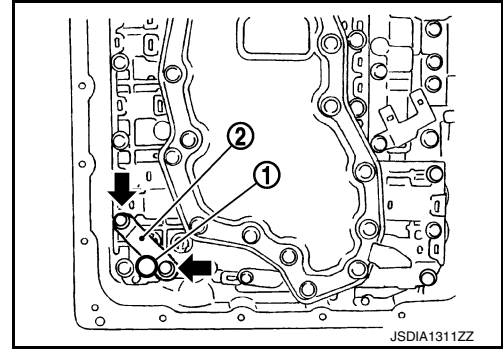

12. Remove the bracket (1) from plug (2).

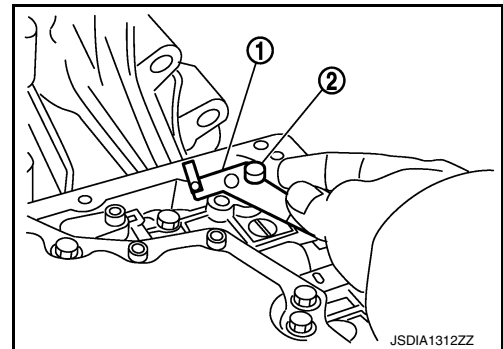

13. Remove O-ring (1) from plug (2).

**CAUTION:**

Do not reuse O-ring.

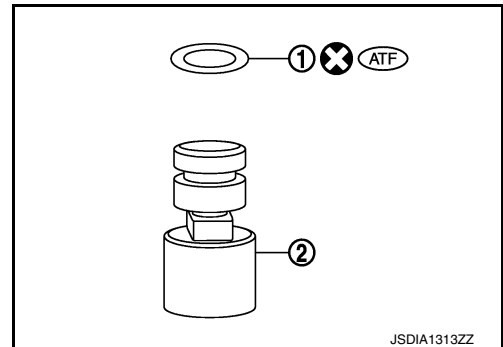

A  
B  
C  
TM  
E  
F  
G  
H  
I  
J  
K  
L  
M  
N  
O  
P

## CONTROL VALVE WITH TCM

### < REMOVAL AND INSTALLATION >

14. Remove O-ring from A/T assembly harness connector.

**CAUTION:**  
Do not reuse O-ring.

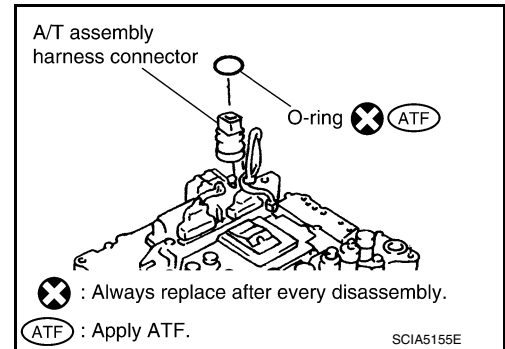

15. Disconnect TCM connectors.

**CAUTION:**  
Do not damage connectors.

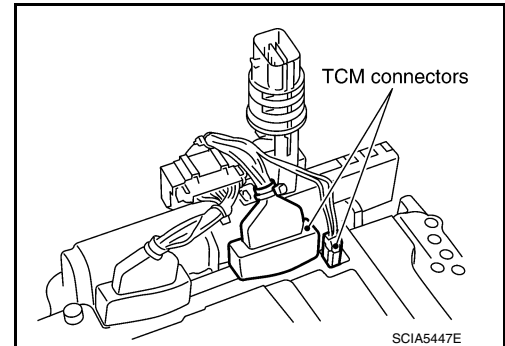

16. Remove A/T assembly harness connector from control valve with TCM using suitable tool.

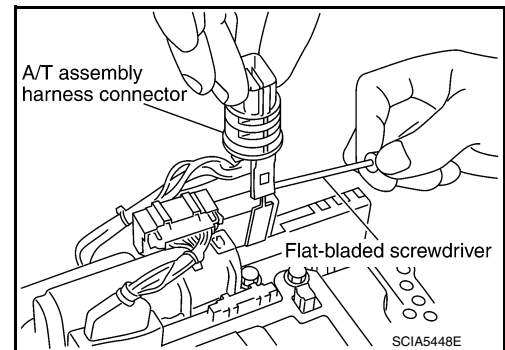

17. Disconnect TCM connector (1) and transmission range switch connector (2).

**CAUTION:**  
Do not damage connectors.

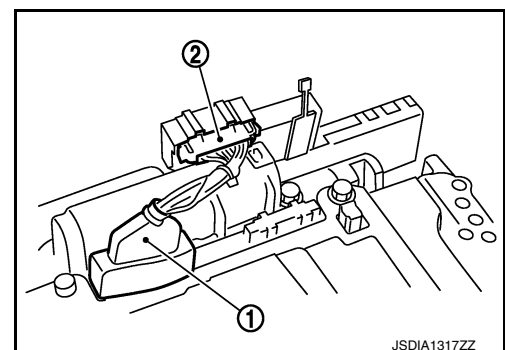

### Installation

**CAUTION:**  
After completing installation, check A/T fluid leakage and fluid level. Refer to [TM-172, "Checking the A/T Fluid \(ATF\)"](#).

# CONTROL VALVE WITH TCM

## < REMOVAL AND INSTALLATION >

1. Connect TCM connector (1) and transmission range switch connector (2).

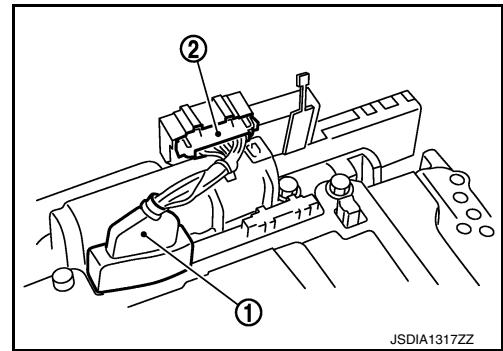

2. Install A/T assembly harness connector to control valve with TCM.

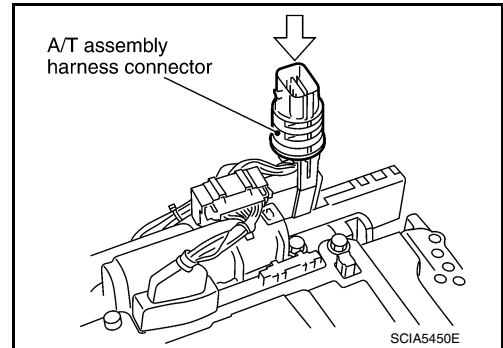

3. Connect TCM connector.

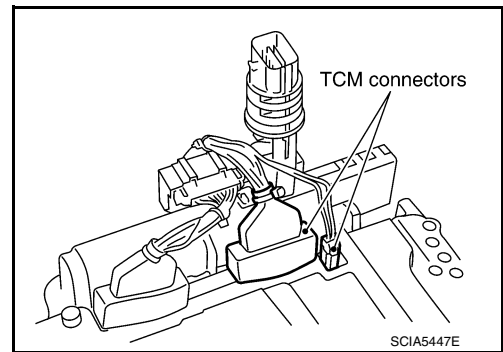

4. Install new O-ring in A/T assembly harness connector.

**CAUTION:**

- Do not reuse O-ring.
- Apply ATF to O-ring.

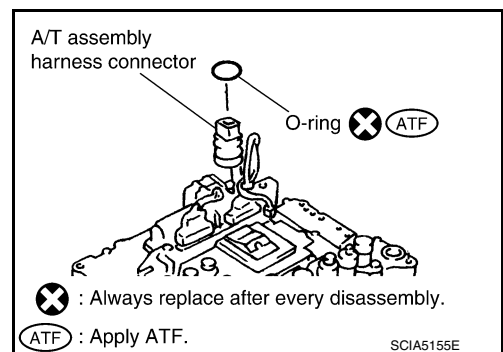

5. Install new O-ring (1) in plug (2).

**CAUTION:**

- Do not reuse O-ring.
- Apply ATF to O-ring.
- O-ring should be free of contamination.

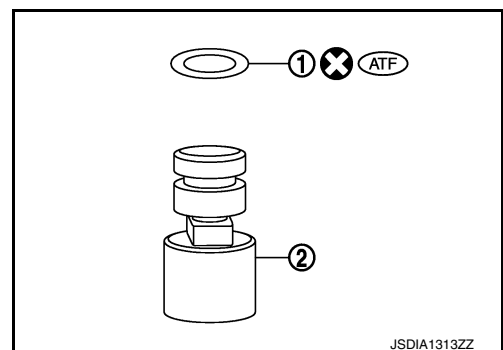

A  
B  
C  
TM  
E  
F  
G  
H  
I  
J  
K  
L  
M  
N  
O  
P

# CONTROL VALVE WITH TCM

## < REMOVAL AND INSTALLATION >

6. Install plug (2) to bracket(1).

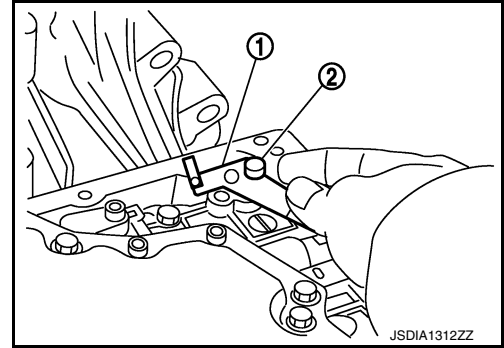

7. Install plug (1) [with bracket (2)] to control valve with TCM.

• ← :Bolt

**CAUTION:**

**Adjust bolt hole of bracket to bolt hole of control valve with TCM.**

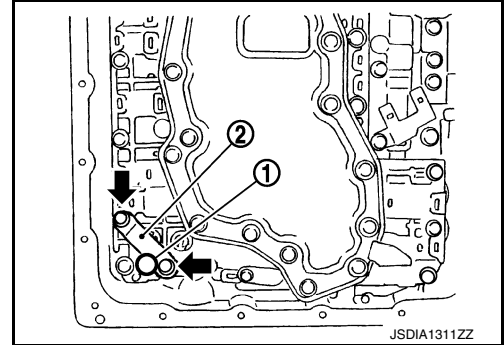

8. Install control valve with TCM in transmission case.

(1) : Brake band

**CAUTION:**

- Make sure that input speed sensor is securely installed into input speed sensor hole (A).
- Hang down output speed sensor harness toward outside so as not to disturb installation of control valve with TCM.
- Adjust A/T assembly harness connector of control valve with TCM to terminal hole of transmission case.

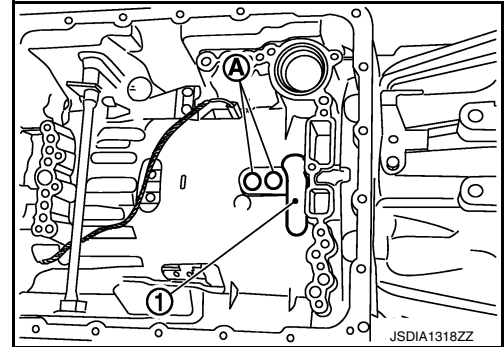

- Assemble it so that manual valve cutout is engaged with manual plate projection.

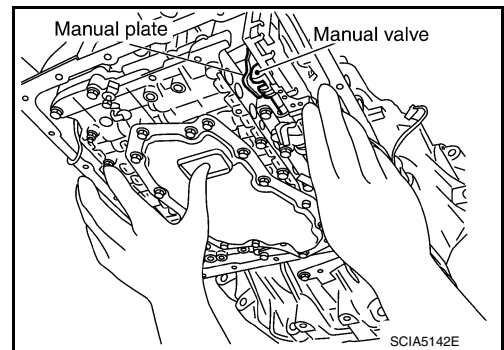

9. Install bolts (A), (B) and (C) in control valve with TCM.

← : Front

Bolt symbol	Length mm (in)	Number of bolts
A	42 (1.65)	5
B	55 (2.17)	6
C	40 (1.57)	1

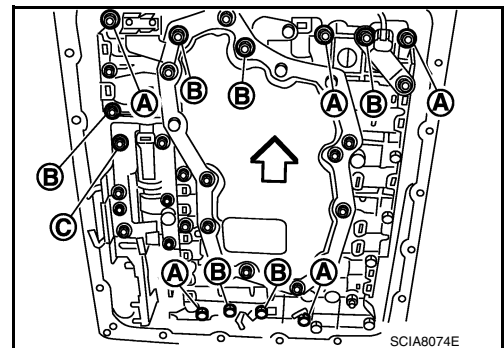

# CONTROL VALVE WITH TCM

## < REMOVAL AND INSTALLATION >

10. Tighten bolt (1A), (2B) and (3A) temporarily to prevent dislocation. After that tighten them in order (1 → 2 → 3). Then tighten other bolts.

← : Front

11. Tighten control valve with TCM bolts to the specified torque.

Bolt symbol	A	B	C
Number of bolts	5	6	1
Length mm (in)	42 (1.65)	55 (2.17)	40 (1.57)
Tightening torque N·m (kg-m, in-lb)	7.9 (0.81, 70)		With ATF applied 7.9 (0.81, 70)

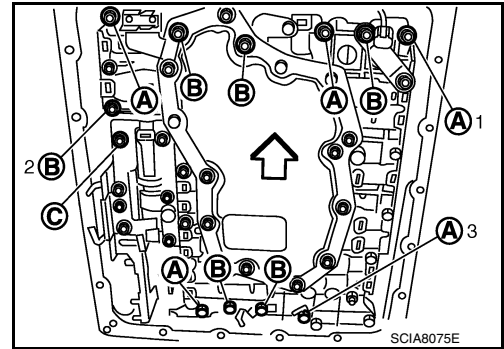

12. Connect output speed sensor connector (1).

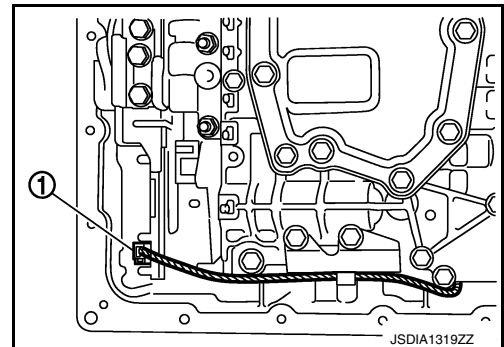

13. Securely fasten output speed sensor (1) harness with terminal clip (←).

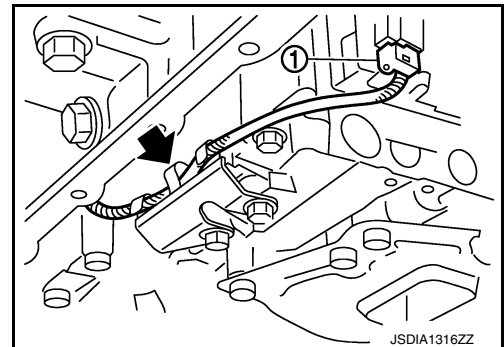

14. Install oil pan to transmission case. Refer to [TM-199, "Removal and Installation"](#).

15. Pull up A/T assembly harness connector.

**CAUTION:**

**Do not damage connector.**

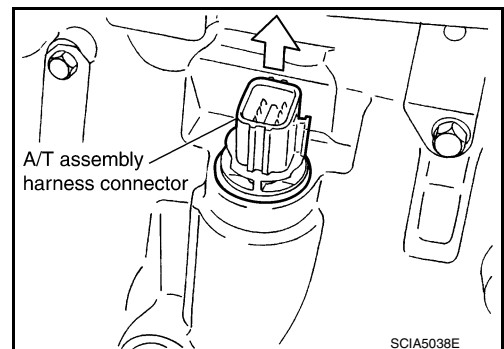

## CONTROL VALVE WITH TCM

### < REMOVAL AND INSTALLATION >

16. Install snap ring to A/T assembly harness connector.
17. Connect A/T assembly harness connector.
18. Connect the negative battery terminal.
19. Refill the A/T with fluid and check the fluid level and for fluid leakage. Refer to [TM-172, "Checking the A/T Fluid \(ATF\)"](#).

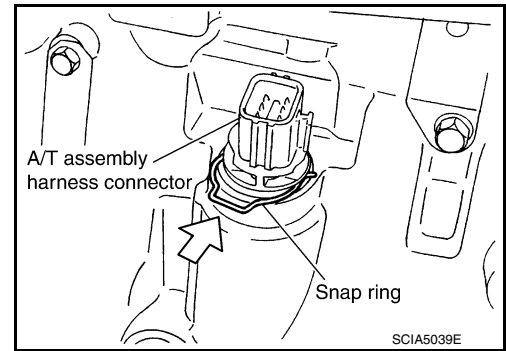



# REAR OIL SEAL

< REMOVAL AND INSTALLATION >

## REAR OIL SEAL

### Removal and Installation

INFOID:00000009885920

#### REMOVAL

1. Remove rear propeller shaft. Refer to [DLN-139, "Removal and Installation"](#).
2. Remove transfer from transmission (4WD models). Refer to [TM-213, "Removal and Installation \(4WD\)"](#).
3. Remove rear oil seal using suitable tool.

**CAUTION:**

**Do not scratch rear extension assembly (2WD models) or adapter case assembly (4WD models).**

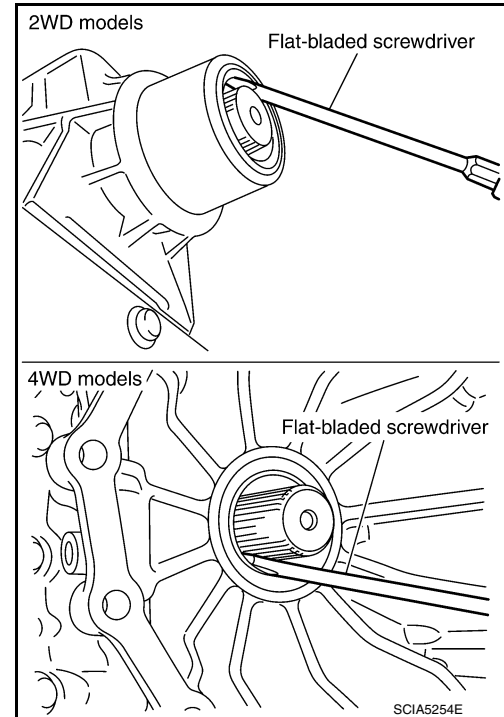

#### INSTALLATION

1. Install new rear oil seal until it is flush into the rear extension case (2WD models) using Tool or adapter case (4WD models) using suitable tool.

**Tool number : ST33400001 (J-26082)**

**CAUTION:**

- Apply ATF to rear oil seal.
- Do not reuse rear oil seal.

2. Install transfer to transmission (4WD models). Refer to [TM-213, "Removal and Installation \(4WD\)"](#).
3. Install rear propeller shaft. Refer to [DLN-139, "Removal and Installation"](#).
4. Check the A/T fluid level and for fluid leakage. Refer to [TM-172, "Checking the A/T Fluid \(ATF\)"](#).

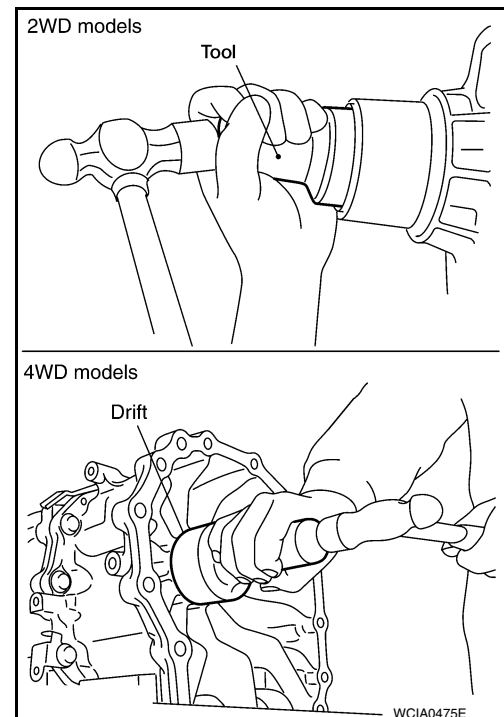

A  
B  
C  
TM  
E  
F  
G  
H  
I  
J  
K  
L  
M  
N  
O  
P

# FLUID COOLER SYSTEM

< REMOVAL AND INSTALLATION >

## FLUID COOLER SYSTEM

Exploded View

INFOID:000000009885921

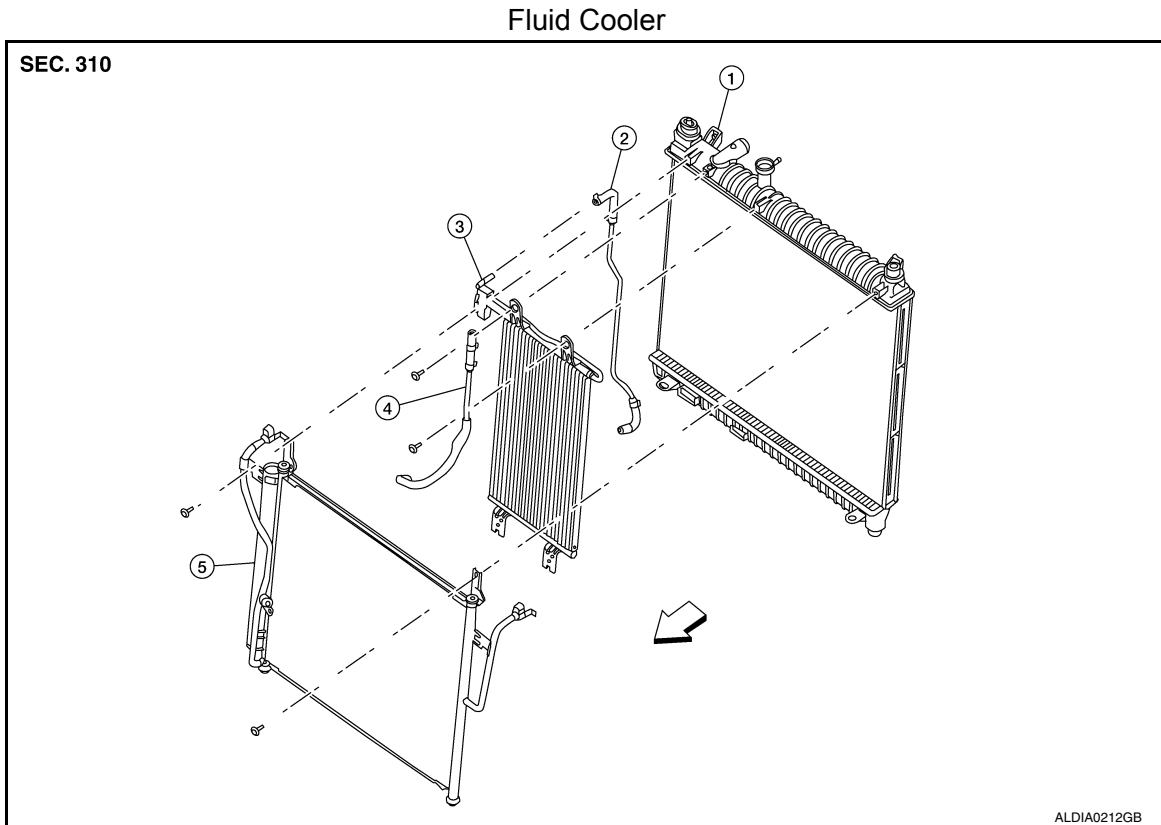

- |                      |                      |                 |
|----------------------|----------------------|-----------------|
| 1. Radiator          | 2. Fluid cooler hose | 3. Fluid cooler |
| 4. Fluid cooler hose | 5. A/C condenser     | ← Front         |

## Removal and Installation

INFOID:000000009885922

### REMOVAL

1. Remove the radiator. Refer to [CO-15. "Removal and Installation"](#).
2. Disconnect the transmission fluid cooler hoses.
3. Remove the transmission fluid cooler.

### INSTALLATION

Installation is in the reverse order of removal.

# TRANSMISSION ASSEMBLY

< UNIT REMOVAL AND INSTALLATION >

## UNIT REMOVAL AND INSTALLATION

### TRANSMISSION ASSEMBLY

Removal and Installation (2WD)

INFOID:000000009885923

#### COMPONENTS

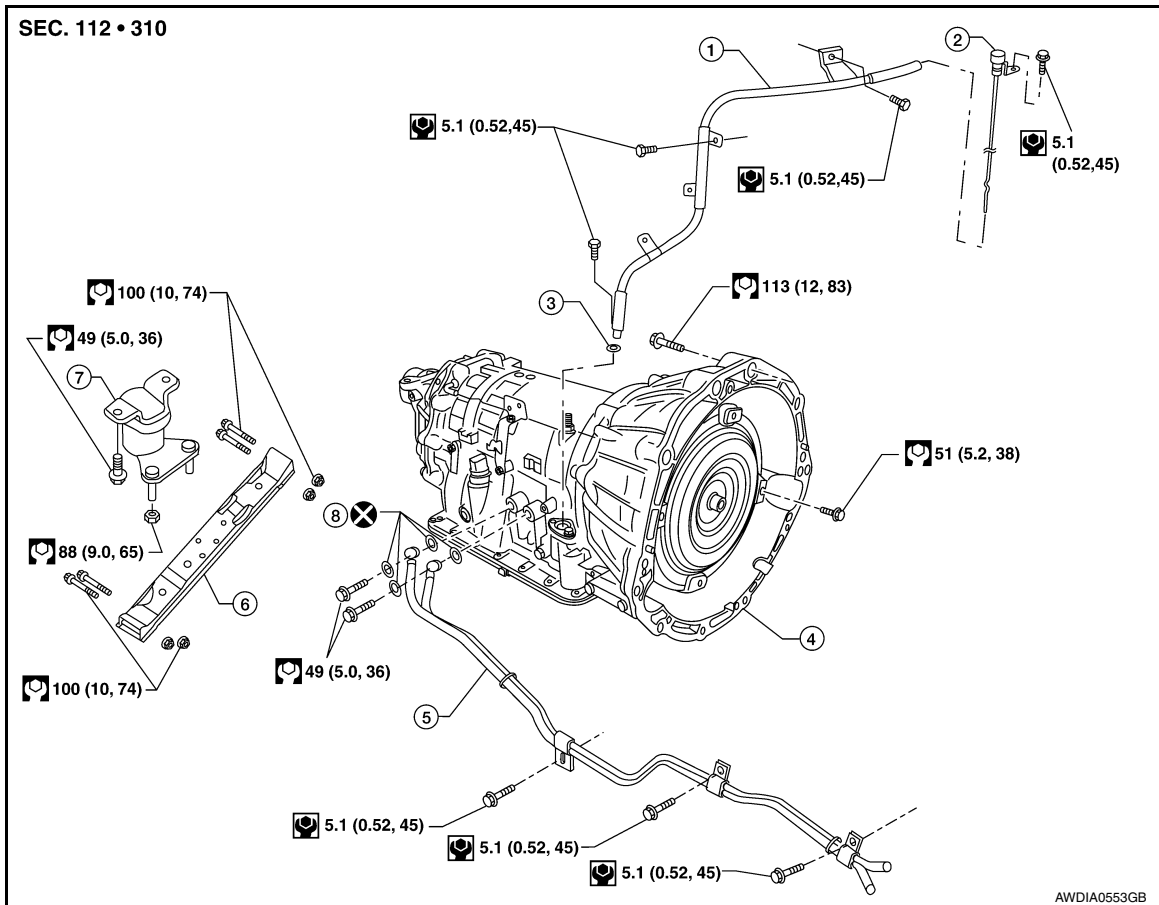

- |                             |                           |                     |
|-----------------------------|---------------------------|---------------------|
| 1. A/T fluid indicator pipe | 2. A/T fluid indicator    | 3. O-ring           |
| 4. Transmission assembly    | 5. Fluid cooler tube      | 6. A/T cross member |
| 7. Insulator                | 8. Copper sealing washers |                     |

#### CAUTION:

- Before replacing transmission assembly, perform "ADDITIONAL SERVICE WHEN REPLACING TRANSMISSION ASSEMBLY". Refer to [TM-9, "ADDITIONAL SERVICE WHEN REPLACING TRANSMISSION ASSEMBLY : Special Repair Requirement"](#).
- When removing the A/T assembly from engine, first remove the crankshaft position sensor (POS) from the A/T assembly. Be careful not to damage sensor edge.

#### NOTE:

When removing components such as hoses, tubes/lines, etc., cap or plug openings to prevent fluid from spilling.

#### REMOVAL

1. Disconnect the battery negative terminal. Refer to [PG-80, "Removal and Installation"](#).
2. Remove A/T fluid indicator.
3. Remove engine under cover using power tool. Refer to [EXT-15, "Removal and Installation"](#).

# TRANSMISSION ASSEMBLY

## < UNIT REMOVAL AND INSTALLATION >

4. Remove crankshaft position sensor (POS) from A/T assembly.

**CAUTION:**

- Do not subject it to impact by dropping or hitting it.
- Do not disassemble.
- Do not allow metal filings or foreign material to get on the sensor front edge magnetic area.
- Do not place in an area affected by magnetism.

5. Remove A/T fluid indicator pipe.

**CAUTION:**

**Do not reuse O-ring.**

6. Remove exhaust front tube and center muffler using power tool.

Refer to [EX-5, "Removal and Installation"](#).

7. Remove rear propeller shaft. Refer to [DLN-148, "Removal and Installation"](#).

8. Disconnect control cable.

9. Remove A/T fluid cooler tubes from A/T assembly.

**CAUTION:**

**Do not reuse copper sealing washers.**

10. Support A/T assembly with a transmission jack.

**CAUTION:**

**When setting the transmission jack, be careful not to allow it to collide against the drain plug.**

11. Remove dust cover from converter housing.

12. Turn crankshaft to access and remove the four bolts for drive plate and torque converter.

**CAUTION:**

**When turning crankshaft, turn it clockwise as viewed from the front of the engine.**

13. Remove cross member using power tool.

14. Remove air breather hose. Refer to [TM-195, "2WD : Removal and Installation"](#).

15. Disconnect A/T assembly harness connector.

16. Remove the A/T assembly to engine bolts using power tool.

17. Remove A/T assembly from vehicle using transmission jack.

**CAUTION:**

- Secure torque converter to prevent it from dropping.
- Secure A/T assembly to a transmission jack.

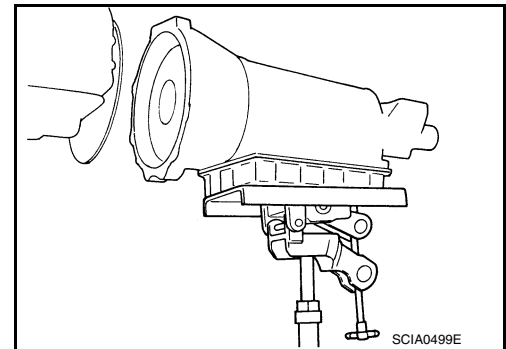
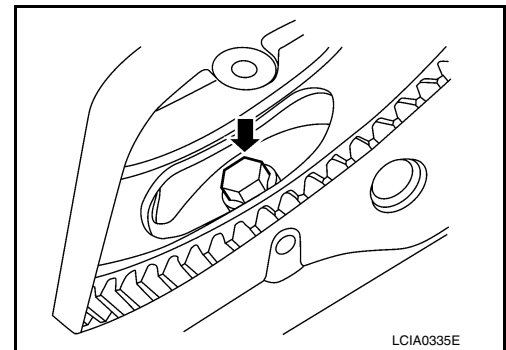
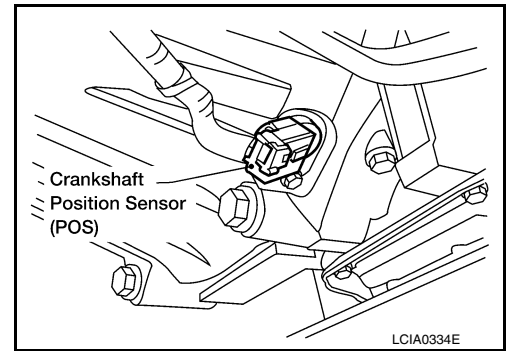

## INSPECTION

### Installation and Inspection of Torque Converter

- After inserting a torque converter to a transmission, be sure to check distance (A) to ensure it is within specifications.

**Distance (A) : 24.0 mm (0.94 in) or more**

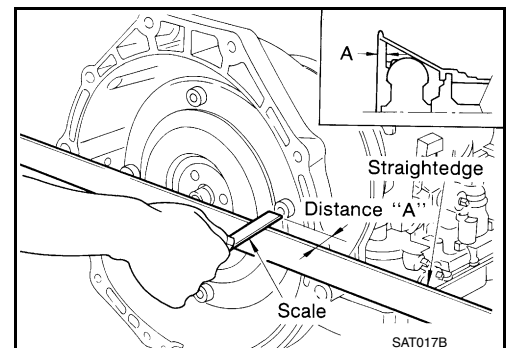

# TRANSMISSION ASSEMBLY

## < UNIT REMOVAL AND INSTALLATION >

### INSTALLATION

Installation is in the reverse order of removal, while paying attention to the following:

#### CAUTION:

**Do not reuse O-ring and copper sealing washers.**

- When installing transmission to the engine, attach the bolts in the order as shown.

**Transmission to engine bolts : 113 N·m (12 kg-m, 83 ft-lb)**

#### CAUTION:

- **When replacing an engine or transmission you must make sure the dowels are installed correctly during re-assembly.**
- **Improper alignment caused by missing dowels may cause vibration, oil leaks or breakage of drivetrain components.**

#### NOTE:

- \*: No.2 bolt also secures air breather tube.
- Align the positions of bolts for drive plate with those of the torque converter, and temporarily tighten the bolts. Then tighten the bolts with the specified torque. Refer to [TM-211, "Removal and Installation \(2WD\)"](#).

#### CAUTION:

- **When turning crankshaft, turn it clockwise as viewed from the front of the engine.**
- **After converter is installed to drive plate, rotate crankshaft several turns and check to be sure that transmission rotates freely without binding.**
- Install crankshaft position sensor (POS).
- After completing installation check fluid leakage, fluid level and the positions of A/T. Refer to [TM-172, "Checking the A/T Fluid \(ATF\)"](#) and [TM-190, "Inspection and Adjustment"](#).

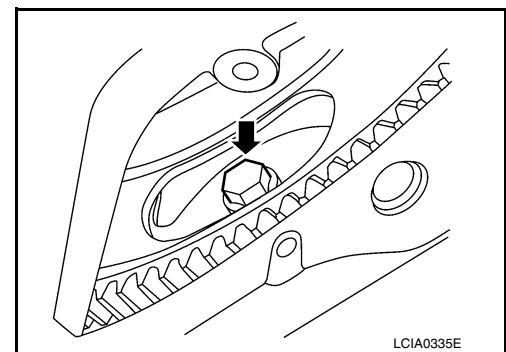
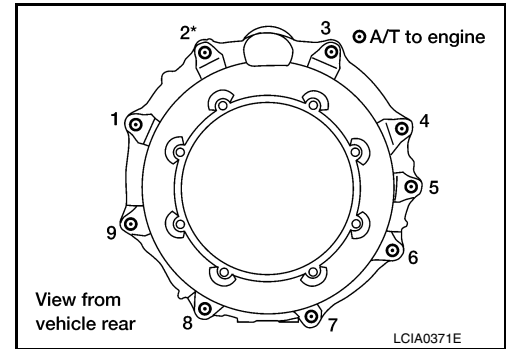

### Removal and Installation (4WD)

INFOID:000000009885924

### COMPONENTS

# TRANSMISSION ASSEMBLY

< UNIT REMOVAL AND INSTALLATION >

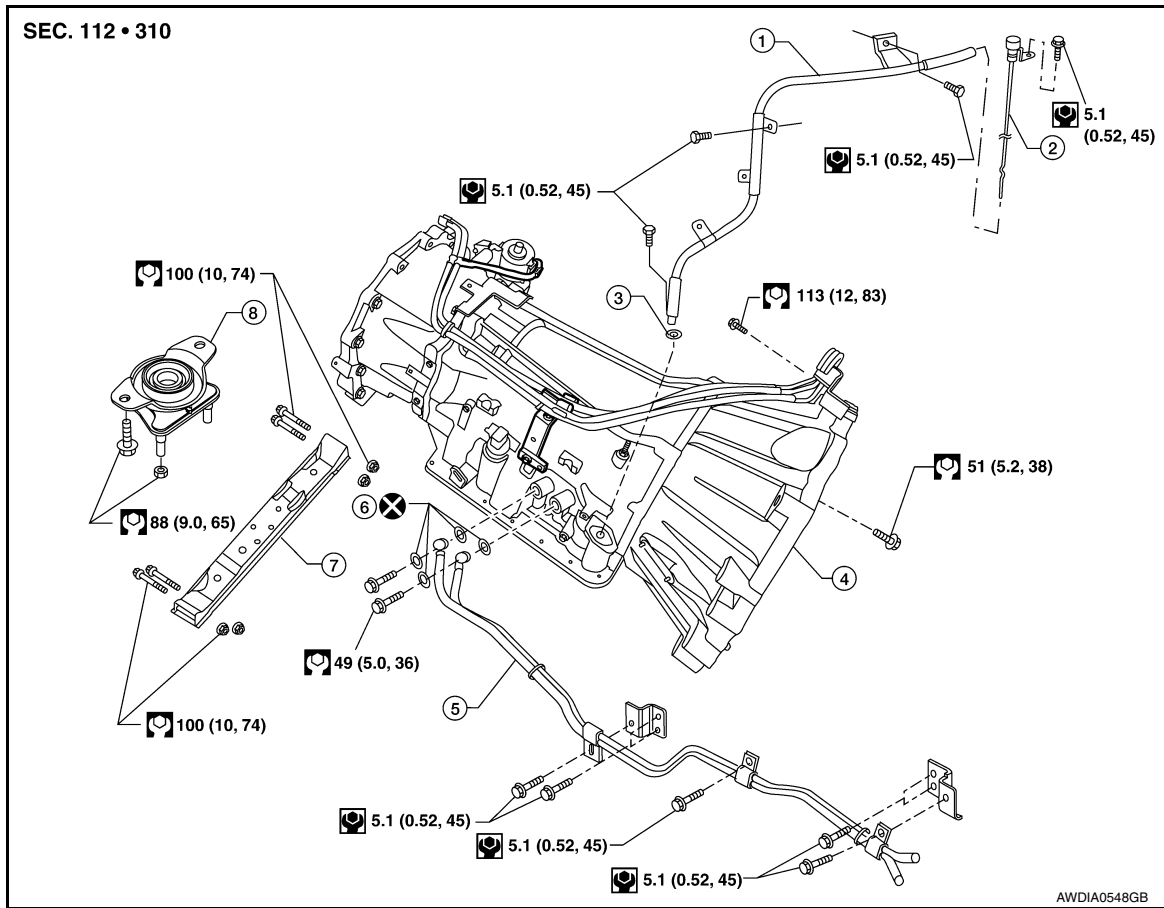

- |                             |                        |                          |
|-----------------------------|------------------------|--------------------------|
| 1. A/T fluid indicator pipe | 2. A/T fluid indicator | 3. O-ring                |
| 4. Transmission assembly    | 5. Fluid cooler tube   | 6. Copper sealing washer |
| 7. A/T cross member         | 8. Insulator           |                          |

## CAUTION:

- Before replacing transmission assembly, perform "ADDITIONAL SERVICE WHEN REPLACING TRANSMISSION ASSEMBLY". Refer to [TM-9, "ADDITIONAL SERVICE WHEN REPLACING TRANSMISSION ASSEMBLY : Special Repair Requirement"](#).
- When removing the A/T assembly from engine, first remove the crankshaft position sensor (POS) from the A/T assembly. Be careful not to damage sensor edge.

## NOTE:

When removing components such as hoses, tubes/lines, etc., cap or plug openings to prevent fluid from spilling.

## REMOVAL

1. Disconnect the battery negative terminal. Refer to [PG-80, "Removal and Installation"](#).
2. Remove A/T fluid indicator.
3. Remove engine under cover using power tool. Refer to [EXT-15, "Removal and Installation"](#).
4. Remove transfer under cover using power tool (if equipped).
5. Remove exhaust front tube and center muffler using power tool. Refer to [EX-5, "Removal and Installation"](#).
6. Remove propeller shafts. Refer to [DLN-130, "Removal and Installation"](#) (2F1310) or [DLN-148, "Removal and Installation"](#) (3S1410).
7. Disconnect control cable.

# TRANSMISSION ASSEMBLY

## < UNIT REMOVAL AND INSTALLATION >

8. Remove crankshaft position sensor (POS) from A/T assembly.

**CAUTION:**

- Do not subject it to impact by dropping or hitting it.
- Do not disassemble.
- Do not allow metal filings or foreign material to get on the sensor front edge magnetic area.
- Do not place in an area affected by magnetism.

9. Remove A/T fluid cooler tubes from A/T assembly.

**CAUTION:**

**Do not reuse copper sealing washers.**

10. Remove dust cover from converter housing.

11. Turn crankshaft to access and remove the four bolts for drive plate and torque converter.

**CAUTION:**

**When turning crankshaft, turn it clockwise as viewed from the front of the engine.**

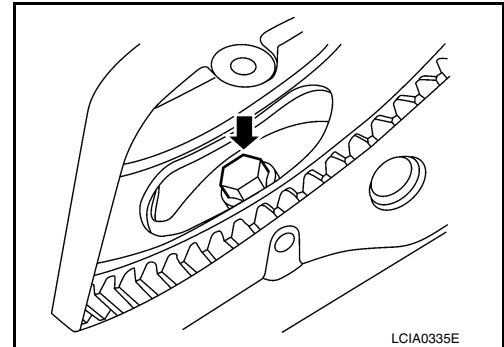
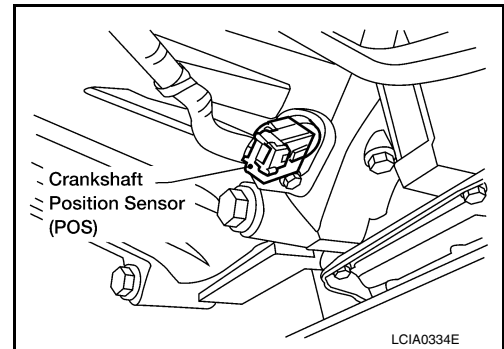

12. Support A/T assembly using transmission jack and Tool.

**Tool number : — (J-47002)**

**CAUTION:**

**When setting the transmission jack, be careful not to allow it to collide against the drain plug.**

13. Remove cross member using power tool.

14. Tilt the transmission slightly to keep the clearance between body and transmission, then disconnect air breather hose. Refer to [TM-195, "4WD : Removal and Installation"](#).

15. Remove air breather hose. Refer to [TM-195, "4WD : Removal and Installation"](#).

16. Disconnect the following.

- Neutral 4 low switch
- Wait detection switch
- Transfer motor connector
- A/T assembly connector
- Transfer control device connector
- ATP switch connector
- Transfer terminal cord assembly connector

17. Remove A/T fluid indicator pipe.

**CAUTION:**

**Do not reuse O-ring.**

18. Remove A/T assembly to engine bolts using power tool.

19. Remove A/T assembly with transfer from vehicle.

**CAUTION:**

- Secure torque converter to prevent it from dropping.
- Secure A/T assembly to transmission jack.

20. Remove transfer from A/T assembly. Refer to [DLN-100, "Removal and Installation"](#).

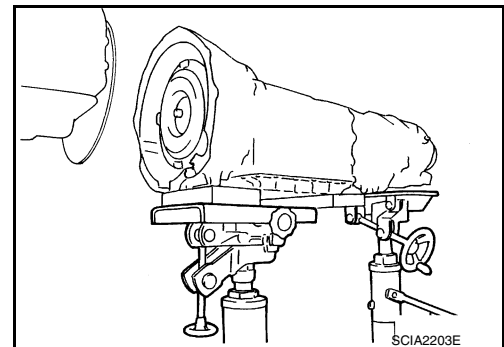

## INSPECTION

# TRANSMISSION ASSEMBLY

## < UNIT REMOVAL AND INSTALLATION >

### Installation and Inspection of Torque Converter

- After inserting a torque converter to a transmission, be sure to check distance (A) to ensure it is within specifications.

**Distance (A) : 24.0 mm (0.94 in) or more**

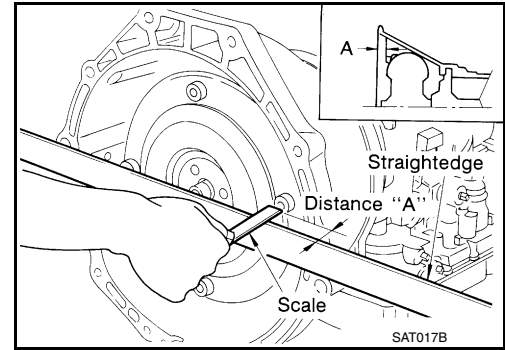

## INSTALLATION

Installation is in the reverse order of removal, while paying attention to the following:

### CAUTION:

**Do not reuse O-ring and copper sealing washers.**

- When installing transmission to the engine, attach the bolts as shown.

**Transmission to engine bolts : 113 N·m (12 kg·m, 83 ft·lb)**

### CAUTION:

- When replacing an engine or transmission you must make sure the dowels are installed correctly during re-assembly.
- Improper alignment caused by missing dowels may cause vibration, oil leaks or breakage of drivetrain components.

### NOTE:

\*: No.2 bolt also secures air breather tube.

- Align the positions of bolts for drive plate with those of the torque converter, and temporarily tighten the bolts. Then tighten the bolts with the specified torque. Refer to [TM-213, "Removal and Installation \(4WD\)"](#).

### CAUTION:

- When turning crankshaft, turn it clockwise as viewed from the front of the engine.
- After converter is installed to drive plate, rotate crankshaft several turns and check to be sure that transmission rotates freely without binding.
- Install crankshaft position sensor (POS).
- After completing installation, check fluid leakage, fluid level, and the positions of A/T. Refer to [TM-172, "Checking the A/T Fluid \(ATF\)"](#) and [TM-190, "Inspection and Adjustment"](#).

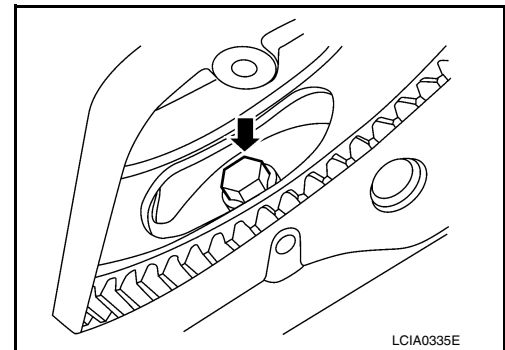
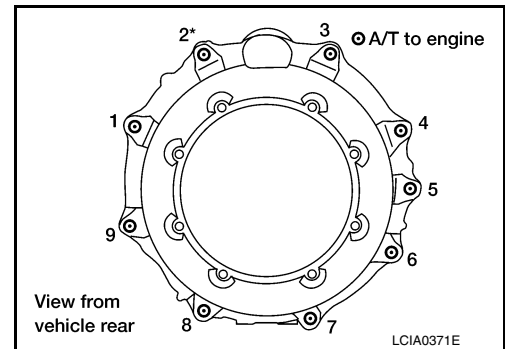



# OVERHAUL

< UNIT DISASSEMBLY AND ASSEMBLY >

## UNIT DISASSEMBLY AND ASSEMBLY

### OVERHAUL

Component

INFOID:000000009885925

SEC.311•313•314•315

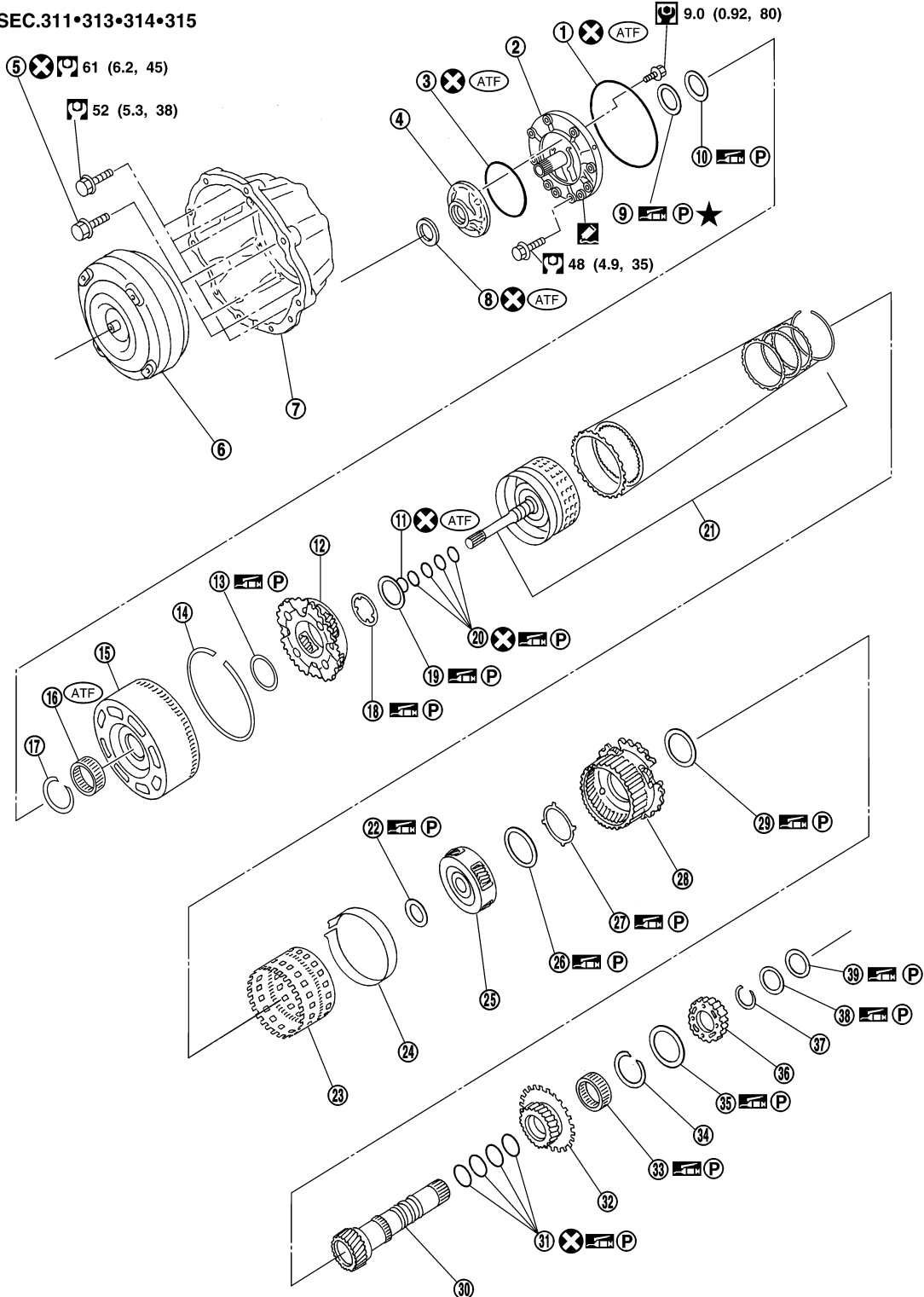

A  
B  
C  
TM  
E  
F  
G  
H  
I  
J  
K  
L  
M  
N  
O  
P

# OVERHAUL

## < UNIT DISASSEMBLY AND ASSEMBLY >

---

- |                           |                              |                                     |
|---------------------------|------------------------------|-------------------------------------|
| 1. O-ring                 | 2. Oil pump cover            | 3. O-ring                           |
| 4. Oil pump housing       | 5. Self-sealing bolts        | 6. Torque converter                 |
| 7. Converter housing      | 8. Oil pump housing oil seal | 9. Bearing race                     |
| 10. Needle bearing        | 11. O-ring                   | 12. Front carrier assembly          |
| 13. Needle bearing        | 14. Snap ring                | 15. Front sun gear                  |
| 16. 3rd one-way clutch    | 17. Snap ring                | 18. Bearing race                    |
| 19. Needle bearing        | 20. Seal ring                | 21. Input clutch assembly           |
| 22. Needle bearing        | 23. Rear internal gear       | 24. Brake band                      |
| 25. Mid carrier assembly  | 26. Needle bearing           | 27. Bearing race                    |
| 28. Rear carrier assembly | 29. Needle bearing           | 30. Mid sun gear                    |
| 31. Seal ring             | 32. Rear sun gear            | 33. 1st one-way clutch              |
| 34. Snap ring             | 35. Needle bearing           | 36. High and low reverse clutch hub |
| 37. Snap ring             | 38. Bearing race             | 39. Needle bearing                  |

# OVERHAUL

## < UNIT DISASSEMBLY AND ASSEMBLY >

SEC. 311•315

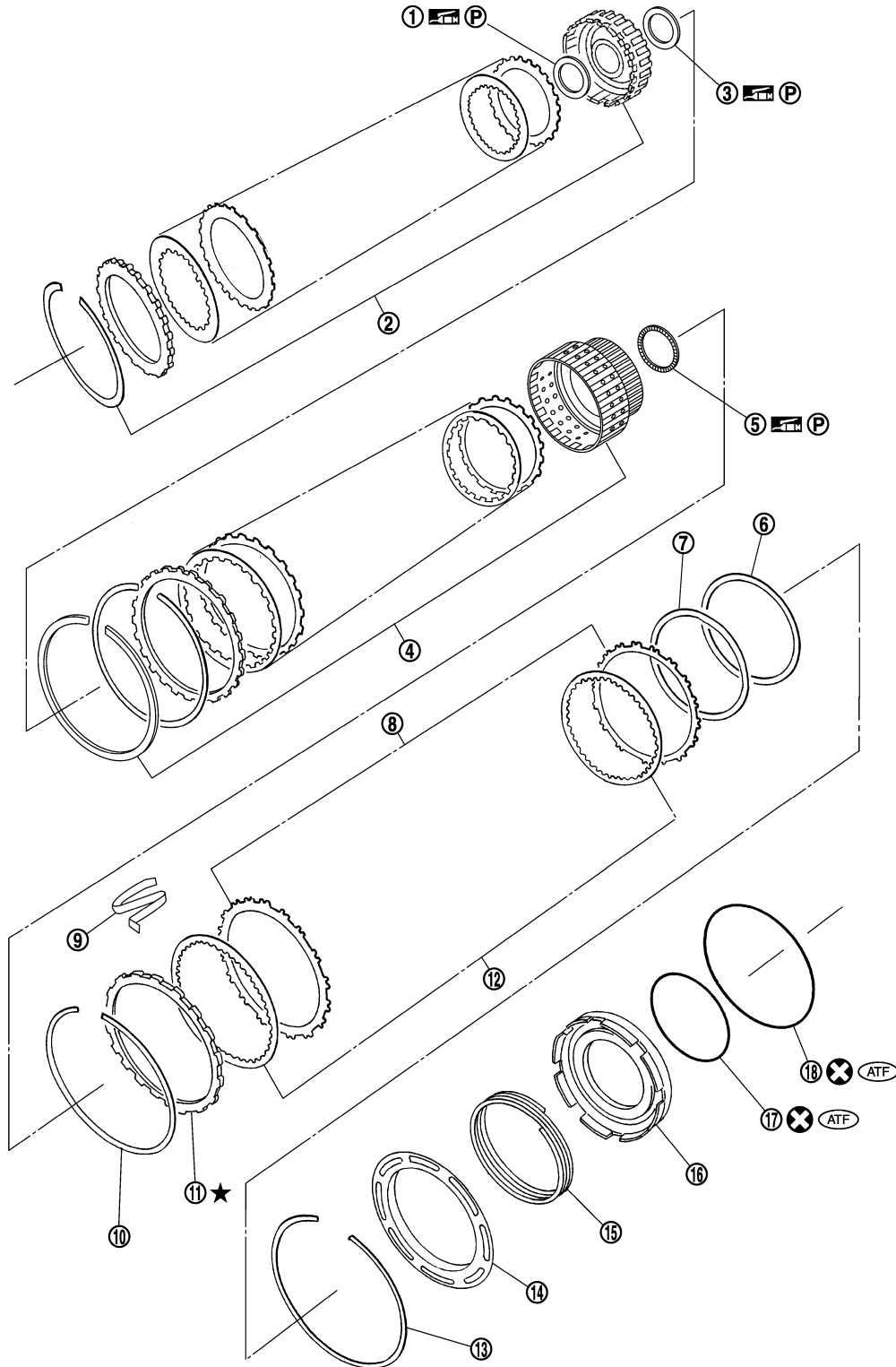

- |                             |   |                               |
|-----------------------------|---|-------------------------------|
| 1. Bearing race             | 2. High and low reverse clutch assembly | 3. Needle bearing             |
| 4. Direct clutch assembly   | 5. Needle bearing                       | 6. Reverse brake dish plate   |
| 7. Reverse brake dish plate | 8. Reverse brake driven plate           | 9. N-spring                   |
| 10. Snap ring               | 11. Reverse brake retaining plate       | 12. Reverse brake drive plate |

JSDIA1835ZZ

A  
B  
C  
TM  
E  
F  
G  
H  
I  
J  
K  
L  
M  
N  
O  
P

# OVERHAUL

## < UNIT DISASSEMBLY AND ASSEMBLY >

- |                          |                     |                   |
|--------------------------|---------------------|-------------------|
| 13. Snap ring            | 14. Spring retainer | 15. Return spring |
| 16. Reverse brake piston | 17. D-ring          | 18. D-ring        |

2WD

SEC. 313•314•317•319

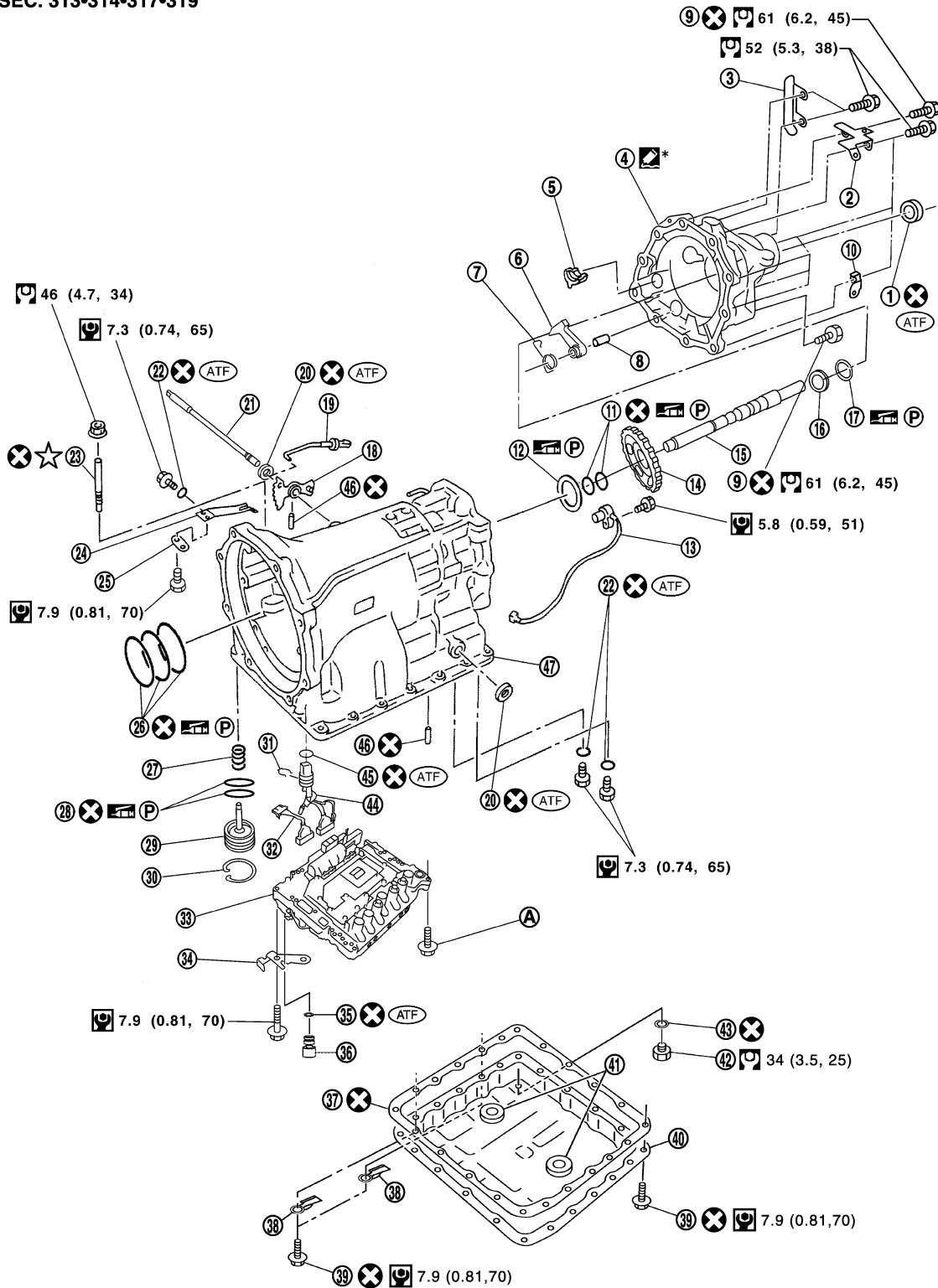

JSDIA1972GB

- |                  |                             |                      |
|------------------|-----------------------------|----------------------|
| 1. Rear oil seal | 2. Bracket                  | 3. Bracket           |
| 4. Adapter case  | 5. Parking actuator support | 6. Parking pawl      |
| 7. Return spring | 8. Pawl shaft               | 9. Self-sealing bolt |

# OVERHAUL

## < UNIT DISASSEMBLY AND ASSEMBLY >

- |                         |                                    |                            |    |
|-------------------------|------------------------------------|----------------------------|----|
| 10. Seal ring           | 11. Needle bearing                 | 12. Gasket                 |    |
| 13. Output speed sensor | 14. Parking gear                   | 15. Output shaft           | A  |
| 16. Bearing race        | 17. Needle bearing                 | 18. Manual plate           |    |
| 19. Parking rod         | 20. Manual shaft oil seal          | 21. Manual shaft           |    |
| 22. O-ring              | 23. Band servo anchor end pin      | 24. Detent spring          | B  |
| 25. Spacer              | 26. Seal ring                      | 27. Snap ring              |    |
| 28. Return spring       | 29. O-ring                         | 30. Servo assembly         |    |
| 31. Snap ring           | 32. Sub-harness                    | 33. Control valve with TCM | C  |
| 34. Bracket             | 35. O-ring                         | 36. Plug                   |    |
| 37. Oil pan gasket      | 38. Brackets                       | 39. Oil pan bolt           | TM |
| 40. Oil pan             | 41. Magnets                        | 42. Drain plug             |    |
| 43. Drain plug gasket   | 44. A/T assembly harness connector | 45. O-ring                 |    |
| 46. Retaining pin       | 47. Transmission case              |                            | E  |

A. Tightening must be done following the assembly procedure. Refer to [TM-281, "Assembly \(2\)"](#).

\* : Apply Genuine Anaerobic Liquid Gasket or equivalent.

4WD

A  
B  
C  
E  
F  
G  
H  
I  
J  
K  
L  
M  
N  
O  
P

# OVERHAUL

## < UNIT DISASSEMBLY AND ASSEMBLY >

SEC. 313•314•317•319

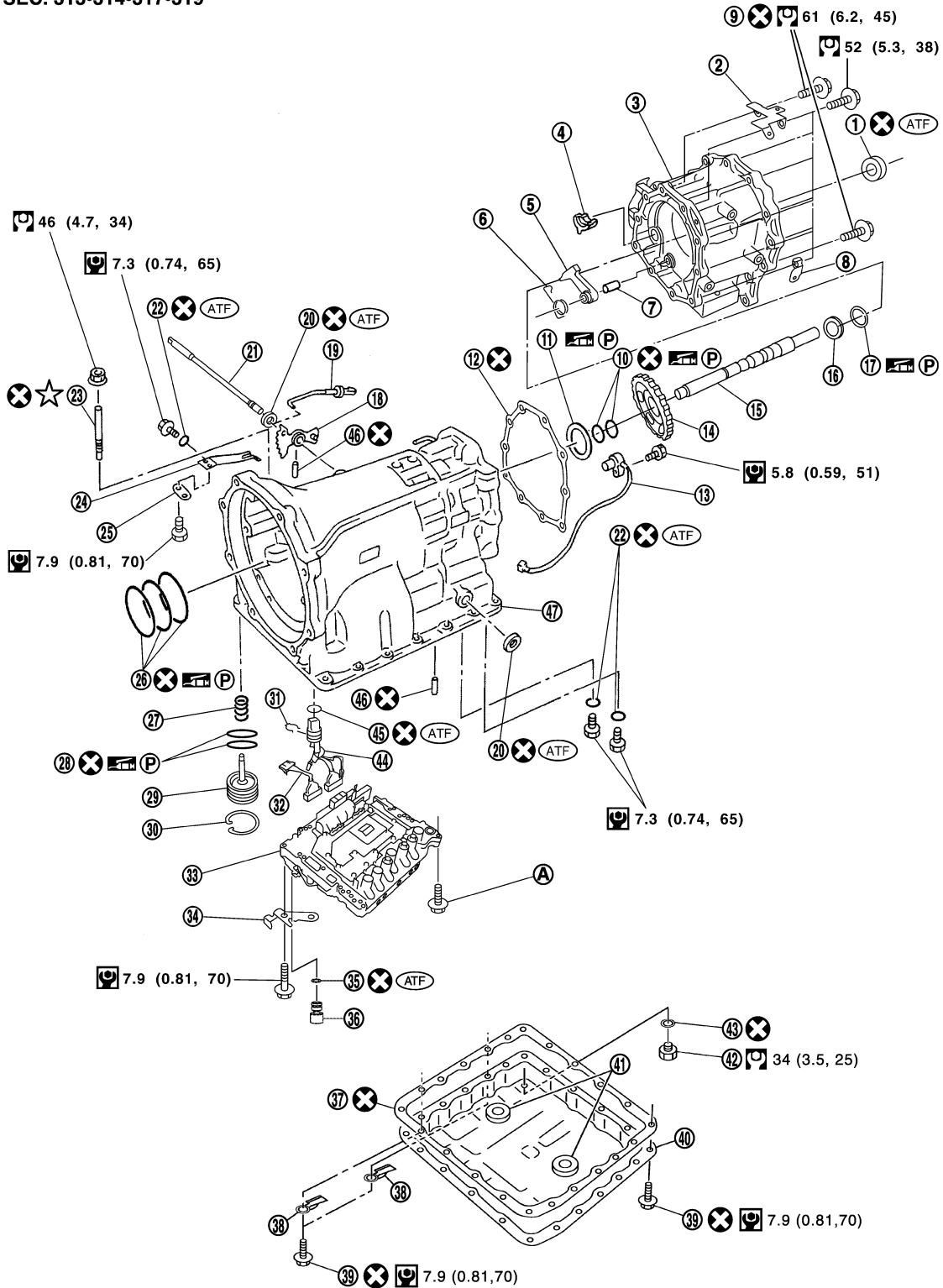

JSDIA1973GB

- |                             |                    |                      |
|-----------------------------|--------------------|----------------------|
| 1. Rear oil seal            | 2. Bracket         | 3. Adapter case      |
| 4. Parking actuator support | 5. Parking pawl    | 6. Return spring     |
| 7. Pawl shaft               | 8. Bracket         | 9. Self-sealing bolt |
| 10. Seal ring               | 11. Needle bearing | 12. Gasket           |
| 13. Output speed sensor     | 14. Parking gear   | 15. Output shaft     |
| 16. Bearing race            | 17. Needle bearing | 18. Manual plate     |

# OVERHAUL

## < UNIT DISASSEMBLY AND ASSEMBLY >

- |  |                                    |                            |    |
|--|------------------------------------|----------------------------|----|
| 19. Parking rod  | 20. Manual shaft oil seal          | 21. Manual shaft           | A  |
| 22. O-ring   | 23. Band servo anchor end pin      | 24. Detent spring          |    |
| 25. Spacer   | 26. Seal rings                     | 27. Return spring          |    |
| 28. O-ring   | 29. Servo assembly                 | 30. Snap ring              | B  |
| 31. Snap ring  | 32. Sub-harness                    | 33. Control valve with TCM |    |
| 34. Bracket  | 35. O-ring                         | 36. Plug                   |    |
| 37. Oil pan gasket   | 38. Brackets                       | 39. Oil pan bolt           | C  |
| 40. Oil pan  | 41. Magnets                        | 42. Drain plug             |    |
| 43. Drain plug gasket  | 44. A/T assembly harness connector | 45. O-ring                 |    |
| 46. Retaining pin  | 47. Transmission case              |                            | TM |
| A. Tightening must be done following the assembly procedure. Refer to <a href="#">TM-281, "Assembly (2)"</a> . |                                    |                            |    |

E  
F  
G  
H  
I  
J  
K  
L  
M  
N  
O  
P

# OVERHAUL

## < UNIT DISASSEMBLY AND ASSEMBLY >

### Oil Channel

INFOID:00000009885926

#### 2WD models

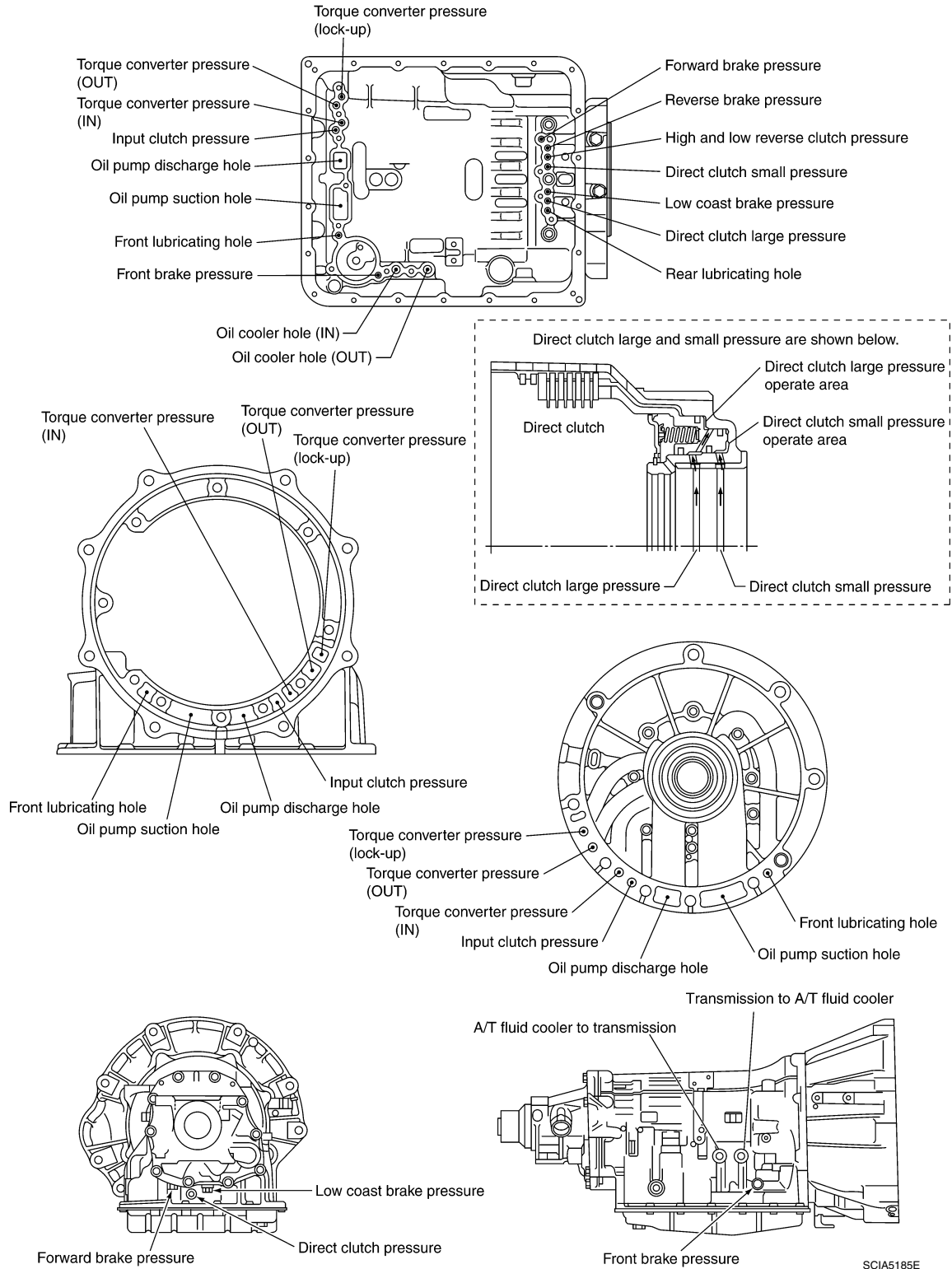

SCIA5185E



# OVERHAUL

## < UNIT DISASSEMBLY AND ASSEMBLY >

### 4WD models

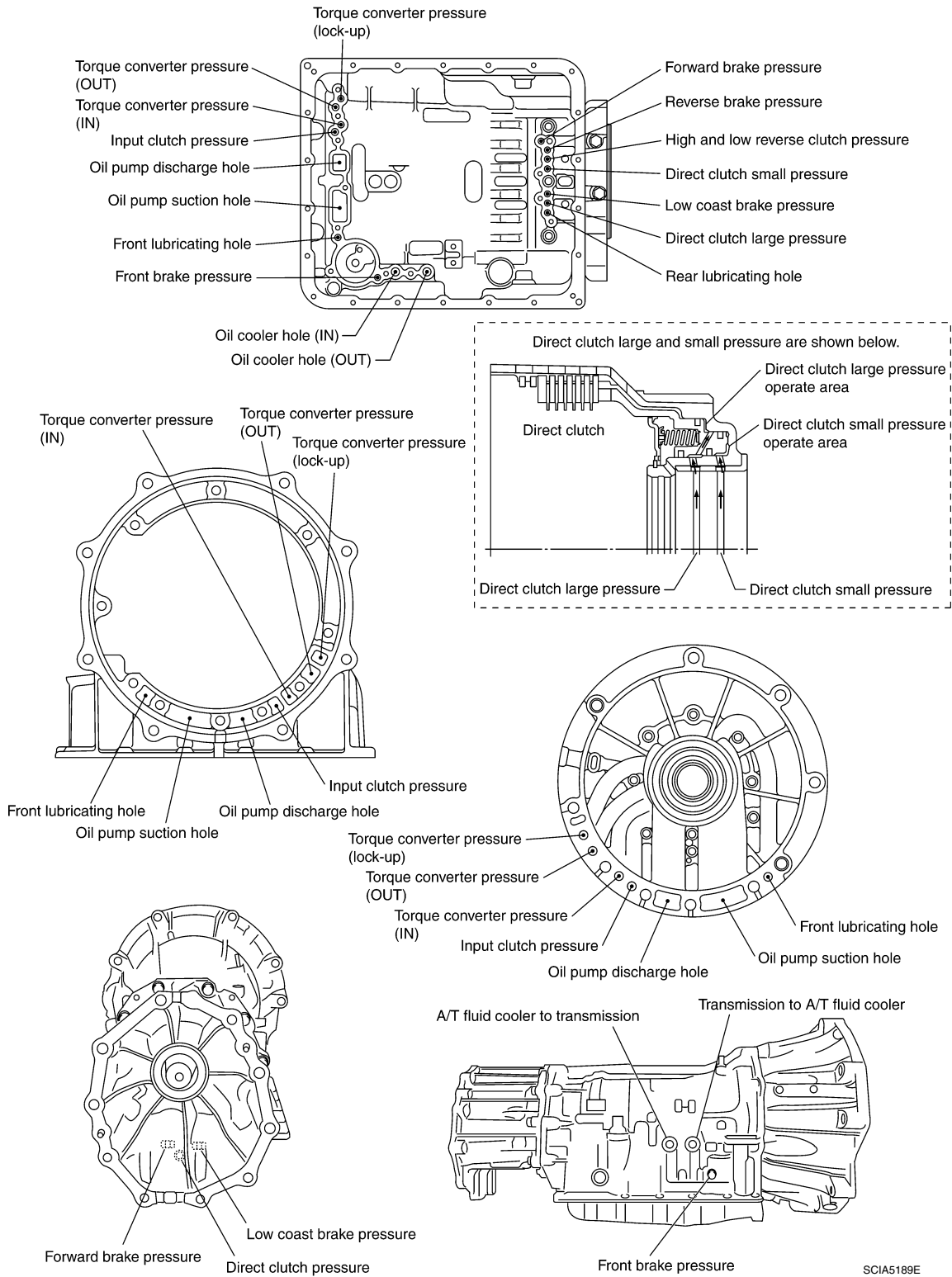

A  
B  
C  
TM  
E  
F  
G  
H  
I  
J  
K  
L  
M  
N  
O  
P

# OVERHAUL

< UNIT DISASSEMBLY AND ASSEMBLY >

## Location of Adjusting Shims, Needle Bearings, Thrust Washers and Snap Rings

INFOID:000000009885927

2WD models

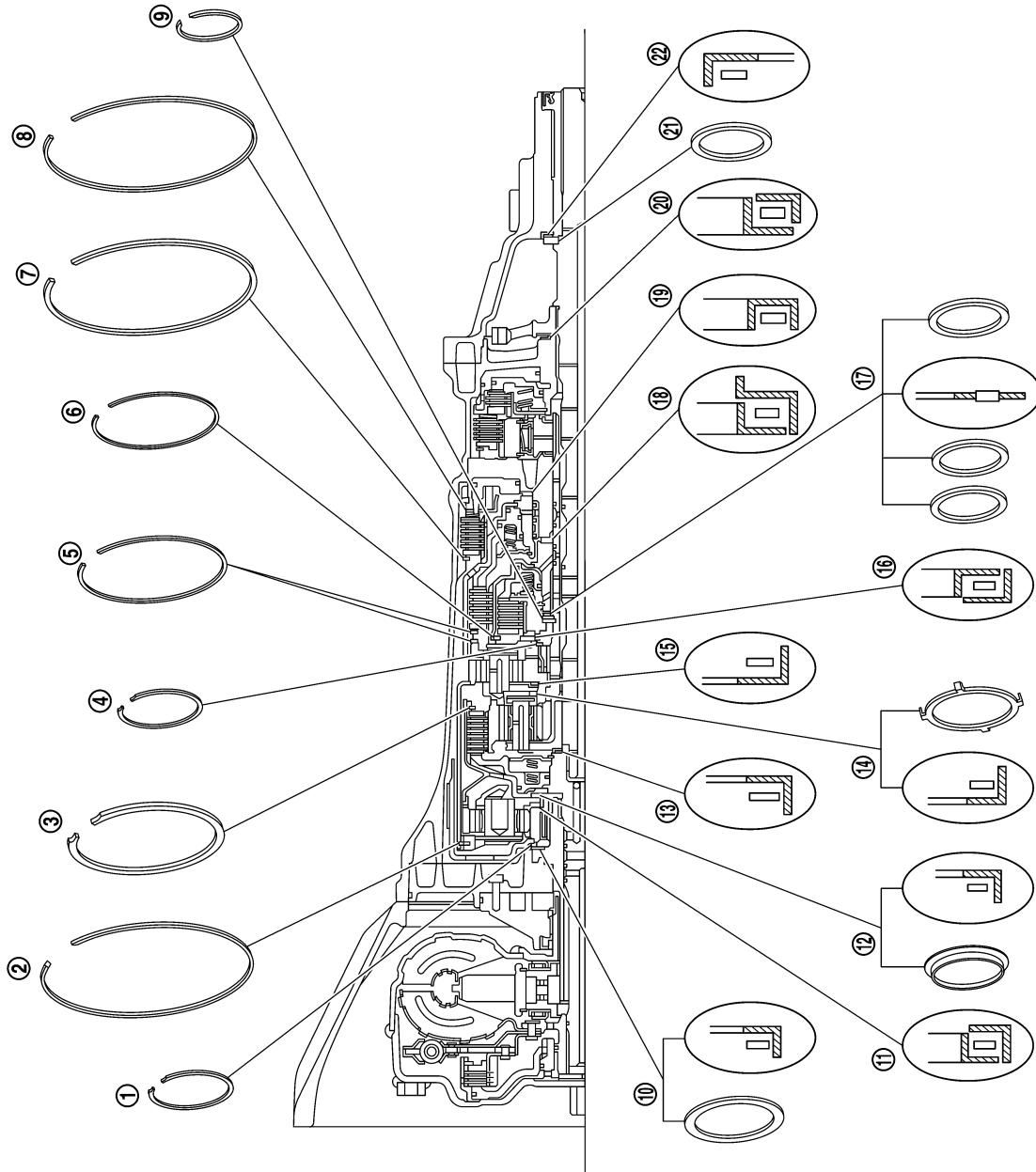

WCIA0560E

- |                                    |                                    |                                    |
|------------------------------------|------------------------------------|------------------------------------|
| 1. Outer diameter 68 mm (2.68 in)  | 2. Outer diameter 182 mm (7.17 in) | 3. Outer diameter 172 mm (6.77 in) |
| 4. Outer diameter 71 mm (2.80 in)  | 5. Outer diameter 169 mm (6.65 in) | 6. Outer diameter 134 mm (5.28 in) |
| 7. Outer diameter 181 mm (7.13 in) | 8. Outer diameter 181 mm (7.13 in) | 9. Outer diameter 48 mm (1.89 in)  |

# OVERHAUL

## < UNIT DISASSEMBLY AND ASSEMBLY >

- |                                    |                                    |                                    |
|------------------------------------|------------------------------------|------------------------------------|
| 10. Outer diameter 80 mm (3.15 in) | 11. Outer diameter 77 mm (3.03 in) | 12. Outer diameter 77 mm (3.03 in) |
| 13. Outer diameter 47 mm (1.85 in) | 14. Outer diameter 84 mm (3.31 in) | 15. Outer diameter 84 mm (3.31 in) |
| 16. Outer diameter 92 mm (3.62 in) | 17. Outer diameter 60 mm (2.36 in) | 18. Outer diameter 63 mm (2.48 in) |
| 19. Outer diameter 92 mm (3.62 in) | 20. Outer diameter 65 mm (2.56 in) | 21. Bearing race                   |
| 22. Outer diameter 60 mm (2.36 in) |                                    |                                    |

4WD models

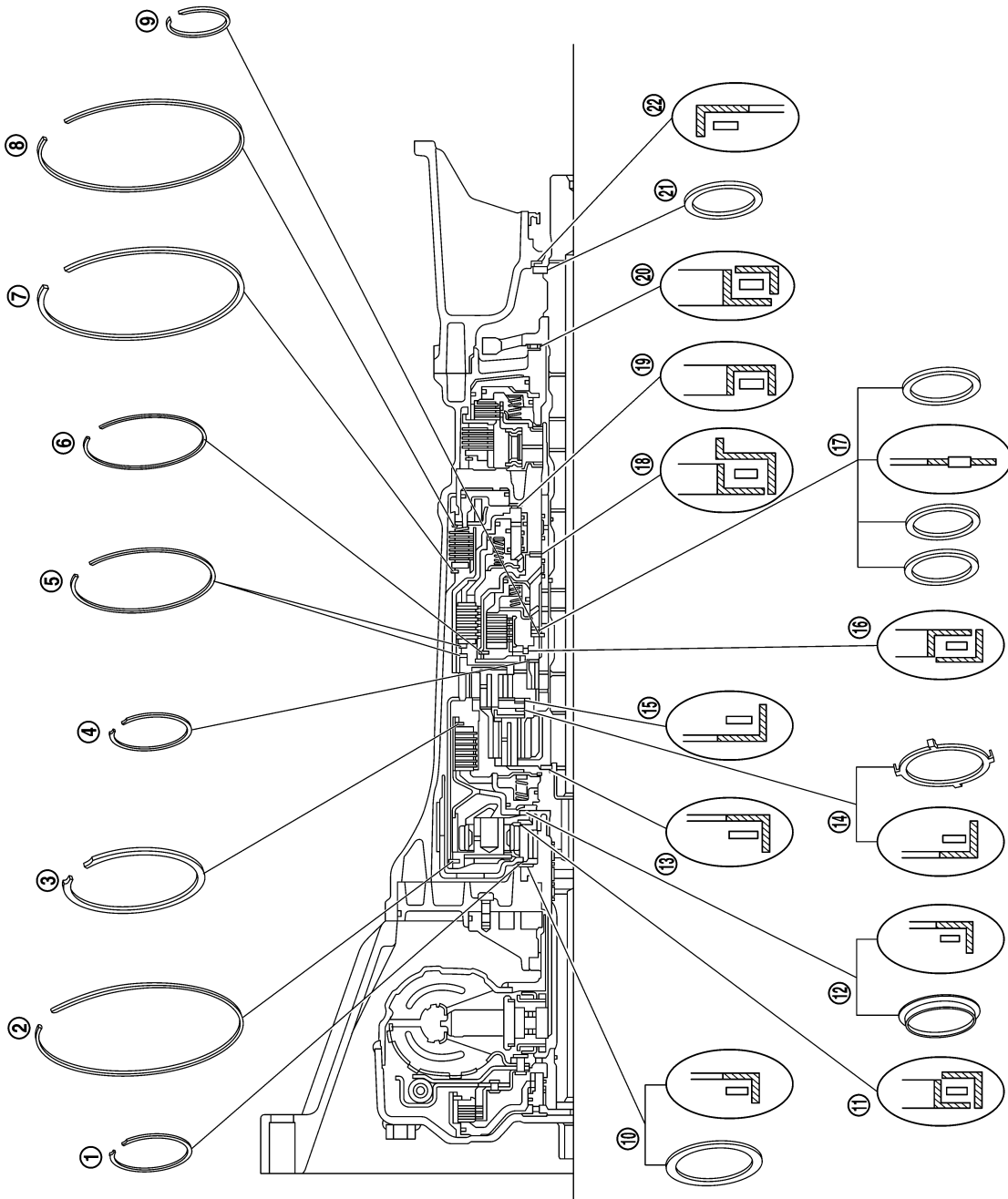

A  
B  
C  
TM  
E  
F  
G  
H  
I  
J  
K  
L  
M  
N  
O  
P

WCIA0561E

# OVERHAUL

## < UNIT DISASSEMBLY AND ASSEMBLY >

---

- |                                    |                                    |                                    |
|------------------------------------|------------------------------------|------------------------------------|
| 1. Outer diameter 68 mm (2.68 in)  | 2. Outer diameter 182 mm (7.17 in) | 3. Outer diameter 172 mm (6.77 in) |
| 4. Outer diameter 71 mm (2.80 in)  | 5. Outer diameter 169 mm (6.65 in) | 6. Outer diameter 134 mm (5.28 in) |
| 7. Outer diameter 181 mm (7.13 in) | 8. Outer diameter 181 mm (7.13 in) | 9. Outer diameter 48 mm (1.89 in)  |
| 10. Outer diameter 80 mm (3.15 in) | 11. Outer diameter 77 mm (3.03 in) | 12. Outer diameter 77 mm (3.03 in) |
| 13. Outer diameter 47 mm (1.85 in) | 14. Outer diameter 84 mm (3.31 in) | 15. Outer diameter 84 mm (3.31 in) |
| 16. Outer diameter 92 mm (3.62 in) | 17. Outer diameter 60 mm (2.36 in) | 18. Outer diameter 63 mm (2.48 in) |
| 19. Outer diameter 92 mm (3.62 in) | 20. Outer diameter 65 mm (2.56 in) | 21. Bearing race                   |
| 22. Outer diameter 60 mm (2.36 in) |                                    |                                    |

# DISASSEMBLY

< UNIT DISASSEMBLY AND ASSEMBLY >

## DISASSEMBLY

### Disassembly

INFOID:00000009885928

#### CAUTION:

Do not disassemble parts behind Drum Support. Refer to [TM-10, "Cross-Sectional View \(2WD models\)"](#).

1. Drain A/T fluid through drain plug.
2. Remove torque converter by holding it firmly and turing while pulling straight out.

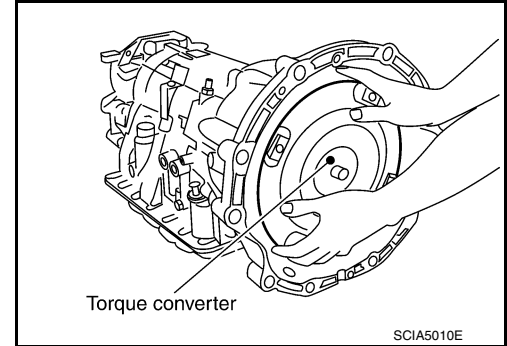

3. Check torque converter one-way clutch using a check tool as shown.
  - a. Insert a check tool into the groove of bearing support built into one-way clutch outer race.
  - b. While holding bearing support with a check tool, rotate one-way clutch spline using suitable tool.
  - c. Make sure that inner race rotates clockwise only. If not, replace torque converter assembly.

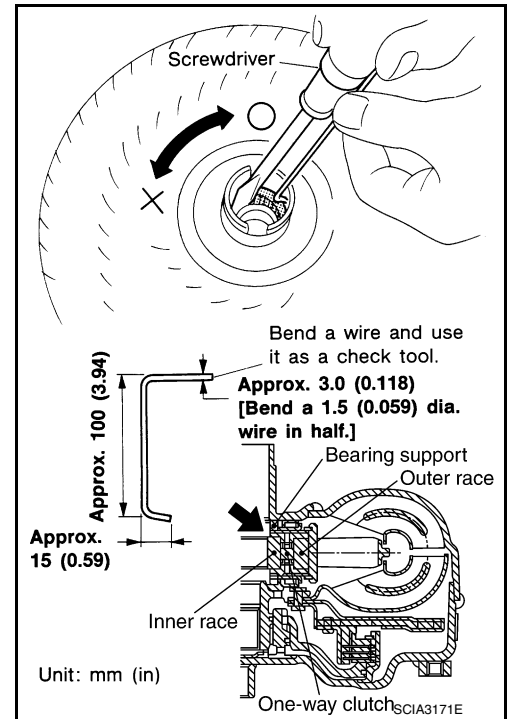

4. Remove bolts and converter housing from transmission case.

#### CAUTION:

Do not scratch converter housing.

- Self-sealing bolt (A)

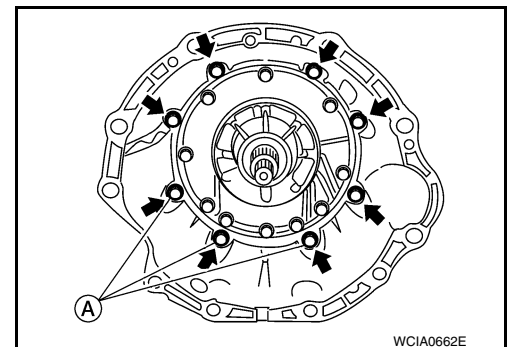

# DISASSEMBLY

## < UNIT DISASSEMBLY AND ASSEMBLY >

5. Remove O-ring from input clutch assembly.

**CAUTION:**  
Do not reuse O-ring.

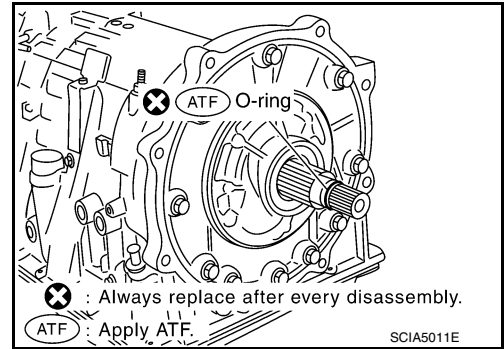

6. Remove oil pump assembly to transmission case bolts.

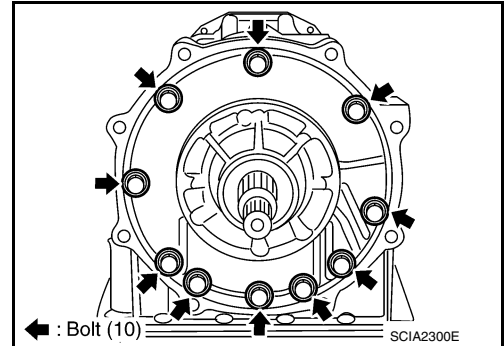

7. Remove the oil pump assembly evenly from the transmission case using Tools.

**Tool number : ST25850000 (J-25721-A)**

**CAUTION:**

- Fully tighten the sliding hammer screws.
- Make sure that bearing race is installed to the oil pump assembly edge surface.

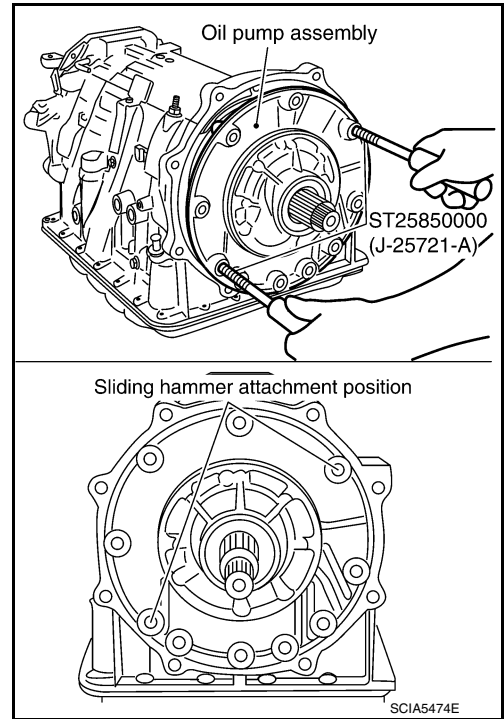

8. Remove O-ring from oil pump assembly.

**CAUTION:**  
Do not reuse O-ring.

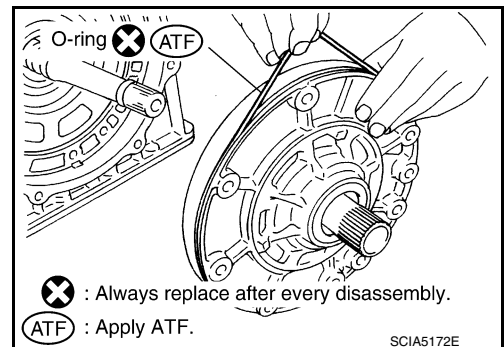

# DISASSEMBLY

## < UNIT DISASSEMBLY AND ASSEMBLY >

9. Remove bearing race from oil pump assembly.

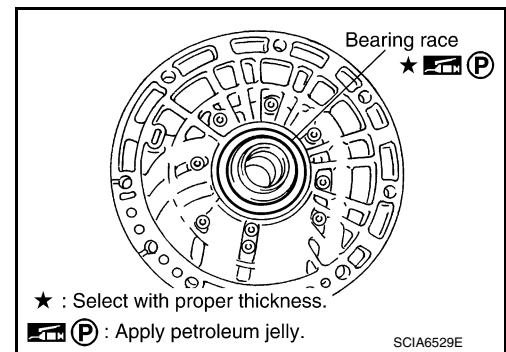

10. Remove needle bearing from front sun gear.

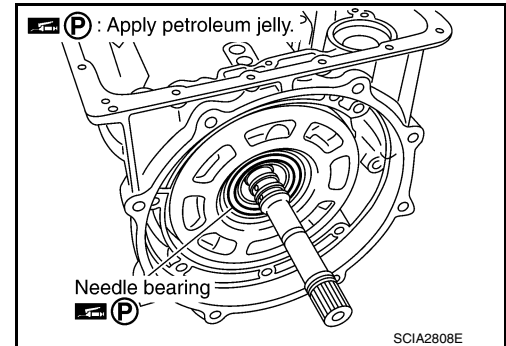

11. Remove front sun gear assembly from front carrier assembly.  
**NOTE:**  
Remove front sun gear by rotating it left and right.

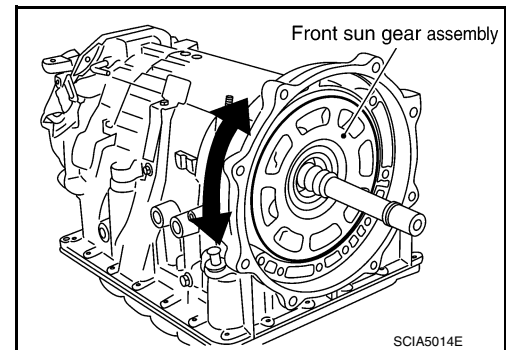

12. Remove seal rings from input clutch assembly.

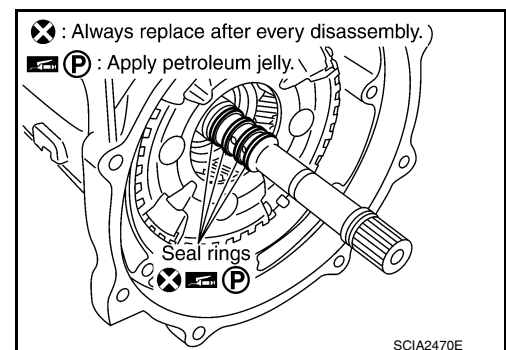

13. Remove front carrier assembly (with input clutch assembly and rear internal gear) from rear carrier assembly.  
**CAUTION:**  
Do not remove it with needle bearing.

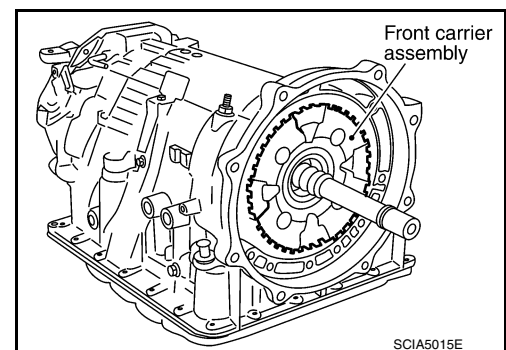

A  
B  
C  
TM  
E  
F  
G  
H  
I  
J  
K  
L  
M  
N  
O  
P

# DISASSEMBLY

## < UNIT DISASSEMBLY AND ASSEMBLY >

14. Loosen lock nut and remove band servo anchor end pin from transmission case.

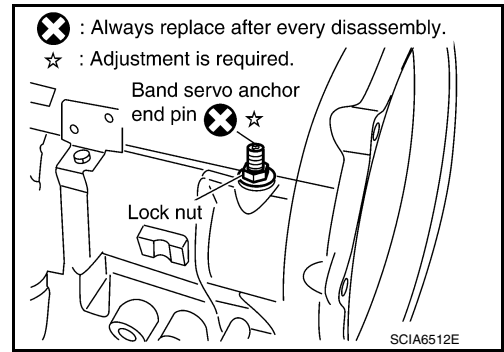

15. Remove brake band from transmission case.

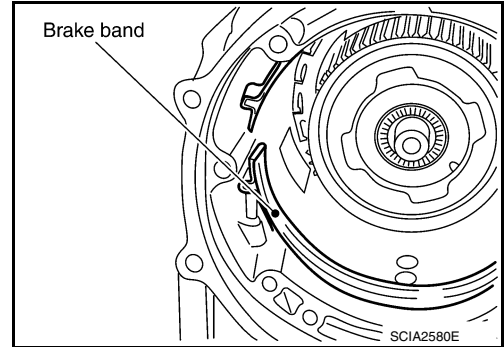

### CAUTION:

- To prevent brake linings from cracking or peeling, do not stretch the flexible band unnecessarily. When removing the brake band, always secure it with a clip as shown.
- Check brake band facing for damage, cracks, wear or burns.

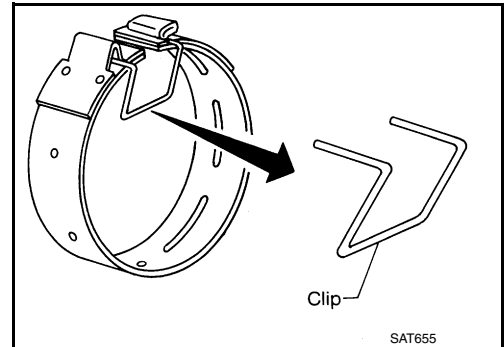

16. Remove mid carrier assembly and rear carrier assembly as a unit.

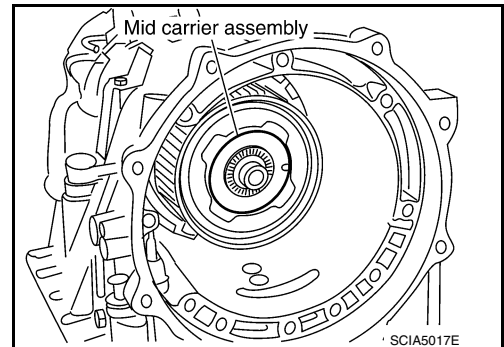



# DISASSEMBLY

## < UNIT DISASSEMBLY AND ASSEMBLY >

17. Remove mid carrier assembly from rear carrier assembly.

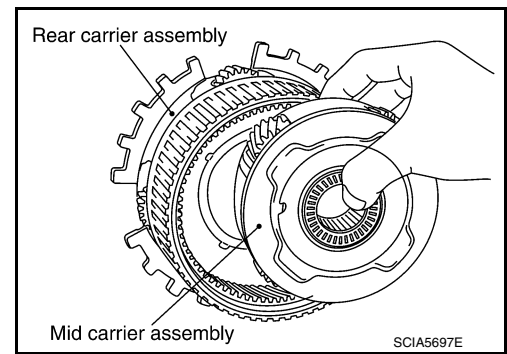

18. Remove needle bearing (front side) from mid carrier assembly.

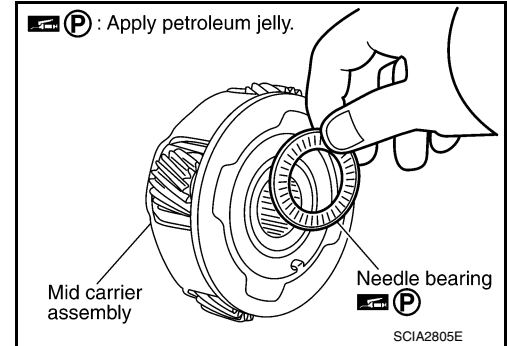

19. Remove needle bearing (rear side) from mid carrier assembly.

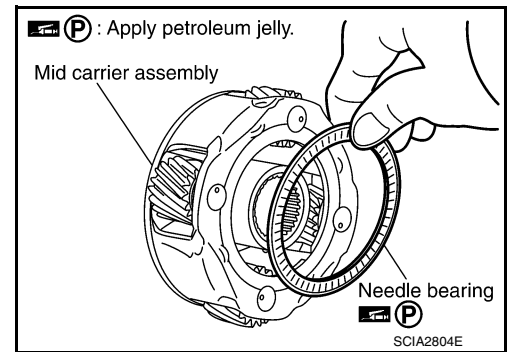

20. Remove bearing race from rear carrier assembly.

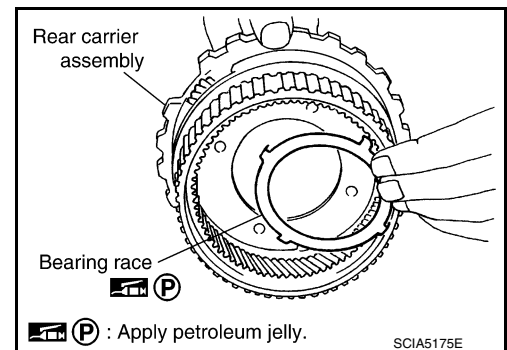

21. Remove needle bearing from rear carrier assembly.

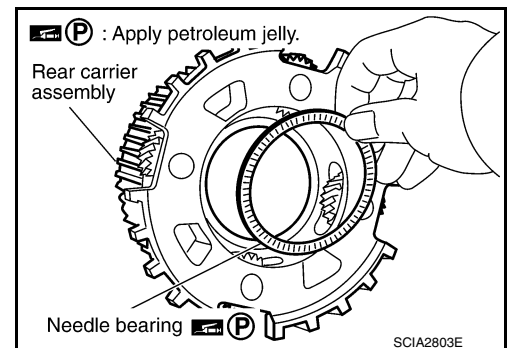

A  
B  
C  
TM  
E  
F  
G  
H  
I  
J  
K  
L  
M  
N  
O  
P

# DISASSEMBLY

## < UNIT DISASSEMBLY AND ASSEMBLY >

22. Remove mid sun gear assembly, rear sun gear assembly and high and low reverse clutch hub as a unit.

**CAUTION:**

Remove them with bearing race and needle bearing.

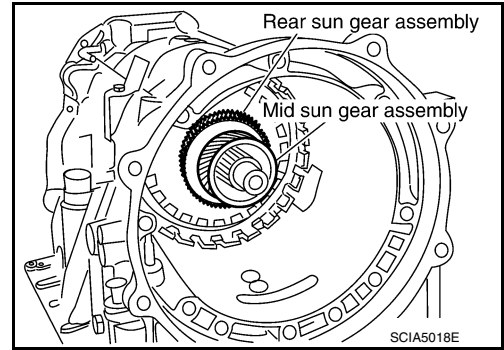

23. Remove high and low reverse clutch assembly from direct clutch assembly.

**CAUTION:**

Make sure that needle bearing is installed to the high and low reverse clutch assembly edge surface.

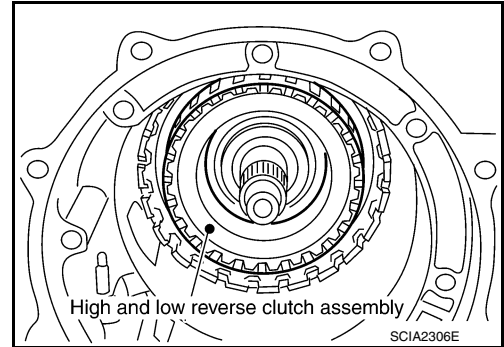

24. Remove needle bearing from drum support.

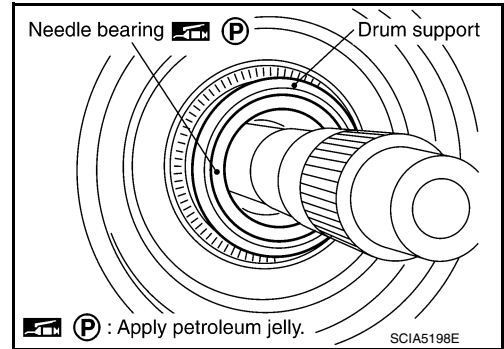

25. Remove direct clutch assembly from reverse brake.

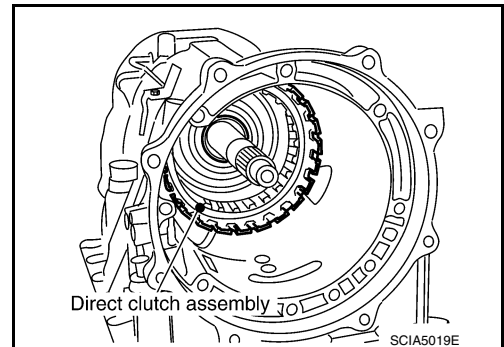

26. Remove snap ring from A/T assembly harness connector.

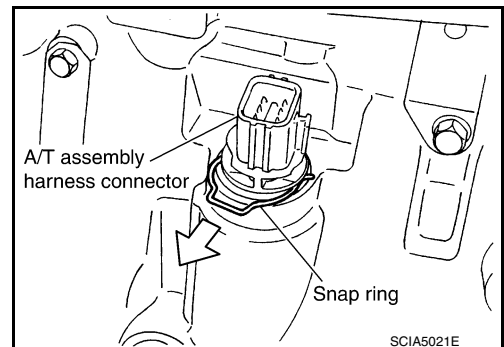

# DISASSEMBLY

## < UNIT DISASSEMBLY AND ASSEMBLY >

27. Push A/T assembly harness connector.

**CAUTION:**

**Do not damage connector.**

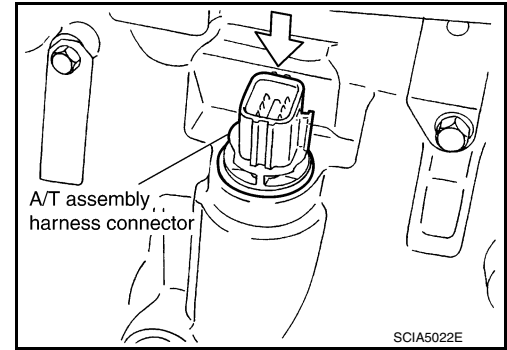

28. Remove oil pan and oil pan gasket. Refer to [TM-199, "Removal and Installation"](#).

29. Check foreign materials in oil pan to help determine causes of malfunction. If the A/T fluid is very dark, smells burned, or contains foreign particles, the frictional material (clutches, band) may need replacement. A tacky film that will not wipe clean indicates varnish build up. Varnish can cause valves, servo, and clutches to stick and can inhibit pump pressure.

• **If frictional material is detected, perform A/T fluid cooler cleaning. Refer to [TM-176, "A/T Fluid Cooler Cleaning"](#).**

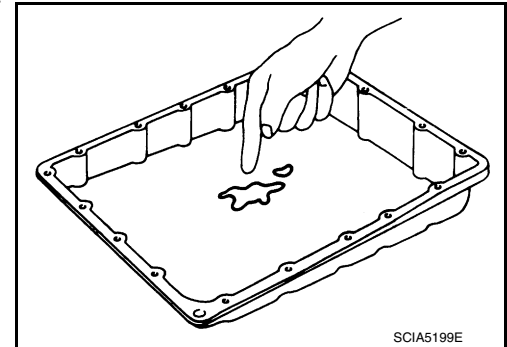

30. Remove magnets from oil pan.

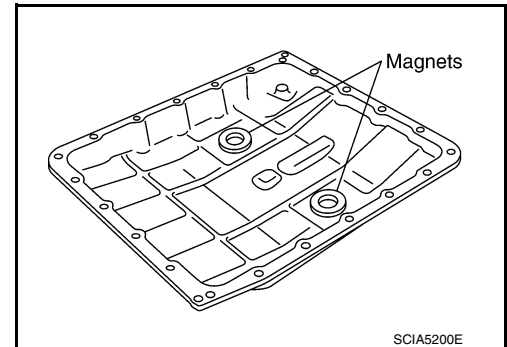

31. Disconnect output speed sensor connector (1).

**CAUTION:**

**Do not damage connector.**

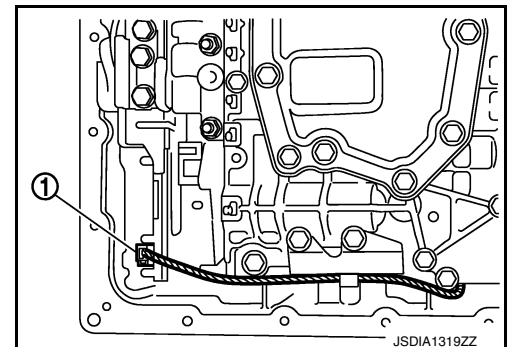

A  
B  
C  
TM  
E  
F  
G  
H  
I  
J  
K  
L  
M  
N  
O  
P

# DISASSEMBLY

## < UNIT DISASSEMBLY AND ASSEMBLY >

32. Straighten terminal clip (←) to free output speed sensor harness.

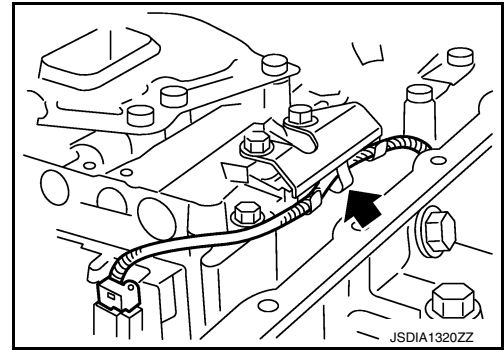

33. Remove bolts (A), (B) and (C) from control valve with TCM.

• ← : Front

Bolt symbol	Length mm (in)	Number of bolts
A	42 (1.65)	5
B	55 (2.17)	6
C	40 (1.57)	1

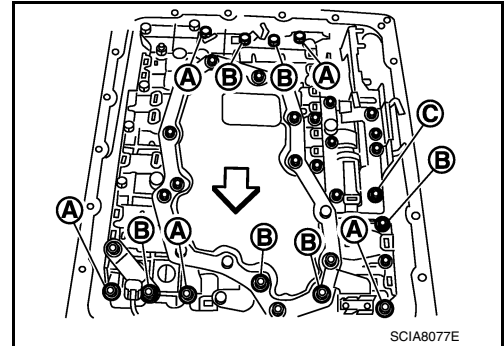

34. Remove control valve with TCM from transmission case.

**CAUTION:**

**When removing, be careful with the manual valve notch and manual plate height. Remove it vertically.**

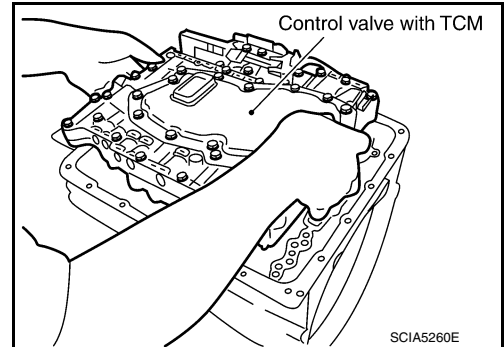

35. Remove plug (1) with bracket (2) from control valve with TCM.

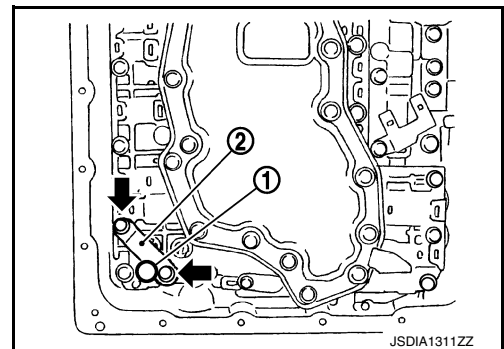

36. Remove bracket (1) from plug (2).

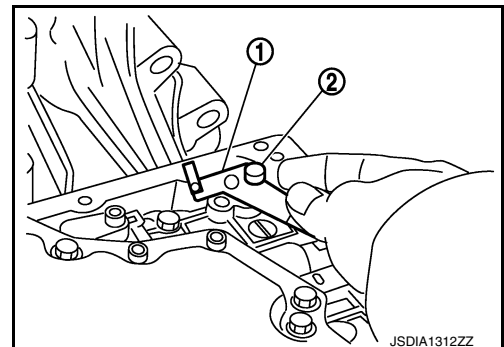

# DISASSEMBLY

## < UNIT DISASSEMBLY AND ASSEMBLY >

37. Remove O-ring (1) from plug (2).

**CAUTION:**

**Do not reuse O-ring.**

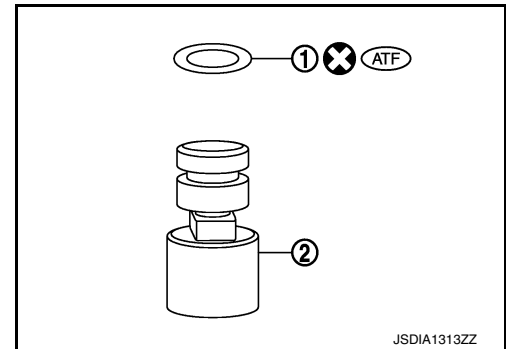

38. Remove O-ring from A/T assembly harness connector.

**CAUTION:**

**Do not reuse O-ring.**

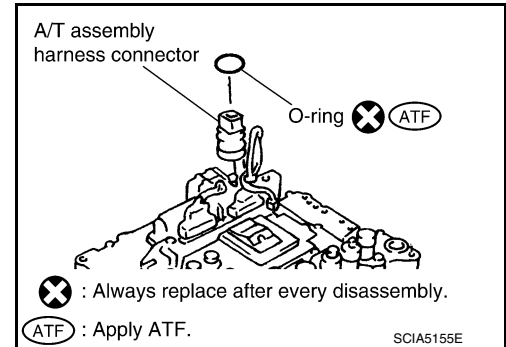

39. Disconnect TCM connectors.

**CAUTION:**

**Do not damage connectors.**

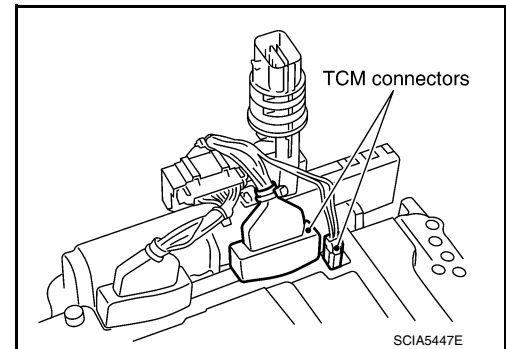

40. Remove A/T assembly harness connector from control valve with TCM using suitable tool.

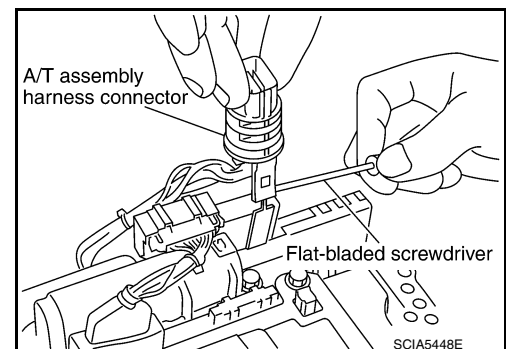

41. Disconnect TCM connector (1) and transmission range switch connector (2).

**CAUTION:**

**Do not damage connectors.**

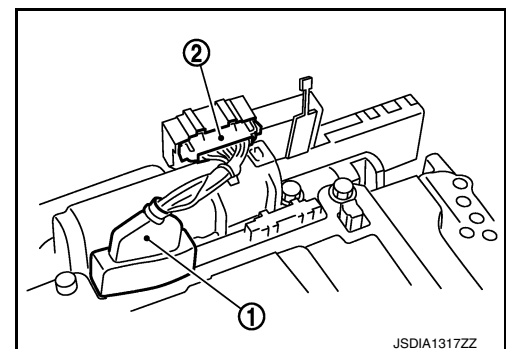

# DISASSEMBLY

## < UNIT DISASSEMBLY AND ASSEMBLY >

42. Remove rear extension assembly (2WD models) or adapter case assembly (4WD models) according to the following procedures.

a. **2WD models**

i. Remove tightening bolts (⬅) for rear extension assembly and transmission case.

- Brackets (1)
- Self-sealing bolts (2)

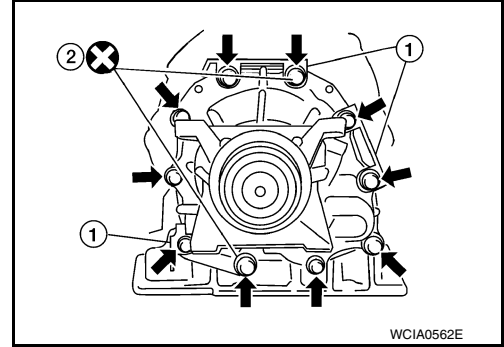

ii. Tap rear extension assembly with soft hammer.

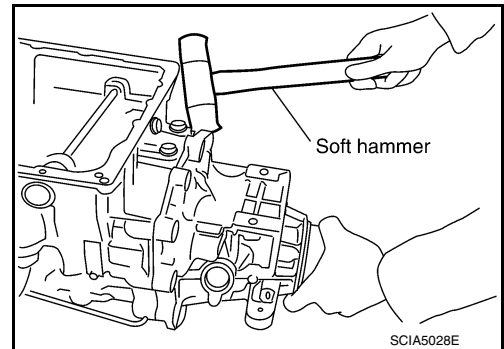

iii. Remove rear extension assembly (with needle bearing) from transmission case.

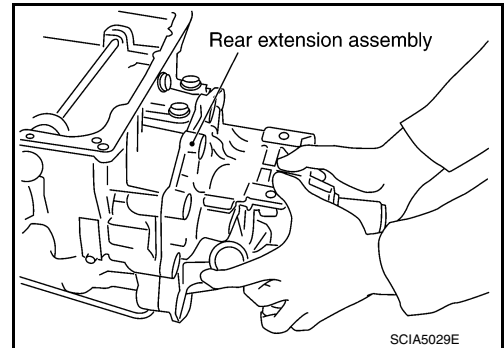

# DISASSEMBLY

## < UNIT DISASSEMBLY AND ASSEMBLY >

### b. 4WD models

- i. Remove tightening bolts (←) for adapter case assembly and transmission case.
- Brackets (1)
  - Self-sealing bolt (2)

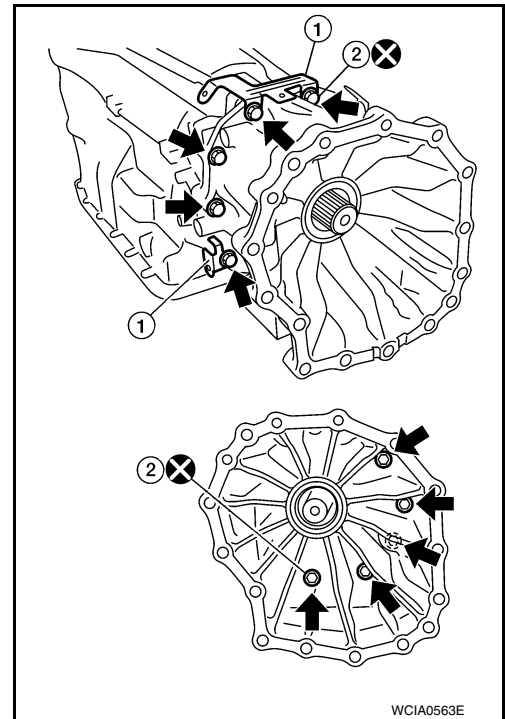

- ii. Tap adapter case assembly using suitable tool.

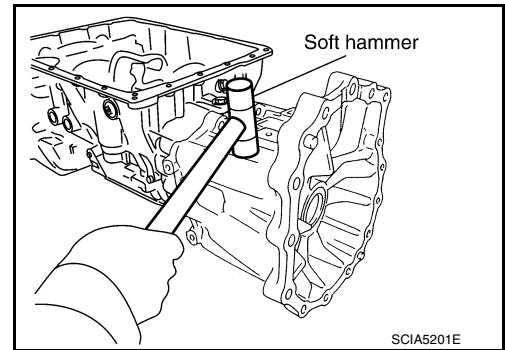

- iii. Remove adapter case assembly (with needle bearing) from transmission case.

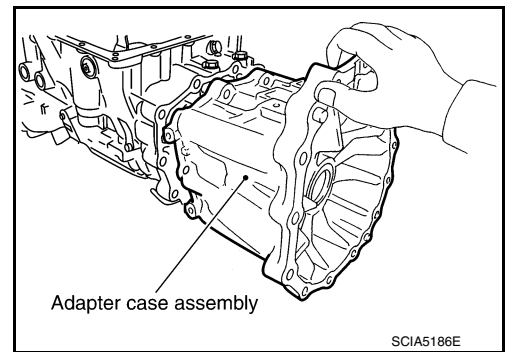

- iv. Remove gasket from transmission case.

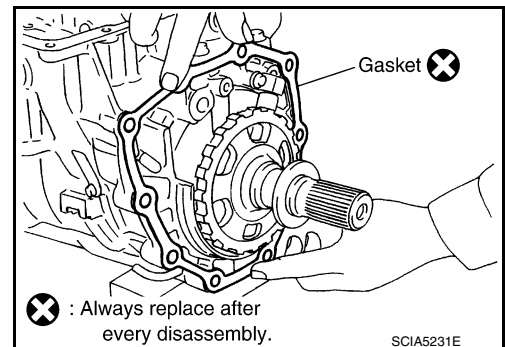

A  
B  
C  
TM  
E  
F  
G  
H  
I  
J  
K  
L  
M  
N  
O  
P

# DISASSEMBLY

## < UNIT DISASSEMBLY AND ASSEMBLY >

43. Remove bearing race from output shaft.

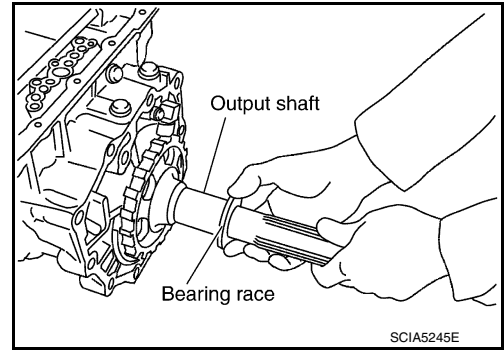

44. Remove output shaft from transmission case by rotating left and right.

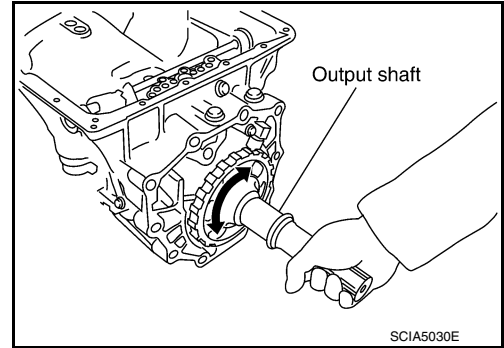

45. Remove parking gear from output shaft.

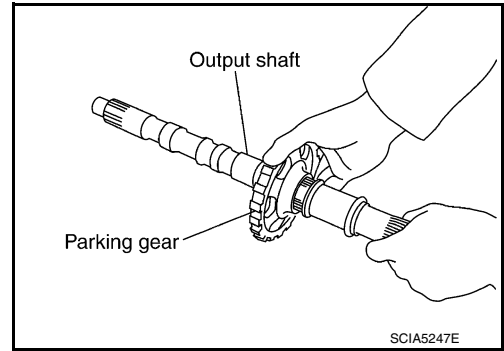

46. Remove seal rings from output shaft.

**CAUTION:**  
Do not reuse seal rings.

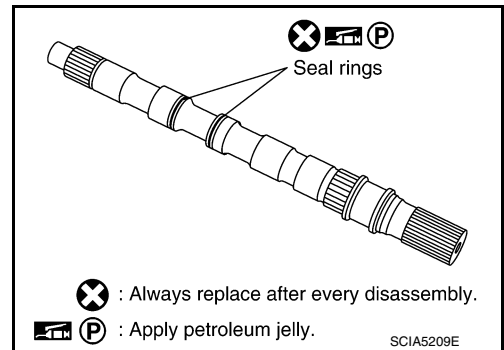

47. Remove needle bearing from transmission case.

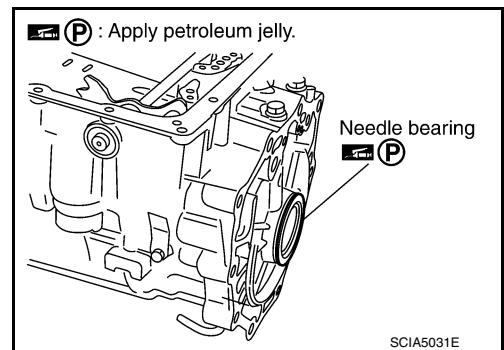



# DISASSEMBLY

## < UNIT DISASSEMBLY AND ASSEMBLY >

48. Remove output speed sensor (1) from transmission case.

← : Bolt

**CAUTION:**

- Do not subject it to impact by dropping or hitting it.
- Do not disassemble.
- Do not allow metal filings or any foreign material to get on the sensor's front edge magnetic area.
- Do not place in an area affected by magnetism.

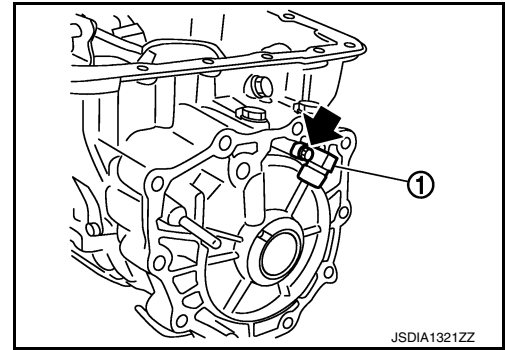

49. Remove reverse brake snap ring using two flat-bladed screwdrivers.

**NOTE:**

Press out snap ring from the transmission case oil pan side gap using a flat-bladed screwdriver, and remove it using a another screwdriver.

50. Remove reverse brake retaining plate from transmission case.

- Check facing for burns, cracks or damage. If necessary, replace the plate.

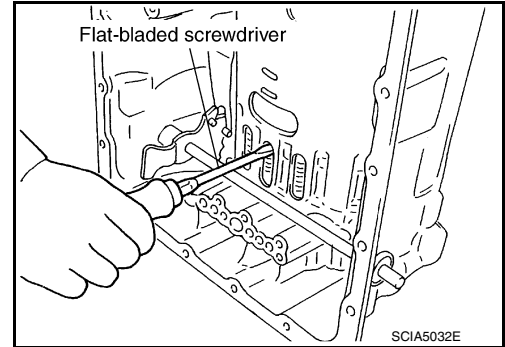

51. Remove N-spring from transmission case.

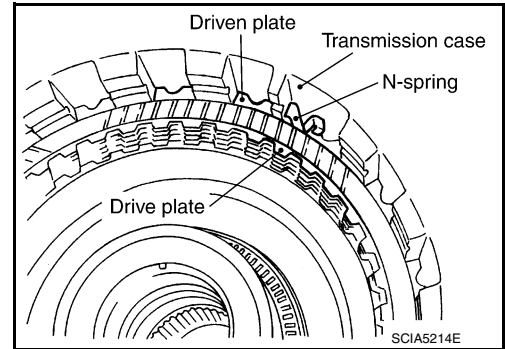

52. Remove reverse brake drive plates, driven plates and dish plate from transmission case.

- Check facing for burns, cracks or damage. If necessary, replace the plate.

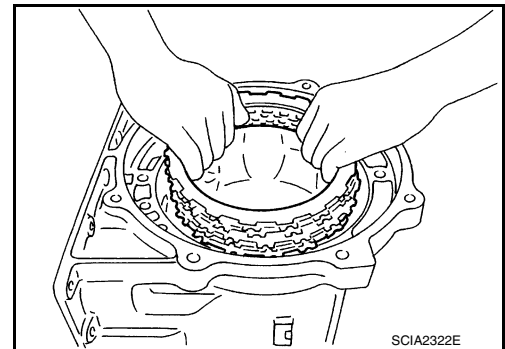

53. Remove snap ring using suitable tool.

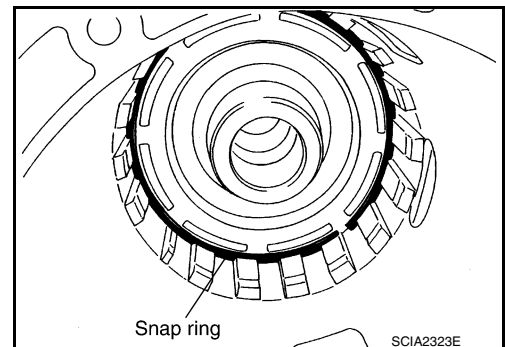

A  
B  
C  
TM  
E  
F  
G  
H  
I  
J  
K  
L  
M  
N  
O  
P

# DISASSEMBLY

## < UNIT DISASSEMBLY AND ASSEMBLY >

54. Remove spring retainer and return spring from transmission case.

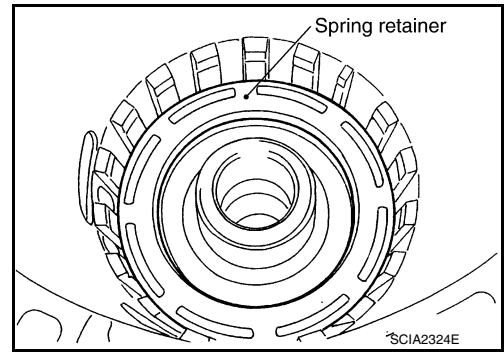

55. Remove seal rings from drum support.

**CAUTION:**

**Do not reuse seal rings.**

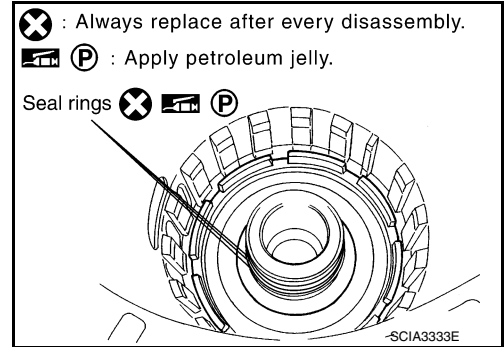

56. Remove needle bearing from drum support edge surface.

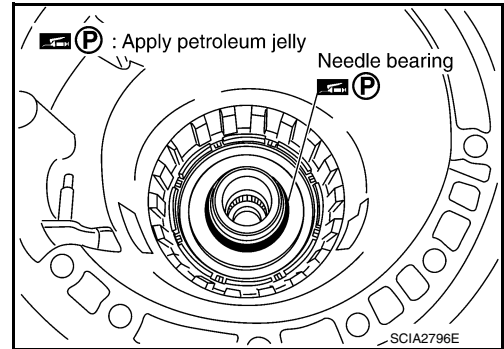

57. Remove reverse brake piston from transmission case using compressed air. Refer to [TM-224, "Oil Channel"](#).

**CAUTION:**

**Care should be taken not to abruptly blow air. It makes the piston incline, and as a result, it becomes hard to disassemble the pistons.**

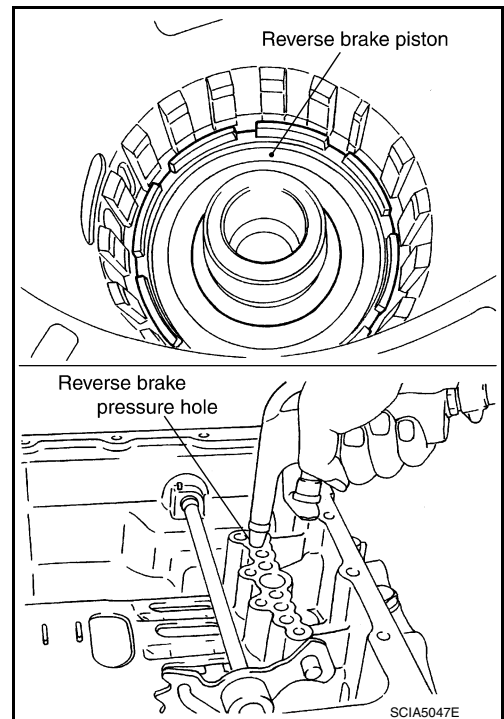

# DISASSEMBLY

## < UNIT DISASSEMBLY AND ASSEMBLY >

58. Remove D-rings from reverse brake piston.

**CAUTION:**

**Do not reuse D-rings.**

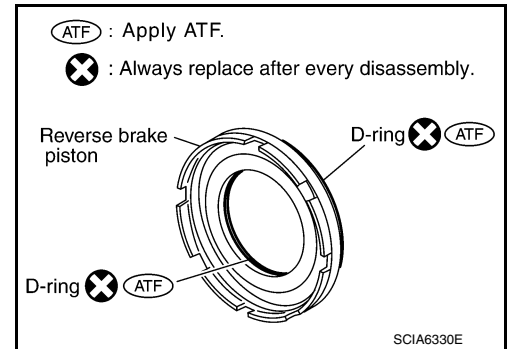

59. Knock out retaining pin using suitable tool.

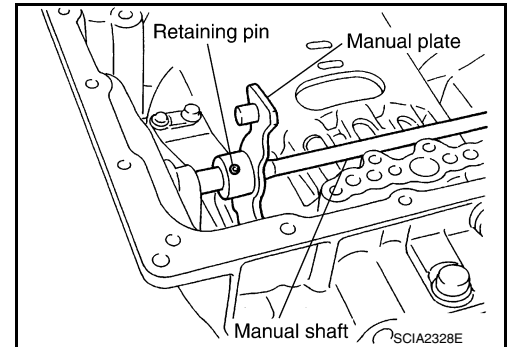

60. Remove manual shaft retaining pin using suitable tool.

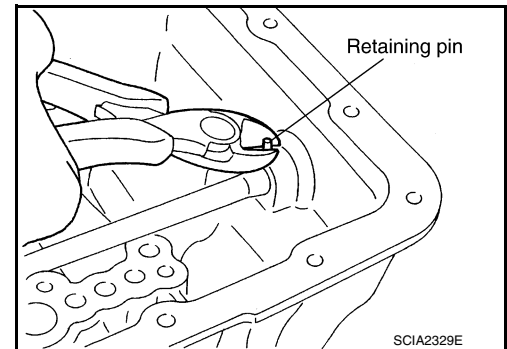

61. Remove manual plate (with parking rod) from manual shaft.

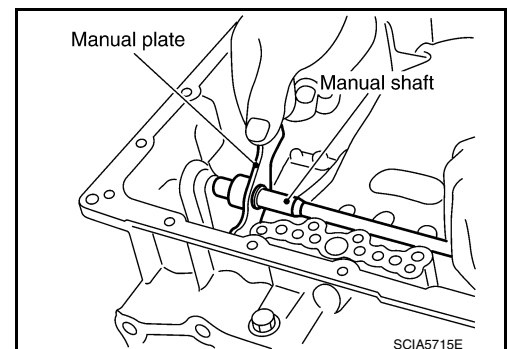

62. Remove parking rod from manual plate.

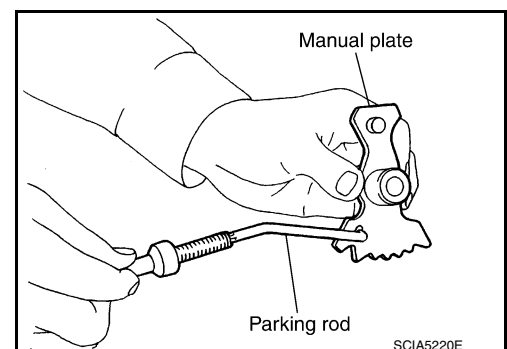

A  
B  
C  
TM  
E  
F  
G  
H  
I  
J  
K  
L  
M  
N  
O  
P

# DISASSEMBLY

## < UNIT DISASSEMBLY AND ASSEMBLY >

63. Remove manual shaft from transmission case.

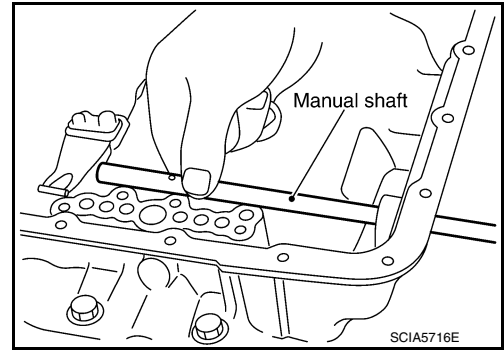

64. Remove manual shaft oil seals using suitable tool.

**CAUTION:**

**Do not scratch transmission case.**

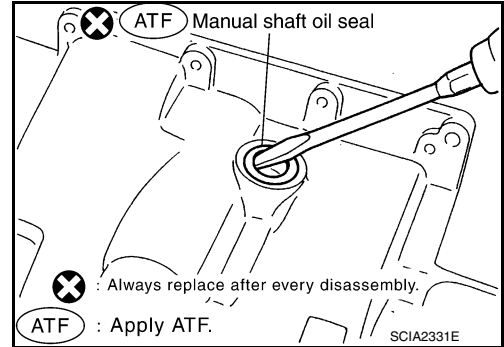

65. Remove detent spring and spacer from transmission case.

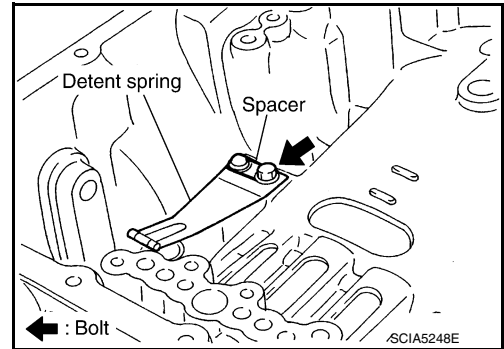

66. Remove snap ring from transmission case using suitable tool.

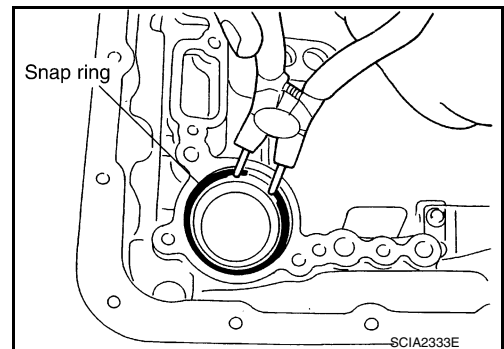

67. Remove servo assembly (with return spring) from transmission case.

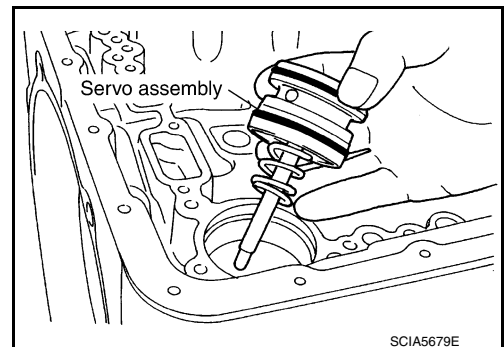

# DISASSEMBLY

## < UNIT DISASSEMBLY AND ASSEMBLY >

68. Remove return spring from servo assembly.

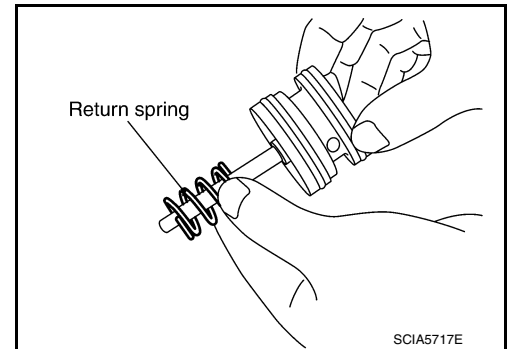

69. Remove O-rings from servo assembly.

**CAUTION:**  
Do not reuse O-rings.

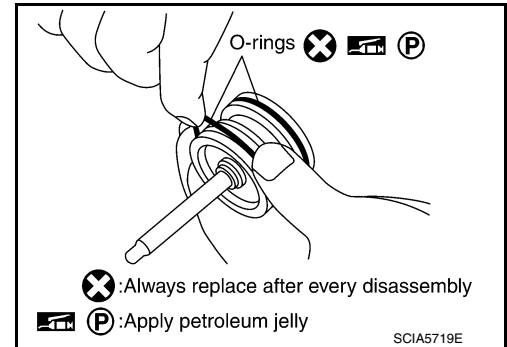

70. Remove needle bearing (1) from rear extension (2WD models) or adapter case (4WD models).

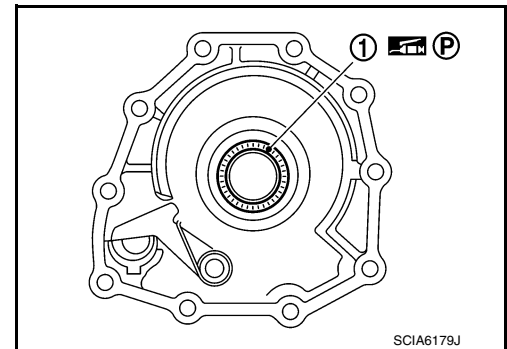

71. Remove parking actuator support from rear extension (2WD models) or adapter case (4WD models).

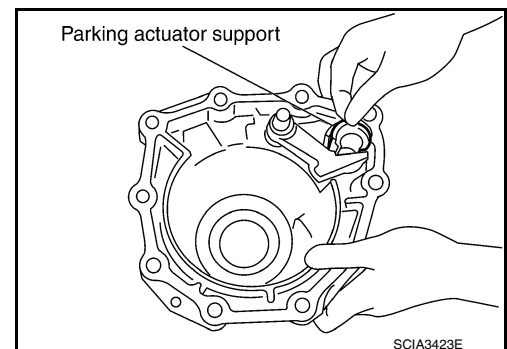

72. Remove parking pawl (with return spring) and pawl shaft from rear extension (2WD models) or adapter case (4WD models).

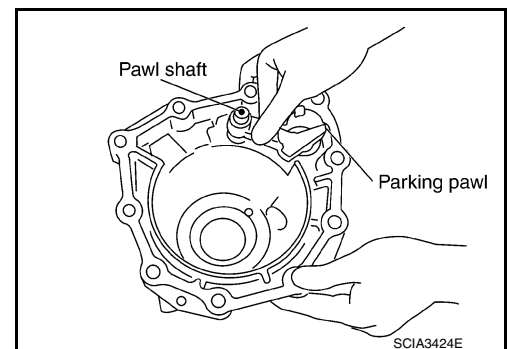

A  
B  
C  
TM  
E  
F  
G  
H  
I  
J  
K  
L  
M  
N  
O  
P

## DISASSEMBLY

### < UNIT DISASSEMBLY AND ASSEMBLY >

73. Remove return spring (1) from parking pawl (2).

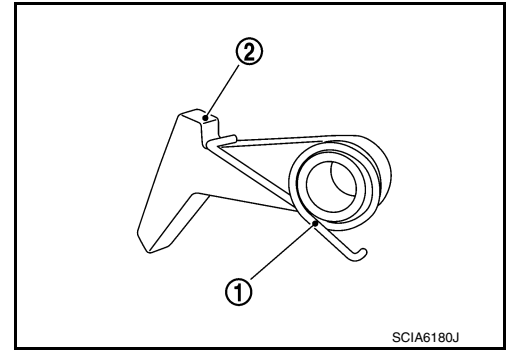

74. Remove rear oil seal from rear extension (2WD models) or adapter case (4WD models) using suitable tool.

**CAUTION:**

**Do not scratch rear extension (2WD models) or adapter case (4WD models).**

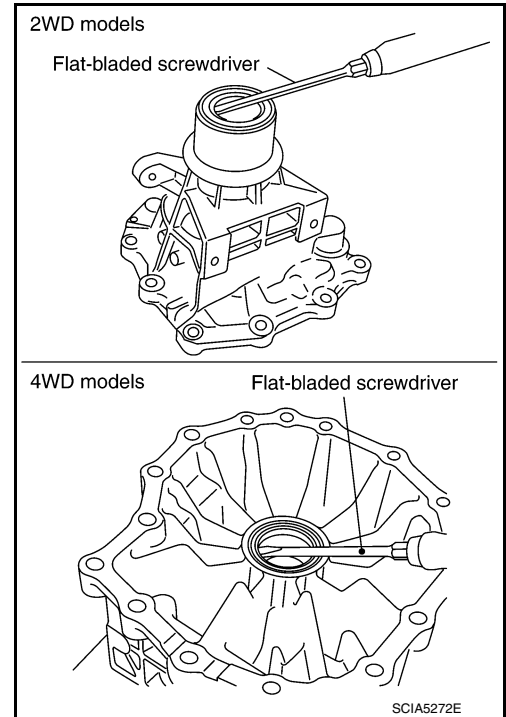

# REPAIR FOR COMPONENT PARTS

< UNIT DISASSEMBLY AND ASSEMBLY >

## REPAIR FOR COMPONENT PARTS

### Oil Pump

INFOID:000000009885929

#### COMPONENTS

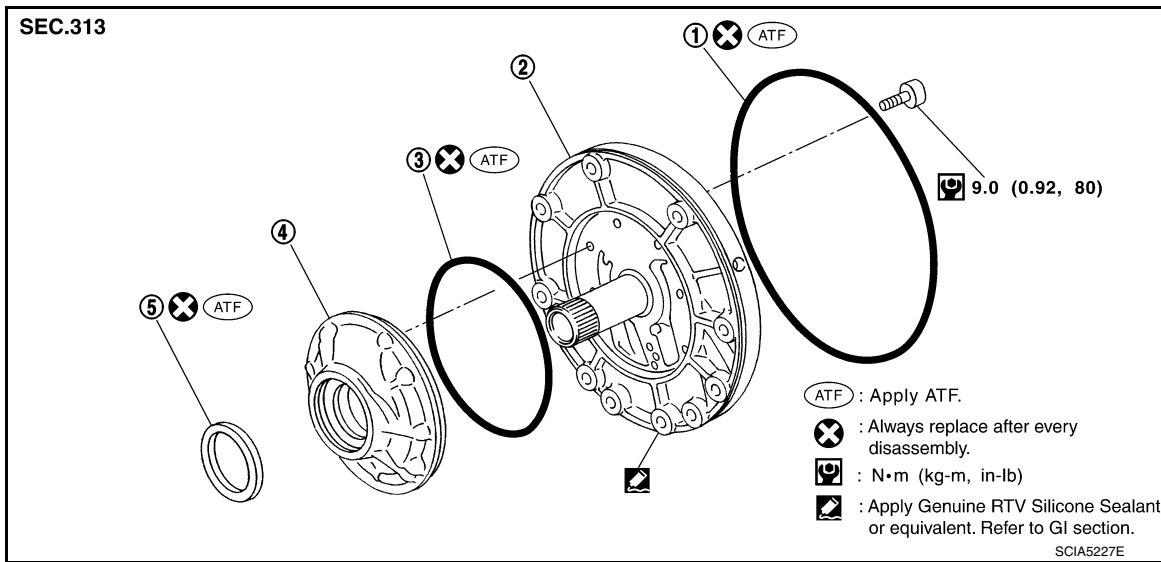

- |                     |                              |           |
|---------------------|------------------------------|-----------|
| 1. O-ring           | 2. Oil pump cover            | 3. O-ring |
| 4. Oil pump housing | 5. Oil pump housing oil seal |           |

#### DISASSEMBLY

- Remove oil pump housing from oil pump cover.

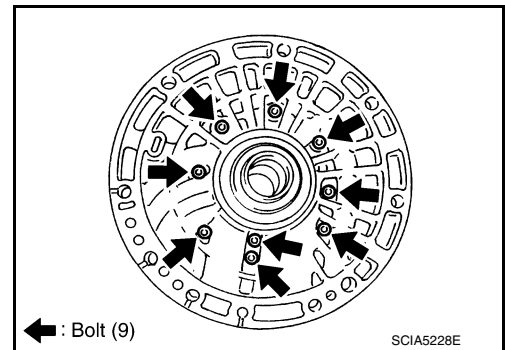

- Remove oil pump housing oil seal using suitable tool.

**CAUTION:**  
Be careful not to scratch oil pump housing.

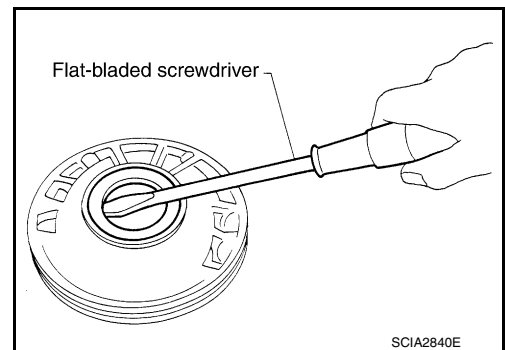

A  
B  
C  
TM  
E  
F  
G  
H  
I  
J  
K  
L  
M  
N  
O  
P

# REPAIR FOR COMPONENT PARTS

## < UNIT DISASSEMBLY AND ASSEMBLY >

3. Remove O-ring from oil pump housing.

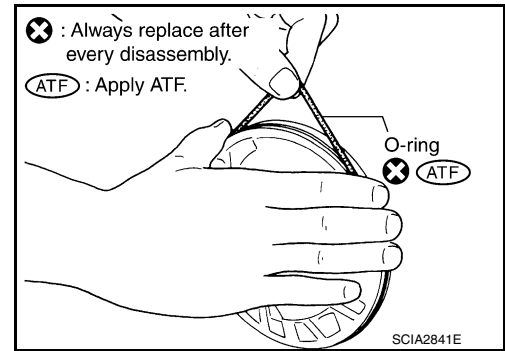

4. Remove O-ring from oil pump cover.

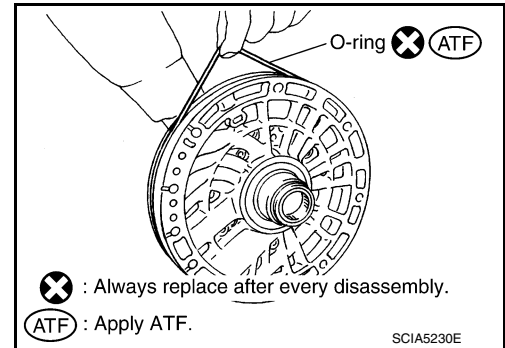

## ASSEMBLY

1. Install new O-ring to oil pump cover.

**CAUTION:**

- Do not reuse O-ring.
- Apply ATF to O-ring.

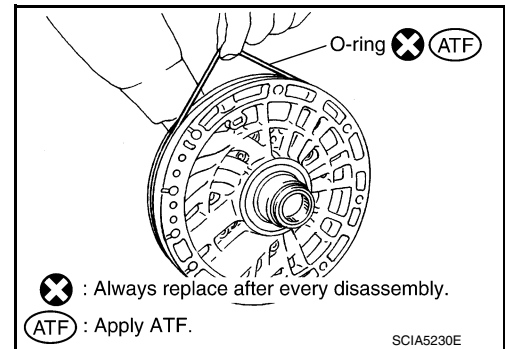

2. Install new O-ring to oil pump housing.

**CAUTION:**

- Do not reuse O-ring.
- Apply ATF to O-ring.

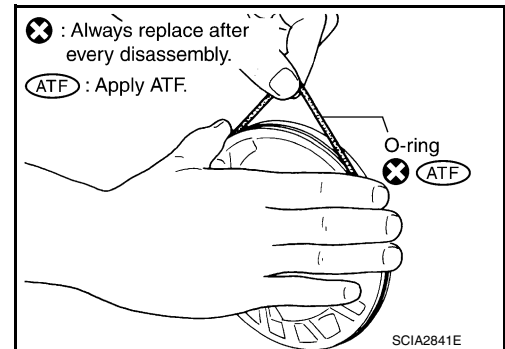



# REPAIR FOR COMPONENT PARTS

## < UNIT DISASSEMBLY AND ASSEMBLY >

3. Install new oil pump housing oil seal to the oil pump housing using Tool.

**CAUTION:**

- Do not reuse oil seal.
- Apply ATF to oil seal.

Tool number : ST33400001 (J-26082)

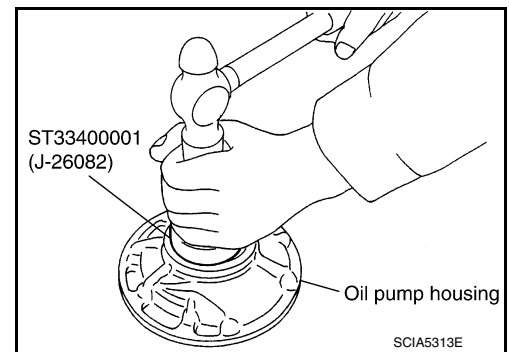

4. Install oil pump housing in oil pump cover. Tighten oil pump housing bolts to the specified torque. Refer to [TM-217, "Component"](#).

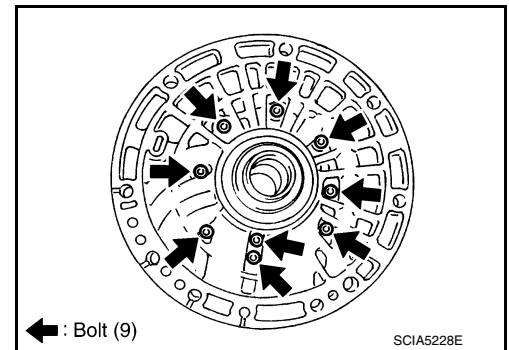

## Front Sun Gear, 3rd One-Way Clutch

INFOID:000000009885930

### COMPONENTS

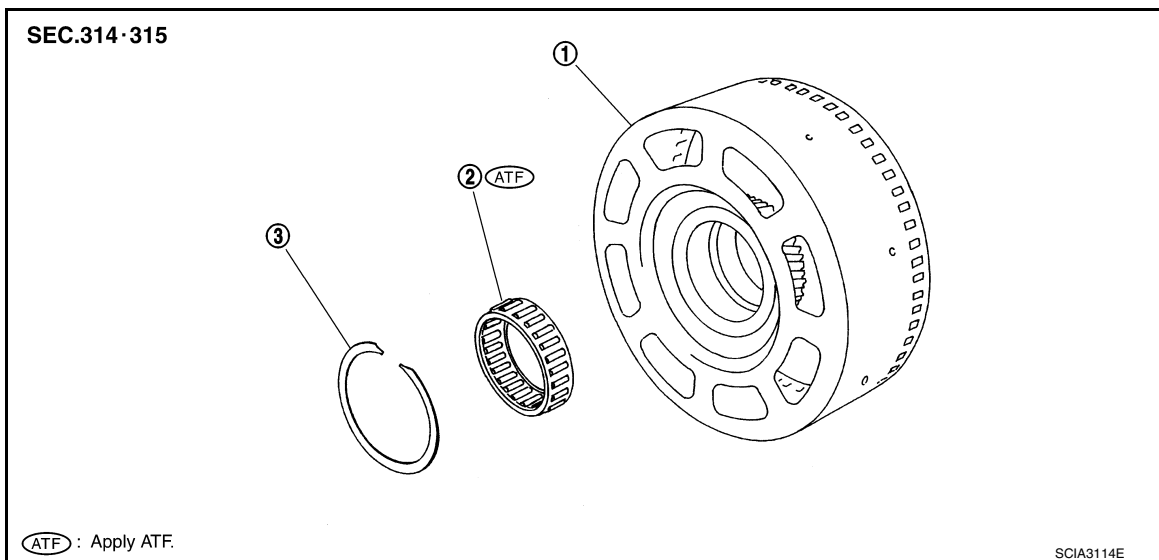

1. Front sun gear

2. 3rd one-way clutch

3. Snap ring

### DISASSEMBLY

# REPAIR FOR COMPONENT PARTS

## < UNIT DISASSEMBLY AND ASSEMBLY >

1. Remove snap ring from front sun gear using suitable tool.

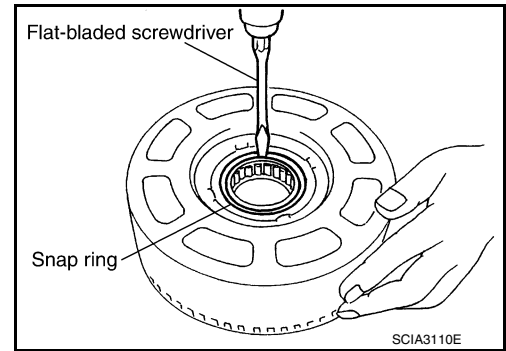

2. Remove 3rd one-way clutch from front sun gear.

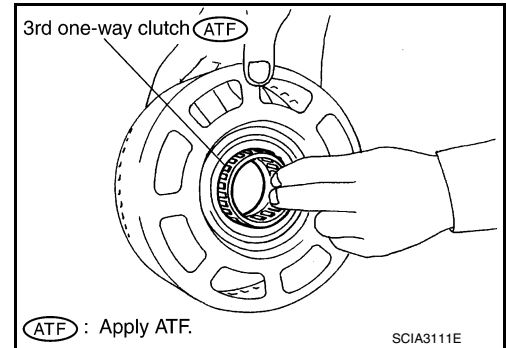

## INSPECTION

### 3rd One-way Clutch

- Check frictional surface for wear or damage.

**CAUTION:**

**If necessary, replace the 3rd one-way clutch.**

### Front Sun Gear Snap Ring

- Check for deformation, fatigue or damage.

**CAUTION:**

**If necessary, replace the snap ring.**

### Front Sun Gear

- Check for deformation, fatigue or damage.

**CAUTION:**

**If necessary, replace the front sun gear.**

## ASSEMBLY

1. Install 3rd one-way clutch in front sun gear.

**CAUTION:**

**Apply ATF to 3rd one-way clutch.**

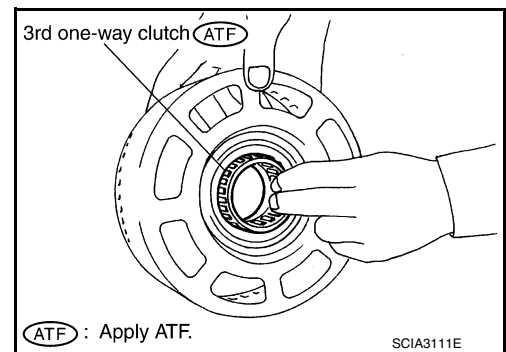

## REPAIR FOR COMPONENT PARTS

### < UNIT DISASSEMBLY AND ASSEMBLY >

2. Install snap ring in front sun gear using suitable tool.

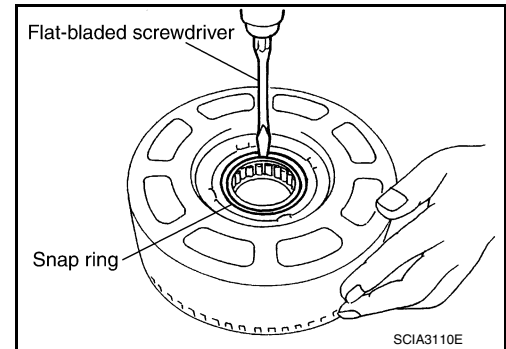

3. Check operation of 3rd one-way clutch.
  - a. Hold oil pump assembly and turn front sun gear.
  - b. Check 3rd one-way clutch for correct locking and unlocking directions.

**CAUTION:**

**If not as shown, check installation direction of 3rd one-way clutch.**

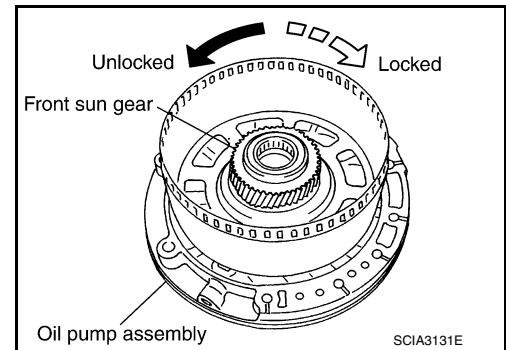

Front Carrier, Input Clutch, Rear Internal Gear

COMPONENTS

INFOID:000000009885931

# REPAIR FOR COMPONENT PARTS

< UNIT DISASSEMBLY AND ASSEMBLY >

SEC.314·315

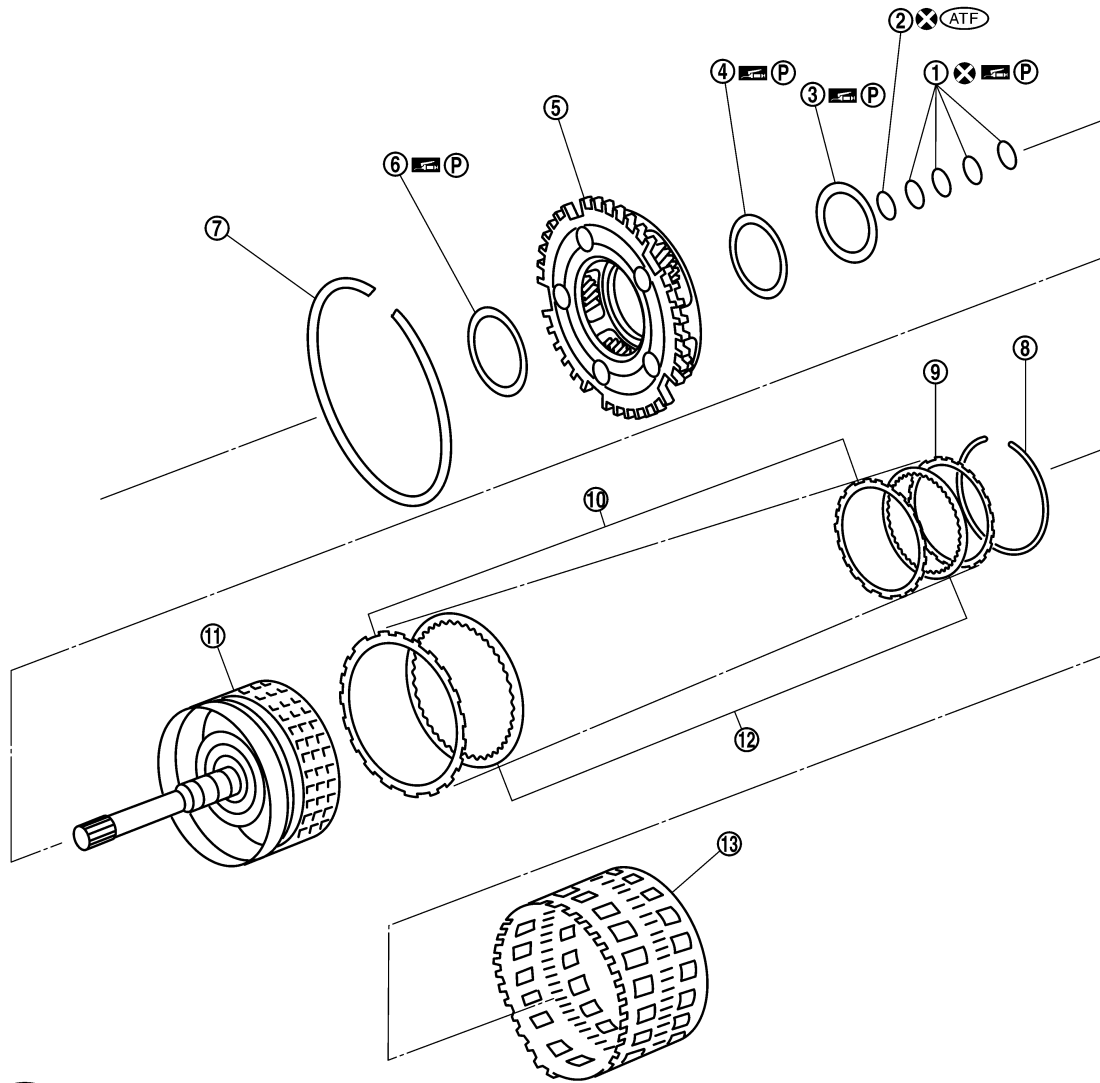

(ATF) : Apply ATF

(P) : Apply petroleum jelly.

(X) : Always replace after every disassembly.

SCIA5244E

- |                        |                           |                    |
|------------------------|---------------------------|--------------------|
| 1. Seal ring           | 2. O-ring                 | 3. Needle bearing  |
| 4. Bearing race        | 5. Front carrier assembly | 6. Needle bearing  |
| 7. Snap ring           | 8. Snap ring              | 9. Retaining plate |
| 10. Driven plate       | 11. Input clutch drum     | 12. Drive plate    |
| 13. Rear internal gear |                           |                    |

## DISASSEMBLY

# REPAIR FOR COMPONENT PARTS

## < UNIT DISASSEMBLY AND ASSEMBLY >

1. Compress snap ring using suitable tool.
2. Remove front carrier assembly and input clutch assembly from rear internal gear.
3. Remove front carrier assembly from input clutch assembly.

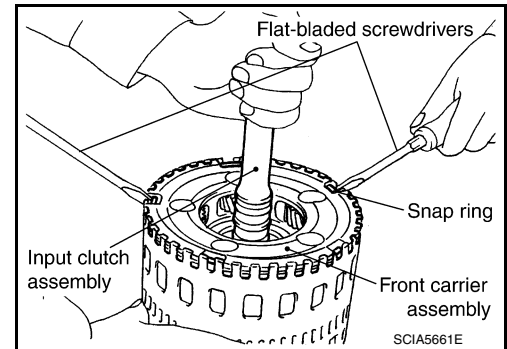

- a. Remove bearing race from front carrier assembly.

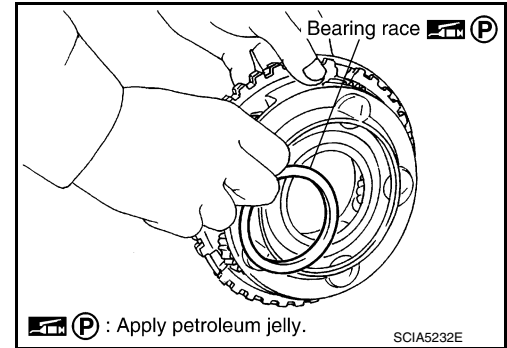

- b. Remove needle bearing from front carrier assembly.

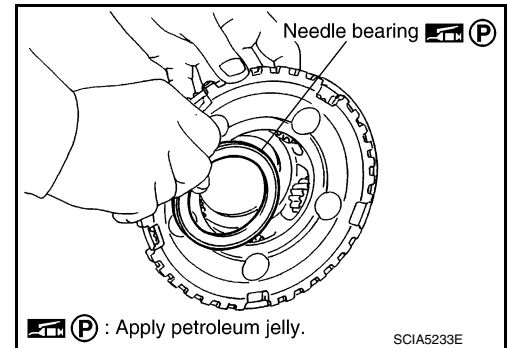

- c. Remove snap ring from front carrier assembly.  
**CAUTION:**  
Do not expand snap ring excessively.

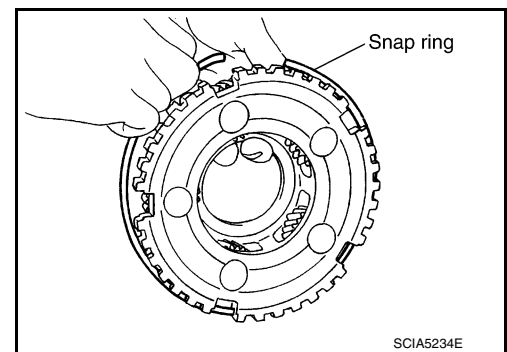

4. Disassemble input clutch assembly.
- a. Remove O-ring and seal rings from input clutch assembly.

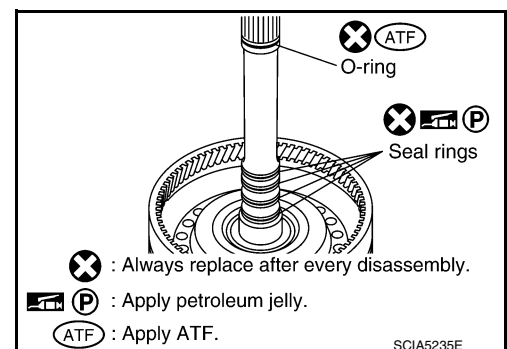

A  
B  
C  
TM  
E  
F  
G  
H  
I  
J  
K  
L  
M  
N  
O  
P

# REPAIR FOR COMPONENT PARTS

## < UNIT DISASSEMBLY AND ASSEMBLY >

b. Remove needle bearing from input clutch assembly.

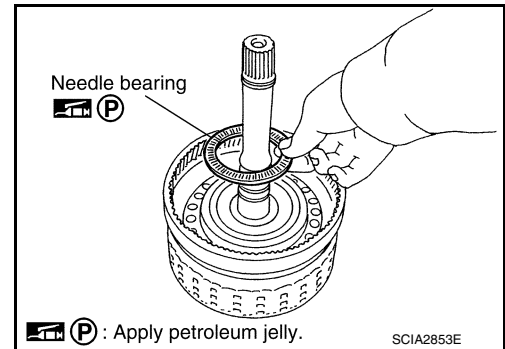

c. Remove snap ring from input clutch drum using suitable tool.

d. Remove drive plates, driven plates and retaining plate from input clutch drum.

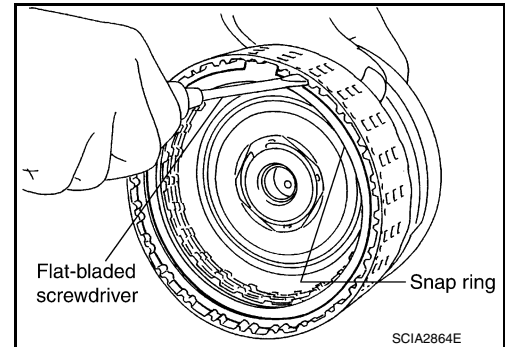

## INSPECTION

### Front Carrier Snap Ring

- Check for deformation, fatigue or damage.

**CAUTION:**

**If necessary, replace the snap ring.**

### Input Clutch Snap Ring

- Check for deformation, fatigue or damage.

**CAUTION:**

**If necessary, replace the input clutch assembly.**

### Input Clutch Drum

- Check for deformation, fatigue or damage or burns.

**CAUTION:**

**If necessary, replace the input clutch assembly.**

### Input Clutch Drive Plates

- Check facing for burns, cracks or damage.

**CAUTION:**

**If necessary, replace the input clutch assembly.**

### Input Clutch Retaining Plate and Driven Plates

- Check facing for burns, cracks or damage.

**CAUTION:**

**If necessary, replace the input clutch assembly.**

### Front Carrier Assembly

- Check for deformation, fatigue or damage.

**CAUTION:**

**If necessary, replace the front carrier assembly.**

### Rear Internal Gear

- Check for deformation, fatigue or damage.

**CAUTION:**

**If necessary, replace the rear internal gear.**

## ASSEMBLY

1. Install input clutch.

# REPAIR FOR COMPONENT PARTS

## < UNIT DISASSEMBLY AND ASSEMBLY >

- a. Install drive plates, driven plates and retaining plate in input clutch drum.

**CAUTION:**

Take care with order of plates.

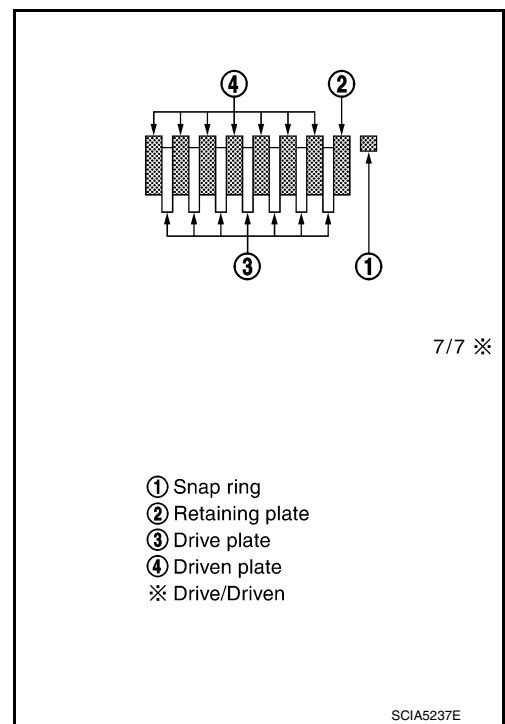

- b. Install snap ring in input clutch drum using suitable tool.

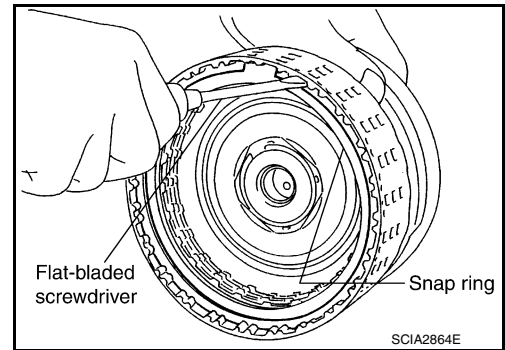

- c. Install needle bearing in input clutch assembly.

**CAUTION:**

Apply petroleum jelly to needle bearing.

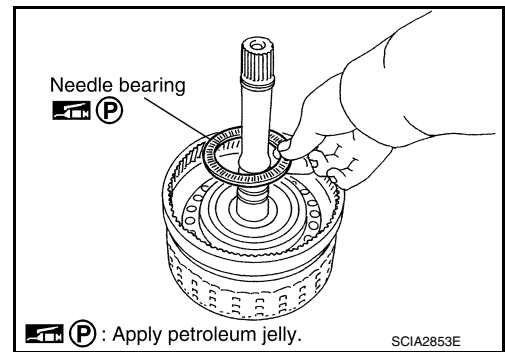

- d. Install new O-ring and new seal rings in input clutch assembly.

**CAUTION:**

- Do not reuse O-ring and seal rings.
- Apply ATF to O-ring.
- Apply petroleum jelly to seal rings.

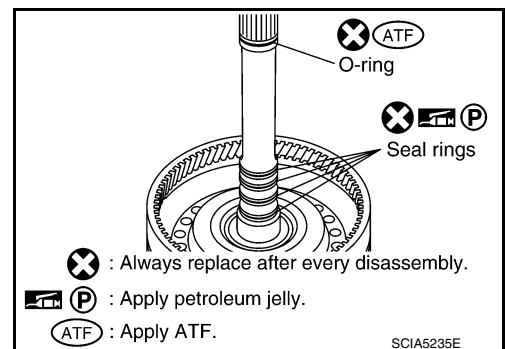

## REPAIR FOR COMPONENT PARTS

### < UNIT DISASSEMBLY AND ASSEMBLY >

2. Install front carrier assembly.
  - a. Install snap ring to front carrier assembly.  
**CAUTION:**  
Do not expand snap ring excessively.

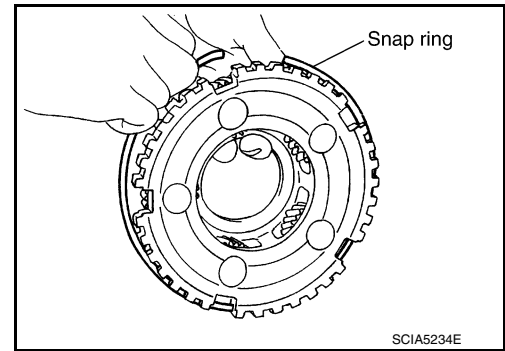

- b. Install needle bearing in front carrier assembly.  
**CAUTION:**
      - Take care with the direction of needle bearing. Refer to [TM-226, "Location of Adjusting Shims, Needle Bearings, Thrust Washers and Snap Rings"](#).
      - Apply petroleum jelly to needle bearing.

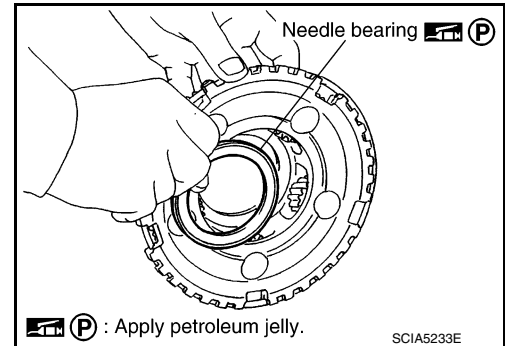

- c. Install bearing race in front carrier assembly.  
**CAUTION:**  
Apply petroleum jelly to bearing race.
      - d. Install front carrier assembly to input clutch assembly.

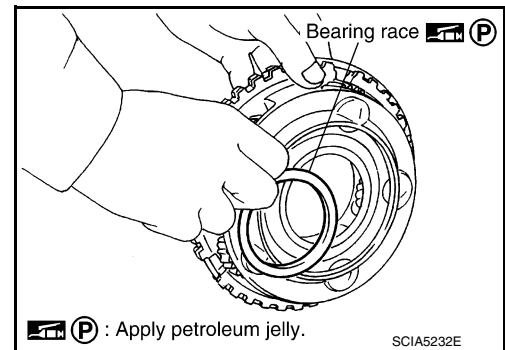

3. Compress snap ring using suitable tool.
4. Install front carrier assembly and input clutch assembly to rear internal gear.

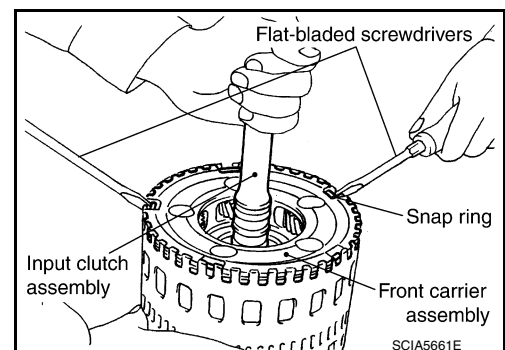

### Mid Sun Gear, Rear Sun Gear, High and Low Reverse Clutch Hub

INFOID:000000009885932

### COMPONENTS



# REPAIR FOR COMPONENT PARTS

< UNIT DISASSEMBLY AND ASSEMBLY >

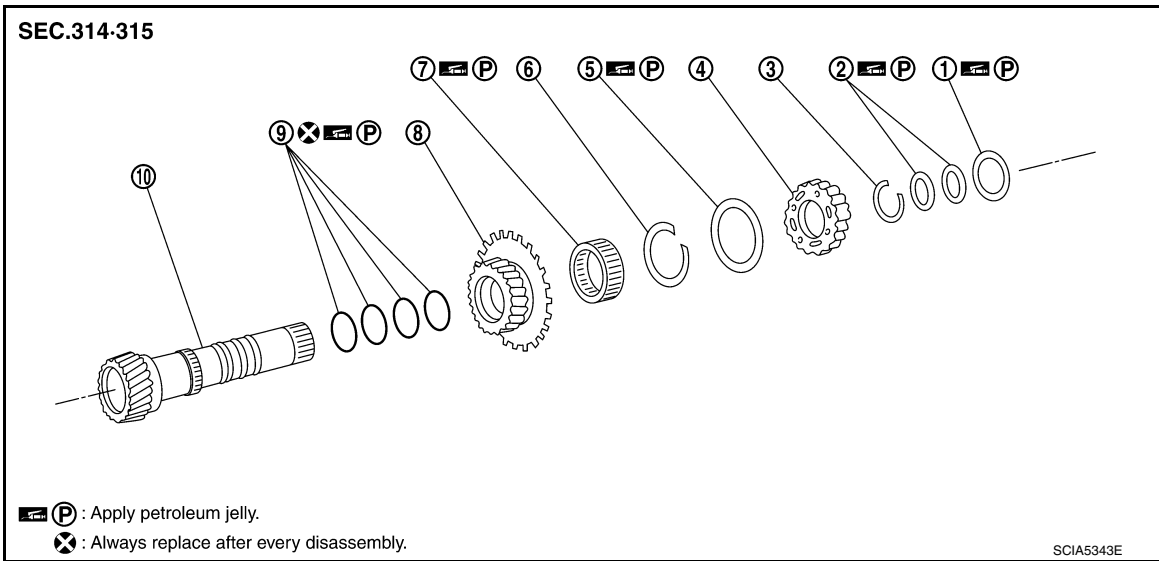

- |                                    |                   |              |
|------------------------------------|-------------------|--------------|
| 1. Needle bearing                  | 2. Bearing race   | 3. Snap ring |
| 4. High and low reverse clutch hub | 5. Needle bearing | 6. Snap ring |
| 7. 1st one-way clutch              | 8. Rear sun gear  | 9. Seal ring |
| 10. Mid sun gear                   |                   |              |

## DISASSEMBLY

- Remove needle bearing and bearing races from high and low reverse clutch hub.

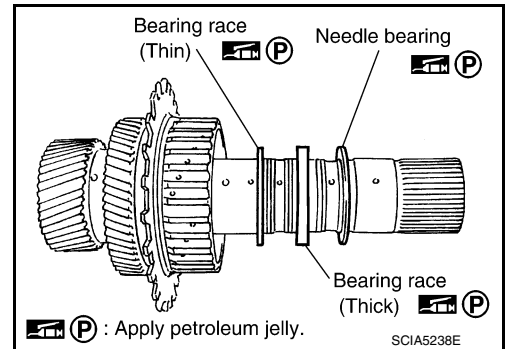

- Remove snap ring from mid sun gear assembly using suitable tool.

**CAUTION:**  
 Do not expand snap ring excessively.

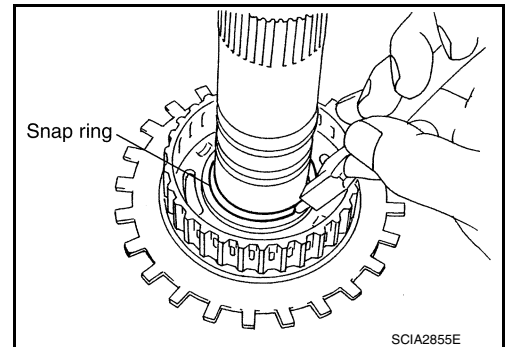

A  
B  
C  
TM  
E  
F  
G  
H  
I  
J  
K  
L  
M  
N  
O  
P

## REPAIR FOR COMPONENT PARTS

### < UNIT DISASSEMBLY AND ASSEMBLY >

3. Remove high and low reverse clutch hub from mid sun gear assembly.

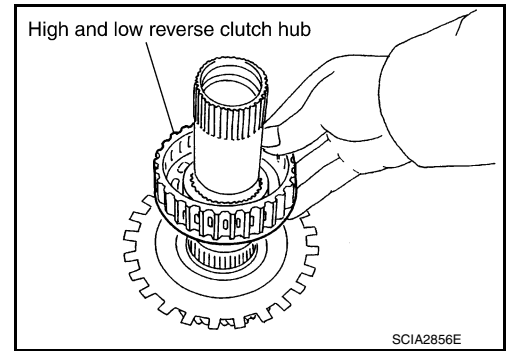

- a. Remove needle bearing from high and low reverse clutch hub.

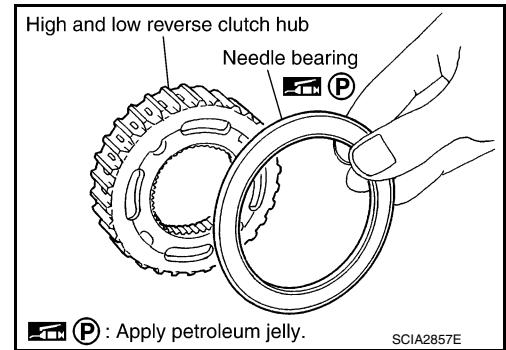

4. Remove rear sun gear assembly from mid sun gear assembly.

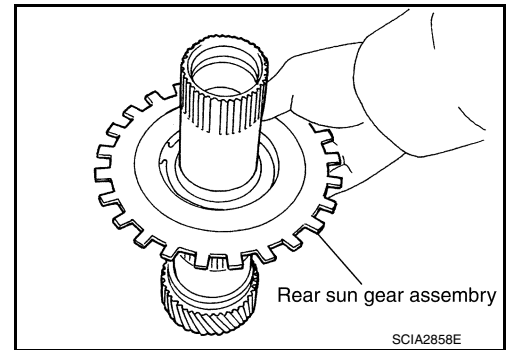

- a. Remove snap ring from rear sun gear using suitable tool.

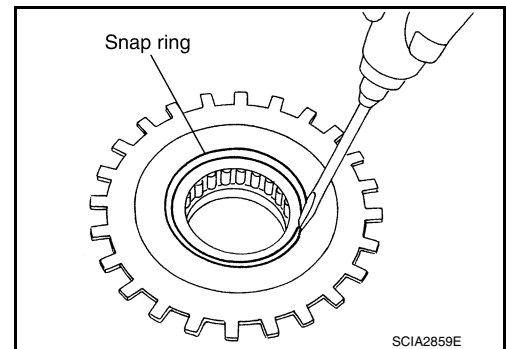

# REPAIR FOR COMPONENT PARTS

## < UNIT DISASSEMBLY AND ASSEMBLY >

- b. Remove 1st one-way clutch from rear sun gear.

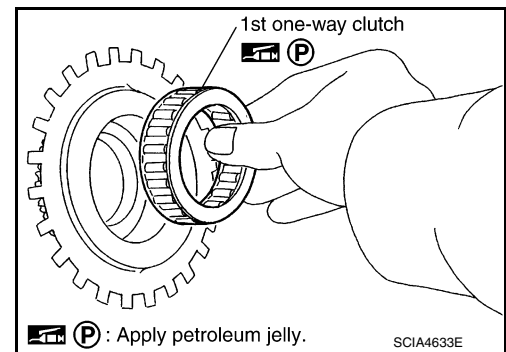

5. Remove seal rings from mid sun gear.

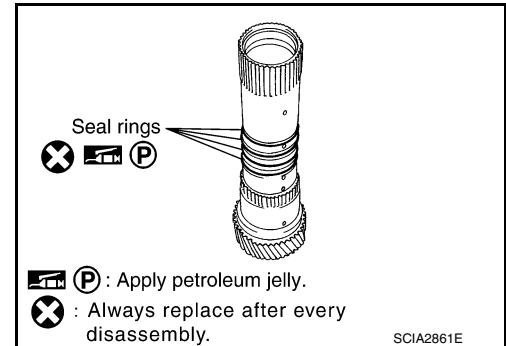

## INSPECTION

High and Low Reverse Clutch Hub Snap Ring, Rear Sun Gear Snap Ring

- Check for deformation, fatigue or damage.

**CAUTION:**

**If necessary, replace the snap ring.**

1st One-way Clutch

- Check frictional surface for wear or damage.

**CAUTION:**

**If necessary, replace the 1st one-way clutch.**

Mid Sun Gear

- Check for deformation, fatigue or damage.

**CAUTION:**

**If necessary, replace the mid sun gear.**

Rear Sun Gear

- Check for deformation, fatigue or damage.

**CAUTION:**

**If necessary, replace the rear sun gear.**

High and Low Reverse Clutch Hub

- Check for deformation, fatigue or damage.

**CAUTION:**

**If necessary, replace the high and low reverse clutch hub.**

## ASSEMBLY

A  
B  
C  
TM  
E  
F  
G  
H  
I  
J  
K  
L  
M  
N  
O  
P

## REPAIR FOR COMPONENT PARTS

### < UNIT DISASSEMBLY AND ASSEMBLY >

1. Install new seal rings to mid sun gear.

**CAUTION:**

- Do not reuse seal rings.
- Apply petroleum jelly to seal rings.

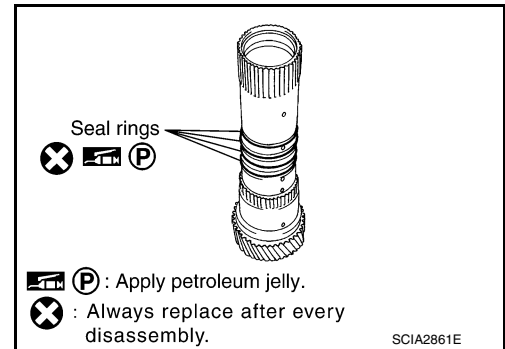

2. Install 1st one-way clutch to rear sun gear.

**CAUTION:**

- Apply petroleum jelly to 1st one-way clutch.

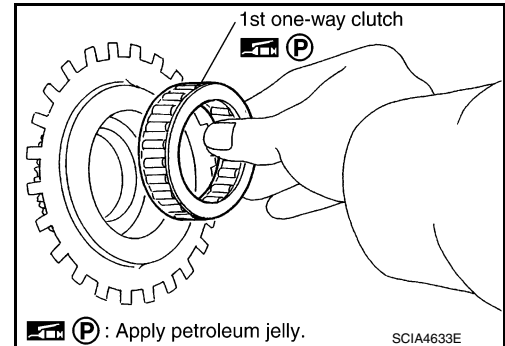

3. Install snap ring to rear sun gear using suitable tool.

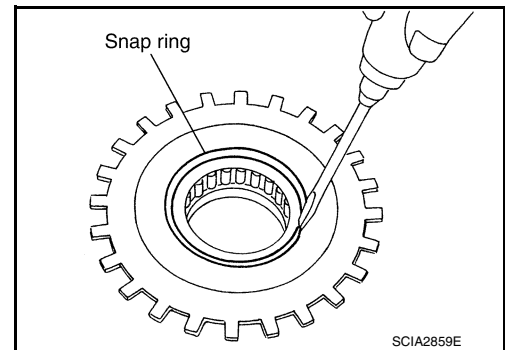

4. Install rear sun gear assembly to mid sun gear assembly.

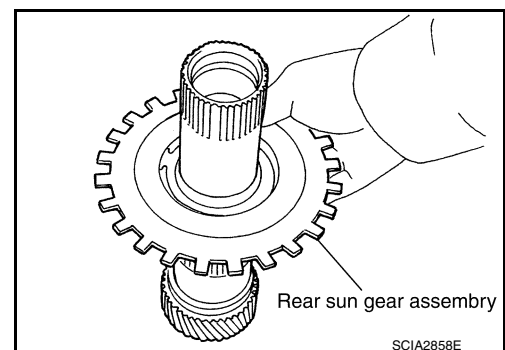

5. Install needle bearing to high and low reverse clutch hub.

**CAUTION:**

- Take care with the direction of needle bearing. Refer to [TM-226, "Location of Adjusting Shims, Needle Bearings, Thrust Washers and Snap Rings"](#).
- Apply petroleum jelly to needle bearing.

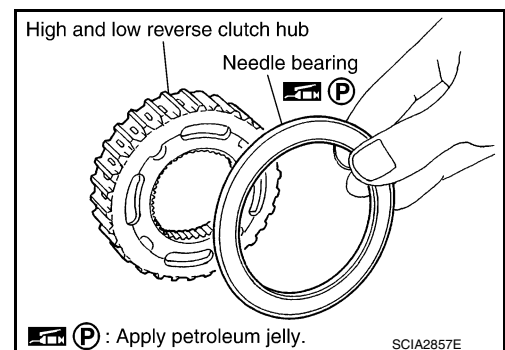

# REPAIR FOR COMPONENT PARTS

## < UNIT DISASSEMBLY AND ASSEMBLY >

6. Install high and low reverse clutch hub to mid sun gear assembly.

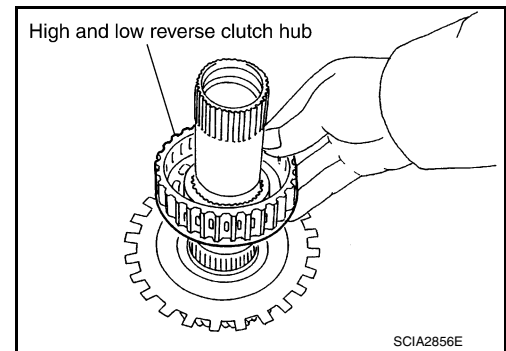

7. Install snap ring to mid sun gear assembly using suitable tool.  
**CAUTION:**  
Do not expand snap ring excessively.

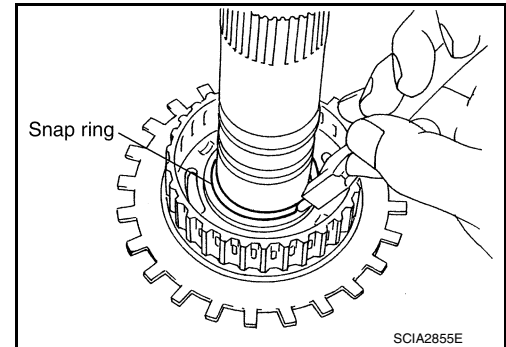

8. Check operation of 1st one-way clutch.  
a. Hold mid sun gear and turn rear sun gear.  
b. Check 1st one-way clutch for correct locking and unlocking directions.  
**CAUTION:**  
If not as shown, check installation direction of 1st one-way clutch.

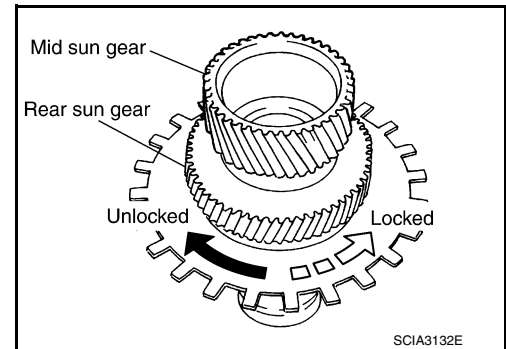

9. Install needle bearing and bearing races to high and low reverse clutch hub.  
**CAUTION:**  
• Apply petroleum jelly to needle bearing and bearing races.  
• Take care with order of bearing races.

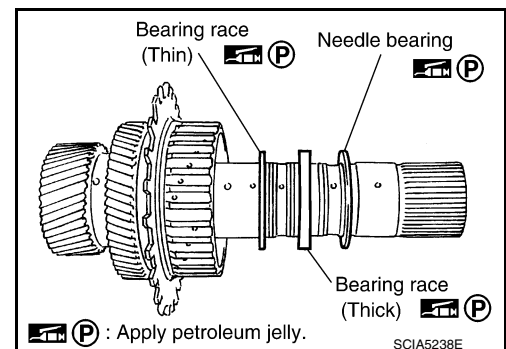

## High and Low Reverse Clutch

### COMPONENTS

INFOID:000000009885933

# REPAIR FOR COMPONENT PARTS

< UNIT DISASSEMBLY AND ASSEMBLY >

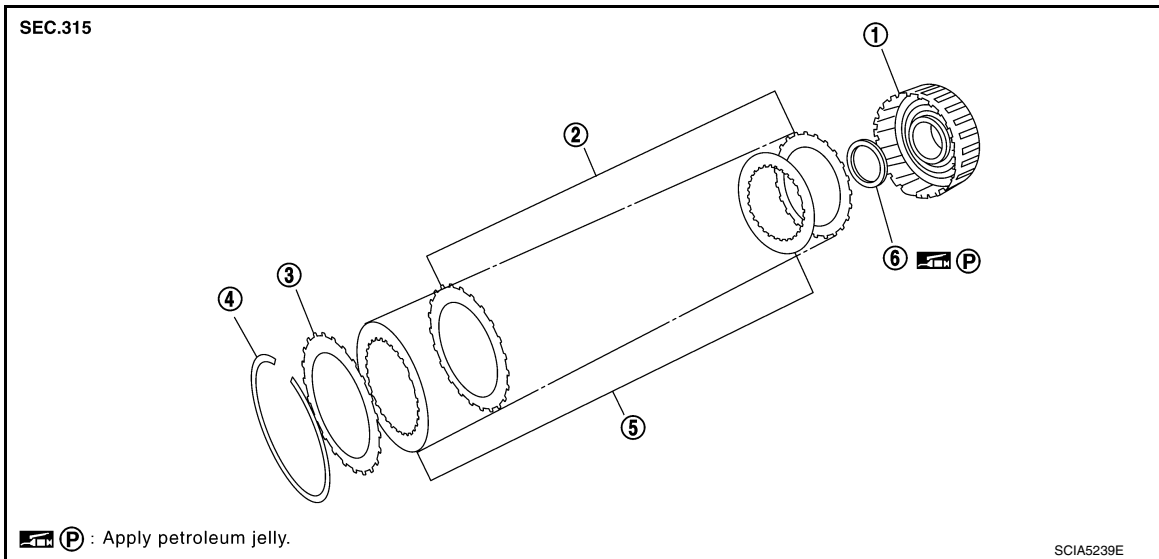

- |                                     |                 |                    |
|-------------------------------------|-----------------|--------------------|
| 1. High and low reverse clutch drum | 2. Driven plate | 3. Retaining plate |
| 4. Snap ring                        | 5. Drive plate  | 6. Bearing race    |

## DISASSEMBLY

1. Remove bearing race from high and low reverse clutch drum.

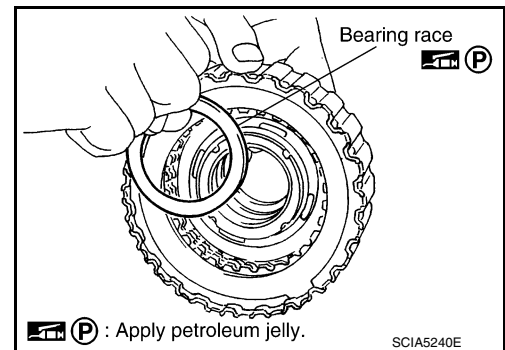

2. Remove snap ring from high and low reverse clutch drum using suitable tool.
3. Remove drive plates, driven plates and retaining plate from high and low reverse clutch drum.

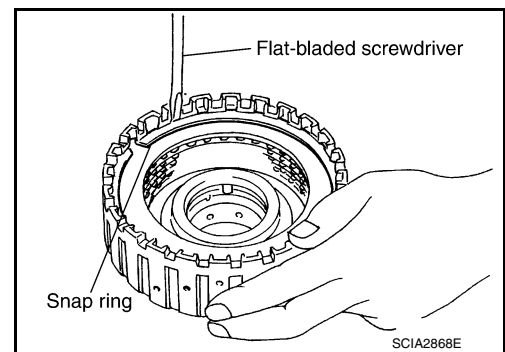

## INSPECTION

- Check the following, and replace high and low reverse clutch assembly if necessary.

High and Low Reverse Clutch Snap Ring

- Check for deformation, fatigue or damage.

High and Low Reverse Clutch Drive Plates

- Check facing for burns, cracks or damage.

High and Low Reverse Clutch Retaining Plate and Driven Plates

- Check facing for burns, cracks or damage.

## ASSEMBLY

# REPAIR FOR COMPONENT PARTS

## < UNIT DISASSEMBLY AND ASSEMBLY >

1. Install drive plates, driven plates and retaining plate in high and low reverse clutch drum.

**CAUTION:**

Take care with the order of plates.

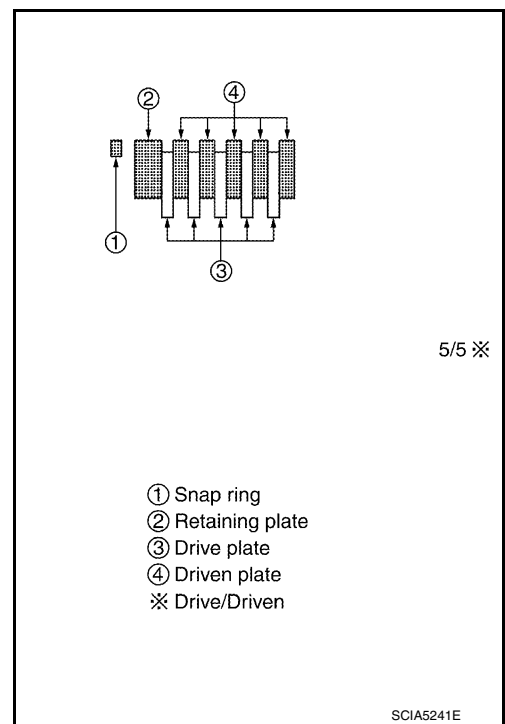

2. Install snap ring in high and low reverse clutch drum using suitable tool.

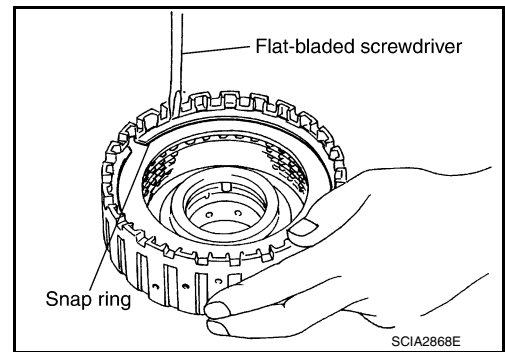

3. Install bearing race to high and low reverse clutch drum.

**CAUTION:**

Apply petroleum jelly to bearing race.

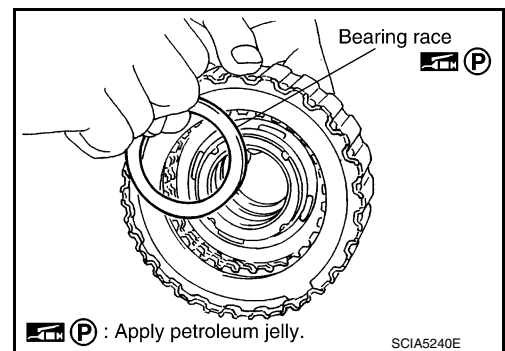

Direct Clutch

COMPONENTS

INFOID:000000009885934

# REPAIR FOR COMPONENT PARTS

< UNIT DISASSEMBLY AND ASSEMBLY >

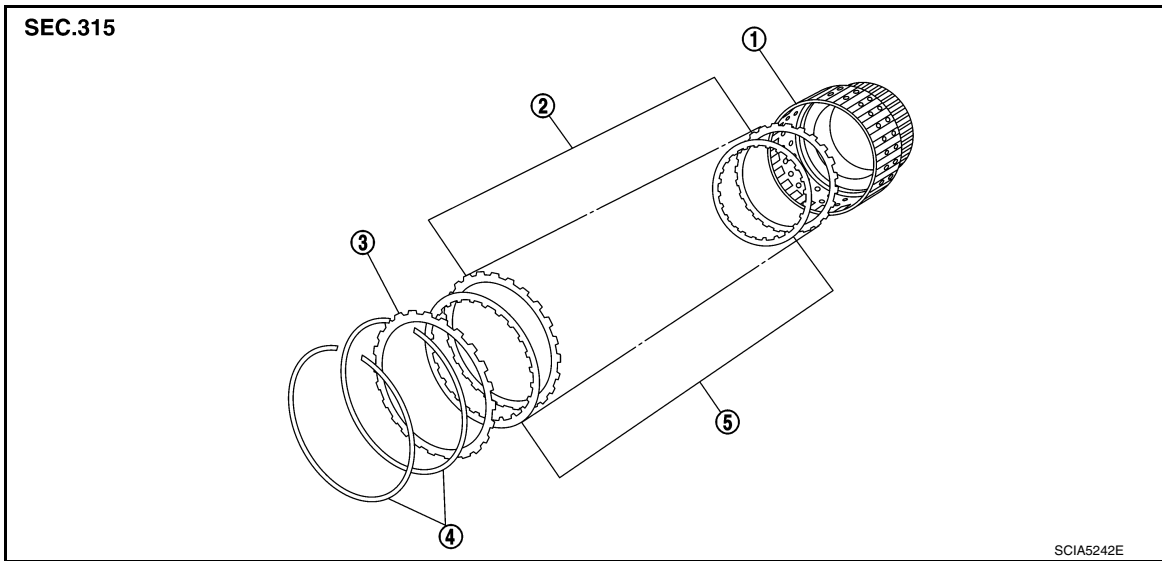

- |                       |                 |                    |
|-----------------------|-----------------|--------------------|
| 1. Direct clutch drum | 2. Driven plate | 3. Retaining plate |
| 4. Snap ring          | 5. Drive plate  |                    |

## DISASSEMBLY

1. Remove snap rings from direct clutch drum using suitable tool.
2. Remove drive plates, driven plates and retaining plate from direct clutch drum.

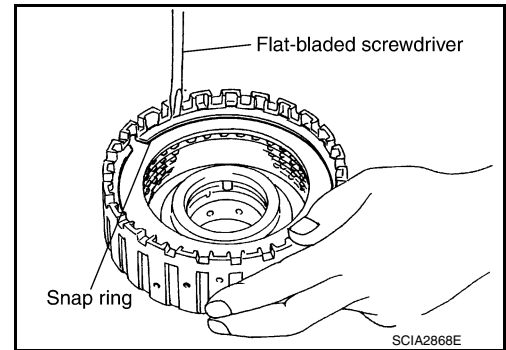

## INSPECTION

- **Check the following, and replace direct clutch assembly if necessary.**

### Direct Clutch Snap Rings

- Check for deformation, fatigue or damage.

### Direct Clutch Drive Plates

- Check facing for burns, cracks or damage.

### Direct Clutch Retaining Plate and Driven Plates

- Check facing for burns, cracks or damage.

## ASSEMBLY



# REPAIR FOR COMPONENT PARTS

## < UNIT DISASSEMBLY AND ASSEMBLY >

1. Install drive plates, driven plates and retaining plate in direct clutch drum.

**CAUTION:**

Take care with the order of plates.

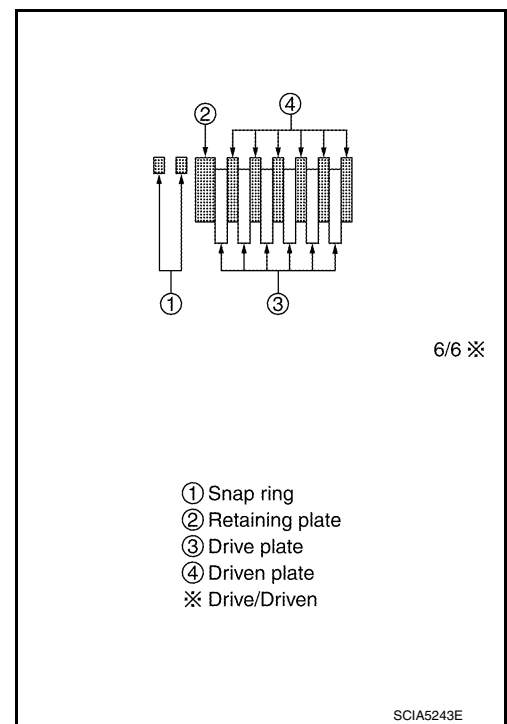

2. Install snap rings in direct clutch drum using suitable tool.

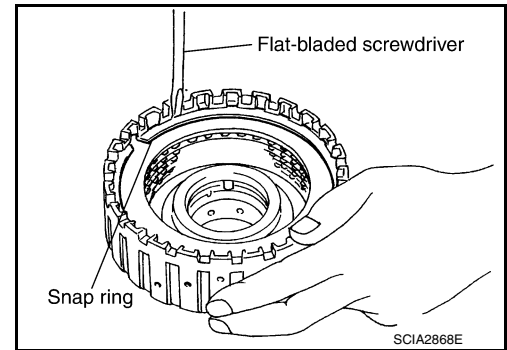

A  
B  
C  
TM  
E  
F  
G  
H  
I  
J  
K  
L  
M  
N  
O  
P

# ASSEMBLY

< UNIT DISASSEMBLY AND ASSEMBLY >

## ASSEMBLY

### Assembly (1)

INFOID:000000009885935

1. Drive manual shaft oil seals into the transmission case until they are flush using suitable tool.

**CAUTION:**

- Apply ATF to manual shaft oil seals.
- Do not reuse manual shaft oil seals.

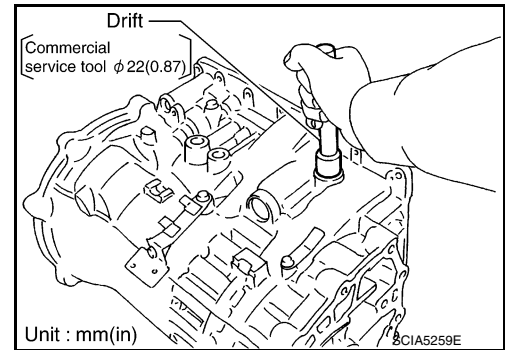

2. Install detent spring and spacer in transmission case and secure with the bolt.

**Bolt : 7.9 N·m (0.81 kg-m, 70 in-lb)**

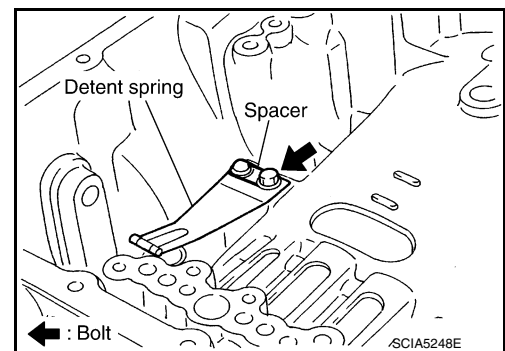

3. Install manual shaft to transmission case.

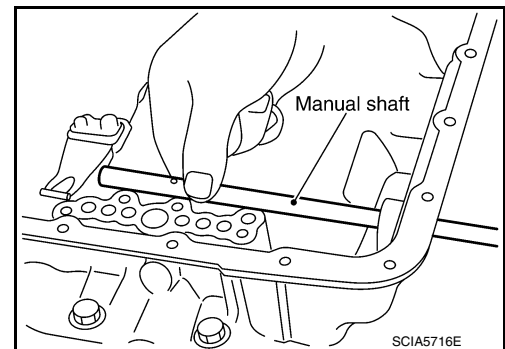

4. Install parking rod to manual plate.

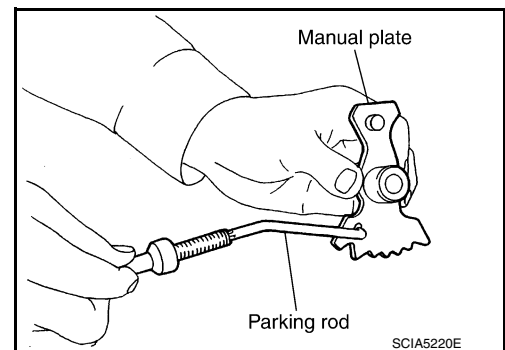

# ASSEMBLY

## < UNIT DISASSEMBLY AND ASSEMBLY >

5. Install manual plate (with parking rod) to manual shaft.

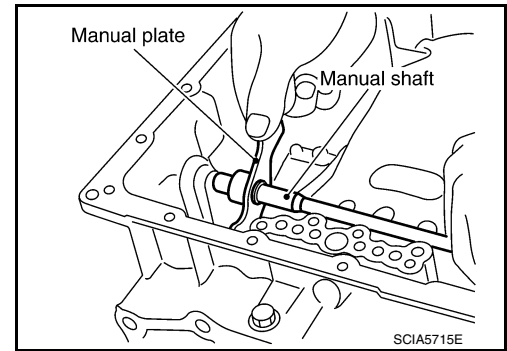

6. Install retaining pin into the manual plate and manual shaft.
- Align pinhole of the manual plate to pinhole of the manual shaft using suitable tool.
  - Tap the retaining pin into the manual plate using suitable tool.
 

**CAUTION:**

    - Drive retaining pin to  $2\pm 0.5$  mm ( $0.08\pm 0.020$  in) over the manual plate.
    - Do not reuse retaining pin.

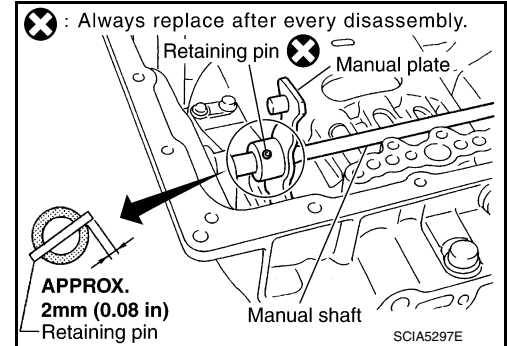

7. Install retaining pin into the transmission case and manual shaft.
- Align pinhole of the transmission case to pinhole of the manual shaft using suitable tool.
  - Tap the retaining pin into the transmission case using suitable tool.
 

**CAUTION:**

    - Drive retaining pin to  $5\pm 1$  mm ( $0.20\pm 0.04$  in) over the transmission case.
    - Do not reuse retaining pin.

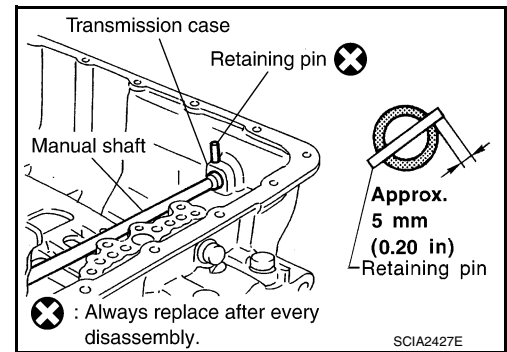

8. Install O-rings to servo assembly.

- CAUTION:**
- Do not reuse O-rings.
  - Apply petroleum jelly to O-rings.

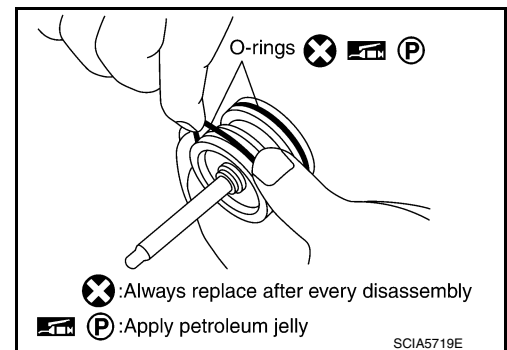

9. Install return spring to servo assembly.

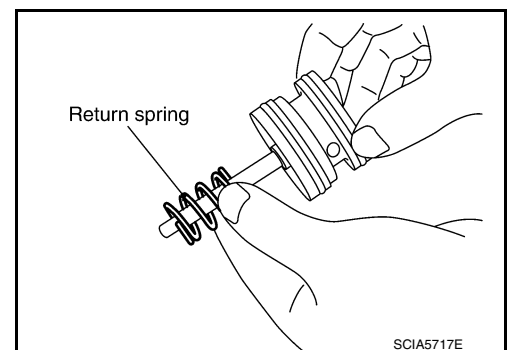

# ASSEMBLY

## < UNIT DISASSEMBLY AND ASSEMBLY >

10. Install servo assembly in transmission case.

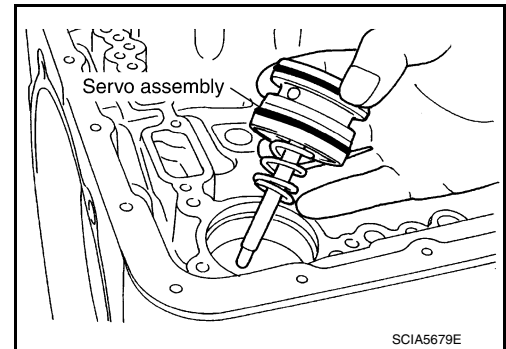

11. Install snap ring to transmission case using suitable tool.

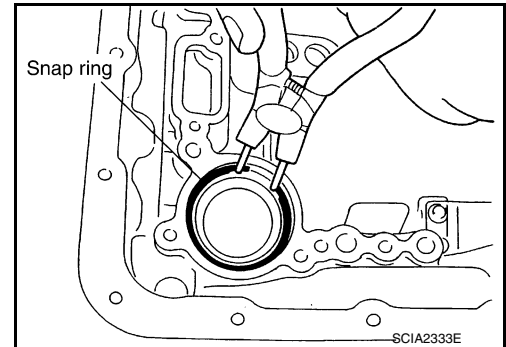

12. Install D-rings in reverse brake piston.

**CAUTION:**

- Do not reuse D-rings.
- Apply ATF to D-rings.

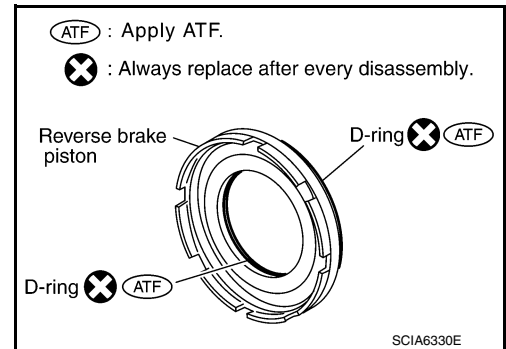

13. Install reverse brake piston in transmission case.

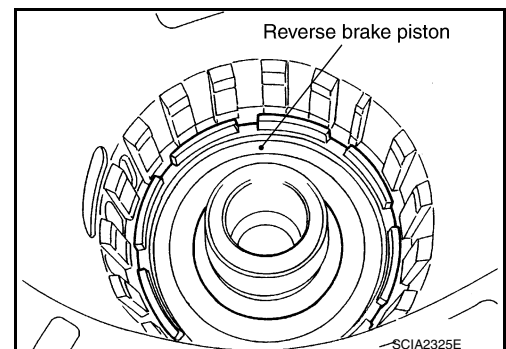

14. Install needle bearing to drum support edge surface.

**CAUTION:**

- Apply petroleum jelly to needle bearing.

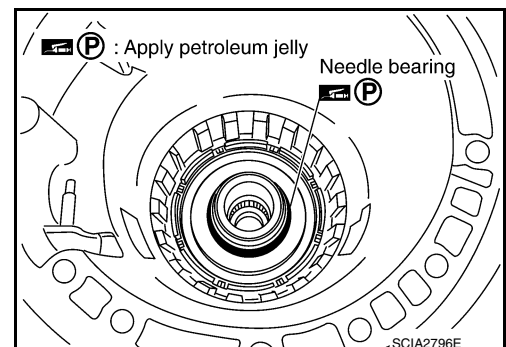

# ASSEMBLY

## < UNIT DISASSEMBLY AND ASSEMBLY >

15. Install seal rings to drum support.

**CAUTION:**

- Do not reuse seal rings.
- Apply petroleum jelly to seal rings.

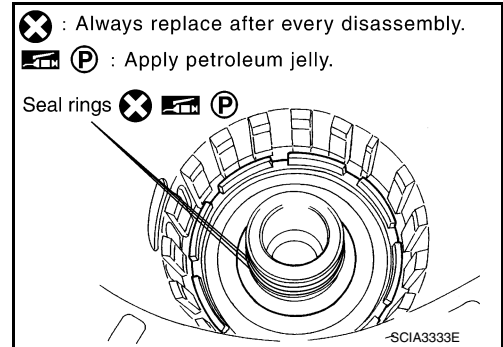

16. Install spring retainer and return spring in transmission case.

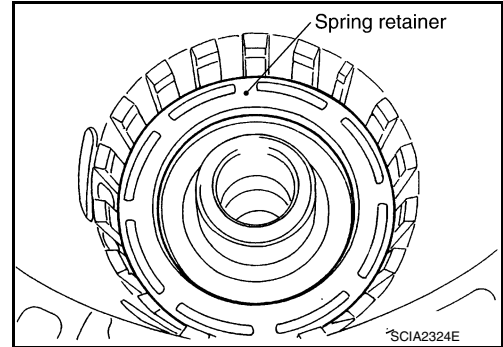

17. Install snap ring in transmission case while compressing return spring using Tool.

**Tool number** : KV31102400 (J-34285 and J-34285-87)

**CAUTION:**

Securely assemble them using a flat-bladed screwdriver so that snap ring tension is slightly weak.

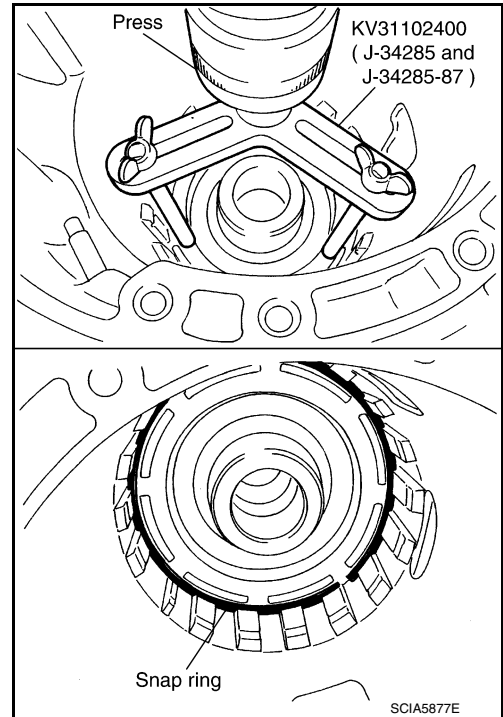

18. Install revers brake drive plates driven plates and dish plates in transmission case.

**CAUTION:**

A  
B  
C  
TM  
E  
F  
G  
H  
I  
J  
K  
L  
M  
N  
O  
P

# ASSEMBLY

## < UNIT DISASSEMBLY AND ASSEMBLY >

### Take care with order of plates.

- Snap ring (1)
- Retaining plate (2)
- Drive plate (3)
- Driven plate (4)
- Dish plate (5)
- Drive plate/Driven plate: 7/7

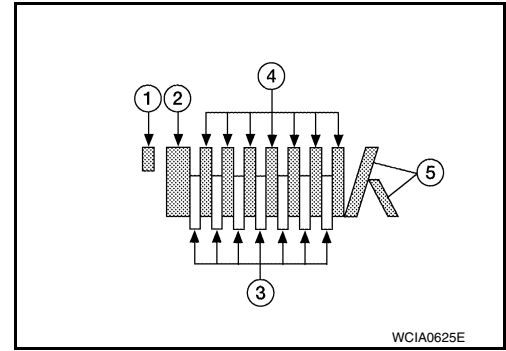

19. Assemble N-spring.

20. Install reverse brake retaining plate in transmission case.

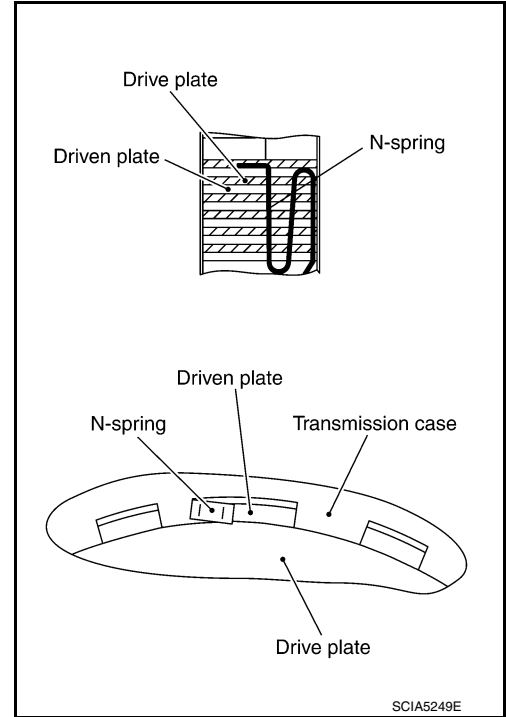

21. Install snap ring in transmission case.

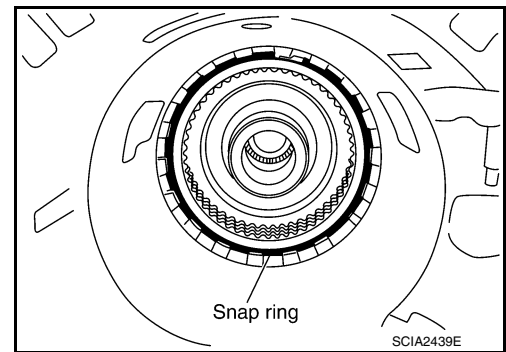

22. Measure clearance (A) between retaining plate and snap ring. If not within specified clearance, select proper retaining plate.

**Clearance (A)** : 0.7 - 1.1mm (0.028 - 0.043 in)  
**Retaining plate** : Refer to [TM-289, "Reverse Brake"](#).

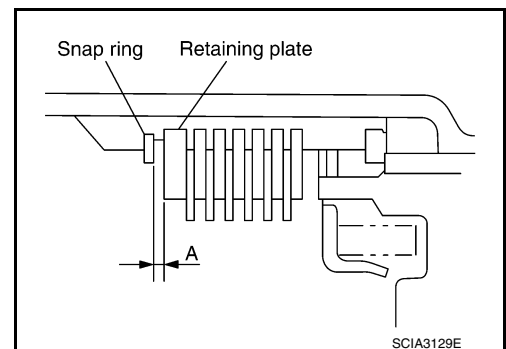

# ASSEMBLY

## < UNIT DISASSEMBLY AND ASSEMBLY >

23. Install needle bearing to transmission case.

**CAUTION:**

- Take care with the direction of needle bearing. Refer to [TM-226, "Location of Adjusting Shims, Needle Bearings, Thrust Washers and Snap Rings"](#).
- Apply petroleum jelly to needle bearing.

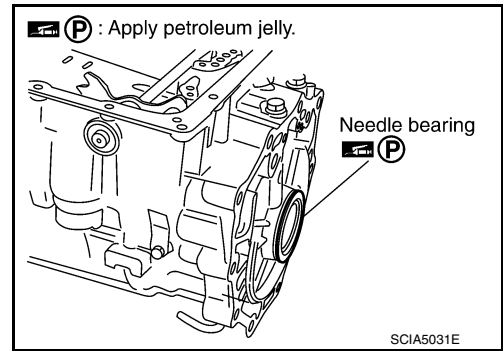

24. Install output speed sensor (1) to transmission case and tighten bolt (←) to specified torque.

**Output speed sensor bolt : 5.8 N·m (0.59 kg-m, 51 in-lb)**

**CAUTION:**

- Do not subject sensor to impact by dropping or hitting it.
- Do not disassemble sensor.
- Do not allow metal filings or any foreign material to get on the sensor's front edge magnetic area.
- Do not place sensor in an area affected by magnetism.

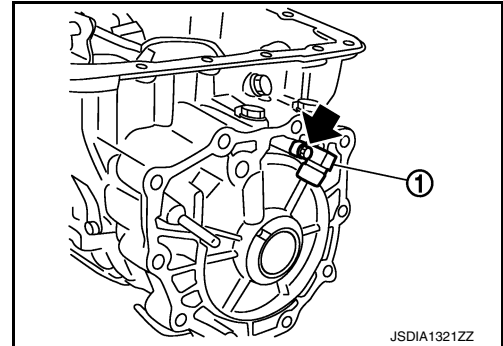

25. As shown in the figure, use the drift to drive rear oil seal into the rear extension (2WD models) (A) or adapter case (4WD models) (B) until it is flush.

**1 : Drift [ST33400001 (J-26082)]**

**2 : Drift [Commercial service tool Ø64 mm (2.52 in)]**

**CAUTION:**

- Apply ATF to rear oil seal.
- Do not reuse rear oil seal.

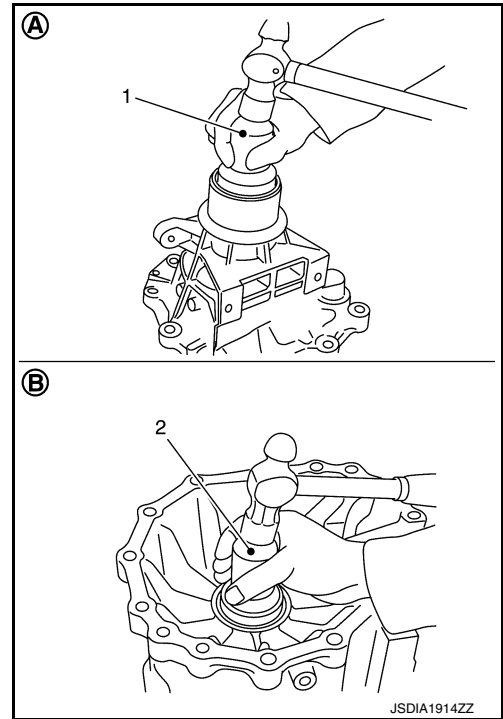

26. Install return spring (1) to parking pawl (2).

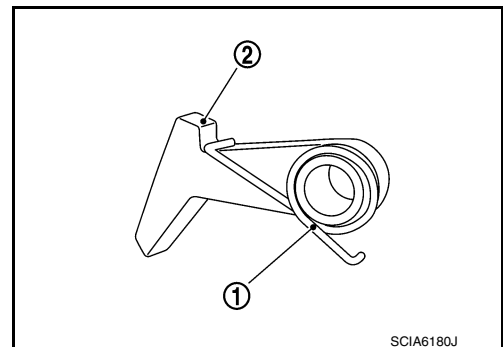

A  
B  
C  
TM  
E  
F  
G  
H  
I  
J  
K  
L  
M  
N  
O  
P

# ASSEMBLY

## < UNIT DISASSEMBLY AND ASSEMBLY >

27. Install parking pawl (with return spring) and pawl shaft to rear extension (2WD models) or adapter case (4WD models).

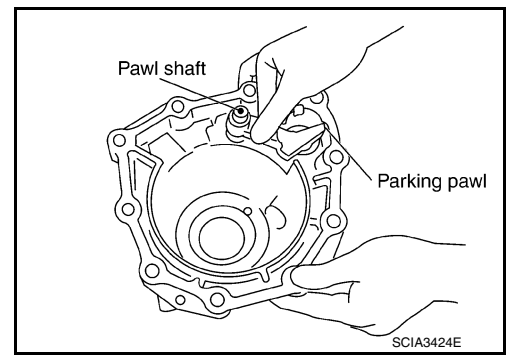

28. Install parking actuator support to rear extension (2WD models) or adapter case (4WD models).

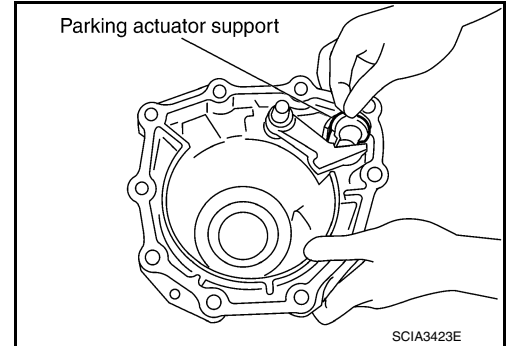

29. Install needle bearing (1) to rear extension (2WD models) or adapter case (4WD models).

**CAUTION:**

**Apply petroleum jelly to needle bearing.**

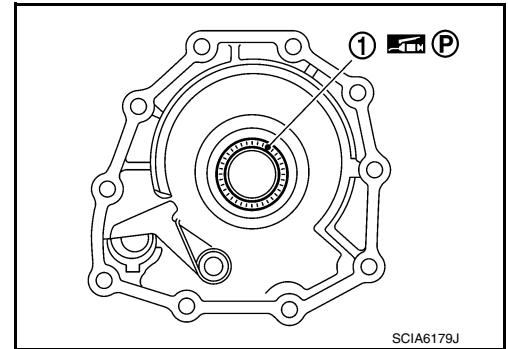

30. Install seal rings to output shaft.

**CAUTION:**

- Do not reuse seal rings.
- Apply petroleum jelly to seal rings.

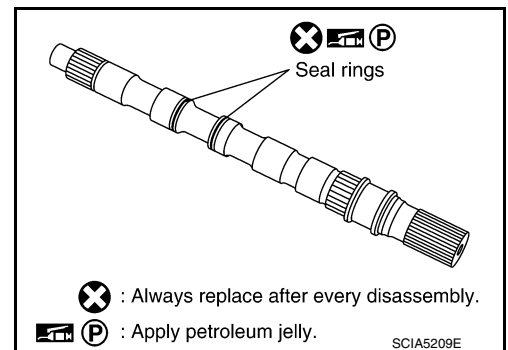

31. Install parking gear to output shaft.

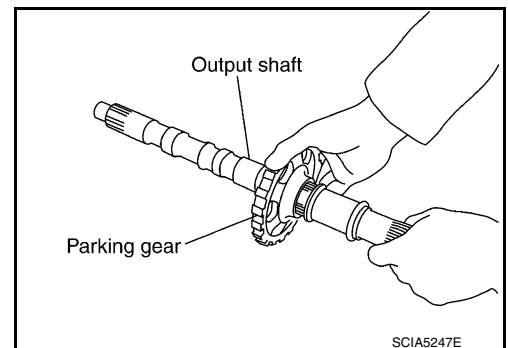



# ASSEMBLY

## < UNIT DISASSEMBLY AND ASSEMBLY >

32. Install output shaft in transmission case.

**CAUTION:**

Do not mistake front of shaft for rear because both sides look similar (thinner end is front side).

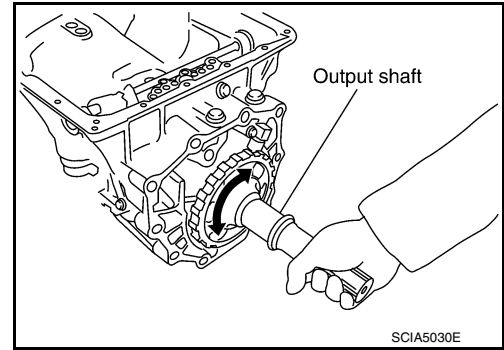

33. Install bearing race to output shaft.

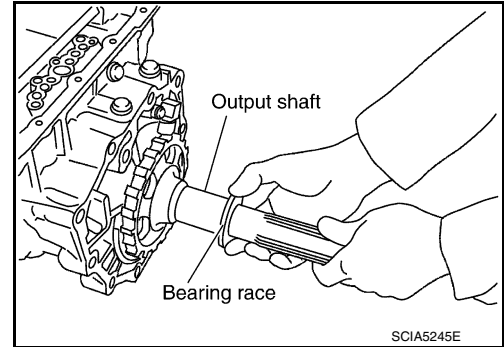

34. Install rear extension assembly (2WD models) or adapter case assembly (4WD models) according to the following procedures.

a. **2WD models**

i. Apply recommended sealant (Genuine Anaerobic Liquid Gasket or equivalent. Refer to [GI-21, "Recommended Chemical Products and Sealants"](#).) to rear extension assembly as shown.

**CAUTION:**

Completely remove all moisture, oil, old sealant and any foreign material from the transmission case and rear extension assembly mating surfaces.

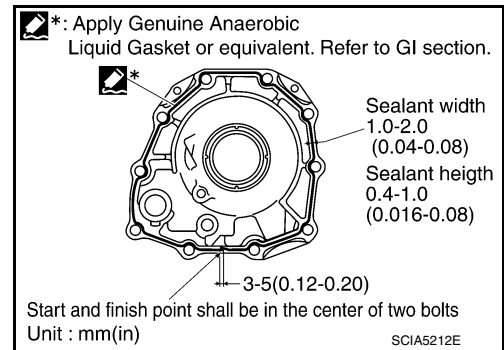

ii. Install rear extension assembly to transmission case.

**CAUTION:**

Insert the tip of parking rod between the parking pawl and the parking actuator support when assembling the rear extension assembly.

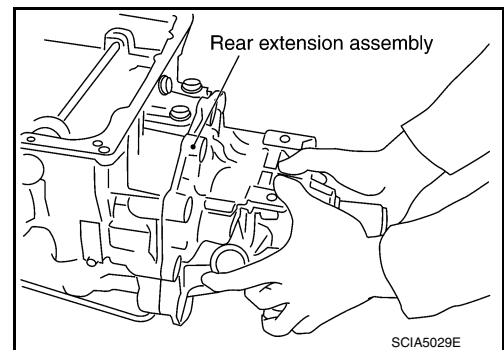

A  
B  
C  
TM  
E  
F  
G  
H  
I  
J  
K  
L  
M  
N  
O  
P

# ASSEMBLY

## < UNIT DISASSEMBLY AND ASSEMBLY >

- iii. Tighten rear extension assembly bolts (⬅) to specified torque.
- Brackets (1)
  - Self-sealing bolts (2)

**Rear extension assembly bolt : 52 N·m (5.3 kg-m, 38 ft-lb)**

**Self-sealing bolt : 61 N·m (6.2 kg-m, 45 ft-lb)**

**CAUTION:**  
Do not reuse self-sealing bolt.

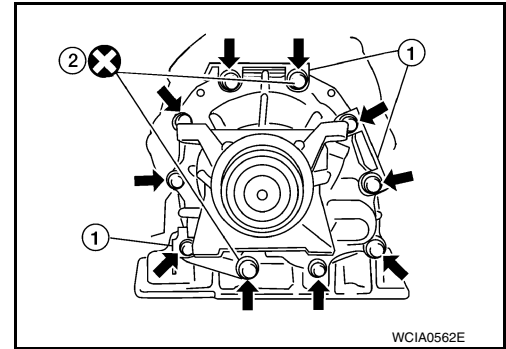

b. **4WD models**

- i. Install gasket onto transmission case.

**CAUTION:**

- Completely remove all moisture, oil, old gasket and any foreign material from the transmission case and adapter case assembly mating surfaces.
- Do not reuse gasket.

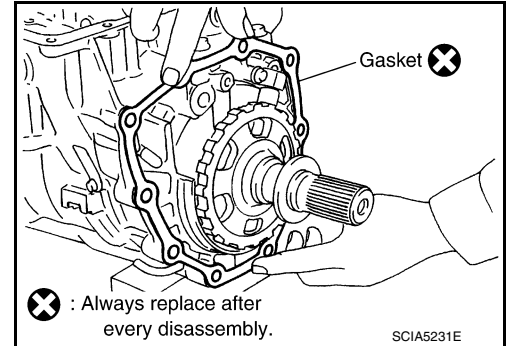

- ii. Install adapter case assembly to transmission case.

**CAUTION:**

Insert the tip of parking rod between the parking pawl and the parking actuator support when assembling the rear extension assembly.

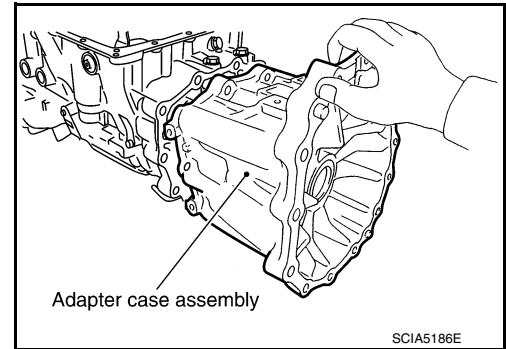

- iii. Tighten adapter case assembly bolts (⬅) to specified torque.

- Brackets (1)
- Self-sealing bolts (2)

**Adapter case assembly bolt : 52 N·m (5.3 kg-m, 38 ft-lb)**

**Self-sealing bolt : 61 N·m (6.2 kg-m, 45 ft-lb)**

**CAUTION:**  
Do not reuse self-sealing bolt.

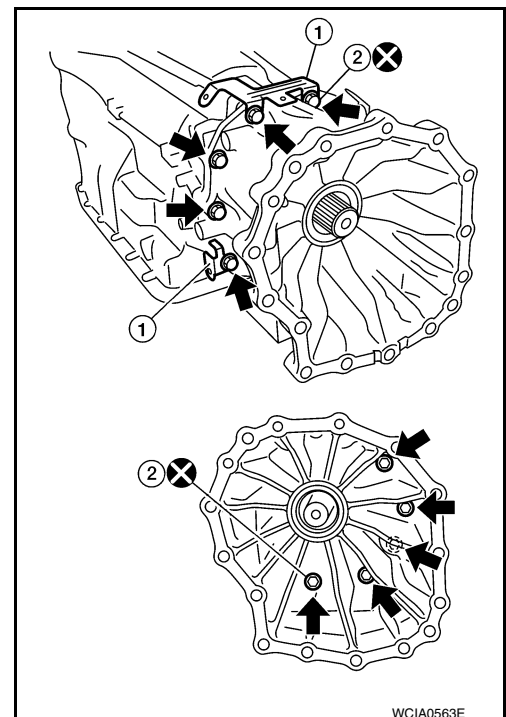

# ASSEMBLY

## < UNIT DISASSEMBLY AND ASSEMBLY >

35. Install direct clutch assembly in reverse brake.

**CAUTION:**

**Make sure that drum support edge surface and direct clutch inner boss edge surface come to almost same place.**

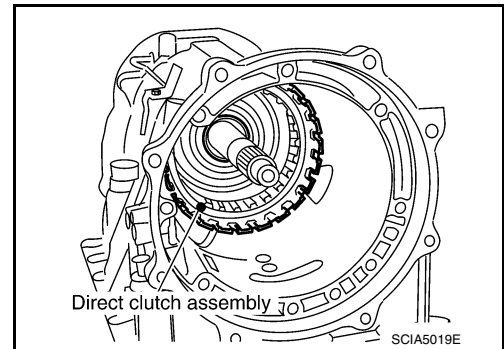

36. Install needle bearing in drum support.

**CAUTION:**

**Apply petroleum jelly to needle bearing.**

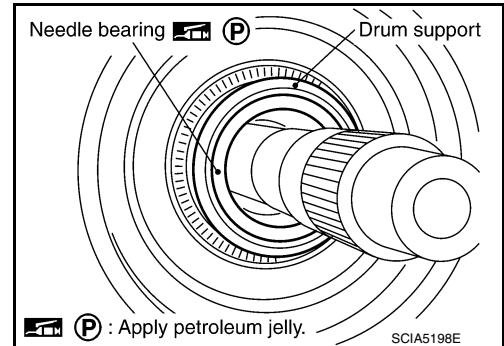

37. Install high and low reverse clutch assembly in direct clutch.

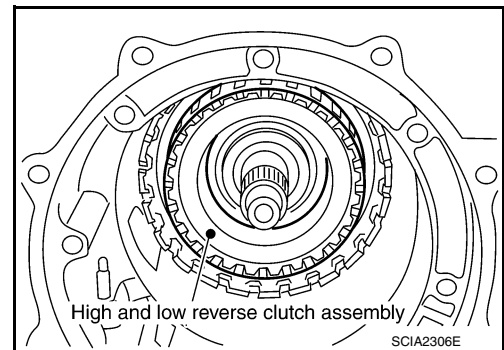

38. Align the drive plate using suitable tool.

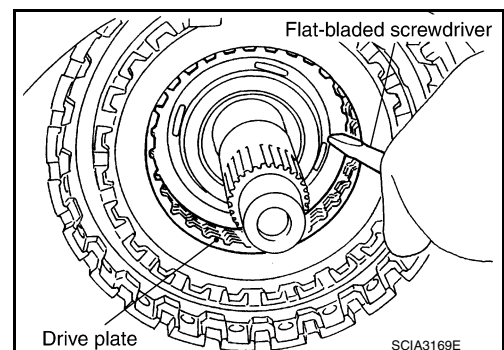

39. Install high and low reverse clutch hub, mid sun gear assembly and rear sun gear assembly as a unit.

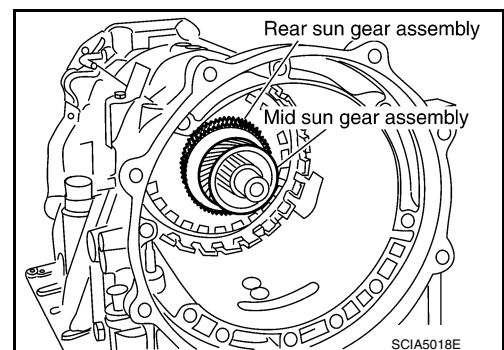

A

B

C

TM

E

F

G

H

I

J

K

L

M

N

O

P

# ASSEMBLY

## < UNIT DISASSEMBLY AND ASSEMBLY >

**CAUTION:**

Make sure that portion (A) of high and low reverse clutch drum protrudes approximately 2 mm (0.08 in) beyond portion (B) of rear sun gear.

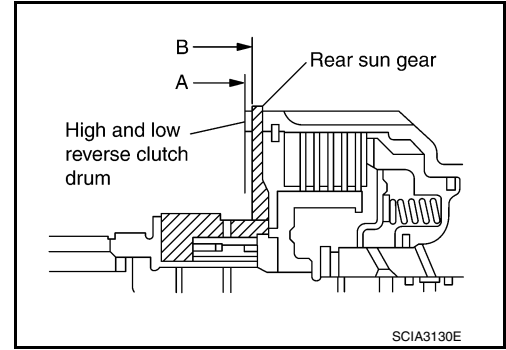

40. Install needle bearing in rear carrier assembly.

**CAUTION:**

Apply petroleum jelly to needle bearing.

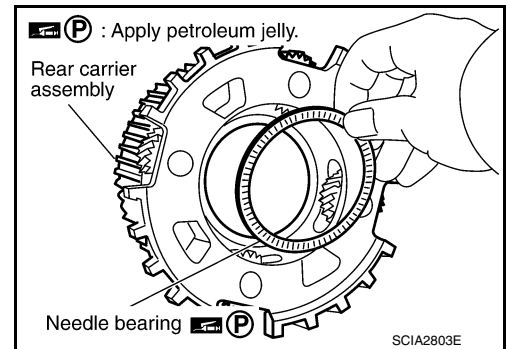

41. Install bearing race in rear carrier assembly.

**CAUTION:**

Apply petroleum jelly to bearing race.

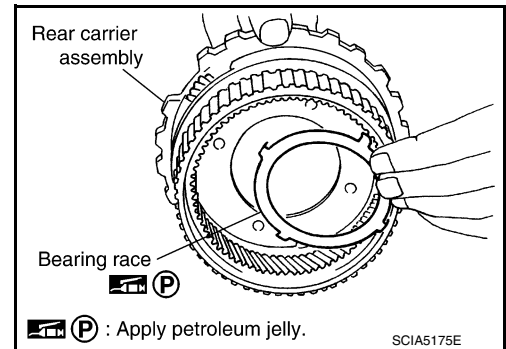

42. Install rear carrier assembly in direct clutch drum.

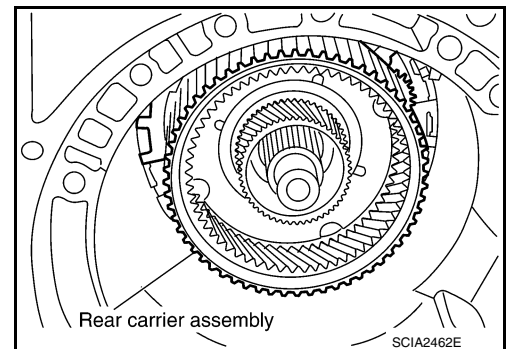

# ASSEMBLY

## < UNIT DISASSEMBLY AND ASSEMBLY >

43. Install needle bearing (rear side) to mid carrier assembly.

**CAUTION:**

**Apply petroleum jelly to needle bearing.**

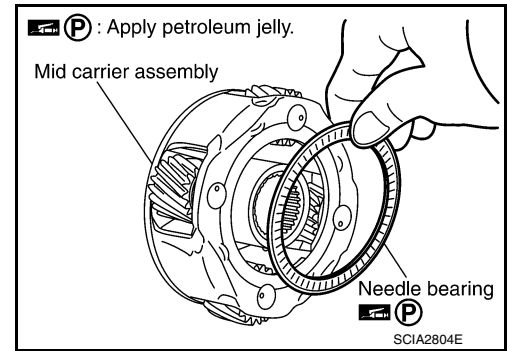

44. Install needle bearing (front side) to mid carrier assembly.

**CAUTION:**

**Apply petroleum jelly to needle bearing.**

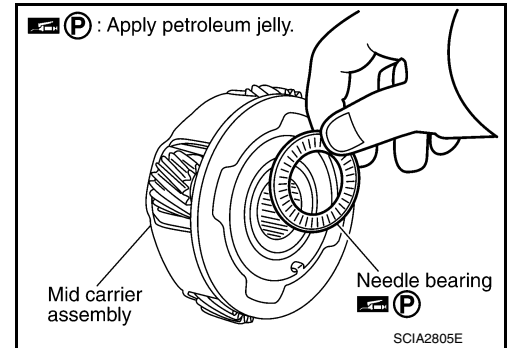

45. Install mid carrier assembly in rear carrier assembly.

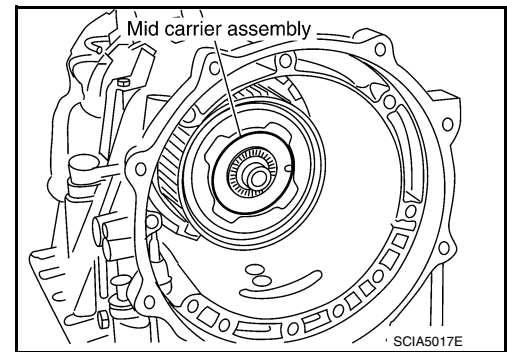

46. Install front carrier assembly, input clutch assembly and rear internal gear as a unit.

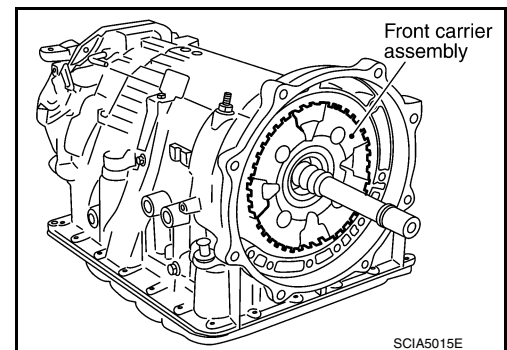

47. Install seal rings in input clutch assembly.

**CAUTION:**

- Do not reuse seal rings.
- Apply petroleum jelly to seal rings.

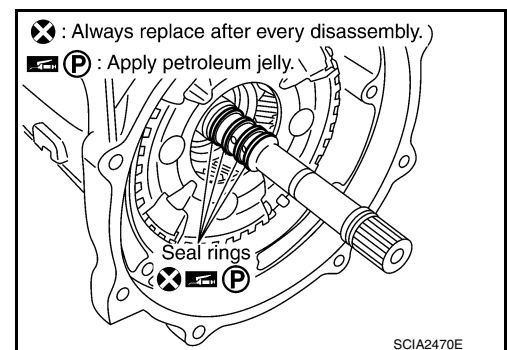

A  
B  
C  
TM  
E  
F  
G  
H  
I  
J  
K  
L  
M  
N  
O  
P

# ASSEMBLY

## < UNIT DISASSEMBLY AND ASSEMBLY >

48. Install band servo anchor end pin and lock nut in transmission case.

**CAUTION:**

Do not reuse band servo anchor end pin.

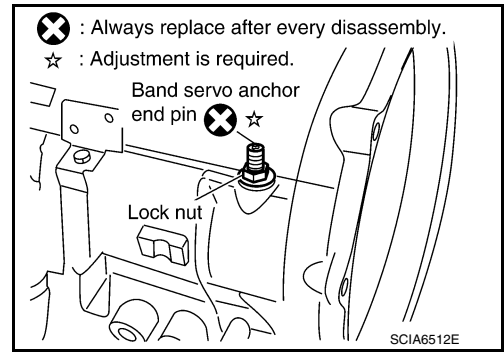

49. Install brake band in transmission case.

**CAUTION:**

Install it so that the identification to avoid incorrect installation faces the servo side.

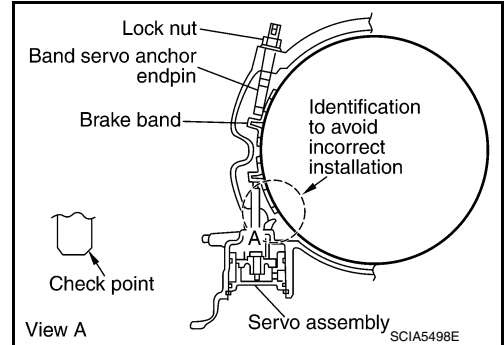

50. Install front sun gear to front carrier assembly.

**CAUTION:**

Apply ATF to front sun gear bearing and 3rd one-way clutch end bearing.

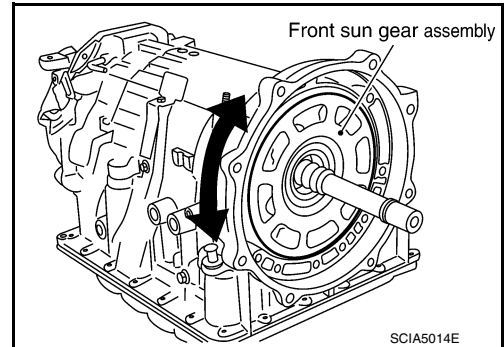

51. Install needle bearing to front sun gear.

**CAUTION:**

Apply petroleum jelly to needle bearing.

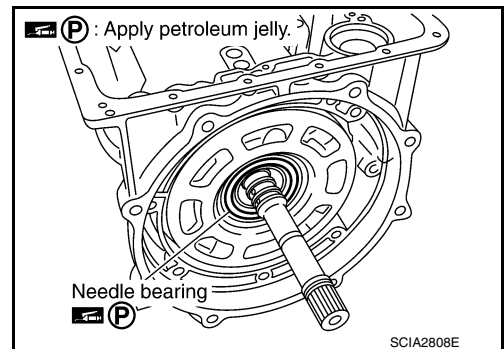

52. Adjust brake band tilting using a clip so that brake band contacts front sun gear drum evenly.

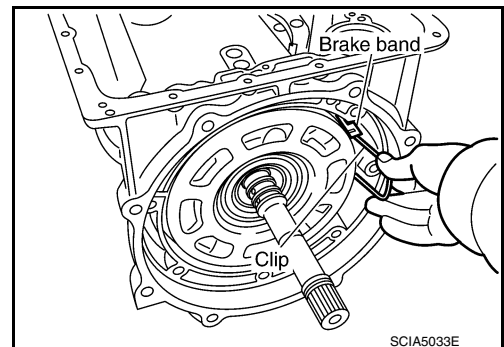

# ASSEMBLY

## < UNIT DISASSEMBLY AND ASSEMBLY >

53. Adjust brake band.

- a. Loosen lock nut.
- b. Tighten band servo anchor end pin to specified torque.

**Anchor end pin : 5.0 N·m (0.51 kg-m, 44 in-lb)**

- c. Back off band servo anchor end pin three turns.
- d. Holding band servo anchor end pin, tighten lock nut to specified torque.

**Lock nut : 46 N·m (4.7 kg-m, 34 ft-lb)**

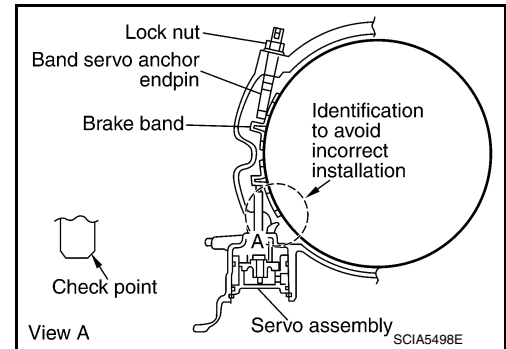

## Adjustment

INFOID:000000009885936

### TOTAL END PLAY

- Measure clearance between front sun gear and bearing race for oil pump cover.
- Select proper thickness of bearing race so that end play is within specifications.

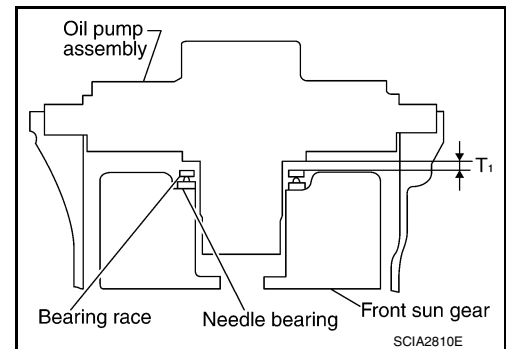

1. Measure dimensions "K" and "L" and then calculate dimension "J".

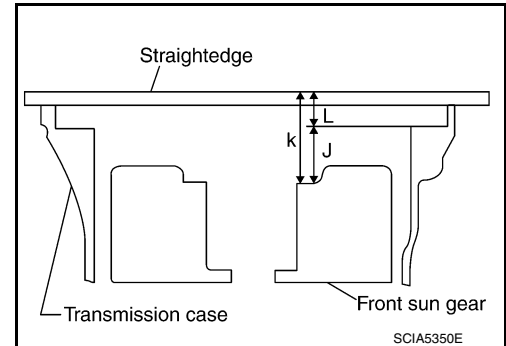

- a. Measure dimension "K".

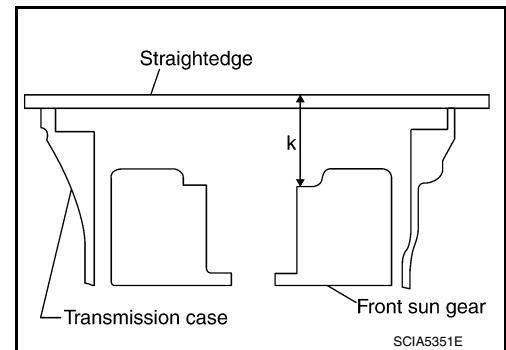

# ASSEMBLY

## < UNIT DISASSEMBLY AND ASSEMBLY >

- b. Measure dimension "L".
- c. Calculate dimension "J".

**"J": Distance between oil pump fitting surface of transmission case and needle bearing mating surface of front sun gear.**

$$J = K - L$$

- 2. Measure dimensions "M1" and "M2" and then calculate dimension "M".

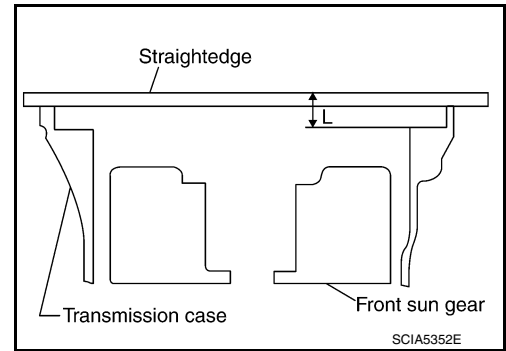

- a. Place bearing race and needle bearing on oil pump assembly.

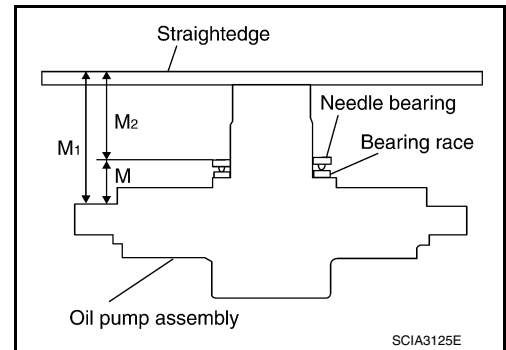

- b. Measure dimension "M1".

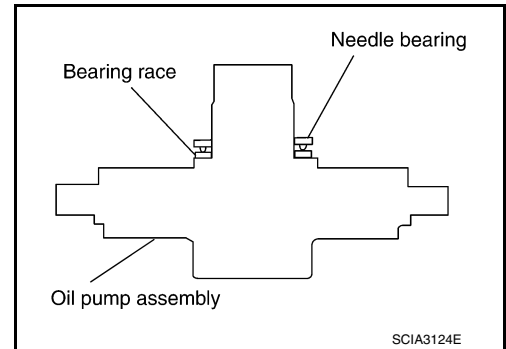

- c. Measure dimension "M2".

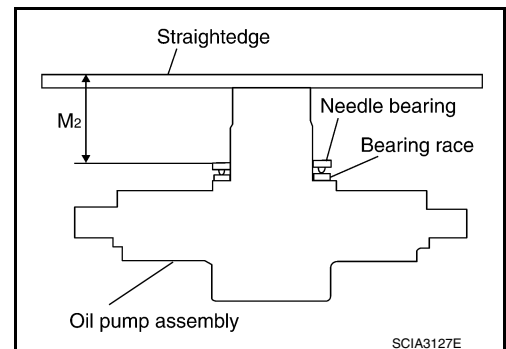
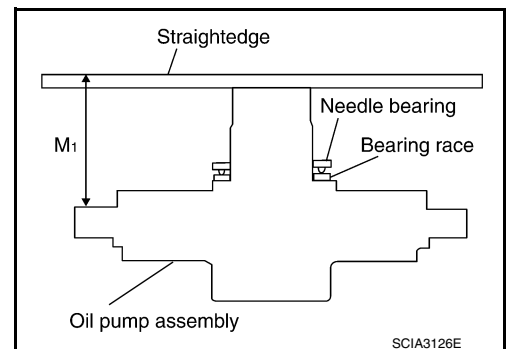



# ASSEMBLY

## < UNIT DISASSEMBLY AND ASSEMBLY >

d. Calculate dimension "M".

**"M": Distance between transmission case fitting surface of oil pump and needle bearing on oil pump.**

$$M = M_1 - M_2$$

3. Adjust total end play "T1".

$$T_1 = J - M$$

**Total end play "T1" : 0.25 - 0.55 mm (0.0098 - 0.0217 in)**

- Select proper thickness of bearing race so that total end play is within specifications.

**Bearing races** :Refer to [TM-288, "General Specification"](#).

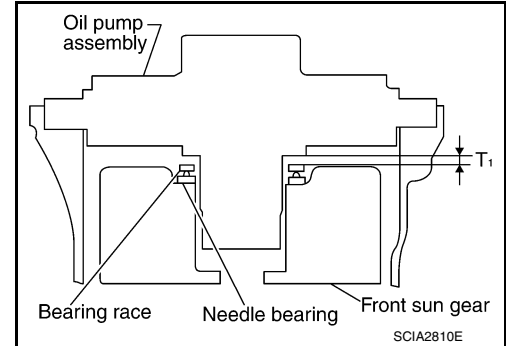
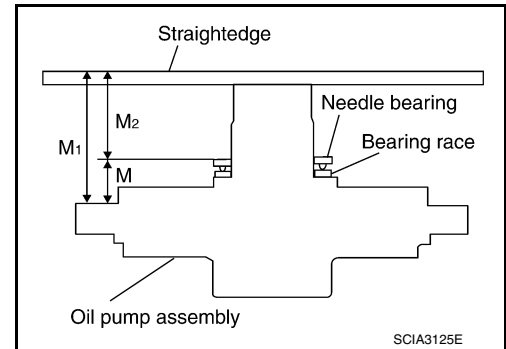

INFOID:000000009885937

## Assembly (2)

1. Install O-ring to oil pump assembly.

**CAUTION:**

- Do not reuse O-ring.
- Apply ATF to O-ring.

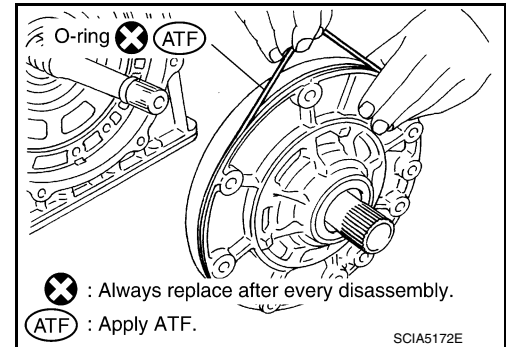

2. Install bearing race to oil pump assembly.

**CAUTION:**

**Apply petroleum jelly to bearing race.**

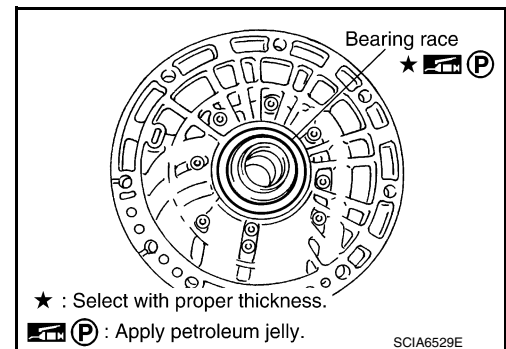

# ASSEMBLY

## < UNIT DISASSEMBLY AND ASSEMBLY >

3. Install oil pump assembly in transmission case.

**CAUTION:**

Apply ATF to oil pump bearing.

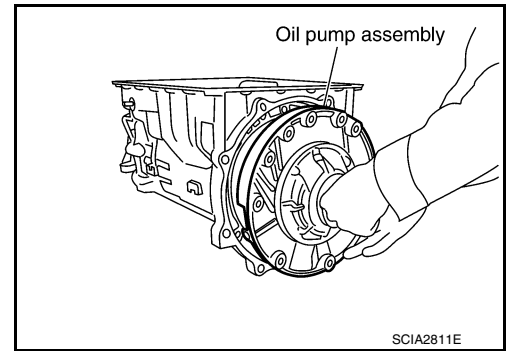

4. Apply recommended sealant (Genuine RTV Silicone Sealant or equivalent. Refer to [GI-21, "Recommended Chemical Products and Sealants"](#).) to oil pump assembly as shown.

**CAUTION:**

Completely remove all moisture, oil, old sealant and any foreign material from the oil pump bolts and oil pump bolt mating surfaces.

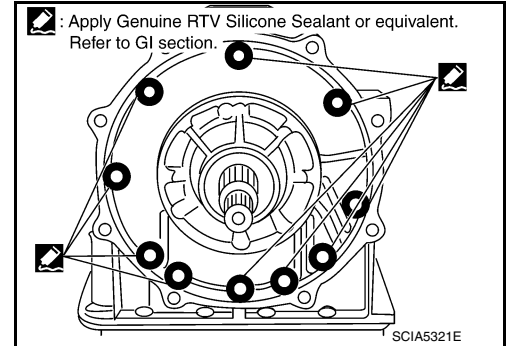

5. Tighten oil pump bolts to specified torque.

**Oil pump bolts : 48 N·m (4.9 kg-m, 35 ft-lb)**

**CAUTION:**

Apply ATF to oil pump bushing.

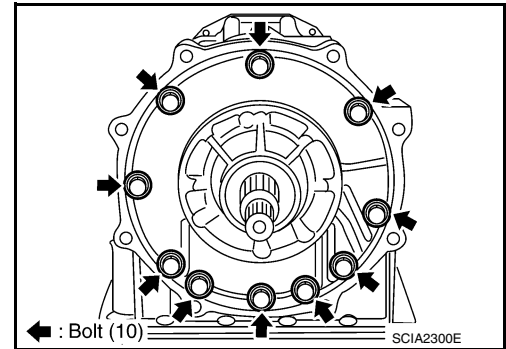

6. Install O-ring to input clutch assembly.

**CAUTION:**

- Do not reuse O-ring.
- Apply ATF to O-ring.

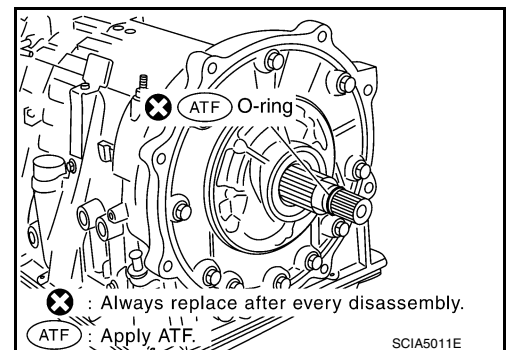

7. Install converter housing to transmission case and tighten bolts to specified torque.

**Converter housing bolt : 52 N·m (5.3 kg-m, 38 ft-lb)**

**Self-sealing bolt (A) : 61 N·m (6.2 kg-m, 45 ft-lb)**

**CAUTION:**

Do not reuse self-sealing bolt (A).

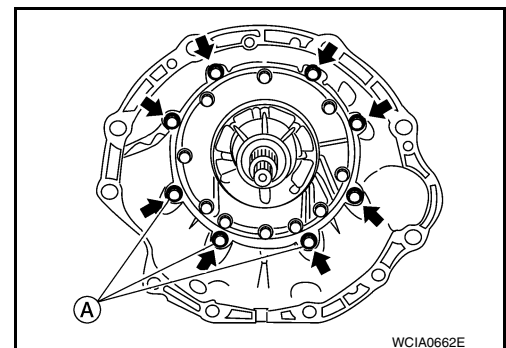

# ASSEMBLY

## < UNIT DISASSEMBLY AND ASSEMBLY >

8. Make sure that brake band (1) does not close input speed sensor hole (A).

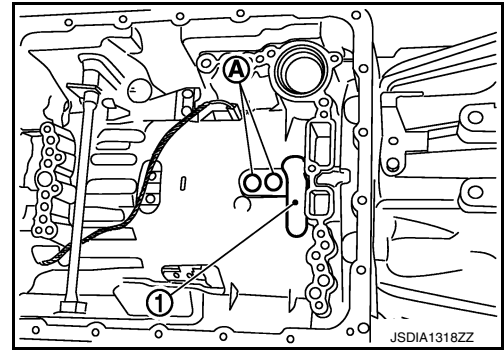

9. Connect TCM connector (1) and transmission range switch connector (2).

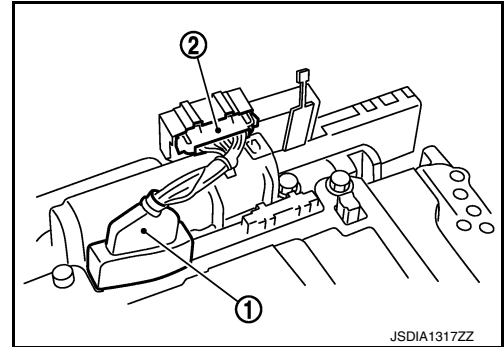

10. Install A/T assembly harness connector to control valve with TCM.

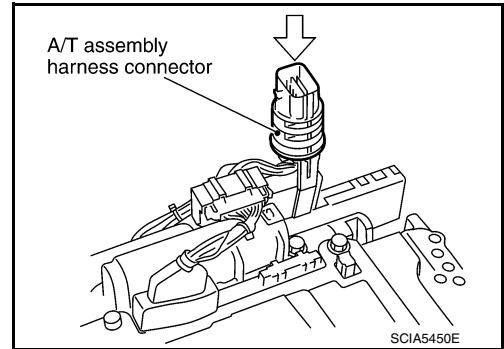

11. Connect TCM connectors.

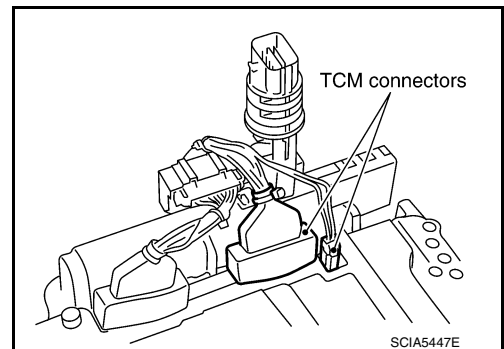

12. Install O-ring to A/T assembly harness connector.

**CAUTION:**

- Do not reuse O-ring.
- Apply ATF to O-ring.

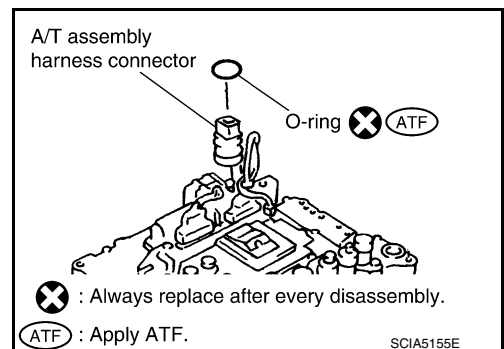

A  
B  
C  
TM  
E  
F  
G  
H  
I  
J  
K  
L  
M  
N  
O  
P

# ASSEMBLY

## < UNIT DISASSEMBLY AND ASSEMBLY >

13. Install new O-ring (1) in plug (2).

**CAUTION:**

- Do not reuse O-ring.
- Apply ATF to O-ring.
- O-ring should be free of contamination.

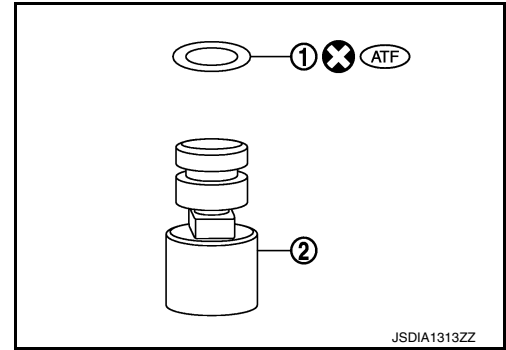

14. Install plug (2) to bracket (1).

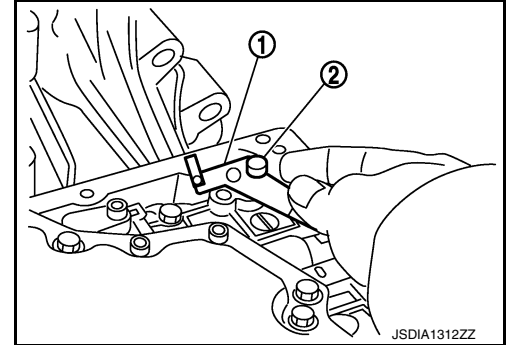

15. Install plug (1) [with bracket (2)] to control valve with TCM and tighten bolt (⬅) to specified torque.

**Bracket bolt : 7.9 N·m (0.81 kg-m, 70 in-lb)**

**CAUTION:**

**Adjust bolt hole of bracket to bolt hole of control valve.**

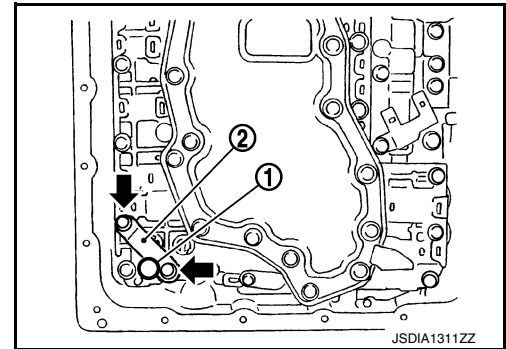

16. Install control valve with TCM in transmission case.

1 : Brake band

**CAUTION:**

- Make sure that input speed sensor is securely installed into input speed sensor hole (A).
- Hang down output speed sensor harness toward outside so as not to disturb installation of control valve with TCM.
- Adjust A/T assembly harness connector of control valve with TCM to terminal hole of transmission case.

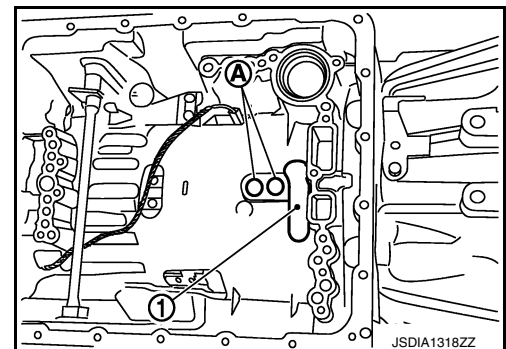

- Assemble it so that manual valve cutout is engaged with manual plate projection.

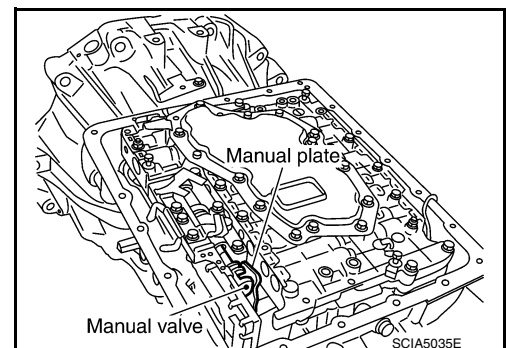

# ASSEMBLY

## < UNIT DISASSEMBLY AND ASSEMBLY >

17. Install bolts (A), (B) and (C) to control valve with TCM.

← : Front

Bolt symbol	Length mm (in)	Number of bolts
A	42 (1.65)	5
B	55 (2.17)	6
C	40 (1.57)	1

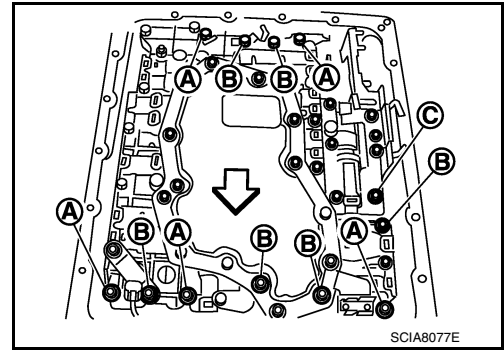

18. Tighten bolt (A), (B) and (C) temporarily to prevent dislocation. After that tighten them in order (A → B → C), and then tighten other bolts.

← : Front

Bolt symbol	A	B	C
Number of bolts	5	6	1
Length mm (in)	42 (1.65)	55 (2.17)	40 (1.57)
Tightening torque N·m (km-g, in-lb)	7.9 (0.81, 70)		With ATF applied 7.9 (0.81, 70)

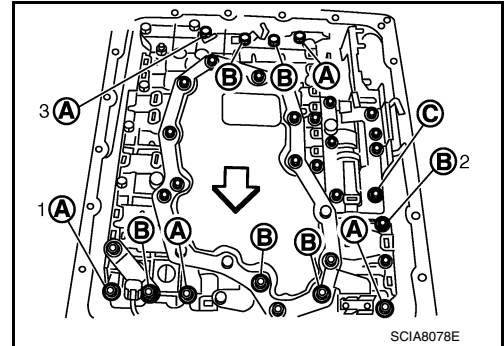

19. Connect output speed sensor connector (1).

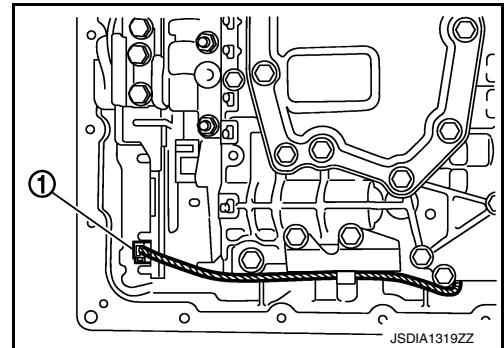

20. Securely fasten output speed sensor harness with terminal clip (←).

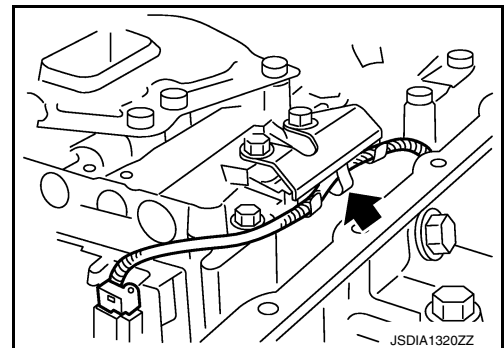

# ASSEMBLY

## < UNIT DISASSEMBLY AND ASSEMBLY >

21. Pull down A/T assembly harness connector.

**CAUTION:**

**Do not damage connector.**

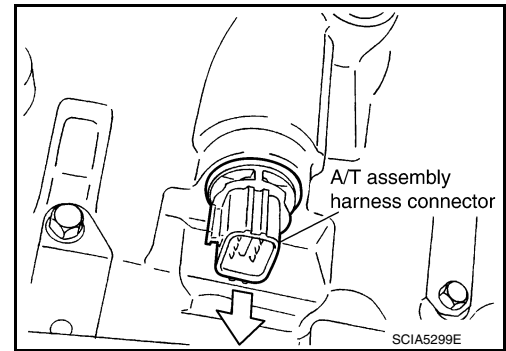

22. Install snap ring to A/T assembly harness connector.

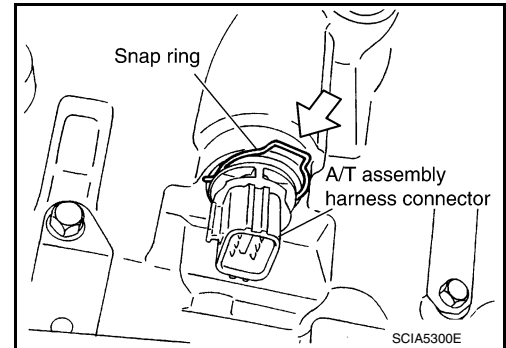

23. Install magnets in oil pan.

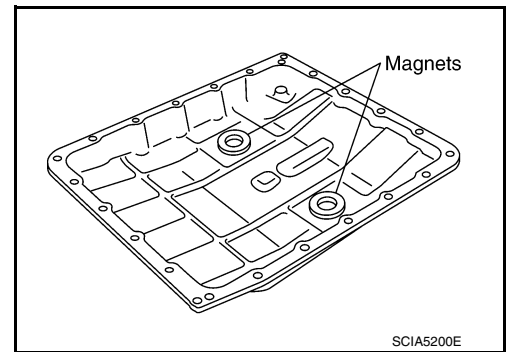

24. Install oil pan to transmission case. Refer to [TM-199, "Removal and Installation"](#).

25. Install torque converter.

a. Pour ATF into torque converter.

**NOTE:**

- Approximately 2 liters (2-1/8 US qt. 1-3/4 Imp qt) of fluid is required for a new torque converter.
- When reusing old torque converter, add the same amount of fluid as was drained.

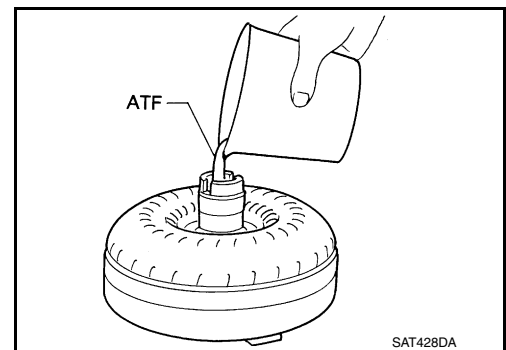

# ASSEMBLY

## < UNIT DISASSEMBLY AND ASSEMBLY >

- b. Install torque converter while aligning notches of torque converter with notches of oil pump.

**CAUTION:**

**Install torque converter while rotating it.**

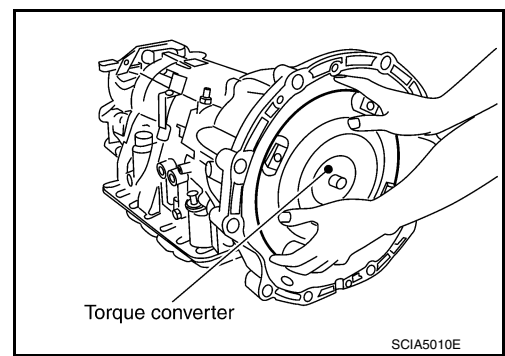

- c. Measure distance (A) to make sure that torque converter is in proper position.

**Distance (A) : 24.0 mm (0.94 in) or more**

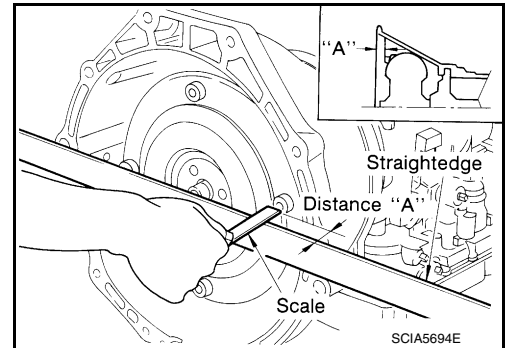

A  
B  
C  
TM  
E  
F  
G  
H  
I  
J  
K  
L  
M  
N  
O  
P

# SERVICE DATA AND SPECIFICATIONS (SDS)

< SERVICE DATA AND SPECIFICATIONS (SDS)

## SERVICE DATA AND SPECIFICATIONS (SDS)

### SERVICE DATA AND SPECIFICATIONS (SDS)

#### General Specification

INFOID:000000009885938

Applied model		2WD		4WD	
Automatic transmission model		RE5R05A			
Transmission model code number		63X2B	63X3A	63X2C	63X2E
Stall torque ratio		2.0 : 1			
Transmission gear ratio	1st	3.827			
	2nd	2.368			
	3rd	1.520			
	4th	1.000			
	5th	0.834			
	Reverse	2.613			
Remarks	Final gear ratio	2.937	3.357	2.937	3.357
Recommended fluid		Genuine NISSAN Matic S ATF*1			
Fluid capacity		10.6 liter (11-1/4 US qt, 9-3/8 Imp qt)*2			

#### CAUTION:

- If Genuine NISSAN Matic S ATF is not available, Genuine NISSAN Matic J ATF may also be used. Using ATF other than Genuine NISSAN Matic S ATF or Matic J ATF will cause deterioration driveability and A/T durability, and may damage the A/T, which is not covered by the NISSAN new vehicle limited warranty.

\*1: Refer to [MA-15. "FOR NORTH AMERICA : Fluids and Lubricants"](#) (For USA and Canada) [MA-16. "FOR MEXICO : Fluids and Lubricants"](#) (Mexico).

\*2: The fluid capacity is the reference value. Check the fluid level with A/T fluid level gauge.

#### Vehicle Speed at Which Gear Shifting Occurs

INFOID:000000009885939

#### NORMAL MODE

Final gear ratio	Throttle position	Vehicle speed km/h (MPH)							
		D1 →D2	D2 →D3	D3 →D4	D4 →D5	D5 →D4	D4 →D3	D3 →D2	D2 →D1
2.937	Full throttle	70 - 74 (44 - 46)	112 - 120 (70 - 75)	176 - 186 (110 - 116)	249 - 259 (155 - 161)	245 - 255 (152 - 159)	166 - 176 (103 - 110)	100 - 108 (62 - 67)	43 - 47 (27 - 30)
	Half throttle	46 - 50 (28 - 31)	75 - 81 (47 - 50)	104 - 112 (65 - 70)	136 - 144 (85 - 89)	111 - 119 (69 - 74)	75 - 83 (47 - 51)	44 - 50 (27 - 31)	11 - 15 (7 - 10)
3.357	Full throttle	61 - 65 (38 - 41)	97 - 105 (61 - 66)	153 - 163 (95 - 102)	236 - 246 (147 - 153)	232 - 242 (144 - 151)	143 - 153 (89 - 95)	87 - 95 (54 - 59)	43 - 47 (27 - 29)
	Half throttle	41 - 45 (26 - 28)	67 - 73 (42 - 45)	90 - 98 (56 - 61)	119 - 127 (74 - 79)	97 - 105 (60 - 65)	65 - 73 (40 - 45)	39 - 45 (24 - 28)	11 - 15 (7 - 10)

- At half throttle, the accelerator opening is 1/2 of the full opening.

#### TOW MODE

Final gear ratio	Throttle position	Vehicle speed km/h (MPH)							
		D1 →D2	D2 →D3	D3 →D4	D4 →D5	D5 →D4	D4 →D3	D3 →D2	D2 →D1
2.937	Full throttle	70 - 74 (44 - 46)	112 - 120 (70 - 75)	176 - 186 (110 - 116)	249 - 259 (155 - 161)	245 - 255 (152 - 159)	166 - 176 (103 - 110)	100 - 108 (62 - 67)	43 - 47 (27 - 30)
	Half throttle	50 - 54 (31 - 34)	82 - 88 (51 - 55)	114 - 122 (71 - 76)	136 - 144 (85 - 89)	111 - 119 (69 - 74)	76 - 84 (47 - 52)	44 - 50 (27 - 31)	11 - 15 (7 - 10)



# SERVICE DATA AND SPECIFICATIONS (SDS)

## < SERVICE DATA AND SPECIFICATIONS (SDS)

3.357	Full throttle	61 - 65 (38 - 41)	97 - 105 (61 - 66)	153 - 163 (95 - 102)	236 - 246 (147 - 153)	232 - 242 (144 - 151)	143 - 153 (89 - 95)	87 - 95 (54 - 59)	43 - 47 (27 - 29)
	Half throttle	46 - 50 (29 - 31)	73 - 79 (45 - 59)	99 - 107 (62 - 66)	119 - 127 (74 - 79)	97 - 105 (60 - 65)	65 - 73 (40 - 45)	39 - 45 (24 - 28)	11 - 15 (7 - 10)

- At half throttle, the accelerator opening is 1/2 of the full opening.

## Vehicle Speed at Which Lock-up Occurs/Releases

INFOID:000000009885940

Final gear ratio	Throttle position	Vehicle speed km/h (MPH)	
		Lock-up ON	Lock-up OFF
2.937	Closed throttle	51 - 59 (32 - 36)	48 - 56 (30 - 34)
	Half throttle	177 - 185 (110 - 115)	111 - 119 (69 - 73)
3.357	Closed throttle	44 - 52 (28 - 32)	41 - 49 (26 - 30)
	Half throttle	161 - 169 (100 - 105)	97 - 105 (61 - 65)

- At closed throttle, the accelerator opening is less than 1/8 condition. (Closed throttle position signal OFF)
- At half throttle, the accelerator opening is 1/2 of the full opening.

## Stall Speed

INFOID:000000009885941

Stall speed	2,550 - 2,850 rpm
-------------	-------------------

## Line Pressure

INFOID:000000009885942

Engine speed	Line pressure kPa (kg/cm <sup>2</sup> , psi)	
	"R" position	"D" position
At idle speed	425 - 465 (4.3 - 4.7, 62 - 67)	379 - 428 (3.9 - 4.4, 55 - 62)
At stall speed	1,605 - 1,950 (16.4 - 19.9, 233 - 283)	1,310 - 1,500 (13.4 - 15.3, 190 - 218)

## Input Speed Sensor

INFOID:000000009885943

Name	Condition	Data (Approx.)
Input speed sensor 1	When running at 50 km/h (31 MPH) in 4th speed with the closed throttle position signal OFF.	1.3 kHz
Input speed sensor 2	When running at 20 km/h (12 MPH) in 1st speed with the closed throttle position signal OFF.	

## Output Speed Sensor

INFOID:000000009885944

Name	Condition	Data (Approx.)
Output speed sensor	When running at 20 km/h (12 MPH).	185 Hz

## Reverse Brake

INFOID:000000009885945

Number of drive plates	7
Number of driven plates	7
Clearance mm (in)	Standard 0.7 - 1.1 (0.028 - 0.043)

# SERVICE DATA AND SPECIFICATIONS (SDS)

## < SERVICE DATA AND SPECIFICATIONS (SDS)

	Thickness mm (in)
Thickness of retaining plates	4.2 (0.165)
	4.4 (0.173)
	4.6 (0.181)
	4.8 (0.189)
	5.0 (0.197)
	5.2 (0.205)
	5.4 (0.213)

## Total End Play

INFOID:000000009885946

Total end play mm (in)	0.25 – 0.55 (0.0098 – 0.0217)
------------------------	-------------------------------

## BEARING RACE FOR ADJUSTING TOTAL END PLAY

Thickness mm (in)
0.8 (0.031)
1.0 (0.039)
1.2 (0.047)
1.4 (0.055)
1.6 (0.063)
1.8 (0.071)

## Torque Converter

INFOID:000000009885947

Distance between end of converter housing and torque converter mm (in)	24.0 (0.94) or more
--	---------------------