

SECTION **DEF**
DEFOGGER

A
B
C

CONTENTS

BASIC INSPECTION	3	Component Function Check	12	F
DIAGNOSIS AND REPAIR WORKFLOW	3	Diagnosis Procedure	12	
Repair Work Flow	3	Component Inspection	14	
SYSTEM DESCRIPTION	5	DOOR MIRROR DEFOGGER LH	15	G
REAR WINDOW DEFOGGER SYSTEM	5	Description	15	
System Diagram	5	Component Function Check	15	H
System Description	5	Diagnosis Procedure	15	
Component Parts Location	6	Component Inspection (With Automatic Drive Po- sitioner)	17	I
Component Description	6	Component Inspection (Without Automatic Drive Positioner)	17	
DIAGNOSIS SYSTEM (BCM)	7	DOOR MIRROR DEFOGGER RH	18	J
COMMON ITEM	7	Description	18	
COMMON ITEM : CONSULT Function (BCM - COMMON ITEM)	7	Component Function Check	18	K
REAR DEFOGGER	7	Diagnosis Procedure	18	
REAR DEFOGGER : CONSULT Function (BCM - REAR DEFOGGER)	8	Component Inspection (With Automatic Drive Po- sitioner)	20	
DTC/CIRCUIT DIAGNOSIS	9	Component Inspection (Without Automatic Drive Positioner)	20	DEF
REAR WINDOW DEFOGGER SWITCH	9	ECU DIAGNOSIS INFORMATION	21	
Description	9	BCM (BODY CONTROL MODULE)	21	M
Component Function Check (2 Control Dial Sys- tem or Auto A/C)	9	Reference Value	21	
Component Function Check (3 Control Dial Sys- tem Without Auto A/C)	9	Terminal Layout	24	N
Diagnosis Procedure (2 Control Dial System or Auto A/C)	9	Physical Values	24	
Diagnosis Procedure (3 Control Dial System With- out Auto A/C)	10	Fail Safe	29	O
REAR WINDOW DEFOGGER RELAY	11	DTC Inspection Priority Chart	29	
Description	11	DTC Index	30	
Component Function Check	11	WIRING DIAGRAM	32	P
Diagnosis Procedure	11	REAR WINDOW DEFOGGER	32	
REAR WINDOW DEFOGGER SYSTEM	12	Wiring Diagram	32	
Description	12	SYMPTOM DIAGNOSIS	40	
		REAR WINDOW DEFOGGER SYSTEM SYMPTOMS	40	
		Symptom Table	40	

REAR WINDOW DEFOGGER AND DOOR MIRROR DEFOGGER DO NOT OPERATE.	41	Diagnosis Procedure	45
Diagnosis Procedure	41	REAR WINDOW DEFOGGER SWITCH DOES NOT LIGHT, BUT REAR WINDOW DEFOGGER OPERATES	46
REAR WINDOW DEFOGGER DOES NOT OPERATE BUT BOTH OF DOOR MIRROR DEFOGGER OPERATE.	42	Diagnosis Procedure	46
Diagnosis Procedure	42	PRECAUTION	47
BOTH DOORS MIRROR DEFOGGER DON'T OPERATE BUT REAR WINDOW DEFOGGER OPERATES	43	PRECAUTIONS	47
Diagnosis Procedure	43	Precaution for Supplemental Restraint System (SRS) "AIR BAG" and "SEAT BELT PRE-TENSIONER"	47
DRIVER SIDE DOOR MIRROR DEFOGGER DOES NOT OPERATE.	44	Handling for Adhesive and Primer	47
Diagnosis Procedure	44	REMOVAL AND INSTALLATION	48
PASSENGER SIDE DOOR MIRROR DEFOGGER DOES NOT OPERATE.	45	REAR WINDOW DEFOGGER	48
		Filament Check	48
		Filament Repair	48

DIAGNOSIS AND REPAIR WORKFLOW

< BASIC INSPECTION >

BASIC INSPECTION

DIAGNOSIS AND REPAIR WORKFLOW

Repair Work Flow

INFOID:000000011560002

WORK FLOW

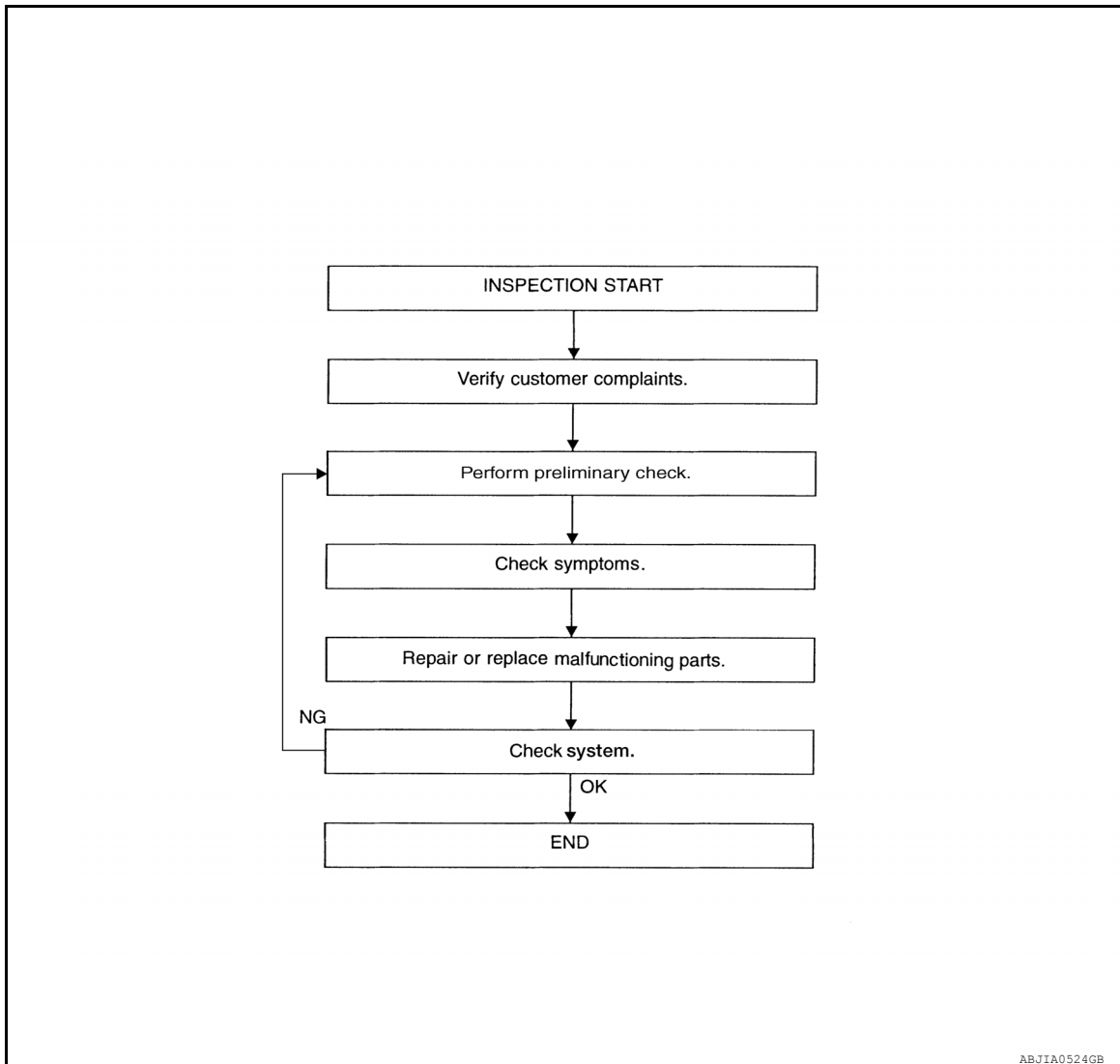

DETAILED FLOW

1. CUSTOMER INFORMATION

Talk to the customer to obtain detailed information about the symptom.

>> GO TO 2

2. SYSTEM DESCRIPTION

Perform preliminary check. Refer to [DEF-5. "System Description"](#).

>> GO TO 3

3. SYMPTOM

Check for symptoms. Refer to [DEF-40. "Symptom Table"](#).

DIAGNOSIS AND REPAIR WORKFLOW

< BASIC INSPECTION >

>> GO TO 4

4. MALFUNCTIONING PARTS

Repair or replace the applicable parts.

>> GO TO 5

5. SYSTEM CHECK

Operate rear window defogger switch to ensure that rear window defogger and heated mirrors operate.

Does the system operate normally?

YES >> Inspection End

NO >> Refer to [GI-44, "Intermittent Incident"](#).

REAR WINDOW DEFOGGER SYSTEM

< SYSTEM DESCRIPTION >

SYSTEM DESCRIPTION

REAR WINDOW DEFOGGER SYSTEM

System Diagram

INFOID:000000011560003

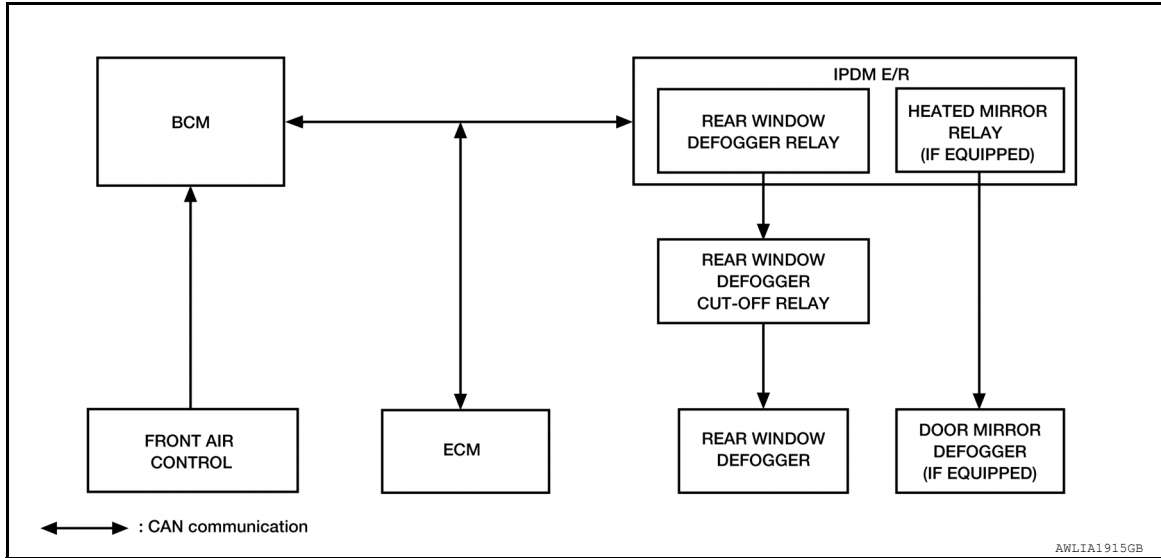

System Description

INFOID:000000011560004

Operation Description

- When rear window defogger switch is turned ON while ignition switch is ON, the front air control (rear window defogger switch) transmits rear window defogger switch signal to BCM.
- BCM transmits rear window defogger control signal to IPDM E/R and display unit via CAN communication when rear window defogger operates.
- IPDM E/R turns rear window defogger relay and heated mirror relay ON when rear window defogger switch signal is received.
- Rear window defogger and door mirror defogger are supplied with power and operate when rear window defogger relay and heated mirror relay turn ON.
- Rear window defogger ON is displayed when signal is received.

Timer function

- BCM turns rear window defogger relay and heated mirror relay ON for approximately 15 minutes when rear window defogger switch is turned ON while ignition switch is ON. It makes rear window defogger and door mirror defogger operate.
- Timer is canceled after pressing rear window defogger switch again during timer operation. Then BCM turns rear window defogger relay and heated mirror relay OFF. The same reaction also occurs during timer operation, if the ignition switch is turned OFF.

INPUT/OUTPUT SIGNAL CHART

Switch	Input signal to BCM	BCM function	Actuator
Rear window defogger switch	Defogger switch signal	Rear window defogger and door mirror defogger control (if equipped)	Rear window defogger Door mirror defogger (if equipped)
Ignition switch	Ignition signal		

REAR WINDOW DEFOGGER SYSTEM

< SYSTEM DESCRIPTION >

Component Parts Location

INFOID:000000011560005

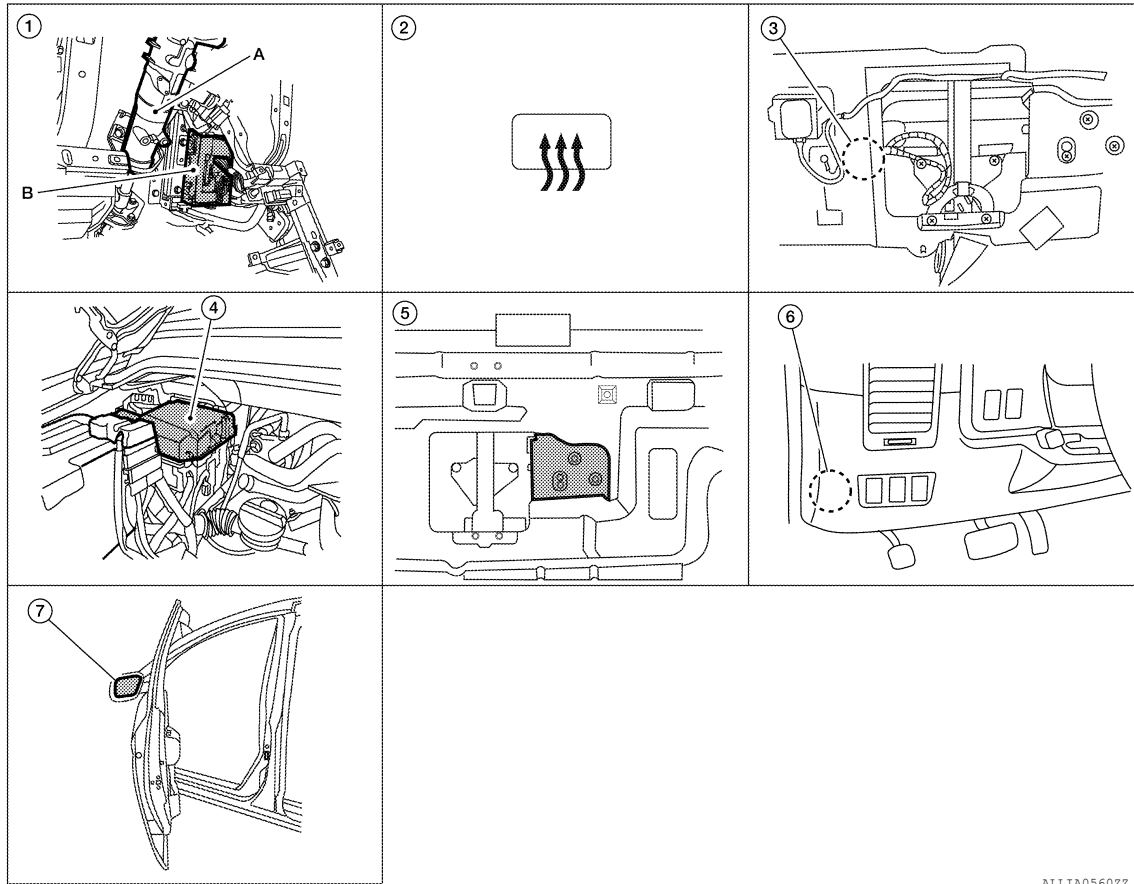

ALLIA05602Z

- | | | |
|--|--|--|
| <p>1. A. Steering column
B. BCM M18, M19, M20 (view with instrument panel removed)</p> | <p>2. Front air control
M49, M50 (with auto A/C)
M176, M177 (with manual 3 control dial system)
M180, M181 (with manual 2 control dial system)</p> | <p>3. Rear window defogger connectors
B78, B81</p> |
| <p>4. IPDM E/R (rear window defogger relay and heated mirror relay) E120, E122, E124</p> | <p>5. Rear power drop glass motor (def cut-off switch) B80</p> | <p>6. Rear window defogger cut-off relay
M187</p> |
| <p>7. Door mirror (door mirror defogger) (if equipped)
LH D4 (with automatic drive positioner)
LH D6 (without automatic drive positioner)
RH D107 (with automatic drive positioner)
RH D106 (without automatic drive positioner)</p> | | |

Component Description

INFOID:000000011560006

BCM	<ul style="list-style-type: none"> Operates the rear window defogger with the operation of rear window defogger switch. Performs the timer control of rear window defogger.
Rear window defogger relay	<ul style="list-style-type: none"> Operates the rear window defogger with the control signal from BCM.
Front air control (rear window defogger switch)	<ul style="list-style-type: none"> The rear window defogger switch is turned ON. Turns the indicator lamp ON when detecting the operation of rear window defogger.
Rear window defogger	<ul style="list-style-type: none"> Heats the heating wire with the power supply from the rear window defogger relay to prevent the rear window from fogging up.
Heated mirror relay (if equipped)	<ul style="list-style-type: none"> Operates the door mirror defogger with the control signal from BCM.
Door mirror defogger (if equipped)	<ul style="list-style-type: none"> Heats the heating wire with the power supply from the heated mirror relay to prevent the door mirror from fogging up.

DIAGNOSIS SYSTEM (BCM)

< SYSTEM DESCRIPTION >

DIAGNOSIS SYSTEM (BCM)

COMMON ITEM

COMMON ITEM : CONSULT Function (BCM - COMMON ITEM)

INFOID:0000000011875466

APPLICATION ITEM

CONSULT performs the following functions via CAN communication with BCM:

Direct Diagnostic Mode	Description
Ecu Identification	The BCM part number is displayed.
Self Diagnostic Result	The BCM self diagnostic results are displayed.
Data Monitor	The BCM input/output data is displayed in real time.
Active Test	The BCM activates outputs to test components.
Work support	The settings for BCM functions can be changed.
Configuration	<ul style="list-style-type: none"> • The vehicle specification can be read and saved. • The vehicle specification can be written when replacing BCM.
CAN Diag Support Mntr	The result of transmit/receive diagnosis of CAN communication is displayed.

SYSTEM APPLICATION

BCM can perform the following functions:

System	Sub System	Direct Diagnostic Mode						
		Ecu Identification	Self Diagnostic Result	Data Monitor	Active Test	Work support	Configuration	CAN Diag Support Mntr
Door lock	DOOR LOCK			x	x	x		
Rear window defogger	REAR DEFOGGER			x	x			
Warning chime	BUZZER			x	x			
Interior room lamp timer	INT LAMP			x	x	x		
Remote keyless entry system	MULTI REMOTE ENT			x	x	x		
Exterior lamp	HEADLAMP			x	x	x		
Wiper and washer	WIPER			x	x	x		
Turn signal and hazard warning lamps	FLASHER			x	x			
Air conditioner	AIR CONDITIONER			x				
Combination switch	COMB SW			x				
BCM	BCM	x	x			x	x	x
Immobilizer	IMMU		x	x	x			
Interior room lamp battery saver	BATTERY SAVER			x	x	x		
Vehicle security system	THEFT ALM			x	x	x		
RAP system	RETAINED PWR			x	x	x		
Signal buffer system	SIGNAL BUFFER			x	x			
TPMS	AIR PRESSURE MONITOR		x	x	x	x		
Panic alarm system	PANIC ALARM				x			

REAR DEFOGGER

DIAGNOSIS SYSTEM (BCM)

< SYSTEM DESCRIPTION >

REAR DEFOGGER : CONSULT Function (BCM - REAR DEFOGGER)

INFOID:000000011875467

DATA MONITOR

Monitor Item [Unit]	Description
IGN ON SW [On/Off]	Indicates condition of ignition switch ON position.
ACC ON SW [On/Off]	Indicates condition of ignition switch ACC position.
REAR DEF SW [On/Off]	Indicates condition of rear window defogger switch.

ACTIVE TEST

Test Item	Description
REAR DEFOGGER	This test is able to check rear window defogger operation [Off/On].

REAR WINDOW DEFOGGER SWITCH

< DTC/CIRCUIT DIAGNOSIS >

DTC/CIRCUIT DIAGNOSIS

REAR WINDOW DEFOGGER SWITCH

Description

INFOID:0000000011560009

- The rear window defogger is operated by turning the rear window defogger switch ON.
- Turns the indicator lamp in the rear window defogger switch ON when operating the rear window defogger.

Component Function Check (2 Control Dial System or Auto A/C)

INFOID:0000000011560010

1. CHECK REAR WINDOW DEFOGGER SWITCH FUNCTION

Check that the indicator lamp of rear window defogger illuminates with rear window defogger switch ON.

Is the inspection result normal?

YES >> Rear window defogger switch function is OK.

NO >> Refer to [DEF-9. "Diagnosis Procedure \(2 Control Dial System or Auto A/C\)".](#)

Component Function Check (3 Control Dial System Without Auto A/C)

INFOID:0000000011560011

1. CHECK REAR WINDOW DEFOGGER SWITCH FUNCTION

Check that the indicator lamp of rear window defogger illuminates with rear window defogger switch ON.

Is the inspection result normal?

YES >> Rear window defogger switch function is OK.

NO >> Refer to [DEF-10. "Diagnosis Procedure \(3 Control Dial System Without Auto A/C\)".](#)

Diagnosis Procedure (2 Control Dial System or Auto A/C)

INFOID:0000000011560012

Regarding Wiring Diagram information, refer to [DEF-32. "Wiring Diagram".](#)

1. CHECK FRONT AIR CONTROL (REAR WINDOW DEFOGGER SWITCH) CIRCUIT

Operate the rear window defogger switch.

Is the inspection result normal?

YES >> Inspection End.

NO >> GO TO 2

2. CHECK HARNESS CONTINUITY

1. Turn ignition switch OFF.
2. Disconnect BCM and front air control.
3. Check continuity between BCM connector and front air control connector.

BCM connector	Terminal	Front air control connector	Terminal	Continuity
M19	41	M49 (with auto A/C)	16	Yes
		M180 (with manual A/C)		

4. Check continuity between BCM connector and ground.

BCM connector	Terminal	Ground	Continuity
M19	41		No

Is the inspection result normal?

YES >> Replace front air control. Refer to [VTL-8. "Removal and Installation".](#)

NO >> Repair or replace harness.

REAR WINDOW DEFOGGER SWITCH

< DTC/CIRCUIT DIAGNOSIS >

Diagnosis Procedure (3 Control Dial System Without Auto A/C)

INFOID:000000011560013

Regarding Wiring Diagram information, refer to [DEF-32. "Wiring Diagram"](#).

1. CHECK FRONT AIR CONTROL (REAR WINDOW DEFOGGER SWITCH) CIRCUIT

Operate the rear window defogger switch.

Is the inspection result normal?

YES >> Inspection End.

NO >> GO TO 2

2. CHECK HARNESS CONTINUITY

1. Turn ignition switch OFF.
2. Disconnect BCM and front air control.
3. Check continuity between BCM connector and front air control connector.

BCM connector	Terminal	Front air control connector	Terminal	Continuity
M19	41	M176	11	Yes

4. Check continuity between BCM connector and ground.

BCM connector	Terminal	Ground	Continuity
M19	41	Ground	No

Is the inspection result normal?

YES >> Replace front air control. Refer to [VTL-8. "Removal and Installation"](#).

NO >> Repair or replace harness.

REAR WINDOW DEFOGGER RELAY

< DTC/CIRCUIT DIAGNOSIS >

REAR WINDOW DEFOGGER RELAY

Description

INFOID:0000000011560014

Power is supplied to the rear window defogger with BCM control.

Component Function Check

INFOID:0000000011560015

1. CHECK REAR WINDOW DEFOGGER RELAY POWER SUPPLY CIRCUIT

Check that an operation noise of rear window defogger relay (located in IPDM E/R) can be heard when turning the rear window defogger switch ON.

Is the inspection result normal?

- YES >> Rear window defogger relay power supply circuit is OK.
- NO >> Refer to [DEF-11, "Diagnosis Procedure"](#).

Diagnosis Procedure

INFOID:0000000011560016

Regarding Wiring Diagram information, refer to [DEF-32, "Wiring Diagram"](#).

1. CHECK FUSES

Check if any of the following fuses in the IPDM E/R are blown.

COMPONENT PARTS	AMPERE	FUSE NO.
IPDM E/R	15A	46
IPDM E/R	15A	47

Is the inspection result normal?

- YES >> GO TO 2
- NO >> If fuse is blown, be sure to eliminate cause of malfunction before installing new fuse.

2. CHECK REAR WINDOW DEFOGGER RELAY POWER SUPPLY CIRCUIT

1. Turn ignition switch ON.
2. Check voltage between IPDM E/R connector and ground.

(+)		(-)	Condition of rear window defogger switch	Voltage (V) (Approx.)
IPDM E/R connector	Terminal			
E124	60	Ground	ON	Battery voltage
			OFF	0

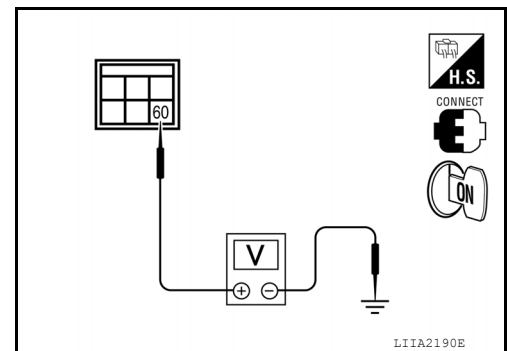

Is the inspection result normal?

- YES >> GO TO 3
- NO >> Replace IPDM E/R. Refer to [PCS-28, "Removal and Installation of IPDM E/R"](#).

3. CHECK INTERMITTENT INCIDENT

Check intermittent incident.
Refer to [GI-44, "Intermittent Incident"](#).

Is the inspection result normal?

- YES >> Check the following.
 - Battery power supply circuit
 - IPDM E/R
- NO >> Repair or replace the malfunctioning parts.

A
B
C
D
E
F
G
H
I
J
K
DEF
M
N
O
P

REAR WINDOW DEFOGGER SYSTEM

< DTC/CIRCUIT DIAGNOSIS >

REAR WINDOW DEFOGGER SYSTEM

Description

INFOID:000000011560017

Heats the heating wire with the power supply from the rear window defogger relay to prevent the rear window from fogging up.

Component Function Check

INFOID:000000011560018

1. CHECK REAR WINDOW DEFOGGER

Check that the heating wire of rear window defogger is heated when turning the rear window defogger switch ON.

Is the inspection result normal?

- YES >> Rear window defogger is OK.
- NO >> Refer to [DEF-12, "Diagnosis Procedure"](#).

Diagnosis Procedure

INFOID:000000011560019

Regarding Wiring Diagram information, refer to [DEF-32, "Wiring Diagram"](#).

1. CHECK FUSES

Check if any of the following fuses in IPDM E/R are blown.

COMPONENT PARTS	AMPERE	FUSE NO.
IPDM E/R	15A	46
	15A	47

Is the inspection result normal?

- YES >> GO TO 2
- NO >> If fuse is blown, be sure to eliminate cause of malfunction before installing new fuse.

2. CHECK REAR WINDOW DEFOGGER RELAY POWER SUPPLY CIRCUIT

1. Turn ignition switch ON.
2. Check voltage between IPDM E/R connector and ground.

(+)		(-)	Condition of rear window defogger switch	Voltage (V) (Approx.)
IPDM E/R connector	Terminal			
E124	60	Ground	ON	Battery voltage
			OFF	0

Is the inspection result normal?

- YES >> GO TO 3
- NO >> Replace IPDM E/R. Refer to [PCS-28, "Removal and Installation of IPDM E/R"](#).

3. CHECK REAR WINDOW DEFOGGER POWER CIRCUIT HARNESS CONTINUITY

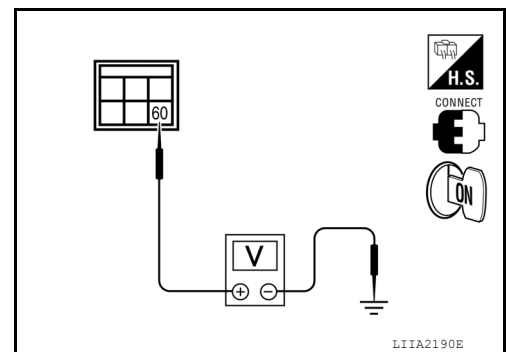

REAR WINDOW DEFOGGER SYSTEM

< DTC/CIRCUIT DIAGNOSIS >

1. Turn ignition switch OFF.
2. Disconnect IPDM E/R and rear window defogger cut-off relay.
3. Check continuity between IPDM E/R connector E124 (B) terminal 60 and rear window defogger cut-off relay connector M187 (A) terminals 2 and 3.

IPDM E/R connector	Terminal	Rear window defogger cut-off relay connector	Terminal	Continuity
B: E124	60	A: M187	2	Yes
			3	

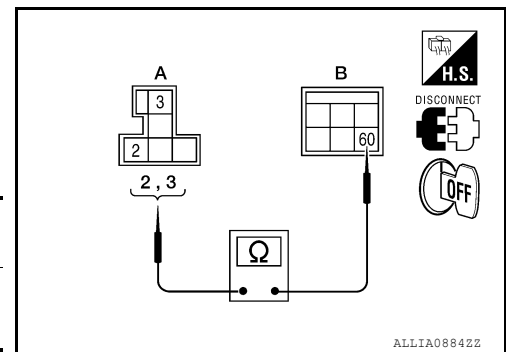

Is the inspection result normal?

- YES >> GO TO 4
 NO >> Repair or replace harness.

4. INSPECTION OF REAR POWER WINDOW DEFOGGER CUT-OFF RELAY

Check continuity between rear window defogger cut-off relay terminals 3 and 5.

Condition	Continuity
12V direct current supply between terminals 1 and 2	Yes
No current supply	No

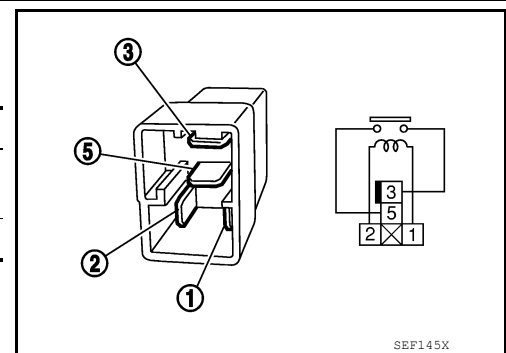

Is the inspection result normal?

- YES >> GO TO 5
 NO >> Replace rear window defogger cut-out relay.

5. CHECK REAR WINDOW DEFOGGER CUT-OFF RELAY GROUND CIRCUIT

1. Place rear power drop glass in the closed (UP) position.
2. Check continuity between rear window defogger cut-off relay connector M187 terminal 1 and ground.

1 - Ground : Continuity should exist.

Is the inspection result normal?

- YES >> GO TO 7
 NO >> GO TO 6

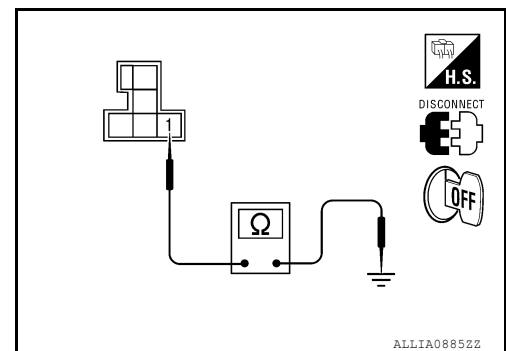

6. CHECK REAR POWER DROP GLASS MOTOR (DEF CUT-OFF SWITCH)

1. Disconnect rear power drop glass motor (def cut-off switch).
2. Check continuity between rear power drop glass motor (def cut-off switch) terminals 2 and 3.

Terminal	Rear power drop glass position	Continuity
2	Closed (UP)	Yes
	Open (DOWN) more than 18 mm	No

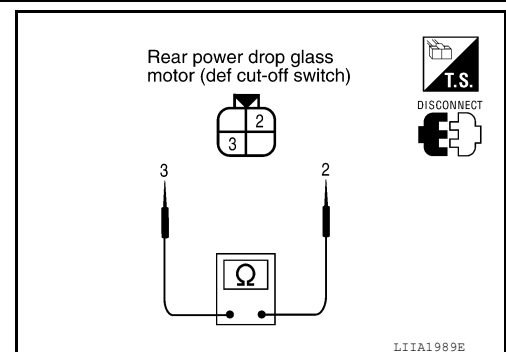

Is the inspection result normal?

- YES >> Repair or replace harness.
 NO >> Replace rear power drop glass motor (def cut-off switch).

7. CHECK POWER SUPPLY CIRCUIT

REAR WINDOW DEFOGGER SYSTEM

< DTC/CIRCUIT DIAGNOSIS >

1. Turn ignition switch ON.
2. Connect all disconnected connectors and rear window defogger cut-off relay.
3. Check voltage between rear window defogger connector and ground.

Terminals		(-)	Condition of rear window defogger switch	Voltage (V) (Approx.)
(+)				
Rear window defogger connector	Terminal			
B78	1	Ground	ON	Battery voltage
			OFF	0

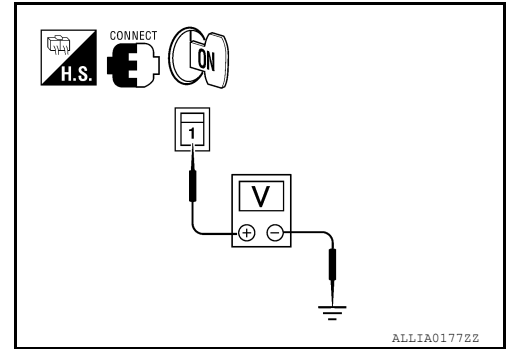

Is the inspection result normal?

- YES >> GO TO 8
 NO >> Repair or replace harness.

8. CHECK GROUND CIRCUIT

1. Turn ignition switch OFF.
2. Disconnect rear window defogger.
3. Check continuity between rear window defogger connector and ground.

Rear window defogger connector	Terminal	Ground	Continuity
B81	2		Yes

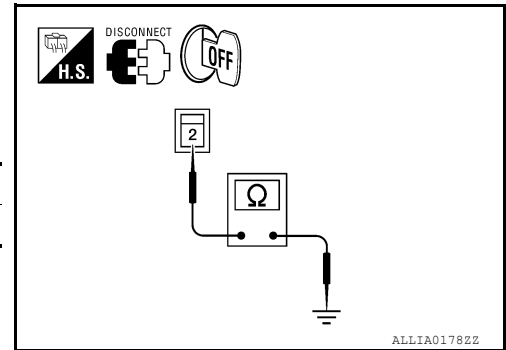

Is the inspection result normal?

- YES >> GO TO 9
 NO >> Repair or replace harness.

9. CHECK FILAMENT

Check filament.

Refer to [DEF-14, "Component Inspection"](#).

Is the inspection result normal?

- YES >> Refer to [GI-44, "Intermittent Incident"](#).
 NO >> Repair filament. Refer to [DEF-48, "Filament Repair"](#).

Component Inspection

INFOID:000000011560020

1. CHECK FILAMENT

Check the filament for damage or open circuits.

Refer to [DEF-48, "Filament Check"](#).

Is the inspection result normal?

- YES >> Inspection End.
 NO >> Repair filament. Refer to [DEF-48, "Filament Repair"](#).

DOOR MIRROR DEFOGGER LH

< DTC/CIRCUIT DIAGNOSIS >

DOOR MIRROR DEFOGGER LH

Description

INFOID:000000011560021

Heats the heating wire with the power supply from the heated mirror relay to prevent the door mirror from fogging up.

Component Function Check

INFOID:000000011560022

1. CHECK DOOR MIRROR DEFOGGER LH

Check that heating wire of door mirror defogger LH is heated when turning the rear window defogger switch ON.

Is the inspection result normal?

- YES >> Door mirror defogger is OK.
- NO >> Refer to [DEF-15. "Diagnosis Procedure"](#).

Diagnosis Procedure

INFOID:000000011560023

Regarding Wiring Diagram information, refer to [DEF-32. "Wiring Diagram"](#).

1. CHECK POWER SUPPLY

Check if the following fuse in the IPDM E/R is blown.

COMPONENT PARTS	AMPERE	FUSE NO.
IPDM E/R	15A	43

Is the inspection result normal?

- YES >> GO TO 2
- NO >> If fuse is blown, be sure to eliminate cause of malfunction before installing new fuse.

2. CHECK DOOR MIRROR DEFOGGER POWER SUPPLY CIRCUIT 1

1. Turn ignition switch ON.
2. Check voltage between IPDM E/R connector and ground.

Connector	Terminal		Condition	Voltage (V) (Approx.)
	(+)	(-)		
E120	23	Ground	Rear window defogger switch ON	Battery voltage
			Rear window defogger switch OFF	0

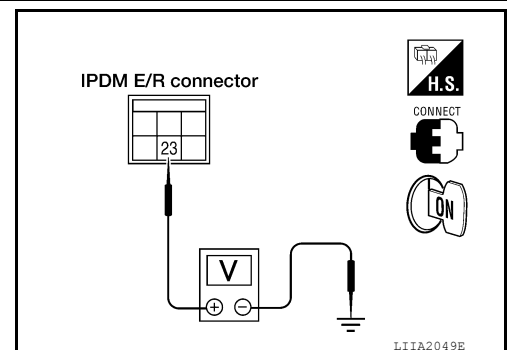

Is the inspection result normal?

- YES >> GO TO 3 (with automatic drive positioner)
- YES >> GO TO 5 (without automatic drive positioner)
- NO >> Replace IPDM E/R. Refer to [PCS-28. "Removal and Installation of IPDM E/R"](#).

3. CHECK DOOR MIRROR DEFOGGER POWER SUPPLY CIRCUIT 2

1. Turn ignition switch OFF.
2. Disconnect door mirror LH.
3. Turn ignition switch ON.
4. Check voltage between door mirror LH connector and ground.

Connector	Terminal		Condition	Voltage (V) (Approx.)
	(+)	(-)		

DOOR MIRROR DEFOGGER LH

< DTC/CIRCUIT DIAGNOSIS >

D4	10	Ground	Rear window defogger switch ON	Battery voltage
			Rear window defogger switch OFF	0

Is the inspection result normal?

- YES >> GO TO 4
- NO >> Repair or replace harness.

4. CHECK DOOR MIRROR DEFOGGER GROUND CIRCUIT

Check continuity between door mirror LH connector D4 terminal 11 and ground.

11 - Ground : Continuity should exist.

Is the inspection result normal?

- YES >> GO TO 7
- NO >> Repair or replace harness.

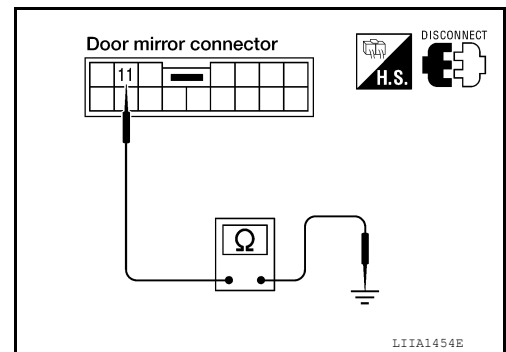

5. CHECK DOOR MIRROR DEFOGGER POWER SUPPLY CIRCUIT 2

1. Turn ignition switch OFF.
2. Disconnect door mirror LH.
3. Turn ignition switch ON.
4. Check voltage between door mirror LH connector and ground.

Connector	Terminal		Condition	Voltage (V) (Approx.)
	(+)	(-)		
D6	4	Ground	Rear window defogger switch ON	Battery voltage
			Rear window defogger switch OFF	0

Is the inspection result normal?

- YES >> GO TO 6
- NO >> Repair or replace harness.

6. CHECK DOOR MIRROR DEFOGGER GROUND CIRCUIT

Check continuity between door mirror LH connector D6 terminal 6 and ground.

6 - Ground : Continuity should exist.

Is the inspection result normal?

- YES >> GO TO 7
- NO >> Repair or replace harness.

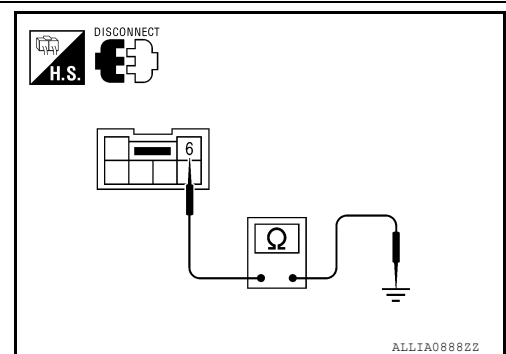

7. CHECK DOOR MIRROR DEFOGGER LH

Check door mirror defogger LH.

Refer to [DEF-17. "Component Inspection \(With Automatic Drive Positioner\)".](#)

Refer to [DEF-17. "Component Inspection \(Without Automatic Drive Positioner\)".](#)

Is the inspection result normal?

- YES >> GO TO 8
- NO >> Replace door mirror. Refer to [MIR-18. "Door Mirror Assembly".](#)

8. CHECK INTERMITTENT INCIDENT

Check intermittent incident.

DOOR MIRROR DEFOGGER LH

< DTC/CIRCUIT DIAGNOSIS >

Refer to [GI-44, "Intermittent Incident"](#).

Is the inspection result normal?

- YES >> Check the following.
- Battery power supply circuit
 - IPDM E/R

NO >> Repair or replace the malfunctioning parts.

Component Inspection (With Automatic Drive Positioner)

INFOID:000000011560024

1. CHECK DOOR MIRROR DEFOGGER

Check continuity between door mirror LH terminals 10 and 11.

10 - 11 : **Continuity should exist.**

Is the inspection result normal?

- YES >> Check the condition of the harness and the connector.
- NO >> Replace malfunctioning door mirror LH. Refer to [MIR-18, "Door Mirror Assembly"](#).

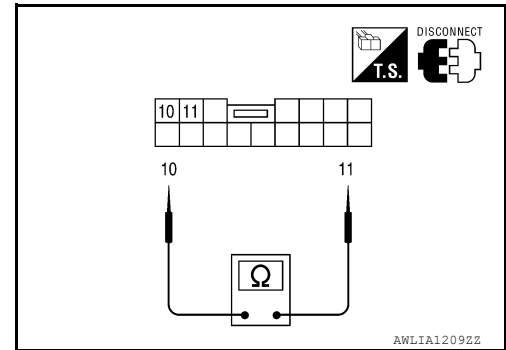

Component Inspection (Without Automatic Drive Positioner)

INFOID:000000011560025

1. CHECK DOOR MIRROR DEFOGGER

Check continuity between door mirror LH terminals 4 and 6.

4 - 6 : **Continuity should exist.**

Is the inspection result normal?

- YES >> Check the condition of the harness and the connector.
- NO >> Replace malfunctioning door mirror LH. Refer to [MIR-18, "Door Mirror Assembly"](#).

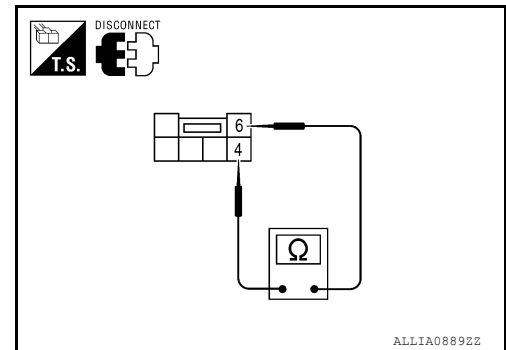

A
B
C
D
E
F
G
H
I
J
K
DEF
M
N
O
P

DOOR MIRROR DEFOGGER RH

< DTC/CIRCUIT DIAGNOSIS >

DOOR MIRROR DEFOGGER RH

Description

INFOID:000000011560026

Heats the heating wire with the power supply from the heated mirror relay to prevent the door mirror from fogging up.

Component Function Check

INFOID:000000011560027

1. CHECK DOOR MIRROR DEFOGGER RH

Check that the heating wire of door mirror defogger RH is heated when turning the rear window defogger switch ON.

Is the inspection result normal?

- YES >> Door mirror defogger RH is OK.
- NO >> Refer to [DEF-18, "Diagnosis Procedure"](#).

Diagnosis Procedure

INFOID:000000011560028

Regarding Wiring Diagram information, refer to [DEF-32, "Wiring Diagram"](#).

1. CHECK POWER SUPPLY

Check if the following fuse in the IPDM E/R is blown.

COMPONENT PARTS	AMPERE	FUSE NO.
IPDM E/R	15A	43

Is the inspection result normal?

- YES >> GO TO 2
- NO >> If fuse is blown, be sure to eliminate cause of malfunction before installing new fuse.

2. CHECK DOOR MIRROR DEFOGGER POWER SUPPLY CIRCUIT 1

1. Turn ignition switch ON.
2. Check voltage between IPDM E/R connector and ground.

Connector	Terminal		Condition	Voltage (V) (Approx.)
	(+)	(-)		
E120	23	Ground	Rear window defogger switch ON	Battery voltage
			Rear window defogger switch OFF	0

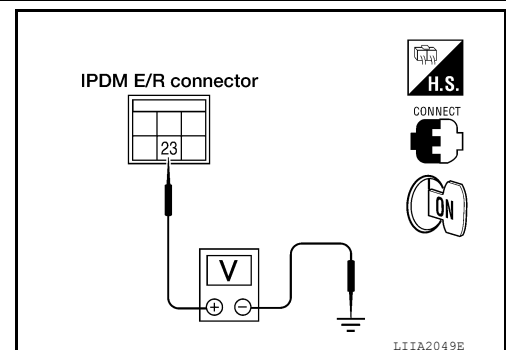

Is the inspection result normal?

- YES >> GO TO 3 (with automatic drive positioner)
- YES >> GO TO 5 (without automatic drive positioner)
- NO >> Replace IPDM E/R. Refer to [PCS-28, "Removal and Installation of IPDM E/R"](#).

3. CHECK DOOR MIRROR DEFOGGER POWER SUPPLY CIRCUIT 2

1. Turn ignition switch OFF.
2. Disconnect door mirror RH.
3. Turn ignition switch ON.
4. Check voltage between door mirror RH connector and ground.

Connector	Terminal		Condition	Voltage (V) (Approx.)
	(+)	(-)		

DOOR MIRROR DEFOGGER RH

< DTC/CIRCUIT DIAGNOSIS >

D107	10	Ground	Rear window defogger switch ON	Battery voltage
			Rear window defogger switch OFF	0

Is the inspection result normal?

- YES >> GO TO 4
- NO >> Repair or replace harness.

4. CHECK DOOR MIRROR DEFOGGER GROUND CIRCUIT

Check continuity between door mirror RH connector D107 terminal 11 and ground.

11 - Ground : Continuity should exist.

Is the inspection result normal?

- YES >> GO TO 7
- NO >> Repair or replace harness.

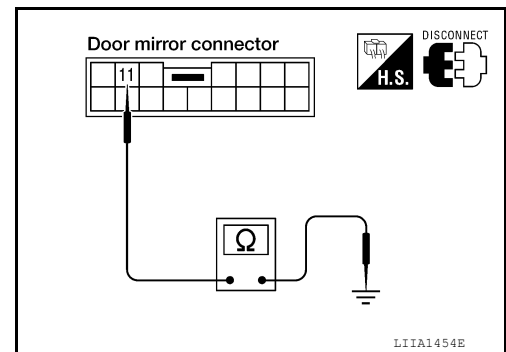

5. CHECK DOOR MIRROR DEFOGGER POWER SUPPLY CIRCUIT 2

1. Turn ignition switch OFF.
2. Disconnect door mirror RH.
3. Turn ignition switch ON.
4. Check voltage between door mirror RH connector and ground.

Connector	Terminal		Condition	Voltage (V) (Approx.)
	(+)	(-)		
D106	4	Ground	Rear window defogger switch ON	Battery voltage
			Rear window defogger switch OFF	0

Is the inspection result normal?

- YES >> GO TO 6
- NO >> Repair or replace harness.

6. CHECK DOOR MIRROR DEFOGGER GROUND CIRCUIT

Check continuity between door mirror RH connector D106 terminal 6 and ground.

6 - Ground : Continuity should exist.

Is the inspection result normal?

- YES >> GO TO 7
- NO >> Repair or replace harness.

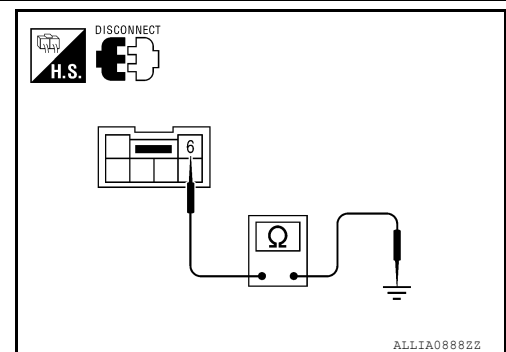

7. CHECK DOOR MIRROR DEFOGGER RH

Check door mirror defogger RH.

Refer to [DEF-20. "Component Inspection \(With Automatic Drive Positioner\)".](#)

Refer to [DEF-20. "Component Inspection \(Without Automatic Drive Positioner\)".](#)

Is the inspection result normal?

- YES >> GO TO 8
- NO >> Replace door mirror. Refer to [MIR-18. "Door Mirror Assembly".](#)

8. CHECK INTERMITTENT INCIDENT

Check intermittent incident.

DOOR MIRROR DEFOGGER RH

< DTC/CIRCUIT DIAGNOSIS >

Refer to [GI-44, "Intermittent Incident"](#).

Is the inspection result normal?

- YES >> Check the following.
- Battery power supply circuit
 - IPDM E/R

NO >> Repair or replace the malfunctioning parts.

Component Inspection (With Automatic Drive Positioner)

INFOID:000000011560029

1. CHECK DOOR MIRROR DEFOGGER

Check continuity between door mirror RH terminals 10 and 11.

10 - 11 : Continuity should exist.

Is the inspection result normal?

- YES >> Check the condition of the harness and the connector.
NO >> Replace malfunctioning door mirror RH. Refer to [MIR-18, "Door Mirror Assembly"](#).

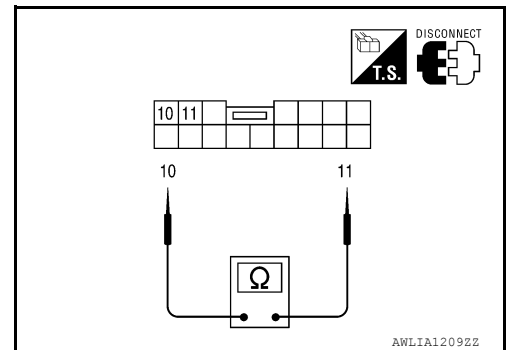

Component Inspection (Without Automatic Drive Positioner)

INFOID:000000011560030

1. CHECK DOOR MIRROR DEFOGGER

Check continuity between door mirror RH terminals 4 and 6.

4 - 6 : Continuity should exist.

Is the inspection result normal?

- YES >> Check the condition of the harness and the connector.
NO >> Replace malfunctioning door mirror RH. Refer to [MIR-18, "Door Mirror Assembly"](#).

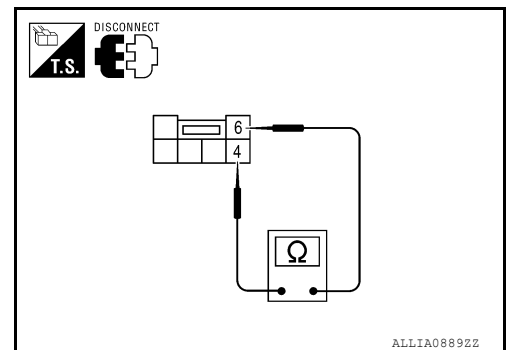

BCM (BODY CONTROL MODULE)

< ECU DIAGNOSIS INFORMATION >

ECU DIAGNOSIS INFORMATION

BCM (BODY CONTROL MODULE)

Reference Value

INFOID:0000000011875468

NOTE:

The Signal Tech II Tool [– (J-50190)] can be used to perform the following functions. Refer to the Signal Tech II User Guide for additional information:

- Activate and display TPMS transmitter IDs
- Display tire pressure reported by the TPMS transmitter
- Read TPMS DTCs
- Register TPMS transmitter IDs
- Test remote keyless entry keyfob relative signal strength

VALUES ON THE DIAGNOSIS TOOL

Monitor Item	Condition	Value/Status
ACC ON SW	Ignition switch OFF or ON	Off
	Ignition switch ACC	On
AIR COND SW	A/C switch OFF	Off
	A/C switch ON	On
AIR PRESS FL	Front left tire air pressure value	kPa, kg/cm ² , psi
AIR PRESS FR	Front right tire air pressure value	kPa, kg/cm ² , psi
AIR PRESS RL	Rear left tire air pressure value	kPa, kg/cm ² , psi
AIR PRESS RR	Rear right tire air pressure value	kPa, kg/cm ² , psi
AUTO LIGHT SW	Lighting switch OFF	Off
	Lighting switch AUTO	On
BRAKE SW	Brake pedal released	Off
	Brake pedal applied	On
BUCKLE SW	Seat belt buckle unfastened	Off
	Seat belt buckle fastened	On
BUZZER	Buzzer in combination meter OFF	Off
	Buzzer in combination meter ON	On
CARGO LAMP SW	Cargo lamp switch OFF	Off
	Cargo lamp switch ON	On
CDL LOCK SW	Door lock/unlock switch does not operate	Off
	Press door lock/unlock switch to the LOCK side	On
CDL UNLOCK SW	Door lock/unlock switch does not operate	Off
	Press door lock/unlock switch to the UNLOCK side	On
DOOR SW-AS	Front door RH closed	Off
	Front door RH opened	On
DOOR SW-DR	Front door LH closed	Off
	Front door LH opened	On
DOOR SW-RL	Rear door LH closed	Off
	Rear door LH opened	On
DOOR SW-RR	Rear door RH closed	Off
	Rear door RH opened	On

BCM (BODY CONTROL MODULE)

< ECU DIAGNOSIS INFORMATION >

Monitor Item	Condition	Value/Status
FAN ON SIG	Blower motor fan switch OFF	Off
	Blower motor fan switch ON	On
FR FOG SW	Front fog lamp switch OFF	Off
	Front fog lamp switch ON	On
FR WASHER SW	Front washer switch OFF	Off
	Front washer switch ON	On
FR WIPER LOW	Front wiper switch OFF	Off
	Front wiper switch LO	On
FR WIPER HI	Front wiper switch OFF	Off
	Front wiper switch HI	On
FR WIPER INT	Front wiper switch OFF	Off
	Front wiper switch INT	On
FR WIPER STOP	Any position other than front wiper stop position	Off
	Front wiper stop position	On
HAZARD SW	When hazard switch is not pressed	Off
	When hazard switch is pressed	On
HEAD LAMP SW1	Headlamp switch OFF	Off
	Headlamp switch 1st	On
HEAD LAMP SW2	Headlamp switch OFF	Off
	Headlamp switch 1st	On
HI BEAM SW	High beam switch OFF	Off
	High beam switch HI	On
ID REGST FL1	ID registration of front left tire incomplete	YET
	ID registration of front left tire complete	DONE
ID REGST FR1	ID registration of front right tire incomplete	YET
	ID registration of front right tire complete	DONE
ID REGST RL1	ID registration of rear left tire incomplete	YET
	ID registration of rear left tire complete	DONE
ID REGST RR1	ID registration of rear right tire incomplete	YET
	ID registration of rear right tire complete	DONE
IGN ON SW	Ignition switch OFF or ACC	Off
	Ignition switch ON	On
IGN SW CAN	Ignition switch OFF or ACC	Off
	Ignition switch ON	On
INT VOLUME	Wiper intermittent dial is in a dial position 1 - 7	1 - 7
KEY CYL LK-SW	Door key cylinder LOCK position	Off
	Door key cylinder other than LOCK position	On
KEY CYL UN-SW	Door key cylinder UNLOCK position	Off
	Door key cylinder other than UNLOCK position	On
KEY ON SW	Mechanical key is removed from key cylinder	Off
	Mechanical key is inserted to key cylinder	On
KEYLESS LOCK	LOCK button of key fob is not pressed	Off
	LOCK button of key fob is pressed	On

BCM (BODY CONTROL MODULE)

< ECU DIAGNOSIS INFORMATION >

Monitor Item	Condition	Value/Status	
KEYLESS PANIC	PANIC button of key fob is not pressed	Off	A
	PANIC button of key fob is pressed	On	
KEYLESS UNLOCK	UNLOCK button of key fob is not pressed	Off	B
	UNLOCK button of key fob is pressed	On	
LIGHT SW 1ST	Lighting switch OFF	Off	C
	Lighting switch 1st	On	
OIL PRESS SW	<ul style="list-style-type: none"> • Ignition switch OFF or ACC • Engine running 	Off	D
	Ignition switch ON	On	
OPTICAL SENSOR	Bright outside of the vehicle	Close to 5V	E
	Dark outside of the vehicle	Close to 0V	
PASSING SW	Other than lighting switch PASS	Off	F
	Lighting switch PASS	On	
REAR DEF SW	Rear window defogger switch OFF	Off	G
	Rear window defogger switch ON	On	
TURN SIGNAL L	Turn signal switch OFF	Off	H
	Turn signal switch LH	On	
TURN SIGNAL R	Turn signal switch OFF	Off	I
	Turn signal switch RH	On	
VEHICLE SPEED	While driving	Equivalent to speedometer reading	J
WARNING LAMP	Low tire pressure warning lamp in combination meter OFF	Off	K
	Low tire pressure warning lamp in combination meter ON	On	

DEF

M

N

O

P

BCM (BODY CONTROL MODULE)

< ECU DIAGNOSIS INFORMATION >

Terminal Layout

INFOID:000000011875469

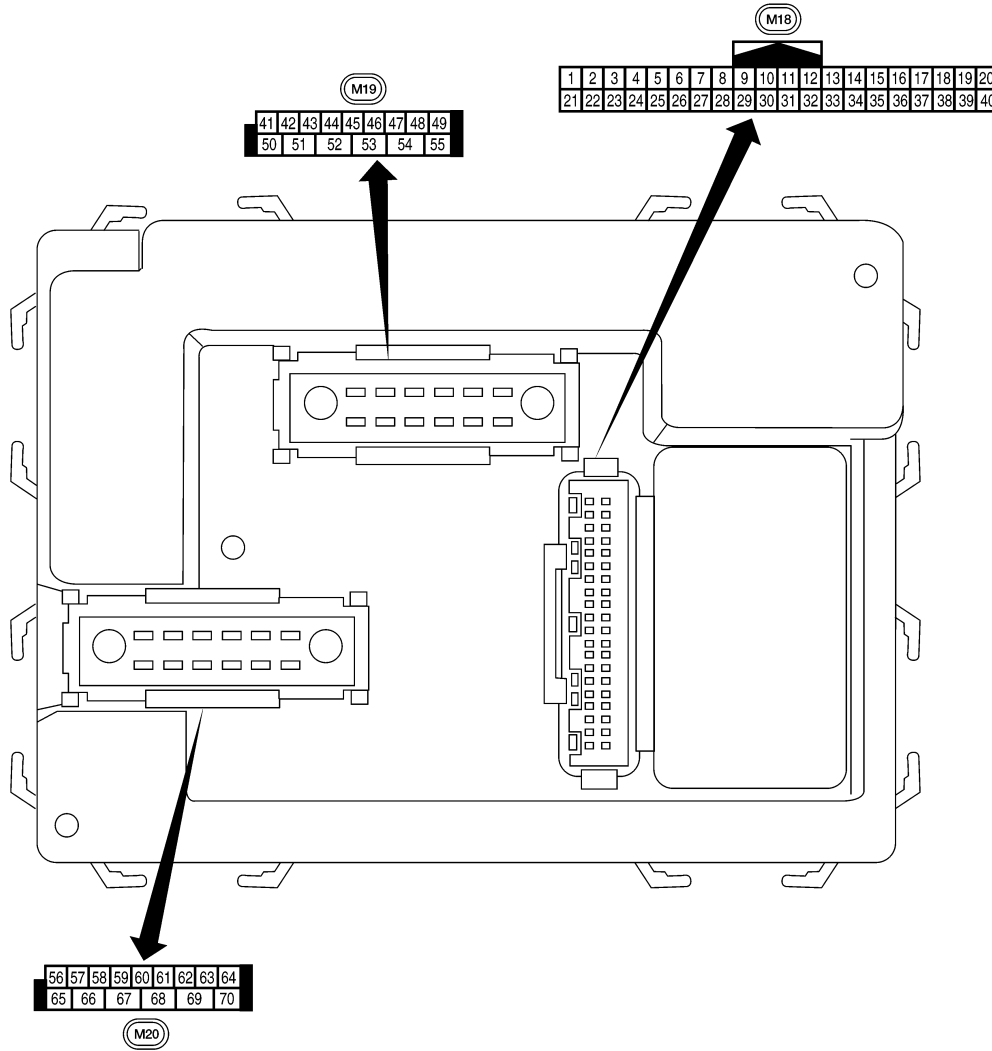



AWMIA15422Z

Physical Values

INFOID:000000011875470

BCM (BODY CONTROL MODULE)

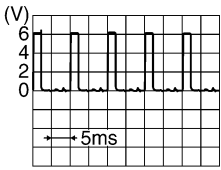
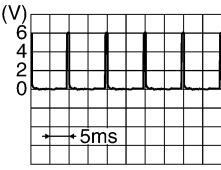
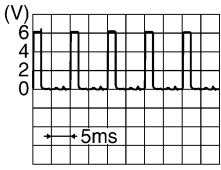
< ECU DIAGNOSIS INFORMATION >

Terminal	Wire color	Signal name	Signal input/output	Measuring condition		Reference value or waveform (Approx.)
				Ignition switch	Operation or condition	
1	BR/W	Key ring output	Output	OFF	ON (driver door open)	0V
					OFF (driver door closed)	Battery voltage
2	SB	Combination switch input 5	Input	ON	Lighting, turn, wiper OFF Wiper dial position 4	 SKIA5291E
3	G/Y	Combination switch input 4	Input	ON	Lighting, turn, wiper OFF Wiper dial position 4	 SKIA5292E
4	Y	Combination switch input 3	Input	ON	Lighting, turn, wiper OFF Wiper dial position 4	 SKIA5291E
5	G/B	Combination switch input 2	Input	ON	Lighting, turn, wiper OFF Wiper dial position 4	 SKIA5292E
6	V	Combination switch input 1				
9	R/G	Brake switch	Input	ON	Brake pedal depressed	Battery voltage
					Brake pedal released	0V
11	O	Ignition switch (ACC or ON)	Input	ACC or ON	Ignition switch ACC or ON	Battery voltage
12	R/L	Front door switch RH (All)	Input	OFF	ON (open)	0V
		Rear door switch lower RH (King Cab)			OFF (closed)	Battery voltage
		Rear door switch upper RH (King Cab)				
13	GR	Rear door switch RH (Crew Cab)	Input	OFF	ON (open)	0V
					OFF (closed)	Battery voltage
15	L/W	Tire pressure warning check connector	Input	OFF	—	5V
18	P	Remote keyless entry receiver and optical sensor (ground)	Output	OFF	—	0V

A
B
C
D
E
F
G
H
I
J
K
DEF
M
N
O
P

BCM (BODY CONTROL MODULE)

< ECU DIAGNOSIS INFORMATION >

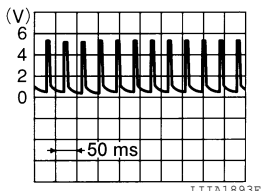
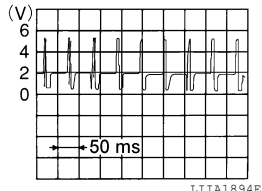
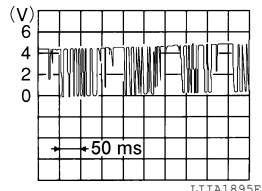
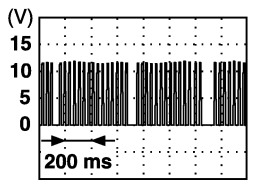
Terminal	Wire color	Signal name	Signal input/output	Measuring condition		Reference value or waveform (Approx.)
				Ignition switch	Operation or condition	
19	V/W	Remote keyless entry receiver (power supply)	Output	OFF	Ignition switch OFF	 <p style="text-align: right; font-size: small;">LITA1895E</p>
20	G/W	Remote keyless entry receiver (signal)	Input	OFF	Stand-by (keyfob buttons released)	 <p style="text-align: right; font-size: small;">LITA1894E</p>
					When remote keyless entry receiver receives signal from keyfob (keyfob buttons pressed)	 <p style="text-align: right; font-size: small;">LITA1895E</p>
21	G	NATS antenna amp.	Input	OFF → ON	Ignition switch (OFF → ON)	Just after turning ignition switch ON: Pointer of tester should move for approx. 1 second, then return to battery voltage.
22	G	BUS	—	—	Ignition switch ON or power window timer operates	 <p style="text-align: right; font-size: small;">PIIA2344E</p>
23	G/O	Security indicator lamp	Output	OFF	Goes OFF → illuminates (Every 2.4 seconds)	Battery voltage → 0V
25	BR	NATS antenna amp.	Input	OFF → ON	Ignition switch (OFF → ON)	Just after turning ignition switch ON: Pointer of tester should move for approx. 1 second, then return to battery voltage.
27	W/R	Compressor ON signal	Input	ON	A/C switch OFF	5V
					A/C switch ON	0V
28	L/R	Front blower monitor	Input	ON	Front blower motor OFF	Battery voltage
					Front blower motor ON	0V
29	W/B	Hazard switch	Input	OFF	ON	0V
					OFF	5V
31	P/L	Cargo lamp switch	Input	OFF	Cargo lamp switch ON	0
					Cargo lamp switch OFF	Battery voltage

BCM (BODY CONTROL MODULE)

< ECU DIAGNOSIS INFORMATION >

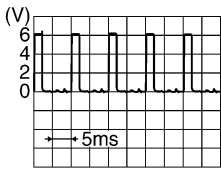
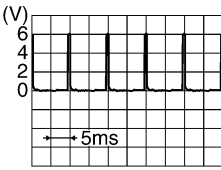
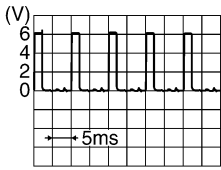
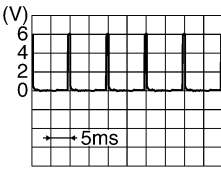
Terminal	Wire color	Signal name	Signal input/output	Measuring condition		Reference value or waveform (Approx.)
				Ignition switch	Operation or condition	
32	R/G	Combination switch output 5	Output	ON	Lighting, turn, wiper OFF Wiper dial position 4	 SKIA5291E
33	R/Y	Combination switch output 4	Output	ON	Lighting, turn, wiper OFF Wiper dial position 4	 SKIA5292E
34	L	Combination switch output 3	Output	ON	Lighting, turn, wiper OFF Wiper dial position 4	 SKIA5291E
35	O/B	Combination switch output 2	Output	ON	Lighting, turn, wiper OFF Wiper dial position 4	 SKIA5292E
36	R/W	Combination switch output 1				
37	B/R	Key switch and key lock solenoid	Input	OFF	Key inserted	Battery voltage
					Key removed	0V
38	W/L	Ignition switch (ON)	Input	ON	—	Battery voltage
39	L	CAN-H	—	—	—	—
40	P	CAN-L	—	—	—	—
41	Y/B	Rear defogger switch	Input	ON	Rear defogger switch ON	0V
					Rear defogger switch OFF	5V
47	SB	Front door switch LH (All)	Input	OFF	ON (open)	0V
		Rear door switch lower LH (King Cab)				
		Rear door switch upper LH (King Cab)				
48	R/Y	Rear door switch LH (Crew Cab)	Input	OFF	ON (open)	0V
					OFF (closed)	Battery voltage
50	R/Y	Cargo bed lamp control	Output	OFF	Cargo lamp switch (ON)	0V
					Cargo lamp switch (OFF)	Battery voltage

BCM (BODY CONTROL MODULE)

< ECU DIAGNOSIS INFORMATION >

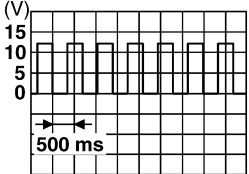
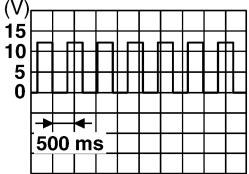
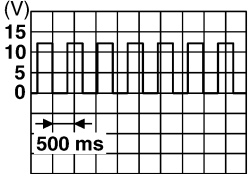
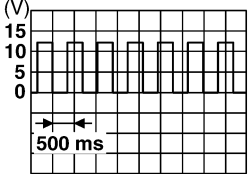
Terminal	Wire color	Signal name	Signal input/output	Measuring condition		Reference value or waveform (Approx.)	
				Ignition switch	Operation or condition		
51	Y/B	Trailer turn signal (right)	Output	ON	Turn right ON	 <p style="text-align: right; font-size: small;">SKIA3009J</p>	
52	G/B	Trailer turn signal (left)	Output	ON	Turn left ON	 <p style="text-align: right; font-size: small;">SKIA3009J</p>	
56	R/G	Battery saver output	Output	OFF	15 minutes after ignition switch is turned OFF	0V	
				ON	—	Battery voltage	
57	Y/R	Battery power supply	Input	OFF	—	Battery voltage	
58	W/R	Optical sensor	Input	ON	When optical sensor is illuminated	3.1V or more	
					When optical sensor is not illuminated	0.6V or less	
59	G	Front door lock assembly LH actuator (unlock)	Output	OFF	OFF (neutral)	0V	
					ON (unlock)	Battery voltage	
60	G/B	Turn signal (left)	Output	ON	Turn left ON	 <p style="text-align: right; font-size: small;">SKIA3009J</p>	
61	G/Y	Turn signal (right)	Output	ON	Turn right ON	 <p style="text-align: right; font-size: small;">SKIA3009J</p>	
63	L	Interior room/map lamp	Output	OFF	Any door switch	ON (open)	0V
					OFF (closed)	Battery voltage	
65	V	All door lock actuators (lock)	Output	OFF	OFF (neutral)	0V	
					ON (lock)	Battery voltage	
66	G/Y	Front door lock actuator RH and rear door lock actuators LH/RH (unlock)	Output	OFF	OFF (neutral)	0V	
					ON (unlock)	Battery voltage	
67	B	Ground	Input	ON	—	0V	

BCM (BODY CONTROL MODULE)

< ECU DIAGNOSIS INFORMATION >

Terminal	Wire color	Signal name	Signal input/output	Measuring condition		Reference value or waveform (Approx.)
				Ignition switch	Operation or condition	
68	W/L	Power window power supply (RAP)	Output	—	Ignition switch ON	Battery voltage
					Within 45 seconds after ignition switch OFF	Battery voltage
					More than 45 seconds after ignition switch OFF	0V
					When front door LH or RH is open or power window timer operates	0V
69	W/R	Power window power supply	Output	—	—	Battery voltage
70	W/B	Battery power supply	Input	OFF	—	Battery voltage

Fail Safe

INFOID:0000000011875471

Fail-safe index

BCM performs fail-safe control when any DTC listed below is detected.

Display contents of CONSULT	Fail-safe	Cancellation
U1000: CAN COMM CIRCUIT	Inhibit engine cranking	When the BCM re-establishes communication with the other modules.

DTC Inspection Priority Chart

INFOID:0000000011875472

If some DTCs are displayed at the same time, perform inspections one by one based on the following priority chart:

Priority	DTC
1	<ul style="list-style-type: none"> U1000: CAN COMM CIRCUIT
2	<ul style="list-style-type: none"> B2190: NATS ANTENNA AMP B2191: DIFFERENCE OF KEY B2192: ID DISCORD BCM-ECM B2193: CHAIN OF BCM-ECM

DEF

BCM (BODY CONTROL MODULE)

< ECU DIAGNOSIS INFORMATION >

Priority	DTC
3	<ul style="list-style-type: none"> • C1729: VHCL SPEED SIG ERR • C1735: IGNITION SIGNAL
4	<ul style="list-style-type: none"> • C1704: LOW PRESSURE FL • C1705: LOW PRESSURE FR • C1706: LOW PRESSURE RR • C1707: LOW PRESSURE RL • C1708: [NO DATA] FL • C1709: [NO DATA] FR • C1710: [NO DATA] RR • C1711: [NO DATA] RL • C1712: [CHECKSUM ERR] FL • C1713: [CHECKSUM ERR] FR • C1714: [CHECKSUM ERR] RR • C1715: [CHECKSUM ERR] RL • C1716: [PRESSDATA ERR] FL • C1717: [PRESSDATA ERR] FR • C1718: [PRESSDATA ERR] RR • C1719: [PRESSDATA ERR] RL • C1720: [CODE ERR] FL • C1721: [CODE ERR] FR • C1722: [CODE ERR] RR • C1723: [CODE ERR] RL • C1724: [BATT VOLT LOW] FL • C1725: [BATT VOLT LOW] FR • C1726: [BATT VOLT LOW] RR • C1727: [BATT VOLT LOW] RL

DTC Index

INFOID:000000011875473

NOTE:

Details of time display

- CRNT: Displays when there is a malfunction now or after returning to the normal condition until turning ignition switch OFF → ON again.
- 1 - 39: Displayed if any previous malfunction is present when current condition is normal. It increases like 1 → 2 → 3...38 → 39 after returning to the normal condition whenever ignition switch OFF → ON. The counter remains at 39 even if the number of cycles exceeds it. It is counted from 1 again when turning ignition switch OFF → ON after returning to the normal condition if the malfunction is detected again.

CONSULT display	Fail-safe	Tire pressure monitor warning lamp ON	Reference page
No DTC is detected. further testing may be required.	—	—	—
U1000: CAN COMM CIRCUIT	—	—	BCS-30
B2190: NATS ANTENA AMP	—	—	SEC-18
B2191: DIFFERENCE OF KEY	—	—	SEC-21
B2192: ID DISCORD BCM-ECM	—	—	SEC-22
B2193: CHAIN OF BCM-ECM	—	—	SEC-24
C1708: [NO DATA] FL	—	—	WT-15
C1709: [NO DATA] FR	—	—	WT-15
C1710: [NO DATA] RR	—	—	WT-15
C1711: [NO DATA] RL	—	—	WT-15
C1712: [CHECKSUM ERR] FL	—	—	WT-17
C1713: [CHECKSUM ERR] FR	—	—	WT-17
C1714: [CHECKSUM ERR] RR	—	—	WT-17
C1715: [CHECKSUM ERR] RL	—	—	WT-17

BCM (BODY CONTROL MODULE)

< ECU DIAGNOSIS INFORMATION >

CONSULT display	Fail-safe	Tire pressure monitor warning lamp ON	Reference page
C1716: [PRESSDATA ERR] FL	—	—	WT-19
C1717: [PRESSDATA ERR] FR	—	—	WT-19
C1718: [PRESSDATA ERR] RR	—	—	WT-19
C1719: [PRESSDATA ERR] RL	—	—	WT-19
C1720: [CODE ERR] FL	—	—	WT-17
C1721: [CODE ERR] FR	—	—	WT-17
C1722: [CODE ERR] RR	—	—	WT-17
C1723: [CODE ERR] RL	—	—	WT-17
C1724: [BATT VOLT LOW] FL	—	—	WT-17
C1725: [BATT VOLT LOW] FR	—	—	WT-17
C1726: [BATT VOLT LOW] RR	—	—	WT-17
C1727: [BATT VOLT LOW] RL	—	—	WT-17
C1729: VHCL SPEED SIG ERR	—	—	WT-21
C1735: IGNITION SIGNAL	—	—	WT-23

A
B
C
D
E
F
G
H
I
J
K
DEF
M
N
O
P

REAR WINDOW DEFOGGER

< WIRING DIAGRAM >

WIRING DIAGRAM

REAR WINDOW DEFOGGER

Wiring Diagram

INFOID:000000011560034

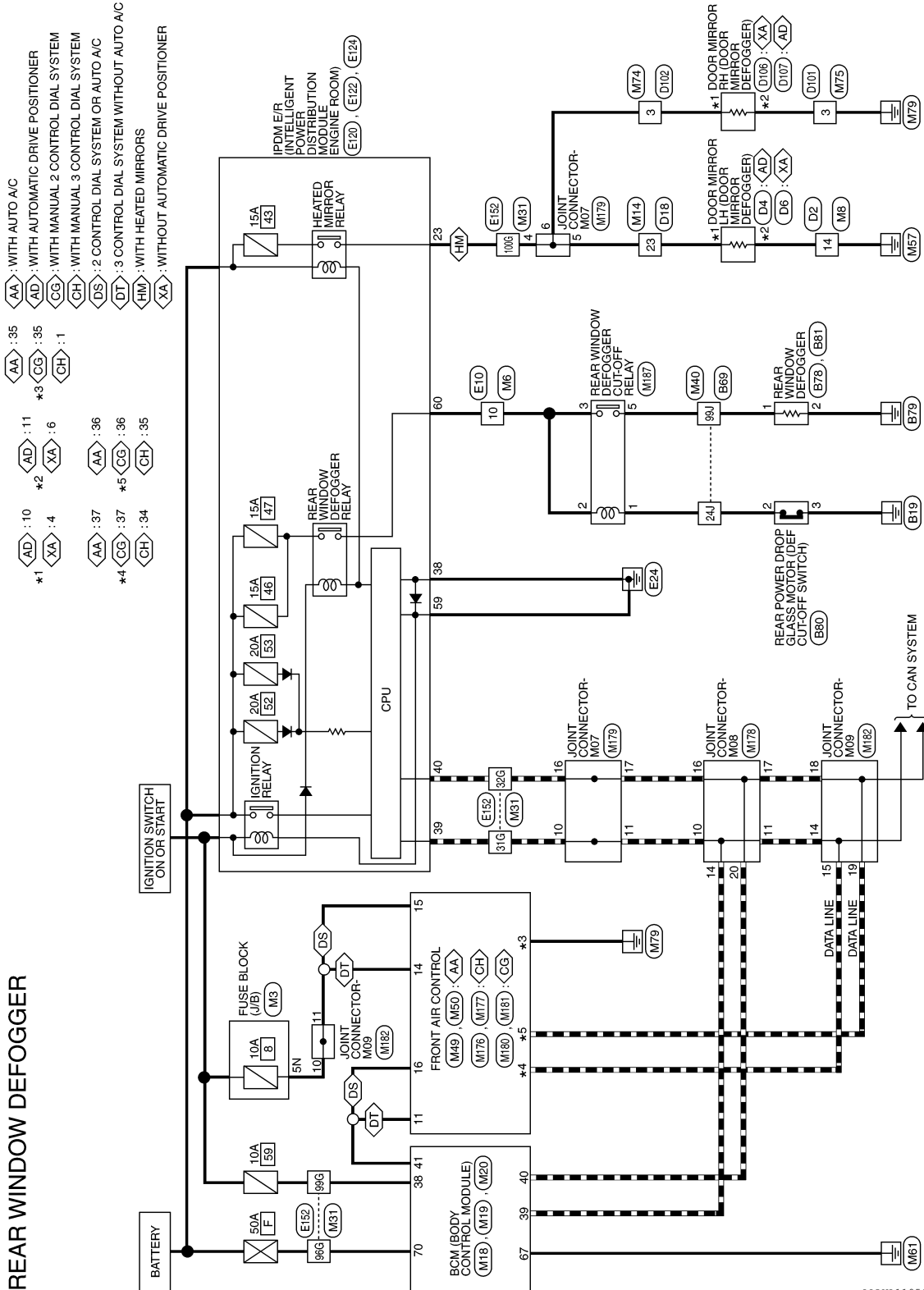

AALW1195GB

REAR WINDOW DEFOGGER

< WIRING DIAGRAM >

REAR WINDOW DEFOGGER CONNECTORS

Connector No.	M3
Connector Name	FUSE BLOCK (J/B)
Connector Color	WHITE

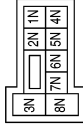

Terminal No.	5N	Color of Wire	Y/G	Signal Name	-
--------------	----	---------------	-----	-------------	---

Connector No.	M6
Connector Name	WIRE TO WIRE
Connector Color	WHITE

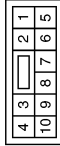

Terminal No.	10	Color of Wire	B/W	Signal Name	-
--------------	----	---------------	-----	-------------	---

Connector No.	M8
Connector Name	WIRE TO WIRE
Connector Color	WHITE

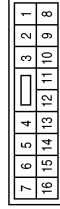

Terminal No.	14	Color of Wire	B	Signal Name	-
--------------	----	---------------	---	-------------	---

Connector No.	M14
Connector Name	WIRE TO WIRE
Connector Color	WHITE

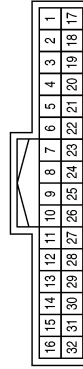

Terminal No.	23	Color of Wire	GR/W	Signal Name	-
--------------	----	---------------	------	-------------	---

Connector No.	M18
Connector Name	BCM (BODY CONTROL MODULE)
Connector Color	WHITE

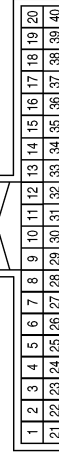

Terminal No.	38	Color of Wire	W/L	Signal Name	IGN SW
Terminal No.	39	Color of Wire	L	Signal Name	CAN-H
Terminal No.	40	Color of Wire	P	Signal Name	CAN-L

Connector No.	M19
Connector Name	BCM (BODY CONTROL MODULE)
Connector Color	WHITE

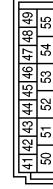

Terminal No.	41	Color of Wire	Y/B	Signal Name	REAR DEFOGGER SW
--------------	----	---------------	-----	-------------	------------------

REAR WINDOW DEFOGGER

< WIRING DIAGRAM >

Connector No.	M20
Connector Name	BCM (BODY CONTROL MODULE)
Connector Color	BLACK



56	57	58	59	60	61	62	63	64
65	66	67	68	69	70			

Terminal No.	Color of Wire	Signal Name
67	B	GND (POWER)
70	W/B	BAT (F/L)

Connector No.	M31
Connector Name	WIRE TO WIRE
Connector Color	WHITE

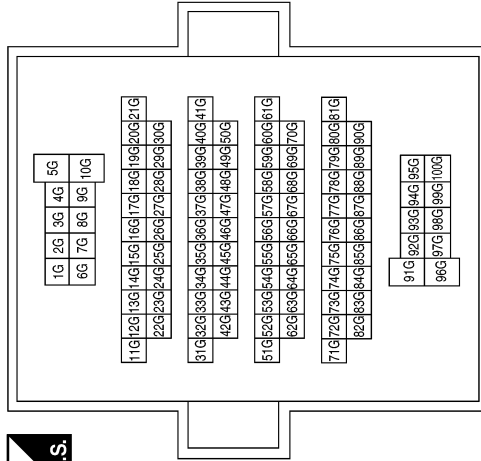

Terminal No.	Color of Wire	Signal Name
31G	L	-
32G	P	-
96G	W/B	-
99G	W/L	-
100G	GR/W	-

Connector No.	M40
Connector Name	WIRE TO WIRE
Connector Color	WHITE

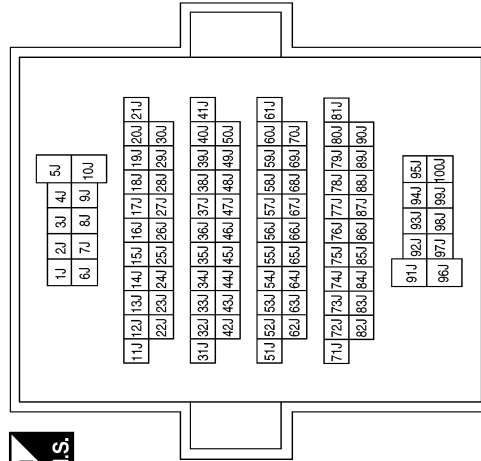

Terminal No.	Color of Wire	Signal Name
24J	W/R	-
99J	W/L	-

Connector No.	M49
Connector Name	FRONT AIR CONTROL (WITH AUTO A/C)
Connector Color	BLACK



13	12	11	10	9	8	7	6	5	4	3	2	1
20	25	24	23	22	21	20	19	18	17	16	15	14

Terminal No.	Color of Wire	Signal Name
15	Y/G	IGN
16	Y/B	REAR DEF REQ

ABLIA6491GB

REAR WINDOW DEFOGGER

< WIRING DIAGRAM >

Connector No.	M75
Connector Name	WIRE TO WIRE
Connector Color	WHITE

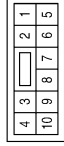

Terminal No.	Color of Wire	Signal Name
3	B	-

Connector No.	M74
Connector Name	WIRE TO WIRE
Connector Color	BROWN

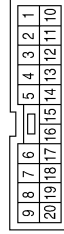

Terminal No.	Color of Wire	Signal Name
3	GRW	-

Connector No.	M50
Connector Name	FRONT AIR CONTROL (WITH AUTO A/C)
Connector Color	WHITE

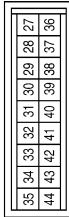

Terminal No.	Color of Wire	Signal Name
35	B	GND
36	P	CAN-L
37	L	CAN-H

Connector No.	M178
Connector Name	JOINT CONNECTOR-M08
Connector Color	WHITE

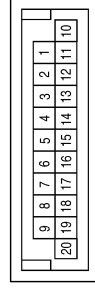

Terminal No.	Color of Wire	Signal Name
10	L	-
11	L	-
14	L	-
16	P	-
17	P	-
20	P	-

Connector No.	M177
Connector Name	FRONT AIR CONTROL (WITH MANUAL 3 CONTROL DIAL SYSTEM)
Connector Color	GREEN

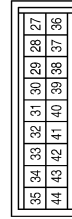

Terminal No.	Color of Wire	Signal Name
34	L	CAN-H
35	P	CAN-L

Connector No.	M176
Connector Name	FRONT AIR CONTROL (WITH MANUAL 3 CONTROL DIAL SYSTEM)
Connector Color	BLACK

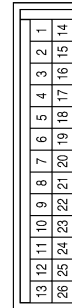

Terminal No.	Color of Wire	Signal Name
1	B	GND
11	Y/B	HB REQUEST
14	Y/G	V IGN

ABLIA4182GB

A
B
C
D
E
F
G
H
I
J
K
DEF
M
N
O
P

REAR WINDOW DEFOGGER

< WIRING DIAGRAM >

Connector No.	M181
Connector Name	FRONT AIR CONTROL (WITH MANUAL 2 CONTROL DIAL SYSTEM)
Connector Color	WHITE



35	34	33	32	31	30	29	28	27
44	43	42	41	40	39	38	37	36

Terminal No.	Color of Wire	Signal Name
35	B	GND
36	P	CAN-L
37	L	CAN-H

Connector No.	M180
Connector Name	FRONT AIR CONTROL (WITH MANUAL 2 CONTROL DIAL SYSTEM)
Connector Color	BLACK



13	12	11	10	9	8	7	6	5	4	3	2	1
26	25	24	23	22	21	20	19	18	17	16	15	14

Terminal No.	Color of Wire	Signal Name
15	Y/G	V IGN
16	Y/B	REAR DEF REQUEST

Connector No.	M179
Connector Name	JOINT CONNECTOR-M07
Connector Color	WHITE



9	8	7	6	5	4	3	2	1		
20	19	18	17	16	15	14	13	12	11	10

Terminal No.	Color of Wire	Signal Name
4	GR/W	-
5	GR/W	-
6	GR/W	-
10	L	-
11	L	-
16	P	-
17	P	-

Connector No.	E10
Connector Name	WIRE TO WIRE
Connector Color	WHITE



1	2	3	4		
5	6	7	8	9	10

Terminal No.	10	Color of Wire	B/W	Signal Name	-
--------------	----	---------------	-----	-------------	---

Connector No.	M187
Connector Name	REAR WINDOW DEFOGGER CUT-OFF RELAY
Connector Color	BLUE



Terminal No.	Color of Wire	Signal Name
1	W/R	-
2	B/W	-
3	B/W	-
5	W/L	-

Connector No.	M182
Connector Name	JOINT CONNECTOR-M09
Connector Color	GREEN



9	8	7	6	5	4	3	2	1		
20	19	18	17	16	15	14	13	12	11	10

Terminal No.	Color of Wire	Signal Name
10	Y/G	-
11	Y/G	-
14	L	-
15	L	-
18	P	-
19	P	-

ABLIA6492GB

REAR WINDOW DEFOGGER

< WIRING DIAGRAM >

Connector No.	E124
Connector Name	IPDM E/R (INTELLIGENT POWER DISTRIBUTION MODULE ENGINE ROOM)
Connector Color	BLACK



Terminal No.	Color of Wire	Signal Name
59	B	GND (POWER)
60	B/W	RR DEF

Connector No.	E122
Connector Name	IPDM E/R (INTELLIGENT POWER DISTRIBUTION MODULE ENGINE ROOM)
Connector Color	WHITE



Terminal No.	Color of Wire	Signal Name
38	B	GND (SIGNAL)
39	L	CAN-H
40	P	CAN-L

Connector No.	E120
Connector Name	IPDM E/R (INTELLIGENT POWER DISTRIBUTION MODULE ENGINE ROOM)
Connector Color	WHITE



Terminal No.	Color of Wire	Signal Name
23	GR/W	HEATED MIRROR

Connector No.	E152
Connector Name	WIRE TO WIRE
Connector Color	WHITE



Terminal No.	Color of Wire	Signal Name
31G	L	-
32G	P	-
96G	W/B	-
99G	L/W	-
100G	GR/W	-

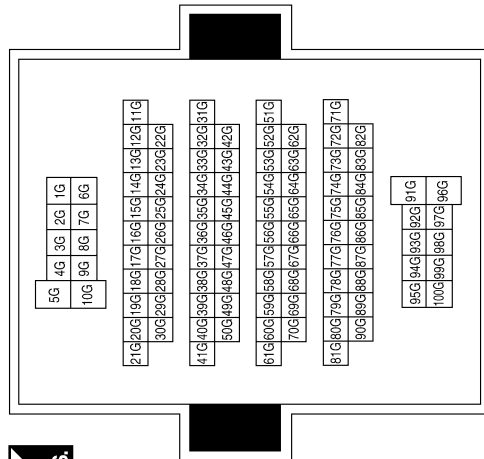

ABLIA4184GB

A
B
C
D
E
F
G
H
I
J
K
DEF
M
N
O
P

REAR WINDOW DEFOGGER

< WIRING DIAGRAM >

Connector No.	B80
Connector Name	REAR POWER DROP GLASS MOTOR
Connector Color	GRAY



Terminal No.	Color of Wire	Signal Name
2	W/R	-
3	B	-

Connector No.	B78
Connector Name	REAR WINDOW DEFOGGER
Connector Color	BLACK



Terminal No.	Color of Wire	Signal Name
1	W/L	-

Connector No.	B69
Connector Name	WIRE TO WIRE
Connector Color	WHITE

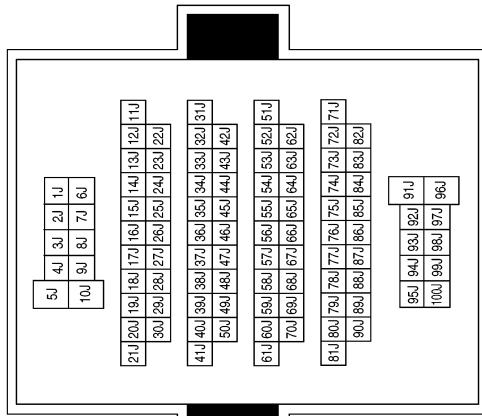

Terminal No.	Color of Wire	Signal Name
24J	W/R	-
99J	W/L	-

Connector No.	D4
Connector Name	DOOR MIRROR L.H. (WITH AUTOMATIC DRIVE POSITIONER)
Connector Color	WHITE



Terminal No.	Color of Wire	Signal Name
10	GR/W	-
11	B	-

Connector No.	D2
Connector Name	WIRE TO WIRE
Connector Color	WHITE



Terminal No.	Color of Wire	Signal Name
14	B	-

Connector No.	B81
Connector Name	REAR WINDOW DEFOGGER
Connector Color	BLACK



Terminal No.	Color of Wire	Signal Name
2	B	-

AALIA3478GB

REAR WINDOW DEFOGGER

< WIRING DIAGRAM >

Connector No.	D101
Connector Name	WIRE TO WIRE
Connector Color	WHITE

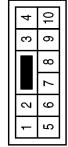

Terminal No.	3	Color of Wire	B	Signal Name	-
--------------	---	---------------	---	-------------	---

Connector No.	D18
Connector Name	WIRE TO WIRE
Connector Color	WHITE

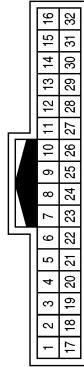

Terminal No.	23	Color of Wire	GRW	Signal Name	-
--------------	----	---------------	-----	-------------	---

Connector No.	D6
Connector Name	DOOR MIRROR LH (WITHOUT AUTOMATIC DRIVE POSITIONER)
Connector Color	WHITE



Terminal No.	4	Color of Wire	GRW	Signal Name	-
	6		B		-

Connector No.	D107
Connector Name	DOOR MIRROR RH (WITH AUTOMATIC DRIVE POSITIONER)
Connector Color	WHITE



Terminal No.	10	Color of Wire	GRW	Signal Name	-
	11		B		-

Connector No.	D106
Connector Name	DOOR MIRROR RH (WITHOUT AUTOMATIC DRIVE POSITIONER)
Connector Color	WHITE



Terminal No.	4	Color of Wire	GRW	Signal Name	-
	6		B		-

Connector No.	D102
Connector Name	WIRE TO WIRE
Connector Color	BROWN



Terminal No.	3	Color of Wire	GRW	Signal Name	-
--------------	---	---------------	-----	-------------	---

AALIA3479GB

A
B
C
D
E
F
G
H
I
J
K
DEF
M
N
O
P

REAR WINDOW DEFOGGER SYSTEM SYMPTOMS

< SYMPTOM DIAGNOSIS >

SYMPTOM DIAGNOSIS

REAR WINDOW DEFOGGER SYSTEM SYMPTOMS

Symptom Table

INFOID:000000011560035

Symptom	Diagnoses / Service procedure	Refer to page
Rear window defogger and door mirror defoggers do not operate. (with heated mirrors)	1. BCM power supply and ground circuit check	BCS-31
	2. IPDM E/R auto active test check	PCS-13
	3. Rear window defogger switch circuit check	DEF-41
	4. Rear window defogger circuit check	DEF-41
	5. Replace IPDM E/R	PCS-28
Rear window defogger does not operate. (without heated mirrors)	1. BCM power supply and ground circuit check	BCS-31
	2. IPDM E/R auto active test check	PCS-13
	3. Rear window defogger switch circuit check	DEF-9
	4. Rear window defogger circuit check	DEF-12
	5. Filament check	DEF-48
	6. Replace IPDM E/R	PCS-28
Rear window defogger does not operate but both of door mirror defoggers operate. (with heated mirrors)	1. Rear window defogger circuit check	DEF-42
	2. Filament check	DEF-48
	3. Replace IPDM E/R	PCS-28
Both door mirror defoggers do not operate but rear window defogger operates. (with heated mirrors)	1. Door mirror defogger power supply circuit check	DEF-43
	2. Replace IPDM E/R	PCS-28
Door mirror LH defogger does not operate. (with heated mirrors)	1. Door mirror LH defogger circuit check	DEF-44
Door mirror RH defogger does not operate. (with heated mirrors)	1. Door mirror RH defogger circuit check	DEF-45
Rear window defogger switch does not light, and rear window defogger is not shown on the display, but rear window defogger operates.	1. Replace front air control	VTL-8

REAR WINDOW DEFOGGER AND DOOR MIRROR DEFOGGER DO NOT OPERATE.

< SYMPTOM DIAGNOSIS >

REAR WINDOW DEFOGGER AND DOOR MIRROR DEFOGGER DO NOT OPERATE.

Diagnosis Procedure

INFOID:000000011560036

1. CHECK REAR WINDOW DEFOGGER SWITCH

Check rear window defogger switch.

If equipped 2 control dial system or auto A/C, refer to [DEF-9, "Component Function Check \(2 Control Dial System or Auto A/C\)"](#).

If equipped 3 control dial system or without auto A/C, refer to [DEF-9, "Component Function Check \(3 Control Dial System Without Auto A/C\)"](#).

Is the inspection result normal?

YES >> GO TO 2

NO >> Repair or replace the malfunctioning parts.

2. CHECK REAR WINDOW DEFOGGER RELAY

Check rear window defogger relay.

Refer to [DEF-11, "Component Function Check"](#).

Is the inspection result normal?

YES >> GO TO 3

NO >> Repair or replace the malfunctioning parts.

3. CHECK REAR WINDOW DEFOGGER SYSTEM

Check rear window defogger system.

Refer to [DEF-12, "Component Function Check"](#).

Is the inspection result normal?

YES >> GO TO 4

NO >> Repair or replace the malfunctioning parts.

4. CHECK INTERMITTENT INCIDENT

Check intermittent incident.

Refer to [GI-44, "Intermittent Incident"](#).

Is the inspection result normal?

YES >> Check the following.

- Battery power supply circuit
- IPDM E/R

NO >> Repair or replace the malfunctioning parts.

A
B
C
D
E
F
G
H
I
J
K
DEF
M
N
O
P

REAR WINDOW DEFOGGER DOES NOT OPERATE BUT BOTH OF DOOR MIRROR DEFOGGER OPERATE.

< SYMPTOM DIAGNOSIS >

REAR WINDOW DEFOGGER DOES NOT OPERATE BUT BOTH OF DOOR MIRROR DEFOGGER OPERATE.

Diagnosis Procedure

INFOID:000000011560037

1. CHECK REAR WINDOW DEFOGGER POWER SUPPLY AND GROUND CIRCUIT

Check rear window defogger power supply and ground circuit.

Refer to [DEF-12, "Diagnosis Procedure"](#).

Is the inspection result normal?

YES >> Refer to [GI-44, "Intermittent Incident"](#).

NO >> Repair or replace the malfunctioning parts.

BOTH DOORS MIRROR DEFOGGER DON'T OPERATE BUT REAR WINDOW DEFOGGER OPERATES

< SYMPTOM DIAGNOSIS >

BOTH DOORS MIRROR DEFOGGER DON'T OPERATE BUT REAR WINDOW DEFOGGER OPERATES

Diagnosis Procedure

INFOID:000000011560038

1. CHECK BOTH DOOR MIRROR DEFOGGER

1. Check door mirror LH. Refer to [DEF-15, "Component Function Check"](#).
2. Check door mirror RH. Refer to [DEF-18, "Component Function Check"](#).

Is the inspection result normal?

- YES >> Check intermittent incident. Refer to [GI-44, "Intermittent Incident"](#).
NO >> Repair or replace the malfunctioning parts.

A
B
C
D
E
F
G
H
I
J
K
DEF
M
N
O
P

DRIVER SIDE DOOR MIRROR DEFOGGER DOES NOT OPERATE.

< SYMPTOM DIAGNOSIS >

DRIVER SIDE DOOR MIRROR DEFOGGER DOES NOT OPERATE.

Diagnosis Procedure

INFOID:000000011560039

1. CHECK DOOR MIRROR DEFOGGER LH

Check door mirror defogger LH.

Refer to [DEF-15, "Diagnosis Procedure"](#).

Is the inspection result normal?

YES >> Refer to [GI-44, "Intermittent Incident"](#).

NO >> Repair or replace the malfunctioning parts.

PASSENGER SIDE DOOR MIRROR DEFOGGER DOES NOT OPERATE.

< SYMPTOM DIAGNOSIS >

PASSENGER SIDE DOOR MIRROR DEFOGGER DOES NOT OPERATE.

Diagnosis Procedure

INFOID:000000011560040

1. CHECK DOOR MIRROR DEFOGGER RH

Check door mirror defogger RH.

Refer to [DEF-18, "Diagnosis Procedure"](#).

Is the inspection result normal?

YES >> Refer to [GI-44, "Intermittent Incident"](#).

NO >> Repair or replace the malfunctioning parts.

A
B
C
D
E
F
G
H
I
J
K
DEF
M
N
O
P

REAR WINDOW DEFOGGER SWITCH DOES NOT LIGHT, BUT REAR WINDOW DEFOGGER OPERATES

< SYMPTOM DIAGNOSIS >

REAR WINDOW DEFOGGER SWITCH DOES NOT LIGHT, BUT REAR WINDOW DEFOGGER OPERATES

Diagnosis Procedure

INFOID:000000011560041

1. CHECK FRONT AIR CONTROL (REAR WINDOW DEFOGGER SWITCH)

Check that the front air control (rear window defogger switch) is operating normally.

Is the inspection result normal?

YES >> Refer to [GI-44, "Intermittent Incident"](#).

NO >> Refer to [DEF-9, "Diagnosis Procedure \(2 Control Dial System or Auto A/C\)"](#) or [DEF-10, "Diagnosis Procedure \(3 Control Dial System Without Auto A/C\)"](#).

PRECAUTIONS

< PRECAUTION >

PRECAUTION

PRECAUTIONS

Precaution for Supplemental Restraint System (SRS) "AIR BAG" and "SEAT BELT PRE-TENSIONER"

INFOID:000000011560042

The Supplemental Restraint System such as "AIR BAG" and "SEAT BELT PRE-TENSIONER", used along with a front seat belt, helps to reduce the risk or severity of injury to the driver and front passenger for certain types of collision. This system includes seat belt switch inputs and dual stage front air bag modules. The SRS system uses the seat belt switches to determine the front air bag deployment, and may only deploy one front air bag, depending on the severity of a collision and whether the front occupants are belted or unbelted. Information necessary to service the system safely is included in the SR and SB section of this Service Manual.

WARNING:

- To avoid rendering the SRS inoperative, which could increase the risk of personal injury or death in the event of a collision which would result in air bag inflation, all maintenance must be performed by an authorized NISSAN/INFINITI dealer.
- Improper maintenance, including incorrect removal and installation of the SRS, can lead to personal injury caused by unintentional activation of the system. For removal of Spiral Cable and Air Bag Module, see the SR section.
- Do not use electrical test equipment on any circuit related to the SRS unless instructed to in this Service Manual. SRS wiring harnesses can be identified by yellow and/or orange harnesses or harness connectors.

PRECAUTIONS WHEN USING POWER TOOLS (AIR OR ELECTRIC) AND HAMMERS

WARNING:

- When working near the Airbag Diagnosis Sensor Unit or other Airbag System sensors with the Ignition ON or engine running, DO NOT use air or electric power tools or strike near the sensor(s) with a hammer. Heavy vibration could activate the sensor(s) and deploy the air bag(s), possibly causing serious injury.
- When using air or electric power tools or hammers, always switch the Ignition OFF, disconnect the battery and wait at least three minutes before performing any service.

Handling for Adhesive and Primer

INFOID:000000011560043

- Do not use an adhesive which is past its usable date. Shelf life of this product is limited to six months after the date of manufacture. Carefully adhere to the expiration or manufacture date printed on the box.
- Keep primers and adhesive in a cool, dry place. Ideally, they should be stored in a refrigerator.
- Open the seal of the primer and adhesive just before application. Discard the remainder.
- Before application, be sure to shake the primer container to stir the contents. If any floating material is found, do not use it.
- If any primer or adhesive contacts the skin, wipe it off with gasoline or equivalent and wash the skin with soap.
- When using primer and adhesive, always observe the precautions in the instruction manual.

A
B
C
D
E
F
G
H
I
J
K
DEF
M
N
O
P

REAR WINDOW DEFOGGER

< REMOVAL AND INSTALLATION >

REMOVAL AND INSTALLATION

REAR WINDOW DEFOGGER

Filament Check

INFOID:000000011560044

1. When measuring voltage, wrap tin foil around the top of the negative probe. Then press the foil against the wire with your finger.

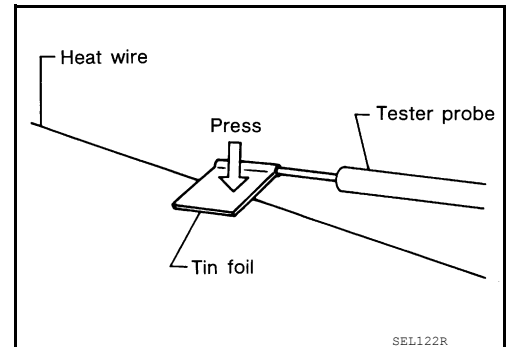

2. Attach probe circuit tester (in Volt range) to middle portion of each filament.

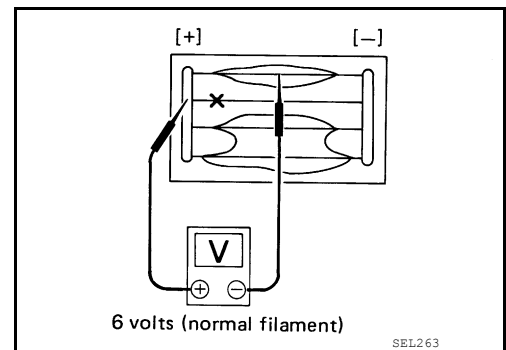

3. If a filament is burned out, circuit tester registers 0 or battery voltage.
4. To locate burned out point, move probe to left and right along filament. Test needle will swing abruptly when probe passes the point.

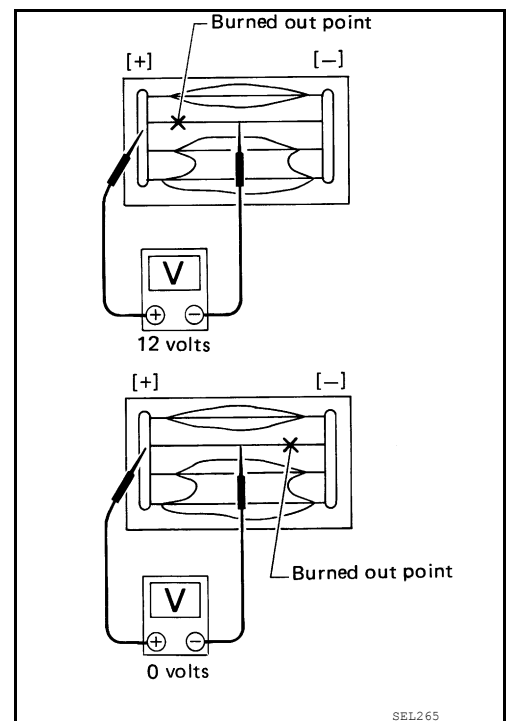

Filament Repair

INFOID:000000011560045

REPAIR EQUIPMENT

- Conductive silver composition (DuPont No. 4817 or equivalent)
- Ruler 30 cm (11.8 in) long

REAR WINDOW DEFOGGER

< REMOVAL AND INSTALLATION >

- Drawing pen
- Heat gun
- Alcohol
- Cloth

REPAIRING PROCEDURE

1. Wipe broken heat wire and its surrounding area clean with a cloth dampened in alcohol.
2. Apply a small amount of conductive silver composition to tip of drawing pen.

NOTE:

Shake silver composition container before use.

3. Place ruler on glass along broken line. Deposit conductive silver composition on break with drawing pen. Slightly overlap existing heat wire on both sides [preferably 5 mm (0.20 in)] of the break.

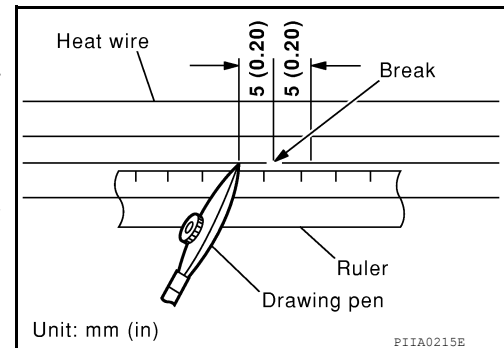

4. After repair has been completed, check repaired wire for continuity. This check should be conducted 10 minutes after silver composition is deposited.

CAUTION:

Do not touch repaired area while test is being conducted.

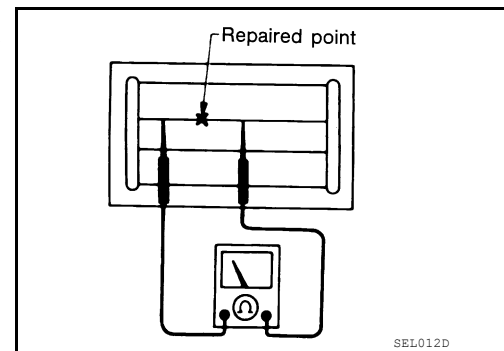

5. Apply a constant stream of hot air directly to the repaired area for approximately 20 minutes with a heat gun. A minimum distance of 3 cm (1.2 in) should be kept between repaired area and hot air outlet.

NOTE:

If a heat gun is not available, let the repaired area dry for 24 hours.

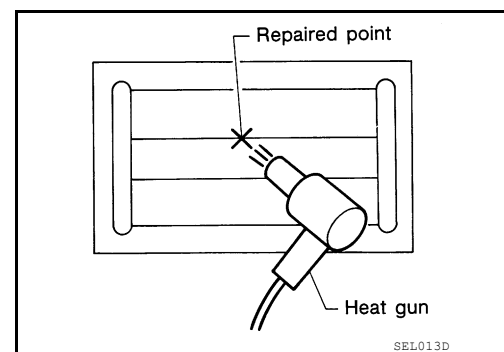

A
B
C
D
E
F
G
H
I
J
K
DEF
M
N
O
P