

A
B
C

SECTION **WW**

WIPER & WASHER

CONTENTS

BASIC INSPECTION	3	Diagnosis Procedure	19	F
DIAGNOSIS AND REPAIR WORKFLOW	3	FRONT WIPER MOTOR GROUND CIRCUIT ...	21	
Work Flow	3	Diagnosis Procedure	21	G
SYSTEM DESCRIPTION	4	WASHER SWITCH	22	
FRONT WIPER AND WASHER SYSTEM	4	Description	22	H
System Diagram	4	Component Inspection	22	
System Description	4	WASHER MOTOR CIRCUIT	23	
Component Parts Location	7	Diagnosis Procedure	23	I
Component Description	7	ECU DIAGNOSIS INFORMATION	25	
DIAGNOSIS SYSTEM (BCM)	8	BCM (BODY CONTROL MODULE)	25	J
COMMON ITEM	8	Reference Value	25	
COMMON ITEM : CONSULT Function (BCM -		Terminal Layout	28	
COMMON ITEM)	8	Physical Values	28	K
WIPER	8	Fail Safe	33	
WIPER : CONSULT Function (BCM - WIPER)	9	DTC Inspection Priority Chart	33	
DIAGNOSIS SYSTEM (IPDM E/R)	10	DTC Index	34	WW
Diagnosis Description	10	IPDM E/R (INTELLIGENT POWER DISTRI-	36	
CONSULT Function (IPDM E/R)	12	BUTION MODULE ENGINE ROOM)	36	M
DTC/CIRCUIT DIAGNOSIS	14	Reference Value	36	
WIPER AND WASHER FUSE	14	Terminal Layout	37	
Description	14	Physical Values	37	N
Diagnosis Procedure	14	Fail Safe	40	
FRONT WIPER MOTOR LO CIRCUIT	15	DTC Index	41	O
Component Function Check	15	WIRING DIAGRAM	42	
Diagnosis Procedure	15	FRONT WIPER AND WASHER SYSTEM	42	P
FRONT WIPER MOTOR HI CIRCUIT	17	Wiring Diagram	42	
Component Function Check	17	SYMPTOM DIAGNOSIS	47	
Diagnosis Procedure	17	WIPER AND WASHER SYSTEM SYMPTOMS	47	
FRONT WIPER AUTO STOP SIGNAL CIR-	19	Symptom Table	47	
CUIT	19	NORMAL OPERATING CONDITION	49	
Component Function Check	19	Description	49	

FRONT WIPER DOES NOT OPERATE	50	FRONT WASHER NOZZLE AND TUBE	56
Description	50	Washer Tube Layout	56
Diagnosis Procedure	50	Washer Nozzle Adjustment	56
PRECAUTION	52	FRONT WIPER AND WASHER SWITCH	57
PRECAUTION	52	Wiper and Washer Switch	57
Precaution for Supplemental Restraint System (SRS) "AIR BAG" and "SEAT BELT PRE-TEN- SIONER"	52	WASHER PUMP	58
REMOVAL AND INSTALLATION	53	Washer Motor	58
FRONT WIPER ARM	53	WASHER LEVEL SWITCH	59
Front Wiper Arms	53	Removal and Installation	59
FRONT WIPER DRIVE ASSEMBLY	54	SERVICE DATA AND SPECIFICATIONS (SDS)	60
Wiper Motor and Linkage	54	SERVICE DATA AND SPECIFICATIONS (SDS)	60
WASHER TANK	55	Specifications	60
Washer Fluid Reservoir	55		

DIAGNOSIS AND REPAIR WORKFLOW

< BASIC INSPECTION >

BASIC INSPECTION

DIAGNOSIS AND REPAIR WORKFLOW

Work Flow

INFOID:0000000011559956

DETAILED FLOW

1. LISTEN TO CUSTOMER COMPLAINT

Listen to customer complaint. Get detailed information about the conditions and environment when the symptom occurs.

>> GO TO 2.

2. VERIFY THE SYMPTOM WITH OPERATIONAL CHECK

Verify the symptom with operational check. Refer to [WW-50, "Diagnosis Procedure"](#).

>> GO TO 3.

3. GO TO APPROPRIATE TROUBLE DIAGNOSIS

Go to appropriate trouble diagnosis. Refer to [WW-47, "Symptom Table"](#).

>> GO TO 4.

4. REPAIR OR REPLACE

Repair or replace the specific parts.

>> GO TO 5.

5. FINAL CHECK

Final check.

Is inspection result normal?

YES >> Inspection End.

NO >> Refer to [GI-44, "Intermittent Incident"](#).

A
B
C
D
E
F
G
H
I
J
K
M
N
O
P

WW

FRONT WIPER AND WASHER SYSTEM

< SYSTEM DESCRIPTION >

SYSTEM DESCRIPTION

FRONT WIPER AND WASHER SYSTEM

System Diagram

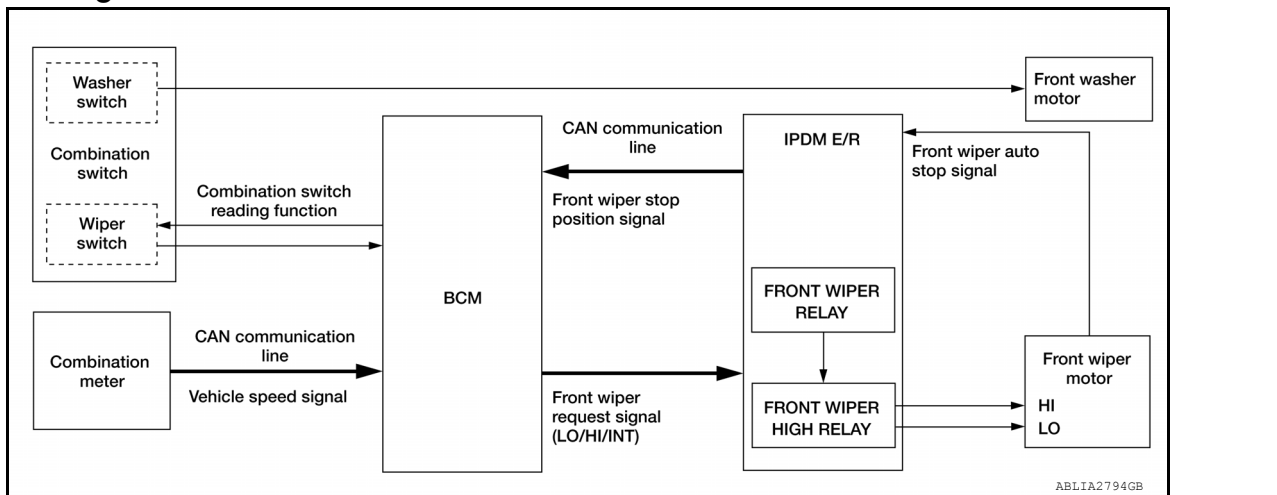

System Description

INFOID:000000011559958

OUTLINE

The front wiper is controlled by each function of BCM and IPDM E/R.

Control by BCM

- Combination switch reading function
- Front wiper control function

Control by IPDM E/R

- Front wiper control function
- Relay control function

FRONT WIPER BASIC OPERATION

- BCM detects the combination switch condition by the combination switch reading function.
- BCM transmits the front wiper request signal to IPDM E/R with CAN communication depending on each operating condition of the front wiper.
- IPDM E/R turns ON/OFF the integrated front wiper relay and the front wiper high relay according to the front wiper request signal. IPDM E/R provides the power supply to operate the front wiper HI/LO operation.

FRONT WIPER LO OPERATION

- BCM transmits the front wiper request signal (LO) to IPDM E/R with CAN communication according to the front wiper LO operating condition.

Front wiper LO operating condition

- Ignition switch ON
- Front wiper switch LO or front wiper switch MIST (while pressing)
- IPDM E/R turns ON the integrated front wiper relay according to the front wiper request signal (LO).

FRONT WIPER HI OPERATION

- BCM transmits the front wiper request signal (HI) to IPDM E/R with CAN communication according to the front wiper HI operating condition.

Front wiper HI operating condition

- Ignition switch ON
- Front wiper switch HI
- IPDM E/R turns ON the integrated front wiper relay and the front wiper high relay according to the front wiper request signal (HI).

FRONT WIPER INT OPERATION (LINKED WITH VEHICLE SPEED)

FRONT WIPER AND WASHER SYSTEM

< SYSTEM DESCRIPTION >

- BCM transmits the front wiper request signal (INT) to IPDM E/R with CAN communication according to the front wiper INT operation condition and the intermittent operation delay interval judged value.

Front wiper INT operating condition

- Ignition switch ON
- Front wiper switch INT

Intermittent operation delay interval judgment

- BCM calculates the intermittent operation delay interval from the vehicle speed signal received from the wiper dial position and the combination meter with CAN communication.

Wiper intermittent dial position	Intermittent operation interval	Intermittent operation delay Interval (s)			
		Vehicle speed			
		Vehicle stopped or less than 5 km/h (3.1 MPH)	5 km/h (3.1 MPH) or more or less than 35 km/h (21.7 MPH)	35 km/h (21.7 MPH) or more or less than 65 km/h (40.4 MPH)	65 km/h (40.4 MPH) or more
1	Short ↑	0.8	0.6	0.4	0.24
2		4	3	2	1.2
3		10	7.5	5	3
4		16	12	8	4.8
5		24	18	12	7.2
6	Long ↓	32	24	16	9.6
7		42	31.5	21	12.6

- IPDM E/R turns the integrated front wiper relay ON so that the front wiper is operated only once according to the front wiper request signal (INT).
- BCM detects stop position/except stop position of the front wiper motor according to the front wiper stop position signal received from IPDM E/R with CAN communication.
- BCM transmits the front wiper request signal (INT) again after the intermittent operation delay interval after the front wiper motor is stopped.

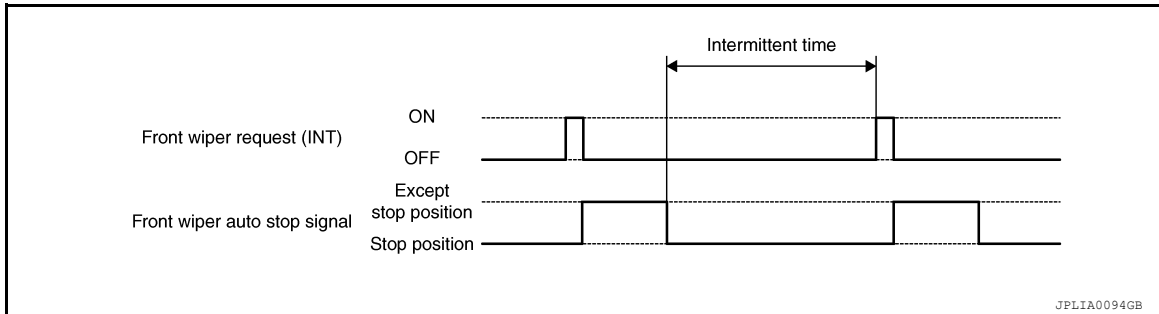

FRONT WIPER AUTO STOP OPERATION

- BCM stops transmitting the front wiper request signal when the front wiper switch is turned OFF.
- IPDM E/R detects the front wiper auto stop signal from the front wiper motor and detects the front wiper motor position (stop position/except stop position).

FRONT WIPER AND WASHER SYSTEM

< SYSTEM DESCRIPTION >

- When the front wiper request signal is stopped, IPDM E/R turns ON the front wiper relay until the front wiper motor returns to the stop position.

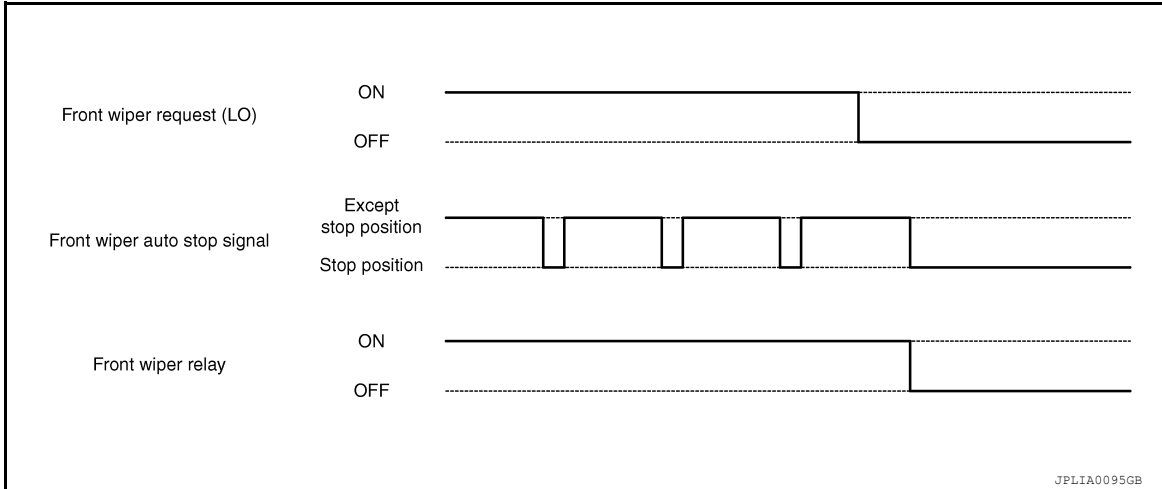

NOTE:

- BCM stops the transmitting of the front wiper request signal when the ignition switch is OFF.
- IPDM E/R turns the front wiper relay OFF when the ignition switch is OFF.

FRONT WIPER OPERATION LINKED WITH WASHER

- BCM transmits the front wiper request signal (LO) to IPDM E/R with CAN communication according to the washer linked operating condition of the front wiper.
- BCM transmits the front wiper request signal (LO) so that the front wiper operates approximately 3 times when the front washer switch OFF is detected.

Washer linked operating condition of front wiper

- Ignition switch ON
- Front washer switch ON (0.4 second or more)
- IPDM E/R turns ON the integrated front wiper relay according to the front wiper request signal (LO).
- The front washer motor is grounded through the combination switch with the front washer switch ON.

FRONT WIPER DROP WIPE OPERATION

- BCM controls the front wiper to operate once according to the conditions of front wiper drop wipe operation.

Front wiper drop wipe operating condition

- Ignition switch ON
- Front wiper switch OFF
- Front washer switch OFF
- BCM transmits the front wiper request signal (LO) to IPDM E/R with CAN communication so that the front wiper operates once three seconds after front wiper operation linked with washer.
- IPDM E/R turns ON the integrated front wiper relay according to the front wiper request signal (LO).

FRONT WIPER FAIL-SAFE OPERATION

- IPDM E/R performs the fail-safe function when the front wiper auto stop circuit is malfunctioning. Refer to [PCS-21, "Fail Safe"](#).

FRONT WIPER AND WASHER SYSTEM

< SYSTEM DESCRIPTION >

Component Parts Location

INFOID:000000011559959

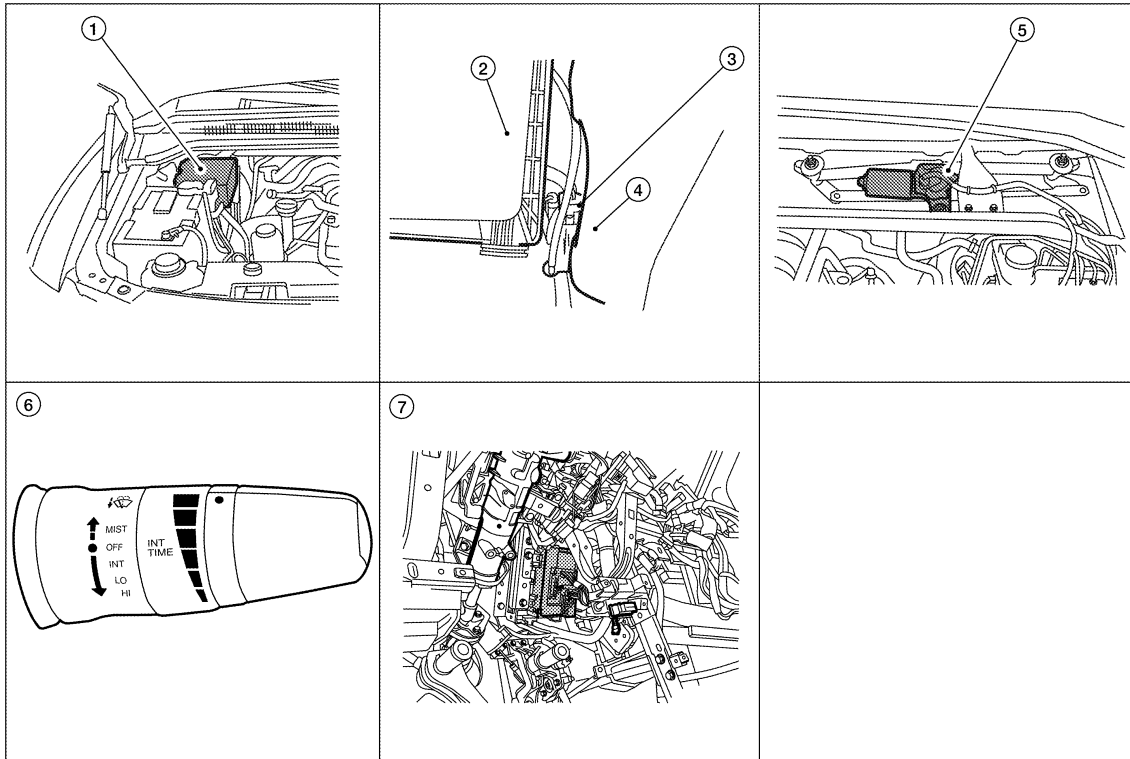

- | | | |
|--|--|---|
| 1. IPDM E/R E121, E122, E124 | 2. Air cleaner case | 3. Front washer motor E105 |
| 4. Washer fluid reservoir | 5. Front wiper motor E23
(view with cowl top removed) | 6. Combination switch (wiper and washer switch) M28 |
| 7. BCM M18, M20 (view with instrument panel removed) | | |

ALLIA08482Z

Component Description

INFOID:000000011559960

Part	Description
BCM	<ul style="list-style-type: none"> Judges each switch status by the combination switch reading function. Requests (with CAN communication) the front wiper relay and the front wiper high relay ON to IPDM E/R.
IPDM E/R	<ul style="list-style-type: none"> Controls the integrated relay according to the request (with CAN communication) from BCM. Performs the auto stop control of the front wiper.
Combination switch (wiper and washer switch)	Refer to WW-4, "System Description" .
Combination meter	Transmits the vehicle speed signal to BCM with CAN communication.
Front wiper motor	<ul style="list-style-type: none"> Drives windshield wipers in HI or LO mode. Sends wiper stop signal to IPDM E/R.
Front washer motor	Pumps windshield washer fluid to windshield in wash mode.

A
B
C
D
E
F
G
H
I
J
K

WW

M
N
O
P

DIAGNOSIS SYSTEM (BCM)

< SYSTEM DESCRIPTION >

DIAGNOSIS SYSTEM (BCM)

COMMON ITEM

COMMON ITEM : CONSULT Function (BCM - COMMON ITEM)

INFOID:000000011863125

APPLICATION ITEM

CONSULT performs the following functions via CAN communication with BCM:

Direct Diagnostic Mode	Description
Ecu Identification	The BCM part number is displayed.
Self Diagnostic Result	The BCM self diagnostic results are displayed.
Data Monitor	The BCM input/output data is displayed in real time.
Active Test	The BCM activates outputs to test components.
Work support	The settings for BCM functions can be changed.
Configuration	<ul style="list-style-type: none"> • The vehicle specification can be read and saved. • The vehicle specification can be written when replacing BCM.
CAN Diag Support Mntr	The result of transmit/receive diagnosis of CAN communication is displayed.

SYSTEM APPLICATION

BCM can perform the following functions:

System	Sub System	Direct Diagnostic Mode						
		Ecu Identification	Self Diagnostic Result	Data Monitor	Active Test	Work support	Configuration	CAN Diag Support Mntr
Door lock	DOOR LOCK			x	x	x		
Rear window defogger	REAR DEFOGGER			x	x			
Warning chime	BUZZER			x	x			
Interior room lamp timer	INT LAMP			x	x	x		
Remote keyless entry system	MULTI REMOTE ENT			x	x	x		
Exterior lamp	HEADLAMP			x	x	x		
Wiper and washer	WIPER			x	x	x		
Turn signal and hazard warning lamps	FLASHER			x	x			
Air conditioner	AIR CONDITIONER			x				
Combination switch	COMB SW			x				
BCM	BCM	x	x			x	x	x
Immobilizer	IMMU		x	x	x			
Interior room lamp battery saver	BATTERY SAVER			x	x	x		
Vehicle security system	THEFT ALM			x	x	x		
RAP system	RETAINED PWR			x	x	x		
Signal buffer system	SIGNAL BUFFER			x	x			
TPMS	AIR PRESSURE MONITOR		x	x	x	x		
Panic alarm system	PANIC ALARM				x			

WIPER

DIAGNOSIS SYSTEM (BCM)

< SYSTEM DESCRIPTION >

WIPER : CONSULT Function (BCM - WIPER)

INFOID:000000011863126

DATA MONITOR

Monitor Item [Unit]	Description
IGN ON SW [On/Off]	Indicates condition of ignition switch ON position.
IGN SW CAN [On/Off]	Indicates ignition switch ON signal received from IPDM E/R on CAN communication line.
FR WIPER HI [On/Off]	Indicates condition of front wiper operation of combination switch.
FR WIPER LOW [On/Off]	
FR WIPER INT [On/Off]	
FR WASHER SW [On/Off]	
INT VOLUME [1 - 7]	
FR WIPER STOP [On/Off]	Indicates front wiper motor auto stop signal received from IPDM E/R on CAN communication line.
VEHICLE SPEED [km/h/mph]	Indicates vehicle speed signal received from combination meter on CAN communication line.

ACTIVE TEST

Test Item	Description
FR WIPER	This test is able to check front wiper operation [Off/INT/Lo/Hi].

WORK SUPPORT

Support Item	Setting	Description
WIPER SPEED SETTING	Off*	Front wiper intermittent time linked with wiper dial position.
	On	Front wiper intermittent time linked with vehicle speed and wiper dial position.

* : Initial setting

A
B
C
D
E
F
G
H
I
J
K
L
M
N
O
P

WW

DIAGNOSIS SYSTEM (IPDM E/R)

< SYSTEM DESCRIPTION >

DIAGNOSIS SYSTEM (IPDM E/R)

Diagnosis Description

INFOID:000000011863127

AUTO ACTIVE TEST

Description

In auto active test mode, the IPDM E/R sends a drive signal to the following systems to check their operation:

- Oil pressure low/coolant pressure high warning indicator
- Oil pressure gauge
- Rear window defogger (if equipped)
- Front wipers (HI, LO)
- Tail, license and parking lamps
- Front fog lamps (if equipped)
- Headlamps (HI, LO)
- A/C compressor (magnetic clutch)

Operation Procedure

1. Close the hood and front door RH, and lift the wiper arms from the windshield (to prevent windshield damage due to wiper operation).
NOTE:
When auto active test is performed with hood opened, sprinkle water on windshield before hand.
2. Turn ignition switch OFF.
3. Turn the ignition switch ON and, within 20 seconds, press the front door switch LH 10 times. Then turn the ignition switch OFF.
4. Turn the ignition switch ON within 10 seconds. After that the horn sounds once and the auto active test starts.
5. After a series of the following operations is repeated 3 times, auto active test is completed.

NOTE:

When auto active test mode has to be cancelled halfway through test, turn ignition switch OFF.

CAUTION:

- If auto active test mode cannot be actuated, check door switch system. Refer to [DLK-26, "KING CAB : Description"](#) (King Cab) or [DLK-27, "CREW CAB : Description"](#) (Crew Cab).
- Do not start the engine.

Inspection in Auto Active Test Mode

When auto active test mode is actuated, the following 6 steps are repeated 3 times.

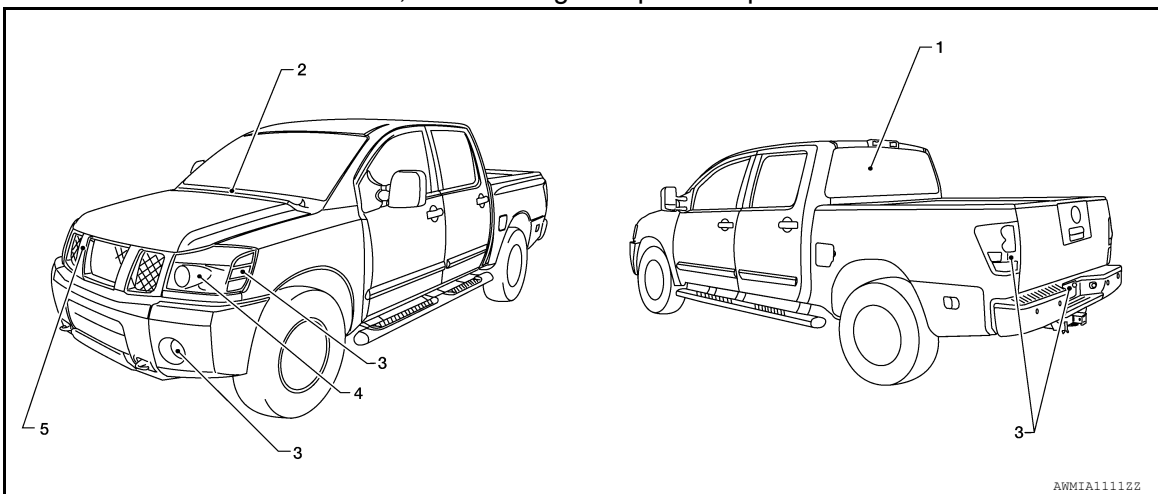

Operation sequence	Inspection Location	Operation
1	Rear window defogger (Crew Cab only)	10 seconds
2	Front wipers	LO for 5 seconds → HI for 5 seconds

DIAGNOSIS SYSTEM (IPDM E/R)

< SYSTEM DESCRIPTION >

Operation sequence	Inspection Location	Operation
3	Tail, license, parking lamps and front fog lamps (if equipped)	10 seconds
4	Headlamps	LO for 10 seconds → HI on-off for 5 seconds
5	A/C compressor (magnetic clutch)	ON ⇔ OFF 5 times

Concept of auto active test

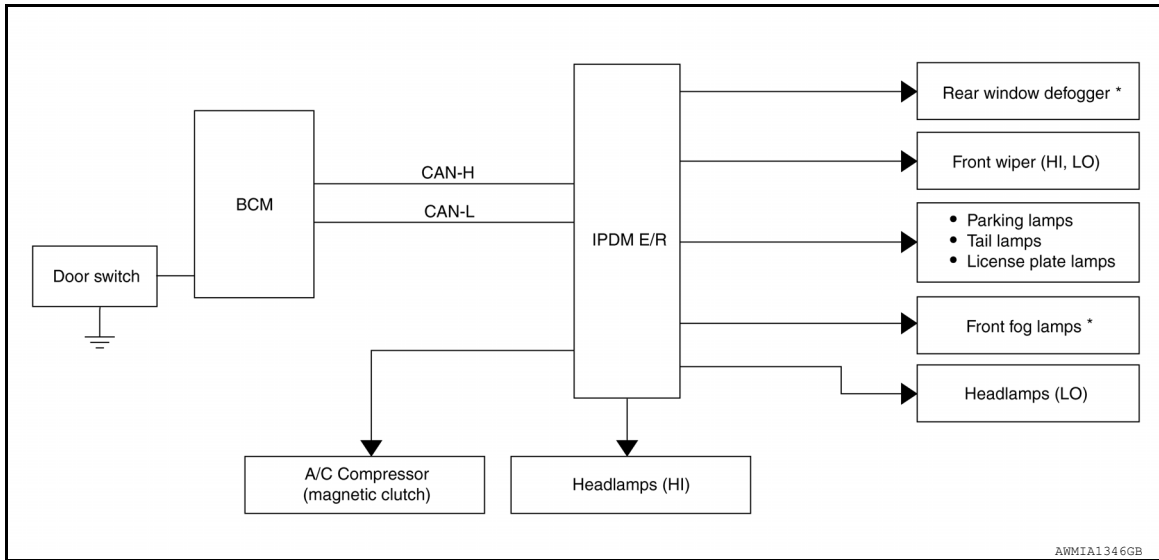

*: If equipped

- IPDM E/R starts the auto active test with the door switch signals transmitted by BCM via CAN communication. Therefore, the CAN communication line between IPDM E/R and BCM is considered normal if the auto active test starts successfully.
- The auto active test facilitates troubleshooting if any systems controlled by IPDM E/R cannot be operated.

Diagnosis chart in auto active test mode

Symptom	Inspection contents	Possible cause
Oil pressure low/coolant temperature high warning indicator does not operate	Perform auto active test. Does the oil pressure low/coolant temperature high warning indicator operate?	YES • IPDM E/R signal input circuit • ECM signal input circuit • CAN communication signal between ECM and combination meter
		NO CAN communication signal between IPDM E/R, BCM and combination meter
Oil pressure gauge does not operate	Perform auto active test. Does the oil pressure gauge operate?	YES IPDM E/R signal input circuit
		NO CAN communication signal between IPDM E/R, BCM and combination meter
Rear window defogger (if equipped) does not operate	Perform auto active test. Does the rear window defogger (if equipped) operate?	YES BCM signal input circuit
		NO CAN communication signal between BCM and IPDM E/R

DIAGNOSIS SYSTEM (IPDM E/R)

< SYSTEM DESCRIPTION >

Symptom	Inspection contents	Possible cause
Any of the following components do not operate: <ul style="list-style-type: none"> • Front wipers (HI, LO) • Tail lamps • License plate lamps • Parking lamps • Front fog lamps (if equipped) • Headlamps (HI, LO) 	Perform auto active test. Does the applicable system operate?	YES BCM signal input system
		NO <ul style="list-style-type: none"> • Lamp or front wiper motor malfunction • Lamp or front wiper motor ground circuit • Harness or connector between IPDM E/R and applicable system • IPDM E/R (integrated relay malfunction)
A/C compressor does not operate	Perform auto active test. Does the A/C compressor operate?	YES <ul style="list-style-type: none"> • BCM signal input circuit • CAN communication signal between BCM and ECM • CAN communication signal between ECM and IPDM E/R
		NO <ul style="list-style-type: none"> • Magnetic clutch malfunction • Harness or connector between IPDM E/R and magnetic clutch • IPDM E/R (integrated relay malfunction)

CONSULT Function (IPDM E/R)

INFOID:000000011863128

APPLICATION ITEM

CONSULT performs the following functions via CAN communication with IPDM E/R:

Direct Diagnostic Mode	Description
Self Diagnostic Result	The IPDM E/R self diagnostic results are displayed.
Data Monitor	The IPDM E/R input/output data is displayed in real time.
Active Test	The IPDM E/R activates outputs to test components.
CAN Diag Support Mntr	The result of transmit/receive diagnosis of CAN communication is displayed.

SELF DIAGNOSTIC RESULT

Refer to [PCS-22, "DTC Index"](#).

DATA MONITOR

Monitor Item [Unit]	Main Signals	Description
AC COMP REQ [On/Off]	×	Indicates A/C compressor request signal received from ECM on CAN communication line
TAIL&CLR REQ [On/Off]	×	Indicates position light request signal received from BCM on CAN communication line
HL LO REQ [On/Off]	×	Indicates low beam request signal received from BCM on CAN communication line
HL HI REQ [On/Off]	×	Indicates high beam request signal received from BCM on CAN communication line
FR FOG REQ [On/Off]	×	Indicates front fog light request signal received from BCM on CAN communication line
FR WIP REQ [Stop/1LOW/Low/Hi]	×	Indicates front wiper request signal received from BCM on CAN communication line
WIP AUTO STOP [STOP P/ACT P]	×	Indicates condition of front wiper auto stop signal
WIP PROT [Off/BLOCK]	×	Indicates condition of front wiper fail-safe operation
ST RLY REQ [On/Off]		Indicates starter request signal received from ECM on CAN communication line
IGN RLY [On/Off]	×	Indicates condition of ignition relay

DIAGNOSIS SYSTEM (IPDM E/R)

< SYSTEM DESCRIPTION >

Monitor Item [Unit]	Main Signals	Description
RR DEF REQ [On/Off]	×	Indicates rear defogger request signal received from AV control unit on CAN communication line
OIL P SW [Open/Close]		Indicates condition of oil pressure switch
DTRL REQ [Off]		Indicates daytime light request signal received from BCM on CAN communication line
THFT HRN REQ [On/Off]		Indicates theft warning horn request signal received from BCM on CAN communication line
HORN CHIRP [On/Off]		Indicates horn reminder signal received from BCM on CAN communication line

ACTIVE TEST

Test item	Description
REAR DEFOGGER	This test is able to check rear defogger operation [On/Off].
FRONT WIPER	This test is able to check wiper motor operation [Hi/Lo/Off].
EXTERNAL LAMPS	This test is able to check external lamp operation [Fog/Hi/Lo/TAIL/Off].
HORN	This test is able to check horn operation [On].

A
B
C
D
E
F
G
H
I
J
K
M
N
O
P

WW

WIPER AND WASHER FUSE

< DTC/CIRCUIT DIAGNOSIS >

DTC/CIRCUIT DIAGNOSIS

WIPER AND WASHER FUSE

Description

INFOID:0000000011559965

Fuse list

Unit	Location	Fuse No.	Capacity
Front wiper motor	IPDM E/R	39	30 A
Front washer motor	Fuse block (J/B)	9	10 A

Diagnosis Procedure

INFOID:0000000011559966

1. CHECK FUSES

Check that the following fuses are not blown.

Unit	Location	Fuse No.	Capacity
Front wiper motor	IPDM E/R	39	30 A
Front washer motor	Fuse block (J/B)	9	10 A

Is the fuse blown?

- YES >> Replace the fuse after repairing the affected circuit.
- NO >> The fuse is normal.

FRONT WIPER MOTOR LO CIRCUIT

< DTC/CIRCUIT DIAGNOSIS >

FRONT WIPER MOTOR LO CIRCUIT

Component Function Check

INFOID:0000000011559967

1. CHECK FRONT WIPER LO OPERATION

⊗ IPDM E/R AUTO ACTIVE TEST

1. Start IPDM E/R auto active test. Refer to [PCS-11, "Diagnosis Description"](#).
2. Check that the front wiper operates at the LO operation.

Ⓟ WITH CONSULT ACTIVE TEST

1. Select "FRONT WIPER" of IPDM E/R active test item.
2. While operating the test item, check front wiper operation.

LO : Front wiper (LO) operation

OFF : Stop the front wiper.

Is front wiper (LO) operation normal?

- YES >> Front wiper motor LO circuit is normal.
 NO >> Refer to [WW-15, "Diagnosis Procedure"](#).

Diagnosis Procedure

INFOID:0000000011559968

Regarding Wiring Diagram information, refer to [WW-42, "Wiring Diagram"](#).

1. CHECK FRONT WIPER MOTOR FUSE

1. Turn the ignition switch OFF.
2. Check that the following fuse is not blown.

Unit	Location	Fuse No.	Capacity
Front wiper motor	IPDM E/R	39	30 A

Is the fuse blown?

- YES >> Replace the fuse after repairing the affected circuit.
 NO >> GO TO 2.

2. CHECK FRONT WIPER MOTOR (LO) OUTPUT VOLTAGE

Ⓟ WITH CONSULT ACTIVE TEST

1. Turn the ignition switch ON.
2. Select "FRONT WIPER" of IPDM E/R active test item.
3. While operating the test item, check voltage between IPDM E/R harness connector and ground.

Terminals		Test item	Voltage (Approx.)
(+)	(-)		
IPDM E/R		FRONT WIPER	Battery voltage
Connector	Terminal		
E121	32	LO	Battery voltage
		OFF	0V

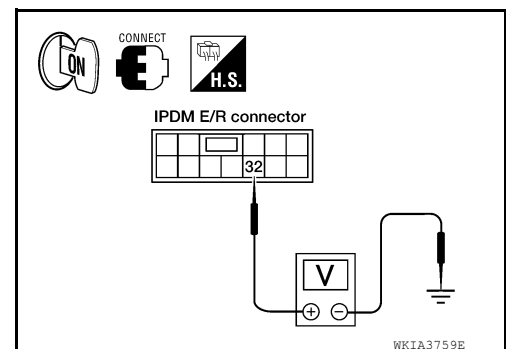

Is the measurement value normal?

- YES >> GO TO 3.
 NO >> Replace IPDM E/R. Refer to [PCS-28, "Removal and Installation of IPDM E/R"](#).

3. CHECK FRONT WIPER MOTOR (LO) OPEN CIRCUIT

A
B
C
D
E
F
G
H
I
J
K
M
N
O
P

WW

FRONT WIPER MOTOR LO CIRCUIT

< DTC/CIRCUIT DIAGNOSIS >

1. Turn the ignition switch OFF.
2. Disconnect IPDM E/R and front wiper motor.
3. Check continuity between IPDM E/R harness connector and front wiper motor harness connector.

IPDM E/R		Front wiper motor		Continuity
Connector	Terminal	Connector	Terminal	
E121	32	E23	3	Yes

Does continuity exist?

- YES >> Replace front wiper motor. Refer to [WW-54. "Wiper Motor and Linkage"](#).
- NO >> Repair or replace harness.

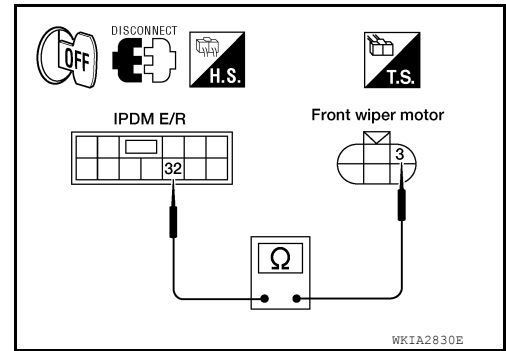

FRONT WIPER MOTOR HI CIRCUIT

< DTC/CIRCUIT DIAGNOSIS >

FRONT WIPER MOTOR HI CIRCUIT

Component Function Check

INFOID:0000000011559969

1. CHECK FRONT WIPER HI OPERATION

⊗ IPDM E/R AUTO ACTIVE TEST

1. Start IPDM E/R auto active test. Refer to [PCS-11, "Diagnosis Description"](#).
2. Check that the front wiper operates at the HI operation.

Ⓟ WITH CONSULT ACTIVE TEST

1. Select "FRONT WIPER" of IPDM E/R active test item.
2. While operating the test item, check front wiper operation.

HI : Front wiper (HI) operation

OFF : Stop the front wiper.

Is front wiper (HI) operation normal?

- YES >> Front wiper motor HI circuit is normal.
 NO >> Refer to [WW-17, "Diagnosis Procedure"](#).

Diagnosis Procedure

INFOID:0000000011559970

Regarding Wiring Diagram information, refer to [WW-42, "Wiring Diagram"](#).

1. CHECK FRONT WIPER MOTOR FUSE

1. Turn the ignition switch OFF.
2. Check that the following fuse is not blown.

Unit	Location	Fuse No.	Capacity
Front wiper motor	IPDM E/R	39	30 A

Is the fuse blown?

- YES >> Replace the fuse after repairing the affected circuit.
 NO >> GO TO 2.

2. CHECK FRONT WIPER MOTOR (HI) OUTPUT VOLTAGE

Ⓟ WITH CONSULT ACTIVE TEST

1. Turn the ignition switch ON.
2. Select "FRONT WIPER" of IPDM E/R active test item.
3. While operating the test item, check voltage between IPDM E/R harness connector and ground.

Terminals		Test item	Voltage (Approx.)
(+)	(-)		
IPDM E/R		FRONT WIPER	Battery voltage
Connector	Terminal		
E121	35	HI	Battery voltage
		OFF	0 V

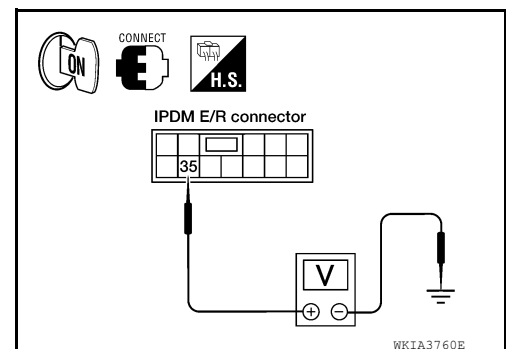

Is the measurement value normal?

- YES >> GO TO 3.
 NO >> Replace IPDM E/R. Refer to [PCS-28, "Removal and Installation of IPDM E/R"](#).

3. CHECK FRONT WIPER MOTOR (HI) OPEN CIRCUIT

A
B
C
D
E
F
G
H
I
J
K
M
N
O
P

WW

FRONT WIPER MOTOR HI CIRCUIT

< DTC/CIRCUIT DIAGNOSIS >

1. Turn the ignition switch OFF.
2. Disconnect IPDM E/R and front wiper motor.
3. Check continuity between IPDM E/R harness connector and front wiper motor harness connector.

IPDM E/R		Front wiper motor		Continuity
Connector	Terminal	Connector	Terminal	
E121	35	E23	2	Yes

Does continuity exist?

- YES >> Replace front wiper motor. Refer to [WW-54. "Wiper Motor and Linkage"](#).
- NO >> Repair or replace harness.

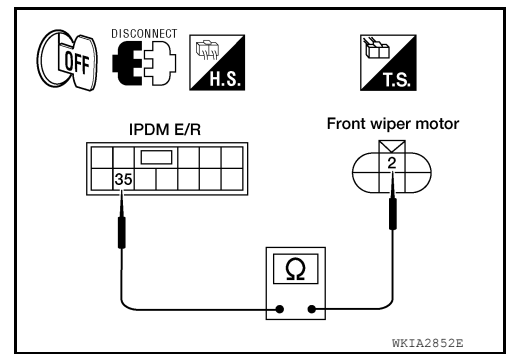

FRONT WIPER AUTO STOP SIGNAL CIRCUIT

< DTC/CIRCUIT DIAGNOSIS >

FRONT WIPER AUTO STOP SIGNAL CIRCUIT

Component Function Check

INFOID:0000000011559971

1. CHECK FRONT WIPER (AUTO STOP) SIGNAL

Ⓜ WITH CONSULT DATA MONITOR

1. Select "FR WIPER STOP" of BCM(WIPER) data monitor item.
2. Operate the front wiper.
3. Check that "FR WIPER STOP" changes to "ON" and "OFF" linked with the wiper operation.

Monitor item	Condition		Monitor status
FR WIPER STOP	Front wiper motor	Stop position	ON
		Except stop position	OFF

Is the status of item normal?

- YES >> Front wiper auto stop signal circuit is normal.
 NO >> Refer to [WW-19, "Diagnosis Procedure"](#).

Diagnosis Procedure

INFOID:0000000011559972

Regarding Wiring Diagram information, refer to [WW-42, "Wiring Diagram"](#).

1. CHECK IPDM E/R OUTPUT VOLTAGE

1. Turn the ignition switch OFF.
2. Disconnect front wiper motor.
3. Turn the ignition switch ON.
4. Check voltage between front wiper motor harness connector and ground.

Terminals		Voltage (Approx.)
(+)	(-)	
Front wiper motor		Battery voltage
Connector	Terminal	
E23	6	

Is the measurement value normal?

- YES >> Replace front wiper motor. Refer to [WW-54, "Wiper Motor and Linkage"](#)
 NO >> GO TO 2.

2. CHECK FRONT WIPER MOTOR (AUTO STOP) CIRCUIT CONTINUITY

1. Turn the ignition switch OFF.
2. Disconnect IPDM E/R connector E122.
3. Check continuity between IPDM E/R harness connector and front wiper motor harness connector.

IPDM E/R		Front wiper motor		Continuity
Connector	Terminal	Connector	Terminal	
E122	43	E23	6	Yes

4. Check continuity between IPDM E/R harness connector and ground.

IPDM E/R		Ground	Continuity
Connector	Terminal		
E122	43		No

Is the inspection result normal?

A
B
C
D
E
F
G
H
I
J
K
L
M
N
O
P

WW

FRONT WIPER AUTO STOP SIGNAL CIRCUIT

< DTC/CIRCUIT DIAGNOSIS >

- YES >> Replace IPDM E/R. Refer to [PCS-28. "Removal and Installation of IPDM E/R"](#).
- NO >> Repair or replace harness.

FRONT WIPER MOTOR GROUND CIRCUIT

< DTC/CIRCUIT DIAGNOSIS >

FRONT WIPER MOTOR GROUND CIRCUIT

Diagnosis Procedure

INFOID:000000011559973

Regarding Wiring Diagram information, refer to [WW-42. "Wiring Diagram"](#).

1. CHECK FRONT WIPER MOTOR (GROUND) OPEN CIRCUIT

1. Turn the ignition switch OFF.
2. Disconnect front wiper motor.
3. Check continuity between front wiper motor harness connector and ground.

Front wiper motor		Ground	Continuity
Connector	Terminal		
E23	1		Yes

Does continuity exist?

- YES >> Front wiper motor ground circuit is normal.
NO >> Repair or replace harness.

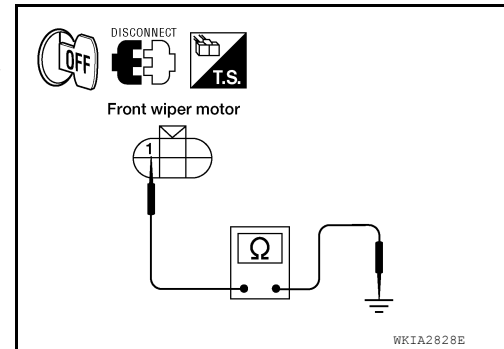

A
B
C
D
E
F
G
H
I
J
K
L
M
N
O
P

WW

WASHER SWITCH

< DTC/CIRCUIT DIAGNOSIS >

WASHER SWITCH

Description

INFOID:000000011559974

- Washer switch is integrated with combination switch (wiper and washer switch).
- Combination switch (wiper and washer switch) supplies ground and fuse # 9 from the fuse block supplies power for the front washer motor to operate.

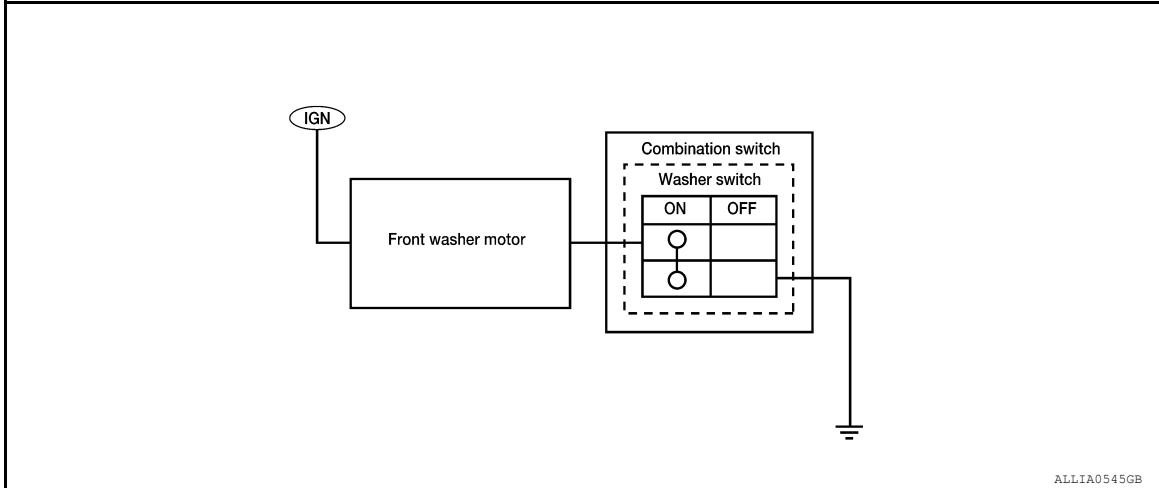

Component Inspection

INFOID:000000011559975

Regarding Wiring Diagram information, refer to [WW-42, "Wiring Diagram"](#).

1. CHECK WASHER SWITCH

1. Turn the ignition switch OFF.
2. Disconnect combination switch (wiper and washer switch).
3. Check continuity between the combination switch (wiper and washer switch) terminals.

A: Terminal 11
B: Terminal 12

	OFF	ON
A		○
B		○

ALLIA0546GB

Combination switch (wiper and washer switch)		Condition	Continuity
Terminal			
11	12	Washer switch ON	Yes

Does continuity exist?

YES >> Washer switch is normal.

NO >> Replace combination switch (wiper and washer switch). Refer to [WW-57, "Wiper and Washer Switch"](#).

WASHER MOTOR CIRCUIT

< DTC/CIRCUIT DIAGNOSIS >

WASHER MOTOR CIRCUIT

Diagnosis Procedure

INFOID:000000011559976

Regarding Wiring Diagram information, refer to [WW-42. "Wiring Diagram"](#).

1. CHECK FRONT WASHER MOTOR FUSE

1. Turn the ignition switch OFF.
2. Check that the following fuse is not blown.

Unit	Location	Fuse No.	Capacity
Front washer motor	Fuse block (J/B)	9	10A

Is the fuse blown?

- YES >> Replace the fuse after repairing the affected circuit.
NO >> GO TO 2.

2. CHECK FRONT WASHER MOTOR POWER SUPPLY

1. Disconnect front washer motor.
2. Turn ignition switch ON.
3. Check voltage between front washer motor harness connector and ground.

Terminals		Voltage (Approx.)
(+)	(-)	
Front washer motor		Battery voltage
Connector	Terminal	
E105	2	

Is the measurement value normal?

- YES >> GO TO 3.
NO >> Repair or replace harness.

3. CHECK FRONT WASHER MOTOR CIRCUIT CONTINUITY

1. Turn the ignition switch OFF.
2. Disconnect combination switch (wiper and washer switch).
3. Check continuity between combination switch (wiper and washer switch) harness connector and front washer motor.

Combination switch (wiper and washer switch)		Front washer motor		Continuity
Connector	Terminal	Connector	Terminal	
M28	11	E105	1	Yes

Does continuity exist?

- YES >> GO TO 4.
NO >> Repair or replace harness.

4. CHECK WIPER AND WASHER SWITCH GROUND CIRCUIT

Check continuity between combination switch (wiper and washer switch) harness connector and ground.

Combination switch (wiper and washer switch)		Ground	Continuity
Connector	Terminal		
M28	12		Yes

Does continuity exist?

A
B
C
D
E
F
G
H
I
J
K
L
M
N
O
P

WW

WASHER MOTOR CIRCUIT

< DTC/CIRCUIT DIAGNOSIS >

YES >> GO TO 5.

NO >> Repair or replace harness.

5. CHECK WIPER AND WASHER SWITCH

Check wiper and washer switch. Refer to [WW-22, "Component Inspection"](#).

Is the inspection result normal?

YES >> Replace front washer motor. Refer to [WW-58, "Washer Motor"](#).

NO >> Replace wiper and washer switch. Refer to [WW-57, "Wiper and Washer Switch"](#).

BCM (BODY CONTROL MODULE)

< ECU DIAGNOSIS INFORMATION >

ECU DIAGNOSIS INFORMATION

BCM (BODY CONTROL MODULE)

Reference Value

INFOID:0000000011863140

NOTE:

The Signal Tech II Tool [– (J-50190)] can be used to perform the following functions. Refer to the Signal Tech II User Guide for additional information:

- Activate and display TPMS transmitter IDs
- Display tire pressure reported by the TPMS transmitter
- Read TPMS DTCs
- Register TPMS transmitter IDs
- Test remote keyless entry keyfob relative signal strength

VALUES ON THE DIAGNOSIS TOOL

Monitor Item	Condition	Value/Status
ACC ON SW	Ignition switch OFF or ON	Off
	Ignition switch ACC	On
AIR COND SW	A/C switch OFF	Off
	A/C switch ON	On
AIR PRESS FL	Front left tire air pressure value	kPa, kg/cm ² , psi
AIR PRESS FR	Front right tire air pressure value	kPa, kg/cm ² , psi
AIR PRESS RL	Rear left tire air pressure value	kPa, kg/cm ² , psi
AIR PRESS RR	Rear right tire air pressure value	kPa, kg/cm ² , psi
AUTO LIGHT SW	Lighting switch OFF	Off
	Lighting switch AUTO	On
BRAKE SW	Brake pedal released	Off
	Brake pedal applied	On
BUCKLE SW	Seat belt buckle unfastened	Off
	Seat belt buckle fastened	On
BUZZER	Buzzer in combination meter OFF	Off
	Buzzer in combination meter ON	On
CARGO LAMP SW	Cargo lamp switch OFF	Off
	Cargo lamp switch ON	On
CDL LOCK SW	Door lock/unlock switch does not operate	Off
	Press door lock/unlock switch to the LOCK side	On
CDL UNLOCK SW	Door lock/unlock switch does not operate	Off
	Press door lock/unlock switch to the UNLOCK side	On
DOOR SW-AS	Front door RH closed	Off
	Front door RH opened	On
DOOR SW-DR	Front door LH closed	Off
	Front door LH opened	On
DOOR SW-RL	Rear door LH closed	Off
	Rear door LH opened	On
DOOR SW-RR	Rear door RH closed	Off
	Rear door RH opened	On

BCM (BODY CONTROL MODULE)

< ECU DIAGNOSIS INFORMATION >

Monitor Item	Condition	Value/Status
FAN ON SIG	Blower motor fan switch OFF	Off
	Blower motor fan switch ON	On
FR FOG SW	Front fog lamp switch OFF	Off
	Front fog lamp switch ON	On
FR WASHER SW	Front washer switch OFF	Off
	Front washer switch ON	On
FR WIPER LOW	Front wiper switch OFF	Off
	Front wiper switch LO	On
FR WIPER HI	Front wiper switch OFF	Off
	Front wiper switch HI	On
FR WIPER INT	Front wiper switch OFF	Off
	Front wiper switch INT	On
FR WIPER STOP	Any position other than front wiper stop position	Off
	Front wiper stop position	On
HAZARD SW	When hazard switch is not pressed	Off
	When hazard switch is pressed	On
HEAD LAMP SW1	Headlamp switch OFF	Off
	Headlamp switch 1st	On
HEAD LAMP SW2	Headlamp switch OFF	Off
	Headlamp switch 1st	On
HI BEAM SW	High beam switch OFF	Off
	High beam switch HI	On
ID REGST FL1	ID registration of front left tire incomplete	YET
	ID registration of front left tire complete	DONE
ID REGST FR1	ID registration of front right tire incomplete	YET
	ID registration of front right tire complete	DONE
ID REGST RL1	ID registration of rear left tire incomplete	YET
	ID registration of rear left tire complete	DONE
ID REGST RR1	ID registration of rear right tire incomplete	YET
	ID registration of rear right tire complete	DONE
IGN ON SW	Ignition switch OFF or ACC	Off
	Ignition switch ON	On
IGN SW CAN	Ignition switch OFF or ACC	Off
	Ignition switch ON	On
INT VOLUME	Wiper intermittent dial is in a dial position 1 - 7	1 - 7
KEY CYL LK-SW	Door key cylinder LOCK position	Off
	Door key cylinder other than LOCK position	On
KEY CYL UN-SW	Door key cylinder UNLOCK position	Off
	Door key cylinder other than UNLOCK position	On
KEY ON SW	Mechanical key is removed from key cylinder	Off
	Mechanical key is inserted to key cylinder	On
KEYLESS LOCK	LOCK button of key fob is not pressed	Off
	LOCK button of key fob is pressed	On

BCM (BODY CONTROL MODULE)

< ECU DIAGNOSIS INFORMATION >

Monitor Item	Condition	Value/Status	
KEYLESS PANIC	PANIC button of key fob is not pressed	Off	A
	PANIC button of key fob is pressed	On	
KEYLESS UNLOCK	UNLOCK button of key fob is not pressed	Off	B
	UNLOCK button of key fob is pressed	On	
LIGHT SW 1ST	Lighting switch OFF	Off	C
	Lighting switch 1st	On	
OIL PRESS SW	<ul style="list-style-type: none"> • Ignition switch OFF or ACC • Engine running 	Off	D
	Ignition switch ON	On	
OPTICAL SENSOR	Bright outside of the vehicle	Close to 5V	E
	Dark outside of the vehicle	Close to 0V	
PASSING SW	Other than lighting switch PASS	Off	F
	Lighting switch PASS	On	
REAR DEF SW	Rear window defogger switch OFF	Off	G
	Rear window defogger switch ON	On	
TURN SIGNAL L	Turn signal switch OFF	Off	H
	Turn signal switch LH	On	
TURN SIGNAL R	Turn signal switch OFF	Off	I
	Turn signal switch RH	On	
VEHICLE SPEED	While driving	Equivalent to speedometer reading	J
WARNING LAMP	Low tire pressure warning lamp in combination meter OFF	Off	K
	Low tire pressure warning lamp in combination meter ON	On	

WW

M

N

O

P

BCM (BODY CONTROL MODULE)

< ECU DIAGNOSIS INFORMATION >

Terminal Layout

INFOID:000000011863141

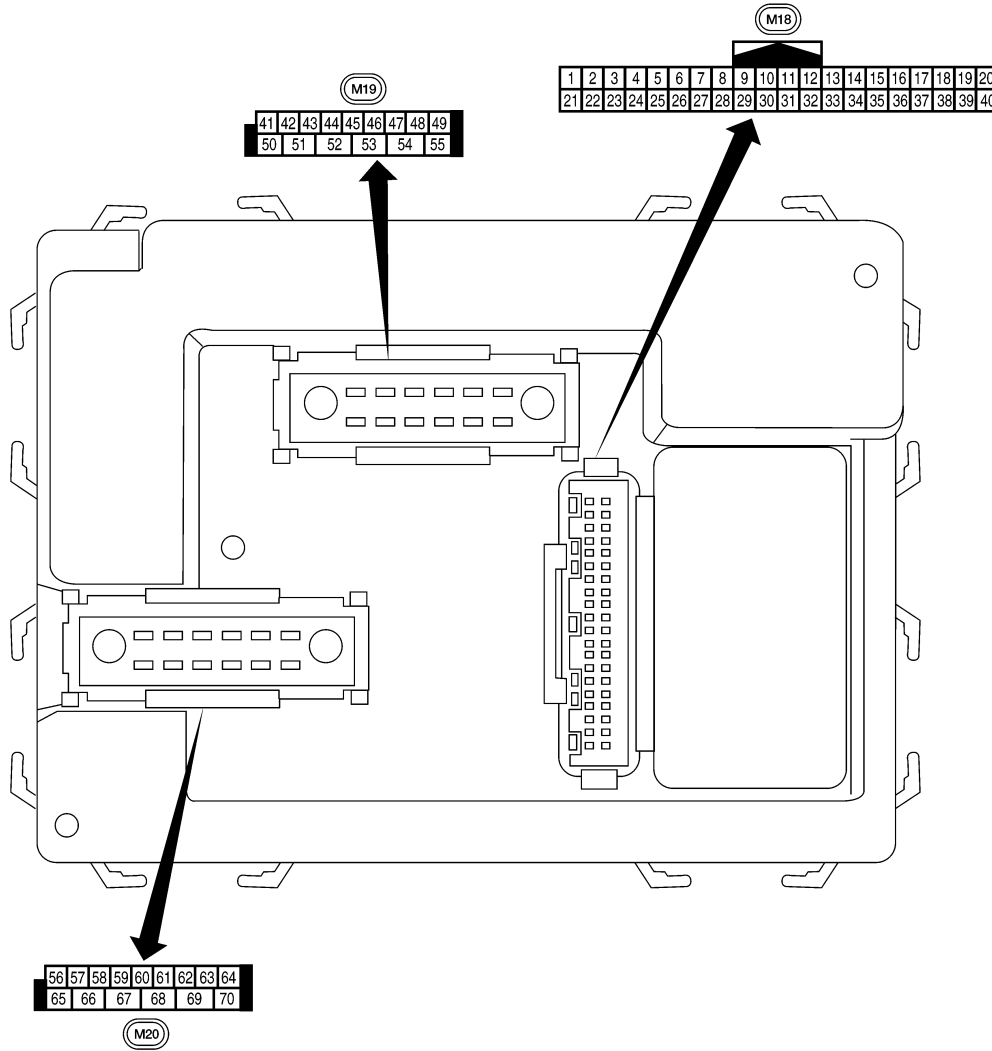

Physical Values

AWMIA15422Z

INFOID:000000011863142

BCM (BODY CONTROL MODULE)

< ECU DIAGNOSIS INFORMATION >

Terminal	Wire color	Signal name	Signal input/output	Measuring condition		Reference value or waveform (Approx.)
				Ignition switch	Operation or condition	
1	BR/W	Key ring output	Output	OFF	ON (driver door open)	0V
					OFF (driver door closed)	Battery voltage
2	SB	Combination switch input 5	Input	ON	Lighting, turn, wiper OFF Wiper dial position 4	<p style="text-align: right; font-size: small;">SKIA5291E</p>
3	G/Y	Combination switch input 4	Input	ON	Lighting, turn, wiper OFF Wiper dial position 4	<p style="text-align: right; font-size: small;">SKIA5292E</p>
4	Y	Combination switch input 3	Input	ON	Lighting, turn, wiper OFF Wiper dial position 4	<p style="text-align: right; font-size: small;">SKIA5291E</p>
5	G/B	Combination switch input 2	Input	ON	Lighting, turn, wiper OFF Wiper dial position 4	<p style="text-align: right; font-size: small;">SKIA5292E</p>
6	V	Combination switch input 1				
9	R/G	Brake switch	Input	ON	Brake pedal depressed	Battery voltage
					Brake pedal released	0V
11	O	Ignition switch (ACC or ON)	Input	ACC or ON	Ignition switch ACC or ON	Battery voltage
12	R/L	Front door switch RH (All)	Input	OFF	ON (open)	0V
		Rear door switch lower RH (King Cab)			OFF (closed)	Battery voltage
		Rear door switch upper RH (King Cab)				
13	GR	Rear door switch RH (Crew Cab)	Input	OFF	ON (open)	0V
					OFF (closed)	Battery voltage
15	L/W	Tire pressure warning check connector	Input	OFF	—	5V
18	P	Remote keyless entry receiver and optical sensor (ground)	Output	OFF	—	0V

A
B
C
D
E
F
G
H
I
J
K

WW

M
N
O
P

BCM (BODY CONTROL MODULE)

< ECU DIAGNOSIS INFORMATION >

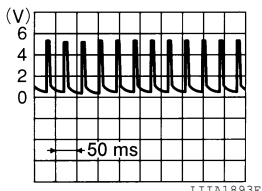
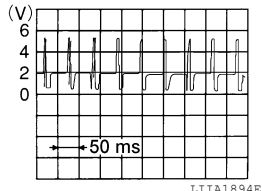
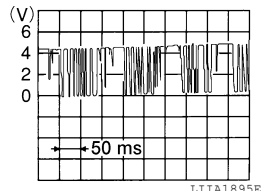
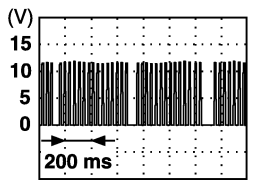
Terminal	Wire color	Signal name	Signal input/output	Measuring condition		Reference value or waveform (Approx.)
				Ignition switch	Operation or condition	
19	V/W	Remote keyless entry receiver (power supply)	Output	OFF	Ignition switch OFF	 <p style="text-align: right; font-size: small;">L1TA1895E</p>
20	G/W	Remote keyless entry receiver (signal)	Input	OFF	Stand-by (keyfob buttons released)	 <p style="text-align: right; font-size: small;">L1TA1894E</p>
					When remote keyless entry receiver receives signal from keyfob (keyfob buttons pressed)	 <p style="text-align: right; font-size: small;">L1TA1895E</p>
21	G	NATS antenna amp.	Input	OFF → ON	Ignition switch (OFF → ON)	Just after turning ignition switch ON: Pointer of tester should move for approx. 1 second, then return to battery voltage.
22	G	BUS	—	—	Ignition switch ON or power window timer operates	 <p style="text-align: right; font-size: small;">P1TA2344E</p>
23	G/O	Security indicator lamp	Output	OFF	Goes OFF → illuminates (Every 2.4 seconds)	Battery voltage → 0V
25	BR	NATS antenna amp.	Input	OFF → ON	Ignition switch (OFF → ON)	Just after turning ignition switch ON: Pointer of tester should move for approx. 1 second, then return to battery voltage.
27	W/R	Compressor ON signal	Input	ON	A/C switch OFF	5V
					A/C switch ON	0V
28	L/R	Front blower monitor	Input	ON	Front blower motor OFF	Battery voltage
					Front blower motor ON	0V
29	W/B	Hazard switch	Input	OFF	ON	0V
					OFF	5V
31	P/L	Cargo lamp switch	Input	OFF	Cargo lamp switch ON	0
					Cargo lamp switch OFF	Battery voltage

BCM (BODY CONTROL MODULE)

< ECU DIAGNOSIS INFORMATION >

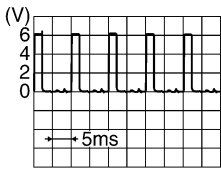
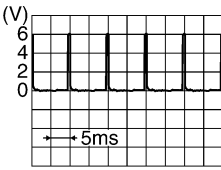
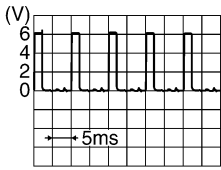
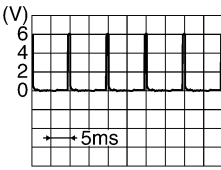
Terminal	Wire color	Signal name	Signal input/output	Measuring condition		Reference value or waveform (Approx.)
				Ignition switch	Operation or condition	
32	R/G	Combination switch output 5	Output	ON	Lighting, turn, wiper OFF Wiper dial position 4	 <small>SKIA5291E</small>
33	R/Y	Combination switch output 4	Output	ON	Lighting, turn, wiper OFF Wiper dial position 4	 <small>SKIA5292E</small>
34	L	Combination switch output 3	Output	ON	Lighting, turn, wiper OFF Wiper dial position 4	 <small>SKIA5291E</small>
35	O/B	Combination switch output 2	Output	ON	Lighting, turn, wiper OFF Wiper dial position 4	 <small>SKIA5292E</small>
36	R/W	Combination switch output 1				
37	B/R	Key switch and key lock solenoid	Input	OFF	Key inserted	Battery voltage
					Key removed	0V
38	W/L	Ignition switch (ON)	Input	ON	—	Battery voltage
39	L	CAN-H	—	—	—	—
40	P	CAN-L	—	—	—	—
41	Y/B	Rear defogger switch	Input	ON	Rear defogger switch ON	0V
					Rear defogger switch OFF	5V
47	SB	Front door switch LH (All)	Input	OFF	ON (open)	0V
		Rear door switch lower LH (King Cab)				
		Rear door switch upper LH (King Cab)				
48	R/Y	Rear door switch LH (Crew Cab)	Input	OFF	ON (open)	0V
					OFF (closed)	Battery voltage
50	R/Y	Cargo bed lamp control	Output	OFF	Cargo lamp switch (ON)	0V
					Cargo lamp switch (OFF)	Battery voltage

BCM (BODY CONTROL MODULE)

< ECU DIAGNOSIS INFORMATION >

Terminal	Wire color	Signal name	Signal input/output	Measuring condition		Reference value or waveform (Approx.)
				Ignition switch	Operation or condition	
51	Y/B	Trailer turn signal (right)	Output	ON	Turn right ON	<p style="text-align: right; font-size: small;">SKIA3009J</p>
52	G/B	Trailer turn signal (left)	Output	ON	Turn left ON	<p style="text-align: right; font-size: small;">SKIA3009J</p>
56	R/G	Battery saver output	Output	OFF	15 minutes after ignition switch is turned OFF	0V
				ON	—	Battery voltage
57	Y/R	Battery power supply	Input	OFF	—	Battery voltage
58	W/R	Optical sensor	Input	ON	When optical sensor is illuminated	3.1V or more
					When optical sensor is not illuminated	0.6V or less
59	G	Front door lock assembly LH actuator (unlock)	Output	OFF	OFF (neutral)	0V
					ON (unlock)	Battery voltage
60	G/B	Turn signal (left)	Output	ON	Turn left ON	<p style="text-align: right; font-size: small;">SKIA3009J</p>
61	G/Y	Turn signal (right)	Output	ON	Turn right ON	<p style="text-align: right; font-size: small;">SKIA3009J</p>
63	L	Interior room/map lamp	Output	OFF	Any door switch ON (open)	0V
					OFF (closed)	Battery voltage
65	V	All door lock actuators (lock)	Output	OFF	OFF (neutral)	0V
					ON (lock)	Battery voltage
66	G/Y	Front door lock actuator RH and rear door lock actuators LH/RH (unlock)	Output	OFF	OFF (neutral)	0V
					ON (unlock)	Battery voltage
67	B	Ground	Input	ON	—	0V

BCM (BODY CONTROL MODULE)

< ECU DIAGNOSIS INFORMATION >

Terminal	Wire color	Signal name	Signal input/output	Measuring condition		Reference value or waveform (Approx.)
				Ignition switch	Operation or condition	
68	W/L	Power window power supply (RAP)	Output	—	Ignition switch ON	Battery voltage
					Within 45 seconds after ignition switch OFF	Battery voltage
					More than 45 seconds after ignition switch OFF	0V
					When front door LH or RH is open or power window timer operates	0V
69	W/R	Power window power supply	Output	—	—	Battery voltage
70	W/B	Battery power supply	Input	OFF	—	Battery voltage

Fail Safe

INFOID:0000000011863144

Fail-safe index

BCM performs fail-safe control when any DTC listed below is detected.

Display contents of CONSULT	Fail-safe	Cancellation
U1000: CAN COMM CIRCUIT	Inhibit engine cranking	When the BCM re-establishes communication with the other modules.

DTC Inspection Priority Chart

INFOID:0000000011863144

If some DTCs are displayed at the same time, perform inspections one by one based on the following priority chart:

Priority	DTC
1	<ul style="list-style-type: none"> U1000: CAN COMM CIRCUIT
2	<ul style="list-style-type: none"> B2190: NATS ANTENNA AMP B2191: DIFFERENCE OF KEY B2192: ID DISCORD BCM-ECM B2193: CHAIN OF BCM-ECM

WW

BCM (BODY CONTROL MODULE)

< ECU DIAGNOSIS INFORMATION >

Priority	DTC
3	<ul style="list-style-type: none"> • C1729: VHCL SPEED SIG ERR • C1735: IGNITION SIGNAL
4	<ul style="list-style-type: none"> • C1704: LOW PRESSURE FL • C1705: LOW PRESSURE FR • C1706: LOW PRESSURE RR • C1707: LOW PRESSURE RL • C1708: [NO DATA] FL • C1709: [NO DATA] FR • C1710: [NO DATA] RR • C1711: [NO DATA] RL • C1712: [CHECKSUM ERR] FL • C1713: [CHECKSUM ERR] FR • C1714: [CHECKSUM ERR] RR • C1715: [CHECKSUM ERR] RL • C1716: [PRESSDATA ERR] FL • C1717: [PRESSDATA ERR] FR • C1718: [PRESSDATA ERR] RR • C1719: [PRESSDATA ERR] RL • C1720: [CODE ERR] FL • C1721: [CODE ERR] FR • C1722: [CODE ERR] RR • C1723: [CODE ERR] RL • C1724: [BATT VOLT LOW] FL • C1725: [BATT VOLT LOW] FR • C1726: [BATT VOLT LOW] RR • C1727: [BATT VOLT LOW] RL

DTC Index

INFOID:000000011863145

NOTE:

Details of time display

- CRNT: Displays when there is a malfunction now or after returning to the normal condition until turning ignition switch OFF → ON again.
- 1 - 39: Displayed if any previous malfunction is present when current condition is normal. It increases like 1 → 2 → 3...38 → 39 after returning to the normal condition whenever ignition switch OFF → ON. The counter remains at 39 even if the number of cycles exceeds it. It is counted from 1 again when turning ignition switch OFF → ON after returning to the normal condition if the malfunction is detected again.

CONSULT display	Fail-safe	Tire pressure monitor warning lamp ON	Reference page
No DTC is detected. further testing may be required.	—	—	—
U1000: CAN COMM CIRCUIT	—	—	BCS-30
B2190: NATS ANTENA AMP	—	—	SEC-18
B2191: DIFFERENCE OF KEY	—	—	SEC-21
B2192: ID DISCORD BCM-ECM	—	—	SEC-22
B2193: CHAIN OF BCM-ECM	—	—	SEC-24
C1708: [NO DATA] FL	—	—	WT-15
C1709: [NO DATA] FR	—	—	WT-15
C1710: [NO DATA] RR	—	—	WT-15
C1711: [NO DATA] RL	—	—	WT-15
C1712: [CHECKSUM ERR] FL	—	—	WT-17
C1713: [CHECKSUM ERR] FR	—	—	WT-17
C1714: [CHECKSUM ERR] RR	—	—	WT-17
C1715: [CHECKSUM ERR] RL	—	—	WT-17

BCM (BODY CONTROL MODULE)

< ECU DIAGNOSIS INFORMATION >

CONSULT display	Fail-safe	Tire pressure monitor warning lamp ON	Reference page
C1716: [PRESSDATA ERR] FL	—	—	WT-19
C1717: [PRESSDATA ERR] FR	—	—	WT-19
C1718: [PRESSDATA ERR] RR	—	—	WT-19
C1719: [PRESSDATA ERR] RL	—	—	WT-19
C1720: [CODE ERR] FL	—	—	WT-17
C1721: [CODE ERR] FR	—	—	WT-17
C1722: [CODE ERR] RR	—	—	WT-17
C1723: [CODE ERR] RL	—	—	WT-17
C1724: [BATT VOLT LOW] FL	—	—	WT-17
C1725: [BATT VOLT LOW] FR	—	—	WT-17
C1726: [BATT VOLT LOW] RR	—	—	WT-17
C1727: [BATT VOLT LOW] RL	—	—	WT-17
C1729: VHCL SPEED SIG ERR	—	—	WT-21
C1735: IGNITION SIGNAL	—	—	WT-23

A
B
C
D
E
F
G
H
I
J
K
M
N
O
P

WW

IPDM E/R (INTELLIGENT POWER DISTRIBUTION MODULE ENGINE ROOM)

< ECU DIAGNOSIS INFORMATION >

IPDM E/R (INTELLIGENT POWER DISTRIBUTION MODULE ENGINE ROOM)

Reference Value

INFOID:000000011863146

VALUES ON THE DIAGNOSIS TOOL

Monitor Item	Condition		Value/Status
A/C COMP REQ	A/C switch OFF		Off
	A/C switch ON		On
TAIL&CLR REQ	Lighting switch OFF		Off
	Lighting switch 1ST, 2ND, HI or AUTO (Light is illuminated)		On
HL LO REQ	Lighting switch OFF		Off
	Lighting switch 2ND HI or AUTO (Light is illuminated)		On
HL HI REQ	Lighting switch OFF		Off
	Lighting switch HI		On
FR FOG REQ	Lighting switch 2ND or AUTO (Light is illuminated)	Front fog lamp switch OFF	Off
		<ul style="list-style-type: none"> • Front fog lamp switch ON • Daytime light activated (Canada only) 	On
FR WIP REQ	Ignition switch ON	Front wiper switch OFF	Stop
		Front wiper switch INT	1LOW
		Front wiper switch LO	Low
		Front wiper switch HI	Hi
WIP AUTO STOP	Ignition switch ON	Front wiper stop position	STOP P
		Any position other than front wiper stop position	ACT P
WIP PROT	Ignition switch ON	Front wiper operates normally	Off
		Front wiper stops at fail-safe operation	BLOCK
ST RLY REQ	Ignition switch OFF or ACC		Off
	Ignition switch START		On
IGN RLY	Ignition switch OFF or ACC		Off
	Ignition switch ON		On
RR DEF REQ	Rear defogger switch OFF		Off
	Rear defogger switch ON		On
OIL P SW	Ignition switch OFF, ACC or engine running		Open
	Ignition switch ON		Close
DTRL REQ	Not operated		Off
	Daytime Running Lights ON		On
THFT HRN REQ	Not operated		Off
	<ul style="list-style-type: none"> • Panic alarm is activated • Horn is activated with VEHICLE SECURITY (THEFT WARNING) SYSTEM 		On
HORN CHIRP	Not operated		Off
	Door locking with keyfob (horn chirp mode)		On

IPDM E/R (INTELLIGENT POWER DISTRIBUTION MODULE ENGINE ROOM)

< ECU DIAGNOSIS INFORMATION >

Terminal Layout

INFOID:000000011863147

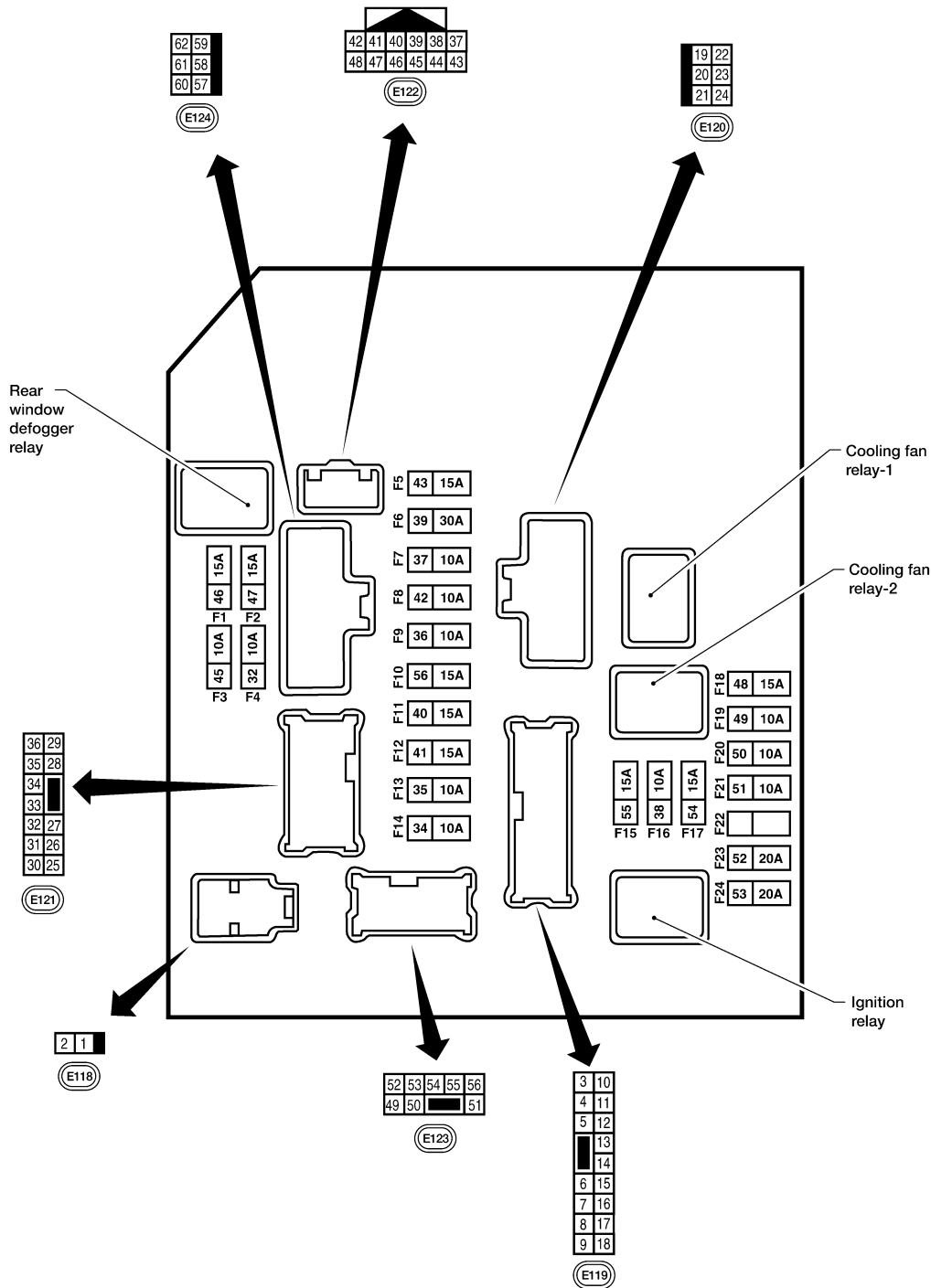

NOTE:

Numbers preceded by an "F" represent the fuse numbers imprinted on the IPDM E/R. The other numbers represent the fuse numbers as they appear in the wiring diagrams.

Physical Values

PHYSICAL VALUES

AAMIA0386GB

INFOID:000000011863148

IPDM E/R (INTELLIGENT POWER DISTRIBUTION MODULE ENGINE ROOM)

< ECU DIAGNOSIS INFORMATION >

Terminal	Wire color	Signal name	Signal input/output	Measuring condition		Reference value (Approx.)	
				Ignition switch	Operation or condition		
1	B/Y	Battery power supply	Input	OFF	—	Battery voltage	
2	R	Battery power supply	Input	OFF	—	Battery voltage	
3	BR	ECM relay	Output	—	Ignition switch ON or START	Battery voltage	
					Ignition switch OFF or ACC	0V	
4	W/L	ECM relay	Output	—	Ignition switch ON or START	Battery voltage	
					Ignition switch OFF or ACC	0V	
6	L	Throttle control motor relay	Output	—	Ignition switch ON or START	Battery voltage	
					Ignition switch OFF or ACC	0V	
7	W/B	ECM relay control	Input	—	Ignition switch ON or START	0V	
					Ignition switch OFF or ACC	Battery voltage	
8	R/B	Fuse 54	Output	—	Ignition switch ON or START	Battery voltage	
					Ignition switch OFF or ACC	0V	
10	G	Fuse 45 (Canada only)	Output	ON	Daytime light system active	0V	
					Daytime light system inactive	Battery voltage	
11	Y/B	A/C compressor	Output	ON or START	A/C switch ON or defrost A/C switch	Battery voltage	
					A/C switch OFF or defrost A/C switch	0V	
12	L/W	Ignition switch supplied power	Input	—	OFF or ACC	0V	
					ON or START	Battery voltage	
13	B/Y	Fuel pump relay	Output	—	Ignition switch ON or START	Battery voltage	
					Ignition switch OFF or ACC	0V	
14	Y/R	Fuse 49	Output	—	Ignition switch ON or START	Battery voltage	
					Ignition switch OFF or ACC	0V	
15	LG/B	Fuse 50	Output	—	Ignition switch ON or START	Battery voltage	
					Ignition switch OFF or ACC	0V	
16	G	Fuse 51	Output	—	Ignition switch ON or START	Battery voltage	
					Ignition switch OFF or ACC	0V	
17	W	Fuse 55	Output	—	Ignition switch ON or START	Battery voltage	
					Ignition switch OFF or ACC	0V	
19	W/R	Starter motor	Output	START	—	Battery voltage	
21	BR	Ignition switch supplied power	Input	—	OFF or ACC	0V	
					START	Battery voltage	
22	G	Battery power supply	Output	OFF	—	Battery voltage	
23	GR/W	Door mirror defogger output signal (if equipped)	Output	—	When rear defogger switch is ON	Battery voltage	
					When rear defogger switch is OFF	0V	
27	W/B	Fuse 38	Output	—	Ignition switch ON or START	Battery voltage	
					Ignition switch OFF or ACC	0V	
30	W	Fuse 53	Output	—	Ignition switch ON or START	Battery voltage	
					Ignition switch OFF or ACC	0V	
32	L	Wiper low speed signal	Output	ON or START	Wiper switch	OFF	0V
						LO or INT	Battery voltage

IPDM E/R (INTELLIGENT POWER DISTRIBUTION MODULE ENGINE ROOM)

< ECU DIAGNOSIS INFORMATION >

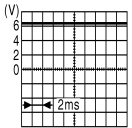
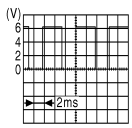
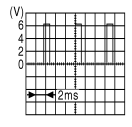
Terminal	Wire color	Signal name	Signal input/output	Measuring condition		Reference value (Approx.)	
				Ignition switch	Operation or condition		
35	L/B	Wiper high speed signal	Output	ON or START	Wiper switch	OFF, LO, INT	
						HI	
37	Y	Power generation command signal	Output	—	Ignition switch ON	 <small>JPMIA0001GB</small> 6.3 V	
						40% is set on "Active test," "ALTERNATOR DUTY" of "ENGINE"	 <small>JPMIA0002GB</small> 3.8 V
						40% is set on "Active test," "ALTERNATOR DUTY" of "ENGINE"	 <small>JPMIA0003GB</small> 1.4 V
38	B	Ground	Input	—	—	0V	
39	L	CAN-H	—	ON	—	—	
40	P	CAN-L	—	ON	—	—	
42	GR	Oil pressure switch	Input	—	Engine running	Battery voltage	
					Engine stopped	0V	
43	L/Y	Wiper auto stop signal	Input	ON or START	Wiper switch	OFF, LO, INT	
44	BR	Daytime light relay control (Canada only)	Input	ON	Daytime light system active	0V	
					Daytime light system inactive	Battery voltage	
45	G/W	Horn relay control	Input	ON	When door locks are operated using keyfob (OFF → ON)*	Battery voltage → 0V	
46	GR	Fuel pump relay control	Input	—	Ignition switch ON or START	0V	
					Ignition switch OFF or ACC	Battery voltage	
47	O	Throttle control motor relay control	Input	—	Ignition switch ON or START	0V	
					Ignition switch OFF or ACC	Battery voltage	
48	B/R	Starter relay (inhibit switch)	Input	ON or START	Selector lever in "P" or "N"	0V	
					Selector lever any other position	Battery voltage	
49	R/L	Trailer tow relay illumination	Output	ON	Lighting switch must be in the 1st position	OFF	
					ON	Battery voltage	

A
B
C
D
E
F
G
H
I
J
K

WW

M
N
O
P

IPDM E/R (INTELLIGENT POWER DISTRIBUTION MODULE ENGINE ROOM)

< ECU DIAGNOSIS INFORMATION >

Terminal	Wire color	Signal name	Signal input/output	Measuring condition		Reference value (Approx.)
				Ignition switch	Operation or condition	
50	W/R	Front fog lamp (LH) (if equipped)	Output	ON or START	Lighting switch must be in the 2nd position (LOW beam is ON) and the front fog lamp switch	0V
					OFF	Battery voltage
51	W/R	Front fog lamp (RH) (if equipped)	Output	ON or START	Lighting switch must be in the 2nd position (LOW beam is ON) and the front fog lamp switch	0V
					OFF	Battery voltage
52	L	LH low beam headlamp	Output	—	Lighting switch in 2nd position	Battery voltage
54	R/Y	RH low beam headlamp	Output	—	Lighting switch in 2nd position	Battery voltage
55	G	LH high beam headlamp	Output	—	Lighting switch in 2nd position and placed in HIGH or PASS position	Battery voltage
56	Y (With DTRL) L/W (Without DTRL)	RH high beam headlamp	Output	—	Lighting switch in 2nd position and placed in HIGH or PASS position	Battery voltage
57	R/L	Parking, license and tail lamp	Output	ON	Lighting switch 1st position	0V
						Battery voltage
59	B	Ground	Input	—	—	0V
60	B/W	Rear window defogger relay (if equipped)	Output	ON or START	Rear defogger switch ON	Battery voltage
					Rear defogger switch OFF	0V
61	BR	Fuse 32	Output	OFF	—	Battery voltage

*: When horn reminder is ON

Fail Safe

INFOID:000000011863149

CAN COMMUNICATION CONTROL

When CAN communication with ECM and BCM is impossible, IPDM E/R performs fail-safe control. After CAN communication recovers normally, it also returns to normal control.

If No CAN Communication Is Available With BCM

Control part	Fail-safe in operation
Headlamp	<ul style="list-style-type: none"> • Turns ON the headlamp low relay when the ignition switch is turned ON • Turns OFF the headlamp low relay when the ignition switch is turned OFF • Headlamp high relay OFF
<ul style="list-style-type: none"> • Parking lamps • License plate lamps • Tail lamps 	<ul style="list-style-type: none"> • Turns ON the tail lamp relay when the ignition switch is turned ON • Turns OFF the tail lamp relay when the ignition switch is turned OFF
Front wiper	<ul style="list-style-type: none"> • The status just before activation of fail-safe control is maintained until the ignition switch is turned OFF while the front wiper is operating at LO or HI speed. • The wiper is operated at LO speed until the ignition switch is turned OFF if the fail-safe control is activated while the front wiper is set in the INT mode and the front wiper motor is operating.
Rear window defogger (if equipped)	Rear window defogger relay OFF

IPDM E/R (INTELLIGENT POWER DISTRIBUTION MODULE ENGINE ROOM)

< ECU DIAGNOSIS INFORMATION >

Control part	Fail-safe in operation
A/C compressor	A/C relay OFF
Front fog lamps (if equipped)	Front fog lamp relay OFF

IGNITION RELAY MALFUNCTION DETECTION FUNCTION

- IPDM E/R monitors the voltage at the contact circuit and excitation coil circuit of the ignition relay inside it.
- IPDM E/R judges the ignition relay error if the voltage differs between the contact circuit and the excitation coil circuit.
- If the ignition relay cannot turn OFF due to contact seizure, it activates the tail lamp relay for 10 minutes to alert the user to the ignition relay malfunction when the ignition switch is turned OFF.

Ignition switch	Ignition relay	Tail lamp relay
ON	ON	—
OFF	OFF	—

NOTE:

The tail lamp turns OFF when the ignition switch is turned ON.

FRONT WIPER CONTROL

IPDM E/R detects front wiper stop position by a front wiper auto stop signal.

When a front wiper auto stop signal is in the conditions listed below, IPDM E/R stops power supply to wiper after repeating a front wiper 10 seconds activation and 20 seconds stop five times.

Ignition switch	Front wiper switch	Auto stop signal
ON	OFF	Front wiper stop position signal cannot be input 10 seconds.
	ON	The signal does not change for 10 seconds.

NOTE:

This operation status can be confirmed on the IPDM E/R “DATA MONITOR” that displays “Block” for the item “WIP PROT” while the wiper is stopped.

STARTER MOTOR PROTECTION FUNCTION

IPDM E/R turns OFF the starter control relay to protect the starter motor when the starter control relay remains active for 90 seconds.

DTC Index

INFOID:000000011863150

CONSULT display	Fail-safe	TIME ^{NOTE}		Refer to
No DTC is detected. further testing may be required.	—	—	—	—
U1000: CAN COMM CIRCUIT	×	CRNT	1 – 39	PCS-15

NOTE:

The details of TIME display are as follows.

- CRNT: The malfunctions that are detected now
- 1 - 39: The number is indicated when it is normal at present and a malfunction was detected in the past. It increases like 0 → 1 → 2 ... 38 → 39 after returning to the normal condition whenever IGN OFF → ON. It is fixed to 39 until the self-diagnosis results are erased if it is over 39. It returns to 0 when a malfunction is detected again in the process.

A
B
C
D
E
F
G
H
I
J
K
M
N
O
P

WW

FRONT WIPER AND WASHER SYSTEM

< WIRING DIAGRAM >

WIRING DIAGRAM

FRONT WIPER AND WASHER SYSTEM

Wiring Diagram

INFOID:000000011559988

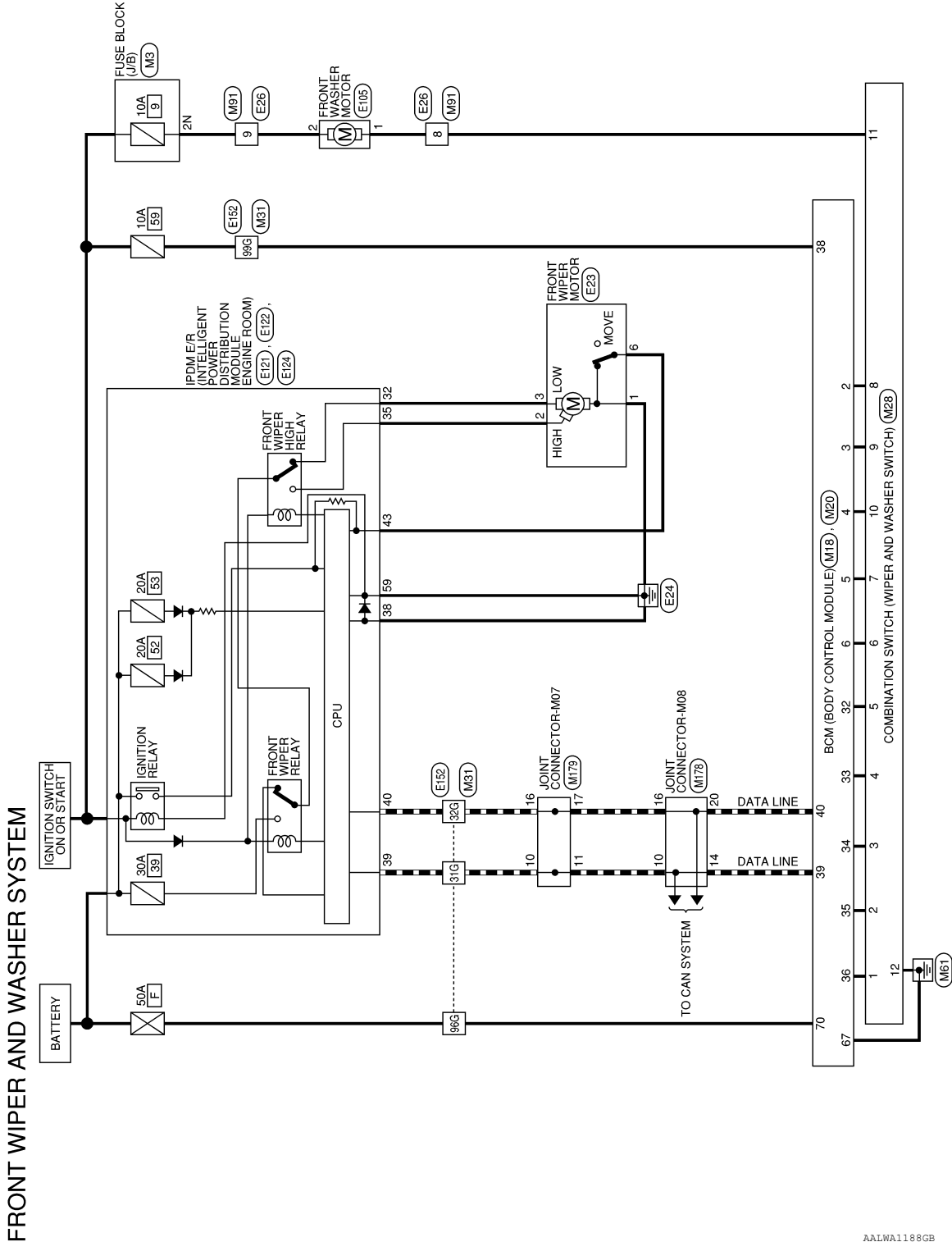

AALWA1188GB

FRONT WIPER AND WASHER SYSTEM

< WIRING DIAGRAM >

FRONT WIPER AND WASHER SYSTEM CONNECTORS

Connector No.	M3
Connector Name	FUSE BLOCK (J/B)
Connector Color	WHITE

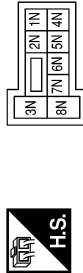

Terminal No.	Color of Wire	Signal Name
2N	W/R	-

Connector No.	M18
Connector Name	BCM (BODY CONTROL MODULE)
Connector Color	WHITE



Terminal No.	Color of Wire	Signal Name
2	SB	INPUT 5
3	G/Y	INPUT 4
4	Y	INPUT 3
5	G/B	INPUT 2
6	V	INPUT 1
32	R/G	OUTPUT 5
33	R/Y	OUTPUT 4
34	L	OUTPUT 3
35	O/B	OUTPUT 2
36	R/W	OUTPUT 1
38	W/L	IGN SW
39	L	CAN-H
40	P	CAN-L

Connector No.	M20
Connector Name	BCM (BODY CONTROL MODULE)
Connector Color	BLACK

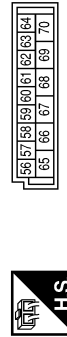

Connector No.	M28
Connector Name	COMBINATION SWITCH (WIPER AND WASHER SWITCH)
Connector Color	WHITE

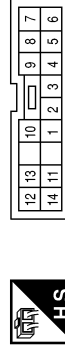

Terminal No.	Color of Wire	Signal Name
1	R/W	-
2	O/B	-
3	L	-
4	R/Y	-
5	R/G	-
6	V	-
7	G/B	-
8	SB	-
9	G/Y	-
10	Y	-
11	V/W	-
12	B	-

Terminal No.	Color of Wire	Signal Name
67	B	GND (POWER)
70	W/B	BAT (F/L)

AALIA3462GB

A
B
C
D
E
F
G
H
I
J
K
L
M
N
O
P

WW

FRONT WIPER AND WASHER SYSTEM

< WIRING DIAGRAM >

Connector No.	M91
Connector Name	WIRE TO WIRE
Connector Color	WHITE

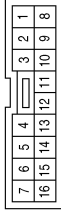

Terminal No.	Color of Wire	Signal Name
8	V/W	-
9	W/R	-

Terminal No.	Color of Wire	Signal Name
31G	L	-
32G	P	-
96G	W/B	-
99G	W/L	-

Connector No.	M31
Connector Name	WIRE TO WIRE
Connector Color	WHITE

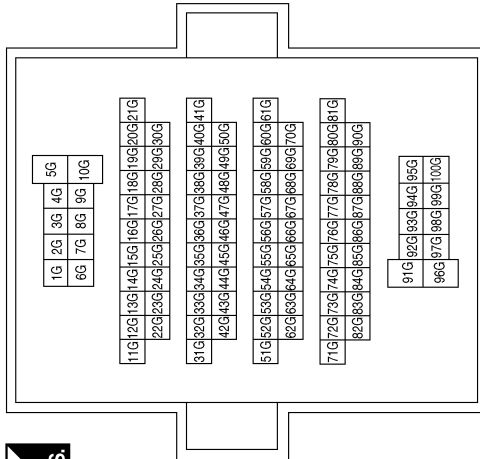
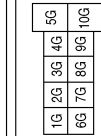

Connector No.	E23
Connector Name	FRONT WIPER MOTOR
Connector Color	GRAY

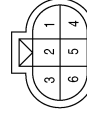

Terminal No.	Color of Wire	Signal Name
1	B	-
2	L/B	-
3	L	-
6	L/Y	-

Connector No.	M179
Connector Name	JOINT CONNECTOR-M07
Connector Color	WHITE

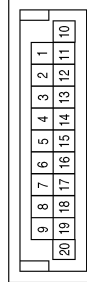

Terminal No.	Color of Wire	Signal Name
10	L	-
11	L	-
16	P	-
17	P	-

Connector No.	M178
Connector Name	JOINT CONNECTOR-M08
Connector Color	WHITE

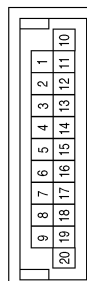

Terminal No.	Color of Wire	Signal Name
10	L	-
14	L	-
16	P	-
20	P	-

ABLIA6447GB

FRONT WIPER AND WASHER SYSTEM

< WIRING DIAGRAM >

Connector No.	E121
Connector Name	IPDM E/R (INTELLIGENT POWER DISTRIBUTION MODULE ENGINE ROOM)
Connector Color	BROWN



29	28	27	26	25		
36	35	34	33	32	31	30

Terminal No.	Color of Wire	Signal Name
32	L	FR WIPER LO
35	L/B	FR WIPER HI

Connector No.	E105
Connector Name	FRONT WASHER MOTOR
Connector Color	BROWN

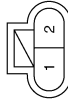

Terminal No.	Color of Wire	Signal Name
1	V/W	-
2	W/R	-

Connector No.	E26
Connector Name	WIRE TO WIRE
Connector Color	WHITE



1	2	3	4	5	6	7		
8	9	10	11	12	13	14	15	16

Terminal No.	Color of Wire	Signal Name
8	V/W	-
9	W/R	-

Connector No.	E124
Connector Name	IPDM E/R (INTELLIGENT POWER DISTRIBUTION MODULE ENGINE ROOM)
Connector Color	BLACK



59	58	57
62	61	60

Terminal No.	Color of Wire	Signal Name
59	B	GND (POWER)

Connector No.	E122
Connector Name	IPDM E/R (INTELLIGENT POWER DISTRIBUTION MODULE ENGINE ROOM)
Connector Color	WHITE



42	41	40	39	38	37
48	47	46	45	44	43

Terminal No.	Color of Wire	Signal Name
38	B	GND (SIGNAL)
39	L	CAN-H
40	P	CAN-L
43	L/Y	AUTO STOP SW

ABLIA2738GB

A
B
C
D
E
F
G
H
I
J
K
L
M
N
O
P

WW

FRONT WIPER AND WASHER SYSTEM

< WIRING DIAGRAM >

Connector No.	E152
Connector Name	WIRE TO WIRE
Connector Color	WHITE

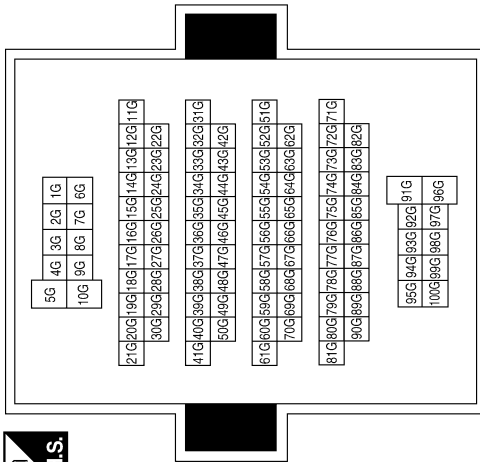

Terminal No.	Color of Wire	Signal Name
31G	L	-
32G	P	-
96G	W/B	-
99G	L/W	-

ABLIA4178GB

WIPER AND WASHER SYSTEM SYMPTOMS

< SYMPTOM DIAGNOSIS >

SYMPTOM DIAGNOSIS

WIPER AND WASHER SYSTEM SYMPTOMS

Symptom Table

INFOID:0000000011559989

CAUTION:

Perform the self-diagnosis with CONSULT before performing the diagnosis by symptom. Perform the diagnosis by DTC if DTC is detected.

Symptom		Probable malfunction location	Inspection item
Front wiper does not operate.	HI only	<ul style="list-style-type: none"> Combination switch (wiper and washer switch) Harness between combination switch (wiper and washer switch) and BCM BCM 	Combination switch (wiper and washer switch) Refer to BCS-53, "Symptom Table" .
		<ul style="list-style-type: none"> IPDM E/R Harness between IPDM E/R and front wiper motor Front wiper motor 	Front wiper motor (HI) circuit Refer to WW-17, "Component Function Check" .
		Front wiper request signal <ul style="list-style-type: none"> BCM IPDM E/R 	IPDM E/R DATA MONITOR "FR WIP REQ"
	LO and INT	<ul style="list-style-type: none"> Combination switch (wiper and washer switch) Harness between combination switch (wiper and washer switch) and BCM BCM 	Combination switch (wiper and washer switch) Refer to BCS-53, "Symptom Table" .
		<ul style="list-style-type: none"> IPDM E/R Harness between IPDM E/R and front wiper motor Front wiper motor 	Front wiper motor (LO) circuit Refer to WW-15, "Component Function Check" .
		Front wiper request signal <ul style="list-style-type: none"> BCM IPDM E/R 	IPDM E/R DATA MONITOR "FR WIP REQ"
	INT only	<ul style="list-style-type: none"> Combination switch (wiper and washer switch) Harness between combination switch (wiper and washer switch) and BCM BCM 	Combination switch (wiper and washer switch) Refer to BCS-53, "Symptom Table" .
		Front wiper request signal <ul style="list-style-type: none"> BCM IPDM E/R 	IPDM E/R DATA MONITOR "FR WIP REQ"
	HI, LO, and INT	SYMPTOM DIAGNOSIS "FRONT WIPER DOES NOT OPERATE" Refer to WW-50, "Diagnosis Procedure" .	

A
B
C
D
E
F
G
H
I
J
K
M
N
O
P

WW

WIPER AND WASHER SYSTEM SYMPTOMS

< SYMPTOM DIAGNOSIS >

Symptom		Probable malfunction location	Inspection item
Front wiper does not stop.	HI only	<ul style="list-style-type: none"> Combination switch (wiper and washer switch) BCM 	Combination switch (wiper and washer switch) Refer to BCS-53. "Symptom Table" .
		Front wiper request signal	IPDM E/R DATA MONITOR "FR WIP REQ"
		<ul style="list-style-type: none"> BCM IPDM E/R 	
	LO only	IPDM E/R	—
		<ul style="list-style-type: none"> Combination switch (wiper and washer switch) BCM 	Combination switch (wiper and washer switch) Refer to BCS-53. "Symptom Table" .
		Front wiper request signal	IPDM E/R DATA MONITOR "FR WIP REQ"
	<ul style="list-style-type: none"> BCM IPDM E/R 		
	INT only	IPDM E/R	—
		<ul style="list-style-type: none"> Combination switch (wiper and washer switch) BCM 	Combination switch (wiper and washer switch) Refer to BCS-53. "Symptom Table" .
Front wiper request signal		IPDM E/R DATA MONITOR "FR WIP REQ"	
<ul style="list-style-type: none"> BCM IPDM E/R 			
Front wiper does not operate normally.	Intermittent adjustment cannot be performed.	<ul style="list-style-type: none"> Combination switch (wiper and washer switch) Harness between combination switch (wiper and washer switch) and BCM BCM 	Combination switch (wiper and washer switch) Refer to BCS-53. "Symptom Table" .
		BCM	—
	Intermittent control linked with vehicle speed cannot be performed.	Check the vehicle speed detection wiper setting. Refer to BCS-24. "WIPER : CONSULT Function (BCM - WIPER)" .	
	Wiper is not linked to the washer operation.	<ul style="list-style-type: none"> Combination switch (wiper and washer switch) Harness between combination switch (wiper and washer switch) and BCM BCM 	Combination switch (wiper and washer switch) Refer to BCS-53. "Symptom Table" .
		BCM	—
Does not return to stop position (Repeatedly operates for 10 seconds and then stops for 20 seconds. After that, it stops the operation).	<ul style="list-style-type: none"> IPDM E/R Harness between IPDM E/R and front wiper motor Front wiper motor 	Front wiper auto stop signal circuit Refer to WW-19. "Component Function Check" .	
Washer motor does not operate.	<ul style="list-style-type: none"> Combination switch (wiper and washer switch) Harness between combination switch (wiper and washer switch) and BCM BCM 	Combination switch (wiper and washer switch) Refer to BCS-53. "Symptom Table" .	
	<ul style="list-style-type: none"> Harness between combination switch (wiper and washer switch) and washer motor Washer motor 	Washer motor circuit Refer to WW-23. "Diagnosis Procedure" .	

NORMAL OPERATING CONDITION

< SYMPTOM DIAGNOSIS >

NORMAL OPERATING CONDITION

Description

INFOID:0000000011559990

FRONT WIPER MOTOR PROTECTION FUNCTION

- IPDM E/R may stop the front wiper to protect the front wiper motor if any obstruction (operation resistance) such as a large amount of snow is detected during the front wiper operation.
- At that time turn OFF the front wiper and remove the foreign object. Then wait for approximately 20 seconds or more and reactivate the front wiper. The wiper will operate normally.

A

B

C

D

E

F

G

H

I

J

K

WW

M

N

O

P

FRONT WIPER DOES NOT OPERATE

< SYMPTOM DIAGNOSIS >

FRONT WIPER DOES NOT OPERATE

Description

INFOID:000000011559991

The front wiper does not operate under any operation conditions.

Diagnosis Procedure

INFOID:000000011559992

Regarding Wiring Diagram information, refer to [WW-42, "Wiring Diagram"](#).

1. CHECK WIPER RELAY OPERATION

⊗ IPDM E/R AUTO ACTIVE TEST

1. Start IPDM E/R auto active test. Refer to [PCS-11, "Diagnosis Description"](#).
2. Check that the front wiper operates at the LO/HI operation.

Ⓟ WITH CONSULT ACTIVE TEST

1. Select "FRONT WIPER" of IPDM E/R active test item.
2. While operating the test item, check front wiper operation.

LO : Front wiper LO operation
HI : Front wiper HI operation
OFF : Stop the front wiper.

Is front wiper operation normal?

- YES >> GO TO 5.
NO >> GO TO 2.

2. CHECK FRONT WIPER MOTOR FUSE

1. Turn the ignition switch OFF.
2. Check that the following fuse is not blown.

Unit	Location	Fuse No.	Capacity
Front wiper motor	IPDM E/R	39	30 A

Is the fuse blown?

- YES >> Replace the fuse after repairing the affected circuit.
NO >> GO TO 3.

3. CHECK FRONT WIPER MOTOR GROUND OPEN CIRCUIT

1. Disconnect front wiper motor.
2. Check continuity between front wiper motor harness connector and ground.

Front wiper motor		Ground	Continuity
Connector	Terminal		
E23	1		Yes

Does continuity exist?

- YES >> GO TO 4.
NO >> Repair or replace harness.

4. CHECK FRONT WIPER MOTOR OUTPUT VOLTAGE

Ⓟ WITH CONSULT ACTIVE TEST

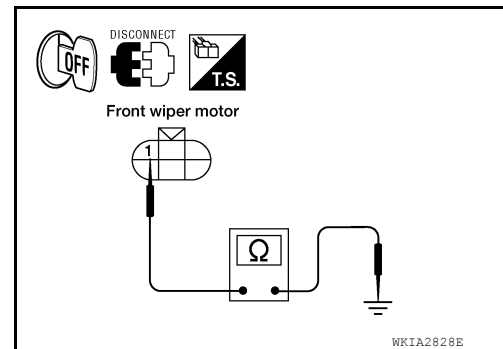

FRONT WIPER DOES NOT OPERATE

< SYMPTOM DIAGNOSIS >

1. Turn the ignition switch ON.
2. Select "FRONT WIPER" of IPDM E/R active test item.
3. With operating the test item, check voltage between IPDM E/R harness connector and ground.

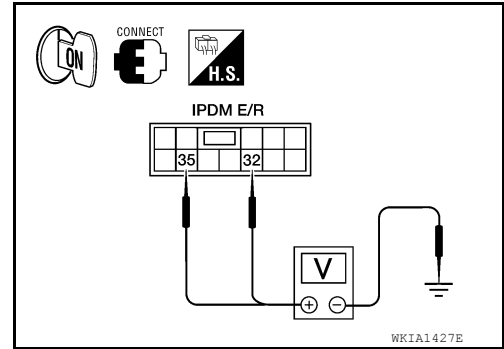

Terminals		Test item	Voltage (Approx.)
(+)	(-)		
IPDM E/R		FRONT WIPER	Battery voltage
Connector	Terminal		
E121	32	LO	0 V
		HI	Battery voltage
	35	OFF	0 V

Is the measurement value normal?

- YES >> Replace front wiper motor. Refer to [WW-54, "Wiper Motor and Linkage"](#).
 NO >> Replace IPDM E/R. Refer to [PCS-28, "Removal and Installation of IPDM E/R"](#).

5. CHECK FRONT WIPER REQUEST SIGNAL INPUT

Ⓜ WITH CONSULT DATA MONITOR

1. Select "FR WIP REQ" of IPDM E/R data monitor item.
2. Switch the front wiper switch to HI and LO.
3. With operating the front wiper switch, check the status of "FR WIP REQ".

Monitor item	Condition	Monitor status	
FR WIP REQ	Front wiper switch HI	HI	ON
		STOP	OFF
	Front wiper switch LO	LOW	ON
		STOP	OFF

Is the status of item normal?

- YES >> Replace IPDM E/R. Refer to [PCS-28, "Removal and Installation of IPDM E/R"](#).
 NO >> GO TO 6.

6. CHECK COMBINATION SWITCH (WIPER AND WASHER SWITCH)

1. Perform the inspection of the combination switch (wiper and washer switch). Refer to [BCS-53, "Symptom Table"](#).

Is combination switch (wiper and washer switch) normal?

- YES >> Replace BCM. Refer to [BCS-56, "Removal and Installation"](#).
 NO >> Repair or replace the applicable parts.

A
B
C
D
E
F
G
H
I
J
K
M
N
O
P

WW

PRECAUTION

< PRECAUTION >

PRECAUTION

PRECAUTION

Precaution for Supplemental Restraint System (SRS) "AIR BAG" and "SEAT BELT PRE-TENSIONER"

INFOID:000000011559993

The Supplemental Restraint System such as "AIR BAG" and "SEAT BELT PRE-TENSIONER", used along with a front seat belt, helps to reduce the risk or severity of injury to the driver and front passenger for certain types of collision. This system includes seat belt switch inputs and dual stage front air bag modules. The SRS system uses the seat belt switches to determine the front air bag deployment, and may only deploy one front air bag, depending on the severity of a collision and whether the front occupants are belted or unbelted. Information necessary to service the system safely is included in the SR and SB section of this Service Manual.

WARNING:

- To avoid rendering the SRS inoperative, which could increase the risk of personal injury or death in the event of a collision which would result in air bag inflation, all maintenance must be performed by an authorized NISSAN/INFINITI dealer.
- Improper maintenance, including incorrect removal and installation of the SRS, can lead to personal injury caused by unintentional activation of the system. For removal of Spiral Cable and Air Bag Module, see the SR section.
- Do not use electrical test equipment on any circuit related to the SRS unless instructed to in this Service Manual. SRS wiring harnesses can be identified by yellow and/or orange harnesses or harness connectors.

PRECAUTIONS WHEN USING POWER TOOLS (AIR OR ELECTRIC) AND HAMMERS

WARNING:

- When working near the Airbag Diagnosis Sensor Unit or other Airbag System sensors with the Ignition ON or engine running, DO NOT use air or electric power tools or strike near the sensor(s) with a hammer. Heavy vibration could activate the sensor(s) and deploy the air bag(s), possibly causing serious injury.
- When using air or electric power tools or hammers, always switch the Ignition OFF, disconnect the battery and wait at least three minutes before performing any service.

FRONT WIPER ARM

< REMOVAL AND INSTALLATION >

REMOVAL AND INSTALLATION

FRONT WIPER ARM

Front Wiper Arms

INFOID:0000000011559994

REMOVAL AND INSTALLATION

Removal

1. Remove wiper arm covers and wiper arm nuts.
2. Remove front RH wiper arm and front LH wiper arm.
3. Remove front RH blade assembly and front LH blade assembly.

Installation

1. Operate wiper motor one full cycle, then turn "OFF" (Auto Stop).
2. Clean up the pivot area as shown. This will reduce possibility of wiper arm looseness.

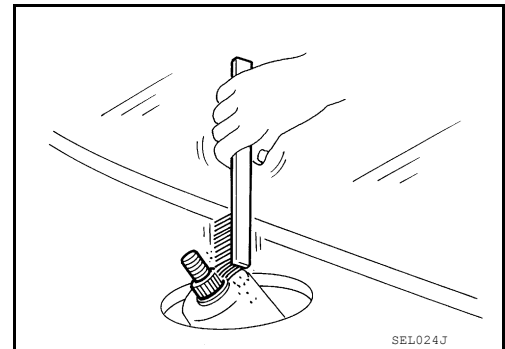

3. Install front RH blade assembly and front LH blade assembly on wiper arms.
4. Install front RH wiper arm and front LH wiper arm.
5. Tighten wiper arm nuts to specified torque, and install wiper arm covers. Refer to [WW-54. "Wiper Motor and Linkage"](#).
6. Ensure that wiper blades stop within proper clearance. See Front Wiper Arm Adjustment.

FRONT WIPER ARM ADJUSTMENT

1. Operate windshield washer and wiper motor one full cycle, then turn "OFF" (Auto Stop).
2. Lift the wiper blade up and then rest it onto glass surface, check the blade clearance "L1" and "L2".

Clearance (A)	: 41 mm (1.614 in)
Clearance (B)	: 41 mm (1.614 in)
Clearance (C)	: 25.5 mm (1.004 in)
Clearance (D)	: 50 mm (1.969 in)

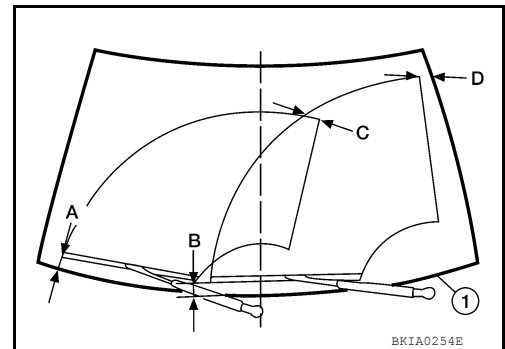

3. Remove wiper arm covers and wiper arm nuts.
4. Adjust front wiper arms on wiper motor pivot shafts to obtain above specified blade clearances.
5. Tighten wiper arm nuts to specified torque, and install wiper arm covers. Refer to [WW-54. "Wiper Motor and Linkage"](#).

WASHER TANK

< REMOVAL AND INSTALLATION >

WASHER TANK

Washer Fluid Reservoir

INFOID:000000011559996

REMOVAL AND INSTALLATION

Removal

1. Remove side washer fluid reservoir screw (2).
 - Front and rear washer motor (1).

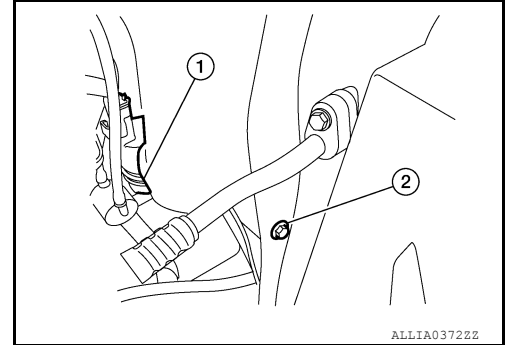

2. Remove front washer motor connector.
3. Remove washer fluid level sensor connector.

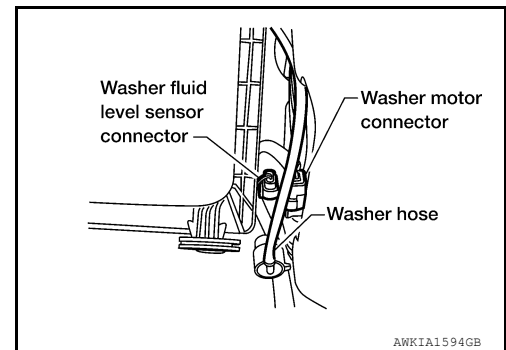

4. Disconnect front hoses.
5. Remove front washer fluid reservoir screw (2).
6. Remove washer fluid reservoir (1) from the vehicle.

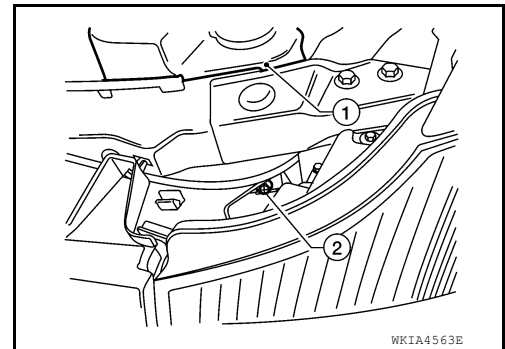

Installation

Installation is in the reverse order of removal.

CAUTION:

After installation, add washer fluid up to the upper level of the washer fluid reservoir inlet and check for leaks.

A
B
C
D
E
F
G
H
I
J
K
WW
M
N
O
P

FRONT WASHER NOZZLE AND TUBE

< REMOVAL AND INSTALLATION >

FRONT WASHER NOZZLE AND TUBE

Washer Tube Layout

INFOID:00000001155997

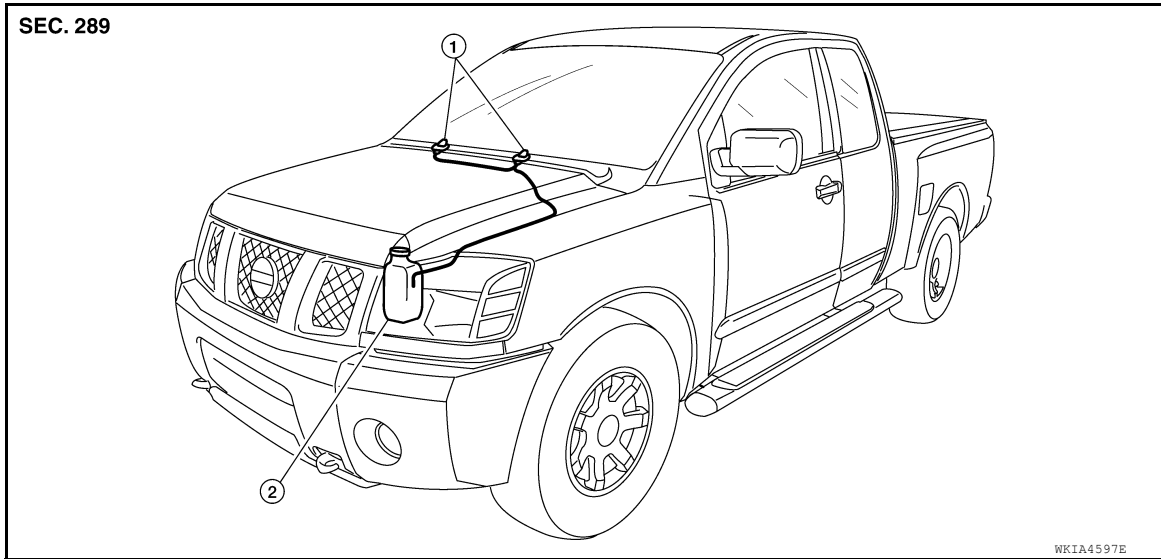

1. Washer nozzles
2. Washer fluid reservoir

Washer Nozzle Adjustment

INFOID:00000001155998

- This vehicle is equipped with non-adjustable washer nozzles.
- If not satisfied with washer fluid spray coverage, confirm that the washer nozzle is installed correctly.
- If the washer nozzle is installed correctly, and the washer fluid spray coverage is not satisfactory, replace washer nozzle.

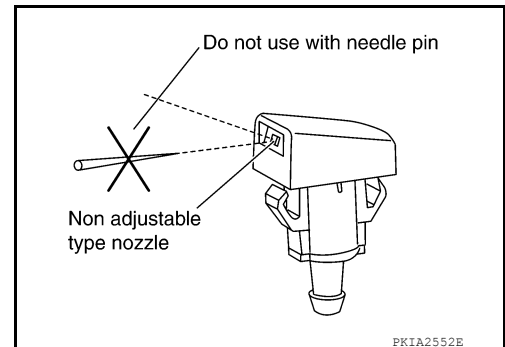

FRONT WIPER AND WASHER SWITCH

< REMOVAL AND INSTALLATION >

FRONT WIPER AND WASHER SWITCH

Wiper and Washer Switch

INFOID:000000011559999

REMOVAL AND INSTALLATION

Removal

1. Remove the instrument lower panel LH. Refer to [IP-10, "Exploded View"](#)
2. Remove steering column covers.
3. Remove wiper washer switch connector.
4. Pinch tabs at wiper and washer switch base and slide switch away from steering column to remove.

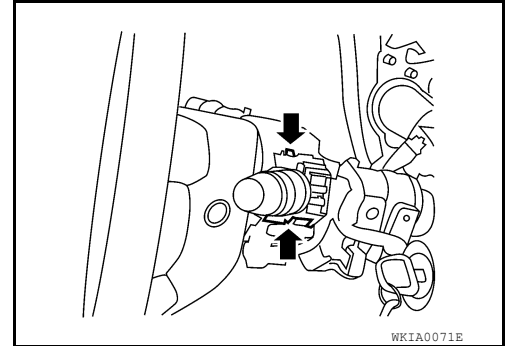

Installation

Installation is in the reverse order of removal.

A
B
C
D
E
F
G
H
I
J
K
L
M
N
O
P

WW

WASHER PUMP

< REMOVAL AND INSTALLATION >

WASHER PUMP

Washer Motor

INFOID:000000011560000

REMOVAL AND INSTALLATION

Removal

1. Remove washer fluid reservoir. Refer to [WW-55. "Washer Fluid Reservoir"](#).
2. Disconnect washer hose from washer motor.
3. Disconnect harness connector from washer motor.
4. Remove washer motor (1) in the direction of the arrow as shown, from washer fluid reservoir (2).

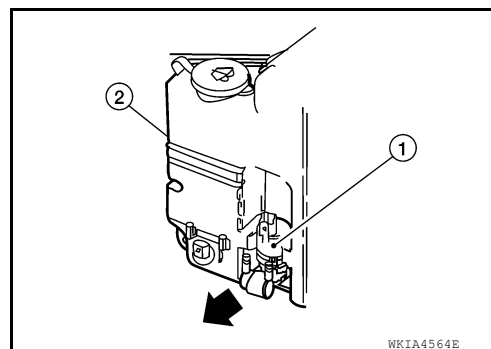

Installation

Installation is in the reverse order of removal.

WASHER LEVEL SWITCH

< REMOVAL AND INSTALLATION >

WASHER LEVEL SWITCH

Removal and Installation

INFOID:000000011875192

REMOVAL AND INSTALLATION

Removal

1. Remove washer fluid reservoir. Refer to [WW-55, "Washer Fluid Reservoir"](#)
2. Remove washer hose from washer motor.
3. Remove harness connectors from washer motor and washer level sensor.
4. Remove washer level sensor.

Installation

Installation is in the reverse order of removal.

A

B

C

D

E

F

G

H

I

J

K

WW

M

N

O

P

SERVICE DATA AND SPECIFICATIONS (SDS)

< SERVICE DATA AND SPECIFICATIONS (SDS)

SERVICE DATA AND SPECIFICATIONS (SDS)

SERVICE DATA AND SPECIFICATIONS (SDS)

Specifications

INFOID:0000000011560001

WINDSHIELD WASHER FLUID

Windshield washer fluid capacity	4.5 ℓ (4 3/4 US qt, 4 Imp qt)
Windshield washer fluid specification	Refer to MA-15. "FOR NORTH AMERICA : Fluids and Lubricants" (United States and Canada), MA-17. "FOR MEXICO : Fluids and Lubricants" (Mexico).