

SECTION **DLK**
DOOR & LOCK

A
B
C

CONTENTS

D
E

PRECAUTION	6	Integrated Homelink Transmitter	16	F
PRECAUTIONS	6	SYSTEM (POWER DOOR LOCK SYSTEM)	17	G
Precaution for Supplemental Restraint System (SRS) "AIR BAG" and "SEAT BELT PRE-TENSIONER"	6	System Description	17	
Precaution for Servicing Doors and Locks	6	SYSTEM (INTELLIGENT KEY SYSTEM)	19	H
PREPARATION	7	INTELLIGENT KEY SYSTEM	19	
PREPARATION	7	INTELLIGENT KEY SYSTEM : System Description	19	I
Special Service Tool	7	DOOR LOCK FUNCTION	20	J
Commercial Service Tool	8	DOOR LOCK FUNCTION : System Description	20	
SYSTEM DESCRIPTION	9	REMOTE KEYLESS ENTRY FUNCTION	22	
COMPONENT PARTS	9	REMOTE KEYLESS ENTRY FUNCTION : System Description	22	
POWER DOOR LOCK SYSTEM	9	WARNING FUNCTION	24	
POWER DOOR LOCK SYSTEM : Component Parts Location	9	WARNING FUNCTION : System Description	24	DLK
INTELLIGENT KEY SYSTEM	10	KEY REMINDER FUNCTION	27	L
INTELLIGENT KEY SYSTEM : Component Parts Location	11	KEY REMINDER FUNCTION : System Description	27	
INTEGRATED HOMELINK TRANSMITTER	13	REMOTE ENGINE START FUNCTION	28	M
INTEGRATED HOMELINK TRANSMITTER : Component Parts Location	13	REMOTE ENGINE START FUNCTION : System Description	28	
Door Lock and Unlock Switch (Driver Side)	13	SYSTEM (INTEGRATED HOMELINK TRANSMITTER)	31	N
Door Lock and Unlock Switch (Passenger Side)	13	System Description	31	
Remote Keyless Entry Receiver	13	DIAGNOSIS SYSTEM (BCM)	32	O
Inside Key Antenna (Instrument Center)	14	COMMON ITEM	32	P
Inside Key Antenna (Console)	14	COMMON ITEM : CONSULT Function (BCM - COMMON ITEM)	32	
Outside Key Antenna (LH)	14	DOOR LOCK	33	
Outside Key Antenna (RH)	14	DOOR LOCK : CONSULT Function (BCM - DOOR LOCK)	33	
Intelligent Key Warning Buzzer	15	INTELLIGENT KEY	34	
Front Door Request Switch (LH)	15			
Front Door Request Switch (RH)	15			
Front Door Switch	15			
Rear Door Switch	16			
Front Door Lock Assembly (LH)	16			

INTELLIGENT KEY : CONSULT Function (BCM - INTELLIGENT KEY)	34	BCM	89
		BCM : Diagnosis Procedure	89
ECU DIAGNOSIS INFORMATION	38	B2626 OUTSIDE ANTENNA	90
BCM	38	DTC Description	90
List of ECU Reference	38	Diagnosis Procedure	90
WIRING DIAGRAM	39	B2627 OUTSIDE ANTENNA	93
INTELLIGENT KEY SYSTEM	39	DTC Description	93
Wiring Diagram	39	Diagnosis Procedure	93
HOMELINK UNIVERSAL TRANSCEIVER	54	DOOR SWITCH	96
Wiring Diagram	54	Component Function Check	96
POWER DOOR LOCK SYSTEM	56	Diagnosis Procedure	96
Wiring Diagram	56	Component Inspection	97
BASIC INSPECTION	69	DOOR LOCK AND UNLOCK SWITCH	98
DIAGNOSIS AND REPAIR WORK FLOW	69	DRIVER SIDE	98
Work Flow	69	DRIVER SIDE : Component Function Check	98
ADDITIONAL SERVICE WHEN REPLACING		DRIVER SIDE : Diagnosis Procedure	98
BCM	72	PASSENGER SIDE	98
Description	72	PASSENGER SIDE :	
Work Procedure	72	Component Function Check	98
DTC/CIRCUIT DIAGNOSIS	73	PASSENGER SIDE : Diagnosis Procedure	98
U1000 CAN COMM CIRCUIT	73	DOOR LOCK ACTUATOR	100
DTC Description	73	DRIVER SIDE	100
Diagnosis Procedure	73	DRIVER SIDE : Component Function Check	100
U1010 CONTROL UNIT (CAN)	74	DRIVER SIDE : Diagnosis Procedure	100
DTC Description	74	PASSENGER SIDE	101
Diagnosis Procedure	74	PASSENGER SIDE :	
B2621 INSIDE ANTENNA	75	Component Function Check	101
DTC Description	75	PASSENGER SIDE : Diagnosis Procedure	101
Diagnosis Procedure	75	REAR LH	102
B2622 INSIDE ANTENNA	78	REAR LH : Component Function Check	102
DTC Description	78	REAR LH : Diagnosis Procedure	102
Diagnosis Procedure	78	REAR RH	103
B26FD SHIFT LOCK SOLENOID	81	REAR RH : Component Function Check	103
DTC Description	81	REAR RH : Diagnosis Procedure	104
Diagnosis Procedure	81	UNLOCK SENSOR	105
B26FE HOOD SWITCH	83	Component Function Check	105
DTC Description	83	Diagnosis Procedure	105
Diagnosis Procedure	83	Component Inspection	106
Component Inspection	84	DOOR KEY CYLINDER SWITCH	107
B26FF REMOTE KEYLESS ENTRY RECEIV- ER	86	Component Function Check	107
DTC Description	86	Diagnosis Procedure	107
Diagnosis Procedure	86	Component Inspection	108
POWER SUPPLY AND GROUND CIRCUIT	89	REMOTE KEYLESS ENTRY RECEIVER	109
		Component Function Check	109
		Diagnosis Procedure	109
		DOOR REQUEST SWITCH	111
		Component Function Check	111
		Diagnosis Procedure	111

Component Inspection	112	DOOR DOES NOT LOCK/UNLOCK WITH INTELLIGENT KEY	131	A
INTELLIGENT KEY WARNING BUZZER	113	Description	131	
Component Function Check	113	Diagnosis Procedure	131	B
Diagnosis Procedure	113	DOOR DOES NOT LOCK/UNLOCK WITH DOOR REQUEST SWITCH AND INTELLIGENT KEY	132	C
Component Inspection	113	Description	132	
INTELLIGENT KEY	115	Diagnosis Procedure	132	D
Component Function Check	115	INTELLIGENT KEY BUTTON OPERATION HAS POOR RANGE (ALL KEYS)	133	E
Diagnosis Procedure	115	Description	133	
METER BUZZER CIRCUIT	116	Diagnosis Procedure	133	F
Description	116	DOOR DOES NOT LOCK/UNLOCK WITH INTELLIGENT KEY (ONE KEY)	135	G
Component Function Check	116	Description	135	
Diagnosis Procedure	116	Diagnosis Procedure	135	H
KEY WARNING LAMP	117	DOOR DOES NOT LOCK/UNLOCK AND ENGINE DOES NOT START (ONE I-KEY/REQ SW/PUSH SW)	136	I
Component Function Check	117	Description	136	
Diagnosis Procedure	117	Diagnosis Procedure	136	J
HAZARD FUNCTION	118	INTELLIGENT KEY SYSTEM ALL FUNCTIONS CANNOT OPERATE (ONE KEY)	138	
Component Function Check	118	Description	138	
Diagnosis Procedure	118	Diagnosis Procedure	138	
HOOD SWITCH	119	INTELLIGENT KEY BUTTON OPERATION HAS POOR RANGE (ONE KEY)	140	
Component Function Check	119	Description	140	
Diagnosis Procedure	119	Diagnosis Procedure	140	
Component Inspection	120	REMOVAL AND INSTALLATION	141	
INTEGRATED HOMELINK TRANSMITTER ...	121	HOOD	141	L
Component Function Check	121	Exploded View	141	
Diagnosis Procedure	121	HOOD ASSEMBLY	141	M
SYMPTOM DIAGNOSIS	123	HOOD ASSEMBLY : Removal and Installation	141	
INTELLIGENT KEY SYSTEM SYMPTOMS	123	HOOD ASSEMBLY : Adjustment	142	N
Diagnosis Procedure	123	HOOD HINGE	144	
ALL DOORS DO NOT LOCK/UNLOCK OR TRUNK/BACK DOOR DO NOT OPEN WITH REQUEST SWITCH	124	HOOD HINGE : Removal and Installation	144	O
Description	124	RADIATOR CORE SEAL	144	
Diagnosis Procedure	124	RADIATOR CORE SEAL : Removal and Installation	144	P
DOOR DOES NOT LOCK/UNLOCK AND ENGINE DOES NOT START (REQ SW/PUSH SW) (ALL KEYS)	126	HOOD INSULATOR	144	
Description	126	HOOD INSULATOR : Removal and Installation ...	145	
Diagnosis Procedure	126	HOOD STAY	145	
DOOR DOES NOT LOCK/UNLOCK AND ENGINE DOES NOT START (ALL I-KEY/REQ SW/PUSH SW)	128	HOOD STAY : Removal and Installation	145	
Description	128	HOOD STAY : Disposal	145	
Diagnosis Procedure	128	RADIATOR CORE SUPPORT	147	
INTELLIGENT KEY SYSTEM ALL FUNCTIONS CANNOT OPERATE (ALL KEYS)	129	Exploded View	147	
Description	129			
Diagnosis Procedure	129			

Removal and Installation	147	HOOD LOCK RELEASE CABLE : Removal and Installation	166
FRONT FENDER	149	FRONT DOOR LOCK	167
Exploded View	149	Exploded View	167
Removal and Installation	149	DOOR LOCK	167
FRONT DOOR	151	DOOR LOCK : Removal and Installation	167
Exploded View	151	INSIDE HANDLE	168
DOOR ASSEMBLY	151	INSIDE HANDLE : Removal and Installation	168
DOOR ASSEMBLY : Removal and Installation	151	OUTSIDE HANDLE	169
DOOR ASSEMBLY : Adjustment	152	OUTSIDE HANDLE : Removal and Installation ...	169
DOOR HINGE	154	DOOR STRIKER	171
DOOR HINGE : Removal and Installation	154	DOOR STRIKER : Removal and Installation	171
DOOR CHECK LINK	154	DOOR STRIKER : Adjustment	171
DOOR CHECK LINK : Removal and Installation ..	154	REAR DOOR LOCK	172
DOOR WEATHER-STRIP	155	Exploded View	172
DOOR WEATHER-STRIP : Removal and Installation	155	DOOR LOCK	172
REAR DOOR	156	DOOR LOCK : Removal and Installation	172
Exploded View	156	INSIDE HANDLE	173
DOOR ASSEMBLY	156	INSIDE HANDLE : Removal and Installation	173
DOOR ASSEMBLY : Removal and Installation	156	OUTSIDE HANDLE	173
DOOR ASSEMBLY : Adjustment	157	OUTSIDE HANDLE : Removal and Installation ...	173
DOOR HINGE	159	DOOR STRIKER	175
DOOR HINGE : Removal and Installation	159	DOOR STRIKER : Removal and Installation	175
DOOR CHECK LINK	159	DOOR STRIKER : Adjustment	175
DOOR CHECK LINK : Removal and Installation ..	159	TAILGATE LOCK	177
DOOR WEATHER-STRIP	160	Exploded View	177
DOOR WEATHER-STRIP : Removal and Installation	160	TAILGATE LOCK	177
TAILGATE	161	TAILGATE LOCK : Removal and Installation	177
Exploded View	161	TAILGATE LOCK : Inspection	178
TAILGATE ASSEMBLY	161	TAILGATE HANDLE	178
TAILGATE ASSEMBLY : Removal and Installation	161	TAILGATE HANDLE : Removal and Installation ..	178
TAILGATE STRIKER	162	FUEL FILLER LID	180
TAILGATE STRIKER : Removal and Installation ..	162	Exploded View	180
TAILGATE HINGE	163	FUEL FILLER LID	180
TAILGATE HINGE : Removal and Installation	163	FUEL FILLER LID : Removal and Installation	180
TAILGATE STAY	163	KEY CYLINDER	182
TAILGATE STAY : Removal and Installation	164	GLOVE BOX LID KEY CYLINDER	182
TAILGATE STAY : Disposal	164	GLOVE BOX LID KEY CYLINDER : Removal and Installation	182
HOOD LOCK	165	DOOR SWITCH	183
Exploded View	165	Removal and Installation	183
HOOD LOCK	165	INSIDE KEY ANTENNA	184
HOOD LOCK : Removal and Installation	165	INSTRUMENT CENTER	184
HOOD LOCK : Inspection	166	INSTRUMENT CENTER : Removal and Installation	184
HOOD LOCK RELEASE CABLE	166		

CONSOLE	184	PASSENGER SIDE	186	
CONSOLE : Removal and Installation	184	PASSENGER SIDE : Removal and Installation ...	186	A
OUTSIDE KEY ANTENNA	185	INTELLIGENT KEY WARNING BUZZER	187	
OUTSIDE HANDLE	185	Removal and Installation	187	B
OUTSIDE HANDLE : Removal and Installation ...	185	REMOTE KEYLESS ENTRY RECEIVER	188	
DOOR REQUEST SWITCH	186	Removal and Installation	188	C
DRIVER SIDE	186	INTELLIGENT KEY BATTERY	189	
DRIVER SIDE : Removal and Installation	186	Removal and Installation	189	D

A
B
C
D
E
F
G
H
I
J
L
M
N
O
P

DLK

PRECAUTIONS

< PRECAUTION >

PRECAUTION

PRECAUTIONS

Precaution for Supplemental Restraint System (SRS) "AIR BAG" and "SEAT BELT PRE-TENSIONER"

INFOID:000000013496664

The Supplemental Restraint System such as "AIR BAG" and "SEAT BELT PRE-TENSIONER", used along with a front seat belt, helps to reduce the risk or severity of injury to the driver and front passenger for certain types of collision. Information necessary to service the system safely is included in the SR and SB section of this Service Manual.

WARNING:

- To avoid rendering the SRS inoperative, which could increase the risk of personal injury or death in the event of a collision which would result in air bag inflation, it is recommended that all maintenance and repair be performed by an authorized NISSAN/INFINITI dealer.
- Improper repair, including incorrect removal and installation of the SRS, can lead to personal injury caused by unintentional activation of the system. For removal of Spiral Cable and Air Bag Module, see the SR section.
- Do not use electrical test equipment on any circuit related to the SRS unless instructed to in this Service Manual. SRS wiring harnesses can be identified by yellow and/or orange harnesses or harness connectors.

PRECAUTIONS WHEN USING POWER TOOLS (AIR OR ELECTRIC) AND HAMMERS

WARNING:

- When working near the Air Bag Diagnosis Sensor Unit or other Air Bag System sensors with the Ignition ON or engine running, DO NOT use air or electric power tools or strike near the sensor(s) with a hammer. Heavy vibration could activate the sensor(s) and deploy the air bag(s), possibly causing serious injury.
- When using air or electric power tools or hammers, always switch the Ignition OFF, disconnect the battery or batteries, and wait at least three minutes before performing any service.

Precaution for Servicing Doors and Locks

INFOID:000000013000226

WARNING:

Radio waves could adversely affect electric medical equipment. Those who use a pacemaker should contact the electric medical equipment manufacturer for the possible influences before use.

- After removing and installing the opening/closing parts, be sure to carry out fitting adjustments to check their operation.
- Check the lubrication level, damage, and wear of each part. If necessary, grease or replace it.
- When removing or disassembling each component, be careful not to damage or deform it. If a component may be subject to interference, be sure to protect it with a shop cloth.
- When removing (disengaging) components with a screwdriver or similar tool, be sure to wrap the component with a shop cloth or vinyl tape to protect it.
- Protect the removed parts with a shop cloth and prevent them from being dropped.
- Replace a deformed or damaged clip.
- If a part is specified as a non-reusable part, always replace it with a new one.
- Be sure to tighten bolts and nuts securely to the specified torque.
- After installation is complete, be sure to check that each part works properly.
- Follow the steps below to clean components:
 - Water soluble dirt:
 - Dip a soft cloth into lukewarm water, wring the water out of the cloth and wipe the dirty area.
 - Then rub with a soft, dry cloth.
 - Oily dirt:
 - Dip a soft cloth into lukewarm water with mild detergent (concentration: within 2 to 3%) and wipe the dirty area.
 - Then dip a cloth into fresh water, wring the water out of the cloth and wipe the detergent off.
 - Then rub with a soft, dry cloth.
 - Do not use organic solvent such as thinner, benzene, alcohol or gasoline.
 - For genuine leather seats, use a genuine leather seat cleaner.

PREPARATION

< PREPARATION >

PREPARATION

PREPARATION

Special Service Tool

INFOID:0000000013000227

The actual shape of the tools may differ from those illustrated here.

Tool number (TechMate No.) Tool name	Description
— (J-39570) Chassis Ear	Locating the noise
— (J-50397) NISSAN Squeak and Rattle Kit	Repairing the cause of noise
— (J-43241) Remote Keyless Entry Tester	Used to test keyfobs
— (J-50190) Signal Tech II	<ul style="list-style-type: none"> • Activate and display TPMS transmitter IDs • Display tire pressure reported by the TPMS transmitter • Read TPMS DTCs • Register TPMS transmitter IDs • Check Intelligent Key relative signal strength • Confirm vehicle Intelligent Key antenna signal strength • Compatible with future sensors • Equipped with a display

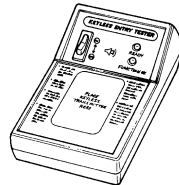
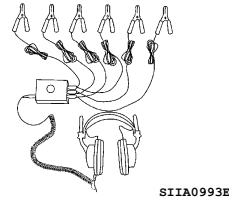

A
B
C
D
E
F
G
H
I
J
DLK
L
M
N
O
P

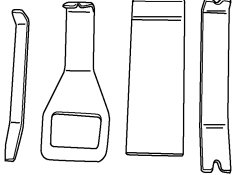

PREPARATION

< PREPARATION >

Tool number (TechMate No.) Tool name	Description
KV48105501 (J-45295-A) Transmitter Activation Tool  ALEIA0183ZZ	<ul style="list-style-type: none"> • Activate TPMS transmitter IDs • Compatible with future sensors • Equipped with a display (KV48105501 only)
— (J-46534) Trim Tool Set  AWJIA0483ZZ	Removing trim components

Commercial Service Tool

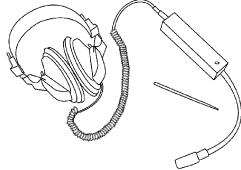
INFOID:000000013000228

(TechMate No.) Tool name	Description
(J-39565) Engine Ear  SIRA0995E	Locating the noise
Power Tool  PIIB1407E	Loosening nuts, screws and bolts

COMPONENT PARTS

< SYSTEM DESCRIPTION >

SYSTEM DESCRIPTION

COMPONENT PARTS

POWER DOOR LOCK SYSTEM

POWER DOOR LOCK SYSTEM : Component Parts Location

INFOID:000000013036933

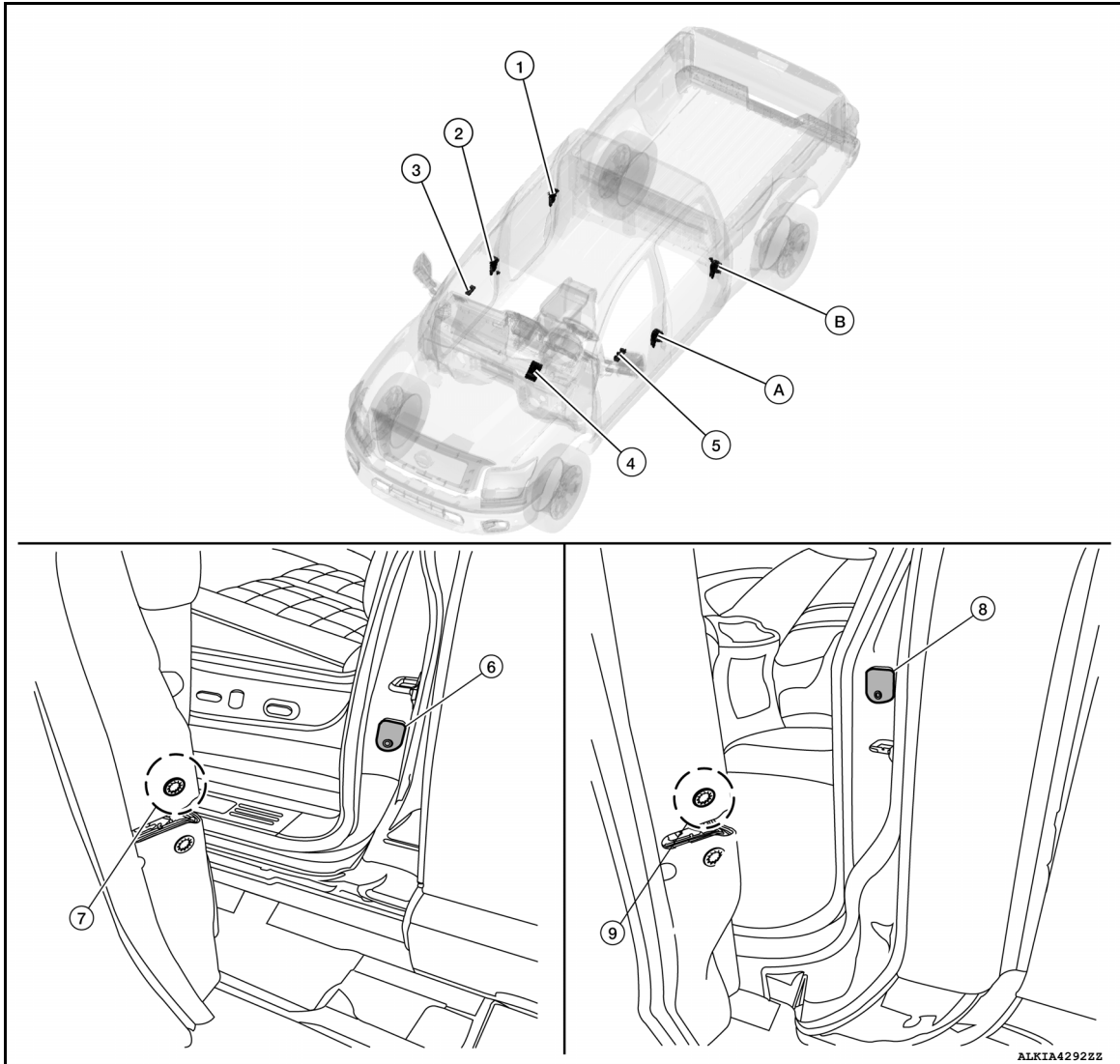

A. View of left front door

B. View of left rear door

No.	Component	Function
1.	Rear door lock actuator RH	Rear door lock actuator locks/unlocks the rear door latch assembly.
2.	Front door lock actuator RH	Front door lock actuator locks/unlocks the front door latch assembly.
3.	Power window and door lock/unlock switch RH	DLK-13. "Door Lock and Unlock Switch (Passenger Side)"
4.	BCM	BCM controls the door lock system. Refer to BCS-5. "BODY CONTROL SYSTEM : Component Parts Location" for detailed installation location.
5.	Main power window and door lock/unlock switch	DLK-13. "Door Lock and Unlock Switch (Driver Side)"
6.	Front door switch LH	DLK-15. "Front Door Switch"

A
B
C
D
E
F
G
H
I
J
K
L
M
N
O
P

DLK

COMPONENT PARTS

< SYSTEM DESCRIPTION >

No.	Component	Function
7.	Front door lock assembly LH	DLK-16. "Front Door Lock Assembly (LH)"
8.	Rear door switch LH	DLK-16. "Rear Door Switch"
9.	Rear door lock actuator LH	Rear door lock actuator locks/unlocks the rear door latch assembly.

INTELLIGENT KEY SYSTEM

COMPONENT PARTS

< SYSTEM DESCRIPTION >

INTELLIGENT KEY SYSTEM : Component Parts Location

INFOID:000000013036934

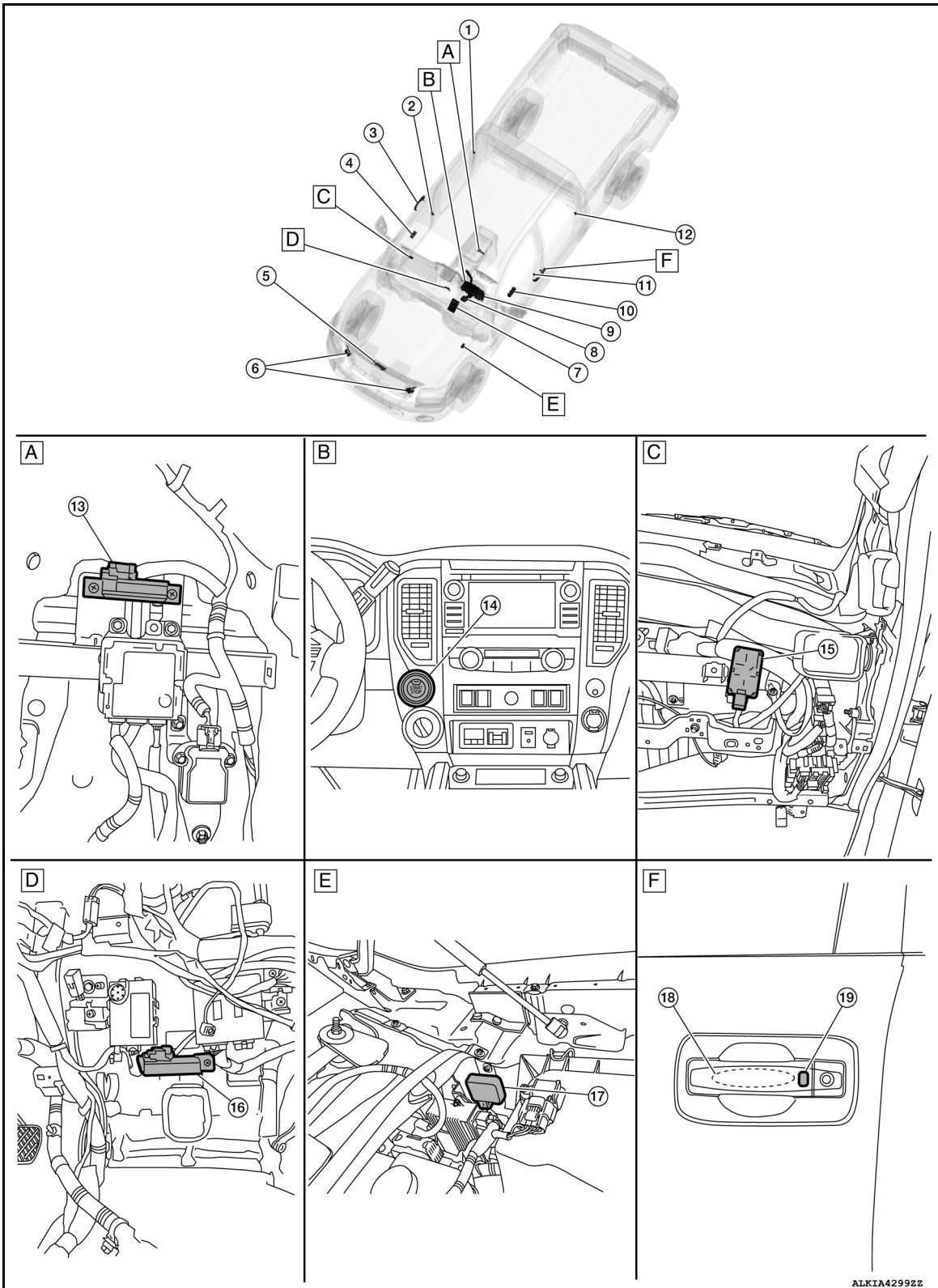

- A. Center console area (view with center console removed)
- D. Center of instrument panel (view with instrument panel assembly removed)

- B. Center of the instrument panel
- E. Engine room left side

- C. Instrument lower panel RH (with instrument panel assembly removed)
- F. Left front outside door handle

A
B
C
D
E
F
G
H
I
J
DLK
L
M
N
O
P

COMPONENT PARTS

< SYSTEM DESCRIPTION >

No.	Component	Function
1.	Rear door switch RH	Door switch detects door open/close condition and then transmits ON/OFF signal to BCM.
2.	Front door switch RH	Door switch detects door open/close condition and then transmits ON/OFF signal to BCM.
3.	Front outside handle assembly RH (door request switch RH) and (outside key antenna RH)	<ul style="list-style-type: none"> • Door request switch transmits door lock/unlock request signal to the BCM. • Outside key antenna (RH) detects whether Intelligent Key is outside the vehicle or not, and then transmits the signal to the BCM.
4.	Power window and door lock/unlock switch RH	Door lock and unlock switch is integrated into the power window switch. Door lock and unlock switch transmits door lock/unlock operation signal to BCM.
5.	Hood switch	Hood switch detects hood open/close condition and then transmits ON/OFF signal to IPDM E/R.
6.	Horns	IPDM E/R energizes the horns when the security system is activated after door lock.
7.	BCM	<p>BCM controls INTELLIGENT KEY SYSTEM (ENGINE START FUNCTION), NISSAN VEHICLE IMMOBILIZER SYSTEM-NATS [NVIS (NATS)] and VEHICLE SECURITY SYSTEM.</p> <p>BCM performs the ID verification between BCM and Intelligent Key when the Intelligent Key is carried into the detection area of inside key antenna and push-button ignition switch is pressed. If the ID verification result is OK, ignition switch operation is available.</p> <p>Then, when the ignition switch is turned ON, BCM performs ID verification between BCM and ECM. If the ID verification result is OK, ECM can start engine. Refer to BCS-5, "BODY CONTROL SYSTEM : Component Parts Location" for detailed installation location.</p>
8.	A/T shift selector	A/T shift selector detects the shift lever status, transmits park position switch signal to the BCM.
9.	Combination meter	<p>Combination meter transmits the vehicle speed signal to BCM via CAN communication.</p> <p>BCM also receives the vehicle speed signal from ABS actuator and electric unit (control unit) via CAN communication. BCM compares both signals to detect the vehicle speed.</p> <p>Security indicator lamp is located on combination meter.</p> <p>Security indicator lamp blinks when ignition switch is in any position other than ON to warn that NISSAN VEHICLE IMMOBILIZER SYSTEM-NATS [NVIS (NATS)] is on board.</p> <p>Refer to MWI-8, "METER SYSTEM : Component Parts Location".</p>
10.	Main power window and door lock/unlock switch	<p>Door lock and unlock switch is integrated into the power window main switch.</p> <p>Door lock and unlock switch transmits door lock/unlock operation signal to BCM.</p> <p>Refer to PWC-7, "Main Power Window and Door Lock/Unlock Switch".</p>
11.	Front door switch LH	Door switch detects door open/close condition and then transmits ON/OFF signal to BCM.
12.	Rear door switch LH	Door switch detects door open/close condition and then transmits ON/OFF signal to BCM.
13.	Inside key antenna (console)	<p>Inside key antenna (console) detects whether Intelligent Key is inside the vehicle or not and then transmits the signal to the BCM.</p> <p>Refer to DLK-14, "Inside Key Antenna (Console)".</p>
14.	Push-button ignition switch	<p>Push-button ignition switch has a push switch inside which detects that push-button ignition switch is pressed and then transmits ON/OFF signal to BCM.</p> <p>BCM changes the ignition switch position with the operation of push-button ignition switch. BCM maintains the ignition switch position status while push-button ignition switch is not operated.</p>
15.	Remote keyless entry receiver	<p>Remote keyless entry receiver receives button operation signal and key ID signal of Intelligent Key and then transmits them to BCM.</p> <p>Refer to DLK-13, "Remote Keyless Entry Receiver".</p>

COMPONENT PARTS

< SYSTEM DESCRIPTION >

No.	Component	Function
16.	Inside key antenna (instrument center)	Inside key antenna (instrument center) detects whether Intelligent Key is inside the vehicle or not and then transmits the signal to the BCM. Refer to DLK-14, "Inside Key Antenna (Instrument Center)" .
17.	Intelligent Key warning buzzer	Intelligent Key warning buzzer warns the user, who is outside the vehicle, of operation confirmation according to Intelligent Key operation and door request switch operation or of an inappropriate operation.
18.	Outside key antenna LH	Outside key antenna (LH) detects whether Intelligent Key is outside the vehicle or not and then transmits the signal to the BCM. Refer to DLK-14, "Outside Key Antenna (LH)" .
19.	Door request switch LH	Door request switch transmits door lock/unlock request signal to the BCM.

INTEGRATED HOMELINK TRANSMITTER

INTEGRATED HOMELINK TRANSMITTER : Component Parts Location

INFOID:0000000013036935

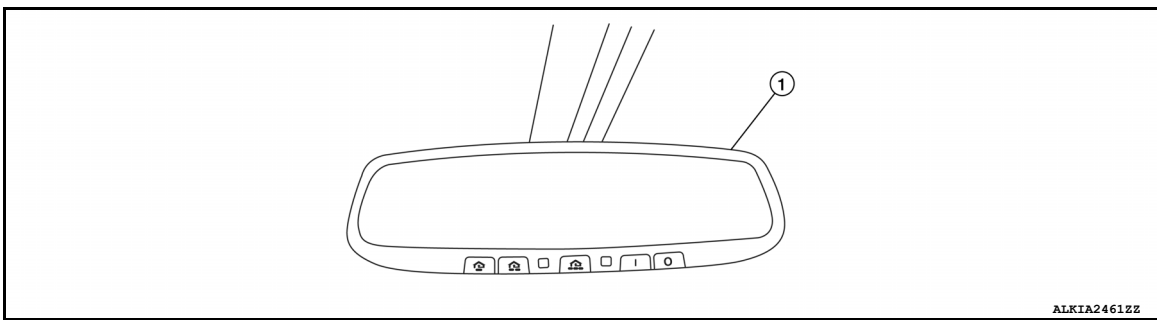

No.	Component	Function
1.	Auto anti-dazzling inside mirror	DLK-16, "Integrated Homelink Transmitter"

Door Lock and Unlock Switch (Driver Side)

INFOID:0000000013036947

- Door lock and unlock switch transmits door lock/unlock signal operation to BCM.
- Door lock and unlock switch is integrated into the power window main switch.

Door Lock and Unlock Switch (Passenger Side)

INFOID:0000000013036948

- Door lock and unlock switch transmits door lock/unlock signal operation to BCM.
- Door lock and unlock switch is integrated into the front power window switch (passenger side).

Remote Keyless Entry Receiver

INFOID:0000000013036949

- Remote keyless entry receiver receives button operation signal and key ID signal of Intelligent Key and then transmits them to BCM.
- Remote keyless entry receiver is installed behind the glove box.

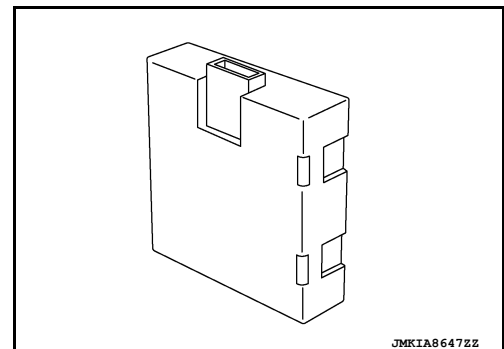

A
B
C
D
E
F
G
H
I
J
L
M
N
O
P

DLK

COMPONENT PARTS

< SYSTEM DESCRIPTION >

Inside Key Antenna (Instrument Center)

INFOID:000000013036950

- Inside key antenna (instrument center) detects that Intelligent Key is within the inside detection area and then transmits detection status to BCM.

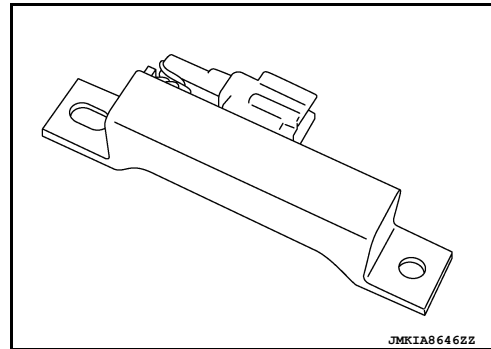

Inside Key Antenna (Console)

INFOID:000000013036951

- Inside key antenna (console) detects that Intelligent Key is within the inside detection area and then transmits detection status to BCM.

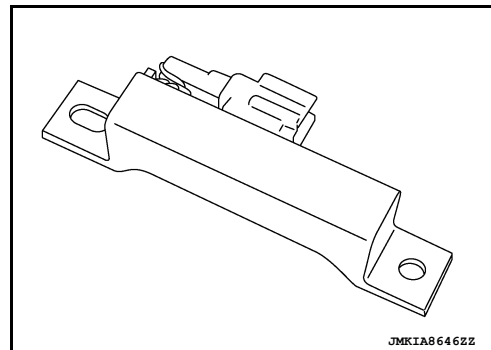

Outside Key Antenna (LH)

INFOID:000000013036953

- Outside key antenna (LH) detects that Intelligent Key is within the outside detection area and then transmits detection status to BCM. Request signal is transmitted simultaneously to Intelligent Key.
- Outside key antenna (LH) is installed in driver side outside handle.

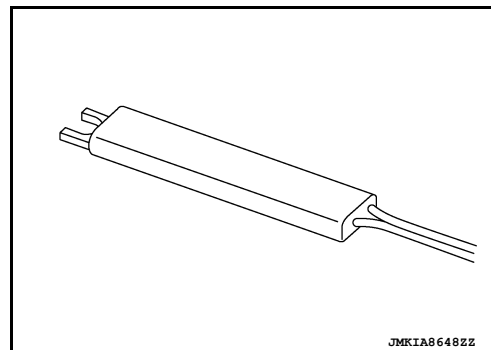

Outside Key Antenna (RH)

INFOID:000000013036954

- Outside key antenna (RH) detects that Intelligent Key is within the outside detection area and then transmits detection status to BCM. Request signal is transmitted simultaneously to Intelligent Key.
- Outside key antenna (RH) is installed in passenger side outside handle.

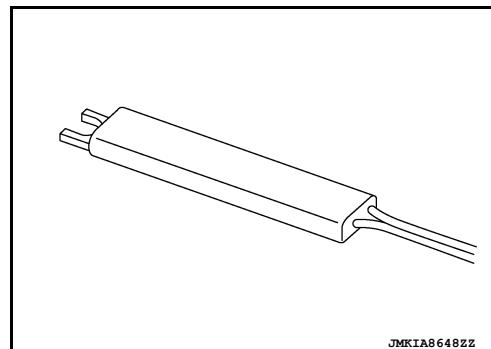

COMPONENT PARTS

< SYSTEM DESCRIPTION >

Intelligent Key Warning Buzzer

INFOID:000000013036955

- Intelligent Key warning buzzer warns the user, who is outside the vehicle, of operation confirmation according to Intelligent Key operation and door request switch operation or of an inappropriate operation.
- Intelligent Key warning buzzer is installed just behind the air cleaner housing.

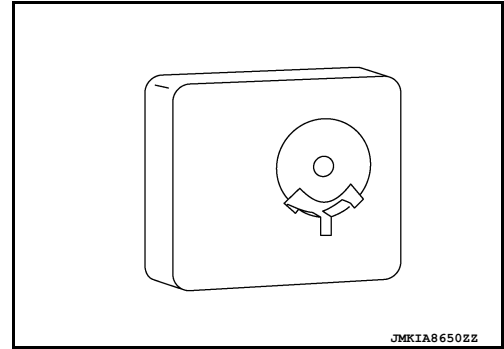

Front Door Request Switch (LH)

INFOID:000000013036956

- Front door request switch (LH) transmits door request switch signal to BCM.
- Front door request switch (LH) (1) is integrated into driver side outside handle.

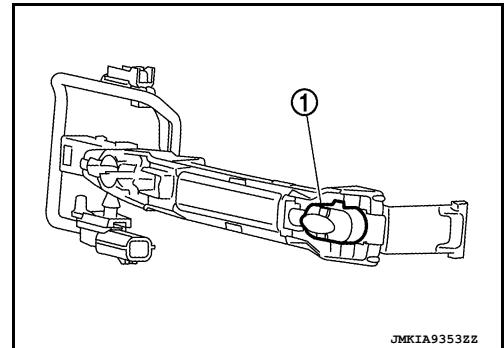

Front Door Request Switch (RH)

INFOID:000000013036957

- Front door request switch (RH) transmits door request switch signal to BCM.
- Front door request switch (RH) (1) is integrated into passenger side outside handle.

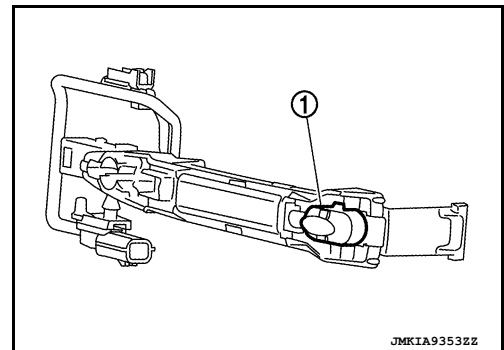

Front Door Switch

INFOID:000000013036958

Door switch detects open/close status of door and transmits door switch signal to BCM.

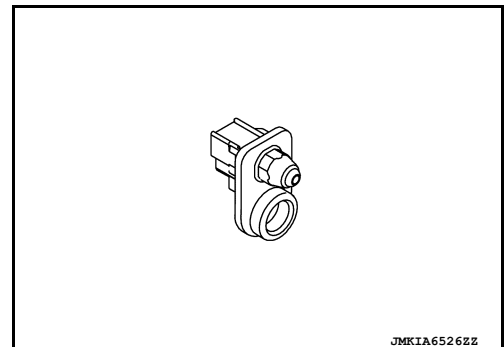

A
B
C
D
E
F
G
H
I
J
DLK
L
M
N
O
P

COMPONENT PARTS

< SYSTEM DESCRIPTION >

Rear Door Switch

INFOID:000000013036959

Door switch detects open/close status of door and transmits door switch signal to BCM.

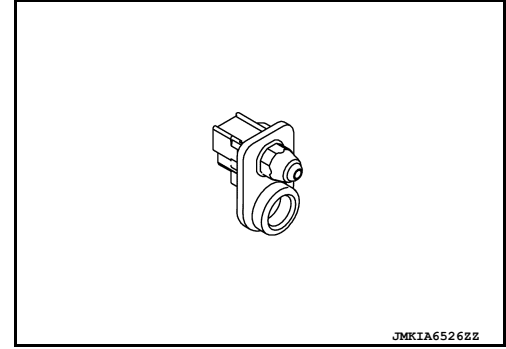

Front Door Lock Assembly (LH)

INFOID:000000013036960

- Door lock actuator and unlock sensor are integrated into driver door lock assembly.
- Door lock actuator receives lock/unlock signal from BCM and then locks/unlocks driver door.
- Only front door lock assembly (driver side) integrates unlock sensor. Unlock sensor transmits lock/unlock status of driver seat to BCM.

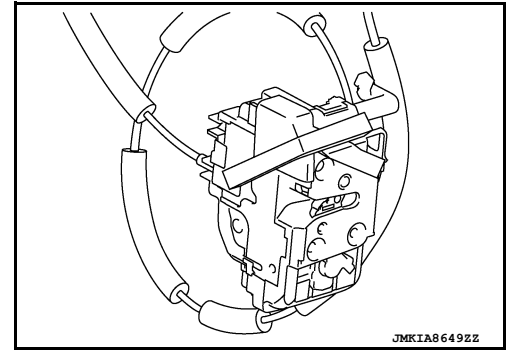

Integrated Homelink Transmitter

INFOID:000000013036962

Within the Homelink transmitter, a maximum of 3 radio signals can be stored and transmitted to operate the garage door, etc.

SYSTEM (POWER DOOR LOCK SYSTEM)

< SYSTEM DESCRIPTION >

SYSTEM (POWER DOOR LOCK SYSTEM)

System Description

INFOID:000000013036963

SYSTEM DIAGRAM

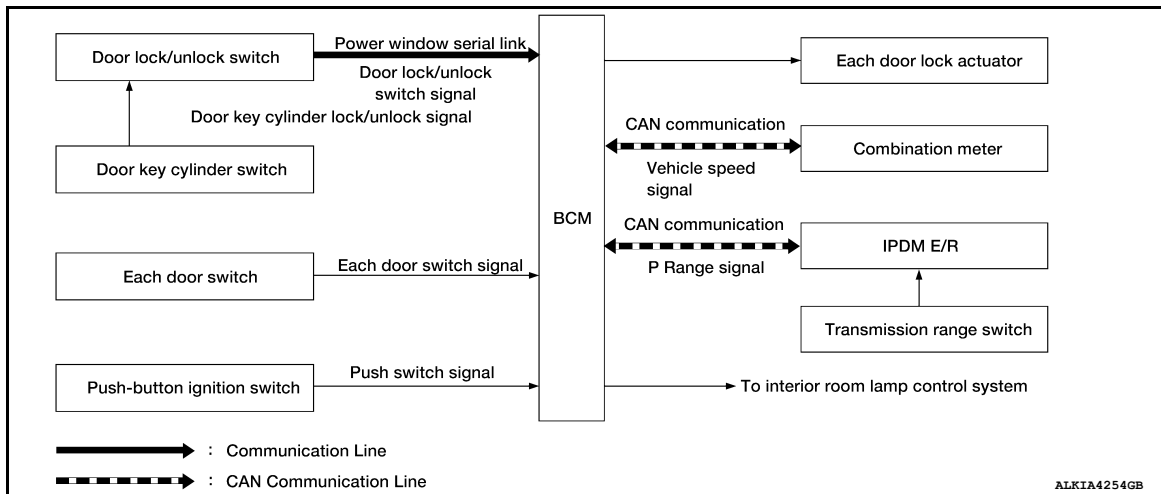

DOOR LOCK FUNCTION

Door Lock and Unlock Switch

- The door lock and unlock switch (driver side) is built into main power window and door lock/unlock switch.
- The door lock and unlock switch (passenger side) is built into power window and door lock/unlock switch RH.
- Interlocked with the locking operation of door lock and unlock switch, door lock actuators of all doors are locked.
- Interlocked with the unlocking operation of door lock and unlock switch, door lock actuators of all doors are unlocked.

Door Key Cylinder Switch

- With the mechanical key inserted into the door key cylinder on driver side, turning it to lock position locks door lock actuator of all doors.
- With the mechanical key inserted into the door key cylinder on driver side, turning it to unlock position once unlocks the driver side door and turning it to unlock position again within 60 seconds after the first unlock operation unlocks all of the other doors (SELECTIVE UNLOCK OPERATION).

Selective unlock operation mode can be changed using CONSULT.

Refer to [BCS-20. "DOOR LOCK : CONSULT Function \(BCM - DOOR LOCK\)".](#)

IGNITION POSITION WARNING FUNCTION

When door lock and unlock switch is operated while driver side door is open and ignition position is in ACC or ON, door locks once but immediately unlocks.

INTERIOR ROOM LAMP CONTROL FUNCTION

Interior room lamp is controlled according to door lock/unlock state. Refer to [INL-7. "INTERIOR ROOM LAMP CONTROL SYSTEM : System Description".](#)

AUTOMATIC DOOR LOCK/UNLOCK FUNCTION (LOCK OPERATION)

The interlock door lock function is the function that locks all doors linked with the vehicle speed or shift position. It has 2 types as per the following items:

Vehicle Speed Sensing Auto Door Lock

All doors are locked when the vehicle speed reaches 24 km/h (15 MPH) or more.

BCM outputs the lock signal to all door lock actuators when it detects that the ignition switch is turned ON, all doors are closed and the vehicle speed received from the combination meter via CAN communication becomes 24 km/h (15 MPH) or more.

P Range Interlock Door Lock

All doors are locked when shifting the selector lever from the P (Park) position to any position other than P (Park).

SYSTEM (POWER DOOR LOCK SYSTEM)

< SYSTEM DESCRIPTION >

BCM outputs the lock signal to all door lock actuators when it detects that the ignition switch is in the ON position, all doors are closed and the shift signal received from the park position switch when shifted from the P (Park) position to any position other than P (Park).

Setting Change of Automatic Door Lock/Unlock Function

The lock operation setting of the automatic door lock/unlock function can be changed.

With CONSULT

The ON/OFF switching of the automatic door lock function and the type selection of the automatic door lock/unlock function can be performed in the "Work support" mode.

Without CONSULT

The automatic door lock function ON/OFF can be switched by performing the following operation:

1. Close all doors (door switch OFF).
2. Ignition switch: OFF→ON
3. Press and hold the door lock and unlock switch for 5 seconds or more in the lock direction within 20 seconds after turning the ignition switch ON.
4. The switching is complete when the hazard lamp blinks as follows:

OFF → ON : 2 blinks

ON → OFF : 1 blink

AUTOMATIC DOOR LOCK/UNLOCK FUNCTION (UNLOCK OPERATION)

The automatic door lock/unlock function is the function that unlocks all doors linked with the key position or shift position. It has 2 types as per the following items:

IGN OFF Interlock Door Unlock

All doors are unlocked when the power supply position is changed from ON to OFF.

BCM outputs the unlock signal to all door lock actuators when it detects that the power supply position is changed from ignition switch ON to OFF.

P Range Interlock Door Unlock

All doors are unlocked when shifting the selector lever from any position other than P to the P position.

BCM outputs the unlock signal to all door lock actuators when it detects that the ignition switch is in the ON position and the shift signal received from park position switch when shifted from any position other than P to the P position.

Setting Change of Automatic Door Lock/Unlock Function

The unlock operation setting of the automatic door lock/unlock function can be changed.

With CONSULT

The ON/OFF switching of the automatic door lock/unlock function and the type selection of the automatic door lock/unlock function can be performed in the "Work support" mode.

Without CONSULT

The automatic door lock/unlock function ON/OFF can be switched by performing the following operation:

1. Close all doors (door switch OFF).
2. Ignition switch: OFF→ON
3. Press and hold the door lock and unlock switch for 5 seconds or more in the unlock direction within 20 seconds after turning the power supply position ON.
4. The switching is complete when the hazard lamp blinks as follows:

OFF → ON : 2 blinks

ON → OFF : 1 blink

SYSTEM (INTELLIGENT KEY SYSTEM)

< SYSTEM DESCRIPTION >

SYSTEM (INTELLIGENT KEY SYSTEM) INTELLIGENT KEY SYSTEM

INTELLIGENT KEY SYSTEM : System Description

INFOID:000000013036964

SYSTEM DIAGRAM

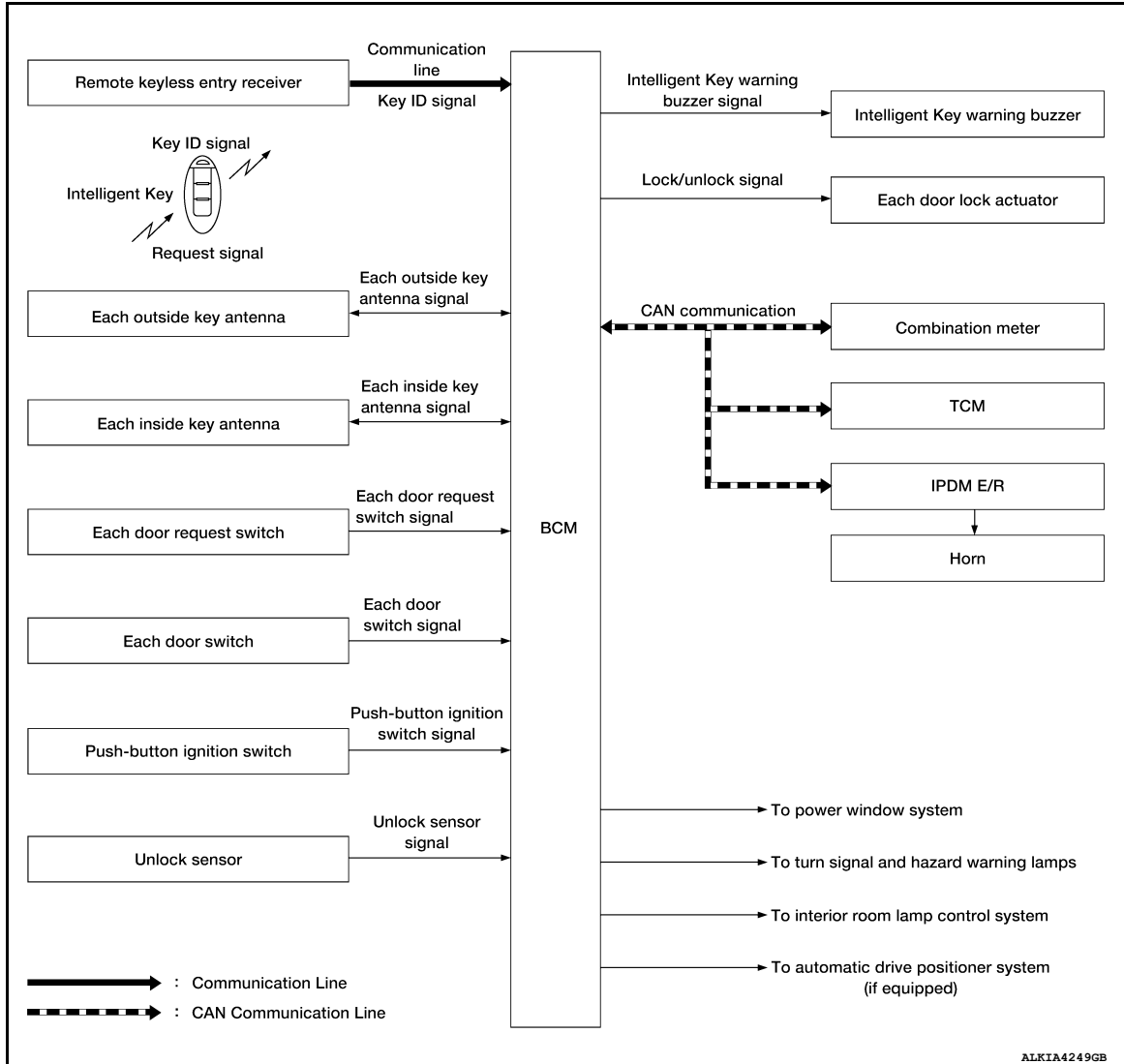

SYSTEM DESCRIPTION

- The Intelligent Key system is a system that makes it possible to lock and unlock the door locks (door lock/unlock function) by carrying the Intelligent Key, which operates based on the results of electronic ID verification using two-way communication between the Intelligent Key and the vehicle (BCM).

CAUTION:

The driver should always carry the Intelligent Key.

- The settings for each function can be changed with CONSULT.
- If an Intelligent Key is lost, a new Intelligent Key can be registered. A maximum of 4 Intelligent Keys can be registered.
- It is possible to perform a diagnosis on the system and register an Intelligent Key with CONSULT.
- For initialization and registration of Intelligent Keys, refer to CONSULT Immobilizer mode and follow the on-screen instructions.

Function	Description	Reference
Door lock	Lock/unlock can be performed by pressing the request switch.	DLK-19
Remote keyless entry	Lock/unlock can be performed by pressing the remote controller button of the Intelligent Key.	DLK-20

A
B
C
D
E
F
G
H
I
J
DLK
L
M
N
O
P

SYSTEM (INTELLIGENT KEY SYSTEM)

< SYSTEM DESCRIPTION >

Function	Description	Reference
Key reminder	The key reminder buzzer sounds a warning if the door is locked with the key left inside the vehicle.	DLK-24
Warning	If an action that does not meet the operating condition of the Intelligent Key system is taken, the buzzer sounds to inform the driver.	DLK-24
Interior room lamp control	Interior room lamp is controlled according to door lock/unlock state.	DLK-19
Panic alarm	When Intelligent Key panic alarm button is pressed, horn sounds.	DLK-24

DOOR LOCK FUNCTION

DOOR LOCK FUNCTION : System Description

INFOID:000000013036965

SYSTEM DIAGRAM

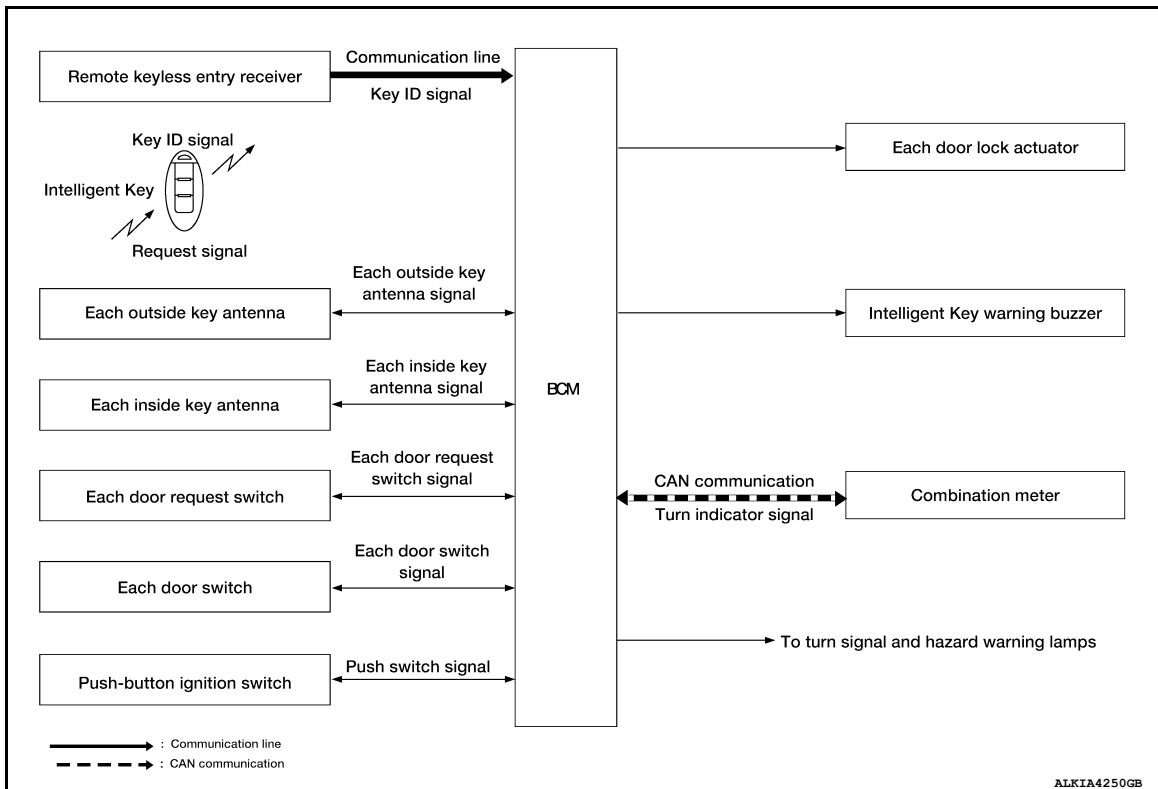

Only when pressing the door request switch it is possible to lock and unlock the door by carrying the Intelligent Key.

OPERATION DESCRIPTION

- When the BCM detects that each door request switch is pressed, it activates the outside key antenna and inside key antenna corresponding to the pressed door request switch and transmits the request signal to the Intelligent Key.
- If the Intelligent Key is within the outside key antenna detection area, it receives the request signal and transmits the key ID signal to the BCM via remote keyless entry receiver.
- BCM receives the key ID signal and compares it with the registered key ID.
- BCM locks/unlocks each door.
- BCM sounds Intelligent Key warning buzzer (lock: 2 times, unlock: 1 time) and blinks hazard warning lamps (lock: 2 times, unlock: 1 time) at the same time as a reminder.

OPERATION CONDITION

If the following conditions are satisfied, door lock/unlock operation is performed if the door request switch is operated:

SYSTEM (INTELLIGENT KEY SYSTEM)

< SYSTEM DESCRIPTION >

Each door request switch operation	Operation condition
Lock	<ul style="list-style-type: none"> All doors are closed. Panic alarm is not activated. P (Park) position warning is not activated. Intelligent Key is outside the vehicle. Intelligent Key is within outside key antenna detection area*.
Unlock	<ul style="list-style-type: none"> Panic alarm is not activated. Intelligent Key is outside the vehicle. Intelligent Key is within outside key antenna detection area*.

*: Even with a registered Intelligent Key remaining inside the vehicle, door locks can be locked/unlocked from outside the vehicle with a spare Intelligent Key as long as key IDs are different.

OUTSIDE KEY ANTENNA DETECTION AREA

The outside key antenna detection area of door lock/unlock function is in the range of approximately 80 cm (31.50 in) surrounding the driver and passenger door handles (1). However, this operating range depends on the ambient conditions.

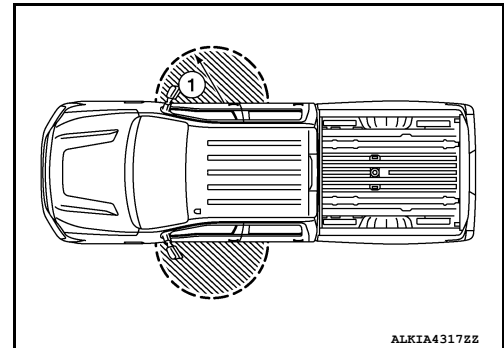

SELECTIVE UNLOCK FUNCTION

Lock Operation

When a LOCK signal is sent from door request switch (driver side, passenger side), all doors are locked.

Unlock Operation

- When an UNLOCK signal from driver side door request switch is transmitted, driver side door is unlocked. When another UNLOCK signal is transmitted within 60 seconds, all other doors are unlocked.
- When an UNLOCK signal from passenger side door request switch is transmitted, passenger side door is unlocked. When another UNLOCK signal is transmitted within 60 seconds, all other doors are unlocked.

How To Change Selective Unlock Operation Mode

Selective unlock operation mode can be changed using CONSULT.

Refer to [BCS-26, "INTELLIGENT KEY : CONSULT Function \(BCM - INTELLIGENT KEY\)"](#).

HAZARD AND BUZZER REMINDER FUNCTION

During lock or unlock operation by each door request switch, the hazard warning lamps blink and Intelligent Key warning buzzer honks as a reminder.

Operating Function of Hazard and Buzzer Reminder

Operation	Hazard warning lamp blinks	Intelligent Key warning buzzer honks
Unlock	Once	Once
Lock	Twice	Twice

Hazard and buzzer reminder does not operate in the following conditions:

- Ignition switch position is ON.
- Door is open (only lock operation).

How To Change Hazard And Buzzer Reminder Mode

Hazard and buzzer reminder mode can be changed using CONSULT.

Refer to [BCS-26, "INTELLIGENT KEY : CONSULT Function \(BCM - INTELLIGENT KEY\)"](#).

AUTO DOOR LOCK FUNCTION

After door is unlocked by door request switch operation and if 60 seconds or more pass without performing the following operation, all doors are automatically locked. However, operation check function does not activate.

SYSTEM (INTELLIGENT KEY SYSTEM)

< SYSTEM DESCRIPTION >

Operating condition	<ul style="list-style-type: none"> • Door switch is ON (door is open). • Door is locked. • Push switch is pressed.
---------------------	---

How To Change Auto Door Lock Operation Mode

Auto door lock operation mode can be changed using CONSULT.

Refer to [BCS-26, "INTELLIGENT KEY : CONSULT Function \(BCM - INTELLIGENT KEY\)"](#).

LIST OF OPERATION RELATED PARTS

Parts marked with × are the parts related to operation.

Function	Intelligent Key	Door switch	Door request switch	Door lock actuator	Inside key antenna	Outside key antenna	CAN communication system	BCM	Hazard warning lamp	Intelligent Key warning buzzer	Push-button ignition switch
Door lock/unlock function	×	×	×	×	×	×		×			
Hazard reminder function							×	×	×	×	
Selective unlock function	×		×	×	×	×		×			
Auto door lock function	×			×				×			×

REMOTE KEYLESS ENTRY FUNCTION

REMOTE KEYLESS ENTRY FUNCTION : System Description

INFOID:000000013036967

SYSTEM DIAGRAM

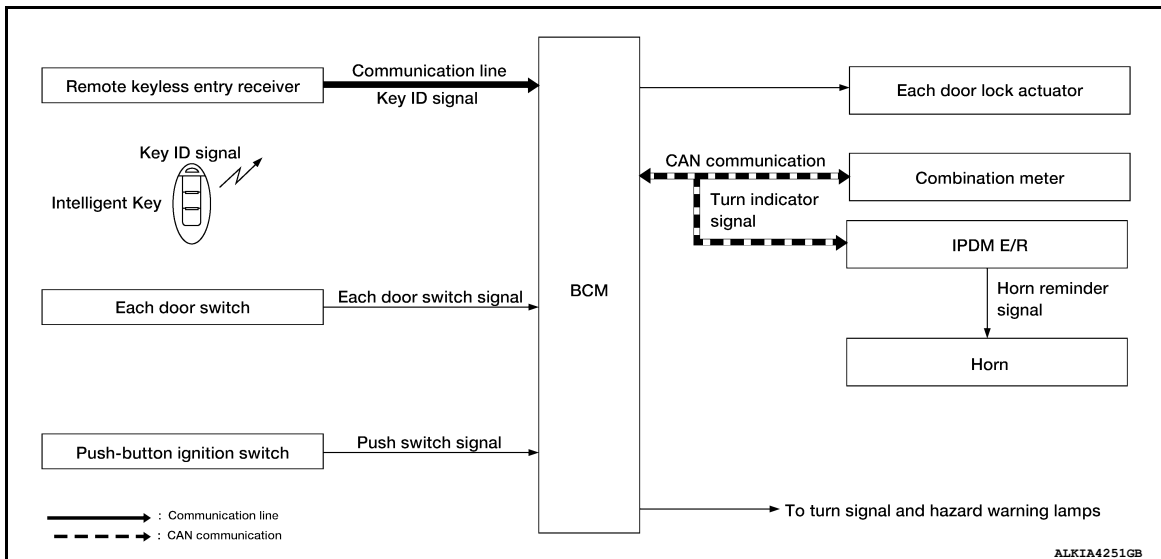

SYSTEM DESCRIPTION

The Intelligent Key has the same functions as the remote control entry system. Therefore, it can be used in the same manner as the remote controller by operating the door lock/unlock button.

OPERATION

Remote keyless entry system controls operation of the following items:

- Door lock/unlock function
- Selective unlock function
- Auto door lock function
- Hazard and horn reminder function

SYSTEM (INTELLIGENT KEY SYSTEM)

< SYSTEM DESCRIPTION >

- Remote engine start

OPERATION AREA

The remote keyless entry operating range is approximately 60 m (197 ft) from the vehicle.

DOOR LOCK/UNLOCK FUNCTION

- When door lock/unlock button of the Intelligent Key is pressed, lock signal or unlock signal is transmitted from Intelligent Key to BCM.
- When BCM receives the door lock/unlock signal, it operates all door lock actuators, blinks the hazard lamps (lock: 2 times, unlock: 1 time) and horn chirp signal to IPDM E/R at the same time as a reminder.
- IPDM E/R honks horn (lock: 1 time) as a reminder.

OPERATION CONDITION

If the following conditions are satisfied, remote keyless entry operation is performed when the Intelligent Key is operated:

Remote controller operation	Operation condition
Lock	<ul style="list-style-type: none"> • Panic alarm is not activated. • P (Park) position warning is not activated.
Unlock	<ul style="list-style-type: none"> • Panic alarm is not activated.

SELECTIVE UNLOCK FUNCTION

- When a LOCK signal is transmitted from Intelligent Key, all doors are locked.
- When an UNLOCK signal is transmitted from Intelligent Key once, driver side door is unlocked.
- Then, if an UNLOCK signal is transmitted from Intelligent Key again within 60 seconds, all other doors are unlocked.

How To Change Selective Unlock Operation Mode.

Selective unlock operation mode can be changed using CONSULT.

Refer to [BCS-20, "DOOR LOCK : CONSULT Function \(BCM - DOOR LOCK\)"](#).

AUTO DOOR LOCK FUNCTION

After door is unlocked by Intelligent Key button operation and if 60 seconds or more pass without performing the following operation, all doors are locked. However, operation check function does not activate.

Operating condition	
	<ul style="list-style-type: none"> • Door switch is ON (door is open). • Door is locked. • Push switch is pressed.

How To Change Auto Door Lock Operation Mode.

Auto door lock mode can be changed using CONSULT.

Refer to [BCS-26, "INTELLIGENT KEY : CONSULT Function \(BCM - INTELLIGENT KEY\)"](#).

HAZARD AND HORN REMINDER FUNCTION

When doors are locked or unlocked by Intelligent Key, BCM blinks hazard warning lamps as a reminder.

The hazard and horn reminder has a horn chirp mode (C mode) and a non-horn chirp mode (S mode).

Operating Function of Hazard and Horn Reminder

	C mode		S mode	
	Lock	Unlock	Lock	Unlock
Hazard warning lamps blink	Twice	Once	Twice	—
Horn sounds	Once	—	—	—

Hazard and horn reminder does not operate in the following conditions:

- Ignition switch position is ON.
- Door is open (only lock operation).

How to Change Hazard and Horn Reminder Mode

With CONSULT

Hazard and horn reminder operation mode can be changed using CONSULT.

Refer to [BCS-26, "INTELLIGENT KEY : CONSULT Function \(BCM - INTELLIGENT KEY\)"](#).

Without CONSULT

A
B
C
D
E
F
G
H
I
J
L
M
N
O
P

DLK

SYSTEM (INTELLIGENT KEY SYSTEM)

< SYSTEM DESCRIPTION >

When LOCK and UNLOCK signals are sent from the Intelligent Key for more than 2 seconds at the same time, the hazard and horn reminder mode is changed and hazard warning lamps blink and horn sounds as per the following items:

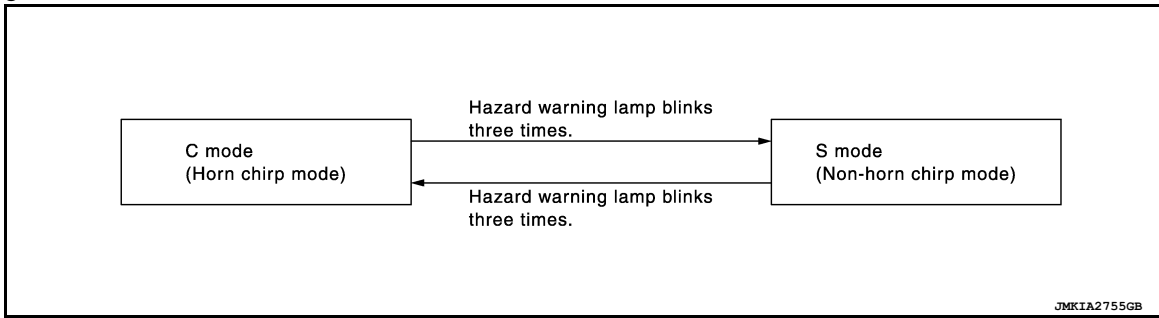

LIST OF OPERATION RELATED PARTS

Parts marked with × are the parts related to operation.

Function	Intelligent Key	Door switch	Door lock actuator	Push-button ignition switch	CAN communication system	BCM	IPDM E/R	Horn	Combination meter	Hazard warning lamp
Door lock/unlock function	×	×	×			×				
Selective unlock function	×	×	×			×				
Hazard and horn reminder function					×	×	×	×	×	×

WARNING FUNCTION

WARNING FUNCTION : System Description

INFOID:0000000013036968

OPERATION DESCRIPTION

The warning functions are as per the following items and are given to the user as warning information and warnings using combinations of Intelligent Key warning buzzer, combination meter buzzer, KEY warning lamp and information display in combination meter:

- Intelligent Key system malfunction
- OFF position warning
- P position warning
- Take away warning
- Door lock operation warning
- Engine start information
- Intelligent Key low battery warning
- Key ID warning
- Key ID verification information

OPERATION CONDITION

Once the following condition from below is established, alert or warning is executed:

SYSTEM (INTELLIGENT KEY SYSTEM)

< SYSTEM DESCRIPTION >





Warning/Information functions		Operation procedure	
Intelligent Key system malfunction		When a malfunction is detected on BCM, "KEY" warning lamp illuminates.	A
OFF position warning	For internal	When condition A, B or C is satisfied: <ul style="list-style-type: none"> • Condition A - Ignition switch: ACC position - Door switch (driver side): ON (Door is open.) • Condition B - Turn ignition switch from ON to OFF while door is open. • Condition C - Intelligent Key backside is contacted to ignition switch while brake pedal is depressed and ignition switch is in LOCK or OFF (when the Intelligent Key battery is discharged.) - Door switch (driver side): ON (Door is open.) 	B C
	For external	OFF position warning (for internal) is in active mode and driver side door is closed. NOTE: OFF position (for external) active only when each of the sequence occurs as below: P position warning → ACC warning → OFF position warning (for internal) → OFF position warning (for internal)	D E
P position warning	For internal	<ul style="list-style-type: none"> • Shift position: Except P (Park) position • Engine is running to stopped (ignition switch is ON to OFF.) 	F
	For external	Warning is activated when driver door is closed from the open position while the P (Park) position warning (for inside vehicle) is ON.	G
ACC warning		<ul style="list-style-type: none"> • When P (Park) position warning is in active mode, shift position changes P (Park) position. • Ignition switch: ACC position 	H
Take away warning	Door is open to closed	<ul style="list-style-type: none"> • Ignition switch: Except Lock position • Door switch: ON to OFF (Door is open to close.) • Intelligent Key cannot be detected inside the vehicle. 	I
	Door is open.	<ul style="list-style-type: none"> • Ignition switch: Except Lock position • Door switch: ON (Door is open.) • Key ID verification every 5 seconds when registered Intelligent Key cannot be detected inside the vehicle. 	J
	Push-button ignition switch operation	<ul style="list-style-type: none"> • Ignition switch: Except Lock position • Press push-button ignition switch. • Intelligent Key cannot be detected inside the vehicle. 	DLK
Door lock operation warning		When door lock operation is requested while door lock operating conditions of door request switch or Intelligent Key are not satisfied.	L
Engine start information	Ignition switch is in ON position.	<ul style="list-style-type: none"> • Ignition switch: ON position • Shift position: P (Park) position • Engine is stopped. 	M
	Ignition switch is in except ON position.	<ul style="list-style-type: none"> • Ignition switch: Except ON position • Shift position: P (Park) position • Intelligent Key is inserted in key slot or Intelligent Key can be detected inside the vehicle. 	N
Intelligent Key low battery warning		When Intelligent Key is low battery, BCM is detected after ignition switch is turned ON.	O
Key ID warning		When registered Intelligent Key cannot be detected inside the vehicle after ignition switch is turned ON.	P
Key ID verification information		<ul style="list-style-type: none"> • When registered Intelligent Key cannot be detected inside the vehicle • Intelligent Key battery is discharged • When NATS antenna amp. cannot detect NATS ID. 	

WARNING METHOD

The following table shows the alarm or warning methods with chime:

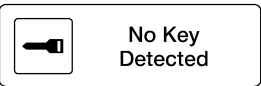
SYSTEM (INTELLIGENT KEY SYSTEM)

< SYSTEM DESCRIPTION >

Warning/Information functions		"KEY" warning lamp	Information display (combination meter)	Warning chime	
				Combination meter buzzer	Intelligent Key warning buzzer
Intelligent Key system malfunction		Indicate	—	—	—
OFF position warning	For internal	—	—	Activate	—
	For external	—	—	—	Activate
P position warning	For internal	—	 Shift to Park	Activate	—
	For external			—	Active
		<small>ALKIA2515GB</small>			
Take away warning	Door is open to closed.	—	 No Key Detected	Activate	Activate
	Door is open.			—	—
	Push-button ignition switch operation			Activate	—
		<small>ALKIA2517GB</small>			
Door lock operation warning	Request switch operation	—	—	—	Activate
	Intelligent Key	—	—	—	Activate
Key ID warning		—	 Key ID Incorrect	—	—
		<small>ALKIA2518GB</small>			
Intelligent Key low battery warning		—	 Key low battery	—	—
		<small>ALKIA2520GB</small>			
Key ID verification information		—		—	—
		<small>ALKIA2521ZZ</small>			

LIST OF OPERATION RELATED PARTS

Parts marked with × are the parts related to operation.

SYSTEM (INTELLIGENT KEY SYSTEM)

< SYSTEM DESCRIPTION >

Warning function		Intelligent Key	Ignition switch	Door switch	Door request switch	Inside key antenna	Outside key antenna	Intelligent Key warning buzzer	Combination meter buzzer	CAN communication system	BCM	Information display	"KEY" warning lamp
Intelligent Key system malfunction										x	x		x
OFF position warning	For internal			x					x	x	x		
	For external			x				x			x		
P (Park) position warning			x						x	x	x	x	x
Take away warning	Door is open or closed.	x		x		x		x	x	x	x	x	x
	Door is open.	x		x		x				x	x	x	x
	Push-button ignition switch operation	x	x			x			x	x	x	x	x
Door lock operation warning		x		x	x	x	x	x			x		
Key ID warning			x			x				x	x	x	x
Engine start information	Ignition switch is in ON position.	x	x			x				x	x	x	
	Ignition switch is in except ON position.	x	x			x				x	x	x	
Intelligent Key low battery warning		x				x				x	x	x	x
Key ID verification information		x				x				x	x	x	

KEY REMINDER FUNCTION

KEY REMINDER FUNCTION : System Description

INFOID:000000013036969

SYSTEM DIAGRAM

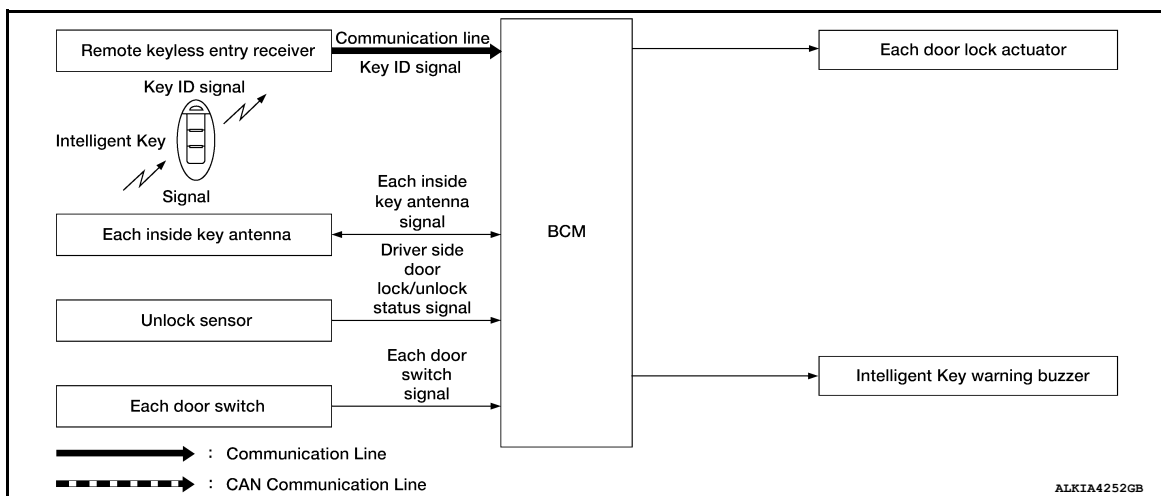

SYSTEM DESCRIPTION

Key reminder is the function that prevents the key from being left in the vehicle. Key reminder has the following 3 functions:

SYSTEM (INTELLIGENT KEY SYSTEM)

< SYSTEM DESCRIPTION >

Key reminder function	Operation condition	Operation
Driver door is closed*.	Right after driver door is closed under the following conditions: <ul style="list-style-type: none"> • Door lock operation is performed. • Driver side door is open. • Driver side door is in lock state. 	All doors.
Door is open or closed.	Right after all doors are closed under the following conditions: <ul style="list-style-type: none"> • Intelligent Key is inside the vehicle. • Any door is open. • All doors (except for back door) are locked by door lock and unlock switch or door lock knob. 	<ul style="list-style-type: none"> • All doors. • Honk Intelligent Key warning buzzer.

*: If the door closing impact shocks the door lock knob or contacts against baggage, the door lock knob might activate the door locks accidentally but unlock operation is performed in these cases.

CAUTION:

- The above function operates when the Intelligent Key is inside the vehicle. However, there may be times when the Intelligent Key cannot be detected. This function does not operate when the Intelligent Key is on the instrument panel, rear parcel shelf or in the glove box. Also, this system sometimes does not operate if the Intelligent Key is in the door pocket of the open door.

REMOTE ENGINE START FUNCTION

REMOTE ENGINE START FUNCTION : System Description

INFOID:000000013036970

SYSTEM DIAGRAM

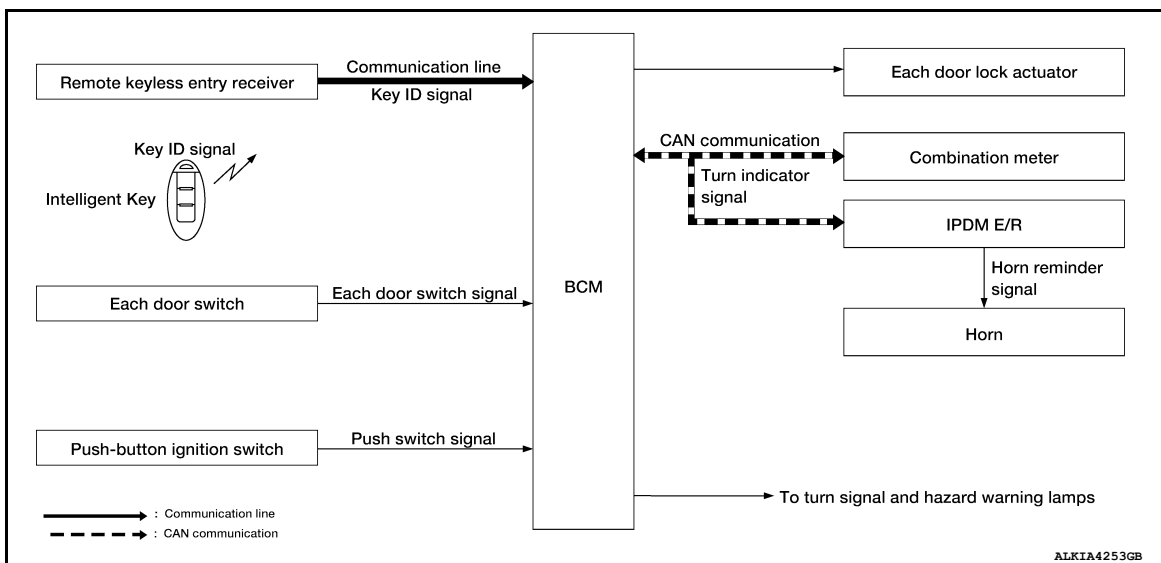

OPERATION

Remote keyless entry system controls operation of the following items:

- Door lock/unlock function
- Selective unlock function
- Auto door lock function
- Hazard and horn reminder function
- Remote engine start

OPERATION AREA

The remote engine start operating range is approximately 60 m (197 ft) from the vehicle but not inside the vehicle.

REMOTE ENGINE START FUNCTION

- The remote engine start function is activated when the lock button of the Intelligent Key is pressed and released, and then within 5 seconds, the remote engine start button is pressed and held for at least 2 seconds. At this time, a start signal is transmitted from the Intelligent Key to the BCM via the remote keyless entry receiver.
- When the BCM receives the lock signal, it locks all doors and the fuel lid, flashes the hazard lamps and chirps the horn (the horn will chirp only if the answer back horn feature is activated).

SYSTEM (INTELLIGENT KEY SYSTEM)

< SYSTEM DESCRIPTION >

- When the BCM receives a successful remote engine start signal, the turn signals will flash once and the parking/tail lamps will come on.
- To enter normal engine run mode from inside the vehicle, depress and hold the brake pedal then press the push-button ignition switch.
- To cancel the remote engine start mode away from the vehicle, press the remote engine start button on the Intelligent Key.
- Once the vehicle has been started using the remote engine start feature, it will remain running for 10 minutes. Extended run time can be added to the initial 10 minute running time by first pressing and releasing the lock button and then within 5 seconds, pressing and holding the remote engine start button for at least 2 seconds. The turn signals will flash once and an additional 10 minutes of running time will be added. The additional 10 minutes start when the extended run time is activated. Extended time can only be added once for a maximum run time of up to 20 minutes.

Additional remote engine start cancel operations	<ul style="list-style-type: none"> • Anti-theft alarm is activated - unauthorized entry. • Maximum time for engine to run by remote start has been exceeded. • Hazard lamps are turned on. • Push-button ignition switch is pressed without the Intelligent Key in the vehicle. • Push-button ignition switch is pressed without depressing the brake pedal first. • The hood is opened while the remote engine start is engaged. • The vehicle has been moved out of park before "brake and push" action is completed.
Limitations/Restrictions	<ul style="list-style-type: none"> • Remote engine start must be set to ON within Vehicle Settings in the combination meter. • Engine must be stopped (0 rpm) before engine can be remotely started. <ul style="list-style-type: none"> - Must wait for 6 seconds or more after IGN RUN → OFF. • Remote engine start can only be activated up to 2 times. <ul style="list-style-type: none"> - Remote engine start extended time counts as 1 remote engine start activation. - Cycling IGN via push-button ignition switch resets this counter. • User has 5 seconds to press and hold remote engine start button after lock button is pressed. • Remote engine start must be pressed and held for 2 seconds or more after lock button is pressed. • Maximum remote start time is 20 minutes (this includes remote engine start extended time). • Operation area is approximately 60 m (197 ft) from the vehicle but not inside the vehicle. • The push-button ignition switch must not be in the ACC or ON position. • The vehicle must be in Park. • Hazard flashers must not be on. • There must not be any registered Intelligent Keys inside the vehicle. • Brakes must not be pressed when attempting to activate remote engine start. <ul style="list-style-type: none"> - Improper remote engine start operation can occur when stop lamp switch is misadjusted or inoperative. • The doors must be closed. • The hood must be closed. • No current DTCs in the BCM can be present.

HAZARD AND HORN REMINDER FUNCTION

When remote engine start is initiated by Intelligent Key, BCM blinks hazard warning lamps as a reminder. The hazard and horn reminder has a horn chirp mode (C mode) and a non-horn chirp mode (S mode).

Operating Function of Hazard and Horn Reminder

	C mode		S mode	
Intelligent Key operation	Lock	Unlock	Lock	Unlock
Hazard warning lamps blink	Twice	Once	Twice	—
Horn sounds	Once	—	—	—

Hazard and horn reminder does not operate in the following conditions:

- Ignition switch position is ON.
- Door is open (only lock operation).

How to Change Hazard and Horn Reminder Mode

Ⓜ With CONSULT

Hazard and horn reminder operation mode can be changed using CONSULT.

Refer to [BCS-26, "INTELLIGENT KEY : CONSULT Function \(BCM - INTELLIGENT KEY\)"](#).

ⓧ Without CONSULT

SYSTEM (INTELLIGENT KEY SYSTEM)

< SYSTEM DESCRIPTION >

When LOCK and UNLOCK signals are sent from the Intelligent Key for more than 2 seconds at the same time, the hazard and horn reminder mode is changed and hazard warning lamps blink and horn sounds as per the following items:

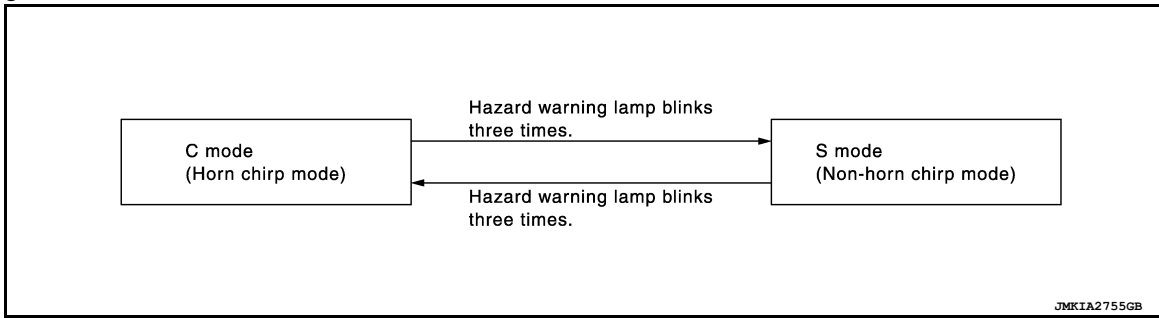

LIST OF OPERATION RELATED PARTS

Parts marked with × are the parts related to operation.

Function	Intelligent Key	Door switch	Door lock actuator	Fuel lid lock actuator	Push-button ignition switch	CAN communication system	BCM	IPDM E/R	Horn	Combination meter	Hazard warning lamp
Door lock/unlock function	×	×	×	×			×				
Selective unlock function	×	×	×	×			×				
Auto door lock function	×	×	×	×	×		×				
Hazard and horn reminder function						×	×	×	×	×	×
Remote engine start function	×			×	×	×	×	×	×		×

SYSTEM (INTEGRATED HOMELINK TRANSMITTER)

< SYSTEM DESCRIPTION >

SYSTEM (INTEGRATED HOMELINK TRANSMITTER)

System Description

INFOID:000000013036971

Item	Function
Integrated Homelink® transmitter	A maximum of 3 radio signals can be stored and transmitted to operate the garage door, etc.

A
B
C
D
E
F
G
H
I
J
DLK
L
M
N
O
P

DIAGNOSIS SYSTEM (BCM)

< SYSTEM DESCRIPTION >

DIAGNOSIS SYSTEM (BCM)

COMMON ITEM

COMMON ITEM : CONSULT Function (BCM - COMMON ITEM)

INFOID:000000013052201

APPLICATION ITEM

CONSULT performs the following functions via CAN communication with BCM.

Direct Diagnostic Mode	Description
ECU Identification	The BCM part number is displayed.
Self Diagnostic Result	The BCM self diagnostic results are displayed.
Data Monitor	The BCM input/output data is displayed in real time.
Active Test	The BCM activates outputs to test components.
Work support	The settings for BCM functions can be changed.
Configuration	<ul style="list-style-type: none"> The vehicle specification can be read and saved. The vehicle specification can be written when replacing BCM.
CAN Diag Support Mntr	The result of transmit/receive diagnosis of CAN communication is displayed.

SYSTEM APPLICATION

BCM can perform the following functions:

System	Sub System	Direct Diagnostic Mode						
		ECU Identification	Self Diagnostic Result	Data Monitor	Active Test	Work support	Configuration	CAN Diag Support Mntr
Door lock	DOOR LOCK		×	×	×	×		
Rear window defogger	REAR DEFOGGER			×	×	×		
Warning chime	BUZZER			×	×			
Interior room lamp timer	INT LAMP			×	×	×		
Exterior lamp	HEADLAMP			×	×	×		
Wiper and washer	WIPER			×	×	×		
Turn signal and hazard warning lamps	FLASHER			×	×	×		
Air conditioner	AIR CONDITIONER			×				
Intelligent Key system	INTELLIGENT KEY		×	×	×	×		
Combination switch	COMB SW			×				
BCM	BCM	×	×			×	×	×
Immobilizer	IMMU		×	×	×			
Interior room lamp battery saver	BATTERY SAVER			×	×			
Vehicle security system	THEFT ALM			×	×	×		
RAP system	RETAINED PWR			×				
Signal buffer system	SIGNAL BUFFER			×				

FREEZE FRAME DATA (FFD)

The BCM records the following vehicle condition at the time a particular DTC is detected, and displays it on CONSULT.

DIAGNOSIS SYSTEM (BCM)

< SYSTEM DESCRIPTION >

CONSULT screen item	Indication/Unit	Description		
Vehicle Speed	km/h	Vehicle speed at the moment a particular DTC is detected		A
Odo/Trip Meter	km	Total mileage (Odometer value) at the moment a particular DTC is detected		B
Vehicle Condition	SLEEP>LOCK	Power position status at the moment a particular DTC is detected*	While turning BCM status from low power consumption mode to normal mode (Power supply position is "LOCK"*).	B
	SLEEP>OFF		While turning BCM status from low power consumption mode to normal mode (Power supply position is "OFF".)	C
	LOCK>ACC		While turning power supply position from "LOCK" *to "ACC"	D
	ACC>ON		While turning power supply position from "ACC" to "IGN"	D
	RUN>ACC		While turning power supply position from "RUN" to "ACC" (Vehicle is stopped and selector lever is in P position.)	E
	CRANK>RUN		While turning power supply position from "CRANKING" to "RUN" (From cranking up the engine to run it)	E
	RUN>URGENT		While turning power supply position from "RUN" to "ACC" (Emergency stop operation)	F
	ACC>OFF		While turning power supply position from "ACC" to "OFF"	F
	OFF>LOCK		While turning power supply position from "OFF" to "LOCK"*	G
	OFF>ACC		While turning power supply position from "OFF" to "ACC"	G
	ON>CRANK		While turning power supply position from "IGN" to "CRANKING"	H
	OFF>SLEEP		While turning BCM status from normal mode (Power supply position is "OFF".) to low power consumption mode	H
	LOCK>SLEEP		While turning BCM status from normal mode (Power supply position is "LOCK"*.) to low power consumption mode	I
	LOCK		Power supply position is "LOCK" (Ignition switch OFF)*	I
	OFF		Power supply position is "OFF" (Ignition switch OFF)	J
	ACC		Power supply position is "ACC" (Ignition switch ACC)	J
	ON		Power supply position is "IGN" (Ignition switch ON with engine stopped)	J
ENGINE RUN	Power supply position is "RUN" (Ignition switch ON with engine running)	DLK		
CRANKING	Power supply position is "CRANKING" (At engine cranking)	DLK		
IGN Counter	0 - 39	The number of times that ignition switch is turned ON after DTC is detected <ul style="list-style-type: none"> • The number is 0 when a malfunction is detected now. • The number increases like 1 → 2 → 3...38 → 39 after returning to the normal condition whenever ignition is switched OFF → ON. • The number is fixed to 39 until the self-diagnosis results are erased if it is over 39. 		L

NOTE:

*: Power supply position shifts to "LOCK" from "OFF", when ignition switch is in the OFF position, selector lever is in the P position, and any of the following conditions are met:

- Closing door
- Opening door
- Door is locked using door request switch
- Door is locked using Intelligent Key

The power supply position shifts to "ACC" when the push-button ignition switch (push switch) is pushed at "LOCK".

DOOR LOCK

DOOR LOCK : CONSULT Function (BCM - DOOR LOCK)

INFOID:000000013052202

SELF DIAGNOSTIC RESULT

Refer to [BCS-52, "DTC Index"](#).

DATA MONITOR

DIAGNOSIS SYSTEM (BCM)

< SYSTEM DESCRIPTION >

Monitor Item [Unit]	Description
REQ SW-DR [On/Off]	Indicates condition of door request switch LH.
REQ SW-AS [On/Off]	Indicates condition of door request switch RH.
DOOR SW-DR [On/Off]	Indicates condition of front door switch LH.
DOOR SW-AS [On/Off]	Indicates condition of front door switch RH.
DOOR SW-RR [On/Off]	Indicates condition of rear door switch RH.
DOOR SW-RL [On/Off]	Indicates condition of rear door switch LH.
CDL LOCK SW [On/Off]	Indicates condition of lock signal from door lock and unlock switch.
CDL UNLOCK SW [On/Off]	Indicates condition of unlock signal from door lock and unlock switch.
KEY CYL LK-SW [On/Off]	Indicates condition of lock signal from door key cylinder switch.
KEY CYL UN-SW [On/Off]	Indicates condition of unlock signal from door key cylinder switch.

ACTIVE TEST

Test Item	Description
DOOR LOCK	This test is able to check door lock operation [ALL LOCK/ALL UNLK].

WORK SUPPORT

Support Item	Setting	Description
DOOR LOCK-UNLOCK SET	On*	Automatic door locks function ON.
	Off	Automatic door locks function OFF.
AUTO UNLOCK TYPE	MODE2	Driver door only unlocks automatically.
	MODE1*	All doors unlock automatically.
AUTO LOCK FUNCTION	MODE3	This mode is not used.
	MODE2	Doors lock automatically when shifted out of P (park).
	MODE1*	Doors lock automatically when vehicle speed reaches 24 km/h (15 mph).
	Off	—
AUTO UNLOCK FUNCTION	MODE3	This mode is not used.
	MODE2*	Doors unlock automatically when shifted into P (park).
	MODE1	Doors unlock automatically when ignition is switched from ON to OFF.
	Off	—
SIGNATURE LIGHT SETTING	On*	Signature light setting ON.
	Off	Signature light setting OFF.

* : Initial setting

INTELLIGENT KEY

INTELLIGENT KEY : CONSULT Function (BCM - INTELLIGENT KEY)

INFOID:000000013052203

SELF DIAGNOSTIC RESULT

Refer to [BCS-52. "DTC Index"](#).

DATA MONITOR

Monitor Item [Unit]	Main	Description
REQ SW -DR [On/Off]	×	Indicates condition of door request switch LH.
REQ SW -AS [On/Off]	×	Indicates condition of door request switch RH.
PUSH SW [On/Off]		Indicates condition of push-button ignition switch.

DIAGNOSIS SYSTEM (BCM)

< SYSTEM DESCRIPTION >

Monitor Item [Unit]	Main	Description	
SHIFTLOCK SOLENOID PWR SUPPLY [On/Off]	×	Indicates condition of power supply to shiftlock solenoid.	A
BRAKE SW 1 [On/Off]	×	Indicates condition of brake switch.	B
BRAKE SW 2 [On/Off]		Indicates condition of brake switch.	
DETE/CANCL SW [On/Off]	×	Indicates condition of P (park) position.	C
SFT PN/N SW [On/Off]	×	Indicates condition of P (park) or N (neutral) position.	
UNLK SEN -DR [On/Off]	×	Indicates condition of door unlock sensor.	
PUSH SW -IPDM [On/Off]		Indicates condition of push-button ignition switch received from IPDM E/R on CAN communication line.	D
IGN RLY1 -F/B [On/Off]		Indicates condition of ignition relay 1 received from IPDM E/R on CAN communication line.	E
DETE SW -IPDM [On/Off]		Indicates condition of park position switch received from TCM on CAN communication line.	F
SFT PN -IPDM [On/Off]		Indicates condition of P (park) or N (neutral) position from TCM on CAN communication line.	G
SFT P -MET [On/Off]		Indicates condition of P (park) position from TCM on CAN communication line.	
SFT N -MET [On/Off]		Indicates condition of N (neutral) position from IPDM E/R on CAN communication line.	H
ENGINE STATE [Stop/Start/Crank/Run]	×	Indicates condition of engine state from ECM on CAN communication line.	
VEH SPEED 1 [mph/km/h]	×	Indicates condition of vehicle speed signal received from ABS on CAN communication line.	I
VEH SPEED 2 [mph/km/h]	×	Indicates condition of vehicle speed signal received from combination meter on CAN communication line.	J
DOOR STAT -DR [LOCK/READY/UNLK]	×	Indicates condition of driver side door status.	
DOOR STAT -AS [LOCK/READY/UNLK]	×	Indicates condition of passenger side door status.	
DOOR STAT -RR [LOCK/READY/UNLK]	×	Indicates condition of rear right side door status.	
DOOR STAT -RL [LOCK/READY/UNLK]	×	Indicates condition of rear left side door status.	
ID OK FLAG [Set/Reset]		Indicates condition of Intelligent Key ID.	DLK
PRMT ENG STRT [Set/Reset]		Indicates condition of engine start possibility.	
PRMT RKE STRT [Set/Reset]		Indicates condition of engine start possibility from Intelligent Key.	
I-KEY OK FLAG [Key ON/Key OFF]	×	Indicates condition of Intelligent Key OK flag.	L
PRBT ENG STRT [Set/Reset]		Indicates condition of engine start prohibit.	
ID AUTHENTICATION CANCEL TIMER [under a stop]		Indicates condition of Intelligent Key ID authentication.	M
ACC BATTERY SAVER [under a stop]		Indicates condition of battery saver.	
CRNK PRBT TMR [On/Off]		Indicates condition of crank prohibit timer.	
AUT CRNK TMR [On/Off]		Indicates condition of automatic engine crank timer from Intelligent Key.	N
CRNK PRBT TME [sec]		Indicates condition of crank prohibit timer.	
AUT CRNK TMR [sec]		Indicates condition of automatic engine crank timer from Intelligent Key.	O
CRANKING TME [sec]		Indicates condition of engine cranking time from Intelligent Key.	
ST RLY -REQ		Indicates condition of starter relay.	
IGN RLY 1 -REQ		Indicates condition of ignition 1 relay.	P
IGN RLY 2 -REQ		Indicates condition of ignition 2 relay.	
DETE SW PWR [On/Off]		Indicates condition of park position switch voltage.	
ACC RLY -REQ [On/Off]		Indicates condition of accessory relay control request.	
RKE OPE COUN1 [0-19]	×	When remote keyless entry receiver receives the signal transmitted while operating on Intelligent Key, the numerical value start changing.	

DIAGNOSIS SYSTEM (BCM)

< SYSTEM DESCRIPTION >

Monitor Item [Unit]	Main	Description
RKE OPE COUN2 [0-19]	×	When remote keyless entry receiver receives the signal transmitted while operating on Intelligent Key, the numerical value start changing.
RKE-LOCK [On/Off]		Indicates condition of lock signal from Intelligent Key.
RKE-UNLOCK [On/Off]		Indicates condition of unlock signal from Intelligent Key.
RKE-PANIC [On/Off]		Indicates condition of panic signal from Intelligent Key.
RKE-MODE CHG [On/Off]		Indicates condition of mode change signal from Intelligent Key.

ACTIVE TEST

Test Item	Description
INTELLIGENT KEY LINK (CAN)	This test is able to check Intelligent Key identification number [Off/ID No1/ID No2/ID No3/ID No4/ID No5].
INT LAMP	This test is able to check interior room lamp operation [On/Off].
FLASHER	This test is able to check hazard lamp operation [LH/RH/Off].
HORN	This test is able to check horn operation [On].
BATTERY SAVER	This test is able to check battery saver operation [On/Off].
OUTSIDE BUZZER	This test is able to check Intelligent Key warning buzzer operation [On/Off].
INSIDE BUZZER	This test is able to check combination meter warning chime operation [Take Out/Knob/Key/Off].
INDICATOR	This test is able to check combination meter warning lamp operation [KEY ON/KEY IND/Off].
IGN CONT2	This test is able to check ignition relay-2 control operation [On/Off].
ENGINE SW ILLUMI	This test is able to check push-button ignition switch START indicator operation [On/Off].
PUSH SWITCH INDICATOR	This test is able to check push-button ignition switch indicator operation [On/Off].
ACC CONT	This test is able to check accessory relay control operation [On/Off].
IGN CONT1	This test is able to check ignition relay-1 control operation [On/Off].
ST CONT LOW	This test is able to check starter control relay operation [On/Off].
IGNITION RELAY	This test is able to check ignition relay operation [On/Off].
TRUNK/LUGGAGE LAMP TEST	This test is able to check cargo lamp illumination operation [On/Off].
KEYFOB PW TEST	This test is able to check power window operation using the Intelligent Key [P/W up/down OFF/Send P/W down ON/Send P/W up ON].
SHIFTLOCK SOLENOID TEST	This test is able to check shift lock solenoid operation [On/Off].

WORK SUPPORT

Support Item	Setting	Description
IGN/ACC BATTERY SAVER	On*	Battery saver function ON.
	Off	Battery saver function OFF.
REMOTE ENGINE STARTER	On*	Remote engine start function ON.
	Off	Remote engine start function OFF.
ANSWERBACK I-KEY LOCK UNLOCK	BUZZER*	Buzzer reminder function by door lock/unlock request switch ON.
	HORN	Horn chirp reminder function by door lock request switch ON.
	Off	No reminder function by door lock/unlock request switch.
ANSWERBACK KEYLESS LOCK UNLOCK	INVALID	This mode is not used.
	On*	Buzzer or horn chirp reminder when doors are locked/unlocked with Intelligent Key.
	Off	No buzzer or horn chirp reminder when doors are locked/unlocked with Intelligent Key.

DIAGNOSIS SYSTEM (BCM)

< SYSTEM DESCRIPTION >

Support Item	Setting	Description		
ANSWER BACK	On*	Horn chirp reminder when doors are locked with Intelligent Key.	A	
	Off	No horn chirp reminder when doors are locked with Intelligent Key.		
RETRACTABLE MIRROR SET	On	Retractable mirror set ON.	B	
	Off*	Retractable mirror set OFF.		
LOCK/UNLOCK BY I-KEY	On*	Door lock/unlock function from Intelligent Key ON.	C	
	Off	Door lock/unlock function from Intelligent Key OFF.		
ENGINE START BY I-KEY	On*	Engine start function from Intelligent Key ON.	D	
	Off	Engine start function from Intelligent Key OFF.		
CONFIRM KEY FOB ID	—	Intelligent Key ID code can be checked.		
SHORT CRANKING OUTPUT	Start	70 msec	Starter motor operation duration times.	E
		100 msec		
		200 msec		
	End	—	F	
INSIDE ANT DIAGNOSIS	—	This function allows inside key antenna self-diagnosis.		
AUTO LOCK SET	MODE7	5 min	Auto door lock time can be set in this mode.	G
	MODE6	4 min		
	MODE5	3 min		
	MODE4	2 min		
	MODE3*	1 min		
	MODE2	30 sec		
	MODE1	Off		
			H	
			I	

*: Initial Setting

DLK

BCM

< ECU DIAGNOSIS INFORMATION >

ECU DIAGNOSIS INFORMATION

BCM

List of ECU Reference

INFOID:0000000013052204

ECU	Reference
BCM	BCS-32, "Reference Value"
	BCS-51, "Fail Safe"
	BCS-51, "DTC Inspection Priority Chart"
	BCS-52, "DTC Index"

INTELLIGENT KEY SYSTEM

< WIRING DIAGRAM >

-  : WITH Cummins 5.0L AND WITH NAVIGATION WITHOUT BLIND SPOT WARNING SYSTEMS
-  : WITH YK56VD
-  : WITH Cummins 5.0L
-  : WITH REQUEST SWITCH

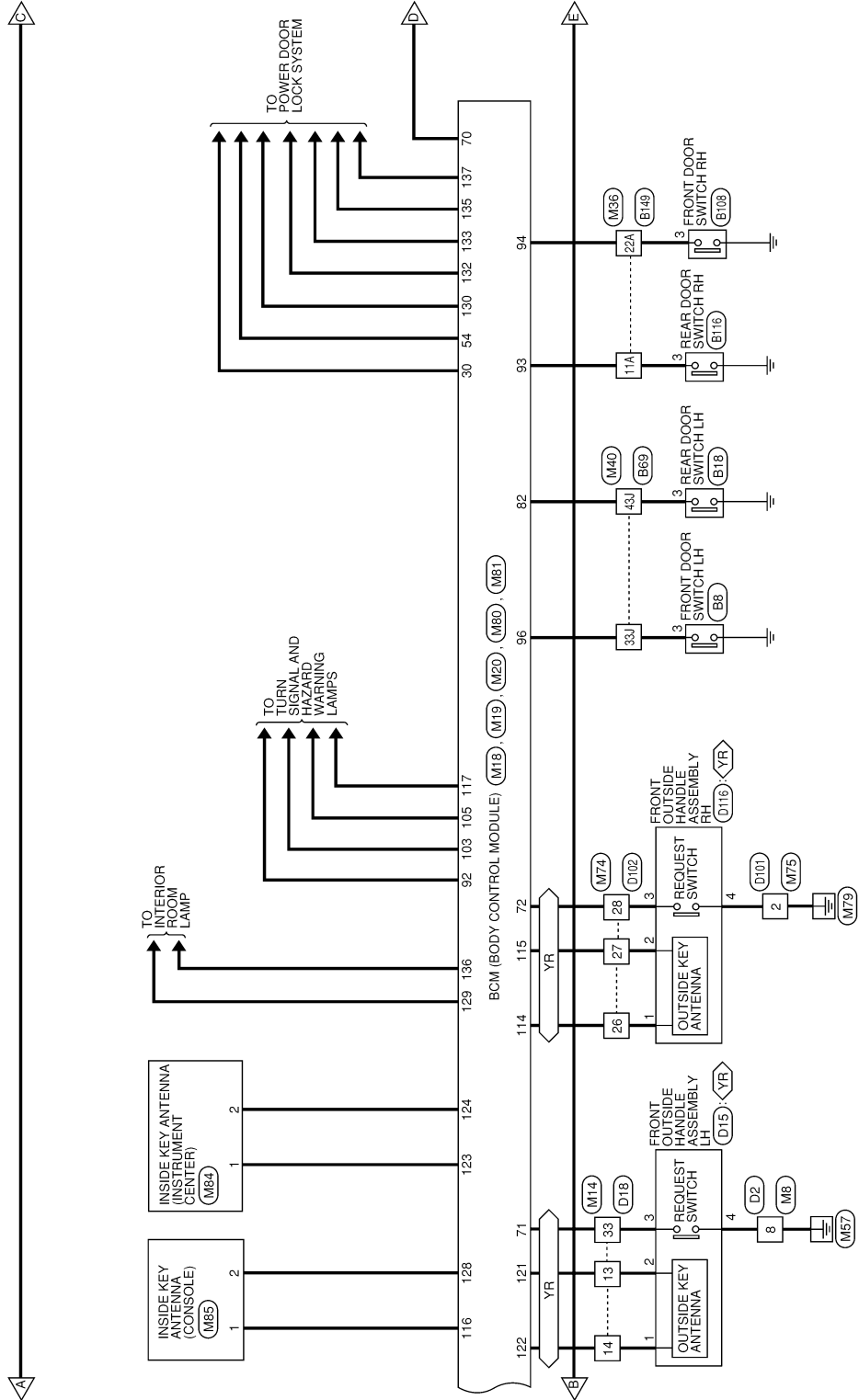

AAKWA1492GB

INTELLIGENT KEY SYSTEM

< WIRING DIAGRAM >

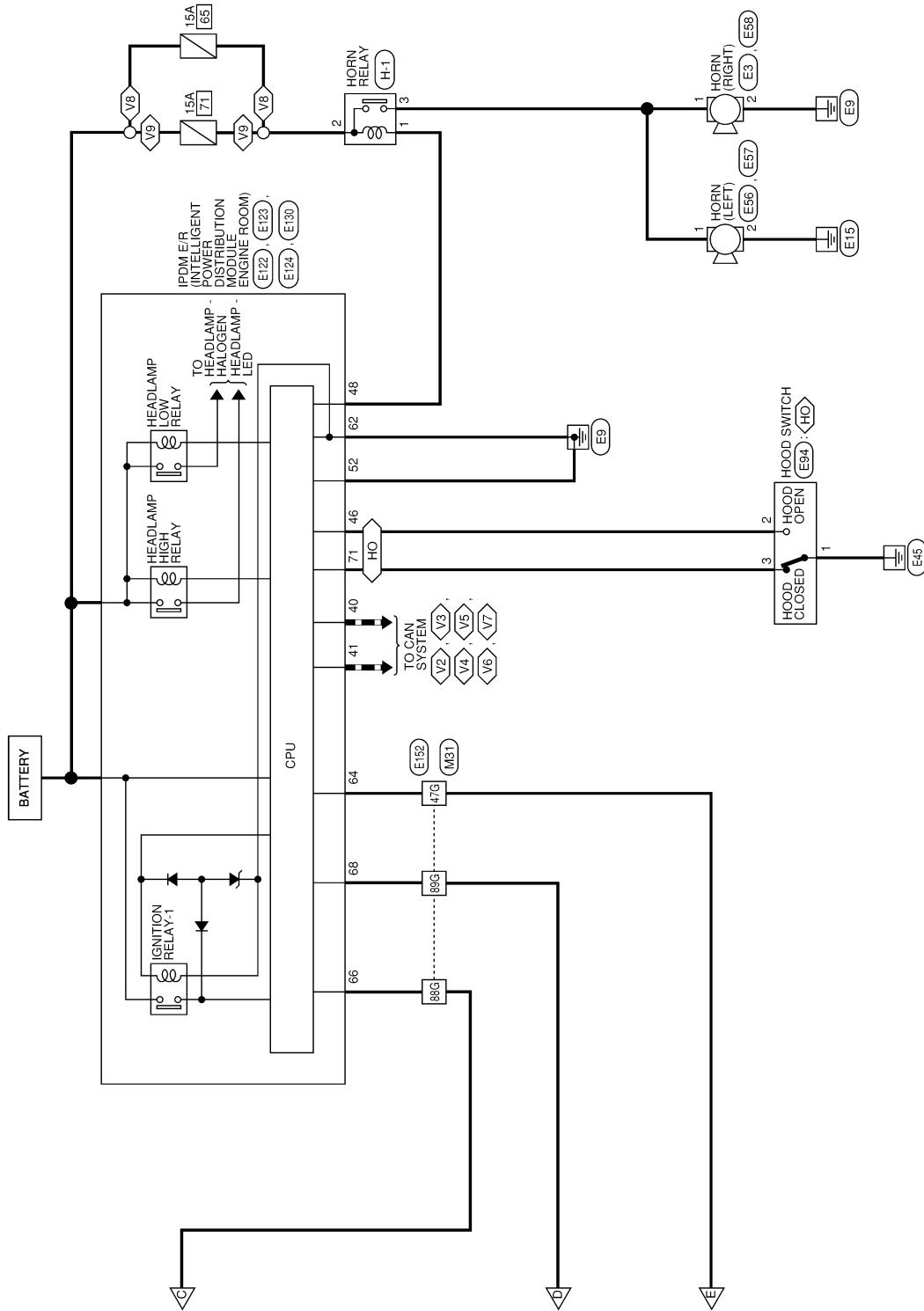

AAKWA1493GB

A
B
C
D
E
F
G
H
I
J
DLK
L
M
N
O
P

INTELLIGENT KEY SYSTEM

< WIRING DIAGRAM >

INTELLIGENT KEY SYSTEM CONNECTORS

Connector No.	B8
Connector Name	FRONT DOOR SWITCH LH
Connector Type	TH04FW-NH
Connector Color	WHITE

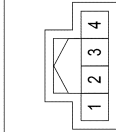

Terminal No.	Color of Wire	Signal Name
1	-	-
2	-	-
3	L	DR DOOR SW
4	-	-

Connector No.	B18
Connector Name	REAR DOOR SWITCH LH
Connector Type	TH04FW-NH
Connector Color	WHITE

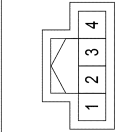

Terminal No.	Color of Wire	Signal Name
1	-	-
2	-	-
3	SB	RL DOOR SW
4	-	-

Connector No.	B69
Connector Name	WIRE TO WIRE
Connector Type	TH00MW-CS16-TM4
Connector Color	WHITE

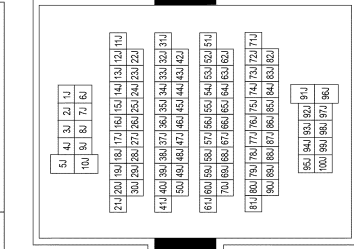

Terminal No.	Color of Wire	Signal Name
1J	P	TO MAIN HARNESS
2J	P/Y	TO MAIN HARNESS
3J	L	TO MAIN HARNESS
4J	L/B	TO MAIN HARNESS
5J	GW	TO MAIN HARNESS
6J	LG/Y	TO MAIN HARNESS
7J	BR/LG	TO MAIN HARNESS
8J	SB/BR	TO MAIN HARNESS
9J	BR	TO MAIN HARNESS
10J	BR	TO MAIN HARNESS
11J	O/B	TO MAIN HARNESS
12J	L	TO MAIN HARNESS
13J	SBO	TO MAIN HARNESS
14J	Y	TO MAIN HARNESS
15J	-	TO MAIN HARNESS
16J	R	TO MAIN HARNESS
17J	G	TO MAIN HARNESS
18J	SB	TO MAIN HARNESS
18J	O	TO MAIN HARNESS
20J	O/B	TO MAIN HARNESS
21J	Y/R	TO MAIN HARNESS
22J	P	TO MAIN HARNESS
23J	W	TO MAIN HARNESS
24J	W/R	TO MAIN HARNESS
25J	V	TO MAIN HARNESS
26J	L	TO MAIN HARNESS
27J	R	TO MAIN HARNESS

28J	L	TO MAIN HARNESS
29J	GW	TO MAIN HARNESS
30J	SB	TO MAIN HARNESS
31J	LG	TO MAIN HARNESS
32J	R	TO MAIN HARNESS
33J	L	TO MAIN HARNESS
34J	Y	TO MAIN HARNESS
35J	P	TO MAIN HARNESS
36J	GR	TO MAIN HARNESS
37J	LG/B	TO MAIN HARNESS
38J	SB	TO MAIN HARNESS
39J	Y/L	TO MAIN HARNESS
40J	BR	TO MAIN HARNESS
41J	L	TO MAIN HARNESS
42J	L	TO MAIN HARNESS
43J	SB	TO MAIN HARNESS
44J	BR	TO MAIN HARNESS
45J	EG	TO MAIN HARNESS
46J	P/Y	TO MAIN HARNESS
47J	Y/GR	TO MAIN HARNESS
48J	V	TO MAIN HARNESS
49J	BR/Y	TO MAIN HARNESS
50J	GW	TO MAIN HARNESS
51J	-	TO MAIN HARNESS
52J	SHIELD	TO MAIN HARNESS
53J	R	TO MAIN HARNESS
54J	L	TO MAIN HARNESS
55J	R	TO MAIN HARNESS
56J	W	TO MAIN HARNESS
57J	L/G	TO MAIN HARNESS
58J	O	TO MAIN HARNESS
59J	-	TO MAIN HARNESS
60J	SHIELD	TO MAIN HARNESS
61J	G	TO MAIN HARNESS
62J	-	TO MAIN HARNESS
63J	R/W	TO MAIN HARNESS
64J	L/W	TO MAIN HARNESS
65J	SHIELD	TO MAIN HARNESS
66J	B	TO MAIN HARNESS
67J	SHIELD	TO MAIN HARNESS
68J	O/L	TO MAIN HARNESS
69J	SHIELD	TO MAIN HARNESS
70J	BR	TO MAIN HARNESS
71J	L/W	TO MAIN HARNESS
72J	-	TO MAIN HARNESS
72J	-	TO MAIN HARNESS
73J	-	TO MAIN HARNESS
74J	SHIELD	TO MAIN HARNESS
75J	LG/B	TO MAIN HARNESS
76J	R	TO MAIN HARNESS
77J	SHIELD	TO MAIN HARNESS
78J	GR/B	TO MAIN HARNESS
79J	B	TO MAIN HARNESS

80J	W	TO MAIN HARNESS
81J	SHIELD	TO MAIN HARNESS
82J	L/R	TO MAIN HARNESS
83J	-	TO MAIN HARNESS
84J	-	TO MAIN HARNESS
85J	Y/B	TO MAIN HARNESS
86J	G	TO MAIN HARNESS
87J	B/R	TO MAIN HARNESS
88J	SHIELD	TO MAIN HARNESS
89J	GR/R	TO MAIN HARNESS
90J	L	TO MAIN HARNESS
91J	L/B	TO MAIN HARNESS
92J	SB	TO MAIN HARNESS
93J	B	TO MAIN HARNESS
94J	L	TO MAIN HARNESS
95J	LG	TO MAIN HARNESS
96J	R	TO MAIN HARNESS
97J	B/Y	TO MAIN HARNESS
98J	L/B	TO MAIN HARNESS
99J	W/L	TO MAIN HARNESS
100J	SB	TO MAIN HARNESS

Connector No.	B108
Connector Name	FRONT DOOR SWITCH RH
Connector Type	TH04FW-NH
Connector Color	WHITE

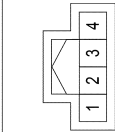

Terminal No.	Color of Wire	Signal Name
1	-	-
2	-	-
3	LGR	AS DOOR SW
4	-	-

INTELLIGENT KEY SYSTEM

< WIRING DIAGRAM >

INTELLIGENT KEY SYSTEM CONNECTORS

Connector No.	B116
Connector Name	REAR DOOR SWITCH RH
Connector Type	TH04FV-NH
Connector Color	WHITE

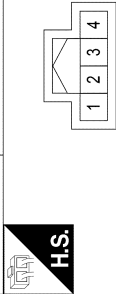

Terminal No.	Color of Wire	Signal Name
1	-	-
2	-	-
3	LG	RR DOOR SW
4	-	-

Connector No.	B149
Connector Name	WIRE TO WIPE
Connector Type	TH80MDGY-CS16-TM4
Connector Color	GRAY

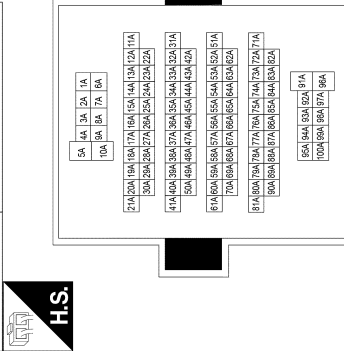

Terminal No.	Color of Wire	Signal Name
1A	SB/G	TO MAIN HARNESS-(WITHOUT CLIMATE CONTROLLED SEATS)
1A	SB	TO MAIN HARNESS (WITH CLIMATE CONTROLLED SEATS)
2A	L	TO MAIN HARNESS
3A	V	TO MAIN HARNESS
4A	SB/R	TO MAIN HARNESS
5A	-	TO MAIN HARNESS

AAKIA3776CB

57A	-	TO MAIN HARNESS
58A	-	TO MAIN HARNESS
59A	-	TO MAIN HARNESS
60A	G/W	TO MAIN HARNESS
61A	-	TO MAIN HARNESS
62A	-	TO MAIN HARNESS
63A	-	TO MAIN HARNESS
64A	-	TO MAIN HARNESS
65A	-	TO MAIN HARNESS
66A	-	TO MAIN HARNESS
67A	-	TO MAIN HARNESS
68A	-	TO MAIN HARNESS
69A	Y/R	TO MAIN HARNESS
70A	R/G	TO MAIN HARNESS
71A	-	TO MAIN HARNESS
72A	Y/B	TO MAIN HARNESS
73A	G	TO MAIN HARNESS
74A	B/R	TO MAIN HARNESS
75A	SHIELD	TO MAIN HARNESS
76A	GR/R	TO MAIN HARNESS
77A	L	TO MAIN HARNESS
78A	SHIELD	TO MAIN HARNESS
79A	Y	TO MAIN HARNESS
80A	L	TO MAIN HARNESS
81A	R	TO MAIN HARNESS
82A	SHIELD	TO MAIN HARNESS
83A	LG/B	TO MAIN HARNESS
84A	R	TO MAIN HARNESS
85A	SHIELD	TO MAIN HARNESS
86A	GR/B	TO MAIN HARNESS
87A	B	TO MAIN HARNESS
88A	W	TO MAIN HARNESS
89A	SHIELD	TO MAIN HARNESS
90A	G	TO MAIN HARNESS
91A	W/L	TO MAIN HARNESS
92A	BR	TO MAIN HARNESS
93A	LY	TO MAIN HARNESS
94A	R/L	TO MAIN HARNESS
95A	BR	TO MAIN HARNESS
96A	R	TO MAIN HARNESS
97A	LG	TO MAIN HARNESS
98A	B/V	TO MAIN HARNESS
99A	O/L	TO MAIN HARNESS
100A	BR/W	TO MAIN HARNESS

Connector No.	D2
Connector Name	WIRE TO WIRE
Connector Type	NS16FW-CS
Connector Color	WHITE

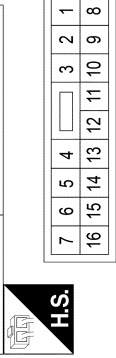

Terminal No.	Color of Wire	Signal Name
1	B/W	TO MAIN HARNESS
2	G/B	TO MAIN HARNESS
3	L	TO MAIN HARNESS
4	R	TO MAIN HARNESS
5	W/R	TO MAIN HARNESS
6	W/L	TO MAIN HARNESS
7	V	TO MAIN HARNESS
8	B	TO MAIN HARNESS
9	L/W	TO MAIN HARNESS
10	L/R	TO MAIN HARNESS
11	L/W	TO MAIN HARNESS
12	L	TO MAIN HARNESS
13	Y	TO MAIN HARNESS
14	SB	TO MAIN HARNESS
15	V	TO MAIN HARNESS
16	LG	TO MAIN HARNESS

Connector No.	D15
Connector Name	FRONT OUTSIDE HANDLE ASSEMBLY LH
Connector Type	RH04FB
Connector Color	BLACK

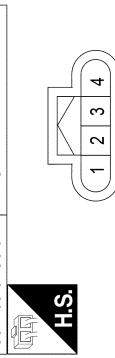

Terminal No.	Color of Wire	Signal Name
1	LG	DOOR ANTENNA A
2	Y	DOOR ANTENNA B
3	BR	DR REQUEST SW
4	B	GROUND

A B C D E F G H I J L M N O P

DLK

INTELLIGENT KEY SYSTEM

< WIRING DIAGRAM >

INTELLIGENT KEY SYSTEM CONNECTORS

Connector No.	D18
Connector Name	WIRE TO WIRE
Connector Type	TH40FW-NH
Connector Color	WHITE

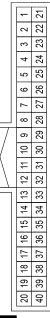

H.S.

Terminal No.	Color of Wire	Signal Name
1	SB	TO MAIN HARNESS -(WITHOUT MEMORY MIRRORS)
1	LG	TO MAIN HARNESS -(WITH AROUND VIEW MONITOR)
2	SB	TO MAIN HARNESS
3	BG	TO MAIN HARNESS
4	Y	TO MAIN HARNESS
5	BR	TO MAIN HARNESS
6	SB	TO MAIN HARNESS
7	V	TO MAIN HARNESS
8	GR	TO MAIN HARNESS
9	L	TO MAIN HARNESS
10	W	TO MAIN HARNESS
11	B	TO MAIN HARNESS
12	R/G	TO MAIN HARNESS
13	Y	TO MAIN HARNESS
14	LG	TO MAIN HARNESS
15	L	TO MAIN HARNESS
16	V	TO MAIN HARNESS
17	LG	TO MAIN HARNESS
18	BR	TO MAIN HARNESS
19	LG/B	TO MAIN HARNESS
20	YW	TO MAIN HARNESS
21	BR	TO MAIN HARNESS -(WITHOUT MEMORY MIRRORS)
21	BG	TO MAIN HARNESS -(WITH MEMORY MIRRORS)
22	V	TO MAIN HARNESS
23	G	TO MAIN HARNESS -(WITHOUT MEMORY MIRRORS)
23	L	TO MAIN HARNESS -(WITH MEMORY MIRRORS)
24	LG	TO MAIN HARNESS
25	Y	TO MAIN HARNESS
26	L	TO MAIN HARNESS
27	Y	TO MAIN HARNESS
28	L	TO MAIN HARNESS
29	V	TO MAIN HARNESS
30	R	TO MAIN HARNESS
31	SHIELD	TO MAIN HARNESS

H.S.

32	R	TO MAIN HARNESS
33	BR	TO MAIN HARNESS
34	-	TO MAIN HARNESS
35	W	TO MAIN HARNESS
36	-	TO MAIN HARNESS
37	-	TO MAIN HARNESS
38	LG	TO MAIN HARNESS
39	SB	TO MAIN HARNESS
40	L	TO MAIN HARNESS



H.S.

Connector No.	D101
Connector Name	WIRE TO WIRE
Connector Type	NS10FW-CS
Connector Color	WHITE

Terminal No.	Color of Wire	Signal Name
1	B/W	TO MAIN HARNESS
2	B	TO MAIN HARNESS
3	W/L	TO MAIN HARNESS
4	V	TO MAIN HARNESS
5	W/B	TO MAIN HARNESS
6	G/Y	TO MAIN HARNESS
7	W/B	TO MAIN HARNESS
8	L/B	TO MAIN HARNESS
9	G/Y	TO MAIN HARNESS
10	-	TO MAIN HARNESS

Connector No.	D102
Connector Name	WIRE TO WIRE
Connector Type	TH32FW-NH
Connector Color	WHITE

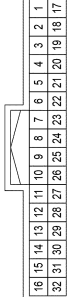

H.S.

Terminal No.	Color of Wire	Signal Name
1	BR	TO MAIN HARNESS
2	V	TO MAIN HARNESS
3	BR	TO MAIN HARNESS

4	L	TO MAIN HARNESS
5	LG/W	TO MAIN HARNESS
6	R/W	TO MAIN HARNESS
7	R/G	TO MAIN HARNESS
8	B	TO MAIN HARNESS
9	W	TO MAIN HARNESS
10	Y	TO MAIN HARNESS
11	LG	TO MAIN HARNESS
12	L	TO MAIN HARNESS
13	Y/V	TO MAIN HARNESS
14	W/L	TO MAIN HARNESS
15	V/R	TO MAIN HARNESS
16	L/W	TO MAIN HARNESS
17	SB	TO MAIN HARNESS
18	Y	TO MAIN HARNESS
19	G	TO MAIN HARNESS
20	V/W	TO MAIN HARNESS -(WITHOUT AUTOMATIC DRIVE POSITIONER)
20	GR/R	TO MAIN HARNESS -(WITH AUTOMATIC DRIVE POSITIONER)
21	-	TO MAIN HARNESS
22	-	TO MAIN HARNESS
23	R	TO MAIN HARNESS
24	R	TO MAIN HARNESS
25	SHIELD	TO MAIN HARNESS
26	LG	TO MAIN HARNESS
27	Y	TO MAIN HARNESS
28	BR	TO MAIN HARNESS
29	LG/B	TO MAIN HARNESS
30	-	TO MAIN HARNESS
31	-	TO MAIN HARNESS
32	-	TO MAIN HARNESS

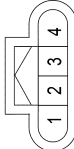

H.S.

Connector No.	D116
Connector Name	FRONT OUTSIDE HANDLE ASSEMBLY RH
Connector Type	RH04FB
Connector Color	BLACK

Terminal No.	Color of Wire	Signal Name
1	LG	DOOR ANTENNA +
2	Y	DOOR ANTENNA -
3	BR	REQUEST SW
4	B	GROUND

Connector No.	E1
Connector Name	INTELLIGENT KEY WARNING BUZZER
Connector Type	RK03FBR
Connector Color	BROWN



H.S.

Terminal No.	Color of Wire	Signal Name
1	G	BATTERY
2	-	-
3	W	BUZZER SIGNAL

Connector No.	E3
Connector Name	HORN (RIGHT)
Connector Type	P01FB-A
Connector Color	BLACK



H.S.

Terminal No.	Color of Wire	Signal Name
1	G	HORN RH

AAKIA3777GB

INTELLIGENT KEY SYSTEM

< WIRING DIAGRAM >

INTELLIGENT KEY SYSTEM CONNECTORS

Connector No.	E12
Connector Name	STOP LAMP RELAY
Connector Type	MS02FL-M2-LC
Connector Color	BLUE



H.S.

Terminal No.	Color of Wire	Signal Name
1	B	GND
2	W	IGNITION
3	R/G	IGNITION
5	R/Y	BATTERY

Connector No.	E38
Connector Name	STOP LAMP SWITCH
Connector Type	M04FW-LC
Connector Color	WHITE



H.S.

Terminal No.	Color of Wire	Signal Name
1	R/Y	BATTERY
2	W	RELAY CONT. - (WITHOUT LED REAR COMBINATION LAMPS)
2	R/G	STOP LAMPS - (WITH LED REAR COMBINATION LAMPS)
3	GR	IGNITION
4	R/B	STOP 2

Connector No.	E56
Connector Name	HORN (LEFT)
Connector Type	P01FB-A
Connector Color	BLACK



H.S.

Terminal No.	Color of Wire	Signal Name
2	B	GND

Connector No.	E57
Connector Name	HORN (LEFT)
Connector Type	P01FB-A
Connector Color	BLACK



H.S.

Terminal No.	Color of Wire	Signal Name
1	G	HORN LH

Connector No.	E58
Connector Name	HORN (RIGHT)
Connector Type	P01FB-A
Connector Color	BLACK



H.S.

Terminal No.	Color of Wire	Signal Name
2	B	GND

Connector No.	E94
Connector Name	HOOD SWITCH
Connector Type	RH03MB
Connector Color	BLACK

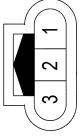

H.S.

Terminal No.	Color of Wire	Signal Name
1	B	GND
2	Y	HOOD SW
3	SB	HOOD SW 2

Connector No.	E122
Connector Name	IPDM E/R (INTELLIGENT POWER DISTRIBUTION MODULE ENGINE ROOM)
Connector Type	TH12FW-NH
Connector Color	WHITE

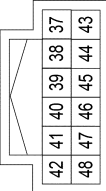

H.S.

Terminal No.	Color of Wire	Signal Name
37	-	-
38	-	-
39	L/Y	WIPER AUTO STOP SW
40	P	CAN-L
41	L	CAN-H
42	BR	DTPL RLY
43	-	-
44	W/B	START CONT
45	GR	FUEL RLY CONT
46	Y	HOOD SW
47	Y	ALT C - (WITH V65WD)
48	R/W	HORN RLY CONT

Connector No.	E123
Connector Name	IPDM E/R (INTELLIGENT POWER DISTRIBUTION MODULE ENGINE ROOM)
Connector Type	NS08FBR-CS
Connector Color	BROWN

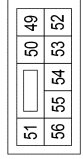

H.S.

Terminal No.	Color of Wire	Signal Name
49	GR/R	A/C COMP. - (WITH V65WD)
49	Y/B	A/C COMP. - (WITH CUMMINS 5.0L)
50	BR	TRAILER TOW
51	-	-
52	B	S-GND
53	-	-
54	-	-
55	-	-
56	-	-

Connector No.	E124
Connector Name	IPDM E/R (INTELLIGENT POWER DISTRIBUTION MODULE ENGINE ROOM)
Connector Type	M06FB-LC
Connector Color	BLACK



H.S.

Terminal No.	Color of Wire	Signal Name
57	W/B	RR DEF
58	BR	FUEL PUMP - (WITH CUMMINS 5.0L)
58	B/Y	FUEL PUMP - (WITH V65WD)
60	-	-
61	-	-
62	B	P GND

A B C D E F G H I J K L M N O P

DLK

AAKIA37786B

INTELLIGENT KEY SYSTEM

< WIRING DIAGRAM >

INTELLIGENT KEY SYSTEM CONNECTORS

Connector No.	E130
Connector Name	IPDM E/R (INTELLIGENT POWER DISTRIBUTION MODULE ENGINE ROOM)
Connector Type	TH10FB-NH
Connector Color	BLACK

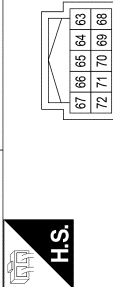

Terminal No.	Color of Wire	Signal Name
63	-	-
64	R	DETENT SW
65	-	-
66	P	PUSH START SW
67	-	-
68	L	IGN SIGNAL
69	-	-
70	-	-
71	SB	HOOD SW2
72	W	E-OPLG - (WITH-VK65VD)

Connector No.	E152
Connector Name	WIRE TO WIRE
Connector Type	TH80MW-CS16-TM4
Connector Color	WHITE

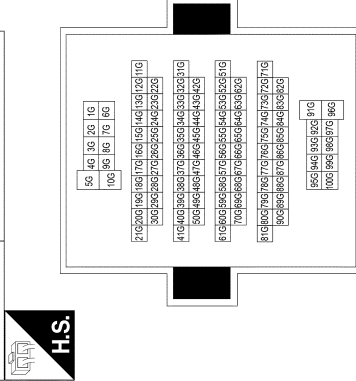

Terminal No.	Color of Wire	Signal Name
1G	G	TO MAIN HARNESS
2G	B/R	TO MAIN HARNESS
3G	W/B	TO MAIN HARNESS
4G	BR/W	TO MAIN HARNESS
5G	BR	TO MAIN HARNESS
6G	P	TO MAIN HARNESS - (WITH-VK65VD)
6G	R/W	TO MAIN HARNESS - (WITH-CUMMINS 5.0L)
7G	Y	TO MAIN HARNESS
8G	G	TO MAIN HARNESS
9G	R	TO MAIN HARNESS
10G	W	TO MAIN HARNESS
11G	R/G	TO MAIN HARNESS
12G	W/B	TO MAIN HARNESS
13G	BR	TO MAIN HARNESS
14G	Y/B	TO MAIN HARNESS
15G	G/W	TO MAIN HARNESS
16G	G	TO MAIN HARNESS
17G	G/Y	TO MAIN HARNESS
18G	G/Y	TO MAIN HARNESS
19G	Y/W	TO MAIN HARNESS
20G	G/Y	TO MAIN HARNESS
21G	B/Y	TO MAIN HARNESS
22G	G/R	TO MAIN HARNESS - (WITH-CUMMINS 5.0L)

70G	L	TO MAIN HARNESS
71G	R/W	TO MAIN HARNESS
72G	L/W	TO MAIN HARNESS
73G	SHIELD	TO MAIN HARNESS
74G	W	TO MAIN HARNESS
75G	R	TO MAIN HARNESS
76G	R/G	TO MAIN HARNESS
77G	G	TO MAIN HARNESS
78G	W	TO MAIN HARNESS
79G	-	TO MAIN HARNESS
80G	R	TO MAIN HARNESS
81G	L	TO MAIN HARNESS
82G	R	TO MAIN HARNESS
83G	L	TO MAIN HARNESS
84G	L	TO MAIN HARNESS
85G	W/B	TO MAIN HARNESS
86G	B/R	TO MAIN HARNESS
87G	W/B	TO MAIN HARNESS
88G	P	TO MAIN HARNESS
89G	L	TO MAIN HARNESS
90G	G	TO MAIN HARNESS
91G	G	TO MAIN HARNESS
92G	W/W	TO MAIN HARNESS
93G	BR	TO MAIN HARNESS
94G	G	TO MAIN HARNESS
95G	G	TO MAIN HARNESS
96G	W	TO MAIN HARNESS
97G	R	TO MAIN HARNESS
98G	W/B	TO MAIN HARNESS
99G	BR	TO MAIN HARNESS
100G	GR/W	TO MAIN HARNESS

22G	G/Y	TO MAIN HARNESS - (WITH-VK65VD)
23G	Y/R	TO MAIN HARNESS
24G	G/B	TO MAIN HARNESS
25G	R/W	TO MAIN HARNESS
26G	R	TO MAIN HARNESS
27G	LG	TO MAIN HARNESS
28G	G/B	TO MAIN HARNESS
29G	G/B	TO MAIN HARNESS
30G	BR/Y	TO MAIN HARNESS
31G	P	TO MAIN HARNESS - (WITH-CUMMINS 5.0L)
31G	R	TO MAIN HARNESS - (WITH-VK65VD)
32G	P	TO MAIN HARNESS
33G	Y/L	TO MAIN HARNESS
34G	GR	TO MAIN HARNESS
35G	G/R	TO MAIN HARNESS
36G	SB	TO MAIN HARNESS
37G	R/W	TO MAIN HARNESS
38G	BR	TO MAIN HARNESS
39G	BR	TO MAIN HARNESS
40G	-	TO MAIN HARNESS
41G	R/G	TO MAIN HARNESS
42G	O	TO MAIN HARNESS
43G	B	TO MAIN HARNESS - (WITH-CUMMINS 5.0L)
43G	G	TO MAIN HARNESS - (WITH-VK65VD)
44G	R/Y	TO MAIN HARNESS
45G	G	TO MAIN HARNESS
46G	LG	TO MAIN HARNESS
47G	R	TO MAIN HARNESS
48G	W	TO MAIN HARNESS
49G	-	TO MAIN HARNESS
50G	BR	TO MAIN HARNESS
51G	R	TO MAIN HARNESS
52G	L	TO MAIN HARNESS
53G	W	TO MAIN HARNESS
54G	W	TO MAIN HARNESS
55G	G	TO MAIN HARNESS
56G	W	TO MAIN HARNESS
57G	Y	TO MAIN HARNESS
58G	BG	TO MAIN HARNESS
59G	BG	TO MAIN HARNESS
60G	BG	TO MAIN HARNESS
61G	B	TO MAIN HARNESS
62G	W	TO MAIN HARNESS
63G	R	TO MAIN HARNESS
64G	W/L	TO MAIN HARNESS
65G	W/R	TO MAIN HARNESS
66G	BG	TO MAIN HARNESS
67G	BG	TO MAIN HARNESS
68G	B	TO MAIN HARNESS
69G	Y	TO MAIN HARNESS

AAKIA37796B

INTELLIGENT KEY SYSTEM

< WIRING DIAGRAM >

INTELLIGENT KEY SYSTEM CONNECTORS

Connector No.	M3
Connector Name	FUSE BLOCK (J/B)
Connector Type	CS06FW-M2
Connector Color	WHITE

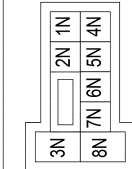

H.S.

Terminal No.	Color of Wire	Signal Name
1N	O	IGN
2N	W	BATTERY
3N	W	IGNITION
4N	V	BATTERY
5N	Y	BATTERY
6N	W	BATTERY
7N	L	ACC RELAY OUT
8N	W	IGNITION

Connector No.	M4
Connector Name	FUSE BLOCK (J/B)
Connector Type	NS16FW-CS
Connector Color	WHITE

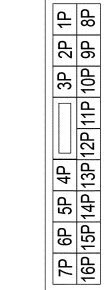

H.S.

Terminal No.	Color of Wire	Signal Name
1P	R	IGNITION
2P	Y	IGNITION
3P	G	IGNITION RELAY OUT
4P	B/W	RR DEF RLY
5P	B/W	RR DEF RLY
6P	O	RR DEF RLY OUT
7P	G	IGNITION
8P	W	IGNITION
9P	L	BATTERY
10P	-	-
11P	-	-
12P	-	-
13P	R	BATTERY
14P	Y	BATTERY
15P	Y/LG	BATTERY

AAKIA3780CB

16P	W	BLOWER FAN RELAY OUT
-----	---	----------------------

Connector No.	M8
Connector Name	WIRE TO WIRE
Connector Type	NS16MW-CS
Connector Color	WHITE

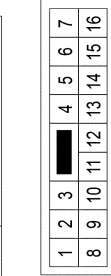

H.S.

Terminal No.	Color of Wire	Signal Name
1	B/W	TO FRONT DOOR LH HARNESS
2	G/B	TO FRONT DOOR LH HARNESS
3	L	TO FRONT DOOR LH HARNESS
4	R	TO FRONT DOOR LH HARNESS
5	W/R	TO FRONT DOOR LH HARNESS
6	W/L	TO FRONT DOOR LH HARNESS
7	V	TO FRONT DOOR LH HARNESS
8	B	TO FRONT DOOR LH HARNESS
9	L/W	TO FRONT DOOR LH HARNESS
10	L/R	TO FRONT DOOR LH HARNESS
11	L/W	TO FRONT DOOR LH HARNESS
12	L	TO FRONT DOOR LH HARNESS
13	Y	TO FRONT DOOR LH HARNESS
14	SB	TO FRONT DOOR LH HARNESS
15	V	TO FRONT DOOR LH HARNESS
16	LG	TO FRONT DOOR LH HARNESS

Connector No.	M14
Connector Name	WIRE TO WIRE
Connector Type	TH40MW-NH
Connector Color	WHITE

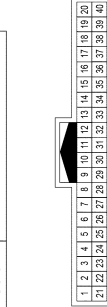

H.S.

Terminal No.	Color of Wire	Signal Name
1	LG	TO FRONT DOOR LH HARNESS - (WITH MEMORY MIRRORS)
1	SB	TO FRONT DOOR LH HARNESS - (WITHOUT MEMORY MIRRORS)
2	SB	TO FRONT DOOR LH HARNESS
3	B	TO FRONT DOOR LH HARNESS

4	Y	TO FRONT DOOR LH HARNESS
5	V	TO FRONT DOOR LH HARNESS
6	SB	TO FRONT DOOR LH HARNESS
7	Y	TO FRONT DOOR LH HARNESS
8	GR	TO FRONT DOOR LH HARNESS
9	L	TO FRONT DOOR LH HARNESS
10	W	TO FRONT DOOR LH HARNESS
11	B	TO FRONT DOOR LH HARNESS
12	R/G	TO FRONT DOOR LH HARNESS
13	G	TO FRONT DOOR LH HARNESS
14	P	TO FRONT DOOR LH HARNESS
15	O	TO FRONT DOOR LH HARNESS
16	V	TO FRONT DOOR LH HARNESS
17	P	TO FRONT DOOR LH HARNESS
18	G	TO FRONT DOOR LH HARNESS
19	LG/B	TO FRONT DOOR LH HARNESS
20	Y/V	TO FRONT DOOR LH HARNESS
21	O	TO FRONT DOOR LH HARNESS - (WITH MEMORY MIRRORS)
21	BR	TO FRONT DOOR LH HARNESS - (WITHOUT MEMORY MIRRORS)
22	BG	TO FRONT DOOR LH HARNESS
23	L	TO FRONT DOOR LH HARNESS - (WITH MEMORY MIRRORS)
23	G	TO FRONT DOOR LH HARNESS - (WITHOUT MEMORY MIRRORS)
24	BR	TO FRONT DOOR LH HARNESS
25	Y	TO FRONT DOOR LH HARNESS
26	LG	TO FRONT DOOR LH HARNESS
27	W	TO FRONT DOOR LH HARNESS
28	L	TO FRONT DOOR LH HARNESS
29	P	TO FRONT DOOR LH HARNESS
30	R	TO FRONT DOOR LH HARNESS
31	SHIELD	TO FRONT DOOR LH HARNESS
32	R	TO FRONT DOOR LH HARNESS
33	O	TO FRONT DOOR LH HARNESS
34	-	TO FRONT DOOR LH HARNESS
35	W	TO FRONT DOOR LH HARNESS
36	-	TO FRONT DOOR LH HARNESS
37	-	TO FRONT DOOR LH HARNESS
38	GR	TO FRONT DOOR LH HARNESS
39	P	TO FRONT DOOR LH HARNESS
40	R	TO FRONT DOOR LH HARNESS

A
B
C
D
E
F
G
H
I
J
K
L
M
N
O
P

DLK

INTELLIGENT KEY SYSTEM CONNECTORS

Connector No.	M18
Connector Name	BCM (BODY CONTROL MODULE)
Connector Type	TH40FG-NH
Connector Color	GREEN

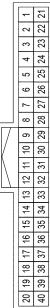

Terminal No.	Color of Wire	Signal Name
1	G	ENG START SW NO ESCL
2	--	--
3	R	ALL POWER SUPPLY SV
4	W/R	AL SIGNAL
5	--	--
6	--	--
7	--	--
8	--	--
9	--	--
10	SB	COMBI SW IN 5
11	G/Y	COMBI SW IN 4
12	Y	COMBI SW IN 3
13	G/B	COMBI SW IN 2
14	V	COMBI SW IN 1
15	--	--
16	--	--
17	P	GND RF AL
18	V	SECURITY INDICATOR
19	--	--
20	R	SHIFT P
21	R/W	STEP LAMP CONT
22	--	--
23	Y	AIRCON SW
24	--	--
25	W	BRAKE SW FUSE
26	L	SHORT IN PIN INPUT
27	P/G	BRAKE SW LAMP
28	--	--
29	W	BLOWER FAN SW
30	P	DR DOOR LOCK STATUS
31	--	--
32	Y	REAR DEFOGGER SW
33	--	--
34	--	--
35	P/G	REVERSE SW
36	W/B	HAZARD SW
37	--	--
38	--	--

39	B/R	SHIFT N/P
40	--	--

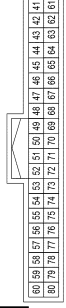
Terminal No.	Color of Wire	Signal Name
41	Y/L	TRAILER LIGHT CHECK RELAY OUT
42	R/Y	CARGO LAMP OUT
43	--	--
44	--	--
45	--	--
46	--	--
47	--	--
48	R	HIGH SIDE START SW LED
49	--	--
50	--	--
51	--	--
52	W	AUDIO DONGLE
53	--	--
54	W/L	PW UART
55	W/B	LAR SENSOR K-LINE
56	--	--
57	--	--
58	--	--
59	P	CAN-L
60	L	CAN-H
61	O	REAR DEFOGGER RELAY OUT
62	W	STARTER RELAY OUT
63	--	--
64	P	BUZZER OUT
65	--	--
66	W	BLOWER FAN RELAY OUT
67	G	IGN ELEC RELAY OUT 2
68	L	MP OUTPUT
69	R/B	AT DEVICE OUT
70	P	IGN USM OUT 1
71	O	DR REQUEST SW
72	G	AS REQUEST SW
73	--	--
74	--	--

75	L/W	COMBI SW OUT 5
76	P	COMBI SW OUT 4
77	L	COMBI SW OUT 3
78	O/B	COMBI SW OUT 2
79	R/W	COMBI SW OUT 1
80	--	--

Terminal No.	Color of Wire	Signal Name
81	--	--
82	W	RL DOOR SW
83	--	--
84	--	--
85	G/B	TRAILER FLASHER RL
87	Y/B	TRAILER FLASHER RR
88	--	--
89	--	--
90	--	--
91	O	RR FLASHER
92	O	RR DOOR SW
93	R	AS DOOR SW
94	G	--
95	--	--
96	B/G	DR DOOR SW
97	P/L	CARGO LAMP SW
98	--	--
99	--	--
100	--	--
101	--	--
102	--	--
103	G/B	RL FLASHER
104	--	--

AAKIA3781GB

INTELLIGENT KEY SYSTEM

< WIRING DIAGRAM >

INTELLIGENT KEY SYSTEM CONNECTORS

Connector No.	M31
Connector Name	WIRE TO WIRE
Connector Type	TH80FW-CS16-TM4
Connector Color	WHITE

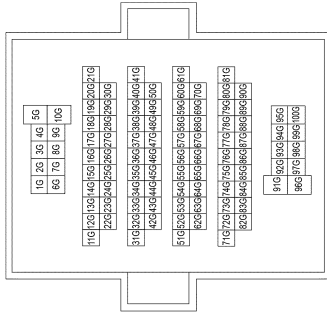

Terminal No.	Color of Wire	Signal Name
1G	G	TO ENGINE ROOM HARNESS
2G	B/R	TO ENGINE ROOM HARNESS
3G	W	TO ENGINE ROOM HARNESS
4G	B/W	TO ENGINE ROOM HARNESS
5G	BR	TO ENGINE ROOM HARNESS
6G	R/W	TO ENGINE ROOM HARNESS
7G	Y	TO ENGINE ROOM HARNESS
8G	G	TO ENGINE ROOM HARNESS
9G	R	TO ENGINE ROOM HARNESS
10G	W	TO ENGINE ROOM HARNESS
11G	P/G	TO ENGINE ROOM HARNESS
12G	W/B	TO ENGINE ROOM HARNESS
13G	BR	TO ENGINE ROOM HARNESS
14G	Y/B	TO ENGINE ROOM HARNESS
15G	G/W	TO ENGINE ROOM HARNESS
16G	G	TO ENGINE ROOM HARNESS
17G	O	TO ENGINE ROOM HARNESS
18G	G/Y	TO ENGINE ROOM HARNESS
19G	Y/W	TO ENGINE ROOM HARNESS
20G	G/Y	TO ENGINE ROOM HARNESS
21G	B/Y	TO ENGINE ROOM HARNESS
22G	G/R	TO ENGINE ROOM HARNESS - (WITH CUMMINS 5.0L)
22G	G/Y	TO ENGINE ROOM HARNESS - (WITH VK56/D)
23G	Y/R	TO ENGINE ROOM HARNESS
24G	G/B	TO ENGINE ROOM HARNESS

AAKIA3782GB

76G	P	TO ENGINE ROOM HARNESS
76G	-	TO ENGINE ROOM HARNESS
80G	R	TO ENGINE ROOM HARNESS
81G	L	TO ENGINE ROOM HARNESS
82G	R	TO ENGINE ROOM HARNESS
83G	L	TO ENGINE ROOM HARNESS
84G	L	TO ENGINE ROOM HARNESS
86G	W	TO ENGINE ROOM HARNESS
86G	B/R	TO ENGINE ROOM HARNESS
87G	W	TO ENGINE ROOM HARNESS
88G	G	TO ENGINE ROOM HARNESS
89G	P	TO ENGINE ROOM HARNESS
90G	G	TO ENGINE ROOM HARNESS
91G	P	TO ENGINE ROOM HARNESS
92G	V/W	TO ENGINE ROOM HARNESS
93G	BR	TO ENGINE ROOM HARNESS
94G	B	TO ENGINE ROOM HARNESS
95G	G	TO ENGINE ROOM HARNESS
96G	R	TO ENGINE ROOM HARNESS
97G	R	TO ENGINE ROOM HARNESS
98G	W/B	TO ENGINE ROOM HARNESS
99G	R	TO ENGINE ROOM HARNESS
100G	GRW	TO ENGINE ROOM HARNESS

25G	R/W	TO ENGINE ROOM HARNESS
26G	R	TO ENGINE ROOM HARNESS
27G	LG	TO ENGINE ROOM HARNESS
28G	G/B	TO ENGINE ROOM HARNESS
29G	G/B	TO ENGINE ROOM HARNESS
30G	B/Y	TO ENGINE ROOM HARNESS
31G	R	TO ENGINE ROOM HARNESS
32G	R	TO ENGINE ROOM HARNESS
33G	Y/L	TO ENGINE ROOM HARNESS
34G	GR	TO ENGINE ROOM HARNESS
35G	G/R	TO ENGINE ROOM HARNESS
36G	SB	TO ENGINE ROOM HARNESS
37G	R/W	TO ENGINE ROOM HARNESS
38G	BR	TO ENGINE ROOM HARNESS
38G	BR	TO ENGINE ROOM HARNESS
40G	-	TO ENGINE ROOM HARNESS
41G	R/G	TO ENGINE ROOM HARNESS
42G	O	TO ENGINE ROOM HARNESS
44G	P/Y	TO ENGINE ROOM HARNESS
45G	G	TO ENGINE ROOM HARNESS
46G	LG	TO ENGINE ROOM HARNESS
47G	R	TO ENGINE ROOM HARNESS
48G	W	TO ENGINE ROOM HARNESS
49G	-	TO ENGINE ROOM HARNESS
50G	BR	TO ENGINE ROOM HARNESS
51G	R	TO ENGINE ROOM HARNESS
52G	L	TO ENGINE ROOM HARNESS
53G	W	TO ENGINE ROOM HARNESS
54G	W	TO ENGINE ROOM HARNESS
55G	G	TO ENGINE ROOM HARNESS
56G	W	TO ENGINE ROOM HARNESS
57G	Y	TO ENGINE ROOM HARNESS
58G	BG	TO ENGINE ROOM HARNESS
59G	BG	TO ENGINE ROOM HARNESS
60G	BG	TO ENGINE ROOM HARNESS
61G	O	TO ENGINE ROOM HARNESS
62G	W	TO ENGINE ROOM HARNESS
63G	O	TO ENGINE ROOM HARNESS
64G	W/L	TO ENGINE ROOM HARNESS
65G	W/R	TO ENGINE ROOM HARNESS
66G	BG	TO ENGINE ROOM HARNESS
67G	O	TO ENGINE ROOM HARNESS
68G	B	TO ENGINE ROOM HARNESS
69G	Y	TO ENGINE ROOM HARNESS
70G	L	TO ENGINE ROOM HARNESS
71G	R/W	TO ENGINE ROOM HARNESS
72G	L/W	TO ENGINE ROOM HARNESS
73G	SHIELD	TO ENGINE ROOM HARNESS
74G	W	TO ENGINE ROOM HARNESS
75G	R	TO ENGINE ROOM HARNESS
76G	R/G	TO ENGINE ROOM HARNESS
77G	BG	TO ENGINE ROOM HARNESS

A
B
C
D
E
F
G
H
I
J
K
L
M
N
O
P

DLK

INTELLIGENT KEY SYSTEM

< WIRING DIAGRAM >

INTELLIGENT KEY SYSTEM CONNECTORS

Connector No.	M36
Connector Name	WIRE TO WIRE
Connector Type	TH80FDGY-CST6-TM4
Connector Color	GRAY

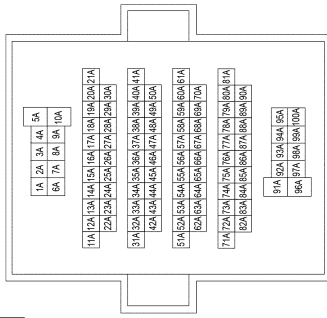

76A	SHIELD	TO BODY NO. 2 HARNESS
76A	R	TO BODY NO. 2 HARNESS
77A	L	TO BODY NO. 2 HARNESS
78A	SHIELD	TO BODY NO. 2 HARNESS
79A	GR	TO BODY NO. 2 HARNESS
80A	V	TO BODY NO. 2 HARNESS
81A	R	TO BODY NO. 2 HARNESS
82A	SHIELD	TO BODY NO. 2 HARNESS
83A	R	TO BODY NO. 2 HARNESS
84A	O	TO BODY NO. 2 HARNESS
85A	SHIELD	TO BODY NO. 2 HARNESS
86A	W	TO BODY NO. 2 HARNESS
87A	B	TO BODY NO. 2 HARNESS
88A	W	TO BODY NO. 2 HARNESS
89A	SHIELD	TO BODY NO. 2 HARNESS
90A	G	TO BODY NO. 2 HARNESS
91A	W/L	TO BODY NO. 2 HARNESS
92A	BR	TO BODY NO. 2 HARNESS
93A	L/Y	TO BODY NO. 2 HARNESS
94A	R/L	TO BODY NO. 2 HARNESS
95A	BR	TO BODY NO. 2 HARNESS
96A	R	TO BODY NO. 2 HARNESS
97A	LG	TO BODY NO. 2 HARNESS
98A	B/V	TO BODY NO. 2 HARNESS
99A	O/V	TO BODY NO. 2 HARNESS
100A	BR/W	TO BODY NO. 2 HARNESS

22A	G	TO BODY NO. 2 HARNESS
23A	Y	TO BODY NO. 2 HARNESS
24A	L	TO BODY NO. 2 HARNESS
25A	-	TO BODY NO. 2 HARNESS
26A	GR	TO BODY NO. 2 HARNESS
27A	LG	TO BODY NO. 2 HARNESS
28A	LG	TO BODY NO. 2 HARNESS
29A	GR	TO BODY NO. 2 HARNESS
30A	-	TO BODY NO. 2 HARNESS
31A	W/R	TO BODY NO. 2 HARNESS
32A	G/R	TO BODY NO. 2 HARNESS
33A	-	TO BODY NO. 2 HARNESS
34A	SHIELD	TO BODY NO. 2 HARNESS
35A	P	TO BODY NO. 2 HARNESS
36A	B	TO BODY NO. 2 HARNESS
37A	-	TO BODY NO. 2 HARNESS
38A	R/B	TO BODY NO. 2 HARNESS
39A	G/O	TO BODY NO. 2 HARNESS
40A	V	TO BODY NO. 2 HARNESS
41A	SHIELD	TO BODY NO. 2 HARNESS
42A	SHIELD	TO BODY NO. 2 HARNESS
43A	R	TO BODY NO. 2 HARNESS
44A	G	TO BODY NO. 2 HARNESS
45A	-	TO BODY NO. 2 HARNESS
46A	-	TO BODY NO. 2 HARNESS
47A	Y	TO BODY NO. 2 HARNESS
48A	R/W	TO BODY NO. 2 HARNESS
49A	R/L	TO BODY NO. 2 HARNESS
50A	B	TO BODY NO. 2 HARNESS
51A	-	TO BODY NO. 2 HARNESS
52A	-	TO BODY NO. 2 HARNESS
53A	-	TO BODY NO. 2 HARNESS
54A	-	TO BODY NO. 2 HARNESS
55A	-	TO BODY NO. 2 HARNESS
56A	-	TO BODY NO. 2 HARNESS
57A	-	TO BODY NO. 2 HARNESS
58A	-	TO BODY NO. 2 HARNESS
59A	-	TO BODY NO. 2 HARNESS
60A	G/W	TO BODY NO. 2 HARNESS
61A	-	TO BODY NO. 2 HARNESS
62A	-	TO BODY NO. 2 HARNESS
63A	-	TO BODY NO. 2 HARNESS
64A	-	TO BODY NO. 2 HARNESS
65A	-	TO BODY NO. 2 HARNESS
66A	-	TO BODY NO. 2 HARNESS
67A	-	TO BODY NO. 2 HARNESS
68A	Y/R	TO BODY NO. 2 HARNESS
69A	R/G	TO BODY NO. 2 HARNESS
70A	-	TO BODY NO. 2 HARNESS
71A	-	TO BODY NO. 2 HARNESS
72A	W	TO BODY NO. 2 HARNESS
73A	G	TO BODY NO. 2 HARNESS
74A	W	TO BODY NO. 2 HARNESS

Terminal No.	Color of Wire	Signal Name
1A	W	TO BODY NO. 2 HARNESS
2A	LG	TO BODY NO. 2 HARNESS
3A	V	TO BODY NO. 2 HARNESS
4A	SB	TO BODY NO. 2 HARNESS
5A	-	TO BODY NO. 2 HARNESS
6A	BG	TO BODY NO. 2 HARNESS - (WITH CLIMATE CONTROLLED SEAT)
6A	LG	TO BODY NO. 2 HARNESS - (WITHOUT CLIMATE CONTROLLED SEAT)
7A	W	TO BODY NO. 2 HARNESS
8A	B	TO BODY NO. 2 HARNESS
9A	L/B	TO BODY NO. 2 HARNESS
10A	W	TO BODY NO. 2 HARNESS
11A	R	TO BODY NO. 2 HARNESS
12A	BR	TO BODY NO. 2 HARNESS
13A	G	TO BODY NO. 2 HARNESS
14A	P/G	TO BODY NO. 2 HARNESS
15A	O	TO BODY NO. 2 HARNESS
16A	O/L	TO BODY NO. 2 HARNESS
17A	L	TO BODY NO. 2 HARNESS
18A	Y	TO BODY NO. 2 HARNESS
19A	B/W	TO BODY NO. 2 HARNESS
20A	BR/Y	TO BODY NO. 2 HARNESS
21A	BG	TO BODY NO. 2 HARNESS

AAKIA3783GB

INTELLIGENT KEY SYSTEM

< WIRING DIAGRAM >

INTELLIGENT KEY SYSTEM CONNECTORS

Connector No.	M40
Connector Name	WIRE TO WIRE
Connector Type	TH80FW-CS16-TM4
Connector Color	WHITE

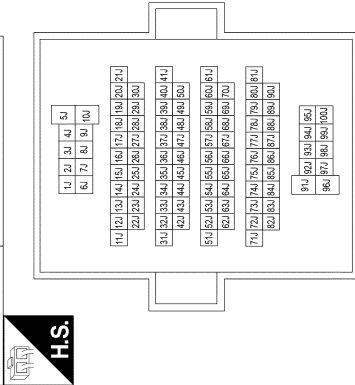

28J	L	TO BODY HARNESS
29J	G/O	TO BODY HARNESS
30J	SB	TO BODY HARNESS
31J	L/G	TO BODY HARNESS
32J	R	TO BODY HARNESS
33J	BG	TO BODY HARNESS
34J	Y	TO BODY HARNESS
35J	P	TO BODY HARNESS
36J	G/R	TO BODY HARNESS
37J	LG	TO BODY HARNESS
38J	SB	TO BODY HARNESS
39J	Y	TO BODY HARNESS
40J	SB	TO BODY HARNESS
41J	L	TO BODY HARNESS
42J	L	TO BODY HARNESS
43J	W	TO BODY HARNESS
44J	BR	TO BODY HARNESS
45J	BG	TO BODY HARNESS
46J	P	TO BODY HARNESS
47J	O	TO BODY HARNESS
48J	V	TO BODY HARNESS
49J	BR	TO BODY HARNESS
50J	G/W	TO BODY HARNESS
51J	-	TO BODY HARNESS
52J	SHIELD	TO BODY HARNESS
53J	R	TO BODY HARNESS
54J	L	TO BODY HARNESS
55J	R	TO BODY HARNESS
56J	W	TO BODY HARNESS
57J	R	TO BODY HARNESS
58J	B	TO BODY HARNESS
59J	-	TO BODY HARNESS
60J	SHIELD	TO BODY HARNESS
61J	G	TO BODY HARNESS
62J	-	TO BODY HARNESS
63J	R/W	TO BODY HARNESS
64J	L/W	TO BODY HARNESS
65J	SHIELD	TO BODY HARNESS
66J	B	TO BODY HARNESS
67J	SHIELD	TO BODY HARNESS
68J	W	TO BODY HARNESS
69J	SHIELD	TO BODY HARNESS
70J	B/R	TO BODY HARNESS
71J	L/W	TO BODY HARNESS
72J	-	TO BODY HARNESS
73J	-	TO BODY HARNESS
74J	SHIELD	TO BODY HARNESS
75J	R	TO BODY HARNESS
76J	O	TO BODY HARNESS
77J	SHIELD	TO BODY HARNESS
78J	W	TO BODY HARNESS
79J	B	TO BODY HARNESS
80J	W	TO BODY HARNESS

Connector No.	M68
Connector Name	A/T SHIFT SELECTOR
Connector Type	TK08FW
Connector Color	WHITE

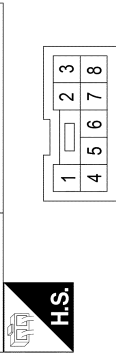

Terminal No.	Color of Wire	Signal Name
1	B	GND
2	B	GND
3	L/R	SHIFT LOCK SOL OUT
4	R	SHIFT P
5	R/B	AT DEVICE OUT
6	LG	TOW MODE SW
7	BR	SHIFT UP
8	V/W	SHIFT DOWN

Terminal No.	Color of Wire	Signal Name
1J	G	TO BODY HARNESS
2J	R/Y	TO BODY HARNESS
3J	L	TO BODY HARNESS
4J	L/B	TO BODY HARNESS
5J	B	TO BODY HARNESS
6J	BR	TO BODY HARNESS
7J	BG	TO BODY HARNESS
8J	SB	TO BODY HARNESS
9J	BR	TO BODY HARNESS
10J	R	TO BODY HARNESS
11J	O/B	TO BODY HARNESS
12J	L	TO BODY HARNESS
13J	W	TO BODY HARNESS
14J	Y	TO BODY HARNESS
15J	-	TO BODY HARNESS
16J	R	TO BODY HARNESS
17J	G	TO BODY HARNESS
18J	SB	TO BODY HARNESS
19J	O	TO BODY HARNESS
20J	O/B	TO BODY HARNESS
21J	Y	TO BODY HARNESS
22J	P	TO BODY HARNESS
23J	W	TO BODY HARNESS
24J	W/R	TO BODY HARNESS
25J	P	TO BODY HARNESS
26J	L	TO BODY HARNESS
27J	R	TO BODY HARNESS

AAKIA3784GB

Connector No.	M46
Connector Name	PUSH-BUTTON IGNITION SWITCH
Connector Type	TH08FW-NH
Connector Color	WHITE

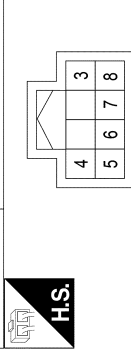

Terminal No.	Color of Wire	Signal Name
3	BG	BATTERY
4	B	GND
5	R	HIGH SIDE START SW LED
6	W	ILLUMINATION -
7	P	ACC LED
8	G	ENG START SW NO ESCL

Connector No.	M69
Connector Name	FUSE BLOCK (J/B)
Connector Type	NS10FW-CS
Connector Color	WHITE

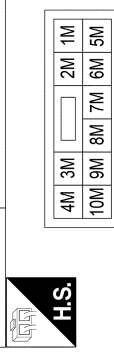

Terminal No.	Color of Wire	Signal Name
1M	GR	IGNITION
2M	-	-
3M	-	-
4M	-	-
5M	R/Y	BATTERY
6M	R/W	TAIL LAMP 2
7M	-	-
8M	-	-
9M	-	-
10M	W/R	IGNITION

A B C D E F G H I J K L M N O P

DLK

INTELLIGENT KEY SYSTEM

< WIRING DIAGRAM >

INTELLIGENT KEY SYSTEM CONNECTORS

Connector No.	M70
Connector Name	FUSE BLOCK (J/B)
Connector Type	NS16FBR-CS
Connector Color	BROWN



7R	6R	5R	4R	3R	2R	1R
16R	15R	14R	13R	12R	11R	10R
9R	8R					

Terminal No.	Color of Wire	Signal Name
1R	L	TAIL LAMP 2
2R	G/R	IGNITION
3R	Y/R	BATTERY
4R	-	-
5R	W	BATTERY
6R	G/W	ACCESSORY
7R	R	BATTERY
8R	-	-
9R	-	-
10R	W	BATTERY
11R	-	-
12R	B/G	BATTERY
13R	B	ACCESSORY
14R	G/Y	BATTERY
15R	Y	BATTERY
16R	G/R	ACCESSORY



1	2	3	4	5	6	7	8	9	10	11	12	13	14	15	16
17	18	19	20	21	22	23	24	25	26	27	28	29	30	31	32

Connector No.	M74
Connector Name	WIRE TO WIRE
Connector Type	TH32MM-NH
Connector Color	WHITE

Terminal No.	Color of Wire	Signal Name
8	B	TO FRONT DOOR RH HARNESS
9	W	TO FRONT DOOR RH HARNESS
10	Y	TO FRONT DOOR RH HARNESS
11	LG	TO FRONT DOOR RH HARNESS
12	L	TO FRONT DOOR RH HARNESS
13	Y/V	TO FRONT DOOR RH HARNESS
14	W/L	TO FRONT DOOR RH HARNESS
15	V/R	TO FRONT DOOR RH HARNESS
16	L/W	TO FRONT DOOR RH HARNESS
17	SB	TO FRONT DOOR RH HARNESS
18	Y	TO FRONT DOOR RH HARNESS
19	G	TO FRONT DOOR RH HARNESS
20	V/W	TO FRONT DOOR RH HARNESS - (WITHOUT AUTOMATIC DRIVE POSITIONER)
20	GR/R	TO FRONT DOOR RH HARNESS - (WITH POSITIONER)
21	-	TO FRONT DOOR RH HARNESS
22	-	TO FRONT DOOR RH HARNESS
23	O	TO FRONT DOOR RH HARNESS
24	R	TO FRONT DOOR RH HARNESS
25	SHIELD	TO FRONT DOOR RH HARNESS
26	W	TO FRONT DOOR RH HARNESS
27	B/G	TO FRONT DOOR RH HARNESS
28	G	TO FRONT DOOR RH HARNESS
29	Lg/B	TO FRONT DOOR RH HARNESS
30	-	TO FRONT DOOR RH HARNESS
31	-	TO FRONT DOOR RH HARNESS
32	-	TO FRONT DOOR RH HARNESS

1	2	3	4
5	6	7	8
9	10		

Connector No.	M75
Connector Name	WIRE TO WIRE
Connector Type	NS10MW-CS
Connector Color	WHITE



Terminal No.	Color of Wire	Signal Name
1	B/W	TO FRONT DOOR RH HARNESS
2	B	TO FRONT DOOR RH HARNESS
3	W/L	TO FRONT DOOR RH HARNESS
4	V	TO FRONT DOOR RH HARNESS
5	W/B	TO FRONT DOOR RH HARNESS
6	G/Y	TO FRONT DOOR RH HARNESS
7	W/B	TO FRONT DOOR RH HARNESS
8	L/B	TO FRONT DOOR RH HARNESS
9	G/Y	TO FRONT DOOR RH HARNESS

10	-	TO FRONT DOOR RH HARNESS
----	---	--------------------------



116	115	114	113	112	111	110	109	108	107	106	105
128	127	126	125	124	123	122	121	120	119	118	117

Terminal No.	Color of Wire	Signal Name
105	G/Y	FR FLASHER
106	-	-
107	W	LOW SIDE START SW LED
108	L/R	SHIFT LOCK SOLENOID OUT
109	-	-
110	P	ACC LED
111	-	-
112	-	-
113	L	ACC RELAY OUT
114	W	AS DOOR ANT A
115	B/G	AS DOOR ANT B
116	W	ROOM ANT 2 A
117	G/B	FL FLASHER
118	-	-
119	R	RF MIMOCO
120	-	-
121	G	DR DOOR ANT B
122	P	DR DOOR ANT A
123	W	ROOM ANT 1 A
124	G	ROOM ANT 1 B
125	-	-
126	P	IMMO START BUTTON ANT B
127	B/G	IMMO START BUTTON ANT A
128	B	ROOM ANT 2 B

Connector No.	M81
Connector Name	BCM (BODY CONTROL MODULE)
Connector Type	FEA09FW-FHAG-SA
Connector Color	WHITE



137	136	135	134	133	132	131	130	129
143	142	141	140	139	138			

Terminal No.	Color of Wire	Signal Name
129	R/G	BATTERY SAVER OUT
130	LG	SUPER LOCK/DOOR UNLOCK AS
131	W	BAT BDM FUSE
132	Y	DOOR LOCK AS/RR/L
133	BR	DOOR UNLOCK AS/RR/L
134	B	GN2
135	O	DOOR LOCK DR/AS/FL
136	L	ROOM LAMP CONT
137	V	DOOR UNLOCK DR/AS/FL
138	V	BAT REAR DOOR
139	W	BAT-POWER FL
140	LG	P/W POWER SUPPLY IGN
141	V	P/W POWER SUPPLY BAT
142	Y	BAT FRONT DOOR
143	B	GN01



Connector No.	M84
Connector Name	INSIDE KEY ANTENNA (INSTRUMENT CENTER)
Connector Type	RK02FGY
Connector Color	GRAY

Terminal No.	Color of Wire	Signal Name
1	W	ROOM ANT 1A
2	G	ROOM ANT 1B

AAKIA3785GB

INTELLIGENT KEY SYSTEM

< WIRING DIAGRAM >

INTELLIGENT KEY SYSTEM CONNECTORS

Connector No.	M85
Connector Name	INSIDE KEY ANTENNA (CONSOLLE)
Connector Type	RK02FGY
Connector Color	GRAY



Terminal No.	Color of Wire	Signal Name
1	W	ROOM ANT 2A
2	B	ROOM ANT 2B

Connector No.	M86
Connector Name	REMOTE KEYLESS ENTRY RECEIVER
Connector Type	AAC04FB
Connector Color	BLACK

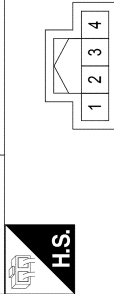

Terminal No.	Color of Wire	Signal Name
1	BG	BATTERY
2	R	RF NIMOCO
3	B	GND
4	-	-

AAKIA3786GB

A
B
C
D
E
F
G
H
I
J
DLK
L
M
N
O
P

HOMELINK UNIVERSAL TRANSCEIVER

< WIRING DIAGRAM >

HOMELINK UNIVERSAL TRANSCEIVER

Wiring Diagram

INFOID:000000013036977

HOMELINK® UNIVERSAL TRANSCEIVER

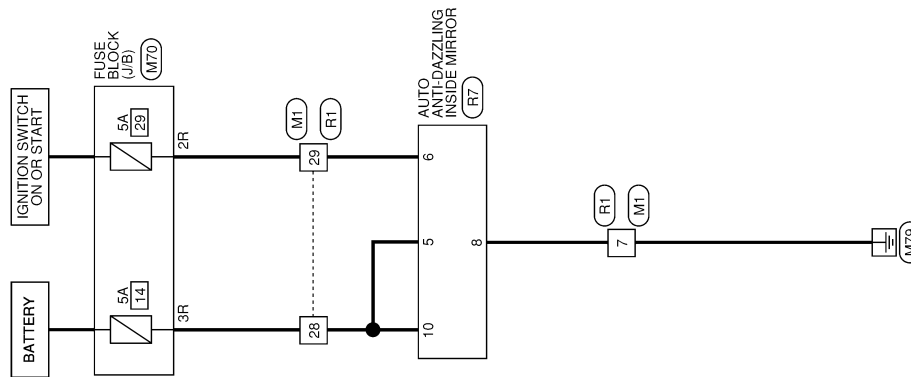

AAKWA1490GB

HOMELINK UNIVERSAL TRANSCEIVER



< WIRING DIAGRAM >

HOMELINK® UNIVERSAL TRANSCEIVER CONNECTORS

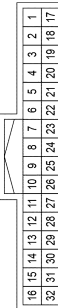
Connector No.	M1
Connector Name	WIRE TO WIRE
Connector Type	TH32FW-NH
Connector Color	WHITE

Connector No.	M70
Connector Name	FUSE BLOCK (J/B)
Connector Type	NS16FBR-CS
Connector Color	BROWN

Terminal No.	Color of Wire	Signal Name
1	SHIELD	TO ROOM LAMP HARNESS
2	R	TO ROOM LAMP HARNESS
3	W	TO ROOM LAMP HARNESS
4	SB	TO ROOM LAMP HARNESS
5	G/W	TO ROOM LAMP HARNESS
6	G/R	TO ROOM LAMP HARNESS
7	B	TO ROOM LAMP HARNESS
8	L	TO ROOM LAMP HARNESS
9	R/G	TO ROOM LAMP HARNESS
10	G	TO ROOM LAMP HARNESS
11	L/W	TO ROOM LAMP HARNESS
12	L	TO ROOM LAMP HARNESS
13	GR	TO ROOM LAMP HARNESS
14	R	TO ROOM LAMP HARNESS
15	W/B	TO ROOM LAMP HARNESS
16	L/B	TO ROOM LAMP HARNESS
17	-	TO ROOM LAMP HARNESS
18	P	TO ROOM LAMP HARNESS
19	W/L	TO ROOM LAMP HARNESS
20	W/B	TO ROOM LAMP HARNESS
21	-	TO ROOM LAMP HARNESS
22	-	TO ROOM LAMP HARNESS
23	-	TO ROOM LAMP HARNESS
24	-	TO ROOM LAMP HARNESS
25	-	TO ROOM LAMP HARNESS
26	-	TO ROOM LAMP HARNESS
27	Y/R	TO ROOM LAMP HARNESS
28	G/R	TO ROOM LAMP HARNESS
29	G/W	TO ROOM LAMP HARNESS
30	L/G/B	TO ROOM LAMP HARNESS
31	Y/V	TO ROOM LAMP HARNESS
32	-	TO ROOM LAMP HARNESS

Terminal No.	Color of Wire	Signal Name
1R	L	TAIL LAMP 2
2R	G/R	IGNITION
3R	Y/R	BATTERY
4R	-	-
5R	W	BATTERY
6R	G/W	ACCESSORY
7R	R	BATTERY
8R	-	-
9R	-	-
10R	W	BATTERY
11R	-	-
12R	BG	BATTERY
13R	B	ACCESSORY
14R	G/Y	BATTERY
15R	Y	BATTERY
16R	G/R	ACCESSORY

Connector No.	R1
Connector Name	WIRE TO WIRE
Connector Type	TH32MW-NH
Connector Color	WHITE



8	L	TO MAIN HARNESS
9	R/G	TO MAIN HARNESS
10	G	TO MAIN HARNESS
11	L/W	TO MAIN HARNESS
12	L	TO MAIN HARNESS
13	GR	TO MAIN HARNESS
14	R	TO MAIN HARNESS
15	W/B	TO MAIN HARNESS
16	L/B	TO MAIN HARNESS
17	-	TO MAIN HARNESS
18	P	TO MAIN HARNESS
19	W/L	TO MAIN HARNESS
20	W/B	TO MAIN HARNESS
21	-	TO MAIN HARNESS
22	-	TO MAIN HARNESS
23	-	TO MAIN HARNESS
24	-	TO MAIN HARNESS
25	-	TO MAIN HARNESS
26	-	TO MAIN HARNESS
27	-	TO MAIN HARNESS
28	Y/R	TO MAIN HARNESS
29	G/R	TO MAIN HARNESS
30	G/W	TO MAIN HARNESS
31	L/G/B	TO MAIN HARNESS
32	Y/V	TO MAIN HARNESS

Connector No.	R7
Connector Name	AUTO ANTI-DAZZLING INSIDE MIRROR
Connector Type	TH10FB-NH
Connector Color	BLACK



Terminal No.	Color of Wire	Signal Name
1	-	-
2	-	-
3	-	-
4	L/G/B	EC FEED
5	Y/R	BATTERY
6	G/W	IGNITION POWER
7	G/W	REVERSE RELAY
8	B	GROUND
9	Y/V	EC RETURN
10	Y/R	BATTERY

Terminal No.	Color of Wire	Signal Name
1	SHIELD	TO MAIN HARNESS
2	R	TO MAIN HARNESS
3	W	TO MAIN HARNESS
4	Y/R	TO MAIN HARNESS
5	G/W	TO MAIN HARNESS
6	G/R	TO MAIN HARNESS
7	B	TO MAIN HARNESS

A
B
C
D
E
F
G
H
I
J
K
L
M
N
O
P

DLK

POWER DOOR LOCK SYSTEM

< WIRING DIAGRAM >

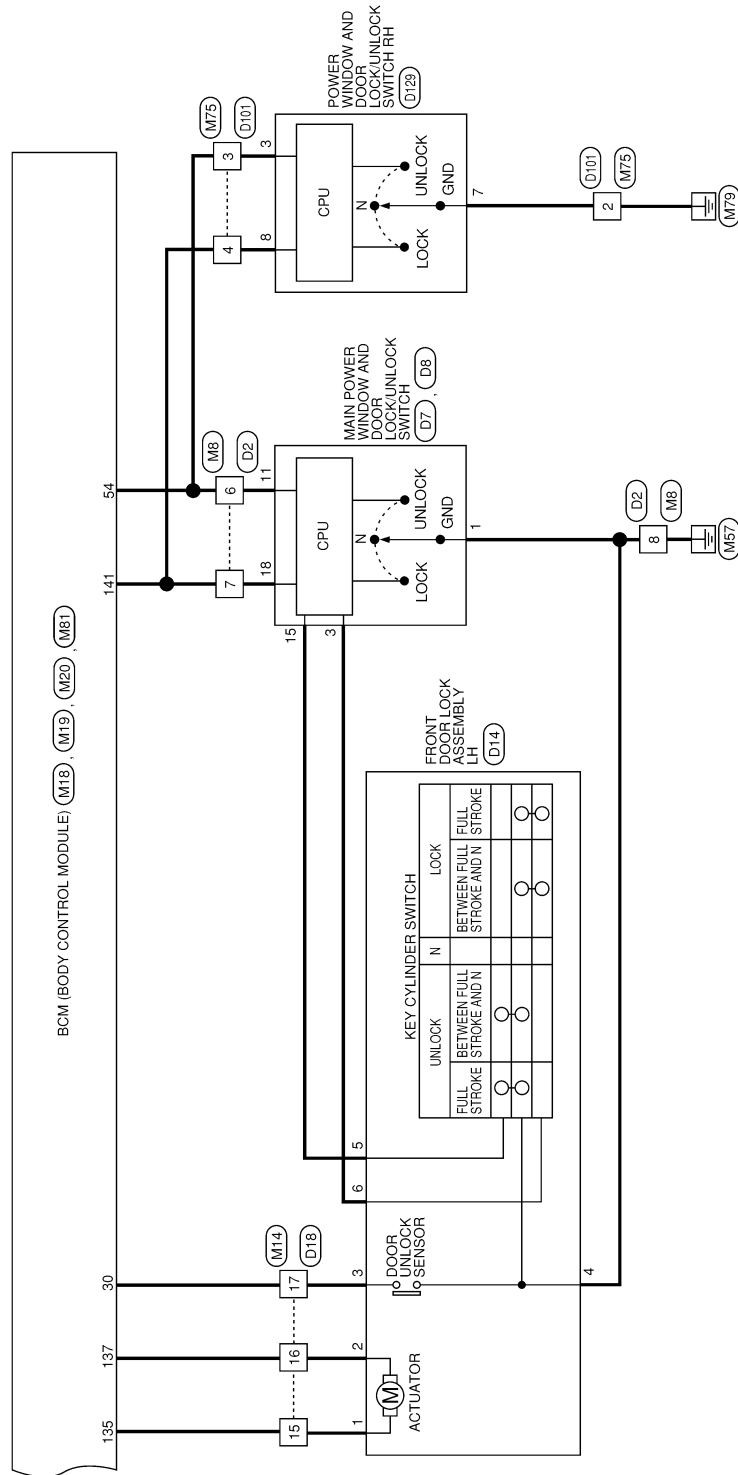

AAKWA1495GB

A
B
C
D
E
F
G
H
I
J
DLK
L
M
N
O
P

POWER DOOR LOCK SYSTEM

< WIRING DIAGRAM >

POWER DOOR LOCK SYSTEM CONNECTORS

Connector No.	B6
Connector Name	WIRE TO WIRE
Connector Type	TK10FW-NS8
Connector Color	WHITE

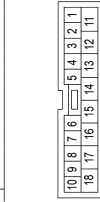

H.S.

Connector No.	B18
Connector Name	REAR DOOR SWITCH LH
Connector Type	TH04FW-NH
Connector Color	WHITE

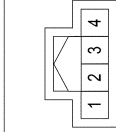

H.S.

Terminal No.	Color of Wire	Signal Name
1	-	TO REAR DOOR LH HARNESS
2	-	TO REAR DOOR LH HARNESS
3	-	TO REAR DOOR LH HARNESS
4	-	TO REAR DOOR LH HARNESS
5	-	TO REAR DOOR LH HARNESS
6	-	TO REAR DOOR LH HARNESS
7	-	TO REAR DOOR LH HARNESS
8	O/L	TO REAR DOOR LH HARNESS
9	-	TO REAR DOOR LH HARNESS
10	-	TO REAR DOOR LH HARNESS
11	B/Y	TO REAR DOOR LH HARNESS
12	SB	TO REAR DOOR LH HARNESS
13	BR	TO REAR DOOR LH HARNESS
14	Y	TO REAR DOOR LH HARNESS
15	B	TO REAR DOOR LH HARNESS
16	LG	TO REAR DOOR LH HARNESS
17	L	TO REAR DOOR LH HARNESS
18	SB	TO REAR DOOR LH HARNESS

Connector No.	B8
Connector Name	FRONT DOOR SWITCH LH
Connector Type	TH04FW-NH
Connector Color	WHITE

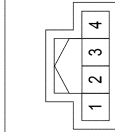

H.S.

Terminal No.	Color of Wire	Signal Name
1	-	-
2	-	-
3	L	DR DOOR SW
4	-	-

AAKIA37876B

Terminal No.	Color of Wire	Signal Name
91	BR	TO MAIN HARNESS
10J	BR	TO MAIN HARNESS
11J	O/B	TO MAIN HARNESS
12J	L	TO MAIN HARNESS
13J	SB/O	TO MAIN HARNESS
14J	Y	TO MAIN HARNESS
15J	-	TO MAIN HARNESS
16J	R	TO MAIN HARNESS
17J	G	TO MAIN HARNESS
18J	SB	TO MAIN HARNESS
19J	O	TO MAIN HARNESS
20J	O/B	TO MAIN HARNESS
21J	Y/R	TO MAIN HARNESS
22J	P	TO MAIN HARNESS
23J	W	TO MAIN HARNESS
24J	W/R	TO MAIN HARNESS
25J	V	TO MAIN HARNESS
26J	L	TO MAIN HARNESS
27J	R	TO MAIN HARNESS
28J	L	TO MAIN HARNESS
29J	G/O	TO MAIN HARNESS
30J	SB	TO MAIN HARNESS
31J	LG	TO MAIN HARNESS
32J	R	TO MAIN HARNESS
33J	L	TO MAIN HARNESS
34J	Y	TO MAIN HARNESS
35J	P	TO MAIN HARNESS
36J	G/R	TO MAIN HARNESS
37J	LG/B	TO MAIN HARNESS
38J	SB	TO MAIN HARNESS
39J	Y/L	TO MAIN HARNESS
40J	BR	TO MAIN HARNESS
41J	L	TO MAIN HARNESS
42J	L	TO MAIN HARNESS
43J	SB	TO MAIN HARNESS
44J	BR	TO MAIN HARNESS
45J	BG	TO MAIN HARNESS
46J	P/Y	TO MAIN HARNESS
47J	Y/G/R	TO MAIN HARNESS
48J	V	TO MAIN HARNESS
49J	BR/Y	TO MAIN HARNESS
50J	G/W	TO MAIN HARNESS
51J	-	TO MAIN HARNESS
52J	SHIELD	TO MAIN HARNESS
53J	R	TO MAIN HARNESS
54J	L	TO MAIN HARNESS
55J	R	TO MAIN HARNESS
56J	W	TO MAIN HARNESS
57J	L/G	TO MAIN HARNESS
58J	O	TO MAIN HARNESS
59J	-	TO MAIN HARNESS
60J	SHIELD	TO MAIN HARNESS
61J	G	TO MAIN HARNESS

Terminal No.	Color of Wire	Signal Name
62J	-	TO MAIN HARNESS
63J	R/W	TO MAIN HARNESS
64J	L/W	TO MAIN HARNESS
65J	SHIELD	TO MAIN HARNESS
66J	B	TO MAIN HARNESS
67J	SHIELD	TO MAIN HARNESS
68J	O/L	TO MAIN HARNESS
69J	SHIELD	TO MAIN HARNESS
70J	BR	TO MAIN HARNESS
71J	L/W	TO MAIN HARNESS
72J	-	TO MAIN HARNESS
73J	-	TO MAIN HARNESS
74J	SHIELD	TO MAIN HARNESS
75J	LG/B	TO MAIN HARNESS
76J	R	TO MAIN HARNESS
77J	SHIELD	TO MAIN HARNESS
78J	GR/B	TO MAIN HARNESS
79J	B	TO MAIN HARNESS
80J	W	TO MAIN HARNESS
81J	SHIELD	TO MAIN HARNESS
82J	L/R	TO MAIN HARNESS
83J	-	TO MAIN HARNESS
84J	-	TO MAIN HARNESS
85J	Y/B	TO MAIN HARNESS
86J	G	TO MAIN HARNESS
87J	BR	TO MAIN HARNESS
88J	SHIELD	TO MAIN HARNESS
89J	GR/R	TO MAIN HARNESS
90J	L	TO MAIN HARNESS
91J	L/B	TO MAIN HARNESS
92J	SB	TO MAIN HARNESS
93J	B	TO MAIN HARNESS
94J	L	TO MAIN HARNESS
95J	LG	TO MAIN HARNESS
96J	R	TO MAIN HARNESS
97J	B/Y	TO MAIN HARNESS
98J	L/B	TO MAIN HARNESS
99J	W/L	TO MAIN HARNESS
100J	SB	TO MAIN HARNESS

POWER DOOR LOCK SYSTEM

< WIRING DIAGRAM >

POWER DOOR LOCK SYSTEM CONNECTORS

Connector No.	B106
Connector Name	WIRE TO WIRE
Connector Type	TK10FW-NS8
Connector Color	WHITE

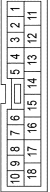

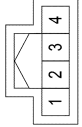

Terminal No.	Color of Wire	Signal Name
1	-	TO REAR DOOR RH HARNESS
2	-	TO REAR DOOR RH HARNESS
3	-	TO REAR DOOR RH HARNESS
4	-	TO REAR DOOR RH HARNESS
5	-	TO REAR DOOR RH HARNESS
6	-	TO REAR DOOR RH HARNESS
7	-	TO REAR DOOR RH HARNESS
8	O/L	TO REAR DOOR RH HARNESS
9	-	TO REAR DOOR RH HARNESS
10	-	TO REAR DOOR RH HARNESS
11	R/L	TO REAR DOOR RH HARNESS
12	O/L	TO REAR DOOR RH HARNESS
13	Y/LG	TO REAR DOOR RH HARNESS
14	BR/O	TO REAR DOOR RH HARNESS
15	B	TO REAR DOOR RH HARNESS
16	SB/R	TO REAR DOOR RH HARNESS
17	L	TO REAR DOOR RH HARNESS
18	V	TO REAR DOOR RH HARNESS

Connector No.	B108
Connector Name	FRONT DOOR SWITCH RH
Connector Type	TH04FW-NH
Connector Color	WHITE



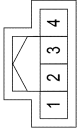

Connector No.	B116
Connector Name	REAR DOOR SWITCH RH
Connector Type	TH04FW-NH
Connector Color	WHITE

Terminal No.	Color of Wire	Signal Name
1	-	-
2	-	-
3	LG	RR DOOR SW
4	-	-

Connector No.	B149
Connector Name	WIRE TO WIRE
Connector Type	TH80MDGY-CS16-TM4
Connector Color	GRAY

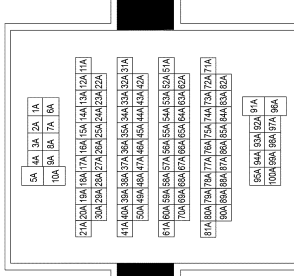
Terminal No.	Color of Wire	Signal Name
1A	SB/G	TO MAIN HARNESS (WITHOUT CLIMATE CONTROLLED SEATS)
1A	SB	TO MAIN HARNESS (WITH CLIMATE CONTROLLED SEATS)
2A	L	TO MAIN HARNESS
3A	V	TO MAIN HARNESS
4A	SB/R	TO MAIN HARNESS
5A	-	TO MAIN HARNESS

57A	-	TO MAIN HARNESS
58A	-	TO MAIN HARNESS
59A	-	TO MAIN HARNESS
60A	G/W	TO MAIN HARNESS
61A	-	TO MAIN HARNESS
62A	-	TO MAIN HARNESS
63A	-	TO MAIN HARNESS
64A	-	TO MAIN HARNESS
65A	-	TO MAIN HARNESS
66A	-	TO MAIN HARNESS
67A	-	TO MAIN HARNESS
68A	-	TO MAIN HARNESS
69A	Y/R	TO MAIN HARNESS
70A	R/G	TO MAIN HARNESS
71A	-	TO MAIN HARNESS
72A	Y/B	TO MAIN HARNESS
73A	G	TO MAIN HARNESS
74A	B/R	TO MAIN HARNESS
75A	SHIELD	TO MAIN HARNESS
76A	GR/R	TO MAIN HARNESS
77A	L	TO MAIN HARNESS
78A	SHIELD	TO MAIN HARNESS
79A	Y	TO MAIN HARNESS
80A	L	TO MAIN HARNESS
81A	R	TO MAIN HARNESS
82A	SHIELD	TO MAIN HARNESS
83A	LG/B	TO MAIN HARNESS
84A	R	TO MAIN HARNESS
85A	SHIELD	TO MAIN HARNESS
86A	GR/B	TO MAIN HARNESS
87A	B	TO MAIN HARNESS
88A	W	TO MAIN HARNESS
89A	SHIELD	TO MAIN HARNESS
90A	G	TO MAIN HARNESS
91A	W/L	TO MAIN HARNESS
92A	BR	TO MAIN HARNESS
93A	L/Y	TO MAIN HARNESS
94A	R/L	TO MAIN HARNESS
95A	BR	TO MAIN HARNESS
96A	R	TO MAIN HARNESS
97A	LG	TO MAIN HARNESS
98A	B/V	TO MAIN HARNESS
99A	O/L	TO MAIN HARNESS
100A	BR/W	TO MAIN HARNESS

6A	LG/Y	TO MAIN HARNESS (WITHOUT CLIMATE CONTROLLED SEATS)
6A	LG	TO MAIN HARNESS (WITH CLIMATE CONTROLLED SEATS)
7A	W	TO MAIN HARNESS
8A	B	TO MAIN HARNESS
9A	L/B	TO MAIN HARNESS
10A	W	TO MAIN HARNESS
11A	LG	TO MAIN HARNESS
12A	BR/O	TO MAIN HARNESS
13A	Y/W	TO MAIN HARNESS
14A	R/G	TO MAIN HARNESS
15A	Y/L	TO MAIN HARNESS
16A	O/L	TO MAIN HARNESS
17A	L	TO MAIN HARNESS
18A	Y	TO MAIN HARNESS
19A	LG	TO MAIN HARNESS
20A	BR/Y	TO MAIN HARNESS
21A	BG	TO MAIN HARNESS
22A	LG/R	TO MAIN HARNESS
23A	Y/LG	TO MAIN HARNESS
24A	BR/Y	TO MAIN HARNESS
25A	-	TO MAIN HARNESS
26A	GR	TO MAIN HARNESS
27A	LG	TO MAIN HARNESS
28A	LG/B	TO MAIN HARNESS
29A	-	TO MAIN HARNESS
30A	-	TO MAIN HARNESS
31A	W/R	TO MAIN HARNESS
32A	G/R	TO MAIN HARNESS
33A	-	TO MAIN HARNESS
34A	SHIELD	TO MAIN HARNESS
35A	P	TO MAIN HARNESS
36A	B	TO MAIN HARNESS
37A	-	TO MAIN HARNESS
38A	R/B	TO MAIN HARNESS
39A	G/O	TO MAIN HARNESS
40A	V	TO MAIN HARNESS
41A	SHIELD	TO MAIN HARNESS
42A	SHIELD	TO MAIN HARNESS
43A	R	TO MAIN HARNESS
44A	G	TO MAIN HARNESS
45A	-	TO MAIN HARNESS
46A	-	TO MAIN HARNESS
47A	Y	TO MAIN HARNESS
48A	R/W	TO MAIN HARNESS
49A	R/L	TO MAIN HARNESS
50A	B	TO MAIN HARNESS
51A	-	TO MAIN HARNESS
52A	-	TO MAIN HARNESS
53A	-	TO MAIN HARNESS
54A	-	TO MAIN HARNESS
55A	-	TO MAIN HARNESS
56A	-	TO MAIN HARNESS

A B C D E F G H I J L M N O P

DLK

AAKIA37886B

POWER DOOR LOCK SYSTEM

< WIRING DIAGRAM >

POWER DOOR LOCK SYSTEM CONNECTORS

Connector No.	D2
Connector Name	WIRE TO WIRE
Connector Type	NS16FW-CS
Connector Color	WHITE

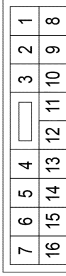
Terminal No.	Color of Wire	Signal Name
1	B/W	TO MAIN HARNESS
2	G/B	TO MAIN HARNESS
3	L	TO MAIN HARNESS
4	R	TO MAIN HARNESS
5	W/R	TO MAIN HARNESS
6	W/L	TO MAIN HARNESS
7	V	TO MAIN HARNESS
8	B	TO MAIN HARNESS
9	L/W	TO MAIN HARNESS
10	L/R	TO MAIN HARNESS
11	L/W	TO MAIN HARNESS
12	L	TO MAIN HARNESS
13	Y	TO MAIN HARNESS
14	SB	TO MAIN HARNESS
15	V	TO MAIN HARNESS
16	LG	TO MAIN HARNESS



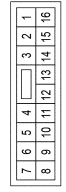

Connector No.	D7
Connector Name	MAIN POWER WINDOW AND DOOR LOCK/UNLOCK SWITCH
Connector Type	NS16FW-CS
Connector Color	WHITE



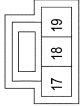

6	SB	RR DN
7	V	RR UP
8	L	RL DN
9	Y	RL UP
10	LG	IGN
11	W/L	COM
12	B	ENCODER_GND
13	-	-
14	P	ENCODER+
15	B/W	D LOCK ACTR DR
16	-	-

Connector No.	D8
Connector Name	MAIN POWER WINDOW AND DOOR LOCK/UNLOCK SWITCH
Connector Type	NS03FW-CS
Connector Color	WHITE

Terminal No.	Color of Wire	Signal Name
17	W	DR UP
18	V	BAT
19	R	DR DN



Connector No.	D14
Connector Name	FRONT DOOR LOCK ASSEMBLY LH
Connector Type	E06FGY-RS
Connector Color	GRAY

Terminal No.	Color of Wire	Signal Name
1	L	DOOR LOCK DR
2	V	DOOR UNLOCK DR
3	LG	DR DOOR LOCK STATUS GROUND
4	B	GROUND
5	B/W	UNLOCK SW

6	W/R	LOCK SW
---	-----	---------

Connector No.	D18
Connector Name	WIRE TO WIRE
Connector Type	TH40FW-NH
Connector Color	WHITE

Terminal No.	Color of Wire	Signal Name
1	SB	TO MAIN HARNESS -(WITHOUT MEMORY MIRRORS)
1	LG	TO MAIN HARNESS -(WITH AROUND VIEW MONITOR)
2	SB	TO MAIN HARNESS
3	BG	TO MAIN HARNESS
4	Y	TO MAIN HARNESS
5	BR	TO MAIN HARNESS
6	SB	TO MAIN HARNESS
7	V	TO MAIN HARNESS
8	GR	TO MAIN HARNESS
9	L	TO MAIN HARNESS
10	W	TO MAIN HARNESS
11	B	TO MAIN HARNESS
12	R/G	TO MAIN HARNESS
13	Y	TO MAIN HARNESS
14	LG	TO MAIN HARNESS
15	L	TO MAIN HARNESS
16	V	TO MAIN HARNESS
17	LG	TO MAIN HARNESS
18	BR	TO MAIN HARNESS
19	LG/B	TO MAIN HARNESS
20	Y/V	TO MAIN HARNESS
21	BR	TO MAIN HARNESS -(WITHOUT MEMORY MIRRORS)
21	BG	TO MAIN HARNESS -(WITH MEMORY MIRRORS)
22	V	TO MAIN HARNESS
23	G	TO MAIN HARNESS -(WITHOUT MEMORY MIRRORS)
23	L	TO MAIN HARNESS -(WITH MEMORY MIRRORS)
24	LG	TO MAIN HARNESS
25	Y	TO MAIN HARNESS
26	L	TO MAIN HARNESS
27	Y	TO MAIN HARNESS
28	L	TO MAIN HARNESS
29	V	TO MAIN HARNESS
30	R	TO MAIN HARNESS

31	SHIELD	TO MAIN HARNESS
32	R	TO MAIN HARNESS
33	BR	TO MAIN HARNESS
34	-	TO MAIN HARNESS
35	W	TO MAIN HARNESS
36	-	TO MAIN HARNESS
37	-	TO MAIN HARNESS
38	LG	TO MAIN HARNESS
39	SB	TO MAIN HARNESS
40	L	TO MAIN HARNESS

Connector No.	D101
Connector Name	WIRE TO WIRE
Connector Type	NS10FW-CS
Connector Color	WHITE

Terminal No.	Color of Wire	Signal Name
1	B/W	TO MAIN HARNESS
2	B	TO MAIN HARNESS
3	W/L	TO MAIN HARNESS
4	V	TO MAIN HARNESS
5	W/B	TO MAIN HARNESS
6	G/Y	TO MAIN HARNESS
7	W/B	TO MAIN HARNESS
8	L/B	TO MAIN HARNESS
9	G/Y	TO MAIN HARNESS
10	-	TO MAIN HARNESS

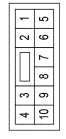
POWER DOOR LOCK SYSTEM

< WIRING DIAGRAM >

POWER DOOR LOCK SYSTEM CONNECTORS

Connector No.	D102
Connector Name	WIRE TO WIRE
Connector Type	TH32FW-NH
Connector Color	WHITE

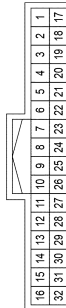
Connector No.	D114
Connector Name	FRONT DOOR LOCK ACTUATOR RH
Connector Type	E06FGY-RS
Connector Color	GRAY



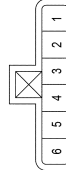

Connector No.	D201
Connector Name	WIRE TO WIRE
Connector Type	TK10MW-NS8
Connector Color	WHITE

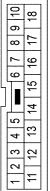
5	-	-
6	-	-

Connector No.	D301
Connector Name	WIRE TO WIRE
Connector Type	TK10MW-NS8
Connector Color	WHITE

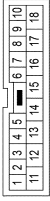
Terminal No.	Color of Wire	Signal Name
1	BR	TO MAIN HARNESS
2	V	TO MAIN HARNESS
3	BR	TO MAIN HARNESS
4	L	TO MAIN HARNESS
5	LG/W	TO MAIN HARNESS
6	R/W	TO MAIN HARNESS
7	R/G	TO MAIN HARNESS
8	B	TO MAIN HARNESS
9	W	TO MAIN HARNESS
10	Y	TO MAIN HARNESS
11	LG	TO MAIN HARNESS
12	L	TO MAIN HARNESS
13	Y/V	TO MAIN HARNESS
14	W/L	TO MAIN HARNESS
15	V/R	TO MAIN HARNESS
16	L/W	TO MAIN HARNESS
17	SB	TO MAIN HARNESS
18	Y	TO MAIN HARNESS
19	G	TO MAIN HARNESS
20	V/W	TO MAIN HARNESS (WITHOUT AUTOMATIC DRIVE POSITIONER)
21	GR/R	TO MAIN HARNESS (WITH AUTOMATIC DRIVE POSITIONER)
22	-	TO MAIN HARNESS
23	R	TO MAIN HARNESS
24	R	TO MAIN HARNESS
25	SHIELD	TO MAIN HARNESS
26	LG	TO MAIN HARNESS
27	Y	TO MAIN HARNESS
28	BR	TO MAIN HARNESS
29	LG/B	TO MAIN HARNESS
30	-	TO MAIN HARNESS
31	-	TO MAIN HARNESS
32	-	TO MAIN HARNESS

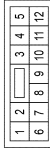

Connector No.	D129
Connector Name	POWER WINDOW AND DOOR LOCK/UNLOCK SWITCH RH
Connector Type	NS12FW-CS
Connector Color	WHITE

Terminal No.	Color of Wire	Signal Name
1	-	TO BODY HARNESS
2	-	TO BODY HARNESS
3	-	TO BODY HARNESS
4	-	TO BODY HARNESS
5	-	TO BODY HARNESS
6	-	TO BODY HARNESS
7	-	TO BODY HARNESS
8	O/L	TO BODY HARNESS
9	-	TO BODY HARNESS
10	-	TO BODY HARNESS
11	B/Y	TO BODY HARNESS
12	SB	TO BODY HARNESS
13	BR	TO BODY HARNESS
14	Y	TO BODY HARNESS
15	B	TO BODY HARNESS
16	BR	TO BODY HARNESS
17	Y	TO BODY HARNESS
18	V	TO BODY HARNESS

Terminal No.	Color of Wire	Signal Name
1	-	TO BODY NO. 2 HARNESS
2	-	TO BODY NO. 2 HARNESS
3	-	TO BODY NO. 2 HARNESS
4	-	TO BODY NO. 2 HARNESS
5	-	TO BODY NO. 2 HARNESS
6	-	TO BODY NO. 2 HARNESS
7	-	TO BODY NO. 2 HARNESS
8	O/L	TO BODY NO. 2 HARNESS
9	-	TO BODY NO. 2 HARNESS
10	-	TO BODY NO. 2 HARNESS
11	R/L	TO BODY NO. 2 HARNESS
12	O/L	TO BODY NO. 2 HARNESS
13	Y	TO BODY NO. 2 HARNESS
14	BR	TO BODY NO. 2 HARNESS
15	B	TO BODY NO. 2 HARNESS
16	BR	TO BODY NO. 2 HARNESS
17	Y	TO BODY NO. 2 HARNESS
18	V	TO BODY NO. 2 HARNESS

Connector No.	D205
Connector Name	REAR DOOR LOCK ACTUATOR LH
Connector Type	E06FGY-RS
Connector Color	GRAY

Terminal No.	Color of Wire	Signal Name
1	-	-
2	-	-
3	W/L	COM
4	G/B	ENCODER GND
5	W	ENCODER +
6	-	-
7	B	GND
8	V	BAT
9	R/L	ENCODER SIG1
10	L/W	ENCODER SIG2
11	G	AS UP
12	L	AS DN

AAKIA37906B

A B C D E F G H I J L M N O P

DLK

POWER DOOR LOCK SYSTEM

< WIRING DIAGRAM >

POWER DOOR LOCK SYSTEM CONNECTORS

Connector No.	D305
Connector Name	REAR DOOR LOCK ACTUATOR RH
Connector Type	E06FGY-RS
Connector Color	GRAY

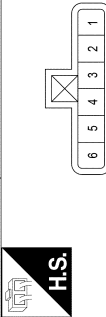

Connector No.	E152
Connector Name	WIRE TO WIRE
Connector Type	TH80MW-CS16-TM4
Connector Color	WHITE

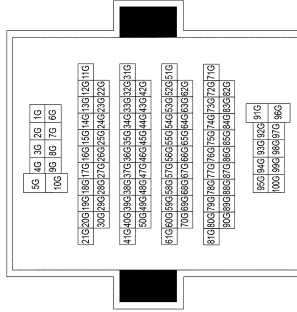

Connector No.	100G
Connector Name	M3
Connector Type	FUSE BLOCK (J/B)
Connector Color	WHITE

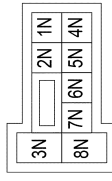

Terminal No.	1N	2N	3N	4N	5N	6N	7N	8N
Color of Wire	O	W	W	Y	W	L	W	W
Signal Name	IGN	BATTERY	IGNITION	BATTERY	BATTERY	BATTERY	ACC RELAY OUT	IGNITION

46G	W	TO MAIN HARNESS
46G	-	TO MAIN HARNESS
50G	BR	TO MAIN HARNESS
51G	R	TO MAIN HARNESS
52G	L	TO MAIN HARNESS
53G	W	TO MAIN HARNESS
54G	W	TO MAIN HARNESS
55G	G	TO MAIN HARNESS
56G	W	TO MAIN HARNESS
57G	Y	TO MAIN HARNESS
58G	EG	TO MAIN HARNESS
59G	EG	TO MAIN HARNESS
60G	EG	TO MAIN HARNESS
61G	B	TO MAIN HARNESS
62G	W	TO MAIN HARNESS
63G	R	TO MAIN HARNESS
64G	W/L	TO MAIN HARNESS
65G	W/R	TO MAIN HARNESS
66G	EG	TO MAIN HARNESS
67G	EG	TO MAIN HARNESS
68G	B	TO MAIN HARNESS
69G	Y	TO MAIN HARNESS
70G	L	TO MAIN HARNESS
71G	R/W	TO MAIN HARNESS
72G	L/W	TO MAIN HARNESS
73G	SHIELD	TO MAIN HARNESS
74G	W	TO MAIN HARNESS
75G	R	TO MAIN HARNESS
76G	R/G	TO MAIN HARNESS
77G	G	TO MAIN HARNESS
78G	W	TO MAIN HARNESS
79G	-	TO MAIN HARNESS
80G	R	TO MAIN HARNESS
81G	L	TO MAIN HARNESS
82G	R	TO MAIN HARNESS
83G	L	TO MAIN HARNESS
84G	L	TO MAIN HARNESS
85G	W/B	TO MAIN HARNESS
86G	B/R	TO MAIN HARNESS
87G	W/B	TO MAIN HARNESS
88G	P	TO MAIN HARNESS
89G	L	TO MAIN HARNESS
90G	G	TO MAIN HARNESS
91G	G	TO MAIN HARNESS
92G	V/W	TO MAIN HARNESS
93G	BR	TO MAIN HARNESS
94G	G	TO MAIN HARNESS
95G	G	TO MAIN HARNESS
96G	W	TO MAIN HARNESS
97G	R	TO MAIN HARNESS
98G	W/B	TO MAIN HARNESS
99G	BR	TO MAIN HARNESS

4G	BR/W	TO MAIN HARNESS
5G	BR	TO MAIN HARNESS
6G	P	TO MAIN HARNESS - (WITH VK58VD)
6G	R/W	TO MAIN HARNESS - (WITH CUMMINS 5.0L)
7G	Y	TO MAIN HARNESS
8G	G	TO MAIN HARNESS
9G	R	TO MAIN HARNESS
10G	W	TO MAIN HARNESS
11G	R/G	TO MAIN HARNESS
12G	W/B	TO MAIN HARNESS
13G	BR	TO MAIN HARNESS
14G	Y/B	TO MAIN HARNESS
15G	G/W	TO MAIN HARNESS
16G	G	TO MAIN HARNESS
17G	G/Y	TO MAIN HARNESS
18G	G/Y	TO MAIN HARNESS
19G	Y/W	TO MAIN HARNESS
20G	G/Y	TO MAIN HARNESS
21G	B/Y	TO MAIN HARNESS
22G	G/R	TO MAIN HARNESS - (WITH CUMMINS 5.0L)
22G	G/Y	TO MAIN HARNESS - (WITH VK58VD)
23G	Y/R	TO MAIN HARNESS
24G	G/B	TO MAIN HARNESS
25G	R/W	TO MAIN HARNESS
26G	R	TO MAIN HARNESS
27G	L/G	TO MAIN HARNESS
28G	G/B	TO MAIN HARNESS
29G	G/B	TO MAIN HARNESS
30G	B/R/Y	TO MAIN HARNESS
31G	P	TO MAIN HARNESS - (WITH CUMMINS 5.0L)
31G	R	TO MAIN HARNESS - (WITH VK58VD)
32G	P	TO MAIN HARNESS
33G	Y/L	TO MAIN HARNESS
34G	GR	TO MAIN HARNESS
35G	G/R	TO MAIN HARNESS
36G	SB	TO MAIN HARNESS
37G	R/W	TO MAIN HARNESS
38G	BR	TO MAIN HARNESS
39G	BR	TO MAIN HARNESS
40G	-	TO MAIN HARNESS
41G	R/G	TO MAIN HARNESS
42G	O	TO MAIN HARNESS
43G	B	TO MAIN HARNESS - (WITH CUMMINS 5.0L)
43G	G	TO MAIN HARNESS - (WITH VK58VD)
44G	R/Y	TO MAIN HARNESS
45G	G	TO MAIN HARNESS
46G	L/G	TO MAIN HARNESS
47G	R	TO MAIN HARNESS

AAKTA37916B

POWER DOOR LOCK SYSTEM

< WIRING DIAGRAM >

POWER DOOR LOCK SYSTEM CONNECTORS

Connector No.	M4
Connector Name	FUSE BLOCK (J/B)
Connector Type	NS16FW-CS
Connector Color	WHITE



7P	6P	5P	4P	3P	2P	1P
16P	15P	14P	13P	12P	11P	10P
9P	8P					

Terminal No.	Color of Wire	Signal Name
1P	R	IGNITION
2P	Y	IGNITION
3P	G	IGNITION RELAY OUT
4P	B/W	RR DEF RLY
5P	B/W	RR DEF RLY
6P	O	RR DEF RLY OUT
7P	G	IGNITION
8P	W	IGNITION
9P	L	BATTERY
10P	-	-
11P	-	-
12P	-	-
13P	R	BATTERY
14P	Y	BATTERY
15P	Y/LG	BATTERY
16P	W	BLOWER FAN RELAY OUT

Connector No.	M8
Connector Name	WIRE TO WIRE
Connector Type	NS16MW-CS
Connector Color	WHITE



1	2	3	4	5	6	7
8	9	10	11	12	13	14
15	16					

Terminal No.	Color of Wire	Signal Name
1	B/W	TO FRONT DOOR LH HARNESS
2	G/B	TO FRONT DOOR LH HARNESS
3	L	TO FRONT DOOR LH HARNESS
4	R	TO FRONT DOOR LH HARNESS
5	W/R	TO FRONT DOOR LH HARNESS
6	W/L	TO FRONT DOOR LH HARNESS
7	V	TO FRONT DOOR LH HARNESS

AAKIA3792GB

8	B	TO FRONT DOOR LH HARNESS
9	L/W	TO FRONT DOOR LH HARNESS
10	L/R	TO FRONT DOOR LH HARNESS
11	L/W	TO FRONT DOOR LH HARNESS
12	L	TO FRONT DOOR LH HARNESS
13	Y	TO FRONT DOOR LH HARNESS
14	SB	TO FRONT DOOR LH HARNESS
15	V	TO FRONT DOOR LH HARNESS
16	LG	TO FRONT DOOR LH HARNESS

Connector No.	M14
Connector Name	WIRE TO WIRE
Connector Type	TH40MM-NH
Connector Color	WHITE



1	2	3	4	5	6	7	8	9	10	11	12	13	14	15	16	17	18	19	20
21	22	23	24	25	26	27	28	29	30	31	32	33	34	35	36	37	38	39	40

Terminal No.	Color of Wire	Signal Name
1	SB	TO FRONT DOOR LH HARNESS - (WITHOUT MEMORY MIRRORS)
1	LG	TO FRONT DOOR LH HARNESS - (WITH MEMORY MIRRORS)
2	SB	TO FRONT DOOR LH HARNESS
3	B	TO FRONT DOOR LH HARNESS
4	Y	TO FRONT DOOR LH HARNESS
5	V	TO FRONT DOOR LH HARNESS
6	SB	TO FRONT DOOR LH HARNESS
7	Y	TO FRONT DOOR LH HARNESS
8	GR	TO FRONT DOOR LH HARNESS
9	L	TO FRONT DOOR LH HARNESS
10	W	TO FRONT DOOR LH HARNESS
11	B	TO FRONT DOOR LH HARNESS
12	R/G	TO FRONT DOOR LH HARNESS
13	G	TO FRONT DOOR LH HARNESS
14	P	TO FRONT DOOR LH HARNESS
15	O	TO FRONT DOOR LH HARNESS
16	V	TO FRONT DOOR LH HARNESS
17	P	TO FRONT DOOR LH HARNESS
18	G	TO FRONT DOOR LH HARNESS
19	L/G/B	TO FRONT DOOR LH HARNESS
20	Y/V	TO FRONT DOOR LH HARNESS
21	BR	TO FRONT DOOR LH HARNESS - (WITHOUT MEMORY MIRRORS)
21	O	TO FRONT DOOR LH HARNESS - (WITH MEMORY MIRRORS)
22	BG	TO FRONT DOOR LH HARNESS
23	G	TO FRONT DOOR LH HARNESS - (WITHOUT MEMORY MIRRORS)

23	L	TO FRONT DOOR LH HARNESS - (WITH MEMORY MIRRORS)
24	BR	TO FRONT DOOR LH HARNESS
25	Y	TO FRONT DOOR LH HARNESS
26	LG	TO FRONT DOOR LH HARNESS
27	W	TO FRONT DOOR LH HARNESS
28	L	TO FRONT DOOR LH HARNESS
29	P	TO FRONT DOOR LH HARNESS
30	R	TO FRONT DOOR LH HARNESS
31	SHIELD	TO FRONT DOOR LH HARNESS
32	R	TO FRONT DOOR LH HARNESS
33	O	TO FRONT DOOR LH HARNESS
34	-	TO FRONT DOOR LH HARNESS
35	W	TO FRONT DOOR LH HARNESS
36	-	TO FRONT DOOR LH HARNESS
37	-	TO FRONT DOOR LH HARNESS
38	GR	TO FRONT DOOR LH HARNESS
39	P	TO FRONT DOOR LH HARNESS
40	R	TO FRONT DOOR LH HARNESS

Connector No.	M18
Connector Name	BCM (BODY CONTROL MODULE)
Connector Type	TH40FG-NH
Connector Color	GREEN



20	19	18	17	16	15	14	13	12	11	10	9	8	7	6	5	4	3	2	1
40	39	38	37	36	35	34	33	32	31	30	29	28	27	26	25	24	23	22	21

Terminal No.	Color of Wire	Signal Name
1	G	ENG START SW NO ESCL
2	-	-
3	R	A/L POWER SUPPLY 5V
4	W/R	A/L SIGNAL
5	-	-
6	-	-
7	-	-
8	-	-
9	-	-
10	SB	COMBI SW IN 5
11	G/Y	COMBI SW IN 4
12	Y	COMBI SW IN 3
13	G/B	COMBI SW IN 2
14	V	COMBI SW IN 1
15	-	-
16	-	-
17	P	GND RF A/L
18	V	SECURITY INDICATOR

19	-	-
20	R	SHIFT P
21	R/W	STEP LAMP CONT
22	-	-
23	Y	AIRCON SW
24	-	-
25	W	BRAKE SW FUSE
26	L	SHORT IN PIN INPUT
27	R/G	BRAKE SW LAMP
28	-	-
29	W	BLOWER FAN SW
30	P	DR DOOR LOCK STATUS
31	-	-
32	Y	REAR DEFOGGER SW
33	-	-
34	-	-
35	R/G	REVERSE SW
36	W/B	HAZARD SW
37	-	-
38	-	-
39	B/R	SHIFT N/P
40	-	-

A
B
C
D
E
F
G
H
I
J
K
L
M
N
O
P

DLK

POWER DOOR LOCK SYSTEM

< WIRING DIAGRAM >

POWER DOOR LOCK SYSTEM CONNECTORS

Connector No.	M19
Connector Name	BCM (BODY CONTROL MODULE)
Connector Type	TH40FB-NH
Connector Color	BLACK

60	59	58	57	56	55	54	53	52	51	50	49	48	47	46	45	44	43	42	41
80	79	78	77	76	75	74	73	72	71	70	69	68	67	66	65	64	63	62	61



78	O/B	COMBI SW OUT 2
79	R/W	COMBI SW OUT 1
80	-	-

Connector No.	M20
Connector Name	BCM (BODY CONTROL MODULE)
Connector Type	TH24FGY-NH
Connector Color	GRAY

92	91	90	89	88	87	86	85	84	83	82	81
104	103	102	101	100	99	98	97	96	95	94	93



Terminal No.	Color of Wire	Signal Name
41	YL	TRAILER LIGHT CHECK RELAY OUT
42	RY	CARGO LAMP OUT
43	-	-
44	-	-
45	-	-
46	-	-
47	-	-
48	R	HIGH SIDE START SW LED
49	-	-
50	-	-
51	-	-
52	W	AUDIO DONGLE
53	-	-
54	W/L	PW UART
55	W/B	L&R SENSOR K-LINE
56	-	-
57	-	-
58	-	-
59	P	CAN-L
60	L	CAN-H
61	O	REAR DEFOGGER RELAY OUT
62	W	STARTER RELAY OUT
63	-	-
64	P	BUZZER OUT
65	-	-
66	W	BLOWER FAN RELAY OUT
67	G	IGN ELEC RELAY OUT 2
68	L	MR OUTPUT
69	R/B	AT DEVICE OUT
70	P	IGN USM OUT 1
71	O	DR REQUEST SW
72	G	AS REQUEST SW
73	-	-
74	-	-
75	L/W	COMBI SW OUT 5
76	P	COMBI SW OUT 4
77	L	COMBI SW OUT 3

AAKIA3793GB

Terminal No.	Color of Wire	Signal Name
81	-	-
82	W	RL DOOR SW
83	-	-
84	-	-
85	-	-
86	G/B	TRAILER FLASHER RL
87	Y/B	TRAILER FLASHER RR
88	-	-
89	-	-
90	-	-
91	-	-
92	O	RR FLASHER
93	R	RR DOOR SW
94	G	AS DOOR SW
95	-	-
96	BG	DR DOOR SW
97	P/L	CARGO LAMP SW
98	-	-
99	-	-
100	-	-
101	-	-
102	-	-
103	G/B	RL FLASHER
104	-	-

POWER DOOR LOCK SYSTEM

< WIRING DIAGRAM >

POWER DOOR LOCK SYSTEM CONNECTORS

Connector No.	M31
Connector Name	WIRE TO WIRE
Connector Type	TH80FW-CS16-TM4
Connector Color	WHITE

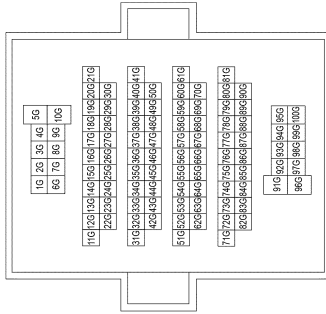

Terminal No.	Color of Wire	Signal Name
1G	G	TO ENGINE ROOM HARNESS
2G	B/R	TO ENGINE ROOM HARNESS
3G	W	TO ENGINE ROOM HARNESS
4G	B/W	TO ENGINE ROOM HARNESS
5G	BR	TO ENGINE ROOM HARNESS
6G	R/W	TO ENGINE ROOM HARNESS
7G	Y	TO ENGINE ROOM HARNESS
8G	G	TO ENGINE ROOM HARNESS
9G	R	TO ENGINE ROOM HARNESS
10G	W	TO ENGINE ROOM HARNESS
11G	P/G	TO ENGINE ROOM HARNESS
12G	W/B	TO ENGINE ROOM HARNESS
13G	BR	TO ENGINE ROOM HARNESS
14G	Y/B	TO ENGINE ROOM HARNESS
15G	G/W	TO ENGINE ROOM HARNESS
16G	G	TO ENGINE ROOM HARNESS
17G	O	TO ENGINE ROOM HARNESS
18G	G/Y	TO ENGINE ROOM HARNESS
19G	Y/W	TO ENGINE ROOM HARNESS
20G	G/Y	TO ENGINE ROOM HARNESS
21G	B/Y	TO ENGINE ROOM HARNESS
22G	G/R	TO ENGINE ROOM HARNESS - (WITH CUMMINS 5.0L)
22G	G/Y	TO ENGINE ROOM HARNESS - (WITH V6.56/D)
23G	Y/R	TO ENGINE ROOM HARNESS
24G	G/B	TO ENGINE ROOM HARNESS

AAKIA37946B

76G	P	TO ENGINE ROOM HARNESS
76G	-	TO ENGINE ROOM HARNESS
80G	R	TO ENGINE ROOM HARNESS
81G	L	TO ENGINE ROOM HARNESS
82G	R	TO ENGINE ROOM HARNESS
83G	L	TO ENGINE ROOM HARNESS
84G	L	TO ENGINE ROOM HARNESS
86G	W	TO ENGINE ROOM HARNESS
86G	B/R	TO ENGINE ROOM HARNESS
87G	W	TO ENGINE ROOM HARNESS
88G	G	TO ENGINE ROOM HARNESS
89G	P	TO ENGINE ROOM HARNESS
90G	G	TO ENGINE ROOM HARNESS
91G	P	TO ENGINE ROOM HARNESS
92G	V/W	TO ENGINE ROOM HARNESS
93G	BR	TO ENGINE ROOM HARNESS
94G	B	TO ENGINE ROOM HARNESS
95G	G	TO ENGINE ROOM HARNESS
96G	R	TO ENGINE ROOM HARNESS
97G	R	TO ENGINE ROOM HARNESS
98G	W/B	TO ENGINE ROOM HARNESS
99G	R	TO ENGINE ROOM HARNESS
100G	GRW	TO ENGINE ROOM HARNESS

25G	R/W	TO ENGINE ROOM HARNESS
26G	R	TO ENGINE ROOM HARNESS
27G	LG	TO ENGINE ROOM HARNESS
28G	G/B	TO ENGINE ROOM HARNESS
29G	G/B	TO ENGINE ROOM HARNESS
30G	B/Y	TO ENGINE ROOM HARNESS
31G	R	TO ENGINE ROOM HARNESS
32G	R	TO ENGINE ROOM HARNESS
33G	Y/L	TO ENGINE ROOM HARNESS
34G	GR	TO ENGINE ROOM HARNESS
35G	G/R	TO ENGINE ROOM HARNESS
36G	SB	TO ENGINE ROOM HARNESS
37G	R/W	TO ENGINE ROOM HARNESS
38G	BR	TO ENGINE ROOM HARNESS
38G	BR	TO ENGINE ROOM HARNESS
40G	-	TO ENGINE ROOM HARNESS
41G	R/G	TO ENGINE ROOM HARNESS
42G	O	TO ENGINE ROOM HARNESS
43G	G	TO ENGINE ROOM HARNESS
44G	P/Y	TO ENGINE ROOM HARNESS
45G	G	TO ENGINE ROOM HARNESS
46G	LG	TO ENGINE ROOM HARNESS
47G	R	TO ENGINE ROOM HARNESS
48G	W	TO ENGINE ROOM HARNESS
49G	-	TO ENGINE ROOM HARNESS
50G	BR	TO ENGINE ROOM HARNESS
51G	R	TO ENGINE ROOM HARNESS
52G	L	TO ENGINE ROOM HARNESS
53G	W	TO ENGINE ROOM HARNESS
54G	W	TO ENGINE ROOM HARNESS
55G	G	TO ENGINE ROOM HARNESS
56G	W	TO ENGINE ROOM HARNESS
57G	Y	TO ENGINE ROOM HARNESS
58G	BG	TO ENGINE ROOM HARNESS
59G	BG	TO ENGINE ROOM HARNESS
60G	BG	TO ENGINE ROOM HARNESS
61G	O	TO ENGINE ROOM HARNESS
62G	W	TO ENGINE ROOM HARNESS
63G	O	TO ENGINE ROOM HARNESS
64G	W/L	TO ENGINE ROOM HARNESS
65G	W/R	TO ENGINE ROOM HARNESS
66G	BG	TO ENGINE ROOM HARNESS
67G	O	TO ENGINE ROOM HARNESS
68G	B	TO ENGINE ROOM HARNESS
69G	Y	TO ENGINE ROOM HARNESS
70G	L	TO ENGINE ROOM HARNESS
71G	R/W	TO ENGINE ROOM HARNESS
72G	L/W	TO ENGINE ROOM HARNESS
73G	SHIELD	TO ENGINE ROOM HARNESS
74G	W	TO ENGINE ROOM HARNESS
75G	R	TO ENGINE ROOM HARNESS
76G	R/G	TO ENGINE ROOM HARNESS
77G	BG	TO ENGINE ROOM HARNESS

A
B
C
D
E
F
G
H
I
J
K
L
M
N
O
P

DLK

POWER DOOR LOCK SYSTEM

< WIRING DIAGRAM >

POWER DOOR LOCK SYSTEM CONNECTORS

Connector No.	M36
Connector Name	WIRE TO WIRE
Connector Type	TH80FDGY-CST6-TM4
Connector Color	GRAY

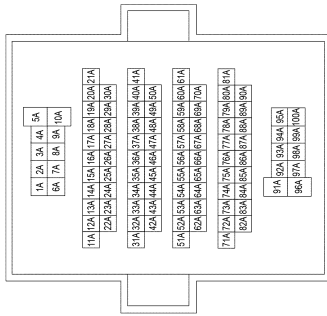

76A	SHIELD	TO BODY NO. 2 HARNESS
76A	R	TO BODY NO. 2 HARNESS
77A	L	TO BODY NO. 2 HARNESS
78A	SHIELD	TO BODY NO. 2 HARNESS
79A	GR	TO BODY NO. 2 HARNESS
80A	V	TO BODY NO. 2 HARNESS
81A	R	TO BODY NO. 2 HARNESS
82A	SHIELD	TO BODY NO. 2 HARNESS
83A	R	TO BODY NO. 2 HARNESS
84A	O	TO BODY NO. 2 HARNESS
85A	SHIELD	TO BODY NO. 2 HARNESS
86A	W	TO BODY NO. 2 HARNESS
87A	B	TO BODY NO. 2 HARNESS
88A	W	TO BODY NO. 2 HARNESS
89A	SHIELD	TO BODY NO. 2 HARNESS
90A	G	TO BODY NO. 2 HARNESS
91A	W/L	TO BODY NO. 2 HARNESS
92A	BR	TO BODY NO. 2 HARNESS
93A	L/Y	TO BODY NO. 2 HARNESS
94A	R/L	TO BODY NO. 2 HARNESS
95A	BR	TO BODY NO. 2 HARNESS
96A	R	TO BODY NO. 2 HARNESS
97A	LG	TO BODY NO. 2 HARNESS
98A	B/V	TO BODY NO. 2 HARNESS
99A	O/V	TO BODY NO. 2 HARNESS
100A	BR/W	TO BODY NO. 2 HARNESS

22A	G	TO BODY NO. 2 HARNESS
23A	Y	TO BODY NO. 2 HARNESS
24A	L	TO BODY NO. 2 HARNESS
25A	-	TO BODY NO. 2 HARNESS
26A	GR	TO BODY NO. 2 HARNESS
27A	LG	TO BODY NO. 2 HARNESS
28A	LG	TO BODY NO. 2 HARNESS
29A	GR	TO BODY NO. 2 HARNESS
30A	-	TO BODY NO. 2 HARNESS
31A	W/R	TO BODY NO. 2 HARNESS
32A	G/R	TO BODY NO. 2 HARNESS
33A	-	TO BODY NO. 2 HARNESS
34A	SHIELD	TO BODY NO. 2 HARNESS
35A	P	TO BODY NO. 2 HARNESS
36A	B	TO BODY NO. 2 HARNESS
37A	-	TO BODY NO. 2 HARNESS
38A	R/B	TO BODY NO. 2 HARNESS
39A	G/O	TO BODY NO. 2 HARNESS
40A	V	TO BODY NO. 2 HARNESS
41A	SHIELD	TO BODY NO. 2 HARNESS
42A	SHIELD	TO BODY NO. 2 HARNESS
43A	R	TO BODY NO. 2 HARNESS
44A	G	TO BODY NO. 2 HARNESS
45A	-	TO BODY NO. 2 HARNESS
46A	-	TO BODY NO. 2 HARNESS
47A	Y	TO BODY NO. 2 HARNESS
48A	R/W	TO BODY NO. 2 HARNESS
49A	R/L	TO BODY NO. 2 HARNESS
50A	B	TO BODY NO. 2 HARNESS
51A	-	TO BODY NO. 2 HARNESS
52A	-	TO BODY NO. 2 HARNESS
53A	-	TO BODY NO. 2 HARNESS
54A	-	TO BODY NO. 2 HARNESS
55A	-	TO BODY NO. 2 HARNESS
56A	-	TO BODY NO. 2 HARNESS
57A	-	TO BODY NO. 2 HARNESS
58A	-	TO BODY NO. 2 HARNESS
59A	-	TO BODY NO. 2 HARNESS
60A	G/W	TO BODY NO. 2 HARNESS
61A	-	TO BODY NO. 2 HARNESS
62A	-	TO BODY NO. 2 HARNESS
63A	-	TO BODY NO. 2 HARNESS
64A	-	TO BODY NO. 2 HARNESS
65A	-	TO BODY NO. 2 HARNESS
66A	-	TO BODY NO. 2 HARNESS
67A	-	TO BODY NO. 2 HARNESS
68A	Y/R	TO BODY NO. 2 HARNESS
69A	R/G	TO BODY NO. 2 HARNESS
70A	-	TO BODY NO. 2 HARNESS
71A	-	TO BODY NO. 2 HARNESS
72A	W	TO BODY NO. 2 HARNESS
73A	G	TO BODY NO. 2 HARNESS
74A	W	TO BODY NO. 2 HARNESS

Terminal No.	Color of Wire	Signal Name
1A	W	TO BODY NO. 2 HARNESS
2A	LG	TO BODY NO. 2 HARNESS
3A	V	TO BODY NO. 2 HARNESS
4A	SB	TO BODY NO. 2 HARNESS
5A	-	TO BODY NO. 2 HARNESS
6A	BG	TO BODY NO. 2 HARNESS - (WITH CLIMATE CONTROLLED SEAT)
6A	LG	TO BODY NO. 2 HARNESS - (WITHOUT CLIMATE CONTROLLED SEAT)
7A	W	TO BODY NO. 2 HARNESS
8A	B	TO BODY NO. 2 HARNESS
9A	L/B	TO BODY NO. 2 HARNESS
10A	W	TO BODY NO. 2 HARNESS
11A	R	TO BODY NO. 2 HARNESS
12A	BR	TO BODY NO. 2 HARNESS
13A	G	TO BODY NO. 2 HARNESS
14A	P/G	TO BODY NO. 2 HARNESS
15A	O	TO BODY NO. 2 HARNESS
16A	O/L	TO BODY NO. 2 HARNESS
17A	L	TO BODY NO. 2 HARNESS
18A	Y	TO BODY NO. 2 HARNESS
19A	B/W	TO BODY NO. 2 HARNESS
20A	BR/Y	TO BODY NO. 2 HARNESS
21A	BG	TO BODY NO. 2 HARNESS

AAKIA37956B

POWER DOOR LOCK SYSTEM

< WIRING DIAGRAM >

POWER DOOR LOCK SYSTEM CONNECTORS

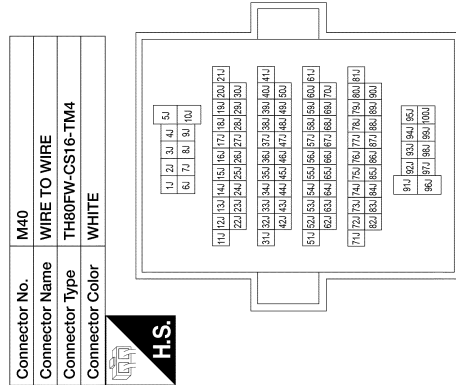

Terminal No.	Color of Wire	Signal Name
28J	L	TO BODY HARNESS
28J	G/O	TO BODY HARNESS
30J	SB	TO BODY HARNESS
31J	L/G	TO BODY HARNESS
32J	R	TO BODY HARNESS
33J	BG	TO BODY HARNESS
34J	Y	TO BODY HARNESS
35J	P	TO BODY HARNESS
36J	G/R	TO BODY HARNESS
37J	LG	TO BODY HARNESS
38J	SB	TO BODY HARNESS
39J	Y	TO BODY HARNESS
40J	SB	TO BODY HARNESS
41J	L	TO BODY HARNESS
42J	L	TO BODY HARNESS
43J	W	TO BODY HARNESS
44J	BR	TO BODY HARNESS
45J	BG	TO BODY HARNESS
46J	P	TO BODY HARNESS
47J	O	TO BODY HARNESS
48J	V	TO BODY HARNESS
49J	BR	TO BODY HARNESS
50J	G/W	TO BODY HARNESS
51J	-	TO BODY HARNESS
52J	SHIELD	TO BODY HARNESS
53J	R	TO BODY HARNESS
54J	L	TO BODY HARNESS
55J	R	TO BODY HARNESS
56J	W	TO BODY HARNESS
57J	R	TO BODY HARNESS
58J	B	TO BODY HARNESS
59J	-	TO BODY HARNESS
60J	SHIELD	TO BODY HARNESS
61J	G	TO BODY HARNESS
62J	-	TO BODY HARNESS
63J	R/W	TO BODY HARNESS
64J	L/W	TO BODY HARNESS
65J	SHIELD	TO BODY HARNESS
66J	B	TO BODY HARNESS
67J	SHIELD	TO BODY HARNESS
68J	W	TO BODY HARNESS
69J	SHIELD	TO BODY HARNESS
70J	B/R	TO BODY HARNESS
71J	L/W	TO BODY HARNESS
72J	-	TO BODY HARNESS
73J	-	TO BODY HARNESS
74J	SHIELD	TO BODY HARNESS
75J	R	TO BODY HARNESS
76J	O	TO BODY HARNESS
77J	SHIELD	TO BODY HARNESS
78J	W	TO BODY HARNESS
79J	B	TO BODY HARNESS
80J	W	TO BODY HARNESS

Terminal No.	Color of Wire	Signal Name
1J	G	TO BODY HARNESS
2J	R/Y	TO BODY HARNESS
3J	L	TO BODY HARNESS
4J	L/B	TO BODY HARNESS
5J	B	TO BODY HARNESS
6J	BR	TO BODY HARNESS
7J	BG	TO BODY HARNESS
8J	SB	TO BODY HARNESS
9J	BR	TO BODY HARNESS
10J	R	TO BODY HARNESS
11J	O/B	TO BODY HARNESS
12J	L	TO BODY HARNESS
13J	W	TO BODY HARNESS
14J	Y	TO BODY HARNESS
15J	-	TO BODY HARNESS
16J	R	TO BODY HARNESS
17J	G	TO BODY HARNESS
18J	SB	TO BODY HARNESS
19J	O	TO BODY HARNESS
20J	O/B	TO BODY HARNESS
21J	Y	TO BODY HARNESS
22J	P	TO BODY HARNESS
23J	W	TO BODY HARNESS
24J	W/R	TO BODY HARNESS
25J	P	TO BODY HARNESS
26J	L	TO BODY HARNESS
27J	R	TO BODY HARNESS

AAK13796GB

Terminal No.	Color of Wire	Signal Name
81J	SHIELD	TO BODY HARNESS
82J	L/R	TO BODY HARNESS
83J	-	TO BODY HARNESS
84J	-	TO BODY HARNESS
85J	W	TO BODY HARNESS
86J	G	TO BODY HARNESS
87J	W	TO BODY HARNESS
88J	SHIELD	TO BODY HARNESS
89J	R	TO BODY HARNESS
90J	L	TO BODY HARNESS
91J	L/B	TO BODY HARNESS
92J	SB	TO BODY HARNESS
93J	B	TO BODY HARNESS
94J	LG	TO BODY HARNESS
95J	L	TO BODY HARNESS
96J	G	TO BODY HARNESS
97J	B/Y	TO BODY HARNESS
98J	L/B	TO BODY HARNESS
99J	W/L	TO BODY HARNESS
100J	Y	TO BODY HARNESS

Connector No.	M74
Connector Name	WIRE TO WIRE
Connector Type	TH32MW-NH
Connector Color	WHITE

H.S.

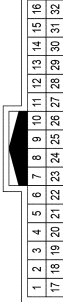

Terminal No.	Color of Wire	Signal Name
19	G	TO FRONT DOOR RH HARNESS
20	V/W	TO FRONT DOOR RH HARNESS - (WITHOUT DRIVE POSITIONER)
20	G/R	TO FRONT DOOR RH HARNESS - (WITH DRIVE POSITIONER)
21	-	TO FRONT DOOR RH HARNESS
22	-	TO FRONT DOOR RH HARNESS
23	O	TO FRONT DOOR RH HARNESS
24	R	TO FRONT DOOR RH HARNESS
25	SHIELD	TO FRONT DOOR RH HARNESS
26	W	TO FRONT DOOR RH HARNESS
27	BG	TO FRONT DOOR RH HARNESS
28	G	TO FRONT DOOR RH HARNESS
29	L/G/B	TO FRONT DOOR RH HARNESS
30	-	TO FRONT DOOR RH HARNESS
31	-	TO FRONT DOOR RH HARNESS
32	-	TO FRONT DOOR RH HARNESS

Connector No.	M75
Connector Name	WIRE TO WIRE
Connector Type	NS10MW-CS
Connector Color	WHITE

H.S.

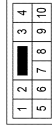

Terminal No.	Color of Wire	Signal Name
1	B/W	TO FRONT DOOR RH HARNESS
2	B	TO FRONT DOOR RH HARNESS
3	W/L	TO FRONT DOOR RH HARNESS
4	V	TO FRONT DOOR RH HARNESS
5	W/B	TO FRONT DOOR RH HARNESS
6	G/Y	TO FRONT DOOR RH HARNESS
7	W/B	TO FRONT DOOR RH HARNESS
8	L/B	TO FRONT DOOR RH HARNESS
9	G/Y	TO FRONT DOOR RH HARNESS
10	-	TO FRONT DOOR RH HARNESS

Terminal No.	Color of Wire	Signal Name
1	BR	TO FRONT DOOR RH HARNESS
2	V	TO FRONT DOOR RH HARNESS
3	BR	TO FRONT DOOR RH HARNESS
4	L	TO FRONT DOOR RH HARNESS
5	-	TO FRONT DOOR RH HARNESS
6	R/W	TO FRONT DOOR RH HARNESS
7	R/G	TO FRONT DOOR RH HARNESS
8	B	TO FRONT DOOR RH HARNESS
9	W	TO FRONT DOOR RH HARNESS
10	Y	TO FRONT DOOR RH HARNESS
11	LG	TO FRONT DOOR RH HARNESS
12	L	TO FRONT DOOR RH HARNESS
13	Y/W	TO FRONT DOOR RH HARNESS
14	W/L	TO FRONT DOOR RH HARNESS
15	V/R	TO FRONT DOOR RH HARNESS
16	L/W	TO FRONT DOOR RH HARNESS
17	SB	TO FRONT DOOR RH HARNESS
18	Y	TO FRONT DOOR RH HARNESS

A B C D E F G H I J L M N O P

DLK

POWER DOOR LOCK SYSTEM

< WIRING DIAGRAM >

POWER DOOR LOCK SYSTEM CONNECTORS

Connector No.	M81
Connector Name	BCM (BODY CONTROL MODULE)
Connector Type	FEA09FW-FHAG-SA
Connector Color	WHITE



137	136	135	134	133	132	131	130	129
143	142	141	140	139	138			

Terminal No.	Color of Wire	Signal Name
129	R/G	BATTERY SAVER OUT
130	LG	SUPER LOCK/DOOR UNLOCK AS
131	W	BAT BCM FUSE
132	Y	DOOR LOCK AS/RR/RL
133	BR	DOOR UNLOCK AS/RR/RL
134	B	GND2
135	O	DOOR LOCK DR/AS/FL
136	L	ROOM LAMP CONT
137	V	DOOR UNLOCK DR/AS/FL
138	V	BAT REAR DOOR
139	W	BAT-POWER F/L
140	LG	P/W POWER SUPPLY IGN
141	V	P/W POWER SUPPLY BAT
142	Y	BAT FRONT DOOR
143	B	GND1

AAKIA3797GB

DIAGNOSIS AND REPAIR WORK FLOW

< BASIC INSPECTION >

BASIC INSPECTION

DIAGNOSIS AND REPAIR WORK FLOW

Work Flow

INFOID:000000013037035

OVERALL SEQUENCE

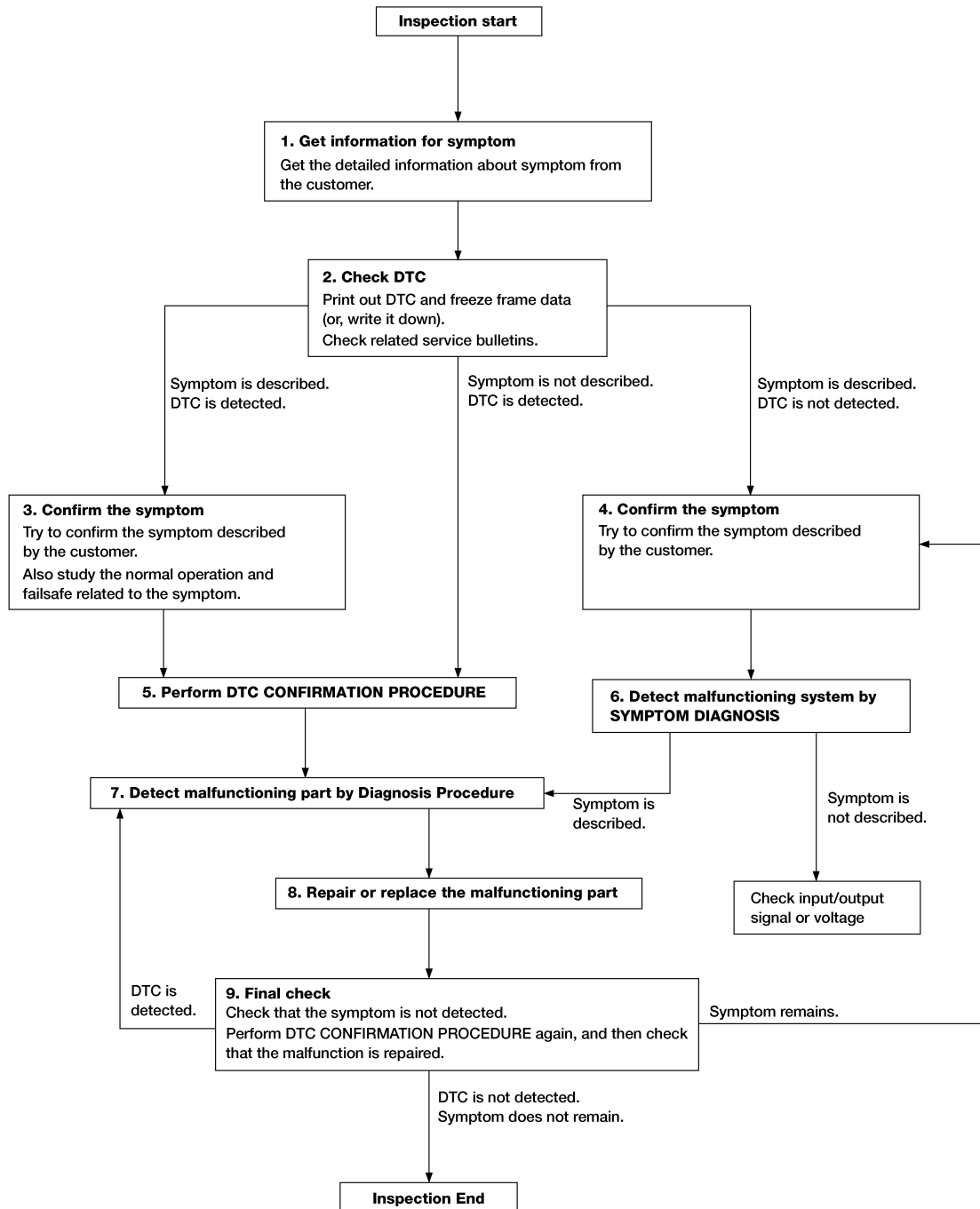

A
B
C
D
E
F
G
H
I
J
L
M
N
O
P

DLK

DETAILED FLOW

Revision: March 2016

DLK-69

ALAI0158GB

2016 Titan NAM

DIAGNOSIS AND REPAIR WORK FLOW

< BASIC INSPECTION >

1. GET INFORMATION FOR SYMPTOM

1. Get detailed information from the customer about the symptom (the condition and the environment when the incident/malfunction occurs).
2. Check operation condition of the function that is malfunctioning.

>> GO TO 2.

2. CHECK DTC

1. Check DTC.
2. Perform the following procedure if DTC is detected.
 - Record DTC and freeze frame data. (Print them out using CONSULT.)
 - Erase DTC.
 - Study the relationship between the cause detected by DTC and the symptom described by the customer.
3. Check related service bulletins for information.

Are any symptoms described and is any DTC detected?

Symptom is described, DTC is detected.>> GO TO 3.

Symptom is described, DTC is not detected.>> GO TO 4.

Symptom is not described, DTC is detected.>> GO TO 5.

3. CONFIRM THE SYMPTOM

Try to confirm the symptom described by the customer.

Also study the normal operation and fail-safe related to the symptom.

Verify relation between the symptom and the condition when the symptom is detected.

>> GO TO 5.

4. CONFIRM THE SYMPTOM

Try to confirm the symptom described by the customer.

Verify relation between the symptom and the condition when the symptom is detected.

>> GO TO 6.

5. PERFORM DTC CONFIRMATION PROCEDURE

Perform DTC CONFIRMATION PROCEDURE for the detected DTC and then check that DTC is detected again. At this time, always connect CONSULT to the vehicle and check self diagnostic results in real time.

If two or more DTCs are detected, refer to [BCS-51. "DTC Inspection Priority Chart"](#) (BCM) and determine trouble diagnosis order.

NOTE:

- Freeze frame data is useful if the DTC is not detected.
- Perform Component Function Check if DTC CONFIRMATION PROCEDURE is not included in Service Manual. This simplified check procedure is an effective alternative though DTC cannot be detected during this check.

If the result of Component Function Check is NG, it is the same as the detection of a DTC by DTC CONFIRMATION PROCEDURE.

Is DTC detected?

YES >> GO TO 7.

NO >> Check according to [GI-43. "Intermittent Incident"](#).

6. DETECT MALFUNCTIONING SYSTEM BY SYMPTOM DIAGNOSIS

Detect malfunctioning system according to SYMPTOM DIAGNOSIS based on the confirmed symptom in step 4, and determine the trouble diagnosis order based on possible causes and symptom.

Is the symptom described?

YES >> GO TO 7.

NO >> Monitor input data from related sensors or check voltage of related module terminals using CONSULT.

7. DETECT MALFUNCTIONING PART BY DIAGNOSIS PROCEDURE

DIAGNOSIS AND REPAIR WORK FLOW

< BASIC INSPECTION >

Inspect according to Diagnosis Procedure of the system.

Is malfunctioning part detected?

YES >> GO TO 8.

NO >> Check according to [GI-43. "Intermittent Incident"](#).

8. REPAIR OR REPLACE THE MALFUNCTIONING PART

1. Repair or replace the malfunctioning part.
2. Reconnect parts or connectors disconnected during Diagnosis Procedure again after repair and replacement.
3. Check DTC. If DTC is detected, erase it.

>> GO TO 9.

9. FINAL CHECK

When DTC is detected in step 2, perform DTC CONFIRMATION PROCEDURE again, and then check that the malfunction is repaired securely.

When symptom is described by the customer, refer to confirmed symptom in step 3 or 4, and check that the symptom is not detected.

Is DTC detected and does symptom remain?

YES-1 >> DTC is detected: GO TO 7.

YES-2 >> Symptom remains: GO TO 4.

NO >> Before returning the vehicle to the customer, always erase DTC.

A
B
C
D
E
F
G
H
I
J
L
M
N
O
P

DLK

ADDITIONAL SERVICE WHEN REPLACING BCM

< BASIC INSPECTION >

ADDITIONAL SERVICE WHEN REPLACING BCM

Description

INFOID:000000013037038

Perform the system initialization when replacing BCM, replacing Intelligent Key or registering an additional Intelligent Key.

Work Procedure

INFOID:000000013037039

Refer to the CONSULT Immobilizer mode and follow the on-screen instructions.

U1000 CAN COMM CIRCUIT

< DTC/CIRCUIT DIAGNOSIS >

DTC/CIRCUIT DIAGNOSIS

U1000 CAN COMM CIRCUIT

DTC Description

INFOID:0000000013052210

Description

CAN (Controller Area Network) is a serial communication line for real time applications. It is an on-vehicle multiplex communication line with high data communication speed and excellent error detection ability. Modern vehicles are equipped with many electronic control units and each control unit shares information and links with other control units during operation (not independent). In CAN communication, control units are connected with 2 communication lines (CAN H-line, CAN L-line) allowing a high rate of information transmission with less wiring. Each control unit transmits/receives data but selectively reads required data only. CAN Communication Signal Chart. Refer to [LAN-70, "CAN COMMUNICATION SYSTEM : CAN Communication Signal Chart"](#).

DTC DETECTION LOGIC

DTC No.	CONSULT screen terms (Trouble diagnosis content)	DTC Detection Condition	
		Diagnosis condition	When ignition switch is ON.
U1000	CAN COMM CIRCUIT (CAN communication circuit)	Signal (terminal)	—
		Threshold	—
		Diagnosis delay time	2 seconds or more

POSSIBLE CAUSE

CAN communication system

FAIL-SAFE

—

Diagnosis Procedure

INFOID:0000000013052211

1. SELF DIAGNOSTIC RESULT

ⓂCONSULT

1. Turn ignition switch ON and wait for 2 seconds or more.
2. Check "Self Diagnostic Result" mode of "BCM".
3. Check DTC.

Is DTC "U1000" displayed?

YES >> Refer to [LAN-51, "Trouble Diagnosis Flow Chart"](#).

NO-1 >> To check malfunction symptom before repair: Refer to [GI-43, "Intermittent Incident"](#).

NO-2 >> Confirmation after repair: Inspection End.

A
B
C
D
E
F
G
H
I
J
DLK
L
M
N
O
P

U1010 CONTROL UNIT (CAN)

< DTC/CIRCUIT DIAGNOSIS >

U1010 CONTROL UNIT (CAN)

DTC Description

INFOID:000000013052220

DTC DETECTION LOGIC

DTC No.	CONSULT screen terms (Trouble diagnosis content)	DTC Detection Condition	
		Diagnosis condition	When ignition switch is ON.
U1010	CONTROL UNIT(CAN) (Control unit)	Signal (terminal)	—
		Threshold	—
		Diagnosis delay time	2 seconds or more

POSSIBLE CAUSE

- BCM

FAIL-SAFE

—

Diagnosis Procedure

INFOID:000000013052221

1. REPLACE BCM

When DTC U1010 is detected, replace BCM.

>> Replace BCM. Refer to [BCS-79. "Removal and Installation"](#).

B2621 INSIDE ANTENNA

< DTC/CIRCUIT DIAGNOSIS >

B2621 INSIDE ANTENNA

DTC Description

INFOID:000000013037086

DTC DETECTION LOGIC

DTC No.	CONSULT screen terms (Trouble diagnosis content)	DTC Detection Condition	
		Diagnosis condition	When ignition switch is ON.
B2621	INSIDE ANTENNA	Signal (terminal)	BCM terminals 123,124
		Threshold	An excessive high or low voltage from inside antenna (instrument center) is sent to BCM
		Diagnosis delay time	—

POSSIBLE CAUSE

- Inside key antenna (instrument center)
- Harness or connector
[Inside key antenna (instrument center) circuit is open or shorted]

FAIL-SAFE

—

DTC CONFIRMATION PROCEDURE

1. PERFORM DTC CONFIRMATION PROCEDURE

Ⓜ CONSULT

1. Select "INTELLIGENT KEY" of "BCM".
2. Select "INSIDE ANT DIAGNOSIS" in "Work support" mode.
3. Perform inside key antenna ("INSIDE ANT DIAGNOSIS") in "Work support" mode of "INTELLIGENT KEY".
4. Check BCM for DTC.

Is inside key antenna DTC detected?

- YES >> Refer to [DLK-75. "Diagnosis Procedure"](#).
- NO >> Inside key antenna (instrument center) is OK.

Diagnosis Procedure

INFOID:000000013037087

Regarding Wiring Diagram information, refer to [DLK-39. "Wiring Diagram"](#).

1. CHECK INSIDE KEY ANTENNA INPUT SIGNAL 1

1. Turn ignition switch OFF.
2. Check signal between BCM harness connector and ground using oscilloscope.

B2621 INSIDE ANTENNA

< DTC/CIRCUIT DIAGNOSIS >

(+)		(-)	Condition	Signal (Reference value)
BCM				
Connector	Terminal			
M80	123, 124	Ground	When Intelligent Key is in the antenna detection area.	<p style="text-align: right;">JMKIA3839GB</p>
			When Intelligent Key is not in the antenna detection area.	<p style="text-align: right;">JMKIA5951GB</p>

Is the inspection result normal?

YES >> Replace BCM. Refer to [BCS-79, "Removal and Installation"](#).

NO >> GO TO 2.

2. CHECK INSIDE KEY ANTENNA CIRCUIT

1. Disconnect BCM connector and inside key antenna (instrument center) connector.
2. Check continuity between BCM harness connector and inside key antenna (instrument center) harness connector.

BCM		Inside key antenna (instrument center)		Continuity
Connector	Terminal	Connector	Terminal	
M80	123	M84	1	Yes
	124		2	

3. Check continuity between BCM harness connector and ground.

BCM		Ground	Continuity
Connector	Terminal		
M80	123		No
	124		

Is the inspection result normal?

YES >> GO TO 3.

NO >> Repair or replace harness.

3. CHECK INSIDE KEY ANTENNA INPUT SIGNAL 2

1. Replace inside key antenna (instrument center) (New antenna or other antenna).
2. Connect BCM connector and inside key antenna (instrument center) connector.
3. Check signal between BCM harness connector and ground using oscilloscope.

B2621 INSIDE ANTENNA

< DTC/CIRCUIT DIAGNOSIS >

(+)		(-)	Condition	Signal (Reference value)
BCM				
Connector	Terminal			
M80	123, 124	Ground	When Intelligent Key is in the antenna detection area.	
			When Intelligent Key is not in the antenna detection area.	

Is the inspection result normal?

- YES >> Replace inside key antenna (instrument center).
- NO >> Replace BCM. Refer to [BCS-79. "Removal and Installation"](#).

A
B
C
D
E
F
G
H
I
J
L
M
N
O
P

DLK

B2622 INSIDE ANTENNA

< DTC/CIRCUIT DIAGNOSIS >

B2622 INSIDE ANTENNA

DTC Description

INFOID:000000013037088

DTC DETECTION LOGIC

DTC No.	CONSULT screen terms (Trouble diagnosis content)	DTC Detection Condition	
B2622	INSIDE ANTENNA	Diagnosis condition	When ignition switch is ON.
		Signal (terminal)	BCM terminals 116, 128
		Threshold	An excessive high or low voltage from inside antenna (console) is sent to BCM
		Diagnosis delay time	—

POSSIBLE CAUSE

- Inside key antenna (console)
- Harness or connector
[Inside key antenna (console) circuit is open or shorted]

FAIL-SAFE

—

DTC CONFIRMATION PROCEDURE

1. PERFORM DTC CONFIRMATION PROCEDURE

Ⓜ CONSULT

1. Select "INTELLIGENT KEY" of "BCM".
2. Select "INSIDE ANT DIAGNOSIS" in "Work support" mode.
3. Perform inside key antenna ("INSIDE ANT DIAGNOSIS") in "Work support" mode of "INTELLIGENT KEY".
4. Check BCM for DTC.

Is inside key antenna DTC detected?

- YES >> Refer to [DLK-78, "Diagnosis Procedure"](#).
- NO >> Inside key antenna (console) is OK.

Diagnosis Procedure

INFOID:000000013037089

Regarding Wiring Diagram information, refer to [DLK-39, "Wiring Diagram"](#).

1. CHECK INSIDE KEY ANTENNA INPUT SIGNAL 1

1. Turn ignition switch OFF.
2. Check signal between BCM harness connector and ground using oscilloscope.

B2622 INSIDE ANTENNA

< DTC/CIRCUIT DIAGNOSIS >

(+)		(-)	Condition	Signal (Reference value)
BCM				
Connector	Terminal			
M80	116, 128	Ground	When Intelligent Key is in the antenna detection area.	
			When Intelligent Key is not in the antenna detection area.	

Is the inspection result normal?

YES >> Replace BCM. Refer to [BCS-79, "Removal and Installation"](#).

NO >> GO TO 2.

2. CHECK INSIDE KEY ANTENNA CIRCUIT

1. Disconnect BCM connector and inside key antenna (console) connector.
2. Check continuity between BCM harness connector and inside key antenna (console) harness connector.

BCM		Inside key antenna (console)		Continuity
Connector	Terminal	Connector	Terminal	
M80	116	M85	1	Yes
	128		2	

3. Check continuity between BCM harness connector and ground.

BCM		Ground	Continuity
Connector	Terminal		
M80	116		Ground
	128		

Is the inspection result normal?

YES >> GO TO 3.

NO >> Repair or replace harness.

3. CHECK INSIDE KEY ANTENNA INPUT SIGNAL 2

1. Replace inside key antenna (console) (New antenna or other antenna).
2. Connect BCM connector and inside key antenna (console) connector.
3. Check signal between BCM harness connector and ground using oscilloscope.

B2622 INSIDE ANTENNA

< DTC/CIRCUIT DIAGNOSIS >

(+)		(-)	Condition	Signal (Reference value)
BCM				
Connector	Terminal			
M80	116, 128	Ground	When Intelligent Key is in the antenna detection area.	<p style="text-align: right; font-size: small;">JMKIA3839GB</p>
			When Intelligent Key is not in the antenna detection area.	<p style="text-align: right; font-size: small;">JMKIA5951GB</p>

Is the inspection result normal?

- YES >> Replace inside key antenna (console). Refer to [DLK-184, "CONSOLE : Removal and Installation"](#).
- NO >> Replace BCM. Refer to [BCS-79, "Removal and Installation"](#).

B26FD SHIFT LOCK SOLENOID

< DTC/CIRCUIT DIAGNOSIS >

B26FD SHIFT LOCK SOLENOID

DTC Description

INFOID:0000000013052230

DTC DETECTION LOGIC

DTC No.	CONSULT screen terms (Trouble diagnosis content)	DTC Detection Condition	
B26FD	SHIFT LOCK SOLENOID	Diagnosis condition	When ignition switch is ON.
		Signal (terminal)	BCM terminal 108
		Threshold	BCM shift lock solenoid output control is OFF, but shift lock solenoid output feedback is ON
		Diagnosis delay time	1 second

POSSIBLE CAUSE

- Shift lock solenoid
- Harness or connector
- Shift lock solenoid circuit is open or shorted

FAIL-SAFE

—

DTC CONFIRMATION PROCEDURE

1. PERFORM DTC CONFIRMATION PROCEDURE

Ⓜ CONSULT

1. Turn ignition switch ON.
2. Check "Self Diagnostic Result" mode of "BCM".

Is DTC detected?

- YES >> Refer to [DLK-81. "Diagnosis Procedure"](#).
- NO >> Shift lock solenoid is OK.

Diagnosis Procedure

INFOID:0000000013052231

Regarding Wiring Diagram information, refer to [DLK-39. "Wiring Diagram"](#).

1. CHECK HARNESS BETWEEN BCM AND A/T SHIFT SELECTOR FOR OPEN

1. Disconnect A/T shift selector and BCM.
2. Check continuity between BCM and A/T shift selector.

BCM		A/T shift selector		Continuity
Connector	Terminal	Connector	Terminal	
M18	108	M68	3	Yes

Is the inspection result normal?

- YES >> GO TO 2.
- NO >> Repair or replace damaged parts.

2. CHECK HARNESS BETWEEN BCM AND A/T SHIFT SELECTOR FOR SHORT CIRCUIT

Check continuity between BCM and ground.

BCM		Ground	Continuity
Connector	Terminal		
M18	108		No

A
B
C
D
E
F
G
H
I
J
L
M
N
O
P

DLK

B26FD SHIFT LOCK SOLENOID

< DTC/CIRCUIT DIAGNOSIS >

Is the inspection result normal?

YES >> GO TO 3.

NO >> Repair or replace damaged parts.

3. CHECK GROUND CIRCUIT (A/T SHIFT SELECTOR)

Check continuity between A/T shift selector and ground.

A/T shift selector		Ground	Continuity
Connector	Terminal		
M68	1		Yes

Is the inspection result normal?

YES >> Replace shift lock solenoid. Refer to [TM-218, "Exploded View"](#).

NO >> Repair or replace damaged parts.

B26FE HOOD SWITCH

< DTC/CIRCUIT DIAGNOSIS >

B26FE HOOD SWITCH

DTC Description

INFOID:000000013037094

DTC DETECTION LOGIC

NOTE:

- If DTC B26FE is displayed with DTC U1000, first perform the trouble diagnosis for DTC U1000. Refer to [BCS-67, "DTC Description"](#).
- If DTC B26FE is displayed with DTC U1010, first perform the trouble diagnosis for DTC U1010. Refer to [BCS-68, "DTC Description"](#).

DTC No.	CONSULT screen terms (Trouble diagnosis content)	DTC Detection Condition	
		Diagnosis condition	When ignition switch is ON.
B26FE	HOOD SWITCH	Signal (terminal)	IPDM E/R terminals 71,46
		Threshold	BCM detects that the hood switch input is malfunctioning
		Diagnosis delay time	3 seconds

POSSIBLE CAUSE

- Hood switch
- Harness or connector
[hood switch circuit is open or shorted]

FAIL-SAFE

DTC CONFIRMATION PROCEDURE

1. PERFORM DTC CONFIRMATION PROCEDURE

CONSULT

1. Turn ignition switch ON.
2. Check "Self Diagnostic Result" mode of "BCM".

Is DTC detected?

- YES >> Refer to [DLK-83, "Diagnosis Procedure"](#).
- NO >> Hood switch is OK.

Diagnosis Procedure

INFOID:000000013037095

Regarding Wiring Diagram information, refer to [DLK-39, "Wiring Diagram"](#).

1. CHECK HOOD SWITCH SIGNAL CIRCUITS

1. Turn ignition switch OFF.
2. Disconnect hood switch connector.
3. Check voltage between hood switch harness connector and ground.

(+)		(-)	Voltage (Approx.)
Hood switch			
Connector	Terminal		
E94	3	Ground	Battery voltage
	2		

Is the inspection result normal?

- YES >> GO TO 3.
- NO >> GO TO 2.

B26FE HOOD SWITCH

< DTC/CIRCUIT DIAGNOSIS >

2. CHECK HOOD SWITCH SIGNAL CIRCUITS

1. Disconnect IPDM E/R connector.
2. Check continuity between IPDM E/R harness connector and hood switch harness connector.

IPDM E/R		Hood switch		Continuity
Connector	Terminal	Connector	Terminal	
E130	71	E94	3	Yes
E122	46		2	

3. Check continuity between IPDM E/R harness connector and ground.

IPDM E/R		Ground	Continuity
Connector	Terminal		
E130	71		No
E122	46		

Is the inspection result normal?

YES >> Replace IPDM E/R. Refer to [PCS-43, "Removal and Installation of IPDM E/R"](#).

NO >> Repair or replace harness.

3. CHECK HOOD SWITCH GROUND CIRCUIT

Check continuity between hood switch harness connector and ground.

Hood switch		Ground	Continuity
Connector	Terminal		
E94	1		Yes

Is the inspection result normal?

YES >> GO TO 4.

NO >> Repair or replace harness.

4. CHECK HOOD SWITCH

Refer to [DLK-84, "Component Inspection"](#).

Is the inspection result normal?

YES >> GO TO 5.

NO >> Replace hood switch. Refer to [DLK-165, "HOOD LOCK : Removal and Installation"](#).

5. CHECK BCM CONFIGURATION

Refer to [BCS-64, "CONFIGURATION \(BCM\) : Configuration List"](#).

>> Inspection End.

Component Inspection

INFOID:000000013037096

1. CHECK HOOD SWITCH

1. Turn ignition switch OFF.
2. Disconnect hood switch connector.
3. Check continuity between hood switch terminals.

Hood switch		Condition	Continuity	
Terminal				
3	1	Hood switch	Press	Yes
		Release	No	
2		Press	No	
		Release	Yes	

B26FE HOOD SWITCH

< DTC/CIRCUIT DIAGNOSIS >

Is the inspection result normal?

YES >> Inspection End.

NO >> Replace hood switch. Refer to [DLK-165. "HOOD LOCK : Removal and Installation"](#).

A

B

C

D

E

F

G

H

I

J

DLK

L

M

N

O

P

B26FF REMOTE KEYLESS ENTRY RECEIVER

< DTC/CIRCUIT DIAGNOSIS >

B26FF REMOTE KEYLESS ENTRY RECEIVER

DTC Description

INFOID:000000013037097

DTC DETECTION LOGIC

DTC No.	CONSULT screen terms (Trouble diagnosis content)	DTC Detection Condition	
B26FF	INTELLIGENT TUNER COMMUNICATION FAIL	Diagnosis condition	When ignition switch is ON.
		Signal (terminal)	BCM terminal 119
		Threshold	Inactive communication between BCM and remote keyless entry receiver
		Diagnosis delay time	—

POSSIBLE CAUSE

- Remote keyless entry receiver
- Harness or connector
- BCM

FAIL-SAFE

—

DTC CONFIRMATION PROCEDURE

1. PERFORM DTC CONFIRMATION PROCEDURE

ⓐ CONSULT

1. Turn ignition switch ON.
2. Check DTC in "Self Diagnostic Result" mode of "BCM".

Is DTC detected?

- YES >> Refer to [DLK-86, "Diagnosis Procedure"](#).
- NO >> Inspection End.

Diagnosis Procedure

INFOID:000000013037098

Regarding Wiring Diagram information, refer to [DLK-39, "Wiring Diagram"](#).

1. CHECK REMOTE KEYLESS ENTRY RECEIVER OUTPUT SIGNAL

1. Turn ignition switch OFF.
2. Check signal between BCM harness connector and ground using oscilloscope.

B26FF REMOTE KEYLESS ENTRY RECEIVER

< DTC/CIRCUIT DIAGNOSIS >

(+)		(-)	Condition	Signal (Reference value)
BCM				
Connector	Terminal			
M80	119	Ground	Standby state	
			Press the Intelligent Key lock or unlock button.	

Is the inspection result normal?

YES >> Replace BCM. Refer to [BCS-79, "Removal and Installation"](#).

NO >> GO TO 2.

2.CHECK REMOTE KEYLESS ENTRY RECEIVER CIRCUIT 1

1. Disconnect BCM and remote keyless entry receiver connectors.
2. Check continuity between BCM harness connector and remote keyless entry receiver harness connector.

BCM		Remote keyless entry receiver		Continuity
Connector	Terminal	Connector	Terminal	
M80	119	M86	2	Yes

3. Check continuity between BCM harness connector and ground.

(+)		(-)	Continuity
BCM			
Connector	Terminal		
M80	119	Ground	No

Is the inspection result normal?

YES >> GO TO 3.

NO >> Repair or replace harness.

3.CHECK REMOTE KEYLESS ENTRY RECEIVER POWER SUPPLY

Check voltage between remote keyless entry receiver harness connector and ground.

(+)		(-)	Voltage (Approx)
Remote keyless entry receiver			
Connector	Terminal		
M86	1	Ground	Battery voltage

Is the inspection result normal?

YES >> GO TO 4.

NO-1 >> Check 5A fuse No. 9 [located in fuse block J/B].

NO-2 >> Repair or replace harness between remote keyless entry receiver and 5A fuse No. 9.

4.CHECK REMOTE KEYLESS ENTRY RECEIVER GROUND CIRCUIT

B26FF REMOTE KEYLESS ENTRY RECEIVER

< DTC/CIRCUIT DIAGNOSIS >

Check continuity between remote keyless entry receiver harness connector and ground.

Remote keyless entry receiver		Ground	Continuity
Connector	Terminal		
M86	3		Yes

Is the inspection result normal?

- YES >> Replace remote keyless entry receiver. Refer to [DLK-188, "Removal and Installation"](#).
NO >> Repair or replace harness.

POWER SUPPLY AND GROUND CIRCUIT

< DTC/CIRCUIT DIAGNOSIS >

POWER SUPPLY AND GROUND CIRCUIT

BCM

BCM : Diagnosis Procedure

INFOID:0000000013052247

Regarding Wiring Diagram information, refer to [BCS-54, "Wiring Diagram"](#).

1. CHECK FUSE AND FUSIBLE LINK

Check that the following fuse and fusible link are not blown.

Signal name	Fuse and fusible link No.	
	Cummins 5.0L	VK56VD
Fusible link battery power	R (50A)	N (50A)
BCM battery fuse	1 (10A)	1 (10A)

Is the fuse or fusible link blown?

YES >> Replace the blown fuse or fusible link after repairing the affected circuit.

NO >> GO TO 2.

2. CHECK POWER SUPPLY CIRCUIT

1. Disconnect BCM connector M81.

2. Check voltage between BCM connector M81 terminals 131, 139 and ground.

BCM		Ground	Voltage (Approx.)
Connector	Terminal		
M81	131	(—)	Battery voltage
	139		

Is the inspection result normal?

YES >> GO TO 3.

NO >> Repair or replace harness or connectors.

3. CHECK GROUND CIRCUIT

Check continuity between BCM connector M81 terminals 134, 143 and ground.

BCM		Ground	Continuity
Connector	Terminal		
M81	134	—	Yes
	143		

Is the inspection result normal?

YES >> Inspection End.

NO >> Repair or replace harness or connectors.

B2626 OUTSIDE ANTENNA

< DTC/CIRCUIT DIAGNOSIS >

B2626 OUTSIDE ANTENNA

DTC Description

INFOID:000000013037101

DTC DETECTION LOGIC

DTC No.	CONSULT screen terms (Trouble diagnosis content)	DTC Detection Condition	
		Diagnosis condition	When ignition switch is ON.
B2626	OUTSIDE ANTENNA (Outside antenna)	Signal (terminal)	BCM terminals 114,115
		Threshold	An excessive high or low voltage from outside key antenna RH is sent to BCM
		Diagnosis delay time	—

POSSIBLE CAUSE

- BCM
- Outside key antenna RH
- Harness or connector (Outside key antenna RH circuit is open or shorted.)

FAIL-SAFE

—

DTC CONFIRMATION PROCEDURE

1. PERFORM DTC CONFIRMATION PROCEDURE

Ⓟ CONSULT

1. Turn ignition switch ON.
2. Check "Self Diagnostic Result" mode of "BCM".

Is DTC detected?

- YES >> Refer to [DLK-90, "Diagnosis Procedure"](#).
- NO-1 >> To check malfunction symptom before repair: Refer to [GI-43, "Intermittent Incident"](#).
- NO-2 >> Confirmation after repair: Inspection End.

Diagnosis Procedure

INFOID:000000013037102

Regarding Wiring Diagram information, refer to [DLK-39, "Wiring Diagram"](#).

1. CHECK OUTSIDE KEY ANTENNA INPUT SIGNAL 1

1. Turn ignition switch OFF.
2. Check signal between BCM harness connector and ground using oscilloscope.

B2626 OUTSIDE ANTENNA

< DTC/CIRCUIT DIAGNOSIS >

(+)		(-)	Condition	Signal (Reference value)
BCM				
Connector	Terminal			
M80	114, 115	Ground	When Intelligent Key is in the antenna detection area. (The distance between Intelligent Key and antenna: 80 cm or less.)	<p>JMKIA5955GB</p>
			When the driver door request switch is operated with ignition switch OFF.	<p>JMKIA5954GB</p>

Is the inspection result normal?

YES >> Replace BCM. Refer to [BCS-79, "Removal and Installation"](#).

NO >> GO TO 2.

2.CHECK OUTSIDE KEY ANTENNA CIRCUIT

1. Disconnect BCM connector and outside key antenna (RH) connector.
2. Check continuity between BCM harness connector and outside key antenna (RH) harness connector.

BCM		Outside key antenna (RH)		Continuity
Connector	Terminal	Connector	Terminal	
M80	114	D116	1	Yes
	115		2	

3. Check continuity between BCM harness connector and ground.

BCM		Ground	Continuity
Connector	Terminal		
M80	114		Ground
	115		

Is the inspection result normal?

YES >> GO TO 3.

NO >> Repair or replace harness.

3.CHECK OUTSIDE KEY ANTENNA INPUT SIGNAL 2

1. Replace outside key antenna (RH). (New antenna or other antenna)
2. Connect BCM connector and outside key antenna (RH) connector.
3. Check signal between BCM harness connector and ground using oscilloscope.

B2626 OUTSIDE ANTENNA

< DTC/CIRCUIT DIAGNOSIS >

(+)		(-)	Condition		Signal (Reference value)
BCM					
Connector	Terminal				
M80	114, 115	Ground	When the driver door request switch is operated with ignition switch OFF.	When Intelligent Key is in the antenna detection area. (The distance between Intelligent Key and antenna: 80 cm or less.)	
				When Intelligent Key is not in the antenna detection area. (The distance between Intelligent Key and antenna: Approx. 2 m.)	

Is the inspection result normal?

- YES >> Replace outside key antenna (RH). Refer to [DLK-185, "OUTSIDE HANDLE : Removal and Installation"](#).
- NO >> Replace BCM. Refer to [BCS-79, "Removal and Installation"](#).

B2627 OUTSIDE ANTENNA

< DTC/CIRCUIT DIAGNOSIS >

B2627 OUTSIDE ANTENNA

DTC Description

INFOID:000000013037103

DTC DETECTION LOGIC

DTC No.	CONSULT screen terms (Trouble diagnosis content)	DTC Detection Condition	
		Diagnosis condition	When ignition switch is ON.
B2627	OUTSIDE ANTENNA	Signal (terminal)	BCM terminals 121,122
		Threshold	An excessive high or low voltage from outside key antenna LH is sent to BCM
		Diagnosis delay time	—

POSSIBLE CAUSE

- BCM
- Outside key antenna LH
- Harness or connector (Outside key antenna LH circuit is open or shorted.)

FAIL-SAFE

—

DTC CONFIRMATION PROCEDURE

1. PERFORM DTC CONFIRMATION PROCEDURE

Ⓜ CONSULT

1. Turn ignition switch ON.
2. Check "Self Diagnostic Result" mode of "BCM".

Is DTC detected?

- YES >> Refer to [DLK-93, "DTC Description"](#).
- NO-1 >> To check malfunction symptom before repair: Refer to [GI-43, "Intermittent Incident"](#).
- NO-2 >> Confirmation after repair: Inspection End.

Diagnosis Procedure

INFOID:000000013037104

DLK

Regarding Wiring Diagram information, refer to [DLK-39, "Wiring Diagram"](#).

1. CHECK OUTSIDE KEY ANTENNA INPUT SIGNAL 1

1. Turn ignition switch OFF.
2. Check signal between BCM harness connector and ground using oscilloscope.

B2627 OUTSIDE ANTENNA

< DTC/CIRCUIT DIAGNOSIS >

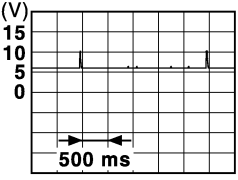
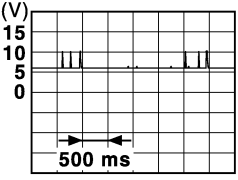
(+)		(-)	Condition	Signal (Reference value)
BCM				
Connector	Terminal			
M80	121, 122	Ground	When the driver door request switch is operated with ignition switch OFF.	<p>When Intelligent Key is in the antenna detection area. (The distance between Intelligent Key and antenna: 80 cm or less.)</p>  <p>JMKIA5955GB</p>
			When Intelligent Key is not in the antenna detection area. (The distance between Intelligent Key and antenna: Approx. 2 m.)	 <p>JMKIA5954GB</p>

Is the inspection result normal?

YES >> Replace BCM. Refer to [BCS-79, "Removal and Installation"](#).

NO >> GO TO 2.

2. CHECK OUTSIDE KEY ANTENNA CIRCUIT

1. Disconnect BCM connector and outside key antenna (LH) connector.
2. Check continuity between BCM harness connector and outside key antenna (LH) harness connector.

BCM		Outside key antenna (LH)		Continuity
Connector	Terminal	Connector	Terminal	
M80	122	D15	1	Yes
	121		2	

3. Check continuity between BCM harness connector and ground.

BCM		Ground	Continuity
Connector	Terminal		
M80	122		No
	121		

Is the inspection result normal?

YES >> GO TO 3.

NO >> Repair or replace harness.

3. CHECK OUTSIDE KEY ANTENNA INPUT SIGNAL 2

1. Replace outside key antenna (LH). (New antenna or other antenna)
2. Connect BCM connector and outside key antenna (LH) connector.
3. Check signal between BCM harness connector and ground using oscilloscope.

B2627 OUTSIDE ANTENNA

< DTC/CIRCUIT DIAGNOSIS >

(+)		(-)	Condition		Signal (Reference value)
BCM					
Connector	Terminal				
M80	122, 121	Ground	When the driver door request switch is operated with ignition switch OFF.	When Intelligent Key is in the antenna detection area. (The distance between Intelligent Key and antenna: 80 cm or less.)	
				When Intelligent Key is not in the antenna detection area. (The distance between Intelligent Key and antenna: Approx. 2 m.)	

Is the inspection result normal?

- YES >> Replace outside key antenna (LH). Refer to [DLK-185, "OUTSIDE HANDLE : Removal and Installation"](#).
- NO >> Replace BCM. Refer to [BCS-79, "Removal and Installation"](#).

A
B
C
D
E
F
G
H
I
J
L
M
N
O
P

DLK

DOOR SWITCH

< DTC/CIRCUIT DIAGNOSIS >

DOOR SWITCH

Component Function Check

INFOID:000000013037115

1. CHECK FUNCTION

CONSULT

1. Select "DOOR LOCK" of "BCM".
2. Select "DOOR SW-DR", "DOOR SW-AS", "DOOR SW-RL" or "DOOR SW-RR" in "Data Monitor" mode.
3. Check that the function operates normally according to the following conditions:

Monitor Item	Condition		Status
DOOR SW-DR	Front door LH	Open	On
		Closed	Off
DOOR SW-AS	Front door RH	Open	On
		Closed	Off
DOOR SW-RL	Rear door LH	Open	On
		Closed	Off
DOOR SW-RR	Rear door RH	Open	On
		Closed	Off

Is the inspection result normal?

- YES >> Door switch is OK.
 NO >> Refer to [DLK-96, "Diagnosis Procedure"](#).

Diagnosis Procedure

INFOID:000000013037116

Regarding Wiring Diagram information, refer to [DLK-39, "Wiring Diagram"](#).

1. CHECK DOOR SWITCH INPUT SIGNAL

1. Turn ignition switch OFF.
2. Disconnect malfunctioning door switch connector.
3. Check signal between malfunctioning door switch harness connector and ground using oscilloscope.

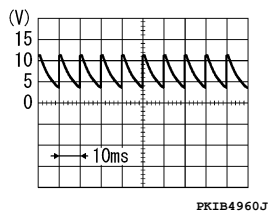
(+)		Terminal	(-)	Signal (Reference value)
Door switch				
Connector		3	Ground	
Front LH	B8			
Front RH	B108			
Rear LH	B18			
Rear RH	B116			

Is the inspection result normal?

- YES >> GO TO 3.
 NO >> GO TO 2.

2. CHECK DOOR SWITCH CIRCUIT

1. Disconnect BCM connector.
2. Check continuity between door switch harness connector and BCM harness connector.

DOOR SWITCH

< DTC/CIRCUIT DIAGNOSIS >

Door switch		BCM		Continuity
Connector	Terminal	Connector	Terminal	
Front LH	B8	3	M20	96
Front RH	B108			94
Rear LH	B18			82
Rear RH	B116			93

3. Check continuity between door switch harness connector and ground.

Door switch		Ground	Continuity
Connector	Terminal		
Front LH	B8	3	No
Front RH	B108		
Rear LH	B18		
Rear RH	B116		

Is the inspection result normal?

YES >> Replace BCM. Refer to [BCS-79, "Removal and Installation"](#).

NO >> Repair or replace harness.

3.CHECK DOOR SWITCH

Refer to [DLK-97, "Component Inspection"](#).

Is the inspection result normal?

YES >> GO TO 4.

NO >> Replace malfunctioning door switch. Refer to [DLK-183, "Removal and Installation"](#).

4.CHECK INTERMITTENT INCIDENT

Refer to [GI-43, "Intermittent Incident"](#).

>> Inspection End.

Component Inspection

INFOID:000000013037117

DLK

1.CHECK DOOR SWITCH

1. Turn ignition switch OFF.
2. Disconnect malfunctioning door switch connector.
3. Check continuity between door switch terminals.

Door switch		Condition		Continuity
Terminal				
3	Ground contact is part of the switch.	Door switch	Pressed	No
			Released	Yes

Is the inspection result normal?

YES >> Inspection End.

NO >> Replace malfunctioning door switch. Refer to [DLK-183, "Removal and Installation"](#).

DOOR LOCK AND UNLOCK SWITCH

< DTC/CIRCUIT DIAGNOSIS >

DOOR LOCK AND UNLOCK SWITCH DRIVER SIDE

DRIVER SIDE : Component Function Check

INFOID:0000000013037123

1.CHECK FUNCTION

CONSULT

1. Select "DOOR LOCK" of "BCM".
2. Select "CDL LOCK SW" or "CDL UNLOCK SW" in "Data Monitor" mode.
3. Check that the function operates normally according to the following conditions:

Monitor Item	Condition	Status
CDL LOCK SW	Lock	ON
	Unlock	OFF
CDL UNLOCK SW	Lock	OFF
	Unlock	ON

Is the inspection result normal?

YES >> Door lock and unlock switch is OK.

NO >> Refer to [DLK-98, "DRIVER SIDE : Diagnosis Procedure"](#).

DRIVER SIDE : Diagnosis Procedure

INFOID:0000000013037124

1.CHECK POWER WINDOW SWITCH

1. Turn ignition switch ON.
2. Check power window operation.

Does power window operate?

YES >> Replace power window main switch. Refer to [PWC-77, "Removal and Installation"](#).

NO >> Refer to [PWC-36, "POWER WINDOW MAIN SWITCH : Diagnosis Procedure"](#).

PASSENGER SIDE

PASSENGER SIDE : Component Function Check

INFOID:0000000013037125

1.CHECK FUNCTION

CONSULT

1. Select "DOOR LOCK" of "BCM".
2. Select "CDL LOCK SW" or "CDL UNLOCK SW" in "Data Monitor" mode.
3. Check that the function operates normally according to the following conditions:

Monitor Item	Condition	Status
CDL LOCK SW	Lock	ON
	Unlock	OFF
CDL UNLOCK SW	Lock	OFF
	Unlock	ON

Is the inspection result normal?

YES >> Door lock and unlock switch is OK.

NO >> Refer to [DLK-98, "PASSENGER SIDE : Diagnosis Procedure"](#).

PASSENGER SIDE : Diagnosis Procedure

INFOID:0000000013037126

1.CHECK POWER WINDOW SWITCH

1. Turn ignition switch ON.
2. Check power window operation.

Does power window operate?

DOOR LOCK AND UNLOCK SWITCH

< DTC/CIRCUIT DIAGNOSIS >

-
- YES >> Replace front power window switch (passenger side). Refer to [PWC-79. "Removal and Installation"](#).
- NO >> Refer to [PWC-38. "FRONT POWER WINDOW SWITCH \(PASSENGER SIDE\) : Diagnosis Procedure"](#).

A

B

C

D

E

F

G

H

I

J

DLK

L

M

N

O

P

DOOR LOCK ACTUATOR

< DTC/CIRCUIT DIAGNOSIS >

DOOR LOCK ACTUATOR DRIVER SIDE

DRIVER SIDE : Component Function Check

INFOID:000000013037127

1. CHECK FUNCTION

CONSULT

1. Select "DOOR LOCK" of "BCM".
2. Select "DOOR LOCK" in "Active Test" mode.
3. Touch "ALL LOCK" or "ALL UNLK" to check that it works normally.

Is the inspection result normal?

YES >> Door lock actuator is OK.

NO >> Refer to [DLK-100, "DRIVER SIDE : Diagnosis Procedure"](#).

DRIVER SIDE : Diagnosis Procedure

INFOID:000000013037128

Regarding Wiring Diagram information, refer to [DLK-56, "Wiring Diagram"](#).

1. CHECK DOOR LOCK ACTUATOR INPUT SIGNAL

1. Turn ignition switch OFF.
2. Disconnect front door lock assembly LH connector.
3. Check voltage between front door lock assembly LH harness connector and ground.

(+)		(-)	Condition	Voltage (Approx.)
Front door lock assembly LH Connector	Terminal			
D14	1	Ground	Door lock and unlock switch	Battery voltage
	2		Lock Unlock	

Is the inspection result normal?

YES >> Replace front door lock assembly LH. Refer to [DLK-167, "DOOR LOCK : Removal and Installation"](#).

NO >> GO TO 2.

2. CHECK DOOR LOCK ACTUATOR CIRCUIT

1. Disconnect BCM and all door lock actuators.
2. Check continuity between BCM harness connector and front door lock assembly LH harness connector.

BCM		Front door lock assembly LH		Continuity
Connector	Terminal	Connector	Terminal	
M81	135	D14	1	Yes
	137		2	

3. Check continuity between BCM harness connector and ground.

BCM		Ground	Continuity
Connector	Terminal		
M81	135		No
	137		

Is the inspection result normal?

YES >> GO TO 3.

NO >> Repair or replace harness.

DOOR LOCK ACTUATOR

< DTC/CIRCUIT DIAGNOSIS >

3.CHECK BCM OUTPUT SIGNAL

1. Connect BCM connector.
2. Check voltage between BCM harness connector and ground.

(+)		(-)	Condition	Voltage (Approx.)
BCM				
Connector	Terminal			
M81	135	Ground	Door lock and unlock switch	Lock
	137			Unlock
				Battery voltage

Is the inspection result normal?

- YES >> Check for internal short of each door lock actuator.
 NO >> Replace BCM. Refer to [BCS-79, "Removal and Installation"](#).

PASSENGER SIDE

PASSENGER SIDE : Component Function Check

INFOID:000000013037129

1.CHECK FUNCTION

CONSULT

1. Select "DOOR LOCK" of "BCM".
2. Select "DOOR LOCK" in "Active Test" mode.
3. Touch "ALL LOCK" or "ALL UNLK" to check that it works normally.

Is the inspection result normal?

- YES >> Door lock actuator is OK.
 NO >> Refer to [DLK-101, "PASSENGER SIDE : Diagnosis Procedure"](#).

PASSENGER SIDE : Diagnosis Procedure

INFOID:000000013037130

Regarding Wiring Diagram information, refer to [DLK-56, "Wiring Diagram"](#).

1.CHECK DOOR LOCK ACTUATOR INPUT SIGNAL

1. Turn ignition switch OFF.
2. Disconnect front door lock actuator RH connector.
3. Check voltage between front door lock actuator RH harness connector and ground.

(+)		(-)	Condition	Voltage (Approx.)
Front door lock actuator RH				
Connector	Terminal			
D114	1	Ground	Door lock and unlock switch	Unlock
	2			Lock
				Battery voltage

Is the inspection result normal?

- YES >> Replace front door lock actuator RH. Refer to [DLK-167, "DOOR LOCK : Removal and Installation"](#).
 NO >> GO TO 2.

2.CHECK DOOR LOCK ACTUATOR CIRCUIT

1. Disconnect BCM and all door lock actuators.
2. Check continuity between BCM harness connector and front door lock actuator RH harness connector.

A
B
C
D
E
F
G
H
I
J
L
M
N
O
P

DLK

DOOR LOCK ACTUATOR

< DTC/CIRCUIT DIAGNOSIS >

BCM		Front door lock actuator RH		Continuity
Connector	Terminal	Connector	Terminal	
M81	130	D114	1	Yes
	132		2	

3. Check continuity between BCM harness connector and ground.

BCM		Ground	Continuity
Connector	Terminal		
M81	130		No
	132		

Is the inspection result normal?

YES >> GO TO 3.

NO >> Repair or replace harness.

3.CHECK BCM OUTPUT SIGNAL

1. Connect BCM connector.
2. Check voltage between BCM harness connector and ground.

(+)		(-)	Condition	Voltage (Approx.)
BCM				
Connector	Terminal	Ground	Door lock and unlock switch	Battery voltage
M81	130			
	132	Lock		

Is the inspection result normal?

YES >> Check for internal short of each door lock actuator.

NO >> Replace BCM. Refer to [BCS-79, "Removal and Installation"](#).

REAR LH

REAR LH : Component Function Check

INFOID:000000013037131

1.CHECK FUNCTION

CONSULT

1. Select "DOOR LOCK" of "BCM".
2. Select "DOOR LOCK" in "Active Test" mode.
3. Touch "ALL LOCK" or "ALL UNLK" to check that it works normally.

Is the inspection result normal?

YES >> Door lock actuator is OK.

NO >> Refer to [DLK-102, "REAR LH : Diagnosis Procedure"](#).

REAR LH : Diagnosis Procedure

INFOID:000000013037132

Regarding Wiring Diagram information, refer to [DLK-56, "Wiring Diagram"](#).

1.CHECK DOOR LOCK ACTUATOR INPUT SIGNAL

1. Turn ignition switch OFF.
2. Disconnect rear door lock actuator LH connector.
3. Check voltage between rear door lock actuator LH harness connector and ground.

DOOR LOCK ACTUATOR

< DTC/CIRCUIT DIAGNOSIS >

(+)		(-)	Condition	Voltage (Approx.)
Rear door lock actuator LH				
Connector	Terminal			
D205	1	Ground	Door lock and unlock switch	Lock
	2			Unlock
Battery voltage				

Is the inspection result normal?

YES >> Replace rear door lock actuator LH. Refer to [DLK-172, "DOOR LOCK : Removal and Installation"](#).

NO >> GO TO 2.

2. CHECK DOOR LOCK ACTUATOR CIRCUIT

1. Disconnect BCM and all door lock actuators.
2. Check continuity between BCM harness connector and rear door lock actuator LH harness connector.

BCM		Rear door lock actuator LH		Continuity
Connector	Terminal	Connector	Terminal	
M81	133	D205	2	Yes
	132		1	

3. Check continuity between BCM harness connector and ground.

BCM		Ground	Continuity
Connector	Terminal		
M81	133		No
	132		

Is the inspection result normal?

YES >> GO TO 3.

NO >> Repair or replace harness.

3. CHECK BCM OUTPUT SIGNAL

1. Connect BCM connector.
2. Check voltage between BCM harness connector and ground.

(+)		(-)	Condition	Voltage (Approx.)
BCM				
Connector	Terminal			
M81	133	Ground	Door lock and unlock switch	Unlock
	132			Lock
Battery voltage				

Is the inspection result normal?

YES >> Check for internal short of each door lock actuator.

NO >> Replace BCM. Refer to [BCS-79, "Removal and Installation"](#).

REAR RH

REAR RH : Component Function Check

INFOID:0000000013037133

1. CHECK FUNCTION

CONSULT

1. Select "DOOR LOCK" of "BCM".
2. Select "DOOR LOCK" in "Active Test" mode.
3. Touch "ALL LOCK" or "ALL UNLK" to check that it works normally.

Is the inspection result normal?

YES >> Door lock actuator is OK.

NO >> Refer to [DLK-104, "REAR RH : Diagnosis Procedure"](#).

DOOR LOCK ACTUATOR

< DTC/CIRCUIT DIAGNOSIS >

REAR RH : Diagnosis Procedure

INFOID:000000013037134

Regarding Wiring Diagram information, refer to [DLK-56. "Wiring Diagram"](#).

1. CHECK DOOR LOCK ACTUATOR INPUT SIGNAL

1. Turn ignition switch OFF.
2. Disconnect rear door lock actuator RH connector.
3. Check voltage between rear door lock actuator RH harness connector and ground.

(+)		(-)	Condition	Voltage (Approx.)
Connector	Terminal			
D305	1	Ground	Door lock and unlock switch	Unlock
	2			Lock
Battery voltage				

Is the inspection result normal?

- YES >> Replace rear door lock actuator RH. Refer to [DLK-172. "DOOR LOCK : Removal and Installation"](#).
 NO >> GO TO 2.

2. CHECK DOOR LOCK ACTUATOR CIRCUIT

1. Disconnect BCM and all door lock actuators.
2. Check continuity between BCM harness connector and rear door lock actuator RH harness connector.

BCM		Rear door lock actuator RH		Continuity
Connector	Terminal	Connector	Terminal	
M81	133	D305	1	Yes
	132		2	

3. Check continuity between BCM harness connector and ground.

BCM		Ground	Continuity
Connector	Terminal		
M81	133		No
	132		

Is the inspection result normal?

- YES >> GO TO 3.
 NO >> Repair or replace harness.

3. CHECK BCM OUTPUT SIGNAL

1. Connect BCM connector.
2. Check voltage between BCM harness connector and ground.

(+)		(-)	Condition	Voltage (Approx.)
Connector	Terminal			
M81	133	Ground	Door lock and unlock switch	Unlock
	132			Lock
Battery voltage				

Is the inspection result normal?

- YES >> Check for internal short of each door lock actuator.
 NO >> Replace BCM. Refer to [BCS-79. "Removal and Installation"](#).

UNLOCK SENSOR

< DTC/CIRCUIT DIAGNOSIS >

UNLOCK SENSOR

Component Function Check

INFOID:000000013037135

1.CHECK FUNCTION

CONSULT

1. Select "INTELLIGENT KEY" of "BCM".
2. Select "UNLK SEN-DR" in "Data Monitor" mode.
3. Check that the function operates normally according to the following conditions:

Monitor Item	Condition		Status
UNLK SEN -DR	Driver side door	Lock	OFF
		Unlock	ON

Is the inspection result normal?

- YES >> Unlock sensor is OK.
 NO >> Refer to [DLK-105, "Diagnosis Procedure"](#).

Diagnosis Procedure

INFOID:000000013037136

Regarding Wiring Diagram information, refer to [DLK-56, "Wiring Diagram"](#).

1.CHECK UNLOCK SENSOR INPUT SIGNAL

1. Turn ignition switch OFF.
2. Disconnect front door lock assembly LH connector.
3. Check signal between front door lock assembly LH harness connector and ground with oscilloscope.

(+)		(-)	Signal (Reference value)
Front door lock assembly LH			
Connector	Terminal		
D14	3	Ground	

Is the inspection result normal?

- YES >> GO TO 3.
 NO >> GO TO 2.

2.CHECK UNLOCK SENSOR CIRCUIT

1. Disconnect BCM connector.
2. Check continuity between BCM harness connector and front door lock assembly LH harness connector.

BCM		Front door lock assembly LH		Continuity
Connector	Terminal	Connector	Terminal	
M18	30	D14	3	Yes

3. Check continuity between BCM harness connector and ground.

A
B
C
D
E
F
G
H
I
J
L
M
N
O
P

DLK

UNLOCK SENSOR

< DTC/CIRCUIT DIAGNOSIS >

BCM		Ground	Continuity
Connector	Terminal		
M18	30		No

Is the inspection result normal?

YES >> Replace BCM. Refer to [BCS-79, "Removal and Installation"](#).

NO >> Repair or replace harness.

3.CHECK UNLOCK SENSOR GROUND CIRCUIT

Check continuity between front door lock assembly LH harness connector and ground.

Front door lock assembly LH		Ground	Continuity
Connector	Terminal		
D14	4		Yes

Is the inspection result normal?

YES >> GO TO 4.

NO >> Repair or replace harness.

4.CHECK UNLOCK SENSOR

Refer to [DLK-106, "Component Inspection"](#).

Is the inspection result normal?

YES >> GO TO 5.

NO >> Replace front door lock assembly LH. Refer to [DLK-167, "DOOR LOCK : Removal and Installation"](#).

5.CHECK INTERMITTENT INCIDENT

Refer to [GI-43, "Intermittent Incident"](#).

>> Inspection End.

Component Inspection

INFOID:000000013037137

1.CHECK UNLOCK SENSOR

1. Turn ignition switch OFF.
2. Disconnect front door lock assembly LH connector.
3. Check continuity between front door lock assembly LH terminals.

Front door lock assembly LH		Condition	Continuity	
Terminal				
3	4	Driver side door	Unlock	Yes
			Lock	No

Is the inspection result normal?

YES >> Inspection End.

NO >> Replace front door lock assembly LH. Refer to [DLK-167, "DOOR LOCK : Removal and Installation"](#).

DOOR KEY CYLINDER SWITCH

< DTC/CIRCUIT DIAGNOSIS >

DOOR KEY CYLINDER SWITCH

Component Function Check

INFOID:000000013037138

1. CHECK FUNCTION

CONSULT

1. Select "DOOR LOCK" of "BCM".
2. Select "KEY CYL LK-SW" or "KEY CYL UN-SW" in "Data Monitor" mode.
3. Check that the function operates normally according to the following conditions:

Monitor Item	Condition	Status
KEY CYL LK-SW	Lock	ON
	Neutral / Unlock	OFF
KEY CYL UN-SW	Unlock	ON
	Neutral / Lock	OFF

Is the inspection result normal?

- YES >> Door key cylinder switch is OK.
NO >> Refer to [DLK-107. "Diagnosis Procedure"](#).

Diagnosis Procedure

INFOID:000000013037139

Regarding Wiring Diagram information, refer to [DLK-56. "Wiring Diagram"](#).

1. CHECK DOOR KEY CYLINDER SWITCH INPUT SIGNAL

1. Turn ignition switch OFF.
2. Disconnect front door lock assembly LH connector.
3. Check voltage between front door lock assembly LH harness connector and ground.

(+)		(-)	Voltage (Approx.)
Connector	Terminal		
D14	5	Ground	5 V
	6		

Is the inspection result normal?

- YES >> GO TO 3.
NO >> GO TO 2.

2. CHECK DOOR KEY CYLINDER SWITCH SIGNAL CIRCUIT

1. Disconnect main power window and door lock/unlock switch connector.
2. Check continuity between main power window and door lock/unlock switch harness connector and front door lock assembly LH harness connector.

Main power window and door lock/unlock switch		Front door lock assembly LH		Continuity
Connector	Terminal	Connector	Terminal	
D7	3	D14	6	Yes
	15		5	

3. Check continuity between power window main switch harness connector and ground.

A
B
C
D
E
F
G
H
I
J
L
M
N
O
P

DLK

DOOR KEY CYLINDER SWITCH

< DTC/CIRCUIT DIAGNOSIS >

Main power window and door lock/unlock switch		Ground	Continuity
Connector	Terminal		
D7	3		
	15		

Is the inspection result normal?

YES >> Replace main power window and door lock/unlock switch. Refer to [PWC-77, "Removal and Installation"](#).

NO >> Repair or replace harness.

3. CHECK DOOR KEY CYLINDER SWITCH GROUND CIRCUIT

Check continuity between front door lock assembly LH harness connector and ground.

Front door lock assembly LH		Ground	Continuity
Connector	Terminal		
D14	4		

Is the inspection result normal?

YES >> GO TO 4.

NO >> Repair or replace harness.

4. CHECK DOOR KEY CYLINDER SWITCH

Refer to [DLK-108, "Component Inspection"](#).

Is the inspection result normal?

YES >> GO TO 5.

NO >> Replace front door lock assembly LH. Refer to [DLK-167, "DOOR LOCK : Removal and Installation"](#).

5. CHECK INTERMITTENT INCIDENT

Refer to [GI-43, "Intermittent Incident"](#).

>> Inspection End.

Component Inspection

INFOID:000000013037140

1. CHECK DOOR KEY CYLINDER SWITCH

1. Turn ignition switch OFF.
2. Disconnect front door lock assembly LH connector.
3. Check continuity between front door lock assembly LH terminals.

Front door lock assembly LH		Condition	Continuity
Terminal			
5	4		Driver side door key cylinder
		Neutral / Lock	
6		Lock	
		Neutral / Unlock	

Is the inspection result normal?

YES >> Inspection End.

NO >> Replace front door lock assembly LH. Refer to [DLK-167, "DOOR LOCK : Removal and Installation"](#).

REMOTE KEYLESS ENTRY RECEIVER

< DTC/CIRCUIT DIAGNOSIS >

REMOTE KEYLESS ENTRY RECEIVER

Component Function Check

INFOID:000000013037141

1.CHECK FUNCTION

CONSULT

1. Select "INTELLIGENT KEY" of "BCM".
2. Select "RKE OPE COUN1" in "DATA MONITOR" mode.
3. Check that the function operates normally according to the following conditions:

Monitor Item	Condition
RKE OPE COUN1	Checks whether value changes when operating Intelligent Key.

Is the inspection result normal?

- YES >> Remote keyless entry receiver is OK.
 NO >> Refer to [DLK-109, "Diagnosis Procedure"](#).

Diagnosis Procedure

INFOID:000000013037142

Regarding Wiring Diagram information, refer to [DLK-39, "Wiring Diagram"](#).

1.CHECK REMOTE KEYLESS ENTRY RECEIVER OUTPUT SIGNAL

1. Turn ignition switch OFF.
2. Check signal between BCM harness connector and ground using oscilloscope.

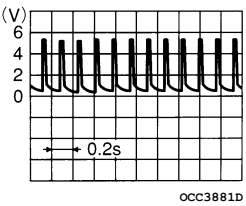
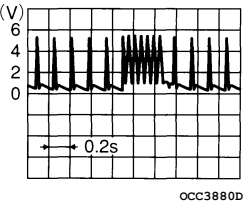
(+)		(-)	Condition	Signal (Reference value)
BCM				
Connector	Terminal			
M80	119	Ground	Standby state	
			Press the Intelligent Key lock or unlock button.	

Is the inspection result normal?

- YES >> Replace BCM. Refer to [BCS-79, "Removal and Installation"](#).
 NO >> GO TO 2.

2.CHECK REMOTE KEYLESS ENTRY RECEIVER CIRCUIT 1

1. Disconnect BCM and remote keyless entry receiver connectors.
2. Check continuity between BCM harness connector and remote keyless entry receiver harness connector.

A
B
C
D
E
F
G
H
I
J
L
M
N
O
P

DLK

REMOTE KEYLESS ENTRY RECEIVER

< DTC/CIRCUIT DIAGNOSIS >

BCM		Remote keyless entry receiver		Continuity
Connector	Terminal	Connector	Terminal	
M80	119	M86	2	Yes

3. Check continuity between BCM harness connector and ground.

(+)		(-)	Continuity
BCM			
Connector	Terminal		
M80	119	Ground	No

Is the inspection result normal?

YES >> GO TO 3.

NO >> Repair or replace harness.

3.CHECK REMOTE KEYLESS ENTRY RECEIVER POWER SUPPLY

Check voltage between remote keyless entry receiver harness connector and ground.

(+)		(-)	Voltage (Approx.)
Remote keyless entry receiver			
Connector	Terminal		
M86	1	Ground	Battery voltage

Is the inspection result normal?

YES >> GO TO 4.

NO-1 >> Check 5A fuse No. 9 [located in fuse block J/B].

NO-2 >> Repair or replace harness between remote keyless entry receiver and 5A fuse No. 9.

4.CHECK REMOTE KEYLESS ENTRY RECEIVER GROUND CIRCUIT

Check continuity between remote keyless entry receiver harness connector and ground.

Remote keyless entry receiver		Ground	Continuity
Connector	Terminal		
M86	3		Yes

Is the inspection result normal?

YES >> Replace remote keyless entry receiver. Refer to [DLK-188. "Removal and Installation"](#).

NO >> Repair or replace harness.

DOOR REQUEST SWITCH

< DTC/CIRCUIT DIAGNOSIS >

DOOR REQUEST SWITCH

Component Function Check

INFOID:000000013037143

1.CHECK FUNCTION

CONSULT

1. Select "INTELLIGENT KEY" of "BCM".
2. Select "REQ SW-DR" or "REQ SW-AS" in "Data Monitor" mode.
3. Check that the function operates normally according to the following conditions:

Monitor Item	Condition	Status	
REQ SW -DR	LH door request switch	Pressed	ON
		Released	OFF
REQ SW -AS	RH door request switch	Pressed	ON
		Released	OFF

Is the inspection result normal?

- YES >> Front door request switch is OK.
NO >> Refer to [DLK-111, "Diagnosis Procedure"](#).

Diagnosis Procedure

INFOID:000000013037144

Regarding Wiring Diagram information, refer to [DLK-39, "Wiring Diagram"](#).

1.CHECK DOOR REQUEST SWITCH INPUT SIGNAL

1. Turn ignition switch OFF.
2. Disconnect malfunctioning front door request switch connector.
3. Check voltage between malfunctioning front door request switch harness connector and ground.

(+)		Terminal	(-)	Voltage (Approx.)
Front door request switch				
Connector	Terminal	3	Ground	Battery voltage
LH	D15			
RH	D116			

Is the inspection result normal?

- YES >> GO TO 3.
NO >> GO TO 2.

2.CHECK DOOR REQUEST SWITCH CIRCUIT

1. Disconnect BCM connector.
2. Check continuity between malfunctioning front door request switch harness connector and BCM harness connector.

Front door request switch		BCM		Continuity
Connector	Terminal	Connector	Terminal	
LH	D15	M19	71	Yes
RH	D116		72	

3. Check continuity between malfunctioning front door request switch harness connector and ground.

DOOR REQUEST SWITCH

< DTC/CIRCUIT DIAGNOSIS >

Front door request switch		Terminal	Ground	Continuity
Connector				Continuity
LH	D15	3		No
RH	D116			

Is the inspection result normal?

YES >> Replace BCM. Refer to [BCS-79. "Removal and Installation"](#).

NO >> Repair or replace harness.

3.CHECK DOOR REQUEST SWITCH GROUND CIRCUIT

Check continuity between malfunctioning front door request switch harness connector and ground.

Front door request switch		Terminal	Ground	Continuity
Connector				Continuity
LH	D15	4		Yes
RH	D116			

Is the inspection result normal?

YES >> GO TO 4.

NO >> Repair or replace harness.

4.CHECK DOOR REQUEST SWITCH

Refer to [DLK-112. "Component Inspection"](#).

Is the inspection result normal?

YES >> GO TO 5.

NO >> Replace malfunctioning front outside handle assembly. Refer to [DLK-169. "OUTSIDE HANDLE : Removal and Installation"](#).

5.CHECK INTERMITTENT INCIDENT

Refer to [GI-43. "Intermittent Incident"](#).

>> Inspection End.

Component Inspection

INFOID:000000013037145

1.CHECK DOOR REQUEST SWITCH

1. Turn ignition switch OFF.
2. Disconnect malfunctioning front door request switch connector.
3. Check continuity between malfunctioning front door request switch terminals.

Front door request switch		Condition	Continuity	
Terminal				Continuity
3	4	Door request switch	Pressed	Yes
			Released	No

Is the inspection result normal?

YES >> Inspection End.

NO >> Replace malfunctioning front door request switch. Refer to [DLK-186. "DRIVER SIDE : Removal and Installation"](#) or [DLK-186. "PASSENGER SIDE : Removal and Installation"](#).

INTELLIGENT KEY WARNING BUZZER

< DTC/CIRCUIT DIAGNOSIS >

INTELLIGENT KEY WARNING BUZZER

Component Function Check

INFOID:000000013037152

1.CHECK FUNCTION

CONSULT

1. Select "INTELLIGENT KEY" of "BCM".
2. Select "OUTSIDE BUZZER" in "Active Test" mode.
3. Touch "On" or "Off" to check that it works normally.

Is the inspection result normal?

- YES >> Intelligent Key warning buzzer is OK.
NO >> Refer to [DLK-113. "Diagnosis Procedure"](#).

Diagnosis Procedure

INFOID:000000013037153

Regarding Wiring Diagram information, refer to [DLK-39. "Wiring Diagram"](#).

1.CHECK INTELLIGENT KEY WARNING BUZZER CIRCUIT

1. Disconnect BCM connector.
2. Check continuity between BCM harness connector and Intelligent Key warning buzzer harness connector.

BCM		Intelligent Key warning buzzer		Continuity
Connector	Terminal	Connector	Terminal	
M19	64	E1	3	Yes

3. Check continuity between BCM harness connector and ground.

BCM		Ground	Continuity
Connector	Terminal		
M19	64		No

Is the inspection result normal?

- YES >> GO TO 2.
NO >> Repair or replace harness.

2.CHECK INTELLIGENT KEY WARNING BUZZER

Refer to [DLK-113. "Component Inspection"](#).

Is the inspection result normal?

- YES >> Replace BCM. Refer to [BCS-79. "Removal and Installation"](#).
NO >> Replace Intelligent Key warning buzzer. Refer to [DLK-187. "Removal and Installation"](#).

Component Inspection

INFOID:000000013037154

1.CHECK INTELLIGENT KEY WARNING BUZZER

1. Turn ignition switch OFF.
2. Disconnect Intelligent Key warning buzzer connector.
3. Connect battery power supply directly to Intelligent Key warning buzzer terminals and check the operation.

Intelligent Key warning buzzer		Operation
Terminal		
(+)	(-)	Buzzer sounds
1	3	

Is the inspection result normal?

A
B
C
D
E
F
G
H
I
J
L
M
N
O
P

DLK

INTELLIGENT KEY WARNING BUZZER

< DTC/CIRCUIT DIAGNOSIS >

YES >> Inspection End.

NO >> Replace Intelligent Key warning buzzer. Refer to [DLK-187, "Removal and Installation"](#).

INTELLIGENT KEY

< DTC/CIRCUIT DIAGNOSIS >

INTELLIGENT KEY

Component Function Check

INFOID:000000013037155

NOTE:

The Signal Tech II Tool [- (J-50190)] can be used to perform the following functions: Refer to the Signal Tech II User Guide for additional information.

- Check Intelligent Key relative signal strength.
- Confirm vehicle Intelligent Key antenna signal strength.

1. CHECK FUNCTION

CONSULT

1. Select "INTELLIGENT KEY" of "BCM".
2. Select "RKE OPE COUN1" in "Data Monitor" mode.
3. Check that the function operates normally according to the following conditions:

Monitor Item	Condition
RKE OPE COUN1	Check that the numerical value is changing while operating the Intelligent Key.

Is the inspection result normal?

- YES >> Intelligent Key is OK.
NO >> Refer to [DLK-115, "Diagnosis Procedure"](#).

Diagnosis Procedure

INFOID:000000013037156

NOTE:

The Signal Tech II Tool [- (J-50190)] can be used to perform the following functions. Refer to the Signal Tech II User Guide for additional information.

- Check Intelligent Key relative signal strength.
- Confirm vehicle Intelligent Key antenna signal strength.

1. CHECK INTELLIGENT KEY BATTERY

Check by connecting a resistance (approximately 300Ω) so that the current value becomes about 10 mA. Refer to [DLK-189, "Removal and Installation"](#).

Standard : Approx. 2.5 - 3.0V

Is the measurement value within the standard?

- YES >> Replace Intelligent Key.
NO >> Replace Intelligent Key battery.

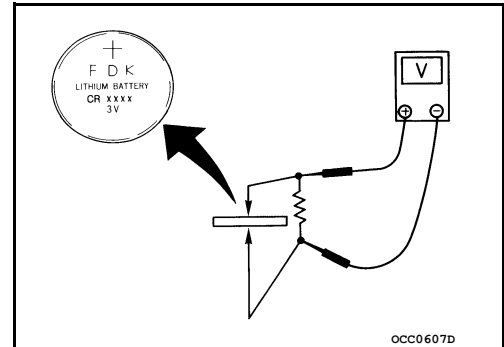

METER BUZZER CIRCUIT

< DTC/CIRCUIT DIAGNOSIS >

METER BUZZER CIRCUIT

Description

INFOID:000000013037157

- The buzzer for the warning chime system is installed in the combination meter.
- The combination meter sounds the buzzer based on the signals transmitted from various units.

Component Function Check

INFOID:000000013037158

1. CHECK OPERATION OF METER BUZZER

Ⓢ CONSULT

1. Select "BUZZER" of "BCM".
2. Perform "LIGHT WARN ALM" or "SEAT BELT WARN TEST" of "Active Test" mode.

Does meter buzzer activate?

- YES >> Inspection End.
NO >> Refer to [DLK-116, "Diagnosis Procedure"](#).

Diagnosis Procedure

INFOID:000000013037159

1. CHECK COMBINATION METER INPUT SIGNAL

Ⓢ CONSULT

Select the "Data Monitor" mode of the "METER/M&A" and check the "BUZZER" monitor value.

BUZZER

Under the condition of buzzer input : On
Except above : Off

Is the inspection result normal?

- YES >> Replace combination meter. Refer to [MWI-108, "Removal and Installation"](#).
NO >> Replace BCM. Refer to [BCS-79, "Removal and Installation"](#).

KEY WARNING LAMP

< DTC/CIRCUIT DIAGNOSIS >

KEY WARNING LAMP

Component Function Check

INFOID:000000013037160

1.CHECK FUNCTION

CONSULT

1. Select "INTELLIGENT KEY" of "BCM".
2. Select "INDICATOR" in "Active Test" mode.
3. Touch "KEY IND" or "KEY ON" to check that it works normally.

Is the inspection result normal?

YES >> Key warning lamp is OK.

NO >> Refer to [DLK-117. "Diagnosis Procedure"](#).

Diagnosis Procedure

INFOID:000000013037161

1.CHECK KEY WARNING LAMP

Refer to [MWI-27. "CONSULT Function \(METER/M&A\)"](#).

Is the inspection result normal?

YES >> GO TO 2.

NO >> Repair or replace the malfunctioning parts.

2.CHECK INTERMITTENT INCIDENT

Refer to [GI-43. "Intermittent Incident"](#).

>> Inspection End.

A
B
C
D
E
F
G
H
I
J
L
M
N
O
P

DLK

HAZARD FUNCTION

< DTC/CIRCUIT DIAGNOSIS >

HAZARD FUNCTION

Component Function Check

INFOID:000000013037162

1.CHECK FUNCTION

④ CONSULT

1. Select "INTELLIGENT KEY" of "BCM".
2. Select "FLASHER" in "Active Test" mode.
3. Touch "LH" or "RH" to check that it works normally.

Is the inspection result normal?

- YES >> Hazard warning lamp circuit is OK.
NO >> Refer to [DLK-118, "Diagnosis Procedure"](#).

Diagnosis Procedure

INFOID:000000013037163

1.CHECK HAZARD SWITCH CIRCUIT

Refer to [DLK-118, "Component Function Check"](#).

Is the inspection result normal?

- YES >> GO TO 2.
NO >> Repair or replace the malfunctioning parts.

2.CHECK INTERMITTENT INCIDENT

Refer to [GI-43, "Intermittent Incident"](#).

>> Inspection End.

HOOD SWITCH

< DTC/CIRCUIT DIAGNOSIS >

HOOD SWITCH

Component Function Check

INFOID:000000013037187

1.CHECK FUNCTION

CONSULT

1. Select "HOOD SW" in "Data Monitor" mode of "IPDM E/R".
2. Check "HOOD SW" indication under the following conditions:

Monitor Item	Condition		Indication
HOOD SW	Hood	Open	ON
		Close	OFF

Is the indication normal?

YES >> Hood switch is OK.

NO >> Go to [DLK-119, "Diagnosis Procedure"](#).

Diagnosis Procedure

INFOID:000000013037188

Regarding Wiring Diagram information, refer to [DLK-39, "Wiring Diagram"](#).

1.CHECK HOOD SWITCH SIGNAL CIRCUITS

1. Turn ignition switch OFF.
2. Disconnect hood switch connector.
3. Check voltage between hood switch harness connector and ground.

(+)		(-)	Voltage (V) (Approx.)
Hood switch			
Connector	Terminal	Ground	Battery voltage
E94	3		
	2		

Is the inspection result normal?

YES >> GO TO 3.

NO >> GO TO 2.

2.CHECK HOOD SWITCH SIGNAL CIRCUITS

1. Disconnect IPDM E/R connector.
2. Check continuity between IPDM E/R harness connector and hood switch harness connector.

IPDM E/R		Hood switch		Continuity
Connector	Terminal	Connector	Terminal	
E130	71	E94	3	Yes
E122	46		2	

3. Check continuity between IPDM E/R harness connector and ground.

IPDM E/R		Ground	Continuity
Connector	Terminal		
E130	71	Ground	No
E122	46		

Is the inspection result normal?

YES >> Replace IPDM E/R. Refer to [PCS-43, "Removal and Installation of IPDM E/R"](#).

HOOD SWITCH

< DTC/CIRCUIT DIAGNOSIS >

NO >> Repair or replace harness.

3.CHECK HOOD SWITCH GROUND CIRCUIT

Check continuity between hood switch harness connector and ground.

Hood switch		Ground	Continuity
Connector	Terminal		
E94	1		Yes

Is the inspection result normal?

YES >> GO TO 4.

NO >> Repair or replace harness.

4.CHECK HOOD SWITCH

Refer to [DLK-120, "Component Inspection"](#).

Is the inspection result normal?

YES >> GO TO 5.

NO >> Replace hood switch. Refer to [DLK-165, "HOOD LOCK : Removal and Installation"](#).

5.CHECK INTERMITTENT INCIDENT

Refer to [GI-43, "Intermittent Incident"](#).

>> Inspection End.

Component Inspection

INFOID:000000013037189

1.CHECK HOOD SWITCH

1. Turn ignition switch OFF.
2. Disconnect hood switch connector.
3. Check continuity between hood switch terminals.

Hood switch		Condition	Continuity
Terminal			
3	1	Press	Yes
		Release	No
2		Press	No
		Release	Yes

Is the inspection result normal?

YES >> Inspection End.

NO >> Replace hood switch. Refer to [DLK-165, "HOOD LOCK : Removal and Installation"](#).

INTEGRATED HOMELINK TRANSMITTER

< DTC/CIRCUIT DIAGNOSIS >

INTEGRATED HOMELINK TRANSMITTER

Component Function Check

INFOID:000000013037190

1.CHECK FUNCTION

Check that system receiver (garage door opener, etc.) operates with original hand-held transmitter.

Is the inspection result normal?

- YES >> GO TO 2.
NO >> Receiver or hand-held transmitter is malfunctioning.

2.CHECK ILLUMINATION

1. Turn ignition switch OFF.
2. Does red light of transmitter illuminate when any transmitter button is pressed?

Is the inspection result normal?

- YES >> GO TO 3.
NO >> Refer to [DLK-121, "Diagnosis Procedure"](#).

3.CHECK TRANSMITTER

Check transmitter with Tool*.

*:For details, refer to Technical Service Bulletin.

Is the inspection result normal?

- YES >> Receiver or hand-held transmitter malfunction, not vehicle related.
NO >> Replace auto anti-dazzling inside mirror (HomeLink® universal transceiver). Refer to [MIR-20, "Removal and Installation"](#).

Diagnosis Procedure

INFOID:000000013037191

Regarding Wiring Diagram information, refer to [DLK-54, "Wiring Diagram"](#).

1.CHECK POWER SUPPLY

1. Turn ignition switch OFF.
2. Disconnect auto anti-dazzling inside mirror (HomeLink® universal transceiver) connector.
3. Check voltage between auto anti-dazzling inside mirror (HomeLink® universal transceiver) harness connector and ground.

Auto anti-dazzling inside mirror (HomeLink® universal transceiver) connector	Terminal		Condition	Voltage (V) (Approx.)
R7	10	Ground	Ignition switch position: OFF	Battery voltage
	5		Ignition switch position: ON	

Is the inspection result normal?

- YES >> GO TO 2.
NO >> Check the following items:
- 5A fuse No. 14 located in the fuse block (J/B).
 - Harness for open or short between fuse and auto anti-dazzling inside mirror (HomeLink® universal transceiver).

2.CHECK GROUND CIRCUIT

Check continuity between auto anti-dazzling inside mirror (HomeLink® universal transceiver) harness connector and ground.

A
B
C
D
E
F
G
H
I
J
L
M
N
O
P

DLK

INTEGRATED HOMELINK TRANSMITTER

< DTC/CIRCUIT DIAGNOSIS >

Auto anti-dazzling inside mirror (HomeLink® universal transceiver) connector	Terminal	Ground	Continuity
R7	8		Yes

Is the inspection result normal?

YES >> GO TO 3.

NO >> Repair harness.

3.CHECK INTERMITTENT INCIDENT

Refer to [GI-43, "Intermittent Incident"](#).

>> Inspection End.

INTELLIGENT KEY SYSTEM SYMPTOMS

< SYMPTOM DIAGNOSIS >

SYMPTOM DIAGNOSIS

INTELLIGENT KEY SYSTEM SYMPTOMS

Diagnosis Procedure

INFOID:0000000013190755

NOTE:

Perform the self-diagnosis with CONSULT before the symptom diagnosis. Perform the trouble diagnosis if any DTC is detected.

SYMPTOM TABLE 1 (BOTH INTELLIGENT KEYS HAVE THE SAME SYMPTOMS)

No.	Door lock operation (remote keyless entry)	Door lock operation (request switch)	Engine started with push-button ignition switch operation (registered Intelligent Key is within the detection area of inside key antenna)	Engine started with push-button ignition switch operation (registered Intelligent Key placed next to push-button ignition switch)	Symptom
1	OK	OK	No start	No start	SEC-145
2	OK	NG	OK	OK	DLK-124
3	OK	NG	No crank, No start	OK	DLK-126
4	NG	NG	No crank, No start	OK	DLK-128
5	NG	NG	No start	No start	DLK-129
6	OK	OK	No crank, No start	OK	SEC-145
7	NG	OK	OK	OK	DLK-131
8	NG	NG	OK	OK	DLK-132
9	Poor range	OK	OK	OK	DLK-133

SYMPTOM TABLE 2 (ONE INTELLIGENT KEY HAS THE SYMPTOM, OTHER KEYS OPERATE NORMALLY)

No.	Door lock operation (remote keyless entry)	Door lock operation (request switch)	Engine started with push-button ignition switch operation (Intelligent Key is within the detection area of inside key antenna)	Engine started with push-button ignition switch operation (registered Intelligent Key placed next to push-button ignition switch)	Symptom
1	NG	OK	OK	OK	DLK-135
2	NG	NG	No crank, No start	OK	DLK-136
3	NG	NG	No crank, No start	No crank, No start	DLK-138
4	OK	OK	No crank, No start	No crank, No start	SEC-145
5	OK	NG	No crank, No start	OK	SEC-145
6	Poor range	OK	OK	OK	DLK-140

DLK

ALL DOORS DO NOT LOCK/UNLOCK OR TRUNK/BACK DOOR DO NOT OPEN WITH REQUEST SWITCH

< SYMPTOM DIAGNOSIS >

ALL DOORS DO NOT LOCK/UNLOCK OR TRUNK/BACK DOOR DO NOT OPEN WITH REQUEST SWITCH

Description

INFOID:000000013190756

All doors do not lock/unlock using front door request switch.

NOTE:

Before starting diagnosis check that vehicle condition is as shown in "Conditions of vehicle", and check each symptom.

SYMPTOM TABLE (BOTH INTELLIGENT KEYS HAVE THE SAME SYMPTOMS)

Door lock operation (remote keyless entry)	Door lock operation (request switch)	Engine started with push-button ignition switch operation (registered Intelligent Key is within the detection area of inside key antenna)	Engine started with push-button ignition switch operation (registered Intelligent Key placed next to push-button ignition switch)
OK	NG	OK	OK

CONDITIONS OF VEHICLE (OPERATING CONDITIONS)

- "LOCK/UNLOCK BY I-KEY" setting in "Work support" mode of "INTELLIGENT KEY" of "BCM" is ON.
- Registered Intelligent Key is within the detection area of outside key antenna.

DIAGNOSIS PROCEDURE

Refer to [DLK-124. "Diagnosis Procedure"](#).

Diagnosis Procedure

INFOID:000000013190757

1. CHECK INTELLIGENT KEY SYSTEM SYMPTOM TABLE

Check Intelligent Key system symptom table.

Refer to [DLK-123. "Diagnosis Procedure"](#).

>> GO TO 2.

2. PERFORM SELF-DIAGNOSIS RESULT

Select "Self Diagnostic Result" mode of "BCM", and check if DTC is detected.

Is DTC detected?

YES >> Perform the trouble diagnosis for detected DTC.

NO >> GO TO 3.

3. CHECK OUTSIDE KEY ANTENNA

Use SIGNAL TECH II to check each outside key antenna. For the inspection method and how to use SIGNAL TECH II, refer to "NISSAN/INFINITI SIGNAL TECH II USER GUIDE".

Is the inspection result normal?

YES >> GO TO 4.

NO >> GO TO 5.

4. CHECK INTELLIGENT KEY OUTPUT SIGNAL

Use SIGNAL TECH II to check Intelligent Key outside signal. For the inspection method and how to use SIGNAL TECH II, refer to "NISSAN/INFINITI SIGNAL TECH II USER GUIDE".

Is the inspection result normal?

YES >> GO TO 6.

NO >> Replace the malfunctioning outside key antenna. Refer to [DLK-185. "OUTSIDE HANDLE : Removal and Installation"](#).

5. CHECK DOOR REQUEST SWITCH

Check each door request switch.

- Front door: Refer to [DLK-96. "Component Function Check"](#).

ALL DOORS DO NOT LOCK/UNLOCK OR TRUNK/BACK DOOR DO NOT OPEN WITH REQUEST SWITCH

< SYMPTOM DIAGNOSIS >

Is the inspection result normal?

YES >> GO TO 6.

NO >> Repair or replace the malfunctioning parts. Refer to [DLK-169. "OUTSIDE HANDLE : Removal and Installation"](#).

6. REPLACE BCM

1. Replace BCM. Refer to [BCS-79. "Removal and Installation"](#).

2. Check operation after replacement.

Is the inspection result normal?

YES >> Inspection End.

NO >> Check intermittent incident. Refer to [GI-43. "Intermittent Incident"](#).

A

B

C

D

E

F

G

H

I

J

DLK

L

M

N

O

P

DOOR DOES NOT LOCK/UNLOCK AND ENGINE DOES NOT START (REQ SW/PUSH SW) (ALL KEYS)

< SYMPTOM DIAGNOSIS >

DOOR DOES NOT LOCK/UNLOCK AND ENGINE DOES NOT START (REQ SW/PUSH SW) (ALL KEYS)

Description

INFOID:000000013190758

All doors do not lock/unlock using door request switch, and engine does not start when push-button ignition switch is pressed while carrying Intelligent Key.

NOTE:

Before starting diagnosis check that vehicle condition is as shown in "Conditions of vehicle", and check each symptom.

SYMPTOM TABLE (BOTH INTELLIGENT KEYS HAVE THE SAME SYMPTOMS)

Door lock operation (remote keyless entry)	Door lock operation (request switch)	Engine started with push-button ignition switch operation (registered Intelligent Key is within the detection area of inside key antenna)	Engine started with push-button ignition switch operation (registered Intelligent Key placed next to push-button ignition switch)
OK	NG	No crank, No start	OK

CONDITIONS OF VEHICLE (OPERATING CONDITIONS)

- "LOCK/UNLOCK BY I-KEY" setting in "Work support" mode of "INTELLIGENT KEY" of "BCM" is ON.
- "ENGINE START BY I-KEY" setting in "Work support" mode of "INTELLIGENT KEY" of "BCM" is ON.

DIAGNOSIS PROCEDURE

Refer to [DLK-126, "Diagnosis Procedure"](#).

Diagnosis Procedure

INFOID:000000013190759

1. CHECK INTELLIGENT KEY SYSTEM SYMPTOM TABLE

Check Intelligent Key system symptom table.

Refer to [DLK-123, "Diagnosis Procedure"](#).

>> GO TO 2.

2. CHECK OUTSIDE KEY ANTENNA AND INSIDE KEY ANTENNA

Use SIGNAL TECH II to check each outside key antenna and inside key antenna. For the inspection method and how to use SIGNAL TECH II, refer to "NISSAN/INFINITI SIGNAL TECH II USER GUIDE".

Is the inspection result normal?

YES >> GO TO 3.

NO >> Repair or replace the malfunctioning parts.

3. REGISTER INTELLIGENT KEY

1. Register the Intelligent Key again.
2. Check operation after replacement.

Is the inspection result normal?

YES >> Inspection End.

NO >> GO TO 4.

4. REPLACE INTELLIGENT KEY

1. Replace the Intelligent Key and perform registration again.
2. Check operation after replacement.

Is the inspection result normal?

YES >> Inspection End.

NO >> GO TO 5.

5. REPLACE BCM

1. Replace BCM. Refer to [BCS-79, "Removal and Installation"](#).

DOOR DOES NOT LOCK/UNLOCK AND ENGINE DOES NOT START (REQ SW/ PUSH SW) (ALL KEYS)

< SYMPTOM DIAGNOSIS >

2. Check operation after replacement.

Is the inspection result normal?

YES >> Inspection End.

NO >> Check intermittent incident. Refer to [GI-43. "Intermittent Incident"](#).

A

B

C

D

E

F

G

H

I

J

DLK

L

M

N

O

P

DOOR DOES NOT LOCK/UNLOCK AND ENGINE DOES NOT START (ALL I-KEY/REQ SW/PUSH SW)

< SYMPTOM DIAGNOSIS >

DOOR DOES NOT LOCK/UNLOCK AND ENGINE DOES NOT START (ALL I-KEY/REQ SW/PUSH SW)

Description

INFOID:000000013190760

All doors do not lock/unlock using door request switch, Intelligent Key, and engine does not start when push-button ignition switch is pressed while carrying Intelligent Key.

SYMPTOM TABLE (BOTH INTELLIGENT KEYS HAVE THE SAME SYMPTOMS)

Door lock operation (remote keyless entry)	Door lock operation (request switch)	Engine started with push-button ignition switch operation (registered Intelligent Key is within the detection area of inside key antenna)	Engine started with push-button ignition switch operation (registered Intelligent Key placed next to push-button ignition switch)
NG	NG	No crank, No start	OK

CONDITIONS OF VEHICLE (OPERATING CONDITIONS)

"ENGINE START BY I-KEY" setting in "Work support" mode of "INTELLIGENT KEY" of "BCM" is ON.

DIAGNOSIS PROCEDURE

Refer to [DLK-128. "Diagnosis Procedure"](#).

Diagnosis Procedure

INFOID:000000013190761

1. CHECK INTELLIGENT KEY SYSTEM SYMPTOM TABLE

Check Intelligent Key system symptom table.

Refer to [DLK-123. "Diagnosis Procedure"](#).

>> GO TO 2.

2. PERFORM SELF-DIAGNOSIS RESULT

Select "Self Diagnostic Result" mode of "BCM", and check if DTC "B26FF" is detected.

Is DTC "B26FF" detected?

YES >> Perform the trouble diagnosis for detected DTC.

NO >> GO TO 3.

3. CHECK INTELLIGENT KEY BATTERY

Check Intelligent Key battery.

Refer to [DLK-115. "Component Function Check"](#).

Is the inspection result normal?

YES >> GO TO 4.

NO >> Repair or replace the malfunctioning parts. Refer to [DLK-189. "Removal and Installation"](#).

4. CHECK REMOTE KEYLESS ENTRY RECEIVER

Check remote keyless entry receiver.

Refer to [DLK-109. "Diagnosis Procedure"](#).

Is the inspection result normal?

YES >> GO TO 5.

NO >> Repair or replace the malfunctioning parts. Refer to [DLK-188. "Removal and Installation"](#).

5. REPLACE BCM

1. Replace BCM. Refer to [BCS-79. "Removal and Installation"](#).

2. Check operation after replacement.

Is the inspection result normal?

YES >> Inspection End.

NO >> Check intermittent incident. Refer to [GI-43. "Intermittent Incident"](#).

INTELLIGENT KEY SYSTEM ALL FUNCTIONS CANNOT OPERATE (ALL KEYS)

< SYMPTOM DIAGNOSIS >

INTELLIGENT KEY SYSTEM ALL FUNCTIONS CANNOT OPERATE (ALL KEYS)

Description

INFOID:000000013190762

Intelligent Key system all functions cannot operate (door lock and engine start).

SYMPTOM TABLE (BOTH INTELLIGENT KEYS HAVE THE SAME SYMPTOMS)

Door lock operation (remote keyless entry)	Door lock operation (request switch)	Engine started with push-button ignition switch operation (registered Intelligent Key is within the detection area of inside key antenna)	Engine started with push-button ignition switch operation (registered Intelligent Key placed next to push-button ignition switch)
NG	NG	No start	No start

CONDITIONS OF VEHICLE (OPERATING CONDITIONS)

“ENGINE START BY I-KEY” setting in “Work support” mode of “INTELLIGENT KEY” of “BCM” is ON.

DIAGNOSIS PROCEDURE

Refer to [DLK-129, "Diagnosis Procedure"](#).

Diagnosis Procedure

INFOID:000000013190763

1.CHECK INTELLIGENT KEY SYSTEM SYMPTOM TABLE

Check Intelligent Key system symptom table.

Refer to [DLK-123, "Diagnosis Procedure"](#).

>> GO TO 2.

2.CHECK INTELLIGENT KEY-1

For both Intelligent Key that cannot be used for door lock and unlock, check that the Intelligent Key belongs to the vehicle to be checked.

- Check if the Intelligent Key that is checked is the Intelligent Key for a different NISSAN/INFINITI vehicle that the user owns.
- Check that the Intelligent Key buttons match the vehicle specifications.

Does the Intelligent Key belong to the vehicle to be checked?

YES >> GO TO 3.

NO >> Check Intelligent Key button operation using a registered Intelligent Key that belongs to the vehicle.

3.CHECK INTELLIGENT KEY-2

Check the inside of the both Intelligent Keys for rust or corrosion by water. Simultaneously check the internal circuits for damage.

Is the inspection result normal?

YES >> GO TO 4.

NO >> Replace Intelligent Key.

4.REGISTER INTELLIGENT KEY

1. Register the Intelligent Key again.
2. Check operation after replacement.

Is the inspection result normal?

YES >> Inspection End.

NO >> GO TO 5.

5.REPLACE INTELLIGENT KEY

1. Replace the Intelligent Key and perform registration again.
2. Check operation after replacement.

A
B
C
D
E
F
G
H
I
J
L
M
N
O
P

DLK

INTELLIGENT KEY SYSTEM ALL FUNCTIONS CANNOT OPERATE (ALL KEYS)

< SYMPTOM DIAGNOSIS >

Is the inspection result normal?

YES >> Inspection End.

NO >> GO TO 6.

6. REPLACE BCM

1. Replace BCM. Refer to [BCS-79, "Removal and Installation"](#).

2. Check the operation after replacement.

Is the inspection result normal?

YES >> Inspection End

NO >> Check intermittent incident. Refer to [GI-43, "Intermittent Incident"](#).

DOOR DOES NOT LOCK/UNLOCK WITH INTELLIGENT KEY

< SYMPTOM DIAGNOSIS >

DOOR DOES NOT LOCK/UNLOCK WITH INTELLIGENT KEY

Description

INFOID:000000013190764

All doors do not lock/unlock using Intelligent Key button.

NOTE:

Before starting diagnosis check that vehicle condition is as shown in "Conditions of vehicle", and check each symptom.

SYMPTOM TABLE (BOTH INTELLIGENT KEYS HAVE THE SAME SYMPTOMS)

Door lock operation (remote keyless entry)	Door lock operation (request switch)	Engine started with push-button ignition switch operation (registered Intelligent Key is within the detection area of inside key antenna)	Engine started with push-button ignition switch operation (registered Intelligent Key placed next to push-button ignition switch)
NG	OK	OK	OK

CONDITIONS OF VEHICLE (OPERATING CONDITIONS)

Registered Intelligent Key is within the detection area of remote keyless entry receiver.

DIAGNOSIS PROCEDURE

Refer to [DLK-131. "Diagnosis Procedure"](#).

Diagnosis Procedure

INFOID:000000013190765

1. CHECK INTELLIGENT KEY SYSTEM SYMPTOM TABLE

Check Intelligent Key system symptom table.

Refer to [DLK-123. "Diagnosis Procedure"](#).

>> GO TO 2.

2. CHECK INTELLIGENT KEY OUTPUT SIGNAL

Use SIGNAL TECH II to check Intelligent Key output signal. For the inspection method and how to use SIGNAL TECH II, refer to "NISSAN/INFINITI SIGNAL TECH II USER GUIDE".

Is the inspection result normal?

YES >> Replace BCM. Refer to [BCS-79. "Removal and Installation"](#).

NO >> Replace Intelligent Key.

A
B
C
D
E
F
G
H
I
J
L
M
N
O
P

DLK

DOOR DOES NOT LOCK/UNLOCK WITH DOOR REQUEST SWITCH AND INTELLIGENT KEY

< SYMPTOM DIAGNOSIS >

DOOR DOES NOT LOCK/UNLOCK WITH DOOR REQUEST SWITCH AND INTELLIGENT KEY

Description

INFOID:000000013190766

All doors do not lock/unlock using door request switch or Intelligent Key button.

SYMPTOM TABLE (BOTH INTELLIGENT KEYS HAVE THE SAME SYMPTOMS)

Door lock operation (remote keyless entry)	Door lock operation (request switch)	Engine started with push-button ignition switch operation (registered Intelligent Key is within the detection area of inside key antenna)	Engine started with push-button ignition switch operation (registered Intelligent Key placed next to push-button ignition switch)
NG	NG	OK	OK

DIAGNOSIS PROCEDURE

Refer to [DLK-132, "Diagnosis Procedure"](#).

Diagnosis Procedure

INFOID:000000013190767

1. CHECK INTELLIGENT KEY SYSTEM SYMPTOM TABLE

Check Intelligent Key system symptom table.

Refer to [DLK-123, "Diagnosis Procedure"](#).

>> GO TO 2.

2. CHECK POWER DOOR LOCK OPERATION

Check door lock/unlock using door lock and unlock switch.

Does door lock/unlock using door lock and unlock switch?

YES >> GO TO 3.

NO >> Refer to [DOOR DOES NOT LOCK/UNLOCK WITH DOOR LOCK AND UNLOCK SWITCH].

3. REPLACE BCM

1. Replace BCM. Refer to [BCS-79, "Removal and Installation"](#).

2. Check operation after replacement.

Is the inspection result normal?

YES >> Inspection End.

NO >> Check intermittent incident. Refer to [GI-43, "Intermittent Incident"](#).

INTELLIGENT KEY BUTTON OPERATION HAS POOR RANGE (ALL KEYS)

< SYMPTOM DIAGNOSIS >

INTELLIGENT KEY BUTTON OPERATION HAS POOR RANGE (ALL KEYS)

Description

INFOID:000000013190768

Intelligent Key button operation has poor range.

SYMPTOM TABLE (BOTH INTELLIGENT KEYS HAVE THE SAME SYMPTOMS)

Door lock operation (remote keyless entry)	Door lock operation (request switch)	Engine started with push-button ignition switch operation (registered Intelligent Key is within the detection area of inside key antenna)	Engine started with push-button ignition switch operation (registered Intelligent Key placed next to push-button ignition switch)
Poor range	OK	OK	OK

DIAGNOSIS PROCEDURE

Refer to [DLK-133, "Diagnosis Procedure"](#).

Diagnosis Procedure

INFOID:000000013190769

1. CHECK INTELLIGENT KEY SYSTEM SYMPTOM TABLE

Check Intelligent Key system symptom table.
Refer to [DLK-123, "Diagnosis Procedure"](#).

>> GO TO 2.

2. CHECK INTELLIGENT KEY LOW BATTERY WARNING

Check that the Intelligent Key low battery warning operates.

Is the Intelligent Key low battery warning operated?

YES >> GO TO 3.

NO >> Replace Intelligent Key battery. Refer to [DLK-189, "Removal and Installation"](#).

3. CHECK INTELLIGENT KEY BATTERY

Check the Intelligent Key battery.

Refer to [DLK-115, "Component Function Check"](#).

Is the inspection result normal?

YES >> GO TO 4.

NO >> Replace Intelligent Key battery. Refer to [DLK-189, "Removal and Installation"](#).

4. PERFORM SELF-DIAGNOSIS RESULT-1

Select "Self Diagnostic Result" mode of "BCM", and check if DTC "B26FF" is detected.

Is DTC "B26FF" detected?

YES >> Perform the trouble diagnosis for detected DTC.

NO >> GO TO 5.

5. REMOTE AFTERMARKET DEVICE

1. If the vehicle is equipped with any interference-generating aftermarket device such as a vehicle security system, charger and remote engine starter etc., remove them.
2. Check operation after replacement.

Is the inspection result normal?

YES >> Inspection End.

NO >> GO TO 6.

6. CHECK REMOTE KEYLESS ENTRY RECEIVER

Check remote keyless entry receiver.

Refer to [DLK-109, "Diagnosis Procedure"](#).

Is the inspection result normal?

YES >> GO TO 7.

A
B
C
D
E
F
G
H
I
J
L
M
N
O
P

DLK

INTELLIGENT KEY BUTTON OPERATION HAS POOR RANGE (ALL KEYS)

< SYMPTOM DIAGNOSIS >

NO >> Repair or replace the malfunctioning parts.

7. REPLACE BCM

1. Replace BCM. Refer to [BCS-79, "Removal and Installation"](#).

2. Check operation after replacement.

Is the inspection result normal?

YES >> Inspection End.

NO >> Check intermittent incident. Refer to [GI-43, "Intermittent Incident"](#).

DOOR DOES NOT LOCK/UNLOCK WITH INTELLIGENT KEY (ONE KEY)

< SYMPTOM DIAGNOSIS >

DOOR DOES NOT LOCK/UNLOCK WITH INTELLIGENT KEY (ONE KEY)

Description

INFOID:000000013190770

All doors do not lock/unlock using Intelligent Key button. (One Intelligent Key has the symptom, other keys operate normally.)

NOTE:

Before starting diagnosis check that vehicle condition is as shown in "Conditions of vehicle", and check each symptom.

SYMPTOM TABLE (ONE INTELLIGENT KEY HAS THE SYMPTOM, OTHER KEYS OPERATE NORMALLY)

Door lock operation (remote keyless entry)	Door lock operation (request switch)	Engine started with push-button ignition switch operation (Intelligent Key is within the detection area of inside key antenna)	Engine started with push-button ignition switch operation (registered Intelligent Key placed next to push-button ignition switch)
NG	OK	OK	OK

DIAGNOSIS PROCEDURE

Refer to [DLK-135. "Diagnosis Procedure"](#).

Diagnosis Procedure

INFOID:000000013190771

1. CHECK INTELLIGENT KEY SYSTEM SYMPTOM TABLE

Check Intelligent Key system symptom table.

Refer to [DLK-123. "Diagnosis Procedure"](#).

>> GO TO 2.

2. CHECK INTELLIGENT KEY OUTPUT SIGNAL

Use SIGNAL TECH II to check Intelligent Key output signal. For the inspection method and how to use SIGNAL TECH II, refer to "NISSAN/INFINITI SIGNAL TECH II USER GUIDE".

Is the inspection result normal?

YES >> GO TO 3.

NO >> Replace Intelligent Key.

3. REGISTER INTELLIGENT KEY

1. Register the Intelligent Key again.
2. Check operation after replacement.

Is the inspection result normal?

YES >> Inspection End.

NO >> GO TO 4.

4. REPLACE INTELLIGENT KEY

1. Replace the Intelligent Key and perform registration again.
2. Check operation after replacement.

Is the inspection result normal?

YES >> Inspection End.

NO >> GO TO 5.

5. REPLACE BCM

1. Replace BCM. Refer to [BCS-79. "Removal and Installation"](#).
2. Check operation after replacement.

Is the inspection result normal?

YES >> Inspection End.

NO >> Check intermittent incident. Refer to [GI-43. "Intermittent Incident"](#).

A
B
C
D
E
F
G
H
I
J
L
M
N
O
P

DLK

DOOR DOES NOT LOCK/UNLOCK AND ENGINE DOES NOT START (ONE I-KEY/REQ SW/PUSH SW)

< SYMPTOM DIAGNOSIS >

DOOR DOES NOT LOCK/UNLOCK AND ENGINE DOES NOT START (ONE I-KEY/REQ SW/PUSH SW)

Description

INFOID:000000013190772

All doors do not lock/unlock using door request switch or Intelligent Key, and engine does not start when push-button ignition switch is pressed while carrying Intelligent Key. (One Intelligent Key has the symptom, other keys operate normally.)

SYMPTOM TABLE (ONE INTELLIGENT KEY HAS THE SYMPTOM, OTHER KEYS OPERATE NORMALLY)

Door lock operation (remote keyless entry)	Door lock operation (request switch)	Engine started with push-button ignition switch operation (Intelligent Key is within the detection area of inside key antenna)	Engine started with push-button ignition switch operation (registered Intelligent Key placed next to push-button ignition switch)
NG	NG	No crank, No start	OK

DIAGNOSIS PROCEDURE

Refer to [DLK-136. "Diagnosis Procedure"](#).

Diagnosis Procedure

INFOID:000000013190773

1. CHECK INTELLIGENT KEY SYSTEM SYMPTOM TABLE

Check Intelligent Key system symptom table.

Refer to [DLK-123. "Diagnosis Procedure"](#).

>> GO TO 2.

2. CHECK INTELLIGENT KEY

Check the inside of the Intelligent Key for rust or corrosion by water. Simultaneously check the internal circuits for damage. Squeeze, twist or bend the Intelligent Key and check the functionality again. Is the Intelligent Key operating normally?

Is the inspection result normal?

YES >> GO TO 3.

NO >> Replace Intelligent Key.

3. CHECK INTELLIGENT KEY BATTERY

Check the Intelligent Key battery.

Is the inspection result normal?

YES >> GO TO 4.

NO >> Replace Intelligent Key battery. Refer to [DLK-189. "Removal and Installation"](#).

4. REGISTER INTELLIGENT KEY

1. Register the Intelligent Key again.
2. Check operation after replacement.

Is the inspection result normal?

YES >> Inspection End.

NO >> GO TO 5.

5. REPLACE INTELLIGENT KEY

1. Replace the Intelligent Key and perform registration again.
2. Check operation after replacement.

Is the inspection result normal?

YES >> Inspection End.

NO >> GO TO 6.

DOOR DOES NOT LOCK/UNLOCK AND ENGINE DOES NOT START (ONE I-KEY/REQ SW/PUSH SW)

< SYMPTOM DIAGNOSIS >

6. REPLACE BCM

1. Replace BCM. Refer to [BCS-79, "Removal and Installation"](#).
2. Confirm the operation after replacement.

Is the inspection result normal?

YES >> Inspection End.

NO >> Check intermittent incident. Refer to [GI-43, "Intermittent Incident"](#).

A
B
C
D
E
F
G
H
I
J
DLK
L
M
N
O
P

INTELLIGENT KEY SYSTEM ALL FUNCTIONS CANNOT OPERATE (ONE KEY)

< SYMPTOM DIAGNOSIS >

INTELLIGENT KEY SYSTEM ALL FUNCTIONS CANNOT OPERATE (ONE KEY)

Description

INFOID:000000013190774

Intelligent Key system all functions cannot operate (door lock and engine start). (One Intelligent Key has the symptom, other keys operate normally.)

SYMPTOM TABLE (ONE INTELLIGENT KEY HAS THE SYMPTOM, OTHER KEYS OPERATE NORMALLY)

Door lock operation (remote keyless entry)	Door lock operation (request switch)	Engine started with push-button ignition switch operation (Intelligent Key is within the detection area of inside key antenna)	Engine started with push-button ignition switch operation (registered Intelligent Key placed next to push-button ignition switch)
NG	NG	No crank, No start	No crank, No start

DIAGNOSIS PROCEDURE

Refer to [DLK-138. "Diagnosis Procedure"](#).

Diagnosis Procedure

INFOID:000000013190775

1. CHECK INTELLIGENT KEY SYSTEM SYMPTOM TABLE

Check Intelligent Key system symptom table.

Refer to [DLK-123. "Diagnosis Procedure"](#).

>> GO TO 2.

2. CHECK INTELLIGENT KEY-1

For Intelligent Key that cannot be used for door lock and unlock, check that the Intelligent Key belongs to the vehicle to be checked.

Does the Intelligent Key belong to the vehicle to be checked?

YES >> GO TO 3.

NO >> Check Intelligent Key button operation using a registered Intelligent Key that belongs to the vehicle.

3. CHECK INTELLIGENT KEY-2

Check the inside of the Intelligent Key for rust or corrosion by water. Simultaneously check the internal circuits for damage.

Is the inspection result normal?

YES >> GO TO 4.

NO >> Replace Intelligent Key.

4. REGISTER INTELLIGENT KEY

1. Register the Intelligent Key again.

2. Check the operation after replacement.

Is the inspection result normal?

YES >> Inspection End.

NO >> GO TO 5.

5. REPLACE INTELLIGENT KEY

1. Replace the Intelligent Key and perform registration again.

2. Check operation after replacement.

Is the inspection result normal?

YES >> Inspection End.

NO >> GO TO 6.

INTELLIGENT KEY SYSTEM ALL FUNCTIONS CANNOT OPERATE (ONE KEY)

< SYMPTOM DIAGNOSIS >

6. REPLACE BCM

1. Replace BCM. Refer to [BCS-79, "Removal and Installation"](#).
2. Check operation after replacement.

Is the inspection result normal?

YES >> Inspection End.

NO >> Check intermittent incident. Refer to [GI-43, "Intermittent Incident"](#).

A
B
C
D
E
F
G
H
I
J
DLK
L
M
N
O
P

INTELLIGENT KEY BUTTON OPERATION HAS POOR RANGE (ONE KEY)

< SYMPTOM DIAGNOSIS >

INTELLIGENT KEY BUTTON OPERATION HAS POOR RANGE (ONE KEY)

Description

INFOID:000000013190776

Intelligent Key button operation has poor range. (One Intelligent Key has the symptom, other keys operate normally.)

SYMPTOM TABLE (ONE INTELLIGENT KEY HAS THE SYMPTOM, OTHER KEYS OPERATE NORMALLY)

Door lock operation (remote keyless entry)	Door lock operation (request switch)	Engine started with push-button ignition switch operation (Intelligent Key is within the detection area of inside key antenna)	Engine started with push-button ignition switch operation (registered Intelligent Key placed next to push-button ignition switch)
Poor range	OK	OK	OK

DIAGNOSIS PROCEDURE

Refer to [DLK-140, "Diagnosis Procedure"](#).

Diagnosis Procedure

INFOID:000000013190777

1. CHECK INTELLIGENT KEY SYSTEM SYMPTOM TABLE

Check Intelligent Key system symptom table.

Refer to [DLK-123, "Diagnosis Procedure"](#).

>> GO TO 2.

2. CHECK INTELLIGENT KEY LOW BATTERY WARNING

Check that the Intelligent Key low battery warning operates.

Is the Intelligent Key low battery warning operated?

YES >> Replace Intelligent Key battery. Refer to [DLK-189, "Removal and Installation"](#).

NO >> GO TO 3.

3. CHECK INTELLIGENT KEY BATTERY

Check the Intelligent Key battery.

Is the inspection result normal?

YES >> Replace Intelligent Key and register new Intelligent Key.

NO >> Replace Intelligent Key battery. Refer to [DLK-189, "Removal and Installation"](#).

HOOD

< REMOVAL AND INSTALLATION >

REMOVAL AND INSTALLATION

HOOD

Exploded View

INFOID:000000013000147

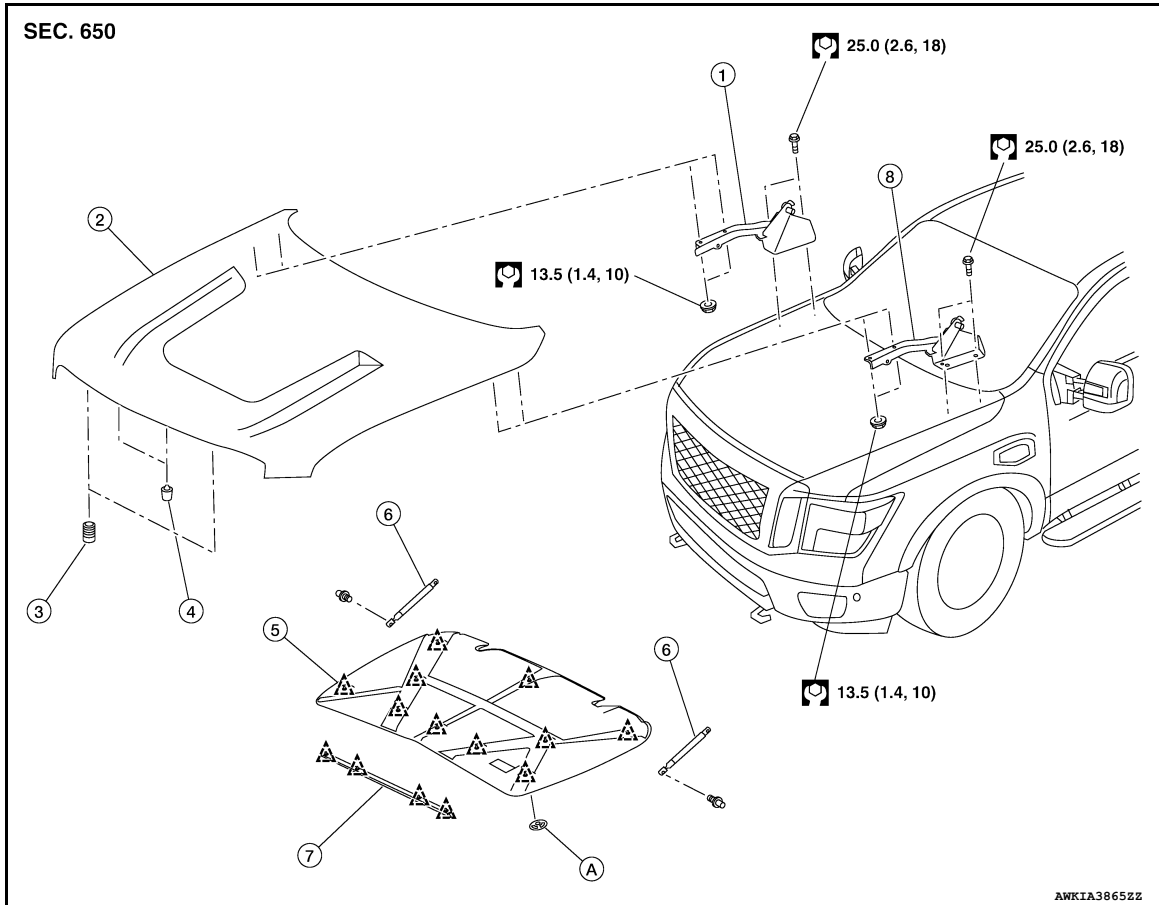

- | | | |
|----------------------------------|--------------------|--------------------------|
| 1. Hood hinge (RH) | 2. Hood | 3. Bumper rubber (LH/RH) |
| 4. Closing bumper rubber (LH/RH) | 5. Insulator | 6. Hood stay (LH/RH) |
| 7. Radiator core seal | 8. Hood hinge (LH) | A. Insulator clip |

HOOD ASSEMBLY

HOOD ASSEMBLY : Removal and Installation

INFOID:000000013000148

CAUTION:

- Use two people when removing or installing hood assembly due to its heavy weight.
- Use protective tape or shop cloths to protect surrounding components from damage during removal and installation of hood assembly.

REMOVAL

1. Support hood using a suitable tool.

WARNING:

Bodily injury may occur if hood assembly is not supported properly when removing hood assembly.

2. Remove hood insulator. Refer to [DLK-145. "HOOD INSULATOR : Removal and Installation"](#).
3. Remove hood radiator core seal. Refer to [DLK-144. "RADIATOR CORE SEAL : Removal and Installation"](#).

HOOD

< REMOVAL AND INSTALLATION >

4. Using suitable tool (A) release metal clip (3) as shown.

- (1) :Hood stay
- (2) :Stud ball

5. Separate hood stay from stud ball (hood side).

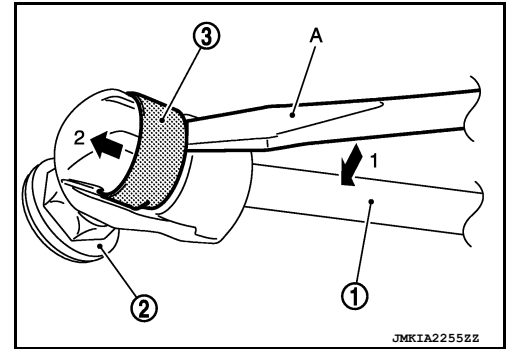

6. Remove hood hinge to hood nuts, and then remove hood.

INSTALLATION

Installation is in the reverse order of removal.

CAUTION:

- Before installing hood, apply anticorrosive agent to the hinge mating surface.
- After installing, perform hood fitting adjustment. Refer to [DLK-142, "HOOD ASSEMBLY : Adjustment"](#).
- Apply touch-up paint if the paint peeled off during procedure.

HOOD ASSEMBLY : Adjustment

INFOID:000000013000149

HOOD

< REMOVAL AND INSTALLATION >

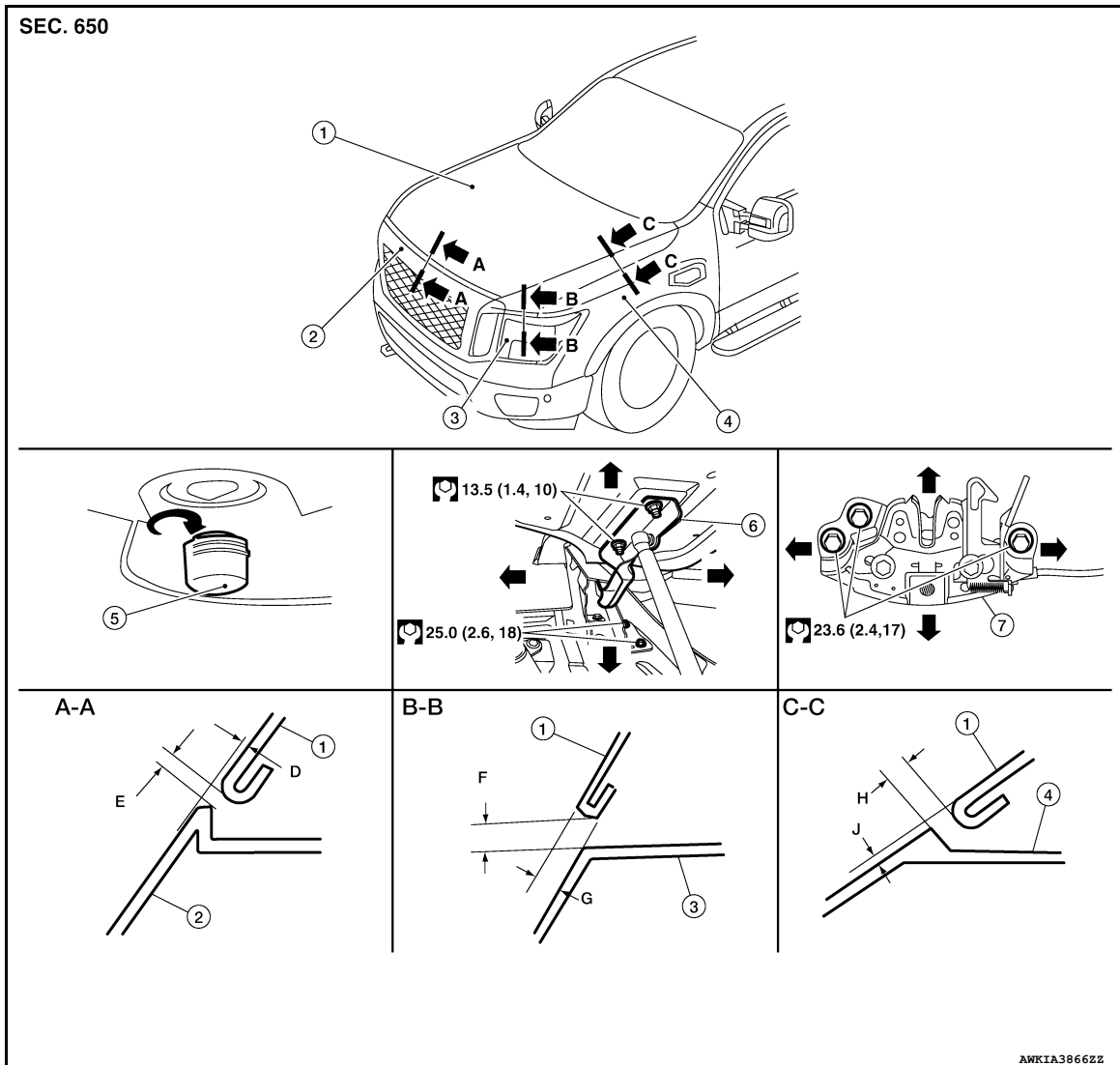

- | | | |
|--------------|------------------|---------------------------|
| 1. Hood | 2. Front grille | 3. Front combination lamp |
| 4. Fender | 5. Bumper rubber | 6. Hood hinge |
| 7. Hood lock | | |

Check the clearance and the surface height between hood and each part visually and by touching. If the clearance and the surface height are out of specification, adjust them according to the adjustment procedures.

Unit: mm (in)

Portion	Section	Item	Measurement	Standard	Parallelism
Hood - Front grill	A - A	D	Clearance	4.5 ± 2.0 (0.18 \pm 0.08)	2.0 (0.08)
		E	Surface height	$1.6 +1.6 -2.0$ (0.06 +0.06 -0.08)	2.0 (0.08)
Hood - Front combination lamp	B - B	F	Clearance	8.0 ± 2.0 (0.31 \pm 0.08)	2.0 (0.08)
		G	Surface Height	-	-
Hood - Fender	C - C	H	Clearance	4.0 ± 1.0 (0.16 \pm 0.04)	1.0 (0.04)
		J	Surface Height	0 ± 1.0 (0.04)	1.0 (0.04)

HEIGHT ADJUSTMENT

- Loosen hood lock bolts.
- Adjust surface height of hood to front grille and front fender according to specified values by rotating hood bumper rubber.

A
B
C
D
E
F
G
H
I
J

DLK

L
M
N
O
P

HOOD

< REMOVAL AND INSTALLATION >

- Temporarily tighten hood lock bolts.
- Adjust (A) and (B) as shown to the following values with hood's own weight by dropping it from approximately 200 mm (7.87 in) or by pressing hood lightly [approximately 29.4 N (3.0 kg, 6.61 lb)].

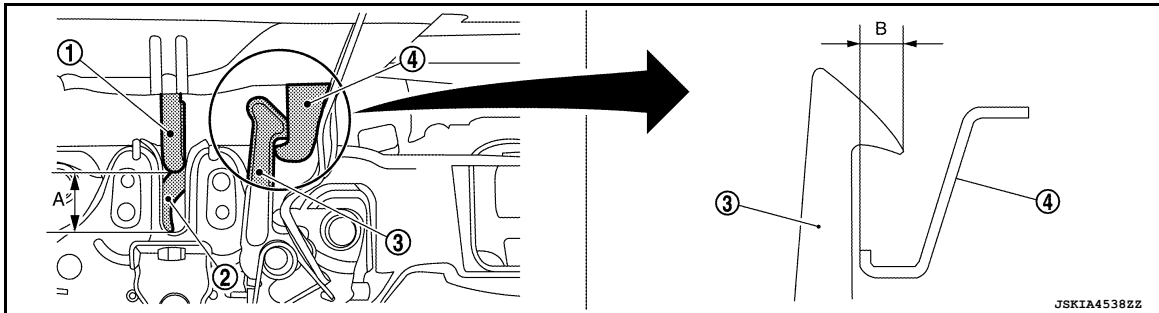

- | | | |
|----------------------|---------------------|---------------------|
| 1. Primary striker | 2. Primary latch | 3. Secondary latch |
| 4. Secondary striker | A. 20 mm (0.787 in) | B. 6.8 mm (0.27 in) |

- After adjustment, tighten hood lock bolts to specified torque.

CLEARANCE ADJUSTMENT

- Loosen hood hinge nuts and bolts.
- Loosen hood lock bolts.
- Adjust hood assembly so clearance measurements are within specifications.
- Tighten hood hinge nuts and bolts to specified torque.
- Tighten hood lock assembly bolts to specified torque.

HOOD HINGE

HOOD HINGE : Removal and Installation

INFOID:000000013000150

REMOVAL

- Remove hood assembly. Refer to [DLK-141, "HOOD ASSEMBLY : Removal and Installation"](#).
- Remove front fender. Refer to [DLK-149, "Removal and Installation"](#).
- Remove bolts, then remove hood hinge.

INSTALLATION

Installation is in the reverse order of removal.

CAUTION:

- Before installing the hood hinge, apply anticorrosive agent onto the mating surface.
- After installation, perform hood assembly adjustment procedure. Refer to [DLK-142, "HOOD ASSEMBLY : Adjustment"](#).

RADIATOR CORE SEAL

RADIATOR CORE SEAL : Removal and Installation

INFOID:000000013000152

REMOVAL

Release clips using suitable tool, and remove radiator core seal from hood. Refer to [DLK-141, "Exploded View"](#).

CAUTION:

Do not damage hood assembly.

INSTALLATION

Installation is in the reverse order of removal.

HOOD INSULATOR

HOOD

< REMOVAL AND INSTALLATION >

HOOD INSULATOR : Removal and Installation

INFOID:000000013000153

REMOVAL

Release insulator clips using suitable tool, then remove hood insulator from hood. Refer to [DLK-141](#), "[Exploded View](#)".

INSTALLATION

Installation is in the reverse order of removal.

HOOD STAY

HOOD STAY : Removal and Installation

INFOID:000000013000229

REMOVAL

1. Support hood using a suitable tool.

WARNING:

Bodily injury may occur if hood is not supported properly when removing hood stay.

2. Using suitable tool (A) release metal clip (3) as shown.

(1) :Hood stay

(2) :Stud ball

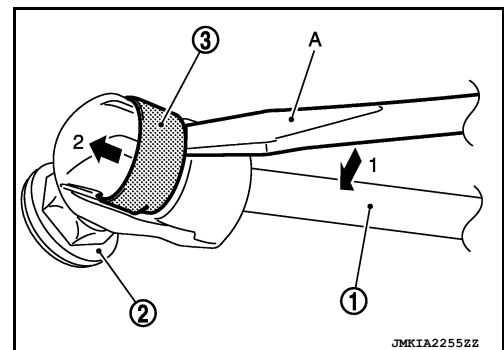

3. Separate hood stay from stud ball (hood side).

4. Separate hood stay from stud ball (body side) then remove hood stay.

INSTALLATION

Installation is in the reverse order of removal.

HOOD STAY : Disposal

INFOID:000000013000230

1. Fix hood stay (1) using a vise (C).

2. Using a hacksaw (A), slowly make two holes in hood stay (1) in numerical order as shown in figure.

CAUTION:

- When cutting a hole in hood stay (1), always cover hacksaw (A) with a shop cloth (B) to avoid scattering metal fragments or oil.
- Wear eye protection (safety glasses).
- Wear gloves.

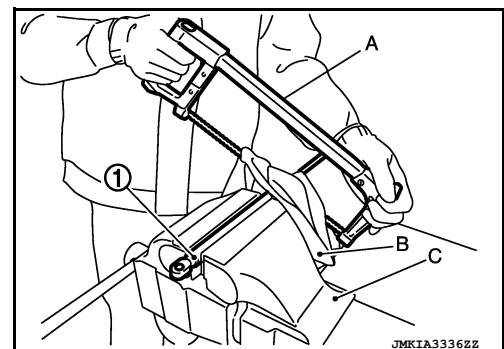

A
B
C
D
E
F
G
H
I
J
DLK
L
M
N
O
P

HOOD

< REMOVAL AND INSTALLATION >

A: 20 mm (0.79 in)

B: Cut at groove.

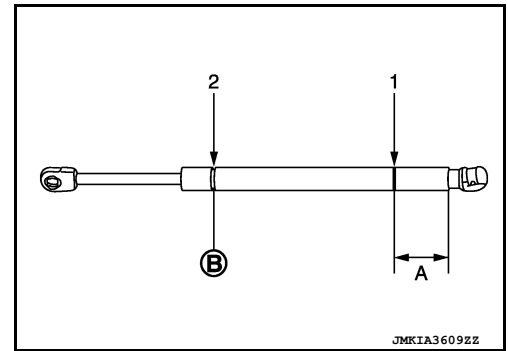

RADIATOR CORE SUPPORT

< REMOVAL AND INSTALLATION >

RADIATOR CORE SUPPORT

Exploded View

INFOID:000000013000156

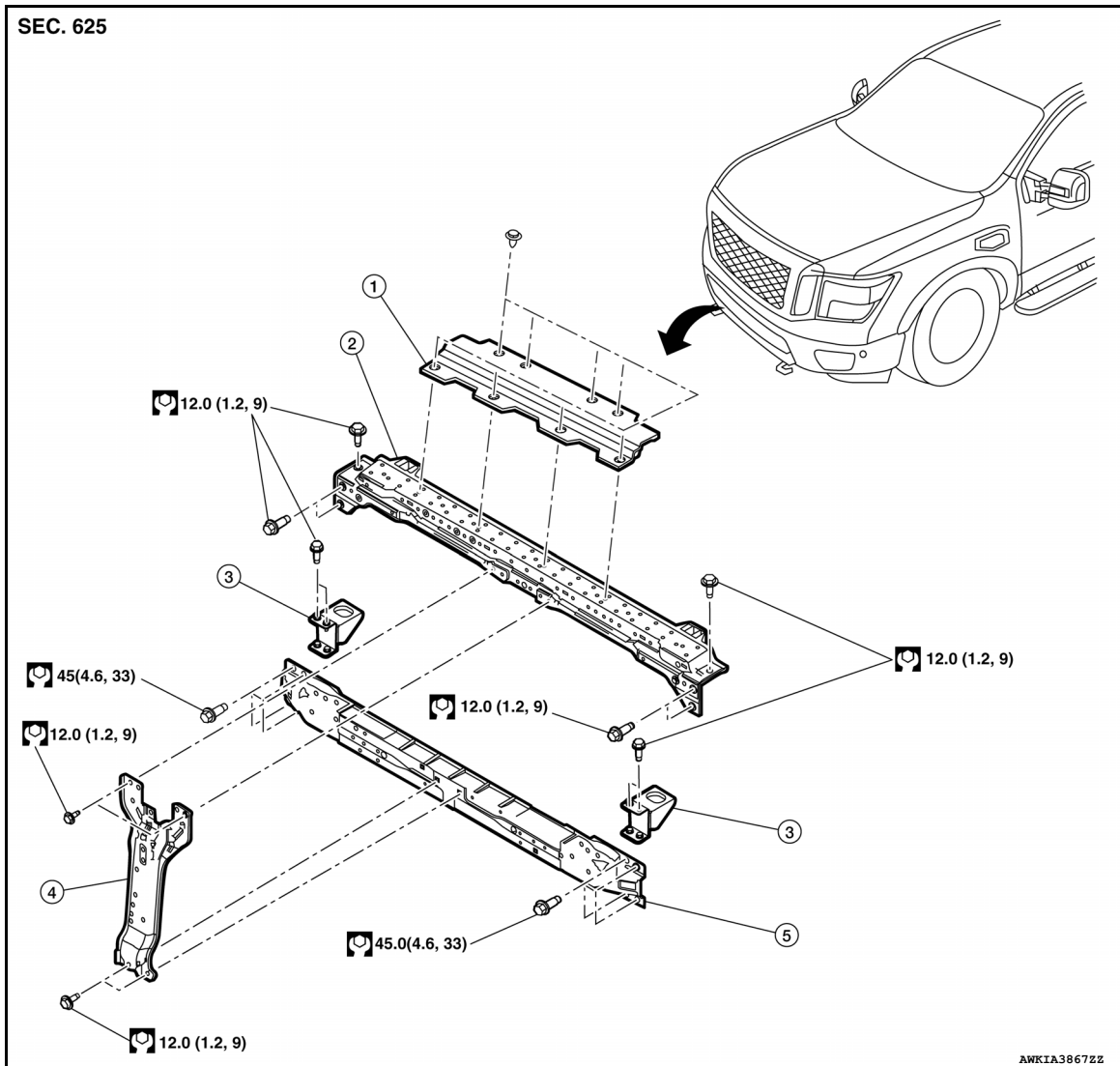

- | | | |
|--------------------------------|----------------------------------|--------------------------|
| 1. Radiator core support cover | 2. Radiator core support | 3. Bracket lower (LH/RH) |
| 4. Hood lock support stay | 5. Radiator core support bracket | |

Removal and Installation

INFOID:000000013000157

REMOVAL

1. Remove front combination lamp. Refer to [EXL-289, "Removal and Installation"](#) (LED HEADLAMP), or [EXL-132, "Removal and Installation"](#) (HALOGEN HEADLAMP).

RADIATOR CORE SUPPORT

< REMOVAL AND INSTALLATION >

2. Remove radiator bolts (A).
3. Remove intercooler bolts [B (if equipped)].

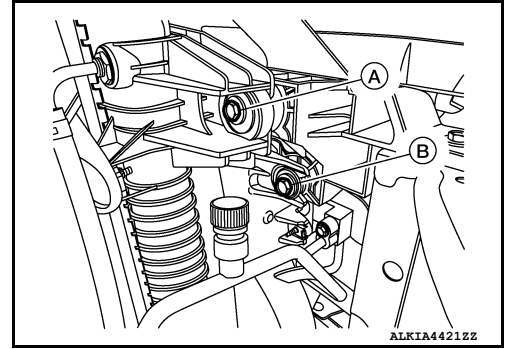

4. Remove hood lock bolts. Refer to [DLK-165, "HOOD LOCK : Removal and Installation"](#).
5. Remove horn. Refer to [HRN-7, "Removal and Installation"](#).
6. Release clips using suitable tool and remove radiator core support cover.
7. Remove upper clips from air guide.
8. For models equipped with VK56VD engine remove A/T fluid cooler bolts (A).

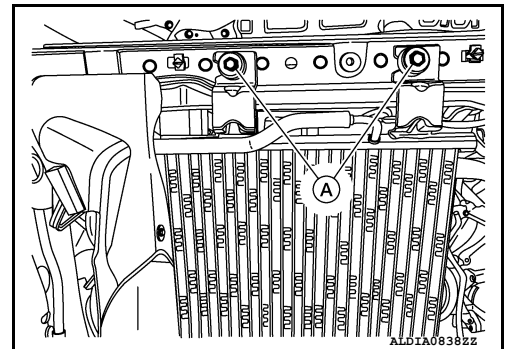

9. Remove hood lock support stay bolts (A).

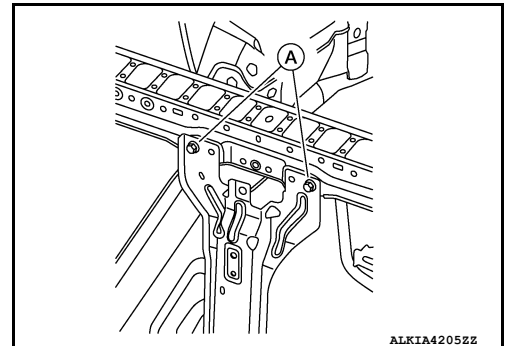

10. Remove bolts and radiator core support.
11. Remove remaining clips then air guide [LH/RH (if necessary)].
12. Remove clips then lower air guide (if necessary).
13. Remove bolts then lower bracket [LH/RH (if necessary)].

INSTALLATION

Installation is in the reverse order of removal.

FRONT FENDER



< REMOVAL AND INSTALLATION >

FRONT FENDER

Exploded View

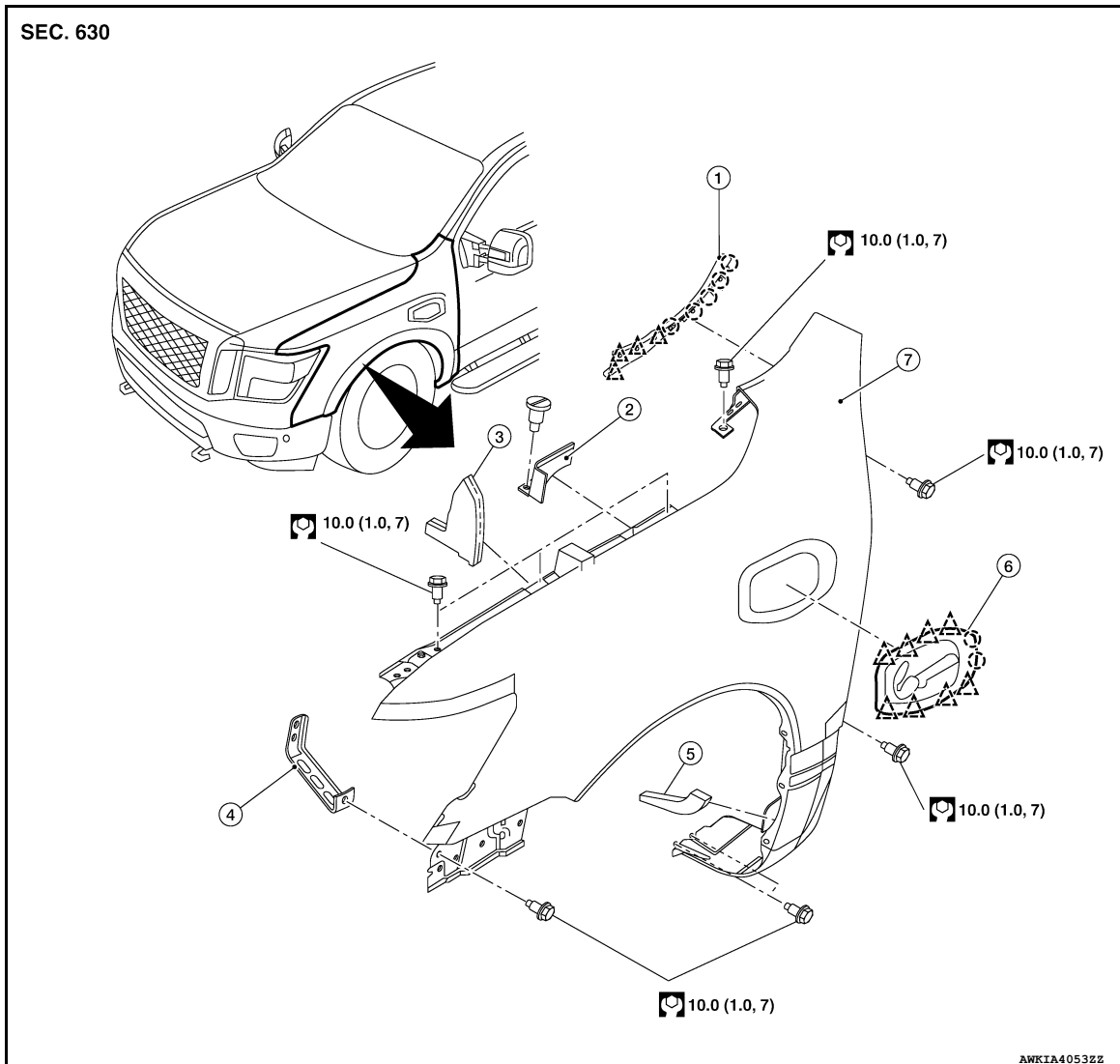
INFOID:000000013000158



- | | | |
|--------------------------|--|--|
| 1. Cowl top fender cover | 2. Front fender cover (RH) | 3. Front fender baffle |
| 4. Front fender bracket | 5. Front fender insulator | 6. Emblem |
| 7. Front fender |  Clip |  Pawl |

Removal and Installation

INFOID:000000013000159

REMOVAL

1. Remove front combination lamp. Refer to [EXL-289. "Removal and Installation"](#) (LED HEADLAMP), or [EXL-132. "Removal and Installation"](#) (HALOGEN HEADLAMP).
2. Remove fender protector. Refer to [EXT-32. "Removal and Installation - Front Fender Protector"](#).
3. Remove cowl top fender cover. Refer to [EXT-26. "Removal and Installation - Cowl Top Cover"](#).
4. Remove front fender bolts.
5. Remove front fender.
CAUTION:
Use care when removing front fender. The front fender urethane foam adheres the front fender to the body side outer. Carefully release the foam baffle or damage to the front fender may occur.
6. Release pawls and clips and remove emblem (if necessary).

FRONT FENDER

< REMOVAL AND INSTALLATION >

INSTALLATION

Installation is in the reverse order of removal.

CAUTION:

- After installation, apply touch-up paint if the paint peeled during procedure.
- After installing, perform fitting adjustment to the following components as necessary.
- Hood: Refer to [DLK-142, "HOOD ASSEMBLY : Adjustment"](#).
- Front door: Refer to [DLK-152, "DOOR ASSEMBLY : Adjustment"](#).

FRONT DOOR

< REMOVAL AND INSTALLATION >

FRONT DOOR

Exploded View

INFOID:000000013000160

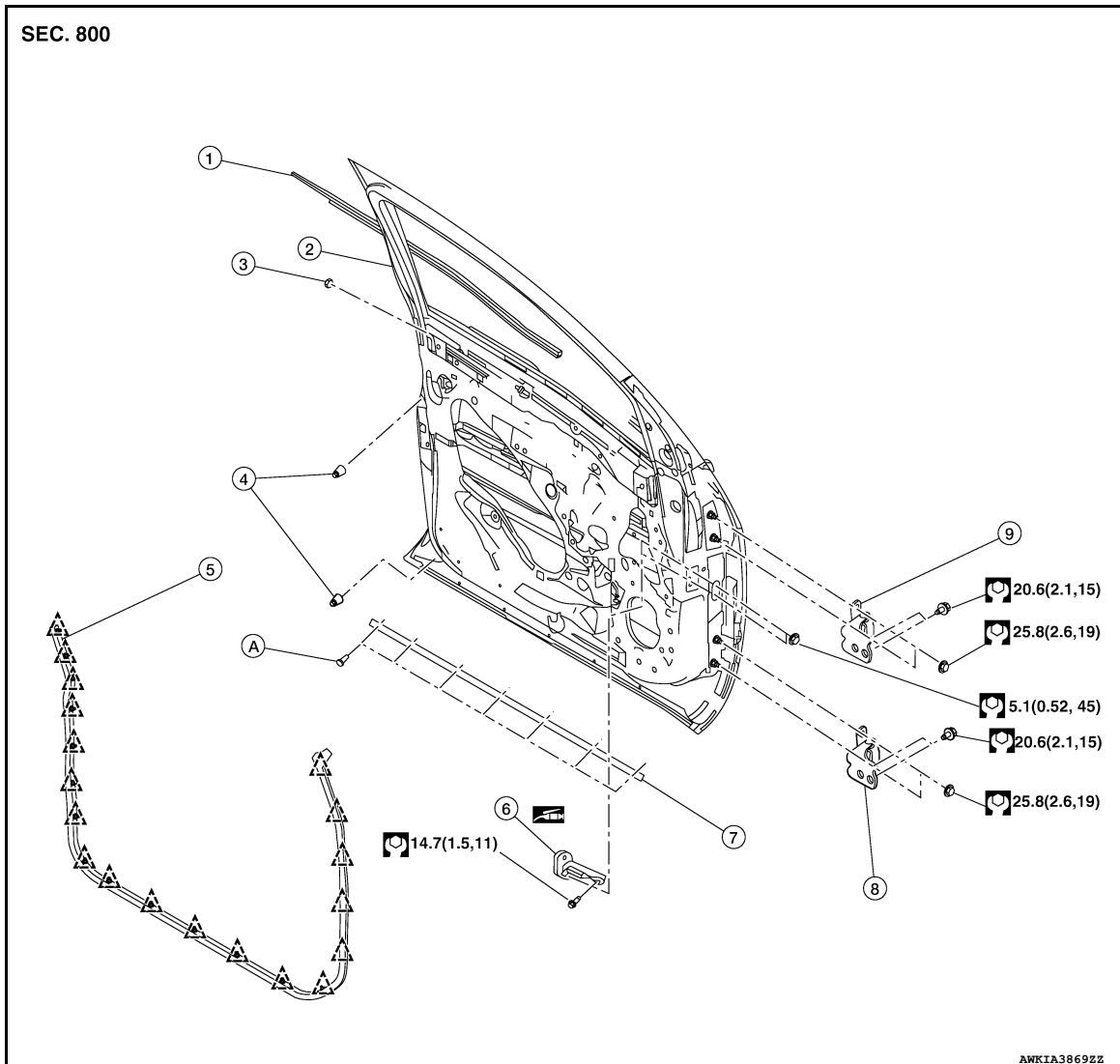

- | | | |
|----------------------|-----------------------|---------------------|
| 1. Door outside seal | 2. Door panel | 3. Grommet |
| 4. Bumper rubber | 5. Door weather-strip | 6. Check link |
| 7. Door parting seal | 8. Door lower hinge | 9. Door upper hinge |
| A. Clip | △ Clip | |

DOOR ASSEMBLY

DOOR ASSEMBLY : Removal and Installation

INFOID:000000013000161

CAUTION:

- Use two people when removing or installing the front door due to its heavy weight.
- When removing and installing front door assembly, support front door with a suitable tool.

REMOVAL

1. Remove dash side finisher. Refer to [INT-22. "DASH SIDE FINISHER : Removal and Installation"](#).
2. Disconnect front door harness connector.

FRONT DOOR

< REMOVAL AND INSTALLATION >

3. Remove front door harness grommet (1) as shown, and then pull out the harness from the body side outer (2).

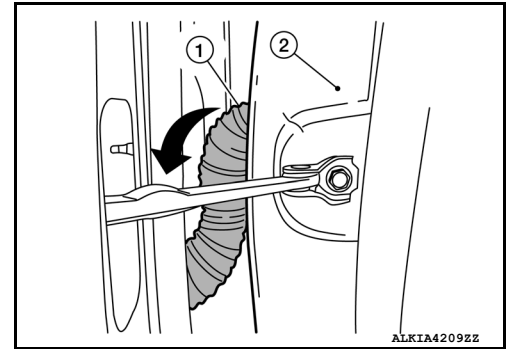

4. Remove door check link bolt (A) from the body side (1).

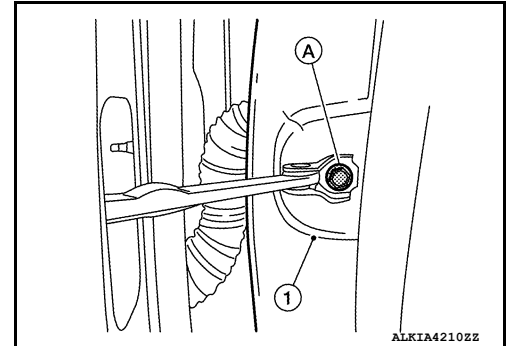

5. Remove front door hinge nuts then door.

INSTALLATION

Installation is in the reverse order of removal.

CAUTION:

- Apply anticorrosive agent where necessary.
- After installation, check front door open/close and lock/unlock operation.
- After installation, perform the front door adjustment procedure. Refer to [DLK-152, "DOOR ASSEMBLY : Adjustment"](#).
- Perform camera image calibration (if equipped with around view monitor). Refer to [AV-331, "Description"](#).

DOOR ASSEMBLY : Adjustment

INFOID:000000013000163

Adjustment

FRONT DOOR

< REMOVAL AND INSTALLATION >

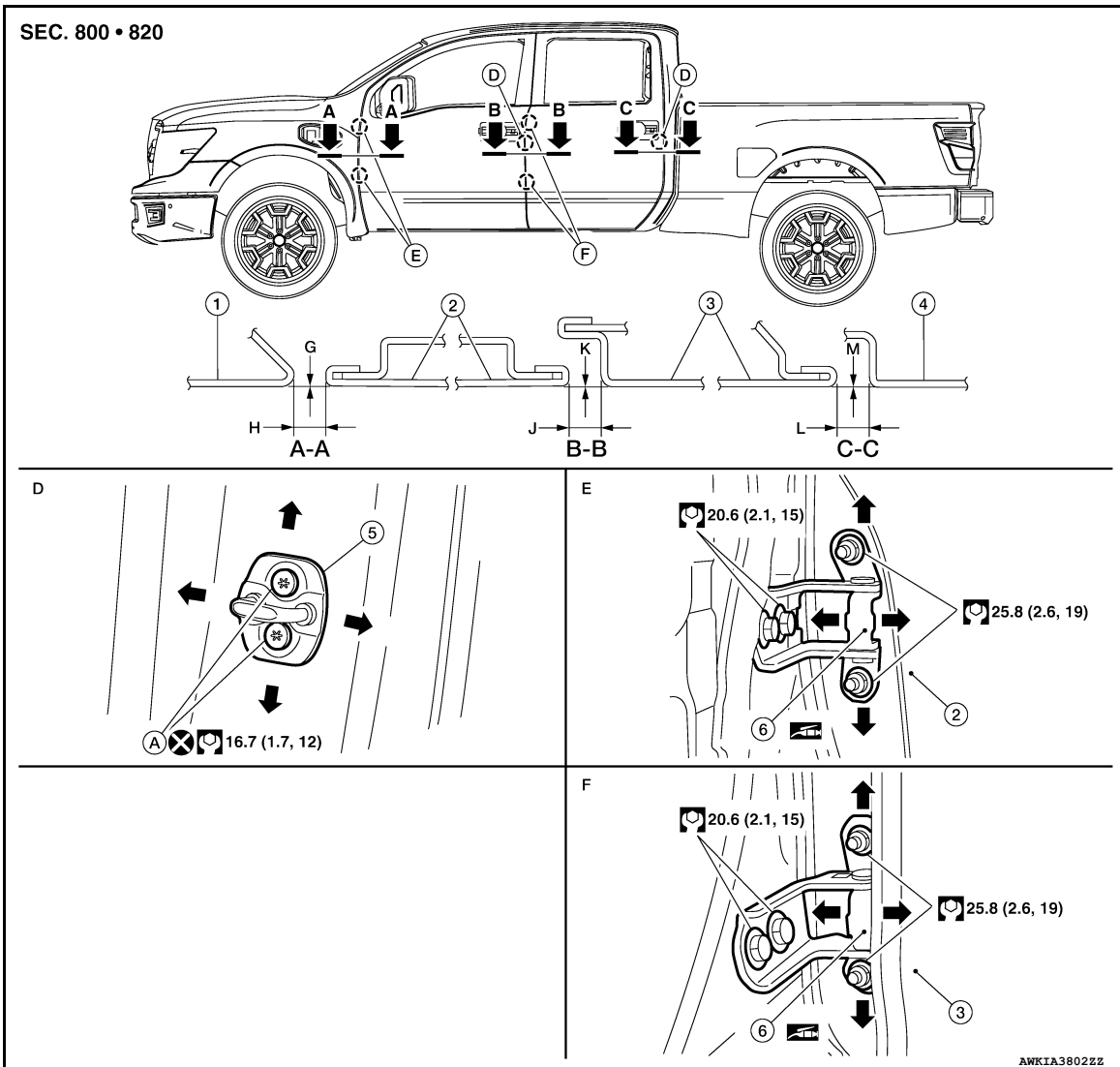

- 1. Front fender
- 2. Front door panel
- 3. Rear door panel
- 4. Body side outer
- 5. Door striker
- 6. Door hinge
- A. Door striker bolt

Check the clearance and surface height between front door and each part by visual inspection and tactile feel. If clearance and the surface height are out of specification, adjust them according to the adjustment procedure.

Unit: mm [in]

Portion		Standard		
Front fender panel – Front door panel	A-A	H	Clearance	4.5 ± 1.0 (0.18 ± 0.04)
		I	Surface height	0.1 ± 1.0 (0.00 ± 0.04)
Front door panel – Rear door panel	B-B	J	Clearance	4.5 ± 1.0 (0.18 ± 0.04)
		K	Surface height	0.1 ± 1.0 (0.00 ± 0.04)
Rear door panel – Body side outer	C-C	L	Clearance	4.5 ± 1.0 (0.18 ± 0.04)
		M	Surface height	0.1 ± 1.0 (0.00 ± 0.04)

1. Remove front fender. Refer to [DLK-149, "Removal and Installation"](#).

FRONT DOOR

< REMOVAL AND INSTALLATION >

2. Loosen door hinge nuts (A).

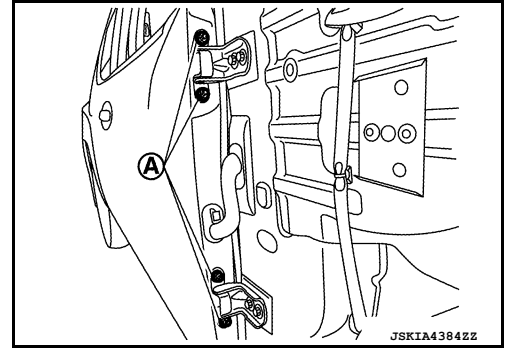

3. Adjust surface height of front door according to specifications provided.
4. Temporarily tighten door hinge nuts on door side.
5. Loosen door hinge bolts (A).

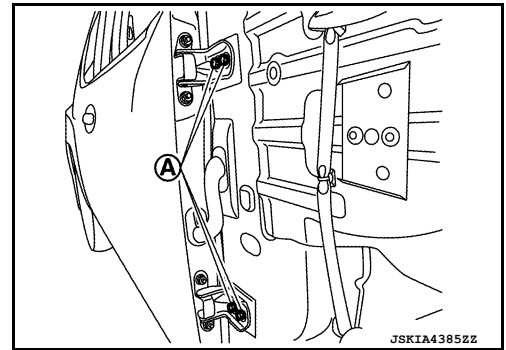

6. Raise front door at rear end to adjust clearance of front door according to specifications provided.
7. After adjustment, tighten bolts and nuts to specified torque.
CAUTION:
 - Check door hinge rotating point for poor lubrication. If necessary, apply a suitable multi-purpose grease.
 - After adjusting, apply touch-up paint if the paint peeled during procedure.
8. Install front fender. Refer to [DLK-149. "Removal and Installation"](#).

DOOR HINGE

DOOR HINGE : Removal and Installation

INFOID:000000013000166

REMOVAL

1. Remove front door. Refer to [DLK-151, "DOOR ASSEMBLY : Removal and Installation"](#).
2. Remove front door hinge bolts from body side and front door hinge.

INSTALLATION

Installation is in the reverse order of removal.

CAUTION:

- Apply anticorrosive agent to hinge mating surface.
- After installation, check front door open/close and lock/unlock operation.
- Check door hinge rotating point for poor lubrication. If necessary, apply a suitable multi-purpose grease.
- After installation, perform front door adjustment procedure. Refer to [DLK-152, "DOOR ASSEMBLY : Adjustment"](#).

DOOR CHECK LINK

DOOR CHECK LINK : Removal and Installation

INFOID:000000013000167

REMOVAL

1. Fully close the front door window glass.

FRONT DOOR

< REMOVAL AND INSTALLATION >

- Remove front door speaker. Refer to [AV-281, "Removal and Installation"](#) (NAVIGATION WITH AMPLIFIER) , [AV-281, "Removal and Installation"](#) (NAVIGATION WITHOUT AMPLIFIER), or [AV-68, "Removal and Installation"](#) (DISPLAY AUDIO).
- Remove door check link bolt (A) from body side (1).

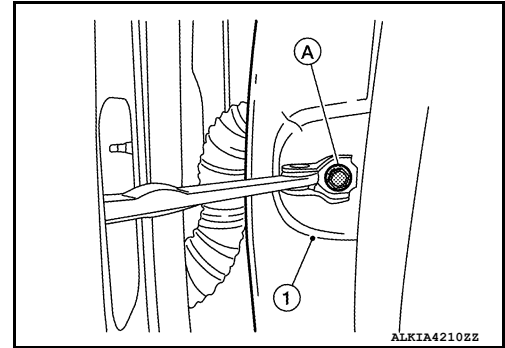

- Remove door check link nuts (A) from door side (1).

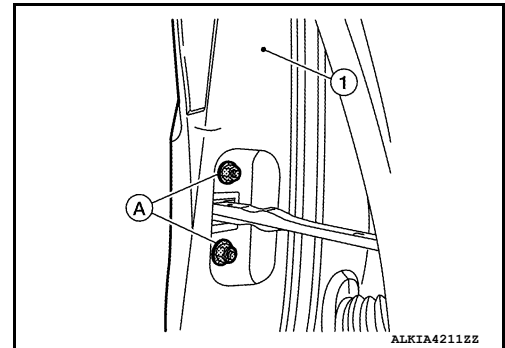

- Remove door check link through hole in door panel.

INSTALLATION

Installation is in the reverse order of removal.

CAUTION:

- After installation, check front door open/close and lock/unlock operation.
- Check door check link for poor lubrication. If necessary, apply a suitable multi-purpose grease.

DOOR WEATHER-STRIP

DOOR WEATHER-STRIP : Removal and Installation

INFOID:000000013000168

REMOVAL

- Disengage clips of front door weather-strip using a suitable tool (A).

 : Clip

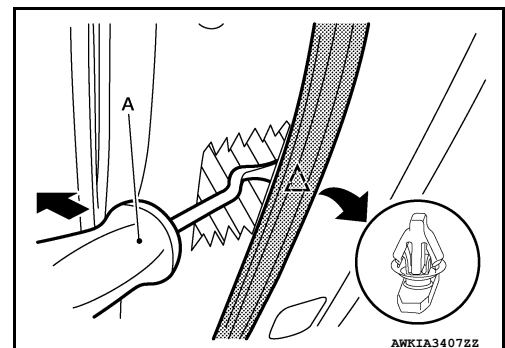

CAUTION:

Do not damage front door panel.

- Remove front door weather-strip from front door panel.

INSTALLATION

Installation is in the reverse order of removal.

A
B
C
D
E
F
G
H
I
J
L
M
N
O
P

DLK

REAR DOOR

< REMOVAL AND INSTALLATION >

REAR DOOR

Exploded View

INFOID:000000013000169

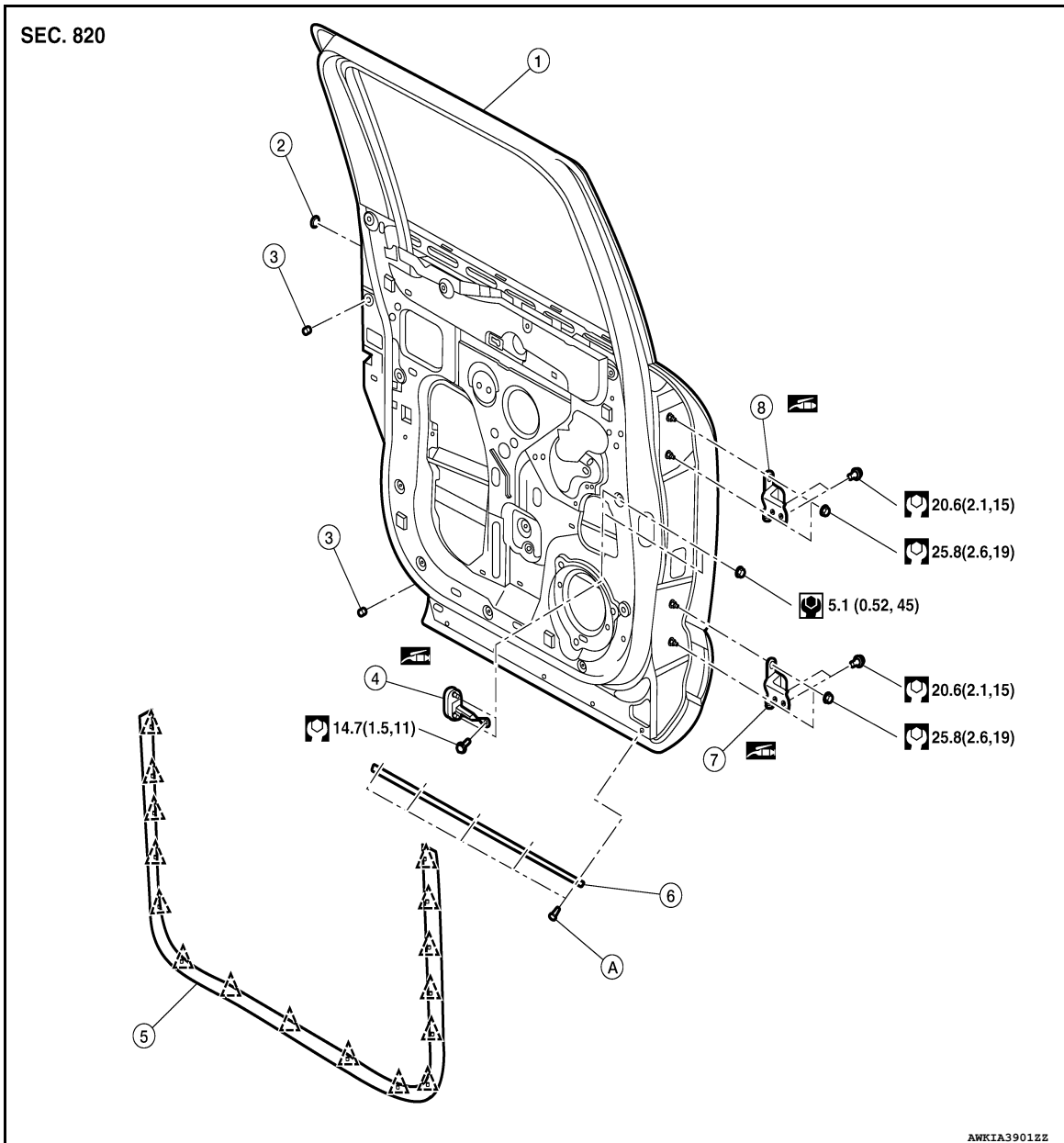

- | | | |
|---------------------|-----------------------|----------------------|
| 1. Rear door panel | 2. Grommet | 3. Bumper rubber |
| 4. Door check link | 5. Door weather-strip | 6. Door parting seal |
| 7. Door lower hinge | 8. Door upper hinge | △ Clip |

DOOR ASSEMBLY

DOOR ASSEMBLY : Removal and Installation

INFOID:000000013000170

CAUTION:

- Use two people when removing or installing rear door due to its heavy weight.
- When removing and installing rear door assembly, support rear door using a suitable tool.

REMOVAL

REAR DOOR

< REMOVAL AND INSTALLATION >

1. Remove center pillar lower finisher. Refer to [INT-23. "CENTER PILLAR LOWER FINISHER : Removal and Installation"](#).
2. Disconnect rear door harness connector.
3. Remove rear door harness grommet (1), then pull out the harness from body side outer (2).

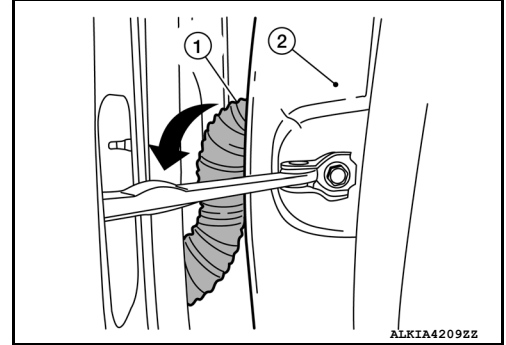

4. Remove rear door check link bolt (A) from body side (1).

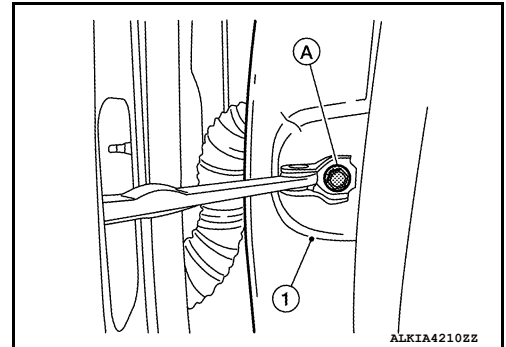

5. Remove rear door hinge nuts from door side, and then remove rear door assembly.

INSTALLATION

Installation is in the reverse order of removal.

CAUTION:

- Apply anticorrosive agent where necessary.
- After installation, check rear door open/close and lock/unlock operation.
- After installation, perform rear door adjustment procedure. Refer to [DLK-157. "DOOR ASSEMBLY : Adjustment"](#).

DOOR ASSEMBLY : Adjustment

INFOID:000000013000172

A
B
C
D
E
F
G
H
I
J
DLK
L
M
N
O
P

REAR DOOR

< REMOVAL AND INSTALLATION >

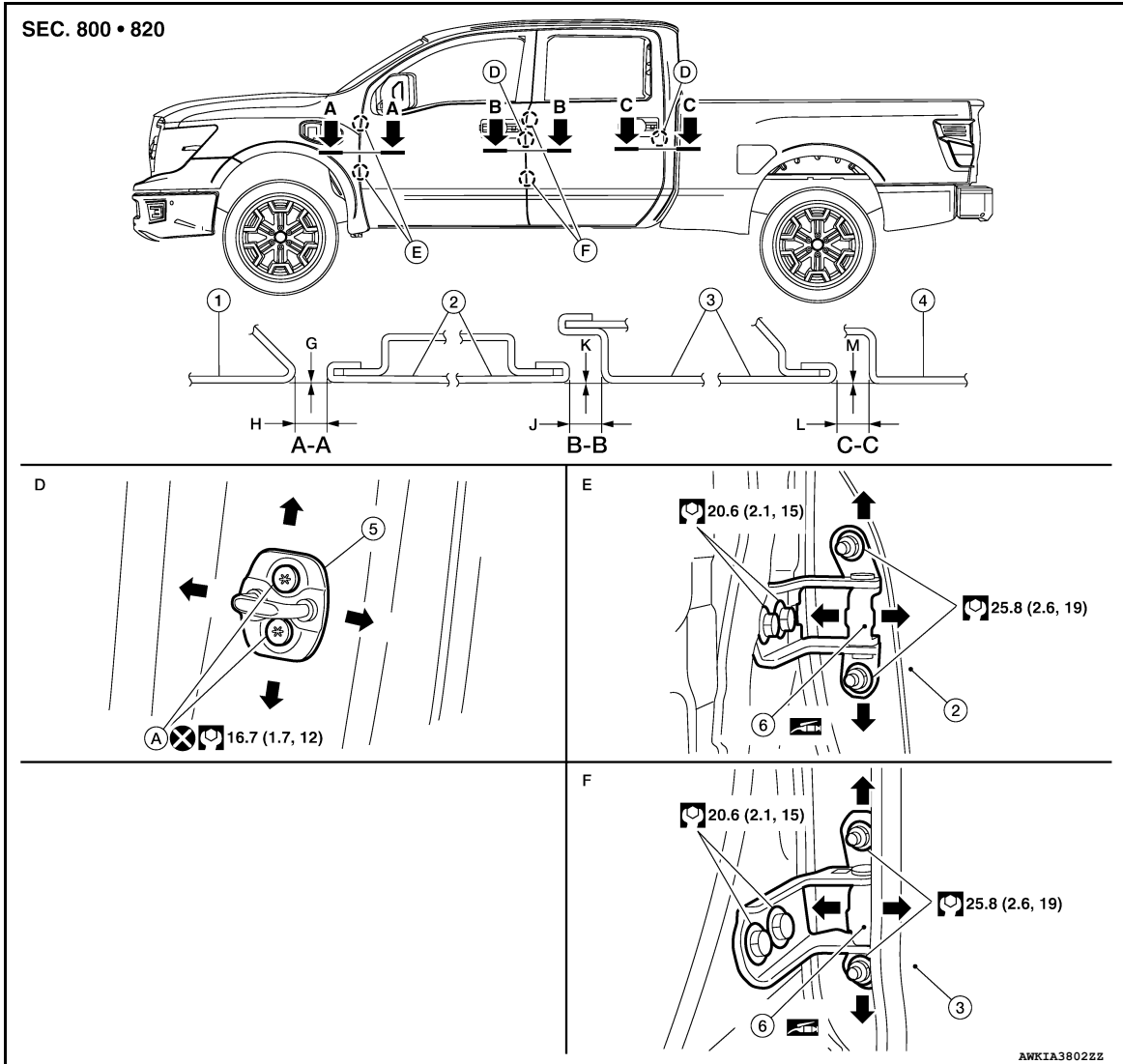

- 1. Front fender
- 2. Front door panel
- 3. Rear door panel
- 4. Body side outer
- 5. Door striker
- 6. Door hinge
- A. Door striker bolt

Check clearance and surface height between rear door and each part by visual inspection and tactile feel. If clearance and surface height are out of specification, adjust them according to adjustment procedures.

Unit: mm [in]

Portion		Standard		
Front fender panel – Front door panel	A-A	H	Clearance	4.5 ± 1.0 (0.18 ± 0.04)
		I	Surface height	0.1 ± 1.0 (0.00 ± 0.04)
Front door panel – Rear door panel	B-B	J	Clearance	4.5 ± 1.0 (0.18 ± 0.04)
		K	Surface height	0.1 ± 1.0 (0.00 ± 0.04)
Rear door panel – Body side outer	C-C	L	Clearance	4.5 ± 1.0 (0.18 ± 0.04)
		M	Surface height	0.1 ± 1.0 (0.00 ± 0.04)

1. Remove center pillar lower finisher. Refer to [INT-23, "CENTER PILLAR LOWER FINISHER : Removal and Installation"](#).
2. Loosen rear door hinge nuts on door side.
3. Adjust surface height of rear door according to specifications provided.
4. Temporarily tighten rear door hinge nuts on door side.

REAR DOOR

< REMOVAL AND INSTALLATION >

5. Loosen rear door hinge nuts and bolts on body side.
6. Raise rear door at rear end to adjust clearance of rear door according to specifications provided.
7. After adjustment, tighten bolts and nuts to specified torque.

CAUTION:

- Check rear door hinge rotating point for poor lubrication. If necessary, apply a suitable multi-purpose grease.
- After adjusting, apply touch-up paint if the paint peeled during procedure.

8. Install center pillar lower finisher. Refer to [INT-23, "CENTER PILLAR LOWER FINISHER : Removal and Installation"](#).

DOOR HINGE

DOOR HINGE : Removal and Installation

INFOID:000000013000175

REMOVAL

1. Remove rear door. Refer to [DLK-156, "DOOR ASSEMBLY : Removal and Installation"](#).
2. Remove door hinge nuts from body side, then remove door hinge.

INSTALLATION

Installation is in the reverse order of removal.

CAUTION:

- Apply anticorrosive agent onto hinge mating surface.
- After installation, check rear door open/close and lock/unlock operation.
- After installation, perform rear door adjustment procedure. Refer to [DLK-157, "DOOR ASSEMBLY : Adjustment"](#).

DOOR CHECK LINK

DOOR CHECK LINK : Removal and Installation

INFOID:000000013000176

REMOVAL

1. Fully close the rear door window glass.
2. Remove rear door speaker. Refer to [AV-283, "Removal and Installation"](#) (NAVIGATION WITH AMPLIFIER) , [AV-161, "Removal and Installation"](#) (NAVIGATION WITHOUT AMPLIFIER), or [AV-69, "Removal and Installation"](#) (DISPLAY AUDIO).
3. Remove door check link bolt (A) from body side (1).

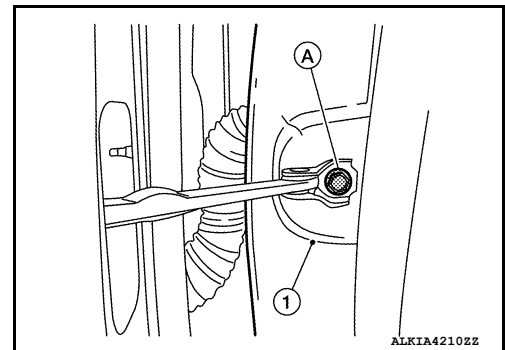

4. Remove door check link nuts (A) from door side (1).

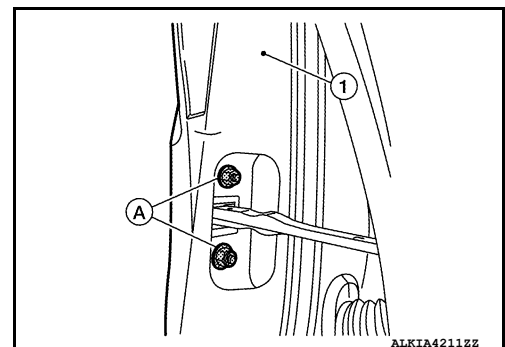

A
B
C
D
E
F
G
H
I
J
L
M
N
O
P

DLK

REAR DOOR

< REMOVAL AND INSTALLATION >

5. Remove door check link through hole in door panel.

INSTALLATION

Installation is in the reverse order of removal.

CAUTION:

After installation, check rear door open/close and lock/unlock operation.

DOOR WEATHER-STRIP

DOOR WEATHER-STRIP : Removal and Installation

INFOID:000000013000177

REMOVAL

1. Release clips on the reverse side of rear door weather-strip using a suitable tool (A).

CAUTION:

Do not damage rear door panel.

 : Clip

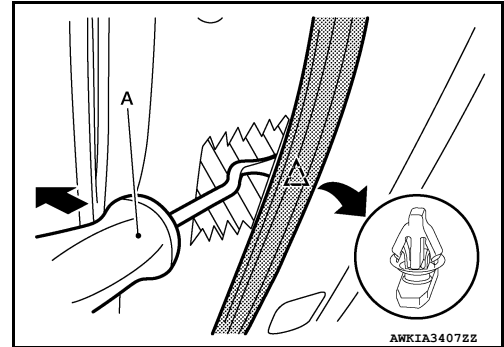

2. Remove rear door weather-strip from rear door panel.

INSTALLATION

Installation is in the reverse order of removal.

TAILGATE

< REMOVAL AND INSTALLATION >

1. Lower tailgate to access rear camera harness connector bracket [1 (if equipped)]. Release pawl on bracket, then pull out rear camera harness as shown.

 :Pawl

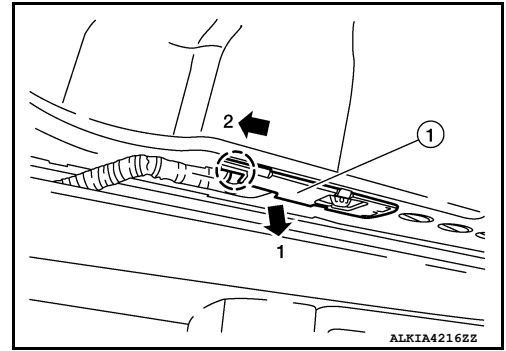

2. Disconnect rear view camera harness connector [A (if equipped)].

(1) :Tailgate harness cover

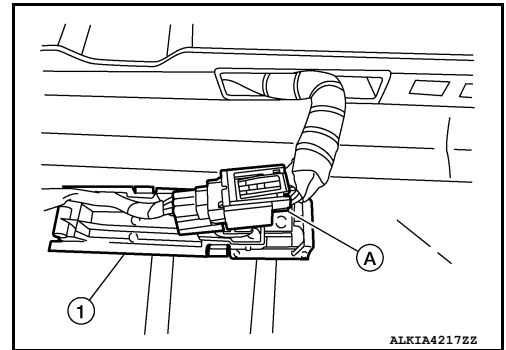

3. Release tailgate stay (LH/RH).

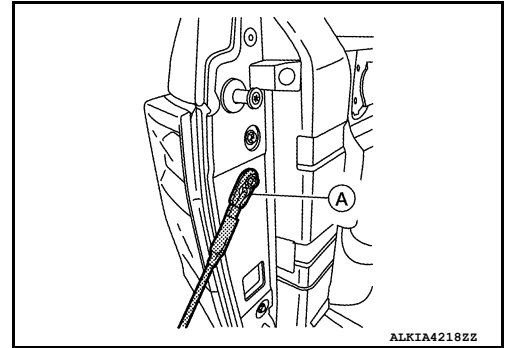

4. While holding tailgate at 45 degree angle, pull tailgate out from hinge [body side (LH)], then slide tailgate out of hinge [body side (RH)] and remove.

INSTALLATION

Installation is in the reverse order of removal.

CAUTION:

- Apply anticorrosive agent where necessary.
- After installation, check tailgate open/close and lock/unlock operation.
- Perform camera image calibration (if equipped with around view monitor). Refer to [AV-331, "Description"](#)

TAILGATE STRIKER

TAILGATE STRIKER : Removal and Installation

INFOID:000000013000181

REMOVAL

TAILGATE

< REMOVAL AND INSTALLATION >

Remove tailgate striker bolt (1).

NOTE:

LH shown, RH similar.

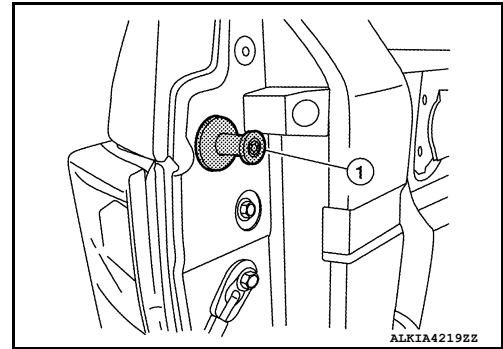

INSTALLATION

Installation is in the reverse order of removal.

CAUTION:

After installation, check tailgate open/close operation. If necessary, adjust tailgate striker. Refer to [DLK-178, "TAILGATE LOCK : Inspection"](#).

TAILGATE HINGE

TAILGATE HINGE : Removal and Installation

INFOID:000000013000182

REMOVAL

1. Remove tailgate assembly. Refer to [DLK-161, "TAILGATE ASSEMBLY : Removal and Installation"](#).
2. Remove tailgate stay. Refer to [DLK-164, "TAILGATE STAY : Removal and Installation"](#).
3. Remove bolts (A) and then remove tailgate hinge [body side (1)].

NOTE:

LH shown, RH similar.

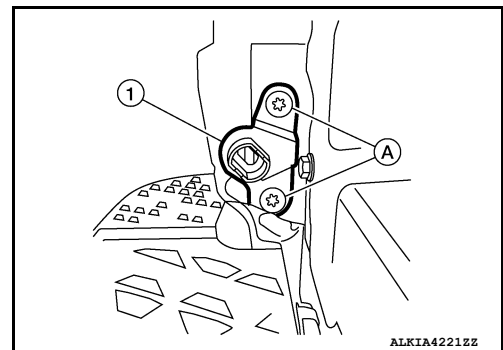

4. Remove bolts (A), then remove tailgate hinge (LH) tailgate side (1).

NOTE:

LH shown, RH similar.

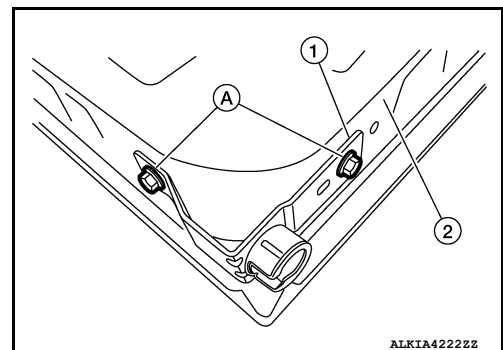

INSTALLATION

Installation is in the reverse order of removal.

CAUTION:

- Apply anticorrosive agent to hinge mating surface.
- After installation, check tailgate open/close and lock/unlock operation.
- Check tailgate hinge rotating point for poor lubrication. If necessary, apply a suitable multi-purpose grease.

TAILGATE STAY

A
B
C
D
E
F
G
H
I
J
DLK
L
M
N
O
P

TAILGATE

< REMOVAL AND INSTALLATION >

TAILGATE STAY : Removal and Installation

INFOID:000000013019537

REMOVAL

WARNING:

The gas stay is under high pressure. Remove the gas stay only with the tailgate fully closed. Injury may result if the gas stay is removed when the tailgate is open.

1. Remove the rear combination lamp assembly (RH). Refer to [EXL-302, "Removal and Installation"](#) (LED HEADLAMP), or [EXL-144, "Removal and Installation"](#) (HALOGEN HEADLAMP).
2. Using suitable tool (A) release metal clip (3) as shown.

- (1) : Hood stay
(2) : Stud ball

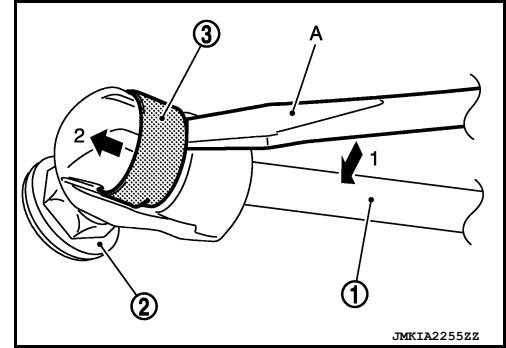

3. Separate tailgate stay from stud ball tailgate hinge [body side (RH)].
4. Separate tailgate stay from stud ball (body side) then remove tailgate stay.

INSTALLATION

Installation is in the reverse order of removal.

TAILGATE STAY : Disposal

INFOID:000000013019538

1. Fix tailgate stay (1) using a vise (C).
2. Using hacksaw (A) slowly make 2 holes in the tailgate stay, in numerical order as shown.

CAUTION:

- When cutting a hole on tailgate gas stay, always cover hacksaw with shop cloths (B) to avoid scattering metal fragments or oil.
- Wear eye protection (safety glasses).
- Wear gloves.

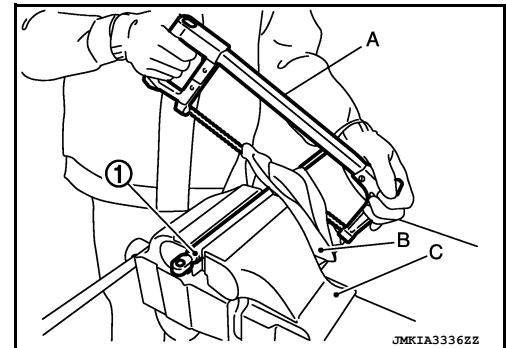

- A:** 20 mm. (0.8 in)
B: Cut at the groove.

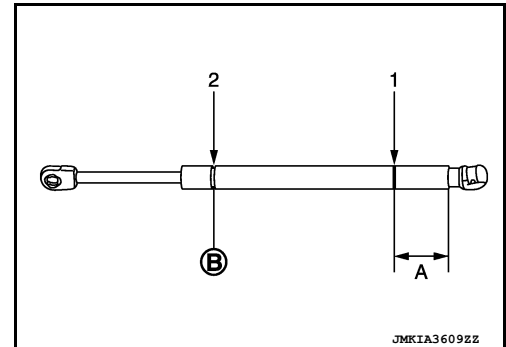

HOOD LOCK

< REMOVAL AND INSTALLATION >

HOOD LOCK

Exploded View

INFOID:000000013000183

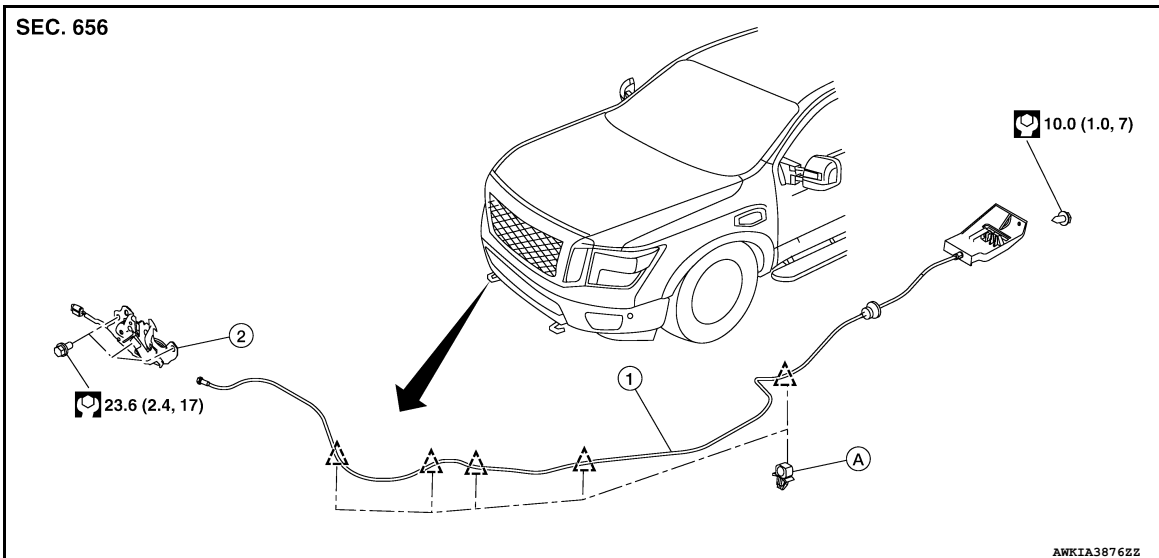

1. Hood lock release cable

2. Hood lock

 Clip

A. Clip

HOOD LOCK

HOOD LOCK : Removal and Installation

INFOID:000000013000184

REMOVAL

1. Remove front grille. Refer to [EXT-24. "Removal and Installation"](#).
2. Remove bolts (A).
3. Disconnect harness connector (B) from hood lock (1).

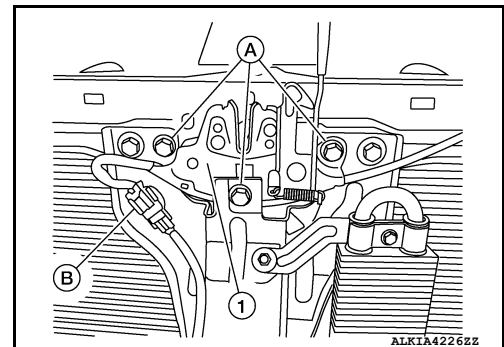

4. Disconnect hood lock control cable (2) from hood lock (1) in the sequence shown.

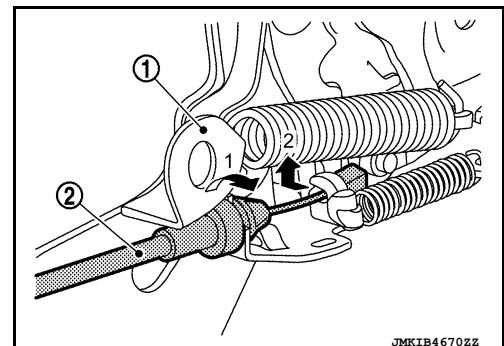

INSTALLATION

A
B
C
D
E
F
G
H
I
J
DLK
L
M
N
O
P

HOOD LOCK

< REMOVAL AND INSTALLATION >

Installation is in the reverse order of removal.

CAUTION:

- Check that hood lock release cable and secondary latch cable are properly engaged with hood lock.
- After installation, perform hood fitting adjustment. Refer to [DLK-142, "HOOD ASSEMBLY : Adjustment"](#).
- After installation, perform hood lock control inspection. Refer to [DLK-166, "HOOD LOCK : Inspection"](#).

HOOD LOCK : Inspection

INFOID:000000013019650

NOTE:

If hood lock release cable is bent or deformed, replace it.

1. Check that secondary latch is properly engaged with secondary striker with hood's own weight.
2. While operating hood lock release handle, carefully check that front end of hood is raised by approximately 20.0 mm (0.79 in). Also check that hood lock release handle returns to original position.
3. Check that hood lock release handle operates at 49 N (5.0 kg-m, 11.0 ft-lb) or below.
4. Install so that static closing force of hood is 315-490 N (32.1-50.0 kg-m, 70.8-110.2 ft-lb).

NOTE:

- Do not exert vertical force on right side and left side of hood lock.
 - Do not press simultaneously on both sides.
5. Check hood lock lubrication condition. If necessary, apply a suitable multi-purpose grease to hood lock.

HOOD LOCK RELEASE CABLE

HOOD LOCK RELEASE CABLE : Removal and Installation

INFOID:000000013000187

REMOVAL

1. Remove hood lock. Refer to [DLK-165, "HOOD LOCK : Removal and Installation"](#).
2. Release hood lock release cable clips using a suitable tool.
3. Remove instrument lower panel. Refer to [IP-22, "Removal and Installation"](#).
4. Remove hood lock release handle bolts.
5. Remove grommet on the lower dash, and pull the hood lock control cable toward the passenger compartment.

CAUTION:

While pulling, be careful not to damage (peel) outside of hood lock release cable.

INSTALLATION

Installation is in the reverse order of removal.

CAUTION:

- Be careful not to bend cable too much; keep radius of 100 mm (3.94 in) or more.
- Check that cable is not offset from positioning grommet, and apply sealant to grommet (at * mark) properly.

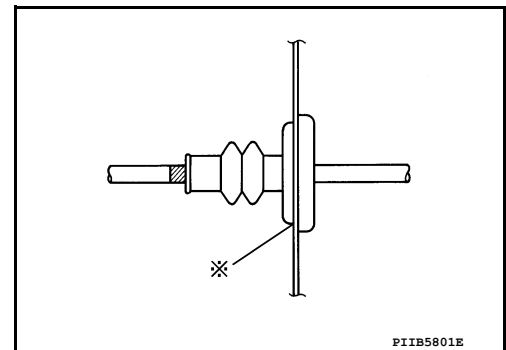

- Check that hood lock release cable is properly engaged with hood lock assembly.
- After installation, perform hood assembly adjustment procedure. Refer to [DLK-142, "HOOD ASSEMBLY : Adjustment"](#).
- After adjusting, perform hood lock inspection. Refer to [DLK-166, "HOOD LOCK : Inspection"](#).

FRONT DOOR LOCK

< REMOVAL AND INSTALLATION >

FRONT DOOR LOCK

Exploded View

INFOID:000000013000188

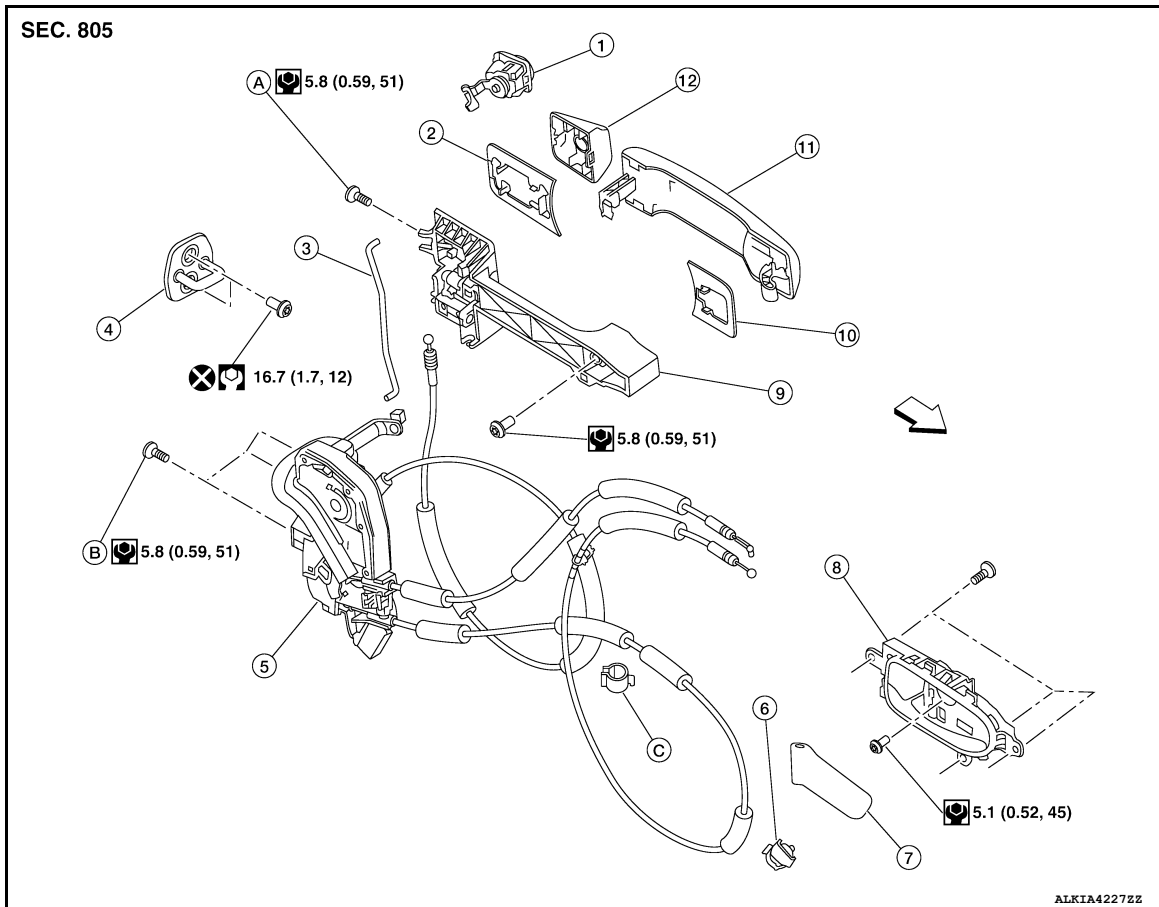

- | | | |
|----------------------------------|--------------------|-------------------------------|
| 1. Door lock cylinder | 2. Rear gasket | 3. Door key cylinder rod |
| 4. Striker | 5. Door lock | 6. Cable clip |
| 7. Inside door handle escutcheon | 8. Inside handle | 9. Outside handle bracket |
| 10. Front gasket | 11. Outside handle | 12. Outside handle escutcheon |
| A. Outside handle bracket bolt | B. Door lock bolt | C. Cable clip |
| Pawl | Front | |

DOOR LOCK

DOOR LOCK : Removal and Installation

INFOID:000000013000189

REMOVAL

1. Fully close the front door glass.
2. Remove front door finisher. Refer to [INT-14, "Removal and Installation"](#).
3. Partially remove front door vapor barrier (rear side).

FRONT DOOR LOCK

< REMOVAL AND INSTALLATION >

4. Separate door key cylinder rod [1 (LH only)] from door key cylinder assembly [2 (LH only)].

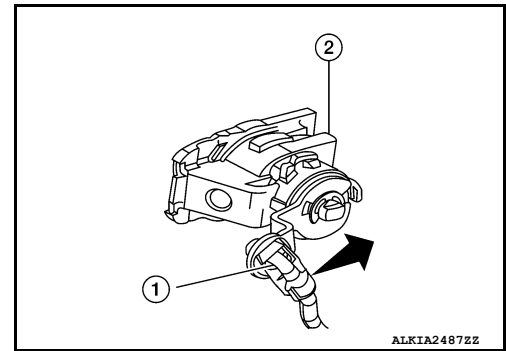

5. Disconnect the harness connector from door lock.
6. Disconnect outside handle cable (1) from outside handle bracket (2) in numerical order as shown.

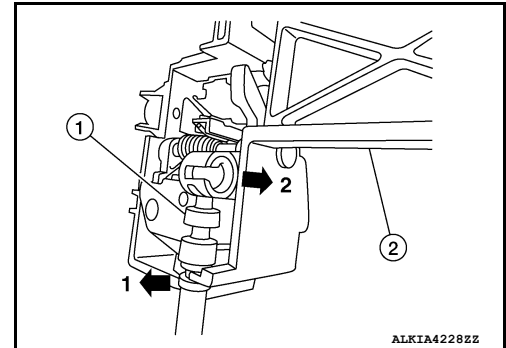

7. Release door lock assembly cable clips.
8. Remove front door lock bolts, then remove door lock.

CAUTION:

Do not reuse front door lock bolts.

INSTALLATION

Installation is in the reverse order of removal.

CAUTION:

- After installation, check that door lock cables are properly engaged to inside handle and outside handle bracket.
- When installing door key cylinder rod (LH only), be sure to rotate door key cylinder rod holder until a click is felt.
- After installation, check door open/close and lock/unlock operation.
- Check door lock assembly for poor lubrication. If necessary, apply a suitable multi-purpose grease.

INSIDE HANDLE

INSIDE HANDLE : Removal and Installation

INFOID:000000013000190

REMOVAL

1. Remove front door finisher. Refer to [INT-14. "Removal and Installation"](#).
2. Remove inside handle screws (A).
3. Release pawls and remove inside door handle.

 : Pawl

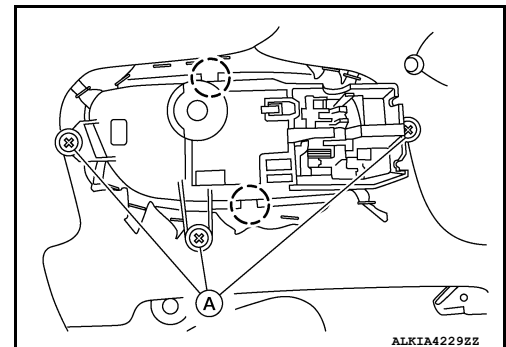

INSTALLATION

Installation is in the reverse order of removal.

FRONT DOOR LOCK

< REMOVAL AND INSTALLATION >

CAUTION:

- After installation, check that door lock cables are properly engaged to inside handle.
- After installation, check door open/close and lock/unlock operation.

OUTSIDE HANDLE

OUTSIDE HANDLE : Removal and Installation

INFOID:0000000013000191

REMOVAL

1. Fully close front door glass.
2. Remove front door finisher. Refer to [INT-14, "Removal and Installation"](#).
3. Partially remove front door vapor barrier (rear side).
4. Remove door side grommet, and loosen front door lock bolt (1).

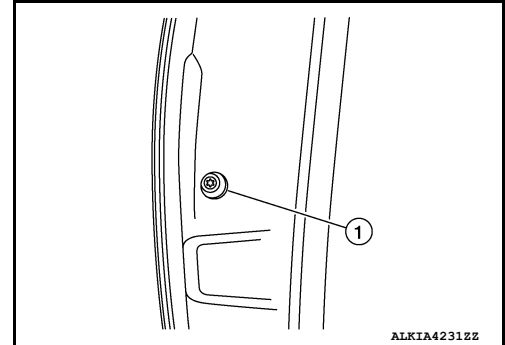

5. Separate door key cylinder rod [1 (LH only)] from door key cylinder assembly [2 (LH only)].

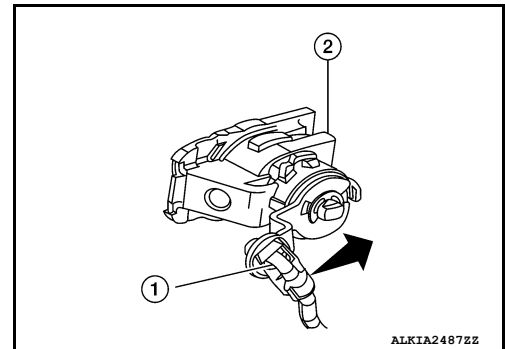

6. Remove door key cylinder assembly [1 (LH side)] or outside handle escutcheon (RH side).

(2) : Outside handle

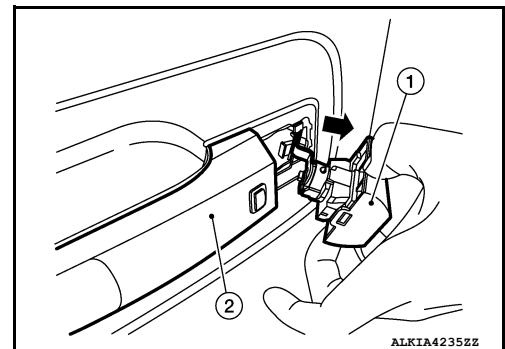

7. Disconnect the harness connectors from door handle (A), then disengage harness clips.

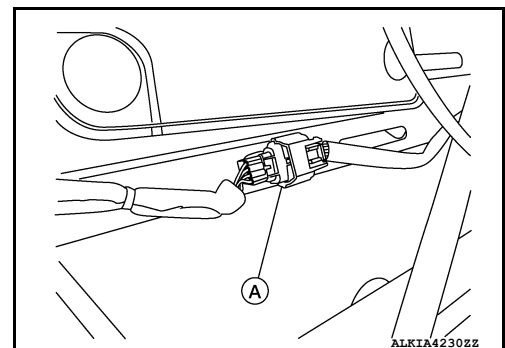

A
B
C
D
E
F
G
H
I
J
DLK
L
M
N
O
P

FRONT DOOR LOCK

< REMOVAL AND INSTALLATION >

8. While pulling outside handle (1), slide it toward rear of vehicle to remove outside handle.

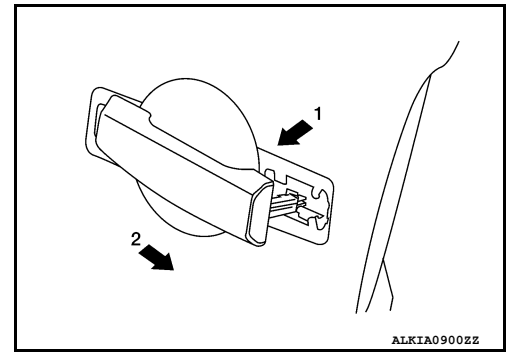

9. Remove front gasket (1) and rear gasket [2 (if necessary)].

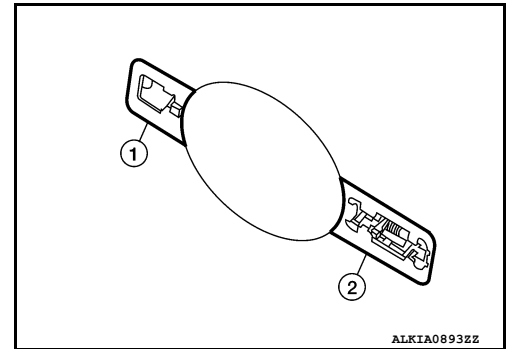

10. Loosen screw [A (if necessary)].

(1) : Outside handle bracket

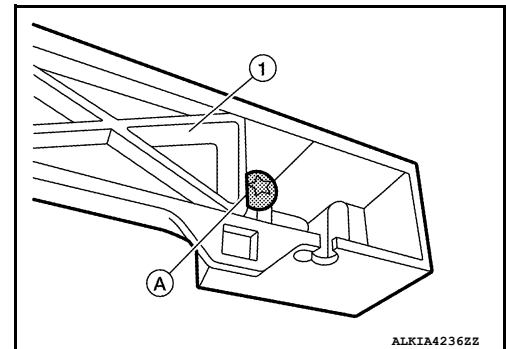

11. Remove handle bracket as shown (if necessary).

⇐ : Front

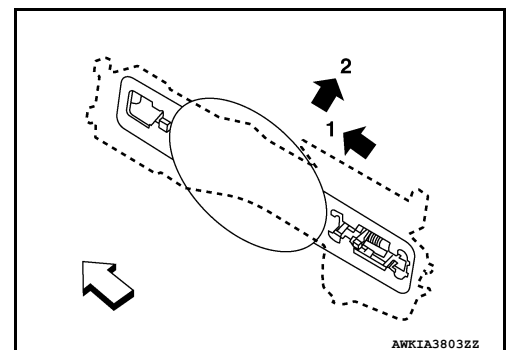

12. Disconnect outside handle cable (1) from outside handle bracket (2) in numerical order as shown (if necessary).

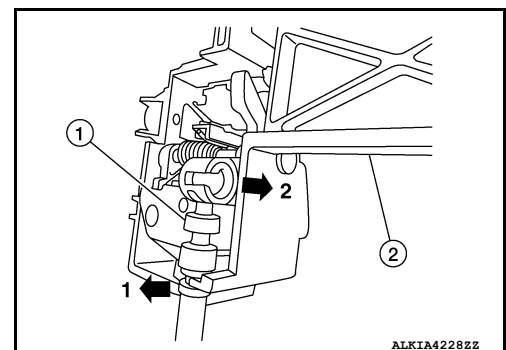

FRONT DOOR LOCK

< REMOVAL AND INSTALLATION >

INSTALLATION

Installation is in the reverse order of removal.

CAUTION:

- When installing door key cylinder rod, be sure to rotate door key cylinder rod holder until a click is felt.
- After installation, check that door lock cable is properly engaged to outside handle bracket.
- After installation, check door open/close and lock/unlock operation.

DOOR STRIKER

DOOR STRIKER : Removal and Installation

INFOID:000000013065456

REMOVAL

Remove bolts and front door striker.

INSTALLATION

Installation is in the reverse order of removal.

CAUTION:

- Do not reuse front door striker bolts.
- After installation, check front door open/close operation. If necessary, adjust front door striker. Refer to [DLK-152, "DOOR ASSEMBLY : Adjustment"](#).

DOOR STRIKER : Adjustment

INFOID:000000013065457

DOOR STRIKER ADJUSTMENT

1. Loosen door striker bolts.
2. Adjust door striker so that it becomes parallel with front door lock insertion direction.

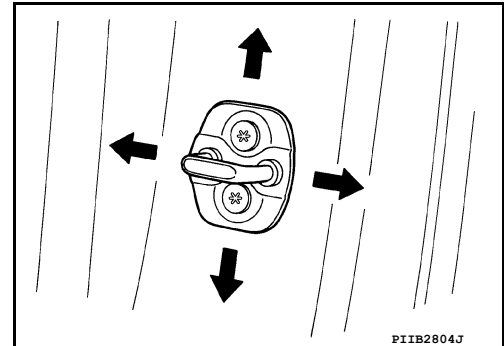

A
B
C
D
E
F
G
H
I
J
DLK
L
M
N
O
P

REAR DOOR LOCK

< REMOVAL AND INSTALLATION >

REAR DOOR LOCK

Exploded View

INFOID:000000013000192

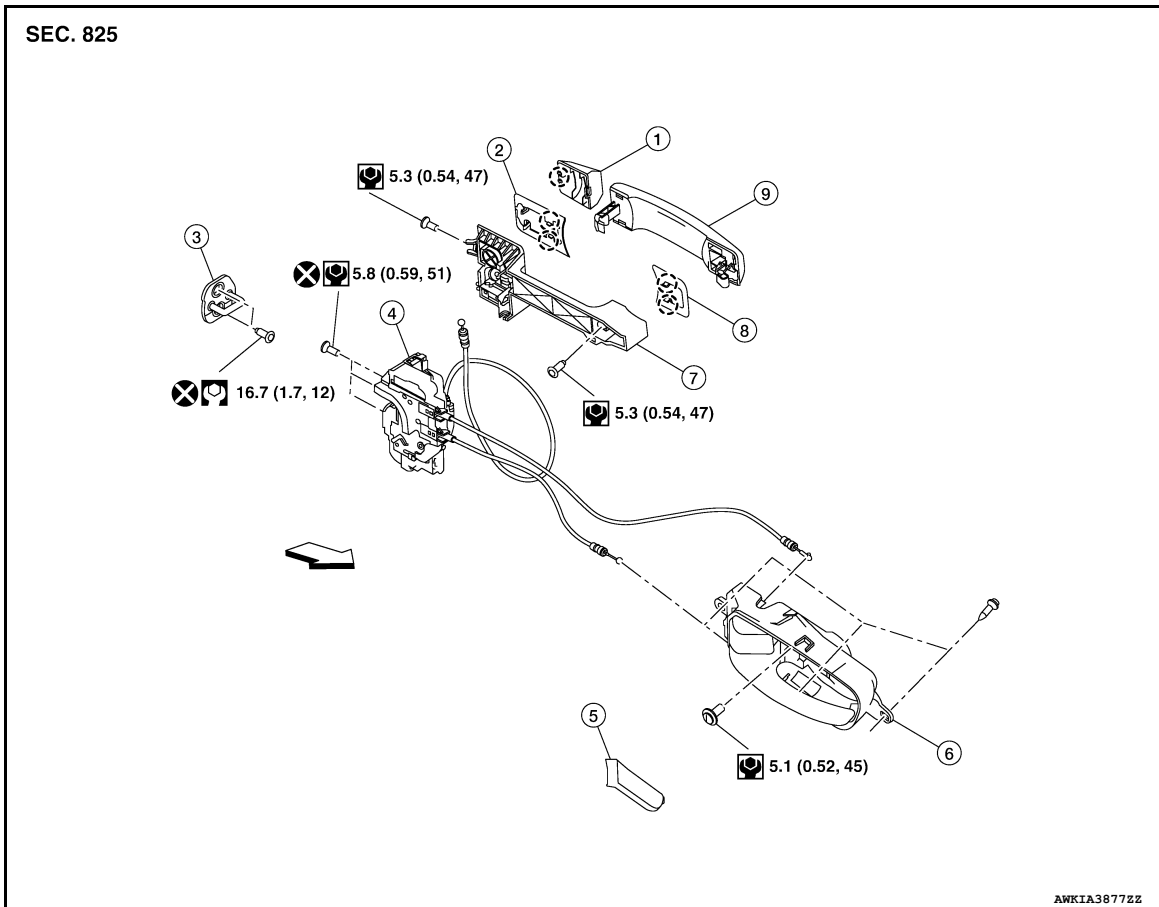

- | | | |
|------------------------------|----------------------------------|-------------------|
| 1. Outside handle escutcheon | 2. Rear gasket | 3. Striker |
| 4. Door lock | 5. Inside door handle escutcheon | 6. Inside handle |
| 7. Outside handle bracket | 8. Front gasket | 9. Outside handle |
| ⊗ Pawl | ⇨ Front | |

DOOR LOCK

DOOR LOCK : Removal and Installation

INFOID:000000013000193

REMOVAL

1. Fully close the rear door glass.
2. Remove rear door finisher. Refer to [INT-17, "Removal and Installation"](#).
3. Partially remove front door vapor barrier (rear side).
4. Disconnect harness connector from the door lock.

REAR DOOR LOCK

< REMOVAL AND INSTALLATION >

5. Disconnect outside handle cable (1) from outside handle bracket (2) as shown.

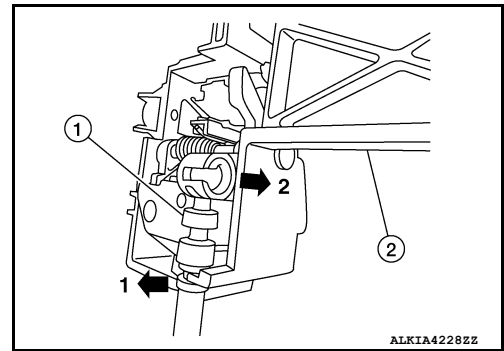

6. Remove rear door lock bolts, then remove door lock.

CAUTION:

Do not reuse rear door lock bolts.

INSTALLATION

Installation is in the reverse order of removal.

CAUTION:

- After installation, check that door lock cables are properly engaged to inside handle and outside handle.
- After installation, check door open/close and lock/unlock operation.

INSIDE HANDLE

INSIDE HANDLE : Removal and Installation

INFOID:000000013000194

REMOVAL

1. Remove rear door finisher. Refer to [INT-17, "Removal and Installation"](#).
2. Remove inside handle screws (A).
3. Release pawls and remove inside door handle.

 : Pawl

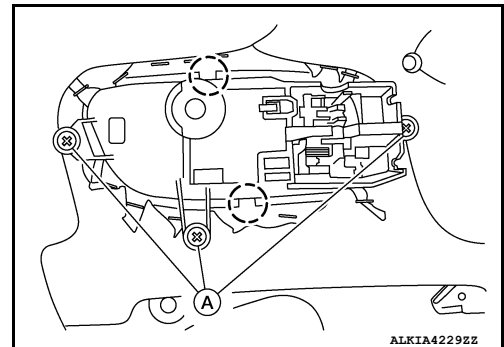

INSTALLATION

Installation is in the reverse order of removal.

CAUTION:

- After installation, check that door lock cables are properly engaged to inside handle.
- After installation, check door open/close and lock/unlock operation.

OUTSIDE HANDLE

OUTSIDE HANDLE : Removal and Installation

INFOID:000000013000195

REMOVAL

1. Fully close rear door glass.
2. Remove rear door finisher. Refer to [INT-17, "Removal and Installation"](#).
3. Partially remove front door vapor barrier (rear side).

A
B
C
D
E
F
G
H
I
J
DLK
L
M
N
O
P

REAR DOOR LOCK

< REMOVAL AND INSTALLATION >

4. Remove door side grommet, and loosen door lock bolt (1).

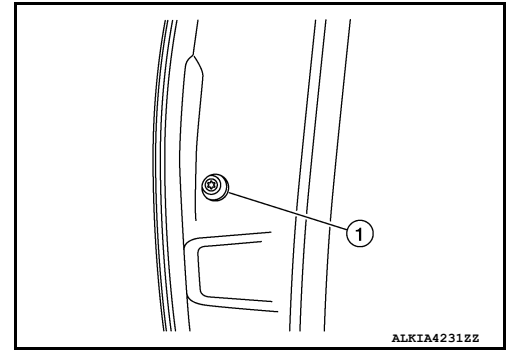

5. Remove outside handle escutcheon.

6. While pulling outside handle (1), slide it toward rear of vehicle to remove outside handle.

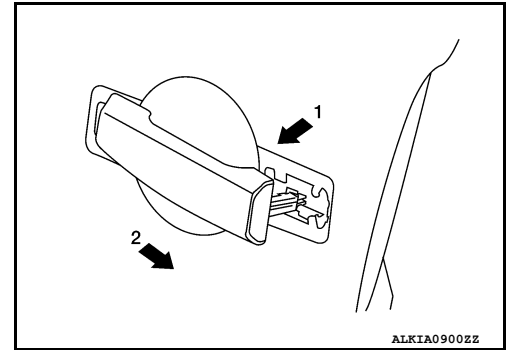

7. Remove front gasket (1) and rear gasket [2 (if necessary)].

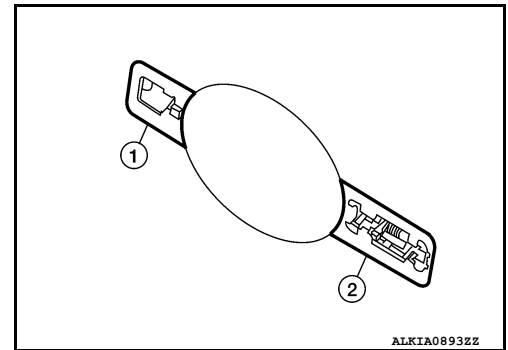

8. Loosen screw [A (if necessary)].

(1) : Outside handle bracket

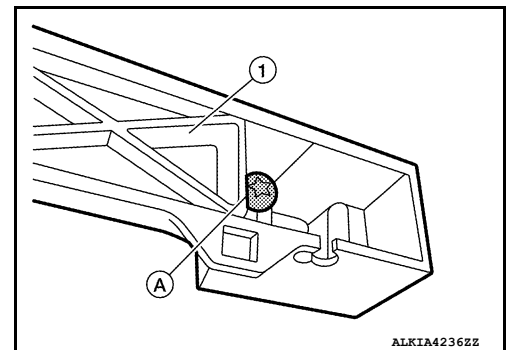

REAR DOOR LOCK

< REMOVAL AND INSTALLATION >

9. Remove outside handle bracket as shown (if necessary).

↶ : Front

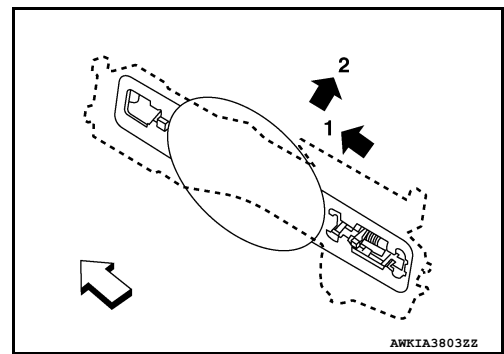

10. Disconnect outside handle cable (1) from outside handle bracket (2) in numerical order as shown (if necessary).

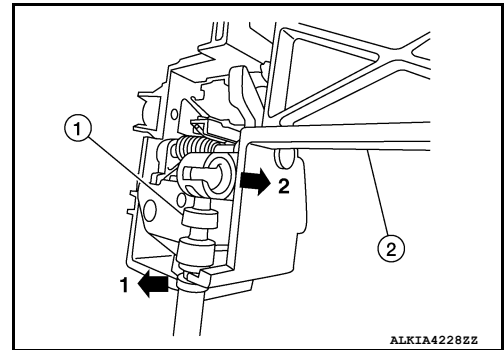

INSTALLATION

Installation is in the reverse order of removal.

CAUTION:

- After installation, check that door lock cable is properly engaged to outside handle bracket.
- After installation, check door open/close and lock/unlock operation.

DOOR STRIKER

DOOR STRIKER : Removal and Installation

INFOID:0000000013000173

REMOVAL

Remove bolts and rear door striker.

INSTALLATION

Installation is in the reverse order of removal.

CAUTION:

- Do not reuse rear door striker bolts.
- After installation, check rear door open/close operation. If necessary, adjust door striker. Refer to [DLK-175, "DOOR STRIKER : Adjustment"](#).

DOOR STRIKER : Adjustment

INFOID:0000000013000174

DOOR STRIKER ADJUSTMENT

1. Loosen door striker bolts.
2. Adjust door striker so that it becomes parallel with rear door lock insertion direction.

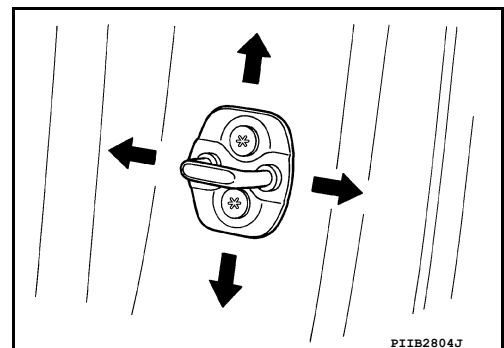

A
B
C
D
E
F
G
H
I
J
L
M
N
O
P

DLK

REAR DOOR LOCK

< REMOVAL AND INSTALLATION >

3. After adjustment, tighten bolts to specified torque.

TAILGATE LOCK

< REMOVAL AND INSTALLATION >

TAILGATE LOCK

Exploded View

INFOID:000000013000196

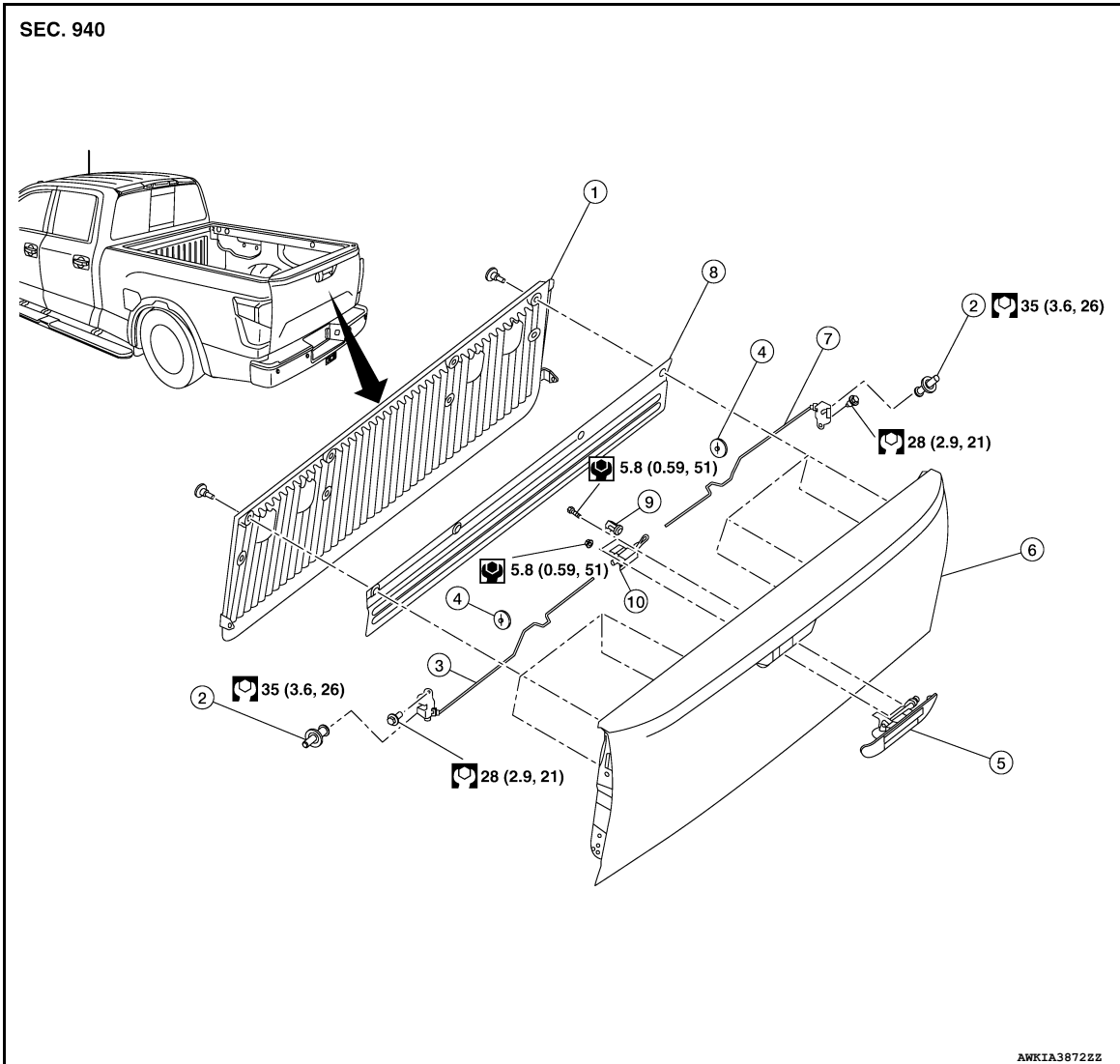

- | | | |
|-------------------------------|-----------------------------|------------------------------|
| 1. Tailgate protector | 2. Tailgate striker (LH/RH) | 3. Lock rod (LH) |
| 4. Lock rod protector (LH/RH) | 5. Tailgate handle | 6. Tailgate panel |
| 7. Lock rod (RH) | 8. Tailgate cover plate | 9. Rear camera (if equipped) |
| 10. Tailgate control assembly | | |

TAILGATE LOCK

TAILGATE LOCK : Removal and Installation

INFOID:000000013000197

REMOVAL

1. Remove tailgate finisher. Refer to [EXT-46. "Removal and Installation"](#).

TAILGATE LOCK

< REMOVAL AND INSTALLATION >

2. Release pawls then disengage tailgate lock connecting rods (2) (LH/RH) from tailgate control (A) and remove tailgate control.

(1) :Tailgate control retainer

○ :Pawl

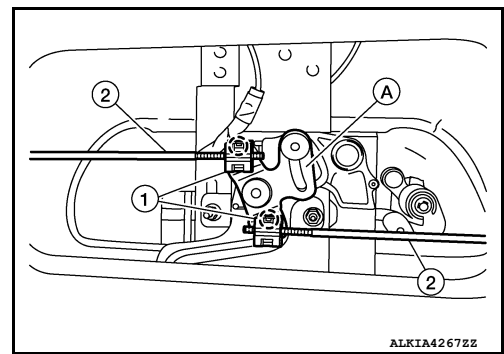

3. Remove tailgate lock bolts (A) (LH/RH) then remove tailgate lock (1) with rod as shown.

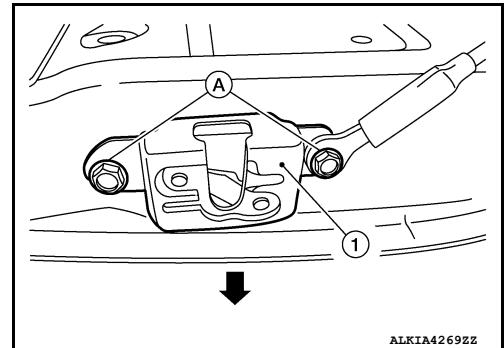

4. Disconnect tailgate connecting rod and tailgate lock (if necessary).

INSTALLATION

Installation is in the reverse order of removal.

CAUTION:

After installation, check that tailgate locks and unlocks normally. Refer to [DLK-178, "TAILGATE LOCK : Inspection"](#).

TAILGATE LOCK : Inspection

INFOID:000000013000198

1. After opening and closing the tailgate, check that tailgate is fixed to the vehicle body normally.
2. Check the lock/unlock operation of tailgate.
3. Check tailgate lock for poor lubrication. Apply multi-purpose grease if necessary.

TAILGATE HANDLE

TAILGATE HANDLE : Removal and Installation

INFOID:000000013055559

REMOVAL

1. Remove tailgate finisher. Refer to [EXT-46, "Removal and Installation"](#).
2. Disconnect harness connector from rear camera (if equipped).
3. Remove bolts (A) and tailgate handle.

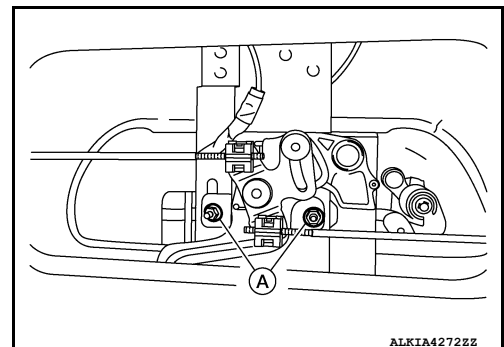

TAILGATE LOCK

< REMOVAL AND INSTALLATION >

4. Release pawls then disengage tailgate lock connecting rods (2) (LH/RH) from tailgate control (A) and remove tailgate control (if necessary).

(1) :Tailgate control retainer

○ :Pawl

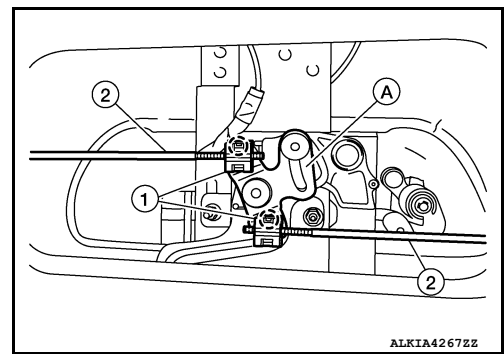

5. Remove bolt (A) and tailgate key cylinder [1 (if necessary)].

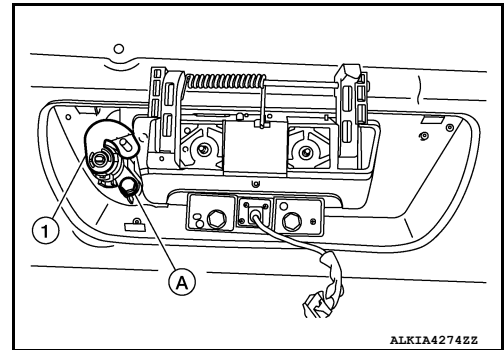

INSTALLATION

Installation is in the reverse order of removal.

CAUTION:

- After installation, check that tailgate locks and unlocks normally. Refer to [DLK-178, "TAILGATE LOCK : Inspection"](#).
- Perform camera image calibration (if equipped with around view monitor). Refer to [AV-331, "Description"](#).

A
B
C
D
E
F
G
H
I
J
L
M
N
O
P

DLK

FUEL FILLER LID

< REMOVAL AND INSTALLATION >

FUEL FILLER LID

Exploded View

INFOID:000000013000199

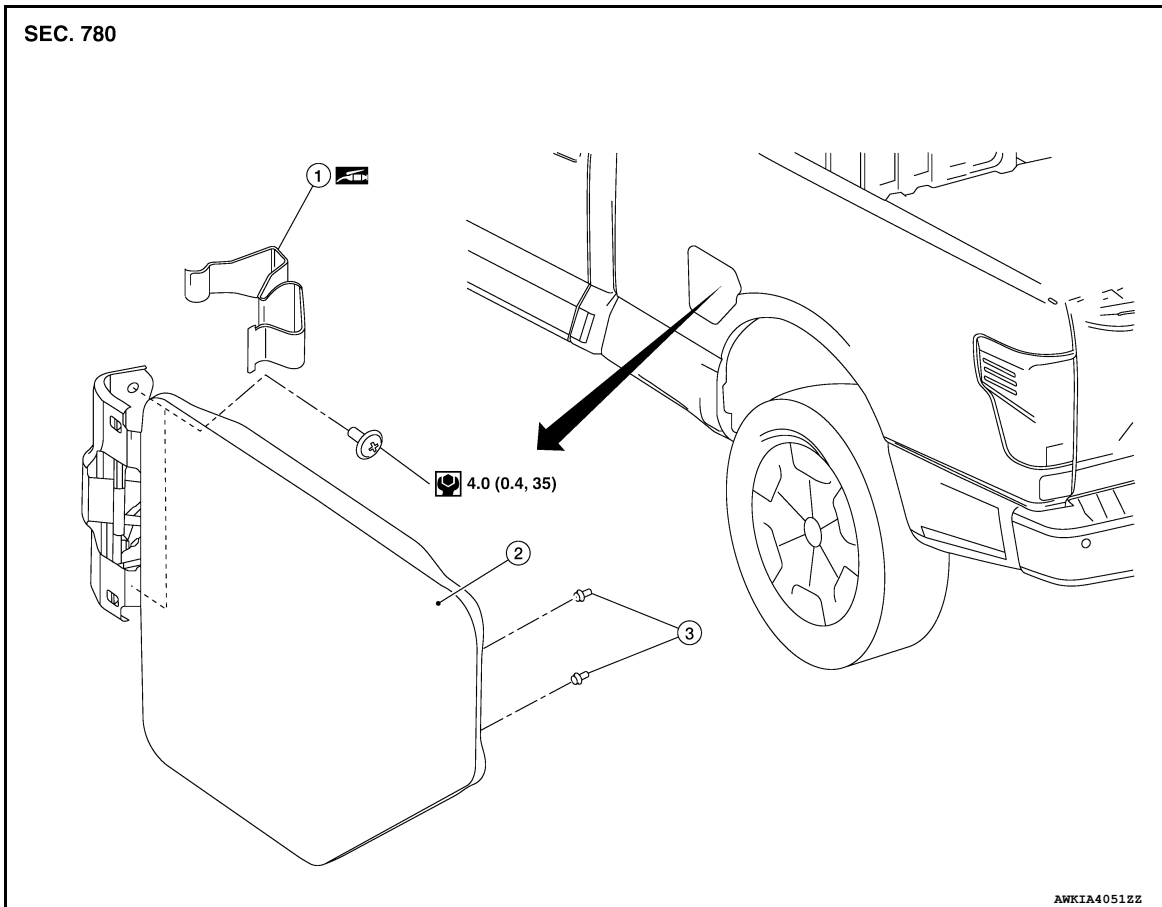

1. Fuel filler lid spring

2. Fuel filler lid

3. Bumper rubber

FUEL FILLER LID

FUEL FILLER LID : Removal and Installation

INFOID:000000013000200

REMOVAL

1. Fully open fuel filler lid.
2. Remove fuel filler lid spring (1).

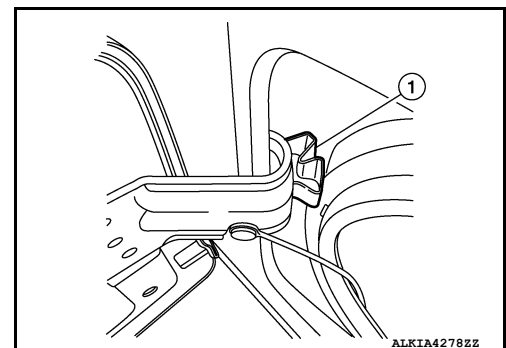

FUEL FILLER LID

< REMOVAL AND INSTALLATION >

3. Remove fuel cap pin (1).

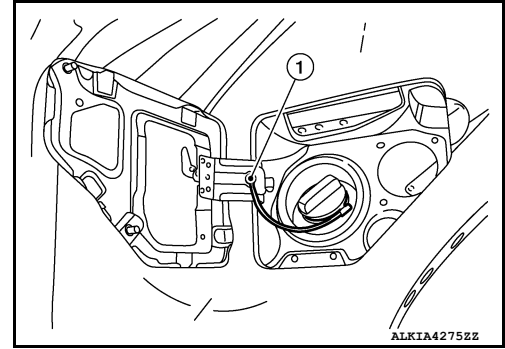

4. Remove screws (A), and remove fuel filler lid.

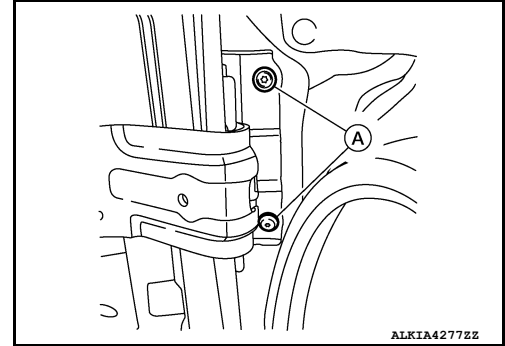

INSTALLATION

Installation is in the reverse order of removal.

CAUTION:

After installation, check fuel filler lid assembly open/close and lock/unlock operation.

NOTE:

The following table shows the specified values for checking normal installation status.
Fitting adjustment cannot be performed.

Unit: mm [in]		
Portion	Clearance	Surface Height
Fuel filler lid – Side panel	3.5 ±1.0 (0.14 ±0.04)	0.5 ± 1.0 (0.02 ±0.04)

A
B
C
D
E
F
G
H
I
J
L
M
N
O
P

DLK

KEY CYLINDER

< REMOVAL AND INSTALLATION >

KEY CYLINDER

GLOVE BOX LID KEY CYLINDER

GLOVE BOX LID KEY CYLINDER : Removal and Installation

INFOID:000000013055633

REMOVAL

1. Insert key (1) into glove box lid lock cylinder (2).
2. Pull upward on glove box lid release handle (3).
3. Rotate key (1) and turn glove box lid key cylinder (2) to the lock position.

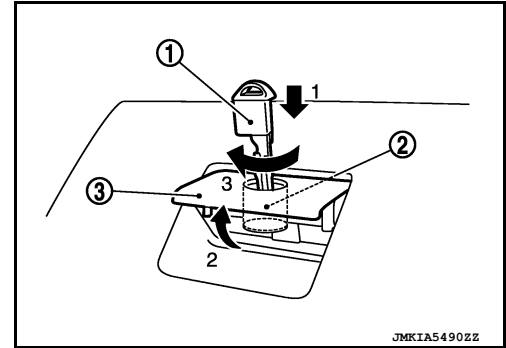

4. Press tumbler stopper (1) into glove box lid lock cylinder (2) using a suitable tool (A), and then remove key (3) and glove box lid lock cylinder together from glove box lid release handle (4).

NOTE:

When removing glove box lid lock cylinder (2) note the position of cylinder to glove box lid release handle (4).

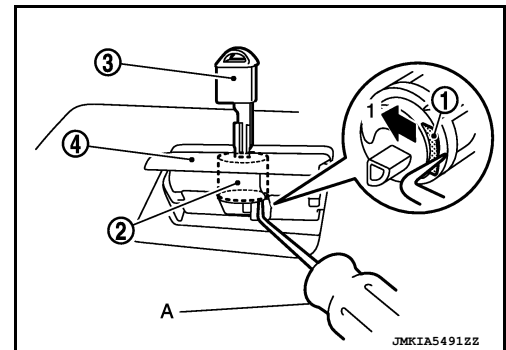

5. Remove sleeve (3) from glove box lid release handle and then install sleeve to glove box lid lock cylinder.

NOTE:

When removing sleeve note the position of sleeve to glove box lid release handle.

CAUTION:

Do not pull out key (1) from glove box lid lock cylinder (2) while sleeve (3) is removed. Otherwise, tumblers (4) may be lost from glove box lid lock cylinder.

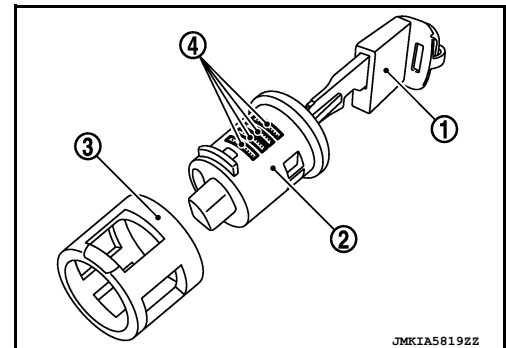

INSTALLATION

Installation is in the reverse order of removal.

CAUTION:

After installation, check glove box open/close, lock/unlock operation.

DOOR SWITCH

< REMOVAL AND INSTALLATION >

DOOR SWITCH

Removal and Installation

INFOID:000000013000203

REMOVAL

1. Remove the door switch bolt (A).
2. Disconnect door switch connector and remove door switch (1).

NOTE:

Front door shown rear door similar.

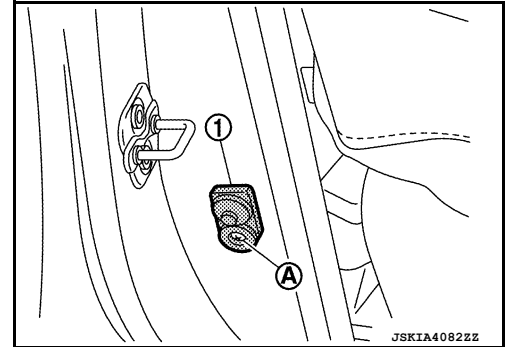

INSTALLATION

Installation is in the reverse order of removal.

Door switch bolt : 10.1 Nm (0.35 kg-m, 7 ft-lb)

A
B
C
D
E
F
G
H
I
J
L
M
N
O
P

DLK

INSIDE KEY ANTENNA

< REMOVAL AND INSTALLATION >

INSIDE KEY ANTENNA INSTRUMENT CENTER

INSTRUMENT CENTER : Removal and Installation

INFOID:000000013000206

REMOVAL

1. Remove cluster lid C lower. Refer to [JP-17, "CLUSTER LID C LOWER : Removal and Installation"](#).
2. Disconnect the harness connector from the inside key antenna (instrument center).
3. Remove inside key antenna (instrument center) screws (A), and then remove inside key antenna [instrument center (1)].

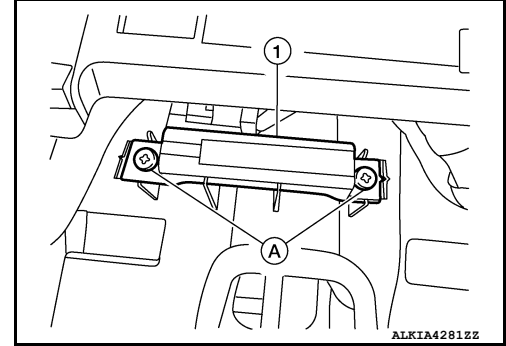

INSTALLATION

Installation is in the reverse order of removal.

CONSOLE

CONSOLE : Removal and Installation

INFOID:000000013000207

REMOVAL

1. Release clips using a suitable tool and remove center console rear finisher.

 : Clip

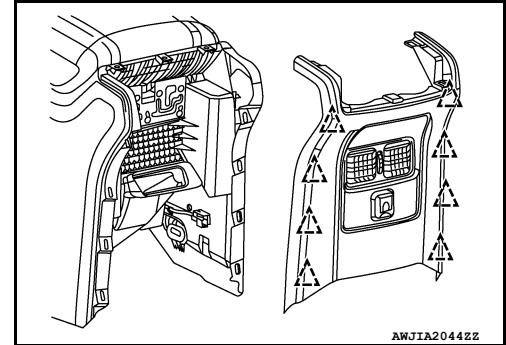

2. Remove screws (A), then remove inside key antenna [console (1)].

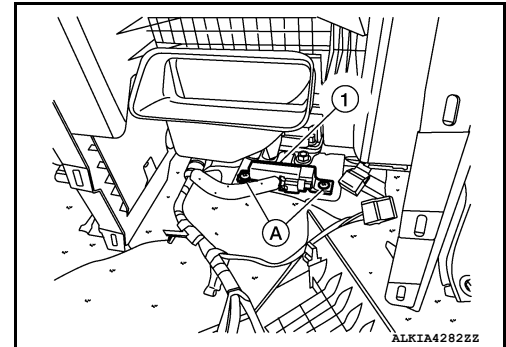

INSTALLATION

Installation is in the reverse order of removal.

OUTSIDE KEY ANTENNA

< REMOVAL AND INSTALLATION >

OUTSIDE KEY ANTENNA

OUTSIDE HANDLE

OUTSIDE HANDLE : Removal and Installation

INFOID:0000000013000208

REMOVAL

The outside key antenna is serviced as an assembly with the front outside handle grip. Refer to [DLK-169](#), "[OUTSIDE HANDLE : Removal and Installation](#)".

INSTALLATION

Installation is in the reverse order of removal.

A

B

C

D

E

F

G

H

I

J

DLK

L

M

N

O

P

DOOR REQUEST SWITCH

< REMOVAL AND INSTALLATION >

DOOR REQUEST SWITCH

DRIVER SIDE

DRIVER SIDE : Removal and Installation

INFOID:000000013197380

REMOVAL

The driver side door request switch and driver side outside handle are serviced as an assembly. Refer to [DLK-169, "OUTSIDE HANDLE : Removal and Installation"](#).

INSTALLATION

Installation is in the reverse order of removal.

PASSENGER SIDE

PASSENGER SIDE : Removal and Installation

INFOID:000000013197381

REMOVAL

The passenger side door request switch and passenger side outside handle are serviced as an assembly. Refer to [DLK-173, "OUTSIDE HANDLE : Removal and Installation"](#).

INSTALLATION

Installation is in the reverse order of removal.

INTELLIGENT KEY WARNING BUZZER

< REMOVAL AND INSTALLATION >

INTELLIGENT KEY WARNING BUZZER

Removal and Installation

INFOID:000000013000209

REMOVAL

1. Disconnect harness connector from the Intelligent Key warning buzzer (1).
2. Remove bolt (A) and Intelligent Key warning buzzer and bracket.

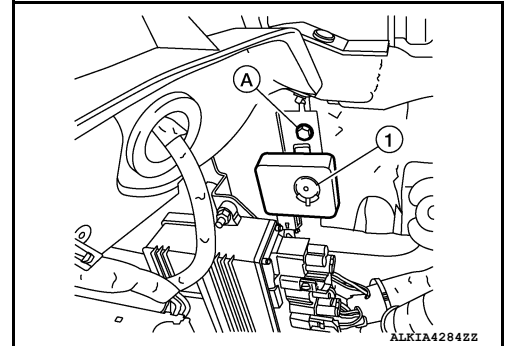

3. Remove Intelligent Key warning buzzer from bracket.

INSTALLATION

Installation is in the reverse order of removal.

A
B
C
D
E
F
G
H
I
J
L
M
N
O
P

DLK

REMOTE KEYLESS ENTRY RECEIVER

< REMOVAL AND INSTALLATION >

REMOTE KEYLESS ENTRY RECEIVER

Removal and Installation

INFOID:000000013000210

REMOVAL

1. Remove instrument upper panel. Refer to [IP-17. "INSTRUMENT UPPER PANEL : Removal and Installation"](#).
2. Disconnect the harness connector from the remote keyless entry receiver (1).
3. Remove screw (A) and remote keyless entry receiver.

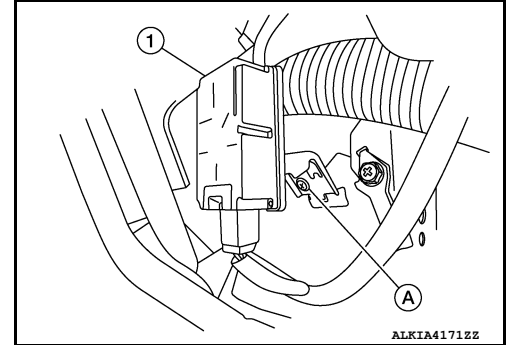

4. Remove remote keyless entry receiver from bracket.

INSTALLATION

Installation is in the reverse order of removal.

INTELLIGENT KEY BATTERY

< REMOVAL AND INSTALLATION >

INTELLIGENT KEY BATTERY

Removal and Installation

INFOID:000000013000211

1. Release lock knob on back of Intelligent Key and remove key.
2. Insert a suitable tool (A) wrapped with a cloth into slit of corner and twist it to separate upper part from lower part.

CAUTION:

- Do not insert a tool into notches of Intelligent Key to pry it open as this may damage circuit board.
- Do not use excessive force when opening Intelligent Key as this may result in damage to internal components.
- Do not touch circuit board or battery terminal.
- Key fob is water-resistant. However, if it does get wet, immediately wipe it dry.

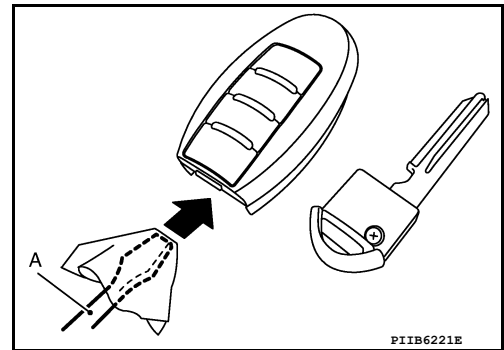

3. Replace battery with a new one.

Battery replacement

:Coin-type lithium battery (CR2032)

4. Align tips of upper and lower parts, and then push them together until unit is securely closed.

CAUTION:

- When replacing battery, keep dirt, grease, and other foreign materials off electrode contact area.
- After replacing battery, check that all Intelligent Key functions work normally.

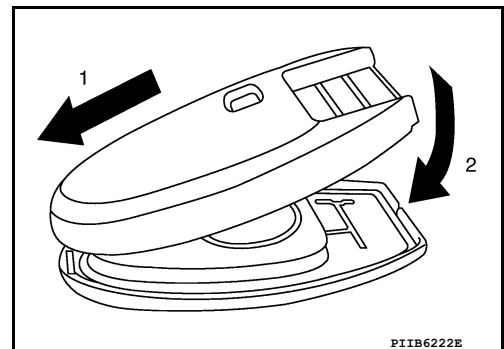

A
B
C
D
E
F
G
H
I
J
DLK
L
M
N
O
P