

SECTION **BRC**

BRAKE CONTROL SYSTEM

A
B
C
D
E

CONTENTS

ABS		BRC
SERVICE INFORMATION	3	
PRECAUTIONS	3	
Precaution for Supplemental Restraint System (SRS) "AIR BAG" and "SEAT BELT PRE-TENSIONER"	3	
Precaution Necessary for Steering Wheel Rotation After Battery Disconnect	3	
Precaution for Brake System	4	
Precaution for Brake Control	4	
Precaution for CAN System	4	
PREPARATION	6	
Special Service Tool	6	
Commercial Service Tool	6	
SYSTEM DESCRIPTION	7	
System Component	7	
ABS Function	7	
EBD Function	7	
Fail-Safe Function	7	
Hydraulic Circuit Diagram	8	
CAN COMMUNICATION	9	
System Description	9	
TROUBLE DIAGNOSIS	10	
How to Perform Trouble Diagnosis for Quick and Accurate Repair	10	
Component Parts and Harness Connector Location	13	
Schematic	14	
Wiring Diagram - ABS -	15	
Basic Inspection	18	
Warning Lamp and Indicator Timing	19	
Control Unit Input/Output Signal Standard	19	
CONSULT-III Function (ABS)	20	
TROUBLE DIAGNOSIS FOR SELF-DIAGNOSTIC ITEMS	26	
Wheel Sensor System	26	
ABS Control Unit Inspection	27	
Solenoid Valve System Inspection	27	
Actuator Motor, Motor Relay, and Circuit Inspection	28	
ABS Control Unit Power and Ground Systems Inspection	29	
CAN Communication System Inspection	30	
TROUBLE DIAGNOSES FOR SYMPTOMS	31	
ABS Works Frequently	31	
Unexpected Pedal Action	31	
Long Stopping Distance	32	
ABS Does Not Work	32	
Pedal Vibration or ABS Operation Noise	32	
WHEEL SENSORS	34	
Removal and Installation	34	
SENSOR ROTOR	36	
Removal and Installation	36	
ACTUATOR AND ELECTRIC UNIT (ASSEMBLY)	37	
Removal and Installation	37	
VDC/TCS/ABS		
SERVICE INFORMATION	39	
PRECAUTIONS	39	
Precaution for Supplemental Restraint System (SRS) "AIR BAG" and "SEAT BELT PRE-TENSIONER"	39	
Precaution Necessary for Steering Wheel Rotation After Battery Disconnect	39	
Precaution for Brake System	40	
Precaution for Brake Control	40	
Precaution for CAN System	41	
PREPARATION	42	
Special Service Tool	42	
Commercial Service Tool	42	

G
H
I
J
K
L
M

N
O
P

SYSTEM DESCRIPTION	43	ABS/TCS/VDC Control Unit Power and Ground	
System Component	43	Systems Inspection	75
ABS Function	43	Brake Fluid Level Switch System Inspection	76
EBD Function	43	Pressure Sensor System Inspection	77
TCS Function	44	Transmission Range Switch System Inspection	78
VDC Function	44	CAN Communication System Inspection	79
Wheel Sensors	44	Component Inspection	79
Fail-Safe Function	44		
Hydraulic Circuit Diagram	45		
CAN COMMUNICATION	46	TROUBLE DIAGNOSES FOR SYMPTOMS	81
System Description	46	ABS Works Frequently	81
		Unexpected Pedal Action	81
		Long Stopping Distance	82
		ABS Does Not Work	82
		Pedal Vibration or ABS Operation Noise	82
		ABS Warning Lamp Does Not Come On When Ig-	
		nition Switch Is Turned On	83
		ABS Warning Lamp Stays On When Ignition	
		Switch Is Turned On	83
		Vehicle Jerks During TCS/VDC Activation	84
TROUBLE DIAGNOSIS	47	ON-VEHICLE SERVICE	85
How to Perform Trouble Diagnosis for Quick and		Adjustment of Steering Angle Sensor Neutral Po-	
Accurate Repair	47	sition	85
Component Parts and Harness Connector Loca-			
tion	50	WHEEL SENSORS	86
Schematic	51	Removal and Installation	86
Wiring Diagram - VDC -	52		
Basic Inspection	56	SENSOR ROTOR	88
Warning Lamp and Indicator Timing	57	Removal and Installation	88
Control Unit Input/Output Signal Standard	57		
CONSULT-III Function (ABS)	60	ACTUATOR AND ELECTRIC UNIT (ASSEM-	
		BLY)	89
TROUBLE DIAGNOSIS FOR SELF-DIAG-		Removal and Installation	89
NOSTIC ITEMS	67	STEERING ANGLE SENSOR	91
Wheel Sensor System Inspection	67	Removal and Installation	91
Engine System Inspection	68		
ABS/TCS/VDC Control Unit Inspection	68	G SENSOR	92
Steering Angle Sensor System Inspection	69	Removal and Installation	92
Yaw Rate/Side/Decel G Sensor System Inspec-			
tion	70		
Solenoid and VDC Change-Over Valve System			
Inspection	72		
Actuator Motor, Motor Relay, and Circuit Inspec-			
tion	73		
Stop Lamp Switch System Inspection	74		

SERVICE INFORMATION

PRECAUTIONS

Precaution for Supplemental Restraint System (SRS) "AIR BAG" and "SEAT BELT PRE-TENSIONER"

INFOID:000000005397020

The Supplemental Restraint System such as "AIR BAG" and "SEAT BELT PRE-TENSIONER", used along with a front seat belt, helps to reduce the risk or severity of injury to the driver and front passenger for certain types of collision. This system includes seat belt switch inputs and dual stage front air bag modules. The SRS system uses the seat belt switches to determine the front air bag deployment, and may only deploy one front air bag, depending on the severity of a collision and whether the front occupants are belted or unbelted. Information necessary to service the system safely is included in the SRS and SB section of this Service Manual.

WARNING:

- To avoid rendering the SRS inoperative, which could increase the risk of personal injury or death in the event of a collision which would result in air bag inflation, all maintenance must be performed by an authorized NISSAN/INFINITI dealer.
- Improper maintenance, including incorrect removal and installation of the SRS can lead to personal injury caused by unintentional activation of the system. For removal of Spiral Cable and Air Bag Module, see the SRS section.
- Do not use electrical test equipment on any circuit related to the SRS unless instructed to in this Service Manual. SRS wiring harnesses can be identified by yellow and/or orange harnesses or harness connectors.

PRECAUTIONS WHEN USING POWER TOOLS (AIR OR ELECTRIC) AND HAMMERS

WARNING:

- When working near the Airbag Diagnosis Sensor Unit or other Airbag System sensors with the Ignition ON or engine running, DO NOT use air or electric power tools or strike near the sensor(s) with a hammer. Heavy vibration could activate the sensor(s) and deploy the air bag(s), possibly causing serious injury.
- When using air or electric power tools or hammers, always switch the Ignition OFF, disconnect the battery, and wait at least 3 minutes before performing any service.

Precaution Necessary for Steering Wheel Rotation After Battery Disconnect

INFOID:000000006044767

NOTE:

- This Procedure is applied only to models with Intelligent Key system and NATS (NISSAN ANTI-THEFT SYSTEM).
- Remove and install all control units after disconnecting both battery cables with the ignition knob in the "LOCK" position.
- Always use CONSULT-III to perform self-diagnosis as a part of each function inspection after finishing work. If DTC is detected, perform trouble diagnosis according to self-diagnostic results.

For models equipped with the Intelligent Key system and NATS, an electrically controlled steering lock mechanism is adopted on the key cylinder.

For this reason, if the battery is disconnected or if the battery is discharged, the steering wheel will lock and steering wheel rotation will become impossible.

If steering wheel rotation is required when battery power is interrupted, follow the procedure below before starting the repair operation.

OPERATION PROCEDURE

1. Connect both battery cables.

NOTE:

Supply power using jumper cables if battery is discharged.

2. Use the Intelligent Key or mechanical key to turn the ignition switch to the "ACC" position. At this time, the steering lock will be released.
3. Disconnect both battery cables. The steering lock will remain released and the steering wheel can be rotated.
4. Perform the necessary repair operation.

A
B
C
D
E
BRC
G
H
I
J
K
L
M
N
O
P

PRECAUTIONS

[ABS]

< SERVICE INFORMATION >

- When the repair work is completed, return the ignition switch to the "LOCK" position before connecting the battery cables. (At this time, the steering lock mechanism will engage.)
- Perform a self-diagnosis check of all control units using CONSULT-III.

Precaution for Brake System

INFOID:000000005397021

CAUTION:

- Refer to [MA-14](#) for recommended brake fluid.
- Never reuse drained brake fluid.
- Be careful not to splash brake fluid on painted areas; it may cause paint damage. If brake fluid is splashed on painted areas, wash it away with water immediately.
- To clean or wash all parts of master cylinder and disc brake caliper, use clean brake fluid.
- Never use mineral oils such as gasoline or kerosene. They will ruin rubber parts of the hydraulic system.
- Use flare nut wrench when removing and installing brake tube.
- If a brake fluid leak is found, the part must be disassembled without fail. Then it has to be replaced with a new one if a defect exists.
- Turn the ignition switch OFF and remove the connector of the ABS actuator and electric unit (control unit) or the battery terminal before performing the work.
- Always torque brake lines when installing.
- Burnish the brake contact surfaces after refinishing or replacing rotors, after replacing pads, or if a soft pedal occurs at very low mileage. Refer to [BR-34](#), "[Brake Burnishing Procedure](#)".

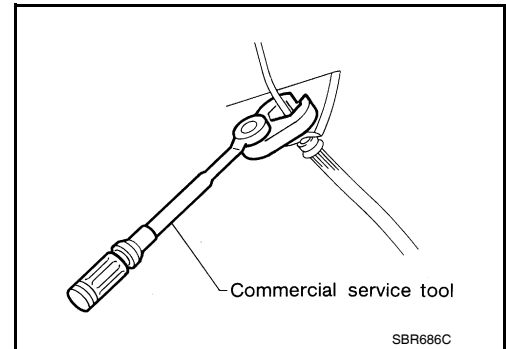

WARNING:

- Clean brake pads and shoes with a waste cloth, then wipe with a dust collector.

Precaution for Brake Control

INFOID:000000005397022

- During ABS operation, the brake pedal may vibrate lightly and a mechanical noise may be heard. This is normal.
- Just after starting the vehicle, the brake pedal may vibrate or motor operating noises may be heard from engine compartment. This is normal due to the self check operation.
- Stopping distance may be longer than that of vehicles without ABS when vehicle drives on rough, gravel, or snow-covered (fresh, deep snow) roads.
- When an error is indicated by ABS or another warning lamp, collect all necessary information from customer (what symptoms are present under what conditions) and check for simple causes before starting diagnosis. Besides electrical system inspection, check brake booster operation, brake fluid level, and fluid leaks.
- If incorrect tire sizes or types are installed on the vehicle or brake pads are not Genuine NISSAN parts, stopping distance or steering stability may deteriorate.
- If there is a radio, antenna or related wiring near the control module, ABS function may have a malfunction or error.
- If aftermarket parts (car stereo, CD player, etc.) have been installed, check for incidents such as harness pinches, open circuits or improper wiring.

Precaution for CAN System

INFOID:000000005397023

- Do not apply voltage of 7.0V or higher to terminal to be measured.
- Maximum open terminal voltage of tester in use must be less than 7.0V.
- Before checking harnesses, turn ignition switch OFF and disconnect battery negative cable.

PRECAUTIONS

[ABS]

< SERVICE INFORMATION >

- Area to be repaired must be soldered and wrapped with tape. Make sure that fraying of twisted wire is within 110 mm (4.33 in).

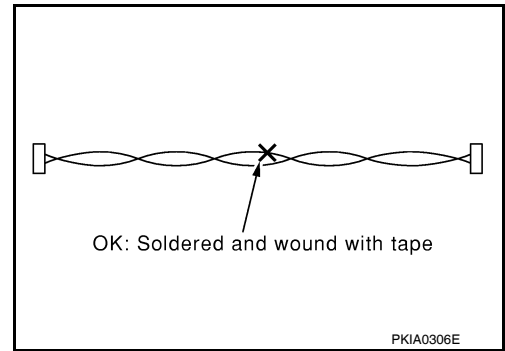

- Do not make a bypass connection to repaired area. (If the circuit is bypassed, characteristics of twisted wire will be lost.)

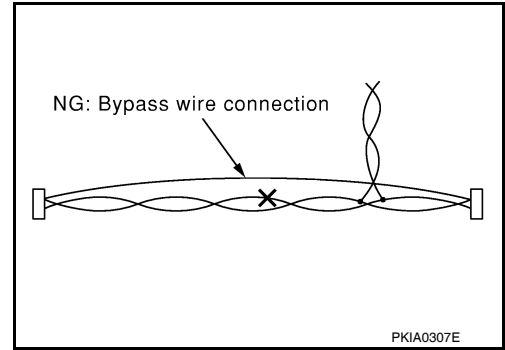

A
B
C
D
E
BRC
G
H
I
J
K
L
M
N
O
P

PREPARATION

< SERVICE INFORMATION >

[ABS]

PREPARATION

Special Service Tool

INFOID:000000005397024

The actual shapes of Kent-Moore tools may differ from those of special service tools illustrated here.

Tool number (Kent-Moore No.) Tool name	Description
KV991J0080 (J-45741) ABS active wheel sensor tester	Checking operation of ABS active wheel sensors

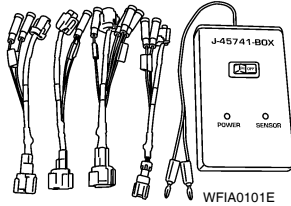

Commercial Service Tool

INFOID:000000005397025

Tool name	Description
1. Flare nut crowfoot 2. Torque wrench	Removing and installing brake piping a: 10 mm (0.39 in)/12 mm (0.47 in)

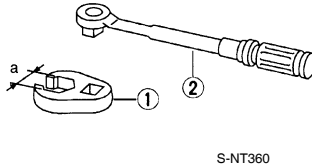

SYSTEM DESCRIPTION

System Component

INFOID:000000005397026

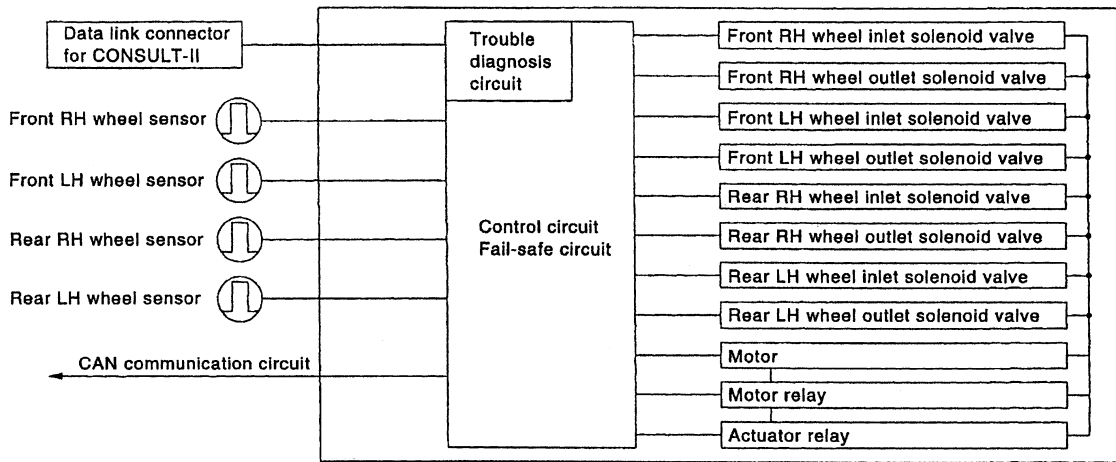

ABS actuator and control unit

WFIA0118E

ABS Function

INFOID:000000005397027

- The Anti-Lock Brake System detects wheel revolution while braking and improves handling stability during sudden braking by electrically preventing wheel lockup. Maneuverability is also improved for avoiding obstacles during emergency braking.
- If the electrical system malfunctions, the Fail-Safe function is activated, the ABS becomes inoperative and the ABS warning lamp turns on.
- The electrical system can be diagnosed using CONSULT-III.
- During ABS operation, the brake pedal may vibrate lightly and a mechanical noise may be heard. This is normal.
- Just after starting the vehicle, the brake pedal may vibrate or motor operating noises may be heard from the engine compartment. This is normal due to the self check operation.
- Stopping distance may be longer than that of vehicles without ABS when vehicle drives on rough, gravel, or snow-covered (fresh, deep snow) roads.

EBD Function

INFOID:000000005397028

- Electronic Brake Distribution is a function that detects subtle slippages between the front and rear wheels during braking, and it improves handling stability by electronically controlling the brake fluid pressure which results in reduced rear wheel slippage.
- If the electrical system malfunctions, the Fail-Safe function is activated, the EBD and ABS become inoperative, and the ABS warning lamp and brake warning lamp are turned on.
- The electrical system can be diagnosed using CONSULT-III.
- During EBD operation, the brake pedal may vibrate lightly and a mechanical noise may be heard. This is normal.
- Just after starting the vehicle, the brake pedal may vibrate or motor operating noises may be heard from the engine compartment. This is normal due to the self check operation.

Fail-Safe Function

INFOID:000000005397029

CAUTION:

If the Fail-Safe function is activated, perform the Self Diagnosis for ABS system.

ABS/EBD SYSTEM

In case of an electrical malfunction with the ABS, the ABS warning lamp will turn on. In case of an electrical malfunction with the EBD system, the brake warning lamp and the ABS warning lamp will turn on. The system will revert to one of the following conditions of the Fail-Safe function.

1. For ABS malfunction, only the EBD is operative and the condition of the vehicle is the same condition of vehicles without ABS system.

SYSTEM DESCRIPTION

[ABS]

< SERVICE INFORMATION >

- For EBD malfunction, the EBD and ABS become inoperative, and the condition of the vehicle is the same as the condition of vehicles without ABS or EBD system.

Hydraulic Circuit Diagram

INFOID:000000005397030

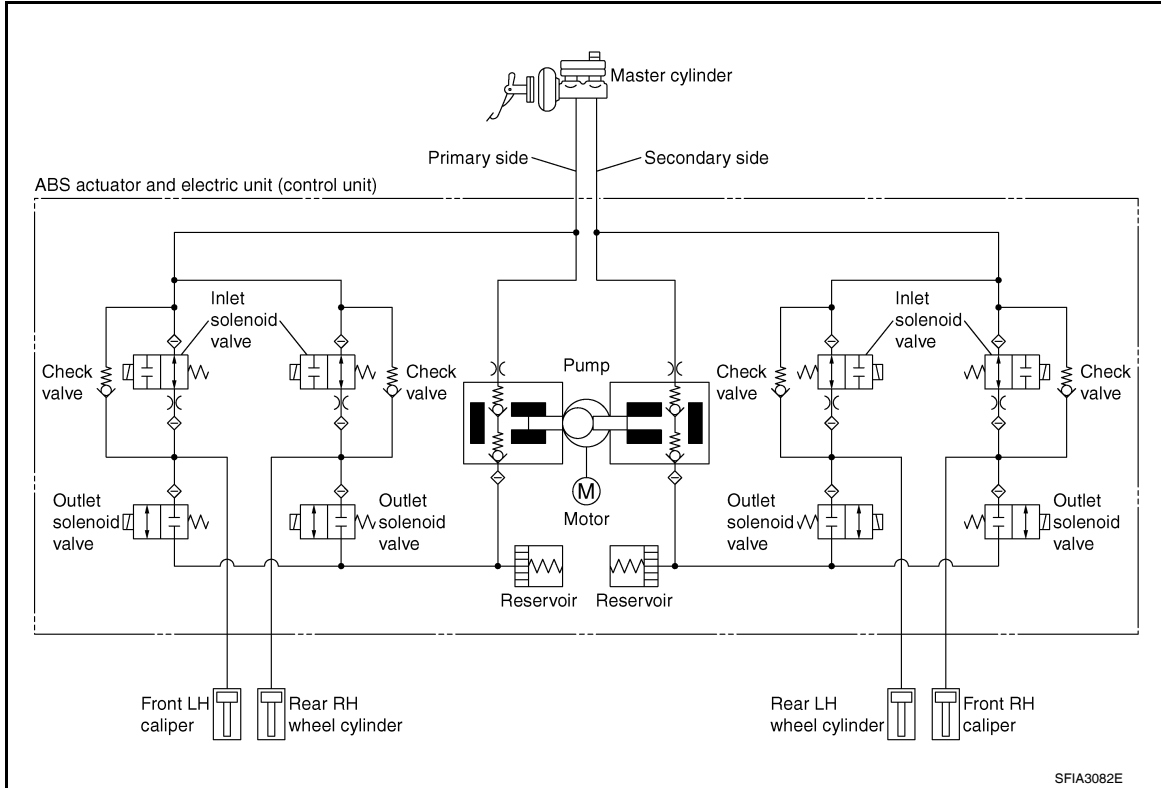

CAN COMMUNICATION

< SERVICE INFORMATION >

[ABS]

CAN COMMUNICATION

System Description

INFOID:000000005397031

Refer to [LAN-7. "System Description"](#).

A

B

C

D

E

BRC

G

H

I

J

K

L

M

N

O

P

TROUBLE DIAGNOSIS

How to Perform Trouble Diagnosis for Quick and Accurate Repair

INFOID:000000005397032

INTRODUCTION

The ABS system has an electronic control unit to control major functions. The control unit accepts input signals from sensors and controls actuator operation. It is also important to check for air leaks in the booster or brake and vacuum lines, lack of brake fluid, or other malfunctions in the brake system.

It is much more difficult to diagnose a malfunction that occurs intermittently rather than continuously. Most intermittent conditions are caused by poor electrical connections or damaged wiring. In this case, careful checking of suspicious circuits may help prevent the replacement of good parts.

A visual check only may not find the cause of the malfunction, so a road test should be performed.

Before undertaking actual checks, take just a few minutes to talk with a customer who approaches with an ABS complaint. The customer is a very good source of information, especially for intermittent conditions. Through the talks with the customer, find out what symptoms are present and under what conditions they occur.

Start your diagnosis by looking for "conventional" malfunctions first. This is one of the best ways to troubleshoot brake malfunctions on an ABS equipped vehicle. Also check related Service Bulletins for information.

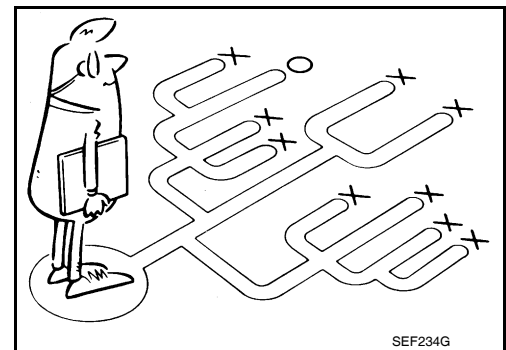
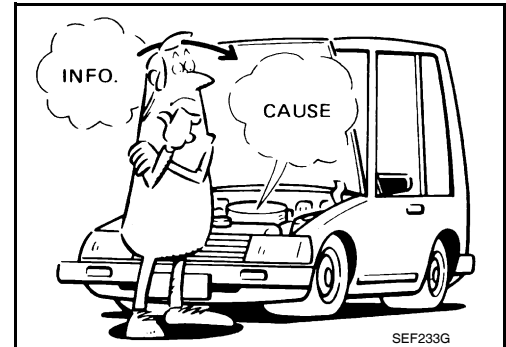

TROUBLE DIAGNOSIS

[ABS]

< SERVICE INFORMATION >

WORK FLOW

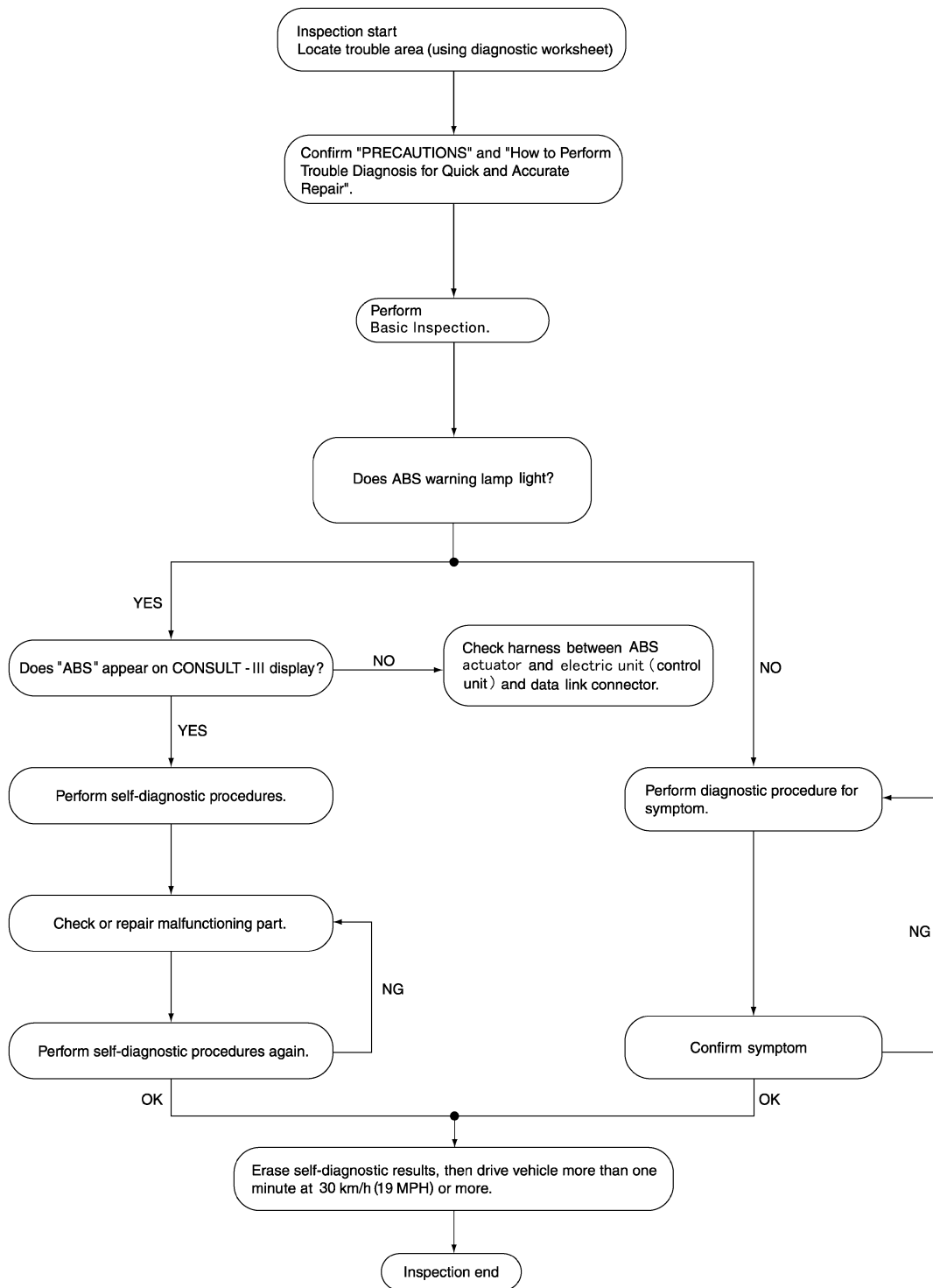

A
B
C
D
E
BRC
G
H
I
J
K
L
M
N
O
P

AWFIA0086GB

CLARIFY CONCERN

TROUBLE DIAGNOSIS

[ABS]

< SERVICE INFORMATION >

- A customer's description of a vehicle concern may vary depending on the individual. It is important to clarify the customer's concern.
- Ask the customer about what symptoms are present under what conditions. Use this information to reproduce the symptom while driving.
- It is also important to use the diagnosis sheet to understand what type of symptoms the customer is experiencing.

KEY POINTS

WHAT Vehicle model
WHEN Date, Frequencies
WHERE Road conditions
HOW Operating conditions,
Weather conditions,
Symptoms

SBR339B

EXAMPLE OF DIAGNOSIS SHEET

Customer name MR/MS	Model & Year	VIN	
Engine #	Trans.	Mileage	
Incident Date	Manuf. Date	In Service Date	
Symptoms	<input type="checkbox"/> Noise and vibration (from engine compartment) <input type="checkbox"/> Noise and vibration (from axle)	<input type="checkbox"/> Warning / Indicator activate	<input type="checkbox"/> Firm pedal operation Large stroke pedal operation
	<input type="checkbox"/> ABS does not work (Wheels lock when braking)	<input type="checkbox"/> Lack of sense of acceleration	
Engine conditions	<input type="checkbox"/> When starting <input type="checkbox"/> After starting		
Road conditions	<input type="checkbox"/> Low friction road (<input type="checkbox"/> Snow <input type="checkbox"/> Gravel <input type="checkbox"/> Other) <input type="checkbox"/> Bumps / potholes		
Driving conditions	<input type="checkbox"/> Full-acceleration <input type="checkbox"/> High speed cornering <input type="checkbox"/> Vehicle speed: Greater than 10 km/h (6 MPH) <input type="checkbox"/> Vehicle speed: 10 km/h (6 MPH) or less <input type="checkbox"/> Vehicle is stopped		
Applying brake conditions	<input type="checkbox"/> Suddenly <input type="checkbox"/> Gradually		
Other conditions	<input type="checkbox"/> Operation of electrical equipment <input type="checkbox"/> Shift change <input type="checkbox"/> Other descriptions		

SFIA3264E

TROUBLE DIAGNOSIS

[ABS]

< SERVICE INFORMATION >

Component Parts and Harness Connector Location

INFOID:000000005397033

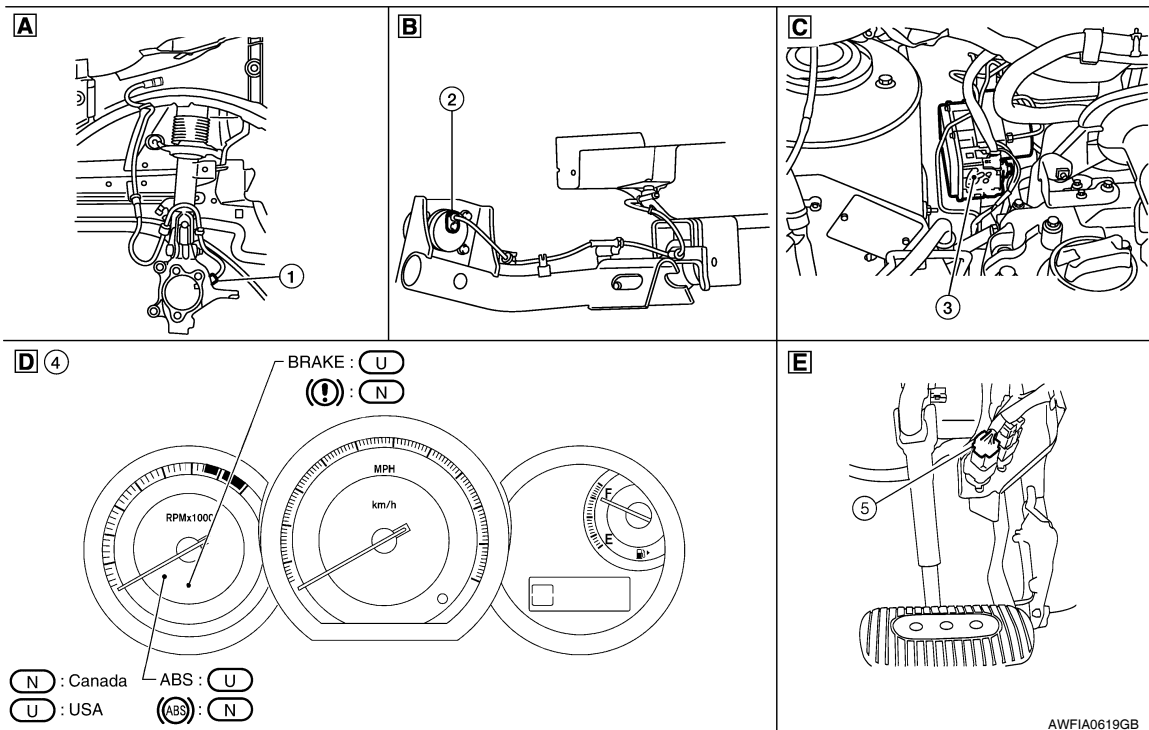
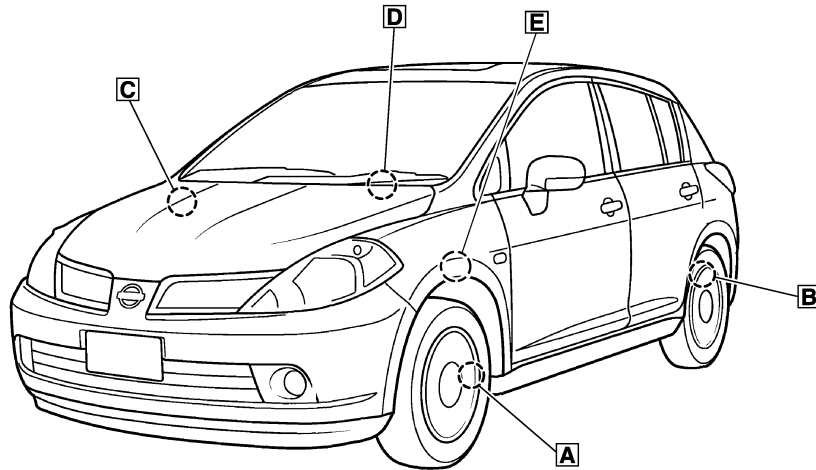

- | | | |
|--|--|--|
| 1. Front wheel sensor
LH E18
RH E117 | 2. Rear wheel sensor
LH B123
RH B122 | 3. ABS actuator and electric unit (control unit) E33 |
| 4. Combination meter M24 | 5. Stop lamp switch E13 | |

TROUBLE DIAGNOSIS

[ABS]

< SERVICE INFORMATION >

Schematic

INFOID:000000005397034

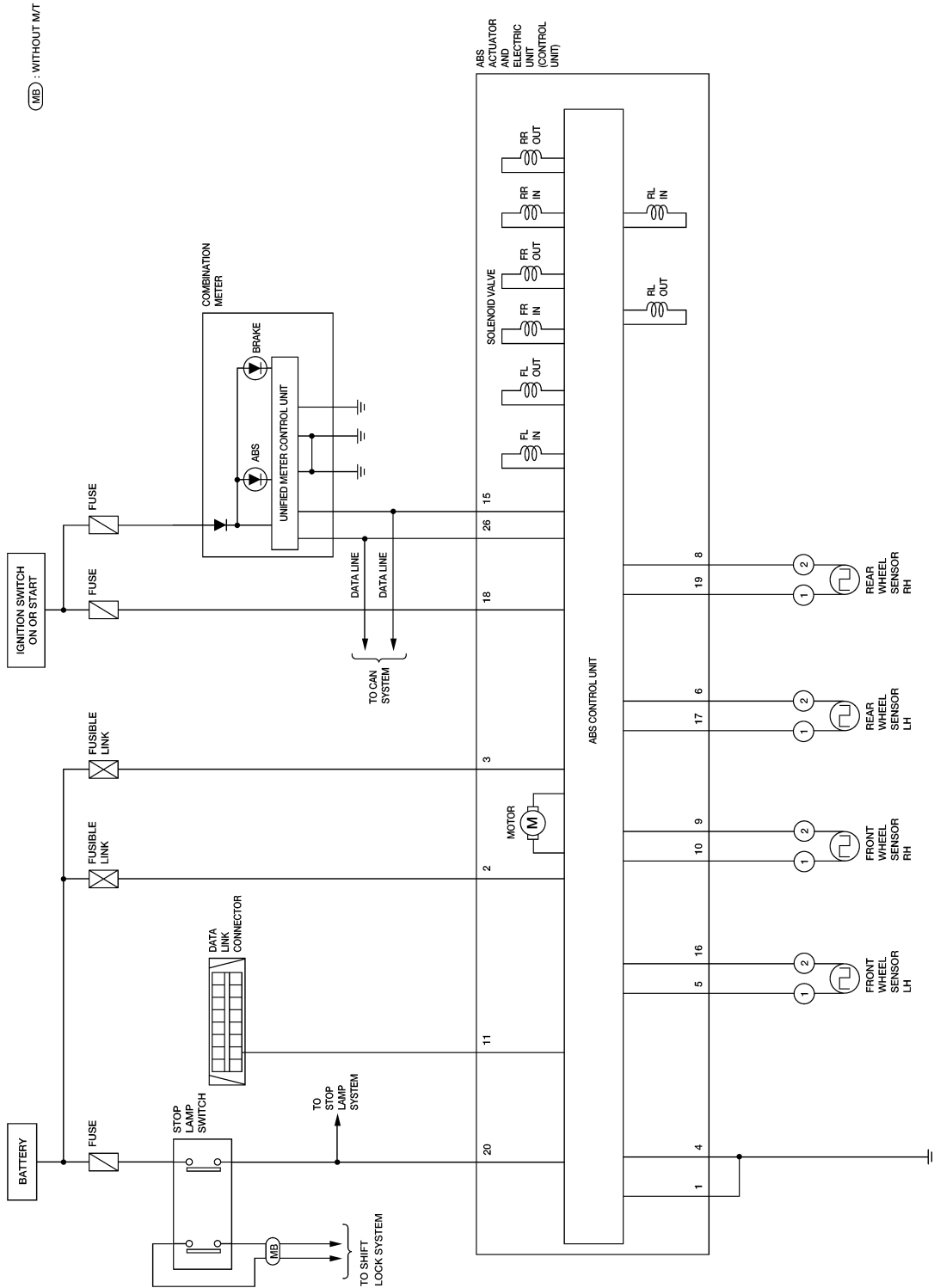

ABFWA0120GB

TROUBLE DIAGNOSIS

[ABS]

< SERVICE INFORMATION >

Wiring Diagram - ABS -

INFOID:000000005397035

BRC-ABS-01

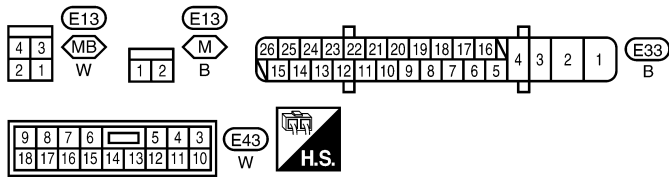
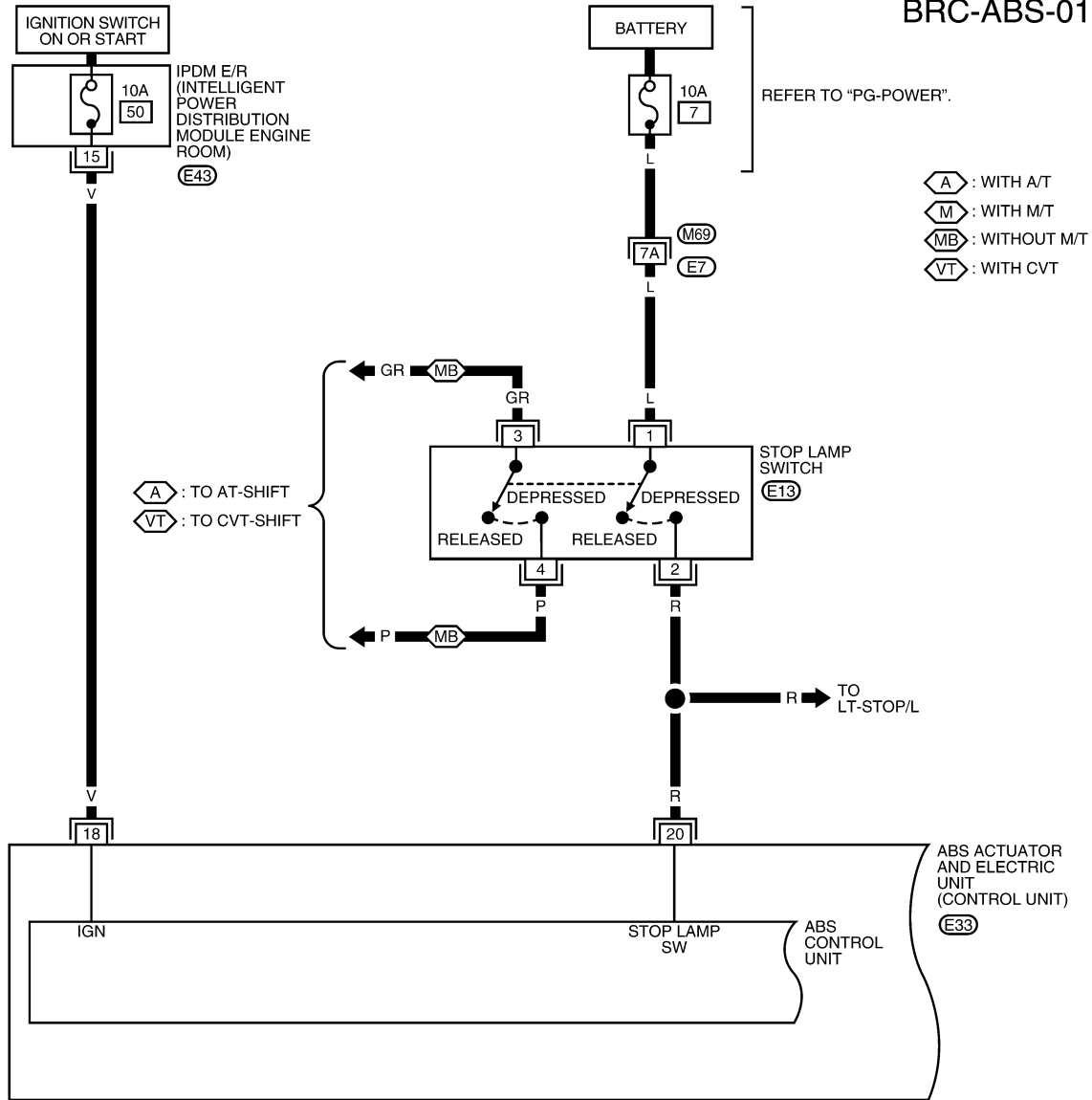

REFER TO THE FOLLOWING.
 (M69) - SUPER MULTIPLE JUNCTION (SMJ)

ABFWA0114GB

TROUBLE DIAGNOSIS

< SERVICE INFORMATION >

[ABS]

BRC-ABS-02

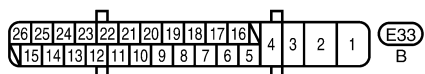
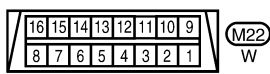
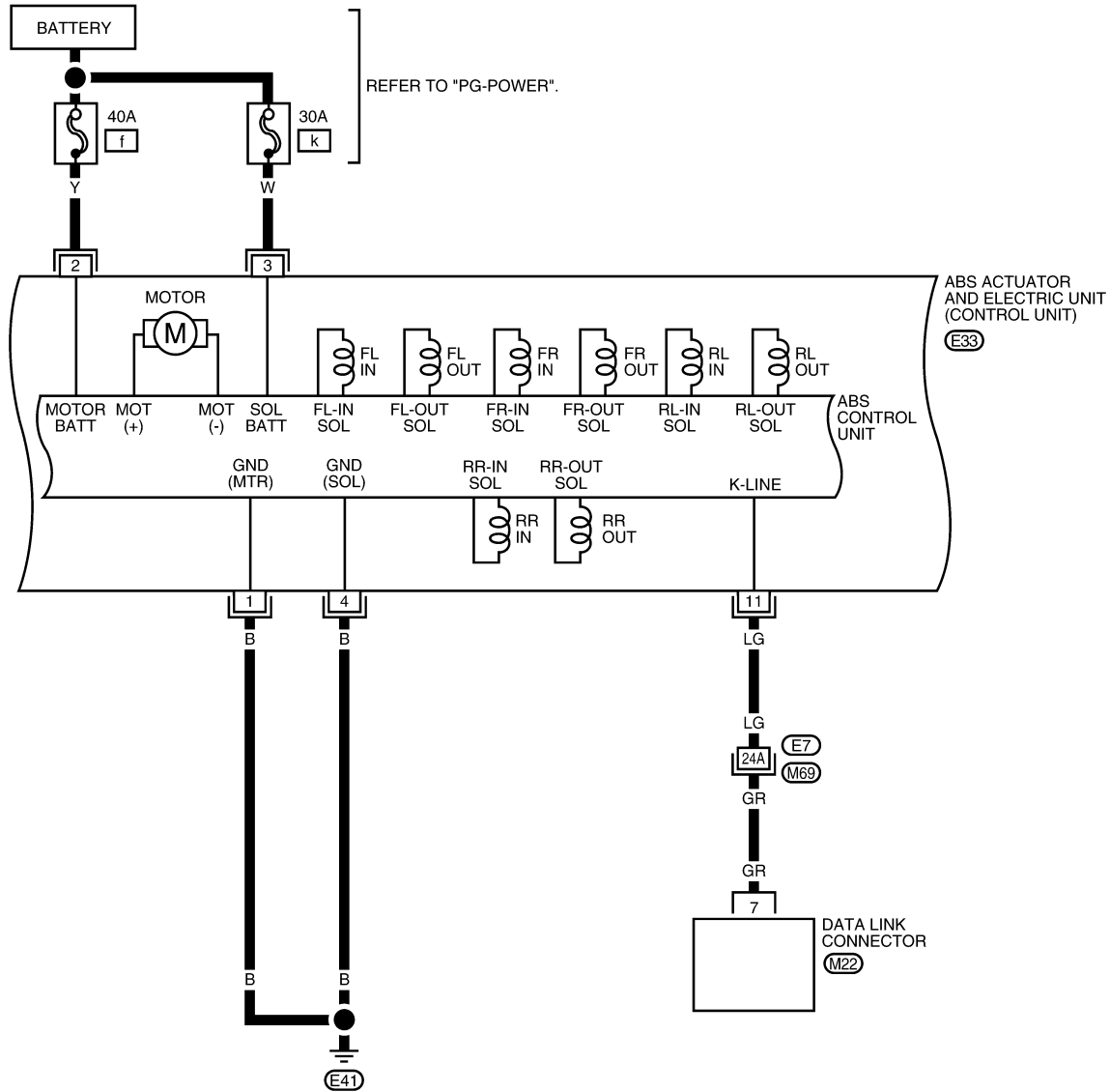

REFER TO THE FOLLOWING.
 (M69) - SUPER MULTIPLE JUNCTION (SMJ)

WFWA0420E

TROUBLE DIAGNOSIS

< SERVICE INFORMATION >

[ABS]

BRC-ABS-03

— : DATA LINE

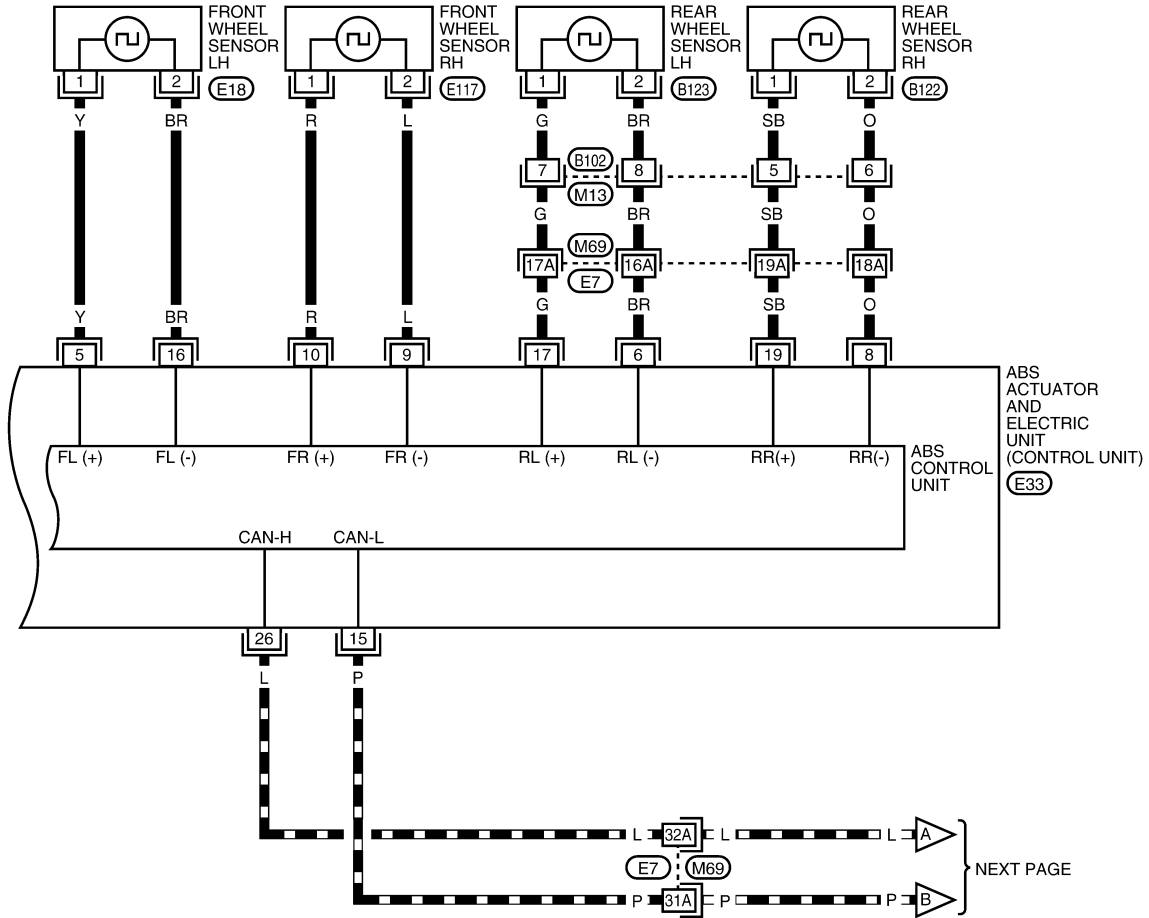

A
B
C
D
E
BRC
G
H
I
J
K
L
M
N
O
P

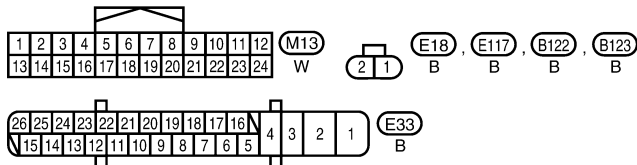

REFER TO THE FOLLOWING.
 (M69) - SUPER MULTIPLE
 JUNCTION (SMJ)

WFWA0421E

TROUBLE DIAGNOSIS

< SERVICE INFORMATION >

[ABS]

BRC-ABS-04

▬ : DATA LINE

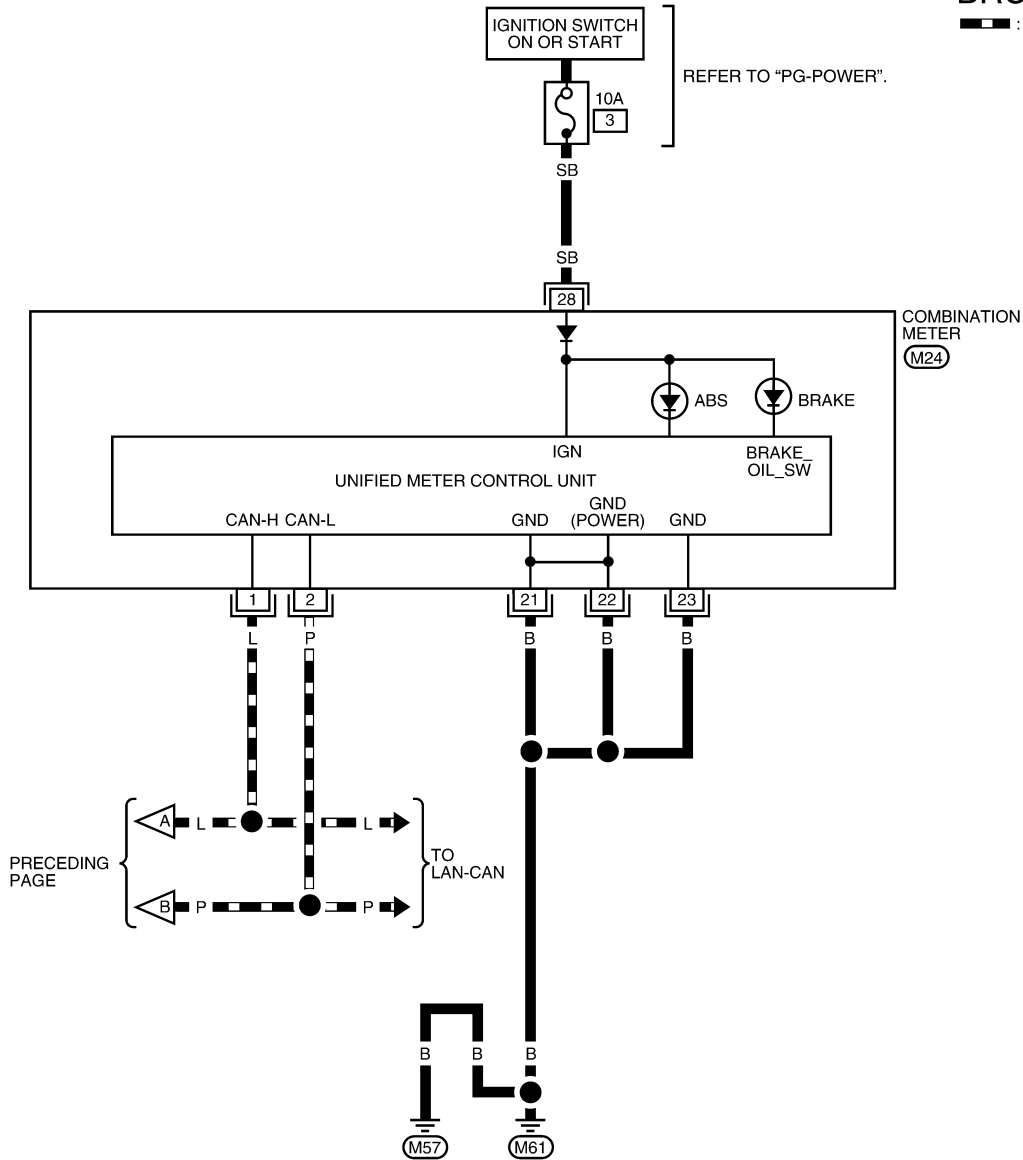

1	2	3	4	5	6	7	8	9	10	11	12	13	14	15	16	17	18	19	20	(M24)
21	22	23	24	25	26	27	28	29	30	31	32	33	34	35	36	37	38	39	40	W

ABFWA0121GB

Basic Inspection

INFOID:000000005397036

BRAKE FLUID LEVEL, FLUID LEAK, AND BRAKE PAD INSPECTION

1. Check fluid level in the brake fluid reservoir. If fluid level is low, add fluid.
2. Check the brake piping and around the ABS actuator and electric unit (control unit) for leaks. If there is leaking or seeping fluid, check the following items.

TROUBLE DIAGNOSIS

[ABS]

< SERVICE INFORMATION >

- If ABS actuator and electric unit (control unit) connection is loose, tighten the piping to the specified torque and recheck for leaks.
- If there is damage to the connection flare nut or ABS actuator and electric unit (control unit) threads, replace the damaged part and recheck for leaks.
- When there is fluid leaking or seeping from a fluid connection, use a clean cloth to wipe off the fluid and recheck for leaks. If fluid is still seeping out, replace the damaged part. If the fluid is leaking at the ABS actuator and electric unit (control unit), replace the ABS actuator and electric unit (control unit) assembly.

CAUTION:

The ABS actuator and electric unit (control unit) cannot be disassembled and must be replaced as an assembly.

3. Check the brake pads for excessive wear.

POWER SYSTEM TERMINAL LOOSENESS AND BATTERY INSPECTION

Make sure the battery positive cable, negative cable and ground connection are not loose. In addition, make sure the battery is sufficiently charged.

ABS WARNING LAMP INSPECTION

1. Make sure ABS warning lamp turns on for approximately 2 seconds when the ignition switch is turned ON. If it does not, check CAN communications. If there are no errors with the CAN communication system, replace the combination meter. Refer to [IP-12, "Removal and Installation"](#).
2. Make sure the lamp turns off approximately 2 seconds after the ignition switch is turned ON. If the lamp does not turn off, conduct self-diagnosis of ABS actuator and electric unit (control unit). If no malfunctions are detected in self-diagnosis, replace combination meter. Refer to [IP-12, "Removal and Installation"](#).
3. After conducting the self-diagnosis, be sure to erase the error memory. Refer to [BRC-20, "CONSULT-III Function \(ABS\)"](#).

Warning Lamp and Indicator Timing

INFOID:000000005397037

Condition	ABS warning lamp	BRAKE warning lamp [Note 1]	Remarks
When the ignition switch is OFF	–	–	–
After the ignition switch is turned ON for approx. 1 second	×	×	–
After the ignition switch is turned ON for approx. 2 seconds	–	–	Lamp goes off approx. 2 seconds after the engine is started.
ABS malfunction	×	–	–
EBD malfunction	×	×	–

Note 1: Brake warning lamp will turn on when the parking brake is applied or when the brake fluid level is low.

x: ON

–: OFF

Control Unit Input/Output Signal Standard

INFOID:000000005397038

REFERENCE VALUE FROM CONSULT-III

CAUTION:

The display shows the control unit calculation data, so a normal value might be displayed even in the event the output circuit (harness) is open or short circuited.

TROUBLE DIAGNOSIS

< SERVICE INFORMATION >

[ABS]

Monitor item	Display content	Data monitor		Note: Error inspection checklist
		Condition	Reference value in normal operation	
FR RH SENSOR FR LH SENSOR RR RH SENSOR RR LH SENSOR	Wheel speed	Vehicle stopped	0 [km/h (MPH)]	BRC-26, "Wheel Sensor System"
		Vehicle running (Note 1)	Almost in accordance with speedometer display (within ±10%)	
BATTERY VOLT	Battery voltage supplied to ABS actuator and electric unit (control unit)	Ignition switch ON	10 to 16V	BRC-29, "ABS Control Unit Power and Ground Systems Inspection"
STOP LAMP SW	Stop lamp switch operation	Brake pedal depressed	ON	—
		Brake pedal not depressed	OFF	
ABS WARN LAMP	ABS warning lamp ON condition (Note 2)	ABS warning lamp ON	ON	BRC-18, "Basic Inspection"
		ABS warning lamp OFF	OFF	
MOTOR RELAY	Operation status of motor and motor relay	Ignition switch ON or running (ABS not activated)	OFF	BRC-28, "Actuator Motor, Motor Relay, and Circuit Inspection"
		Ignition switch ON or engine running (ABS activated)	ON	
ACTUATOR RLY	Actuator relay operation status	Vehicle stopped (Ignition switch ON)	OFF	BRC-28, "Actuator Motor, Motor Relay, and Circuit Inspection"
		Vehicle stopped (Engine running)	ON	
FR LH IN SOL FR LH OUT SOL FR RH IN SOL FR RH OUT SOL RR RH IN SOL RR RH OUT SOL RR LH IN SOL RR LH OUT SOL	Solenoid valve operation	Actuator (solenoid) is active ("ACTIVE TEST" with CONSULT-III) or actuator relay is inactive (in fail-safe mode).	ON	BRC-27, "Solenoid Valve System Inspection"
		When actuator (solenoid) is not active and actuator relay is active (ignition switch ON).	OFF	
ABS SIGNAL EBD SIGNAL	Signal status	ABS active EBD active	ON	ABS system EBD system
		ABS not active EBD not active	OFF	
ABS FAIL SIG EBD FAIL SIG	Fail signal status	ABS fail EBD fail	ON	ABS system EBD system
		ABS normal EBD normal	OFF	

Note 1: Confirm tire pressure is normal.

Note 2: ON/OFF timing of ABS warning lamp

ON: For approximately 2 seconds after ignition switch is turned ON, or when a malfunction is detected.

OFF: Approximately 2 seconds after ignition switch is turned ON (when system is in normal operation).

CONSULT-III Function (ABS)

INFOID:000000005397039

CONSULT-III can display each diagnostic item using the diagnostic test modes shown following.

Diagnostic mode	Description
SELF DIAGNOSTIC RESULT	Displays ABS actuator and electric unit (control unit) self-diagnosis results.
DATA MONITOR	Displays ABS actuator and electric unit (control unit) input/output data in real time.
CAN DIAG SUPPORT MNTR	The result of transmit/receive diagnosis of CAN communication can be read.
ACTIVE TEST	Operation of electrical loads can be checked by sending drive signal to them.

TROUBLE DIAGNOSIS

[ABS]

< SERVICE INFORMATION >

Diagnostic mode	Description
FUNCTION TEST	Conducted by CONSULT-III instead of a technician to determine whether each system is "OK" or "NG".
ECU IDENTIFICATION	ABS actuator and electric unit (control unit) part number can be read.

SELF-DIAGNOSIS

Description

If an error is detected in the system, the ABS warning lamp will turn on. In this case, perform self-diagnosis as follows:

Operation Procedure

1. Turn ignition switch OFF.
2. Connect CONSULT-III to the data link connector.
3. Turn ignition switch ON.
4. Start engine and drive at approximately 30 km/h (19 MPH) or more for approximately 1 minute.
5. After stopping the vehicle, with the engine running, touch "ABS", "SELF-DIAG RESULTS" in order on the CONSULT-III screen.
6. The self-diagnostic results are displayed. (If necessary, the self-diagnostic results can be printed out by touching "PRINT".)
 - When "NO DTC IS DETECTED" is displayed, check the ABS warning lamp.
7. Conduct the appropriate inspection from the display item list, and repair or replace the malfunctioning component.
8. Start engine and drive at approximately 30 km/h (19 MPH) or more for approximately 1 minute.

CAUTION:

 - **When a wheel sensor "short-circuit" is detected, if the vehicle is not driven at 30 km/h (19 MPH) for at least 1 minute, the ABS warning lamp will not turn off even if the malfunction is repaired.**
9. Turn ignition switch OFF to prepare for erasing the memory.
10. Start the engine and touch "ABS", "SELF-DIAG RESULTS", "ERASE" in order on the CONSULT-III screen to erase the error memory.

If "ABS" is not indicated, go to [GI-36, "CONSULT-III Data Link Connector \(DLC\) Circuit"](#).

CAUTION:

If the error memory is not erased, re-conduct the operation from step 5.
11. For the final inspection, drive at approximately 30 km/h (19 MPH) or more for approximately 1 minute and confirm that the ABS warning lamp is off.

Display Item List

TROUBLE DIAGNOSIS

< SERVICE INFORMATION >

[ABS]

Self-diagnostic item	Malfunction detecting condition	Check system	
RR RH SENSOR-1 [C1101]	Circuit of rear RH wheel sensor is open.		
RR LH SENSOR-1 [C1102]	Circuit of rear LH wheel sensor is open.		
FR RH SENSOR-1 [C1103]	Circuit of front RH wheel sensor is open.		
FR LH SENSOR-1 [C1104]	Circuit of front LH wheel sensor is open.		
RR RH SENSOR-2 [C1105]	When the circuit in the rear RH wheel sensor is short-circuited or when the sensor power voltage is outside the standard. When the distance between the wheel sensor and sensor rotor is too large and the sensor pulse cannot be recognized by the control unit.		
RR LH SENSOR-2 [C1106]	When the circuit in the rear LH wheel sensor is short-circuited or when the sensor power voltage is outside the standard. When the distance between the wheel sensor and sensor rotor is too large and the sensor pulse cannot be recognized by the control unit.		BRC-26, "Wheel Sensor System" (Note 1)
FR RH SENSOR-2 [C1107]	When the circuit in the front RH wheel sensor is short-circuited or when the sensor power voltage is outside the standard. When the distance between the wheel sensor and sensor rotor is too large and the sensor pulse cannot be recognized by the control unit.		
FR LH SENSOR-2 [C1108]	When the circuit in the front LH wheel sensor is short-circuited or when the sensor power voltage is outside the standard. When the distance between the wheel sensor and sensor rotor is too large and the sensor pulse cannot be recognized by the control unit.		
ABS SENSOR [ABNORMAL SIGNAL] [C1115]	Wheel sensor input is abnormal.		
BATTERY VOLTAGE [ABNORMAL] [C1109]	ABS actuator and electric unit (control unit) power voltage is too low.		BRC-29, "ABS Control Unit Power and Ground Systems Inspection"
CONTROLLER FAILURE [C1110]	Internal malfunction of ABS actuator and electric unit (control unit)	BRC-27, "ABS Control Unit Inspection"	
PUMP MOTOR [C1111]	During actuator motor operation with ON, when actuator motor turns OFF or when control line for actuator motor relay is open.	BRC-28, "Actuator Motor, Motor Relay, and Circuit Inspection"	
	During actuator motor operation with OFF, when actuator motor turns ON or when control line for relay is shorted to ground.		
FR LH IN ABS SOL [C1120]	Circuit of front LH IN ABS solenoid is open or shorted, or control line is open or shorted to power supply or ground.	BRC-27, "Solenoid Valve System Inspection"	
FR LH OUT ABS SOL [C1121]	Circuit of front LH OUT ABS solenoid is open or shorted, or control line is open or shorted to power supply or ground.		
FR RH IN ABS SOL [C1122]	Circuit of front RH IN ABS solenoid is open or shorted, or control line is open or shorted to power supply or ground.		
FR RH OUT ABS SOL [C1123]	Circuit of front RH OUT ABS solenoid is open or shorted, or control line is open or shorted to power supply or ground.		
RR LH IN ABS SOL [C1124]	Circuit of rear LH IN ABS solenoid is open or shorted, or control line is open or shorted to power supply or ground.		
RR LH OUT ABS SOL [C1125]	Circuit of rear LH OUT ABS solenoid is open or shorted, or control line is open or shorted to power supply or ground.		
RR RH IN ABS SOL [C1126]	Circuit of rear RH IN ABS solenoid is open or shorted, or control line is open or shorted to power supply or ground.		
RR RH OUT ABS SOL [C1127]	Circuit of rear RH OUT ABS solenoid is open or shorted, or control line is open or shorted to power supply or ground.		

TROUBLE DIAGNOSIS

[ABS]

< SERVICE INFORMATION >

Self-diagnostic item	Malfunction detecting condition	Check system
MAIN RELAY [C1114]	ABS actuator relay or circuit malfunction.	BRC-28. "Actuator Motor, Motor Relay, and Circuit Inspection"
CAN COMM CIRCUIT [U1000]	<ul style="list-style-type: none"> CAN communication line is open or shorted. ABS actuator and electric unit (control unit) internal malfunction Battery voltage for ECM is suddenly interrupted for approximately 0.5 second or more. 	BRC-30. "CAN Communication System Inspection" (Note 2)

Note 1: If wheel sensor 2 for each wheel is indicated, check ABS actuator and electric unit (control unit) power supply voltage in addition to wheel sensor circuit check.

Note 2: If multiple malfunctions are detected including CAN communication line [U1000], perform diagnosis for CAN communication line first.

DATA MONITOR

Operation Procedure

- After turning OFF the ignition switch, connect CONSULT-III to the data link connector.
- Touch "ABS", "DATA MONITOR" in order on the CONSULT-III screen.
If "ABS" is not indicated, go to [GI-36. "CONSULT-III Data Link Connector \(DLC\) Circuit"](#).
- Return to the SELECT MONITOR ITEM screen, and touch "ECU INPUT SIGNALS", "MAIN SIGNALS" or "SELECTION FROM MENU". Refer to the following information.
- When "START" is touched, the data monitor screen is displayed.

Display Item List

Item (Unit)	Data monitor item selection			Remarks
	ECU INPUT SIGNALS	MAIN SIGNALS	SELECTION FROM MENU	
FR RH SENSOR (km/h, MPH)	×	×	×	Wheel speed calculated by front RH wheel sensor signal is displayed.
FR LH SENSOR (km/h, MPH)	×	×	×	Wheel speed calculated by front LH wheel sensor signal is displayed.
RR RH SENSOR (km/h, MPH)	×	×	×	Wheel speed calculated by rear RH wheel sensor signal is displayed.
RR LH SENSOR (km/h, MPH)	×	×	×	Wheel speed calculated by rear LH wheel sensor signal is displayed.
BATTERY VOLT (V)	×	×	×	Voltage supplied to ABS actuator and electric unit (control unit) is displayed.
STOP LAMP SW (ON/OFF)	×	×	×	Stop lamp switch (ON/OFF) status is displayed.
ABS WARN LAMP (ON/OFF)	—	×	×	ABS warning lamp (ON/OFF) status is displayed.
FR LH IN SOL (ON/OFF)	—	×	×	Front LH IN ABS solenoid (ON/OFF) status is displayed.
FR LH OUT SOL (ON/OFF)	—	×	×	Front LH OUT ABS solenoid (ON/OFF) status is displayed.
FR RH IN SOL (ON/OFF)	—	×	×	Front RH IN ABS solenoid (ON/OFF) status is displayed.
FR RH OUT SOL (ON/OFF)	—	×	×	Front RH OUT ABS solenoid (ON/OFF) status is displayed.
RR LH IN SOL (ON/OFF)	—	×	×	Rear LH IN ABS solenoid (ON/OFF) status is displayed.
RR LH OUT SOL (ON/OFF)	—	×	×	Rear LH OUT ABS solenoid (ON/OFF) status is displayed.

TROUBLE DIAGNOSIS

[ABS]

< SERVICE INFORMATION >

Item (Unit)	Data monitor item selection			Remarks
	ECU INPUT SIGNALS	MAIN SIGNALS	SELECTION FROM MENU	
RR RH IN SOL (ON/OFF)	-	×	×	Rear RH IN ABS solenoid (ON/OFF) status is displayed.
RR RH OUT SOL (ON/OFF)	-	×	×	Rear RH OUT ABS solenoid (ON/OFF) status is displayed.
MOTOR RELAY (ON/OFF)	-	×	×	ABS motor relay signal (ON/OFF) status is displayed.
ACTUATOR RLY (ON/OFF)	-	×	×	ABS actuator relay signal (ON/OFF) status is displayed.
ABS FAIL SIG (ON/OFF)	-	-	×	ABS fail signal (ON/OFF) status is displayed.
EBD FAIL SIG (ON/OFF)	-	-	×	EBD fail signal (ON/OFF) status is displayed.
EBD SIGNAL (ON/OFF)	-	-	×	EBD operation (ON/OFF) status is displayed.
ABS SIGNAL (ON/OFF)	-	-	×	ABS operation (ON/OFF) status is displayed.

×: Applicable

-: Not applicable

ACTIVE TEST

CAUTION:

- Do not perform active test while driving.
- Make sure to completely bleed air from the brake system.
- The ABS and brake warning lamps turn on during the active test.

Operation Procedure

1. Connect the CONSULT-III to the data link connector and start the engine.
2. Touch "ABS".
If "ABS" is not indicated, go to [GI-36. "CONSULT-III Data Link Connector \(DLC\) Circuit"](#).
3. Touch "ACTIVE TEST".
4. The SELECT TEST ITEM screen is displayed.
5. Touch necessary test item.
6. With the "MAIN SIGNALS" display selected, touch "START".
7. The Active Test screen will be displayed, so conduct the following test.

Solenoid Valve Operation Chart

TEST ITEM	CONDITION	JUDGEMENT		
FR RH SOL FR LH SOL RR RH SOL RR LH SOL	Ignition switch is turned ON.	Brake fluid pressure control operation		
			IN SOL	OUT SOL
		UP (Increase):	OFF	OFF
		KEEP (Hold):	ON	OFF
		DOWN (Decrease):	ON	ON

NOTE:

- If active test is performed with brake pedal depressed, pedal stroke may change. This is normal.
- "TEST IS STOPPED" is displayed approximately 10 seconds after operation starts.
- After "TEST IS STOPPED" is displayed, to perform test again, repeat Step 6.

ABS Motor

Touch "ON" and "OFF" on the screen. Check that ABS motor relay operates as shown in table below.

TROUBLE DIAGNOSIS

< SERVICE INFORMATION >

[ABS]

Operation	ON	OFF
ABS actuator relay	ON	ON
ABS motor relay	ON	OFF

NOTE:

- If active test is performed with brake pedal depressed, pedal stroke may change. This is normal.
- "TEST IS STOPPED" is displayed approximately 10 seconds after operation starts.

A

B

C

D

E

BRC

G

H

I

J

K

L

M

N

O

P

TROUBLE DIAGNOSIS FOR SELF-DIAGNOSTIC ITEMS

< SERVICE INFORMATION >

[ABS]

TROUBLE DIAGNOSIS FOR SELF-DIAGNOSTIC ITEMS

Wheel Sensor System

INFOID:000000005397040

INSPECTION PROCEDURE

1. CONNECTOR INSPECTION

Disconnect the ABS actuator and electric unit (control unit) connector E33 and wheel sensor of malfunctioning code.

Check the terminals for deformation, disconnection, looseness or damage.

OK or NG

OK >> GO TO 2.

NG >> Repair or replace as necessary.

2. CHECK WHEEL SENSOR OUTPUT SIGNAL

1. Connect ABS active wheel sensor tester (J-45741) to wheel sensor using appropriate adapter.

2. Turn on the ABS active wheel sensor tester power switch.

NOTE:

The green POWER indicator should illuminate. If the POWER indicator does not illuminate, replace the battery in the ABS active wheel sensor tester before proceeding.

3. Spin the wheel of the vehicle by hand and observe the red SENSOR indicator on the ABS active wheel sensor tester. The red SENSOR indicator should flash on and off to indicate an output signal.

NOTE:

If the red SENSOR indicator illuminates but does not flash, reverse the polarity of the tester leads and retest.

Does the ABS active wheel sensor tester detect a signal?

YES >> GO TO 3.

NO >> Replace the wheel sensor. Refer to [BRC-34. "Removal and Installation"](#).

3. CHECK TIRES

Check for inflation pressure, wear and size of each tire. Refer to [WT-28](#).

Are tire pressure and size correct and is tire wear within specifications?

YES >> GO TO 4.

NO >> Adjust tire pressure or replace tire(s).

4. CHECK WHEEL BEARINGS

Check wheel bearing axial end play. Refer to [FAX-6. "On-Vehicle Inspection and Service"](#) or [RAX-6. "On-Vehicle Inspection and Service"](#).

OK or NG

OK >> GO TO 5.

NG >> Repair or replace as necessary. Refer to [FAX-6. "Removal and Installation"](#) or [RAX-6. "Removal and Installation"](#).

5. CHECK WIRING HARNESS FOR SHORT CIRCUIT

1. Turn ignition switch OFF.

2. Disconnect ABS actuator and electric unit (control unit) connector and wheel sensor connector of malfunction code No.

3. Check continuity between wheel sensor harness connector terminals and ground.

Continuity should not exist.

OK or NG

OK >> GO TO 6.

NG >> Repair the circuit.

6. CHECK WIRING HARNESS FOR OPEN CIRCUIT

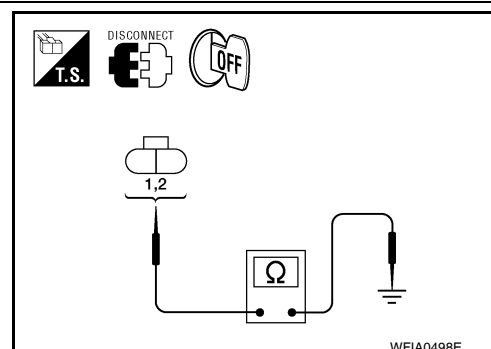

TROUBLE DIAGNOSIS FOR SELF-DIAGNOSTIC ITEMS

[ABS]

< SERVICE INFORMATION >

Check continuity between ABS actuator and electric unit (control unit) harness connector and wheel sensor harness connector.

Wheel sensor	ABS actuator and electric unit (control unit)		Wheel sensor		Continuity
	Connector	Terminals	Connector	Terminals	
Front LH	E33	5	E18	1	Yes
		16		2	
Front RH		10	E117	1	
		9		2	
Rear LH		17	B123	1	
		6		2	
Rear RH		19	B122	1	
		8		2	

OK or NG

- OK >> Replace the ABS actuator and electric unit (control unit). Refer to [BRC-37, "Removal and Installation"](#).
- NG >> Repair the circuit.

ABS Control Unit Inspection

INFOID:000000005397041

INSPECTION PROCEDURE

1. SELF-DIAGNOSIS RESULT CHECK

Check self-diagnosis results.

Self-diagnosis results
CONTROLLER FAILURE

Is the above displayed in the self-diagnosis display items?

- YES >> Replace ABS actuator and electric unit (control unit). Refer to [BRC-37, "Removal and Installation"](#).
- NO >> Inspection End.

Solenoid Valve System Inspection

INFOID:000000005397042

INSPECTION PROCEDURE

1. SELF-DIAGNOSIS RESULT CHECK

Check self-diagnosis results.

Self-diagnosis results
FR LH IN ABS SOL
FR LH OUT ABS SOL
FR RH IN ABS SOL
FR RH OUT ABS SOL
RR LH IN ABS SOL
RR LH OUT ABS SOL
RR RH IN ABS SOL
RR RH OUT ABS SOL

Is the above displayed in the self-diagnosis display items?

- YES >> GO TO 2.
- NO >> Inspection End.

TROUBLE DIAGNOSIS FOR SELF-DIAGNOSTIC ITEMS

[ABS]

< SERVICE INFORMATION >

2. CONNECTOR INSPECTION

1. Disconnect ABS actuator and electric unit (control unit) connector E33.
2. Check the terminals for deformation, disconnection, looseness or damage.

OK or NG

- OK >> GO TO 3.
 NG >> Repair or replace as necessary.

3. CHECKING SOLENOID POWER AND GROUND

1. Check voltage between ABS actuator and electric unit (control unit) harness connector E33 and body ground.

ABS actuator and electric unit (control unit) harness connector E33	Body ground	Measured value (Approx.)
3	—	12V

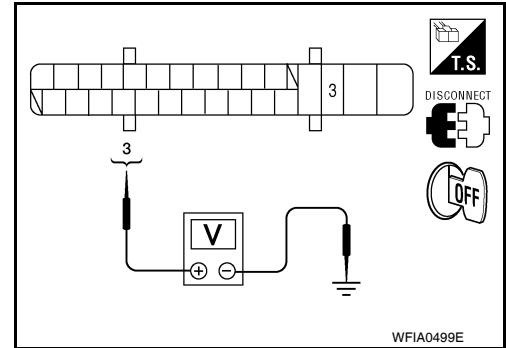

2. Check resistance between ABS actuator and electric unit (control unit) harness connector E33 and body ground.

ABS actuator and electric unit (control unit) harness connector E33	Body ground	Measured value (Approx.)
4	—	0Ω

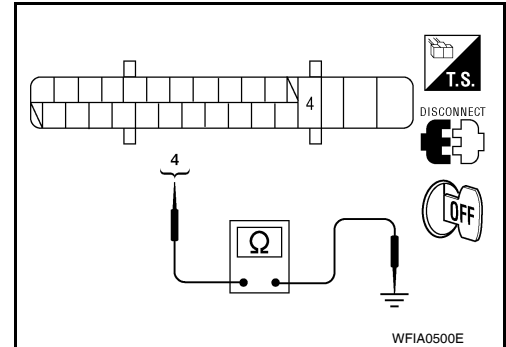

OK or NG

- OK >> Perform self-diagnosis again. If the same results appear, replace ABS actuator and electric unit (control unit). Refer to [BRC-37, "Removal and Installation"](#).
 NG >> Repair the circuit.

Actuator Motor, Motor Relay, and Circuit Inspection

INFOID:000000005397043

INSPECTION PROCEDURE

1. CHECKING SELF-DIAGNOSIS RESULTS

Check self-diagnosis results.

Self-diagnosis results
PUMP MOTOR
MAIN RELAY

Is the above displayed in the self-diagnosis display items?

- YES >> GO TO 2.
 NO >> Inspection End.

2. CONNECTOR INSPECTION

1. Disconnect ABS actuator and electric unit (control unit) connector E33.
2. Check the terminals for deformation, disconnection, looseness or damage.

OK or NG

- OK >> GO TO 3.
 NG >> Repair or replace as necessary.

3. CHECKING ABS MOTOR AND MOTOR RELAY POWER SYSTEM

TROUBLE DIAGNOSIS FOR SELF-DIAGNOSTIC ITEMS

[ABS]

< SERVICE INFORMATION >

1. Check voltage between ABS actuator and electric unit (control unit) harness connector E33 and ground.

ABS actuator and electric unit (control unit) harness connector E33	Body ground	Measured value (Approx.)
2	—	12V

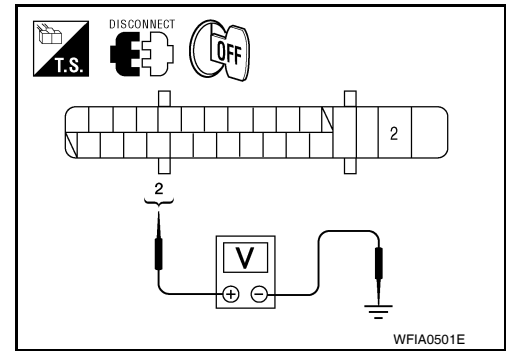

2. Check resistance between ABS actuator and electric unit (control unit) connector E33 and ground.

ABS actuator and electric unit (control unit) harness connector E33	Body ground	Measured value (Approx.)
1	—	0Ω

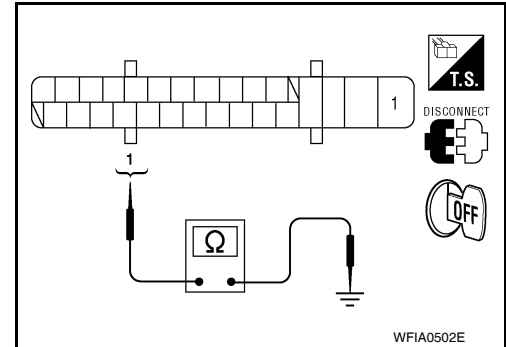

OK or NG

- OK >> Perform self-diagnosis again. If the same results appear, replace ABS actuator and electric unit (control unit). Refer to [BRC-37, "Removal and Installation"](#).
- NG >> Repair the circuit.

ABS Control Unit Power and Ground Systems Inspection

INFOID:000000005397044

INSPECTION PROCEDURE

1.SELF-DIAGNOSIS RESULT CHECK

Check self-diagnosis results.

Self-diagnosis results
BATTERY VOLTAGE

Is the above displayed in the self-diagnosis display items?

- YES >> GO TO 2.
 NO >> Inspection End.

2.CONNECTOR INSPECTION

1. Disconnect the ABS actuator and electric unit (control unit) connector E33.
2. Check the terminals for deformation, disconnection, looseness or damage.

OK or NG

- OK >> GO TO 3.
 NG >> Repair or replace as necessary.

3.ABS CONTROL UNIT POWER AND GROUND CIRCUIT INSPECTION

Measure the voltage and continuity between the ABS actuator and electric unit (control unit) harness connector E33 and ground.

Signal name	ABS actuator and electric unit (control unit) harness connector E33	Body ground	Measured value
Power supply	2	—	Battery voltage (Approx. 12V)
	3		

TROUBLE DIAGNOSIS FOR SELF-DIAGNOSTIC ITEMS

< SERVICE INFORMATION >

[ABS]

Ground	1	—	Continuity should exist.
	4		

OK or NG

- OK >> Check the battery for loose terminals, low voltage, etc. Repair as necessary.
- NG >> Repair the circuit.

CAN Communication System Inspection

INFOID:000000005397045

INSPECTION PROCEDURE

1. CHECK CONNECTOR

1. Turn ignition switch OFF, disconnect the ABS actuator and electric unit (control unit) connector and check the terminals for deformation, disconnection, looseness, and so on. If there is a malfunction, repair or replace the terminal.
2. Reconnect connector to perform self-diagnosis.

Is "CAN COMM CIRCUIT" displayed in self-diagnosis display items?

- YES >> Print out the self-diagnostic results, and refer to [LAN-17, "Trouble Diagnosis Flow Chart"](#).
- NO >> Connector terminal is loose, damaged, open, or shorted.

TROUBLE DIAGNOSES FOR SYMPTOMS

< SERVICE INFORMATION >

[ABS]

TROUBLE DIAGNOSES FOR SYMPTOMS

ABS Works Frequently

INFOID:000000005397046

1. CHECK WARNING LAMP ACTIVATION

Make sure warning lamp remains off while driving.

OK or NG

OK >> GO TO 2.

NG >> Carry out self-diagnosis. Refer to [BRC-20, "CONSULT-III Function \(ABS\)"](#).

2. CHECK WHEEL SENSORS

Check the following.

- Wheel sensor mounting for looseness
- Wheel sensors for physical damage
- Wheel sensor connectors for terminal damage or loose connections
- Sensor rotor and mount for physical damage

OK or NG

OK >> GO TO 3.

NG >> Repair or replace as necessary.

3. CHECK WHEEL BEARINGS

Check wheel bearing axial end play. Refer to [FAX-6, "On-Vehicle Inspection and Service"](#) or [RAX-6, "On-Vehicle Inspection and Service"](#).

OK or NG

OK >> GO TO 4.

NG >> Repair as necessary.

4. CHECK BRAKE FLUID PRESSURE

Check brake fluid pressure distribution.

Refer to [BRC-18, "Basic Inspection"](#).

Is brake fluid pressure distribution normal?

YES >> Inspection End.

NO >> Perform Basic Inspection. Refer to [BRC-18, "Basic Inspection"](#).

Unexpected Pedal Action

INFOID:000000005397047

1. CHECK WARNING LAMP ACTIVATION

Make sure warning lamp remains off while driving.

OK or NG

OK >> GO TO 2.

NG >> Carry out self-diagnosis. Refer to [BRC-20, "CONSULT-III Function \(ABS\)"](#).

2. CHECK BRAKE PEDAL STROKE

Check brake pedal stroke.

Is brake pedal stroke excessive?

YES >> Perform Basic Inspection. Refer to [BRC-18, "Basic Inspection"](#).

NO >> GO TO 3.

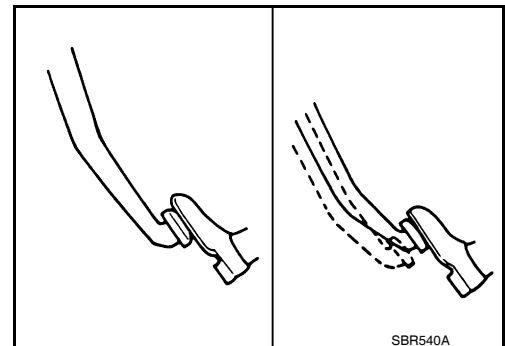

3. CHECK CONNECTOR AND BRAKING PERFORMANCE

1. Disable ABS by disconnecting ABS actuator and electric unit (control unit) connector.

TROUBLE DIAGNOSES FOR SYMPTOMS

[ABS]

< SERVICE INFORMATION >

2. Drive vehicle and check brake operation.

NOTE:

- Stopping distance may be longer than vehicles without ABS when road condition is slippery.
- Driving the vehicle with the ABS actuator and electric unit (control unit) disconnected may induce DTCs in electrical control units using CAN communication. After the inspection, clear all DTCs. Refer to [LAN-7. "System Description"](#).

OK or NG

OK >> GO TO 4.

NG >> Perform Basic Inspection. Refer to [BRC-18. "Basic Inspection"](#).

4. CHECK WHEEL SENSORS

Check the following.

- Wheel sensor mounting for looseness
- Wheel sensors for physical damage
- Wheel sensor connectors for terminal damage or loose connections
- Sensor rotor and mount for physical damage

OK or NG

OK >> Check ABS actuator and electric unit (control unit) connector terminals for deformation, disconnection, looseness or damage. Reconnect ABS actuator and electric unit (control unit) harness connector. Then retest.

NG >> Repair or replace as necessary.

Long Stopping Distance

INFOID:000000005397048

1. CHECK BASE BRAKING SYSTEM PERFORMANCE

1. Disable ABS by disconnecting ABS actuator and electric unit (control unit) connector.

2. Drive vehicle and check brake operation.

NOTE:

- Stopping distance may be longer than vehicles without ABS when road condition is slippery.
- Driving the vehicle with the ABS actuator and electric unit (control unit) disconnected may induce DTCs in electrical control units using CAN communication. After the inspection, clear all DTCs. Refer to [LAN-7. "System Description"](#).

OK or NG

OK >> Go to [BRC-31. "ABS Works Frequently"](#).

NG >> Perform Basic Inspection. Refer to [BRC-18. "Basic Inspection"](#).

ABS Does Not Work

INFOID:000000005397049

CAUTION:

The ABS does not operate when the vehicle speed is 10 km/h (6 MPH) or less.

1. CHECK WARNING LAMP ACTIVATION

Turn ignition switch ON and check for warning lamp activation.

- Warning lamp should activate for approximately 2 seconds after turning the ignition switch ON.

OK or NG

OK >> Carry out self-diagnosis. Refer to [BRC-20. "CONSULT-III Function \(ABS\)"](#).

NG >> Go to [BRC-18. "Basic Inspection"](#).

Pedal Vibration or ABS Operation Noise

INFOID:000000005397050

NOTE:

During ABS activation, pedal vibration may be felt and a noise may be heard. This is normal and does not indicate a malfunction.

1. CHECK SYMPTOM

1. Apply brake.

2. Start engine.

Does the symptom occur only when engine is started?

YES >> Carry out self-diagnosis. Refer to [BRC-20. "CONSULT-III Function \(ABS\)"](#).

TROUBLE DIAGNOSES FOR SYMPTOMS

< SERVICE INFORMATION >

[ABS]

NO >> GO TO 2.

2.RECHECK SYMPTOM

Does the symptom occur only when electrical equipment switches (such as headlamps) are turned on?

YES >> Check for radio, antenna or related wiring that is routed too close to the ABS actuator and electric unit (control unit) and reroute as necessary.

NO >> Go to [BRC-31, "ABS Works Frequently"](#).

A

B

C

D

E

BRC

G

H

I

J

K

L

M

N

O

P

WHEEL SENSORS

< SERVICE INFORMATION >

[ABS]

WHEEL SENSORS

Removal and Installation

INFOID:000000005397051

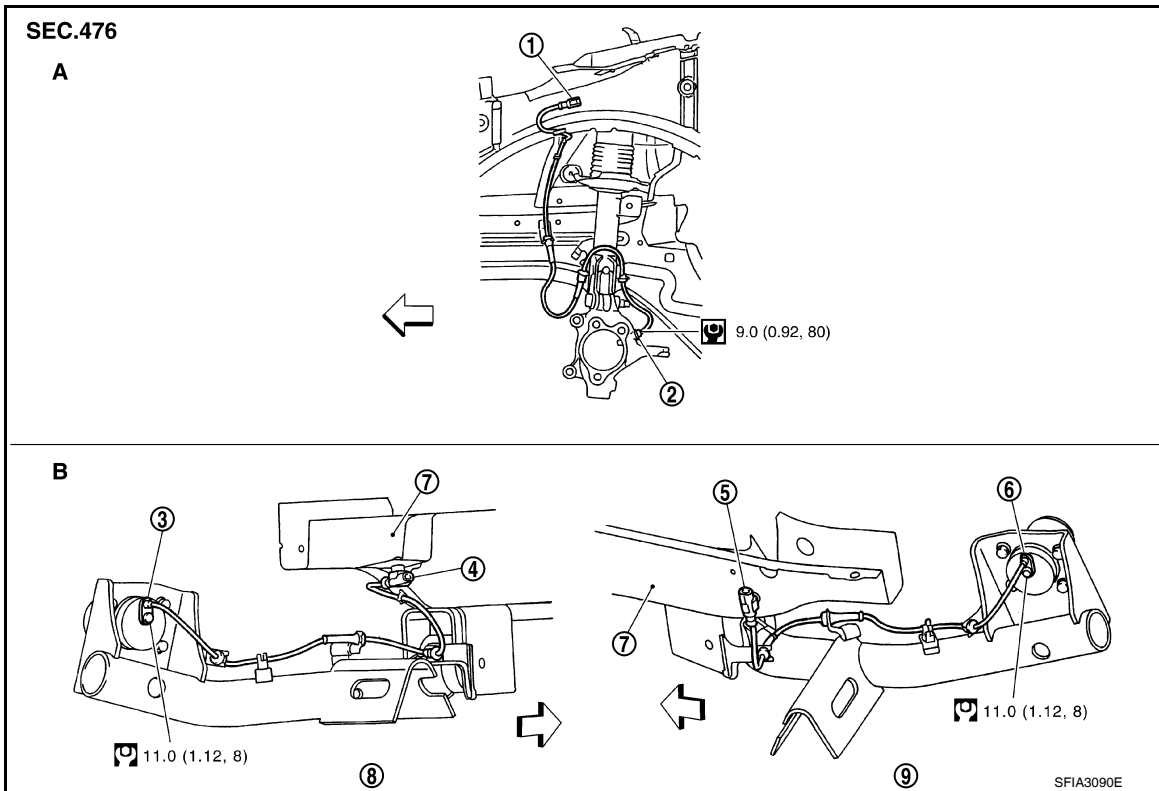

- | | | |
|-------------------------------------|---------------------------|--------------------------------------|
| A. Front | B. Rear | 1. Front wheel sensor connector (LH) |
| 2. Front wheel sensor (LH) | 3. Rear wheel sensor (LH) | 4. Rear wheel sensor connector (LH) |
| 5. Rear wheel sensor connector (RH) | 6. Rear wheel sensor (RH) | 7. Side member |
| 8. LH side | 9. RH side | ⇐ Front |

NOTE:

The top portion of the figure (front side) shows the view from LH side of the vehicle. The RH side is the mirror image of the LH side.

FRONT WHEEL SENSOR

Removal

CAUTION:

- As much as possible, avoid rotating wheel sensor when removing it. Pull wheel sensors out without pulling on sensor harness.
- Take care to avoid damaging wheel sensor edges or rotor teeth. Remove wheel sensor first before removing front or rear wheel hub. This is to avoid damage to wheel sensor wiring and loss of sensor function.

1. Remove the front wheel and tire. Refer to [WT-7, "Adjustment"](#).
2. Remove the front fender protector. Refer to [EI-24, "Removal and Installation"](#).
3. Disconnect the front wheel sensor connector.
4. Remove the front wheel sensor.

Installation

Installation is in the reverse order of removal.

CAUTION:

- When installing, make sure there is no foreign material such as iron chips on and in the mounting hole of the wheel sensor. Make sure no foreign material has been caught in the sensor rotor. Remove any foreign material and clean the mount.

WHEEL SENSORS

[ABS]

< SERVICE INFORMATION >

- When installing front wheel sensor, press rubber grommets of strut bracket and body all the way in until they get locked, and be careful not to apply a twist to harness. Harness should not be twisted after installation. (Install it with harness paint mark on body side grommet facing front of vehicle, and the strut side grommet facing outside of vehicle.)

A

REAR WHEEL SENSOR

B

Removal

CAUTION:

- As much as possible, avoid rotating wheel sensor when removing it. Pull wheel sensors out without pulling on sensor harness.
- Take care to avoid damaging wheel sensor edges or rotor teeth. Remove wheel sensor first before removing front or rear wheel hub. This is to avoid damage to wheel sensor wiring and loss of sensor function.

C

1. Disconnect the rear wheel sensor connector.
2. Remove the rear wheel sensor.

D

E

Installation

Installation is in the reverse order of removal.

CAUTION:

- When installing, make sure there is no foreign material such as iron chips on and in the mounting hole of the wheel sensor. Make sure no foreign material has been caught in the sensor rotor. Remove any foreign material and clean the mount.
- When installing rear wheel sensor, press rubber grommets of suspension arm bracket and harness of side member all the way in until they get locked, and be careful not to apply a twist to harness. Harness should not be twisted after installation. (Aim the paint mark upward of vehicle.)

BRC

G

H

I

J

K

L

M

N

O

P

SENSOR ROTOR

< SERVICE INFORMATION >

[ABS]

SENSOR ROTOR

Removal and Installation

INFOID:000000005397052

The front and rear sensor rotors are part of the hub and bearing assembly and cannot be removed separately. To replace the front or rear sensor rotors, the hub and bearing assembly must be replaced. Refer to [FAX-6, "Removal and Installation"](#) (front axle), [RAX-6, "Removal and Installation"](#) (rear axle).

ACTUATOR AND ELECTRIC UNIT (ASSEMBLY)

< SERVICE INFORMATION >

[ABS]

ACTUATOR AND ELECTRIC UNIT (ASSEMBLY)

Removal and Installation

INFOID:000000005397053

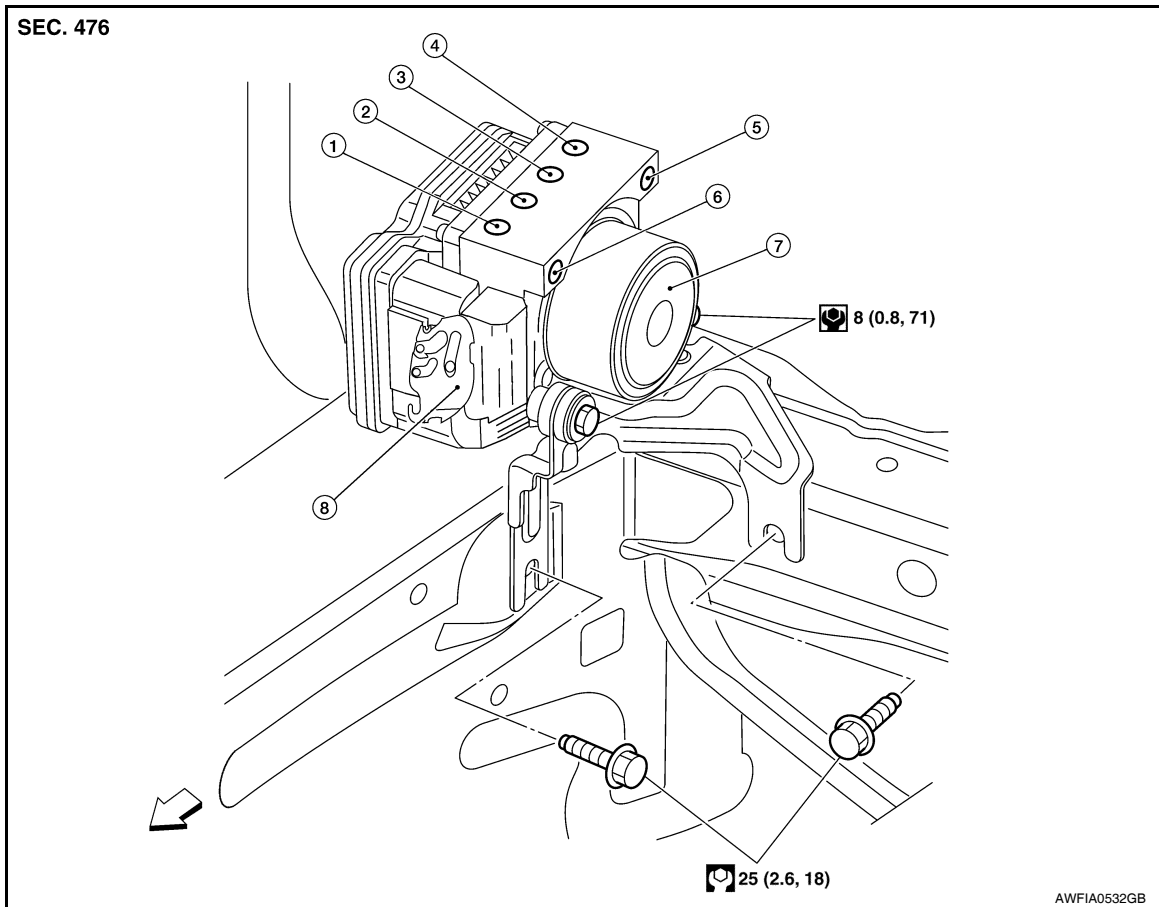

- | | | |
|--|--------------------------------------|--|
| 1. To front right caliper | 2. To rear left wheel cylinder | 3. To rear right wheel cylinder |
| 4. To front left caliper | 5. From master cylinder primary side | 6. From master cylinder secondary side |
| 7. ABS actuator and electric unit (control unit) | 8. Harness connector | ⇐ Front |

CAUTION:

- Before servicing, disconnect battery negative terminal.
- To remove brake tube, use flare nut wrench to prevent flare nuts and brake tube from being damaged. To install, use flare nut torque wrench, tighten flare nut to the specified torque. Refer to [BR-11, "Hydraulic Circuit"](#).
- Do not apply excessive impact to ABS actuator and electric unit (control unit), such as dropping it.
- Do not remove and install actuator by holding harness.
- After work is completed, bleed the air from the brake hydraulic system. Refer to [BR-9, "Bleeding Brake System"](#).

REMOVAL

1. Disconnect the battery negative terminal.
2. Remove the cowl top. Refer to [EI-22, "Removal and Installation"](#).
3. Disconnect ABS actuator and electric unit (control unit) connector.
4. Loosen brake tube flare nuts, then remove brake tubes from ABS actuator and electric unit (control unit).
5. Remove brake booster hose from engine. Refer to [BR-23, "Removal and Installation"](#).
6. Remove ABS actuator and electric unit (control unit) bracket bolts.
7. Remove ABS actuator and electric unit (control unit).

ACTUATOR AND ELECTRIC UNIT (ASSEMBLY)

[ABS]

< SERVICE INFORMATION >

INSTALLATION

Installation is in the reverse order of removal.

- Bleed the brake system. Refer to [BR-9, "Bleeding Brake System"](#).

CAUTION:

After installing harness connector in the ABS actuator and electric unit (control unit), make sure the connector is securely locked.

SERVICE INFORMATION

PRECAUTIONS

Precaution for Supplemental Restraint System (SRS) "AIR BAG" and "SEAT BELT PRE-TENSIONER"

INFOID:000000005612135

The Supplemental Restraint System such as "AIR BAG" and "SEAT BELT PRE-TENSIONER", used along with a front seat belt, helps to reduce the risk or severity of injury to the driver and front passenger for certain types of collision. This system includes seat belt switch inputs and dual stage front air bag modules. The SRS system uses the seat belt switches to determine the front air bag deployment, and may only deploy one front air bag, depending on the severity of a collision and whether the front occupants are belted or unbelted. Information necessary to service the system safely is included in the SRS and SB section of this Service Manual.

WARNING:

- To avoid rendering the SRS inoperative, which could increase the risk of personal injury or death in the event of a collision which would result in air bag inflation, all maintenance must be performed by an authorized NISSAN/INFINITI dealer.
- Improper maintenance, including incorrect removal and installation of the SRS can lead to personal injury caused by unintentional activation of the system. For removal of Spiral Cable and Air Bag Module, see the SRS section.
- Do not use electrical test equipment on any circuit related to the SRS unless instructed to in this Service Manual. SRS wiring harnesses can be identified by yellow and/or orange harnesses or harness connectors.

PRECAUTIONS WHEN USING POWER TOOLS (AIR OR ELECTRIC) AND HAMMERS

WARNING:

- When working near the Airbag Diagnosis Sensor Unit or other Airbag System sensors with the Ignition ON or engine running, DO NOT use air or electric power tools or strike near the sensor(s) with a hammer. Heavy vibration could activate the sensor(s) and deploy the air bag(s), possibly causing serious injury.
- When using air or electric power tools or hammers, always switch the Ignition OFF, disconnect the battery, and wait at least 3 minutes before performing any service.

Precaution Necessary for Steering Wheel Rotation After Battery Disconnect

INFOID:000000005976825

NOTE:

- This Procedure is applied only to models with Intelligent Key system and NATS (NISSAN ANTI-THEFT SYSTEM).
- Remove and install all control units after disconnecting both battery cables with the ignition knob in the "LOCK" position.
- Always use CONSULT-III to perform self-diagnosis as a part of each function inspection after finishing work. If DTC is detected, perform trouble diagnosis according to self-diagnostic results.

For models equipped with the Intelligent Key system and NATS, an electrically controlled steering lock mechanism is adopted on the key cylinder.

For this reason, if the battery is disconnected or if the battery is discharged, the steering wheel will lock and steering wheel rotation will become impossible.

If steering wheel rotation is required when battery power is interrupted, follow the procedure below before starting the repair operation.

OPERATION PROCEDURE

1. Connect both battery cables.

NOTE:

Supply power using jumper cables if battery is discharged.

2. Use the Intelligent Key or mechanical key to turn the ignition switch to the "ACC" position. At this time, the steering lock will be released.
3. Disconnect both battery cables. The steering lock will remain released and the steering wheel can be rotated.
4. Perform the necessary repair operation.

A
B
C
D
E
BRC
G
H
I
J
K
L
M
N
O
P

PRECAUTIONS

< SERVICE INFORMATION >

[VDC/TCS/ABS]

- When the repair work is completed, return the ignition switch to the "LOCK" position before connecting the battery cables. (At this time, the steering lock mechanism will engage.)
- Perform a self-diagnosis check of all control units using CONSULT-III.

Precaution for Brake System

INFOID:000000005612137

CAUTION:

- Refer to [MA-14, "Fluids and Lubricants"](#) for recommended brake fluid.
- Never reuse drained brake fluid.
- Be careful not to splash brake fluid on painted areas; it may cause paint damage. If brake fluid is splashed on painted areas, wash it away with water immediately.
- To clean or wash all parts of master cylinder and disc brake caliper, use clean brake fluid.
- Never use mineral oils such as gasoline or kerosene. They will ruin rubber parts of the hydraulic system.
- Use flare nut wrench when removing and installing brake tube.
- If a brake fluid leak is found, the part must be disassembled without fail. Then it has to be replaced with a new one if a defect exists.
- Turn the ignition switch OFF and remove the connector of the ABS actuator and electric unit (control unit) or the battery terminal before performing the work.
- Always torque brake lines when installing.
- Burnish the brake contact surfaces after refinishing or replacing rotors, after replacing pads, or if a soft pedal occurs at very low mileage.
Refer to [BR-34, "Brake Burnishing Procedure"](#).

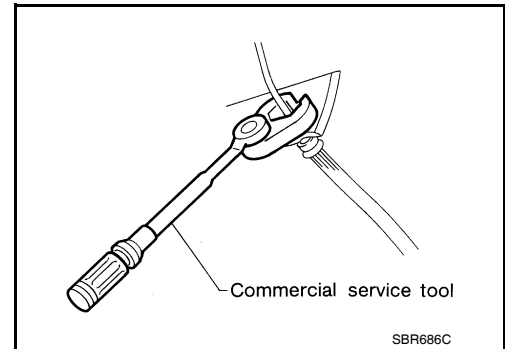

WARNING:

- Clean brake pads and shoes with a waste cloth, then wipe with a dust collector.

Precaution for Brake Control

INFOID:000000005612138

- During ABS operation, the brake pedal may vibrate lightly and a mechanical noise may be heard. This is normal.
- Just after starting vehicle, the brake pedal may vibrate or a motor operating noise may be heard from engine compartment. This is a normal status of operation check.
- Stopping distance may be longer than that of vehicles without ABS when vehicle drives on rough, gravel, or snow-covered (fresh, deep snow) roads.
- When an error is indicated by ABS or another warning lamp, collect all necessary information from customer (what symptoms are present under what conditions) and check for simple causes before starting diagnosis. Besides electrical system inspection, check booster operation, brake fluid level, and fluid leaks.
- If incorrect tire sizes or types are installed on the vehicle or brake pads are not Genuine NISSAN parts, stopping distance or steering stability may deteriorate.
- If there is a radio, antenna or related wiring near control module, ABS function may have a malfunction or error.
- If aftermarket parts (car stereo, CD player, etc.) have been installed, check for incidents such as harness pinches, open circuits or improper wiring.
- If the following components are replaced with non-genuine components or modified, the VDC OFF indicator lamp and SLIP indicator lamp may turn on or the VDC system may not operate properly. Components related to suspension (shock absorbers, struts, springs, bushings, etc.), tires, wheels (exclude specified size), components related to brake system (pads, rotors, calipers, etc.), components related to engine (muffler, ECM, etc.), components related to body reinforcement (roll bar, tower bar, etc.).
- Driving with broken or excessively worn suspension components, tires or brake system components may cause the VDC OFF indicator lamp and the SLIP indicator lamp to turn on, and the VDC system may not operate properly.
- When the TCS or VDC is activated by sudden acceleration or sudden turn, some noise may occur. The noise is a result of the normal operation of the TCS and VDC.
- When driving on roads which have extreme slopes (such as mountainous roads) or high banks (such as sharp curves on a freeway), the VDC may not operate normally, or the VDC warning lamp and the SLIP indicator lamp may turn on. This is not a problem if normal operation can be resumed after restarting the engine.

PRECAUTIONS

< SERVICE INFORMATION >

[VDC/TCS/ABS]

- Sudden turns (such as spin turns, acceleration turns), drifting, etc. with VDC turned off may cause the yaw rate/side/decel G sensor to indicate a problem. This is not a problem if normal operation can be resumed after restarting the engine.

Precaution for CAN System

INFOID:000000005612139

- Do not apply voltage of 7.0V or higher to terminal to be measured.
- Maximum open terminal voltage of tester in use must be less than 7.0V.
- Before checking harnesses, turn ignition switch OFF and disconnect battery negative cable.
- Area to be repaired must be soldered and wrapped with tape. Make sure that fraying of twisted wire is within 110 mm (4.33 in).

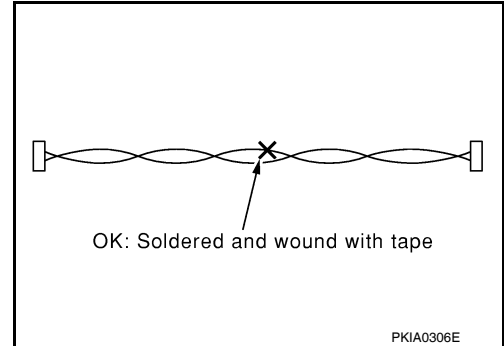

- Do not make a bypass connection to repaired area. (If the circuit is bypassed, characteristics of twisted wire will be lost.)

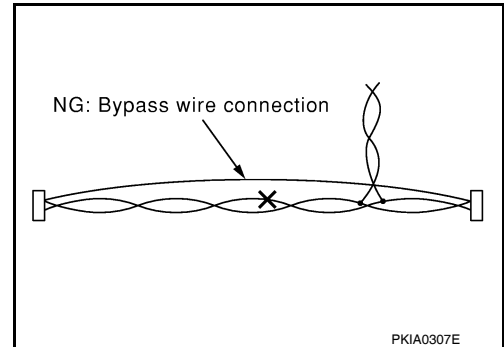

A
B
C
D
E
BRC
G
H
I
J
K
L
M
N
O
P

PREPARATION

< SERVICE INFORMATION >

[VDC/TCS/ABS]

PREPARATION

Special Service Tool

INFOID:000000005612140

The actual shapes of Kent-Moore tools may differ from those of special service tools illustrated here.

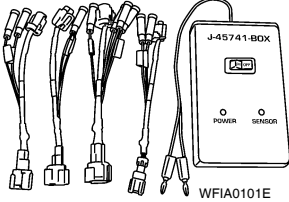
Tool number (Kent-Moore No.) Tool name	Description
(J-45741) ABS active wheel sensor tester	Checking operation of ABS active wheel sensor
 <p style="text-align: center;"><small>WFI A0101E</small></p>	

Commercial Service Tool

INFOID:000000005612141

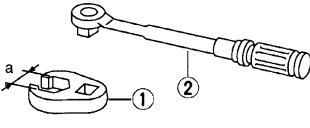
Tool name	Description
1. Flare nut crowfoot 2. Torque wrench	Removing and installing brake piping a: 10mm (0.39 in)/12mm (0.47 in)
 <p style="text-align: center;"><small>S-NT360</small></p>	

SYSTEM DESCRIPTION

System Component

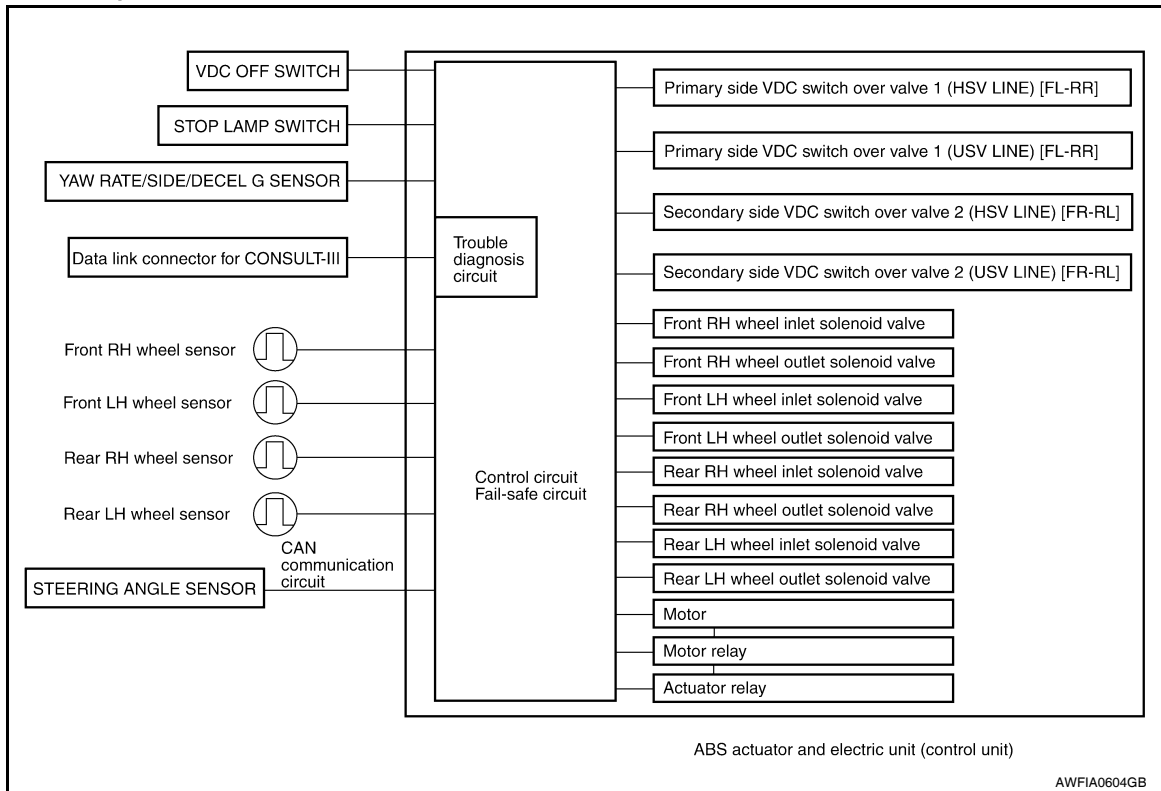

A
B
C
D
E
G
H
I

BRC

ABS Function

INFOID:000000005612143

- The Anti-Lock Brake System detects wheel revolution while braking and improves handling stability during sudden braking by electrically preventing wheel lockup. Maneuverability is also improved for avoiding obstacles.
- If the electrical system malfunctions, the Fail-Safe function is activated, the ABS becomes inoperative and the ABS warning lamp turns on.
- The electrical system can be diagnosed using CONSULT-III.
- During ABS operation, the brake pedal may vibrate lightly and a mechanical noise may be heard. This is normal.
- Just after starting the vehicle, the brake pedal may vibrate or a motor operating noise may be heard from engine compartment. This is a normal status of operation check.
- Stopping distance may be longer than that of vehicles without ABS when vehicle drives on rough, gravel, or snow-covered (fresh, deep snow) roads.

J
K
L
M

EBD Function

INFOID:000000005612144

- Electronic Brake Distribution is a function that detects subtle slippages between the front and rear wheels during braking, and it improves handling stability by electronically controlling the brake fluid pressure which results in reduced rear wheel slippage.
- If the electrical system malfunctions, the Fail-Safe function is activated, the EBD and ABS become inoperative, and the ABS warning lamp and BRAKE warning lamp are turned on.
- The electrical system can be diagnosed using CONSULT-III.
- During EBD operation, the brake pedal may vibrate lightly and a mechanical noise may be heard. This is normal.
- Just after starting the vehicle, the brake pedal may vibrate or a motor operating noise may be heard from engine compartment. This is a normal status of operation check.
- Stopping distance may be longer than that of vehicles without EBD when vehicle drives on rough, gravel, or snow-covered (fresh, deep snow) roads.

N
O
P

SYSTEM DESCRIPTION

< SERVICE INFORMATION >

[VDC/TCS/ABS]

TCS Function

INFOID:000000005612145

- Spinning of the drive wheels is detected by the ABS/TCS/VDC control unit using inputs from the wheel speed sensors. If wheel spin occurs, the drive wheel right and left brake fluid pressure control and engine fuel cut are conducted while the throttle value is restricted to reduce the engine torque and decrease the amount of wheel spin. In addition, the throttle opening is controlled to achieve the optimum engine torque.
- Depending on road condition, the vehicle may have a sluggish feel. This is normal, because optimum traction has the highest priority during TCS operation.
- TCS may be activated during sudden vehicle acceleration, wide open throttle acceleration, sudden transmission shifts or when the vehicle is driven on a road with a varying surface friction coefficient.
- The SLIP indicator lamp flashes to inform the driver of TCS operation.

VDC Function

INFOID:000000005612146

- In addition to the ABS/TCS function, the driver steering amount and brake operation amount are detected from the steering angle sensor, and the vehicle's driving status (amount of under steering/over steering) is determined using inputs from the yaw rate/side/decel G sensor, wheel speed sensors, etc. and this information is used to improve vehicle stability by controlling the braking and engine torque application to the wheels.
- The SLIP indicator lamp flashes to inform the driver of VDC operation.
- During VDC operation, the vehicle body and brake pedal may vibrate lightly and a mechanical noise may be heard. This is normal.
- The ABS warning lamp, VDC OFF indicator lamp and SLIP indicator lamp may turn on when the vehicle is subject to strong shaking or large vibration, such as when the vehicle is on a turn table or a ship while the engine is running or steep slope. In this case, restart the engine on a normal road and if the ABS warning lamp, VDC OFF indicator lamp and SLIP indicator lamp turn off, there is no problem.

Wheel Sensors

INFOID:000000005612147

The front sensor units consist of a gear-shaped sensor rotor and a sensor element. The element contains a magnet around which a coil is wound. The front wheel sensors are installed on the front of the wheel knuckles. As the wheel rotates, the sensor generates a square-wave signal. The frequency increases as the wheel speed increases.

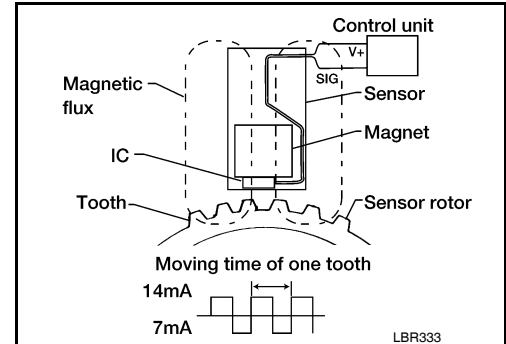

The rear sensor units consist of wheel hubs with a series of internal magnets and a sensor element. The rear wheel sensors are installed on the inner side of the wheel knuckles. As the wheel rotates, the sensor generates a square-wave signal. The frequency increases as the wheel speed increases.

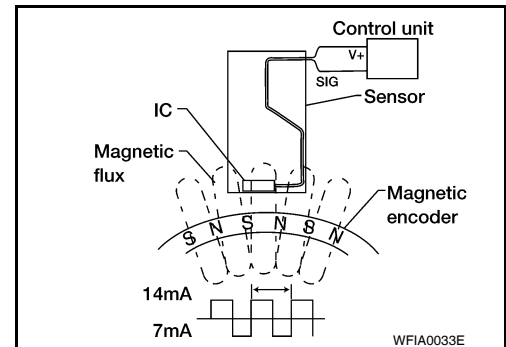

Fail-Safe Function

INFOID:000000005612148

ABS/EBD SYSTEM

In case of an electrical malfunction with the ABS, the ABS warning lamp, VDC OFF indicator lamp and SLIP indicator lamp will turn on. In case of an electrical malfunction with the EBD system, the BRAKE warning lamp, ABS warning lamp, VDC OFF indicator lamp and SLIP indicator lamp will turn on.

SYSTEM DESCRIPTION

< SERVICE INFORMATION >

[VDC/TCS/ABS]

The system will revert to one of the following conditions of the Fail-Safe function.

1. For ABS malfunction, only the EBD is operative and the condition of the vehicle is the same condition of vehicles without ABS/TCS/VDC system.
2. For EBD malfunction, the EBD and ABS become inoperative, and the condition of the vehicle is the same as the condition of vehicles without ABS/TCS/VDC or EBD system.

VDC/TCS SYSTEM

In case of TCS/VDC system malfunction, the VDC OFF indicator lamp and SLIP indicator lamp are turned on and the condition of the vehicle is the same as the condition of vehicles without TCS/VDC system. In case of an electrical malfunction with the TCS/VDC system, the ABS control continues to operate normally without TCS/VDC control.

CAUTION:

If the Fail-Safe function is activated, perform the Self Diagnosis for ABS/TCS/VDC system.

Hydraulic Circuit Diagram

INFOID:000000005612149

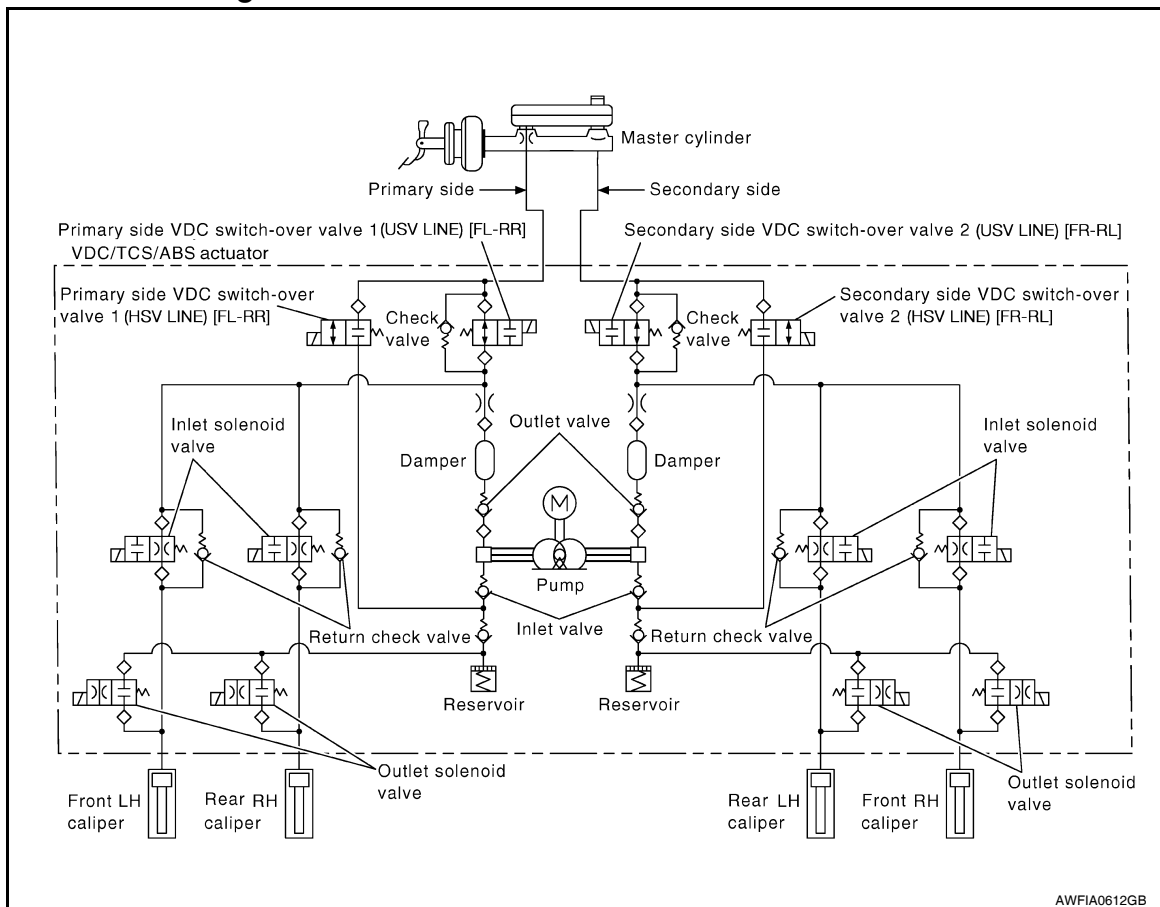

CAN COMMUNICATION

System Description

INFOID:000000005612150

Refer to [LAN-7. "System Description"](#).

TROUBLE DIAGNOSIS

How to Perform Trouble Diagnosis for Quick and Accurate Repair

INFOID:000000005612151

INTRODUCTION

The ABS/TCS/VDC system has an electronic control unit to control major functions. The control unit accepts input signals from sensors and controls actuator operation. It is also important to check for conventional malfunctions such as air leaks in the booster or lines, lack of brake fluid, or other malfunctions with the brake system.

It is much more difficult to diagnose a malfunction that occurs intermittently rather than continuously. Most intermittent malfunctions are caused by poor electrical connections or wiring. In this case, careful checking of suspicious circuits may help prevent the replacement of good parts.

A visual check only may not find the cause of the malfunction, so a road test should be performed.

Before undertaking actual checks, take just a few minutes to talk with a customer who approaches with an ABS/TCS/VDC complaint. The customer is a very good source of information, especially for intermittent malfunctions. Through the talks with the customer, find out what symptoms are present and under what conditions they occur. Start your diagnosis by looking for "conventional" malfunctions first. This is one of the best ways to troubleshoot brake malfunctions on an ABS/TCS/VDC equipped vehicle. Also check related Service Bulletins for information.

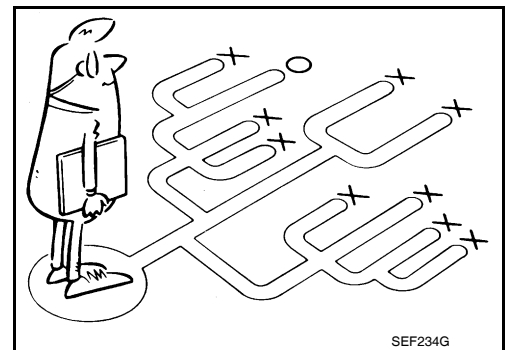
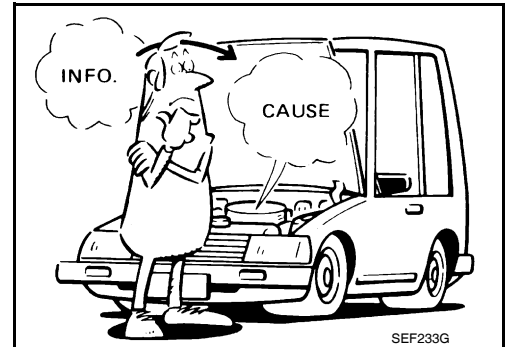

A
B
C
D
E
BRC
G
H
I
J
K
L
M
N
O
P

TROUBLE DIAGNOSIS

< SERVICE INFORMATION >

[VDC/TCS/ABS]

WORK FLOW

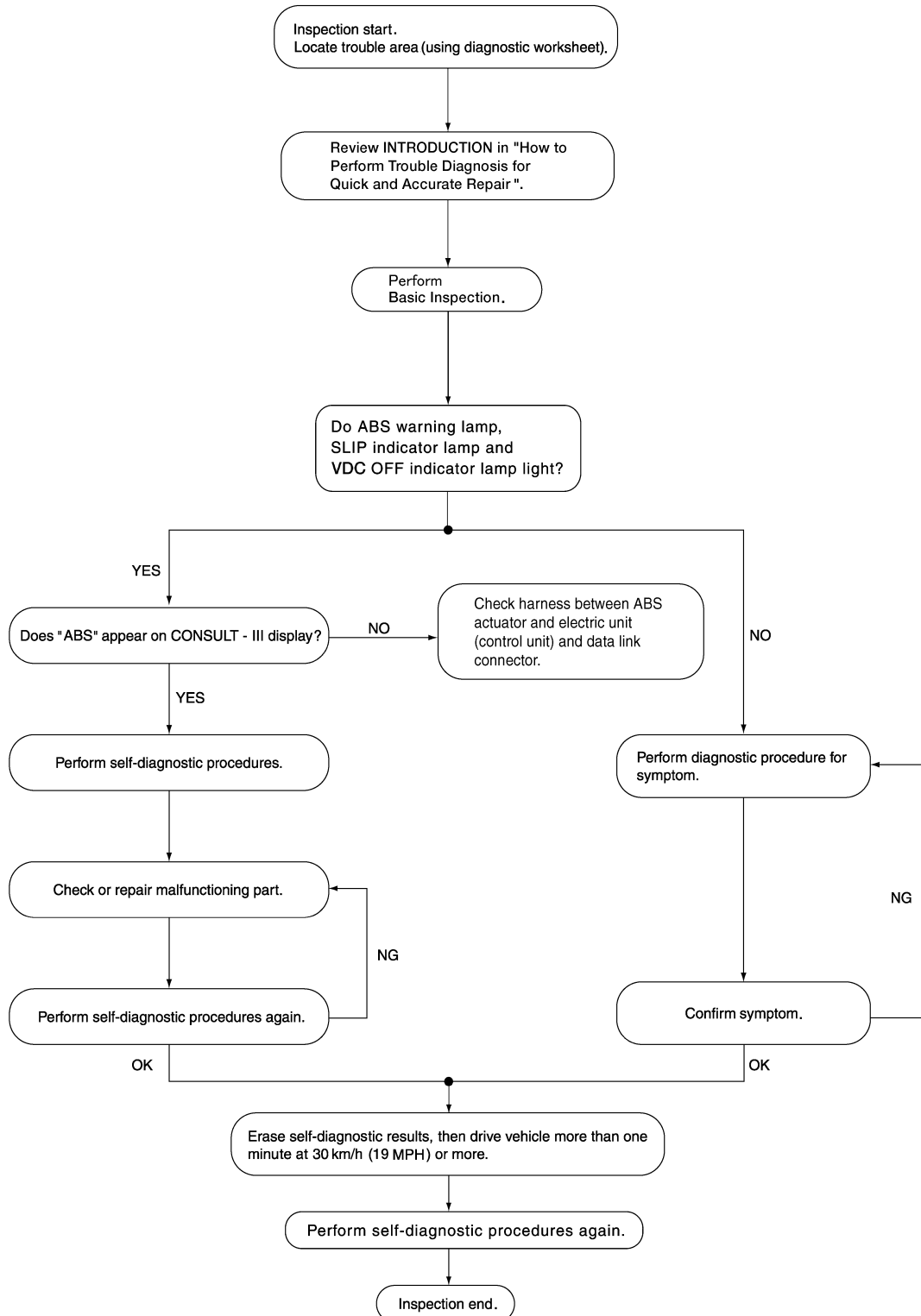

ALFIA0011GB

CLARIFY CONCERN

TROUBLE DIAGNOSIS

< SERVICE INFORMATION >

[VDC/TCS/ABS]

- A customer's description of a vehicle concern may vary depending on the individual. It is important to clarify the customer's concern.
- Ask the customer about what symptoms are present under what conditions. Use this information to reproduce the symptom while driving.
- It is also important to use the diagnosis sheet to understand what type of trouble the customer is having.

KEY POINTS

WHAT Vehicle model
WHEN Date, Frequencies
WHERE Road conditions
HOW Operating conditions,
 Weather conditions,
 Symptoms

SBR339B

EXAMPLE OF DIAGNOSIS SHEET

Customer name	Model & Year	VIN	
Engine #	Trans.	Mileage	
Incident Date	Manuf. Date	In Service Date	
Symptoms	<input type="checkbox"/> Noise and vibration (from engine compartment)	<input type="checkbox"/> ABS warning lamp activates	<input type="checkbox"/> Pedal operation
	<input type="checkbox"/> Noise and vibration (from axle)	<input type="checkbox"/> SLIP warning lamp activates	<input type="checkbox"/> Large stroke pedal operation
	<input type="checkbox"/> TCS does not work (drive wheels slip when accelerating)	<input type="checkbox"/> ABS does not work (wheels slip when braking)	<input type="checkbox"/> Firm pedal
	<input type="checkbox"/> Lack of sense of acceleration		
Engine conditions	<input type="checkbox"/> When starting <input type="checkbox"/> After starting		
Road conditions	<input type="checkbox"/> Low friction road (<input type="checkbox"/> Snow <input type="checkbox"/> Gravel <input type="checkbox"/> Other) <input type="checkbox"/> Bumps/potholes		
Driving conditions	<input type="checkbox"/> Full-acceleration <input type="checkbox"/> High speed cornering <input type="checkbox"/> Vehicle speed: Greater than 10 km/h (6 MPH) <input type="checkbox"/> Vehicle speed: 10 km/h (6 MPH) or less <input type="checkbox"/> Vehicle is stopped		
Applying brake conditions	<input type="checkbox"/> Suddenly <input type="checkbox"/> Gradually		
Other conditions	<input type="checkbox"/> Operation of electrical equipment <input type="checkbox"/> Shift change <input type="checkbox"/> Other descriptions		

WFIA0097E

A
B
C
D
E
BRC
G
H
I
J
K
L
M
N
O
P

TROUBLE DIAGNOSIS

< SERVICE INFORMATION >

[VDC/TCS/ABS]

Component Parts and Harness Connector Location

INFOID:000000005612152

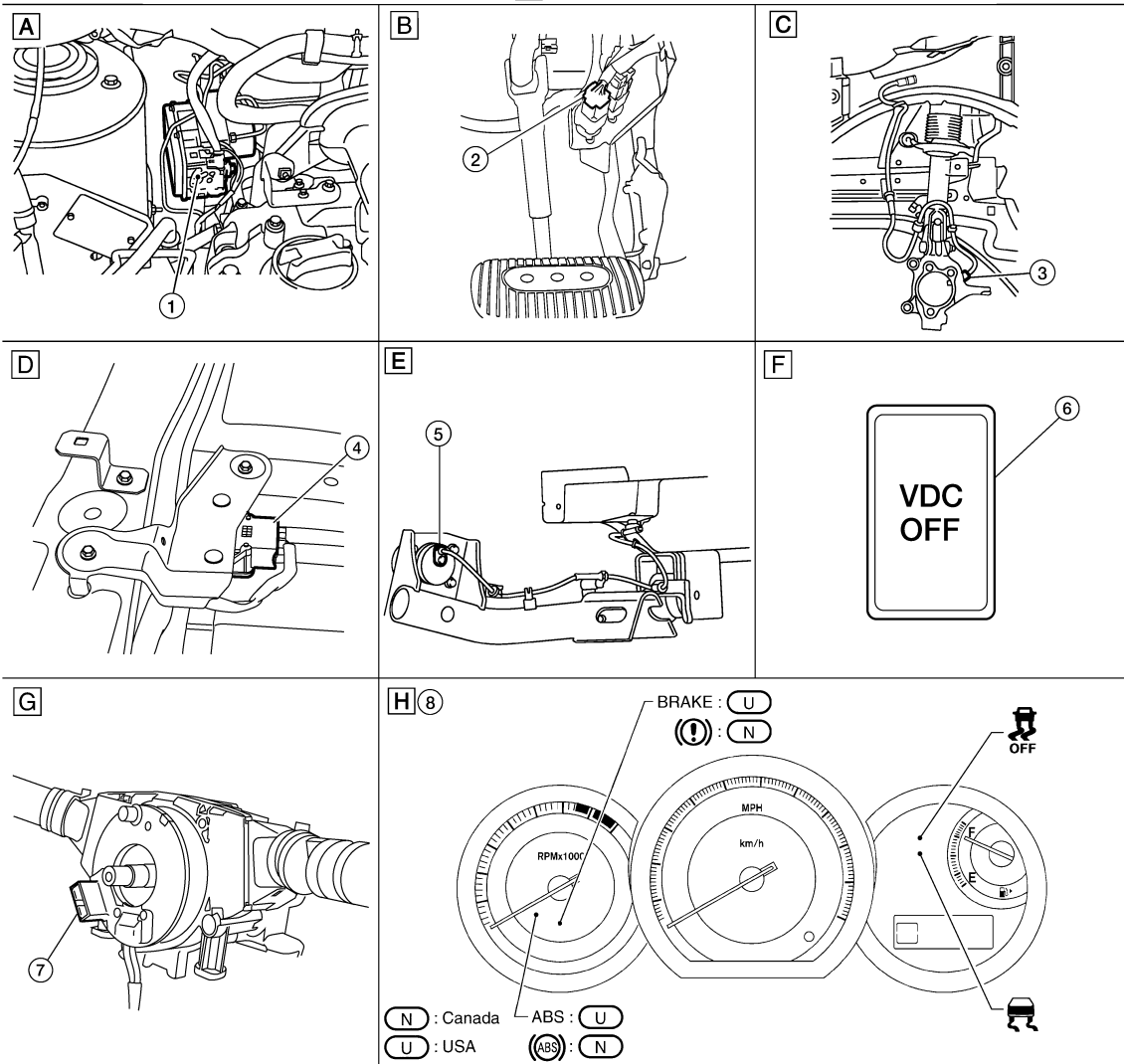
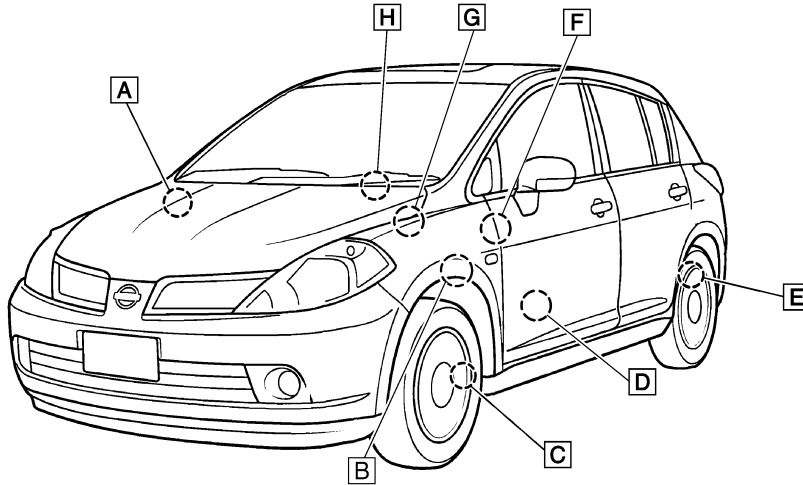

1. ABS actuator and electric unit (control unit) E33

2. Stop lamp switch E13

3. Front wheel sensor LH E18
Front wheel sensor RH E117

TROUBLE DIAGNOSIS

[VDC/TCS/ABS]

< SERVICE INFORMATION >

4. Yaw rate/side/decel G sensor B3 (driver seat and carpet removed for clarity)
5. Rear wheel sensor LH B123
Rear wheel sensor RH B122
6. VDC OFF switch M34
7. Steering angle sensor M64 (steering wheel removed for clarity)
8. Combination meter M24

Schematic

INFOID:000000005612153

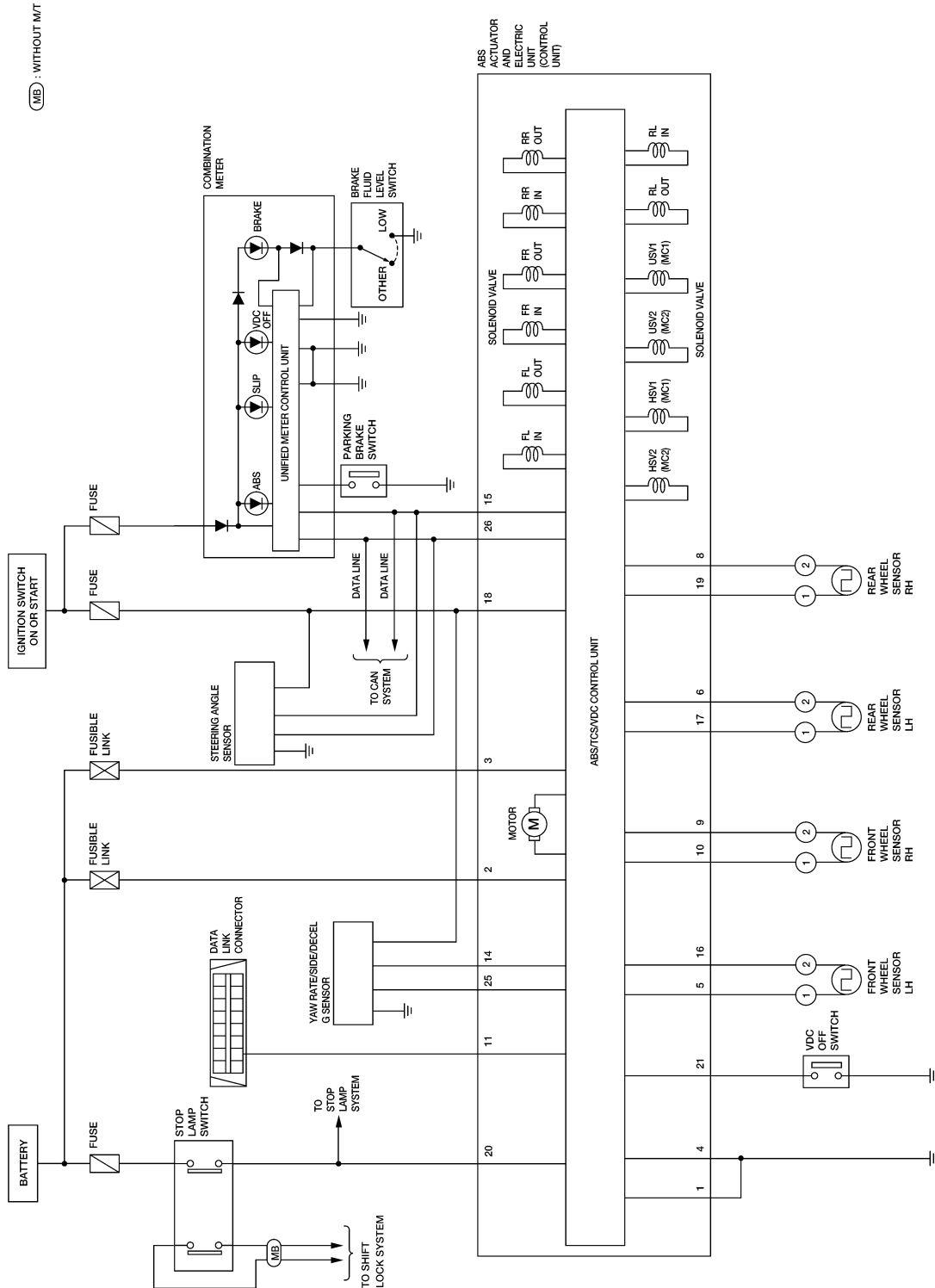

ABFWA0108GB

A
B
C
D
E
BRC
G
H
I
J
K
L
M
N
O
P

TROUBLE DIAGNOSIS

< SERVICE INFORMATION >

[VDC/TCS/ABS]

BRC-VDC-02

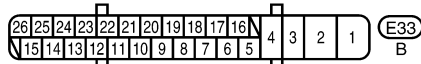
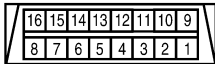
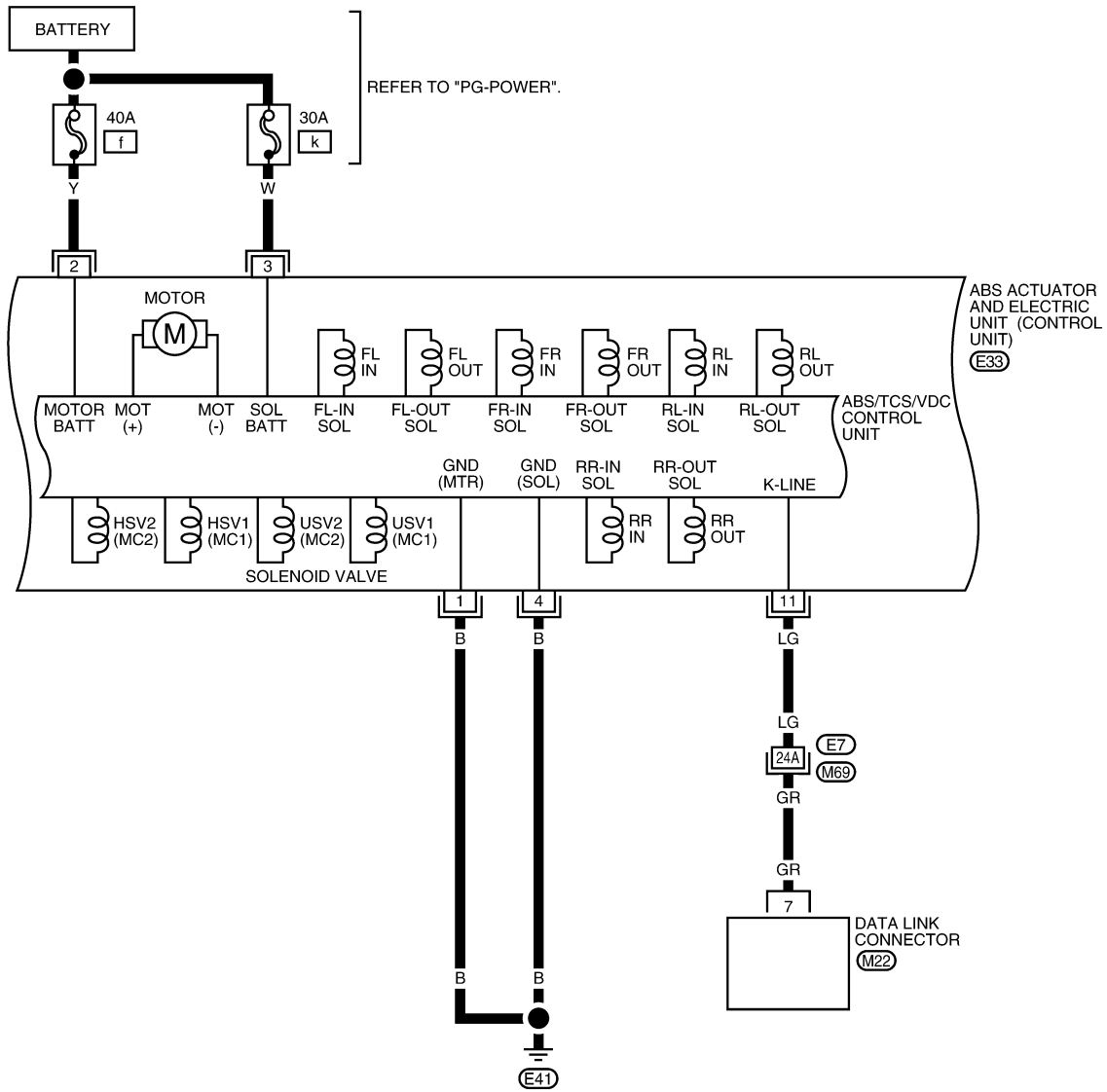

REFER TO THE FOLLOWING.
 (M69) - SUPER MULTIPLE JUNCTION (SMJ)

ABFWA0110GB

TROUBLE DIAGNOSIS

< SERVICE INFORMATION >

[VDC/TCS/ABS]

BRC-VDC-03

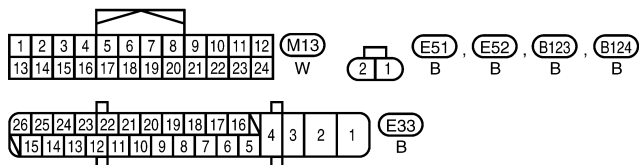
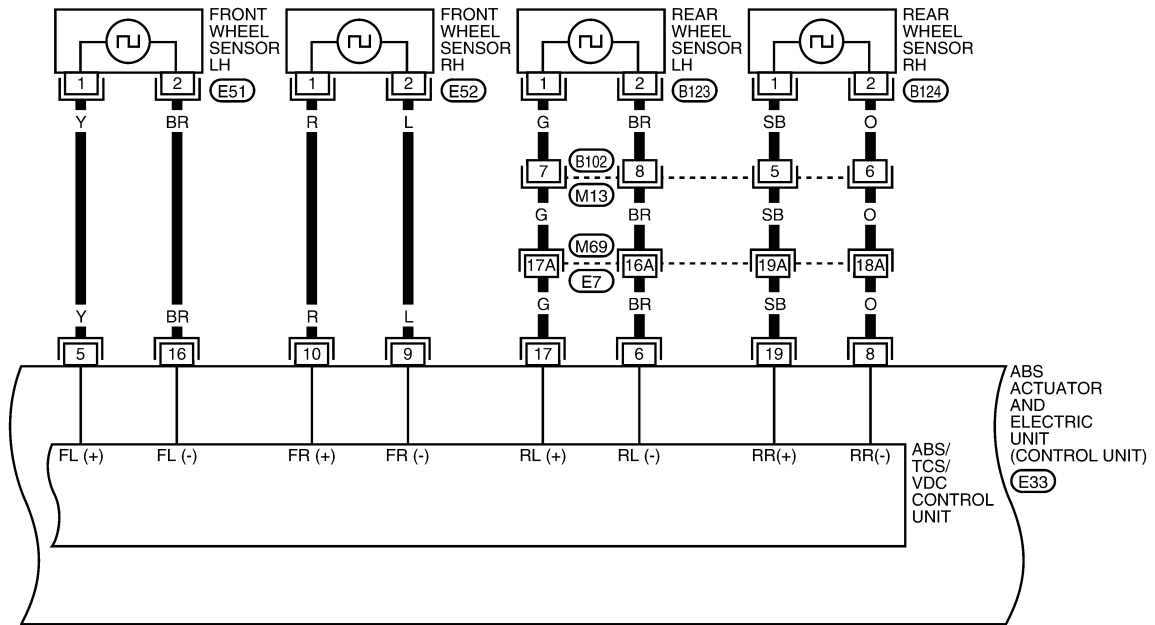

REFER TO THE FOLLOWING.
 (M69) - SUPER MULTIPLE JUNCTION (SMJ)

ABFWA0111GB

TROUBLE DIAGNOSIS

< SERVICE INFORMATION >

[VDC/TCS/ABS]

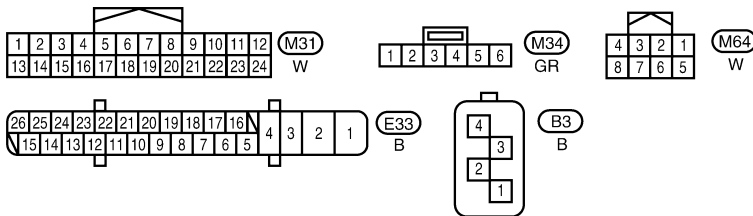
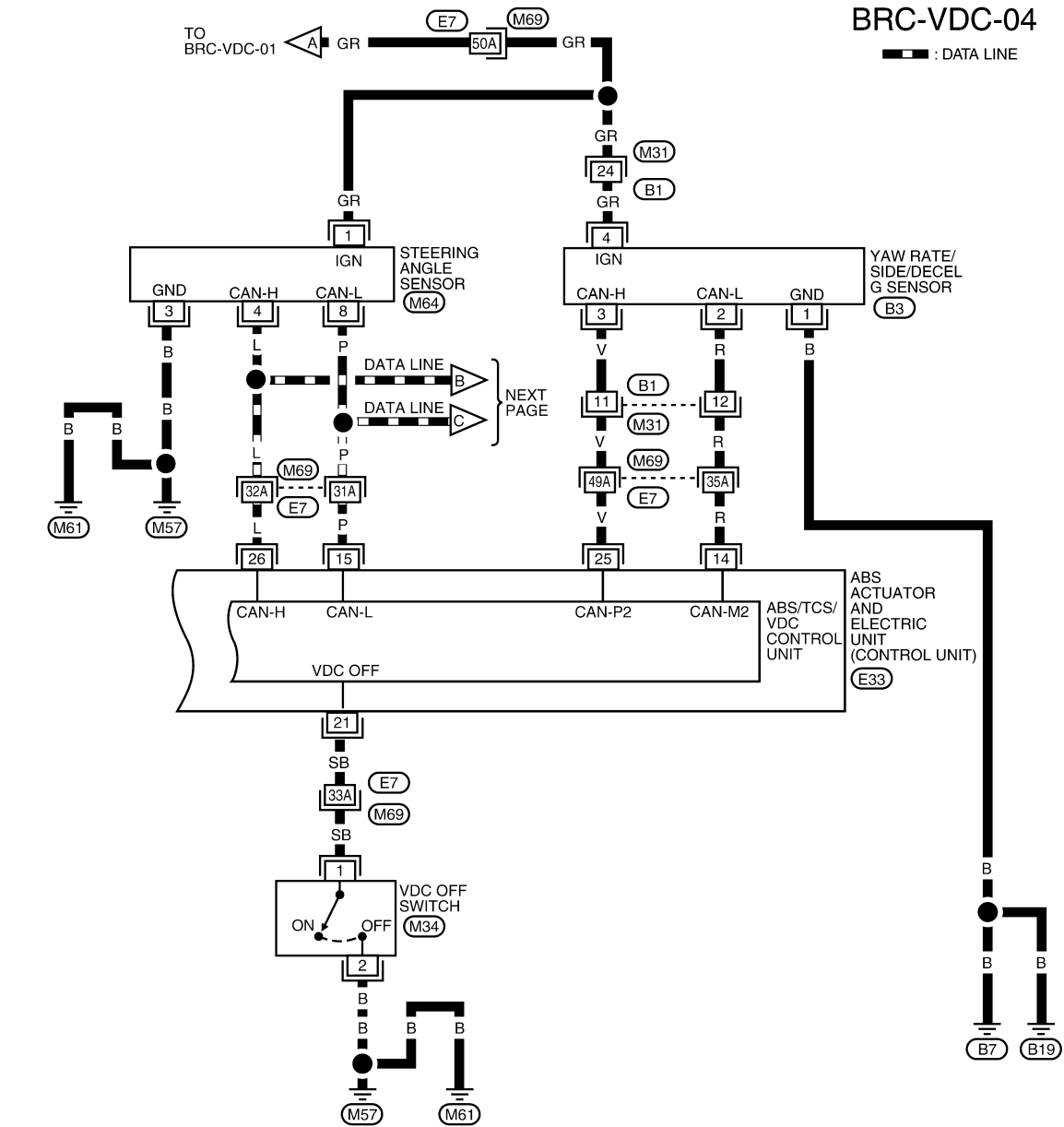

REFER TO THE FOLLOWING.
 (M69) - SUPER MULTIPLE JUNCTION (SMJ)

ABFWA0112GB

TROUBLE DIAGNOSIS

< SERVICE INFORMATION >

[VDC/TCS/ABS]

BRC-VDC-05

— : DATA LINE

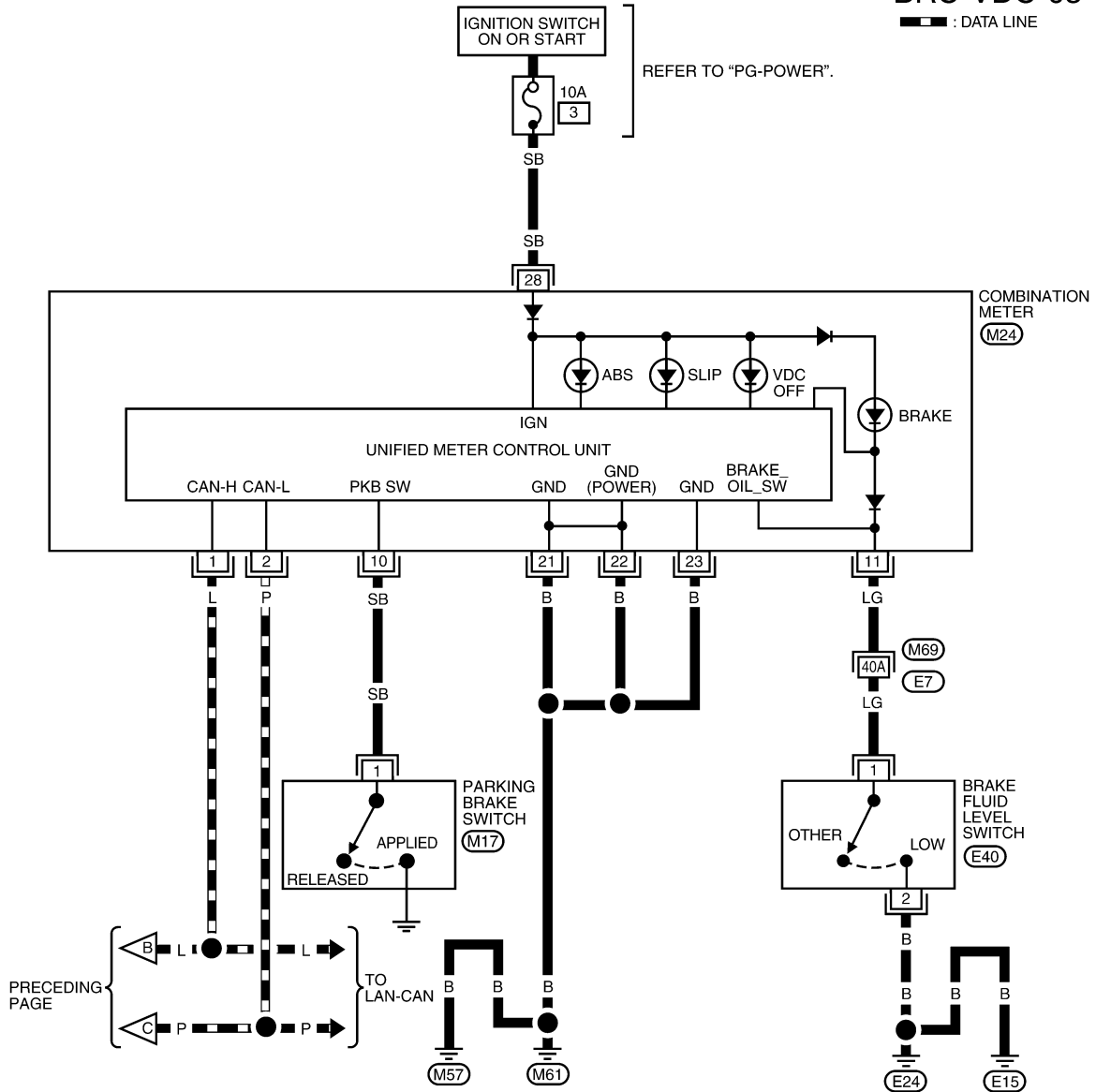

REFER TO THE FOLLOWING.

(M69) - SUPER MULTIPLE JUNCTION (SMJ)

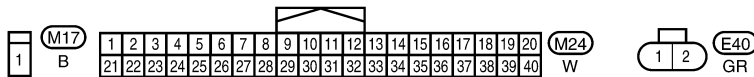

ABFWA0113GB

INFOID:000000005612155

Basic Inspection

BRAKE FLUID LEVEL, FLUID LEAK, AND BRAKE PAD INSPECTION

1. Check fluid level in the brake fluid reservoir. If fluid level is low, add fluid.
2. Check the brake piping and around the ABS actuator and electric unit (control unit) for leaks. If there is leaking or seeping fluid, check the following items.
 - If ABS actuator and electric unit (control unit) connection is loose, tighten the piping to the specified torque and recheck for leaks.

TROUBLE DIAGNOSIS

< SERVICE INFORMATION >

[VDC/TCS/ABS]

- If there is damage to the connection flare nut or ABS actuator and electric unit (control unit) screw, replace the damaged part and recheck for leaks.
- When there is fluid leaking or seeping from a fluid connection, use a clean cloth to wipe off the fluid and recheck for leaks. If fluid is still seeping out, replace the damaged part. If the fluid is leaking at the ABS actuator and electric unit (control unit), replace the ABS actuator and electric unit (control unit) assembly.

CAUTION:

The ABS actuator and electric unit (control unit) cannot be disassembled and must be replaced as an assembly.

3. Check the brake pads for excessive wear.

POWER SYSTEM TERMINAL LOOSENESS AND BATTERY INSPECTION

Make sure the battery positive cable, negative cable and ground connection are not loose. In addition, make sure the battery is sufficiently charged.

ABS WARNING LAMP, SLIP INDICATOR LAMP AND VDC OFF INDICATOR LAMP INSPECTION

1. Make sure ABS warning lamp, SLIP indicator lamp and VDC OFF indicator lamp (when VDC OFF switch is off), turn on for approximately 2 seconds when the ignition switch is turned ON. If they do not, check the VDC OFF indicator lamp and then VDC OFF switch. Refer to [BRC-79. "Component Inspection"](#). Check CAN communications. If there are no errors with VDC OFF switch and CAN communication system, check combination meter. Refer to [DI-32. "Component Inspection"](#).
2. Make sure the lamps turn off approximately 2 seconds after the ignition switch is turned ON. If the lamp does not turn off, conduct self-diagnosis.
3. With the engine running, make sure VDC OFF indicator lamp turns on and off when VDC OFF switch is turned on and off. If the indicator lamp status does not correspond to switch operation, check the VDC OFF switch system. Refer to [BRC-79. "Component Inspection"](#).
4. Make sure ABS warning lamp, SLIP indicator lamp and VDC OFF indicator lamp turn off approximately 2 seconds after the engine is started. If ABS warning lamp, SLIP indicator lamp or VDC OFF indicator lamp have not turned off 10 seconds after the engine has been started, conduct self-diagnosis of the ABS actuator and electric unit (control unit).
5. After conducting the self-diagnosis, be sure to erase the error memory. Refer to [BRC-60. "CONSULT-III Function \(ABS\)"](#).

Warning Lamp and Indicator Timing

INFOID:000000005612156

x: ON - : OFF

Condition	ABS warning lamp	VDC OFF indicator lamp	SLIP indicator lamp	Remarks
When the ignition switch is OFF	-	-	-	-
After the ignition switch is turned ON For approx. 2 seconds	x	x	x	-
Ignition switch ON Approx. 2 seconds later	-	-	-	-
When the VDC OFF switch turns ON (VDC function OFF).	-	x	-	-
ABS/TCS/VDC malfunction	x	x	x	-
	x	x	-	When the ABS/TCS/VDC control unit is malfunctioning (power supply or ground malfunction).
When the VDC is malfunctioning.	-	x	x	-

Control Unit Input/Output Signal Standard

INFOID:000000005612157

REFERENCE VALUE FROM CONSULT-III

CAUTION:

The display shows the control unit calculation data, so a normal value might be displayed even in the event the output circuit (harness) is open or short circuited.

TROUBLE DIAGNOSIS

< SERVICE INFORMATION >

[VDC/TCS/ABS]

Monitor item	Display content	Data monitor		Note: Error inspection checklist
		Condition	Reference value in normal operation	
FR LH SENSOR FR RH SENSOR RR LH SENSOR RR RH SENSOR	Wheel speed	Vehicle stopped	0 [km/h (mph)]	BRC-67. "Wheel Sensor System Inspection"
		Vehicle running (Note 1)	Almost in accordance with speedometer display (within ±10%)	
FR RH IN SOL FR RH OUT SOL FR LH IN SOL FR LH OUT SOL RR RH IN SOL RR RH OUT SOL RR LH IN SOL RR LH OUT SOL	Solenoid valve operation	Actuator (solenoid) is active ("ACTIVE TEST" with CONSULT-III) or actuator relay is inactive (in fail-safe mode).	On	BRC-72. "Solenoid and VDC Change-Over Valve System Inspection"
		When actuator (solenoid) is not active and actuator relay is active (ignition switch ON).	Off	
STOP LAMP SW	Brake pedal operation	Brake pedal depressed	On	BRC-74. "Stop Lamp Switch System Inspection"
		Brake pedal released	Off	
MOTOR RELAY	Operation status of motor and motor relay	Ignition switch ON or engine running (ABS not operated)	Off	BRC-73. "Actuator Motor, Motor Relay, and Circuit Inspection"
		Ignition switch ON or engine running (ABS operated)	On	
ACTUATOR RLY	Actuator relay operation status	Vehicle stopped (Ignition switch ON)	Off	BRC-73. "Actuator Motor, Motor Relay, and Circuit Inspection"
		Vehicle stopped (Engine running)	On	
ABS WARN LAMP	ABS warning lamp ON condition (Note 2)	ABS warning lamp ON	On	BRC-83. "ABS Warning Lamp Does Not Come On When Ignition Switch Is Turned On"
		ABS warning lamp OFF	Off	
OFF LAMP	VDC OFF indicator lamp status (Note 2)	When VDC OFF indicator lamp is ON	On	BRC-79. "CAN Communication System Inspection"
		When VDC OFF indicator lamp is OFF	Off	
OFF SW	VDC OFF switch ON/OFF status	VDC OFF switch ON (When VDC OFF indicator lamp is ON)	On	BRC-79. "Component Inspection"
		VDC OFF switch OFF (When VDC OFF indicator lamp is OFF)	Off	
SLIP LAMP	SLIP indicator lamp status (Note 2)	When SLIP indicator lamp is ON	On	BRC-79. "CAN Communication System Inspection"
		When SLIP indicator lamp is OFF	Off	
BATTERY VOLT	Battery voltage supplied to ABS actuator and electric unit (control unit)	Ignition switch ON	10 to 16V	BRC-75. "ABS/TCS/VDC Control Unit Power and Ground Systems Inspection"
GEAR	Manual mode gear position determined by TCM	Ignition switch ON	1 2 3 4 5	—
YAW RATE SEN	Yaw rate detected by yaw rate/side G sensor	Vehicle stopped	Approx. 0 d/s	BRC-70. "Yaw Rate/Side/Decel G Sensor System Inspection"
		Vehicle turning	-75 to 75 d/s	

TROUBLE DIAGNOSIS

< SERVICE INFORMATION >

[VDC/TCS/ABS]

Monitor item	Display content	Data monitor		Note: Error inspection checklist
		Condition	Reference value in normal operation	
ACCEL POS SIG	Open/close condition of throttle valve (linked with accelerator pedal)	Accelerator pedal not depressed (ignition switch is ON)	0%	BRC-79. "CAN Communication System Inspection"
		Depress accelerator pedal (ignition switch is ON)	0 to 100%	
SIDE G-SENSOR	Transverse G detected by side G-sensor	Vehicle stopped	Approx. 0 m/s ²	BRC-70. "Yaw Rate/Side/Decel G Sensor System Inspection"
		Vehicle turning right	negative value (m/s ²)	
		Vehicle turning left	positive value (m/s ²)	
STR ANGLE SIG	Steering angle detected by steering angle sensor	Straight-ahead	Approx. 0°	BRC-69. "Steering Angle Sensor System Inspection"
		Steering wheel turned	-720 to 720°	
PRESS SENSOR	Brake fluid pressure detected by pressure sensor	With ignition switch ON and brake pedal released	Approx. 0 bar	BRC-77. "Pressure Sensor System Inspection"
		With ignition switch ON and brake pedal depressed	-40 to 300 bar	
EBD SIGNAL	EBD operation	EBD is active	On	—
		EBD is inactive	Off	
ABS SIGNAL	ABS operation	ABS is active	On	—
		ABS is inactive	Off	
TCS SIGNAL	TCS operation	TCS is active	On	—
		TCS is inactive	Off	
VDC SIGNAL	VDC operation	VDC is active	On	—
		VDC is inactive	Off	
EBD FAIL SIG	EBD fail-safe signal	In EBD fail safe mode	On	—
		EBD is normal	Off	
ABS FAIL SIG	ABS fail-safe signal	In ABS fail safe mode	On	—
		ABS is normal	Off	
TCS FAIL SIG	TCS fail-safe signal	In TCS fail safe mode	On	—
		TCS is normal	Off	
VDC FAIL SIG	VDC fail-safe signal	In VDC fail safe mode	On	—
		VDC is normal	Off	
CRANKING SIG	Crank operation	Crank is active	On	—
		Crank is inactive	Off	
FLUID LEV SW	Status of brake fluid level switch	When brake fluid level switch ON	On	BRC-76. "Brake Fluid Level Switch System Inspection"
		When brake fluid level switch OFF	Off	
PARK BRAKE SW	Status of parking brake switch	Parking brake switch is active	On	BRC-79. "Component Inspection"
		Parking brake switch is inactive	Off	

A
B
C
D
E
BRC
G
H
I
J
K
L
M
N
O
P

TROUBLE DIAGNOSIS

< SERVICE INFORMATION >

[VDC/TCS/ABS]

Monitor item	Display content	Data monitor		Note: Error inspection checklist
		Condition	Reference value in normal operation	
USV[FL-RR] USV[FR-RL] HSV[FL-RR] HSV[FR-RL]	VDC switch-over valve status	When actuator (switch-over valve) is active ("ACTIVE TEST" with CONSULT-III) or actuator relay is inactive (when in fail-safe mode).	On	BRC-72, "Solenoid and VDC Change-Over Valve System Inspection"
		When actuator (switch-over valve) is not active and actuator relay is active (ignition switch ON).	Off	
V/R OUPUT	Solenoid valve relay activated	When solenoid valve relay is active (ignition switch OFF)	On	
		When solenoid valve relay is not active (in fail-safe mode)	Off	
M/R OUTPUT	Actuator motor and motor relay activated	When actuator motor and motor relay are active ("ACTIVE TEST" with CONSULT-III)	On	BRC-73, "Actuator Motor, Motor Relay, and Circuit Inspection"
		When actuator motor and motor relay are inactive	Off	
ENGINE RPM	With engine running	With engine stopped	0 rpm	BRC-68, "Engine System Inspection"
		Engine running	Almost in accordance with tachometer display	

Note 1: Confirm tire pressure is normal.

Note 2: On and Off timing for warning lamp and indicator lamp.

CONSULT-III Function (ABS)

INFOID:000000005612158

CONSULT-III can display each diagnostic item using the diagnostic test modes shown following.

ABS diagnostic mode	Description
WORK SUPPORT	Supports inspection and adjustments. Commands are transmitted to the ABS actuator and electric unit (control unit) for setting the status suitable for required operation, input/output signals are received from the ABS actuator and electric unit (control unit) and received data is displayed.
SELF DIAGNOSTIC RESULT	Displays ABS actuator and electric unit (control unit) self-diagnosis results.
DATA MONITOR	Displays ABS actuator and electric unit (control unit) input/output data in real time.
CAN DIAG SUPPORT MNTR	The result of transmit/receive diagnosis of CAN communication can be read.
ACTIVE TEST	Operation of electrical loads can be checked by sending drive signal to them.
FUNCTION TEST	Conducted by CONSULT-III instead of a technician to determine whether each system is "OK" or "NG".
ECU IDENTIFICATION	ABS actuator and electric unit (control unit) part number can be read.

SELF-DIAGNOSIS

Description

If an error is detected in the system, the ABS warning lamp will turn on. In this case, perform self-diagnosis as follows:

Operation Procedure

1. Turn ignition switch OFF.
2. Connect CONSULT-III To the data link connector.
3. Turn ignition switch ON.
4. Start engine and drive at approximately 30 km/h (19 MPH) for approximately 1 minute.
5. After stopping the vehicle, with the engine running, touch "ABS", "SELF-DIAG RESULTS" in order on the CONSULT-III screen.

TROUBLE DIAGNOSIS

[VDC/TCS/ABS]

< SERVICE INFORMATION >

6. The self-diagnostic results are displayed.
 - When "NO DTC IS DETECTED" is displayed, check the ABS warning lamp, SLIP indicator lamp and VDC OFF indicator lamp.
7. Conduct the appropriate inspection from the display item list, and repair or replace the malfunctioning component.
8. Start engine and drive at approximately 30 km/h (19 MPH) for approximately 1 minute.

CAUTION:

 - **When a wheel sensor "short-circuit" is detected, if the vehicle is not driven at 30 km/h (19 MPH) for at least 1 minute, the ABS warning lamp will not turn off even if the malfunction is repaired.**
9. Turn ignition switch OFF to prepare for erasing the memory.
10. Start the engine and touch "ABS", "SELF-DIAG RESULTS", "ERASE" in order on the CONSULT-III screen to erase the error memory.
If "ABS" is not indicated, go to [GI-36. "CONSULT-III Data Link Connector \(DLC\) Circuit"](#).

CAUTION:

If the error memory is not erased, re-conduct the operation from step 5.
11. For the final inspection, drive at approximately 30 km/h (19 MPH) for approximately 1 minute and confirm that the ABS warning lamp, SLIP indicator lamp, and VDC OFF indicator lamp are off.

Display Item List

A
B
C
D
E
BRC

Self-diagnostic item	Malfunction detecting condition	Check system
RR RH SENSOR 1 [C1101]	Circuit of rear RH wheel sensor is open.	
RR LH SENSOR 1 [C1102]	Circuit of rear LH wheel sensor is open.	
FR RH SENSOR 1 [C1103]	Circuit of front RH wheel sensor is open.	
FR LH SENSOR 1 [C1104]	Circuit of front LH wheel sensor is open.	
RR RH SENSOR 2 [C1105]	Circuit of rear RH wheel sensor is shorted, or sensor power voltage is unusual. ABS actuator and electric unit (control unit) cannot identify sensor pulses, because of large gap between wheel sensor and sensor rotor.	BRC-67. "Wheel Sensor System Inspection" (Note 1)
RR LH SENSOR 2 [C1106]	Circuit of rear LH wheel sensor is shorted, or sensor power voltage is unusual. ABS actuator and electric unit (control unit) cannot identify sensor pulses, because of large gap between wheel sensor and sensor rotor.	
FR RH SENSOR 2 [C1107]	Circuit of front RH wheel sensor is shorted, or sensor power voltage is unusual. ABS actuator and electric unit (control unit) cannot identify sensor pulses, because of large gap between wheel sensor and sensor rotor.	
FR LH SENSOR 2 [C1108]	Circuit of front LH wheel sensor is shorted, or sensor power voltage is unusual. ABS actuator and electric unit (control unit) cannot identify sensor pulses, because of large gap between wheel sensor and sensor rotor.	
BATTERY VOLTAGE [ABNORMAL] [C1109]	ABS actuator and electric unit (control unit) power voltage is too low.	BRC-75. "ABS/TCS/VDC Control Unit Power and Ground Systems Inspection"
CONTROLLER FAILURE [C1110]	Internal malfunction of ABS actuator and electric unit (control unit).	BRC-68. "ABS/TCS/VDC Control Unit Inspection"
PUMP MOTOR [C1111]	During actuator motor operation with ON, when actuator motor turns OFF or when control line for actuator motor relay is open.	BRC-73. "Actuator Motor, Motor Relay, and Circuit Inspection"
	During actuator motor operation with OFF, when actuator motor turns ON or when control line for relay is shorted to ground.	

G
H
I
J
K
L
M
N
O
P

TROUBLE DIAGNOSIS

< SERVICE INFORMATION >

[VDC/TCS/ABS]

Self-diagnostic item	Malfunction detecting condition	Check system
MAIN RELAY [C1114]	During actuator relay OFF, when the actuator relay turns ON, or when the control line for the relay is shorted to ground.	BRC-72. "Solenoid and VDC Change-Over Valve System Inspection"
	During actuator relay ON, when the actuator relay turns ON, or when the control line for the relay is open.	
ABS SENSOR [ABNORMAL SIGNAL] [C1115]	When wheel sensor input signal is malfunctioning.	BRC-67. "Wheel Sensor System Inspection" (NOTE 1)
STOP LAMP SW [C1116]	Stop lamp switch or circuit malfunction.	BRC-74. "Stop Lamp Switch System Inspection"
FR LH IN ABS SOL [C1120]	Circuit of front LH IN ABS solenoid is open or shorted, or control line is open or shorted to power supply or ground.	BRC-72. "Solenoid and VDC Change-Over Valve System Inspection"
FR LH OUT ABS SOL [C1121]	Circuit of front LH OUT ABS solenoid is open or shorted, or control line is open or shorted to power supply or ground.	
FR RH IN ABS SOL [C1122]	Circuit of front RH IN ABS solenoid is open or shorted, or control line is open or shorted to power supply or ground.	
FR RH OUT ABS SOL [C1123]	Circuit of front RH OUT ABS solenoid is open or shorted, or control line is open or shorted to power supply or ground.	
RR LH IN ABS SOL [C1124]	Circuit of rear LH IN ABS solenoid is open or shorted, or control line is open or shorted to power supply or ground.	
RR LH OUT ABS SOL [C1125]	Circuit of rear LH OUT ABS solenoid is open or shorted, or control line is open or shorted to power supply or ground.	
RR RH IN ABS SOL [C1126]	Circuit of rear RH IN ABS solenoid is open or shorted, or control line is open or shorted to power supply or ground.	
RR RH OUT ABS SOL [C1127]	Circuit of rear RH OUT ABS solenoid is open or shorted, or control line is open or shorted to power supply or ground.	
ENGINE SIGNAL 1 [C1130]	ECM judges the communication between ABS/TCS/VDC control unit and ECM is abnormal.	BRC-68. "Engine System Inspection"
ENGINE SIGNAL 2 [C1131]	ECM judges the communication between ABS/TCS/VDC control unit and ECM is abnormal.	
ENGINE SIGNAL 3 [C1132]	ECM judges the communication between ABS/TCS/VDC control unit and ECM is abnormal.	
ENGINE SIGNAL 4 [C1133]	ECM judges the communication between ABS/TCS/VDC control unit and ECM is abnormal.	
ENGINE SIGNAL 6 [C1136]	ECM judges the communication between ABS/TCS/VDC control unit and ECM is abnormal.	
PRESS SEN CIRCUIT [C1142]	Pressure sensor signal line is open or shorted, or pressure sensor is malfunctioning.	BRC-77. "Pressure Sensor System Inspection"
ST ANGLE SEN CIRCUIT [C1143]	Neutral position of steering angle sensor is dislocated, or steering angle sensor is malfunctioning.	BRC-69. "Steering Angle Sensor System Inspection"
ST ANGLE SEN SIGNAL [C1144]	Neutral position correction of steering angle sensor is not finished.	
YAW RATE SENSOR [C1145]	Yaw rate sensor has generated an error, or yaw rate sensor signal line is open or shorted.	BRC-70. "Yaw Rate/Side/Decel G Sensor System Inspection"
SIDE G-SEN CIRCUIT [C1146]	Lateral G-sensor is malfunctioning, or signal line of lateral G-sensor is open or shorted.	

TROUBLE DIAGNOSIS

< SERVICE INFORMATION >

[VDC/TCS/ABS]

Self-diagnostic item	Malfunction detecting condition	Check system
USV LINE [FL-RR] [C1147]	Front side VDC switch-over solenoid valve (cut valve) is open or shorted, or control line is open or shorted to power supply or ground.	BRC-72. "Solenoid and VDC Change-Over Valve System Inspection"
USV LINE [FR-RL] [C1148]	Rear side VDC switch-over solenoid valve (cut valve) is open or shorted, or control line is open or shorted to power supply or ground.	
HSV LINE [FL-RR] [C1149]	Front side VDC switch-over solenoid valve (suction valve) is open or shorted, or control line is open or shorted to power supply or ground.	
HSV LINE [FR-RL] [C1150]	Rear side VDC switch-over solenoid valve (suction valve) is open or shorted, or control line is open or shorted to power supply or ground.	
EMERGENCY BRAKE [C1153]	When ABS actuator and electric unit (control unit) is malfunctioning. (Pressure increase is too much or too little)	BRC-68. "ABS/TCS/VDC Control Unit Inspection"
PNP POS SIG [C1154]	Transmission range switch signal or communication line between the ABS actuator and electric unit (control unit) and TCM is open or shorted.	BRC-78. "Transmission Range Switch System Inspection"
BR FLUID LEVEL LOW [C1155]	Brake fluid level drops or circuit between ABS actuator and electric unit (control unit) and brake fluid level switch is open or shorted.	BRC-76. "Brake Fluid Level Switch System Inspection"
ST ANG SEN COM CIR [C1156]	CAN communication line or steering angle sensor has generated an error.	BRC-79. "CAN Communication System Inspection" (Note 2)
VARIANT CODING [C1170]	In case where VARIANT CODING is different.	BRC-68. "ABS/TCS/VDC Control Unit Inspection"
CAN COMM CIRCUIT [U1000]	<ul style="list-style-type: none"> CAN communication line is open or shorted. ABS actuator and electric unit (control unit) internal malfunction Battery voltage for ECM is suddenly interrupted for approximately 0.5 seconds or more. 	BRC-79. "CAN Communication System Inspection" (Note 2)

Note 1. If wheel sensor 2 for each wheel is indicated, check ABS actuator and electric unit (control unit) power supply voltage in addition to wheel sensor circuit check.

Note 2. If multiple malfunctions are detected including CAN communication line [U1000], perform diagnosis for CAN communication line first.

DATA MONITOR

Display Item List

Item (Unit)	Data monitor item selection			Remarks
	ECU INPUT SIGNALS	MAIN SIGNALS	SELECTION FROM MENU	
FR LH SENSOR (km/h, mph)	×	×	×	Wheel speed (km/h, mph) calculated by front LH wheel sensor signal is displayed.
FR RH SENSOR (km/h, mph)	×	×	×	Wheel speed (km/h, mph) calculated by front RH wheel sensor signal is displayed.
RR LH SENSOR (km/h, mph)	×	×	×	Wheel speed (km/h, mph) calculated by rear LH wheel sensor signal is displayed.
RR RH SENSOR (km/h, mph)	×	×	×	Wheel speed (km/h, mph) calculated by rear RH wheel sensor signal is displayed.
FR RH IN SOL (On/Off)	—	×	×	Front RH IN ABS solenoid (On/Off) status is displayed.
FR RH OUT SOL (On/Off)	—	×	×	Front RH OUT ABS solenoid (On/Off) status is displayed.
FR LH IN SOL (On/Off)	—	×	×	Front LH IN ABS solenoid (On/Off) status is displayed.

TROUBLE DIAGNOSIS

< SERVICE INFORMATION >

[VDC/TCS/ABS]

FR LH OUT SOL (On/Off)	—	×	×	Front LH OUT ABS solenoid (On/Off) status is displayed.
RR RH IN SOL (On/Off)	—	×	×	Rear RH IN ABS solenoid (On/Off) status is displayed.
RR RH OUT SOL (On/Off)	—	×	×	Rear RH OUT ABS solenoid (On/Off) status is displayed.
RR LH IN SOL (On/Off)	—	×	×	Rear LH IN ABS solenoid (On/Off) status is displayed.
RR LH OUT SOL (On/Off)	—	×	×	Rear LH OUT ABS solenoid (On/Off) status is displayed.
STOP LAMP SW (On/Off)	×	×	×	Stop lamp switch (On/Off) status is displayed.
MOTOR RELAY (On/Off)	—	×	×	ABS motor relay signal (On/Off) status is displayed.
ACTUATOR RLY (On/Off)	—	×	×	ABS actuator relay signal (On/Off) status is displayed.
ABS WARN LAMP (On/Off)	—	×	×	ABS warning lamp (On/Off) status is displayed.
OFF LAMP (On/Off)	—	×	×	VDC OFF lamp (On/Off) status is displayed.
OFF SW (On/Off)	×	×	×	VDC OFF switch (On/Off) status is displayed.
SLIP LAMP (On/Off)	—	×	×	SLIP indicator lamp (On/Off) status is displayed.
BATTERY VOLT (V)	×	×	×	Voltage (V) supplied to ABS actuator and electric unit (control unit) is displayed.
GEAR (1, 2, 3, 4)	×	×	×	A/T gear position (1, 2, 3, 4) determined by TCM is displayed.
YAW RATE SEN (d/s)	×	×	×	Yaw rate (d/s) detected by yaw rate sensor is displayed.
ACCEL POS SIG (%)	×	—	×	Throttle valve open/close (%) status judged by CAN communication signal is displayed.
SIDE G-SENSOR (m/s ²)	×	—	×	Lateral acceleration (m/s ²) detected by side G sensor is displayed.
STR ANGLE SIG (deg)	×	—	×	Steering angle (deg) detected by steering angle sensor is displayed.
PRESS SENSOR (bar)	×	—	×	Brake fluid pressure detected by pressure sensor is displayed.
EBD SIGNAL (On/Off)	—	—	×	EBD operation (On/Off) status is displayed.
ABS SIGNAL (On/Off)	—	—	×	ABS operation (On/Off) status is displayed.
TCS SIGNAL (On/Off)	—	—	×	TCS operation (On/Off) status is displayed.
VDC SIGNAL (On/Off)	—	—	×	VDC operation (On/Off) status is displayed.
EBD FAIL SIG (On/Off)	—	—	×	EBD fail signal (On/Off) status is displayed.
ABS FAIL SIG (On/Off)	—	—	×	ABS fail signal (On/Off) status is displayed.
TCS FAIL SIG (On/Off)	—	—	×	TCS fail signal (On/Off) status is displayed.
VDC FAIL SIG (On/Off)	—	—	×	VDC fail signal (On/Off) status is displayed.

TROUBLE DIAGNOSIS

< SERVICE INFORMATION >

[VDC/TCS/ABS]

CRANKING SIG (On/Off)	—	—	×	Cranking condition (On/Off) status is displayed.
FLUID LEV SW (On/Off)	×	—	×	Brake fluid level switch (On/Off) status is displayed.
PARK BRAKE SW (On/Off)	×	—	×	Parking brake switch (On/Off) status is displayed.
USV[FL-RR] (On/Off)	—	—	×	Primary side USV solenoid valve (On/Off) status is displayed.
USV[FR-RL] (On/Off)	—	—	×	Secondary side USV solenoid valve (On/Off) status is displayed.
HSV[FL-RR] (On/Off)	—	—	×	Primary side HSV solenoid valve (On/Off) status is displayed.
HSV[FR-RL] (On/Off)	—	—	×	Secondary side HSV solenoid valve (On/Off) status is displayed.
V/R OUTPUT (On/Off)	—	—	×	Valve relay operation signal (On/Off) status is displayed.
M/R OUTPUT (On/Off)	—	—	×	Motor relay operation signal (On/Off) status is displayed.
ENGINE RPM (rpm)	×	—	×	Engine speed judged by CAN communication signal is displayed.

×: Applicable

—: Not applicable

ACTIVE TEST

CAUTION:

- Do not perform active test while driving vehicle.
- Make sure to completely bleed air from brake system.
- The active test cannot be performed with the ABS warning lamp, VDC indicator lamp, SLIP indicator lamp or brake warning lamp on.
- ABS warning lamp, VDC OFF indicator lamp, SLIP indicator lamp and brake warning lamp are on during active test.

NOTE:

- When active test is performed while depressing the pedal, the pedal depression amount will change. This is normal. (Only solenoid valve and ABS motor)
- “TEST IS STOPPED” is displayed 10 seconds after operation start.
- After “TEST IS STOPPED” is displayed, to perform test again, touch BACK.

Test Item

SOLENOID VALVE

- When performing an active test of the ABS function, select “MAIN SIGNALS” for each test item.
- For ABS solenoid valve, touch “Up”, “Keep”, and “Down” on the display screen. For ABS solenoid valve (ACT), touch “Up”, “ACT UP”, “ACT KEEP” and confirm that solenoid valves operate as shown in the table below.

Operation		ABS solenoid valve			ABS solenoid valve (ACT)		
		Up	Keep	Down	Up	ACT UP	ACT KEEP
FR RH SOL	FR RH IN SOL	Off	On	On	—	—	—
	FR RH OUT SOL	Off	Off	On*	—	—	—
	USV [FR-RL]	Off	Off	On*	—	—	—
	HSV [FR-RL]	Off	Off	On*	—	—	—
FR LH SOL	FR LH IN SOL	Off	On	On	—	—	—
	FR LH OUT SOL	Off	Off	On*	—	—	—
	USV [FL-RR]	Off	Off	On*	—	—	—
	HSV [FL-RR]	Off	Off	On*	—	—	—

TROUBLE DIAGNOSIS

< SERVICE INFORMATION >

[VDC/TCS/ABS]

Operation		ABS solenoid valve			ABS solenoid valve (ACT)		
		Up	Keep	Down	Up	ACT UP	ACT KEEP
RR RH SOL	RR RH IN SOL	Off	On	On	—	—	—
	RR RH OUT SOL	Off	Off	On*	—	—	—
	USV [FL-RR]	Off	Off	On*	—	—	—
	HSV [FL-RR]	Off	Off	On*	—	—	—
RR LH SOL	RR LH IN SOL	Off	On	On	—	—	—
	RR LH OUT SOL	Off	Off	On*	—	—	—
	USV [FR-RL]	Off	Off	On*	—	—	—
	HSV [FR-RL]	Off	Off	On*	—	—	—
FR RH ABS SOLENOID (ACT)	FR RH IN SOL	—	—	—	Off	Off	Off
	FR RH OUT SOL	—	—	—	Off	Off	Off
	USV [FR-RL]	—	—	—	Off	On	On
	HSV [FR-RL]	—	—	—	Off	On*	Off
FR LH ABS SOLENOID (ACT)	FR LH IN SOL	—	—	—	Off	Off	Off
	FR LH OUT SOL	—	—	—	Off	Off	Off
	USV [FL-RR]	—	—	—	Off	Off	Off
	HSV [FL-RR]	—	—	—	Off	Off	Off
RR RH ABS SOLENOID (ACT)	RR RH IN SOL	—	—	—	Off	Off	Off
	RR RH OUT SOL	—	—	—	Off	Off	Off
	USV [FL-RR]	—	—	—	Off	Off	Off
	HSV [FL-RR]	—	—	—	Off	Off	Off
RR LH ABS SOLENOID (ACT)	RR LH IN SOL	—	—	—	Off	Off	Off
	RR LH OUT SOL	—	—	—	Off	Off	Off
	USV [FR-RL]	—	—	—	Off	On	On
	HSV [FR-RL]	—	—	—	Off	On*	Off

*: On for 1 to 2 seconds after the touch, and then Off

ABS MOTOR

- Touch “On” and “Off” on screen. Make sure motor relay, actuator relay, V/R output and M/R output operate as shown in table below.

Operation	On	Off
MOTOR RELAY	On	Off
ACTUATOR RLY	On	On

TROUBLE DIAGNOSIS FOR SELF-DIAGNOSTIC ITEMS

< SERVICE INFORMATION >

[VDC/TCS/ABS]

TROUBLE DIAGNOSIS FOR SELF-DIAGNOSTIC ITEMS

Wheel Sensor System Inspection

INFOID:000000005612159

INSPECTION PROCEDURE

1.CONNECTOR INSPECTION

Disconnect the ABS actuator and electric unit (control unit) connector E33 and wheel sensor of malfunctioning code.

Check the terminals for deformation, disconnection, looseness or damage.

OK or NG

OK >> GO TO 2.

NG >> Repair or replace as necessary.

2.CHECK WHEEL SENSOR OUTPUT SIGNAL

1. Connect ABS active wheel sensor tester (J-45741) to wheel sensor using appropriate adapter.

2. Turn on the ABS active wheel sensor tester power switch.

NOTE:

The green POWER indicator should illuminate. If the POWER indicator does not illuminate, replace the battery in the ABS active wheel sensor tester before proceeding.

3. Spin the wheel of the vehicle by hand and observe the red SENSOR indicator on the ABS active wheel sensor tester. The red SENSOR indicator should flash on and off to indicate an output signal.

NOTE:

If the red SENSOR indicator illuminates but does not flash, reverse the polarity of the tester leads and retest.

Does the ABS active wheel sensor tester detect a signal?

YES >> GO TO 3.

NO >> Replace the wheel sensor. Refer to [BRC-86. "Removal and Installation"](#).

3.CHECK TIRES

Check for inflation pressure, wear and size of each tire. Refer to [WT-28. "Tire"](#).

Are tire pressure and size correct and is tire wear within specifications?

YES >> GO TO 4.

NO >> Adjust tire pressure or replace tire(s).

4.CHECK WHEEL BEARINGS

Check wheel bearing axial end play. Refer to [FAX-6. "On-Vehicle Inspection and Service"](#) or [RAX-6. "On-Vehicle Inspection and Service"](#).

OK or NG

OK >> GO TO 5.

NG >> Repair or replace as necessary. Refer to [FAX-6. "Removal and Installation"](#) (front) or [RAX-6. "Removal and Installation"](#) (rear).

5.CHECK WIRING HARNESS FOR SHORT CIRCUIT

1. Turn the ignition switch OFF.

2. Disconnect ABS actuator and electric unit (control unit) connector and wheel sensor connector of malfunction code No.

3. Check continuity between wheel sensor harness connector terminals and ground.

Continuity should not exist.

OK or NG

OK >> GO TO 6.

NG >> Repair the circuit.

6.CHECK WIRING HARNESS FOR OPEN CIRCUIT

A
B
C
D
E
BRC
G
H
I
J
K
L
M
N
O
P

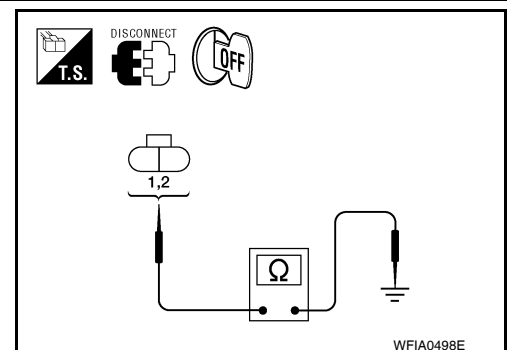

TROUBLE DIAGNOSIS FOR SELF-DIAGNOSTIC ITEMS

< SERVICE INFORMATION >

[VDC/TCS/ABS]

Check continuity between ABS actuator and electric unit (control unit) harness connector and wheel sensor harness connector.

Wheel sensor	ABS actuator and electric unit (control unit)		Wheel sensor		Continuity
	Connector	Terminals	Connector	Terminals	
Front LH	E33	5	E18	1	Yes
		16		2	
Front RH		10	E117	1	
		9		2	
Rear LH		17	B123	1	
		6		2	
Rear RH		19	B122	1	
		8		2	

OK or NG

- OK >> Replace the ABS actuator and electric unit (control unit). Refer to [BRC-89, "Removal and Installation"](#).
- NG >> Repair the circuit.

Engine System Inspection

INFOID:000000005612160

INSPECTION PROCEDURE

1. SELF-DIAGNOSIS RESULT CHECK

Check self-diagnosis results.

Self-diagnosis results
ENGINE SIGNAL 1
ENGINE SIGNAL 2
ENGINE SIGNAL 3
ENGINE SIGNAL 4
ENGINE SIGNAL 6

Is the above displayed in the self-diagnosis display items?

- YES >> GO TO 2.
- NO >> Inspection End.

2. ENGINE SYSTEM INSPECTION

1. Perform ECM self-diagnosis and repair as necessary.
2. Perform ABS actuator and electric unit (control unit) self-diagnosis again.

OK or NG

- OK >> Inspection End.
- NG >> Repair as necessary.

ABS/TCS/VDC Control Unit Inspection

INFOID:000000005612161

INSPECTION PROCEDURE

1. SELF-DIAGNOSIS RESULT CHECK

Check self-diagnosis results.

Self-diagnosis results
CONTROLLER FAILURE

TROUBLE DIAGNOSIS FOR SELF-DIAGNOSTIC ITEMS

< SERVICE INFORMATION >

[VDC/TCS/ABS]

Self-diagnosis results

EMERGENCY BRAKE

VARIANT CODING

Is the above displayed in the self-diagnosis display items?

YES >> GO TO 2.

NO >> Inspection End.

2. CHECK WHEEL SENSORS

Check all wheel sensors. Refer to [BRC-67. "Wheel Sensor System Inspection"](#).

OK or NG

OK >> Replace ABS actuator and electric unit (control unit). Refer to [BRC-89. "Removal and Installation"](#).

NG >> Repair or replace as necessary.

Steering Angle Sensor System Inspection

INFOID:000000005612162

INSPECTION PROCEDURE

1. SELF-DIAGNOSIS RESULT CHECK

Check self-diagnosis results.

Self-diagnosis results

ST ANGLE SEN CIRCUIT

ST ANGLE SEN SIGNAL

Is the above displayed in the self-diagnosis display items?

YES >> GO TO 3.

NO >> GO TO 2.

2. DATA MONITOR CHECK

Conduct "DATA MONITOR" of the "STR ANGLE SIG" to check if the status is normal.

Steering condition	Data monitor
Straight-ahead	-2.5 ° to +2.5°
Turn wheel 90° to the right.	Approx. +90°
Turn wheel 90° to the left.	Approx. -90°

OK or NG

OK >> Inspection End.

NG >> GO TO 3.

3. CONNECTOR INSPECTION

1. Disconnect the ABS actuator and electric unit (control unit) and steering angle sensor connectors.
2. Check the terminals for deformation, disconnection, looseness or damage.

OK or NG

OK >> GO TO 4.

NG >> Repair or replace as necessary.

4. CHECKING STEERING ANGLE SENSOR POWER AND GROUND

A
B
C
D
E
G
H
I
J
K
L
M
N
O
P

BRC

TROUBLE DIAGNOSIS FOR SELF-DIAGNOSTIC ITEMS

[VDC/TCS/ABS]

< SERVICE INFORMATION >

1. Turn the ignition switch ON.
2. Check voltage between steering angle sensor connector M64 terminal 1 and ground.

Steering angle sensor		Ground	Voltage (Approx.)
Connector	Terminal		
M64	1	—	Battery voltage

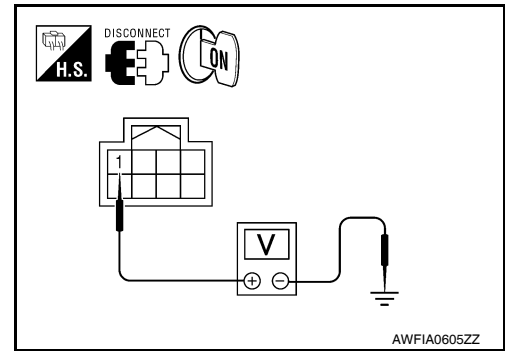

3. Turn the ignition switch OFF.
4. Check resistance between steering angle sensor connector M64 terminal 3 and ground.

Steering angle sensor		Ground	Continuity
Connector	Terminal		
M64	3	Ground	Yes

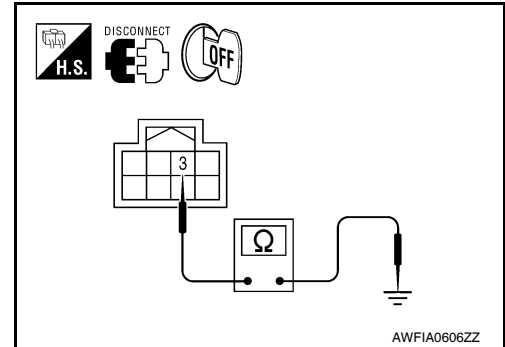

OK or NG

- OK >> Check the CAN communication system. Refer to [BRC-79. "CAN Communication System Inspection"](#). If the CAN communication system is OK, replace steering angle sensor. Refer to [BRC-91. "Removal and Installation"](#).
- NG >> Repair the circuit.

Yaw Rate/Side/Decel G Sensor System Inspection

INFOID:000000005612163

CAUTION:

Sudden turns (such as spin turns, acceleration turns), drifting, etc. When VDC function is OFF may cause the yaw rate/side/decel G sensor system to indicate a problem. However this is not a problem if normal operation can be resumed after restarting the engine.

INSPECTION PROCEDURE

1. SELF-DIAGNOSIS RESULT CHECK

Check self-diagnosis results.

Self-diagnosis results
YAW RATE SENSOR
SIDE G-SEN CIRCUIT

CAUTION:

When on a turntable, such as at a parking structure entrance, or when on a moving object with the engine running, the VDC OFF indicator lamp might turn on and the self-diagnosis using the CONSULT-III the yaw rate sensor system might be displayed, but in this case there is no problem with the yaw rate sensor system. As soon as the vehicle leaves the turntable or moving object, restart the engine to return the system to normal.

Is the above displayed in the self-diagnosis display items?

- YES >> GO TO 2.
NO >> Inspection End.

2. CONNECTOR INSPECTION

Disconnect the ABS actuator and electric unit (control unit) and yaw rate/side/decel G sensor connectors. Check the terminals for deformation, disconnection, looseness or damage.

OK or NG

- OK >> GO TO 3.

TROUBLE DIAGNOSIS FOR SELF-DIAGNOSTIC ITEMS

< SERVICE INFORMATION >

[VDC/TCS/ABS]

NG >> Repair or replace as necessary.

3. CHECK YAW RATE/SIDE/DECEL G SENSOR POWER SUPPLY CIRCUIT

Check voltage between yaw rate/side/decel G sensor connector B3 terminal 4 and ground.

Yaw rate/side/decel G sensor		Ground	Condition	Voltage (Approx.)
Connector	Terminal			
B3	4	—	Ignition switch: ON	Battery voltage
			Ignition switch: OFF	0V

Is the inspection result normal?

YES >> GO TO 4

NO >> Repair or replace malfunctioning components.

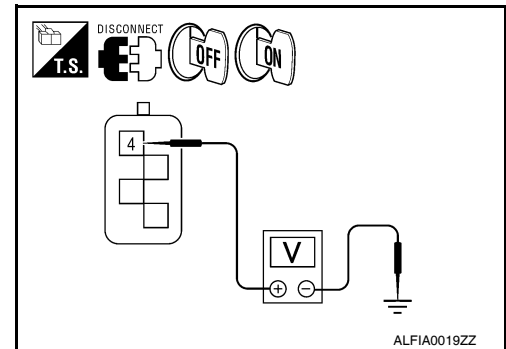

4. CHECK YAW RATE/SIDE/DECEL G SENSOR GROUND SUPPLY CIRCUIT

- Turn ignition switch OFF.
- Check resistance between yaw rate/side/decel G sensor connector B3 terminal 1 and ground.

Yaw rate/side/decel G sensor		Ground	Continuity
Connector	Terminal		
B3	1	—	Yes

Is the inspection result normal?

YES >> GO TO 5

NO >> Repair or replace malfunctioning components.

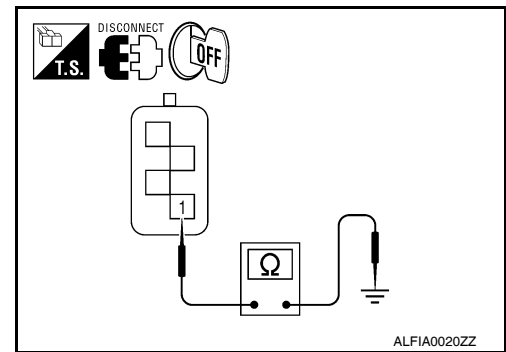

5. CHECK YAW RATE/SIDE/DECEL G SENSOR HARNESS

- Check continuity between ABS actuator and electric unit (control unit) connector E33 (A) terminals 14 and 25 and yaw rate/side/decel G sensor connector B3 (B) terminals 2 and 3.

ABS actuator and electric unit (control unit)		Yaw rate/side/decel G sensor		Continuity
Connector	Terminal	Connector	Terminal	
E33 (A)	14	B3 (B)	2	Yes
	25		3	

- Check continuity between ABS actuator and electric unit (control unit) connector E33 (A) terminals 14, 25 and ground.

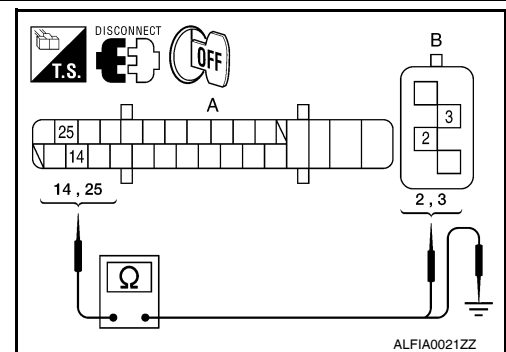

ABS actuator and electric unit (control unit)		Ground	Continuity
Connector	Terminal		
E33 (A)	14	—	No
	25		

Is the inspection result normal?

YES >> GO TO 6

NO >> Repair or replace malfunctioning components.

6. CHECK DATA MONITOR

- Connect Yaw rate/side/decel G sensor and ABS actuator and electric unit (control unit) connectors.

A
B
C
D
E
BRC
G
H
I
J
K
L
M
N
O
P

TROUBLE DIAGNOSIS FOR SELF-DIAGNOSTIC ITEMS

< SERVICE INFORMATION >

[VDC/TCS/ABS]

2. Select "YAW RATE SEN", "SIDE G-SENSOR" in "Data Monitor" and check Yaw rate/side/decel G sensor signal.

Vehicle condition	Yaw rate sensor (Data monitor)	Side G sensor (Data monitor)
Stopped	Approx. 0 d/s	Approx. 0 m/s ²
Turning right	Negative value	Negative value
Turning left	Positive value	Positive value

Is the inspection result normal?

YES >> Replace ABS actuator and electric unit (control unit). Refer to [BRC-89. "Removal and Installation"](#).

NO >> Replace Yaw rate/side/decel G sensor. Refer to [BRC-92. "Removal and Installation"](#).

Solenoid and VDC Change-Over Valve System Inspection

INFOID:000000005612164

INSPECTION PROCEDURE

1. SELF-DIAGNOSIS RESULT CHECK

Check self-diagnosis results.

Self-diagnosis results
FR LH IN ABS SOL
FR LH OUT ABS SOL
RR RH IN ABS SOL
RR RH OUT ABS SOL
FR RH IN ABS SOL
FR RH OUT ABS SOL
RR LH IN ABS SOL
RR LH OUT ABS SOL
USV LINE [FL-RR]
USV LINE [FR-RL]
HSV LINE [FL-RR]
HSV LINE [FR-RL]
MAIN RELAY

Is the above displayed in the self-diagnosis display items?

YES >> GO TO 2.

NO >> Inspection End.

2. CONNECTOR INSPECTION

1. Disconnect ABS actuator and electric unit (control unit) connector.
2. Check the terminals for deformation, disconnection, looseness or damage.

OK or NG

OK >> GO TO 3.

NG >> Repair or replace as necessary.

3. CHECKING SOLENOID POWER AND GROUND

TROUBLE DIAGNOSIS FOR SELF-DIAGNOSTIC ITEMS

< SERVICE INFORMATION >

[VDC/TCS/ABS]

1. Check voltage between ABS actuator and electric unit (control unit) harness connector E33 and body ground.

ABS actuator and electric unit (control unit) harness connector E33	Body ground	Measured value (Approx.)
3	—	12V

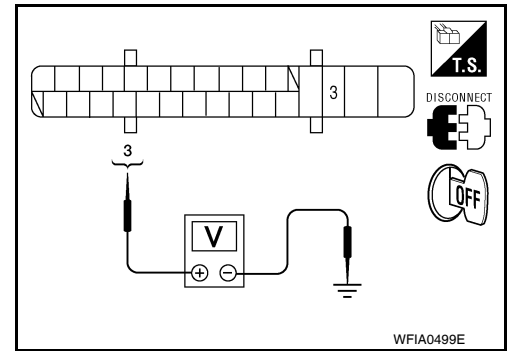

2. Check resistance between ABS actuator and electric unit (control unit) harness connector E33 and body ground.

ABS actuator and electric unit (control unit) harness connector E33	Body ground	Measured value (Approx.)
4	—	0Ω

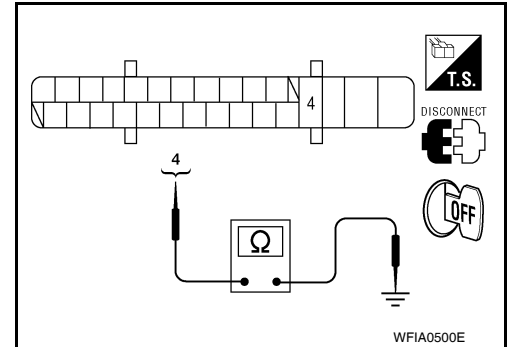

OK or NG

- OK >> Perform self-diagnosis again. If the same results appear, replace ABS actuator and electric unit (control unit). Refer to [BRC-89, "Removal and Installation"](#).
- NG >> Repair the circuit.

Actuator Motor, Motor Relay, and Circuit Inspection

INFOID:000000005612165

INSPECTION PROCEDURE

1. CHECKING SELF-DIAGNOSIS RESULTS

Check self-diagnosis results.

Self-diagnosis results
PUMP MOTOR

Is the above displayed in the self-diagnosis display items?

- YES >> GO TO 2.
 NO >> Inspection End.

2. CONNECTOR INSPECTION

Disconnect the ABS actuator and electric unit (control unit) connector. Check the terminals for deformation, disconnection, looseness or damage.

OK or NG

- OK >> GO TO 3.
 NG >> Repair or replace as necessary.

3. CHECKING ABS MOTOR AND MOTOR RELAY POWER SYSTEM

1. Check voltage between ABS actuator and electric unit (control unit) harness connector E33 and ground.

ABS actuator and electric unit (control unit) harness connector E33	Body ground	Measured value (Approx.)
2	—	12V

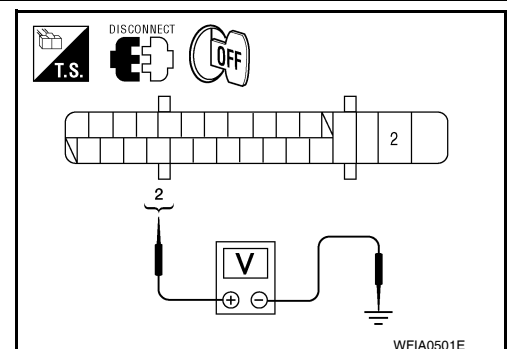

A
B
C
D
E
BRC
G
H
I
J
K
L
M
N
O
P

TROUBLE DIAGNOSIS FOR SELF-DIAGNOSTIC ITEMS

< SERVICE INFORMATION >

[VDC/TCS/ABS]

- Check resistance between ABS actuator and electric unit (control unit) connector E33 and ground.

ABS actuator and electric unit (control unit) harness connector E33	Body ground	Measured value (Approx.)
1	—	0Ω

OK or NG

- OK >> Perform self-diagnosis again. If the same results appear, replace ABS actuator and electric unit (control unit). Refer to [BRC-89, "Removal and Installation"](#).
- NG >> Repair the circuit.

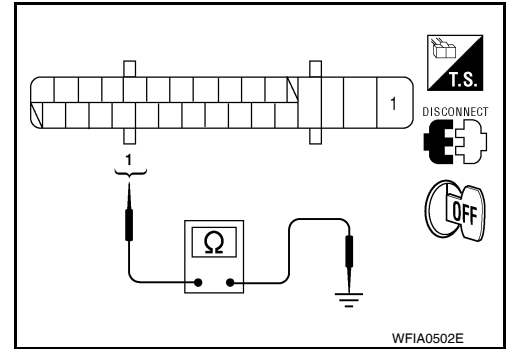

Stop Lamp Switch System Inspection

INFOID:000000005612166

INSPECTION PROCEDURE

1. SELF-DIAGNOSIS RESULT CHECK

Check self-diagnosis results.

Self-diagnosis results
STOP LAMP SW

Is the above displayed in the self-diagnosis display items?

- YES >> GO TO 2.
- NO >> Inspection End.

2. CONNECTOR INSPECTION

- Disconnect the ABS actuator and electric unit (control unit) and stop lamp switch connectors.
- Check the terminals for deformation, disconnection, looseness or damage.

OK or NG

- OK >> GO TO 3.
- NG >> Repair or replace as necessary.

3. CHECK STOP LAMP SWITCH CIRCUIT

- Connect stop lamp switch connector.
- Check voltage between ABS actuator and electric unit (control unit) connector E33 terminal 20 and ground.

ABS actuator and electric unit (control unit)		Ground	Condition	Voltage (Approx.)
Connector	Terminal			
E33	20	—	Brake pedal depressed	Battery voltage
			Brake pedal released	0V

Is the inspection result normal?

- YES >> Replace ABS actuator and electric unit (control unit). Refer to [BRC-89, "Removal and Installation"](#).
- NO >> GO TO 4

4. CHECK STOP LAMP SWITCH CIRCUIT FOR OPEN

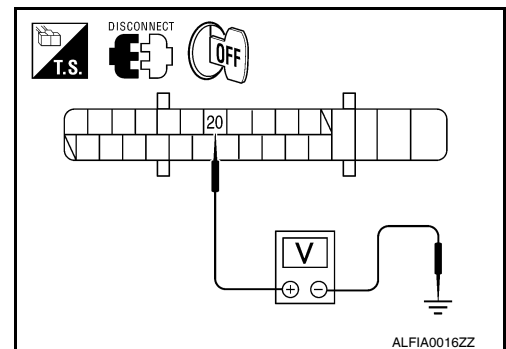

TROUBLE DIAGNOSIS FOR SELF-DIAGNOSTIC ITEMS

< SERVICE INFORMATION >

[VDC/TCS/ABS]

1. Disconnect stop lamp switch connector.
2. Check continuity between ABS actuator and electric unit (control unit) connector E33 (A) terminal 20 and stop lamp switch connector E13 (B) terminal 2 (without M/T), or E13 (C) terminal 2 (with M/T).

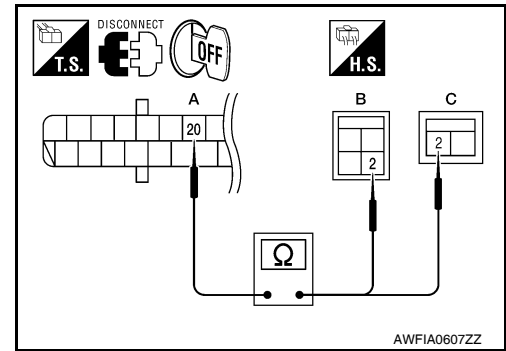

ABS actuator and electric unit (control unit)		stop lamp switch		Continuity
Connector	Terminal	Connector	Terminal	
E33 (A)	20	E13 (B) (without M/T)	2	Yes
		E13 (C) (with M/T)		

Is the inspection result normal?

- YES >> GO TO 5.
 NO >> Repair or replace as necessary.

5. CHECK STOP LAMP SWITCH CIRCUIT FOR SHORT

Check continuity between ABS actuator and electric unit (control unit) connector E33 terminal 20 and ground.

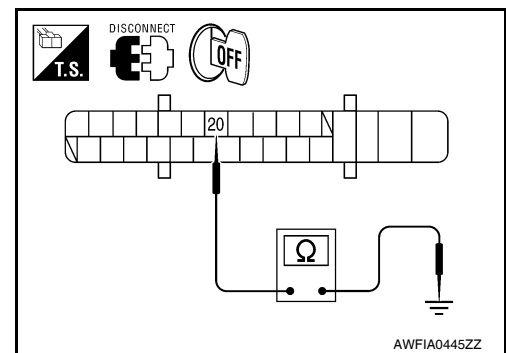

ABS actuator and electric unit (control unit)		Ground	Continuity
Connector	Terminal		
E33	20	—	No

Is the inspection result normal?

- YES >> Replace stop lamp switch.
 NO >> Repair harness or connectors.

ABS/TCS/VDC Control Unit Power and Ground Systems Inspection

INFOID:000000005612167

INSPECTION PROCEDURE

1. SELF-DIAGNOSIS RESULT CHECK

Check self-diagnosis results.

Self-diagnosis results
BATTERY VOLTAGE

Is the above displayed in the self-diagnosis display items?

- YES >> GO TO 2.
 NO >> Inspection End.

2. CONNECTOR INSPECTION

1. Disconnect the ABS actuator and electric unit (control unit) connector.
2. Check the terminals for deformation, disconnection, looseness or damage.

OK or NG

- OK >> GO TO 3.
 NG >> Repair or replace as necessary.

3. ABS/TCS/VDC CONTROL UNIT POWER AND GROUND CIRCUIT INSPECTION

Measure the voltage and continuity between the ABS actuator and electric unit (control unit) connector E33 and ground.

Signal name	ABS actuator and electric unit (control unit) connector E33	Ground	Measured value
-------------	---	--------	----------------

TROUBLE DIAGNOSIS FOR SELF-DIAGNOSTIC ITEMS

< SERVICE INFORMATION >

[VDC/TCS/ABS]

Power supply	2	—	Battery voltage (Approx. 12V)
	3		
Ground	1		Continuity should exist.
	4		

OK or NG

- OK >> Check the battery for loose terminals, low voltage, etc. Repair as necessary.
- NG >> Repair the circuit.

Brake Fluid Level Switch System Inspection

INFOID:000000005612168

INSPECTION PROCEDURE

1. SELF-DIAGNOSIS RESULT CHECK

1. Check the brake reservoir tank fluid level. If the level is low, add brake fluid.
2. Erase the self-diagnosis results and check the self-diagnosis results.

Self-diagnosis results
BR FLUID LEVEL LOW

Is the above displayed in the self-diagnosis display items?

- YES >> GO TO 2.
- NO >> Inspection End.

2. CONNECTOR INSPECTION

1. Disconnect the ABS actuator and electric unit (control unit) and brake fluid level switch connectors.
2. Check the terminals for deformation, disconnection, looseness or damage.

OK or NG

- OK >> GO TO 3.
- NG >> Repair or replace as necessary.

3. CHECK BRAKE FLUID LEVEL SWITCH

1. Turn ignition switch OFF.
2. Check continuity between brake fluid level switch terminals 1 and 2.

Brake fluid level switch terminals	Condition	Continuity
1—2	Brake fluid reservoir full	No
	Brake fluid reservoir empty	Yes

Is the inspection result normal?

- YES >> GO TO 4
- NO >> Replace brake fluid level switch.

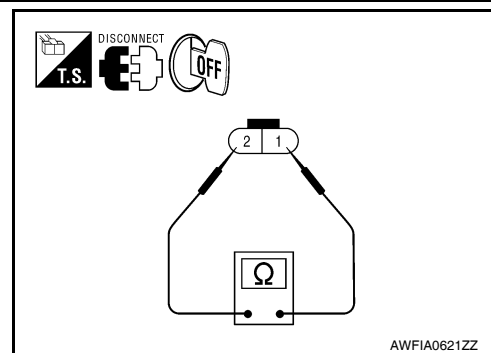

4. CHECK BRAKE FLUID LEVEL SWITCH HARNESS

1. Disconnect combination meter connector.
2. Check continuity between combination meter connector M24 (A) terminal 25 and brake fluid level switch connector E40 (B) terminal 1.

25 - 1 : Continuity should exist.

3. Check continuity between combination meter connector M24 (A) terminal 25 and ground.

25 - Ground : Continuity should not exist.

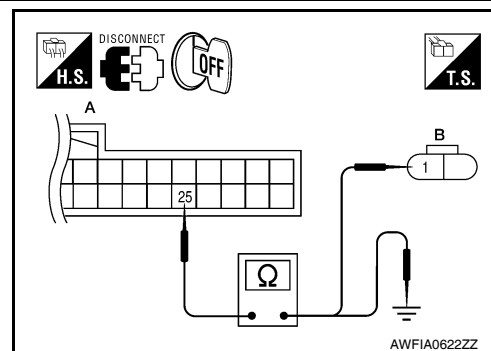

Is the inspection result normal?

TROUBLE DIAGNOSIS FOR SELF-DIAGNOSTIC ITEMS

< SERVICE INFORMATION >

[VDC/TCS/ABS]

- YES >> GO TO 5
- NO >> Repair or replace malfunctioning components.

5.CHECK BRAKE FLUID LEVEL SWITCH GROUND CIRCUIT

Check continuity between brake fluid level switch connector E40 (B) terminal 2 and ground.

2 - Ground : Continuity should exist.

Is the inspection result normal?

- YES >> Inspection End.
- NO >>
 - Repair or replace malfunctioning components.
 - Perform the self-diagnosis, and make sure that the result shows "NO DTC IS DETECTED".

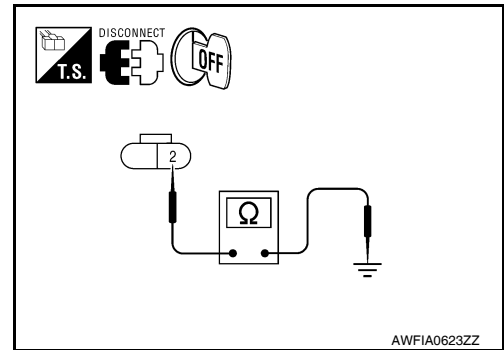

Pressure Sensor System Inspection

INFOID:000000005612169

INSPECTION PROCEDURE

1.SELF-DIAGNOSIS RESULT CHECK

Check the self-diagnosis results.

Self-diagnosis results

PRESS SEN CIRCUIT

Is the above displayed in the self-diagnosis display items?

- YES >> GO TO 2.
- NO >> Inspection End.

2.CONNECTOR INSPECTION

1. Turn ignition switch OFF.
2. Disconnect ABS actuator and electric unit (control unit) connector and stop lamp switch connector.
3. Check terminals for deformation, disconnection, looseness and damage. If any malfunction is found, repair or replace terminals.
4. Reconnect connectors securely.
5. Start engine.
6. Pump brake pedal carefully several times, and perform self-diagnosis.

Is the inspection result normal?

- YES >> GO TO 3
- NO >> Poor connection of connector terminal. Repair or replace connector.

3.CHECK STOP LAMP SWITCH

A
B
C
D
E
BRC
G
H
I
J
K
L
M
N
O
P

TROUBLE DIAGNOSIS FOR SELF-DIAGNOSTIC ITEMS

[VDC/TCS/ABS]

< SERVICE INFORMATION >

1. Turn ignition switch OFF.
2. Disconnect stop lamp switch connector.
3. Check continuity between stop lamp switch (A) (without M/T) or (B) (with M/T) terminals 1 and 2.

Stop lamp switch terminals	Condition	Continuity
1 – 2	Brake pedal depressed	Yes
	Brake pedal released	No

Is the inspection result normal?

- YES >> GO TO 4
 NO >> Replace stop lamp switch.

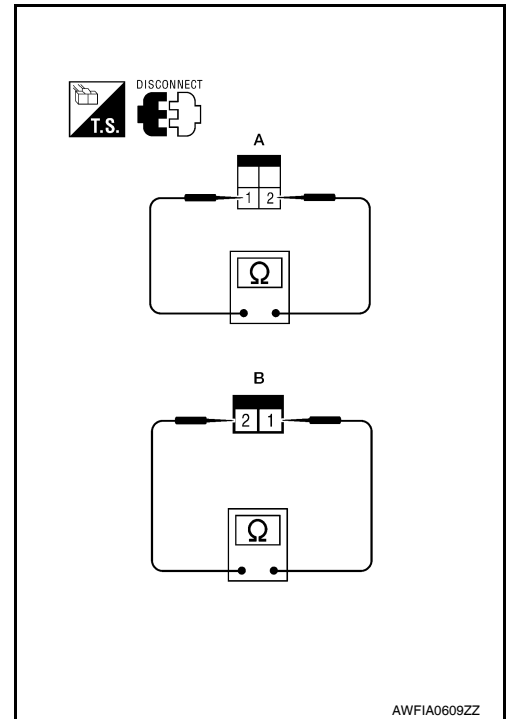

4. CHECK STOP LAMP SWITCH CIRCUIT

1. Disconnect ABS actuator and electric unit (control unit) connector.
2. Connect stop lamp switch connector.
3. Check voltage between ABS actuator and electric unit (control unit) connector E33 terminal 20 and ground.

ABS actuator and electric unit (control unit)		Ground	Condition	Voltage (Approx.)
Connector	Terminal			
E33	20	—	Brake pedal depressed	Battery voltage
			Brake pedal released	0V

Is the inspection result normal?

- YES >> GO TO 5
 NO >> Repair or replace malfunctioning components.

5. CHECK DATA MONITOR

On "DATA MONITOR", select "PRESS SENSOR" and check the brake fluid pressure.

Condition	PRESS SENSOR (DATA MONITOR)
With ignition switch turned ON and brake pedal released.	Approx. 0 bar
With ignition switch turned ON and brake pedal depressed.	– 40 to 300 bar

Is the inspection result normal?

- YES >> Replace ABS actuator and electric unit (control unit). Refer to [BRC-89. "Removal and Installation"](#).
 NO >> Inspection End.

Transmission Range Switch System Inspection

INFOID:000000005612170

INSPECTION PROCEDURE

1. SELF-DIAGNOSIS RESULT CHECK

TROUBLE DIAGNOSIS FOR SELF-DIAGNOSTIC ITEMS

< SERVICE INFORMATION >

[VDC/TCS/ABS]

Check the self-diagnosis results.

Self-diagnosis results

PNP POS SIG

Is the above displayed in the self-diagnosis display items?

YES >> GO TO 2.

NO >> Inspection End.

2.CONNECTOR INSPECTION

1. Disconnect the ABS actuator and electric unit (control unit) and brake fluid level switch connectors.
2. Check the terminals for deformation, disconnection, looseness or damage.

OK or NG

OK >> GO TO 3.

NG >> Repair or replace as necessary.

3.CHECK TRANSMISSION RANGE SWITCH

Perform transmission range switch inspection. Refer to [AT-94, "Component Inspection"](#) (with A/T) or [CVT-65, "Component Inspection"](#) (with CVT).

Is the inspection result normal?

YES >> Replace ABS actuator and electric unit (control unit). Refer to [BRC-89, "Removal and Installation"](#).

NO >> Repair or replace malfunctioning components.

CAN Communication System Inspection

INFOID:000000005612171

INSPECTION PROCEDURE

1.SELF-DIAGNOSIS RESULT CHECK

Check the self-diagnosis results.

Self-diagnosis results

ST ANG SEN COM CIR

CAN COMM CIRCUIT

Is the above displayed in the self-diagnosis display items?

YES >> GO TO 2.

NO >> Inspection End.

2.CHECK CONNECTOR

1. Disconnect the ABS actuator and electric unit (control unit) connector, and check the terminals for deformation, disconnection, looseness, and so on. If there is a malfunction, repair or replace the terminals.
2. Reconnect connector to perform self-diagnosis. Refer to [BRC-60, "CONSULT-III Function \(ABS\)"](#).

Is "CAN COMM CIRCUIT" displayed in the self-diagnosis display items?

YES >> Refer to [LAN-17, "Trouble Diagnosis Flow Chart"](#).

NO >> Connector terminal connection is loose, damaged, open, or shorted.

Component Inspection

INFOID:000000005612172

VDC OFF SWITCH

TROUBLE DIAGNOSIS FOR SELF-DIAGNOSTIC ITEMS

< SERVICE INFORMATION >

[VDC/TCS/ABS]

Check the continuity between terminals 1 and 2.

- 1 -2 : Continuity should exist when pushing the switch.**
Continuity should not exist when releasing the switch.

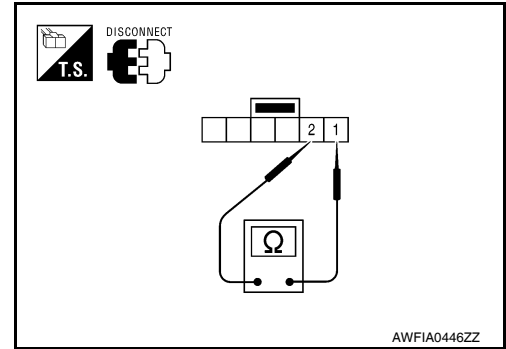

PARKING BRAKE SWITCH

1. CHECK PARKING BRAKE SWITCH

1. Turn ignition switch OFF.
2. Disconnect parking brake switch connector.
3. Check continuity between parking brake switch terminal 1 and ground.

Component	Terminal	Condition	Continuity
Parking brake switch	1	Parking brake applied	Yes
		Parking brake released	No

Is the inspection result normal?

- YES >> Inspection End.
 NO >> Replace parking brake switch.

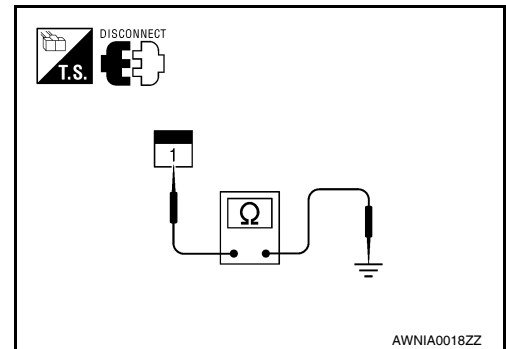

TROUBLE DIAGNOSES FOR SYMPTOMS

< SERVICE INFORMATION >

[VDC/TCS/ABS]

TRouble DIAGNOSES FOR SYMPTOMS

ABS Works Frequently

INFOID:000000005612173

1. CHECK WARNING LAMP ACTIVATION

Make sure warning lamp remains off while driving.

OK or NG

OK >> GO TO 2.

NG >> Carry out self-diagnosis. Refer to [BRC-60. "CONSULT-III Function \(ABS\)"](#).

2. CHECK WHEEL SENSORS

Check the following.

- Wheel sensor mounting for looseness
- Wheel sensors for physical damage
- Wheel sensor connectors for terminal damage or loose connections

OK or NG

OK >> GO TO 3.

NG >> Repair as necessary.

3. CHECK WHEEL BEARINGS

Check wheel bearing axial end play. Refer to [FAX-6. "On-Vehicle Inspection and Service"](#) or [RAX-6. "On-Vehicle Inspection and Service"](#).

OK or NG

OK >> GO TO 4.

NG >> Repair as necessary.

4. CHECK BRAKE FLUID PRESSURE

Check brake fluid pressure distribution.

Refer to [BR-9. "On Board Inspection"](#).

Is brake fluid pressure distribution normal?

YES >> Inspection End.

NO >> Perform Basic Inspection. Refer to [BRC-56. "Basic Inspection"](#).

Unexpected Pedal Action

INFOID:000000005612174

1. CHECK WARNING LAMP ACTIVATION

Make sure warning lamp remains off while driving.

OK or NG

OK >> GO TO 2.

NG >> Carry out self-diagnosis. Refer to [BRC-60. "CONSULT-III Function \(ABS\)"](#).

2. CHECK BRAKE PEDAL STROKE

Check brake pedal stroke.

Is pedal stroke excessive?

YES >> Perform Basic Inspection. Refer to [BRC-56. "Basic Inspection"](#).

NO >> GO TO 3.

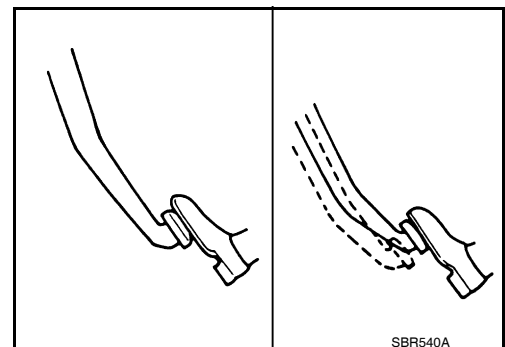

TROUBLE DIAGNOSES FOR SYMPTOMS

< SERVICE INFORMATION >

[VDC/TCS/ABS]

3. CHECK CONNECTOR AND BRAKING PERFORMANCE

1. Disconnect ABS actuator and electric unit (control unit) connector.
2. Check brake effectiveness.

NOTE:

Driving the vehicle with the ABS actuator and electric unit (control unit) disconnected may induce DTCs in electrical control units using CAN communication. After the inspection, clear all DTCs. Refer to [BRC-60, "CONSULT-III Function \(ABS\)"](#).

OK or NG

- OK >> GO TO 4.
NG >> Perform Basic Inspection. Refer to [BRC-56, "Basic Inspection"](#).

4. CHECK WHEEL SENSORS

Check the following.

- Wheel sensor mounting for looseness
- Wheel sensors for physical damage
- Wheel sensor connectors for terminal damage or loose connections

OK or NG

- OK >> Check ABS actuator and electric unit (control unit) pin terminals for damage and the connection of harness connector. Reconnect ABS actuator and electric unit (control unit) harness connector. Then retest.
NG >> Repair as necessary.

Long Stopping Distance

INFOID:000000005612175

1. CHECK BASE BRAKING SYSTEM PERFORMANCE

1. Disable ABS by disconnecting ABS actuator and electric unit (control unit) connector.
2. Drive vehicle and check to see if stopping distance is still long.

NOTE:

Driving the vehicle with the ABS actuator and electric unit (control unit) disconnected may induce DTCs in electrical control units using CAN communication. After the inspection, clear all DTCs. Refer to [BRC-60, "CONSULT-III Function \(ABS\)"](#).

OK or NG

- OK >> Go to [BRC-81, "ABS Works Frequently"](#).
NG >> Perform Basic Inspection. Refer to [BRC-56, "Basic Inspection"](#).

NOTE:

Stopping distance may be longer than vehicles without ABS when road condition is slippery.

ABS Does Not Work

INFOID:000000005612176

CAUTION:

The ABS does not operate when the vehicle speed is 10 km/h (6 MPH) or less.

1. CHECK WARNING LAMP ACTIVATION

Turn ignition switch ON and check for warning lamp activation.

- Warning lamp should activate for approximately 2 seconds after turning the ignition switch ON.

OK or NG

- OK >> Carry out self-diagnosis. Refer to [BRC-60, "CONSULT-III Function \(ABS\)"](#).
NG >> Go to [BRC-83, "ABS Warning Lamp Does Not Come On When Ignition Switch Is Turned On"](#).

Pedal Vibration or ABS Operation Noise

INFOID:000000005612177

NOTE:

During ABS activation, pedal vibration may be felt and a noise may be heard. This is normal and does not indicate a malfunction.

TROUBLE DIAGNOSES FOR SYMPTOMS

< SERVICE INFORMATION >

[VDC/TCS/ABS]

1. CHECK SYMPTOM

1. Apply brake.
2. Start engine.

Does the symptom occur only when engine is started?

- YES >> Carry out self-diagnosis. Refer to [BRC-60. "CONSULT-III Function \(ABS\)"](#).
NO >> GO TO 2.

2. RECHECK SYMPTOM

Does the symptom occur only when electrical equipment switches (such as headlamp) are turned on?

- YES >> Check for radio, antenna or related wiring that is routed too close to the ABS actuator and electric unit (control unit) and reroute as necessary.
NO >> Go to [BRC-81. "ABS Works Frequently"](#).

ABS Warning Lamp Does Not Come On When Ignition Switch Is Turned On

INFOID:000000005612178

BRC

1. CHECK ABS ACTUATOR AND ELECTRIC UNIT (CONTROL UNIT) FUSES

Check 40A fusible link **f** and 30A fusible link **k** for ABS actuator and electric unit (control unit).

OK or NG

- OK >> GO TO 2.
NG >> If fusible link is blown, be sure to eliminate cause of problem before replacing.

2. CHECK ABS ACTUATOR AND ELECTRIC UNIT (CONTROL UNIT) POWER SUPPLY CIRCUITS

1. Disconnect ABS actuator and electric unit (control unit) connector.
2. Check voltage between ABS actuator and electric unit (control unit) connector E33 terminals 2, 3 and ground.

Does battery voltage exist?

- YES >> GO TO 3.
NO >> Repair harness or connectors between fusible link and ABS actuator and electric unit (control unit).

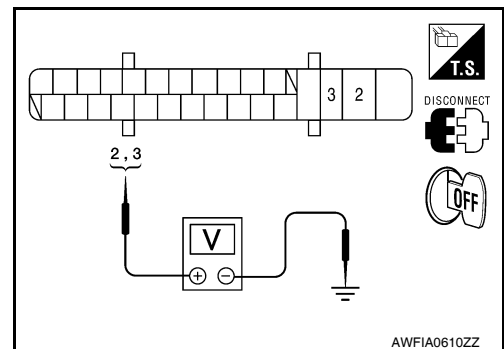

3. CHECK ABS ACTUATOR AND ELECTRIC UNIT (CONTROL UNIT) GROUND CIRCUIT

Check continuity between ABS actuator and electric unit (control unit) connector E33 terminals 1, 4 and ground.

Does continuity exist?

- YES >> Replace ABS actuator and electric unit (control unit). Refer to [BRC-89. "Removal and Installation"](#).
NO >> Repair harness or connectors between ABS actuator and electric unit (control unit) and ground.

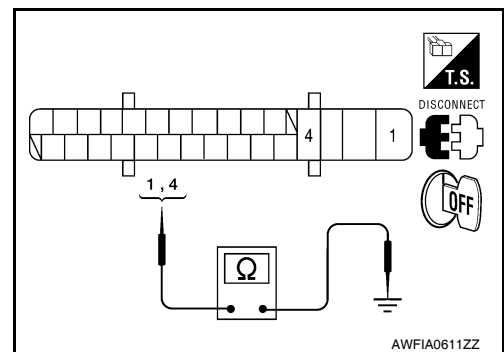

ABS Warning Lamp Stays On When Ignition Switch Is Turned On

INFOID:000000005612179

1. CARRY OUT SELF-DIAGNOSIS

Carry out self-diagnosis. Refer to [BRC-60. "CONSULT-III Function \(ABS\)"](#).

Are malfunctions detected in self-diagnosis?

TROUBLE DIAGNOSES FOR SYMPTOMS

< SERVICE INFORMATION >

[VDC/TCS/ABS]

YES >> Refer to [BRC-60. "CONSULT-III Function \(ABS\)".](#)

NO >> Refer to [DI-21. "Schematic".](#)

Vehicle Jerks During TCS/VDC Activation

INFOID:000000005612180

1. ABS ACTUATOR AND ELECTRIC UNIT (CONTROL UNIT) SELF-DIAGNOSIS

Perform ABS actuator and electric unit (control unit) self-diagnosis.

Are self-diagnosis result items displayed?

YES >> After checking and repairing the applicable item, perform the ABS actuator and electric unit (control unit) self-diagnosis again.

NO >> GO TO 2.

2. ENGINE SPEED SIGNAL INSPECTION

Perform data monitor with CONSULT-III for the ABS actuator and electric unit (control unit).

Is the engine speed at idle 400 rpm or higher?

YES >> GO TO 4.

NO >> GO TO 3.

3. ECM SELF-DIAGNOSIS

Perform ECM self-diagnosis.

Are self-diagnosis result items displayed?

YES >> After checking and repairing the applicable item, perform the ECM self-diagnosis again.

NO >> GO TO 4.

4. TCM SELF-DIAGNOSIS

Perform TCM self-diagnosis.

Are self-diagnosis result items displayed?

YES >> After checking and repairing the applicable item, perform the TCM self-diagnosis again.

NO >> GO TO 5.

5. CONNECTOR INSPECTION

Disconnect the ABS actuator and electric unit (control unit) connector and the ECM connectors and check the terminals for deformation, disconnection, looseness or damage.

OK or NG

OK >> GO TO 6.

NG >> Repair or replace the connector terminal.

6. CAN COMMUNICATION INSPECTION

Check the CAN communication system. Refer to [BRC-79. "CAN Communication System Inspection".](#)

OK or NG

OK >> Inspection End.

NG >> Reconnect the connectors, and perform ABS actuator and electric unit (control unit) self-diagnosis.

ON-VEHICLE SERVICE

Adjustment of Steering Angle Sensor Neutral Position

INFOID:000000005612181

After removing/installing or replacing ABS actuator and electric unit (control unit), steering angle sensor, steering and suspension components which affect wheel alignment or after adjusting wheel alignment, be sure to adjust neutral position of steering angle sensor before running vehicle.

NOTE:

Adjustment of steering angle sensor neutral position requires CONSULT-III.

1. Stop vehicle with front wheels in straight-ahead position.
2. Connect CONSULT-III to data link connector on vehicle, and turn ignition switch ON (do not start engine).
3. Touch "ABS", "WORK SUPPORT" and "ST ANGLE SENSOR ADJUSTMENT" on CONSULT-III screen in this order.
4. Touch "START".

CAUTION:

Do not touch steering wheel while adjusting steering angle sensor.

5. After approximately 10 seconds, touch "END". (After approximately 60 seconds, it ends automatically.)
6. Turn ignition switch OFF, then turn it ON again.
7. Run vehicle with front wheels in straight-ahead position, then stop.
8. Select "DATA MONITOR", "SELECTION FROM MENU", and "STR ANGLE SIG" on CONSULT-III screen. Then check that "STR ANGLE SIG" is within 0 ± 2.5 deg. If value is more than specification, repeat steps 1 to 5.
9. Erase memory of ABS actuator and electric unit (control unit) and ECM.
10. Turn ignition switch to OFF.

A

B

C

D

E

BRC

G

H

I

J

K

L

M

N

O

P

WHEEL SENSORS

< SERVICE INFORMATION >

[VDC/TCS/ABS]

WHEEL SENSORS

Removal and Installation

INFOID:000000005612257

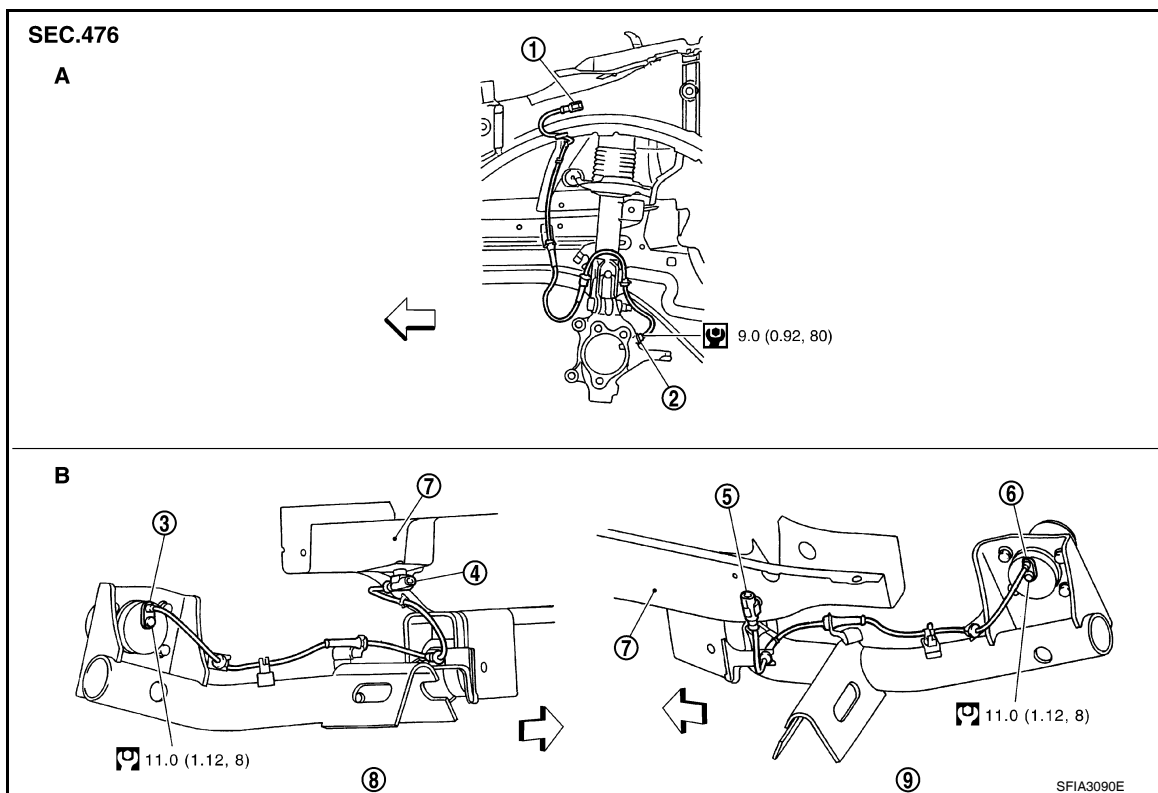

- | | | |
|-------------------------------------|---------------------------|--------------------------------------|
| A. Front | B. Rear | 1. Front wheel sensor connector (LH) |
| 2. Front wheel sensor (LH) | 3. Rear wheel sensor (LH) | 4. Rear wheel sensor connector (LH) |
| 5. Rear wheel sensor connector (RH) | 6. Rear wheel sensor (RH) | 7. Side member |
| 8. LH side | 9. RH side | ⇐ Front |

NOTE:

The top portion of the figure (front side) shows the view from LH side of the vehicle. The RH side is the mirror image of the LH side.

FRONT WHEEL SENSOR

Removal

CAUTION:

- As much as possible, avoid rotating wheel sensor when removing it. Pull wheel sensors out without pulling on sensor harness.
- Take care to avoid damaging wheel sensor edges or rotor teeth. Remove wheel sensor first before removing front or rear wheel hub. This is to avoid damage to wheel sensor wiring and loss of sensor function.

1. Remove the front wheel and tire. Refer to [WT-7, "Adjustment"](#).
2. Remove the front fender protector. Refer to [EI-24, "Removal and Installation"](#).
3. Disconnect the front wheel sensor connector.
4. Remove the front wheel sensor.

Installation

Installation is in the reverse order of removal.

CAUTION:

- When installing, make sure there is no foreign material such as iron chips on and in the mounting hole of the wheel sensor. Make sure no foreign material has been caught in the sensor rotor. Remove any foreign material and clean the mount.

WHEEL SENSORS

< SERVICE INFORMATION >

[VDC/TCS/ABS]

- When installing front wheel sensor, press rubber grommets of strut bracket and body all the way in until they get locked, and be careful not to apply a twist to harness. Harness should not be twisted after installation. (Install it with harness paint mark on body side grommet facing front of vehicle, and the strut side grommet facing outside of vehicle.)

A

REAR WHEEL SENSOR

B

Removal

CAUTION:

- As much as possible, avoid rotating wheel sensor when removing it. Pull wheel sensors out without pulling on sensor harness.
- Take care to avoid damaging wheel sensor edges or rotor teeth. Remove wheel sensor first before removing front or rear wheel hub. This is to avoid damage to wheel sensor wiring and loss of sensor function.

C

1. Disconnect the rear wheel sensor connector.
2. Remove the rear wheel sensor.

D

E

Installation

Installation is in the reverse order of removal.

CAUTION:

- When installing, make sure there is no foreign material such as iron chips on and in the mounting hole of the wheel sensor. Make sure no foreign material has been caught in the sensor rotor. Remove any foreign material and clean the mount.
- When installing rear wheel sensor, press rubber grommets of suspension arm bracket and harness of side member all the way in until they get locked, and be careful not to apply a twist to harness. Harness should not be twisted after installation. (Aim the paint mark upward of vehicle.)

BRC

G

H

I

J

K

L

M

N

O

P

SENSOR ROTOR

Removal and Installation

INFOID:000000005612258

The front and rear sensor rotors are part of the hub and bearing assembly and cannot be removed separately. To replace the front or rear sensor rotors, the hub and bearing assembly must be replaced. Refer to [FAX-6, "Removal and Installation"](#) (front axle), [RAX-6, "Removal and Installation"](#) (rear axle).

ACTUATOR AND ELECTRIC UNIT (ASSEMBLY)

< SERVICE INFORMATION >

[VDC/TCS/ABS]

ACTUATOR AND ELECTRIC UNIT (ASSEMBLY)

Removal and Installation

INFOID:000000005612259

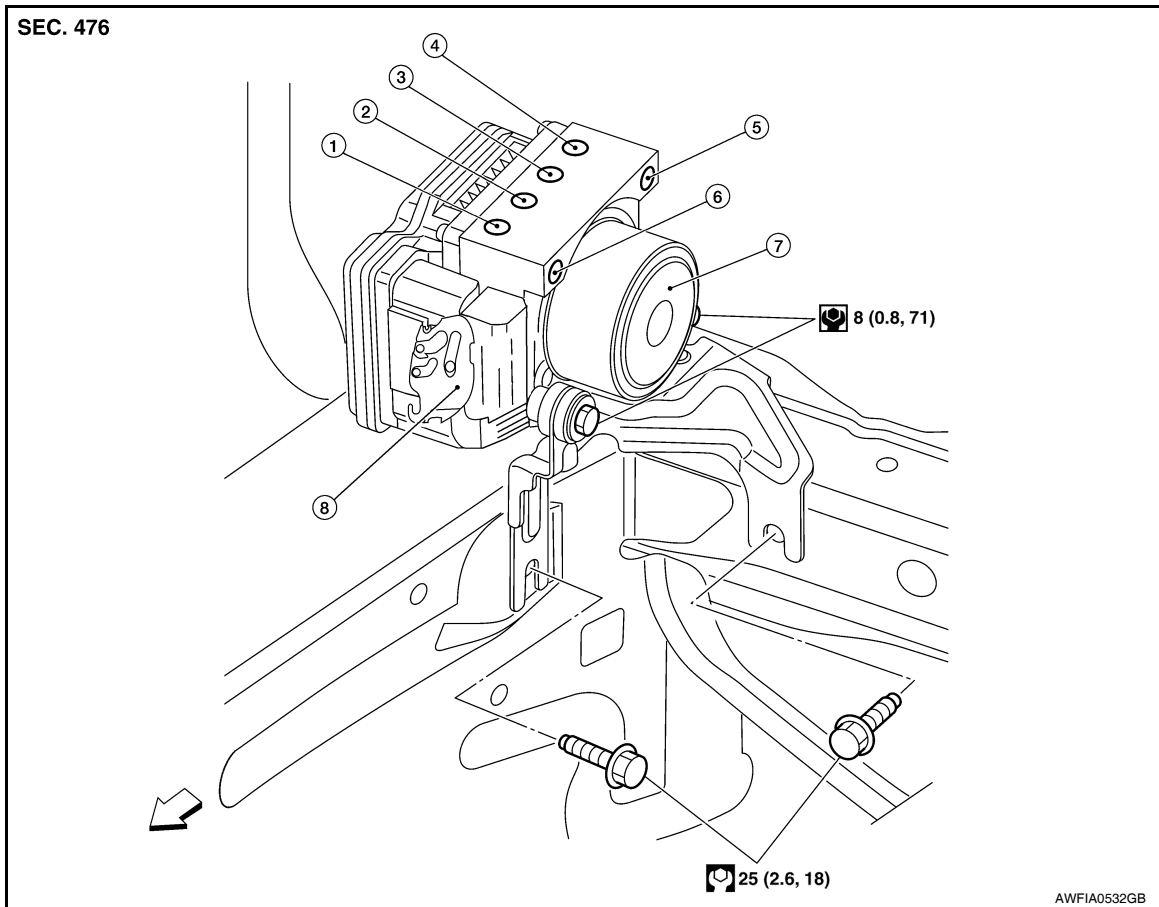

- | | | |
|--|--------------------------------------|--|
| 1. To front right caliper | 2. To rear left wheel cylinder | 3. To rear right wheel cylinder |
| 4. To front left caliper | 5. From master cylinder primary side | 6. From master cylinder secondary side |
| 7. ABS actuator and electric unit (control unit) | 8. Harness connector | ↔ Front |

CAUTION:

- Before servicing, disconnect battery negative terminal.
- To remove brake tube, use flare nut wrench to prevent flare nuts and brake tube from being damaged. To install, use flare nut torque wrench, tighten flare nut to the specified torque. Refer to [BR-11, "Hydraulic Circuit"](#).
- Do not apply excessive impact to ABS actuator and electric unit (control unit), such as dropping it.
- Do not remove and install actuator by holding harness.
- After work is completed, bleed the air from the brake hydraulic system. Refer to [BR-9, "Bleeding Brake System"](#).

REMOVAL

1. Disconnect the battery negative terminal.
2. Remove the cowl top. Refer to [EI-22, "Removal and Installation"](#).
3. Disconnect ABS actuator and electric unit (control unit) connector.
4. Loosen brake tube flare nuts, then remove brake tubes from ABS actuator and electric unit (control unit).
5. Remove brake booster hose from engine. Refer to [BR-23, "Removal and Installation"](#).
6. Remove ABS actuator and electric unit (control unit) bracket bolts.
7. Remove ABS actuator and electric unit (control unit).

ACTUATOR AND ELECTRIC UNIT (ASSEMBLY)

< SERVICE INFORMATION >

[VDC/TCS/ABS]

INSTALLATION

Installation is in the reverse order of removal.

- Bleed the brake system. Refer to [BR-9, "Bleeding Brake System"](#).
- Adjust steering angle sensor neutral position, if equipped. Refer to [BRC-85, "Adjustment of Steering Angle Sensor Neutral Position"](#).

CAUTION:

After installing harness connector in the ABS actuator and electric unit (control unit), make sure the connector is securely locked.

STEERING ANGLE SENSOR

< SERVICE INFORMATION >

[VDC/TCS/ABS]

STEERING ANGLE SENSOR

Removal and Installation

INFOID:000000005612185

NOTE:

The steering angle sensor is part of the spiral cable assembly and is not available separately.

REMOVAL

Remove the spiral cable. Refer to [SRS-37, "Removal and Installation"](#).

INSTALLATION

Installation is in the reverse order of removal.

CAUTION:

Perform the neutral position adjustment for the steering angle sensor. Refer to [BRC-85, "Adjustment of Steering Angle Sensor Neutral Position"](#).

A
B
C
D
E
G
H
I
J
K
L
M
N
O
P

BRC

G SENSOR

Removal and Installation

INFOID:000000005612186

EXPLODED VIEW

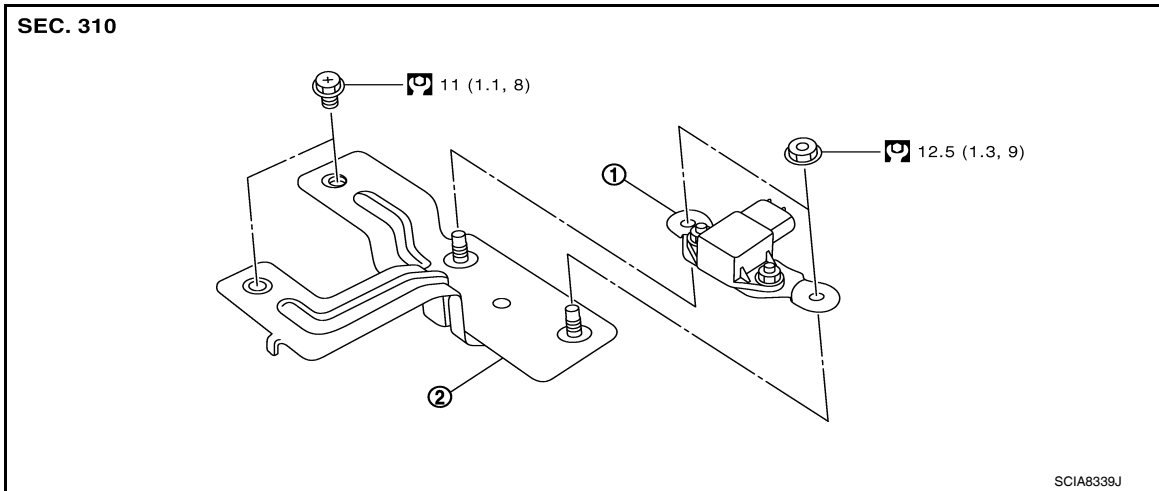

- 1. Yaw rate/side/decel G sensor
- 2. Bracket

REMOVAL

1. Disconnect battery negative terminal.
2. Remove driver seat. Refer to [SE-12, "Removal and Installation"](#).
3. Partially remove and reposition carpet from driver seat area. Refer to [EI-46, "Removal and Installation"](#).
4. Disconnect harness connector (A).
5. Remove attaching nuts (B) and remove yaw rate/side/decel G sensor (1).

CAUTION:

- Do not drop or strike the yaw rate/side/decel G sensor.
- Do not use power tools to remove or install yaw rate/side/decel G sensor.

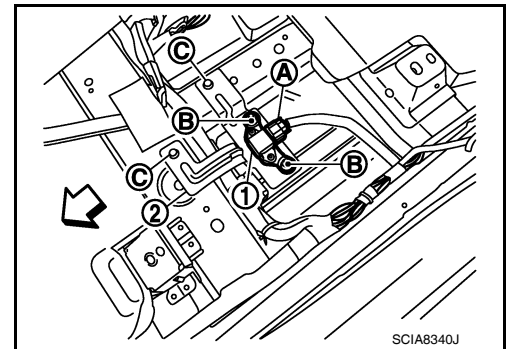

INSTALLATION

Installation is in the reverse order of removal.

CAUTION:

- Do not drop or strike the yaw rate/side/decel G sensor.