

A  
B  
C

# SECTION PS

## POWER STEERING SYSTEM

### CONTENTS

<b>SERVICE INFORMATION</b> .....	2	Removal and Installation .....	7	F
<b>PRECAUTIONS</b> .....	2	<b>STEERING COLUMN</b> .....	10	
Precaution for Supplemental Restraint System (SRS) "AIR BAG" and "SEAT BELT PRE-TENSIONER" .....	2	Removal and Installation .....	10	PS
Precaution Necessary for Steering Wheel Rotation After Battery Disconnect .....	2	<b>STEERING SHAFT</b> .....	13	
Precaution for Steering System .....	3	Removal and Installation .....	13	H
<b>PREPARATION</b> .....	4	<b>POWER STEERING GEAR</b> .....	15	
Special Service Tool .....	4	Removal and Installation .....	15	I
Commercial Service Tool .....	4	Disassembly and Assembly .....	15	
<b>NOISE, VIBRATION AND HARSHNESS (NVH) TROUBLESHOOTING</b> .....	5	<b>SERVICE DATA AND SPECIFICATIONS (SDS)</b> .....	20	J
NVH Troubleshooting Chart .....	5	Steering Wheel .....	20	
<b>STEERING WHEEL</b> .....	6	Steering Angle .....	20	K
On-Vehicle Inspection and Service .....	6	Steering Column .....	20	
		Steering Outer Socket and Inner Socket .....	20	L
		Steering Gear .....	21	M
				N
				O
				P

# PRECAUTIONS

< SERVICE INFORMATION >

## SERVICE INFORMATION

### PRECAUTIONS

#### Precaution for Supplemental Restraint System (SRS) "AIR BAG" and "SEAT BELT PRE-TENSIONER"

INFOID:000000006409484

The Supplemental Restraint System such as "AIR BAG" and "SEAT BELT PRE-TENSIONER", used along with a front seat belt, helps to reduce the risk or severity of injury to the driver and front passenger for certain types of collision. This system includes seat belt switch inputs and dual stage front air bag modules. The SRS system uses the seat belt switches to determine the front air bag deployment, and may only deploy one front air bag, depending on the severity of a collision and whether the front occupants are belted or unbelted. Information necessary to service the system safely is included in the SRS and SB section of this Service Manual.

#### **WARNING:**

- To avoid rendering the SRS inoperative, which could increase the risk of personal injury or death in the event of a collision which would result in air bag inflation, all maintenance must be performed by an authorized NISSAN/INFINITI dealer.
- Improper maintenance, including incorrect removal and installation of the SRS can lead to personal injury caused by unintentional activation of the system. For removal of Spiral Cable and Air Bag Module, see the SRS section.
- Do not use electrical test equipment on any circuit related to the SRS unless instructed to in this Service Manual. SRS wiring harnesses can be identified by yellow and/or orange harnesses or harness connectors.

#### PRECAUTIONS WHEN USING POWER TOOLS (AIR OR ELECTRIC) AND HAMMERS

#### **WARNING:**

- When working near the Airbag Diagnosis Sensor Unit or other Airbag System sensors with the Ignition ON or engine running, DO NOT use air or electric power tools or strike near the sensor(s) with a hammer. Heavy vibration could activate the sensor(s) and deploy the air bag(s), possibly causing serious injury.
- When using air or electric power tools or hammers, always switch the Ignition OFF, disconnect the battery, and wait at least 3 minutes before performing any service.

#### Precaution Necessary for Steering Wheel Rotation After Battery Disconnect

INFOID:000000005929628

#### **NOTE:**

- This procedure is applied only to models with Intelligent Key system and NATS (NISSAN ANTI-THEFT SYSTEM).
- Remove and install all control units after disconnecting both battery cables with the ignition switch in the "LOCK" position.
- Always use CONSULT-III to perform self-diagnosis as a part of each function inspection after finishing work. If DTC is detected, perform trouble diagnosis according to self-diagnostic results.

For models equipped with the Intelligent Key system and NATS, an electrically controlled steering lock mechanism is adopted on the key cylinder.

For this reason, if the battery is disconnected or if the battery is discharged, the steering wheel will lock and steering wheel rotation will become impossible.

If steering wheel rotation is required when battery power is interrupted, follow the procedure below before starting the repair operation.

#### OPERATION PROCEDURE

1. Connect both battery cables.

#### **NOTE:**

Supply power using jumper cables if battery is discharged.

2. Use the Intelligent Key or mechanical key to turn the ignition switch to the "ACC" position. At this time, the steering lock will be released.
3. Disconnect both battery cables. The steering lock will remain released and the steering wheel can be rotated.
4. Perform the necessary repair operation.

# PRECAUTIONS

## < SERVICE INFORMATION >

5. When the repair work is completed, return the ignition switch to the "LOCK" position before connecting the battery cables. (At this time, the steering lock mechanism will engage). A
6. Perform a self-diagnosis check of all control units using CONSULT-III. B

### Precaution for Steering System

INFOID:000000005929629

- In case of removing steering gear assembly, make the final tightening with grounded and unloaded vehicle condition, and then check wheel alignment. C
- Observe the following precautions when disassembling. D
  - Before disassembly, thoroughly clean the outside of the unit. E
  - Disassembly should be done in a clean work area. It is important to prevent the internal parts from becoming contaminated by dirt or other foreign matter. F
  - For easier and proper assembly, place disassembled parts in order on a parts rack. PS
  - Use nylon cloth or paper towels to clean the parts; common shop rags can leave lint that might interfere with their operation. H
  - Do not reuse non-reusable parts. I
  - Before assembling, apply the specified grease to the directed parts. J

PS

H

I

J

K

L

M

N

O

P

# PREPARATION

< SERVICE INFORMATION >

## PREPARATION

### Special Service Tool

INFOID:000000005929630

The actual shapes of Kent-Moore tools may differ from those of special tools illustrated here.

Tool number (Kent-Moore No.) Tool name	Description
ST3127S000 (J-25742-1) Preload gauge (J-25765-A) 1. GG91030000 Torque wrench 2. HT62940000 ( — ) Socket adapter (1/2") 3. HT62900000 ( — ) Socket adapter (3/8")	Inspecting rotating torque for steering column assembly and pinion assembly
KV40107300 ( — ) Boot Band crimping tool	Installing boot bands
KV48103400 ( — ) Preload adapter	Inspecting of rotating torque for pinion assembly
— (J-44372) Pull gauge	Measuring steering wheel turning force and ball joint swinging force.

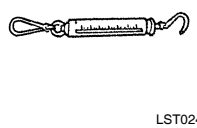
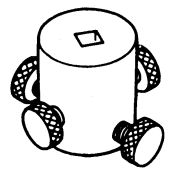
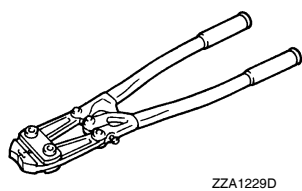
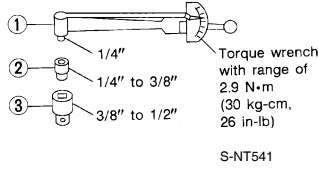

### Commercial Service Tool

INFOID:000000005929631

Tool number Tool name	Description
Power tool	Removing nuts and bolts

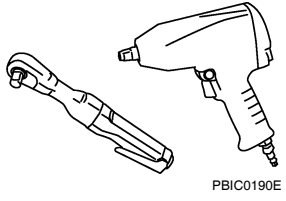



# STEERING WHEEL

< SERVICE INFORMATION >

## STEERING WHEEL

### On-Vehicle Inspection and Service

INFOID:000000006416714

#### CHECKING CONDITION OF INSTALLATION

- Check installation conditions of steering gear assembly, front suspension assembly, axle and steering column assembly.
- Check if movement exists when steering wheel is moved up and down, to the left and right and to the axial direction.

**Steering wheel axial end play : 0 mm (0 in)**

- Check steering gear assembly bolts and nuts for looseness. Refer to [PS-15, "Removal and Installation"](#).

#### CHECKING STEERING WHEEL PLAY

- Turn steering wheel so that front wheels come to the straight-ahead position. Start engine and lightly turn steering wheel to the left and right until front wheels start to move. Measure steering wheel movement on the outer circumference.

**Steering wheel play : 0 - 35 mm (0 - 1.38 in)**

- When the measurement value is outside the standard value, check backlash for each joint of steering column assembly and installation condition of steering gear assembly.

#### CHECKING NEUTRAL POSITION STEERING WHEEL

- Make sure that steering gear assembly, steering column assembly and steering wheel are installed in the correct position.
- Perform neutral position inspection after wheel alignment. Refer to [PS-2, "Precaution for Supplemental Restraint System \(SRS\) "AIR BAG" and "SEAT BELT PRE-TENSIONER" "](#)
- Set vehicle to the straight-ahead position and confirm steering wheel is in the neutral position.
- Loosen outer socket lock nut and turn inner socket to left and right equally to make fine adjustments if steering wheel is not in the neutral position.

#### CHECKING STEERING WHEEL TURNING FORCE

1. Park vehicle on a level and dry surface, set parking brake.
2. Start engine.
3. Check steering wheel turning force when steering wheel has been turned 360° from neutral position using Tool as shown.

**Tool number : — (J-44372)**

**Steering wheel turning force : Less than 36 N (3.7 kg-f, 8.2 lb-f)**

4. If steering wheel turning force is out of the specification, refer to [GI-9, "How to Follow Trouble Diagnosis"](#).

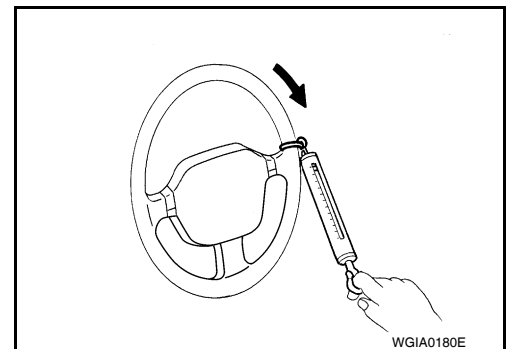

#### CHECKING FRONT WHEEL TURNING ANGLE

# STEERING WHEEL

## < SERVICE INFORMATION >

- Check front wheel turning angle after toe-in inspection. Place front wheels on turning radius gauges and rear wheels on stands. Check the maximum inner and outer wheel turning angles for LH and RH road wheels.

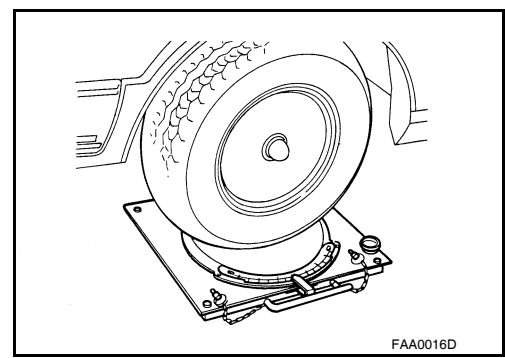

- With the engine at idle, turn steering wheel from full left stop to full right stop and measure the turning angles.

<b>Inner wheel (Angle: A)</b>	<b>Minimum</b>	<b>35° 00' (35.0°)</b>
	<b>Nominal</b>	<b>38° 00' (38.0°)</b>
	<b>Maximum</b>	<b>39° 00' (39.0°)</b>
<b>Outer wheel (Angle: B)</b>		<b>33° 00' (33.0°)</b>

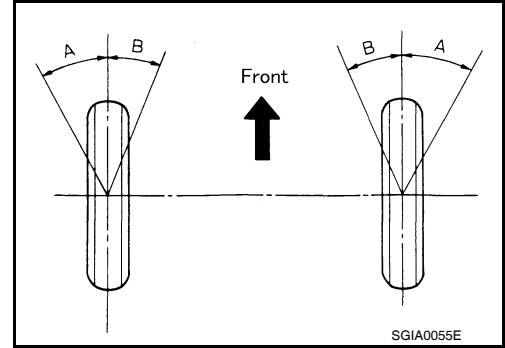

- Measure rack stroke if angles are outside the specified value.

**Rack stroke (L) : 65.0 mm (2.559 in)**

- Disassemble steering gear assembly to check the cause that rack stroke is outside of the standard.
- Steering angles are not adjustable. Check steering gear assembly, steering column assembly and front suspension components for wear or damage if any of the turning angles are different from the specified value. Replace any of them, if any non-standard condition exists.

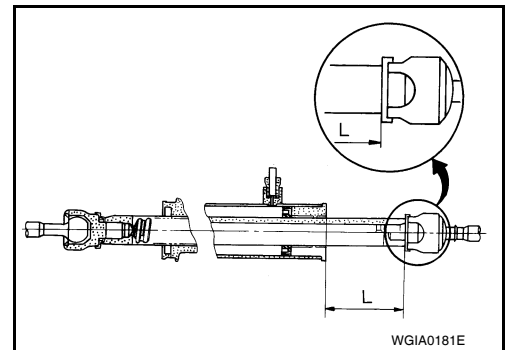

INFOID:000000006416715

## Removal and Installation

### COMPONENT

# STEERING WHEEL

< SERVICE INFORMATION >

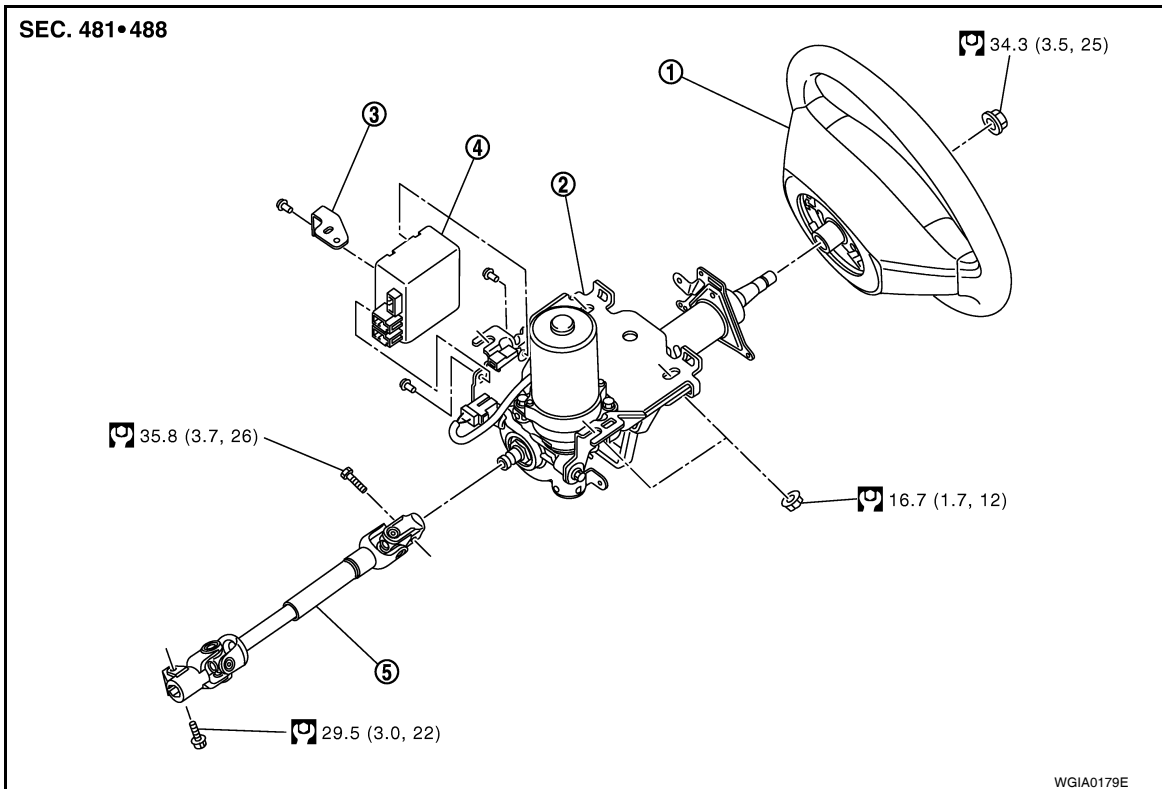

- |                     |  |            |
|---------------------|--|------------|
| 1. Steering wheel   | 2. Steering column assembly (with motor, reduction gear, sensor) | 3. Bracket |
| 4. EPS control unit | 5. Intermediate shaft  |            |

## CAUTION:

- After installing steering wheel, perform wheel alignment. Refer to [FSU-7, "Wheel Alignment Inspection"](#).

## REMOVAL

### NOTE:

When reconnecting spiral cable, secure cable with a tape so that case and rotating part keep aligned. This will omit neutral position alignment procedure during spiral cable installation.

1. Set vehicle to the straight-ahead position.
2. Remove driver air bag module. Refer to [SRS-34, "Removal and Installation"](#).
3. Remove steering wheel lock nut after steering is locked.
4. Remove steering wheel.

## INSTALLATION

Installation is in the reverse order of removal.



## STEERING WHEEL

### < SERVICE INFORMATION >

- Align spiral cable correctly when installing steering wheel. Make sure spiral cable alignment and centering marks (B) are matched and in the neutral position. The neutral position is detected by turning left 2.5 revolutions from the right end position, ending with the locating pin (A) at the top. Place steering wheel in straight ahead position, then install it with the locating pin hole (C) directly over spiral cable locating pin.
- After the work is completed, perform self-diagnosis to make sure no malfunction is detected. Refer to [SRS-19. "SRS Operation Check"](#).

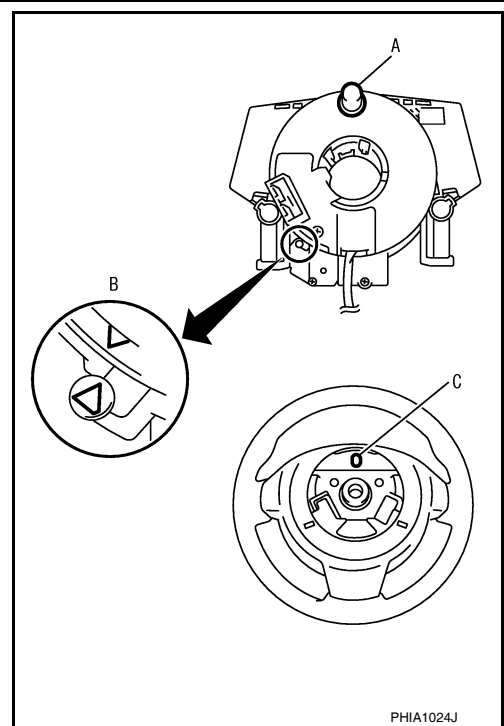

- Tighten steering wheel lock nut to specification.

# STEERING COLUMN

< SERVICE INFORMATION >

## STEERING COLUMN

### Removal and Installation

INFOID:000000006416716

#### COMPONENT

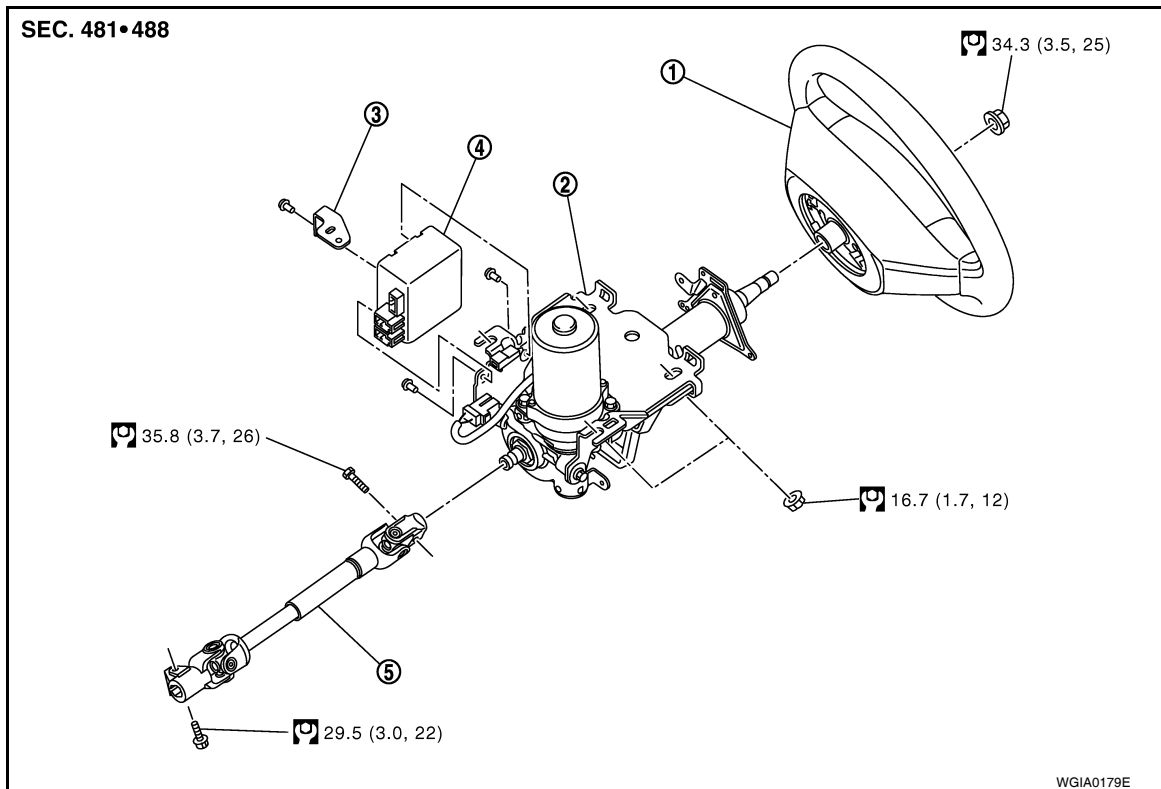

- |                     |  |            |
|---------------------|--|------------|
| 1. Steering wheel   | 2. Steering column assembly (with motor, reduction gear, sensor) | 3. Bracket |
| 4. EPS control unit | 5. Intermediate shaft  |            |

#### CAUTION:

- Do not allow axial impact to steering column assembly during removal and installation.
- Steering column must be kept at maximum tilt up position during removal and installation. Do not operate tilt mechanism while steering column is out of the vehicle.
- Put matching mark on intermediate shaft and steering column assembly before removing steering column.
- When steering wheel is turned repeatedly with the vehicle stopped, care must be taken because motor and EPS control unit may get too hot.
- Steering column assembly is heavy. Care must be taken when removing steering column assembly from vehicle.
- Do not put steering column assembly near the things that generate excessive magnetic force.
- Steering column assembly (with motor, reduction gear, sensor) cannot be disassembled.
- After installing steering column, perform wheel alignment. Refer to [FSU-7, "Wheel Alignment Inspection"](#).

#### REMOVAL

1. Set vehicle to the straight ahead-position.
2. Remove driver air bag module. Refer to [SRS-34, "Removal and Installation"](#).
3. Remove steering wheel. Refer to [PS-7, "Removal and Installation"](#).
4. Remove steering column cover (upper and lower). Refer to [IP-11, "Component Parts"](#).
5. Remove combination switch and spiral cable. Refer to [SRS-37, "Removal and Installation"](#).
6. Remove instrument lower finisher. Refer to [IP-11, "Component Parts"](#).

# STEERING COLUMN

## < SERVICE INFORMATION >

7. Disconnect each switch connector installed to steering column assembly, and then disconnect harness from steering column assembly.
8. Remove bolt of intermediate shaft (upper side), and then remove intermediate shaft from steering column assembly.
9. Remove steering column assembly nuts, and then remove steering column assembly from vehicle.
10. Remove screws of bracket and EPS control unit, and then remove bracket and EPS control unit from steering column assembly.

## INSPECTION AFTER REMOVAL

- Check each part of steering column assembly, EPS control unit and intermediate shaft for damage and replace as necessary.
- Measure the length (L) as shown, if vehicle has been involved in a minor collision. Replace steering column assembly (with motor, reduction gear, sensor) if outside the standard.

**Steering column length (L)** : Refer to [PS-20, "Steering Column"](#).

- Check tilt mechanism for damage or other malfunctions. Replace steering column assembly (with motor, reduction gear, sensor) as necessary.
- Measure steering column assembly rotating torque using Tool. Replace steering column assembly (with motor, reduction gear, sensor) if outside the standard.

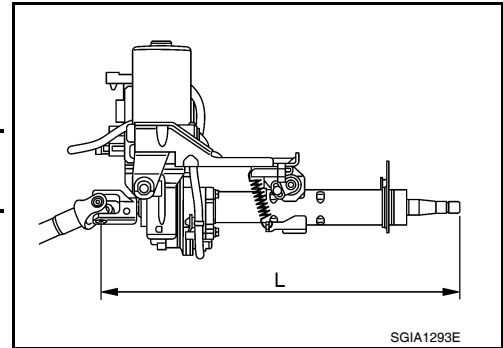

**Tool number** : ST3127S000 (J-25742-1)

**Rotating torque** : Refer to [PS-20, "Steering Column"](#).

## INSTALLATION

Installation is in the reverse order of removal.

- Installation is in the reverse order of removal.
- When tightening bolt (intermediate shaft lower side), tighten it by hand first, and make sure there is no feeling of sticking or galling before final tightening.

### CAUTION:

**Insert bolt in the proper direction. (Do not insert it from the other side.)**

- When connecting intermediate shaft upper side (1) and column shaft, make sure the bolt is securely seated in groove (A) of column shaft (A) before final tightening.

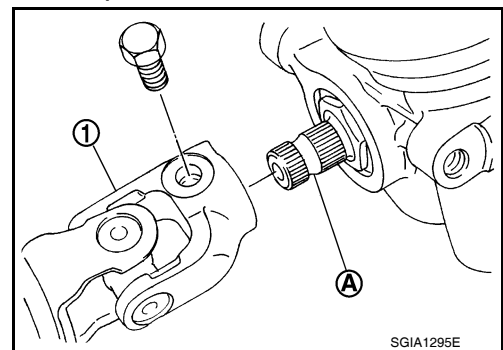

## INSPECTION AFTER INSTALLATION

- Rotate steering wheel to check for decentered condition, binding, noise or excessive steering effort.
- After installing steering column assembly, perform self-diagnosis with CONSULT-III to ensure correct operation. Refer to [STC-8, "CONSULT-III Function"](#).

## STEERING COLUMN

### < SERVICE INFORMATION >

- Check tilt mechanism operating range (L) as shown.

**Tilt operating  
range (L)**

**: Refer to [PS-20, "Steering Column"](#).**

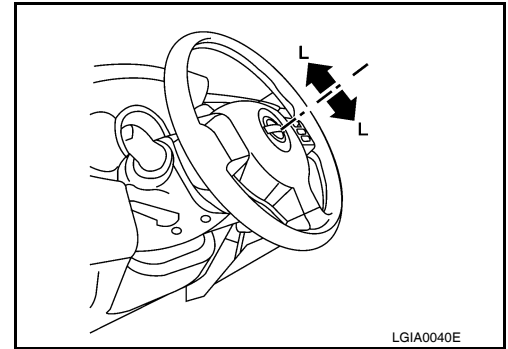

# STEERING SHAFT

< SERVICE INFORMATION >

## STEERING SHAFT

### Removal and Installation

INFOID:000000006416717

#### COMPONENT

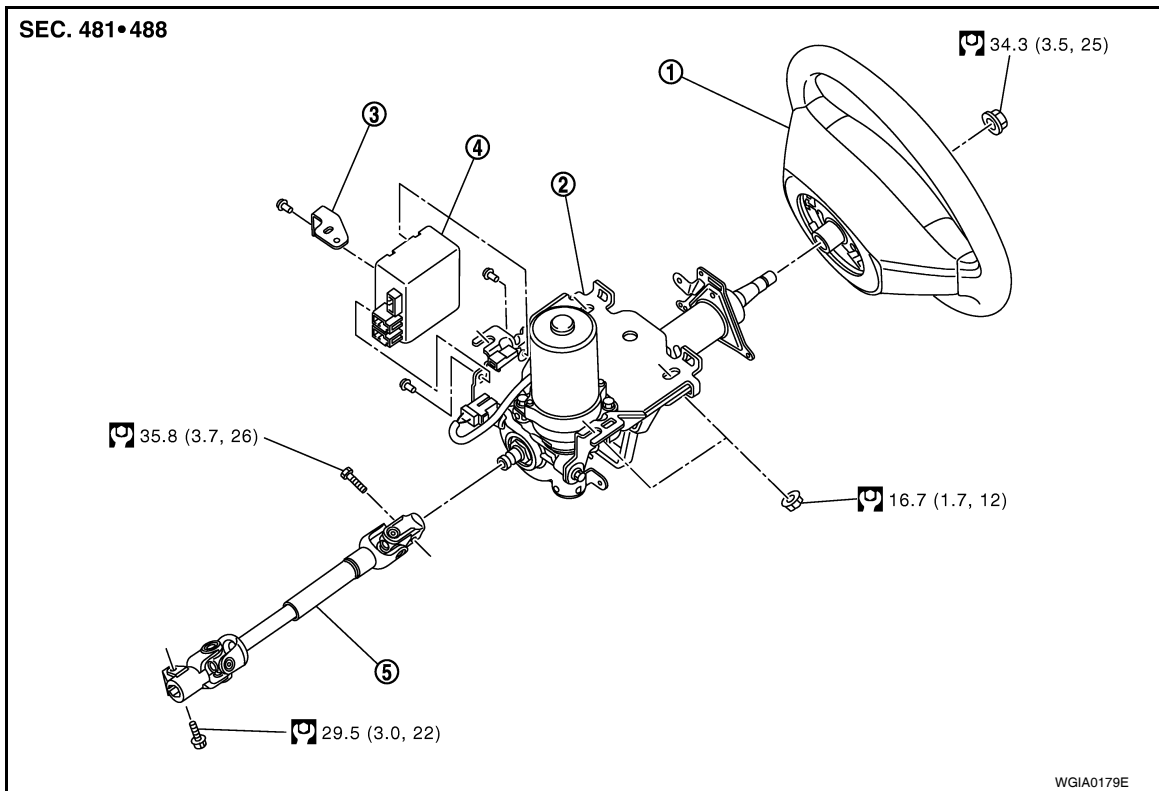

- |                     |  |            |
|---------------------|--|------------|
| 1. Steering wheel   | 2. Steering column assembly (with motor, reduction gear, sensor) | 3. Bracket |
| 4. EPS control unit | 5. Intermediate shaft  |            |

#### CAUTION:

- Put matching mark on intermediate shaft and steering column assembly before removing intermediate shaft.
- After installing intermediate shaft, perform wheel alignment. Refer to [FSU-7, "Wheel Alignment Inspection"](#).

#### REMOVAL

1. Set vehicle to the straight ahead-position.
2. Remove instrument lower finisher. Refer to [IP-11, "Component Parts"](#).
3. Remove bolt of intermediate shaft (upper side), and then remove intermediate shaft from steering column assembly.
4. Remove bolt of intermediate shaft (lower side), and then remove intermediate shaft from vehicle.

#### INSPECTION AFTER REMOVAL

- Check intermediate shaft for damage and replace as necessary.

#### INSTALLATION

Installation is in the reverse order of removal.

- Installation is in the reverse order of removal.
- When tightening bolt (intermediate shaft lower side), tighten it by hand first, and make sure there is no feeling of sticking or galling before final tightening.

#### CAUTION:

Insert bolt in the proper direction. (Do not insert it from the other side).

## STEERING SHAFT

### < SERVICE INFORMATION >

- When connecting intermediate shaft upper side (1) and column shaft, make sure the bolt is securely seated in groove (A) of column shaft (A) before final tightening.

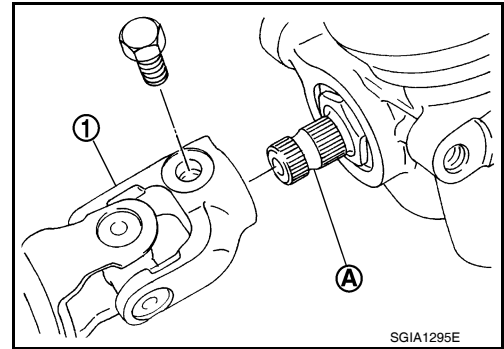

### INSPECTION AFTER INSTALLATION

- Rotate steering wheel to check for decentered condition, binding, noise or excessive steering effort.

# POWER STEERING GEAR

< SERVICE INFORMATION >

## POWER STEERING GEAR

### Removal and Installation

INFOID:000000005929636

#### COMPONENT

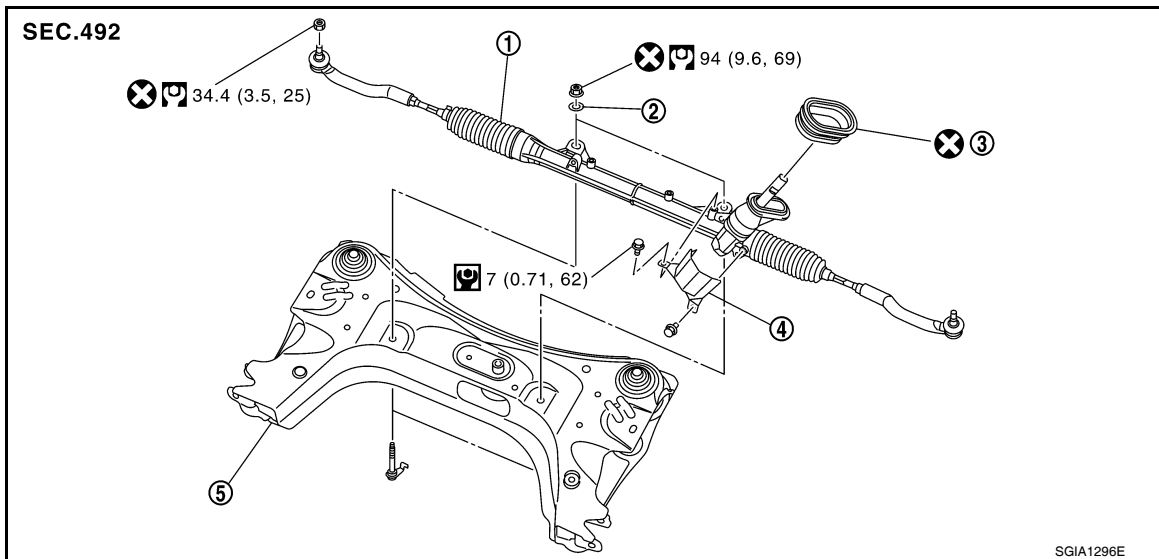

- |                           |                            |                    |
|---------------------------|----------------------------|--------------------|
| 1. Steering gear assembly | 2. Washer                  | 3. Lower dash seal |
| 4. Heat insulator         | 5. Front suspension member |                    |

Refer to [GI-7, "Description"](#) for the symbols.

#### CAUTION:

**Spiral cable may be cut if steering wheel turns while separating steering column assembly and steering gear assembly. Be sure to secure steering wheel using string to avoid turning.**

#### REMOVAL

1. Remove front suspension member. Refer to [FSU-11, "Removal and Installation"](#).
2. Remove mounting bolts and nuts of steering gear assembly.

#### INSTALLATION

Installation is in the reverse order of removal.

- Clean mounting surface on the body side of lower dash seal when installing steering gear assembly.
- Check wheel alignment under unladen conditions with tires on level ground. Refer to [FSU-7, "Wheel Alignment Inspection"](#).

#### INSPECTION AFTER INSTALLATION

Rotate steering wheel to check for decentered condition, binding, noise or excessive steering effort.

#### Disassembly and Assembly

INFOID:000000005929637

#### COMPONENT (R24K TYPE)

# POWER STEERING GEAR

< SERVICE INFORMATION >

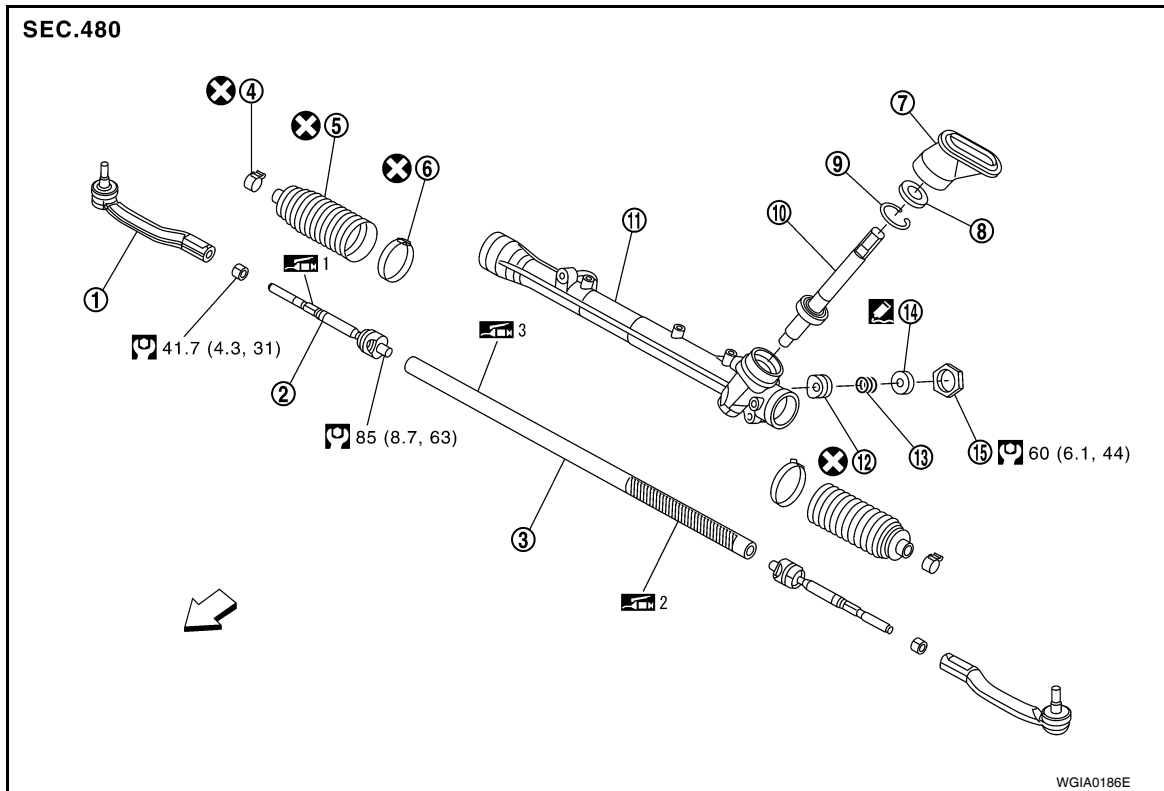

- |     |                             |     |                       |     |                             |
|-----|-----------------------------|-----|-----------------------|-----|-----------------------------|
| 1.  | Outer socket                | 2.  | Inner socket          | 3.  | Rack assembly               |
| 4.  | Boot clamp (small diameter) | 5.  | Boot                  | 6.  | Boot clamp (large diameter) |
| 7.  | Joint cover                 | 8.  | Pinion seal           | 9.  | Snap ring                   |
| 10. | Pinion assembly             | 11. | Gear housing assembly | 12. | Retainer                    |
| 13. | Spring                      | 14. | Adjusting screw       | 15. | Lock nut                    |

⇐ : Front

Refer to [GL-7](#) for the symbols unless shown below.

: Apply Genuine Thread Locking Sealant, Three Bound 1141 or equivalent.

1: Apply Genuine Lithium Soap, Idemitsu Autorex A or equivalent.

2: Apply Genuine Lithium Soap, Wanlouver MO No.2 (manufactured by Kyoudouyushi) or equivalent.

3: Apply Genuine Lithium Soap, Multemp AC-P (manufactured by Kyoudouyushi) or equivalent.

## CAUTION:

**Clean steering gear assembly with kerosene before disassembling.**

## DISASSEMBLY

- Loosen outer socket lock nut, and then remove outer socket from inner socket.
- Remove boot clamp, and then remove boot from inner socket.

## CAUTION:

**Do not damage inner socket and gear housing assembly when removing boot. Inner socket and gear housing assembly must be replaced if inner socket and gear housing assembly are damaged because it may allow foreign material to enter.**

- Remove inner socket from rack assembly while holding the flat portion of the rack next to the inner socket using a suitable tool.



# POWER STEERING GEAR

## < SERVICE INFORMATION >

4. Measure adjusting screw height "H", and loosen lock nut (2).
5. Remove adjusting screw (1), retainer (3) and spring (4) from gear housing assembly (5).

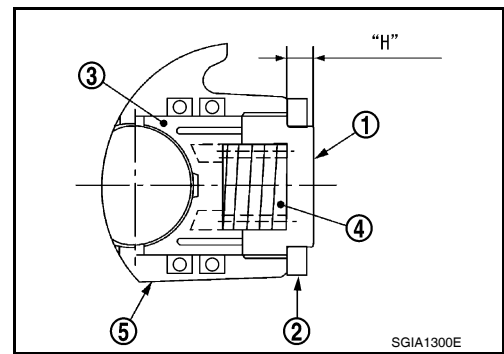

## INSPECTION AFTER DISASSEMBLY

### Joint Cover

Check joint cover protrusion for damage. Replace if there are.

### Rack and Pinion Assembly

- Check pinion assembly for damage or wear. Replace as necessary.
- Rotate pinion assembly and check for torque variation or rattle. Replace steering gear as necessary.

### Gear Housing Assembly

Check gear housing assembly for damage or scratches. Replace steering gear as necessary.

### Outer Socket and Inner Socket

1. Check ball joint swinging torque.
  - Hook Tool at the point shown and pull the spring balance. Make sure that the spring balance reads the specified value when ball stud and inner socket start to move. Replace outer socket and inner socket if they are outside the standard.

**Tool number** : — (J-44372)

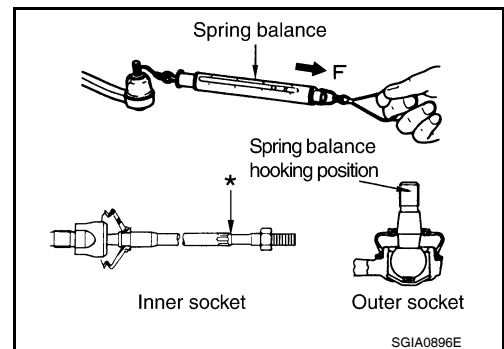

Items	Outer socket	Inner socket
Measuring point of spring balance	Ball stud upper side	Measuring point at * mark shown in the figure
Swinging torque	Refer to <a href="#">PS-20, "Steering Outer Socket and Inner Socket"</a> .	Refer to <a href="#">PS-20, "Steering Outer Socket and Inner Socket"</a> .
Spring balance measurement		

2. Ball joint axial end play
  - Apply an axial load of 490 N (50 kg-f, 111 lb-f) to ball stud. Measure amount of stud movement using a dial gauge, and then make sure that the value is within the specified range. Replace outer socket and inner socket if the measured value is outside the standard.

Outer socket axial end play	Refer to <a href="#">PS-20, "Steering Outer Socket and Inner Socket"</a> .
Inner socket axial end play	

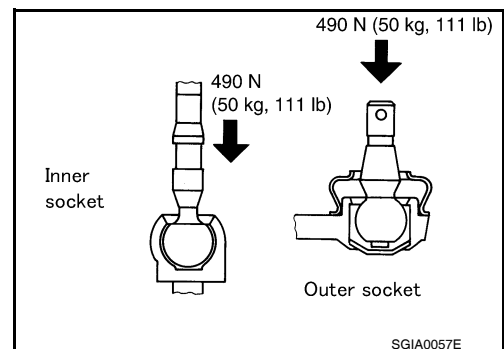

## ASSEMBLY

1. Apply recommended grease to teeth part and bush part of rack assembly, if necessary.
2. Apply recommended grease to back of rack assembly, if necessary.

# POWER STEERING GEAR

## < SERVICE INFORMATION >

3. Install inner socket to rack assembly. Torque to specified value while holding the flat portion of the rack next to the inner socket using a suitable tool.
4. Apply recommended grease to inner socket.
5. Decide on the neutral position for the rack assembly.

**Rack stroke "L" : Refer to [PS-21, "Steering Gear"](#).**

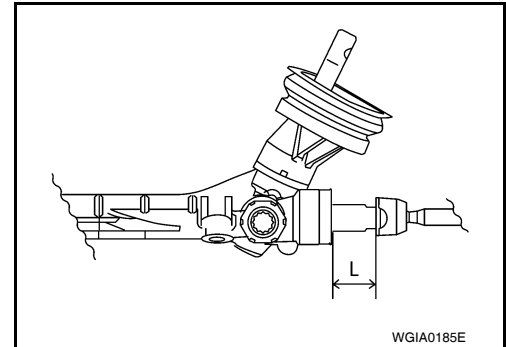

6. Apply recommended grease to around retainer (3), then install retainer (3), spring (4) and adjusting screw (1) to gear housing assembly (5).
7. Apply recommended thread locking sealant to the thread (2 turns thread), and then screw in the adjusting screw (1) until it reaches height "H" from gear housing assembly (5) measured before disassembling.
8. Tighten lock nut to (2) the specified torque securing it to prevent adjusting screw (1) from freewheeling condition.
9. Move rack assembly 10 strokes throughout the full stroke so that the parts can fit with each other.
10. Using Tools A and B, measure rotating torque of pinion assembly. If the measurement is outside of the specified range, readjust pinion rotating torque. If the measurement is outside of the specified range for readjust, replace steering gear assembly.

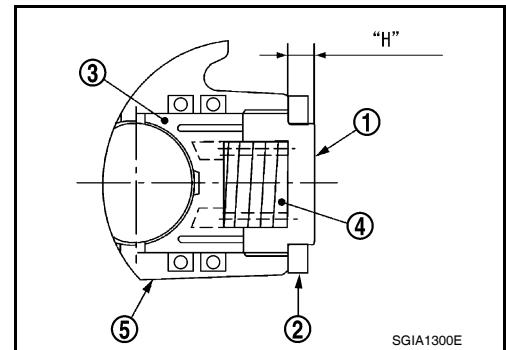

**Tool numbers A: ST3127S000 (J-25742-1)**  
**B: KV48103400 ( — )**

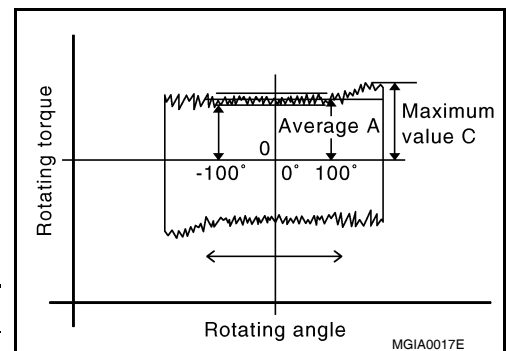

### Pinion rotating torque standard

**Around neutral position (within  $\pm 100^\circ$ ) Average A**

**Refer to [PS-21, "Steering Gear"](#).**

**Maximum variation C**

11. Set dial gauge to the back of rack assembly on the pinion assembly side around the center of stroke. Measure displacement of rack under torsional torque of  $\pm 7.8$  N·m (0.80 kg·m, 69 in·lb), and then check if it is within the standard value. If the measurement is outside the standard value, adjust it again. After the readjustment, if measurement is still outside the standard value, replace steering gear assembly.

**Standard value : Less than 0.1 mm (0.004 in)**

12. Install boot to gear housing assembly and inner socket.

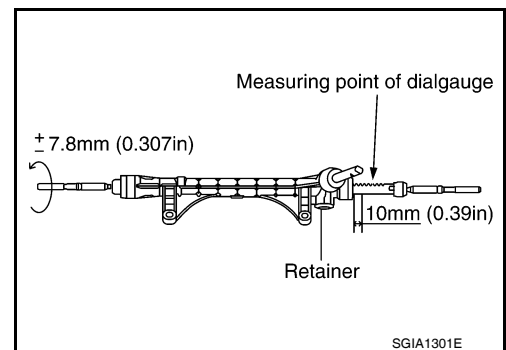

# POWER STEERING GEAR

## < SERVICE INFORMATION >

13. Install boot clamp (1) to boot using Tool.

**NOTE:**

Install large diameter side boot clamp (1) securely to boot groove, and crimp it so as to have clearance of 3 mm (0.12 in) or less as shown.

**Tool number** : KV40107300 ( — )

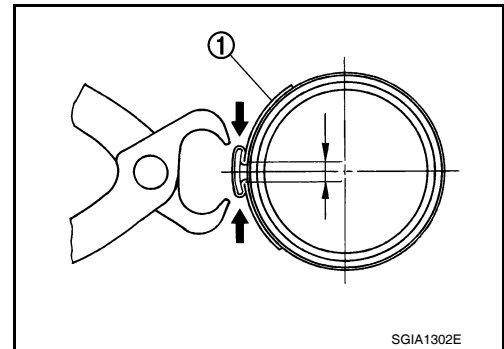

14. Install joint cover (1) to gear housing assembly (2).

**CAUTION:**

Install joint cover so that the protrusion for locating is securely set to gear housing groove.

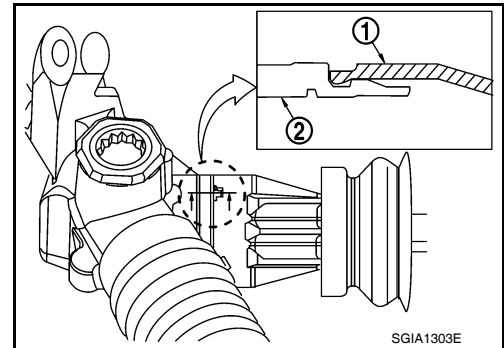

15. Adjust inner socket to standard length "L", and then tighten lock nut to the specified torque. Check length of inner socket "L" again after tightening lock nut. Make sure that the length is the standard.

**Inner socket length "L"** : Refer to [PS-20, "Steering Outer Socket and Inner Socket"](#)

**CAUTION:**

Adjust toe-in. Refer to [FSU-7, "Wheel Alignment Inspection"](#). Length achieved after toe-in adjustment is not necessarily the above value.

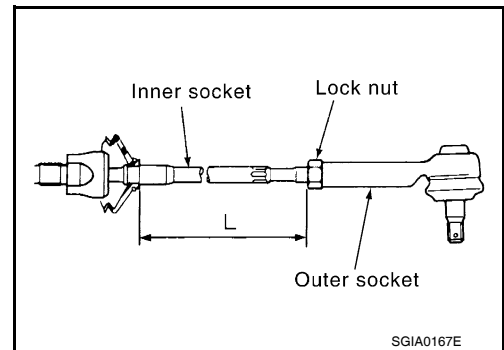

A  
B  
C  
D  
E  
F  
PS  
H  
I  
J  
K  
L  
M  
N  
O  
P

# SERVICE DATA AND SPECIFICATIONS (SDS)

< SERVICE INFORMATION >

## SERVICE DATA AND SPECIFICATIONS (SDS)

### Steering Wheel

INFOID:000000005929638

Steering wheel axial end play	0 mm (0 in)
Steering wheel play	0 - 35 mm (0 - 1.38 in)
Steering wheel turning force	Less than 36 N (3.7 kg-f, 8.2 lb-f)

### Steering Angle

INFOID:000000005929639

Inner wheel Degree minute (Decimal degree)	Minimum	35° 00' (35.0°)
	Nominal	38° 00' (38.0°)
	Maximum	39° 00' (39.0°)
Outer wheel Degree minute (Decimal degree)		33° 00' (33.0°)

### Steering Column

INFOID:000000005929640

Steering column length "L"	Minimum	462.1 mm (18.19 in)
	Nominal	464.1 mm (18.27 in)
	Maximum	466.1 mm (18.35 in)

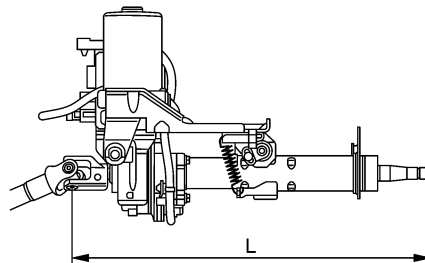

SGIA1293E

Steering column assembly rotating torque	0 - 2.1 N·m (0 - 0.21 kg-m, 0 - 18 in-lb)
Tilt operating range	20 mm (0.79 in)

### Steering Outer Socket and Inner Socket

INFOID:000000005929641

Steering gear type		R24K
Outer socket ball stud	Swinging torque	0.3 - 2.9 N·m (0.03 - 0.29 kg-m, 3.0 - 25 in-lb)
	Measurement on spring balance Measuring point: ball stud upper side	6.0 - 58 N (0.61 - 5.91 kg-f, 1.35 - 13.03 lb-f)
	Axial end play	0.5 mm (0.020 in) or less
Inner socket ball joint	Swinging torque	0.5 - 5.0 N·m (0.06 - 0.51 kg-m, 5 - 44 in-lb)
	• Measurement on spring balance • Measuring point at *mark shown	4.3 - 43.5 N (0.44 - 4.44 kg-f, 0.97 - 9.79 lb-f)
	Axial end play	0.2 mm (0.008 in) or less

# SERVICE DATA AND SPECIFICATIONS (SDS)

## < SERVICE INFORMATION >

Steering gear type	R24K
Inner socket length "L"	57.8 mm (2.276 in)

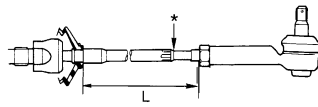

SGIA0950E

## Steering Gear

INFOID:000000005929642

Steering gear model	R24K
Rack neutral position, dimension "L" (rack stroke)	65.0 mm (2.559 in)

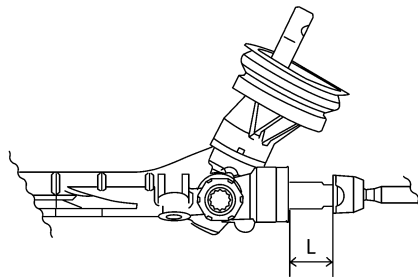

WGIA0185E

Pinion rotating torque standard	Around neutral position (within $\pm 100^\circ$ ) Average A	0.3 - 1.5 N·m (0.03 - 0.15 kg-m, 3 - 13 in-lb)
	Maximum variation C	1.86 N·m (0.19 kg-m, 16 in-lb)

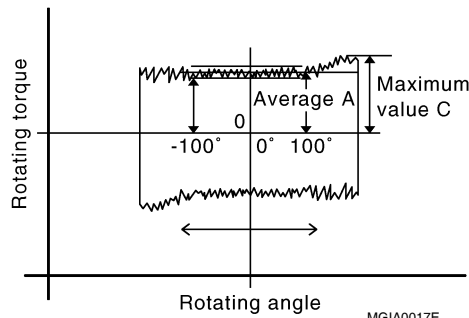

MGIA0017E