

SECTION **SRS**

SUPPLEMENTAL RESTRAINT SYSTEM (SRS)

A
B
C
D
E
F
G
SRS
I
J
K
L
M
N
O
P

CONTENTS

<p>PRECAUTION 2</p> <p>PRECAUTIONS 2</p> <p style="padding-left: 20px;">Precaution for Supplemental Restraint System (SRS) "AIR BAG" and "SEAT BELT PRE-TENSIONER"2</p> <p style="padding-left: 20px;">Precaution for SRS "AIR BAG" and "SEAT BELT PRE-TENSIONER" Service2</p> <p style="padding-left: 20px;">Precaution Necessary for Steering Wheel Rotation After Battery Disconnect2</p> <p style="padding-left: 20px;">Occupant Classification System Precaution3</p> <p>SYMPTOM DIAGNOSIS 4</p> <p>SUPPLEMENTAL RESTRAINT SYSTEM (SRS) 4</p> <p style="padding-left: 20px;">SRS Configuration4</p> <p style="padding-left: 20px;">Driver Air Bag Module5</p> <p style="padding-left: 20px;">Front Passenger Air Bag Module5</p> <p style="padding-left: 20px;">Front Side Air Bag5</p> <p style="padding-left: 20px;">Side Curtain Air Bag5</p> <p style="padding-left: 20px;">Front Seat Belt Pre-tensioner with Load Limiter6</p> <p style="padding-left: 20px;">Occupant Classification System (OCS)6</p> <p style="padding-left: 20px;">SRS Component Connectors7</p> <p>TROUBLE DIAGNOSIS 8</p> <p style="padding-left: 20px;">Trouble Diagnosis Introduction8</p> <p style="padding-left: 20px;">SRS Component Parts Location10</p> <p style="padding-left: 20px;">Schematic11</p> <p style="padding-left: 20px;">Wiring Diagram - SRS-12</p> <p style="padding-left: 20px;">CONSULT Function (AIR BAG)17</p> <p style="padding-left: 20px;">Self-Diagnosis Function (Without CONSULT)18</p> <p style="padding-left: 20px;">SRS Operation Check19</p> <p style="padding-left: 20px;">Trouble Diagnosis with CONSULT20</p> <p style="padding-left: 20px;">Trouble Diagnosis without CONSULT28</p> <p style="padding-left: 20px;">Trouble Diagnosis: "AIR BAG" Warning Lamp Does Not Turn Off32</p>	<p style="padding-left: 20px;">Trouble Diagnosis: "AIR BAG" Warning Lamp Does Not Turn On32</p> <p>ON-VEHICLE REPAIR34</p> <p>DRIVER AIR BAG MODULE34</p> <p style="padding-left: 20px;">Removal and Installation34</p> <p>SPIRAL CABLE37</p> <p style="padding-left: 20px;">Removal and Installation37</p> <p>FRONT PASSENGER AIR BAG MODULE39</p> <p style="padding-left: 20px;">Removal and Installation39</p> <p>SIDE CURTAIN AIR BAG MODULE40</p> <p style="padding-left: 20px;">Component40</p> <p style="padding-left: 20px;">Removal and Installation40</p> <p>SIDE AIR BAG MODULE42</p> <p style="padding-left: 20px;">Removal and Installation42</p> <p>CRASH ZONE SENSOR43</p> <p style="padding-left: 20px;">Removal and Installation43</p> <p>SIDE AIR BAG (SATELLITE) SENSOR44</p> <p style="padding-left: 20px;">Removal and Installation44</p> <p>FRONT SEAT BELT PRE-TENSIONER45</p> <p style="padding-left: 20px;">Removal and Installation45</p> <p>DIAGNOSIS SENSOR UNIT46</p> <p style="padding-left: 20px;">Removal and Installation46</p> <p>OCCUPANT CLASSIFICATION SYSTEM CONTROL UNIT48</p> <p style="padding-left: 20px;">Removal and Installation48</p> <p>COLLISION DIAGNOSIS49</p> <p style="padding-left: 20px;">For Frontal Collision49</p> <p style="padding-left: 20px;">For Side and Rollover Collision51</p>
--	--

PRECAUTIONS

< PRECAUTION >

PRECAUTION

PRECAUTIONS

Precaution for Supplemental Restraint System (SRS) "AIR BAG" and "SEAT BELT PRE-TENSIONER"

INFOID:000000007330533

The Supplemental Restraint System such as "AIR BAG" and "SEAT BELT PRE-TENSIONER", used along with a front seat belt, helps to reduce the risk or severity of injury to the driver and front passenger for certain types of collision. This system includes seat belt switch inputs and dual stage front air bag modules. The SRS system uses the seat belt switches to determine the front air bag deployment, and may only deploy one front air bag, depending on the severity of a collision and whether the front occupants are belted or unbelted. Information necessary to service the system safely is included in the SRS and SB section of this Service Manual.

WARNING:

- To avoid rendering the SRS inoperative, which could increase the risk of personal injury or death in the event of a collision which would result in air bag inflation, all maintenance must be performed by an authorized NISSAN/INFINITI dealer.
- Improper maintenance, including incorrect removal and installation of the SRS, can lead to personal injury caused by unintentional activation of the system. For removal of Spiral Cable and Air Bag Module, see the SRS section.
- Do not use electrical test equipment on any circuit related to the SRS unless instructed to in this Service Manual. SRS wiring harnesses can be identified by yellow and/or orange harnesses or harness connectors.

PRECAUTIONS WHEN USING POWER TOOLS (AIR OR ELECTRIC) AND HAMMERS

WARNING:

- When working near the Airbag Diagnosis Sensor Unit or other Airbag System sensors with the Ignition ON or engine running, DO NOT use air or electric power tools or strike near the sensor(s) with a hammer. Heavy vibration could activate the sensor(s) and deploy the air bag(s), possibly causing serious injury.
- When using air or electric power tools or hammers, always switch the Ignition OFF, disconnect the battery, and wait at least 3 minutes before performing any service.

Precaution for SRS "AIR BAG" and "SEAT BELT PRE-TENSIONER" Service

INFOID:000000007330534

- Do not use electrical test equipment to check SRS circuits unless instructed to in this Service Manual.
- Before servicing the SRS, turn ignition switch OFF, disconnect both battery cables and wait at least 3 minutes.
For approximately 3 minutes after the cables are removed, it is still possible for the air bag and seat belt pretensioner to deploy. Therefore, do not work on any SRS connectors or wires until at least 3 minutes have passed.
- The air bag diagnosis sensor unit must always be installed with the arrow mark "←" pointing toward the front of the vehicle for proper operation. Also check air bag diagnosis sensor unit for cracks, deformities or rust before installation and replace as required.
- The spiral cable must be aligned with the neutral position since its rotations are limited. Do not attempt to turn steering wheel or column after removal of steering gear.
- Handle air bag module carefully. Always place driver and front passenger air bag modules with the pad side facing upward and seat mounted front side air bag module standing with the stud bolt side facing down.
- Conduct self-diagnosis to check entire SRS for proper function after replacing any components.
- After air bag inflates, the front instrument panel assembly should be replaced if damaged.
- Do not reuse center pillar upper garnish if removed.

Precaution Necessary for Steering Wheel Rotation After Battery Disconnect

INFOID:000000007330535

NOTE:

- This Procedure is applied only to models with Intelligent Key system and NATS (NISSAN ANTI-THEFT SYSTEM).
- Remove and install all control units after disconnecting both battery cables with the ignition knob in the "LOCK" position.

PRECAUTIONS

< PRECAUTION >

- Always use CONSULT to perform self-diagnosis as a part of each function inspection after finishing work. If DTC is detected, perform trouble diagnosis according to self-diagnostic results.
- For models equipped with the Intelligent Key system and NATS, an electrically controlled steering lock mechanism is adopted on the key cylinder.
- For this reason, if the battery is disconnected or if the battery is discharged, the steering wheel will lock and steering wheel rotation will become impossible.
- If steering wheel rotation is required when battery power is interrupted, follow the procedure below before starting the repair operation.

OPERATION PROCEDURE

1. Connect both battery cables.
NOTE:
Supply power using jumper cables if battery is discharged.
2. Use the Intelligent Key or mechanical key to turn the ignition switch to the "ACC" position. At this time, the steering lock will be released.
3. Disconnect both battery cables. The steering lock will remain released and the steering wheel can be rotated.
4. Perform the necessary repair operation.
5. When the repair work is completed, return the ignition switch to the "LOCK" position before connecting the battery cables. (At this time, the steering lock mechanism will engage.)
6. Perform a self-diagnosis check of all control units using CONSULT.

Occupant Classification System Precaution

INFOID:000000007330536

Replace control unit and passenger front seat cushion as an assembly.

A
B
C
D
E
F
G
I
J
K
L
M
N
O
P

SRS

SUPPLEMENTAL RESTRAINT SYSTEM (SRS)

< SYMPTOM DIAGNOSIS >

SYMPTOM DIAGNOSIS

SUPPLEMENTAL RESTRAINT SYSTEM (SRS)

SRS Configuration

INFOID:000000007330537

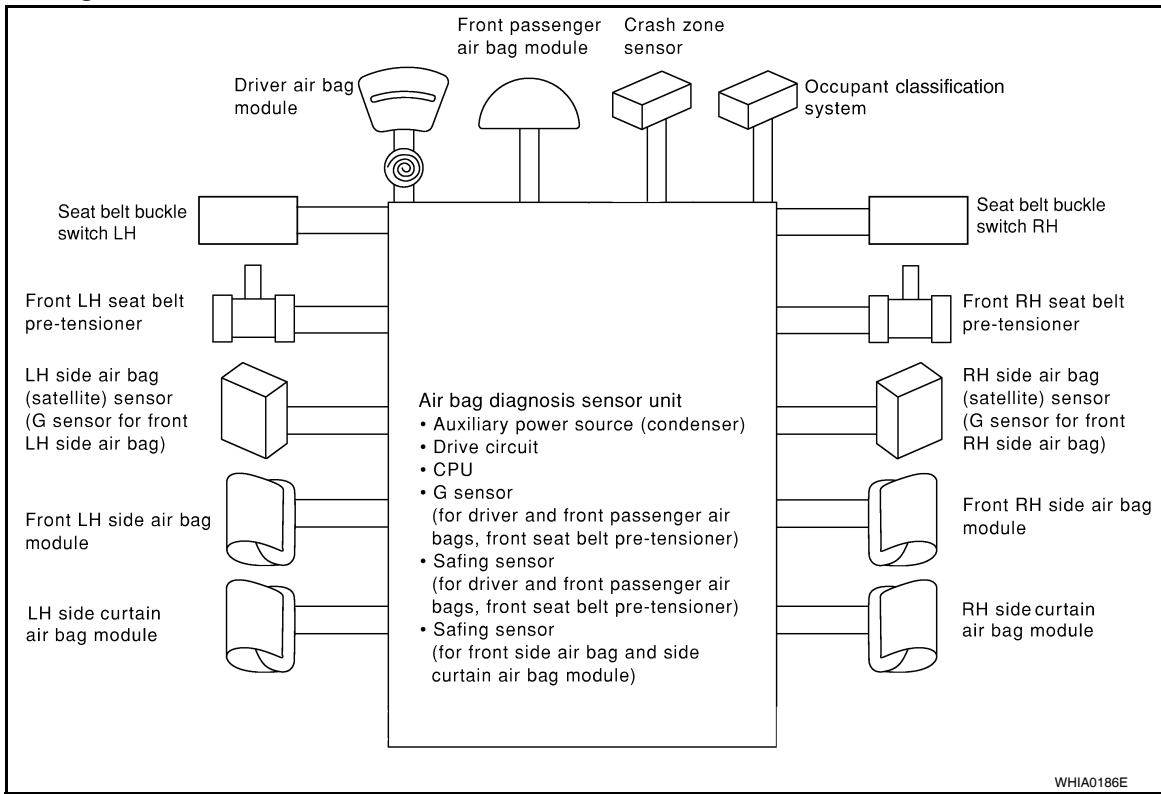

The air bag deploys if the air bag diagnosis sensor unit is activated while the ignition switch is in the ON or START position.

The collision modes for which supplemental restraint systems are activated are different among the SRS systems. For example, the driver air bag module, front passenger air bag module and front seat belt pre-tensioners are activated in a frontal collision but not in a side collision.

SRS configurations for some collision modes are as follows:

SRS configuration	Frontal collision	Left side collision	Right side collision
Driver air bag module	×	—	—
Front passenger air bag module	×	—	—
Front LH seat belt pre-tensioner	×	—	—
Front RH seat belt pre-tensioner	×	—	—
Front LH side air bag module	—	×	—
Front RH side air bag module	—	—	×
LH side curtain air bag module	—	×	—
RH side curtain air bag module	—	—	×

SUPPLEMENTAL RESTRAINT SYSTEM (SRS)

< SYMPTOM DIAGNOSIS >

Driver Air Bag Module

INFOID:000000007330538

The driver air bag module is dual stage and located in the steering wheel assembly. It operates with the SRS system in a frontal collision exceeding a specified level.

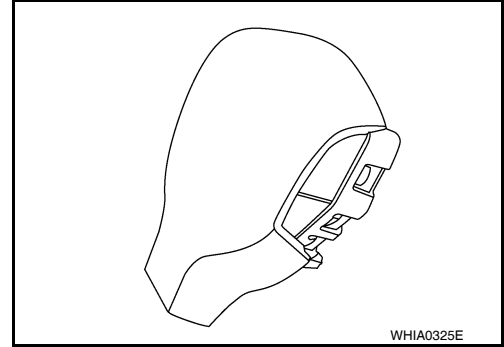

Front Passenger Air Bag Module

INFOID:000000007330539

The front passenger air bag module is located behind the instrument panel assembly (mounted to the steering member). It operates with the SRS system in a frontal collision exceeding a specified level. Refer to [SRS-6. "Occupant Classification System \(OCS\)"](#) for more information.

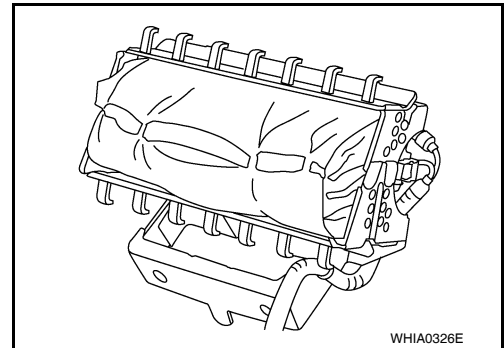

Front Side Air Bag

INFOID:000000007330540

Front side air bag modules are built into the front seatback assemblies. Vehicles with side air bags are equipped with labels as shown.

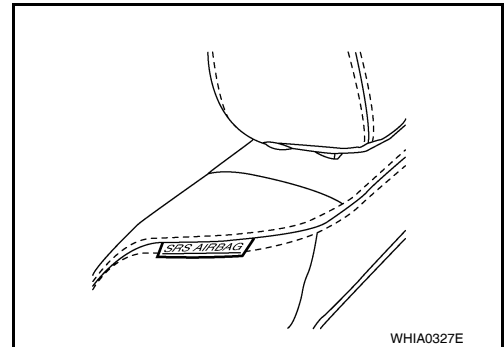

Side Curtain Air Bag

INFOID:000000007330541

Side curtain air bag modules are located above the vehicle headlining and run from the front to the rear of the vehicle. Vehicles with side curtain air bags are equipped with labels as shown.



A
B
C
D
E
F
G
SRS
I
J
K
L
M
N
O
P

SUPPLEMENTAL RESTRAINT SYSTEM (SRS)

< SYMPTOM DIAGNOSIS >

Front Seat Belt Pre-tensioner with Load Limiter

INFOID:000000007330542

The seat belt pre-tensioner system with load limiter is installed for both the driver's seat and the front passenger's seat. It operates simultaneously with the SRS air bag system in the event of a frontal collision with an impact exceeding a specified level.

When the frontal collision with an impact exceeding a specified level occurs, seat belt slack resulting from clothing or other factors is immediately taken up by the pre-tensioner. Vehicle passengers are securely restrained.

When passengers in a vehicle are thrown forward in a collision and the restraining force of the seat belt exceeds a specified level, the load limiter permits the specified extension of the seat belt by the twisting of the ELR shaft, and a relaxation of the chest-area seat belt web tension while maintaining force.

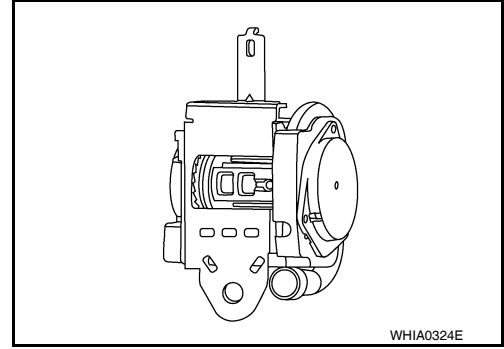

Occupant Classification System (OCS)

INFOID:000000007330543

The occupant classification system (OCS) identifies different size occupants, out of position occupants, and detects if child seat is present in the front passenger seat. The OCS receives inputs from the occupant classification system sensor (located under the passenger seat cushion assembly) and belt tension sensor (part of the passenger front seat belt assembly and located at the belt anchor location). Depending on classification of the passenger, the OCS sends a signal to the air bag diagnosis sensor unit. The air bag diagnosis sensor unit uses this signal and the seat belt buckle switch RH signal to determine deployment or non deployment of the front passenger air bag module in the event of a collision. Depending on the signals received, the air bag diagnosis sensor unit can disable the front passenger air bag module completely.

NOTE:

In case of customer concern, CONSULT can be used to confirm the passenger air bag status (readiness).

Passenger Air Bag Status Conditions

Front Passenger Seat (Condition)	PASS AIR BAG OFF Indicator (Status)	Passenger Air Bag Status (Readiness)	CONSULT Display
Seat occupied	OFF	Active (enabled)	ON
Seat occupied ^{NOTE}	ON	Deactivated (disabled)	OFF
Seat empty	OFF	Deactivated (disabled)	OFF

NOTE:

Passenger does not meet Occupant Classification System specifications for passenger air bag activation.

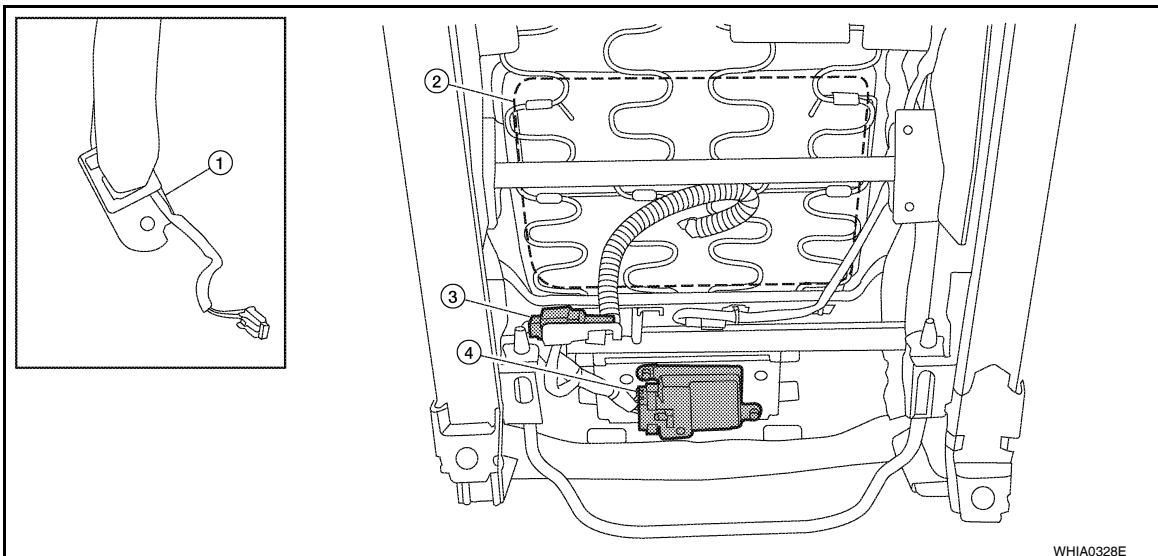

- 1. Belt tension sensor
- 2. Occupant classification system bladder
- 3. Occupant classification system sensor
- 4. Occupant classification system control unit

SUPPLEMENTAL RESTRAINT SYSTEM (SRS)

< SYMPTOM DIAGNOSIS >

SRS Component Connectors

INFOID:000000007687355

DIRECT CONNECT

The following SRS components use direct-connect style harness connectors.

- Driver front air bag module
- Passenger front air bag module
- LH side curtain air bag module
- RH side curtain air bag module
- Front LH seat belt pre-tensioner
- Front RH seat belt pre-tensioner

Always pull up to release locking tab prior to removing connector from SRS component.

Always push down to lock locking tab after installing connector to SRS component. When locked, the locking tab is level with the connector housing.

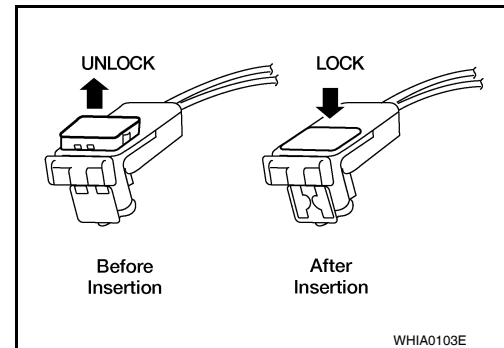

SLIDE DOUBLE LOCKING

- A new style slide double locking type connector is used on certain systems and components, especially those related to airbag control systems.
- The slide double locking type connectors help prevent incomplete locking and accidental looseness or disconnection.
- The slide double locking type connectors are disconnected by pushing or pulling the slider. Refer to the figure below.

CAUTION:

- Do not pull the harness or wires when disconnecting the connector.

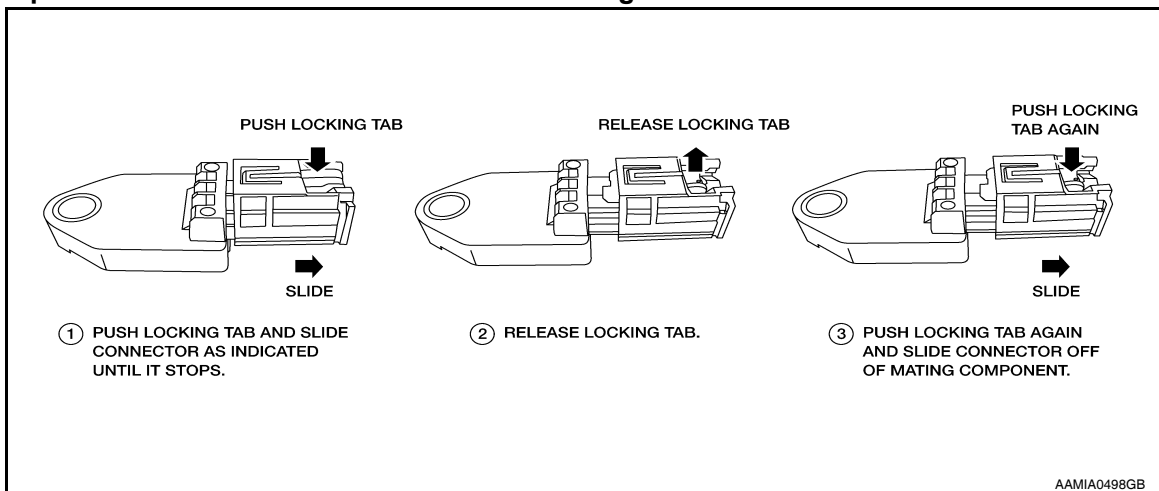

TROUBLE DIAGNOSIS

< SYMPTOM DIAGNOSIS >

TROUBLE DIAGNOSIS

Trouble Diagnosis Introduction

INFOID:000000007330545

CAUTION:

- Do not use electrical test equipment on any circuit related to the SRS unless instructed to do so in this Service Manual.
- Do not attempt to repair, splice or modify SRS wiring harnesses. If a harness is damaged, replace it with a new one.
- Keep ground connections clean.

DIAGNOSIS FUNCTION

The SRS self-diagnosis results can be read by using "AIR BAG" warning lamp and/or CONSULT.

The User mode is exclusively prepared for the customer (driver). This mode warns the driver of a system malfunction through the operation of the "AIR BAG" warning lamp.

The Diagnosis mode allows the technician to locate and inspect the malfunctioning part.

The mode applications for the "AIR BAG" warning lamp and CONSULT are as follows:

	User mode	Diagnosis mode	Display type
"AIR BAG" warning lamp	X	X	ON-OFF operation
CONSULT	—	X	Monitoring

HOW TO PERFORM TROUBLE DIAGNOSES FOR QUICK AND ACCURATE REPAIR

A good understanding of the malfunction conditions can make troubleshooting faster and more accurate.

In general, each customer feels differently about a malfunction. It is important to fully understand the symptoms or conditions for a customer complaint.

Information From Customer

WHAT - Vehicle model

WHEN - Date, Frequencies

WHERE - Road conditions

HOW - Operating conditions, Symptoms

Preliminary Check

Check that the following parts are in good order.

- Battery (Refer to [SC-5, "How to Handle Battery"](#).)
- Fuses (Refer to [SRS-11, "Schematic"](#).)
- System component-to-harness connections

WORK FLOW

TROUBLE DIAGNOSIS

< SYMPTOM DIAGNOSIS >

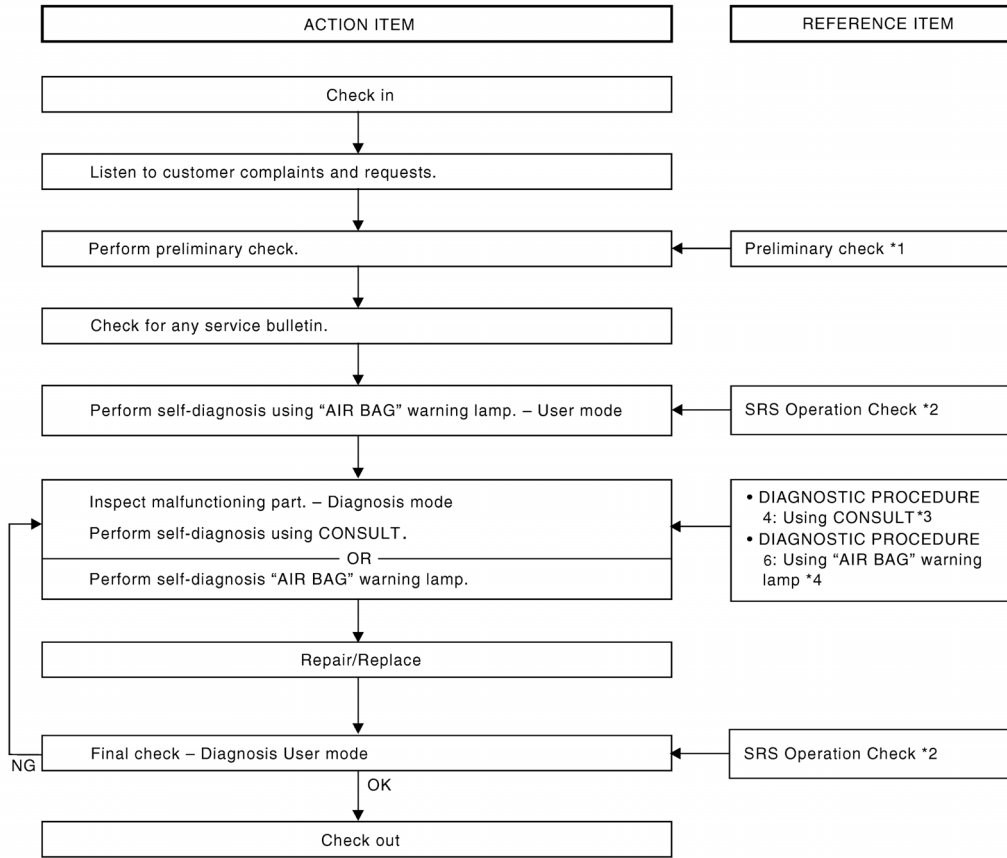

A
B
C
D
E
F
G
SRS
I
J
K
L
M
N
O
P

AWHIA0310GB

*1: "PRELIMINARY CHECK"

*2: [SRS-19](#)

*3: [SRS-20](#)

*4: [SRS-28](#)

TROUBLE DIAGNOSIS

< SYMPTOM DIAGNOSIS >

SRS Component Parts Location

INFOID:000000007330546

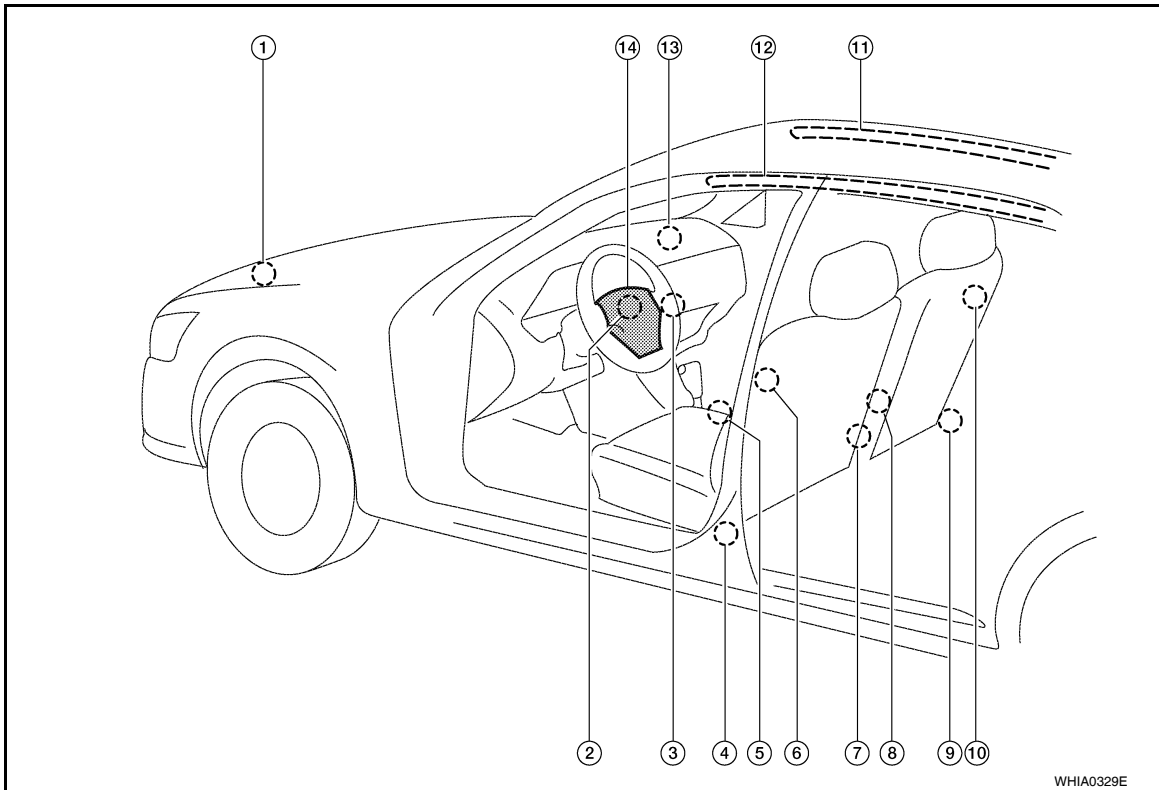

- | | | |
|---|--|--|
| 1. Crash zone sensor | 2. Spiral cable | 3. Front passenger air bag off indicator |
| 4. Front LH seat belt pre-tensioner
LH side air bag (satellite) sensor | 5. Air bag diagnosis sensor unit | 6. Front LH side air bag module |
| 7. Seat belt buckle switch (LH)
Seat belt buckle switch (RH) | 8. Occupant classification system control
unit
Occupant classification system sensor | 9. Front RH seat belt pre-tensioner
RH side air bag (satellite) sensor
Belt tension sensor |
| 10. Front RH side air bag module | 11. RH side curtain air bag module | 12. LH side curtain air bag module |
| 13. Front passenger air bag module | 14. Driver air bag module | |

TROUBLE DIAGNOSIS

< SYMPTOM DIAGNOSIS >

Schematic

INFOID:000000007330547

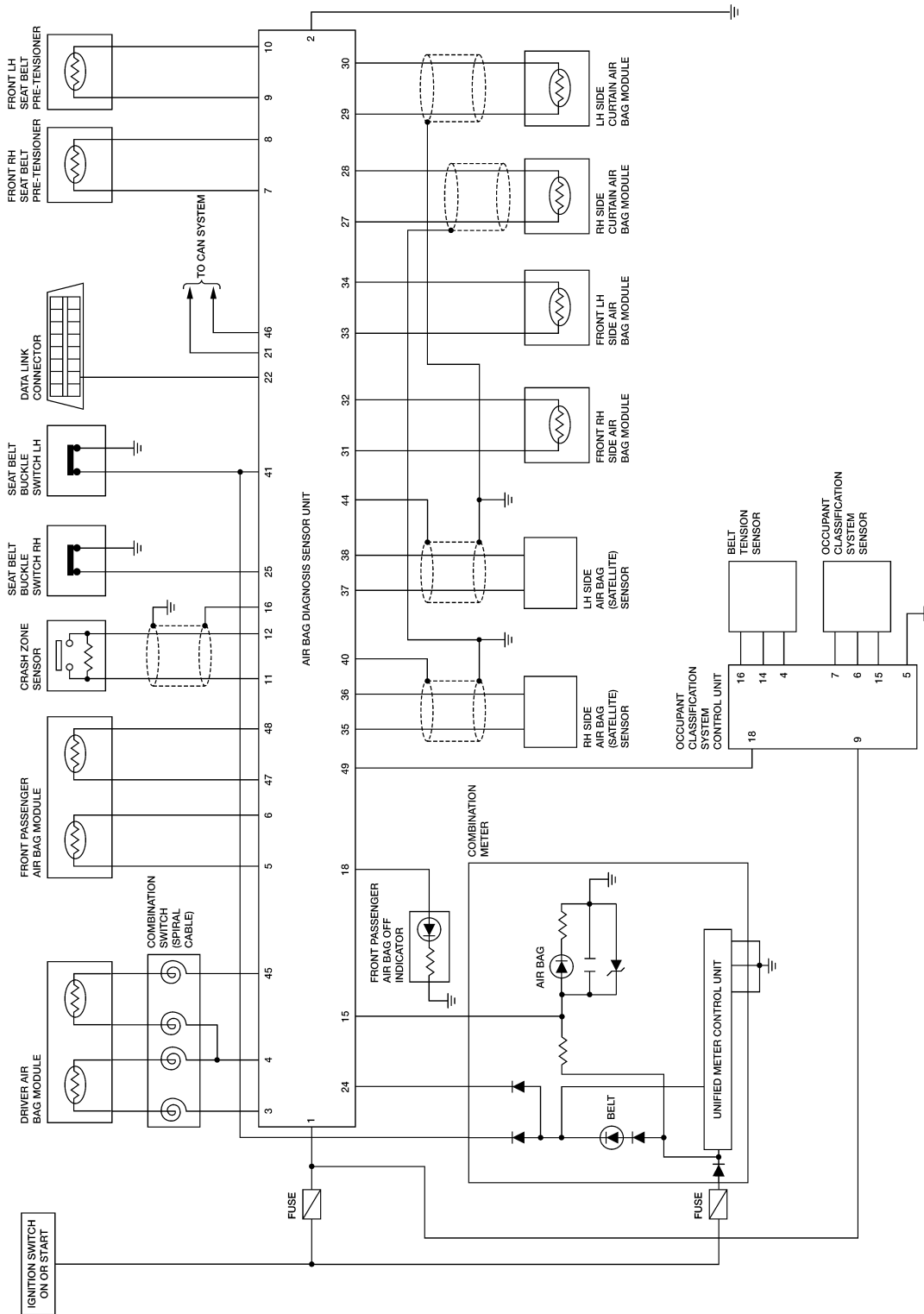

ABHWA0108GB

A
B
C
D
E
F
G
SRS
I
J
K
L
M
N
O
P

TROUBLE DIAGNOSIS

< SYMPTOM DIAGNOSIS >

Wiring Diagram - SRS-

INFOID:000000007330548

SRS-SRS-01

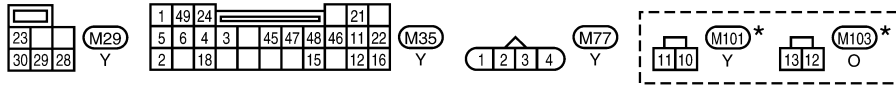
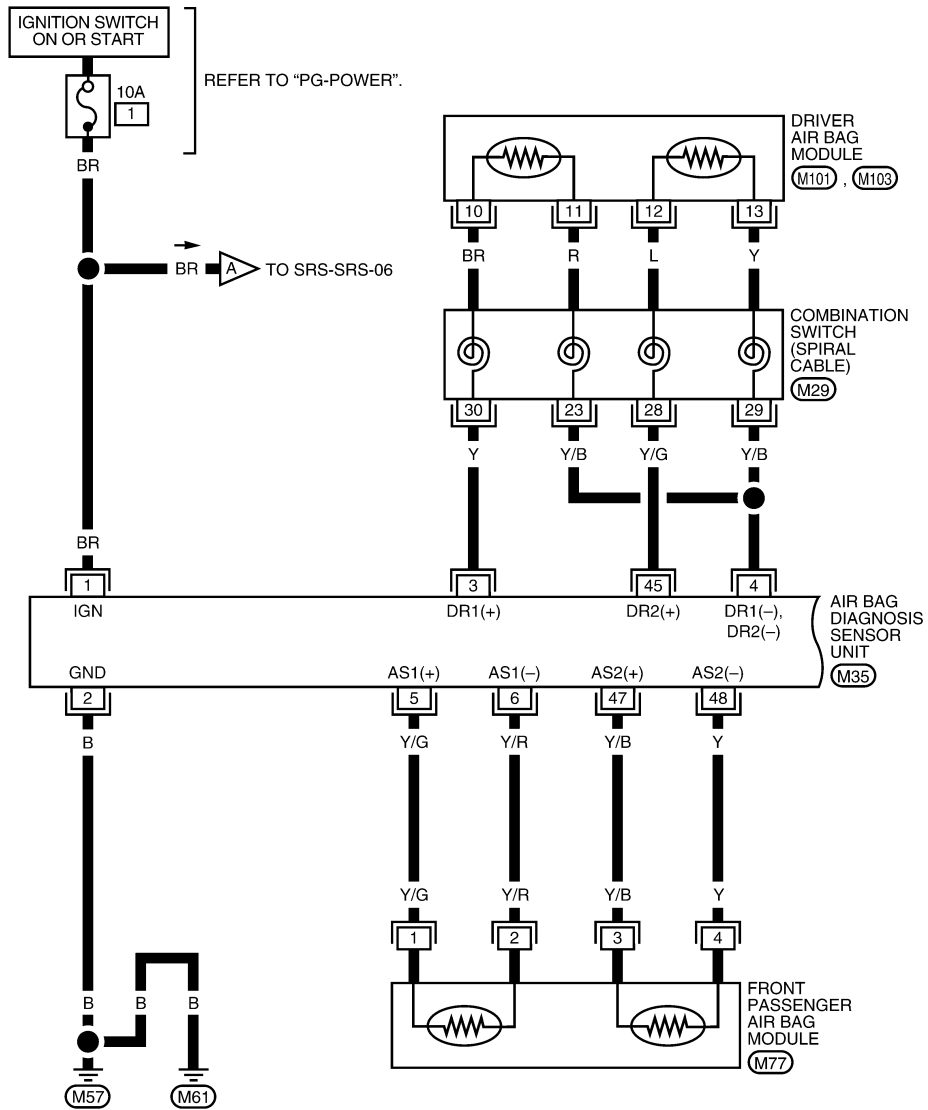

* : THIS CONNECTOR IS NOT SHOWN IN "HARNESS LAYOUT" OF PG SECTION.

ABHWA0109GB

TROUBLE DIAGNOSIS

< SYMPTOM DIAGNOSIS >

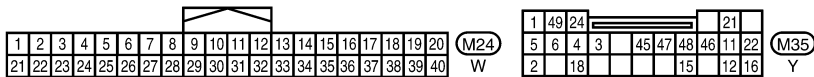
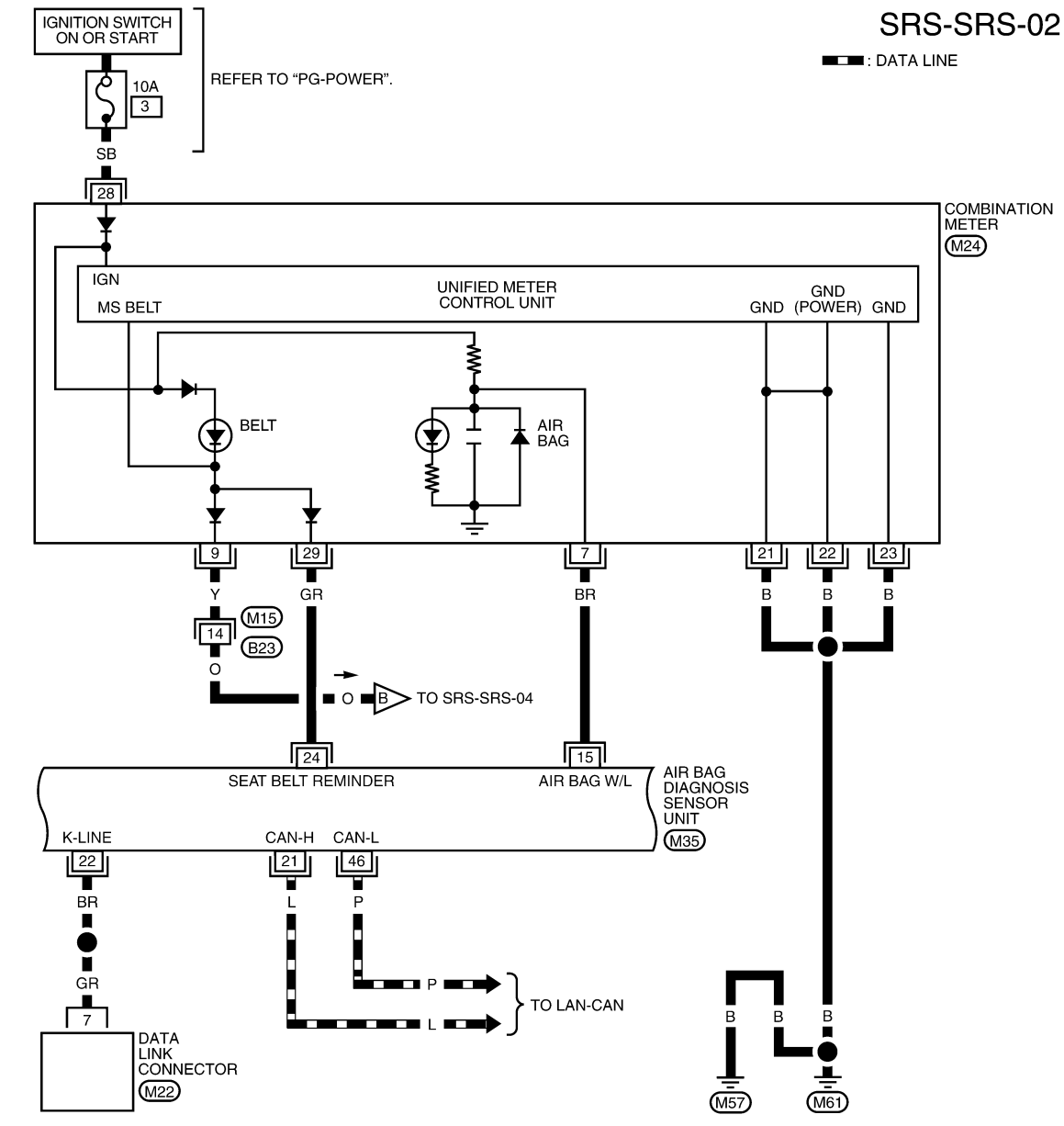

ABHWA0110GB

TROUBLE DIAGNOSIS

< SYMPTOM DIAGNOSIS >

SRS-SRS-03

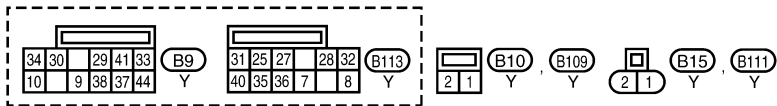
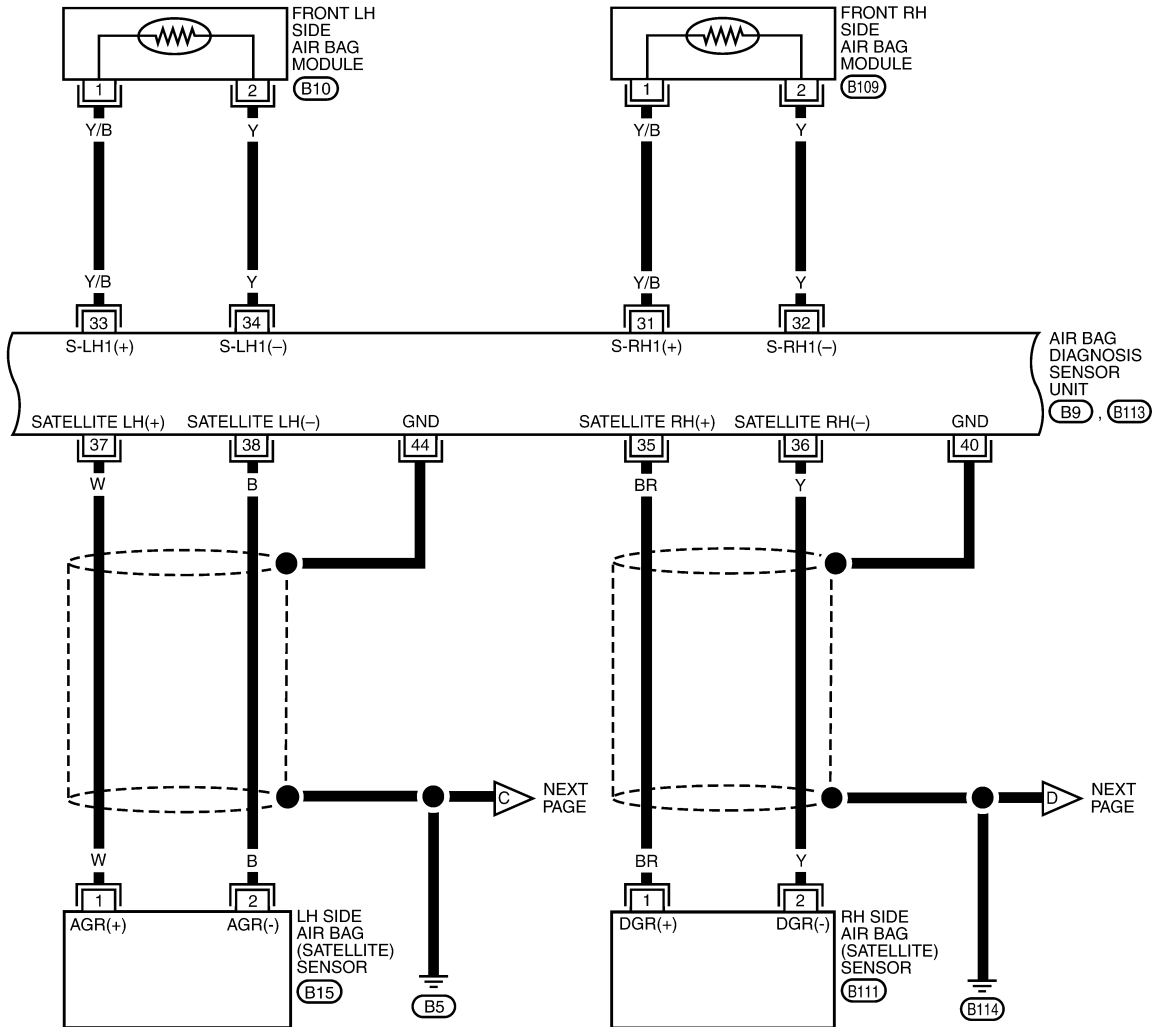

WHWA0299E

TROUBLE DIAGNOSIS

< SYMPTOM DIAGNOSIS >

SRS-SRS-04

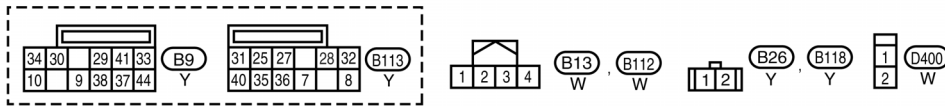
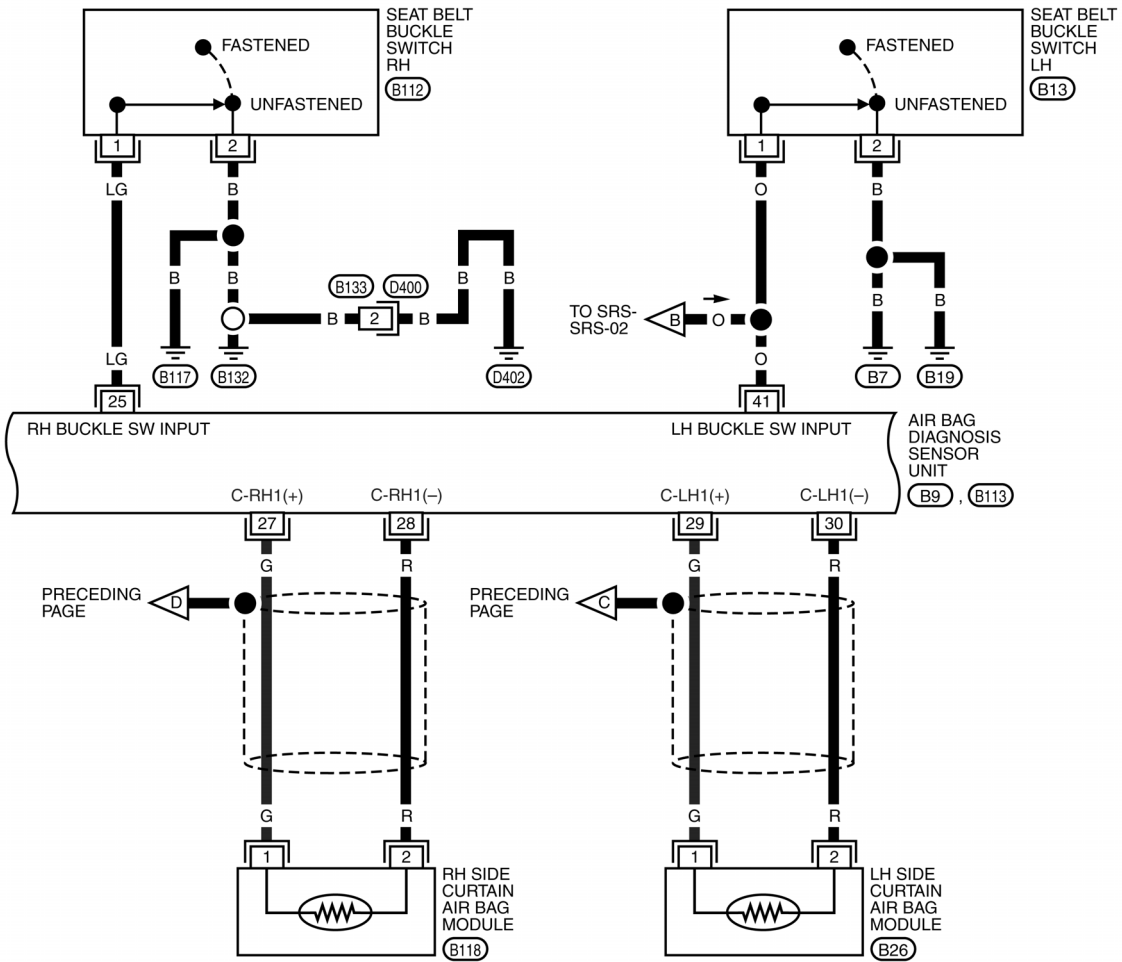

AAHWA0032GB

TROUBLE DIAGNOSIS

< SYMPTOM DIAGNOSIS >

SRS-SRS-05

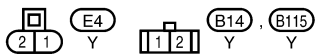
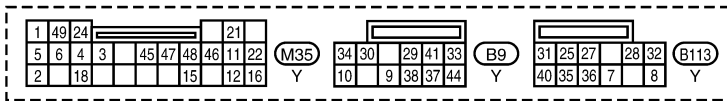
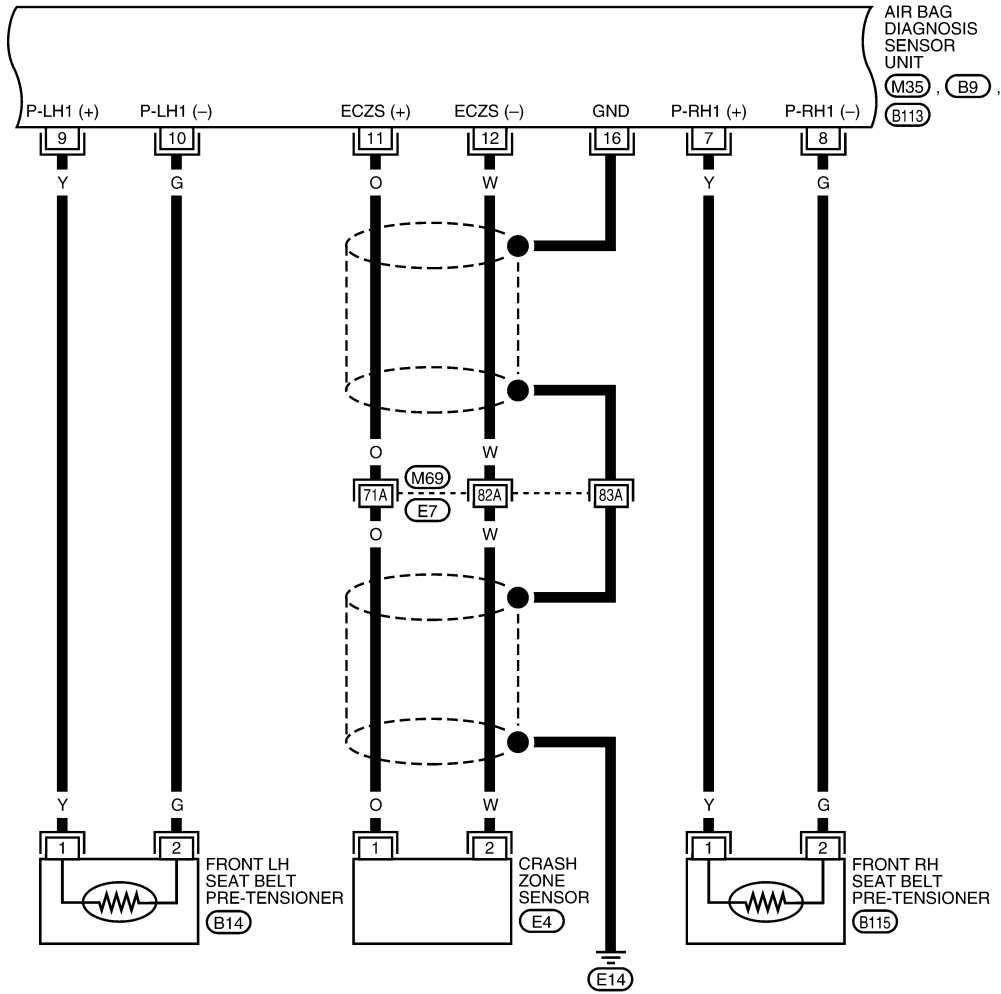

REFER TO THE FOLLOWING.
 (M69) - SUPER MULTIPLE JUNCTION (SMJ)

ABHWA0112GB

TROUBLE DIAGNOSIS

< SYMPTOM DIAGNOSIS >

SRS-SRS-06

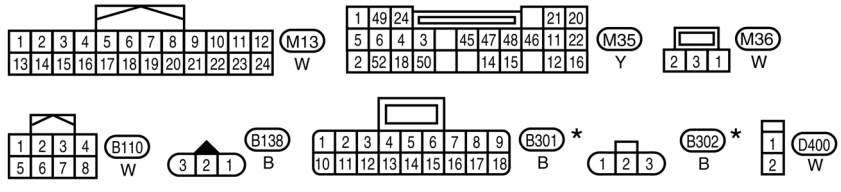
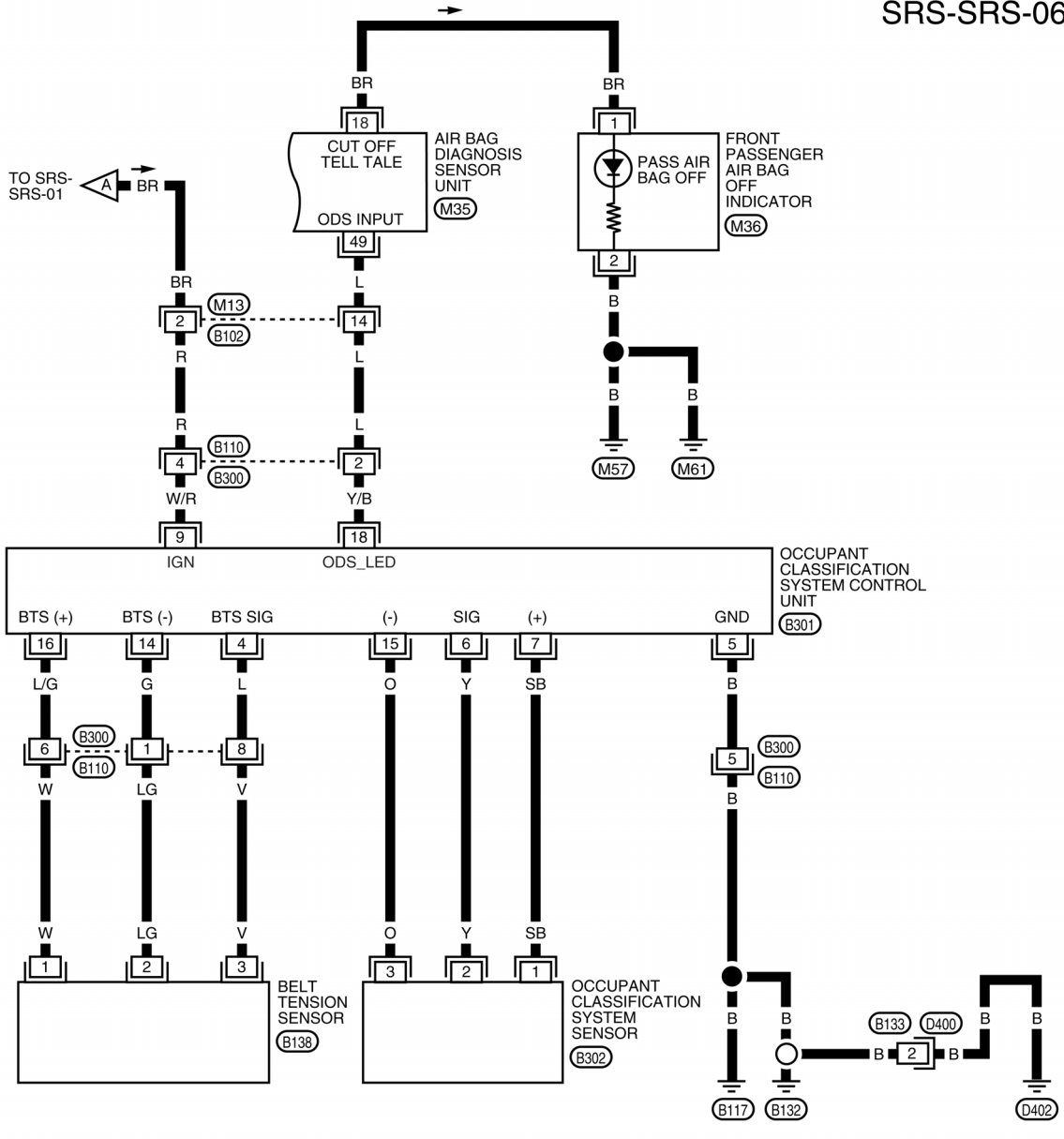

*: THIS CONNECTOR IS NOT SHOWN IN "HARNESS LAYOUT" OF PG SECTION.

AAHWA0033GB

CONSULT Function (AIR BAG)

INFOID:000000007330549

CONSULT can display each diagnostic item using the diagnostic test modes shown following.

TROUBLE DIAGNOSIS

< SYMPTOM DIAGNOSIS >

AIR BAG diagnostic mode	Description
SELF-DIAG [CURRENT]	A current Self-diagnosis result is displayed on the CONSULT screen in real time. This refers to a malfunctioning part requiring replacement.
SELF-DIAG [PAST]	Diagnosis results previously stored in the memory are displayed on the CONSULT screen. The stored results will remain until the memory is erased.
TROUBLE DIAG RECORD	With TROUBLE DIAG RECORD, diagnosis results previously erased by a reset operation can be displayed on the CONSULT screen.
ECU DISCRIMINATED NO.	Air bag diagnosis sensor unit ECU discriminated number (identification number) or part number is displayed. Air bag diagnosis sensor unit has individual ECU discriminated number (identification number) or part number based on model and equipment.
PASSENGER AIR BAG	The STATUS (readiness) of the front passenger air bag module is displayed. The STATUS displayed (ON/OFF) depends on the signals supplied to the occupant classification system control module and air bag diagnosis sensor unit. Refer to SRS-6, "Occupant Classification System (OCS)" for more information.

HOW TO CHANGE BETWEEN SELF-DIAGNOSIS MODE AND USER MODE WITH CONSULT

From User Mode to Diagnosis Mode

After selecting "AIR BAG" on the "SELECT SYSTEM" screen, User mode automatically changes to Diagnosis mode.

From Diagnosis Mode to User Mode

To return to User mode from Diagnosis mode, touch "BACK" key of CONSULT until "SELECT SYSTEM" appears, Diagnosis mode automatically changes to User mode.

HOW TO ERASE SELF-DIAGNOSIS RESULTS

NOTE:

If the memory in "SELF-DIAG [PAST]" is not erased, User mode will continue to show the system malfunction by the operation of the warning lamp even if the malfunction is repaired completely.

- "SELF-DIAG [CURRENT]"
A current self-diagnosis result is displayed on the CONSULT screen in real time. After the malfunction is repaired completely, no malfunction is detected on "SELF-DIAG [CURRENT]".
- "SELF-DIAG [PAST]"
Return to the "SELF-DIAG [CURRENT]" CONSULT screen by touching "BACK" key of CONSULT and select "SELF-DIAG [CURRENT]" in SELECT DIAG MODE. Touch "ERASE" in "SELF-DIAG [CURRENT]" mode.
- "TROUBLE DIAG RECORD"
The memory of "TROUBLE DIAG RECORD" cannot be erased.

Self-Diagnosis Function (Without CONSULT)

INFOID:000000007330550

The reading of these results is accomplished using one of two modes —"User mode" and "Diagnosis mode".

TROUBLE DIAGNOSIS

< SYMPTOM DIAGNOSIS >

HOW TO CHANGE BETWEEN USER MODE AND SELF-DIAGNOSIS MODE WITHOUT CONSULT

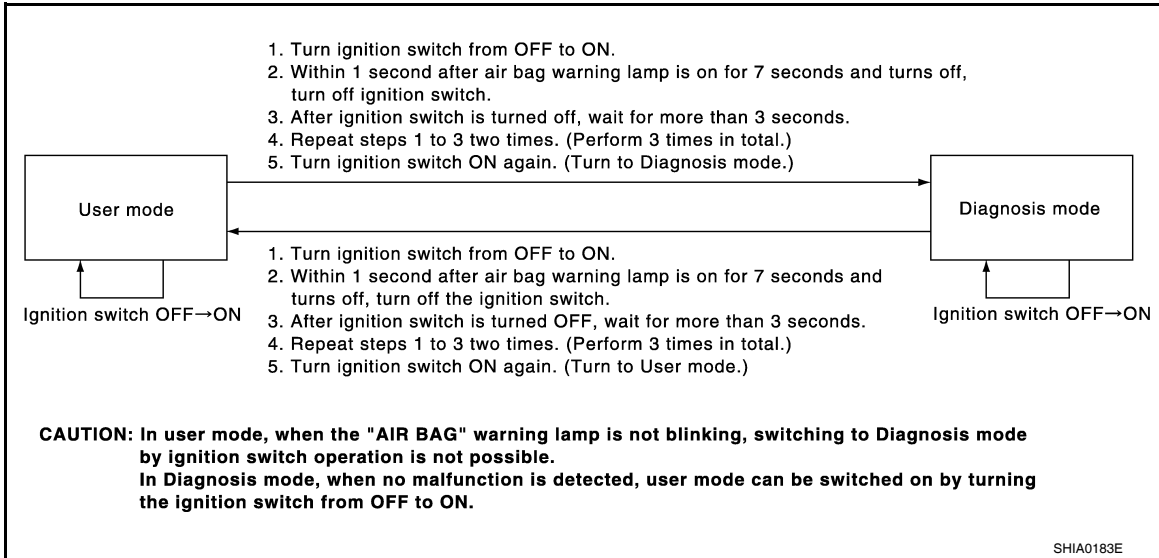

HOW TO ERASE SELF-DIAGNOSIS RESULTS

After a malfunction is repaired, turn the ignition switch OFF for at least one second, then back ON. Diagnosis mode returns to the User mode. At that time, the self-diagnostic result is cleared.

SRS Operation Check

INFOID:000000007330551

SRS

DIAGNOSTIC PROCEDURE 1

Checking SRS Operation Using "AIR BAG" Warning Lamp—User Mode



1. Turn the ignition switch from OFF to ON, and check that the air bag warning lamp blinks.
2. Compare the SRS air bag warning lamp blinking pattern with the examples.



TROUBLE DIAGNOSIS

< SYMPTOM DIAGNOSIS >

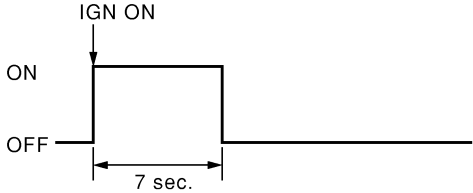
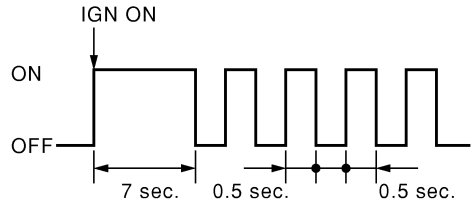
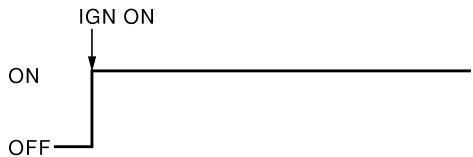
Air bag warning lamp examples

"AIR BAG" warning lamp operation-User mode-	SRS condition	Reference item
 <p style="text-align: right;">SHIA0011E</p>	<ul style="list-style-type: none"> No malfunction is detected. No further action is necessary. 	<p style="text-align: center;">—</p>
 <p style="text-align: right;">SHIA0012E</p>	<ul style="list-style-type: none"> The system is malfunctioning and needs to be repaired as indicated. 	<p>Go to SRS-20, "Trouble Diagnosis with CONSULT" with CONSULT or SRS-28, "Trouble Diagnosis without CONSULT" without CONSULT.</p>
 <p style="text-align: right;">SHIA0013E</p>	<ul style="list-style-type: none"> Air bag is deployed. Seat belt pre-tensioner is deployed. Air bag diagnosis sensor unit is malfunctioning. Air bag power supply circuit is malfunctioning. Air bag warning lamp circuit is malfunctioning. 	<p>Go to SRS-49, "For Frontal Collision".</p> <p>Go to SRS-32, "Trouble Diagnosis: "AIR BAG" Warning Lamp Does Not Turn Off".</p>
 <p style="text-align: right;">SHIA0014E</p>	<ul style="list-style-type: none"> Air bag diagnosis sensor unit is malfunctioning. Air bag warning lamp circuit is malfunctioning. 	<p>Go to SRS-32, "Trouble Diagnosis: "AIR BAG" Warning Lamp Does Not Turn On".</p>

Trouble Diagnosis with CONSULT

INFOID:000000007330552

DIAGNOSTIC PROCEDURE 2

Diagnostic code is displayed on "SELF-DIAG [CURRENT]".

If no malfunction is detected on "SELF-DIAG [CURRENT]", but malfunction is detected in "SRS Operation Check", the following cases may exist:

- "SELF-DIAG [PAST]" memory might not be erased.
- The SRS system malfunctions intermittently.

Refer to "DIAGNOSTIC PROCEDURE 4"

TROUBLE DIAGNOSIS

< SYMPTOM DIAGNOSIS >

CONSULT Diagnostic Code Chart ("SELF-DIAG [CURRENT]")

Diagnostic item	Explanation		Repair order Recheck SRS at each replacement
NO DTC IS DETECTED	Malfunction is indicated by the "AIR BAG" warning lamp in User mode.	Low battery voltage (Less than 9V)	<ol style="list-style-type: none"> 1. Go to SC-5. "How to Handle Battery". 2. Go to "DIAGNOSTIC PROCEDURE 3".
		"SELF-DIAG [PAST]" memory might not be erased.	Go to "DIAGNOSTIC PROCEDURE 4".
		Intermittent malfunction has been detected in the past.	Go to "DIAGNOSTIC PROCEDURE 5".
	No malfunction is detected in User mode.		—
DRIVER AIRBAG MODULE [OPEN] [B1049] or [B1054]	Driver air bag module circuit is open (including the spiral cable).		<ol style="list-style-type: none"> 1. Visually check the wiring harness connection. 2. Replace the harness if it has visible damage.
DRIVER AIRBAG MODULE [VB-SHORT] [B1050] or [B1055]	Driver air bag module circuit is shorted to some power supply circuit (including the spiral cable).		<ol style="list-style-type: none"> 3. Inspect spiral cable circuit. 4. Replace the air bag diagnosis sensor unit.
DRIVER AIRBAG MODULE [GND-SHORT] [B1051] or [B1056]	Driver air bag module circuit is shorted to ground (including the spiral cable).		<ol style="list-style-type: none"> 5. Replace driver air bag module. 6. Replace the related harness.
DRIVER AIRBAG MODULE [SHORT] [B1052] or [B1057]	Driver air bag module circuits are shorted to each other.		
ASSIST A/B MODULE [OPEN] [B1065] or [B1070]	Front passenger air bag module circuit is open.		<ol style="list-style-type: none"> 1. Visually check the wiring harness connection. 2. Replace the harness if it has visible damage.
ASSIST A/B MODULE [VB-SHORT] [B1066] or [B1071]	Front passenger air bag module circuit is shorted to some power supply circuit.		<ol style="list-style-type: none"> 3. Replace the air bag diagnosis sensor unit. 4. Replace front passenger air bag module.
ASSIST A/B MODULE [GND-SHORT] [B1067] or [B1072]	Front passenger air bag module circuit is shorted to ground.		<ol style="list-style-type: none"> 5. Replace the related harness.
ASSIST A/B MODULE [SHORT] [B1068] or [B1073]	Front passenger air bag module circuits are shorted to each other.		
CRASH ZONE SEN [UNIT FAIL] [B1033] or [B1034] CRASH ZONE SEN [COMM FAIL] [B1035]	Crash zone sensor		<ol style="list-style-type: none"> 1. Visually check the wiring harness connection. 2. Replace the harness if it has visible damage. 3. Replace the crash zone sensor. 4. Replace the air bag diagnosis sensor unit. 5. Replace the related harness.
SIDE MODULE LH [OPEN] [B1134]	Front LH side air bag module circuit is open.		<ol style="list-style-type: none"> 1. Visually check the wiring harness connection. 2. Replace the harness if it has visible damage.
SIDE MODULE LH [VB-SHORT] [B1135]	Front LH side air bag module circuit is shorted to some power supply circuit.		<ol style="list-style-type: none"> 3. Replace the air bag diagnosis sensor unit. 4. Replace front LH side air bag module.
SIDE MODULE LH [GND-SHORT] [B1136]	Front LH side air bag module circuit is shorted to ground.		<ol style="list-style-type: none"> 5. Replace the related harness.
SIDE MODULE LH [SHORT] [B1137]	Front LH side air bag module circuits are shorted to each other.		

A

B

C

D

E

F

G

SRS

I

J

K

L

M

N

O

P

TROUBLE DIAGNOSIS

< SYMPTOM DIAGNOSIS >

Diagnostic item	Explanation	Repair order Recheck SRS at each replacement
SIDE MODULE RH [OPEN] [B1129]	Front RH side air bag module circuit is open.	<ol style="list-style-type: none"> 1. Visually check the wiring harness connection. 2. Replace the harness if it has visible damage. 3. Replace the air bag diagnosis sensor unit. 4. Replace front RH side air bag module. 5. Replace the related harness.
SIDE MODULE RH [VB-SHORT] [B1130]	Front RH side air bag module circuit is shorted to some power supply circuit.	
SIDE MODULE RH [GND-SHORT] [B1131]	Front RH side air bag module circuit is shorted to ground.	
SIDE MODULE RH [SHORT] [B1132]	Front RH side air bag module circuits are shorted to each other.	
SATELLITE SENS LH [UNIT FAIL] [B1118] or [B1119] SATELLITE SENS LH [COMM FAIL] [B1120]	LH side air bag (satellite) sensor	<ol style="list-style-type: none"> 1. Visually check the wiring harness connection. 2. Replace the harness if it has visible damage. 3. Replace the LH side air bag (satellite) sensor. 4. Replace the air bag diagnosis sensor unit. 5. Replace the related harness.
SATELLITE SENS RH [UNIT FAIL] [B1113] or [B1114] SATELLITE SENS RH [COMM FAIL] [B1115]	RH side air bag (satellite) sensor	<ol style="list-style-type: none"> 1. Visually check the wiring harness connection. 2. Replace the harness if it has visible damage. 3. Replace the RH side air bag (satellite) sensor. 4. Replace the air bag diagnosis sensor unit. 5. Replace the related harness.
PRE-TEN FRONT LH [OPEN] [B1086]	The circuit for front LH seat belt pre-tensioner is open.	<ol style="list-style-type: none"> 1. Visually check the wiring harness connections. 2. Replace the harness if it has visible damage. 3. Replace front LH seat belt pre-tensioner. 4. Replace the air bag diagnosis sensor unit. 5. Replace the related harness.
PRE-TEN FRONT LH [VB-SHORT] [B1087]	The circuit for front LH seat belt pre-tensioner is shorted to some power supply circuit.	
PRE-TEN FRONT LH [GND-SHORT] [B1088]	The circuit for front LH seat belt pre-tensioner is shorted to ground.	
PRE-TEN FRONT LH [SHORT] [B1089]	The circuits for the front LH seat belt pre-tensioner are shorted to each other.	
PRE-TEN FRONT RH [OPEN] [B1081]	The circuit for front RH seat belt pre-tensioner is open.	<ol style="list-style-type: none"> 1. Visually check the wiring harness connections. 2. Replace the harness if it has visible damage. 3. Replace front RH seat belt pre-tensioner. 4. Replace the air bag diagnosis sensor unit. 5. Replace the related harness.
PRE-TEN FRONT RH [VB-SHORT] [B1082]	The circuit for front RH seat belt pre-tensioner is shorted to some power supply circuit.	
PRE-TEN FRONT RH [GND-SHORT] [B1083]	The circuit for front RH seat belt pre-tensioner is shorted to ground.	
PRE-TEN FRONT RH [SHORT] [B1084]	The circuits for the front RH seat belt pre-tensioner are shorted to each other.	

TROUBLE DIAGNOSIS

< SYMPTOM DIAGNOSIS >

Diagnostic item	Explanation	Repair order Recheck SRS at each replacement	
CURTAIN MODULE LH [OPEN] [B1150]	The LH side curtain air bag module circuit is open.	<ol style="list-style-type: none"> 1. Visually check the wiring harness connection. 2. Replace the harness if it has visible damage. 3. Replace the air bag diagnosis sensor unit. 4. Replace LH side curtain air bag module. 5. Replace the related harness. 	A
CURTAIN MODULE LH [VB-SHORT] [B1151]	The LH side curtain air bag module circuit is shorted to some power supply circuits.		B
CURTAIN MODULE LH [GND-SHORT] [B1152]	The LH side curtain air bag module circuit is shorted to ground.		C
CURTAIN MODULE LH [SHORT] [B1153]	The circuits for the LH side curtain air bag module are shorted to each other.		D
CURTAIN MODULE RH [OPEN] [B1145]	The RH side curtain air bag module circuit is open.	<ol style="list-style-type: none"> 1. Visually check the wiring harness connection. 2. Replace the harness if it has visible damage. 3. Replace the air bag diagnosis sensor unit. 4. Replace RH side curtain air bag module. 5. Replace the related harness. 	E
CURTAIN MODULE RH [VB-SHORT] [B1146]	The RH side curtain air bag module circuit is shorted to some power supply circuits.		F
CURTAIN MODULE RH [GND-SHORT] [B1147]	The RH side curtain air bag module circuit is shorted to ground.		G
CURTAIN MODULE RH [SHORT] [B1148]	The circuits for the RH side curtain air bag module are shorted to each other.		SRS
CONTROL UNIT [B1XXX]	Air bag diagnosis sensor unit is malfunctioning.		<ol style="list-style-type: none"> 1. Visually check the wiring harness connection. 2. Replace the air bag diagnosis sensor unit.
OCCUPANT SENS C/U [UNIT FAIL] [B1017] or [B1021]	The OCS control unit is malfunctioning.	<ol style="list-style-type: none"> 1. Replace RH front seat cushion/occupant classification system control unit assembly. 	J
OCCUPANT SENS C/U [UNIT FAIL] [B1020]	The OCS control unit is malfunctioning.	<ol style="list-style-type: none"> 1. Replace the harness if it has visible damage. 2. Replace the RH front seat cushion assembly. Do not disassemble the seat cushion assembly. 3. Replace the RH front seat belt assembly. 	K L
OCCUPANT SENS C/U [COMM FAIL] [B1022]	Communication between the OCS control unit and air bag diagnosis sensor unit is interrupted.	<ol style="list-style-type: none"> 1. Visually check the wiring harness connection. 2. Replace the harness if it has visible damage. 3. Replace the RH front seat cushion assembly. Do not disassemble the seat cushion assembly. 4. Replace the air bag diagnosis sensor unit. 5. Replace the related harness. 	M N O
OCCUPANT SENS [UNIT FAIL] [B1018]	OCS sensor is malfunctioning.	<ol style="list-style-type: none"> 1. Visually check the wiring harness connection to the OCS sensor. 2. Replace the RH front seat cushion assembly. Do not disassemble the seat cushion assembly. 	P

TROUBLE DIAGNOSIS

< SYMPTOM DIAGNOSIS >

Diagnostic item	Explanation	Repair order Recheck SRS at each replacement
BELT TENSION SENS [UNIT FAIL] [B1019]	Belt tension sensor is malfunctioning.	<ol style="list-style-type: none"> 1. Visually check the wiring harness connection. 2. Replace the harness if it has visible damage. 3. Replace the RH front seat belt assembly. 4. Replace the RH front seat cushion assembly. Do not disassemble the seat cushion assembly. 5. Replace the related harness.
FRONTAL COLLISION DETECTION [B1209]	Driver and front passenger air bag modules are deployed.	Refer to SRS-49, "For Frontal Collision" .
SIDE COLLISION DETECTION [B1210]	Side or curtain air bag modules are deployed.	Refer to SRS-51, "For Side and Roll-over Collision" .

NOTE:

Follow the procedures in numerical order when performing repairs. Confirm whether the repair has been successful using air bag warning lamp or CONSULT after each repair. If malfunction is still observed, proceed to the next step. When malfunction has been eliminated, further repair work is not required.

DIAGNOSTIC PROCEDURE 3

Final Check of SRS Using CONSULT—Diagnosis Mode

1. If no DTC is detected on "SELF-DIAG [CURRENT]", repair of SRS is completed. Go to step 2.
If any DTC is detected on "SELF-DIAG [CURRENT]", the malfunctioning part has not been repaired completely or another malfunctioning part is being detected. Go to "DIAGNOSTIC PROCEDURE 2".
2. Touch "ERASE".
NOTE:
Touch "ERASE" to clear the memory of the malfunction ("SELF-DIAG [PAST]").
If the memory of the malfunction in "SELF-DIAG [PAST]" is not erased, the User mode shows the system malfunction by the operation of the warning lamp even if the malfunction is repaired completely.
3. Touch "BACK" key of CONSULT to "SELECT DIAG MODE" screen. Touch "SELF-DIAG [PAST]".
4. Check that no malfunction is detected on "SELF-DIAG [PAST]".
5. Touch "BACK" key of CONSULT until "SELECT SYSTEM" appears in order to return to User mode from Diagnosis mode.
6. Turn ignition switch OFF then turn off and disconnect CONSULT.
7. Go to [SRS-19, "SRS Operation Check"](#).

DIAGNOSTIC PROCEDURE 4

Check SRS Repair History

1. CONSIDER POSSIBILITY THAT SELF-DIAGNOSTIC RESULT WAS NOT ERASED AFTER REPAIR

Check repair history of the SRS.

Have any previous repairs been made to the SRS?

- Yes >> Self-diagnostic result "SELF-DIAG [PAST]" (previously stored in the memory) might not be erased after repair. Go to "DIAGNOSTIC PROCEDURE 3".
- No >> Go to "DIAGNOSTIC PROCEDURE 2".

DIAGNOSTIC PROCEDURE 5

Check SRS Intermittent Malfunction Using CONSULT—Diagnosis Mode

1. If diagnostic codes are displayed on "SELF-DIAG [PAST]", go to step 4.
If no malfunction is detected on "SELF-DIAG [PAST]", touch "BACK" and go back to "SELECT DIAG MODE".

TROUBLE DIAGNOSIS

< SYMPTOM DIAGNOSIS >

2. Touch "TROUBLE DIAG RECORD".
NOTE:
With "TROUBLE DIAG RECORD", diagnosis results previously erased by a reset operation can be displayed.
3. Diagnostic code is displayed on "TROUBLE DIAG RECORD".
4. Touch "PRINT".
5. Compare diagnostic codes to "CONSULT Diagnostic Code Chart ("SELF-DIAG [PAST]" or "TROUBLE DIAG RECORD")".
6. Touch "BACK" key of CONSULT until "SELECT SYSTEM" appears.
7. Turn ignition switch OFF, then turn off and disconnect CONSULT, and both battery cables.
8. Repair the system as outlined by the "Repair order" in "Intermittent Malfunction Diagnostic Code Chart", that corresponds to the self-diagnostic result. For replacement procedure of component parts, refer to the Removal and Installation procedure for the appropriate component.
9. Go to "DIAGNOSTIC PROCEDURE 3", for final checking.

CONSULT Diagnostic Code Chart ("SELF-DIAG [PAST]" or "TROUBLE DIAG RECORD")

Diagnostic item	Explanation	Repair order Recheck SRS at each replacement
NO DTC IS DETECTED	When malfunction is indicated by the "AIR BAG" warning lamp in User mode.	<ul style="list-style-type: none"> • Low battery voltage (Less than 9V) • Self-diagnostic result "SELF-DIAG [PAST]" (previously stored in the memory) might not be erased after repair. • Intermittent malfunction has been detected in the past.
	• No malfunction is detected.	—
DRIVER AIRBAG MODULE [OPEN] [B1049] or [B1054]	Driver air bag module circuit is open (including the spiral cable).	<ol style="list-style-type: none"> 1. Visually check the wiring harness connection. 2. Replace the harness if it has visible damage. 3. Inspect spiral cable circuit. 4. Replace the air bag diagnosis sensor unit. 5. Replace driver air bag module. 6. Replace the related harness.
DRIVER AIRBAG MODULE [VB-SHORT] [B1050] or [B1055]	Driver air bag module circuit is shorted to some power supply circuit (including the spiral cable).	
DRIVER AIRBAG MODULE [GND-SHORT] [B1051] or [B1056]	Driver air bag module circuit is shorted to ground (including the spiral cable).	
DRIVER AIRBAG MODULE [SHORT] [B1052] or [B1057]	Driver air bag module circuits are shorted to each other.	
ASSIST A/B MODULE [OPEN] [B1065] or [B1070]	Front passenger air bag module circuit is open.	<ol style="list-style-type: none"> 1. Visually check the wiring harness connection. 2. Replace the harness if it has visible damage. 3. Replace the air bag diagnosis sensor unit. 4. Replace front passenger air bag module. 5. Replace the related harness.
ASSIST A/B MODULE [VB-SHORT] [B1066] or [B1071]	Front passenger air bag module circuit is shorted to some power supply circuit.	
ASSIST A/B MODULE [GND-SHORT] [B1067] or [B1072]	Front passenger air bag module circuit is shorted to ground.	
ASSIST A/B MODULE [SHORT] [B1068] or [B1073]	Front passenger air bag module circuits are shorted to each other.	

TROUBLE DIAGNOSIS

< SYMPTOM DIAGNOSIS >

Diagnostic item	Explanation	Repair order Recheck SRS at each replacement
CRASH ZONE SEN [UNIT FAIL] [B1033] or [B1034] CRASH ZONE SEN [COMM FAIL] [B1035]	Crash zone sensor	<ol style="list-style-type: none"> 1. Visually check the wiring harness connection. 2. Replace the harness if it has visible damage. 3. Replace the crash zone sensor. 4. Replace the air bag diagnosis sensor unit. 5. Replace the related harness.
SIDE MODULE LH [OPEN] [B1134]	Front LH side air bag module circuit is open.	<ol style="list-style-type: none"> 1. Visually check the wiring harness connection. 2. Replace the harness if it has visible damage. 3. Replace the air bag diagnosis sensor unit. 4. Replace front LH side air bag module. 5. Replace the related harness.
SIDE MODULE LH [VB-SHORT] [B1135]	Front LH side air bag module circuit is shorted to some power supply circuit.	
SIDE MODULE LH [GND-SHORT] [B1136]	Front LH side air bag module circuit is shorted to ground.	
SIDE MODULE LH [SHORT] [B1137]	Front LH side air bag module circuits are shorted to each other.	
SIDE MODULE RH [OPEN] [B1129]	Front RH side air bag module circuit is open.	
SIDE MODULE RH [VB-SHORT] [B1130]	Front RH side air bag module circuit is shorted to some power supply circuit.	<ol style="list-style-type: none"> 1. Visually check the wiring harness connection. 2. Replace the harness if it has visible damage. 3. Replace the air bag diagnosis sensor unit. 4. Replace front RH side air bag module. 5. Replace the related harness.
SIDE MODULE RH [GND-SHORT] [B1131]	Front RH side air bag module circuit is shorted to ground.	
SIDE MODULE RH [SHORT] [B1132]	Front RH side air bag module circuits are shorted to each other.	
SATELLITE SENS LH [UNIT FAIL] [B1118] or [B1119] SATELLITE SENS LH [COMM FAIL] [B1120]	LH side air bag (satellite) sensor	
SATELLITE SENS RH [UNIT FAIL] [B1113] or [B1114] SATELLITE SENS RH [COMM FAIL] [B1115]	RH side air bag (satellite) sensor	<ol style="list-style-type: none"> 1. Visually check the wiring harness connection. 2. Replace the harness if it has visible damage. 3. Replace the RH side air bag (satellite) sensor. 4. Replace the air bag diagnosis sensor unit. 5. Replace the related harness.

TROUBLE DIAGNOSIS

< SYMPTOM DIAGNOSIS >

Diagnostic item	Explanation	Repair order Recheck SRS at each replacement	
PRE-TEN FRONT LH [OPEN] [B1086]	The circuit for front LH seat belt pre-tensioner is open.	<ol style="list-style-type: none"> 1. Visually check the wiring harness connections. 2. Replace the harness if it has visible damage. 3. Replace front LH seat belt pre-tensioner. 4. Replace the air bag diagnosis sensor unit. 5. Replace the related harness. 	A
PRE-TEN FRONT LH [VB-SHORT] [B1087]	The circuit for front LH seat belt pre-tensioner is shorted to some power supply circuit.		B
PRE-TEN FRONT LH [GND-SHORT] [B1088]	The circuit for front LH seat belt pre-tensioner is shorted to ground.		C
PRE-TEN FRONT LH [SHORT] [B1089]	The circuits for the front LH seat belt pre-tensioner are shorted to each other.		D
PRE-TEN FRONT RH [OPEN] [B1081]	The circuit for front RH seat belt pre-tensioner is open.	<ol style="list-style-type: none"> 1. Visually check the wiring harness connections. 2. Replace the harness if it has visible damage. 3. Replace front RH seat belt pre-tensioner. 4. Replace the air bag diagnosis sensor unit. 5. Replace the related harness. 	E
PRE-TEN FRONT RH [VB-SHORT] [B1082]	The circuit for front RH seat belt pre-tensioner is shorted to some power supply circuit.		F
PRE-TEN FRONT RH [GND-SHORT] [B1083]	The circuit for front RH seat belt pre-tensioner is shorted to ground.		G
PRE-TEN FRONT RH [SHORT] [B1084]	The circuits for the front RH seat belt pre-tensioner are shorted to each other.		SRS
CURTAIN MODULE LH [OPEN] [B1150]	The LH side curtain air bag module circuit is open.		<ol style="list-style-type: none"> 1. Visually check the wiring harness connection. 2. Replace the harness if it has visible damage. 3. Replace the air bag diagnosis sensor unit. 4. Replace LH side curtain air bag module. 5. Replace the related harness.
CURTAIN MODULE LH [VB-SHORT] [B1151]	The LH side curtain air bag module circuit is shorted to some power supply circuits.	J	
CURTAIN MODULE LH [GND-SHORT] [B1152]	The LH side curtain air bag module circuit is shorted to ground.	K	
CURTAIN MODULE LH [SHORT] [B1153]	The circuits for the LH side curtain air bag module are shorted to each other.	L	
CURTAIN MODULE RH [OPEN] [B1145]	The RH side curtain air bag module circuit is open.	<ol style="list-style-type: none"> 1. Visually check the wiring harness connection. 2. Replace the harness if it has visible damage. 3. Replace the air bag diagnosis sensor unit. 4. Replace RH side curtain air bag module. 5. Replace the related harness. 	M
CURTAIN MODULE RH [VB-SHORT] [B1146]	The RH side curtain air bag module circuit is shorted to some power supply circuits.		N
CURTAIN MODULE RH [GND-SHORT] [B1147]	The RH side curtain air bag module circuit is shorted to ground.		O
CURTAIN MODULE RH [SHORT] [B1148]	The circuits for the RH side curtain air bag module are shorted to each other.		P
CONTROL UNIT [B1XXX]	Air bag diagnosis sensor unit is malfunctioning.	<ol style="list-style-type: none"> 1. Visually check the wiring harness connection. 2. Replace the air bag diagnosis sensor unit. 	
OCCUPANT SENS C/U [UNIT FAIL] [B1017] or [B1021]	The OCS control unit is malfunctioning.	<ol style="list-style-type: none"> 1. Replace RH front seat cushion/occupant classification system control unit assembly. 	

TROUBLE DIAGNOSIS

< SYMPTOM DIAGNOSIS >

Diagnostic item	Explanation	Repair order Recheck SRS at each replacement
OCCUPANT SENS C/U [UNIT FAIL] [B1020]	The OCS control unit is malfunctioning.	<ol style="list-style-type: none"> 1. Replace the harness if it has visible damage. 2. Replace the RH front seat cushion assembly. Do not disassemble the seat cushion assembly. 3. Replace the RH front seat belt assembly.
OCCUPANT SENS C/U [COMM FAIL] [B1022]	Communication between the OCS control unit and air bag diagnosis sensor unit is interrupted.	<ol style="list-style-type: none"> 1. Visually check the wiring harness connection. 2. Replace the harness if it has visible damage. 3. Replace the RH front seat cushion assembly. Do not disassemble the seat cushion assembly. 4. Replace the air bag diagnosis sensor unit. 5. Replace the related harness.
OCCUPANT SENS [UNIT FAIL] [B1018]	OCS sensor is malfunctioning.	<ol style="list-style-type: none"> 1. Visually check the wiring harness connection to the OCS sensor. 2. Replace the RH front seat cushion assembly. Do not disassemble the seat cushion assembly.
BELT TENSION SENS [UNIT FAIL] [B1019]	Belt tension sensor is malfunctioning.	<ol style="list-style-type: none"> 1. Visually check the wiring harness connection. 2. Replace the harness if it has visible damage. 3. Replace the RH front seat belt assembly. 4. Replace the RH front seat cushion assembly. Do not disassemble the seat cushion assembly. 5. Replace the related harness.
PASS A/B INDCTR CKT [B1023]	Front passenger air bag off indicator is malfunctioning.	<ol style="list-style-type: none"> 1. Visually check the wiring harness connection. 2. Replace the harness if it has visible damage. 3. Replace front passenger air bag off indicator. 4. Replace the air bag diagnosis sensor unit. 5. Replace the related harness.
FRONTAL COLLISION DETECTION [B1209]	Driver and front passenger air bag modules are deployed.	Refer to SRS-49 . " For Frontal Collision ".
SIDE COLLISION DETECTION [B1210]	Side or curtain air bag modules are deployed.	Refer to SRS-51 . " For Side and Roll-over Collision ".

NOTE:

Follow the procedures in numerical order when performing repairs. Confirm whether the repair has been successful using air bag warning lamp or CONSULT after each repair. If malfunction is still observed, proceed to the next step. When malfunction has been eliminated, further repair work is not required.

Trouble Diagnosis without CONSULT

INFOID:000000007330553

DIAGNOSTIC PROCEDURE 6

Inspect SRS Malfunction Using "AIR BAG" Warning Lamp—Diagnosis Mode

NOTE:

SRS will not enter Diagnosis mode if no malfunction is detected in User mode.

1. Turn ignition switch ON.

TROUBLE DIAGNOSIS

< SYMPTOM DIAGNOSIS >

2. After "AIR BAG" warning lamp lights for 7 seconds, turn ignition switch OFF within 1 second.
3. Wait more than 3 seconds.
4. Repeat steps 1 to 3 two times.
5. Turn ignition switch ON.

SRS is now in Diagnosis mode.

"AIR BAG" warning lamp operates in Diagnosis mode according to the Warning Lamp Flash Code Chart:

WARNING LAMP FLASH CODE CHART

<Diagnosis results (previously stored in the memory) might not be erased after repair or intermittent malfunctions have been detected in the past.>	
Flash pattern	Repair order
<p>a through b are repeated.</p> <p style="text-align: right;">SHIA0026E</p>	<ol style="list-style-type: none"> 1. Go to DIAGNOSTIC PROCEDURES 2 and 3.
<Driver air bag module>	
Flash pattern	Repair order
<p>a through d are repeated. d: Two flashes indicate malfunctioning driver air bag module circuits.</p> <p style="text-align: right;">AWHIA0311GB</p>	<ol style="list-style-type: none"> 1. Visually check the wiring harness connection. 2. Replace the harness if it has visible damage. 3. Inspect spiral cable circuit. 4. Replace the air bag diagnosis sensor unit. 5. Replace driver air bag module. 6. Replace the related harness.
<Air bag diagnosis sensor unit>	
Flash pattern	Repair order
<p>a through d are repeated. d: Seven flashes indicate malfunctioning diagnosis sensor unit circuit.</p> <p style="text-align: right;">WHIA0198E</p>	<ol style="list-style-type: none"> 1. Visually check the wiring harness connections. 2. Replace the harness if it has visible damage. 3. Replace the air bag diagnosis sensor unit. 4. Replace the related harness.
<Front passenger air bag module>	
Flash pattern	Repair order
<p>a through d are repeated. d: Eight flashes indicate malfunctioning front passenger air bag module circuit.</p> <p style="text-align: right;">AWHIA0312GB</p>	<ol style="list-style-type: none"> 1. Visually check the wiring harness connection. 2. Replace the harness if it has visible damage. 3. Replace the air bag diagnosis sensor unit. 4. Replace front passenger air bag module. 5. Replace the related harness.

A
B
C
D
E
F
G
H
I
J
K
L
M
N
O
P

SRS

TROUBLE DIAGNOSIS

< SYMPTOM DIAGNOSIS >

<Crash zone sensor>	
Flash pattern	Repair order
<p>a through d are repeated. d: Six flashes indicate malfunctioning crash zone sensor circuit.</p>	<ol style="list-style-type: none"> 1. Visually check the wiring harness connection. 2. Replace the harness if it has visible damage. 3. Replace the crash zone sensor. 4. Replace the air bag diagnosis sensor unit. 5. Replace the related harness.

WHIA0200E

<Front RH seat belt pre-tensioner>	
Flash pattern	Repair order
<p>a through d are repeated. d: One flash indicates malfunctioning front RH seat belt pre-tensioner circuit.</p>	<ol style="list-style-type: none"> 1. Visually check the wiring harness connections. 2. Replace the harness if it has visible damage. 3. Replace front RH seat belt pre-tensioner. 4. Replace the air bag diagnosis sensor unit. 5. Replace the related harness.

WHIA0262E

<Front LH seat belt pre-tensioner>	
Flash pattern	Repair order
<p>a through d are repeated. d: Three flashes indicate malfunctioning front LH seat belt pre-tensioner circuit.</p>	<ol style="list-style-type: none"> 1. Visually check the wiring harness connections. 2. Replace the harness if it has visible damage. 3. Replace front LH seat belt pre-tensioner. 4. Replace the air bag diagnosis sensor unit. 5. Replace the related harness.

WHIA0263E

<RH side air bag (Satellite) sensor>	
Flash pattern	Repair order
<p>a through f are repeated. f: Three flashes indicate malfunctioning RH side air bag (Satellite) sensor circuit.</p>	<ol style="list-style-type: none"> 1. Visually check the wiring harness connection. 2. Replace the harness if it has visible damage. 3. Replace the RH side air bag (Satellite) sensor. 4. Replace the air bag diagnosis sensor unit. 5. Replace the related harness.

WHIA0203E

<LH side air bag (Satellite) sensor>	
Flash pattern	Repair order
<p>a through f are repeated. f: Four flashes indicate malfunctioning LH side air bag (Satellite) sensor.</p>	<ol style="list-style-type: none"> 1. Visually check the wiring harness connection. 2. Replace the harness if it has visible damage. 3. Replace the LH side air bag (Satellite) sensor. 4. Replace the air bag diagnosis sensor unit. 5. Replace the related harness.

WHIA0204E

TROUBLE DIAGNOSIS

< SYMPTOM DIAGNOSIS >

<Front RH side air bag module>	
Flash pattern a through f are repeated. f: One flash indicate malfunctioning front RH side air bag module circuit.	Repair order 1. Visually check the wiring harness connection. 2. Replace the harness if it has visible damage. 3. Replace the air bag diagnosis sensor unit. 4. Replace the front RH side air bag module. 5. Replace the related harness.
	AWHIA0305GB
<Front LH side air bag module>	
Flash pattern a through f are repeated. f: Two flashes indicate malfunctioning front LH side air bag module circuit.	Repair order 1. Visually check the wiring harness connection. 2. Replace the harness if it has visible damage. 3. Replace the air bag diagnosis sensor unit. 4. Replace the front LH side air bag module. 5. Replace the related harness.
	AWHIA0304GB
<RH side curtain air bag module>	
Flash pattern a through f are repeated. f: Five flashes indicate malfunctioning RH side curtain air bag module circuit.	Repair order 1. Visually check the wiring harness connection. 2. Replace the harness if it has visible damage. 3. Replace the air bag diagnosis sensor unit. 4. Replace RH side curtain air bag module. 5. Replace the related harness.
	AWHIA0308GB
<LH side curtain air bag module>	
Flash pattern a through f are repeated. f: Six flashes indicate malfunctioning LH side curtain air bag module circuit.	Repair order 1. Visually check the wiring harness connection. 2. Replace the harness if it has visible damage. 3. Replace the air bag diagnosis sensor unit. 4. Replace LH side curtain air bag module. 5. Replace the related harness.
	AWHIA0309GB
<Occupant classification system>	
Flash pattern a through d are repeated. d: Five flashes indicate malfunctioning occupant classification system control unit.	Repair order 1. Visually check the wiring harness connection. 2. Replace the harness if it has visible damage. 3. Replace the RH front seat cushion occupant classification system control unit assembly. 4. Replace the air bag diagnosis sensor unit.
	WHIA0211E

A

B

C

D

E

F

G

SRS

I

J

K

L

M

N

O

P

TROUBLE DIAGNOSIS

< SYMPTOM DIAGNOSIS >

Flash pattern	Repair order
<p><Front passenger air bag off indicator></p> <p>a through d are repeated. d: Eleven flashes indicate malfunctioning front passenger air bag off indicator.</p> <p>ON OFF</p> <p>7 sec. 2 sec. 3 sec. 2 sec. 2 sec. 0.5 sec. 3 sec. 2 sec.</p> <p>a b c d 11 flashes</p>	<ol style="list-style-type: none">1. Visually check the wiring harness connection.2. Replace the harness if it has visible damage.3. Replace front passenger air bag off indicator.4. Replace the air bag diagnosis sensor unit.5. Replace the related harness.

WHIA0212E

Trouble Diagnosis: "AIR BAG" Warning Lamp Does Not Turn Off

INFOID:000000007330554

DIAGNOSTIC PROCEDURE 7

1. CHECK CONDITION OF AIR BAG MODULE

Inspect for any deployed air bag modules or seat belt pre-tensioners.

Are any air bag modules or seat belt pre-tensioners deployed?

- Yes >> Refer to [SRS-49, "For Frontal Collision"](#) or [SRS-51, "For Side and Rollover Collision"](#).
- No >> GO TO 2.

2. CHECK THE AIR BAG FUSE

Check 10A fuse [No. 1, located in the fuse block (J/B)].

Refer to [SRS-11, "Schematic"](#).

OK or NG

- OK >> GO TO 4.
- NG >> GO TO 3.

3. CHECK AIR BAG FUSE AGAIN

Replace 10A fuse [No. 1, located in the fuse block (J/B)] and turn ignition switch ON.

Does the fuse blow again?

- Yes >> Repair harness.
- No >> Inspection End.

4. CHECK AIR BAG DIAGNOSIS SENSOR UNIT



Connect CONSULT and touch "START".

Is "AIR BAG" displayed on CONSULT?

- Yes >> GO TO 5.
- No >> Visually inspect the air bag diagnosis sensor unit harness connections. If the connections are OK, replace the air bag diagnosis sensor unit. Refer to [SRS-46, "Removal and Installation"](#).

5. CHECK HARNESS CONNECTION

Check for loose connections between the combination meter and the air bag diagnosis sensor unit.

OK or NG

- OK >> Replace air bag diagnosis sensor unit. Refer to [SRS-46, "Removal and Installation"](#).
- NG >> Properly connect the combination meter and air bag diagnosis sensor unit harness connectors. If "AIR BAG" warning lamp still does not turn off, replace the wiring harness.

Trouble Diagnosis: "AIR BAG" Warning Lamp Does Not Turn On

INFOID:000000007330555

DIAGNOSTIC PROCEDURE 8

1. CHECK METER FUSE

Check the 10A fuse [No. 3, located in the fuse block (J/B)].

Refer to [SRS-11, "Schematic"](#).

OK or NG

TROUBLE DIAGNOSIS

< SYMPTOM DIAGNOSIS >

OK >> GO TO 3.
NG >> GO TO 2.

A

2. REPLACE METER FUSE AND CHECK AGAIN

Replace 10A fuse [No. 3, located in the fuse block (J/B)] and turn ignition switch ON.

B

Does the fuse blow again?

Yes >> Replace harness.
No >> Inspection End.

C

3. CHECK HARNESS CONNECTIONS BETWEEN AIR BAG DIAGNOSIS SENSOR UNIT AND COMBINATION METER

Inspect the harness and connectors between the air bag diagnosis sensor unit and the combination meter.

D

Do the harness or connectors have any visible damage?

Yes >> Replace harness.
No >> GO TO 4.

E

4. CHECK COMBINATION METER

Disconnect the air bag diagnosis sensor unit harness connectors and turn ignition switch ON.

F

Does "AIR BAG" warning lamp turn on?

Yes >> Replace the air bag diagnosis sensor unit. Refer to [SRS-46. "Removal and Installation"](#).
No >> Replace the combination meter. Refer to [DI-19. "Removal and Installation"](#).

G

SRS

I

J

K

L

M

N

O

P

DRIVER AIR BAG MODULE

< ON-VEHICLE REPAIR >

ON-VEHICLE REPAIR

DRIVER AIR BAG MODULE

Removal and Installation

INFOID:000000007330556

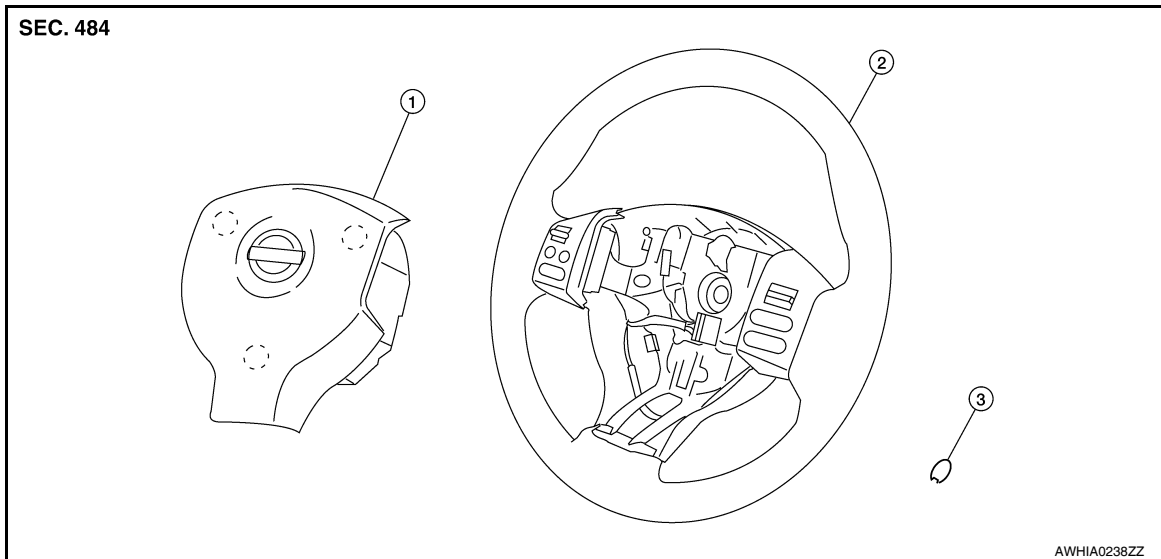

1. Driver air bag module

2. Steering wheel

3. Cover

○ Pawl

REMOVAL

WARNING:

- When servicing the SRS, do not work from directly in front of air bag module.
- Always place air bag module with pad side facing upward.

CAUTION:

- Before servicing the SRS, turn ignition switch OFF, disconnect both battery terminals, then wait at least three minutes.
- Do not attempt to repair or replace damaged direct-connect SRS component connectors. If a driver air bag direct-connect harness connector is damaged, the spiral cable must be replaced.
- Do not insert any foreign objects (screwdriver, etc.) into air bag module or harness connectors.
- Do not disassemble air bag module.
- Do not expose the air bag module to temperatures exceeding 90°C (194°F).

- Replace the air bag module if it has been dropped or sustained an impact.
- Do not allow oil, grease or water to come in contact with the air bag module.

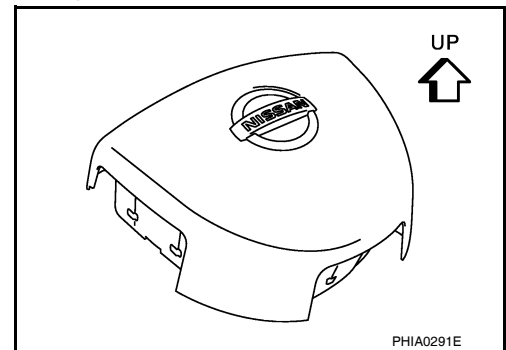

1. Place the steering wheel in the straight ahead position.
2. Disconnect the negative and positive battery terminals, then wait at least three minutes.
3. Remove the covers RH/LH.

DRIVER AIR BAG MODULE

< ON-VEHICLE REPAIR >

4. Release the driver air bag module retaining clips RH/LH.
 - Insert suitable 4mm - 6mm blunt tool (A) through LH access hole on back side of steering wheel (1) and contact retaining clip.

CAUTION:

Do not use sharp edged objects such as screwdrivers to release driver air bag module from steering wheel, SRS components may be unintentionally damaged.

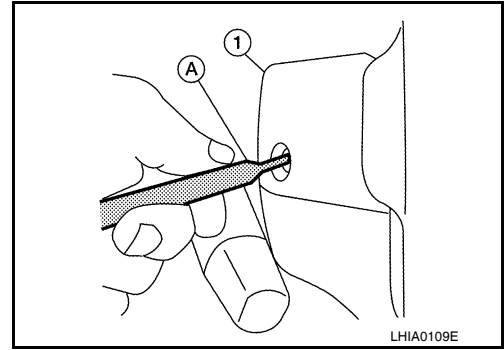

- Press tool inward with sufficient force on retaining clip (1) to release LH pawl of driver air bag module from steering wheel.
- Repeat for RH pawl of driver air bag module from steering wheel.
- Tilt top edge away from steering wheel, then lift upward releasing lower pawl of driver air bag module from steering wheel.

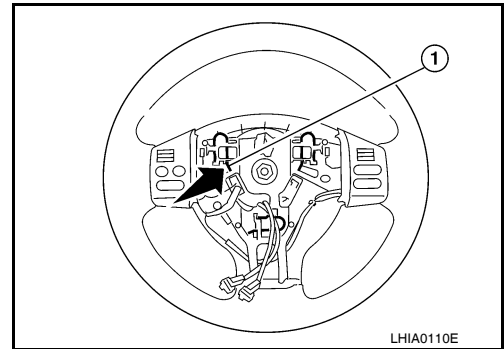

5. Disconnect driver air bag module connectors (1) and horn connector (2).

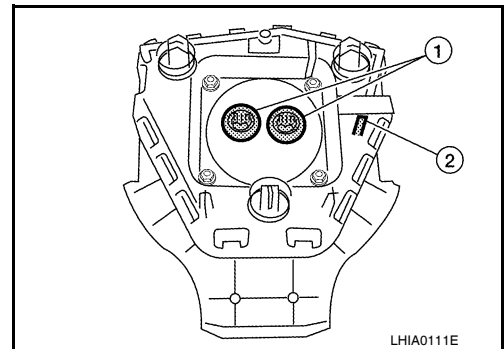

- For removal/installation of the direct-connect SRS connectors, refer to [SRS-7, "SRS Component Connectors"](#).

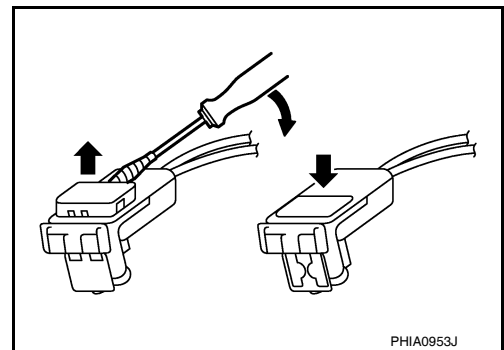

INSTALLATION

Installation is in the reverse order of removal.

CAUTION:

A
B
C
D
E
F
G
SRS
I
J
K
L
M
N
O
P

DRIVER AIR BAG MODULE

< ON-VEHICLE REPAIR >

- **Make sure driver air bag module harness (1) is routed properly to avoid SRS component damage during installation.**

NOTE:

- For removal/installation of the direct-connect SRS connectors, refer to [SRS-7, "SRS Component Connectors"](#).
- If driver air bag module is being replaced due to deployment, spiral cable must also be replaced. Refer to [SRS-37](#).
- After the work is completed, perform self-diagnosis to check that no malfunction is detected. Refer to [SRS-19, "SRS Operation Check"](#).

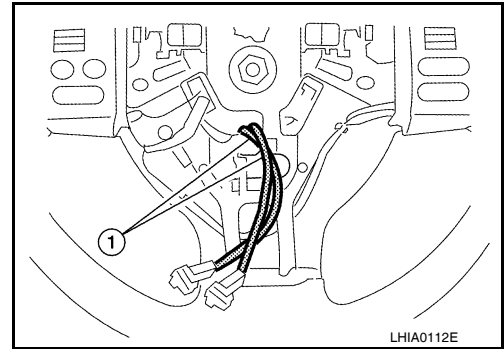

SPIRAL CABLE

< ON-VEHICLE REPAIR >

SPIRAL CABLE

Removal and Installation

INFOID:000000007330557

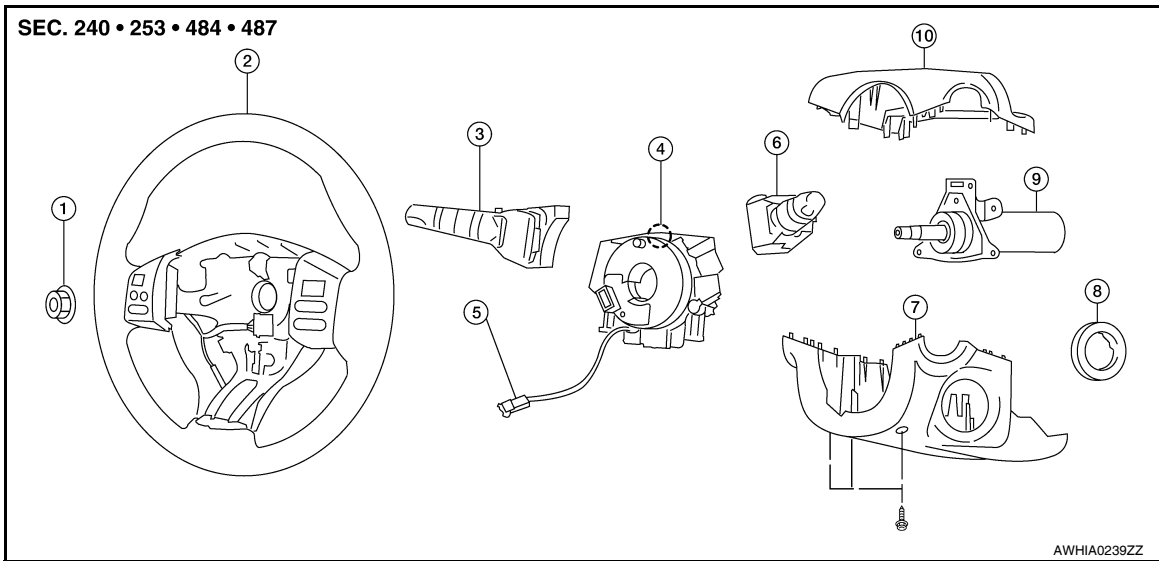

- | | | |
|---|-------------------------------------|------------------------------------|
| 1. Nut, refer to PS-7. "Removal and Installation" | 2. Steering wheel | 3. Lighting and turn signal switch |
| 4. Spiral cable | 5. Driver air bag module connectors | 6. Wiper and washer switch |
| 7. Column cover lower | 8. Steering lock escutcheon | 9. Steering column assembly |
| 10. Column cover upper | ○ Pawl | |

REMOVAL

WARNING:

When servicing the SRS, do not work from directly in front of air bag module.

CAUTION:

- Before servicing the SRS, turn ignition switch OFF, disconnect both battery terminals and wait at least three minutes.
- Do not tap or bump the steering wheel.
- Do not disassemble the spiral cable.
- Do not allow oil, grease or water to come in contact with the spiral cable.
- Replace the spiral cable if it has been dropped or sustained an impact.
- With the steering linkage disconnected, the spiral cable may snap by turning the steering wheel beyond the limited number of turns. The spiral cable can be turned counterclockwise about 2.5 turns from the neutral position.

1. Set the front wheels to the straight-ahead/neutral position.
2. Disconnect the negative and positive battery terminals, then wait at least three minutes.
3. Remove the steering wheel. Refer to [PS-7. "Removal and Installation"](#).
4. Remove the column cover upper and lower.
5. Disconnect wiper and washer switch connector (1). Then while pressing tabs (2), pull wiper and washer switch away from spiral cable to remove.

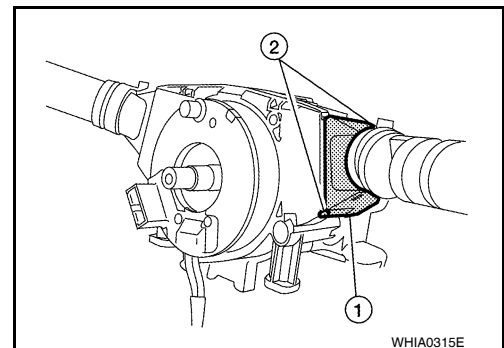

SPIRAL CABLE

< ON-VEHICLE REPAIR >

6. Disconnect lighting and turn signal switch connector (1). Then while pressing tabs (2), pull lighting and turn signal switch toward driver door to remove.
7. Remove the screws, then release the tab at the top and pull the spiral cable away from the steering column assembly.
8. Disconnect spiral cable connectors.

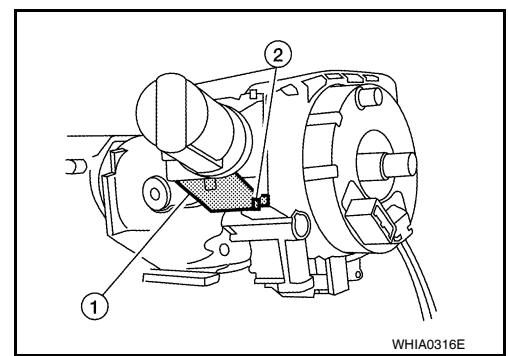

INSTALLATION

Installation is in the reverse order of removal.

NOTE:

- Align spiral cable correctly when installing steering wheel. Make sure spiral cable alignment and centering marks (B) are matched and in the neutral position. The neutral position is detected by turning left 2.5 revolutions from the right end position, ending with the locating pin (A) at the top. Place steering wheel in straight ahead position, then install it with the locating pin hole (C) directly over spiral cable locating pin.
- After the work is completed, perform self-diagnosis to make sure no malfunction is detected. Refer to [SRS-19. "SRS Operation Check"](#).

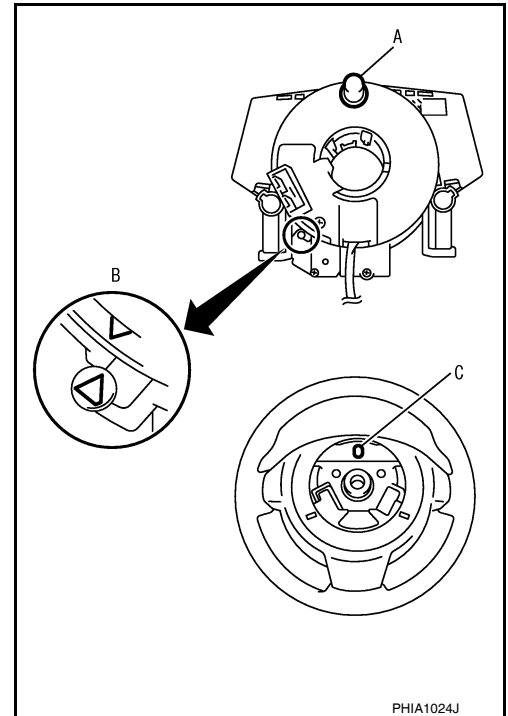

FRONT PASSENGER AIR BAG MODULE

< ON-VEHICLE REPAIR >

FRONT PASSENGER AIR BAG MODULE

Removal and Installation

INFOID:000000007330558

REMOVAL

WARNING:

- When servicing the SRS, do not work from directly in front of air bag module.
- Always place front passenger air bag module with pad side facing upward.

CAUTION:

- Before servicing SRS, turn the ignition switch OFF, disconnect both battery terminals and wait at least three minutes.
- Do not use old bolts after removal; replace with new bolts.
- Do not insert any foreign objects (screwdriver, etc.) into air bag module or harness connectors.
- Do not disassemble air bag module.
- Do not expose the front passenger air bag module to temperatures exceeding 90°C (194°F).
- Replace the front passenger air bag module if it has been dropped or sustained an impact.
- Do not allow oil, grease or water to come in contact with the front passenger air bag module.



1. Disconnect the negative and positive battery terminals, then wait at least three minutes.
2. Remove the side ventilator assembly (right). Refer to [IP-11](#).
3. Disconnect front passenger air bag module connector (1) and remove the upper instrument panel assembly bolts (2).
⇐: Vehicle front
4. Remove the front passenger air bag module bolts (3) from the steering member.

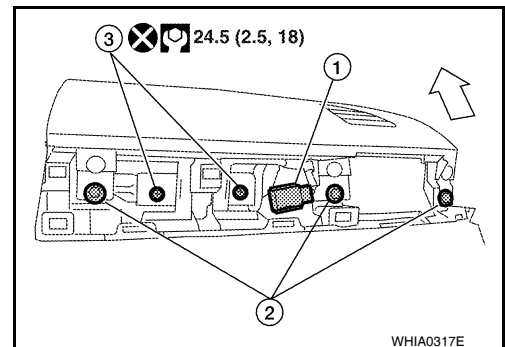

5. Release the pawls and remove the front passenger air bag module (1) from the upper instrument panel assembly (2).

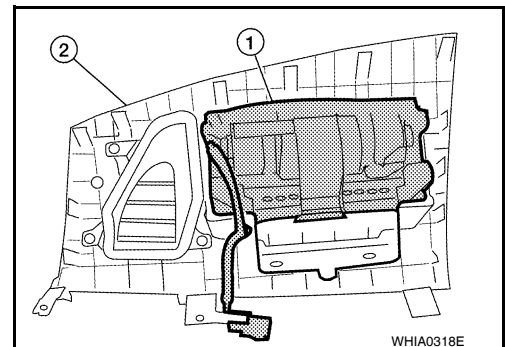

INSTALLATION

Installation is in the reverse order of removal.

NOTE:

- After the work is completed, perform self-diagnosis to check that no malfunction is detected. Refer to [SRS-19, "SRS Operation Check"](#).

SIDE CURTAIN AIR BAG MODULE

< ON-VEHICLE REPAIR >

SIDE CURTAIN AIR BAG MODULE

Component

INFOID:000000007330559

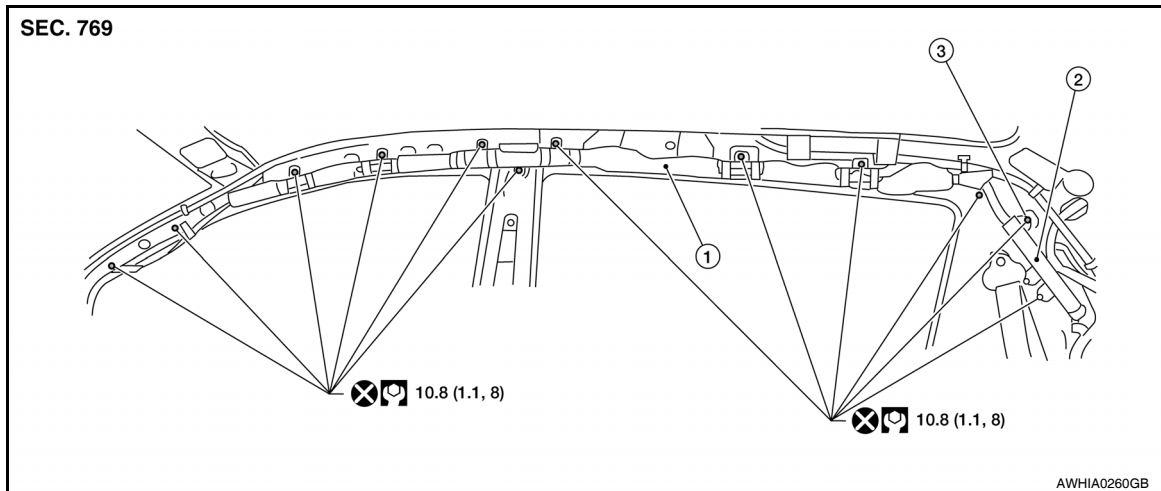

1. Side curtain air bag module

2. Inflator

3. Ground bolt

↶ Vehicle front

Removal and Installation

INFOID:000000007330560

REMOVAL

WARNING:

- When servicing the SRS, do not work from directly in front of air bag module.
- Always place the curtain air bag module with deployment side facing upward.
- Do not reuse center pillar upper garnish if removed.

CAUTION:

- Before servicing SRS, turn the ignition switch OFF, disconnect both battery terminals and wait at least three minutes.
- Do not use old bolts after removal; replace with new bolts.
- Do not insert any foreign objects (screwdriver, etc.) into air bag module or harness connectors.
- Do not disassemble air bag module.
- Do not expose the side curtain air bag module to temperatures exceeding 90°C (194°F).
- Replace the side curtain air bag module if it has been dropped or sustained an impact.
- Do not allow oil, grease or water to come in contact with the side curtain air bag module.
- Do not attempt to repair or replace damaged direct-connect SRS component connectors. If a direct-connect harness connector is damaged, the harness must be replaced.



1. Disconnect both the negative and positive battery terminals, then wait at least three minutes.
2. Remove the headlining. Refer to [EI-42, "Removal and Installation"](#).

SIDE CURTAIN AIR BAG MODULE

< ON-VEHICLE REPAIR >

3. Disconnect side curtain air bag module connector.

NOTE:

For removal/installation of the direct-connect SRS connectors, refer to [SRS-7, "SRS Component Connectors"](#).

4. Remove the bolts in order starting at the rear, then remove the side curtain air bag module.

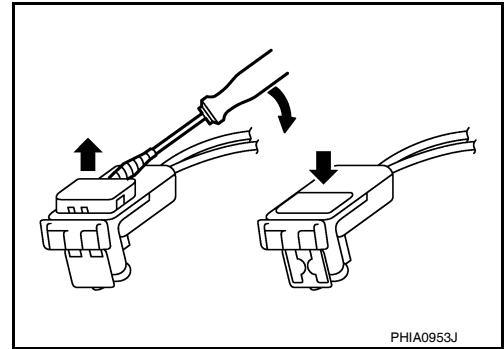

INSTALLATION

Installation is in the reverse order of removal.

NOTE:

- For removal/installation of the direct-connect SRS connectors, refer to [SRS-7, "SRS Component Connectors"](#).
- After replacement of side curtain air bag module, perform self-diagnosis to check that no malfunction is detected. Refer to [SRS-19, "SRS Operation Check"](#).

A
B
C
D
E
F
G
I
J
K
L
M
N
O
P

SRS

SIDE AIR BAG MODULE

< ON-VEHICLE REPAIR >

SIDE AIR BAG MODULE

Removal and Installation

INFOID:000000007795981

For side air bag module removal and installation, the front seatback must be disassembled, refer to [SE-14, "Disassembly and Assembly"](#).

NOTE:

If the vehicle has been involved in a collision and the side air bag has deployed, the front seatback assembly must be replaced.

CRASH ZONE SENSOR

< ON-VEHICLE REPAIR >

CRASH ZONE SENSOR

Removal and Installation

INFOID:000000007330561

REMOVAL

CAUTION:

- Before servicing the SRS, turn ignition switch OFF, disconnect both battery terminals and wait at least three minutes.
- Do not disassemble the crash zone sensor.
- Do not use old nuts after removal; replace with new nuts.
- Replace the crash zone sensor if it has been dropped or sustained an impact.
- Check crash zone sensor to make sure it is free of deformities, dents, cracks or rust. If it shows any visible signs of damage, replace it with a new one.



1. Disconnect both the negative and positive battery terminals, then wait at least three minutes.
2. Remove the air intake duct. Refer to [EM-16, "Component"](#).
3. Remove the upper radiator cover and front grille, refer to [EI-21, "Removal and Installation"](#).
4. Disconnect crash zone sensor harness connector (1).
5. Remove the nuts (2) and remove the crash zone sensor (3).

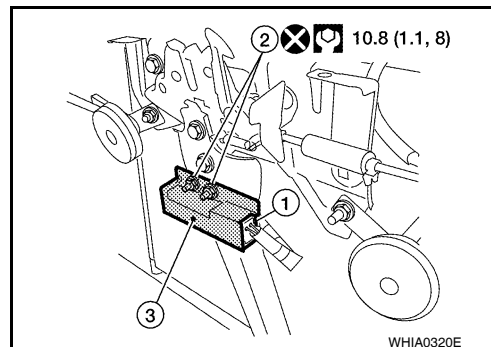

INSTALLATION

Installation is in the reverse order of removal.

NOTE:

- After the work is completed, perform self-diagnosis to check that no malfunction is detected. Refer to [SRS-19, "SRS Operation Check"](#).

SIDE AIR BAG (SATELLITE) SENSOR

< ON-VEHICLE REPAIR >

SIDE AIR BAG (SATELLITE) SENSOR

Removal and Installation

INFOID:000000007330562

REMOVAL

WARNING:

Do not reuse center pillar upper garnish if removed.

CAUTION:

- Before servicing the SRS, turn ignition switch OFF, disconnect both battery terminals and wait at least three minutes.
- Do not disassemble the side air bag (satellite) sensor.
- Do not use old nuts after removal; replace with new nuts.
- Replace the side air bag (satellite) sensor if it has been dropped or sustained an impact.
- Check side air bag (satellite) sensor to make sure it is free of deformities, dents, cracks or rust. If it shows any visible signs of damage, replace it with a new one.



1. Disconnect both the negative and positive battery terminals, then wait at least three minutes.
2. Remove the body side welt, kicking plate, and center pillar lower garnish. Refer to [EI-35. "Component"](#).
3. Remove the nuts (1) and remove side air bag (satellite) sensor (2).
⇐: Vehicle front
4. Disconnect the side air bag (satellite) sensor harness connector (3).

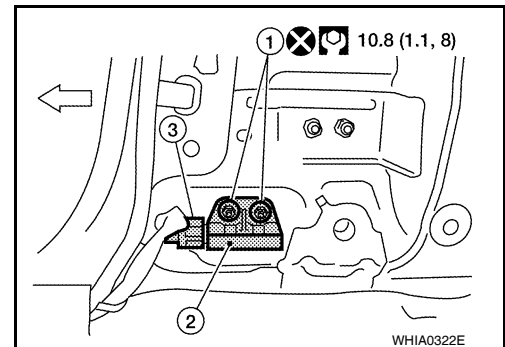

INSTALLATION

Installation is in the reverse order of removal.

NOTE:

- After the work is completed, perform self-diagnosis to make sure no malfunction is detected. Refer to [SRS-19. "SRS Operation Check"](#).

FRONT SEAT BELT PRE-TENSIONER

< ON-VEHICLE REPAIR >

FRONT SEAT BELT PRE-TENSIONER

Removal and Installation

INFOID:000000007330563

For removal and installation procedures, refer to [SB-4. "Removal and Installation of Front Seat Belt"](#).

- A
- B
- C
- D
- E
- F
- G
- SRS**
- I
- J
- K
- L
- M
- N
- O
- P

DIAGNOSIS SENSOR UNIT

< ON-VEHICLE REPAIR >

DIAGNOSIS SENSOR UNIT

Removal and Installation

INFOID:000000007330564

REMOVAL

WARNING:

Before disconnecting diagnosis sensor unit harness connector(s), be sure to disconnect harness connectors from air bag modules and front seat belt pre-tensioner to prevent deployment by static electricity.

CAUTION:

- Before servicing the SRS, turn the ignition switch OFF, disconnect both battery terminals and wait at least three minutes.
- Do not disassemble diagnosis sensor unit.
- Do not use old bolts; replace with new bolts.
- Replace the diagnosis sensor unit if it has been dropped or sustained an impact.
- Check diagnosis sensor unit bracket to make sure it is free of deformities, dents, cracks or rust. If it shows any visible signs of damage, replace with new one.
- The diagnosis sensor unit must always be installed with the arrow mark "←" pointing toward the front of the vehicle for proper operation.
- When replacing the air bag diagnosis sensor unit, always check with the parts department for the latest parts information. Installing an incorrect air bag diagnosis sensor unit may or may not cause the air bag warning lamp to illuminate and may cause incorrect deployment of the supplemental air bags and seat belt pre-tensioner in a collision resulting in serious personal injury or death.

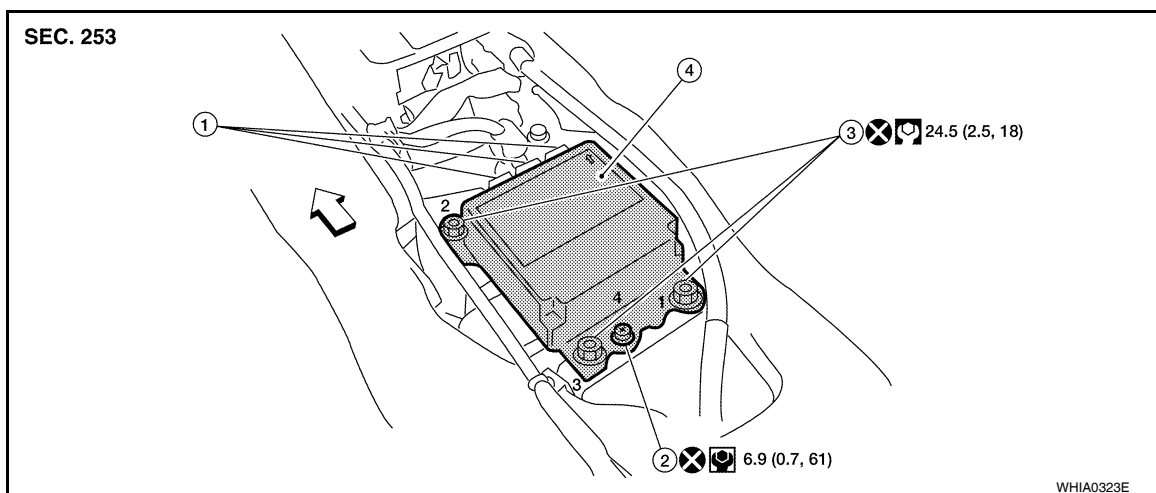

- | | | |
|-------------------------------------|-----------------|---------|
| 1. Diagnosis sensor unit connectors | 2. Ground Bolt | 3. Bolt |
| 4. Diagnosis sensor unit | ← Vehicle front | |

1. Always check the air bag diagnosis sensor unit ECU discriminated number (identification number) using CONSULT.
2. Disconnect the negative and positive battery terminals, then wait at least three minutes.
3. Disconnect the harness connectors for the following SRS components: Refer to [SRS-40](#) (Side Curtain Air Bag Module), [SRS-45](#) (Front Seat Belt Pre-tensioner), [SE-14. "Disassembly and Assembly"](#) (Side Air Bag Module).
4. Remove the rear seatback assembly. Refer to [SE-21. "Component Parts Drawing"](#).
5. Remove center console assembly. Refer to [IP-11](#).
6. Disconnect diagnosis sensor unit connectors.
7. Remove the bolts and the ground bolt, then remove the diagnosis sensor unit.

INSTALLATION

Installation is in the reverse order of removal.

- The diagnosis sensor unit must always be installed with the arrow mark "←" pointing toward the front of the vehicle.

DIAGNOSIS SENSOR UNIT

< ON-VEHICLE REPAIR >

- Follow the tightening sequence 1,2,3,4 as shown.
- After the work is completed, perform self-diagnosis to check that no malfunction is detected. Refer to [SRS-19. "SRS Operation Check"](#).

CAUTION:

- **After replacing the air bag diagnosis sensor unit, confirm using CONSULT that the ECU discriminated number (identification number) of the new replacement air bag diagnosis sensor unit matches the ECU discriminated number (identification number) of the replaced (old) air bag diagnosis sensor unit.**

NOTE:

- If the ECU discriminated number of the new replacement air bag diagnosis sensor unit differs from the ECU discriminated number of the replaced air bag diagnosis sensor unit, reconfirm the parts information and verify that the correct air bag diagnosis sensor unit was installed.

A
B
C
D
E
F
G
I
J
K
L
M
N
O
P

SRS

OCCUPANT CLASSIFICATION SYSTEM CONTROL UNIT

< ON-VEHICLE REPAIR >

OCCUPANT CLASSIFICATION SYSTEM CONTROL UNIT

Removal and Installation

INFOID:000000007330565

The occupant classification system control unit, occupant classification system sensor, and bladder are an integral part of the front passenger seat cushion and are replaced as an assembly. Refer to [SE-11](#) to remove the seat, and [SE-14, "Disassembly and Assembly"](#) to replace the seat cushion.

COLLISION DIAGNOSIS

< ON-VEHICLE REPAIR >

COLLISION DIAGNOSIS

For Frontal Collision

INFOID:000000007330566

FOR FRONTAL COLLISION: When SRS is activated in a collision

CAUTION:

Due to varying models and option levels, not all parts listed in the chart below apply to all vehicles.

WORK PROCEDURE

1. Before performing any of the following steps, ensure that all vehicle body and structural repairs have been completed.
2. Replace the diagnosis sensor unit.
3. Remove the front air bag modules, crash zone sensor assembly, bracket and seat belt pre-tensioner assemblies.
4. Check the SRS components using the table below:
Replace any SRS components showing visible signs of damage. (dents, cracks and deformation, etc.)
5. Install new front air bag modules, crash zone sensor assembly, bracket and seat belt pre-tensioner assemblies.
6. Perform self-diagnosis using CONSULT or air bag warning lamp. Refer to [SRS-18, "Self-Diagnosis Function \(Without CONSULT\)"](#) for details.
Ensure entire SRS operates properly.
7. After the work is completed, perform self-diagnosis to check that no malfunction is detected. Refer to [SRS-19, "SRS Operation Check"](#).

SRS INSPECTION (FOR FRONTAL COLLISION)

SRS

Part	Inspection
Driver air bag module	If the driver air bag has deployed: REPLACE Install with new fasteners.
Front passenger air bag module (if equipped)	If the front passenger air bag has deployed: REPLACE Install with new fasteners.
Crash zone sensor	If any of the front air bags or seat belt pre-tensioners* have been activated: REPLACE the crash zone sensor and bracket with new fasteners. *: Confirm seat belt pre-tensioner activation using CONSULT only.
Seat belt pre-tensioner assemblies (All applicable locations: buckle, retractor, lap outer)	If either the driver or passenger seat belt pre-tensioner* has been activated: REPLACE all seat belt pre-tensioner assemblies with new fasteners. *: Confirm seat belt pre-tensioner activation using CONSULT only.
Diagnosis sensor unit	If any of the SRS components have been activated: REPLACE the diagnosis sensor unit. Install with new fasteners.
Steering wheel	<ol style="list-style-type: none"> 1. Visually check steering wheel for deformities. 2. Check harness (built into steering wheel) and connectors for damage, and terminals for deformities. 3. Install driver air bag module into the steering wheel to check fit and alignment with the wheel. 4. Check steering wheel for excessive free play. 5. If no damage is found, reinstall. 6. If damaged—REPLACE.
Spiral cable	If the driver front air bag has deployed: REPLACE the spiral cable.
Occupant classification system (Passenger seat)	<ol style="list-style-type: none"> 1. Remove passenger seat assembly. 2. Check control unit case for dents, cracks or deformities. 3. Check connectors and pressure sensor tube for damage, and terminals for deformities. 4. Check seat frame and cushion pan for dents or deformities. 5. If no damage is found, reinstall seat with new fasteners. 6. If damaged — REPLACE seat cushion assembly with new fasteners.

COLLISION DIAGNOSIS

< ON-VEHICLE REPAIR >

Part	Inspection
Harness and connectors	<ol style="list-style-type: none"> 1. Check connectors for poor connection, damage, and terminals for deformities. 2. Check harness for binding, chafing, cuts, or deformities. 3. If no damage is found, reinstall the harness and connectors. 4. If damaged—REPLACE the damaged harness. Do not attempt to repair, splice or modify any SRS harness.
Instrument panel assembly	If the passenger front air bag has deployed: REPLACE the instrument panel assembly. (integrated type)

FOR FRONTAL COLLISION: When SRS is not activated in a collision

CAUTION:

Due to varying models and option levels, not all parts listed in the chart below apply to all vehicles.

WORK PROCEDURE

1. Before performing any of the following steps, ensure that all vehicle body and structural repairs have been completed.
2. Check the SRS components using the table below:
Replace any SRS components showing visible signs of damage. (dents, cracks and deformation, etc.)
3. Perform self-diagnosis using CONSULT or air bag warning lamp. Refer to [SRS-18, "Self-Diagnosis Function \(Without CONSULT\)"](#) for details.
Ensure entire SRS operates properly.
4. After the work is completed, perform self-diagnosis to check that no malfunction is detected. Refer to [SRS-19, "SRS Operation Check"](#).

SRS INSPECTION (FOR FRONTAL COLLISION)

Part	Inspection
Driver air bag module	<p>If the driver air bag has NOT been activated:</p> <ol style="list-style-type: none"> 1. Remove driver air bag module. Check harness cover and connectors for damage, terminals for deformities, and harness for binding. 2. Install driver air bag module into the steering wheel to check fit and alignment with the wheel. 3. If no damage is found, reinstall with new fasteners. 4. If damaged—REPLACE. Install driver air bag modules with new fasteners.
Front passenger air bag module (if equipped)	<p>If the front passenger air bag has NOT been activated:</p> <ol style="list-style-type: none"> 1. Remove front passenger air bag module. Check harness cover and connectors for damage, terminals for deformities, and harness for binding. 2. Install front passenger air bag module into the instrument panel to check fit with the instrument panel. 3. If no damage is found, reinstall with new fasteners. 4. If damaged—REPLACE. Install front passenger air bag modules with new fasteners.
Crash zone sensor	<p>If the front air bags or seat belt pre-tensioners have NOT been activated:</p> <ol style="list-style-type: none"> 1. Remove the crash zone sensor. Check harness connectors for damage, terminals for deformities, and harness for binding. 2. Check for visible signs of damage (dents, cracks, deformation) of the crash zone sensor and bracket. 3. Install the crash zone sensor to check fit. 4. If no damage is found, reinstall with new fasteners. 5. If damaged—REPLACE the crash zone sensor and bracket with new fasteners.
Seat belt pre-tensioner assemblies (All applicable locations: buckle, retractor, lap outer)	<p>If the pre-tensioners have NOT been activated:</p> <ol style="list-style-type: none"> 1. Remove seat belt pre-tensioners. Check harness cover and connectors for damage, terminals for deformities, and harness for binding. 2. Check belts for damage and anchors for loose mounting. 3. Check retractor for smooth operation. 4. Check seat belt adjuster for damage. 5. Check for deformities of the center pillar inner. 6. If the center pillar inner has no damage, REPLACE the seat belt pre-tensioner assembly. 7. If no damage is found, reinstall seat belt pre-tensioner assembly. 8. If damaged—REPLACE. Install the seat belt pre-tensioners with new fasteners.

COLLISION DIAGNOSIS

< ON-VEHICLE REPAIR >

Part	Inspection
Diagnosis sensor unit	If none of the SRS components have been activated: <ol style="list-style-type: none"> 1. Check case for dents, cracks or deformities. 2. Check connectors for damage, and terminals for deformities. 3. If no damage is found, reinstall with new fasteners. 4. If damaged—REPLACE. Install diagnosis sensor unit with new fasteners.
Steering wheel	<ol style="list-style-type: none"> 1. Visually check steering wheel for deformities. 2. Check harness (built into steering wheel) and connectors for damage, and terminals for deformities. 3. Install driver air bag module into the steering wheel to check fit and alignment with the wheel. 4. Check steering wheel for excessive free play. 5. If no damage is found, reinstall. 6. If damaged—REPLACE.
Spiral cable	If the driver front air bag has not deployed: <ol style="list-style-type: none"> 1. Visually check spiral cable and combination switch for damage. 2. Check connectors and protective tape for damage. 3. Check steering wheel for noise, binding or heavy operation. 4. If no damage is found, reinstall. 5. If damaged—REPLACE.
Occupant classification system (Passenger seat)	<ol style="list-style-type: none"> 1. Remove passenger seat assembly. 2. Check control unit case for dents, cracks or deformities. 3. Check connectors and pressure sensor tube for damage, and terminals for deformities. 4. Check seat frame and cushion pan for dents or deformities. 5. If no damage is found, reinstall seat with new fasteners. 6. If damaged — REPLACE seat cushion assembly with new fasteners.
Harness and connectors	<ol style="list-style-type: none"> 1. Check connectors for poor connection, damage, and terminals for deformities. 2. Check harness for binding, chafing, cuts, or deformities. 3. If no damage is found, reinstall the harness and connectors. 4. If damaged—REPLACE the damaged harness. Do not attempt to repair, splice or modify any SRS harness.
Instrument panel assembly	If the passenger front air bag has NOT deployed: <ol style="list-style-type: none"> 1. Visually check instrument panel for damage. 2. If no damage is found, reinstall the instrument panel assembly. 3. If damaged—REPLACE the instrument panel assembly.

A
B
C
D
E
F
G
SRS
I
J
K
L
M
N
O
P

For Side and Rollover Collision

INFOID:000000007330567

FOR SIDE AND ROLLOVER COLLISION: When SRS is activated in a collision

CAUTION:

Due to varying models and option levels, not all parts listed in the chart below apply to all vehicles.

WORK PROCEDURE

1. Before performing any of the following steps, ensure that all vehicle body and structural repairs have been completed.
2. Replace the following components:
 - Front seat back assembly (on the side on which side air bag is activated).
 - Door finisher (on the side on which door-mounted curtain air bag is activated).
 - Pop-up roll bar assemblies and pop-up roll bar covers.
 - Side air bag (satellite) sensor LH/RH (on the side on which side air bag is activated).
 - Diagnosis sensor unit.
 - Seat belt pre-tensioner assemblies.
3. Check the SRS components and the related parts using the following table. Replace any SRS components and the related parts showing visible signs of damage (dents, cracks, deformation, etc.).
4. Perform self-diagnosis using CONSULT and "AIR BAG" warning lamp. Refer to [SRS-19, "SRS Operation Check"](#) for details. Make sure entire SRS operates properly.
5. After the work is completed, perform self-diagnosis to check that no malfunction is detected. Refer to [SRS-18, "Self-Diagnosis Function \(Without CONSULT\)"](#).

SRS INSPECTION (FOR SIDE AND ROLLOVER COLLISION)

COLLISION DIAGNOSIS

< ON-VEHICLE REPAIR >

Part	Inspection
Side curtain air bag module LH	If the side curtain air bag LH has deployed: REPLACE the side curtain air bag module LH. Install with new fasteners.
Side curtain air bag module RH	If the side curtain air bag RH has deployed: REPLACE the side curtain air bag module RH. Install with new fasteners.
Front side air bag module LH	If the front side air bag LH has deployed: REPLACE front seatback assembly LH.
Front side air bag module RH	If the front side air bag RH has deployed: REPLACE front seatback assembly RH.
Side air bag (satellite) sensor (LH or RH)	If any of the SRS components have deployed: REPLACE the side air bag (satellite) sensor on the collision side with new fasteners.
Diagnosis sensor unit	If any of the SRS components have deployed: REPLACE the diagnosis sensor unit with new fasteners.
Seat belt pre-tensioner assemblies (All applicable locations: buckle, retractor, lap outer)	If either the driver or passenger seat belt pre-tensioner* has been activated: REPLACE all seat belt pre-tensioner assemblies with new fasteners. *: Confirm seat belt pre-tensioner activation using CONSULT only.
Center inner pillar	1. Check the center inner pillar on the collision side for damage (dents, cracks, deformation). 2. If damaged—REPAIR the center inner pillar.
Seat (if equipped with front side air bag)	If either the front LH or front RH side air bag modules has been deployed: REPLACE front seatback assembly on the deployed side.
Trim/headlining	1. Check for visible signs of damage (dents, cracks, deformation) of the interior trim on the collision side. 2. If damaged—REPLACE the damaged trim parts.
Door-mounted curtain air bag module LH	If the door-mounted curtain air bag module LH has been deployed: REPLACE the door finisher LH and door-mounted curtain air bag module. Install with new fasteners.
Door-mounted curtain air bag module RH	If the door-mounted curtain air bag module RH has been deployed: REPLACE the door finisher RH and door-mounted curtain air bag module. Install with new fasteners.
Pop-up roll bar assemblies	If the pop-up roll bar has deployed: REPLACE pop-up roll bar assemblies and pop-up roll bar covers. Install with new fasteners.

FOR SIDE AND ROLLOVER COLLISION: When SRS is not activated in a collision

CAUTION:

Due to varying models and option levels, not all parts listed in the chart below apply to all vehicles.

WORK PROCEDURE

1. Before performing any of the following steps, ensure that all vehicle body and structural repairs have been completed.
2. Check the SRS components and the related parts using the following table.
 - If the front seat back assembly is damaged, the front seat back assembly must be replaced.
 - If the door finisher assembly is damaged, the door finisher assembly and door-mounted curtain air bag module must be replaced.
3. Perform self-diagnosis using CONSULT and "AIR BAG" warning lamp. Refer to [SRS-19, "SRS Operation Check"](#) for details. Make sure entire SRS operates properly.
4. After the work is completed, perform self-diagnosis to check that no malfunction is detected. Refer to [SRS-18, "Self-Diagnosis Function \(Without CONSULT\)"](#).

SRS INSPECTION (FOR SIDE AND ROLLOVER COLLISION)

COLLISION DIAGNOSIS

< ON-VEHICLE REPAIR >

Part	Inspection
Side curtain air bag module LH	If the side curtain air bag LH has NOT deployed: <ol style="list-style-type: none"> 1. Check for visible signs of damage (dents, tears, deformation) of the center pillar on the collision side. 2. If damaged—Remove the side curtain air bag module LH. 3. Check for visible signs of damaged (tears etc.) of the side curtain air bag module LH. 4. Check harness and connectors for damage, and terminals for deformities. 5. If no damage is found, reinstall the side curtain air bag module LH with new fasteners. 6. If damaged—REPLACE the side curtain air bag module LH with new fasteners.
Side curtain air bag module RH	If the side curtain air bag RH has NOT deployed: <ol style="list-style-type: none"> 1. Check for visible signs of damage (dents, tears, deformation) of the center pillar on the collision side. 2. If damaged—Remove the side curtain air bag module RH. 3. Check for visible signs of damaged (tears etc.) of the side curtain air bag module RH. 4. Check harness and connectors for damage, and terminals for deformities. 5. If no damage is found, reinstall the side curtain air bag module RH with new fasteners. 6. If damaged—REPLACE the side curtain air bag module RH with new fasteners.
Front side air bag module LH	If the front LH side air bag has NOT deployed: <ol style="list-style-type: none"> 1. Check for visible signs of damage (dents, tears, deformation) of the seat back on the collision side. 2. Check harness and connectors for damage, and terminals for deformities. 3. If damaged—REPLACE the front seatback assembly LH.
Front side air bag module RH	If the front side air bag RH has NOT deployed: <ol style="list-style-type: none"> 1. Check for visible signs of damage (dents, tears, deformation) of the seat back on the collision side. 2. Check harness and connectors for damage, and terminals for deformities. 3. If damaged—REPLACE the front seatback assembly RH.
Side air bag (satellite) sensor (LH or RH)	If none of the SRS components have been activated: <ol style="list-style-type: none"> 1. Remove the side air bag (satellite) sensor (LH or RH) on the collision side. Check harness connectors for damage, terminals for deformities, and harness for binding. 2. Check for visible signs of damage (dents, cracks, deformation) of the side air bag (satellite) sensor (LH or RH). 3. Install the side air bag (satellite) sensor (LH or RH) to check fit. 4. If no damage is found, reinstall the side sir bag (satellite) sensor (LH or RH) with new fasteners. 5. If damaged—REPLACE the side air bag (satellite) sensor (LH or RH) with new fasteners.
Diagnosis sensor unit	If none of the SRS components have been activated: <ol style="list-style-type: none"> 1. Check case and bracket for dents, cracks or deformities. 2. Check connectors for damage, and terminals for deformities. 3. If no damage is found, reinstall the diagnosis sensor unit with new fasteners. 4. If damaged—REPLACE the diagnosis sensor unit with new fasteners.
Seat belt pre-tensioner assemblies (All applicable locations: buckle, retractor, lap outer)	If the pre-tensioners have NOT been activated: <ol style="list-style-type: none"> 1. Remove seat belt pre-tensioners. Check harness cover and connectors for damage, terminals for deformities, and harness for binding. 2. Check belts for damage and anchors for loose mounting. 3. Check retractor for smooth operation. 4. Check seat belt adjuster for damage. 5. Check for deformities of the center pillar inner. 6. If the center pillar inner has no damage, REPLACE the seat belt pre-tensioner assembly. 7. If no damage is found, reinstall seat belt pre-tensioner assembly. 8. If damaged—REPLACE. Install the seat belt pre-tensioners with new fasteners.
Seat (with front side air bag)	If the front LH or front RH side air bag modules have NOT deployed: <ol style="list-style-type: none"> 1. Visually check the seat on the collision side. 2. Remove the seat on the collision side and check the following for damage and deformities. <ul style="list-style-type: none"> - Harness, connectors and terminals - Frame and recliner (for front and rear seat), and also adjuster and slides (for front seat) 3. If no damage is found, reinstall the seat. 4. If damaged—REPLACE the damaged seat parts using new fasteners. If the front seat back is damaged, the front seat back assembly must be replaced.

A

B

C

D

E

F

G

SRS

I

J

K

L

M

N

O

P

COLLISION DIAGNOSIS

< ON-VEHICLE REPAIR >

Part	Inspection
Center inner pillar	<ol style="list-style-type: none"> 1. Check the center inner pillar on the collision side for damage (dents, cracks, deformation, etc.). 2. If damaged - REPAIR the center inner pillar.
Trim/headlining	<ol style="list-style-type: none"> 1. Check for visible signs of damage (dents, cracks, deformation, etc.) of the interior trim on the collision side. 2. If damaged - REPLACE the damaged trim parts.
Door-mounted curtain air bag module LH	<p>If the door-mounted curtain air bag LH has NOT deployed:</p> <ol style="list-style-type: none"> 1. Check for visible signs of damage (dents tears, deformation, etc.) of the door finisher on the collision side. 2. If damaged - REPLACE the door finisher LH with new fasteners. 3. Check for visible signs of damaged (dents etc.) of the door-mounted curtain air bag module LH. 4. Check harness and connectors for damage, and terminals for deformities. 5. If no damage is found, reinstall door finisher. <p>CAUTION: When removing door mounted curtain air bag module from door finisher, never reuse door finisher.</p> <ol style="list-style-type: none"> 6. If damaged - REPLACE the door finisher LH and door-mounted curtain air bag module LH with new fasteners.
Door-mounted curtain air bag module RH	<p>If the door-mounted curtain air bag RH has NOT deployed:</p> <ol style="list-style-type: none"> 1. Check for visible signs of damage (dents tears, deformation, etc.) of the door finisher on the collision side. 2. If damaged - REPLACE the door finisher RH with new fasteners. 3. Check for visible signs of damaged (tears etc.) of the door-mounted curtain air bag module RH. 4. Check harness and connectors for damage, and terminals for deformities. 5. If no damage is found, reinstall door finisher. <p>CAUTION: When removing door mounted curtain air bag module from door finisher, never reuse door finisher.</p> <ol style="list-style-type: none"> 6. If damaged - REPLACE the door finisher RH and door-mounted curtain air bag module RH with new fasteners.
Pop-up roll bar	<p>If the pop-up roll bar NOT deployed:</p> <ol style="list-style-type: none"> 1. Check for visible signs of damage (dents tears, deformation, etc.) of the pop-up roll bar. 2. If damaged - REPLACE the pop-up roll bar with new fasteners. 3. Check harness and connectors for damage, and terminals for deformities. 4. If no damage is found, reinstall the pop-up roll bar with new fasteners. 5. Check for visible signs of damage (dents, cracks, deformation, etc.) of the seatback support brace assembly. 6. If damaged - REPAIR the seatback support brace assembly.