

ENGINE LUBRICATION SYSTEM

CONTENTS

	<b>HR16DE</b>				
<b>PRECAUTION</b>	.....	2			
<b>PRECAUTIONS</b>	.....	2			
Precaution for Supplemental Restraint System (SRS) "AIR BAG" and "SEAT BELT PRE-TENSIONER"	.....	2			
Liquid Gasket	.....	2			
<b>PREPARATION</b>	.....	4			
<b>PREPARATION</b>	.....	4			
Special Service Tool	.....	4			
Commercial Service Tools	.....	4			
<b>SYSTEM DESCRIPTION</b>	.....	5			
<b>DESCRIPTION</b>	.....	5			
Engine Lubrication System	.....	5			
Engine Lubrication System Schematic	.....	6			
<b>PERIODIC MAINTENANCE</b>	.....	7			
<b>ENGINE OIL</b>	.....	7			
	Inspection	.....	7		
	Draining	.....	8		
	Refilling	.....	8		
	<b>OIL FILTER</b>	.....	10		
	Removal and Installation	.....	10		
	<b>REMOVAL AND INSTALLATION</b>	.....	11		
	<b>OIL PUMP</b>	.....	11		
	Exploded View	.....	11		
	Removal and Installation	.....	11		
	<b>OIL COOLER</b>	.....	13		
	Exploded View	.....	13		
	Removal and Installation	.....	13		
	<b>SERVICE DATA AND SPECIFICATIONS (SDS)</b>	.....	15		
	<b>SERVICE DATA AND SPECIFICATIONS (SDS)</b>	.....	15		
	Periodical Maintenance Specification	.....	15		
	Engine Oil Pressure	.....	15		

## PRECAUTION

### PRECAUTIONS

#### Precaution for Supplemental Restraint System (SRS) "AIR BAG" and "SEAT BELT PRE-TENSIONER"

INFOID:000000009549393

The Supplemental Restraint System such as "AIR BAG" and "SEAT BELT PRE-TENSIONER", used along with a front seat belt, helps to reduce the risk or severity of injury to the driver and front passenger for certain types of collision. Information necessary to service the system safely is included in the SR and SB section of this Service Manual.

**WARNING:**

- To avoid rendering the SRS inoperative, which could increase the risk of personal injury or death in the event of a collision which would result in air bag inflation, all maintenance must be performed by an authorized NISSAN/INFINITI dealer.
- Improper maintenance, including incorrect removal and installation of the SRS, can lead to personal injury caused by unintentional activation of the system. For removal of Spiral Cable and Air Bag Module, see the SR section.
- Do not use electrical test equipment on any circuit related to the SRS unless instructed to in this Service Manual. SRS wiring harnesses can be identified by yellow and/or orange harnesses or harness connectors.

#### PRECAUTIONS WHEN USING POWER TOOLS (AIR OR ELECTRIC) AND HAMMERS

**WARNING:**

- When working near the Airbag Diagnosis Sensor Unit or other Airbag System sensors with the Ignition ON or engine running, DO NOT use air or electric power tools or strike near the sensor(s) with a hammer. Heavy vibration could activate the sensor(s) and deploy the air bag(s), possibly causing serious injury.
- When using air or electric power tools or hammers, always switch the Ignition OFF, disconnect the battery and wait at least three minutes before performing any service.

#### Liquid Gasket

INFOID:000000009549394

##### REMOVAL OF LIQUID GASKET SEALING

- After removing the bolts and nuts, separate the mating surface and remove the liquid gasket using Tool (A).

Tool Number : KV10111100 (J-37228)

**CAUTION:**

**Be careful not to damage the mating surfaces.**

- In areas where the cutter is difficult to use, use a plastic hammer to lightly tap (1) the cutter where the liquid gasket is applied. Use a plastic hammer to slide (2) the cutter by tapping on the side.

**CAUTION:**

**Do not damage the mating surfaces.**

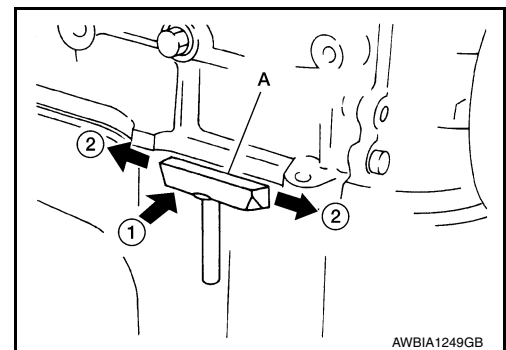

##### LIQUID GASKET APPLICATION PROCEDURE

1. Using suitable tool (A), remove old liquid gasket adhering to the liquid gasket application surface and the mating surface.
  - Remove liquid gasket completely from the groove of the liquid gasket application surface, mounting bolts, and bolt holes.
2. Wipe the liquid gasket application surface and the mating surface with white gasoline (lighting and heating use) to remove adhering moisture, grease and foreign materials.

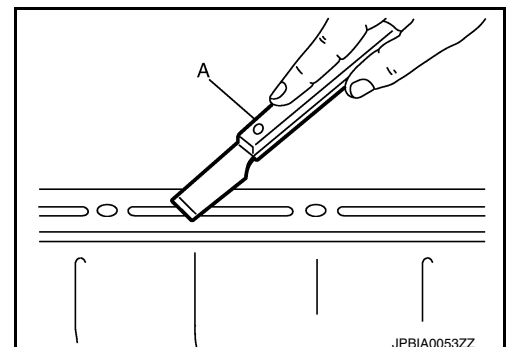

# PRECAUTIONS

[HR16DE]

## < PRECAUTION >

3. Attach liquid gasket tube to the suitable tool.  
**Use Genuine Silicone RTV Sealant, or equivalent. Refer to [GI-22, "Recommended Chemical Products and Sealants"](#).**
4. Apply liquid gasket without gaps to the specified location according to the specified dimensions.
  - If there is a groove for liquid gasket application, apply liquid gasket to the groove.

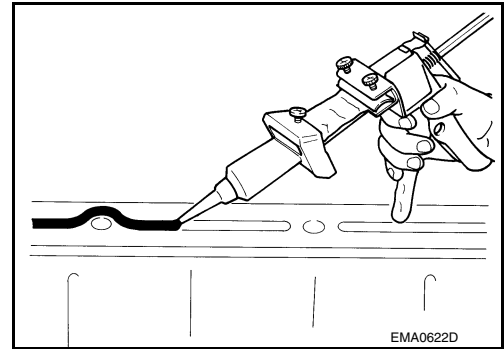

- As for bolt holes (B), normally apply liquid gasket inside the holes. Occasionally, it should be applied outside the holes. Check to read the text of this manual.

(A) : Groove

⇐ : Inside

- Within five minutes of liquid gasket application, install the mating component.
- If liquid gasket protrudes, wipe it off immediately.
- Do not retighten mounting bolts or nuts after the installation.
- After 30 minutes or more have passed from the installation, fill engine oil and engine coolant.

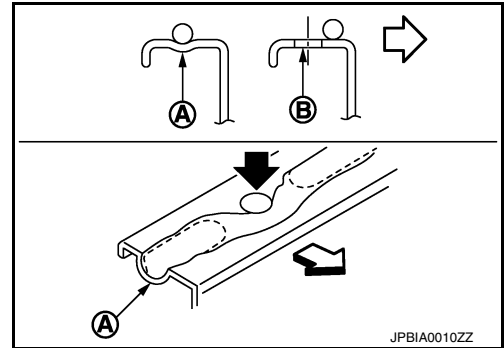

### CAUTION:

**If there are specific instructions in the procedures contained in this manual concerning liquid gasket application, observe them.**

# PREPARATION

< PREPARATION >

[HR16DE]

## PREPARATION

### PREPARATION

#### Special Service Tool

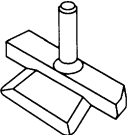

INFOID:000000009643046

The actual shapes of Kent-Moore tools may differ from those of special service tools illustrated here.

Tool number (Kent-Moore No.) Tool name	Description
KV10111100 (J-37228) Seat cutter	Removing oil pan (lower) etc.
 <p style="text-align: center;">NT046</p>	

#### Commercial Service Tools

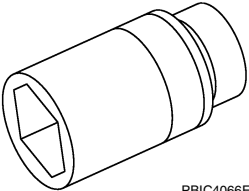
INFOID:000000009444771

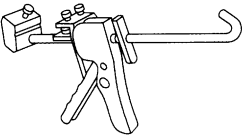
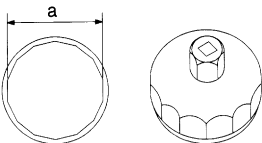
Tool name	Description
Deep socket	Removing and installing oil pressure sensor <b>27 mm (1.06 in)</b>
 <p style="text-align: center;">PBIC4066E</p>	
Power tool	Loosening nuts, screws and bolts
 <p style="text-align: center;">PIB1407E</p>	
Tube presser	Pressing the tube of liquid gasket
 <p style="text-align: center;">NT052</p>	
KV10115801 (J-38956) Oil filter wrench	Removing oil filter <b>64.3 mm (2.531 in)</b>
 <p style="text-align: center;">S-NT375</p>	

**SYSTEM DESCRIPTION**

## DESCRIPTION

## Engine Lubrication System

INFOID:000000009444772

A

LU

C

D

E

F

G

H

I

J

K

L

M

N

O

P

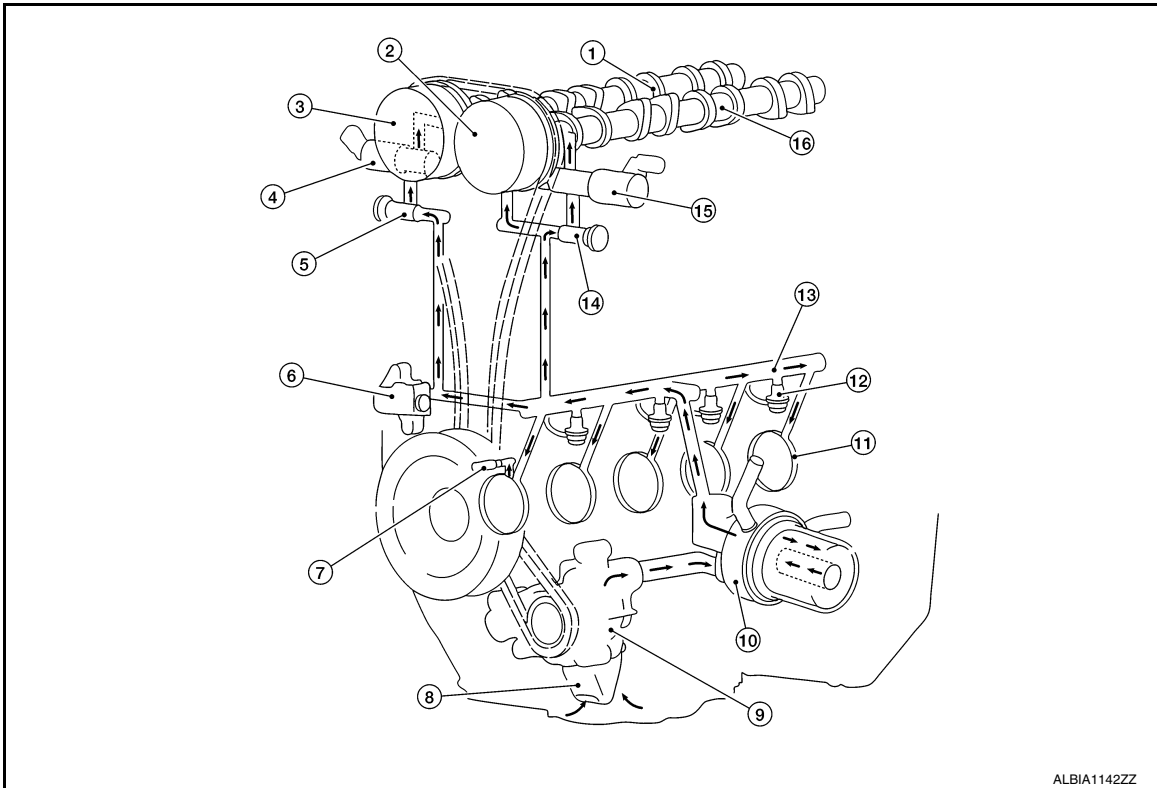

- |  |  |  |
|--|--|--|
| 1. Exhaust camshaft                            | 2. Intake valve timing controller          | 3. Exhaust valve timing controller             |
| 4. Exhaust valve timing control solenoid valve | 5. Exhaust timing control oil filter       | 6. Chain tensioner                             |
| 7. Chain oil jet                               | 8. Oil strainer                            | 9. Oil pump                                    |
| 10. Oil cooler                                 | 11. Oil filter                             | 12. Main bearing                               |
| 13. Piston oil jet                             | 14. Intake valve timing control oil filter | 15. Intake valve timing control solenoid valve |
| 16. Intake camshaft                            |  |  |

# DESCRIPTION

< SYSTEM DESCRIPTION >

[HR16DE]

## Engine Lubrication System Schematic

INFOID:00000009444773

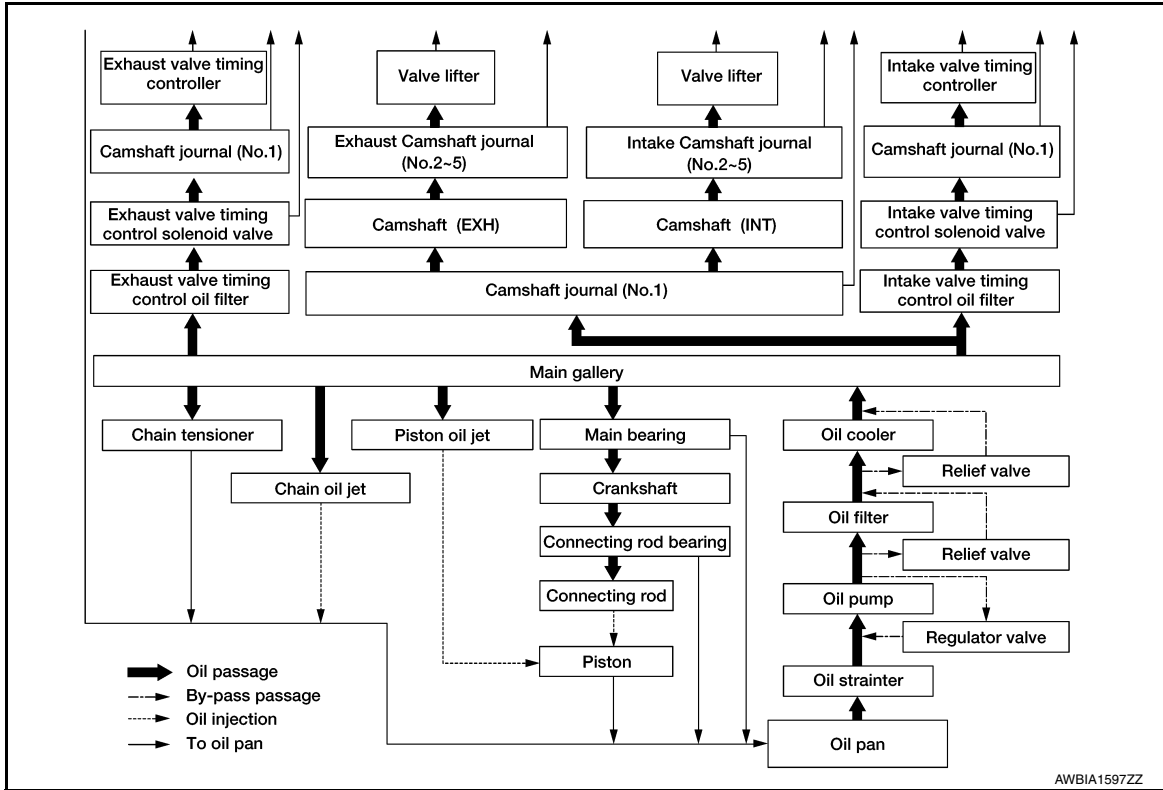

## PERIODIC MAINTENANCE

### ENGINE OIL

#### Inspection

INFOID:000000009444774

LU

#### ENGINE OIL LEVEL

##### NOTE:

Before starting engine, position the vehicle so that it is level and check the engine oil level. If engine is already started, stop it and allow 10 minutes before checking.

1. Pull out oil level gauge and wipe it clean.
2. Insert oil level gauge and check that the engine oil level is within the range (A) as shown.
3. If it is out of range, adjust it.

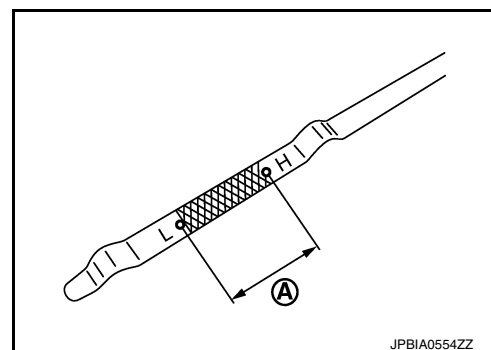

JPBIA0554ZZ

#### ENGINE OIL APPEARANCE

- Check engine oil for white milky appearance or excessive contamination.
- If engine oil becomes turbid and white, it is highly probable that it is contaminated with engine coolant. Repair or replace damaged parts.

#### ENGINE OIL LEAKS

Check for engine oil leaks around the following areas:

- Oil pan (upper and lower)
- Oil pan drain plug
- Oil pressure sensor
- Oil filter
- Oil cooler
- Oil level sensor
- Engine oil temperature sensor
- Intake valve timing control solenoid valve
- Exhaust valve timing control solenoid valve
- Mating surface between front cover and rocker cover
- Mating surface between cylinder block and cylinder head
- Mating surface between cylinder head and rocker cover
- Crankshaft oil seals (front and rear)
- Front cover

#### ENGINE OIL PRESSURE CHECK

##### WARNING:

- Be careful not to burn yourself, as engine oil may be hot.
- When checking engine oil pressure, shift selector should be in the "P" (Park) or "N" (Neutral) position, and apply parking brake securely.

1. Check engine oil level.

# ENGINE OIL

[HR16DE]

## < PERIODIC MAINTENANCE >

2. Disconnect harness connector at oil pressure switch. Remove oil pressure switch using suitable tool and install suitable tools (A/B).

**CAUTION:**

**Do not drop or shock oil pressure switch.**

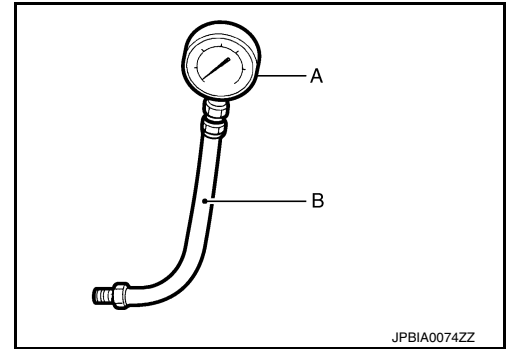

3. Start engine and warm it up to normal operating temperature.
4. Check engine oil pressure with engine running under no-load.

**NOTE:**

- When engine oil temperature is low, engine oil pressure becomes high.
- If difference is extreme, check oil passage and oil pump for engine oil leaks.

**Engine oil pressure** : Refer to [LU-15, "Engine Oil Pressure"](#).

5. After the inspections, install oil pressure switch as follows:

- a. Remove old liquid gasket adhering to oil pressure switch and engine.
- b. Apply liquid gasket and tighten oil pressure switch to specification.

**Use Genuine Liquid Gasket or equivalent. Refer to [GI-22, "Recommended Chemical Products and Sealants"](#).**

**Tightening torque** : Refer to [EM-34, "Exploded View"](#).

6. Check engine oil level.
7. After warming up engine, check that there is no engine oil leaks with the running engine.

## Draining

INFOID:000000009444775

**WARNING:**

- **Be careful not to get burned, as engine oil may be hot.**
- **Prolonged and repeated contact with used engine oil may cause skin cancer. Try to avoid direct skin contact with used engine oil. If skin contact is made, wash thoroughly with soap or hand cleaner as soon as possible.**

1. Warm up the engine, park the vehicle on a level surface and check for engine oil leaks. Refer to [LU-7, "Inspection"](#).
2. Stop the engine and wait for 10 minutes.
3. Loosen oil filler cap.
4. Remove drain plug and then drain engine oil.

## Refilling

INFOID:000000009444776

1. Install drain plug with new copper sealing washer. Refer to [EM-34, "Exploded View"](#).

**CAUTION:**

- **Be sure to clean drain plug.**
- **Do not reuse copper sealing washer.**

2. Refill with new engine oil.

**Engine oil capacity and viscosity** : Refer to [MA-11, "Fluids and Lubricants"](#).

**CAUTION:**

- **The refill capacity depends on the engine oil temperature and drain time. Use these specifications for reference only.**
- **Always use oil level gauge to determine the proper amount of engine oil in the engine.**



# ENGINE OIL

< PERIODIC MAINTENANCE >

[HR16DE]

3. Warm up engine and check area around drain plug and oil filter for engine oil leaks. Repair as necessary.
4. Stop engine and wait for 10 minutes.
5. Check the engine oil level. Refer to [LU-7. "Inspection"](#).

A

LU

C

D

E

F

G

H

I

J

K

L

M

N

O

P

## OIL FILTER

### Removal and Installation

INFOID:00000009444777

#### REMOVAL

1. Drain engine oil. Refer to [LU-8, "Draining"](#).
2. Remove oil filter using suitable tool (A).

⇐: Front

**WARNING:**

**Be careful not to get burned; engine and engine oil may be hot.**

**CAUTION:**

- When removing, prepare a shop cloth to absorb engine oil leaks and spills.
- Do not spill engine oil on drive belt.
- Completely wipe off any engine oil that spills on engine and vehicle.
- Oil filter is provided with relief valve. Use Genuine NIS-SAN oil filter or equivalent.

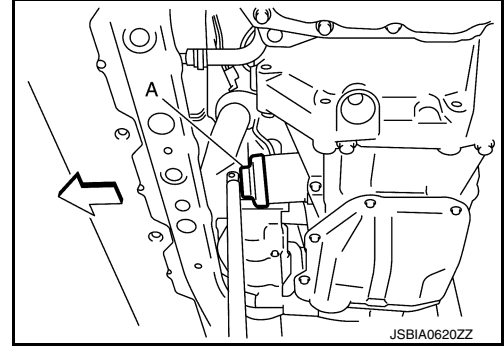

#### INSTALLATION

1. Remove foreign materials adhering to the oil filter installation surface.
2. Apply new engine oil to the oil seal contact surface of new oil filter.

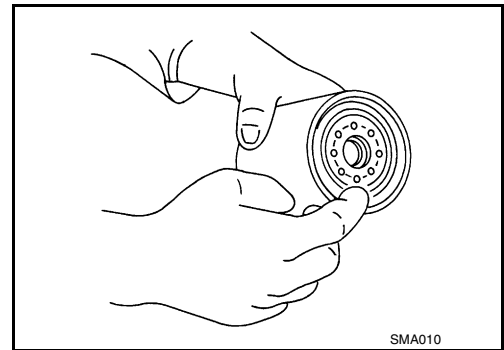

3. Screw oil filter manually until it touches the installation surface, then tighten it by 2/3 turn (A), or tighten to specification.

**Oil filter : 17.7 N·m (1.8 kg-m, 13 ft-lb)**

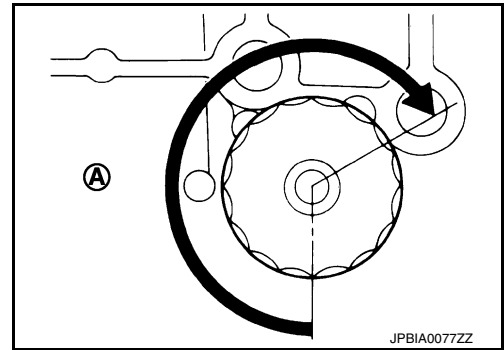

4. Refill engine with new engine oil. Refer to [LU-8, "Refilling"](#).

# OIL PUMP

< REMOVAL AND INSTALLATION >

[HR16DE]

## REMOVAL AND INSTALLATION

### OIL PUMP

#### Exploded View

INFOID:000000009444779

LU

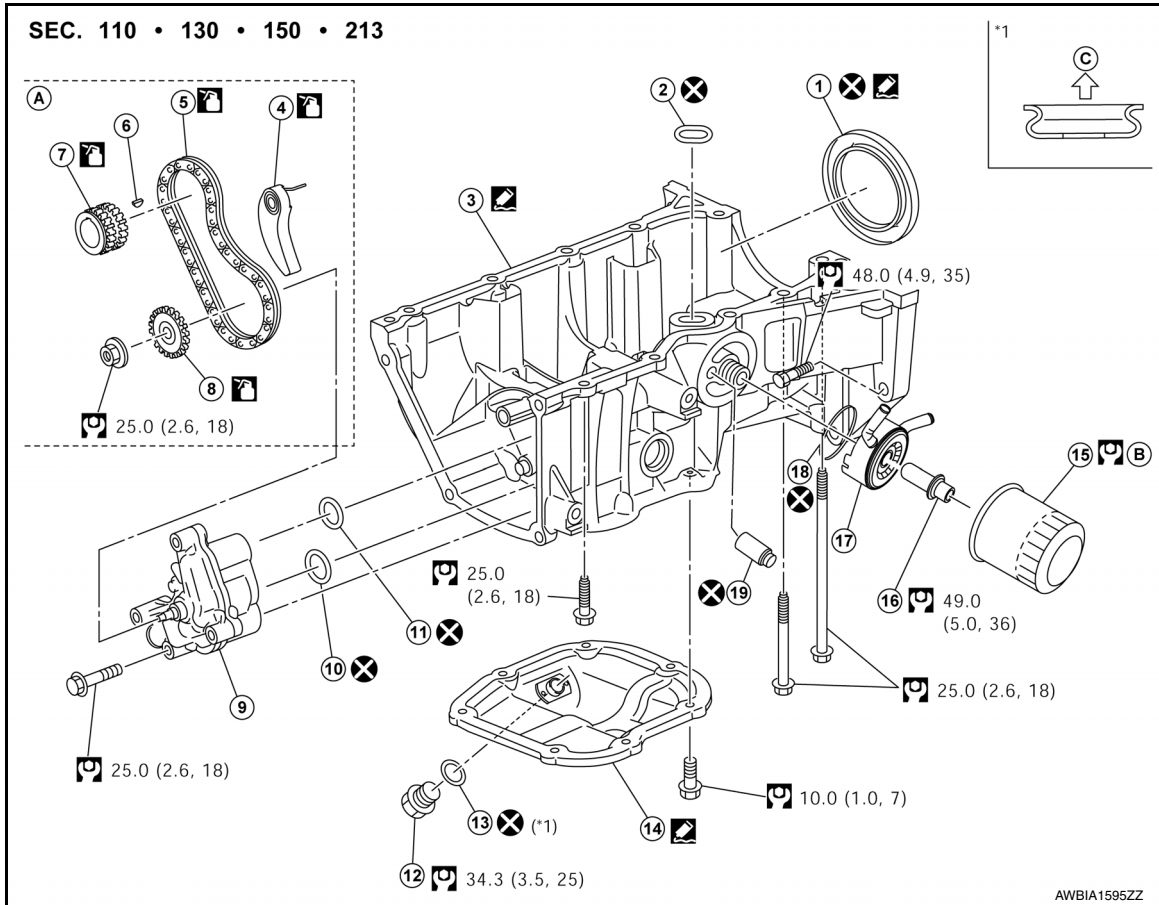

- |  |                                   |                                   |
|--|-----------------------------------|-----------------------------------|
| 1. Rear oil seal                                       | 2. O-ring                         | 3. Oil pan (upper)                |
| 4. Oil pump chain tensioner (for oil pump drive chain) | 5. Oil pump drive chain           | 6. Crankshaft key                 |
| 7. Crankshaft sprocket                                 | 8. Oil pump sprocket              | 9. Oil pump                       |
| 10. O-ring   | 11. O-ring                        | 12. Oil pan drain plug            |
| 13. Drain plug washer                                  | 14. Oil pan (lower)               | 15. Oil filter                    |
| 16. Connector bolt                                     | 17. Oil cooler                    | 18. O-ring                        |
| 19. Relief valve                                       | A. Refer to <a href="#">EM-51</a> | B. Refer to <a href="#">LU-10</a> |
| C. Oil pan (lower) side                                |                                   |                                   |

### Removal and Installation

INFOID:000000009444780

#### REMOVAL

1. Drain engine oil. Refer to [LU-8, "Draining"](#).
2. Remove timing chain and oil pump drive chain. Refer to [EM-51, "Removal and Installation"](#).

# OIL PUMP

[HR16DE]

## < REMOVAL AND INSTALLATION >

- Loosen the oil pump bolts in the reverse order as shown.
- Remove oil pump and O-rings.

**CAUTION:**

- Do not reuse O-rings.
- Do not disassemble oil pump.

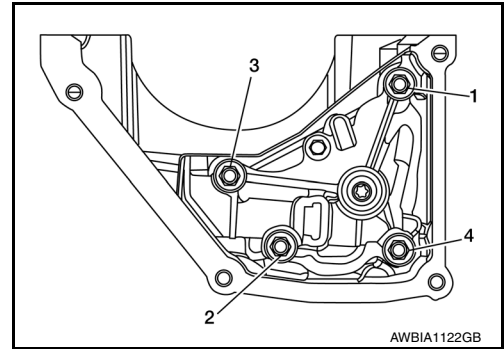

## INSTALLATION

- Install new O-rings on the oil pan (upper) before installing the oil pump. Refer to [LU-11, "Exploded View"](#).

**CAUTION:**

**Do not reuse O-rings.**

- Install the oil pump.
- Tighten the oil pump bolts to specification in the order shown.
- Install timing chain and oil pump drive chain. Refer to [EM-51, "Removal and Installation"](#).
- Refill engine with new engine oil. Refer to [LU-8, "Refilling"](#).

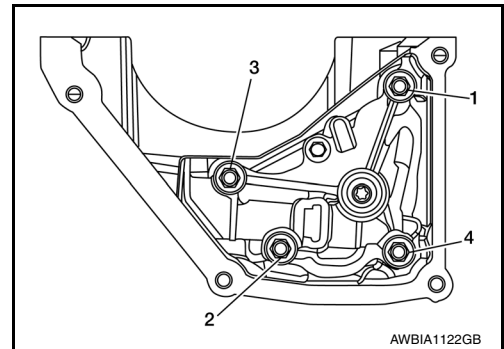

## INSPECTION AFTER INSTALLATION

- Before starting engine, check oil/fluid levels, including engine coolant and engine oil. If less than required quantity, fill to the specified level. Refer to [MA-11, "Fluids and Lubricants"](#).
- Use procedure below to check for fuel leaks.
- Turn ignition switch ON (with engine stopped). With fuel pressure applied to fuel piping, check for fuel leaks at connection points.
- Start engine. With engine speed increased, check again for fuel leaks at connection points.
- Run engine to check for unusual noise and vibration.

**NOTE:**

If hydraulic pressure inside timing chain tensioner drops after removal and installation, slack in the guide may generate a pounding noise during and just after engine start. However, this is normal. Noise will stop after hydraulic pressure rises.

- Warm up engine thoroughly to make sure there is no leaks of fuel, exhaust gas, or any oils/fluids including engine oil and engine coolant.
- Bleed air from passages in lines and hoses, such as in cooling system.
- After cooling down engine, again check oil/fluid levels, including engine oil and engine coolant. Refill to specified level, if necessary.
- Summary of the inspection items:

Item		Before starting engine	Engine running	After engine stopped
Engine coolant		Level	Leaks	Level
Engine oil		Level	Leaks	Level
Transmission/ transaxle fluid	CVT Models	Leaks	Level/Leaks	Leaks
	M/T Models	Level/Leaks	Leaks	Level/Leaks
Other oils and fluids*		Level	Leaks	Level
Fuel		Leaks	Leaks	Leaks
Exhaust gas		—	Leaks	—

\*Power steering fluid, brake fluid, etc.

# OIL COOLER

< REMOVAL AND INSTALLATION >

[HR16DE]

## OIL COOLER

### Exploded View

INFOID:000000009444781

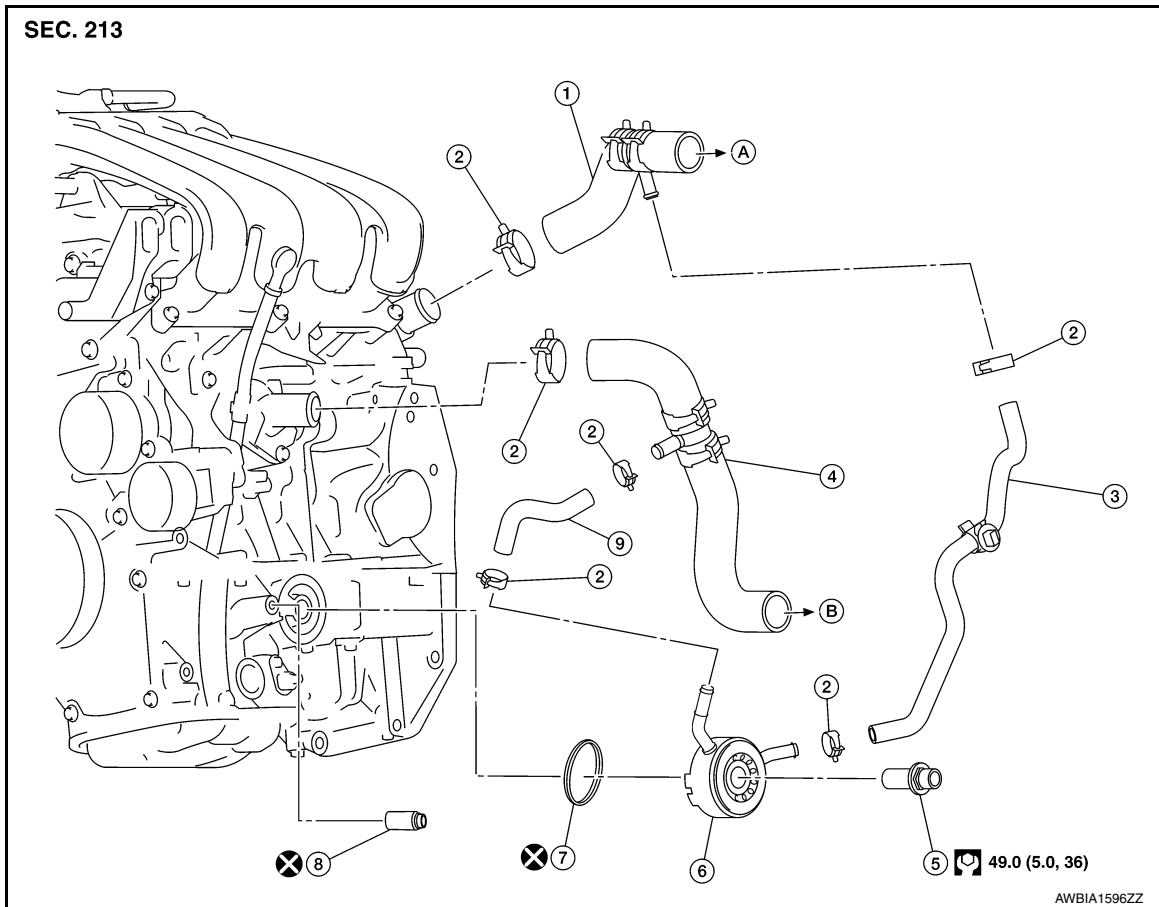

- |                             |                             |               |
|-----------------------------|-----------------------------|---------------|
| 1. Radiator hose (upper)    | 2. Hose clamp               | 3. Water hose |
| 4. Radiator hose (lower)    | 5. Connector bolt           | 6. Oil cooler |
| 7. O-ring                   | 8. Relief valve             | 9. Water hose |
| A. To radiator (upper side) | B. To radiator (lower side) |               |

## Removal and Installation

INFOID:000000009444782

### REMOVAL

#### **WARNING:**

**Do not remove the radiator cap when the engine is hot. Serious burns could occur from high-pressure engine coolant escaping from the radiator. Wrap a thick cloth around the radiator cap. Slowly turn it a quarter of a turn to release built-up pressure. Carefully remove radiator cap by turning it all the way.**

#### **NOTE:**

When removing components such as hoses, tubes/lines, etc., cap or plug openings to prevent fluid from spilling.

1. Drain engine oil. Refer to [LU-8, "Draining"](#).
2. Drain engine coolant. Refer to [CO-8, "Draining Engine Coolant"](#).
3. Remove oil filter. Refer to [LU-10, "Removal and Installation"](#).
4. Remove water hoses from the oil cooler.
5. Remove oil cooler and O-ring.

#### **CAUTION:**

**Do not reuse O-rings.**

# OIL COOLER

[HR16DE]

## < REMOVAL AND INSTALLATION >

### INSPECTION AFTER REMOVAL

#### Oil Cooler

Check oil cooler for cracks. Check oil cooler for clogging by blowing compressed air through engine coolant inlet. If necessary, replace oil cooler.

#### Relief Valve

Inspect relief valve for movement, cracks and breaks by pushing the ball. If replacement is necessary, remove the valve by prying it out using a suitable tool. Install a new valve by tapping it in place.

### INSTALLATION

Installation is in the reverse order of removal.

- Ensure that no foreign objects are adhering to the sealing surfaces of the oil cooler and oil pan (upper).
- Tighten connector bolt after aligning cutout (1) on oil cooler with protrusion (2) on oil pan (upper) side.

#### CAUTION:

- Do not reuse O-ring.
- Replace relief valve if removed.

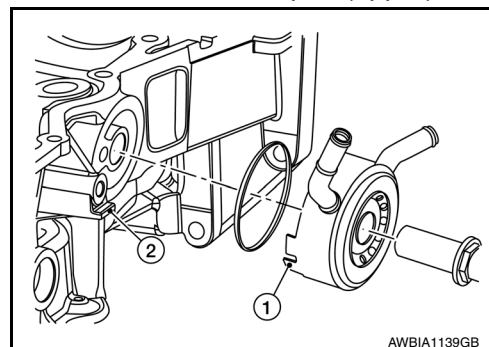

### INSPECTION AFTER INSTALLATION

- Before starting engine, check oil/fluid levels, including engine coolant and engine oil. If less than required quantity, fill to the specified level. Refer to [MA-11, "Fluids and Lubricants"](#).
- Use procedure below to check for fuel leaks.
- Turn ignition switch ON (with engine stopped). With fuel pressure applied to fuel piping, check for fuel leaks at connection points.
- Start engine. With engine speed increased, check again for fuel leaks at connection points.
- Run engine to check for unusual noise and vibration.

#### NOTE:

- If hydraulic pressure inside timing chain tensioner drops after removal and installation, slack in the guide may generate a pounding noise during and just after engine start. However, this is normal. Noise will stop after hydraulic pressure rises.
- Warm up engine thoroughly to make sure there is no leaks of fuel, exhaust gas, or any oils/fluids including engine oil and engine coolant.
- Bleed air from passages in lines and hoses, such as in cooling system.
- After cooling down engine, again check oil/fluid levels, including engine oil and engine coolant. Refill to specified level, if necessary.
- Summary of the inspection items:

Item		Before starting engine	Engine running	After engine stopped
Engine coolant		Level	Leaks	Level
Engine oil		Level	Leaks	Level
Transmission/ transaxle fluid	CVT Models	Leaks	Level/Leaks	Leaks
	M/T Models	Level/Leaks	Leaks	Level/Leaks
Other oils and fluids*		Level	Leaks	Level
Fuel		Leaks	Leaks	Leaks
Exhaust gas		—	Leaks	—

\*Power steering fluid, brake fluid, etc.

# SERVICE DATA AND SPECIFICATIONS (SDS)

< SERVICE DATA AND SPECIFICATIONS (SDS)

[HR16DE]

## SERVICE DATA AND SPECIFICATIONS (SDS)

### SERVICE DATA AND SPECIFICATIONS (SDS)

#### Periodical Maintenance Specification

INFOID:000000009444783

#### ENGINE OIL CAPACITY (APPROXIMATE)

Unit: ℓ (US qt, Imp qt)

Drain and refill	With oil filter change	3.5 (3 3/4, 3 1/8)
	Without oil filter change	3.2 (3 3/8, 2 7/8)
Dry engine (Overhaul)		3.5 (3 3/4, 3 1/8)

#### Engine Oil Pressure

INFOID:000000009444784

Unit: kPa (kg/cm<sup>2</sup>, psi)

Engine Speed	Approximate discharge pressure*	
	M/T	CVT
600 rpm	More than 98 (1.0, 14.2)	
2,000 rpm	More than 294 (3.0, 42.6)	
6,000 rpm	More than 392 (4.0, 56.8)	

\*: Engine oil temperature at 80°C (176°F).